

**EMC MEASUREMENT/TECHNICAL REPORT
FOR PART 15.247 APPLICATION**

MANUFACTURER : Intermec Corp.
PRODUCT: MODEL 2100 with 900 MHz RFID Module
Configuration: 2100C61XXXB91

FCC ID: HN2UAPRFID-900

October 15, 1999

This report concerns : (check one) Original grant <input checked="" type="checkbox"/> Class II change _____	
*Class B verification <input checked="" type="checkbox"/> Class A verification _____ **Class I change _____	
Equipment type: 900MHz Spread Spectrum Transceiver	
Limits used: (check one)	
CISPR 22 <input checked="" type="checkbox"/> for digital emissions portion	Part 15 <input checked="" type="checkbox"/> for RF portion
Measurement procedure used is ANSI C63.4-1992 unless another is specified.	
Other test procedure: _____	
This report is based on the measurements on Model <u>2100</u> .	
EUT Serial number: <u>915T0018</u> .	
Report reviewed and approved by	
Kursat Eroglu, EMC Engineer _____ 6001 36 th Ave. W Everett WA 98203 Phone: 206 356 1765 Fax: 206 348 2633 E-Mail keroglu@intermec.com	

*Do not bind or staple this report. A horizontal rubber band plus paper clip at top of document is preferred.
Not to be filed with Equipment Authorization Branch of FCC unless requested.

Table of Contents

1	GENERAL INFORMATION	3
1.1	Summary of Test Results	3
1.2	Product Description	3
1.3	Antenna System	3
1.4	Class A Justification	3
1.5	Related Submittal(s)/Grant(s)	3
2	TEST CONDITIONS	4
2.1	Tested System Details	4
2.2	Block Diagram of Tested System	4
2.3	Test Methodology	4
2.4	Test Facility	4
2.5	Test Summary	5
2.6	Environmental Conditions	5
3	PRODUCT LABELING	5
3.1	Location of Label on EUT	5
4	TEST EQUIPMENT	6
4.1	Test Equipment	6
4.2	Accessories	6
5	TEST DATA AND RESULTS	7
5.1	Band Usage and Dwell Time	7
5.2	Peak Power Measurement	7
5.3	Channel Bandwidth Measurement	12
5.4	Conducted Out-of-Band Emissions	12
5.5	Radiated Emissions	18
5.6	Conducted Powerline Emissions	19

1 GENERAL INFORMATION

1.1 Summary of Test Results

Model 2100 with 900 MHz RFID module was tested to the requirements of Part 15.247 of the FCC Rules for 900 MHz band spread spectrum transceivers to verify its compliance. The product passed all tests with comfortable margins beyond test instrument tolerances.

1.2 Product Description

Model 2100 with 900 MHz RFID module is an RFID configuration of our Model 2100 Universal Access Point, which contains a 900 MHz RFID reader module. The module uses 900 MHz spread spectrum signals to interrogate, and program RFID tags. The module has a sheet metal enclosure inside the v-cast metal enclosure of Model 2100. It uses two 6 dB patch antennas alternatively. Detailed pictures of the product and the circuit boards are in the attached exhibits. Power levels, frequency ranges and channel characteristics are **not** user adjustable.

1.3 Antenna System

Model 2100 with 900 MHz RFID module uses two 6 dB patch antennas alternatively for spacial and polarization diversity. The antennas are connected through a TNC connector to the transmitter. Compliance with part 15.203 is achieved by an integrated RFID tag on the antenna, which identifies the antenna and is hardwired to the transmission cable. When the product is turned on it transmits an interrogation signal to the antenna. If it cannot identify the antenna through the transmission cable, it will not operate. Since the identification is made through the transmission cable only, no other antennas can be used with the product.

1.4 Class A Justification

Intermec serves industrial customers such as warehouses, factories, storage facilities etc. Since this ruggedized product is used in these environments it falls under Part 15 Class A for digital emissions.

1.5 Related Submittal(s)/Grant(s)

A similar version of this transceiver using 2.4 GHz was certified by the FCC to IBM in 1997 under the FCC identifier ANORFID-2000. The same 2.4 GHz module is now in process of being certified in our Model 2100 under FCC ID: HN2UAPRFID-24.

2 Test Conditions

2.1 Tested System Details

The product was put into transmit modes (continuous for antenna port measurements, hopping for radiated emissions). Worst case conditions were found and used for the radiated emissions.

2.2 Block Diagram of Tested System

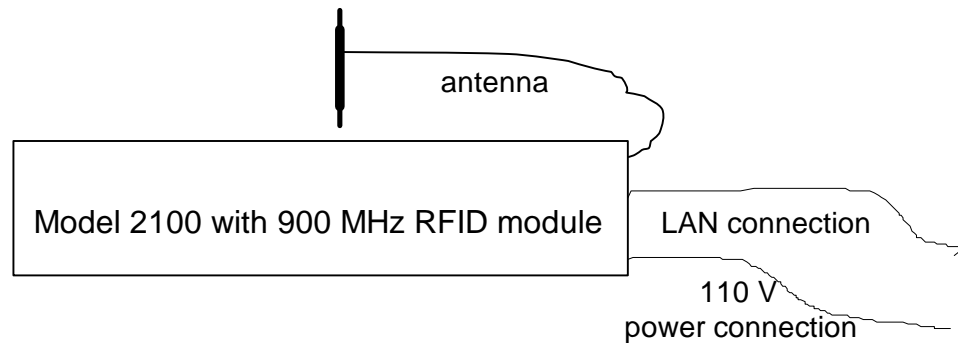

2.3 Test Methodology

Digital emissions tests were performed according to the procedures in ANSI C63.4-1992. For radio performance tests procedures given in Part 15 (paragraphs 109, 247, 205, 209) and described in "Test Procedure Hints", published by Authorization and Evaluation Division.

2.4 Test Facility

The open area test site and conducted measurement facility used to collect the radiated data is in Intermec Corp. facilities at 6001 36th Ave. W Everett, WA 98203. This site has been fully described in a report dated 25 Feb. 94 submitted to your office, and accepted in a letter dated May 24, 1994 (31040/SIT). Latest continued compliance report for the OATS site was submitted to FCC in June 1999.

2.5 Test Summary

Specification Paragraph	Description	Test Data Section	Status
15.207	Powerline Conducted RFI	5.6	passed
15.109	Radiated Emissions	5.5.1	passed
15.247(a)(1)	Channel Utilization	5.1	passed
15.247(a)(1)	Channel Bandwidth	5.3	passed
15.247(b)	Maximum Peak Output Power	5.2	passed
15.247(c)	Conducted Out of Band Emissions	5.4	passed
15.205	Restricted Band Emissions	5.4, 5.5	passed
15.209	Radiated Spurious Emissions	5.5.2	passed

2.6 Environmental Conditions

All tests were performed at Intermec test facilities under following conditions:

Temperature: ambient (10 °C to 25 °C)

Humidity: 50% to 80%

Altitude: 550 ft

3 PRODUCT LABELING

3.1 Location of Label on EUT

The below shown label will be affixed to the bottom of the product.

<p>Model 2100 (RFID) Configuration: 2100C61XXXB91</p> <p>FCC ID: HN2UAPRFID-900 Canada: 1223 XXX XXX RSS/CNR 210 ICES-003</p> <p>This device complies with Part 15 of the FCC Rules and with RSS-210 of Industry Canada. Operation is subject to the following two conditions: (1) This device may not cause harmful interference, and (2) This device must accept any interference received, including interference that can cause undesired operation. See Manual. Referéz vous à la documentation.</p>
--

4 TEST EQUIPMENT

4.1 Test Equipment

Type	Manufacturer/ Model No.	Serial No.	Last Cal.	Cal. Interval
Spectrum Analyzer/ EMI Receiver	Rohde & Schwartz ESMI 100Hz - 26.5 GHz	DE11220	12/29/98	1 year
Biconical Antenna	EMCO 3110B	1412	6/15/99	1 year
Log-periodic Antenna	EMCO 3146	1512	6/15/99	1 year
Horn Antenna	EMCO 3115	3720	6/17/99	2 years
LISN	EMCO	1166	11/30/98	1 year
Spectrum Analyzer	8591A	2932A00296	12/4/98	1 year
Preamplifier	HP8447F	2944A03597	1/25/99	1 year
Bilog Antenna	CBL611B	2075	4/23/99	1 year

4.2 Accessories

All accessories used at Intermec OATS and EMC Lab such as cables, attenuators, filters etc. are measured in predetermined intervals and their loss factors are recorded for adjustment of measured values.

5 TEST DATA AND RESULTS

5.1 Band Usage and Dwell Time

5.1.1 Procedure

The EUT was put into a random transmit mode utilizing all available channels. The analyzer was set to a span from 900 MHz to 930 MHz in max hold mode recording all transmissions. Then the band edges were investigated for any spurious emissions. Finally, the analyzer was set to 0 span with video triggering around low, medium and high channels to determine dwell time. The sweep time was set to 10 s.

5.1.2 Results

The plots on the following pages show that the EUT uses 902.6 MHz to 927.4 MHz band complying with 15.247 requirements. Also, no anomalous band edge emissions were detected.

For dwell time the time between hops was determined to be 9.440 seconds. This makes the average number of hops in a 30 second interval to be 3.178. Since the time spent at each frequency is 120 ms, the average time spent on any channel within 30 seconds will be 0.381 seconds complying with the limit of 0.400 seconds dwell time.

5.2 Peak Power Measurement

5.2.1 Procedure

The EUT was put into a continuous transmit mode. The analyzer was set to a 20 MHz span around the selected channel with 1 MHz resolution bandwidth and 1 MHz video bandwidth. A 6 db attenuator was used and compensated for in the measurement. Cable losses were automatically compensated by the analyzer. The analyzer was put into max hold mode and the peak value measured. Peak power of low, medium and high channels was measured.

5.2.2 Results

The highest measured peak value was 24.72 dBm at 902.6 MHz complying with the 30 dBm requirement of part 15.247.

For file size considerations, this report has been split into 4 pieces. Please see the next file for the rest of the report.