



Prüfbericht-Nr.: <i>Test report no.:</i>	CN246337 001	Auftrags-Nr.: <i>Order no.:</i>	48226341	Seite 1 von 32 Page 1 of 32
Kunden-Referenz-Nr.: <i>Client reference no.:</i>	N/A	Auftragsdatum: <i>Order date:</i>	2023-11-21	
Auftraggeber: <i>Client:</i>	Acer Incorporated 8F, 88, Sec. 1, Xintai 5th Rd. Xizhi, New Taipei City 221 Taiwan			
Prüfgegenstand: <i>Test item:</i>	PREDATOR Connect W6x Wi-Fi 6 Router			
Bezeichnung / Typ-Nr.: <i>Identification / Type no.:</i>	W6x			
Auftrags-Inhalt: <i>Order content:</i>	FCC Part 15C Test report (WiFi 2.4GHz)			
Prüfgrundlage: <i>Test specification:</i>	FCC 47CFR Part 15: Subpart C Section 15.247			
Wareneingangsdatum: <i>Date of sample receipt:</i>	2024-03-18			
Prüfmuster-Nr.: <i>Test sample no.:</i>	A003677464-003			
Prüfzeitraum: <i>Testing period:</i>	2024-03-27 - 2024-04-29			
Ort der Prüfung: <i>Place of testing:</i>	EMC/RF Taipei Testing Site			
Prüflaboratorium: <i>Testing laboratory:</i>	Taipei Testing Laboratories			
Prüfergebnis*: <i>Test result*:</i>	Pass			
überprüft von: <i>compiled by:</i>	 Allen Yu	genehmigt von: <i>authorized by:</i>	 Brenda Chen	
Datum: <i>Date:</i>	2024-05-20	Ausstellungsdatum: <i>Issue date:</i>	2024-05-20	
Stellung / Position:	Section Manager	Stellung / Position:	Senior Project Manager	
Sonstiges / Other:				
Zustand des Prüfgegenstandes bei Anlieferung: <i>Condition of the test item at delivery:</i>		Prüfmuster vollständig und unbeschädigt <i>Test item complete and undamaged</i>		
* Legende:	1 = sehr gut P(ass) = entspricht o.g. Prüfgrundlage(n)	2 = gut F(ail) = entspricht nicht o.g. Prüfgrundlage(n)	3 = befriedigend N/A = nicht anwendbar	4 = ausreichend N/T = nicht getestet
* Legend:	1 = very good P(ass) = passed a.m. test specification(s)	2 = good F(ail) = failed a.m. test specification(s)	3 = satisfactory N/A = not applicable	4 = sufficient N/T = not tested
Dieser Prüfbericht bezieht sich nur auf das o.g. Prüfmuster und darf ohne Genehmigung der Prüfstelle nicht auszugsweise vervielfältigt werden. Dieser Bericht berechtigt nicht zur Verwendung eines Prüfzeichens. <i>This test report only relates to the a. m. test sample. Without permission of the test center this test report is not permitted to be duplicated in extracts. This test report does not entitle to carry any test mark.</i>				

Prüfbericht-Nr.: CN246337 001
Test report no.:

Seite 2 von 32
Page 2 of 32

Anmerkungen
Remarks

1	<p>Alle eingesetzten Prüfmittel waren zum angegebenen Prüfzeitraum gemäß eines festgelegten Kalibrierungsprogramms unseres Prüfhauses kalibriert. Sie entsprechen den in den Prüfprogrammen hinterlegten Anforderungen. Die Rückverfolgbarkeit der eingesetzten Prüfmittel ist durch die Einhaltung der Regelungen unseres Managementsystems gegeben. Detaillierte Informationen bezüglich Prüfkonditionen, Prüfequipment und Messunsicherheiten sind im Prüflabor vorhanden und können auf Wunsch bereitgestellt werden.</p> <p><i>The equipment used during the specified testing period was calibrated according to our test laboratory calibration program. The equipment fulfils the requirements included in the relevant standards. The traceability of the test equipment used is ensured by compliance with the regulations of our management system. Detailed information regarding test conditions, equipment and measurement uncertainty is available in the test laboratory and could be provided on request.</i></p>
2	<p>Wie vertraglich vereinbart, wurde dieses Dokument nur digital unterzeichnet. Der TÜV Rheinland hat nicht überprüft, welche rechtlichen oder sonstigen diesbezüglichen Anforderungen für dieses Dokument gelten. Diese Überprüfung liegt in der Verantwortung des Benutzers dieses Dokuments. Auf Verlangen des Kunden kann der TÜV Rheinland die Gültigkeit der digitalen Signatur durch ein gesondertes Dokument bestätigen. Diese Anfrage ist an unseren Vertrieb zu richten. Eine Umweltgebühr für einen solchen zusätzlichen Service wird erhoben. Informationen zur Verifizierung der Authentizität unserer Dokumente erhalten Sie auf folgender Webseite: go.tuv.com/digital-signature</p> <p><i>As contractually agreed, this document has been signed digitally only. TUV Rheinland has not verified and unable to verify which legal or other pertaining requirements are applicable for this document. Such verification is within the responsibility of the user of this document. Upon request by its client, TUV Rheinland can confirm the validity of the digital signature by a separate document. Such request shall be addressed to our Sales department. An environmental fee for such additional service will be charged. For information on verifying the authenticity of our documents, please visit the following website: go.tuv.com/digital-signature</i></p>
3	<p>Prüfklausel mit der Note * wurden an qualifizierte Unterauftragnehmer vergeben und sind unter der jeweiligen Prüfklausel des Berichts beschrieben. Abweichungen von Prüfspezifikation(en) oder Kundenanforderungen sind in der jeweiligen Prüfklausel im Bericht aufgeführt.</p> <p><i>Test clauses with remark of * are subcontracted to qualified subcontractors and described under the respective test clause in the report. Deviations of testing specification(s) or customer requirements are listed in specific test clause in the report.</i></p>
4	<p>Die Entscheidungsregel für Konformitätserklärungen basierend auf numerischen Messergebnissen in diesem Prüfbericht basiert auf der "Null-Grenzwert-Regel" und der "Einfachen Akzeptanz" gemäß ILAC G8:2019 und IEC Guide 115:2021, es sei denn, in der auf Seite 1 dieses Berichts genannten angewandten Norm ist etwas anderes festgelegt oder vom Kunden gewünscht. Dies bedeutet, dass die Messunsicherheit nicht berücksichtigt wird und daher auch nicht im Prüfbericht angegeben wird. Zu weiteren Informationen bezüglich des Risikos durch diese Entscheidungsregel siehe ILAC G8:2019.</p> <p><i>The decision rule for statements of conformity, based on numerical measurement results, in this test report is based on the "Zero Guard Band Rule" and "Simple Acceptance" in accordance with ILAC G8:2019 and IEC Guide 115:2021, unless otherwise specified in the applied standard mentioned on Page 1 of this report or requested by the customer. This means that measurement uncertainty is not taken in account and hence also not declared in the test report. For additional information to the resulting risk based of this decision rule please refer to ILAC G8:2019.</i></p>

TEST SUMMARY

Report Section	FCC Clause	Test Item	Result
5.1.1	15.247(b) & 15.203	Antenna Requirement	Pass
5.1.2	15.247(b)(3)	Peak Output Power	Pass
5.1.3	15.247(a)(2)	6 dB Bandwidth	Pass
5.1.3	2.1049	99% Occupied Bandwidth	Pass
5.1.4	15.247(e)	Power Spectral Density	Pass
5.1.5	15.247(d)	Conducted Spurious Emissions and Band Edges	Pass
5.1.6	15.247(d) & 15.205 & 15.209	Radiated Spurious Emissions and Band Edges	Pass
5.2.1	15.207	Mains Conducted Emission	Pass

Note: Determining compliance based on the results of the compliance measurement, not taking into account measurement instrumentation uncertainty.

Contents

HISTORY OF THIS TEST REPORT	6
1. GENERAL REMARKS	7
1.1 COMPLEMENTARY MATERIALS	7
1.2 DECISION RULE OF CONFORMITY	7
2. TEST SITES	8
2.1 TEST LABORATORY	8
2.2 TEST FACILITY	8
2.3 TRACEABILITY	9
2.4 CALIBRATION	9
2.5 MEASUREMENT UNCERTAINTY	9
3. GENERAL PRODUCT INFORMATION	10
3.1 PRODUCT FUNCTION AND INTENDED USE	10
3.2 SYSTEM DETAILS AND RATINGS	10
3.3 NOISE GENERATING AND NOISE SUPPRESSING PARTS	11
3.4 SUBMITTED DOCUMENTS	11
4. TEST SET-UP AND OPERATION MODES	12
4.1 PRINCIPLE OF CONFIGURATION SELECTION	12
4.2 CARRIER FREQUENCY AND CHANNEL	12
4.3 TEST OPERATION AND TEST SOFTWARE	13
4.4 SPECIAL ACCESSORIES AND AUXILIARY EQUIPMENT	15
4.5 TEST SETUP DIAGRAM	15
4.6 DUTY CYCLE OF TEST SIGNAL	17
5. TEST RESULTS	18
5.1 TRANSMITTER REQUIREMENT & TEST SUITES	18
5.1.1 <i>Antenna Requirement</i>	<i>18</i>
5.1.2 <i>Peak Output Power</i>	<i>19</i>
5.1.3 <i>6 dB Bandwidth and 99% Occupied Bandwidth</i>	<i>23</i>
5.1.4 <i>Power Spectral Density</i>	<i>24</i>
5.1.5 <i>Conducted Spurious Emissions and Frequency Band Edges Measured in 100 kHz Bandwidth</i>	<i>25</i>
5.1.6 <i>Radiated Spurious Emissions and Band Edges</i>	<i>26</i>
5.2 MAINS EMISSION	31
5.2.1 <i>Mains Conducted Emission</i>	<i>31</i>

Prüfbericht - Nr.: **CN246337 001**
Test Report No.

Seite 5 von 32
Page 5 of 32

APPENDIX A - TEST RESULT OF CONDUCTED

APPENDIX B - TEST RESULT OF RADIATED EMISSIONS & MAINS CONDUCTED EMISSION

APPENDIX SP - PHOTOGRAPHS OF TEST SETUP

APPENDIX EP - PHOTOGRAPHS OF EUT

Prüfbericht - Nr.: **CN246337 001**
Test Report No.

Seite 6 von 32
Page 6 of 32

HISTORY OF THIS TEST REPORT

Revision	Description	Date Issued
R01	Original Release	2024-05-20

1. General Remarks

1.1 Complementary Materials

All attachments are integral parts of this test report. This applies especially to the following appendix:

Appendix A - Test Result of Conducted

Appendix B - Test Result of Radiated Emissions & Mains Conducted Emission

Appendix SP - Photographs of Test Setup

Appendix EP - Photographs of EUT

Applied Standard and Test Levels

Radio
FCC 47CFR Part 15: Subpart C Section 15.247
FCC 47CFR Part 2: Subpart J Section 2.1049
ANSI C63.10:2013
KDB 558074 D01 15.247 Meas Guidance v05r02
KDB 662911 D01 Multiple Transmitter Output v02r01

1.2 Decision Rule of Conformity

The decision rule of conformity of this test report is following the requirements of the requested standard in the quotation, and agreed among testing laboratory and manufacturer (applicant) to exclude the consideration of Measurement Uncertainty, unless it is required by the specific standard.

2. Test Sites

2.1 Test Laboratory

Taipei Testing Laboratories

11F. No.758, Sec. 4, Bade Rd., Songshan Dist.
Taipei City 105
Taiwan (R.O.C.)

2.2 Test Facility

Taipei Testing Laboratories

No.458-18, Sec. 2, Fenliao Rd., Linkou Dist.,
New Taipei City 244
Taiwan (R.O.C.)
FCC Registration No.: 180491
ISED Registration No.: 25563

2.3 Traceability

All measurement equipment calibrations are traceable to NML(Taiwan)/NIST(USA) or where calibration is performed outside Taiwan, to equivalent nationally recognized standards organizations.

2.4 Calibration

Equipment requiring calibration is calibrated periodically in a suitably accredited Calibration Lab. Additionally all equipment is verified for proper performance on a regular basis using in house standards or comparisons.

2.5 Measurement Uncertainty

All measurement uncertainty values are shown with a coverage factor of $k=2$ to indicate a 95% level of confidence.

Emission Measurement Uncertainty

Parameter	Uncertainty
Radiated Emission (9 kHz ~ 30 MHz)	± 1.15 dB
Radiated Emission (30 MHz ~ 200 MHz)	± 1.30 dB
Radiated Emission (200 MHz ~ 1 GHz)	± 1.30 dB
Radiated Emission (1 GHz ~ 18 GHz)	± 1.54 dB
Radiated Emission (18 GHz ~ 40 GHz)	± 2.52 dB
Mains Conducted Emission	± 1.65 dB

3. General Product Information

3.1 Product Function and Intended Use

The EUT is a PREDATOR Connect W6x Wi-Fi 6 Router. It contains a WLAN compatible module enabling the user to communicate data through a Wireless interface.
 For details refer to the User Guide, Data Sheet and Circuit Diagram.

3.2 System Details and Ratings

Basic Information of EUT

Item	EUT information
Kind of Equipment/Test Item	PREDATOR Connect W6x Wi-Fi 6 Router
Type Identification	W6x
FCC ID	HLZW6X

Technical Specification of EUT

Item	EUT information	
Operating Frequency	2412 MHz ~ 2462 MHz	
Channel Number	802.11b/g/n/ax HT20/HE20: 11 802.11n/ax HT40/HE40: 7	
Data Rate	802.11b: 11.0 / 5.5 / 2.0 / 1.0 Mbps 802.11g: 54.0 / 48.0 / 36.0 / 24.0 / 18.0 / 12.0 / 9.0 / 6.0 Mbps 802.11n/ax: up to MCS11	
Operation Voltage	Adapter input 100-240 Vac, output 12 Vdc	
Extreme Temperature Range	0 ~ 40 °C	
Modulation	DSSS (DBPSK, DQPSK, CCK) OFDM (BPSK, QPSK, 16QAM, 64QAM) OFDMA (1024QAM)	
Maximum Output Power (mW)	CDD Mode	802.11b: 289.16
		802.11g: 942.43
		802.11n HT20: 829.79
		802.11n HT40: 237.11
		802.11ax HE20: 860.06
		802.11ax HE40: 244.6
	Beamforming Mode	802.11ax HE20: 215.05
		802.11ax HE40: 61.16
Antenna Information	Refer to 5.1.1	
Accessory Device	Refer to 4.4	

3.3 Noise Generating and Noise Suppressing Parts

Refer to the Circuit Diagram.

3.4 Submitted Documents

- Circuit Diagram
- Instruction Manual
- Rating Label
- Technical Description

4. Test Set-up and Operation Modes

4.1 Principle of Configuration Selection

The test modes were adapted accordingly in reference to the instructions for use.

During testing, Channel and Power Controlling Software provided by the customer was used to control the operating channel as well as the output power level. The RF output power selection is for the setting of RF output expected by the customer and is going to be fixed on the firmware of the final end product.

Table for Parameters of Test Software Setting

802.11b		802.11g		802.11n HT20 802.11ax HE20		802.11n HT40 802.11ax HE40	
Channel	Power Setting	Channel	Power Setting	Channel	Power Setting	Channel	Power Setting
1	16	1	16.5	1	17	3	11
6	17.5	2	18.5	2	18.5	4	11
11	17	3	21	3	20	5	16
		6	22.5	4	21.5	6	17.5
		10	21	6	23	8	16.5
		11	18.5	8	21.5	9	13
				9	20.5		
				10	20		
				11	17		

4.2 Carrier Frequency and Channel

802.11b, 802.11g, 802.11n HT20, 802.11ax HE20:

Channel	Frequency (MHz)	Channel	Frequency (MHz)
1	2412	8	2447
2	2417	9	2452
3	2422	10	2457
4	2427	11	2462
5	2432		
6	2437		
7	2442		

802.11n HT40, 802.11ax HE40:

Channel	Frequency (MHz)	Channel	Frequency (MHz)
3	2422	7	2442
4	2427	8	2447
5	2432	9	2452
6	2437		

4.3 Test Operation and Test Software

Setup for testing: Test samples are provided with LAN interface which makes it possible to control them through a test software installed on a notebook computer.

This software was running on the laptop computer connected to the EUT. It was used to enable the operation modes listed as below.

Test Software	QATool_UIv2.69_DLLv6.75_ap_2021.06.25(V07)c
---------------	---

The samples were used as follows:
 A003677464-003

Full test was applied on all test modes, but only worst case was shown.

The EUT incorporates a MIMO function. Physically, the EUT provides two completed transmitters and receivers.

Modulation Mode	Tx Function
802.11b	4TX (MIMO)
802.11g	4TX (MIMO)
802.11n HT20	4TX (MIMO)
802.11n HT40	4TX (MIMO)
802.11ax HE20	4TX (MIMO)
802.11ax HE40	4TX (MIMO)

* The modulation and bandwidth are similar for 802.11n mode HT20/HT40 and 802.11ax HE20/HE40, therefore, only investigated worse case as representative mode in test report.

** For Beamforming mode, only the output power is evaluated and presented in this report.

EUT Configure Mode	Applicable To				Description
	Antenna Port Conducted Measurement	Radiated Spurious Emissions above 1 GHz	Radiated Spurious Emissions below 1 GHz	Mains Conducted Emission	
-	√	√	√	√	-

Note:

- The EUT had been pre-tested on the positioned of each 3 axis. The worst case was found when position on **Z-plane**.
- "-" means no effect.

Antenna Port Conducted Measurement (Power only)

- Pre-Scan full test was applied on all test modes, but only worst case was shown.
- Following channel(s) was (were) selected for the final test as listed below.

EUT Configure Mode	Mode	Available Channel	Tested Channel	Date Rate (Mbps)
CDD	802.11b	1 to 11	1, 6, 11	1.0
	802.11g	1 to 11	1, 2, 3, 6, 10, 11	6.0
	802.11n HT20	1 to 11	1, 2, 3, 4, 6, 8, 9, 10, 11	MCS0
	802.11n HT40	3 to 9	3, 4, 5, 6, 8, 9	MCS0
	802.11ax HE20	1 to 11	1, 2, 3, 4, 6, 8, 9, 10, 11	NSS1 MCS0
	802.11ax HE40	3 to 9	3, 4, 5, 6, 8, 9	NSS1 MCS0
Beamforming	802.11ax HE20	1 to 11	1, 2, 3, 4, 6, 8, 9, 10, 11	NSS1 MCS0
	802.11ax HE40	3 to 9	3, 4, 5, 6, 8, 9	NSS1 MCS0

Prüfbericht - Nr.: CN246337 001
Test Report No.

 Seite 14 von 32
 Page 14 of 32

Antenna Port Conducted Measurement (All other conducted)

- Pre-Scan full test was applied on all test modes, but only worst case was shown.
- Following channel(s) was (were) selected for the final test as listed below.

EUT Configure Mode	Mode	Available Channel	Tested Channel	Date Rate (Mbps)
-	802.11b	1 to 11	1, 6, 11	1.0
-	802.11g	1 to 11	1, 6, 11	6.0
-	802.11ax HE20	1 to 11	1, 6, 11	NSS1 MCS0
-	802.11ax HE40	3 to 9	3, 6, 9	NSS1 MCS0

Radiated Spurious Emissions (Above 1 GHz)

- Pre-Scan full test was applied on all test modes, but only worst case was shown.
- Following channel(s) was (were) selected for the final test as listed below.

EUT Configure Mode	Mode	Available Channel	Tested Channel	Date Rate (Mbps)
-	802.11b	1 to 11	1, 6, 11	1.0
-	802.11g	1 to 11	1, 6, 11	6.0
-	802.11ax HE20	1 to 11	1, 6, 11	NSS1 MCS0
-	802.11ax HE40	3 to 9	3, 6, 9	NSS1 MCS0

Radiated Spurious Emissions (Below 1 GHz)

- Pre-Scan full test was applied on all test modes, but only worst case was shown.
- Following channel(s) was (were) selected for the final test as listed below.

EUT Configure Mode	Mode	Available Channel	Tested Channel	Date Rate (Mbps)
-	802.11g	1 to 11	6	6.0

Mains Conducted Emission

- Pre-Scan full test was applied on all test modes, but only worst case was shown.
- Following channel(s) was (were) selected for the final test as listed below.

EUT Configure Mode	Mode	Available Channel	Tested Channel	Date Rate (Mbps)
-	802.11g	1 to 11	6	6.0

Test Condition

Test Item	Ambient Temperature	Relative Humidity	Tested by
Conducted Measurement	22.3-23.9 °C	55-62 %	Andy Chen
Radiated Spurious Emissions above 1 GHz	24.5-26.7 °C	52-57 %	Chuan Chu
Radiated Spurious Emissions below 1 GHz	24.5-26.7 °C	52-57 %	Chuan Chu
Mains Conducted Emission	20.1-25.9 °C	50.2-58.9 %	Roger Liao

4.4 Special Accessories and Auxiliary Equipment

The product has been tested together with the following additional accessories:

Accessory of EUT

No.	Product	Brand	Model	Description
-	Adapter	FUSHIGANG	AS3603A-1202500DM	I/P: 100-240 Vac, 50/60 Hz, 1000mA O/P: 12 Vdc, 2500mA
A	Adapter	FUSHIGANG	AS3603A-1202500US	I/P: 100-240 Vac, 50/60 Hz, 1000mA O/P: 12 Vdc, 2500mA
B	LAN Cable	chntaike	K124-050	160cm

Support Unit

Support Unit								
No	Description	Brand	Model	S/N	Shielded	Ferrite Core (Qty)	Length (cm)	Remark
1	NB	HP	15s-da1046TX	CND9111RJB	-	-	-	-
2	USB Flash Drive	SanDisk	BM2204581574	N/A	-	-	-	-
3	AC Adapter	HP	TPN-LA15	N/A	NO	NO	285	-

4.5 Test Setup Diagram

<Radiated Spurious Emissions mode>

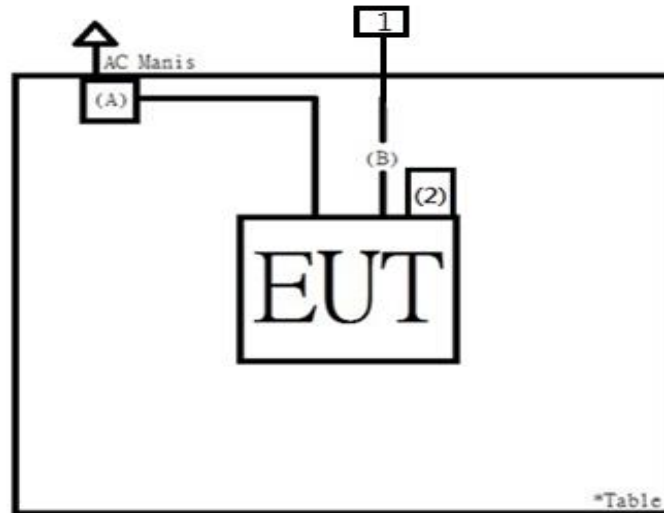

<Mains Conducted Emission mode>

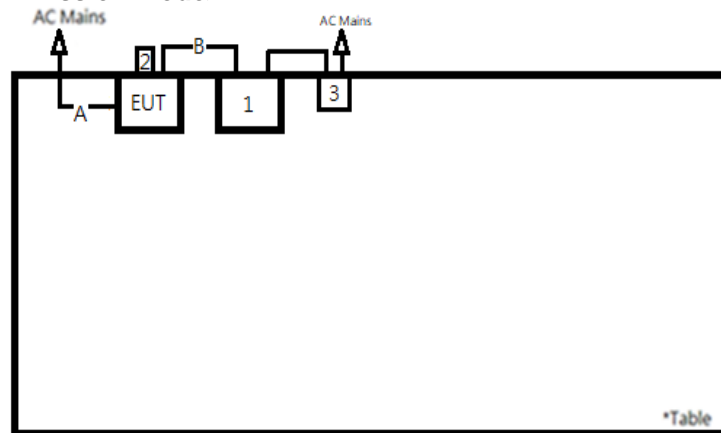

4.6 Duty Cycle of Test Signal

Mode	On + Off Time (ms)	On Time (ms)	Duty Cycle (%)	Duty Factor (dB)
802.11b	8.48	8.40	99.01	0.04
802.11g	1.46	1.40	95.88	0.18
802.11ax HE20	0.37	0.31	84.28	0.74
802.11ax HE40	0.37	0.31	84.28	0.74

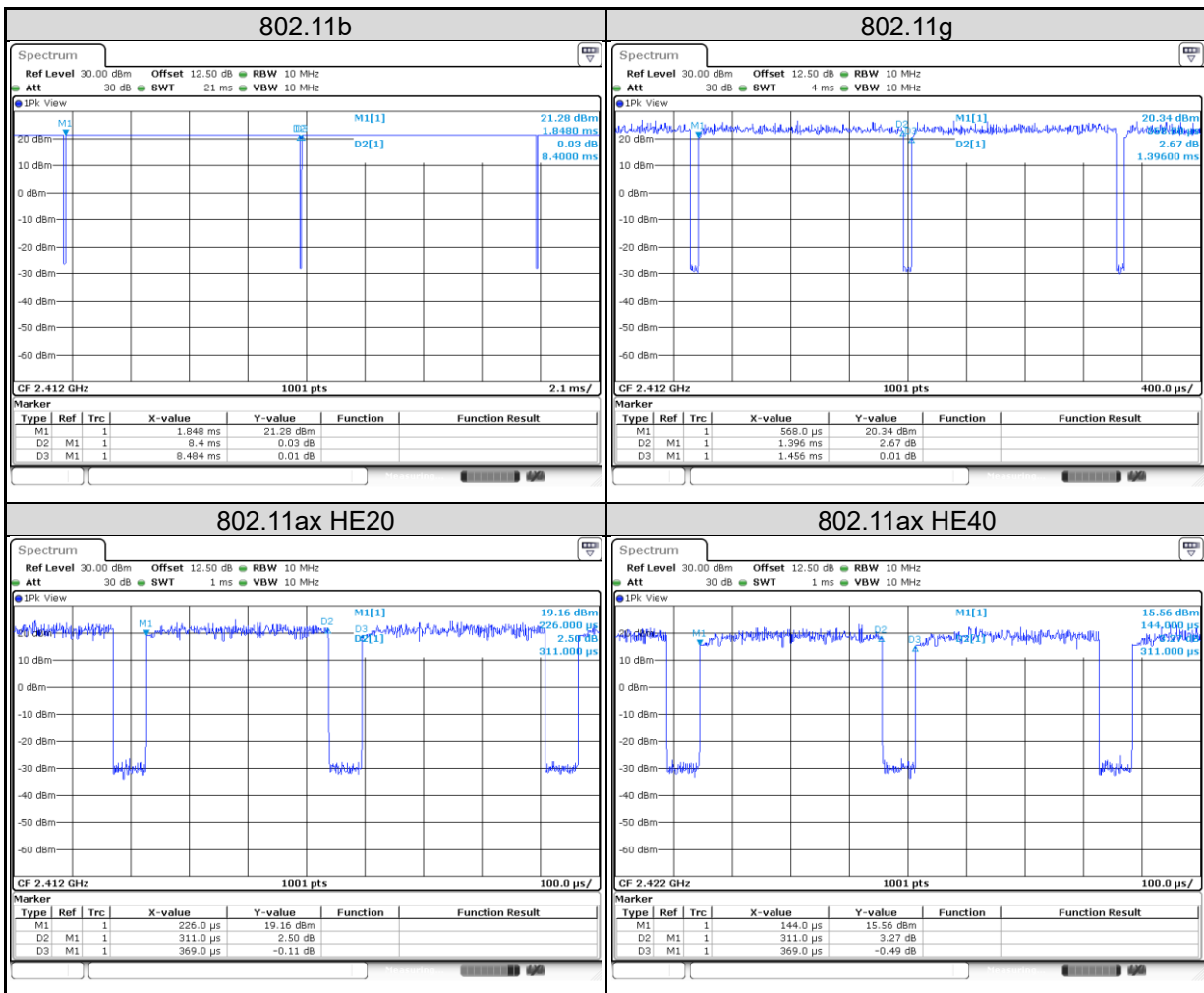

5. Test Results

5.1 Transmitter Requirement & Test Suites

5.1.1 Antenna Requirement

Requirement Use of approved antennas only

The gain value is derived from Antenna datasheet, the EUT's antenna specifications are described as below. The antenna is used with no possibility of replacement with a non-approved antenna by the end-user. Therefore, the EUT is considered to comply with this provision.

ANT		Gain (dBi)	Antenna Type
1		3.49	Dipole
2		3.46	Dipole
3		5.38	Dipole
4		5.24	Dipole
Max Peak Gain		5.38	-
CDD Mode	Power Directional Gain	5.38	-
	PSD Directional Gain	10.46	-
Beamforming Mode	Power Directional Gain	10.46	-
	PSD Directional Gain	10.46	-

Note: PSD Directional Gain = $10\log[(10^{G1/20} + 10^{G2/20} + \dots + 10^{GN/20})^2 / N_{ANT}]$

Refer to EUT photo for details.

Prüfbericht - Nr.: CN246337 001
Test Report No.

 Seite 19 von 32
 Page 19 of 32

5.1.2 Peak Output Power

Limit 1 watt (30 dBm)

Kind of Test Site Shielded room

Test Setup

Test Instruments

Kind of Equipment	Manufacturer	Type	S/N	Calibration Date	Calibration Due Date	Test Date	
						From	Until
Power Meter	Anritsu	ML2495A	1901008	2024/03/12	2025/03/12	2024/3/27	2024/4/29
Power Sensor	Anritsu	MA2411B	1725269	2024/03/12	2025/03/12	2024/3/27	2024/4/29

Test Procedures

Average power sensor was used to perform output power measurement, trigger and gating function of wide band power meter is enabled to measure max output power of TX on burst. Duty factor is not added to measured value.

Test Result
Average Output Power
CDD Mode
<802.11b>

Channel	Channel Frequency (MHz)	Average Output Power (dBm)				Total Power		Limit (dBm)
		Chain 0	Chain1	Chain 2	Chain 3	(dBm)	(mW)	
1	2412	17.56	17.17	17.30	17.36	23.37	217.29	30
6	2437	18.82	18.68	18.12	18.71	24.61	289.16	30
11	2462	18.04	17.98	17.38	17.85	23.84	242.14	30

<802.11g>

Channel	Channel Frequency (MHz)	Average Output Power (dBm)				Total Power		Limit (dBm)
		Chain 0	Chain1	Chain 2	Chain 3	(dBm)	(mW)	
1	2412	18.05	17.90	17.99	17.97	24.00	251.10	30
2	2417	20.06	19.88	19.94	19.91	25.97	395.24	30
3	2422	22.62	22.60	22.52	22.48	28.58	720.44	30
6	2437	23.88	23.80	23.38	23.81	29.74	942.43	30
10	2457	22.44	22.49	21.88	22.17	28.27	671.79	30
11	2462	19.96	19.77	19.27	19.57	25.67	369.03	30

<802.11n HT20>

Channel	Channel Frequency (MHz)	Average Output Power (dBm)				Total Power		Limit (dBm)
		Chain 0	Chain1	Chain 2	Chain 3	(dBm)	(mW)	
1	2412	17.34	17.30	17.22	17.12	23.27	212.15	30
2	2417	18.98	18.62	18.64	18.83	24.79	301.34	30
3	2422	20.34	20.36	20.26	20.41	26.36	432.86	30
4	2427	21.77	21.89	21.72	21.77	27.81	603.75	30
6	2437	23.27	23.32	22.84	23.23	29.19	829.79	30
8	2447	21.79	21.69	21.21	21.77	27.64	581.02	30
9	2452	20.88	20.68	20.12	20.68	26.62	459.16	30
10	2457	20.22	20.14	19.54	19.95	25.99	397.28	30
11	2462	17.20	17.01	16.46	17.02	22.95	197.32	30

Prüfbericht - Nr.: CN246337 001
Test Report No.

 Seite 21 von 32
 Page 21 of 32

<802.11n HT40>

Channel	Channel Frequency (MHz)	Average Output Power (dBm)				Total Power		Limit (dBm)
		Chain 0	Chain1	Chain 2	Chain 3	(dBm)	(mW)	
3	2422	12.06	11.80	12.14	11.99	18.02	63.39	30
4	2427	12.14	11.72	12.05	11.87	17.97	62.64	30
5	2432	16.44	16.44	16.67	16.46	22.52	178.82	30
6	2437	17.93	17.81	17.43	17.73	23.75	237.11	30
8	2447	16.81	16.70	16.47	16.56	22.66	184.40	30
9	2452	13.60	13.40	13.23	13.50	19.46	88.21	30

<802.11ax HE20>

Channel	Channel Frequency (MHz)	Average Output Power (dBm)				Total Power		Limit (dBm)
		Chain 0	Chain1	Chain 2	Chain 3	(dBm)	(mW)	
1	2412	17.56	17.49	17.44	17.31	23.47	222.41	30
2	2417	19.13	18.83	18.87	19.00	24.98	314.75	30
3	2422	20.53	20.55	20.42	20.51	26.52	449.10	30
4	2427	22.02	22.06	21.93	21.99	28.02	634.00	30
6	2437	23.42	23.48	22.97	23.41	29.35	860.06	30
8	2447	22.02	21.88	21.33	21.89	27.81	603.75	30
9	2452	21.01	20.84	20.26	20.79	26.75	473.64	30
10	2457	20.44	20.33	19.79	20.12	26.20	416.64	30
11	2462	17.33	17.19	16.67	17.16	23.12	204.89	30

<802.11ax HE40>

Channel	Channel Frequency (MHz)	Average Output Power (dBm)				Total Power		Limit (dBm)
		Chain 0	Chain1	Chain 2	Chain 3	(dBm)	(mW)	
3	2422	12.26	11.96	12.35	12.14	18.20	66.08	30
4	2427	12.24	11.92	12.21	12.09	18.14	65.12	30
5	2432	16.65	16.58	16.83	16.55	22.67	185.12	30
6	2437	18.06	17.97	17.57	17.84	23.88	244.60	30
8	2447	16.99	16.88	16.65	16.82	22.86	193.08	30
9	2452	13.83	13.59	13.36	13.68	19.64	92.02	30

Beamforming Mode
<802.11ax HE20>

Channel	Channel Frequency (MHz)	Average Output Power (dBm)				Total Power		Limit (dBm)
		Chain 0	Chain1	Chain 2	Chain 3	(dBm)	(mW)	
1	2412	11.54	11.47	11.42	11.29	17.45	55.61	25.54
2	2417	13.11	12.81	12.85	12.98	18.96	78.70	25.54
3	2422	14.51	14.53	14.40	14.49	20.50	112.29	25.54
4	2427	16.00	16.04	15.91	15.97	22.00	158.52	25.54
6	2437	17.40	17.46	16.95	17.39	23.33	215.05	25.54
8	2447	16.00	15.86	15.31	15.87	21.79	150.96	25.54
9	2452	14.99	14.82	14.24	14.77	20.73	118.43	25.54
10	2457	14.42	14.31	13.77	14.10	20.18	104.17	25.54
11	2462	11.31	11.17	10.65	11.14	17.10	51.23	25.54

<802.11ax HE40>

Channel	Channel Frequency (MHz)	Average Output Power (dBm)				Total Power		Limit (dBm)
		Chain 0	Chain1	Chain 2	Chain 3	(dBm)	(mW)	
3	2422	6.24	5.94	6.33	6.12	12.18	16.52	25.54
4	2427	6.22	5.90	6.19	6.07	12.12	16.28	25.54
5	2432	10.63	10.56	10.81	10.53	16.65	46.29	25.54
6	2437	12.04	11.95	11.55	11.82	17.86	61.16	25.54
8	2447	10.97	10.86	10.63	10.80	16.84	48.28	25.54
9	2452	7.81	7.57	7.34	7.66	13.62	23.01	25.54

Prüfbericht - Nr.: CN246337 001
Test Report No.

 Seite 23 von 32
 Page 23 of 32

5.1.3 6 dB Bandwidth and 99% Occupied Bandwidth

Limit The minimum 6 dB bandwidth shall be at least 500 kHz.

Kind of Test Site Shielded room

Test Setup

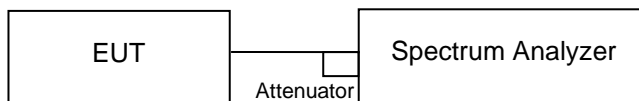

Test Instruments

Kind of Equipment	Manufacturer	Type	S/N	Calibration Date	Calibration Due Date	Test Date	
						From	Until
Spectrum Analyzer	R&S	FSV	101512	2024/02/22	2025/02/20	2024/3/27	2024/4/29

Test Procedure

- a. Set resolution bandwidth (RBW) = 100 kHz
- b. Set the video bandwidth (VBW) $\geq 3 \times$ RBW, Detector = Peak.
- c. Trace mode = max hold.
- d. Sweep = auto couple.
- e. Measure the maximum width of the emission that is constrained by the frequencies associated with the two amplitude points (upper and lower) that are attenuated by 6 dB relative to the maximum level measured in the fundamental emission.
- f. For 99% occupied bandwidth measurement, the transmitter output was connected to the spectrum analyzer through an attenuator. The bandwidth of the fundamental frequency was measured by spectrum analyzer with resolution bandwidth in the range of 1% to 5% of the anticipated emission bandwidth, and a video bandwidth at least 3x the resolution bandwidth and set the detector to PEAK. The width of a frequency band such that, below the lower and above the upper frequency limits, the mean powers emitted are each equal to a specified percentage 0.5% of the total mean power of a given emission.

Test Results

Please refer to Appendix A.

5.1.4 Power Spectral Density

Limit

The power spectral density shall not be greater than 8 dBm in any 3 kHz band.

Kind of Test Site Shielded room

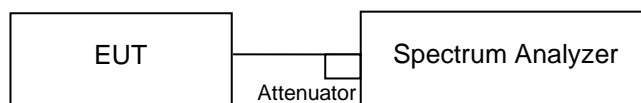
Test Setup

Test Instruments

Kind of Equipment	Manufacturer	Type	S/N	Calibration Date	Calibration Due Date	Test Date	
						From	Until
Spectrum Analyzer	R&S	FSV	101512	2024/02/22	2025/02/20	2024/3/27	2024/4/29

Test Procedure

- a. Set instrument center frequency to DTS channel center frequency.
- b. Set span to at least 1.5 times the OBW.
- c. Set RBW to: $3 \text{ kHz} \leq \text{RBW} \leq 100 \text{ kHz}$.
- d. Set $\text{VBW} \geq [3 \times \text{RBW}]$.
- e. Detector = power averaging (rms) or sample detector (when rms not available).
- f. Ensure that the number of measurement points in the sweep $\geq [2 \times \text{span} / \text{RBW}]$.
- g. Sweep time = auto couple
- h. Do not use sweep triggering; allow sweep to “free run.”
- i. Employ trace averaging (rms) mode over a minimum of 100 traces.
- j. Use the peak marker function to determine the maximum amplitude level.
- k. Add $[10 \log (1 / D)]$, where D is the duty cycle measured in step a), to the measured PSD to compute the average PSD during the actual transmission time. If measured value exceeds requirement specified by regulatory agency, then reduce RBW (but no less than 3 kHz) and repeat (note that this may require zooming in on the emission of interest and reducing the span to meet the minimum measurement point requirement as the RBW is reduced).

Test Results

Please refer to Appendix A.

Prüfbericht - Nr.: CN246337 001
Test Report No.

 Seite 25 von 32
 Page 25 of 32

5.1.5 Conducted Spurious Emissions and Frequency Band Edges Measured in 100 kHz Bandwidth

Limit

30 dB (below that in the 100 kHz bandwidth within the band that contains the highest level of the desired power.)

Kind of Test Site Shielded room

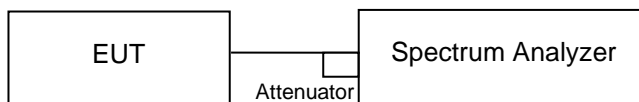
Test Setup

Test Instruments

Kind of Equipment	Manufacturer	Type	S/N	Calibration Date	Calibration Due Date	Test Date	
						From	Until
Spectrum Analyzer	R&S	FSV	101512	2024/02/22	2025/02/20	2024/3/27	2024/4/29

Test Procedure

Measurement procedure REF

1. Set the RBW = 100 kHz.
2. Set the VBW \geq 300 kHz.
3. Detector = peak.
4. Sweep time = auto couple.
5. Trace mode = max hold.
6. Allow trace to fully stabilize.
7. Use the peak marker function to determine the maximum power level in any 100 kHz band segment within the fundamental EBW.

Measurement procedure OOBE

1. Set RBW = 100 kHz.
2. Set VBW \geq 300 kHz.
3. Detector = peak.
4. Sweep = auto couple.
5. Trace Mode = max hold.
6. Allow trace to fully stabilize.
7. Use the peak marker function to determine the maximum amplitude level.

Test Results

Please refer to Appendix A.

5.1.6 Radiated Spurious Emissions and Band Edges

Limit

Radiated emissions which fall in the restricted bands, as defined in §15.205(a), must comply with the radiated emission limits specified in §15.209(a).

Emissions radiated outside the restricted and authorized frequency bands must either comply with the radiated emission limits specified for the restricted bands or in §15.247(d).

Kind of Test Site 3m Semi-Anechoic Chamber

Test Setup

<Radiated Emissions below 30 MHz>

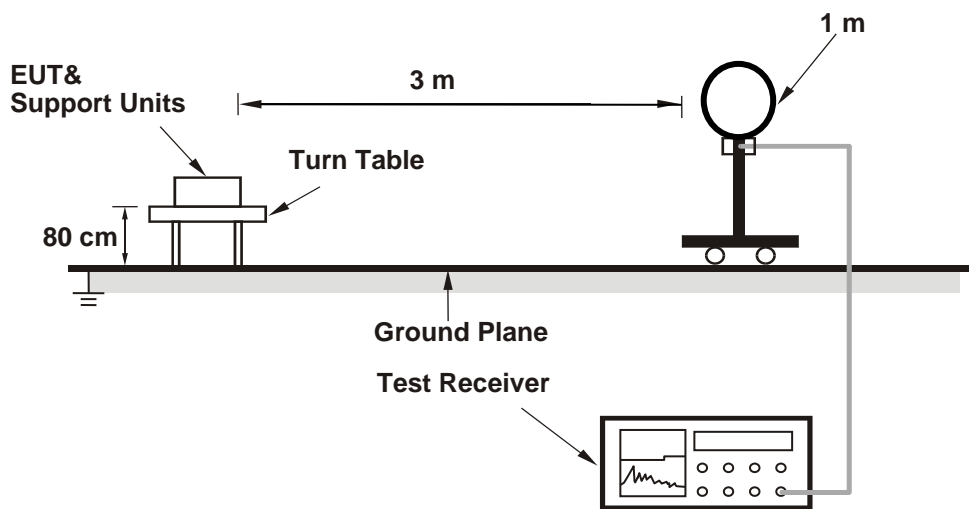

<Radiated Emissions 30 MHz to 1 GHz>

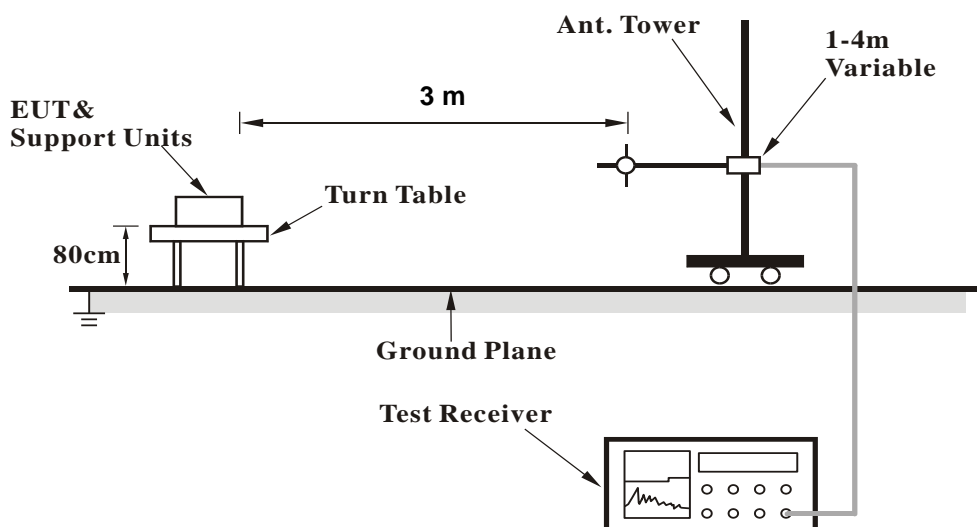

<Radiated Emissions above 1 GHz>

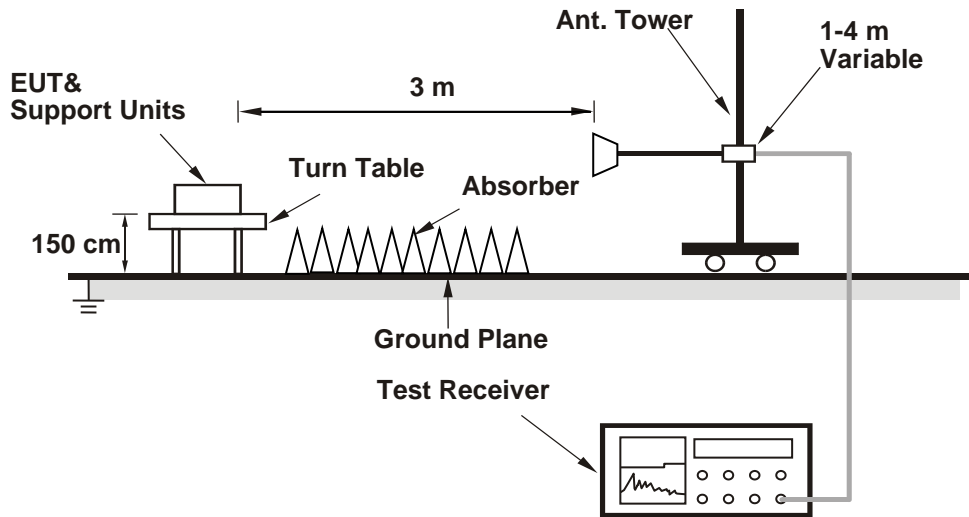

For the actual test configuration, please refer to the attached file (Test Setup Photo).

Prüfbericht - Nr.: CN246337 001
Test Report No.

 Seite 28 von 32
 Page 28 of 32

Test Instruments

Kind of Equipment	Manufacturer	Type	S/N	Calibration Date	Calibration Due Date
Above 1 GHz (Tested Period: 2024-03-28 ~ 2024-04-01)					
Signal Analyzer	R&S	FSV40	101509	2023/4/26	2024/4/24
Horn Antenna	ETS-Lindgren	3117	00218931	2024/2/22	2025/2/20
HF-AMP + AC source	EMCI	EM01G18GA	980633	2024/1/24	2025/1/22
HF-AMP + AC source	EMCI	EMC184045SE	980657	2024/1/24	2025/1/22
Horn Antenna	SCHWARZBECK	BBHA 9170	00890	2023/5/4	2024/5/2
Test Software	Audix E3	15914a_20191106 tuv	PK-001087	N/A	N/A
30 MHz ~ 1 GHz (Tested Period: 2024-04-09)					
Receiver	R&S	ESR7	102109	2024/2/23	2025/2/21
Bilog Antenna	SCHWARZBECK	VULB-9168	00951	2024/3/29	2025/3/28
LF-AMP	Agilent	8447D	2944A107722	2024/3/20	2025/3/19
Test Software	Audix E3	15914a_20191106 tuv	PK-001087	N/A	N/A
Below 30 MHz (Tested Period: 2024-04-09)					
Receiver	R&S	ESR7	102109	2024/2/23	2025/2/21
Loop Antenna	SCHWARZBECK	FMZB 1519B	00215	2024/1/4	2025/1/3
Test Software	Audix E3	15914a_20191106 tuv	PK-001087	N/A	N/A

Test Procedures**For Radiated Emissions below 30 MHz**

- a. The EUT was placed on the top of a rotating table 0.8 meters above the ground at a 3 meter chamber room. The table was rotated 360 degrees to determine the position of the highest radiation.
- b. The EUT was set 3 meters away from the interference-receiving antenna, which was mounted on the top of a variable-height antenna tower.
- c. Parallel (OPEN), perpendicular (CLOSE), and ground-parallel (GROUND) orientations of the antenna are set to make the measurement.
- d. For each suspected emission, the EUT was arranged to its worst case and the rotatable table was turned from 0 degrees to 360 degrees to find the maximum reading.
- e. The test-receiver system was set to Quasi-Peak Detect Function and Specified Bandwidth with Maximum Hold Mode.

Note:

1. The resolution bandwidth and video bandwidth of test receiver/spectrum analyzer is 9 kHz at frequency below 30 MHz.
2. All modes of operation were investigated and the worst-case emissions are reported.

For Radiated Emissions above 30 MHz

- a. The EUT was placed on the top of a rotating table 0.8 meters (for 30 MHz ~ 1 GHz) / 1.5 meters (for above 1 GHz) above the ground at 3 meter chamber room for test. The table was rotated 360 degrees to determine the position of the highest radiation.
- b. The EUT was set 3 meters away from the interference-receiving antenna, which was mounted on the top of a variable-height antenna tower.
- c. The height of antenna is varied from one meter to four meters above the ground to determine the maximum value of the field strength. Both horizontal and vertical polarizations of the antenna are set to make the measurement.
- d. For each suspected emission, the EUT was arranged to its worst case and then the antenna was tuned to heights from 1 meter to 4 meters and the rotatable table was turned from 0 degrees to 360 degrees to find the maximum reading.
- e. The test-receiver system was set to quasi-peak detect function and specified bandwidth with maximum hold mode when the test frequency is below 1 GHz.
- f. The test-receiver system was set to peak and average detected function and specified bandwidth with maximum hold mode when the test frequency is above 1 GHz. If the peak reading value also meets average limit, measurement with the average detector is unnecessary.

Note:

1. The resolution bandwidth and video bandwidth of test receiver/spectrum analyzer is 120 kHz for Quasi-peak detection (QP) or Peak detection (PK) at frequency below 1 GHz.
2. The resolution bandwidth of test receiver/spectrum analyzer is 1 MHz and the video bandwidth is 3 MHz for Peak detection (PK) at frequency above 1 GHz.
3. The resolution bandwidth of test receiver/spectrum analyzer is 1 MHz and the video bandwidth is $\geq 1/T$ (Duty cycle < 98 %) or 10 Hz (Duty cycle ≥ 98 %) for Average detection (AV) at frequency above 1 GHz.
4. All modes of operation were investigated and the worst-case emissions are reported.
5. The Radiated Emissions testing was performed in the X(E1), Y(H) and Z(E2) axis orientation. The worst-case Axis orientation is recorded in this test report.
6. The emission levels of other frequencies (including the 10th harmonic of the highest fundamental frequency) are very lower than the limit and are not shown in the test report.

Prüfbericht - Nr.: **CN246337 001**
Test Report No.

Seite 30 von 32
Page 30 of 32

Test Results

Factor (dB/m) = Antenna Factor (dB/m) + Cable Loss (dB) – Amplifier (dB)

Level (dBuV/m) = Reading (dBuV) + Factor (dB/m)

Please refer to Appendix B.

5.2 Mains Emission

5.2.1 Mains Conducted Emission

Limit

Mains Conducted Emission as defined in §15.207 must comply with the mains conducted emission limits.

Kind of Test Site Shielded room

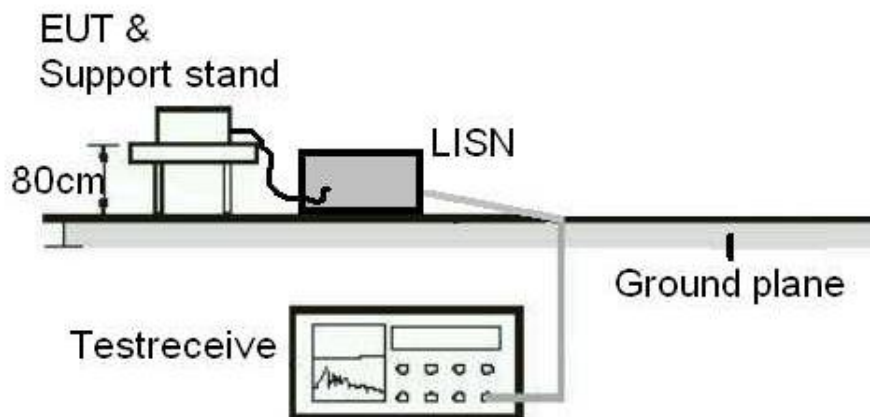
Test Setup

Test Instruments

Kind of Equipment	Manufacturer	Type	S/N	Calibration Date	Calibration Due Date
Two-Line V-Network	Rohde & Schwarz	ENV216	101938	2023/10/23	2024/10/21
EMI Test Receiver	R&S	ESCI	100797	2023/7/21	2024/7/19

Prüfbericht - Nr.: CN246337 001
*Test Report No.*Seite 32 von 32
Page 32 of 32**Test Procedures**

- a. The EUT was placed 0.4 meters from the conducting wall of the shielded room with EUT being connected to the power mains through a line impedance stabilization network (LISN). Other support units were connected to the power mains through another LISN. The two LISNs provide 50 ohm/50 uH of coupling impedance for the measuring instrument.
- b. Both lines of the power mains connected to the EUT were checked for maximum conducted interference.
- c. The frequency range from 150 kHz to 30 MHz was searched. Emission levels under (Limit – 20 dB) was not recorded.

Note: The resolution bandwidth and video bandwidth of test receiver is 9 kHz for quasi-peak detection (QP) and average detection (AV) at frequency 0.15 MHz – 30 MHz.

Test Results

Please refer to Appendix B.