

供方 LOGO 和名称:



东莞市仁丰电子科技有限公司

Dongguan RF Electronic Technology Co., Ltd

公司地址: 东莞市塘厦镇清湖头三坑工业区1号 电话: 0769-38940168 传真: 0769-39010966 网址: <http://rflink.net.cn>

规格承认书

SPECIFICATION FOR APPROVAL

客户名称 (CUSTOMER)	广东九联科技股份有限公司
客户型号 (MODEL NO)	(由九联填写)
客户料号 (PART NO)	(由九联填写)
供方型号 (MODEL NO)	(由供方填写)
供方料号 (PART NO)	U00T01S040N04823 (由供方填写)
最小包装量 (MPQ)	20 (由供方填写)
品牌 (BRAND)	Rf link (由供方填写)
送样日期 (DATE)	2023/12/22 (由供方填写)
样品数量 (QUANTITY)	30 (由供方填写)

供方确认			客户确认		
APPROVED SIGNATURES			APPROVED SIGNATURES		
承办	审核	核准	检测	审核	核准
PREPARED BY	CHECKED BY	APPROVED BY	TESTED BY	CHECKED BY	APPROVED BY

备注: 承认书一式一份; 送样时由供方**手工签名和加盖公司公章**

地址: 广东省东莞市塘厦镇清湖头三坑路一号

电 话: 0769-38940168 传真: 0769-39010966

联系人: 韦良松 手机: 18877417721

电子邮箱: SevlynWei@rflink.net.cn

公司网址: www.rflink.net.cn

承 认 书

SPECIFICATION FOR APPROVAL

客户名称

CUSTOMER NAME: 九联

产品名称

PRODUCT NAME: 5G 外露L=300MM

客户料号

CUSTOMER P/N:

仁丰料号

Ren Feng P/N: U00T01S040N04823 REV: A

内部结构

Internal structure: PCB

	MANUFACTURER SIGNATURE	CUSTOMER SIGNATURE
CHECKED BY:	杨振	
AUDITOR BY:	肖玉鹏	
APPROVED BY:	姚定军	
DATE:	2023-12-08	



东莞市仁丰电子科技有限公司

Dongguan RF Electronic Technology Co., Ltd

公司地址: 东莞市塘厦镇清湖头三坑工业区1号 电话: 0769-38940168 传真: 0769-39010966 网址: <http://www.rflink.net.cn>

Contents

<i>Description</i>	<i>Page</i>
1、封面 Cover -----	1
2、履历表 Resume -----	2
3、目录 Contents-----	3
4、规格表 Specifications sheets -----	4
5、成品图 End product chart -----	5
6、测试报告 Testing report -----	6-10

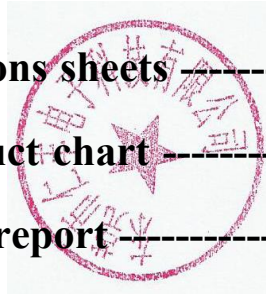

产品主要技术参数

主要技术指标		Main technical specifications	
频率范围 (MHZ)	5150-5850	Frequency Range (MHZ)	5150-5850
中心频率 特性阻抗(Ω)	50	Impedance(Ω)	50
增益(dBi)	4.74	Gain(dBi)	4.74
反射损耗	≤ -9.5	Return Loss(dB)	≤ -9.5
输出电压 驻波比	≤ 2.0	VSWR	≤ 2.0
极化方式	垂直极化	Polarization	Linear, Vertical
方向性	全向性	Radiation	Omni-directional
连接方式	端子	Connector Type	MHF Plug
物理性能		Physical Properties	
天线本体材 料	PC+ABS	Antenna Base	PC+ABS
工作温度	$-20^{\circ}\text{C} \sim +60^{\circ}\text{C}$	Operating Temp	$-20^{\circ}\text{C} \sim +60^{\circ}\text{C}$
保存温度	$-20^{\circ}\text{C} \sim +70^{\circ}\text{C}$	Storage Temp	$-20^{\circ}\text{C} \sim +70^{\circ}\text{C}$

REV	DATE	DESCRIPTION
A	2023-12-08	NEW ISSUE

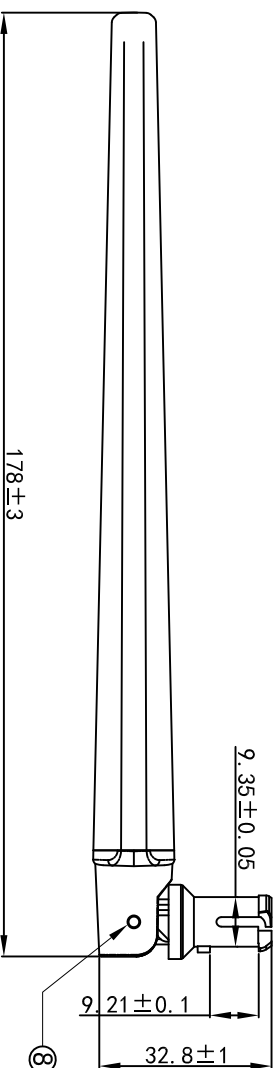
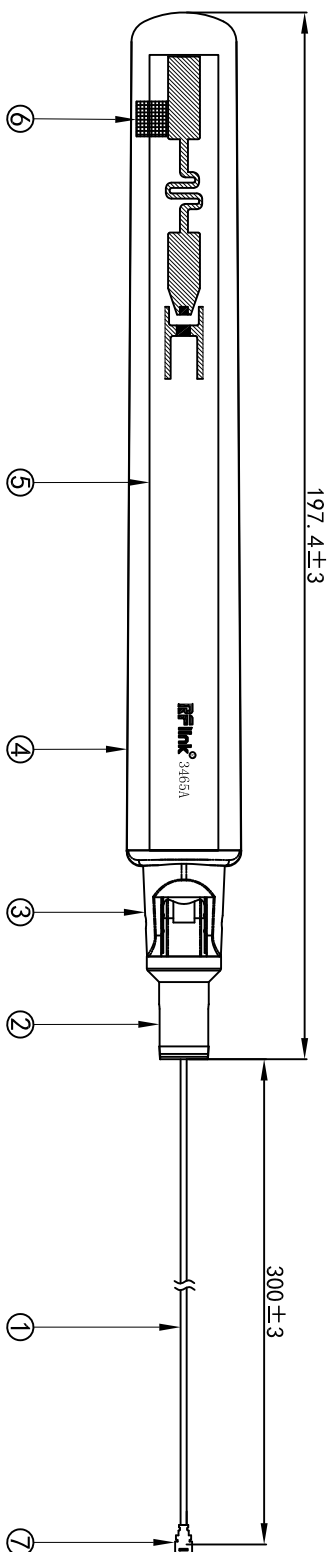

规格 (Specification) :
 频率 (Frequency Range) : 5.15~5.85GHz
 回波损耗 (Return loss) : -9.5dB or less
 驻波比 (VSWR) : 2.0max

8	铆钉	2	POM; Black
7	端子	1	Copper
6	泡棉	1	EVA; Black
5	POB板	1	FR-4
4	杆套	1	PC+ABS; Black
3	上固定座	1	ABS; Black
2	下固定座	1	PC+PBT; Black
1	线材	1	Ø1.37 Gray
NO.	DESCRIPTION	Q'TY	REMARK

尺寸范围 (mm)	公差 (mm)	APPROVED
0<L≤6	±0.10	
6<L≤30	±0.10	
30<L≤90	±0.15	
90<L≤180	±0.20	CHECKED
180<L≤315	±0.25	
315<L≤800	±0.35	
角度	±0.5°	DRAWING

CUSTOMER:			
PART NO. :			
PARTNAME : RF Antenna Assembly			
R.F P/NO : U00T01S040N04822			
REV	UNIT	SCALE	SHEET
A	mm	1:1	A4

RF link
 东莞市仁丰电子科技有限公司
 RenFeng Electronic
 technology Co., LTD.

带公差尺寸为检验尺寸
 产品符合环保RoHS2.0之要求

ANT6-5G回波损耗与电压驻波比VSWR

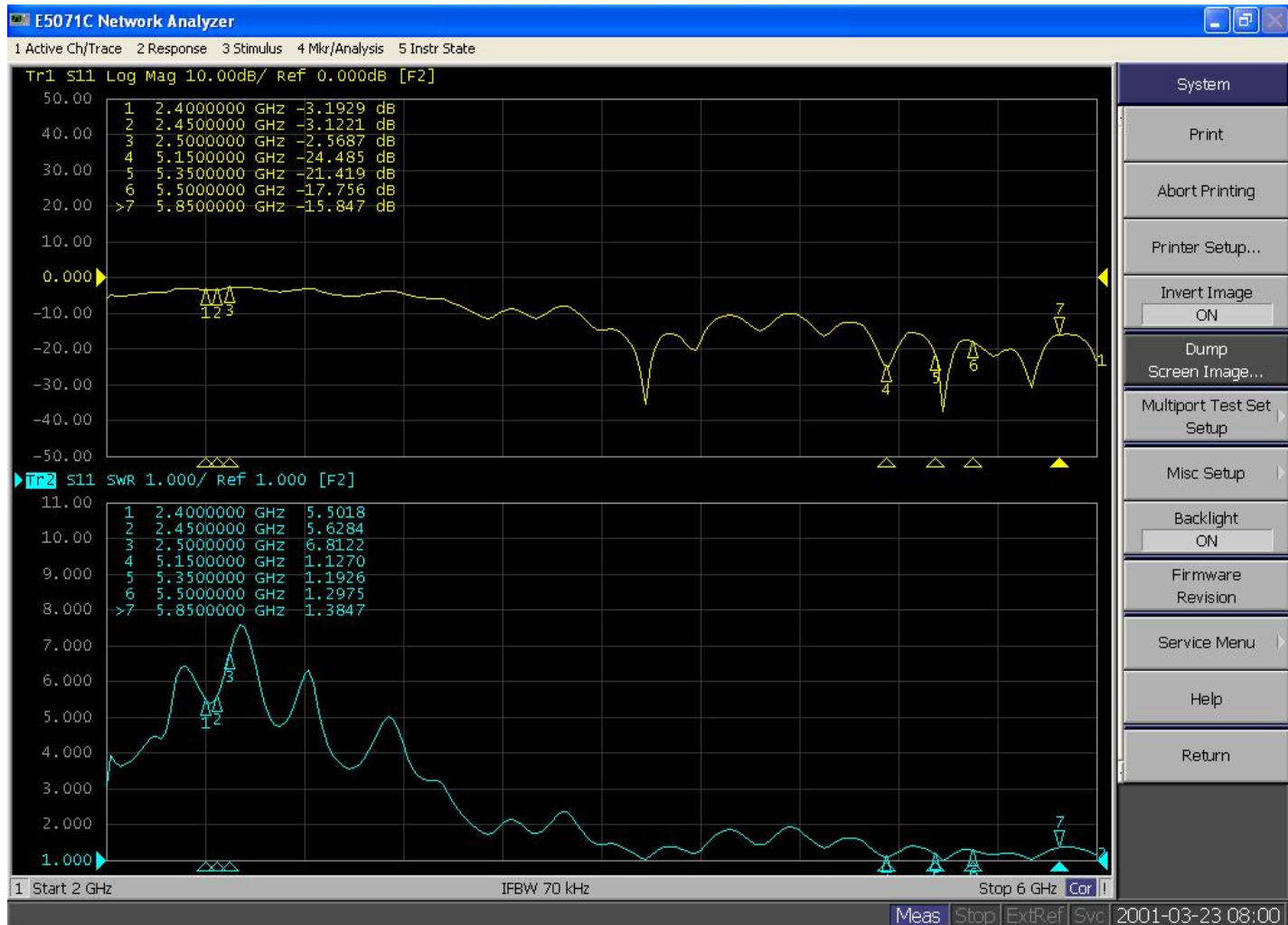

AX6000 Project

2D/3D Pattern

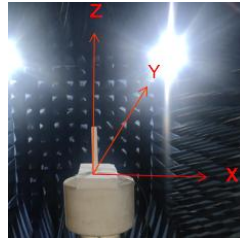

H面: XY (水平面)

E1面: XZ

E2面: YZ

远场方向图

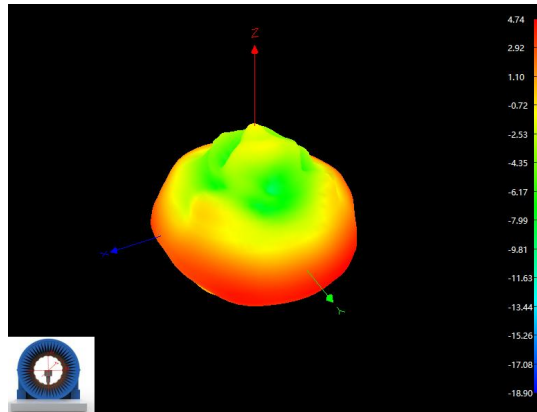

5G-ANT6
5150MHz

E1面

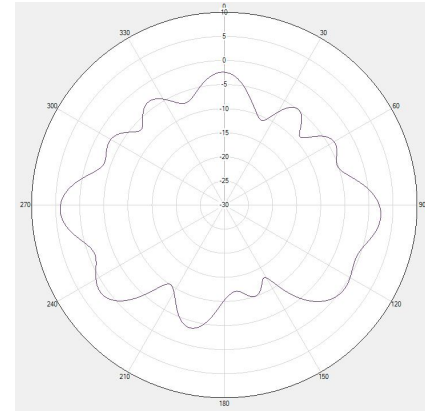

E2面

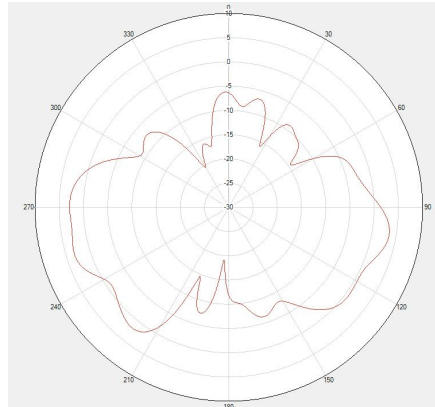

H面

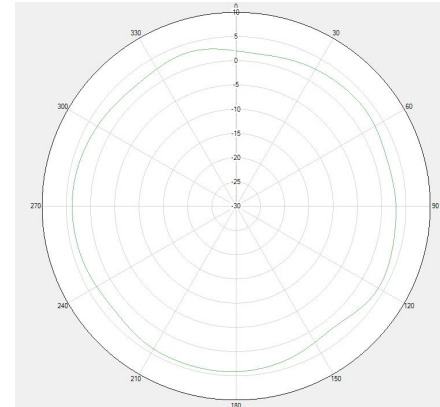

AX6000 Project

2D/3D Pattern

H面: XY (水平面)

E1面: XZ

E2面: YZ

远场方向图

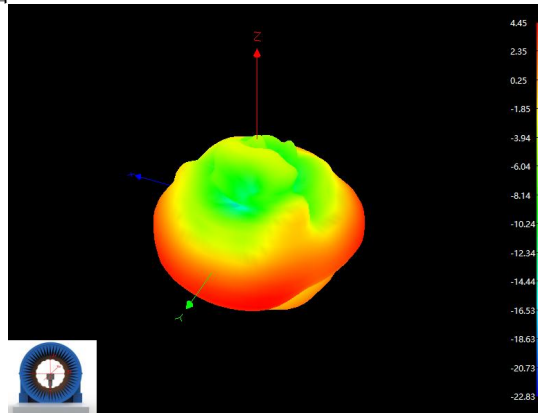

5G-ANT6
5500MHz

E1面

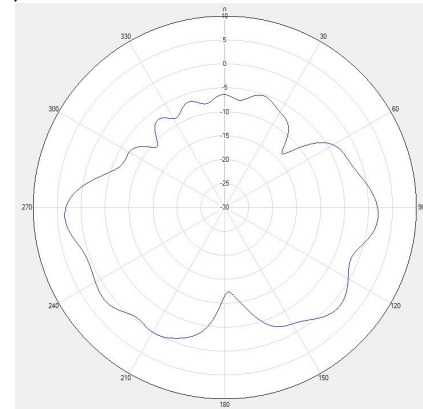

E2面

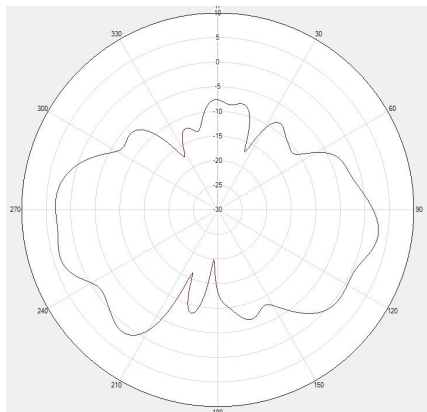

H面

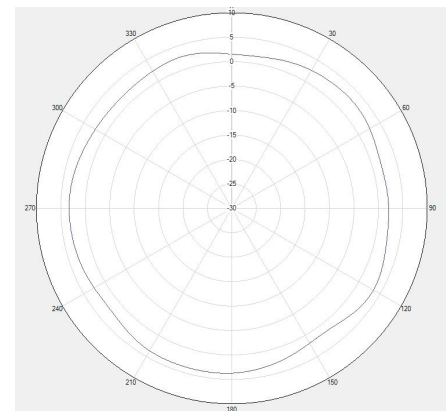

AX6000 Project

2D/3D Pattern

H面: XY (水平面)

E1面: XZ

E2面: YZ

远场方向图

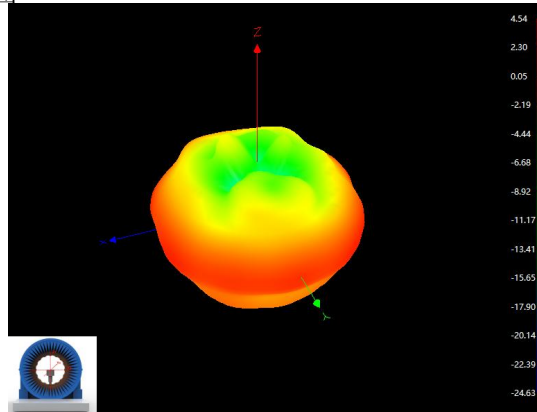

5G-ANT6
5850MHz

E1面

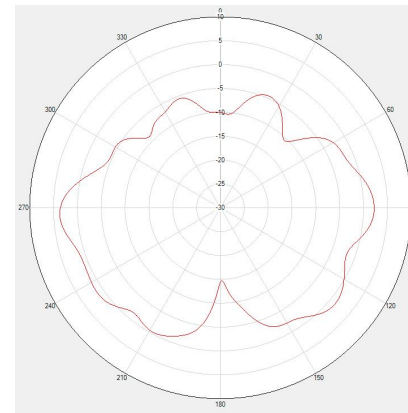

E2面

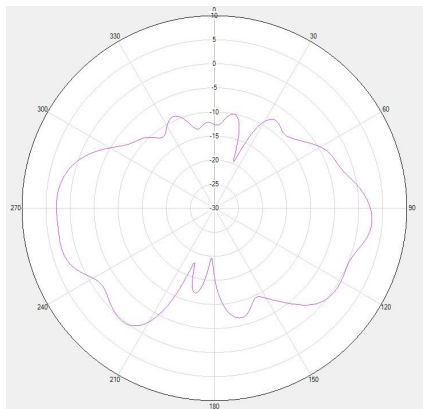

H面

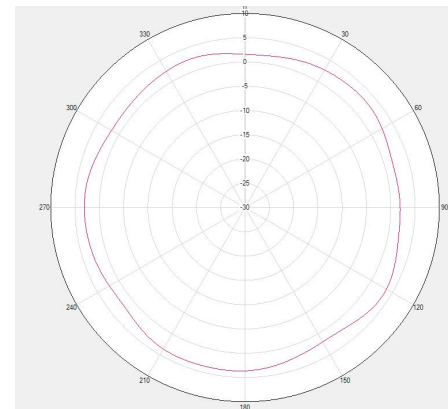



AX6000 Project

Peak Gain

	5G_ANT6	
Freq (MHz)	Effi (%)	Gain (dBi)
5150	72.72	4.74
5200	68.28	4.29
5250	73.81	4.33
5300	69.48	4.28
5350	72.58	4.34
5400	74.33	4.45
5450	75.21	4.21
5500	73.23	4.45
5550	71.23	4.25
5600	66.98	4.23
5650	72.39	4.29
5700	67.70	4.35
5750	74.83	4.48
5800	71.09	4.28
5850	72.68	4.54

OTA测试结果

2.4G							
Mode	Test Case	Channel	Date Rate (Mbps)	ANT1 Test Results (dBm)	ANT2 Test Results (dBm)	ANT3 Test Results (dBm)	ANT4 Test Results (dBm)
IEEE 802.11g	TRP (Total)	1	6	22.41	22.57	22.81	21.47
		6		22.50	21.37	21.78	21.38
		11		21.46	21.31	21.54	21.16
	TIS (Total)	1	54	-78.06	-78.08	-78.32	-77.24
		6		-78.60	-78.56	-78.24	-78.11
		11		-78.39	-78.35	-78.05	-77.68

5G							
Mode	Test Case	Channel	Date Rate (Mbps)	ANT1 Test Results (dBm)	ANT2 Test Results (dBm)	ANT5 Test Results (dBm)	ANT6 Test Results (dBm)
IEEE 802.11a	TRP (Total)	36	6	21.54	22.37	21.38	21.92
		149		20.65	21.21	21.66	21.88
		161		20.31	21.15	21.80	21.74
	TIS (Total)	36	54	-76.45	-76.36	-76.85	-76.69
		149		-75.88	-75.44	-76.82	-76.21
		161		-75.15	-75.05	-76.13	-76.35