

Quick Start Guide  
Kurzanleitung  
Guida introduttiva  
Guide de démarrage rapide  
Guia rápida de inicio  
Skrócona instrukcja obsługi  
Stručná referenční příručka  
Guia de início rápido  
Guia de Inicialização rápida  
快速入門指南

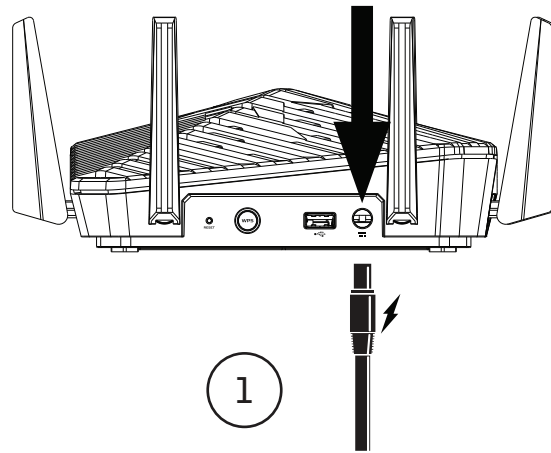

1

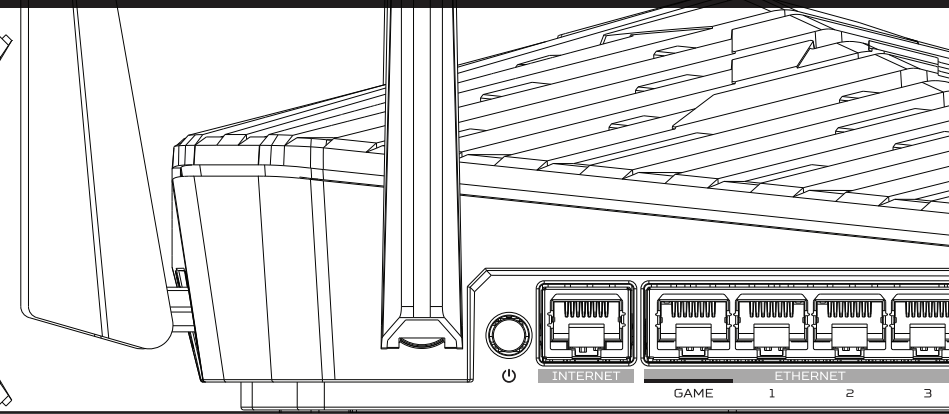
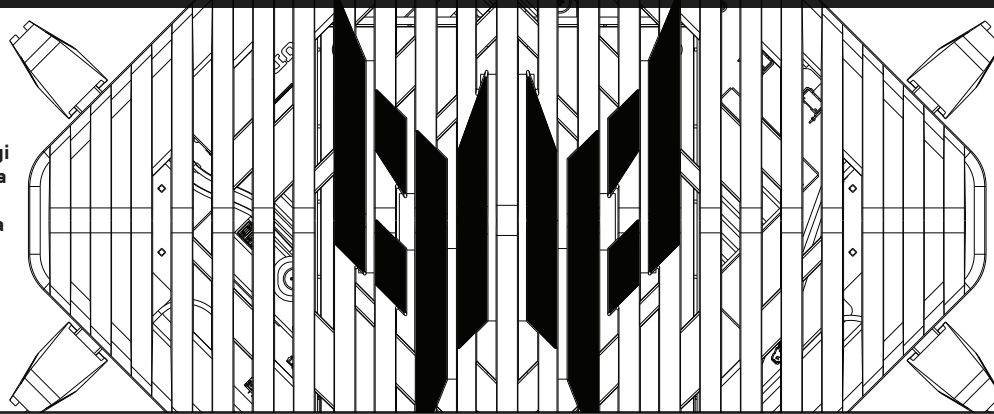
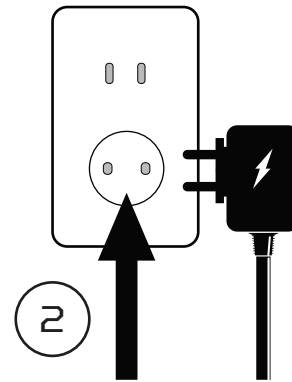

2

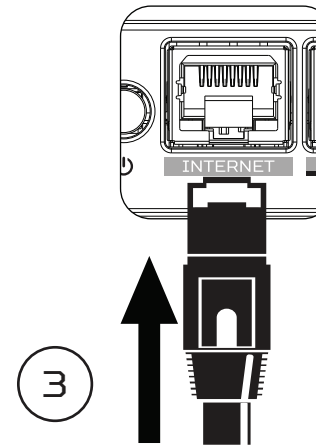

3

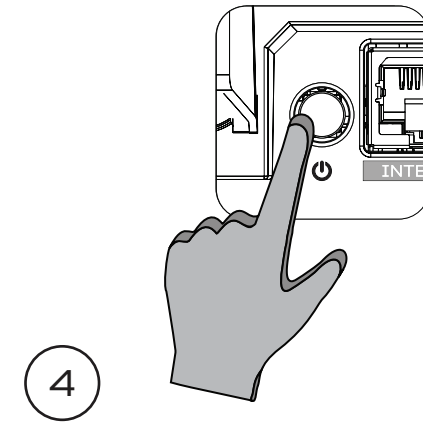

4

1. Plug in AC adapter.
1. Stecken Sie das Netzteil ein.
1. Branchez l'adaptateur secteur.
1. Conecte el adaptador de CA.
1. Collegare l'adattatore CA.
1. Ligue o transformador AC.
1. Podłącz zasilacz prądu zmiennego.
1. Připojte síťový adaptér.
1. 插入 AC 變壓器。
1. Dugja be a hálózati adaptert.
1. Sluit de wisselstroomadapter aan.
1. Liitä verkkolaite.
1. Tilslut vekselstrømsadapteren (AC).
1. Plugg inn strømadapteren.
1. Koppla in AC-adapttern.

2. Plug into outlet.
2. Schließen Sie es an die Steckdose an.
2. Branchez dans la prise.
2. Conéctelo a la toma de corriente.
2. Inserire nella presa.
2. Ligue à tomada elétrica.
2. Podłącz do gniazda zasilania.
2. Připojte do elektrické zásuvky.
2. 插入插座。
2. Dugja be a konnektorba.
2. Steek de stecker in het stopcontact.
2. Liitä pistorasiaan.
2. Slut den til stikkontakten.
2. Plugg inn i stikkkontakten.
2. Anslut i ett uttag.

3. Plug in internet cable.
3. Schließen Sie das Internetkabel an.
3. Branchez le câble Internet.
3. Conecte el cable de Internet.
3. Collegare il cavo Internet.
3. Ligue o cabo de Internet.
3. Podłącz kabel internetowy.
3. Připojte internetový kabel.
3. 插入網際網路纜線。
3. Csatlakoztassa az internetkábel.
3. Sluit de internetkabel aan.
3. Liitä internet-kaapeli.
3. Tilslut internetkablet.
3. Plugg inn internetkabelen.
3. Koppla in internetkabeln.

4. Power on device.
4. Schalten Sie das Gerät ein.
4. Mettez l'appareil sous tension.
4. Encienda el dispositivo.
4. Accendere il dispositivo.
4. Ligue o dispositivo.
4. Włącz zasilanie urządzenia.
4. Zapněte napájení zařízení.
4. 開啟裝置電源。
4. Kapcsolja be a készüléket.
4. Schakel het apparaat in.
4. Käynnistä laite.
4. Tænd enheden.
4. Slå på enheten.
4. Slå på enheten.



Download APP

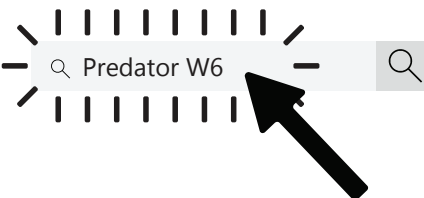

Disclaimer



Please update your computer's WiFi drivers.  
 Bitte aktualisieren Sie die WLAN-Treiber Ihres Computers.  
 Veuillez mettre à jour les pilotes WiFi de votre ordinateur.  
 Actualice los controladores WiFi de su ordenador.  
 Aggiornare i driver Wi-Fi del computer.  
 Atualize os controladores WiFi do seu computador.  
 Zaktualizuj sterowniki WiFi komputera.  
 Zaktualizujte ovladače WiFi v počítači.  
 請更新您電腦的 WiFi 驅動程式。  
 Kérjük, frissítse a számítógép WiFi-illesztőprogramjait.  
 Werk de WiFi-stuurprogramma's van de computer bij.  
 Päivitä tietokoneen Wi-Fi-ohjaimet.  
 Opdater Wi-Fi-driverne på din computer.  
 Opdater datamaskinens WiFi-drivere.  
 Uppdatera datorns WiFi-drivrutiner.

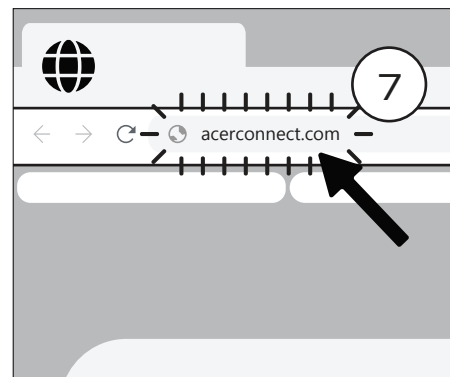
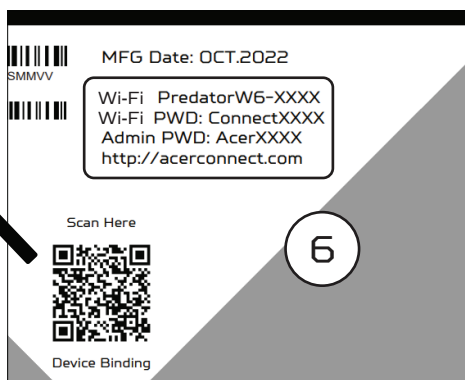
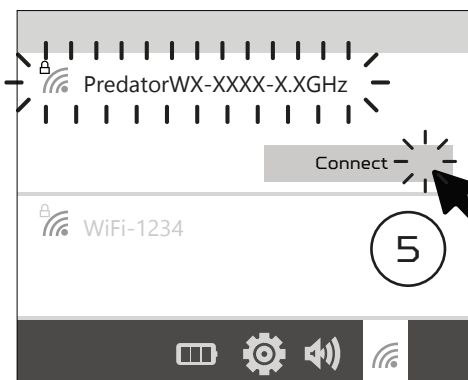

- 5. Connect to PredatorW6 Wi-Fi.
- 5. Stellen Sie eine Verbindung zum PredatorW6-WLAN her.
- 5. Connectez-vous au Wi-Fi PredatorW6.
- 5. Conecte a PredatorW6 Wi-Fi.
- 5. Connettere al Wi-Fi PredatorW6.
- 5. Ligue à rede Wi-Fi PredatorW6.
- 5. Połącz z siecią Wi-Fi PredatorW6.
- 5. Připojte k zařízení PredatorW6 Wi-Fi.
- 5. 連接至 PredatorW6 Wi-Fi。
- 5. Csatlakozzon a PredatorW6 Wi-Fi-hez.
- 5. Maak verbinding met PredatorW6 Wi-Fi.
- 5. Liitä PredatorW6 Wi-Fi-verkkoon.
- 5. Opret en Wi-Fi-forbindelse til PredatorW6.
- 5. Koble til PredatorW6 Wi-Fi.
- 5. Anslut till PredatorW6 WiFi.

- 6. Important info at bottom of device.
- 6. Wichtige Informationen an der Unterseite des Gerätes.
- 6. Informations importantes au bas de l'appareil.
- 6. En la parte inferior del dispositivo hallará información importante.
- 6. Informazioni importanti nella parte inferiore del dispositivo.
- 6. Informações importantes na parte inferior do dispositivo.
- 6. Ważne informacje na spodzie urządzenia.
- 6. Důležité informace na spodní straně zařízení.
- 6. 重要資訊位於裝置底部。
- 6. Fontos információk a készülék alján.
- 6. Belangrijke info op de onderkant van het apparaat.
- 6. Tärkeitä tietoja laitteen pohjassa.
- 6. Der står vigtige oplysninger på bunden af enheden.
- 6. Viktig informasjon nederst på enheten.
- 6. Viktig information på enhetens undersida.

- 7. Enter acerconnect.com to browser.
- 7. Geben Sie acerconnect.com in den Browser ein.
- 7. Entrez acerconnect.com dans le navigateur.
- 7. Escriba acerconnect.com en el navegador.
- 7. Immettere acerconnect.com nel browser.
- 7. Aceda a acerconnect.com para navegar.
- 7. Wprowadź w przeglądarce adres acerconnect.com.
- 7. Do prohlížeče zadejte adresu acerconnect.com.
- 7. 在瀏覽器中輸入 acerconnect.com。
- 7. Írja be a böngészőbe az acerconnect.com címet.
- 7. Typ acerconnect.com in de browser.
- 7. Syötä selaimen acerconnect.com.
- 7. Indtast acerconnect.com i din browser.
- 7. Skriv inn acerconnect.com i nettleseren.
- 7. Skriv in acerconnect.com i webbläsaren.

- 8. Enter Admin Password.
- 8. Geben Sie das Admin-Kennwort ein.
- 8. Entrez le mot de passe Admin.
- 8. Cambiar la contraseña de administrador.
- 8. Immettere la password amministratore.
- 8. Introduza a palavra-passe de administrador.
- 8. Wprowadź hasło administratora.
- 8. Zadejte heslo správce.
- 8. 輸入管理員密碼。
- 8. Adja meg az Admin jelszót.
- 8. Voer Admin-wachtwoord in.
- 8. Syötä järjestelmänvalvojan salasana.
- 8. Indtast administratoradgangskoden.
- 8. Angi adminpassord.
- 8. Ange admin-lösenordet.





## ACER LIMITED WARRANTY AGREEMENT

<b>Warranty Length/Type</b>	<b>1 Year Limited: Parts &amp; Labor, Mail In or Carry In</b>
<b>Hardware Technical Support</b>	<b>1 Year</b>
<b>Software Support</b>	<b>90 days</b>
<b>Service Website</b>	<b><a href="http://www.acersupport.com">http://www.acersupport.com</a></b>
<b>Service Phone Number</b>	<b>866-695-2237 (United States) 866-706-2237 (Canada)</b>

**[Binding Arbitration provisions are not applicable to Quebec consumers]**  
**THIS AGREEMENT CONTAINS A MANDATORY AND BINDING ARBITRATION PROVISION IN WHICH YOU AND ACER AGREE TO RESOLVE ANY DISPUTES BETWEEN YOU AND ACER BY BINDING ARBITRATION. PLEASE SEE SECTION 9 BELOW.**

This Agreement ("Agreement") is between the original purchaser ("You") and Acer America Corporation ("Acer") and applies to Acer branded products ("Products") and services purchased in the U.S. or Canada by You from Acer or any of its subsidiaries or affiliates or an Acer authorized reseller ("Reseller"). This limited warranty is valid only in the U.S. and Canada. This limited warranty extends only to You, the original purchaser, and is not transferable to anyone who subsequently purchases, leases, or otherwise obtains the Product from You. This limited warranty does not cover software or non-Acer branded products (e.g., printers, scanners, etc.).

The term of this Limited Warranty (the "Limited Warranty Period") is identified in the reference table included with this Agreement ("Warranty Reference Table") and shall apply to all Products with the exception of lamps purchased with projectors. If You have purchased a projector, the lamp is warranted for a period of ninety (90) days. If You have purchased a Product that includes a rechargeable battery, Acer warrants that the battery will be free from defects in material and workmanship for the shorter of (a) the period set forth in the Warranty Reference Table or (b) one (1) year from the date of purchase of the Product that uses the battery. As with all batteries, the maximum capacity of the battery included in the Product will decrease with time or use. The battery warranty does not cover changes in battery capacity. Your battery is only warranted from defects in materials or workmanship resulting in failure. Battery life is not warranted and will vary depending on Product configuration and usage including, but not limited to Product model, applications running, power management settings,

- DAMAGES CAUSED BY MISUSE, ABUSE, ACCIDENTS, FIRE, THEFT, DISAPPEARANCE, MISPLACEMENT, FLUCTUATIONS AND POWER SURGES, CONNECTIONS TO IMPROPER VOLTAGE OR INCORRECT ELECTRICAL LINE VOLTAGE, VIRUSES, MALWARE, RECKLESS, WILLFUL, OR INTENTIONAL CONDUCT;
- DAMAGES CAUSED BY SERVICING NOT AUTHORIZED BY ACER;
- DAMAGES CAUSED BY USAGE THAT IS NOT IN ACCORDANCE WITH PRODUCT INSTRUCTIONS OR USER MANUALS, FAILURE TO FOLLOW THE PRODUCT INSTRUCTIONS OR USER MANUALS OR FAILURE TO PERFORM CLEANING OR PREVENTIVE MAINTENANCE;
- DAMAGE CAUSED BY A PRODUCT OR PART THAT HAS BEEN MODIFIED TO ALTER FUNCTIONALITY OR CAPABILITY WITHOUT THE WRITTEN PERMISSION OF ACER;
- DAMAGES CAUSED BY THE COMBINATION OF ACER BRANDED PRODUCTS WITH OTHER NON-ACER BRANDED PRODUCTS, ACCESSORIES, PARTS OR COMPONENTS (INCLUDING SIMS CARDS OR MEMORY CARDS) OR USE OF PRODUCTS, EQUIPMENT, SYSTEMS, UTILITIES, SERVICES, PARTS, SUPPLIES, ACCESSORIES, APPLICATIONS, INSTALLATIONS, REPAIRS, EXTERNAL WIRING OR CONNECTORS NOT SUPPLIED OR AUTHORIZED BY ACER WHICH DAMAGE THIS PRODUCT OR RESULT IN SERVICE PROBLEMS;
- SIGNAL ISSUES, RECEPTION PROBLEMS AND DISTORTION RELATED TO NOISE, ECHO, INTERFERENCE OR OTHER SIGNAL TRANSMISSION AND DELIVERY PROBLEMS;
- RESULTS OF NORMAL USAGE, SUCH AS GRADUAL IMAGE DEGRADATION, UNEVEN SCREEN AGING, BURNED-IN IMAGES AND PIXEL FAILURE WITHIN DESIGNED SPECIFICATIONS OR THAT DO NOT MATERIALLY ALTER THE PRODUCTS FUNCTIONALITY;
- UNINTERRUPTED OR ERROR-FREE OPERATION OF THE PRODUCT;
- SOFTWARE, INCLUDING THE OPERATING SYSTEM AND SOFTWARE ADDED TO YOUR PRODUCT THROUGH OUR FACTORY-INTEGRATION SYSTEM, THIRD-PARTY SOFTWARE, OR THE RELOADING OF SOFTWARE;
- ANY EQUIPMENT OR COMPONENTS THAT WERE NOT INCLUDED IN YOUR PRODUCT AS ORIGINALLY SOLD TO YOU;
- LOSS OF DATA;
- NORMAL WEAR AND TEAR;
- MINOR IMPERFECTIONS THAT MEET DESIGN SPECIFICATIONS;
- COSMETIC DAMAGE OR EXTERIOR FINISH THAT DOES NOT AFFECT FUNCTIONALITY INCLUDING BUT NOT LIMITED TO SCRATCHED OR CRACKED DISPLAYS;
- PRODUCTS WHERE THE ACER SERIAL NUMBER IS MISSING, ALTERED OR DEFACED;
- EXTERNAL SPEAKERS, KEYBOARDS AND MICE;

and Product features. The Limited Warranty Period commences on the date of purchase by You. Your original purchase invoice (sales receipt) showing the date of purchase of the Product is your proof of the date of purchase.

**1. Product Limited Warranty.** Acer warrants that its Products will be free from defects in materials and workmanship for the Limited Warranty Period. During the Limited Warranty Period, Acer will, at its option: (i) provide replacement parts necessary to repair the Product; (ii) repair the Product or replace it with a comparable product; or (iii) refund the amount You paid for the Product, LESS DEPRECIATION, upon its return. Replacement parts and Products will be new or serviceably used, comparable in function and performance to the original part or Product and warranted for the remainder of the original warranty period or, if longer, 90 days after they are shipped to You.

**2. Hardware Technical Support.** During the Limited Warranty Period, Acer will provide Product technical support. After the expiration of the Limited Warranty Period, hardware technical support is available for a fee. The fee will be charged to your credit card when You call technical support. Please note that when contacting Acer via telephone, long distance and other charges may apply, depending upon your calling area. The scope of technical support consists of helping You diagnose and resolve problems with defects in Products covered by this Agreement, and reinstalling the factory-installed operating system and software to restore it to the original factory configuration. Acer may provide technical support via on-line, telephone and other methods. Acer may change the means through which it provides technical support at any time without notice to You.

**3. Software Support for Operating System Software.** Acer is not the manufacturer of the software or operating system and does not guarantee that software or operating systems will be free from errors, either in isolation or in combination with hardware. For your Product, Acer will assist the original purchaser with (i) installation of any operating system software purchased from Acer; (ii) configuration of the operating system software; (iii) setup of the operating system software; and (iv) troubleshooting issues associated with the operating system software.

#### 4. Limitations and Exclusions.

**THIS LIMITED WARRANTY DOES NOT COVER AND ACER IS NOT RESPONSIBLE FOR:**

- DELIVERY OR INSTALLATION, OR LABOR CHARGES FOR INSTALLATION OR SETUP OF THE PRODUCT, ADJUSTMENT OF CUSTOMER CONTROLS ON THE PRODUCT, AND INSTALLATION OR REPAIR OF ANTENNA SYSTEMS OUTSIDE OF THE PRODUCT;

- WIRELESS DATA SERVICES PROVIDED BY THIRD PARTY PROVIDERS;
- DAMAGE CAUSED AS A RESULT OF IMPROPER TRANSPORTATION OR PACKING/ PACKAGING WHEN RETURNING THE PRODUCT TO ACER OR AN ACER AUTHORIZED SERVICE PROVIDER;
- A PRODUCT THAT REQUIRES MODIFICATION OR ADAPTATION TO ENABLE IT TO OPERATE IN ANY COUNTRY OTHER THAN THE COUNTRY FOR WHICH IT WAS DESIGNED, MANUFACTURED, APPROVED AND/OR AUTHORIZED, OR REPAIR OF PRODUCTS DAMAGED BY THESE MODIFICATIONS.

ANY WARRANTY APPLICABLE TO SOFTWARE, INCLUDING OPERATING SYSTEMS, OR NON-ACER BRANDED PRODUCTS IS PROVIDED BY THE ORIGINAL MANUFACTURER.

**5. Registration.** Registration of your Product helps Acer better serve You. Acer encourages You to register your Product within thirty (30) days of the original purchase in order to receive prompt service and support coverage should You need it. To register go to <http://www.acersupport.com> and choose "Register Your System." In accordance with applicable law, Acer may require that You furnish proof of purchase details and/or comply with registration requirements before receiving warranty service.

**6. Instructions for Obtaining Warranty Service.** For specific instructions on how to obtain warranty service for your Product, please refer to the Warranty Reference Table contained in this booklet and go to <http://www.acersupport.com>

To obtain warranty service:

- You must assist Acer in diagnosing issues with your Product and follow Acer's warranty processes.
- You must obtain warranty service from Acer or an Acer Authorized Service Center. Acer will not reimburse You for service performed by others.
- If Acer decides that You need a replacement part(s) or replacement Product, Acer may require a credit card authorization or other security to receive replacement part(s) or Product and may require You to pay the cost of shipping the replacement part(s) or Product to You and the cost of returning the defective part or Product to Acer. Acer will then authorize shipment of the required part(s) or Product to You.
- You may be required to deliver and retrieve your Product to and from Acer or an Acer Authorized Service Center at your expense. When sending a Product to Acer or the Acer Authorized Service Center, You must deliver the Product, freight prepaid, in either its original packaging or packaging affording an equal degree of protection. You are responsible for properly packaging your Product, paying all shipping costs, insurance costs, loss or damage to the Product during shipping, and any other taxes,

fees, duties or charges associated with transporting the Product to Acer or an Acer Authorized Service Center. **YOU ARE RESPONSIBLE FOR ANY DAMAGE TO YOUR ACER PRODUCT DURING SHIPMENT TO ACER OR AN ACER AUTHORIZED SERVICE CENTER.**

- Before providing your Product to Acer or an Acer Authorized Service Center for service, remove any confidential, proprietary or personal information, and removable media, such as disks, CDs, or PC Cards.
- If Acer asks You to return defective parts or Products, You must do so within 15 days after You receive the replacement parts or Products. If You fail to return the replacement part(s) or Product as instructed, Acer will charge the credit card for the authorized amount. All exchanged parts and Products replaced under this Agreement will become the property of Acer.

**IT IS YOUR RESPONSIBILITY TO BACK UP THE CONTENTS OF YOUR HARD DRIVE BEFORE SERVICES ARE PERFORMED AND REMOVE ANY DATA FROM PARTS OR PRODUCTS RETURNED TO ACER OR AN ACER AUTHORIZED SERVICE CENTER, INCLUDING ANY DATA YOU HAVE STORED OR SOFTWARE YOU HAVE INSTALLED ON THE HARD DRIVE. IT IS POSSIBLE THAT THE CONTENTS OF YOUR HARD DRIVE WILL BE LOST OR REFORMATTED IN THE COURSE OF SERVICE AND ACER WILL NOT BE RESPONSIBLE FOR ANY DAMAGE TO OR LOSS OF ANY PROGRAMS, DATA, OR OTHER INFORMATION STORED ON ANY MEDIA OR ANY PART OF ANY PRODUCT SERVICED. IF DURING THE REPAIR OF THE PRODUCT THE CONTENTS OF THE HARD DRIVE ARE ALTERED, DELETED, OR IN ANY WAY MODIFIED, ACER IS NOT RESPONSIBLE FOR ANY LOSS OF YOUR DATA WHATSOEVER. YOUR PRODUCT WILL BE RETURNED TO YOU CONFIGURED TO THE ORIGINAL FACTORY CONFIGURATION (SUBJECT TO AVAILABILITY OF SOFTWARE).**

**7. Implied Warranties. EXCEPT TO THE EXTENT PROHIBITED BY APPLICABLE LAW, ANY IMPLIED WARRANTY OF MERCHANTABILITY, FITNESS FOR A PARTICULAR PURPOSE AND NON-INFRINGEMENT IS LIMITED IN DURATION TO THE DURATION OF THIS WARRANTY.**

Commercial Purchasers: Acer extends the above limited warranty to purchasers of Products for industrial, commercial and business use upon the same terms and conditions and exclusions applicable to consumer purchasers. **HOWEVER, WITH RESPECT TO COMMERCIAL PURCHASERS, ALL IMPLIED WARRANTIES, INCLUDING THE IMPLIED WARRANTIES OF MERCHANTABILITY, FITNESS FOR A PARTICULAR PURPOSE AND NON-INFRINGEMENT, ARE EXCLUDED AND DISCLAIMED.**

decisions are as enforceable as any court order and are subject to VERY LIMITED REVIEW BY A COURT. **YOU ACKNOWLEDGE THAT, BY WAY OF THIS AGREEMENT, YOU AND ACER WAIVE ALL RIGHTS TO A JURY TRIAL.**

The arbitration, or any portion of it, will not be consolidated with any other arbitration and will not be conducted on a class-wide or class-action basis. The arbitration shall be held at any reasonable location near your residence by submission of documents, by telephone, online or in person, whichever method of presentation You choose.

Under the AAA Supplementary Procedures for Consumer-Related Dispute and Consumer Due Process Protocol, You retain the right to seek relief in a small claims court for Disputes within the scope of the small claims court's jurisdiction. The small claims action, or any portion of it, will not be consolidated with any other action and will not be conducted on a class-wide or class-action basis.

If You prevail in the arbitration of any Dispute with Acer, Acer will reimburse You for any fees You paid to AAA in connection with the arbitration. **ANY DECISION RENDERED IN SUCH ARBITRATION PROCEEDINGS WILL BE FINAL AND BINDING ON THE PARTIES, AND JUDGMENT MAY BE ENTERED THEREON IN ANY COURT OF COMPETENT JURISDICTION.**

**YOU UNDERSTAND THAT, IN THE ABSENCE OF THIS PROVISION, YOU WOULD HAVE HAD A RIGHT TO LITIGATE DISPUTES THROUGH A COURT, INCLUDING THE RIGHT, IF ANY, AND SUBJECT TO THE RULES OF YOUR JURISDICTION, TO LITIGATE CLAIMS ON A CLASS-WIDE OR CLASS-ACTION BASIS, AND THAT YOU HAVE EXPRESSLY AND KNOWINGLY WAIVED THOSE RIGHTS AND AGREED TO RESOLVE ANY DISPUTES IN ACCORDANCE WITH THE PROVISIONS OF THIS SECTION.** If this specific provision is found to be unenforceable, then the entirety of this arbitration provision shall be null and void.

This provision shall be governed by the Federal Arbitration Act, 9 U.S.C. Section 1, et seq. For the purposes of this Agreement, the term "Dispute" means any dispute, controversy, or claim arising out of or relating to (i) this Agreement, its interpretation, or the breach, termination, applicability or validity thereof; (ii) the related order for, purchase, delivery, receipt or use of any product or service from Acer; or (iii) any other dispute arising out of or relating to the relationship between You and Acer, its parents, subsidiaries, affiliates, directors, officers, employees, beneficiaries, agents, assigns, component suppliers (both hardware and software), and/ or any third party who provides products or services purchased from or distributed by Acer. The term "You"

**8. Limitation of Liability. ACER SHALL NOT BE LIABLE FOR ANY INCIDENTAL OR CONSEQUENTIAL DAMAGES FOR BREACH OF ANY EXPRESS OR IMPLIED WARRANTY. ACER'S MAXIMUM LIABILITY IS LIMITED TO THE PURCHASE PRICE YOU PAID FOR PRODUCTS OR SERVICES PLUS INTEREST ALLOWED BY LAW. ACER IS NOT LIABLE TO YOU FOR EVENTS BEYOND ACER'S CONTROL, SUCH AS ACTS OF GOD, VIRUSES, PROPERTY DAMAGE, LOSS OF USE, INTERRUPTION OF BUSINESS, LOST PROFITS, LOST DATA OR OTHER CONSEQUENTIAL, PUNITIVE OR SPECIAL DAMAGES, HOWSOEVER CAUSED, WHETHER FOR BREACH OF WARRANTY, CONTRACT, TORT (INCLUDING NEGLIGENCE), STRICT LIABILITY OR OTHERWISE.**

Some states or jurisdictions do not allow the exclusion or limitation of incidental or consequential damages, or allow limitations on how long an implied warranty lasts, so the above limitations may not apply to You. This Agreement gives You specific legal rights and You may have other rights which vary from state to state, jurisdiction to jurisdiction or province to province.

**9. Binding Arbitration. [BINDING ARBITRATION PROVISIONS ARE NOT APPLICABLE TO QUEBEC CONSUMERS] THIS AGREEMENT PROVIDES THAT ALL DISPUTES BETWEEN YOU AND ACER WILL BE RESOLVED BY MANDATORY AND BINDING ARBITRATION TO THE FULLEST EXTENT PROVIDED BY LAW. YOU AND ACER THEREFORE GIVE UP YOUR RIGHT TO GO TO COURT TO ASSERT OR DEFEND YOUR RIGHTS UNDER THIS AGREEMENT (EXCEPT FOR MATTERS THAT MAY BE TAKEN TO SMALL CLAIMS COURT AS FURTHER SET FORTH BELOW IN THIS SECTION 9).**

To the fullest extent provided by law, and except as otherwise provided below, You and Acer agree that any Dispute (as further defined below in this Section 9) between You and Acer will be resolved exclusively and finally by binding arbitration administered by the American Arbitration Association (AAA) and conducted in accordance with the AAA's Supplementary Procedures for Consumer-Related Disputes of the Commercial Arbitration Rules and the Consumer Due Process Protocol. **YOUR RIGHTS WILL THEREFORE BE DETERMINED BY A NEUTRAL ARBITRATOR AND NOT A JUDGE OR JURY.** You and Acer will agree on another arbitration forum, as well as procedures under which the arbitration will be conducted, if AAA ceases operations.

The arbitration will be conducted before a single arbitrator, and will be limited solely to the Dispute between You and Acer. Arbitration is a process whereby a dispute is submitted to an arbitrator, for a final and binding determination, known as the award. The arbitrator is an individual, similar to a judge, who reviews and weighs evidence provided by both parties, and renders an award enforceable in court. Arbitrator

means the original purchaser and those in privity with the original purchaser, such as family members or beneficiaries.

Further information may be obtained from the AAA on line at [www.adr.org](http://www.adr.org), by calling 800-778-7879, or writing to American Arbitration Association, 1633 Broadway, 10th Floor, New York, NY, 10019.

**10. Out of Warranty Repairs.** Any services provided to You by Acer that are not within the scope of the Product Limited Warranty or that are not covered by an extended service plan are governed by this Agreement and are otherwise subject to the terms of the Acer out-of-warranty service procedures and any applicable service order. For a period of ninety (90) days after services are performed, Acer warrants that services provided by it were performed in a professional and workmanlike manner. If your problem recurs within the 90-day service warranty period, Acer will, at its option, (i) re-perform the services, (ii) replace the Product pursuant to the terms of this Agreement, (iii) permit You to return the Product and issue a refund pursuant to the terms of this Agreement, (iv) refund the amount You paid for the services. If You purchased an extended service plan from Acer or from a third party, please refer to the extended service plan for its coverage, duration and terms of service.

**11. General.** Acer and its subsidiaries and affiliates are intended beneficiaries of this Agreement. Any inconsistency between this Agreement and any other agreement included with or relating to products or services purchased from Acer, other than an extended service plan, shall be governed by this Agreement. This Agreement may not be modified, altered or amended without the written agreement of Acer which specifically states that the writing is intended to modify, alter or amend this Agreement. Any additional or altered terms shall be null and void, unless expressly agreed to in writing by Acer. If any term of this Agreement is illegal or unenforceable, the legality and enforceability of the remaining provisions shall not be affected or impaired. **[The exclusivity of the following provision is not applicable to Quebec consumers] THIS AGREEMENT AND ANY SALES THEREUNDER SHALL BE GOVERNED BY THE LAWS OF THE STATE OF TEXAS, WITHOUT REGARD TO CONFLICTS OF LAWS RULES.**

**12. Privacy Notice.** You can review Acer's Privacy Policy on our web site, located at <http://www.acerpanam.com>. Acer will maintain and use your customer information in accordance with its Privacy Policy.

**13. For Residents of Canada:** This Agreement is subject to the applicable provisions of Canadian consumer protection laws that cannot be derogated from by private agreement or which may prohibit the application of any provision or stipulation herein.





## ACER WARRANTY CERTIFICATE FOR LATIN AMERICA

<b>Warranty Length/Type</b>	<b>1 Year Limited: Carry-In</b>
<b>Hardware Technical Support</b>	<b>1 Year</b>
<b>Software Support</b>	<b>90 Days</b>
<b>Service Website</b>	<b><a href="http://www.acersupport.com">http://www.acersupport.com</a></b>

The Acer brand product purchased from Acer or an Authorized Distributor, is covered under a one (1) year Limited Warranty granted by Acer through its National Service Centers and Authorized Service Centers in each country, against any defects in manufacture, functionality, materials or workmanship under normal use during the warranty period.

### Terms and Conditions of the Acer Warranty

The Warranty of your Acer product consists of one (1) year for labor service and one (1) year for replacement or repair of parts with the original configuration of the product (Hardware), provided by the Service Center, commencing on the date of purchase. During the warranty period, Acer will repair or replace defective parts with original parts at no charge to the customer. All parts replaced under this warranty will become the property of Acer.

### General Information

#### 1. Acer Support and Service

Simply call the National Service Center or visit us at [www.acersupport.com](http://www.acersupport.com) and our technicians will help diagnose, and if possible, resolve the problem related to your product. When contacting Acer via telephone, long distance and other changes may apply, depending on your calling area and your service provider. If resolving the problem is not possible, you will have to contact the Service Center for repair.

#### 2. Warranty in the Service Center

During the warranty period, the customer must deliver the Acer product to the Acer National Service Center or to any Acer Authorized Service Center to carry out the repair.

#### 3. Hardware Warranty

The limited warranty period will begin at the time the product is purchased by the original Purchaser, without regard to any sale or transfer the product by the original Purchase to a third party at a later time. This warranty cannot be extended and cannot be re-registered at the time of sale or transfer previously referenced, in accordance with the requirements of section 1 of the Conditions section of this Certificate.

#### 8. Extended Warranty

The customer may extend a product's factory warranty by purchasing extended warranty policies during the Warranty Period through the Acer National Service Center or Acer Authorized Service Centers. Excluded from warranty extensions are components such as the mouse, keyboard and speakers for desktop computers, and batteries for laptops.

#### 9. National Service Centers and Authorized Service Centers

Information on your local Acer National Service Centers and the list of Acer Authorized Service Centers may be found at the Acer website [www.acersupport.com](http://www.acersupport.com). These establishments are highly qualified to carry out the repair of Acer products and original parts can be acquired through them.

### Conditions

#### 1. To validate this warranty:

The customer must present this certificate and the original purchase receipt, along with the defective product and the Recovery disk (CD) at the Acer National Service Center or any of the Acer Authorized Service Centers in that customer's country.

#### 2. This Limited Warranty covers:

The Acer brand product from the time of purchase and will only be valid in the country in which it was purchased. In the case of Notebooks, it also covers the original battery supplied by the manufacturer for one (1) year.

3. In the event that, at Acer's discretion, it may not be possible to repair the product, Acer is committed within the warranty period to replace the product for another Acer product of equal characteristics, whether new or refurbished, at no cost to the customer.

4. With the exception of major or unforeseen circumstances, the repair time in any event will not be more than 30 calendar days from the date of receipt of the product at the Acer National Service Center or any of the Acer Authorized Service Centers.

The terms of this limited warranty are valid at the Acer National Service Center or at any of the Acer Authorized Service Centers that Acer may have in the country and it extends only to Acer brand products and parts.

#### 4. Software Warranty

The preinstalled original software has a ninety (90) days warranty period from the date of purchase of the Acer product. During this period, the software will be reinstalled to its original factory.

In the event of a defective hard drive for Desktops and Notebooks, the hard drive will be replaced and the software will be reinstalled to its original factory configuration by utilizing the recovery disk (CD) or media provided by the customer.

**It is the customer's responsibility to back up the original software and to provide the recovery disk (CD) when reinstallation of the software is necessary.**

Acer is not responsible, directly or indirectly, for any loss of data under any circumstances.

After the ninety (90) days Software Warranty period, the National Service Center and the ASP will charge for software reinstallation and product reconfiguration services.

#### 5. Peripheral Accessories

Only peripheral accessories manufactured by Acer or that form a part of an Acer unit are covered under this Limited Warranty. Peripheral accessories include only the keyboard and mouse.

#### 6. Warranty for Repaired Parts

All spare parts have a ninety (90) day warranty.

Once a replacement part has been installed in an Acer product, it is covered by the greater corresponding warranty, in other words, the 90 day parts warranty or the remainder of the Limited Warranty period of the product.

If the spare part is installed in a product that is not an Acer brand product or in a unit that is out of warranty, the spare part's warranty will be limited to ninety (90) days.

#### 7. Transfer of Warranty

The Acer Limited Warranty is NOT transferable with the product to anyone who subsequently purchases, leases or acquires the product from the original Purchaser.

### Exclusions

This warranty is not valid in the following cases:

- When the serial number of the product has been damaged, altered or erased.
- When it has not been proven that the product is within the warranty period.
- When the failure is due to misuse, or failure to use the product in accordance with the User's Manual that accompanies the product.
- When there has been a previous attempt to repair outside of the Acer National Service Center or any of the Acer Authorized Service Centers listed on the Acer website <http://www.acersupport.com>
- When the product has received any accidental or intentional physical damage or has been exposed to harmful elements such as water, acid, fire, weather, fluctuations in voltage or any other similar or analogous damage.
- When the failure is due to improper or lack of maintenance.
- When the damage is caused by the combination of Acer branded products with other non-Acer branded products, accessories or parts.
- Any equipment, parts or software that were not included in your product as originally sold to you. In these cases, any applicable warranty is provided by the original manufacturer.
- When the product has been altered.
- Failures due to reconfiguration of software and other applications not included in the original product. Under no circumstance is Acer or any Acer Authorized Service Center responsible for any loss of information or data of the end user due to hardware or software issues.
- When the product has been exposed to a virus.
- Spare parts that present normal wear and tear due to use (e.g. battery, plastics, keyboard, etc.)

The battery life is not guaranteed and depends on the use and configuration, including but not limited to: product model, applications in use, power manager configuration and accessories attached to the computer. The battery is guaranteed

against manufacturing flaws and defects. The battery warranty does not cover the reduction of its capacity of charge and retention.

m. When the product was purchased from an unauthorized Distributor or Reseller.

n. Minor defects in the LCD Display. It is considered that the defect on the display is minor when the number of the defective pixels per million is less than four (4) and when the defective pixels in the display's central area is no more than one (1). It is agreed that the display's central area consists of the rectangular area at the center of the display that is determined by dividing the display into 9 equal rectangles by two vertical lines and two horizontal lines.

### Registration

Registration of your Product helps Acer better serve you. Acer encourages you to register your Product within thirty (30) days of the original purchase in order to receive prompt service and support coverage should you need it. To register go to Acer's service website: <http://www.acersupport.com> and choose "Register Your System".

### Centros de Servicio Autorizados en América Latina (Centros de Serviços Autorizados na América Latina)

Centro Nacional de Servicio Acer México  
CNS México S. A. de C.V.  
Para obtener soporte y servicio llame al  
001-866-350 2237 o ingrese a [www.acer.com](http://www.acer.com)  
Domicilio para efectos fiscales:  
Avenida de los Cien Metros No. 1112  
Gustavo A Madero, CP 07700, Ciudad de México

\*Este no es un Centro de atención a clientes.  
Centro Nacional de Servicio Acer Argentina  
Techcomm SRL  
Av. San Juan 1332, C.A.B.A.  
C.A. de Buenos Aires 1148  
Buenos Aires, Argentina  
Tel: 0800-444-1318  
[www.techcomm.com.ar](http://www.techcomm.com.ar)

Centro Nacional de Servicio Acer Perú  
High Service  
Av. Alfredo Benavides Num. 2969  
Urb. Alexander Von Humbolt  
Miraflores - Lima - Perú  
Tel: 0800-54495  
[www.acer.com](http://www.acer.com)  
[www.highservice.com.pe](http://www.highservice.com.pe)

Centro Nacional de Servicio Acer Venezuela  
TecnoAsist C.A.  
Centro Comercial Caurimare  
Mezantina, Local 33  
Urb. Caurimare, El Cafetal  
Caracas - Venezuela  
Tels: (58-212) 987-7223 / 985-6990  
[www.acer.com](http://www.acer.com)

Centro Nacional de Servicio Acer Colombia  
Punto de Servicios  
CRA 49 No.93-12  
La Castellana.  
Bogotá - Colombia  
Tel: 01-800-915-7126  
[www.acer.com](http://www.acer.com)  
[www.puntodeservicios.com](http://www.puntodeservicios.com)

Centro Nacional de Servicio Acer Chile  
NetNow Tecnología y Computación S.A  
Av. Las Torres 1278 Huechuraba  
Santiago - Chile  
Tel: (600) 460 4000  
[www.acer.com](http://www.acer.com)  
[www.netnow.cl](http://www.netnow.cl)

Centro Nacional de Servicio Acer Ecuador  
ABC Laptops  
Edif. Plaza Colón 2, Ofic. 26 Mezanine  
9 de Octubre 16-01 y Av. Cristóbal Colón  
Quito - Ecuador  
Tel: 593 (02) 2909099  
[www.acer.com](http://www.acer.com)  
[www.abclaptops.com](http://www.abclaptops.com)

Centro Nacional de Servicio Acer Puerto Rico  
M.A.K.E. Technologies  
Calle Julio Pérez Trizarry Num.23  
Hormigueros 00660  
Tels: (787) 849-0551 / 1-866-569-2237  
[www.acer.com](http://www.acer.com)  
[Acer\\_Services@mtlogisticspr.com](mailto:Acer_Services@mtlogisticspr.com)

Centro Nacional de Servicio Acer Costa Rica  
Sauter Infomax  
Calle 11, entre Ave. Central y Segunda  
Edif. Bellavista, 2° Piso  
San José - Costa Rica. 13243  
Tel: (506) 258-5280  
[www.acer.com](http://www.acer.com)  
[www.sauter-infomax.co.cr](http://www.sauter-infomax.co.cr)  
Centro Nacional de Servicio Acer Uruguay  
Lekemil S.A.  
Maldonado 1035 PR 11100, Esq. Rio Negro  
Montevideo - Uruguay  
Tel: (598) 2903-0166  
[www.acer.com](http://www.acer.com)  
[www.cns.com.uy](http://www.cns.com.uy)

Centro Nacional de Servicio Acer Bolivia  
Artes Electrónicas S.R.L.  
Calle Mercado No. 1357  
La Paz - Bolivia  
Tels: (591) 2 220-0701 / 800-100620  
[www.acer.com](http://www.acer.com)  
[www.artes-electronicas.com](http://www.artes-electronicas.com)

Acer National Service Center - Barbados  
Online Consultancies LTD  
5A 5B Clermont.  
St. Thomas - Barbados  
Tel: (246) 438-6666  
[olc@caribsurf.com](mailto:olc@caribsurf.com)

Centro Nacional de Servicio Acer Nicaragua  
STG / Soporte Técnico Global Nicaragua S.A.  
Km 4.5 Carretera a Masaya  
Frente a edificio Pellas  
Managua, Nicaragua  
Tels: (505) 2277-5889  
[www.acer.com](http://www.acer.com)

Centro Nacional de Servicio Acer Guatemala  
Tech Hospital  
Diagonal 6 12-42  
Edificio Design Center Zona 10 2do Nivel Oficina  
216, Guatemala City.  
Tel: (502) 2508-7301  
[www.acer.com](http://www.acer.com)  
[www.tech-hospital.com](http://www.tech-hospital.com)  
Centro Nacional de Servicio Acer Paraguay  
Diesa S.A.  
Avenida Eusebio Ayala Km 4.5  
Asunción - Paraguay  
Tel: (595-2) 1610-303  
[www.acer.com](http://www.acer.com)  
[www.diesa.com.py](http://www.diesa.com.py)

Centro Nacional de Servicio Acer Panamá  
ECCSA  
Parque Lefevre, Av. Santa Elena  
Edificio Forro Auto, Local #1  
Ciudad de Panamá  
Tel: 001-800-507-3345 / (507) 222-2292  
[www.acer.com](http://www.acer.com)

Centro Nacional de Servicio Acer El Salvador  
Profesionales en Computación SA de CV  
Calle y Colonia Roma Num.189  
San Salvador - El Salvador.  
Tel: (503) 2298-6499  
[www.acer.com](http://www.acer.com)  
[www.profcomp.com](http://www.profcomp.com)

Centro Nacional de Servicio Acer República Dominicana  
Techcomm Wireless  
Avenida Romulo Betancur Num.1310  
Bella Vista  
República Dominicana - Santo Domingo  
Tel: (809) 535-3178 / 535-5374  
[www.acer.com](http://www.acer.com)  
[www.techcommwireless.com](http://www.techcommwireless.com)

Centro Nacional de Servicio Acer Honduras  
Centro Autorizado de Servicios S.de R.L.  
Blvd. Sta. Cristina, Edificio HCT.  
Colonia Miraflores  
Tegucigalpa, Honduras  
Tel: (504) 230-7211  
[www.acer.com](http://www.acer.com)  
Acer National Service Center - Jamaica  
Unicorp Solutions Limited  
Unit 3 & 4  
3 Bradley Avenue  
Kingston 10 Jamaica  
Tel: (876) 631-7591 / 631-7542  
[www.acer.com](http://www.acer.com)  
[services@unicorpsolutionsjm.com](mailto:services@unicorpsolutionsjm.com)

La lista de Centros de Servicio Autorizados puede variar sin previo aviso. Verifique la lista actualizada en:

The list of Authorized Service Centers can be changed without previous notification.

Verify the updated list at:

A lista dos Centros de Serviços Autorizados poderá ser mudada sem aviso prévio.

Verifique a lista atualizada em:

[www.acersupport.com](http://www.acersupport.com)



# acer Warranty Card

<b>Product Name:</b>	<b>Model No. :</b>	<b>Purchased Date:</b>
		(Y) (M) (D)
<b>S/N:</b>		
<b>Name:</b>	<b>TEL:</b>	
<b>Address:</b>		
<b>Email:</b>		

**Shop Seal of Distributor**  
(If the information is incomplete or the shop seal is not stamped, it will be invalid)

### To ensure your rights:

- You can enjoy your warranty services during the designed period with your warranty card.
- Please read the instructions on the back carefully, and keep this warranty card properly. It will not be reissued if lost.

## Acer Philippines Warranty Instructions

### 1. Description of Warranty Period:

- This warranty card is only applicable to the after-sales service of products sold by our company. The products that are not authorized by our company are not covered by the warranty card service.
- Acer Connect / Predator Connect are provided with a one-year free warranty service with this warranty from the date of purchase. Subject to the date of sale on the invoice or warranty.
- After the product has exceeded the one-year free warranty period provided by the company, if there is a need for after-sales service, the company will charge related expenses at its discretion, including logistics, outing, wages and replacement parts.

2. The information in each field of this warranty must be filled in and stamped with the distributor's seal to be valid. If the purchase date and S/N number are altered, ambiguous, or the information is incorrectly filled, this warranty is deemed invalid.

3. If you have any questions about after-sales service, please contact toll free no (02) 7 720-0090 or email to acerstore.ph@acer.com . If device need to be repaired, please send them to the nearest service station authorized by our company.

### 4. Under the following conditions, this product will not be able to provide free services:

- The product has exceeded the warranty period provided by the company.
- Damage caused by sulfur and coastal environment.
- Damage caused by inconsistent voltage specifications.
- For improper use, modification or disassembly without following the operating instructions or machine specifications, our company does not warranty and assumes no legal responsibility.
- Damage or malfunction caused by natural disasters, electric shocks, insect (rat) damage, pets, etc.
- Damage due to exposure to sunlight, high temperature environment or various humid environments.
- Failure caused by the use of non-original parts, consumables, other products, equipment and accessories.
- Damage caused by falling due to the height difference of the ground environment, and scratches or damage to the appearance caused by collision during operation.
- The product is damaged by inputting/inhaling hard or sharp objects, such as glass, nails, screws, coins, etc.

- Appearance, accessories, etc.
- Products not sold by our company.
- Those who cannot show the warranty card/invoice/proof of purchase.

5. This warranty is only limited to the machine itself. If there are additional services such as delivery or installation of accessories, etc., it will be rejected or additional material service fees will be charged as the case may be.

6. The parts are still usable, but if the customer requests a new one, the parts fee will be charged according to the price list of our company.

7. The company can use new or factory reprocessed parts for product maintenance.

8. Please keep this warranty card properly and it will not be reissued.

9. The above listed items and important items in the product manual, if there is any change or supplementary description, will be subject to the latest announcement of the company website (www.acer.com).

## Acer Singapore Warranty Instructions

### 1. Description of Warranty Period:

- This warranty is only applicable to the after-sales service of products sold by our company. The products that are not authorized by our company are not covered by the warranty card service.
- Acer Connect / Predator Connect are provided with a one-year warranty service with this warranty from the date of purchase on the invoice or warranty.
- After the product has exceeded the one-year free warranty period provided by the company, if there is a need for after-sales service, the company will charge related expenses at its discretion, including logistics, outing, wages and replacement parts.

2. If you have any questions about after-sales service, please contact toll free no 1800-895-6299 or email to acer@acer.com.sg@acer.com. If device need to be repaired, please send them to Acer service center.

### 3. Under the following conditions, this product will not be able to provide free services:

- The product has exceeded the warranty period provided by the company.
- Damage caused by sulfur and coastal environment.
- Damage caused by inconsistent voltage specifications.
- For improper use, modification or disassembly without following the operating instructions or machine specifications, our company does not warranty and assumes no legal responsibility.
- Damage or malfunction caused by natural disasters, electric shocks, insect (rat) damage, pets, etc.
- Damage due to exposure to sunlight, high temperature environment or various humid environments.
- Failure caused by the use of non-original parts, consumables, other products, equipment and accessories.

- Damage caused by falling due to the height difference of the ground environment, and scratches or damage to the appearance caused by collision during operation.
- The product is damaged by inputting/inhaling hard or sharp objects, such as glass, nails, screws, coins, etc.
- Appearance, accessories, etc.
- Products not sold by our company.
- Those who cannot show the invoice or proof of purchase.

4. This warranty is only limited to the machine itself. If there are additional services such as delivery or installation of accessories, etc., it will be rejected or additional material service fees will be charged as the case may be.

5. If the parts are still usable, and customer requests a new one, the parts fee will be charged according to the price list of our company.

6. The company can use new or factory reprocessed parts for product maintenance.

7. The above listed items and important items in the product manual, if there is any change or supplementary description, will be subject to the latest announcement of the company website (www.acer.com).

## Acer ประเทศไทย คำแนะนำการรับประกัน

### 1. คำอธิบายเกี่ยวกับระยะเวลาการรับประกัน:

- การรับประกันนี้มีผลกับบริการหลังการขายของผลิตภัณฑ์ ที่จำหน่ายโดยบริษัทเท่านั้น บริการมีตรรับประกันไม่ได้คุ้มครองผลิตภัณฑ์ที่ไม่ได้ระบุขนาดโดยบริษัทของเรา
- Acer Connect / Predator Connect มีบริการรับประกันเป็นระยะเวลาหนึ่งปีพร้อมบัตรรับประกันนี้ นับจากวันที่ซื้อที่ระบบในแง่หนึ่งหรือบัตรรับประกัน
- เมื่อผลิตภัณฑ์พ้นกำหนดระยะเวลาการรับประกันฟรีภายใต้การรับประกันของบริษัทแล้ว หากเจ้าของผลิตภัณฑ์จำเป็นต้องรับบริการหลังการขาย บริษัทจะเรียกเก็บค่าใช้จ่ายที่เกี่ยวข้อง โดยอยู่ภายใต้ดุลยพินิจของบริษัทแต่เพียงผู้เดียว โดยได้แก่ค่าใช้จ่ายเกี่ยวกับकरणส่ง ค่าแรง และค่าอะไหล่

2. ถ้าคุณมีคำถามใด ๆ เกี่ยวกับบริการหลังการขาย โปรดติดต่อผ่านหมายเลขโทรฟรีที่ 0-2153-9655 หรือส่งอีเมลไปที่ ath.dealersupport@acer.com ถ้าจำเป็นต้องซ่อมแซมอุปกรณ์ โปรดส่งไปที่ศูนย์บริการของ Acer

### 3. ภายใต้เงื่อนไขเหล่านี้ ผลิตภัณฑ์จะไม่สามารถ ขอรับบริการฟรีได้:

- ผลิตภัณฑ์ที่เกินระยะเวลาประกันที่กำหนดไว้ของบริษัท
- ความเสียหายอื่นที่เกิดจากสภาพแวดล้อมที่มีซัลเฟอร์และสภาพที่มีความชื้นใกล้ทะเล
- ความเสียหายอื่นที่เกิดจากการใช้แรงดันไฟฟ้าที่ไม่เป็นไปตามขั้วขั้วเฉพาะ
- สำหรับการใช้งานที่ไม่เหมาะสม การดัดแปลงแก้ไข หรือการถอดประกอบที่ไม่เป็นไปตามคำแนะนำการใช้งานหรือข้อมูลจำเพาะของอุปกรณ์ การรับประกันจะถือเป็นโมฆะ และบริษัทของเราจะไม่ความรับผิดชอบ
- ความเสียหายหรือการทำงานที่ไม่ถูกต้องของผลิตภัณฑ์ที่เกิดจากภัยพิบัติตามธรรมชาติ ไฟฟ้าช็อต ความเสียหายจากแสง (พ่น) สีหรือเสียง ฯลฯ
- ความเสียหายเนื่องจากอุปกรณ์อิเล็กทรอนิกส์สภาพแวดล้อมที่รับแสงแดดโดยตรง ได้รับอุณหภูมิสูง หรือสภาพแวดล้อมที่มีความชื้นที่มากเกินไป
- อุปกรณ์ไม่ทำงานอื่นเนื่องมาจากการใช้งานส่วน วัสดุใช้สิ้นเปลือง ผลิตภัณฑ์ เครื่องมือ และอุปกรณ์ต่อพ่วงอื่นๆ ที่ไม่ใช่ของแท้

- ความเสียหายอื่นที่เกิดจากผลิตภัณฑ์ล้มคว่ำอันเกิดจากความสูงที่ต่างระดับของพื้นที่ติดตั้ง และรอยขีดหรือความเสียหายต่อลักษณะภายนอกที่เกิดจากการชนวัสดุอื่นๆ ในระหว่างการใช้งาน
- ผลิตภัณฑ์ได้รับความเสียหายโดยการใส่/การสอดใส่วัตถุแข็งหรือวัสดุคม เช่น แก้ว เล็บมือ สกรู เหยียบ ฯลฯ เข้าไปในตัวผลิตภัณฑ์
- ลักษณะภายนอก อุปกรณ์ต่อพ่วง ฯลฯ
- ผลิตภัณฑ์ที่ไม่ได้จำหน่ายโดยบริษัท
- ผลิตภัณฑ์ที่ไม่สามารถแสดงใบแจ้งหนี้หรือเอกสารพิสูจน์การซื้อ

4. การรับประกันนี้จำกัดเฉพาะที่ตัวเครื่องผลิตภัณฑ์ที่ระบุเท่านั้น หากมีบริการเสริม เช่น การนำส่งหรือการติดตั้งอุปกรณ์ต่อพ่วง ฯลฯ บริการเหล่านี้จะไม่ได้รับการคุ้มครองภายใต้การรับประกัน หรือจะมีการเรียกเก็บค่าใช้จ่ายที่เกี่ยวข้องตามที่เกิดขึ้นจริง

5. ถ้าชิ้นส่วนยังคงใช้งานได้ และลูกค้าขอรับชิ้นส่วนใหม่ ลูกค้าจะถูกเรียกเก็บค่าอะไหล่ตามรายการราคาของบริษัทของเรา

6. บริษัทสามารถให้ชิ้นส่วนใหม่หรือชิ้นส่วนที่ผ่านการแก้ไขใหม่ในโรงงานของเรา สำหรับการบำรุงรักษาผลิตภัณฑ์ได้

7. รายการที่ระบุไว้ข้างต้นรวมถึงรายการที่สำคัญในคู่มือผลิตภัณฑ์ หากมีการเปลี่ยนแปลงใดๆ หรือคำอธิบายเพิ่มเติม จะเป็นไปตามการประกาศล่าสุดในเว็บบไซต์ของบริษัท (www.acer.com)

# Hướng Dẫn Bảo Hành của Acer Việt Nam

## 1. Nội Dung Kỳ Hạn Bảo Hành:

- (1) Bảo hành này chỉ áp dụng cho dịch vụ hậu mãi liên quan đến các sản phẩm được kinh doanh bởi công ty. Các sản phẩm không do công ty chúng tôi ủy quyền kinh doanh sẽ không được hưởng dịch vụ thế bảo hành.
- (2) Acer Connect / Predator Connect được cung cấp dịch vụ bảo hành một năm theo quy chế bảo hành này kể từ ngày mua ghi trên hóa đơn hoặc trên phiếu bảo hành.
- (3) Sau khi sản phẩm hết thời hạn bảo hành miễn phí một năm, nếu khách hàng cần dịch vụ hậu mãi, công ty sẽ tính phí liên quan theo quy định, bao gồm phí logistic, phí xuất kho, thù lao và phí linh kiện thay thế.

2. Nếu có bất kỳ thắc mắc nào về dịch vụ hậu mãi, vui lòng gọi miễn phí tới số 1900 96 96 01 hoặc gửi email tới [acercare.vn@acer.com](mailto:acercare.vn@acer.com). Nếu cần sửa chữa thiết bị, vui lòng gửi tới Trung Tâm Dịch Vụ Acer.

## 3. Trong những điều kiện sau đây, sản phẩm này sẽ không được hưởng các dịch vụ miễn phí:

- (1) Sản phẩm đã hết hạn bảo hành theo quy định của công ty.
- (2) Sản phẩm bị hỏng do tiếp xúc với lưu huỳnh và môi trường bờ biển.
- (3) Sản phẩm bị hỏng do điện áp không ổn định.
- (4) Trong trường hợp tùy ý sử dụng, sửa đổi hoặc tháo lắp không theo hướng dẫn hoặc quy chuẩn kỹ thuật, công ty sẽ không bảo hành và không chịu bất kỳ trách nhiệm pháp lý nào.
- (5) Sản phẩm bị hỏng hoặc lỗi do thiên tai, chập điện, côn trùng (chuột), động vật...
- (6) Sản phẩm bị hỏng do tiếp xúc với ánh sáng mặt trời, nhiệt độ cao hoặc độ ẩm chênh lệch.
- (7) Sản phẩm bị hỏng do không sử dụng linh phụ kiện gốc, hoặc sử dụng các thiết bị và phụ kiện không đúng chủng loại.

- (8) Sản phẩm bị hỏng do rơi vì lý do bề mặt không phẳng, bị xước, hoặc bề mặt bị lỗi do va chạm trong quá trình vận hành.
- (9) Sản phẩm bị hỏng do dính/hút phải vật cứng hoặc sắc nhọn, ví dụ như thủy tinh, móng tay, móng chân, đinh vít, đồng xu...
- (10) Bề ngoài, phụ kiện...
- (11) Sản phẩm không thuộc danh mục kinh doanh của công ty.
- (12) Không xuất trình được hóa đơn hoặc chứng từ mua hàng.

4. Bảo hành này chỉ áp dụng cho hệ máy. Nếu có thêm các dịch vụ ví dụ như giao hàng hoặc lắp phụ kiện..., hoặc là sẽ bị hủy hoặc là sẽ bị tính thêm phí tùy theo từng trường hợp cụ thể.

5. Nếu phụ kiện vẫn sử dụng được nhưng khách hàng yêu cầu đổi mới, công ty sẽ tính phí phụ kiện theo danh mục giá.

6. Công ty có thể sử dụng các phụ kiện mới hoặc phụ kiện đã qua xử lý tại nhà máy khi bảo trì sản phẩm.

7. Các hạng mục được liệt kê trên đây và các phụ kiện quan trọng được nêu trong số hướng dẫn sử dụng sản phẩm, nếu có bất kỳ thay đổi hoặc bổ sung nào, sẽ được xử lý theo quy định mới nhất được công bố trên trang web của công ty ([www.acer.com](http://www.acer.com)).

# Acer India Warranty Instructions

## 1. Description of Warranty Period:

- (1) This warranty card is only applicable to the after-sales service of products sold by our company. The products that are not authorized by our company are not covered by the warranty card service.
- (2) Acer Connect / Predator Connect are provided with a one-year warranty service with this warranty from the date of purchase on the invoice or warranty
- (3) After the product has exceeded the one-year free warranty period provided by the company, if there is a need for after-sales service, the company will charge related expenses at its discretion, including logistics, outing, wages and replacement parts.

2. The information in each field of this warranty must be filled in and stamped with the distributor's seal to be valid. If the purchase date and S/N number are altered, ambiguous, or the information is incorrectly filled, this warranty is deemed invalid.

3. If you have any questions about after-sales service, please contact toll free no 1800-116-677 or email to [ail.easycare@acer.com](mailto:ail.easycare@acer.com). If device need to be repaired, please send them to the nearest service station authorized by our company.

## 4. Under the following conditions, this product will not be able to provide free services:

- (1) The product has exceeded the warranty period provided by the company.
- (2) Damage caused by sulfur and coastal environment.
- (3) Damage caused by inconsistent voltage specifications.
- (4) For improper use, modification or disassembly without following the operating instructions or machine specifications, our company does not warranty and assumes no legal responsibility.
- (5) Damage or malfunction caused by natural disasters, electric shocks, insect (rat) damage, pets, etc.
- (6) Damage due to exposure to sunlight, high temperature environment or various humid environments.
- (7) Failure caused by the use of non-original parts, consumables, other products, equipment and accessories.
- (8) Damage caused by falling due to the height difference of the ground environment, and scratches or damage to the appearance caused by collision during operation.
- (9) The product is damaged by inputting/inhaling hard or sharp objects, such as glass, nails, screws, coins, etc.

- (10) Appearance, accessories, etc.
- (11) Products not sold by our company.
- (12) Those who cannot show the warranty card/invoice/proof of purchase.

5. This warranty is only limited to the machine itself. If there are additional services such as delivery or installation of accessories, etc., it will be rejected or additional material service fees will be charged as the case may be.

6. The parts are still usable, but if the customer requests a new one, the parts fee will be charged according to the price list of our company.

7. The company can use new or factory reprocessed parts for product maintenance.

8. Please keep this warranty card properly and it will not be reissued.

9. The above listed items and important items in the product manual, if there is any change or supplementary description, will be subject to the latest announcement of the company website ([www.acer.com](http://www.acer.com)).

# Acer Malaysia Warranty Instructions

## 1. Description of Warranty Period:

- (1) This warranty card is only applicable to the after-sales service of products sold by Acer. Products that are sold without authorization Acer are not covered by the warranty card service.
- (2) Acer Connect / Predator Connect comes with One-year warranty. Based on date on invoice or warranty card. (based on date as stated on invoice or warranty card).
- (3) In the event there is a need for after-sales service after the expiry of the one-year warranty provided by Acer, Acer shall charge all related expenses which shall include but not limited to costs of logistics, transportation, labour charges and replacement parts.

2. The information in each field of this warranty card must be filled and stamped with the distributor's seal for the warranty to be valid. If the purchase date and S/N number are altered, ambiguous, or the information is incorrectly filled, this warranty is deemed invalid.

3. If you have any questions about after-sales service provided by Acer, please contact toll free no 1800 88 1918 or email to [ama.acercare@acer.com](mailto:ama.acercare@acer.com). Please send any device which need to be repaired them to the nearest service centre authorized by Acer.

## 4. The Product will not be eligible for free after-sales service as per the warranty if:

- (1) The Product has exceeded the warranty period provided by Acer or the warranty card is not presented or is damaged.
- (2) The Product is damaged by sulfur or caused by coastal environments.
- (3) The Product is damaged as a result of connections to irregular voltage source.
- (4) There is improper use, modification or disassembly of the Product without following the operating instructions or machine specifications. In such event, the warranty shall be invalid and Acer shall not assume any legal responsibility.
- (5) The Product is damaged or malfunctioned due to natural disasters (including but not limited to Rood, earthquake, typhoon, lightning strike, infestation by insects or vermin etc), external damages (including but not limited to scratches, hammered, water seepage into products etc).
- (6) The Product is damaged due to exposure to sunlight, high temperature environments or various humid environments.
- (7) There is failure to the Product caused by the use of non-original parts, consumables, equipment and accessories.

- (8) There is damage caused by dropping of the products, or reasonable wear and tear from usage causing scratches or damage to the Product's appearance.
- (9) The Product is damaged by the insertion of hard or sharp objects, such as glass, nails, screws, coins, etc. into the Product, whether on purpose or inadvertently.
- (10) Cosmetic damage to the Product's appearance, accessories or usage wear and tear, etc.
- (11) The Product is not sold by Acer.
- (12) The Customer cannot provide the warranty card/invoice/proof of purchase.

5. This warranty is only limited to the Product itself. If there is additional service required such as delivery or installation of accessories, etc., Acer reserves the right to reject the claim or additional service fees or material costs will be charged as may be applicable.

6. In the event the customer requests for a new replacement parts when the existing parts are still usable, the customer shall pay for the costs of such new replacement parts in accordance to Acer's price list of the same.

7. Acer reserves the right to use either new or factory reprocessed parts for product maintenance or repair.

8. Please keep this warranty card properly as it will not be reissued in the event it is lost or damaged.

9. In the event there is any changes or additional terms to the above listed, Acer shall issue a notice of such changes on its website ([www.acer.com](http://www.acer.com)) and any changes by Acer shall be final.



# LIMITED PRODUCT WARRANTY STATEMENT

**FOR ALL ACER BRANDED CONSUMER AND COMMERCIAL DEVICES SOLD  
IN AUSTRALIA AND NEW ZEALAND**

**THIS WARRANTY STATEMENT IS NOT APPLICABLE TO ACER BRANDED SERVERS  
OR OTHER ENTERPRISE STORAGE**

**This limited hardware warranty is in addition to any rights that you may have under the Australian Consumer Law (the ACL) or the New Zealand Consumer Guarantees Act (the CGA).**

Type of Product	Standard Warranty Entitlement
Acer Branded LCD Monitors	3 years return to base.
Aspire, Nitro, Chrome, Concept D and Predator Series PC	1 year return to base.
Veriton Series Commercial PC	1 to 3 year onsite service, depending on the specific model purchased.
Altos Series Commercial Workstation	3 year onsite service*. Onsite warranty uplift option may be available at time of purchase.
Aspire, Nitro, Concept D, Predator, Enduro, Swift, Spin, Chrome Notebooks	1 year return to base.
Acer Travelmate Series Commercial Notebook	1 to 3 year return to base, depending on the specific model purchased. *Onsite warranty uplift option may be available at time of purchase.
Acer Branded Data Projector	2 year return to base. The warranty period for projector lamp is 1000 hours or 6 months, whichever occurs first.
Acer Tablet PC and Smart Handheld Devices	1 year return to base.
Acer Mixed Reality Head-Mounted Display (HMD)	1 year return to base.
Acer Connect / Predator Connect	1 year return to base.

## General Provisions and Exclusions

Acer Computer Australia and New Zealand warrants that the device you have purchased is free from manufacturing defects in materials and workmanship when dispatched from our warehouse. During the warranty period as indicated above, the Acer Authorised Repair Centre will, at no additional charge, replace defective parts with new parts or serviceable parts that are equivalent to new parts in performance. All replaced or exchanged parts, which are taken

out under this warranty, become the sole property of Acer. \*Onsite services are strictly limited to a distance not exceeding 50 km from an Acer authorised service provider. All onsite servicing and repairs will be carried out within standard business hours of between 09:00-17:00 Monday to Friday, excluding public holidays. It remains the users responsibility to ensure they make their device ready and available at the time of the scheduled onsite service, and to provide a clear working area for the onsite service provider to complete their repairs. All requests for after-hours or weekend onsite service will be quoted at current applicable hourly rates to you, and strictly dependant on after-hours or weekend service availability. In the event where an onsite service provider is not available, Acer will make arrangements to have your device repaired at our service centres, using one of our nominated logistics partners. In the event of a return to base warranty repair, it remains the users responsibility to ensure they suitably pack their device to ensure safe transit to our service centre.

Any damages resulting from improper and/or inadequate packing shall not be considered as product faults and may incur a charge for rectification, if repairable. Acer reserves the right to undertake its own inspection/assessment of any Acer-branded device and further reserves the right to complete its inspection or assessment at our nominated service centres as deemed appropriate. Acer reserves the right to deem any device as Beyond Economical Repair (BER). All goods must have a repair authorisation number issued by Acer, prior to being sent into our service centres. The above-listed models are not designed for cryptocurrency mining. Damages to your product arising from cryptocurrency mining or related activities are excluded from your product warranty. This warranty does not extend to any product purchased from other than an Acer Authorised Reseller and product local warranties apply only in the original country from where the goods were supplied and purchased. This warranty does not apply and, at Acer's discretion, becomes void if the product has been physically damaged or rendered defective: (a) as a result of accident, misuse, or abuse, or other circumstances beyond Acer's control; (b) by the use of parts or peripherals not manufactured or supplied by Acer; (c) as a result of normal wear and tear; (d) by use within an improper operating environment; (e) by modification of the product; (f) by the serial number being removed or defaced; (g) as a result of services rendered by anybody other than an Acer authorised repairer; (h) as a result of the product being operated otherwise than in accordance with Acer's instructions or; (i) as a result of liquid/chemical damage, exposure to bodily fluids and/or solids, or damage resulting from vermin, insect or other pest infestation.

Software-related faults resulting from incorrect software installation or usage, viruses or other malicious applications, or other computer program errors shall not be considered as product faults and may incur a charge for rectification, if requested. It remains the users responsibility to keep useable archive backups of all data and to reload all software following any maintenance or repair work (except the operating system). Acer is not responsible for damage to, or loss of, any programs, data, or removable storage media, including any consequential loss or damage. Acer is also not responsible for future upgrades of software products bundled with Acer Products and make no assurances or guarantees that devices will support or be compatible with any software releases or updates, or hardware not configured and provided by Acer Computer. All devices repaired by Acer's service centres will be restored to their original factory configurations. Repairs made by Acer Authorised Personnel will be chargeable at current applicable hourly rates to you if: (a) the technician finds the problem is user related; (b) caused by change in normal settings of the computer, or (c) software issue not covered under our standard warranty. This warranty is given in addition to the other remedies that are conferred to you by the law. As part of Acer's validation and/or verification process, we reserve the right to undertake further assessment of the device, or ask the user to undertake simple and reasonable troubleshooting measures to test their device. We appreciate your cooperation in this matter.

## Pixel Policy

The LCD screen is manufactured using high precision technology. Due to the complex nature of the manufacturing process, the screen may have cosmetic defects that appears as (bright, dark and colour) dots on the screen. This does not impair the performance of the product and is not considered defective in the industry. Acer reserves the right to refuse a warranty claim for repair or replacement of the LCD panel if the number of defective dots falls within the manufacturers specification.



# LIMITED PRODUCT WARRANTY STATEMENT

FOR ALL ACER BRANDED CONSUMER AND COMMERCIAL DEVICES SOLD  
IN AUSTRALIA AND NEW ZEALAND

THIS WARRANTY STATEMENT IS NOT APPLICABLE TO ACER BRANDED SERVERS  
OR OTHER ENTERPRISE STORAGE

This limited hardware warranty is in addition to any rights that you may have under the Australian Consumer Law (the ACL) or the New Zealand Consumer Guarantees Act (the CGA).

All batteries, either removable batteries or those contained within an Acer mobile/portable device, carry a one year limited hardware warranty regardless of the length of the system base warranty. In addition to the one year limited hardware warranty on all batteries, some customers may have purchased a separate warranty uplift for their batteries providing specific warranty coverage for either two or three years in total.

In the instance whereby a separate battery warranty uplift has been purchased, in addition to the system base warranty, Acer will apply a reasonable depletion factor of up to 20% per year for three years, after which the battery will be considered to have served its intended lifespan.

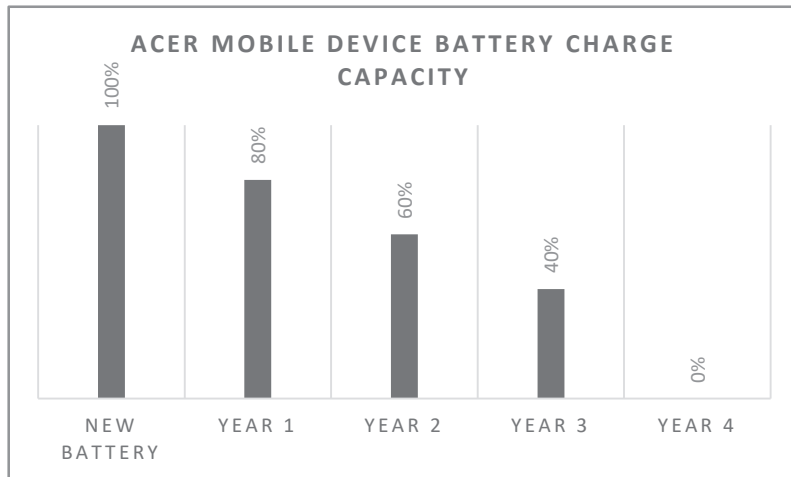

## Making Warranty Claims for your Acer Battery

As part of Acer's validation and/or verification process, we reserve the right to undertake further assessment of the device, or ask the user to undertake simple and reasonable troubleshooting measures to test their battery. We may also ask the user to use our battery testing tool and send us the results.

To ensure your claim is processed in the most efficient manner, please be sure to clearly outline the following details when calling Acer's contact centre or when raising an online service request via Acer's online helpdesk:

- A very clear and detailed description outlining the problem and/or concern with the battery
- The SNID number and serial number of the Acer notebook or tablet device
- Please also advise on whether the Acer Battery Test tool has been run to check the condition of the battery, and inform us of the results.

### Customers in Australia

Technical Support: 1300 365 100  
7:00am to 9:00pm Monday to Friday AEST  
9:00am to 6:00pm Saturday and Sunday AEST

Service and Repair Enquiries: 1300 365 100  
7:00am to 9:00pm Monday to Friday AEST

\*Applicable local call and mobile charges apply.  
Online Helpdesk: <https://au.answers.acer.com/app/ask>

### Customers in New Zealand

Technical Support: 0800 223 769  
7:00am to 9:00pm Monday to Friday AEST  
9:00am to 6:00pm Saturday and Sunday AEST

Service and Repair Enquiries: 0800 223 769  
7:00am to 9:00pm Monday to Friday AEST

\*Applicable local call and mobile charges apply.  
Online Helpdesk: <https://au.answers.acer.com/app/ask>

# Safety Instruction



Do not attempt to service this product yourself, as opening or removing covers may expose you to dangerous voltage points or other risks. Refer all servicing to qualified service personnel. Unplug this product from the wall outlet and refer servicing to qualified service personnel when:

- The power cord or plug is damaged, cut or frayed.
- Liquid was spilled into the product.
- The product was exposed to rain or water.
- The product has been dropped or the case has been damaged.
- The product exhibits a distinct change in performance, indicating a need for service.
- The product does not operate normally after following the operating instructions.
- The product exhibits a distinct change in performance, indicating a need for service.
- The product does not operate normally after following the operating instructions.
- When unplugging the power cord, do not pull on the cord itself but pull on the plug.
- This product should be operated from the type of power indicated on the marking label.

## Environment

Temperature:  
- Operating: 5° C to 35° C  
- Storage: -20° C to 60° C

Humidity (non-condensing):  
- Operating: 20% to 80%  
- Storage: 20% to 60%

## USA – FCC and FAA

The FCC with its action in ET Docket 96-8 has adopted a safety standard for human exposure to radio frequency (RF) electromagnetic energy emitted by FCC certified equipment. The wireless adapter meets the Human Exposure limits found in OET Bulletin 65, supplement C, 2001, and ANSI/IEEE C95.1, 1992. Proper operation of this radio according to the instructions found in this manual will result in exposure substantially below the FCC's recommended limits.

- The following safety precautions should be observed: Do not touch or move antenna while the unit is transmitting or receiving.
- Do not hold any component containing the radio such that the antenna is very close or touching any exposed parts of the body, especially the face or eyes, while transmitting.
- Do not operate the radio or attempt to transmit data unless the antenna is connected; this behavior may cause damage to the radio.
- The use of wireless adapters in hazardous locations is limited by the constraints posed by the safety directors of such environments.
- The use of wireless adapters on airplanes is governed by the Federal Aviation Administration (FAA).
- The use of wireless adapters in hospitals is restricted to the limits set forth by each hospital. The product comply with the FCC portable RF exposure limit set forth for an uncontrolled environment and are safe for intended operation as described in this manual. The further RF exposure reduction can be achieved if the product can be kept as far as possible from the user body or set the device to lower output if such function is available.

## FCC radio frequency interference requirements

This device is restricted to indoor use due to its operation in the 5.15 to 5.25 GHz and 5.470 to 5.725 GHz frequency ranges. FCC requires this product to be used indoors for the frequency ranges 5.15 to 5.25 GHz and 5.470 to 5.725 GHz to reduce the potential for harmful interference to co-channel mobile satellite systems. High power radars are allocated as primary users of the 5.25 to 5.35 GHz and 5.65 to 5.85 GHz bands. These radar stations can cause interference with and /or damage this device. No configuration controls are provided for this wireless adapter allowing any change in the frequency of operations outside the FCC grant of authorization for U.S operation according to Part 15.407 of the FCC rules.

## FCC RF Radiation Exposure Statement

The radiated output power of the adapter is far below the FCC radio frequency exposure limits. Nevertheless, the adapter should be used in such a manner that the potential for human contact during normal operation is minimized. To avoid the possibility of exceeding the FCC radio frequency exposure limits, you should keep a distance of at least 20 cm between you (or any other person in the vicinity), or the minimum separation distance as specified by the FCC grant conditions, and the antenna that is built into the computer. Details of the authorized configurations can be found at [www.fcc.gov/oet/ea/](http://www.fcc.gov/oet/ea/) by entering the FCC ID number on the device.

- This Transmitter must not be co-located or operating in conjunction with any other antenna or transmitter.
- This equipment complies with FCC RF radiation exposure limits set forth for an uncontrolled environment. This equipment should be installed and operated with a minimum distance of 20 centimeters between the radiator and your body This device complies with Part 15 of the FCC Rules. Operation of the device is subject to the following two conditions:
- This device may not cause harmful interference.
- This device must accept any interference that may cause undesired operation.

## Canada – Industry Canada (IC) This device complies with RSS247 of Industry Canada.

Cet appareil se conforme à RSS247 de Canada d'Industrie. This device complies with Industry Canada licence-exempt RSS standard(s). Operation is subject to the following two conditions: (1) this device may not cause interference, and (2) this device must accept any interference, including interference that may cause undesired operation of the device. CAN ICES-3(B)/NMB-3(B) Le présent appareil est conforme aux CNR d'Industrie Canada applicables aux appareils radio exempts de licence. L'exploitation est autorisée aux deux conditions suivantes : (1) l'appareil ne doit pas produire de brouillage, et (2) l'utilisateur de l'appareil doit accepter tout brouillage radioélectrique subi, même si le brouillage est susceptible d'en compromettre le fonctionnement. CAN ICES-3(B)/NMB-3(B) Under Industry Canada regulations, this radio transmitter may only operate using an antenna of a type and maximum (or lesser) gain approved for the transmitter by Industry Canada. To reduce potential radio interference to other users, the antenna type and its gain should be so chosen that the equivalent isotropically radiated power (e.i.r.p.) is not more than that necessary for successful communication.

Conformément à la réglementation d'Industrie Canada, le présent émetteur radio peut fonctionner avec une antenne d'un type et d'un gain maximal (ou inférieur) approuvé pour l'émetteur par Industrie Canada. Dans le but de réduire les risques de brouillage radioélectrique à l'intention des autres utilisateurs, il faut choisir le type d'antenne et son gain de sorte que la puissance isotrope rayonnée équivalente (p.i.r.e.) ne dépasse pas l'intensité nécessaire à l'établissement d'une communication satisfaisante. Operation in the band 5150-5250 MHz is only for indoor use to reduce the potential for harmful interference to co-channel mobile satellite systems. La bande 5150-5250 MHz est réservée uniquement pour une utilisation à l'intérieur afin de réduire les risques de brouillage préjudiciable aux systèmes de satellites mobiles utilisant les mêmes canaux. Users are advised that high-power radars are allocated as primary users (i.e. priority users) of the bands 5250-5350 MHz and 5650-5850 MHz and that these radars could cause interference and/or damage to LE-LAN device Les utilisateurs êtes avisés que les utilisateurs de radars de haute puissance sont désignés utilisateurs principaux (c.-à-d., qu'ils ont la priorité) pour les bandes 5250-5350 MHz et 5650-5850 MHz et que ces radars pourraient causer du brouillage et/ou des dommages aux dispositifs LAN-EL.

## IC RF Radiation Exposure Statement:

This equipment complies with IC radiation exposure limits set forth for an uncontrolled environment. This equipment should be installed and operated with minimum distance which states in DoC between the radiator & your body. This transmitter must not be co-located or operating in conjunction with any other antenna or transmitter.

## Déclaration d'exposition aux radiations:

Cet équipement est conforme aux limites d'exposition aux rayonnements IC établies pour un environnement non contrôlé. Cet équipement doit être installé et utilisé avec un minimum de 20 cm de distance entre la source de rayonnement et votre corps.

## European Union

This product must be used in strict accordance with the regulations and constraints in the country of use. For further information, contact the local office in the country of use. Please see [https://europa.eu/european-union/about-eu/countries\\_en](https://europa.eu/european-union/about-eu/countries_en) for the latest country list. This equipment complies with the essential requirements of the European Union directive 2014/53/EU. See Statements of European Union Compliance, and more details refer to the attached Declaration of Conformity.

## EU RF Radiation Exposure Statement: [SAR]

This device meets the EU requirements on the limitation of exposure of the general public to electromagnetic fields by way of health protection. The limits are part of extensive recommendations for the protection of the general public. These recommendations have been developed and checked by independent scientific organizations through regular and thorough evaluations of scientific studies. The unit of measurement for the European Council's recommended limit for mobile devices is the "Specific Absorption Rate" (SAR), and the SAR limit is 2.0 W/kg averaged over 10 grams of body tissue. It meets the requirements of the International Commission on Non-Ionizing Radiation Protection (ICNIRP). For body worn operation, this device has been tested and meets the ICNIRP exposure guidelines and the European Standard, for use with dedicated accessories. Use of other accessories which contain metals may not ensure compliance with ICNIRP exposure guidelines. The low band 5.15 to 5.35 GHz is for indoor use only.

Compliant with Russian regulatory certification.

## Europäische Union

Dieses Produkt muss in Übereinstimmung mit den Richtlinien und Beschränkungen in dem Land, in dem es genutzt wird, verwendet werden. Weitere Informationen erhalten Sie von der lokalen Niederlassung in dem Land, in dem es genutzt wird. Bitte beachten Sie für die aktuellste Landesliste [https://europa.eu/european-union/about-eu/countries\\_en](https://europa.eu/european-union/about-eu/countries_en). Dieses Gerät erfüllt die wesentlichen Anforderungen der EU-Richtlinie 2014/53/EU. Beachten Sie die Konformitätserklärung der Europäischen Union. Weitere Einzelheiten finden Sie in der angehängten Konformitätserklärung.

## EU-Erklärung zur HF-Strahlenbelastung: [SAR]

Dieses Gerät erfüllt die EU-Anforderungen zur Begrenzung der Exposition der Bevölkerung gegenüber elektromagnetischen Feldern durch den Gesundheitsschutz. Die Begrenzungen sind Teil der umfassenden Empfehlungen für den Schutz der Bevölkerung. Diese Empfehlungen wurden durch unabhängige wissenschaftliche Organisationen durch reguläre und gründliche Evaluierungen wissenschaftlicher Studien entwickelt und geprüft. Das Maßeinheit des empfohlenen Grenzwertes des Europäischen Rates für Mobilgeräte ist die „spezifische Absorptionsrate (SAR)“, und die SAR-Grenze beträgt gemittelt 2,0 W/kg je 10 Gramm Körpergewebe. Es erfüllt die Anforderungen der International Commission on Non-Ionizing Radiation Protection (ICNIRP). Dieses Gerät wurde für den Betrieb am Körper getestet und erfüllt die ICNIRP-Expositionsrichtlinien und den Europäischen Standard für den Einsatz mit dediziertem Zubehör. Bei Verwendung anderer Zubehörartikel, die Metall enthalten, ist die Konformität mit den ICNIRP-Expositionsrichtlinien möglicherweise nicht mehr gewährleistet. Das niedrige Band 5,15 bis 5,35 GHz ist nur für den Einsatz im Innenbereich vorgesehen.















EÜ VASTAVUSDEKLARATSIOON



Meie, Acer Incorporated 8F, 8B, Sec. 1, Xintai 5th Rd., Xizhi, New Taipei City 221. Acer Italy s.r.l. Viale delle Industrie 1/A, 20044 Arese (MI), Italy Tel: +39 02 939 921, faks: +39-02 9399-2913

toode: Predator Connect Wi-Fi Router kaubamärk: acer W6 mudelinumber W6\* SKU number W6\* (\* on 0-9, a-z, "A-Z", "-", või lõik)

Meie, Acer Incorporated, kinnitame siinkohal enda ainuvastutusele, et eespool kirjeldatud toode vastab asjakohastele Euroopa Liidu ühtlustamise õigusaktidele: raadiosageduste direktiiv 2014/53/EL, RoHS-i direktiiv 2011/65/EL ja ökodisaini direktiiv 2009/125/EÜ. Rakendatud on järgmisi ühtlustatud standardeid ja/või teisi asjakohaseid standardeid:

Table with columns for standards: Elektromagnetiline ühilduvus (EN55032:2015+A11:2020, EN301489-17 V3.2.4), Raadiosageduse skaala kasutus (EN300328 V2.2.2, draft EN303687 V1.0.0), Tervis ja ohutus (EN62368-1:2014+A11:2017, EN IEC63000:2018), ERP (EU No.2019/1782; ENS0563:2011), 2400MHz-2483.5MHz <20dBm, 5150-5250, 5250-5350, 5470-5725, 5725-5850, 5945-6425MHz <23dBm

NB: 0197 TÜV Rheinland LGA Products GmbH. License Nr.: RT 60165519 0001

CE-märgistust hakatakse lisama alates:2022 RU Jan, Sr.Manager@New Taipei City 2022-10-16 Märkus: Avasge [Start Menu] (Start-menüü) ja otsige märksõna „Aceri dokumendid“, et saada abi võrguühenduse seadistamisel ja puteplaadi kasutamisel ning muud teavet, mis on oluline teie tervise ja ohutuse tagamiseks.



Izjava o uskladenosti



Proizvod: Predator Connect Wi-Fi Router Trgovacki naziv: acer Broj modela: W6 SKU broj: W6\* (\* je "0-9", "a-z", "A-Z", "-", ili razmak)

Meie, Acer Incorporated, kinnitame siinkohal enda ainuvastutusele, et eespool kirjeldatud toode vastab asjakohastele Euroopa Liidu ühtlustamise õigusaktidele: raadiosageduste direktiiv 2014/53/EL, RoHS-i direktiiv 2011/65/EL ja ökodisaini direktiiv 2009/125/EÜ. Rakendatud on järgmisi ühtlustatud standardeid ja/või teisi asjakohaseid standardeid:

Table with columns for standards: Elektromagnetna kompatibilnost (EN55032:2015+A11:2020, EN301489-17 V3.2.4), Korist ENje radio-frekv ENcijskog spektra (EN300328 V2.2.2, draft EN303687 V1.0.0), Zdravlje i sigurnost (EN62368-1:2014+A11:2017, EN IEC63000:2018), ERP (EU No.2019/1782; ENS0563:2011), 2400MHz-2483.5MHz <20dBm, 5150-5250, 5250-5350, 5470-5725, 5725-5850, 5945-6425MHz <23dBm

NB: 0197 TÜV Rheinland LGA Products GmbH. License Nr.: RT 60165519 0001

Godina za početak primjene CE označavanja:2022 Napomena: Otvorite izbornik [Start] (Početak) i tražite "Dokumenti za Acer" za pomoć pri podešavanju mrežne veze, korištenju dodirne ploče i drugih informacija važnih za zdravlje i sigurnost.



EK ATBILSTĪBAS DEKLARĀCIJA



Prece: Predator Connect Wi-Fi Router Tirdzniecības zīme: acer Modela numurs: W6 SKU numurs: W6\* (\* "0-9", "a-z", "A-Z", "-", vai tukšs)

Mēs, Acer Incorporated, ar šo paziņojām, ka zemāk norādītais produkts ir saskaņā ar atbilstošajiem savienības saskaņojošiem tiesību aktiem: Direktīva 2014/53/EŅ par radiofrekvenci, RoHS direktīva 2011/65/EŅ un ErP direktīva 2009/125/EŅ. Ir pielietoti turpmāk minētās saskaņotie standarti un/vai citi attiecīnāmie standarti:

Table with columns for standards: Elektromagnētiskā saderība (EN55032:2015+A11:2020, EN301489-1 V2.2.3), Radiorekv encies spektra izmantošana (EN300328 V2.2.2, draft EN303687 V1.0.0), Veselība un drošība (EN62368-1:2014+A11:2017, EN IEC63000:2018), ERP (EU No.2019/1782; ENS0563:2011), 2400MHz-2483.5MHz <20dBm, 5150-5250, 5250-5350, 5470-5725, 5725-5850, 5945-6425MHz <23dBm

NB: 0197 TÜV Rheinland LGA Products GmbH. License Nr.: RT 60165519 0001

Gads, kurā sāks ieviest CE marķējums:2022 Piezīme: Atveriet [Start] (Sākuma) izvēlni un meklējiet „Acer Documents“ tas palīdzēs jums uzstādīt jaunu tīkla savienojumu, izmantojot skārienpaneli, un sniegs citu svarīgu informāciju par jūsu veselību un drošību.



EÜ VASTAVUSDEKLARATSIOON



Meie, Acer Incorporated 8F, 8B, Sec. 1, Xintai 5th Rd., Xizhi, New Taipei City 221. Acer Italy s.r.l. Viale delle Industrie 1/A, 20044 Arese (MI), Italy Tel: +39 02 939 921, faks: +39-02 9399-2913

toode: Predator Connect Wi-Fi Router kaubamärk: acer W6 mudelinumber W6\* SKU number W6\* (\* on 0-9, a-z, "A-Z", "-", või lõik)

Meie, Acer Incorporated, kinnitame siinkohal enda ainuvastutusele, et eespool kirjeldatud toode vastab asjakohastele Euroopa Liidu ühtlustamise õigusaktidele: raadiosageduste direktiiv 2014/53/EL, RoHS-i direktiiv 2011/65/EL ja ökodisaini direktiiv 2009/125/EÜ. Rakendatud on järgmisi ühtlustatud standardeid ja/või teisi asjakohaseid standardeid:

Table with columns for standards: Elektromagnetiline ühilduvus (EN55032:2015+A11:2020, EN301489-17 V3.2.4), Raadiosageduse skaala kasutus (EN300328 V2.2.2, draft EN303687 V1.0.0), Tervis ja ohutus (EN62368-1:2014+A11:2017, EN IEC63000:2018), ERP (EU No.2019/1782; ENS0563:2011), 2400MHz-2483.5MHz <20dBm, 5150-5250, 5250-5350, 5470-5725, 5725-5850, 5945-6425MHz <23dBm

NB: 0197 TÜV Rheinland LGA Products GmbH. License Nr.: RT 60165519 0001

CE-märgistust hakatakse lisama alates:2022 RU Jan, Sr.Manager@New Taipei City 2022-10-16 Märkus: Avasge [Start Menu] (Start-menüü) ja otsige märksõna „Aceri dokumendid“, et saada abi võrguühenduse seadistamisel ja puteplaadi kasutamisel ning muud teavet, mis on oluline teie tervise ja ohutuse tagamiseks.



EB ATTIKTIES DEKLARACIJA



Gaminys: Predator Connect Wi-Fi Router Prekybinis: acer Modelio numeris W6 SKU numeris: W6\* (\* yra „0-9“, „a-z“, „A-Z“, „-“, arba tuščias)

Mēs, „Acer Incorporated“, savo išskirtine atsakomybe deklaruojame, kad pirmiau aprašytas gaminys atitinka galiojančius Sąjungos derinimo teisės aktus: Radijo ryšio įrangos direktyvą 2014/53/ES, RoHS direktyvą 2011/65/ES ir ErP direktyvą 2009/125/EB. Pritaikyti toliau nurodyti darnieji standartai ir (arba) kiti aktualūs standartai:

Table with columns for standards: Elektromagnetinis suderinamumas (EN55032:2015+A11:2020, EN301489-17 V3.2.4), Radijo ryšio dažnių spektro naudojimas (EN300328 V2.2.2, draft EN303687 V1.0.0), Saugumas (EN62368-1:2014+A11:2017, EN IEC63000:2018), ERP (EU No.2019/1782; ENS0563:2011), 2400MHz-2483.5MHz <20dBm, 5150-5250, 5250-5350, 5470-5725, 5725-5850, 5945-6425MHz <23dBm

NB: 0197 TÜV Rheinland LGA Products GmbH. License Nr.: RT 60165519 0001

Metai, nuo kada pradėtas klijuoti CE ženklas:2022 Pastaba: atverkite meniu [Start] (pradžią) ir suraskite „Acer dokumentai“, kad gautumėte pagalbą dėl tinklo ryšio nustatymo, jutiklio kilmėms naudojimui ir kitos jūsų sveikatai ir saugai svarbios informacijos.



DECLARAȚIA CE DE CONFORMITATE



Produs: Predator Connect Wi-Fi Router Nume comercial: acer Număr model W6 Număr SKU W6\* (\* este "0-9", "a-z", "A-Z", "-", sau spațiu)

Prin prezenta, Acer Incorporated declară pe propria răspundere că produsul descris mai sus respectă legislația relevantă armonizată a Uniunii: Directiva 2014/53/UE privind echipamentele radio, Directiva RoHS 2011/65/UE și Directiva ErP 2009/125/CE. Au fost aplicate următoarele standarde armonizate și/sau alte standarde relevante:

Table with columns for standards: Compatibilitate electromagnetică (EN55032:2015+A11:2020, EN301489-1 V2.2.3), Utilizarea spectrului de frecvențe radio (EN300328 V2.2.2, draft EN303687 V1.0.0), Sănătatea și siguranța (EN62368-1:2014+A11:2017, EN IEC63000:2018), ERP (EU No.2019/1782; ENS0563:2011), 2400MHz-2483.5MHz <20dBm, 5150-5250, 5250-5350, 5470-5725, 5725-5850, 5945-6425MHz <23dBm

NB: 0197 TÜV Rheinland LGA Products GmbH. License Nr.: RT 60165519 0001

An de începere a aplicării marcuilui CE:2022 Notă: Deschideți Meniu [Start] (Start) și căutați "Documente Acer", pentru ajutor privind configurarea unei conexiuni de rețea, utilizarea suportului tactil și alte informații importante pentru sănătatea și siguranța dvs.



Druža,  
Acer Incorporated  
8F, 8B, Sec. 1, Xintai 5th Rd., Xizhi,  
New Taipei City 221  
İletişim: Mr. RU Jan, e-mail: ru.jan@acer.com

İZJAVA ES O SKLADNOSTI

Acer Italy s.r.l.  
Viale delle Industrie 1/A, 20044 Arese (MI), Italy  
Tel: +39-02-939-921, Faks: +39-02-9399-2913



Federal Communications Commission  
Declaration of Conformity



Acer America Corporation  
333 West San Carlos St., Suite 1500  
San Jose, CA 95110 U.S.A.  
Tel: 1-254-298-4000  
Fax: 1-254-298-4147  
www.acer.com

This device complies with Part 15 of the FCC Rules. Operation is subject to the following two conditions: (1) this device may not cause harmful interference, and (2) this device must accept any interference received, including interference that may cause undesired operation.

The following Local Manufacturer / Importer is responsible for this declaration:

Product Type: Predator Connect Wi-Fi Router  
Trade Name: acer  
Model No.: W6  
SKU Name: W6\*\*\*\*\*  
(where \* is 0-9, a-z, A-Z, -, or blank)

Name of Responsible Party: Acer America Corporation  
Address of Responsible Party: 333 West San Carlos St., Suite 1500, San Jose, CA95110, U.S.A.  
Contact Person: Acer Representative  
Phone No.: 1-254-298-4000  
Fax No.: 1-254-298-4147

[USA]

\* FCC regulations restrict operation of this device to indoor use only.  
\* The operation of this device is prohibited on oil platforms, cars, trains, boats, and aircraft, except that operation of this device is permitted in large aircraft while flying above 10,000 feet.  
\* Operation of transmitters in the 5.925-7.125 GHz band is prohibited for control of or communications with unmanned aircraft systems.

\* This equipment has been tested and found to comply with the limits for a Class B digital device, pursuant to part 15 of the FCC rules. These limits are designed to provide reasonable protection against harmful interference in a residential installation.  
\* This equipment generates, uses and can radiate radio frequency energy and, if not installed and used in accordance with the instructions, may cause harmful interference to radio communications. However, there is no guarantee that interference will not occur in a particular installation. If this equipment does cause harmful interference to radio or television reception, which can be determined by turning the equipment off and on, the user is encouraged to try to correct the interference by one or more of the following measures:  
- Reorient or relocate the receiving antenna.  
- Increase the separation between the equipment and receiver.  
- Connect the equipment into an outlet on a circuit different from that to which the receiver is connected.  
- Consult the dealer or an experienced radio/TV technician for help.  
\* You are cautioned that changes or modifications not expressly approved by the part responsible for compliance could void the user's authority to operate the equipment.  
\* FCC RF Radiation Exposure Statement:  
- This Transmitter must not be co-located or operating in conjunction with any other antenna or transmitter.  
- This equipment complies with FCC RF radiation exposure limits set forth for an uncontrolled environment. This equipment should be installed and operated with a minimum distance of 20 centimeters between the radiator and your body.

[Canada] CAN ICES-3(B) / NMB-3(B)

\* The device for operation in the band 5150-5250 MHz is only for indoor use to reduce the potential for harmful interference to co-channel mobile satellite systems.  
\* This device contains licence-exempt transmitter(s)/receiver(s) that comply with Innovation, Science and Economic Development Canada's licence-exempt RSSI(s). Operation is subject to the following two conditions:  
- This device may not cause interference, and  
- This device must accept any interference, including interference that may cause undesired operation of the device.  
[Caution]: Exposure to Radio Frequency Radiation  
- To comply with the Canadian RF exposure compliance requirements, this device and its antenna must not be co-located or operating in conjunction with any other antenna or transmitter.  
- To comply with RSS 102 RF exposure compliance requirements, a separation distance of at least 20 cm must be maintained between the antenna of this device and all persons.

\* les dispositifs fonctionnant dans la bande de 5 150 à 5 250 MHz sont réservés uniquement pour une utilisation à l'intérieur afin de réduire les risques de brouillage préjudiciable aux systèmes de satellites mobiles utilisant les mêmes canaux/Note de bas de page  
L'émetteur/récepteur exempt de licence contenu dans le présent appareil est conforme aux CNR d'Innovation, Sciences et Développement économique Canada applicables aux appareils radio exempts de licence. L'exploitation est autorisée aux deux conditions suivantes :  
- l'appareil ne doit pas produire de brouillage, et  
- l'utilisateur de l'appareil doit accepter tout brouillage radioélectrique subi, même si le brouillage est susceptible d'en compromettre le fonctionnement.  
[Attention]: exposition au rayonnement radiofréquence  
- Pour se conformer aux exigences de conformité RF canadienne l'exposition, cet appareil et son antenne ne doivent pas être co-localisés ou fonctionnant en conjonction avec une autre antenne ou transmetteur.  
- Pour se conformer aux exigences de conformité CNR 102 RF exposition, une distance de séparation d'au moins 20 cm doit être maintenue entre l'antenne de cet appareil et toutes les personnes.

Open the Start Menu, search for "Acer Documents" for Setup, regulatory and important safety guide, or visit www.acer.com > support



Acer Incorporated  
8F, 8B, Sec. 1, Xintai 5th Rd., Xizhi,  
New Taipei City 221  
Contact Person: Mr. RU Jan, e-mail: RU.Jan@acer.com

UKCA DECLARATION OF CONFORMITY

We, Acer Incorporated, hereby declare under our sole responsibility that the product described above is in conformity with the relevant Union harmonization legislation as below regulation and the following harmonized standards and/or other relevant standards have been applied:  
Product: Predator Connect Wi-Fi Router  
Trade Name: acer  
Model Number: W6  
SKU Number: W6\*\*\*\*\*  
(\* is "0-9", "a-z", "A-Z", "-", or blank)

We, Acer Incorporated, hereby declare under our sole responsibility that the product described above is in conformity with the relevant Union harmonization legislation as below regulation and the following harmonized standards and/or other relevant standards have been applied:

Electromagnetic compatibility Regulation 2016	BS EN55032:2015+A11:2020	BS EN55035:2017	EN301489-1 V2.2.3
BS EN55032:2015+A11:2020	BS EN IEC61000-3-2:2019	EN301489-1 V3.2.4	BS EN61000-3-3:2013+A1:2019
Radio Equipment Regulation 2017	EN300328 V2.2.2	EN300440 V2.2.1	EN301893 V2.1.1
EN300328 V2.2.2	EN300440 V2.2.1	EN301893 V2.1.1	draft EN303687 V1.0.0
Electrical Equipment (Safety) Regulation 2016	BS EN62368-1:2014+A11:2017	EN62311:2020	
BS EN62368-1:2014+A11:2017	EN62311:2020		
RoHS in Electrical and Electronic Equipment Regulations 2012	EN IEC63000:2018		
The Ecodesign for Energy-Related Products Regulations 2019	(EU) No.2019/1782; EN50563:2011	(EC) No.1275/2008; EN50564:2011	
(EU) No.2019/1782; EN50563:2011	(EC) No.1275/2008; EN50564:2011		

2400MHz-2483.5MHz <20dBm, 5150-5250, 5250-5350, 5470-5725, 5725-5850, 5945-6425MHz <23dBm

NB: 0197 TÜV Rheinland LGA Products GmbH, License Nr.: RT 60165519 0001

Year to begin affixing UKCA marking:2022

Note: Open the Start Menu and search for "Acer Documents" for help with setting up a network connection, using the touchpad, and other information which is important for your health and safety.



Biz,  
Acer Incorporated  
8F, 8B, Sec. 1, Xintai 5th Rd., Xizhi,  
New Taipei City 221  
İletişim: Mr. RU Jan, e-posta: ru.jan@acer.com

Uyum Beyanı

Acer Italy s.r.l.  
Viale delle Industrie 1/A, 20044 Arese (MI), Italy  
Tel: +39-02-939-921, Faks: +39-02-9399-2913



Federal Communications Commission  
Declaration of Conformity



Acer America Corporation  
333 West San Carlos St., Suite 1500  
San Jose, CA 95110 U.S.A.  
Tel: 1-254-298-4000  
Fax: 1-254-298-4147  
www.acer.com

\* les dispositifs fonctionnant dans la bande de 5 150 à 5 250 MHz sont réservés uniquement pour une utilisation à l'intérieur afin de réduire les risques de brouillage préjudiciable aux systèmes de satellites mobiles utilisant les mêmes canaux/Note de bas de page  
L'émetteur/récepteur exempt de licence contenu dans le présent appareil est conforme aux CNR d'Innovation, Sciences et Développement économique Canada applicables aux appareils radio exempts de licence. L'exploitation est autorisée aux deux conditions suivantes :  
- l'appareil ne doit pas produire de brouillage, et  
- l'utilisateur de l'appareil doit accepter tout brouillage radioélectrique subi, même si le brouillage est susceptible d'en compromettre le fonctionnement.  
[Attention]: exposition au rayonnement radiofréquence  
- Pour se conformer aux exigences de conformité RF canadienne l'exposition, cet appareil et son antenne ne doivent pas être co-localisés ou fonctionnant en conjonction avec une autre antenne ou transmetteur.  
- Pour se conformer aux exigences de conformité CNR 102 RF exposition, une distance de séparation d'au moins 20 cm doit être maintenue entre l'antenne de cet appareil et toutes les personnes.

Open the Start Menu, search for "Acer Documents" for Setup, regulatory and important safety guide, or visit www.acer.com > support



Acer Incorporated  
8F, 8B, Sec. 1, Xintai 5th Rd., Xizhi,  
New Taipei City 221  
Contact Person: Mr. RU Jan, e-mail: RU.Jan@acer.com

UKCA DECLARATION OF CONFORMITY

We, Acer Incorporated, hereby declare under our sole responsibility that the product described above is in conformity with the relevant Union harmonization legislation as below regulation and the following harmonized standards and/or other relevant standards have been applied:  
Product: Predator Connect Wi-Fi Router  
Trade Name: acer  
Model Number: W6  
SKU Number: W6\*\*\*\*\*  
(\* is "0-9", "a-z", "A-Z", "-", or blank)

We, Acer Incorporated, hereby declare under our sole responsibility that the product described above is in conformity with the relevant Union harmonization legislation as below regulation and the following harmonized standards and/or other relevant standards have been applied:

Electromagnetic compatibility Regulation 2016	BS EN55032:2015+A11:2020	BS EN55035:2017	EN301489-1 V2.2.3
BS EN55032:2015+A11:2020	BS EN IEC61000-3-2:2019	EN301489-1 V3.2.4	BS EN61000-3-3:2013+A1:2019
Radio Equipment Regulation 2017	EN300328 V2.2.2	EN300440 V2.2.1	EN301893 V2.1.1
EN300328 V2.2.2	EN300440 V2.2.1	EN301893 V2.1.1	draft EN303687 V1.0.0
Electrical Equipment (Safety) Regulation 2016	BS EN62368-1:2014+A11:2017	EN62311:2020	
BS EN62368-1:2014+A11:2017	EN62311:2020		
RoHS in Electrical and Electronic Equipment Regulations 2012	EN IEC63000:2018		
The Ecodesign for Energy-Related Products Regulations 2019	(EU) No.2019/1782; EN50563:2011	(EC) No.1275/2008; EN50564:2011	
(EU) No.2019/1782; EN50563:2011	(EC) No.1275/2008; EN50564:2011		

2400MHz-2483.5MHz <20dBm, 5150-5250, 5250-5350, 5470-5725, 5725-5850, 5945-6425MHz <23dBm

NB: 0197 TÜV Rheinland LGA Products GmbH, License Nr.: RT 60165519 0001

Year to begin affixing UKCA marking:2022

Note: Open the Start Menu and search for "Acer Documents" for help with setting up a network connection, using the touchpad, and other information which is important for your health and safety.

NB: 0197 TÜV Rheinland LGA Products GmbH, License Nr.: RT 60165519 0001

CE işaretinin takilmaya başladığı yıl:2022

Not: [Start] (Başlat) Menüsinin açın ve dokunmatik yüzeyi kullanarak bir ağ bağlantısı oluşturmaya yardımcı olmak için "Acer Belgeleri" kısmını arayın ve sağlığınıza ve güvenliğinize için önemli olan diğer bilgileri araştırın.



03.7701.337003-000