

Partial FCC Test Report

EQUIPMENT : Notebook Computer
BRAND NAME : ACER, GATEWAY, PACKARD BELL
MODEL NAME : ZG8, Aspire one, AO530
FCC ID : HLZUNDP-1Q
STANDARD : 47 CFR Part 2, 22(H), 24(E)
CLASSIFICATION : PCS Licensed Transmitter (PCB)
Tx/Rx FREQUENCY RANGE : GSM850 : 824.2 ~ 848.8 MHz /
869.2 ~ 893.8 MHz
GSM1900 : 1850.2 ~ 1909.8 MHz /
1930.2 ~ 1989.8 MHz
WCDMA Band V : 826.4 ~ 846.6 MHz /
871.4 ~ 891.6 MHz
WCDMA Band II : 1852.4 ~ 1907.6 MHz /
1932.4 ~ 1987.6 MHz
MAX. ERP/EIRP POWER : GSM850(GPRS) : 0.80 W
GSM850(EDGE) : 0.24 W
GSM1900(GPRS) : 0.13 W
GSM1900(EDGE) : 0.05 W
WCDMA Band V : 0.11 W
WCDMA Band II : 0.06 W
APPLICANT : Acer Inc.
8F, No. 88, Sec.1, Hsin Tai Wu Rd., Hsichih, Taipei Hsien
221, Taiwan, R.O.C.

This is a partial report which is only valid combined with the Integrated WWAN Module (Qualcomm / model name: Gobi 1000, FCC ID: J9CUNDP-1) Report.

The product sample received on Feb. 11, 2009 and completely tested on Mar. 03, 2009. We, SPORTON INTERNATIONAL INC., would like to declare that the tested sample has been evaluated in accordance with the procedures given in ANSI C63.4-2003 and shown compliance with the applicable technical standards.

The test results in this report apply exclusively to the tested model / sample. Without written approval of SPORTON INTERNATIONAL INC., the test report shall not be reproduced except in full.



Reviewed by: Roy Wu / Manager



SPORTON INTERNATIONAL INC.

No. 52, Hwa Ya 1st Rd., Hwa Ya Technology Park, Kwei-Shan Hsiang, Tao Yuan Hsien, Taiwan, R.O.C.



TABLE OF CONTENTS

REVISION HISTORY..... 3

SUMMARY OF TEST RESULT 4

1 GENERAL DESCRIPTION 5

 1.1 Applicant..... 5

 1.2 Manufacturer 5

 1.3 Feature of Equipment Under Test..... 6

 1.4 Testing Site 7

 1.5 Applied Standards 8

 1.6 Ancillary Equipment List..... 8

2 TEST CONFIGURATION OF EQUIPMENT UNDER TEST 9

 2.1 Test Mode..... 9

 2.2 Connection Diagram of Test System 10

3 TEST RESULT..... 11

 3.1 Conducted Output Power Measurement..... 11

 3.2 Band Edge Measurement..... 14

 3.3 Effective Radiated Power and Effective Isotropic Radiated Power Measurement 39

 3.4 Field Strength of Spurious Radiation Measurement 45

4 LIST OF MEASURING EQUIPMENTS 61

5 UNCERTAINTY OF EVALUATION 62

6 CERTIFICATION OF TAF ACCREDITATION 63

APPENDIX A. PHOTOGRAPHS OF EUT

APPENDIX B. SETUP PHOTOGRAPHS



SUMMARY OF TEST RESULT

Report Section	FCC Rule	IC Rule	Description	Limit	Result
3.1	§2.1046	N/A	Conducted Output Power	N/A	PASS
3.2	§2.1051 §22.917(a) §24.238(a)	RSS-132 (4.5.1) RSS-133 (6.5.1)	Band Edge Measurement	$< 43 + 10 \log_{10}(P[\text{Watts}])$	PASS
3.3	§22.913(a)(2)	RSS-132(4.4) SRSP-503(5.1.3)	Effective Radiated Power	< 7 Watts for FCC (< 6.3 Watts for IC)	PASS
3.3	§24.232(c)	RSS-133 (6.4) SRSP-510(5.1.2)	Equivalent Isotropic Radiated Power	< 2 Watts	PASS
3.4	§2.1053 §22.917(a) §24.238(a)	RSS-132 (4.5.1) RSS-133 (6.5.1)	Field Strength of Spurious Radiation	$< 43 + 10 \log_{10}(P[\text{Watts}])$	PASS

1 General Description

1.1 Applicant

Acer Inc.

8F, No. 88, Sec.1, Hsin Tai Wu Rd., Hsichih, Taipei Hsien 221, Taiwan, R.O.C.

1.2 Manufacturer

Quanta Computer Inc.

1. No. 2, Lane 58, Sanzhuang Road, Songjiang Export Processing Zone, Shanghai, P.R.C.
2. No. 4, Wen Ming 1st Street, Kuei Shan Hsiang, Taoyuan Shien 333, Taiwan, R.O.C.
3. No. 8, Dongjing Rd., Songjiang Industrial Zone, Shanghai, P.R.C.
4. No. 4, Lane 58, Sanzhuang Road, Songjiang Export Processing Zone, Shanghai, P.R.C.
5. North to Songsheng Road, Songjiang Industrial Zone, Shanghai, P.R.C.
6. B#, No. 1, South Rongteng Road, Songjiang Export Processing Zone, Shanghai, P.R.C.
7. Standard Factory, South to Valqua, Rongxin Road, Songjiang Export Processing Zone, Shanghai, P.R.C.
8. C#, No. 1, South Rongteng Road, Songjiang Export Processing Zone, Shanghai, P.R.C.
9. No. 6, Lane 66, Sanzhuang Road, Songjiang Export Processing Zone, Shanghai, P.R.C.
10. No. 6, Lane 58, Sanzhuang Road, Songjiang Export Processing Zone, Shanghai, P.R.C.
11. Huade Building, No. 18, ChuangYe Rd., ShandDi Zone, HaiDian District, Beijing, P.R.C.
12. No. 68, Sanzhuang Road, Songjiang Export Processing Zone, Shanghai, P.R.C.
13. 2F, C Building, XinYe Rd., Export Processing District In Torch, Zhongshan, Guangdong, P.R.C.



1.3 Feature of Equipment Under Test

Product Feature & Specification	
Equipment	Notebook Computer
Brand Name	ACER, GATEWAY, PACKARD BELL
Model Name	ZG8, Aspire one, AO530
FCC ID	HLZUNDP-1Q
Tx Frequency	GSM850 : 824 MHz ~ 849 MHz GSM1900 : 1850 MHz ~ 1910 MHz WCDMA Band V : 824 MHz ~ 849 MHz WCDMA Band II : 1850 MHz ~ 1910 MHz WLAN : 2400 MHz ~ 2483.5 MHz
Rx Frequency	GSM850 : 869 MHz ~ 894 MHz GSM1900 : 1930 MHz ~ 1990 MHz WCDMA Band V : 869 MHz ~ 894 MHz WCDMA Band II : 1930 MHz ~ 1990 MHz WLAN : 2400 MHz ~ 2483.5 MHz
Maximum Output Power to Antenna	GSM850(GPRS 8) : 32.68 dBm GSM1900(GPRS 8) : 29.75 dBm WCDMA Band V : 24.51 dBm WCDMA Band II : 24.32 dBm
Maximum ERP/EIRP	GSM850(GPRS 8) : 0.80 W (29.04 dBm) GSM850(EDGE 8) : 0.24 W (23.81 dBm) GSM1900(GPRS 8) : 0.13 W (21.10 dBm) GSM1900(EDGE 8) : 0.05 W (17.38 dBm) WCDMA Band V : 0.11 W (20.36 dBm) WCDMA Band II : 0.06 W (17.67 dBm)
Antenna Type	Fixed Internal Antenna
GPRS / EGPRS Multislot class	10
Type of Modulation	GSM / GPRS : GMSK EDGE : 8PSK WCDMA : QPSK HSDPA : QPSK / 16QAM 802.11b : DSSS 802.11g : OFDM
EUT Stage	Production Unit

List of Accessory:

Specification of Accessory		
AC Adapter	Brand Name	DELTA
	Model Name	ADP-30JH B
	Power Rating	I/P:100-240Vac, 50-60Hz, 1.2A; O/P: 19Vdc, 1.58A
	AC Power Cord Type	1.5 meter shielded cable with ferrite core
Battery	Brand Name	SIMPLO
	Model Name	UM09A75
	Power Rating	11.1Vdc, 2200mAh, 23Wh
	Type	Li-ion
WWAN Module	Brand Name	Qualcomm
	Model Name	Gobi 1000
WLAN Module	Brand Name	Atheros
	Model Name	AR5BHB63

Remark:

1. The above EUT's information was declared by manufacturer. Please refer to the specifications or user's manual for more detailed description.
2. For accessories equipped with this EUT, please refer to the appendix of the external photo.

1.4 Testing Site

Test Site	SPORTON INTERNATIONAL INC.		
Test Site Location	No. 52, Hwa Ya 1 st Rd., Hwa Ya Technology Park, Kwei-Shan Hsiang, Tao Yuan Hsien, Taiwan, R.O.C. TEL: +886-3-327-3456 FAX: +886-3-328-4978		
Test Site No.	Sporton Site No.		FCC/IC Registration No.
	TH02-HY	03CH07-HY	TW1022/4086B-1



1.5 Applied Standards

According to the specifications of the manufacturer, the EUT must comply with the requirements of the following standards:

- Preliminary Guidance for Receiving Applications for Certification of 3G Device. May 9, 2006.
- 47 CFR Part 2, 22(H), 24(E)
- ANSI C63.4-2003
- ANSI / TIA / EIA-603-C-2004
- IC RSS-132 Issued 2
- IC RSS-133 Issued 5

Remark:

1. All test items were verified and recorded according to the standards and without any deviation during the test.
2. This EUT has also been tested and complied with the requirements of FCC Part 15, Subpart B (DoC), recorded in a separate test report.

1.6 Ancillary Equipment List

Item	Equipment	Trade Name	Model No.	FCC ID	Data Cable	Power Cord
1.	System Simulator	Agilent	8960	N/A	N/A	Unshielded, 1.8 m

2 Test Configuration of Equipment Under Test

2.1 Test Mode

During all testing, EUT is in link mode with base station emulator at maximum power level. The spurious emission measurements were carried out in semi-anechoic chamber with 3-meter test range, and EUT is rotated on three test planes to find out the worst emission.

Frequency range investigated for radiated emission is as follows:

1. 30 MHz to 9000 MHz for GSM850 and WCDMA Band V
2. 30MHz to 19000 MHz for GSM1900 and WCDMA Band II.

Test Modes		
Band	Radiated TCs	Conducted TCs
GSM 850	<ul style="list-style-type: none"> ■ GPRS Link ■ EDGE Link ■ GPRS Link + WLAN Link 	<ul style="list-style-type: none"> ■ GPRS Link ■ EDGE Link
GSM 1900	<ul style="list-style-type: none"> ■ GPRS Link ■ EDGE Link 	<ul style="list-style-type: none"> ■ GPRS Link ■ EDGE Link
WCDMA Band V	<ul style="list-style-type: none"> ■ WCDMA Link 	<ul style="list-style-type: none"> ■ WCDMA Link ■ HSDPA Link
WCDMA Band II	<ul style="list-style-type: none"> ■ WCDMA Link 	<ul style="list-style-type: none"> ■ WCDMA Link ■ HSDPA Link

Note:

1. The conducted test item can be referred to WWAN Module (Qualcomm / model name: Gobi 1000, FCC ID: J9CUNDP-1) Report.
2. The maximum power levels are GPRS/EDGE multi-slot class 8 modes, only these modes used for all testing.

2.2 Connection Diagram of Test System

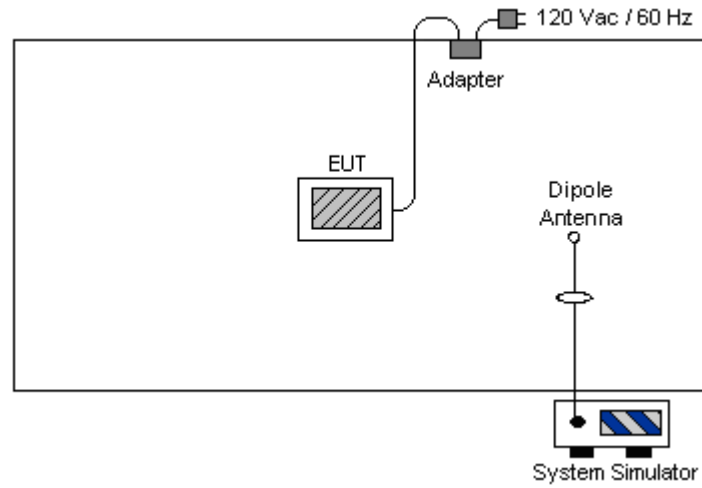

3 Test Result

3.1 Conducted Output Power Measurement

3.1.1 Description of the Conducted Output Power Measurement

A base station simulator was used to establish communication with the EUT. Its parameters were set to transmit the maximum power on the EUT. The measured power in the radio frequency on the transmitter output terminals shall be reported.

3.1.2 Measuring Instruments

See list of measuring instruments of this test report.

3.1.3 Test Procedures

1. The transmitter output port was connected to base station.
2. Set EUT at maximum power through base station.
3. Select lowest, middle, and highest channels for each band and different modulation.

3.1.4 Test Setup

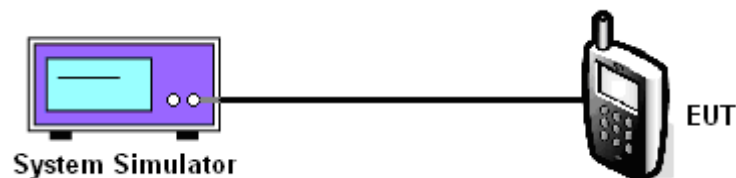



3.1.5 Test Result of Conducted Output Power

Cellular					
Modes	Channel	Frequency (MHz)	Conducted Power		
			(dBm)	(Watts)	
GPRS 8	128 (Low)	824.2	32.64	1.84	
	189 (Mid)	836.4	32.63	1.83	
	251 (High)	848.8	32.68	1.85	
GPRS 10	128 (Low)	824.2	32.61	1.82	
	189 (Mid)	836.4	32.58	1.81	
	251 (High)	848.8	32.62	1.83	
EDGE 8	128 (Low)	824.2	27.25	0.53	
	189 (Mid)	836.4	27.33	0.54	
	251 (High)	848.8	27.21	0.53	
EDGE 10	128 (Low)	824.2	27.22	0.53	
	189 (Mid)	836.4	27.13	0.52	
	251 (High)	848.8	27.14	0.52	
WCDMA Band V	12.2k bps	4132 (Low)	826.4	24.51	0.28
		4182 (Mid)	836.4	24.30	0.27
		4233 (High)	846.6	24.25	0.27
	HSDPA (2/15)	4132 (Low)	826.4	24.40	0.28
		4182 (Mid)	836.4	24.27	0.27
		4233 (High)	846.6	24.26	0.27
	HSDPA (12/15)	4132 (Low)	826.4	23.70	0.23
		4182 (Mid)	836.4	23.58	0.23
		4233 (High)	846.6	23.22	0.21
	HSDPA (15/8)	4132 (Low)	826.4	23.51	0.22
		4182 (Mid)	836.4	23.25	0.21
		4233 (High)	846.6	22.91	0.20
	HSDPA (15/4)	4132 (Low)	826.4	23.03	0.20
		4182 (Mid)	836.4	22.74	0.19
		4233 (High)	846.6	22.44	0.18



PCS					
Modes	Channel	Frequency (MHz)	Conducted Power		
			(dBm)	(Watts)	
GPRS 8	512 (Low)	1850.2	29.72	0.94	
	661 (Mid)	1880.0	29.75	0.94	
	810 (High)	1909.8	29.66	0.92	
GPRS 10	512 (Low)	1850.2	29.67	0.93	
	661 (Mid)	1880.0	29.70	0.93	
	810 (High)	1909.8	29.62	0.92	
EDGE 8	512 (Low)	1850.2	26.69	0.47	
	661 (Mid)	1880.0	26.81	0.48	
	810 (High)	1909.8	26.80	0.48	
EDGE 10	512 (Low)	1850.2	26.63	0.46	
	661 (Mid)	1880.0	26.74	0.47	
	810 (High)	1909.8	26.75	0.47	
WCDMA Band II	12.2k bps	9262 (Low)	1852.4	24.32	0.27
		9400 (Mid)	1880.0	24.31	0.27
		9538 (High)	1907.6	24.25	0.27
	HSDPA (2/15)	9262 (Low)	1852.4	24.11	0.26
		9400 (Mid)	1880.0	24.14	0.26
		9538 (High)	1907.6	24.03	0.25
	HSDPA (12/15)	9262 (Low)	1852.4	23.42	0.22
		9400 (Mid)	1880.0	23.43	0.22
		9538 (High)	1907.6	23.51	0.22
	HSDPA (15/8)	9262 (Low)	1852.4	23.09	0.20
		9400 (Mid)	1880.0	23.15	0.21
		9538 (High)	1907.6	23.05	0.20
	HSDPA (15/4)	9262 (Low)	1852.4	22.73	0.19
		9400 (Mid)	1880.0	22.68	0.19
		9538 (High)	1907.6	22.62	0.18

3.2 Band Edge Measurement

3.2.1 Description of Band Edge Measurement

The power of any emission outside of the authorized operating frequency ranges must be lower than the transmitter power (P) by a factor of at least $43 + 10 \log (P)$ dB.

3.2.2 Measuring Instruments

See list of measuring instruments of this test report.

3.2.3 Test Procedures

The band edges of low and high channels for the highest RF powers were measured. Setting RBW as roughly $BW/100$.

3.2.4 Test Setup

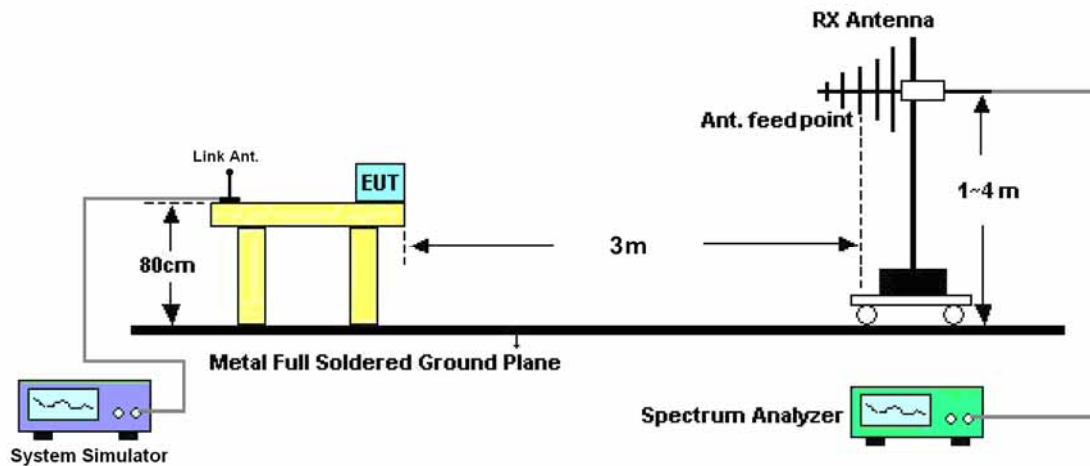



3.2.5 Test Result of Radiated Band Edge

Band :	GSM850	Temperature :	24~26°C
Test Mode :	GPRS Link	Relative Humidity :	41~43%
Test Engineer :	Elvis Chen	Polarization :	Horizontal
Remark :	Lower Band Edge Plot on Channel 128		

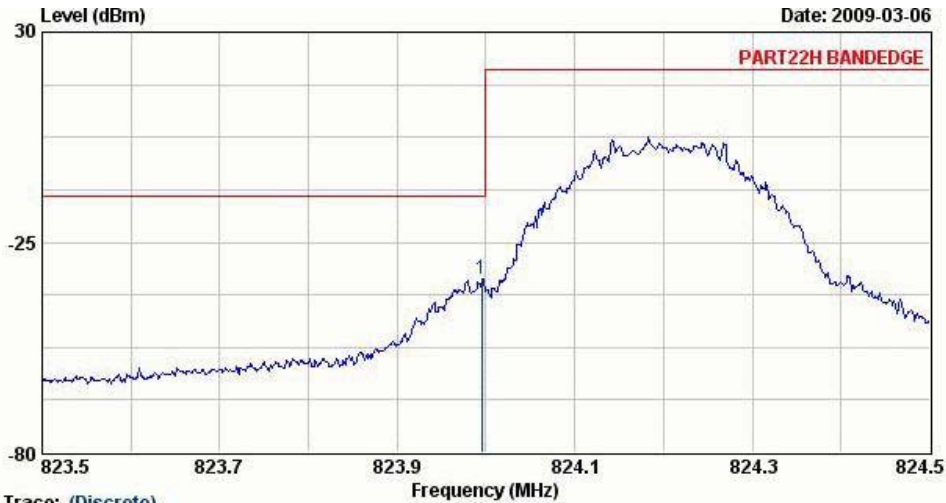

Trace: (Discrete)
 Site : 03CH07-HY
 Condition : PART22H BANDEDGE LF-EIRP(080719)-H HORIZONTAL
 Project : FG 921118

	Freq	Level	Over	Limit	Read	Factor	Remark
	MHz	dBm	dB	dBm	dBm	dB	
1 @	824.00	-34.43	-21.43	-13.00	-37.74	3.31	Peak



Band :	GSM850	Temperature :	24~26°C
Test Mode :	GPRS Link	Relative Humidity :	41~43%
Test Engineer :	Elvis Chen	Polarization :	Vertical
Remark :	Lower Band Edge Plot on Channel 128		

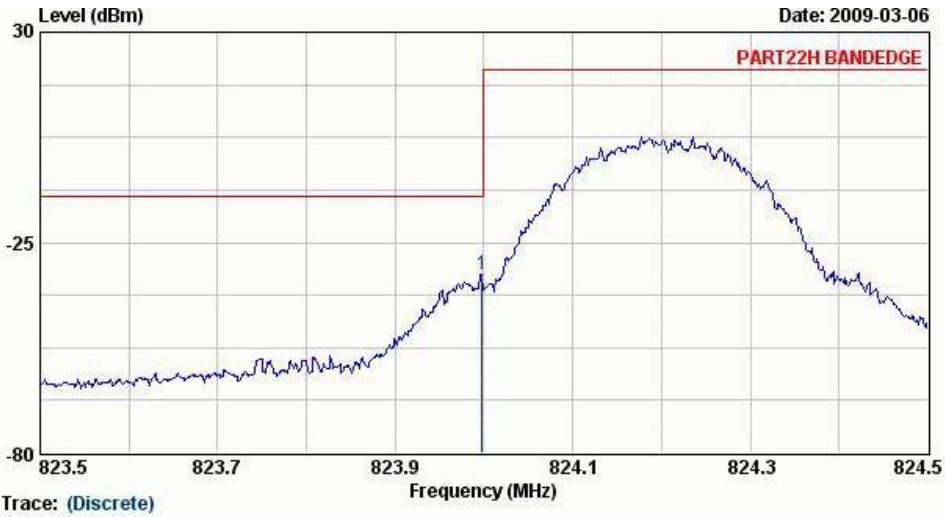

Trace: (Discrete)
 Site : 03CH07-HY
 Condition : PART22H BANDEDGE LF-EIRP(080719)-V VERTICAL
 Project : FG 921118

	Freq	Level	Over	Limit	Read		Remark
	MHz	dBm	dB	dBm	dBm	dB	
1 @	824.00	-33.43	-20.43	-13.00	-37.73	4.30	Peak



Band :	GSM850	Temperature :	24~26°C
Test Mode :	GPRS Link	Relative Humidity :	41~43%
Test Engineer :	Elvis Chen	Polarization :	Horizontal
Remark :	Higher Band Edge Plot on Channel 251		

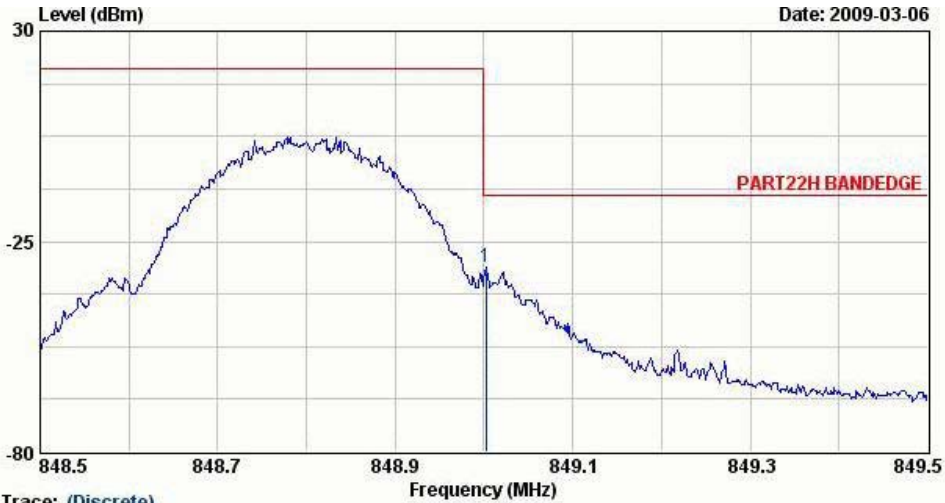

Trace: (Discrete)
 Site : 03CH07-HY
 Condition : PART22H BANDEDGE LF-EIRP(080719)-H HORIZONTAL
 Project : FG 921118

	Freq	Level	Over	Limit	Read		
	MHz	dBm	Limit	Line	Level	Factor	Remark
			dB	dBm	dBm	dB	
1 @	849.00	-31.94	-18.94	-13.00	-35.48	3.54	Peak



Band :	GSM850	Temperature :	24~26°C
Test Mode :	GPRS Link	Relative Humidity :	41~43%
Test Engineer :	Elvis Chen	Polarization :	Vertical
Remark :	Higher Band Edge Plot on Channel 251		

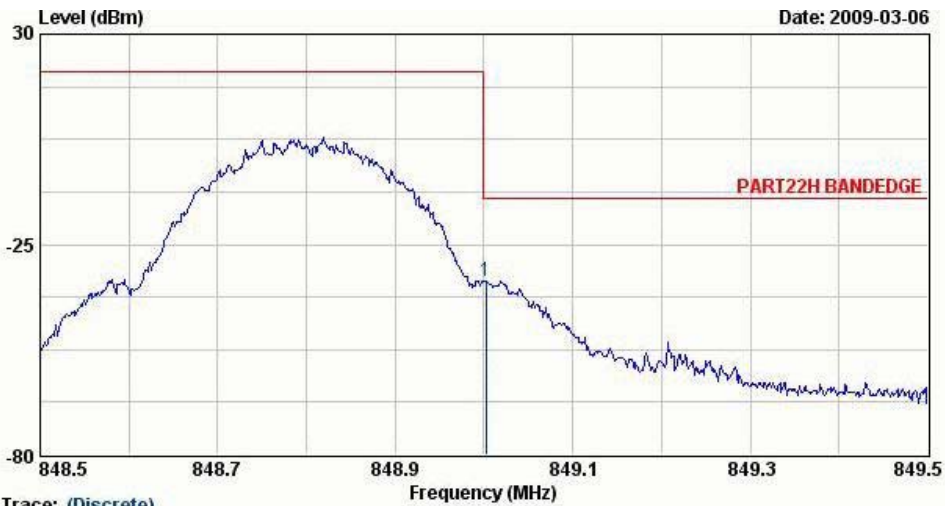

Trace: (Discrete)
 Site : 03CH07-HY
 Condition : PART22H BANDEDGE LF-EIRP(080719)-V VERTICAL
 Project : FG 921118

	Freq	Level	Over	Limit	Read		
	MHz	dBm	Limit	Line	Level	Factor	Remark
			dB	dBm	dBm	dB	
1 @	849.00	-34.67	-21.67	-13.00	-39.13	4.46	Peak



Band :	GSM850	Temperature :	24~26°C
Test Mode :	EDGE Link	Relative Humidity :	41~43%
Test Engineer :	Elvis Chen	Polarization :	Horizontal
Remark :	Lower Band Edge Plot on Channel 128		

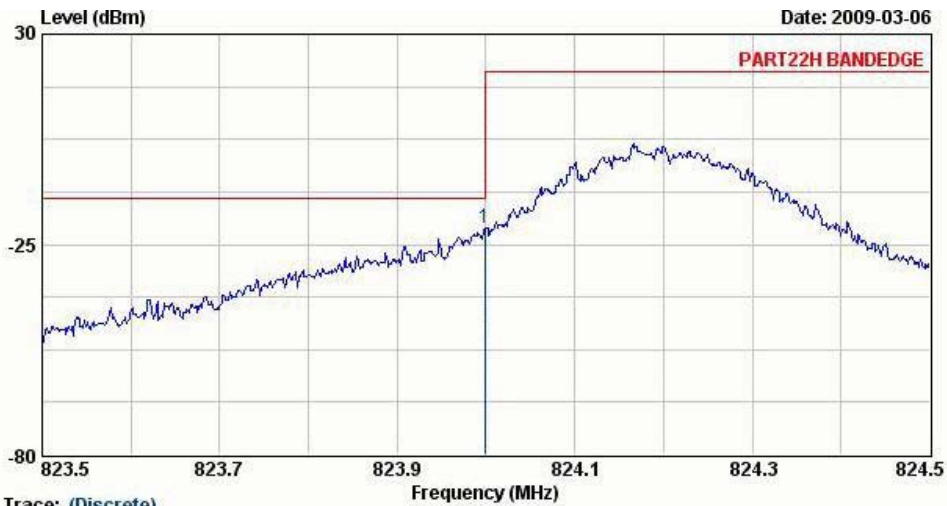

Trace: (Discrete)
 Site : 03CH07-HY
 Condition : PART22H BANDEDGE LF-EIRP(080719)-H HORIZONTAL
 Project : FG 921118

	Freq	Level	Over	Limit	Read		
	MHz	dBm	Limit	Line	Level	Factor	Remark
			dB	dBm	dBm	dB	
1 @	824.00	-20.62	-7.62	-13.00	-23.93	3.31	Peak



Band :	GSM850	Temperature :	24~26°C
Test Mode :	EDGE Link	Relative Humidity :	41~43%
Test Engineer :	Elvis Chen	Polarization :	Vertical
Remark :	Lower Band Edge Plot on Channel 128		

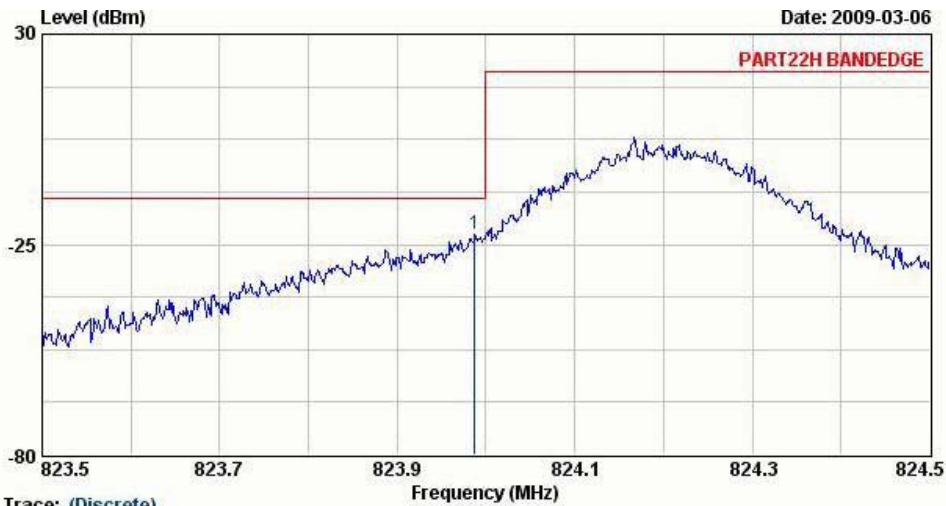

Trace: (Discrete)
 Site : 03CH07-HY
 Condition : PART22H BANDEDGE LF-EIRP(080719)-V VERTICAL
 Project : FG 921118

	Freq	Level	Over	Limit	Read		
	MHz	dBm	Limit	Line	Level	Factor	Remark
			dB	dBm	dBm	dB	
1	823.99	-22.14	-9.14	-13.00	-26.45	4.30	Peak



Band :	GSM850	Temperature :	24~26°C
Test Mode :	EDGE Link	Relative Humidity :	41~43%
Test Engineer :	Elvis Chen	Polarization :	Horizontal
Remark :	Higher Band Edge Plot on Channel 251		

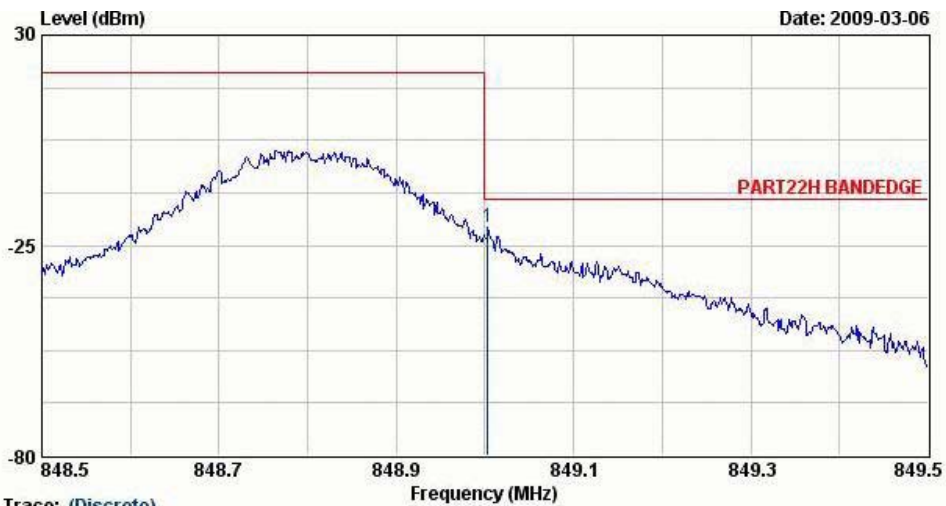

Trace: (Discrete)
 Site : 03CH07-HY
 Condition : PART22H BANDEDGE LF-EIRP(080719)-H HORIZONTAL
 Project : FG 921118

	Freq	Level	Over Limit	Limit Line	Read Level	Factor	Remark
	MHz	dBm	dB	dBm	dBm	dB	
1 @	849.00	-20.10	-7.10	-13.00	-23.64	3.54	Peak



Band :	GSM850	Temperature :	24~26°C
Test Mode :	EDGE Link	Relative Humidity :	41~43%
Test Engineer :	Elvis Chen	Polarization :	Vertical
Remark :	Higher Band Edge Plot on Channel 251		

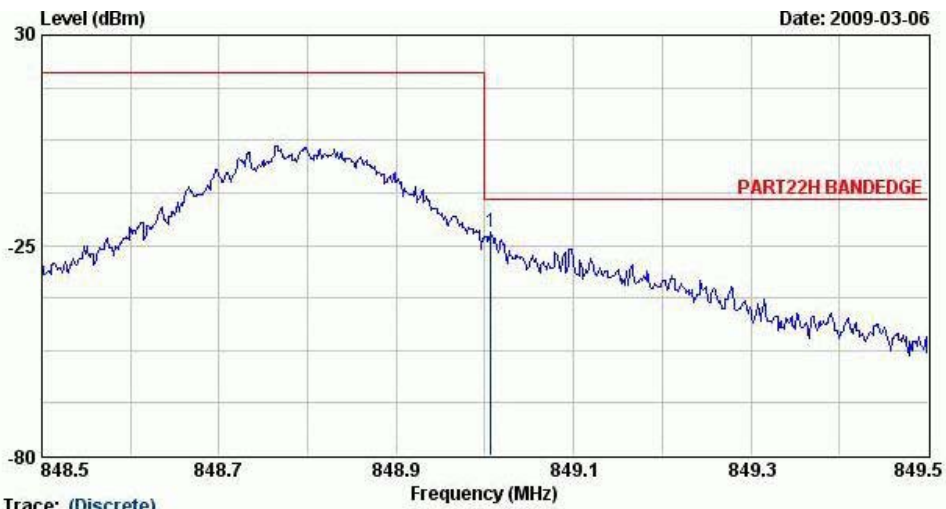

Trace: (Discrete)
 Site : 03CH07-HY
 Condition : PART22H BANDEGE LF-EIRP(080719)-V VERTICAL
 Project : FG 921118

	Freq	Level	Over	Limit	Read		
	MHz	dBm	Limit	Line	Level	Factor	Remark
			dB	dBm	dBm	dB	
1	849.01	-21.59	-8.59	-13.00	-26.05	4.46	Peak



Band :	GSM1900	Temperature :	24~26°C
Test Mode :	GPRS Link	Relative Humidity :	41~43%
Test Engineer :	Elvis Chen	Polarization :	Horizontal
Remark :	Lower Band Edge Plot on Channel 512		

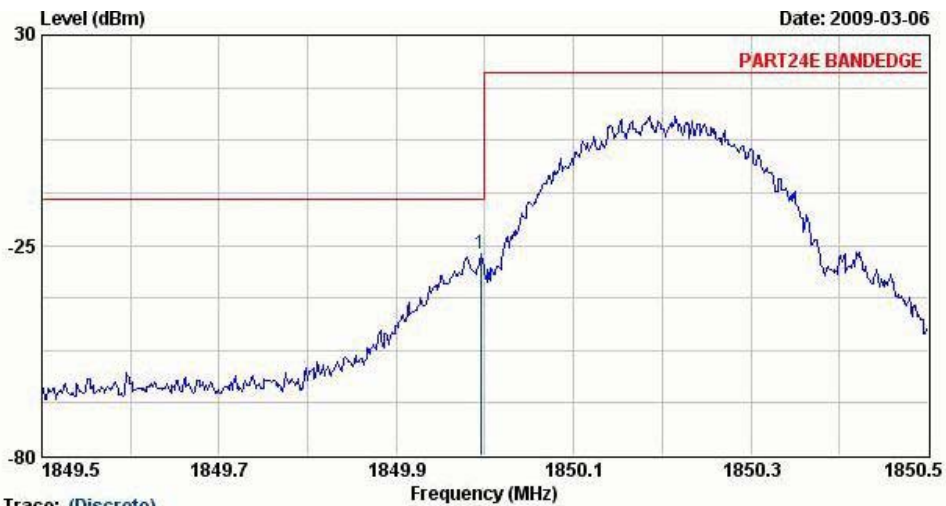

Trace: (Discrete)
 Site : 03CH07-HY
 Condition : PART24E BANDEDGE HF-EIRP(080306) HORIZONTAL
 Project : FG 921118

	Freq	Level	Over	Limit	Read		
	MHz	dBm	Limit	Line	Level	Factor	Remark
			dB	dBm	dBm	dB	
1 @	1850.00	-27.20	-14.20	-13.00	-35.99	8.79	Peak



Band :	GSM1900	Temperature :	24~26°C
Test Mode :	GPRS Link	Relative Humidity :	41~43%
Test Engineer :	Elvis Chen	Polarization :	Vertical
Remark :	Lower Band Edge Plot on Channel 512		

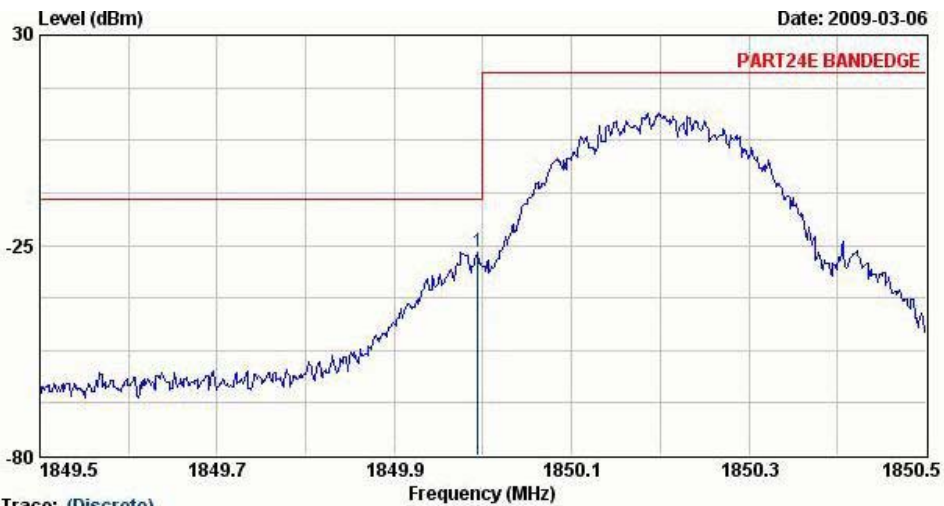

Trace: (Discrete)
 Site : 03CH07-HY
 Condition : PART24E BANDEDGE HF-EIRP(080306) VERTICAL
 Project : FG 921118

	Freq	Level	Over Limit	Limit Line	Read Level	Factor	Remark
	MHz	dBm	dB	dBm	dBm	dB	
1 @	1849.99	-26.79	-13.79	-13.00	-37.89	11.09	Peak



Band :	GSM1900	Temperature :	24~26°C
Test Mode :	GPRS Link	Relative Humidity :	41~43%
Test Engineer :	Elvis Chen	Polarization :	Horizontal
Remark :	Higher Band Edge Plot on Channel 810		

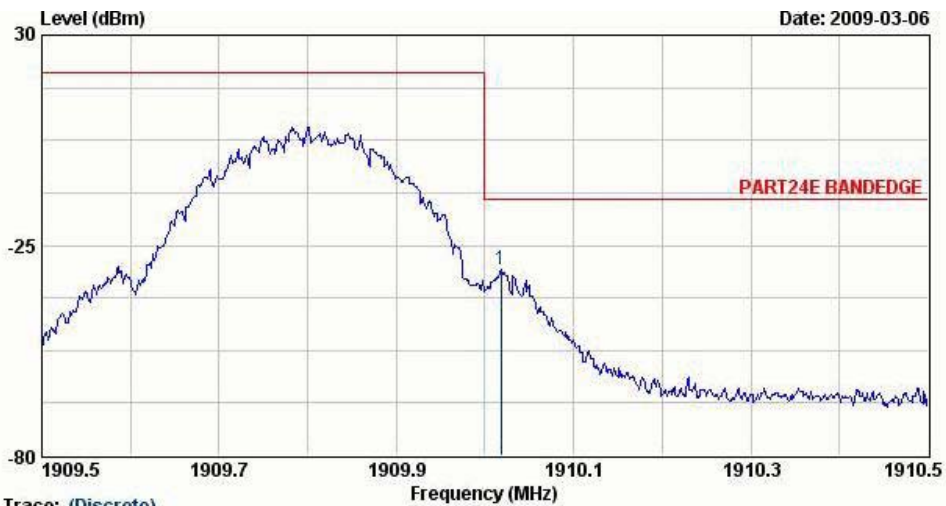

Trace: (Discrete)
 Site : 03CH07-HY
 Condition : PART24E BANDEDGE HF-EIRP(080306) HORIZONTAL
 Project : FG 921118

	Freq	Level	Over	Limit	Read		
	MHz	dBm	Limit	Line	Level	Factor	Remark
			dB	dBm	dBm	dB	
1	1910.02	-31.25	-18.25	-13.00	-40.38	9.14	Peak



Band :	GSM1900	Temperature :	24~26°C
Test Mode :	GPRS Link	Relative Humidity :	41~43%
Test Engineer :	Elvis Chen	Polarization :	Vertical
Remark :	Higher Band Edge Plot on Channel 810		

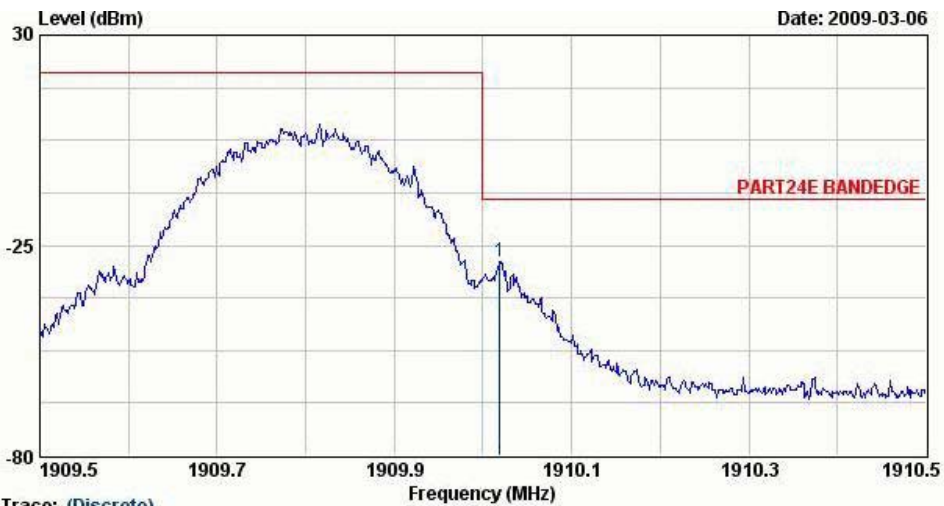

Trace: (Discrete)
 Site : 03CH07-HY
 Condition : PART24E BANDEDGE HF-EIRP(080306) VERTICAL
 Project : FG 921118

	Freq	Level	Over	Limit	Read	Factor	Remark
	MHz	dBm	dB	dBm	dBm	dB	
1 @	1910.02	-29.22	-16.22	-13.00	-40.69	11.47	Peak



Band :	GSM1900	Temperature :	24~26°C
Test Mode :	EDGE Link	Relative Humidity :	41~43%
Test Engineer :	Elvis Chen	Polarization :	Horizontal
Remark :	Lower Band Edge Plot on Channel 512		

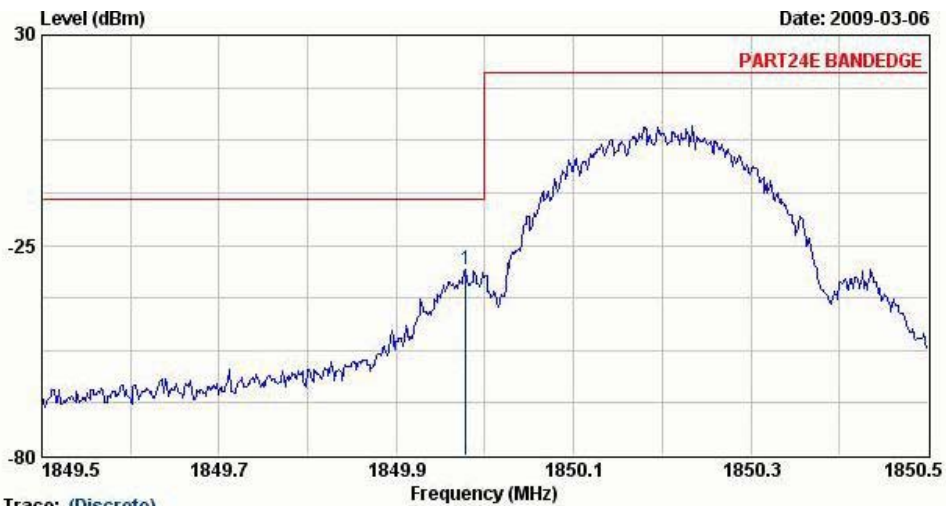

Trace: (Discrete)
 Site : 03CH07-HY
 Condition : PART24E BANDEDGE HF-EIRP(080306) HORIZONTAL
 Project : FG 921118

	Freq	Level	Over	Limit	Read		
	MHz	dBm	Limit	Line	Level	Factor	Remark
			dB	dBm	dBm	dB	
1 @	1849.98	-31.47	-18.47	-13.00	-40.26	8.79	Peak



Band :	GSM1900	Temperature :	24~26°C
Test Mode :	EDGE Link	Relative Humidity :	41~43%
Test Engineer :	Elvis Chen	Polarization :	Vertical
Remark :	Lower Band Edge Plot on Channel 512		

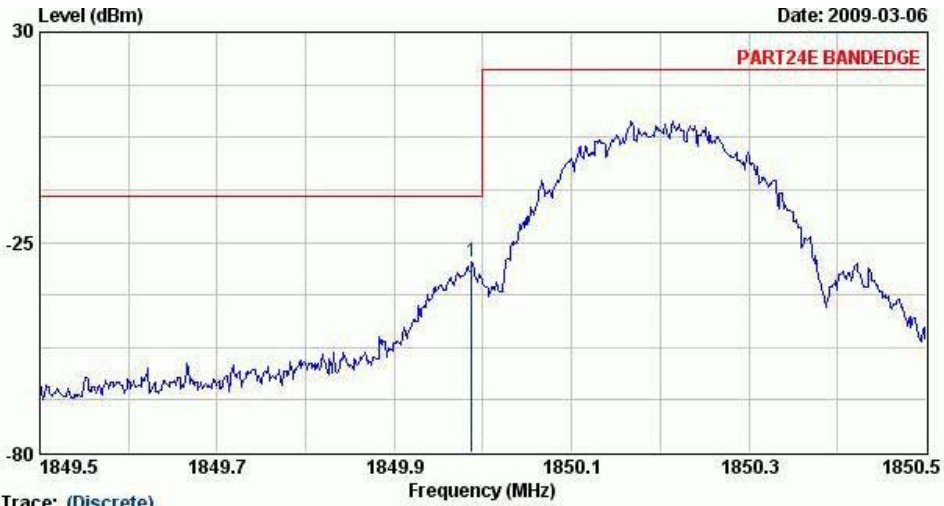

Trace: (Discrete)
 Site : 03CH07-HY
 Condition : PART24E BANDEDGE HF-EIRP(080306) VERTICAL
 Project : FG 921118

	Freq	Level	Over	Limit	Read	Factor	Remark
	MHz	dBm	dB	dBm	dBm	dB	
1 @	1849.99	-30.24	-17.24	-13.00	-41.33	11.09	Peak



Band :	GSM1900	Temperature :	24~26°C
Test Mode :	EDGE Link	Relative Humidity :	41~43%
Test Engineer :	Elvis Chen	Polarization :	Horizontal
Remark :	Higher Band Edge Plot on Channel 810		

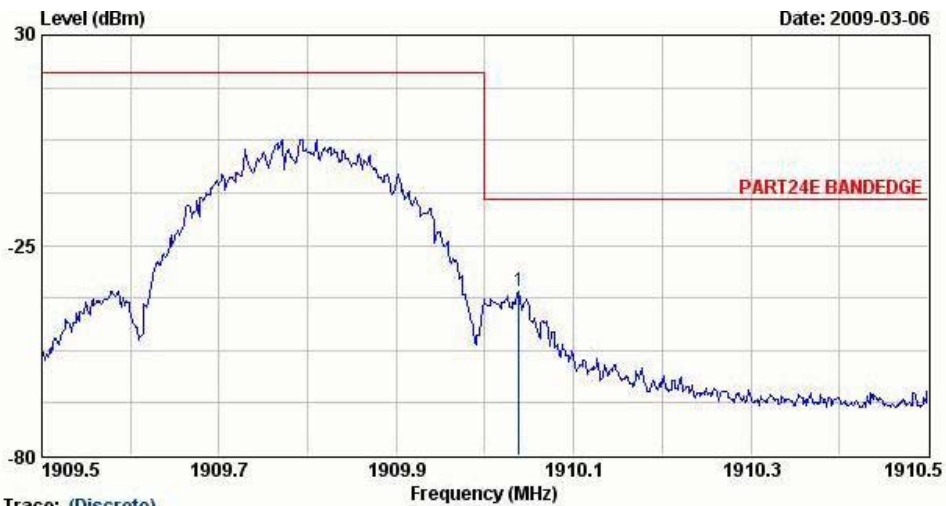

Trace: (Discrete)
 Site : 03CH07-HY
 Condition : PART24E BANDEDGE HF-EIRP(080306) HORIZONTAL
 Project : FG 921118

	Freq	Level	Over Limit	Limit Line	Read Level	Factor	Remark
	MHz	dBm	dB	dBm	dBm	dB	
1	1910.04	-37.17	-24.17	-13.00	-46.31	9.14	Peak



Band :	GSM1900	Temperature :	24~26°C
Test Mode :	EDGE Link	Relative Humidity :	41~43%
Test Engineer :	Elvis Chen	Polarization :	Vertical
Remark :	Higher Band Edge Plot on Channel 810		

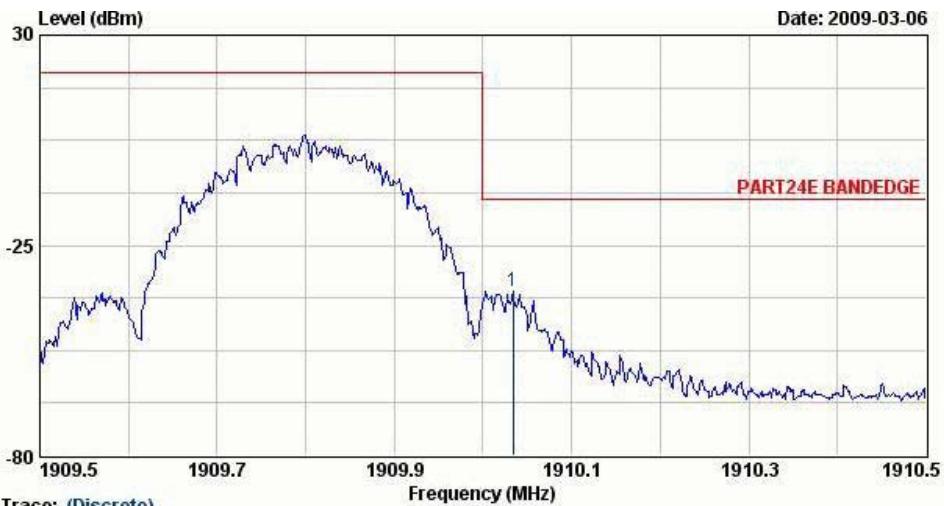

Trace: (Discrete)
 Site : 03CH07-HY
 Condition : PART24E BANDEDGE HF-EIRP(080306) VERTICAL
 Project : FG 921118

	Freq	Level	Over Limit	Limit Line	Read Level	Factor	Remark
	MHz	dBm	dB	dBm	dBm	dB	
1 @	1910.03	-37.05	-24.05	-13.00	-48.52	11.47	Peak



Band :	WCDMA Band V	Temperature :	24~26°C
Test Mode :	WCDMA Link	Relative Humidity :	41~43%
Test Engineer :	Elvis Chen	Polarization :	Horizontal
Remark :	Lower Band Edge Plot on Channel 4132		

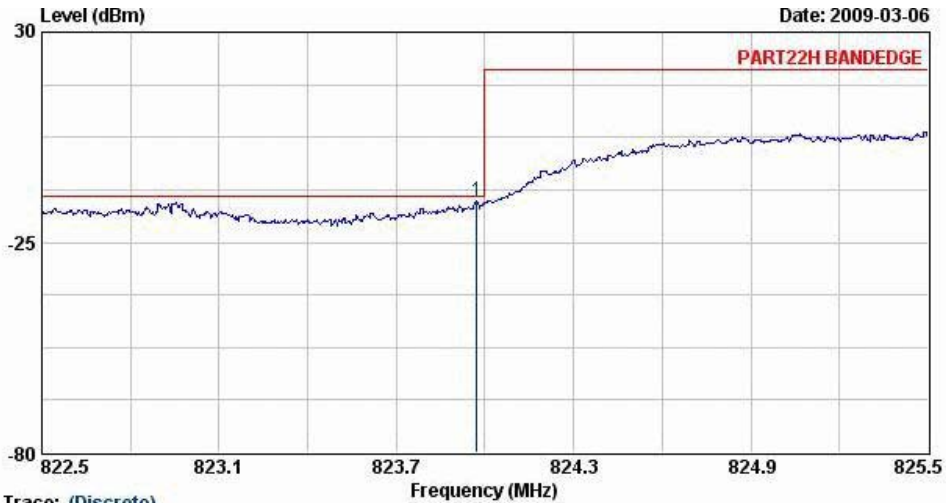

Trace: (Discrete)
 Site : 03CH07-HY
 Condition : PART22H BANDEDGE LF-EIRP(080719)-H HORIZONTAL
 Project : FG 921118

	Freq	Level	Over Limit	Limit Line	Read Level	Factor	Remark
	MHz	dBm	dB	dBm	dBm	dB	
1 @	823.97	-14.05	-1.05	-13.00	-17.36	3.31	Peak



Band :	WCDMA Band V	Temperature :	24~26°C
Test Mode :	WCDMA Link	Relative Humidity :	41~43%
Test Engineer :	Elvis Chen	Polarization :	Vertical
Remark :	Lower Band Edge Plot on Channel 4132		

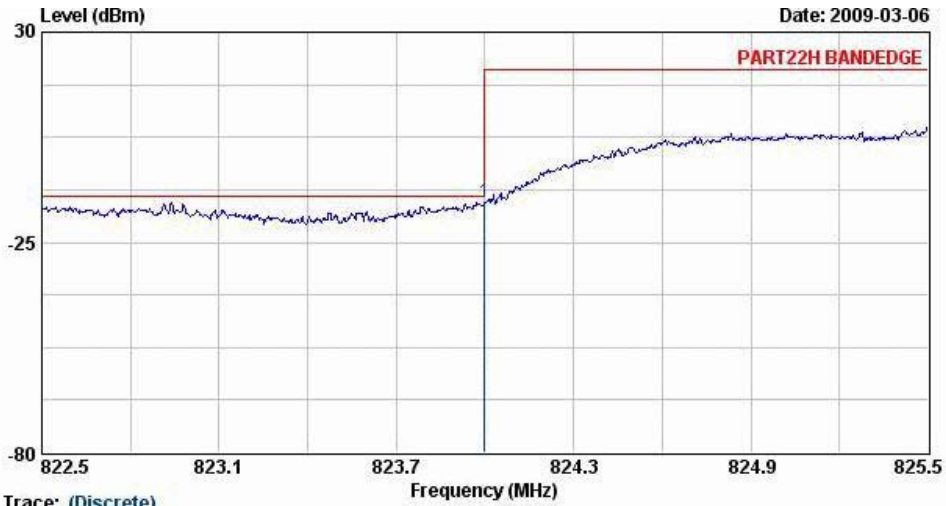

Trace: (Discrete)
 Site : 03CH07-HY
 Condition : PART22H BANDEGE LF-EIRP(080719)-V VERTICAL
 Project : FG 921118

	Freq	Level	Over Limit	Limit Line	Read Level	Factor	Remark
	MHz	dBm	dB	dBm	dBm	dB	
1	824.00	-14.68	-1.68	-13.00	-18.98	4.30	Peak



Band :	WCDMA Band V	Temperature :	24~26°C
Test Mode :	WCDMA Link	Relative Humidity :	41~43%
Test Engineer :	Elvis Chen	Polarization :	Horizontal
Remark :	Higher Band Edge Plot on Channel 4233		

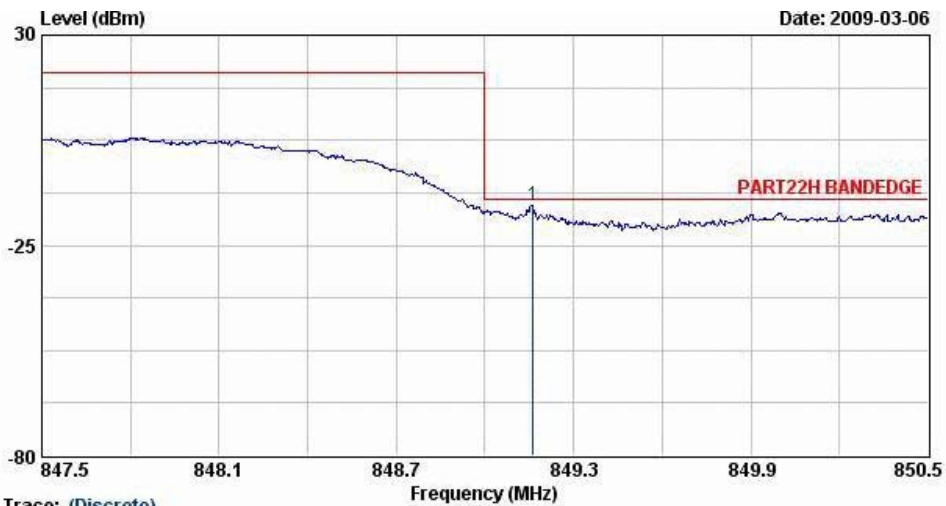

Trace: (Discrete)
 Site : 03CH07-HY
 Condition : PART22H BANDEGE LF-EIRP(080719)-H HORIZONTAL
 Project : FG 921118

	Freq	Level	Over	Limit	Read		
	MHz	dBm	Limit	Line	Level	Factor	Remark
			dB	dBm	dBm	dB	
1	849.16	-14.70	-1.70	-13.00	-18.24	3.54	Peak



Band :	WCDMA Band V	Temperature :	24~26°C
Test Mode :	WCDMA Link	Relative Humidity :	41~43%
Test Engineer :	Elvis Chen	Polarization :	Vertical
Remark :	Higher Band Edge Plot on Channel 4233		

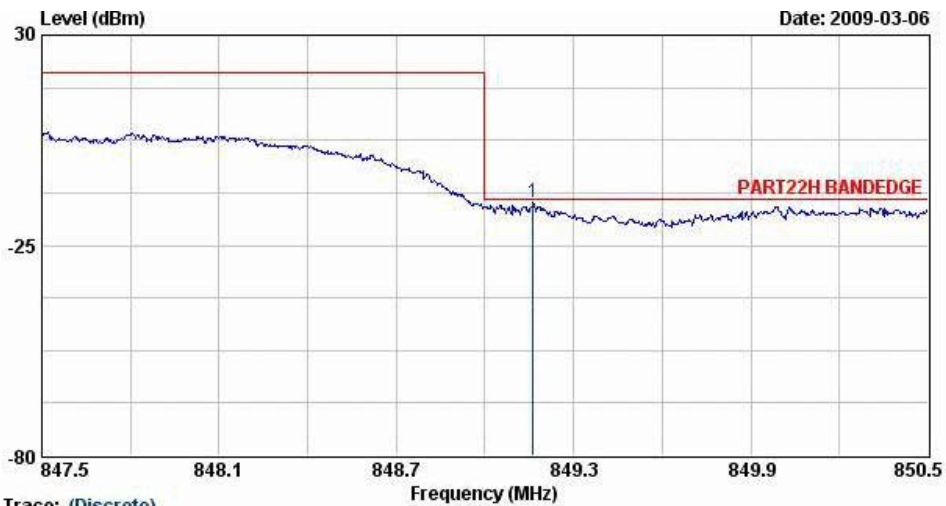

Trace: (Discrete)
 Site : 03CH07-HY
 Condition : PART22H BANDEDGE LF-EIRP(080719)-V VERTICAL
 Project : FG 921118

	Freq	Level	Over	Limit	Read		
	MHz	dBm	Limit	Line	Level	Factor	Remark
			dB	dBm	dBm	dB	
1 @	849.16	-13.92	-0.92	-13.00	-18.39	4.46	Peak



Band :	WCDMA Band II	Temperature :	24~26°C
Test Mode :	WCDMA Link	Relative Humidity :	41~43%
Test Engineer :	Elvis Chen	Polarization :	Horizontal
Remark :	Lower Band Edge Plot on Channel 9262		

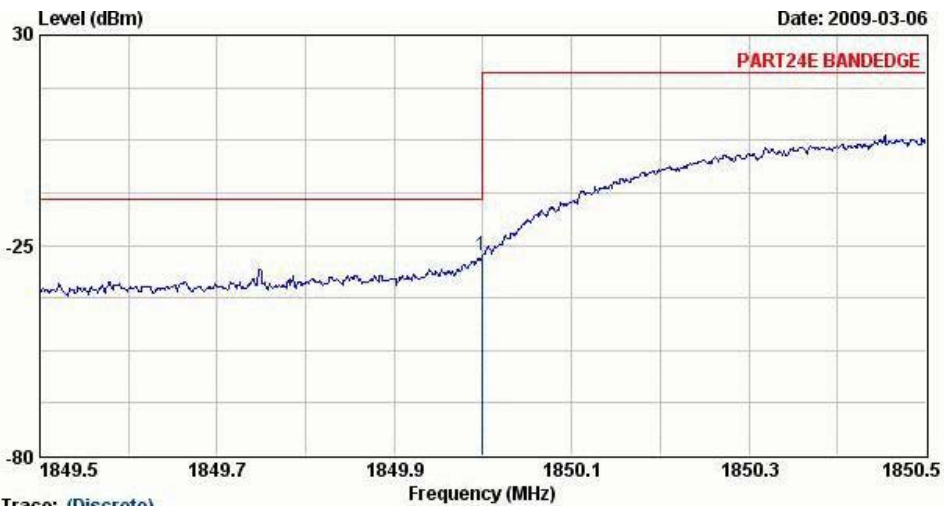

Trace: (Discrete)
 Site : 03CH07-HY
 Condition : PART24E BANDEDGE HF-EIRP(080306) HORIZONTAL
 Project : FG 921118

	Freq	Level	Over Limit	Limit Line	Read Level	Factor	Remark
	MHz	dBm	dB	dBm	dBm	dB	
1	1850.00	-27.64	-14.64	-13.00	-36.43	8.79	Peak



Band :	WCDMA Band II	Temperature :	24~26°C
Test Mode :	WCDMA Link	Relative Humidity :	41~43%
Test Engineer :	Elvis Chen	Polarization :	Vertical
Remark :	Lower Band Edge Plot on Channel 9262		

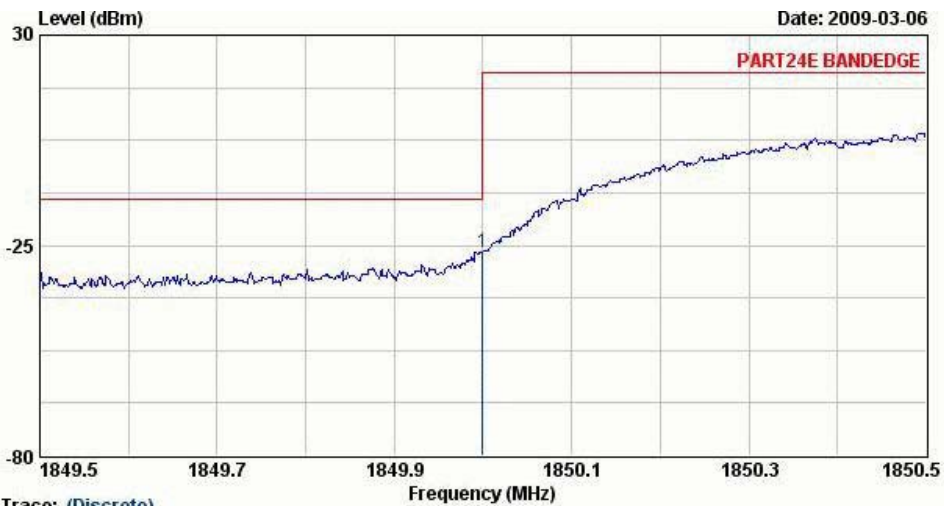

Trace: (Discrete)
 Site : 03CH07-HY
 Condition : PART24E BANDEDGE HF-EIRP(080306) VERTICAL
 Project : FG 921118

	Freq	Level	Over Limit	Limit Line	Read Level	Factor	Remark
	MHz	dBm	dB	dBm	dBm	dB	
1 @	1850.00	-26.68	-13.68	-13.00	-37.77	11.09	Peak



Band :	WCDMA Band II	Temperature :	24~26°C
Test Mode :	WCDMA Link	Relative Humidity :	41~43%
Test Engineer :	Elvis Chen	Polarization :	Horizontal
Remark :	Higher Band Edge Plot on Channel 9538		

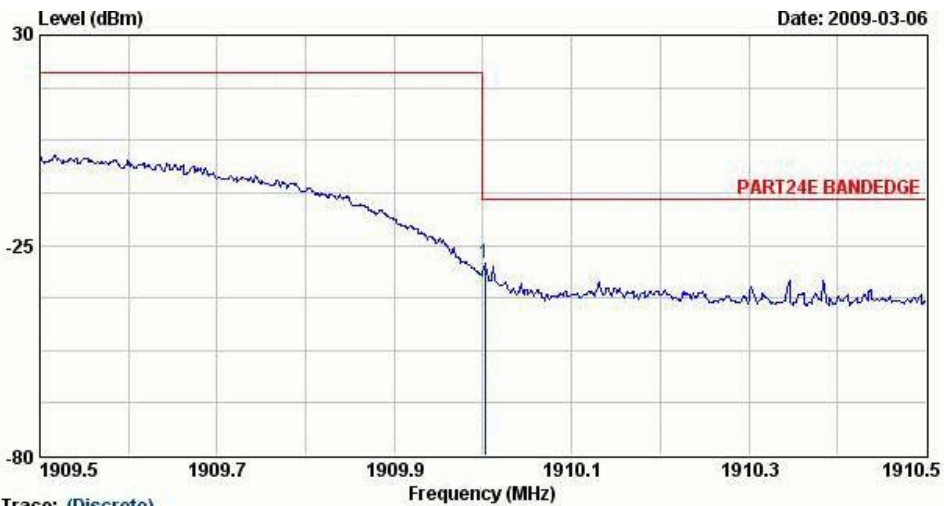

Trace: (Discrete)
 Site : 03CH07-HY
 Condition : PART24E BANDEDGE HF-EIRP(080306) HORIZONTAL
 Project : FG 921118

	Freq	Level	Over Limit	Limit Line	Read Level	Factor	Remark
	MHz	dBm	dB	dBm	dBm	dB	
1	1910.00	-29.87	-16.87	-13.00	-39.00	9.14	Peak



Band :	WCDMA Band II	Temperature :	24~26°C
Test Mode :	WCDMA Link	Relative Humidity :	41~43%
Test Engineer :	Elvis Chen	Polarization :	Vertical
Remark :	Higher Band Edge Plot on Channel 9538		

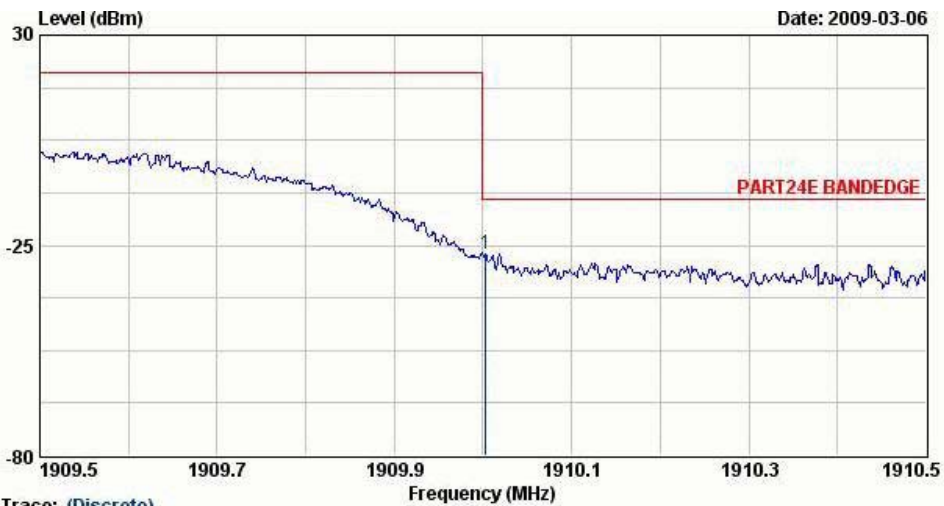

Trace: (Discrete)
 Site : 03CH07-HY
 Condition : PART24E BANDEDGE HF-EIRP(080306) VERTICAL
 Project : FG 921118

	Freq	Level	Over Limit	Limit Line	Read Level	Factor	Remark
	MHz	dBm	dB	dBm	dBm	dB	
1 @	1910.00	-27.14	-14.14	-13.00	-38.61	11.47	Peak

3.3 Effective Radiated Power and Effective Isotropic Radiated Power Measurement

3.3.1 Description of the ERP/EIRP Measurement

ERP/EIRP is measured by substitution method according to ANSI / TIA / EIA-603-C-2004. The ERP of mobile transmitters must not exceed 7 Watts and the EIRP of mobile transmitters are limited to 2 Watts.

3.3.2 Measuring Instruments

See list of measuring instruments of this test report.

3.3.3 Test Procedures

1. The EUT was placed on a turntable with 1.0 meter height in a fully anechoic chamber.
2. The EUT was set at 1.2 meters from the receiving antenna, which was mounted on the antenna tower.
3. The table was rotated 360 degrees to determine the position of the highest radiated power.
4. The height of the receiving antenna is adjusted to look for the maximum ERP/EIRP.
5. Taking the record of maximum ERP/EIRP.
6. A dipole antenna was substituted in place of the EUT and was driven by a signal generator.
7. The conducted power at the terminal of the dipole antenna is measured.
8. Repeat step 3 to step 5 to get the maximum ERP/EIRP of the substitution antenna.
9. $ERP/EIRP = P_s + E_t - E_s + G_s = P_s + R_t - R_s + G_s$
Ps (dBm) : Input power to substitution antenna.
Gs (dBi or dBd) : Substitution antenna Gain.
 $E_t = R_t + AF$
 $E_s = R_s + AF$
AF (dB/m) : Receive antenna factor
Rt : The highest received signal in spectrum analyzer for EUT.
Rs : The highest received signal in spectrum analyzer for substitution antenna.

3.3.4 Test Setup

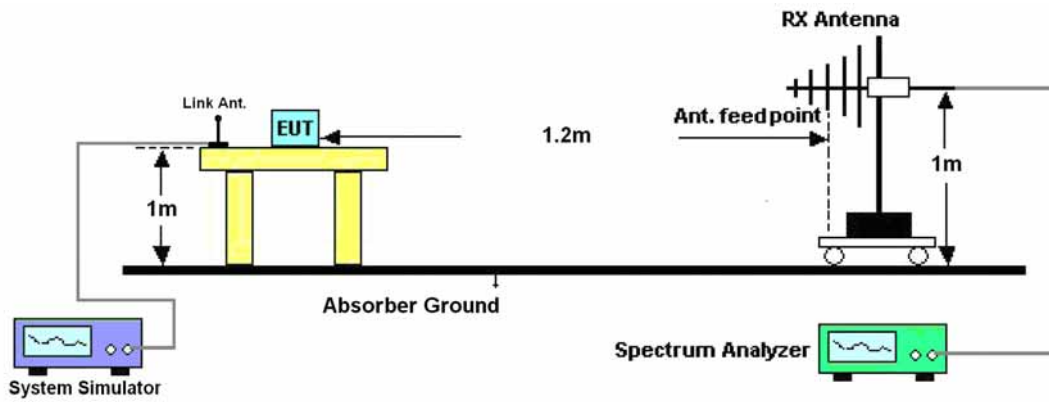



3.3.5 Test Result of ERP

GSM850 (GPRS 8) Radiated Power ERP						
Horizontal Polarization						
Frequency (MHz)	Rt (dBm)	Rs (dBm)	Ps (dBm)	Gs (dBd)	ERP (dBm)	ERP (W)
824.20	-21.77	-48.12	0.00	-1.08	25.27	0.34
836.40	-24.41	-48.28	0.00	-0.93	22.94	0.20
848.80	-24.71	-48.35	0.00	-0.76	22.88	0.19
Vertical Polarization						
Frequency (MHz)	Rt (dBm)	Rs (dBm)	Ps (dBm)	Gs (dBd)	ERP (dBm)	ERP (W)
824.20	-17.85	-47.97	0.00	-1.08	29.04	0.80
836.40	-22.24	-48.01	0.00	-0.93	24.84	0.30
848.80	-23.99	-48.05	0.00	-0.76	23.30	0.21

GSM850 (EDGE 8) Radiated Power ERP						
Horizontal Polarization						
Frequency (MHz)	Rt (dBm)	Rs (dBm)	Ps (dBm)	Gs (dBd)	ERP (dBm)	ERP (W)
824.20	-26.91	-48.12	0.00	-1.08	20.13	0.10
836.40	-27.64	-48.28	0.00	-0.93	19.71	0.09
848.80	-29.90	-48.35	0.00	-0.76	17.69	0.06
Vertical Polarization						
Frequency (MHz)	Rt (dBm)	Rs (dBm)	Ps (dBm)	Gs (dBd)	ERP (dBm)	ERP (W)
824.20	-23.08	-47.97	0.00	-1.08	23.81	0.24
836.40	-26.36	-48.01	0.00	-0.93	20.72	0.12
848.80	-28.48	-48.05	0.00	-0.76	18.81	0.08



WCDMA Band V Radiated Power ERP						
Horizontal Polarization						
Frequency (MHz)	Rt (dBm)	Rs (dBm)	Ps (dBm)	Gs (dBd)	ERP (dBm)	ERP (W)
826.40	-30.12	-48.12	0.00	-1.08	16.92	0.05
836.40	-30.04	-48.28	0.00	-0.93	17.31	0.05
846.60	-29.50	-48.35	0.00	-0.76	18.09	0.06
Vertical Polarization						
Frequency (MHz)	Rt (dBm)	Rs (dBm)	Ps (dBm)	Gs (dBd)	ERP (dBm)	ERP (W)
826.40	-26.53	-47.97	0.00	-1.08	20.36	0.11
836.40	-28.50	-48.01	0.00	-0.93	18.58	0.07
846.60	-29.28	-48.05	0.00	-0.76	18.01	0.06



3.3.6 Test Result of EIRP

GSM1900 (GPRS 8) Radiated Power EIRP						
Horizontal Polarization						
Frequency (MHz)	Rt (dBm)	Rs (dBm)	Ps (dBm)	Gs (dBi)	EIRP (dBm)	EIRP (W)
1850.20	-34.30	-51.88	0.00	1.96	19.54	0.09
1880.00	-37.11	-52.99	0.00	2.00	17.88	0.06
1909.80	-40.81	-54.28	0.00	1.98	15.45	0.04
Vertical Polarization						
Frequency (MHz)	Rt (dBm)	Rs (dBm)	Ps (dBm)	Gs (dBi)	EIRP (dBm)	EIRP (W)
1850.20	-32.99	-52.13	0.00	1.96	21.10	0.13
1880.00	-34.92	-53.17	0.00	2.00	20.25	0.11
1909.80	-38.75	-54.13	0.00	1.98	17.36	0.05

GSM1900 (EDGE 8) Radiated Power EIRP						
Horizontal Polarization						
Frequency (MHz)	Rt (dBm)	Rs (dBm)	Ps (dBm)	Gs (dBi)	EIRP (dBm)	EIRP (W)
1850.20	-37.70	-51.88	0.00	1.96	16.14	0.04
1880.00	-40.33	-52.99	0.00	2.00	14.66	0.03
1909.80	-42.64	-54.28	0.00	1.98	13.62	0.02
Vertical Polarization						
Frequency (MHz)	Rt (dBm)	Rs (dBm)	Ps (dBm)	Gs (dBi)	EIRP (dBm)	EIRP (W)
1850.20	-36.71	-52.13	0.00	1.96	17.38	0.05
1880.00	-38.54	-53.17	0.00	2.00	16.63	0.05
1909.80	-42.22	-54.13	0.00	1.98	13.89	0.02



WCDMA Band II Radiated Power EIRP						
Horizontal Polarization						
Frequency (MHz)	Rt (dBm)	Rs (dBm)	Ps (dBm)	Gs (dBi)	EIRP (dBm)	EIRP (W)
1852.40	-38.10	-51.88	0.00	1.96	15.74	0.04
1880.00	-42.43	-52.99	0.00	2.00	12.56	0.02
1907.60	-45.22	-54.28	0.00	1.98	11.04	0.01
Vertical Polarization						
Frequency (MHz)	Rt (dBm)	Rs (dBm)	Ps (dBm)	Gs (dBi)	EIRP (dBm)	EIRP (W)
1852.40	-36.42	-52.13	0.00	1.96	17.67	0.06
1880.00	-39.74	-53.17	0.00	2.00	15.43	0.03
1907.60	-41.99	-54.13	0.00	1.98	14.12	0.03

3.4 Field Strength of Spurious Radiation Measurement

3.4.1 Description of Field Strength of Spurious Radiated Measurement

The radiated spurious emission was measured by substitution method according to ANSI / TIA / EIA-603-C-2004. The power of any emission outside of the authorized operating frequency ranges must be attenuated below the transmitter power (P) by a factor of at least $43 + 10 \log (P)$ dB. The spectrum is scanned from 30 MHz up to a frequency including its 10th harmonic.

3.4.2 Measuring Instruments

See list of measuring instruments of this test report.

3.4.3 Test Procedures

1. The EUT was placed on a rotatable wooden table with 0.8 meter about ground.
2. The EUT was set 3 meters from the receiving antenna, which was mounted on the antenna tower.
3. The table was rotated 360 degrees to determine the position of the highest spurious emission.
4. The height of the receiving antenna is varied between one meter and four meters to search the maximum spurious emission for both horizontal and vertical polarizations.
5. Taking the record of maximum spurious emission.
6. A horn antenna was substituted in place of the EUT and was driven by a signal generator.
7. Tune the output power of signal generator to the same emission level with EUT maximum spurious emission.
8. Taking the record of output power at antenna port.
9. Repeat step 7 to step 8 for another polarization.
10. Emission level (dBm) = output power + substitution Gain.

3.4.4 Test Setup

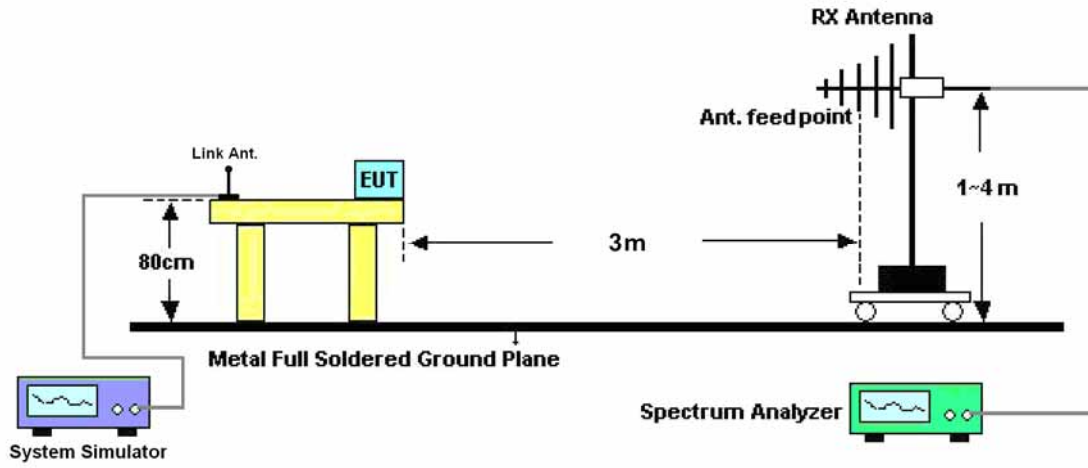



3.4.5 Test Result of Field Strength of Spurious Radiated

Band :	GSM850	Temperature :	24~26°C
Test Mode :	GPRS Link	Relative Humidity :	41~43%
Test Engineer :	Elvis Chen	Polarization :	Horizontal
Remark :	Spurious emissions within 30-1000MHz were found more than 20dB below limit line.		

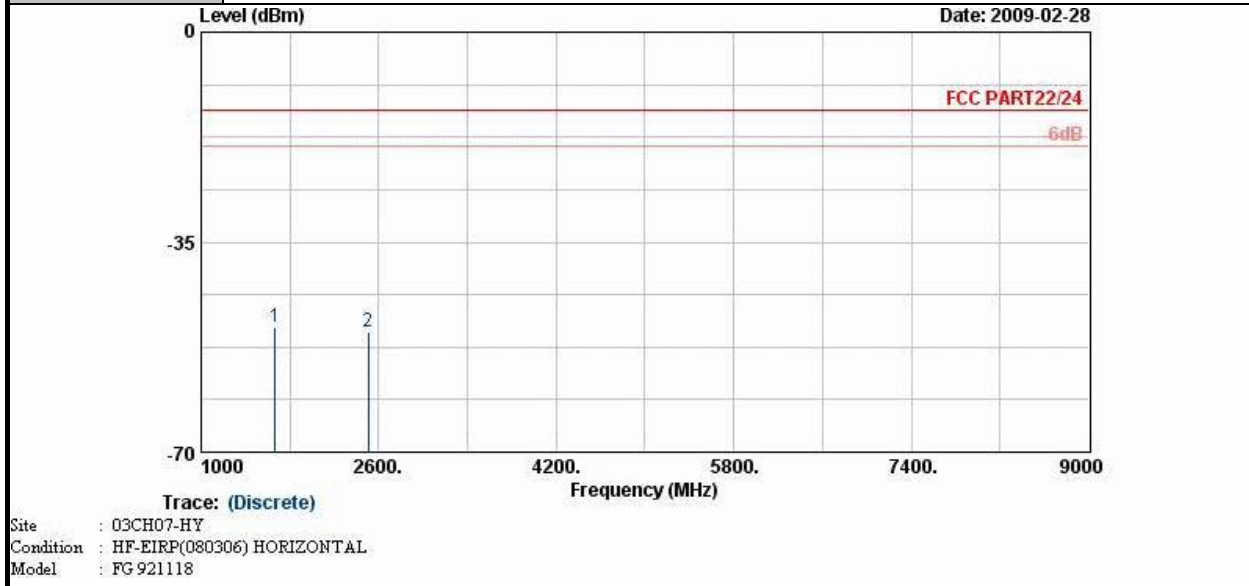

Frequency (MHz)	ERP (dBm)	Limit (dBm)	Over Limit (dB)	SPA Reading (dBm)	S.G. Power (dBm)	TX Cable loss (dB)	TX Antenna Gain (dBi)	Polarization (H/V)	Result
1669	-49.29	-13	-36.29	-55.80	-48.30	3.39	4.55	H	Pass
2509	-49.85	-13	-36.85	-56.47	-49.91	3.71	5.92	H	Pass



Band :	GSM850	Temperature :	24~26°C
Test Mode :	GPRS Link	Relative Humidity :	41~43%
Test Engineer :	Elvis Chen	Polarization :	Vertical
Remark :	Spurious emissions within 30-1000MHz were found more than 20dB below limit line.		

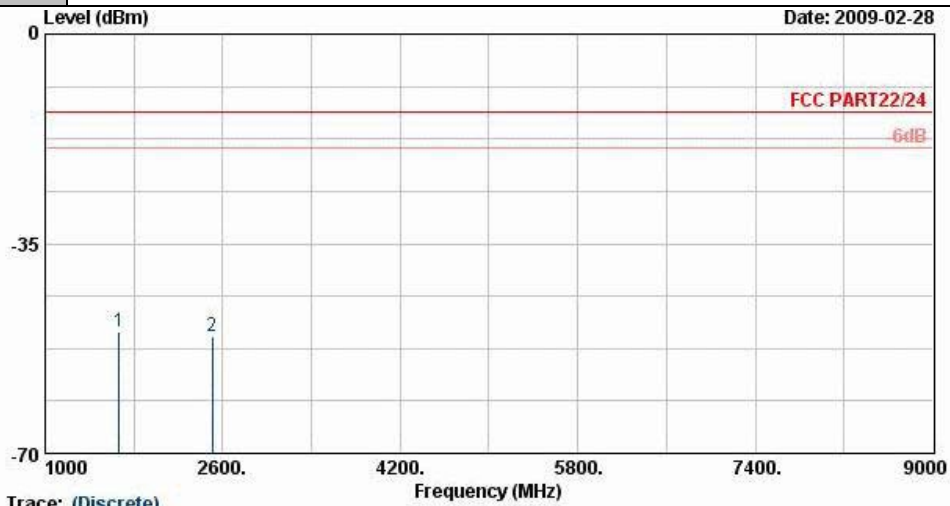

Site : 03CH07-HY
 Condition : HF-EIRP(080306) VERTICAL
 Model : FG 921118

Frequency (MHz)	ERP (dBm)	Limit (dBm)	Over Limit (dB)	SPA Reading (dBm)	S.G. Power (dBm)	TX Cable loss (dB)	TX Antenna Gain (dBi)	Polarization (H/V)	Result
1669	-49.65	-13	-36.65	-57.33	-48.27	3.39	4.16	V	Pass
2509	-50.38	-13	-37.38	-59.22	-50.24	3.71	5.72	V	Pass



Band :	GSM850	Temperature :	24~26°C
Test Mode :	EDGE Link	Relative Humidity :	41~43%
Test Engineer :	Elvis Chen	Polarization :	Horizontal
Remark :	Spurious emissions within 30-1000MHz were found more than 20dB below limit line.		

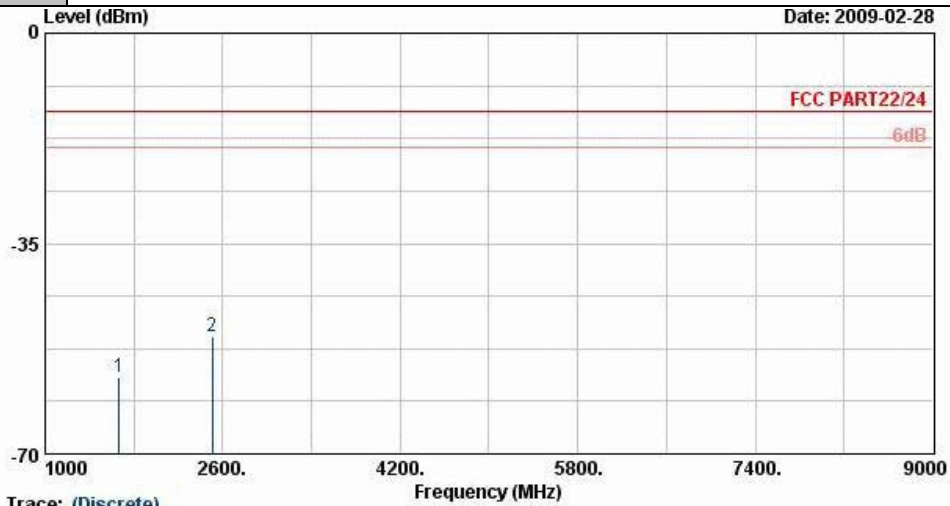

Site : 03CH07-HY
 Condition : HF-EIRP(080306) HORIZONTAL
 Model : FG 921118

Frequency (MHz)	ERP (dBm)	Limit (dBm)	Over Limit (dB)	SPA Reading (dBm)	S.G. Power (dBm)	TX Cable loss (dB)	TX Antenna Gain (dBi)	Polarization (H/V)	Result
1669	-57.32	-13	-44.32	-60.46	-56.33	3.39	4.55	H	Pass
2509	-50.54	-13	-37.54	-60.68	-50.60	3.71	5.92	H	Pass



Band :	GSM850	Temperature :	24~26°C
Test Mode :	EDGE Link	Relative Humidity :	41~43%
Test Engineer :	Elvis Chen	Polarization :	Vertical
Remark :	Spurious emissions within 30-1000MHz were found more than 20dB below limit line.		

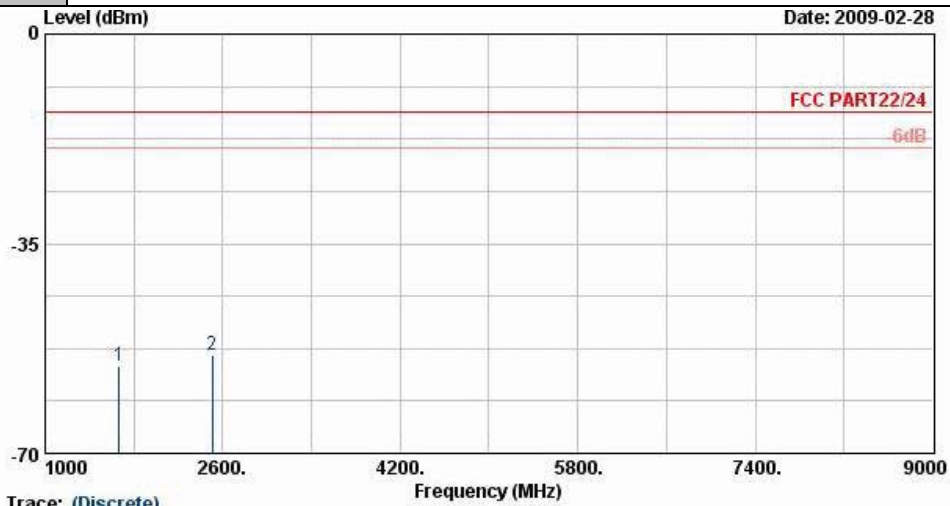

Site : 03CH07-HY
 Condition : HF-EIRP(080306) VERTICAL
 Model : FG 921118

Frequency (MHz)	ERP (dBm)	Limit (dBm)	Over Limit (dB)	SPA Reading (dBm)	S.G. Power (dBm)	TX Cable loss (dB)	TX Antenna Gain (dBi)	Polarization (H/V)	Result
1669	-55.54	-13	-42.54	-61.02	-54.16	3.39	4.16	V	Pass
2509	-53.52	-13	-40.52	-64.11	-53.38	3.71	5.72	V	Pass



Band :	GSM1900	Temperature :	24~26°C
Test Mode :	GPRS Link	Relative Humidity :	41~43%
Test Engineer :	Elvis Chen	Polarization :	Horizontal
Remark :	Spurious emissions within 30-1000MHz were found more than 20dB below limit line.		

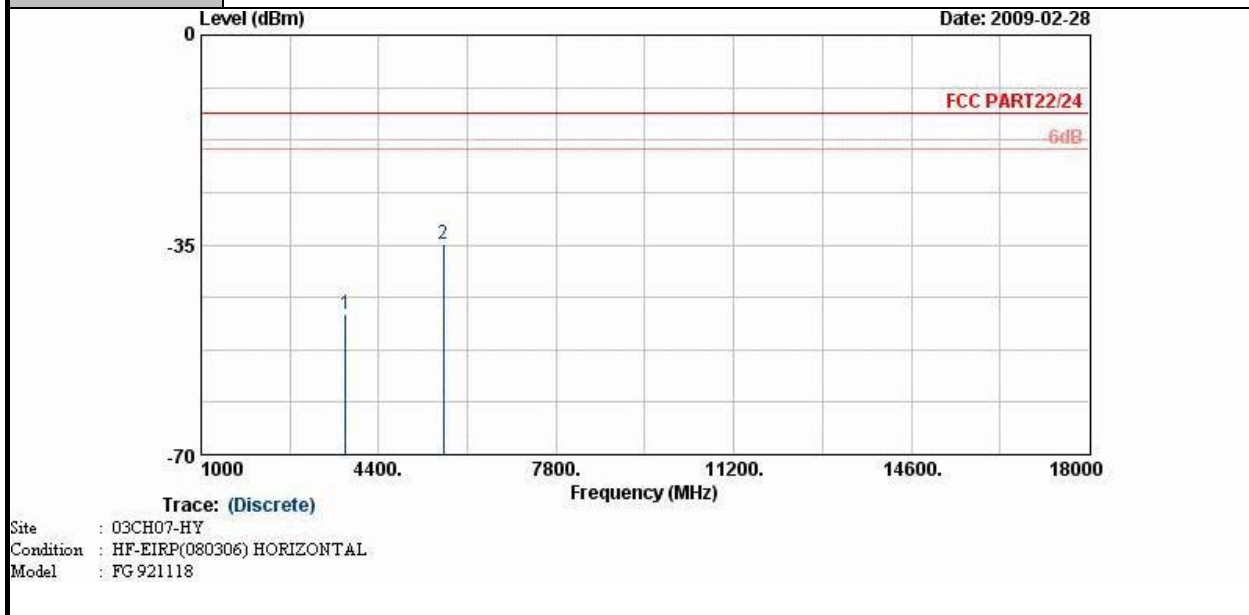

Frequency (MHz)	EIRP (dBm)	Limit (dBm)	Over Limit (dB)	SPA Reading (dBm)	S.G. Power (dBm)	TX Cable loss (dB)	TX Antenna Gain (dBi)	Polarization (H/V)	Result
3760	-46.61	-13	-33.61	-60.51	-49.98	4.03	7.40	H	Pass
5636	-34.85	-13	-21.85	-56.54	-39.79	3.87	8.81	H	Pass



Band :	GSM1900	Temperature :	24~26°C
Test Mode :	GPRS Link	Relative Humidity :	41~43%
Test Engineer :	Elvis Chen	Polarization :	Vertical
Remark :	Spurious emissions within 30-1000MHz were found more than 20dB below limit line.		

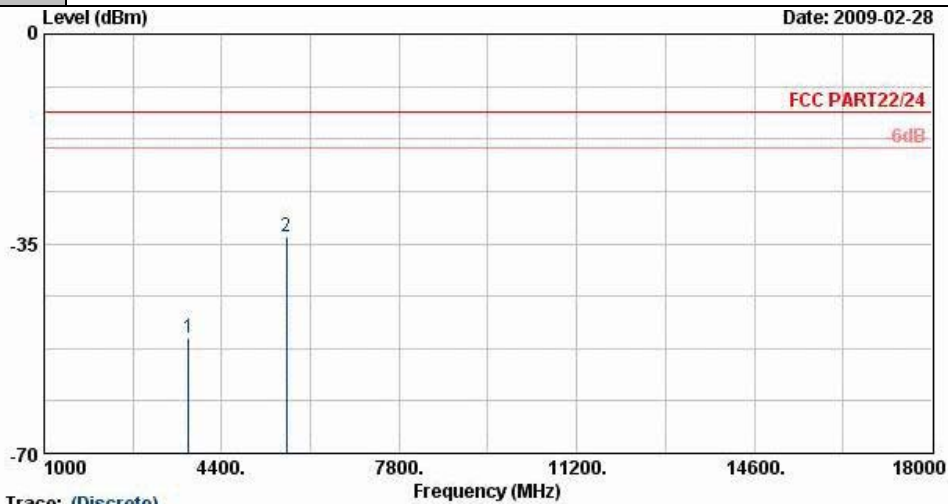

Trace: (Discrete)
 Site : 03CH07-HY
 Condition : HF-EIRP(080306) VERTICAL
 Model : FG 921118

Frequency (MHz)	EIRP (dBm)	Limit (dBm)	Over Limit (dB)	SPA Reading (dBm)	S.G. Power (dBm)	TX Cable loss (dB)	TX Antenna Gain (dBi)	Polarization (H/V)	Result
3760	-50.74	-13	-37.74	-64.67	-54.62	4.03	7.91	V	Pass
5636	-33.70	-13	-20.70	-56.39	-39.60	3.87	9.77	V	Pass



Band :	GSM1900	Temperature :	24~26°C
Test Mode :	EDGE Link	Relative Humidity :	41~43%
Test Engineer :	Elvis Chen	Polarization :	Horizontal
Remark :	Spurious emissions within 30-1000MHz were found more than 20dB below limit line.		

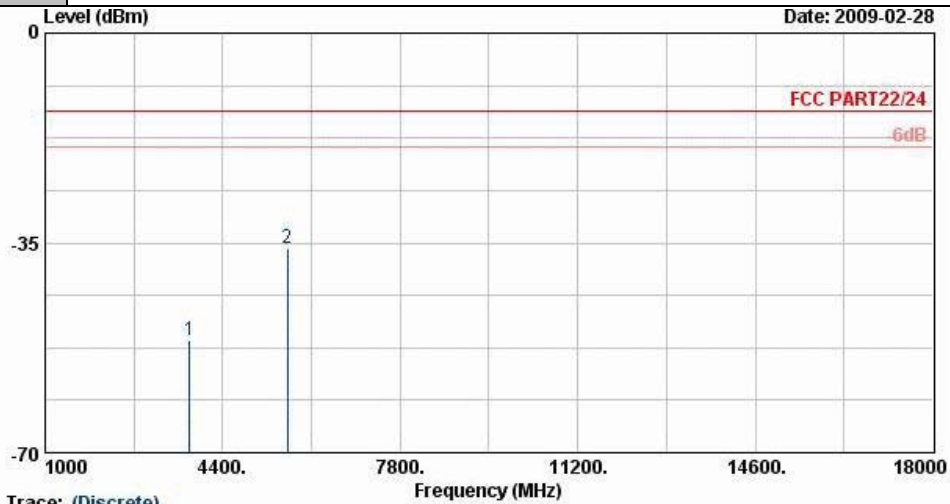

Site : 03CH07-HY
 Condition : HF-EIRP(080306) HORIZONTAL
 Model : FG 921118

Frequency (MHz)	EIRP (dBm)	Limit (dBm)	Over Limit (dB)	SPA Reading (dBm)	S.G. Power (dBm)	TX Cable loss (dB)	TX Antenna Gain (dBi)	Polarization (H/V)	Result
3760	-51.14	-13	-38.14	-62.72	-54.51	4.03	7.40	H	Pass
5636	-35.80	-13	-22.80	-57.26	-40.74	3.87	8.81	H	Pass



Band :	GSM1900	Temperature :	24~26°C
Test Mode :	EDGE Link	Relative Humidity :	41~43%
Test Engineer :	Elvis Chen	Polarization :	Vertical
Remark :	Spurious emissions within 30-1000MHz were found more than 20dB below limit line.		

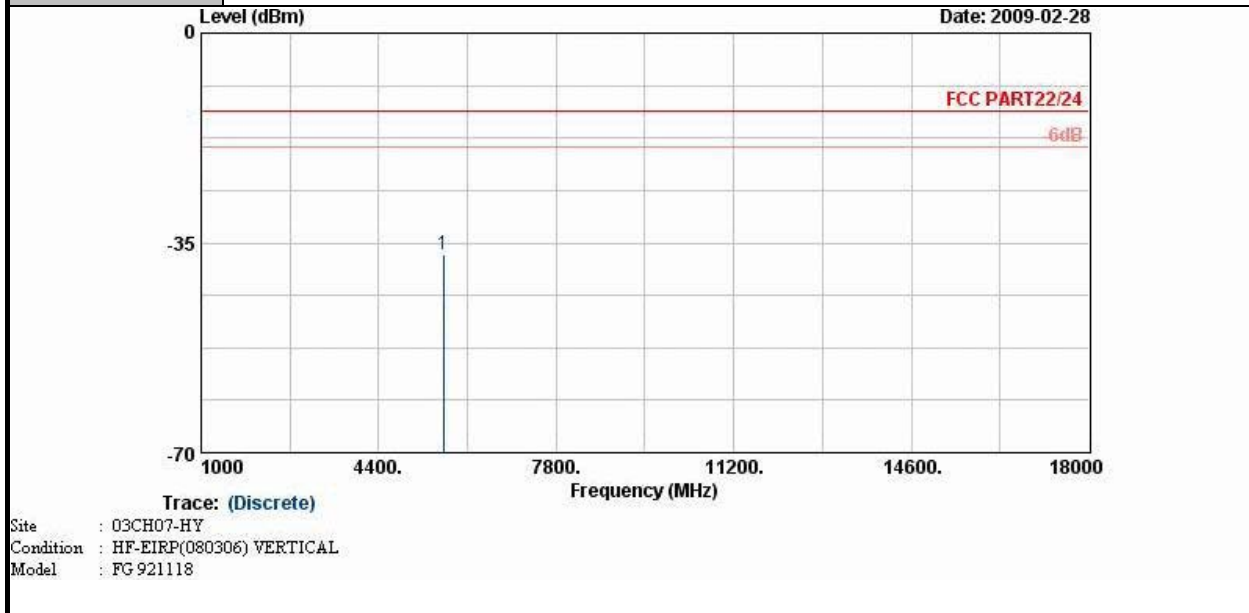

Frequency (MHz)	EIRP (dBm)	Limit (dBm)	Over Limit (dB)	SPA Reading (dBm)	S.G. Power (dBm)	TX Cable loss (dB)	TX Antenna Gain (dBi)	Polarization (H/V)	Result
5636	-37.01	-13	-24.01	-59.31	-42.91	3.87	9.77	V	Pass



Band :	WCDMA Band V	Temperature :	24~26°C
Test Mode :	WCDMA Link	Relative Humidity :	41~43%
Test Engineer :	Elvis Chen	Polarization :	Horizontal
Remark :	Spurious emissions within 30-1000MHz were found more than 20dB below limit line.		

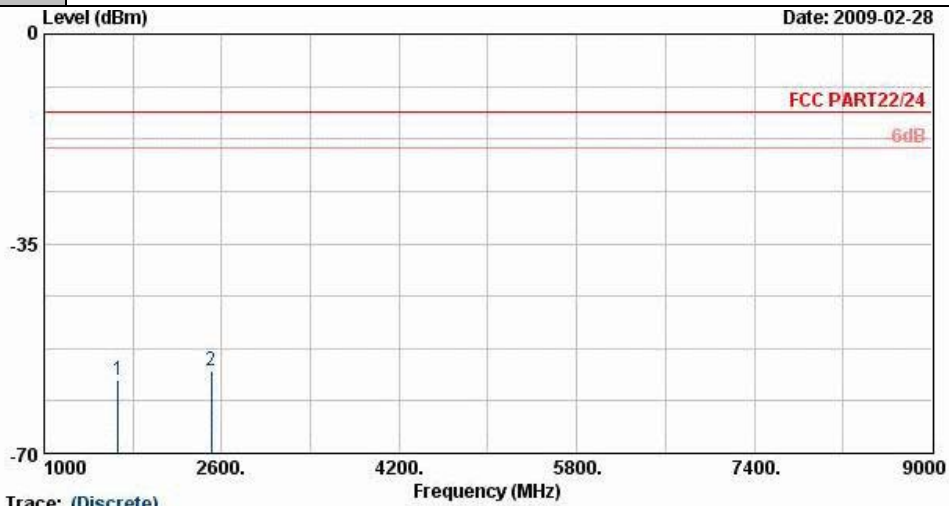

Trace: (Discrete)
 Site : 03CH07-HY
 Condition : FCC PART22/24 HF-EIRP(080306) HORIZONTAL
 Model : FG 921118

Frequency (MHz)	ERP (dBm)	Limit (dBm)	Over Limit (dB)	SPA Reading (dBm)	S.G. Power (dBm)	TX Cable loss (dB)	TX Antenna Gain (dBi)	Polarization (H/V)	Result
1669	-57.64	-13	-44.64	-61.10	-56.65	3.39	4.55	H	Pass
2509	-56.13	-13	-43.13	-66.27	-56.19	3.71	5.92	H	Pass



Band :	WCDMA Band V	Temperature :	24~26°C
Test Mode :	WCDMA Link	Relative Humidity :	41~43%
Test Engineer :	Elvis Chen	Polarization :	Vertical
Remark :	Spurious emissions within 30-1000MHz were found more than 20dB below limit line.		

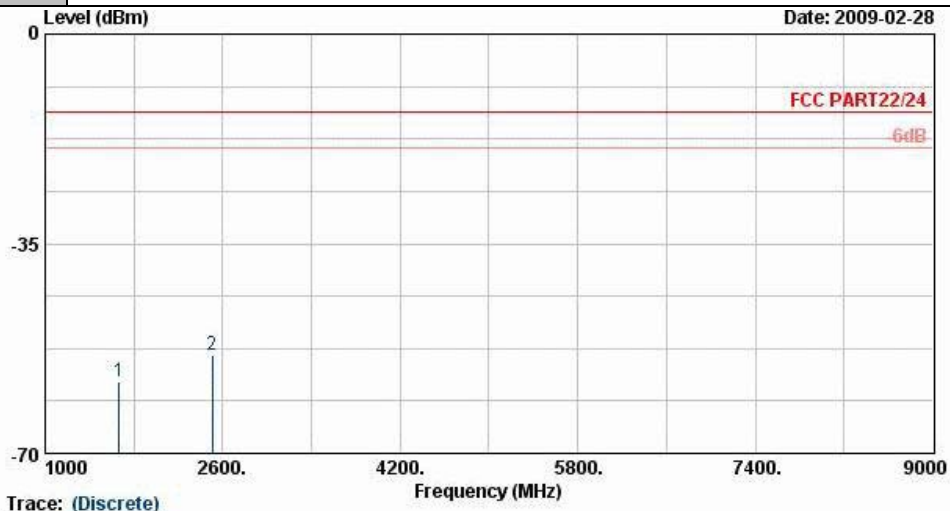

Site : 03CH07-HY
 Condition : FCC PART22/24 HF-EIRP(080306) VERTICAL
 Model : FG 921118

Frequency (MHz)	ERP (dBm)	Limit (dBm)	Over Limit (dB)	SPA Reading (dBm)	S.G. Power (dBm)	TX Cable loss (dB)	TX Antenna Gain (dBi)	Polarization (H/V)	Result
1669	-57.90	-13	-44.90	-62.12	-56.52	3.39	4.16	V	Pass
2509	-53.71	-13	-40.71	-64.30	-53.57	3.71	5.72	V	Pass



Band :	WCDMA Band II	Temperature :	24~26°C
Test Mode :	WCDMA Link	Relative Humidity :	41~43%
Test Engineer :	Elvis Chen	Polarization :	Horizontal
Remark :	Spurious emissions within 30-1000MHz were found more than 20dB below limit line.		

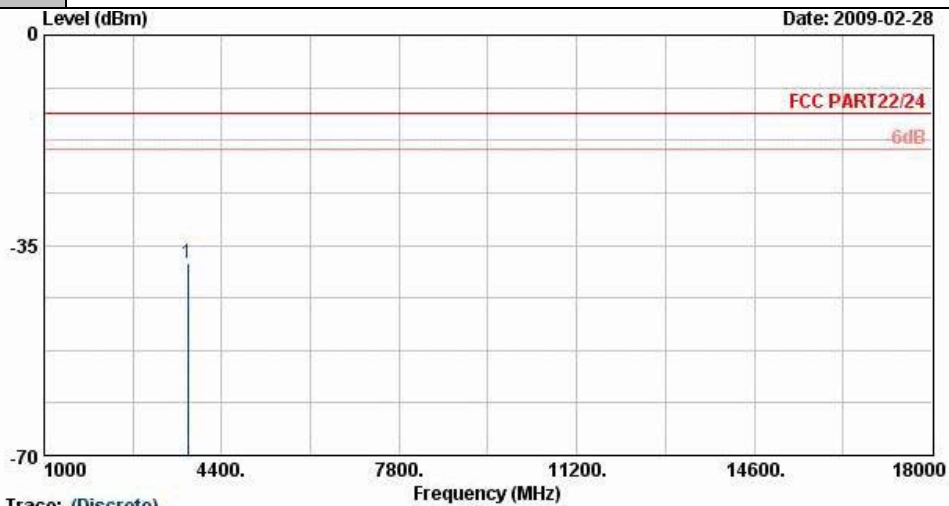

Site : 03CH07-HY
 Condition : FCC PART22/24 HF-EIRP(080306) HORIZONTAL
 Model : FG 921118

Frequency (MHz)	EIRP (dBm)	Limit (dBm)	Over Limit (dB)	SPA Reading (dBm)	S.G. Power (dBm)	TX Cable loss (dB)	TX Antenna Gain (dBi)	Polarization (H/V)	Result
3748	-37.93	-13	-24.93	-53.11	-41.30	4.03	7.40	H	Pass



Band :	WCDMA Band II	Temperature :	24~26°C
Test Mode :	WCDMA Link	Relative Humidity :	41~43%
Test Engineer :	Elvis Chen	Polarization :	Vertical
Remark :	Spurious emissions within 30-1000MHz were found more than 20dB below limit line.		

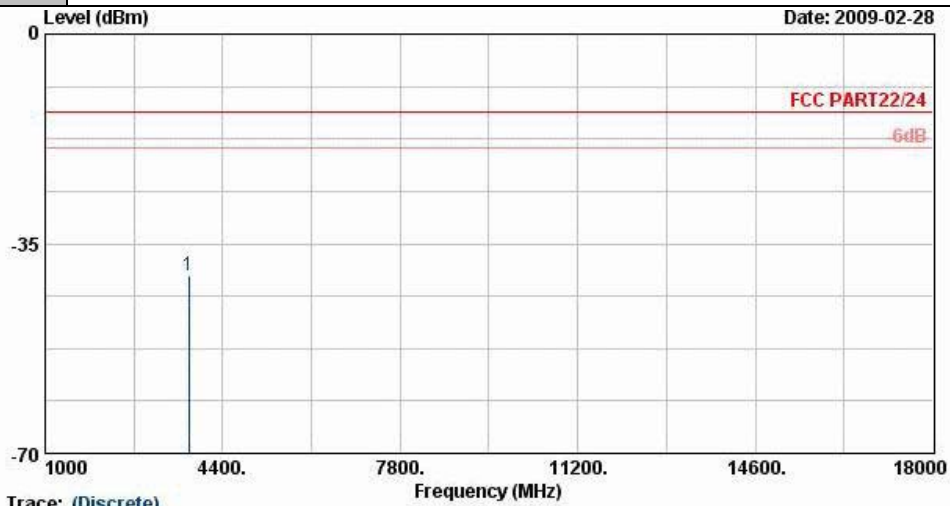

Trace: (Discrete)
 Site : 03CH07-HY
 Condition : FCC PART22/24 HF-EIRP(080306) VERTICAL
 Model : FG-921118

Frequency (MHz)	EIRP (dBm)	Limit (dBm)	Over Limit (dB)	SPA Reading (dBm)	S.G. Power (dBm)	TX Cable loss (dB)	TX Antenna Gain (dBi)	Polarization (H/V)	Result
3748	-40.45	-13	-27.45	-57.68	-44.33	4.03	7.91	V	Pass



Band :	GSM850	Temperature :	24~26°C
Test Mode :	GPRS Link + WLAN Link	Relative Humidity :	41~43%
Test Engineer :	Elvis Chen	Polarization :	Horizontal
Remark :	Spurious emissions within 30-1000MHz were found more than 20dB below limit line.		

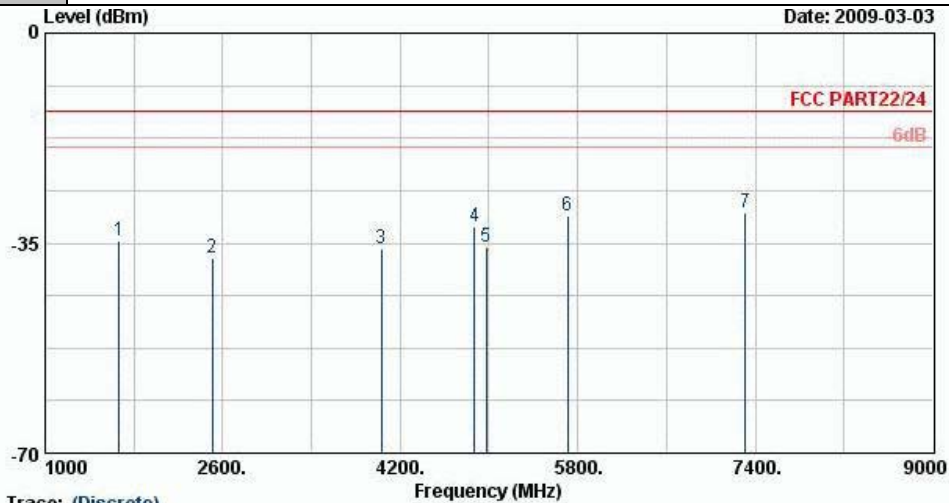

Trace: (Discrete)
 Site : 03CH07-HY
 Condition : FCC PART22/24 HF-EIRP(080306) HORIZONTAL
 Model : FG921118

Frequency (MHz)	ERP (dBm)	Limit (dBm)	Over Limit (dB)	SPA Reading (dBm)	S.G. Power (dBm)	TX Cable loss (dB)	TX Antenna Gain (dBi)	Polarization (H/V)	Result
1669	-34.66	-13	-21.66	-43.08	-33.67	3.39	4.55	H	Pass
2509	-37.35	-13	-24.35	-45.51	-37.41	3.71	5.92	H	Pass
4030	-35.83	-13	-22.83	-48.95	-35.32	5.87	7.51	H	Pass
4870	-32.21	-13	-19.21	-46.49	-31.83	5.88	7.65	H	Pass
4975	-35.76	-13	-22.76	-50.38	-35.43	5.88	7.70	H	Pass
5710	-30.46	-13	-17.46	-48.34	-30.58	6.31	8.58	H	Pass
7310	-29.89	-13	-16.89	-53.89	-30.00	6.30	8.56	H	Pass



Band :	GSM850	Temperature :	24~26°C
Test Mode :	GPRS Link + WLAN Link	Relative Humidity :	41~43%
Test Engineer :	Elvis Chen	Polarization :	Vertical
Remark :	Spurious emissions within 30-1000MHz were found more than 20dB below limit line.		

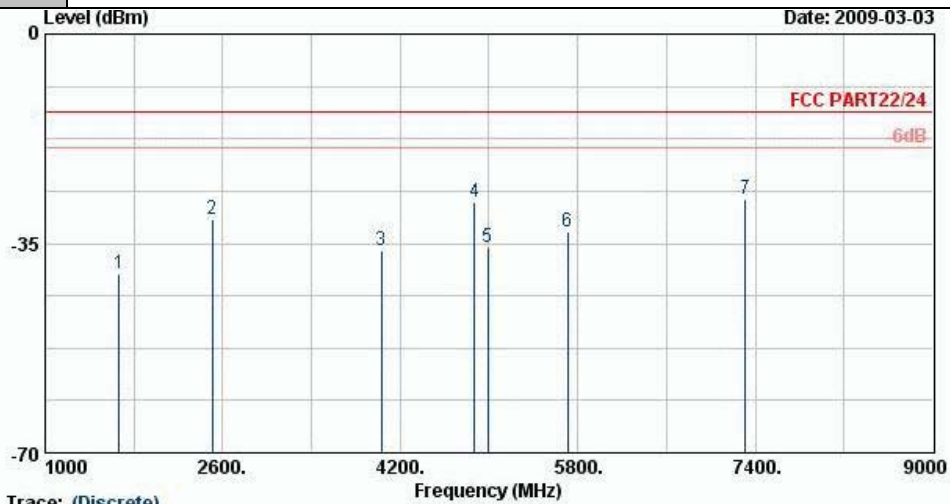

Site : 03CH07-HY
 Condition : FCC PART22/24 HF-EIRP(080306) VERTICAL
 Model : FG921118

Frequency (MHz)	ERP (dBm)	Limit (dBm)	Over Limit (dB)	SPA Reading (dBm)	S.G. Power (dBm)	TX Cable loss (dB)	TX Antenna Gain (dBi)	Polarization (H/V)	Result
1669	-39.95	-13	-26.95	-45.81	-38.57	3.39	4.16	V	Pass
2509	-30.86	-13	-17.86	-42.55	-30.72	3.71	5.72	V	Pass
4030	-36.24	-13	-23.24	-50.11	-35.73	5.87	7.51	V	Pass
4870	-28.03	-13	-15.03	-42.68	-27.65	5.88	7.65	V	Pass
4990	-35.55	-13	-22.55	-50.39	-35.22	5.88	7.70	V	Pass
5710	-33.05	-13	-20.05	-50.70	-33.17	6.31	8.58	V	Pass
7310	-27.57	-13	-14.57	-51.08	-27.68	6.30	8.56	V	Pass



4 List of Measuring Equipments

Instrument	Manufacturer	Model No.	Serial No.	Characteristics	Calibration Date	Due Date	Remark
System Simulator	R&S	CMU200	105934	N/A	Nov. 08, 2008	Nov. 07, 2009	Conducted (TH02-HY)
Spectrum Analyzer	R&S	FSP40	100055	9kHz~40GHz	Jun. 26, 2008	Jun. 25, 2009	Conducted (TH02-HY)
Thermal Chamber	TEN BILLION	TTH-D35P	TBN-930701	N/A	Aug. 01, 2008	Jul. 31, 2009	Conducted (TH02-HY)
Bilog Antenna	SCHAFFNER	CBL6111C	2726	30MHz~1GHz	Nov. 20, 2008	Nov. 19, 2009	Radiation (03CH07-HY)
Spectrum Analyzer	R&S	FSP	101067	9kHz~30GHz	Dec. 02, 2008	Dec. 01, 2009	Radiation (03CH07-HY)
Double Ridge Horn Antenna	ESCO	3117	75962	1G~18GHz	Aug. 13, 2008	Aug. 12, 2009	Radiation (03CH07-HY)
Pre Amplifier	Agilent	8449B	3008A02362	1G~26.5GHz	Dec. 17, 2008	Dec. 16, 2009	Radiation (03CH07-HY)
Pre Amplifier	COM-POWER	PA-103A	161241	10~1000MHz. 32dB.GAIN	Mar. 31, 2008	Mar. 30, 2009	Radiation (03CH07-HY)
Double Ridge Horn Antenna	ESCO	3117	66584	1G~18GHz	Aug. 06, 2008	Aug. 05, 2009	Radiation (03CH07-HY)
System Simulator	Agilent	8960	GB43460754	N/A	May 20, 2008	May 19, 2009	Radiation (03CH07-HY)

5 Uncertainty of Evaluation

Uncertainty of Radiated Emission Measurement (30 MHz ~ 1000 MHz)

Contribution	Uncertainty of x_i		$u(x_i)$
	dB	Probability Distribution	
Receiver reading	0.41	Normal(k=2)	0.21
Antenna factor calibration	0.83	Normal(k=2)	0.42
Cable loss calibration	0.25	Normal(k=2)	0.13
Pre Amplifier Gain calibration	0.27	Normal(k=2)	0.14
RCV/SPA specification	2.50	Rectangular	0.72
Antenna Factor Interpolation for Frequency	1.00	Rectangular	0.29
Site imperfection	1.43	Rectangular	0.83
Mismatch	+0.39/-0.41	U-shaped	0.28
Combined standard uncertainty Uc(y)	1.27		
Measuring uncertainty for a level of confidence of 95% U=2Uc(y)	2.54		

Uncertainty of Radiated Emission Measurement (1 GHz ~ 40 GHz)

Contribution	Uncertainty of x_i		$u(x_i)$	C_i	$C_i * u(x_i)$
	dB	Probability Distribution			
Receiver reading	±0.10	Normal(k=1)	0.10	1	0.10
Antenna factor calibration	±1.70	Normal(k=2)	0.85	1	0.85
Cable loss calibration	±0.50	Normal(k=2)	0.25	1	0.25
Receiver Correction	±2.00	Rectangular	1.15	1	1.15
Antenna Factor Directional	±1.50	Rectangular	0.87	1	0.87
Site imperfection	±2.80	Triangular	1.14	1	1.14
Mismatch Receiver VSWR $\Gamma_1 = 0.197$ Antenna VSWR $\Gamma_2 = 0.194$ Uncertainty = $20 \log(1 - \Gamma_1 * \Gamma_2)$	+0.34/-0.35	U-shaped	0.244	1	0.244
Combined standard uncertainty Uc(y)	2.36				
Measuring uncertainty for a level of confidence of 95% U=2Uc(y)	4.72				

6 Certification of TAF Accreditation



Certificate No. : L1190-081212

財團法人全國認證基金會
Taiwan Accreditation Foundation

Certificate of Accreditation

This is to certify that

Sporton International Inc.
EMC & Wireless Communications Laboratory
No.52, Hwa Ya 1st Rd., Hwa Ya Technology Park, Kwei-Shan Hsiang, Tao Yuan Hsien,
Taiwan, R.O.C.

is accredited in respect of laboratory

Accreditation Criteria	: ISO/IEC 17025:2005
Accreditation Number	: 1190
Originally Accredited	: December 15, 2003
Effective Period	: January 10, 2007 to January 09, 2010
Accredited Scope	: Testing Field, see described in the Appendix
Specific Accreditation Program	: Accreditation Program for Designated Testing Laboratory for Commodities Inspection Accreditation Program for Telecommunication Equipment Testing Laboratory Accreditation Program for BSMI Mutual Recognition Arrangement with Foreign Authorities

Jay-San Chen
President, Taiwan Accreditation Foundation
Date : December 12, 2008

PI, total 18 pages

The Appendix forms an integral part of this Certificate, which shall be invalid when use without the Appendix



Appendix A. Photographs of EUT

Please refer to Sporton report number EP921118 as below.