

Specific Absorption Rate (SAR) Test Report

for

Acer Inc.

on the

Notebook Personal Computer

Model Number: MS2154

Test Report: EME-040193



Date of Report: Mar. 11, 2004

Date of test: Mar. 5, 2004

Total No of Pages Contained in this Report: 76

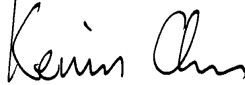

Accredited for testing to FCC Part 15

Tested by: Kevin Chen	
Reviewed by: Elton Chen	

Review Date: Mar. 12, 2004

All services undertaken are subject to the following general policy: Reports are submitted for exclusive use of the client to whom they are addressed. Their significance is subject to the adequacy and representative character of the samples and to the comprehensiveness of the tests, examinations or surveys made. This report shall not be reproduced except in full, without written consent of Intertek Testing Services, Taiwan Ltd.

Table of Contents

- 1.0 Job Description 4
 - 1.1 Client Information 4
 - 1.2 Equipment under test (EUT) 4
 - 1.3 Test plan reference 5
 - 1.4 System test configuration 5
 - 1.4.1 System block diagram & Support equipment 5
 - 1.4.2 Test Position 6
 - 1.4.3 Test Condition 6
 - 1.5 Modifications required for compliance 7
 - 1.6 Additions, deviations and exclusions from standards 7
- 2.0 SAR Evaluation 8
 - 2.1 SAR Limits 8
 - 2.2 Configuration Photographs 9
 - 2.3 SAR measurement system 13
 - 2.4 SAR measurement system validation 14
 - 2.4.1 System Validation result 15
 - 2.4.2 System Performance Check result 17
 - 2.5 Test Result 19
- 3.0 Test Equipment 21
 - 3.1 Equipment List 21
 - 3.2 Tissue Simulating Liquid 22
 - 3.2.1 Body Tissue Simulating Liquid for evaluation test 22
 - 3.2.2 Head Tissue Simulating Liquid for System performance Check test 22
 - 3.2.3 Body Liquid results 23
 - 3.2.4 Head Liquid results 24
 - 3.3 E-Field Probe and 2450 Balanced Dipole Antenna Calibration 25
- 4.0 Measurement Uncertainty 26
- 5.0 Measurement Traceability 29
- 6.0 WARNING LABEL INFORMATION - USA 29
- 7.0 REFERENCES 30
- 8.0 DOCUMENT HISTORY 31
- APPENDIX A - SAR Evaluation Data 32
- APPENDIX B - Photographs 48
- APPENDIX C - E-Field Probe and 2450MHz Balanced Dipole Antenna Calibration Data 51

STATEMENT OF COMPLIANCE

The Acer sample device, model # MS2154 was evaluated in accordance with the requirements for compliance testing defined in FCC OET Bulletin 65, Supplement C (Edition 01-01). Testing was performed at the Intertek Testing Services facility in Hsinchu, Taiwan.

For the evaluation, the dosimetric assessment system INDEXSAR SARA2 was used. The phantom employed was the box phantom of 2mm thick in one wall. The total uncertainty for the evaluation of the spatial peak SAR values averaged over a cube of 1g tissue mass had been assessed for this system to be $\pm 29.7\%$.

The device was tested at their maximum output power declared by the Acer.

In summary, the maximum spatial peak SAR value for the sample device averaged over 1g was found to be:

Phantom	Position	SAR_{1g}, W/kg
2mm thick box phantom wall	EUT rear to the phantom, 0 mm separation with WNC antenna	0.444 W/kg
2mm thick box phantom wall	EUT rear to the phantom, 0 mm separation with Hannstar antenna	0.327 W/kg

In conclusion, the tested Sample device was found to be in compliance with the requirements defined in OET Bulletin 65, Supplement C (Edition 01-01) for body configurations.

1.0 Job Description

1.1 Client Information

The MS2154 has been tested at the request of:

Company: Acer Inc.
8F, 88, Sec. 1, Hsin Tai Wu Rd., Hsichih, Taipei Hsien 221,
Taiwan

1.2 Equipment under test (EUT)

Product Descriptions:

Equipment	Notebook Personal Computer		
Trade Name	Acer	Model No:	MS2154
FCC ID	HLZMS2154RM8	S/N No.	Not Labeled
Category	Portable	RF Exposure	Uncontrolled Environment
Frequency Band	2412 – 2462 MHz	System	DSSS, OFDM

EUT Antenna Description (with Hannstar antenna)			
Type	PIFA	Configuration	Fixed
Dimensions	42 x 5 mm	Gain	0.99 dBi
Location	Embedded		

EUT Antenna Description (with WNC antenna)			
Type	PIFA	Configuration	Fixed
Dimensions	41 x 5 mm	Gain	2.76 dBi
Location	Embedded		

Use of Product : Wireless Data Communication

Manufacturer: Acer

Production is planned: [X] Yes, [] No

EUT receive date: Mar. 4, 2004

EUT received condition: Good operating condition prototype

Test start date: Mar. 4, 2004

Test end date: Mar. 5, 2004

1.3 Test plan reference

FCC Rule: Part 2.1093, FCC's OET Bulletin 65, Supplement C (Edition 01-01) and IEEE 1528/D1.2

1.4 System test configuration

1.4.1 System block diagram & Support equipment

Support Equipment				
Item #	Equipment	Brand	Model No.	S/N
1	N/A	N/A	N/A	N/A



1.4.2 Test Position

See the photographs as section 2.2

1.4.3 Test Condition

During tests the worst-case data (max RF coupling) was determined with following conditions:

Usage	Operates with a portable computer	Distance between antenna axis at the joint and the liquid surface:	Laptop is touching the Phantom in bottom position, separating 0mm and 15mm in rear and right position.	
Simulating human Head/ Body/Hand	Body	EUT Battery	Device is powered from host computer through battery.	
802.11b Conducted output Power	Channel	Frequency MHz	Before SAR Test (dBm)	After SAR Test (dBm)
	Low Channel - 1	2412	17.006	-
	Mid Channel - 6	2437	16.662	-
	High Channel- 11	2462	16.443	-
802.11g Conducted output Power	Channel	Frequency MHz	Before SAR Test (dBm)	After SAR Test (dBm)
	Low Channel - 1	2412	19.224	-
	Mid Channel - 6	2437	19.193	19.192
	High Channel- 11	2462	18.943	-

The spatial peak SAR values were assessed for lowest, middle and highest operating channels, defined by the manufacturer.

The conducted output power was measured before and after the test using a diode detector, oscilloscope and signal generator.

Run the test file “MFG TEST” under Windows OS. The EUT was transmitted continuously during the test.

The EUT has two kinds of antennas, which are Hannstar and WNC antennas. We all tested Hannstar and WNC antennas recorded in this report.

The EUT has two modules, which are WLAN and Bluetooth. The two modules transmitted at the same time during the test. For the WLAN module, it contains 802.11b and 802.11g functions, due to the worst case output power was found in 802.11g function, we only performed the 802.11g for SAR testing.

After verifying the maximum output power, we found the maximum output power was occurred at 6Mbps data rate.

All the test data were performed under the above transmission rate.

1.5 Modifications required for compliance

Intertek Testing Services implemented no modifications.

1.6 Additions, deviations and exclusions from standards

The phantom employed was the box phantom of 2mm thick in vertical wall.

2.0 SAR Evaluation

2.1 SAR Limits

The following FCC limits for SAR apply to devices operate in General Population/Uncontrolled Exposure environment:

EXPOSURE (General Population/Uncontrolled Exposure environment)	SAR (W/kg)
Average over the whole body	0.08
Spatial Peak (1g)	1.60
Spatial Peak for hands, wrists, feet and ankles (10g)	4.00

2.2 Configuration Photographs

SAR Measurement Test Setup

Test System



SAR Measurement Test Setup

EUT Bottom to the phantom, 0 mm separation

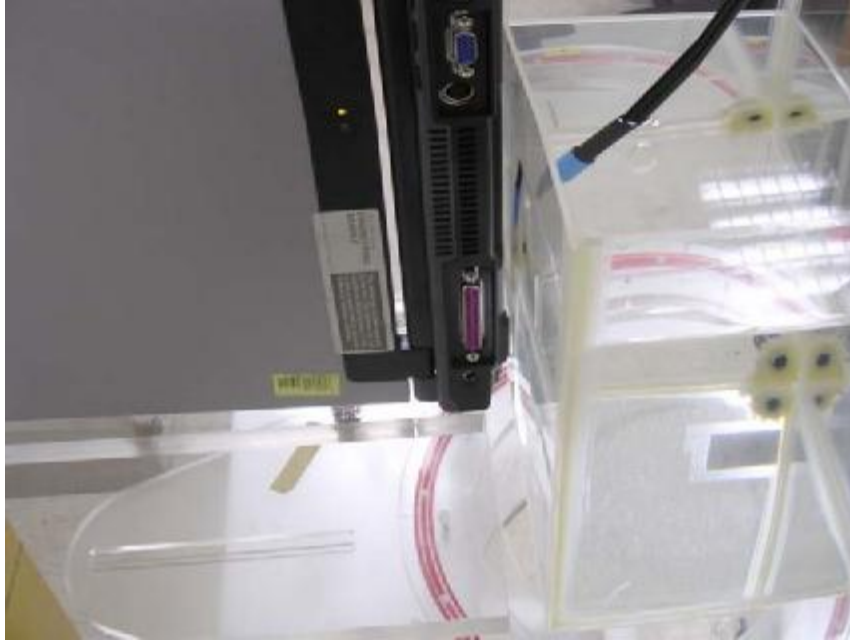

EUT rear to the phantom, 0 mm separation

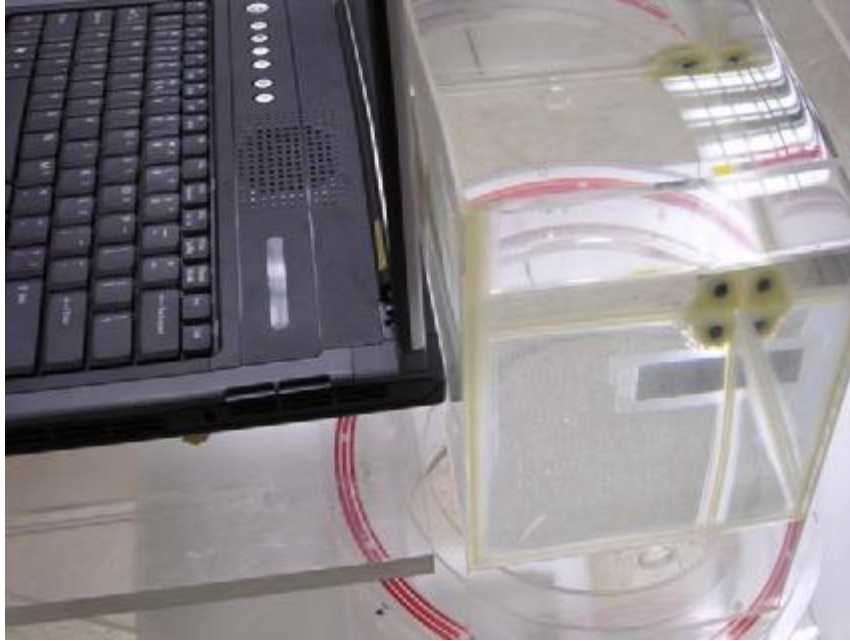

EUT rear to the phantom, 15 mm separation

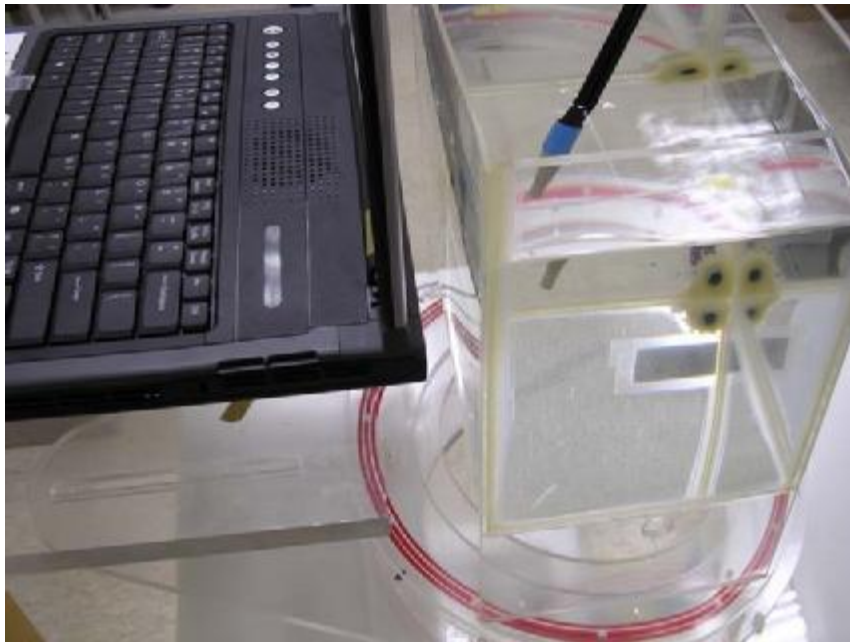

EUT right to the phantom, 0 mm separation



EUT right to the phantom, 15 mm separation



2.3 SAR measurement system

Robot system specification

The SAR measurement system being used is the IndexSAR SARA2 system, which consists of a Mitsubishi RV-E2 6-axis robot arm and controller, IndexSAR probe and amplifier and SAM phantom Head Shape. The robot is used to articulate the probe to programmed positions inside the phantom head to obtain the SAR readings from the DUT.

The system is controlled remotely from a PC, which contains the software to control the robot and data acquisition equipment. The software also displays the data obtained from test scans.

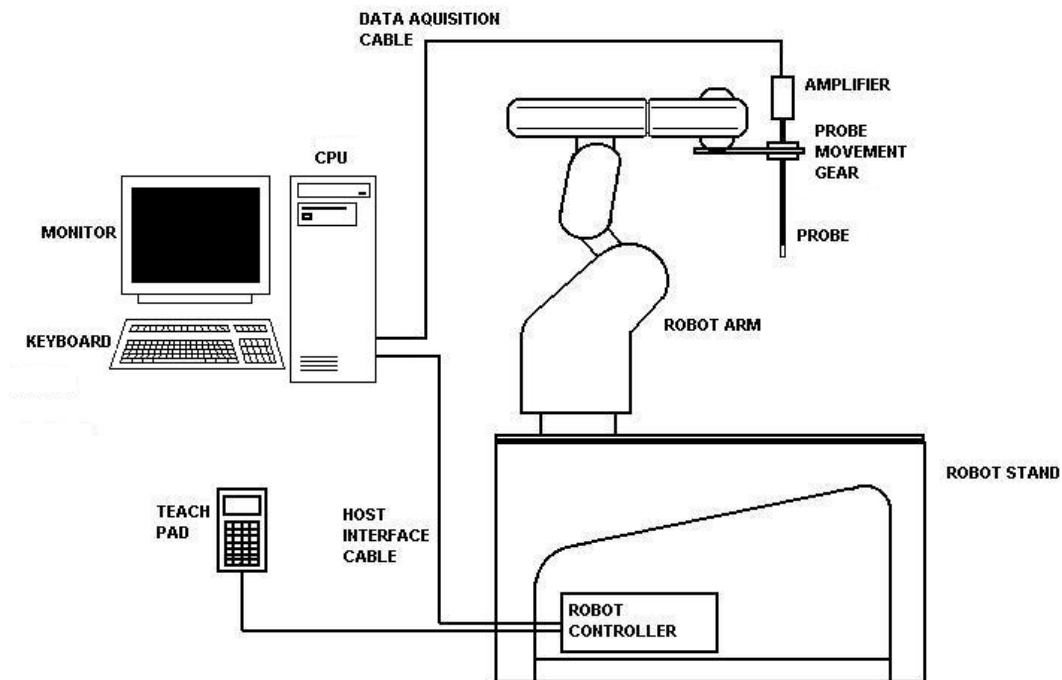

Figure 1: Schematic diagram of the SAR measurement system

The position and digitised shape of the phantom heads are made available to the software for accurate positioning of the probe and reduction of set-up time.

The SAM phantom heads are individually digitised using a Mitutoyo CMM machine to a precision of 0.02mm. The data is then converted into a shape format for the software, providing an accurate description of the phantom shell. In operation, the system first does an area (2D) scan at a fixed depth within the liquid from the inside wall of the phantom. When the maximum SAR point has been found, the system will then carry out a 3D scan centred at that point to determine volume averaged SAR level.

The first 2 measurements points in a direction perpendicular to the surface of the phantom during the zoom scan and closest to the phantom surface, were only 3.5mm and the probe is kept at greater than half a diameter from the surface.

2.4 SAR measurement system validation

Prior to the assessment, the system was verified to the $\pm 10\%$ of the specifications by using the system validation equipments. The validation was performed at 2450 MHz on the bottom side of box phantom.

Procedures

The SAR evaluation was performed with the following procedures:

- a. The SAR distribution was measured at the exposed side of the bottom of the box phantom and was measured at a distance of 8 mm from the inner surface of the shell. The feed power was $1/5W$.
- b. The dimension for this cube is 32 mm x 32 mm x 34 mm was assessed by measuring 5 x 5 x 7 points. On the basis of this data set, the spatial peak SAR value was evaluated with the following procedure:
 - i) The data at the surface were extrapolated, since the center of the dipoles is 2.7 mm away from the tip of the probe and the distance between the surface and the lowest measurement point is 5 mm. The extrapolation was based on a least square algorithm. A polynomial of the fourth order was calculated through the points in Z-axes. This polynomial was then used to evaluate the points between the surface and the probe tip.
 - ii) The maximum interpolated value was searched with a straightforward algorithm. Around this maximum, the SAR values averaged over the spatial volumes (1g or 10g) were computed using the 3-D spline interpolation algorithm. The 3-D spline is composed of three one-dimensional splines with the "Not a knot" condition (in x, y and z directions). The volume was integrated with the trapezoidal algorithm. 1000 points (10 x 10 x 10) were interpolated to calculate the average.
 - iii) All neighboring volumes were evaluated until no neighboring volume with a higher average value was found.

The test scan procedure for system validation also apply to the general scan procedure except for the set-up position. For general scan, the EUT was placed at the side of phantom. For validation scan, the dipole antenna was placed at the bottom of phantom

2.4.1 System Validation result

System Validation (2450 MHz Head)				
Frequency MHz	Operating Mode	Target SAR_{1g} (mW/g)	Measured SAR_{1g} (mW/g)	Deviation (±10%)
2450	CW	52.4	54.688	4.37%

Please see the plot below:

Date: 2003/10/15	Position: Bottom
Filename: 2450val10-15.txt	Phantom: Box1.csv
Device Tested: SARA2 system	Head Rotation: 0
Antenna: 2450dipole	Test Frequency: 2450MHz
Shape File: none.csv	Power Level: 24dBm /CW

Probe:	0136			
Cal File:	SN0136_2450_CW_HEAD			
Cal Factors:	X	Y	Z	
	Air	490	405	405
	DCP	20	20	20
	Lin	.453	.453	.453
Amp Gain:	2			
Averaging:	1			
Batteries Replaced:	-			

Liquid:	15.5cm
Type:	2450MHz Head
Conductivity:	1.80379
Relative Permittivity:	38.1223
Liquid Temp (deg C):	23.3
Ambient Temp (deg C):	24
Ambient RH (%):	50
Density (kg/m3):	1000
Software Version:	0.421N

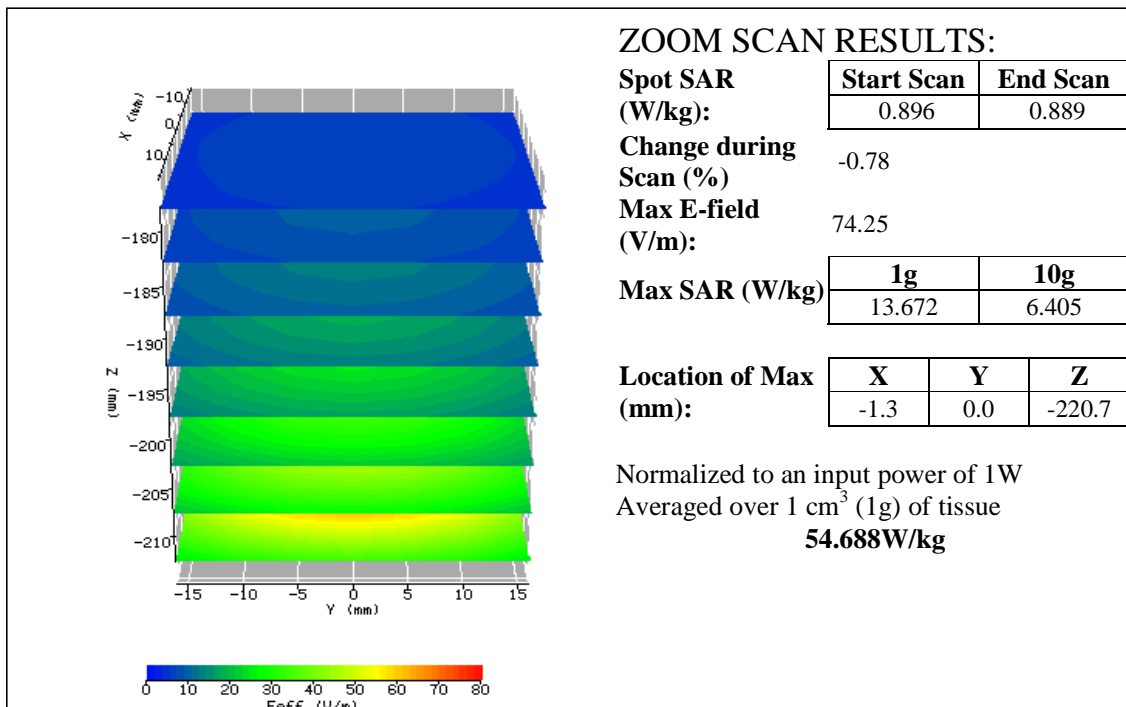

2.4.2 System Performance Check result

System performance check (2450 MHz Head)				
Frequency MHz	Operating Mode	Target SAR_{1g} (mW/g)	Measured SAR_{1g} (mW/g)	Deviation (±10%)
2450	CW	52.4	49.985	-4.608%

Please see the plot below:

Date / Time: 2004/3/4	Position: Bottom of box phantom
Filename: 2450performance check	Phantom: HeadBox1-val..csv
Device Tested: 2450 performance check	Head Rotation: 0
Antenna: 2450 dipole	Test Frequency: 2450Mhz
Shape File: none.csv	Power Level: 23 dBm

Probe:	0136			
Cal File:	SN0136_2450_CW_HEAD			
Cal Factors:		X	Y	Z
	Air	490	405	405
	DCP	20	20	20
	Lin	.378	.378	.378
Amp Gain:	2			
Averaging:	1			
Batteries Replaced:	-			

Liquid:	15.5cm
Type:	2450MHz Head
Conductivity:	1.84539
Relative Permittivity:	38.30642
Liquid Temp (deg C):	22.5
Ambient Temp (deg C):	23
Ambient RH (%):	50
Density (kg/m3):	1000
Software Version:	2.2 VPM

ZOOM SCAN RESULTS:

Spot SAR (W/kg):	Start Scan	End Scan	
	0.589	0.589	
Change during Scan (%)	0.00		
Max E-field (V/m):	60.58		
Max SAR (W/kg)	1g	10g	
	9.997	4.872	
Location of Max (mm):	X	Y	Z
	0.0	0.0	-221.9

Normalized to an input power of 1W
Averaged over 1 cm³ (1g) of tissue
49.985W/kg

2.5 Test Result

The results on the following page(s) were obtained when the device was tested in the condition described in this report. Detailed measurement data and plots, which reveal information about the location of the maximum SAR with respect to the device, are reported in Appendix A.

Measurement Results

Trade Name:	Acer	Model No.:	MS2154
Serial No.:	Not Labeled	Test Engineer:	Kevin Chen
TEST CONDITIONS			
Ambient Temperature	23 °C	Relative Humidity	50 %
Test Signal Source	Test Mode	Signal Modulation	OFDM
Output Power Before SAR Test	See page 6	Output Power After SAR Test	See page 6
Test Duration	23 min. each scan	Number of Battery Change	1

EUT Position (with WNC antenna)						
Channel (MHz)	Operating Mode	Crest Factor	Description	Distance (mm)	Measured SAR_{1g} (W/kg)	Plot Number
2437	OFDM	1	Rear to the phantom	0	0.444	1
2437	OFDM	1	Rear to the phantom	15	Note 1	2
2437	OFDM	1	Bottom to phantom-1	0	0.033	3
2437	OFDM	1	Bottom to phantom-2	0	0.039	4
2437	OFDM	1	Right to phantom	0	Note 1	5
2437	OFDM	1	Right to phantom	15	Note 1	6

EUT Position (with Hannstar antenna)						
Channel (MHz)	Operating Mode	Crest Factor	Description	Distance (mm)	Measured SAR_{1g} (W/kg)	Plot Number
2437	OFDM	1	Rear to the phantom	0	0.327	7
2437	OFDM	1	Rear to the phantom	15	Note 1	8
2437	OFDM	1	Bottom to phantom	0	Note 1	9
2437	OFDM	1	Right to phantom	0	Note 1	10
2437	OFDM	1	Right to phantom	15	Note 1	11

Note: 1. The measurement was only performed in Area Scan due to scanning system couldn't continue performing Zoom Scan with such a low SAR distribution.
2. Configuration at middle channel with more than -3dB of applicable limit.

3.0 Test Equipment

3.1 Equipment List

The Specific Absorption Rate (SAR) tests were performed with the INDEXSAR SARA2 SYSTEM.

The following major equipment/components were used for the SAR evaluations:

SAR Measurement System			
EQUIPMENT	SPECIFICATIONS	S/N #	LAST CAL. DATE
Balanced Validation dipole	2450MHz	0048	03/26/2003
Controller	Mitsubishi CR-E116	F1008007	N/A
Robot	Mitsubishi RV-E2	EA009002	N/A
	Repeatability: ± 0.04mm; Number of Axes: 6		
E-Field Probe	IXP-050	0136	09/10/2003
	Frequency Range: Probe outer diameter: 5.2 mm; Length: 350 mm; Distance between the probe tip and the dipole center: 2.7 mm		
Data Acquisition	SARA2	N/A	N/A
	Processor: Pentium 4; Clock speed: 1.5GHz; OS: Windows XP; I/O: two RS232; Software: SARA2 ver. 2.2VPM		
Phantom	2mm wall thickness box phantom	N/A	N/A
	Shell Material: clear Perspex; Thickness: 2 ± 0.1 mm; Capacity: 152.5 x 215.5 x 200 (W x L x D) mm ³ ; Dielectric constant: less than 2.85 above 500MHz;		
Device holder	Material: clear Perspex; Dielectric constant: less than 2.85 above 500MHz	N/A	N/A
Simulated Tissue	Mixture	N/A	03/04/2004
	Please see section 3.2 for details		
RF Power Meter	Boonton 4231A with 51011-EMC power sensor	79401-32482	03/21/2003
	Frequency Range: 0.03 to 8 GHz, <24dBm		
RF Power Amplifier	INDEXSAR VTL5400	0302	01/23/2004
	10MHz to 2.5GHz, Gain >30dB		
Directional Coupler	INDEXSAR VDC0830-20	0302	N/A
	0.8 to 3 GHz, Max. Power<500W		
Vector Network Analyzer	HP 8753B HP 85046A	2807J04037 2729A01958	07/04/2003
	300k to 3GHz		
Signal Generator	R&S SMR27	100036	09/19/2003
	10M to 27GHz, <120dBuV		
Crystal Detector	Agilent 8472B	MY42240243	N/A
	10MHz to 18GHz		
Two Channel Digital Storage Oscilloscope	Tektronix TDS1012	C031679	08/16/2003

3.2 Tissue Simulating Liquid

3.2.1 Body Tissue Simulating Liquid for evaluation test

Body Ingredients Frequency (2.45 GHz)	
DGBE (Dilethylene Glycol Butyl Ether)	26.7%
Salt	0.04%
Water	73.2%

The dielectric parameters were verified prior to assessment using the HP 85046A dielectric probe kit and the HP 8753B network Analyzer. The dielectric parameters were:

Frequency (MHz)	Temp. (°C)	e _r / Relative Permittivity			s / Conductivity (mho/m)			r *(kg/m ³)
		measured	target	Δ (±5%)	measured	target	Δ (±5%)	
2450	22.7	51.14	52.7	-2.96%	1.93	1.95	-1.03%	1000

* Worst-case assumption

3.2.2 Head Tissue Simulating Liquid for System performance Check test

Head Ingredients Frequency (2.45 GHz)	
DGBE (Dilethylene Glycol Butyl Ether)	53.3%
Water	46.7%

The dielectric parameters were verified prior to assessment using the HP 85046A dielectric probe kit and the HP 8753B network Analyzer. The dielectric parameters were:

Frequency (MHz)	Temp. (°C)	e _r / Relative Permittivity			s / Conductivity (mho/m)			r *(kg/m ³)
		measured	target	Δ (±5%)	measured	target	Δ (±5%)	
2450	23.6	38.31	39.2	-2.27%	1.85	1.80	2.78	1000

* Worst-case assumption

3.2.3 Body Liquid results

Date: 4 Mar. 2004	Temperature: 22.7 °C	Type: 2450 MHz/ body (FCC)	Tested by: Kevin
2410, 50.3502305427, -1.9692170485		2450, 51.1433701903, -1.9344491973	
2411, 50.3607685768, -1.9649007539		2451, 51.1540742244, -1.9418025022	
2412, 50.3631549419, -1.9636900164		2452, 51.1500589372, -1.9414800701	
2413, 50.3594220068, -1.9657033405		2453, 51.1880161919, -1.9428372744	
2414, 50.3607069074, -1.958699449		2454, 51.235053564, -1.9439150473	
2415, 50.3668257333, -1.9511748444		2455, 51.1915213932, -1.9500808739	
2416, 50.3811022499, -1.9522199502		2456, 51.2252586791, -1.9508752042	
2417, 50.394096955, -1.9499520847		2457, 51.2894891047, -1.9573002414	
2418, 50.3885250647, -1.9452974913		2458, 51.3316920709, -1.9519881102	
2419, 50.4025872666, -1.9459797369		2459, 51.3271015737, -1.9634574442	
2420, 50.4416701841, -1.9435835173		2460, 51.3189946854, -1.9658721877	
2421, 50.4515367708, -1.936877624		2461, 51.3630940465, -1.9708713433	
2422, 50.4277519153, -1.9385606298		2462, 51.3513001661, -1.9701750293	
2423, 50.4705335137, -1.9370276245		2463, 51.3397946933, -1.9764959614	
2424, 50.5018646345, -1.9320225909		2464, 51.4166614643, -1.9808635358	
2425, 50.5037054275, -1.9305931951		2465, 51.383690754, -1.9816891272	
2426, 50.5013123295, -1.9261951276		2466, 51.4708953087, -1.9922425844	
2427, 50.5428667536, -1.9278819671		2467, 51.4309119303, -1.9921924503	
2428, 50.5547975367, -1.9309749907		2468, 51.4358483464, -2.0003914527	
2429, 50.6150508274, -1.9274471637		2469, 51.4995919912, -2.0024603449	
2430, 50.5681319458, -1.9263619639		2470, 51.4836756627, -2.0064273777	
2431, 50.6358452149, -1.9216380031		2471, 51.459010331, -2.0103701417	
2432, 50.6309847561, -1.9220734155		2472, 51.5240972696, -2.0222845553	
2433, 50.6570905197, -1.91963242		2473, 51.5007895501, -2.0205948227	
2434, 50.72962515, -1.9206694509		2474, 51.5135097539, -2.0212620572	
2435, 50.7047666201, -1.9185615057		2475, 51.5411977485, -2.0281381186	
2436, 50.7457485299, -1.919984432		2476, 51.5398826542, -2.0299519199	
2437, 50.7752631856, -1.9161183325		2477, 51.5302132225, -2.038615536	
2438, 50.8338634138, -1.9201508182		2478, 51.5396675599, -2.0400166344	
2439, 50.7908572736, -1.9191430593		2479, 51.562420507, -2.0490191126	
2440, 50.8607225888, -1.9242840218		2480, 51.5574711077, -2.0388429416	
2441, 50.887503262, -1.9220640937		2481, 51.5322069167, -2.0540643911	
2442, 50.8681916717, -1.924191626		2482, 51.5346487908, -2.0646265702	
2443, 50.9332553579, -1.9249094177		2483, 51.5395951638, -2.069237758	
2444, 50.9920379264, -1.924592361		2484, 51.5124621031, -2.0731931343	
2445, 50.9794373072, -1.9261596163		2485, 51.5635564592, -2.0742268214	
2446, 50.9976673607, -1.9311329876		2486, 51.5388528574, -2.0796924517	
2447, 51.00889867, -1.9316877656		2487, 51.5445511822, -2.0877072794	
2448, 51.0267486636, -1.9311894126		2488, 51.5179788553, -2.0934587283	
2449, 51.0736378447, -1.9312169636		2489, 51.5255529102, -2.0979232617	
		2490, 51.5482996261, -2.0995855259	

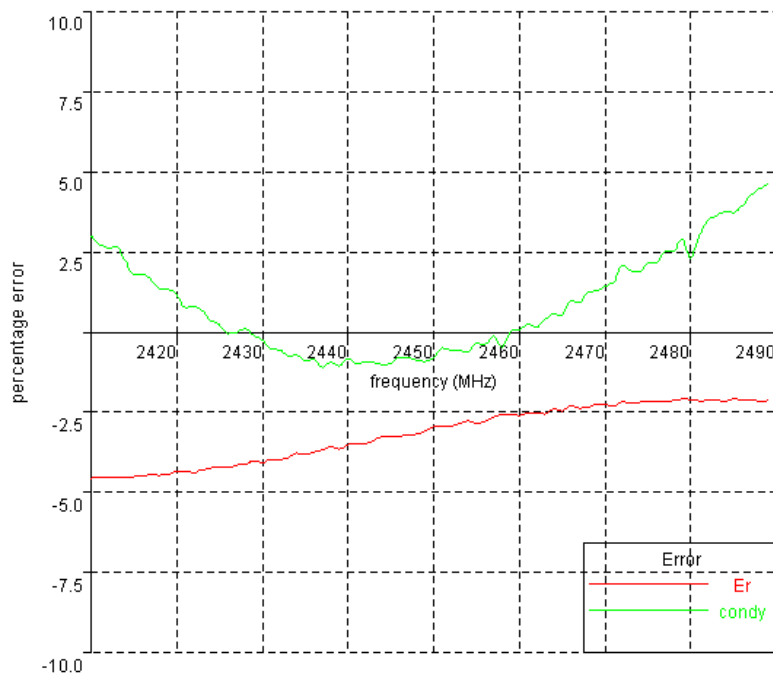

3.2.4 Head Liquid results

Date: 4 Mar. 2004	Temperature: 23.6 °C	Type:2450 MHz/ head (FCC)	Tested by: Kevin
2410, 37.649280142, -1.8688094619		2450, 38.3064241037, -1.8453943978	
2411, 37.6631552284, -1.8711914704			
2412, 37.6756160691, -1.8694608624			
2413, 37.6835013742, -1.868928721			
2414, 37.6785108098, -1.8705081998			
2415, 37.6715518385, -1.8635691928			
2416, 37.6604582782, -1.8609817721			
2417, 37.6535491557, -1.853709658			
2418, 37.6886990422, -1.8613543269			
2419, 37.6914921381, -1.8522640326			
2420, 37.7003893189, -1.8522590157			
2421, 37.7279470198, -1.8506105168			
2422, 37.703341852, -1.8504677053			
2423, 37.7249820454, -1.8490448017			
2424, 37.7033350565, -1.8434469351			
2425, 37.7606109152, -1.8441603773			
2426, 37.7540962509, -1.8467508022			
2427, 37.7697996681, -1.8389747682			
2428, 37.8397378835, -1.8340821117			
2429, 37.8648206584, -1.8359912555			
2430, 37.881950877, -1.8378504214			
2431, 37.8759675906, -1.8374076479			
2432, 37.8592478039, -1.8307885294			
2433, 37.9182922237, -1.8313187885			
2434, 37.9750641041, -1.8333483433			
2435, 37.9433515982, -1.8348644429			
2436, 37.9954060642, -1.836691635			
2437, 37.9868615681, -1.8329525027			
2438, 38.0371732728, -1.8296298634			
2439, 38.0497578572, -1.8326286488			
2440, 38.0623466052, -1.8332664273			
2441, 38.0763739212, -1.8316976065			
2442, 38.0988291359, -1.8354887401			
2443, 38.1110173751, -1.8395310278			
2444, 38.1550016733, -1.8417781246			
2445, 38.1841227687, -1.8410333038			
2446, 38.1817100557, -1.8391926047			
2447, 38.1799008306, -1.8476800064			
2448, 38.2050629316, -1.8422153068			
2449, 38.2570581029, -1.8423982629			
2450, 38.3064241037, -1.8453943978			
2451, 38.276248537, -1.8507439758			
2452, 38.3335563554, -1.8523861999			
2453, 38.3009860191, -1.8534771134			
2454, 38.381939232, -1.8591982433			
2455, 38.3908593763, -1.8653899577			
2456, 38.3843759724, -1.8608077219			
2457, 38.3894594582, -1.8667093245			
2458, 38.4031873833, -1.8719042969			
2459, 38.3908987907, -1.8708269655			
2460, 38.4820309691, -1.8729353602			
2461, 38.4589207052, -1.8815466656			
2462, 38.4919691669, -1.8788489662			
2463, 38.4777823835, -1.8824468757			
2464, 38.4432214024, -1.8902367951			
2465, 38.4730308494, -1.894643617			
2466, 38.5383243982, -1.8936683492			
2467, 38.5251034063, -1.9014621814			
2468, 38.5265076463, -1.9103208134			
2469, 38.5160046535, -1.9039909656			
2470, 38.5306204861, -1.9043422992			
2471, 38.5255177346, -1.906046946			
2472, 38.6029513364, -1.9201083771			
2473, 38.5522425301, -1.9201771494			
2474, 38.5508373009, -1.9189740234			
2475, 38.5707144384, -1.9287142412			
2476, 38.5426243905, -1.9308171589			
2477, 38.5917962836, -1.933421275			
2478, 38.5871073803, -1.9418121068			
2479, 38.5747599353, -1.9465573231			
2480, 38.5946494075, -1.9511427692			
2481, 38.5739094134, -1.9563253101			
2482, 38.5946425027, -1.9614149778			
2483, 38.5747461328, -1.961895312			
2484, 38.5458101426, -1.9716109487			
2485, 38.5434216208, -1.968582962			
2486, 38.5415952561, -1.9764820839			
2487, 38.5600620628, -1.9772266779			
2488, 38.5582349096, -1.9892159275			
2489, 38.5274396789, -1.9827844253			
2490, 38.4446282851, -1.9991354331			

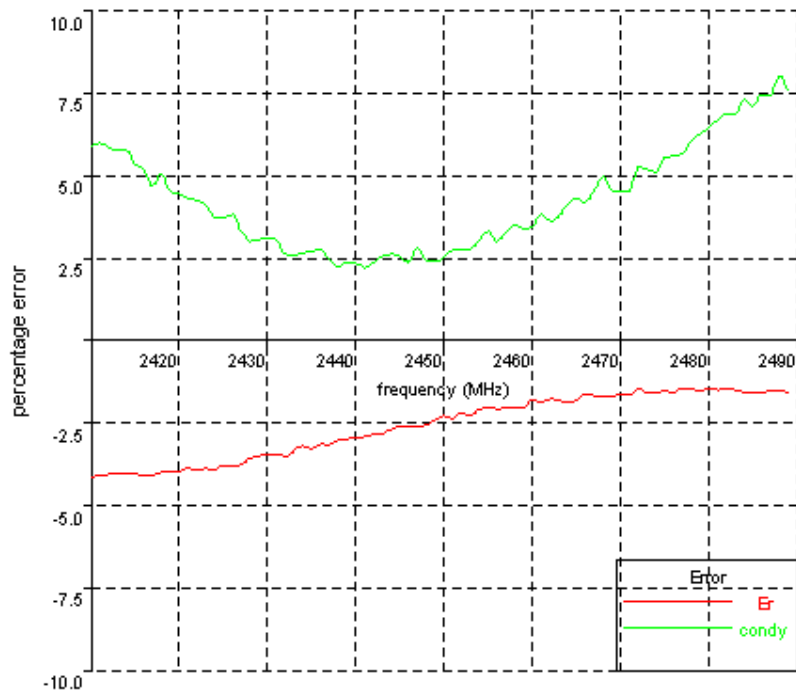

3.3 E-Field Probe and 2450 Balanced Dipole Antenna Calibration

Probe calibration factors and dipole antenna calibration are included in Appendix C.

4.0 Measurement Uncertainty

The uncertainty budget has been determined for the INDEXSAR SARA2 measurement system according to IEEE P1528 documents [3] and is given in the following table. The extended uncertainty (95% confidence level) was assessed to be 29.7 %

Table 1 Exposure Assessment Uncertainty
Example of measurement uncertainty assessment SAR measurement

(blue entries are site-specific)

a Uncertainty Component	b Sec.	Tol. (+/-)		c Prob. Dist.	d Divisor (descrip)	e Divisor (value)	f		g		h Standard Uncertainty (% 1g)	i Standard Uncertainty (% 10g)
		(dB)	(%)				c1 (1g)	c1 (10g)				
Measurement System												
Probe Calibration	E2.1			2.5	N	1 or k	1	1	1		2.50	2.50
Axial Isotropy	E2.2	0.25	5.93	5.93	R	$\sqrt{3}$	1.73	0	0		0.00	0.00
Hemispherical Isotropy	E2.2	0.45	10.92	10.92	R	$\sqrt{3}$	1.73	1	1		6.30	6.30
Boundary effect	E2.3		4	4.00	R	$\sqrt{3}$	1.73	1	1		2.31	2.31
Linearity	E2.4	0.04	0.93	0.93	R	$\sqrt{3}$	1.73	1	1		0.53	0.53
System Detection Limits	E2.5		1	1.00	R	$\sqrt{3}$	1.73	1	1		0.58	0.58
Readout Electronics	E2.6		1	1.00	N	1 or k	1.00	1	1		1.00	1.00
Response time	E2.7		0	0.00	R	$\sqrt{3}$	1.73	1	1		0.00	0.00
Integration time	E2.8		1.4	1.40	R	$\sqrt{3}$	1.73	1	1		0.81	0.81
RF Ambient Conditions	E6.1		3	3.00	R	$\sqrt{3}$	1.73	1	1		1.73	1.73
Probe Positioner Mechanical Tolerance	E6.2		0.6	0.60	R	$\sqrt{3}$	1.73	1	1		0.35	0.35
Probe Position wrt. Phantom Shell	E6.3		3	3.00	R	$\sqrt{3}$	1.73	1	1		1.73	1.73
SAR Evaluation Algorithms	E5		8	8.00	R	$\sqrt{3}$	1.73	1	1		4.62	4.62
Test Sample Related												
Test Sample Positioning	E4.2		2	2.00	N	1	1.00	1	1		2.00	2.00
Device Holder Uncertainty	E4.1		2	2.00	N	1	1.00	1	1		2.00	2.00
Output Power Variation	6.6.2		5	5.00	R	$\sqrt{3}$	1.73	1	1		2.89	2.89
Phantom and Tissue Parameters												
Phantom Uncertainty (shape and thickness)	E3.1		4	4.00	R	$\sqrt{3}$	1.73	1	1		2.31	2.31
Liquid conductivity (Deviation from target)	E3.2		5	5.00	R	$\sqrt{3}$	1.73	0.64	0.43		1.85	1.24
Liquid conductivity (measurement uncert.)	E3.3		1.1	1.10	N	1	1.00	0.64	0.43		0.70	0.47
Liquid permittivity (Deviation from target)	E3.2		5	5.00	R	$\sqrt{3}$	1.73	0.6	0.49		1.73	1.41
Liquid permittivity (measurement uncert.)	E3.3		1.1	1.10	N	1	1.00	0.6	0.49		0.66	0.54
Combined standard uncertainty					RSS						10.5	10.3
Expanded uncertainty (95% Confidence Level)					k=2						20.6	20.3

Table 2 System Check (Verification)
Example of measurement uncertainty assessment for system performance check

(blue entries are site-specific)

a	b	c		d	e	f	g	h	i		
Uncertainty Component	Sec.	Tol. (+/-)		Prob. Dist.	Divisor (descrip)	Divisor (value)	c1 (1g)	c1 (10g)	Standard Uncertainty (%) 1g	Standard Uncertainty (%) 10g	
		(dB)	(%)								
Measurement System											
Probe Calibration	E2.1		2.5	N	1 or k	1	1	1	2.50	2.50	
Axial Isotropy	E2.2	0.25	5.93	5.93	R	√3	1.73	0	0	0.00	0.00
Hemispherical Isotropy	E2.2	0.45	10.92	10.92	R	√3	1.73	1	1	6.30	6.30
Boundary effect	E2.3		4	4.00	R	√3	1.73	1	1	2.31	2.31
Linearity	E2.4	0.04	0.93	0.93	R	√3	1.73	1	1	0.53	0.53
System Detection Limits	E2.5		1	1.00	R	√3	1.73	1	1	0.58	0.58
Readout Electronics	E2.6		1	1.00	N	1 or k	1.00	1	1	1.00	1.00
Response time	E2.7		0	0.00	R	√3	1.73	1	1	0.00	0.00
Integration time	E2.8		1.4	1.40	R	√3	1.73	1	1	0.81	0.81
RF Ambient Conditions	E6.1		3	3.00	R	√3	1.73	1	1	1.73	1.73
Probe Positioner Mechanical Tolerance	E6.2		0.6	0.60	R	√3	1.73	1	1	0.35	0.35
Probe Position wrt. Phantom Shell	E6.3		3	3.00	R	√3	1.73	1	1	1.73	1.73
SAR Evaluation Algorithms	E5		8	8.00	R	√3	1.73	1	1	4.62	4.62
Dipole											
Dipole axis to liquid distance	8, E4.2		2	2.00	N	1	1.00	1	1	2.00	2.00
Input power and SAR drift measurement	8, 6.6.2		5	5.00	R	√3	1.73	1	1	2.89	2.89
Phantom and Tissue Parameters											
Phantom Uncertainty (thickness)	E3.1		4	4.00	R	√3	1.73	1	1	2.31	2.31
Liquid conductivity (Deviation from target)	E3.2		5	5.00	R	√3	1.73	0.64	0.43	1.85	1.24
Liquid conductivity (measurement uncert.)	E3.3		1.1	1.10	N	1	1.00	0.64	0.43	0.70	0.47
Liquid permittivity (Deviation from target)	E3.2		5	5.00	R	√3	1.73	0.6	0.49	1.73	1.41
Liquid permittivity (measurement uncert.)	E3.3		1.1	1.10	N	1	1.00	0.6	0.49	0.66	0.54
Combined standard uncertainty					RSS					10.3	10.1
Expanded uncertainty	(95% Confidence Level)				k=2					20.2	19.9

Table 3 Uncertainty assessment for waveguide probe calibration

	a		b		c	
Uncertainty Component	Tol. (+/-%)	Prob. Dist.	Divisor (descrip)	Divisor (value)	c1	Standard Uncertainty (+/- %)
Waveguide calibrations						
Incident or forward power	1	R	$\sqrt{3}$	1.73	1	0.58
Reflected power	1.00	R	$\sqrt{3}$	1.73	1	0.58
Liquid conductivity	2.00	R	$\sqrt{3}$	1.73	1	1.15
Liquid permittivity	2.00	R	$\sqrt{3}$	1.73	1	1.15
Probe positioning	1.00	N	1	1.00	1	1.00
Field homogeneity	1.00	R	$\sqrt{3}$	1.73	1	0.58
Field probe positioning	2.00	R	$\sqrt{3}$	1.73	1	1.15
Field probe linearity	1.00	R	$\sqrt{3}$	1.73	1	0.58
Combined standard uncertainty		RSS				2.5
Expanded uncertainty		k=2				4.9

Table 4 Uncertainty assessment for DiLine dielectric property measurement

	a		b		c	
Uncertainty Component	Tol. (+/- %)	Prob. Dist.	Divisor (descrip)	Divisor (value)	c1	Standard Uncertainty (+/- %)
Permittivity measurement						
Repeatability (n repeats)	1	N	1 or k	1	1	1.00
Temperature measurement	0.30	R	$\sqrt{3}$	1.73	1	0.17
VNA drift, linearity	0.50	R	$\sqrt{3}$	1.73	1	0.29
Test port cable variations	0.50	R	$\sqrt{3}$	1.73	1	0.29
Combined standard uncertainty		RSS				1.1
Expanded uncertainty		k=2				2.1

	a		b		c	
Uncertainty Component	Tol. (+/- %)	Prob. Dist.	Divisor (descrip)	Divisor (value)	c1	Standard Uncertainty (+/- %)
Conductivity measurement						
Repeatability (n repeats)	1	N	1 or k	1	1	1.00
Temperature measurement	0.30	R	$\sqrt{3}$	1.73	1	0.17
VNA drift, linearity	0.50	R	$\sqrt{3}$	1.73	1	0.29
Test port cable variations	0.50	R	$\sqrt{3}$	1.73	1	0.29
Combined standard uncertainty		RSS				1.1
Expanded uncertainty		k=2				2.1

5.0 Measurement Traceability

All measurements described in this report are traceable to Chinese National Laboratory Accreditation (CNLA) standards or appropriate national standards.

6.0 WARNING LABEL INFORMATION - USA

See user manual.

7.0 REFERENCES

- [1] ANSI, *ANSI/IEEE C95.1-1999: IEEE Standard for Safety Levels with Respect to Human Exposure to Radio Frequency Electromagnetic Fields, 3kHz to 300 GHz*, The Institute of electrical and Electronics Engineers, Inc., New York, NY 10017, 1999
- [2] Federal Communications Commission, "Evaluating Compliance with FCC Guidelines for Human Exposure to Radiofrequency Electromagnetic Fields", Supplement C to OET Bulletin 65, Washington, D.C. 20554, 1997
- [3] IEEE Standards Coordinating Committee 34, "Recommended Practice for Determining the Peak Spatial-Average Specific Absorption Rate (SAR) in the Human Head from Wireless Communications Devices: Measurement Techniques", IEEE Std 1528/D1.2, April 21, 2003

8.0 DOCUMENT HISTORY

Revision/ Job Number	Writer Initials	Date	Change
N/A	M.W.	Mar.11, 2004	Original document

APPENDIX A - SAR Evaluation Data

Power drift is the measurement of power drift of the device over one complete SAR scan.

To assess the drift of the power of the device under test, a SAR measurement was made in the middle of the zoom scan volume at the start of the scan and a measurement at this point was then also made after the measurement scan. The difference between the two measurements should be less than 5%.

Plot #1/1

Date / Time: 2004/3/5	Position: rear 0
Filename: 11g-MS2154-rear0	Phantom: HeadBox2-test.csv
Device Tested: MS2154	Head Rotation: 0
Antenna: PIFA	Test Frequency: 2437MHz
Shape File: MS2154rear.csv	Power Level: 19.193dBm

Probe:	0136																
Cal File:	SN0136_2450_CW_BODY																
Cal Factors:	<table border="1" style="width: 100%; border-collapse: collapse;"> <thead> <tr> <th></th> <th>X</th> <th>Y</th> <th>Z</th> </tr> </thead> <tbody> <tr> <td>Air</td> <td>490</td> <td>405</td> <td>405</td> </tr> <tr> <td>DCP</td> <td>20</td> <td>20</td> <td>20</td> </tr> <tr> <td>Lin</td> <td>.405</td> <td>.405</td> <td>.405</td> </tr> </tbody> </table>		X	Y	Z	Air	490	405	405	DCP	20	20	20	Lin	.405	.405	.405
		X	Y	Z													
	Air	490	405	405													
	DCP	20	20	20													
Lin	.405	.405	.405														
Amp Gain:	2																
Averaging:	1																
Batteries Replaced:	-																

Liquid:	15.5cm
Type:	2450MHz Body
Conductivity:	1.9344
Relative Permittivity:	51.1433
Liquid Temp (deg C):	22
Ambient Temp (deg C):	20
Ambient RH (%):	40
Density (kg/m3):	1000
Software Version:	2.2VPM
Crest Factor=1	

ZOOM SCAN RESULTS:

Spot SAR (W/kg):	Start Scan	End Scan
	0.183	0.182

Change during Scan (%): 0.79

Max E-field (V/m): 18.34

Max SAR (W/kg)	1g	10g
	0.444	0.282

Location of Max (mm):	X	Y	Z
	78.0	-55.0	-159.3

Plot #1/2

AREA SCAN:

Scan Extent:

	Min	Max	Steps
Y	-70.0	20.0	9.0
Z	-185.0	-125.0	6.0

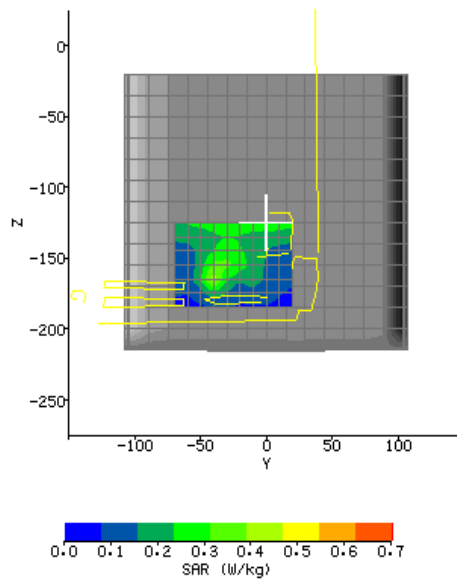

Plot #2

Date / Time: 2004/3/5	Position: rear 15
Filename: 11g-MS2154-rear15	Phantom: HeadBox2-test.csv
Device Tested: MS2154	Head Rotation: 0
Antenna: PIFA	Test Frequency: 2437MHz
Shape File: MS2154rear.csv	Power Level: 19.193dBm

Probe:	0136																
Cal File:	SN0136_2450_CW_BODY																
Cal Factors:	<table border="1" style="width: 100%; border-collapse: collapse;"> <thead> <tr> <th></th> <th>X</th> <th>Y</th> <th>Z</th> </tr> </thead> <tbody> <tr> <td>Air</td> <td>490</td> <td>405</td> <td>405</td> </tr> <tr> <td>DCP</td> <td>20</td> <td>20</td> <td>20</td> </tr> <tr> <td>Lin</td> <td>.405</td> <td>.405</td> <td>.405</td> </tr> </tbody> </table>		X	Y	Z	Air	490	405	405	DCP	20	20	20	Lin	.405	.405	.405
		X	Y	Z													
	Air	490	405	405													
	DCP	20	20	20													
Lin	.405	.405	.405														
Amp Gain:	2																
Averaging:	1																
Batteries Replaced:	1																

Liquid:	15.5cm
Type:	2450MHz Body
Conductivity:	1.9344
Relative Permittivity:	51.1433
Liquid Temp (deg C):	22
Ambient Temp (deg C):	20
Ambient RH (%):	40
Density (kg/m3):	1000
Software Version:	2.2VPM
Crest Factor=1	

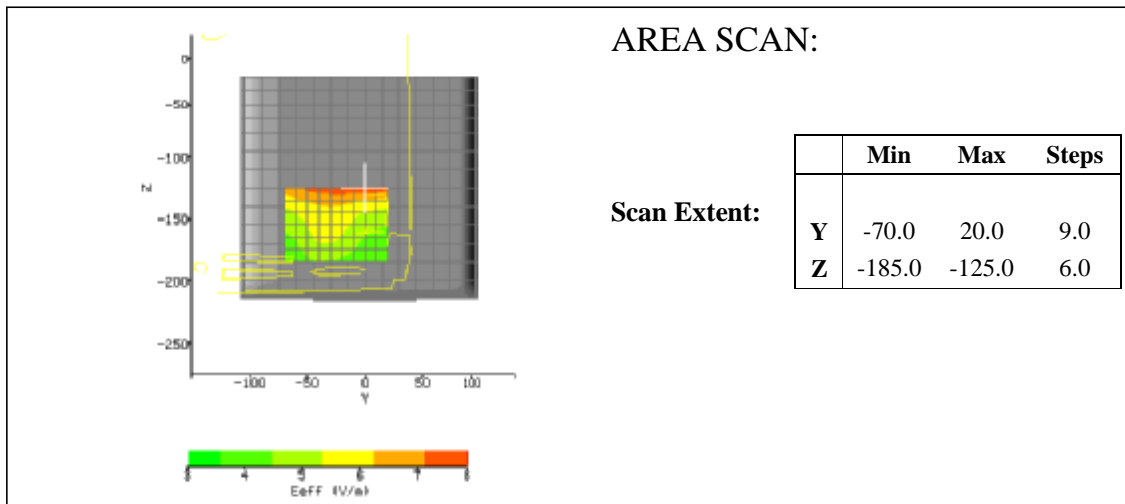

Plot #3/1

Date / Time: 2004/3/5	Position: bot-1
Filename: 11g-MS2154-bot_1	Phantom: HeadBox2-test.csv
Device Tested: MS2154	Head Rotation: 0
Antenna: PIFA	Test Frequency: 2437MHz
Shape File: MS2154bot.csv	Power Level: 19.193dBm

Probe: 0136																
Cal File: SN0136_2450_CW_BODY																
Cal Factors:																
<table border="1" style="margin-left: auto; margin-right: auto;"> <thead> <tr> <th></th> <th>X</th> <th>Y</th> <th>Z</th> </tr> </thead> <tbody> <tr> <td>Air</td> <td>490</td> <td>405</td> <td>405</td> </tr> <tr> <td>DCP</td> <td>20</td> <td>20</td> <td>20</td> </tr> <tr> <td>Lin</td> <td>.405</td> <td>.405</td> <td>.405</td> </tr> </tbody> </table>		X	Y	Z	Air	490	405	405	DCP	20	20	20	Lin	.405	.405	.405
	X	Y	Z													
Air	490	405	405													
DCP	20	20	20													
Lin	.405	.405	.405													
Amp Gain: 2																
Averaging: 1																
Batteries Replaced: -																

Liquid: 15.5cm
Type: 2450MHz Body
Conductivity: 1.9344
Relative Permittivity: 51.1433
Liquid Temp (deg C): 22
Ambient Temp (deg C): 20
Ambient RH (%): 40
Density (kg/m3): 1000
Software Version: 2.2VPM
Crest Factor=1

ZOOM SCAN RESULTS:

Spot SAR (W/kg):	Start Scan	End Scan
	0.08	0.08
Change during Scan (%)	0	
Max E-field (V/m):	5.00	
Max SAR (W/kg)	1g	10g
	0.033	0.017
Location of Max (mm):	X	Y
	78.1	-4.0
	Z	-160.0

Plot #3/2

AREA SCAN:

Scan Extent:

	Min	Max	Steps
Y	-45.0	45.0	9.0
Z	-180.0	-140.0	4.0

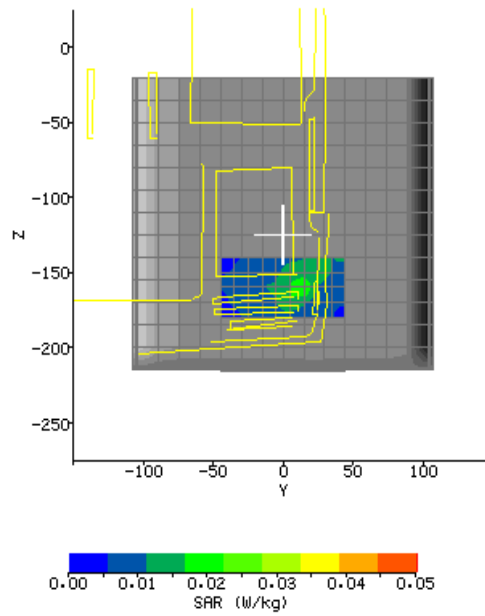

Plot #4/1

Date / Time: 2004/3/5	Position: bot-2
Filename: 11g-MS2154-bot_2.txt	Phantom: HeadBox2-test.csv
Device Tested: MS2154	Head Rotation: 0
Antenna: PIFA	Test Frequency: 2437MHz
Shape File: MS2154bot.csv	Power Level: 19.193dBm

Probe:	0136																
Cal File:	SN0136_2450_CW_BODY																
Cal Factors:	<table border="1" style="width: 100%; border-collapse: collapse;"> <thead> <tr> <th></th> <th>X</th> <th>Y</th> <th>Z</th> </tr> </thead> <tbody> <tr> <td>Air</td> <td>490</td> <td>405</td> <td>405</td> </tr> <tr> <td>DCP</td> <td>20</td> <td>20</td> <td>20</td> </tr> <tr> <td>Lin</td> <td>.405</td> <td>.405</td> <td>.405</td> </tr> </tbody> </table>		X	Y	Z	Air	490	405	405	DCP	20	20	20	Lin	.405	.405	.405
		X	Y	Z													
	Air	490	405	405													
	DCP	20	20	20													
Lin	.405	.405	.405														
Amp Gain:	2																
Averaging:	1																
Batteries Replaced:	-																

Liquid:	15.5cm
Type:	2450MHz Body
Conductivity:	1.9344
Relative Permittivity:	51.1433
Liquid Temp (deg C):	22
Ambient Temp (deg C):	20
Ambient RH (%):	40
Density (kg/m3):	1000
Software Version:	2.2VPM
Crest Factor=1	

ZOOM SCAN RESULTS:

Spot SAR (W/kg):	Start Scan	End Scan
	0.011	0.012
Change during Scan (%)	3.87	
Max E-field (V/m):	5.23	
Max SAR (W/kg)	1g	10g
	0.039	0.019
Location of Max (mm):	X	Y
	78.0	1.0
	Z	-143.9

Plot #4/2

AREA SCAN:

Scan Extent:

	Min	Max	Steps
Y	-45.0	45.0	9.0
Z	-175.0	-125.0	5.0

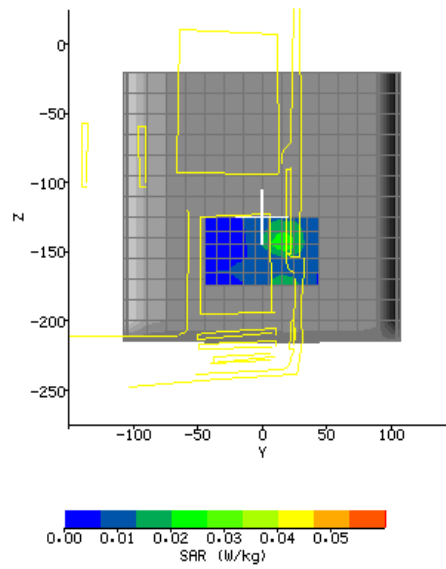

Plot #5

Date / Time: 2004/3/5	Position: right 0
Filename: 11g-MS2154-right0	Phantom: HeadBox2-test.csv
Device Tested: MS2154	Head Rotation: 0
Antenna: PIFA	Test Frequency: 2437MHz
Shape File: MS2154right.csv	Power Level: 19.193dBm

<p>Probe: 0136</p> <p>Cal File: SN0136_2450_CW_BODY</p> <table border="1" style="margin-left: 20px;"> <tr> <td></td> <td style="text-align: center;">X</td> <td style="text-align: center;">Y</td> <td style="text-align: center;">Z</td> </tr> <tr> <td style="text-align: center;">Air</td> <td style="text-align: center;">490</td> <td style="text-align: center;">405</td> <td style="text-align: center;">405</td> </tr> <tr> <td style="text-align: center;">DCP</td> <td style="text-align: center;">20</td> <td style="text-align: center;">20</td> <td style="text-align: center;">20</td> </tr> <tr> <td style="text-align: center;">Lin</td> <td style="text-align: center;">.405</td> <td style="text-align: center;">.405</td> <td style="text-align: center;">.405</td> </tr> </table> <p>Cal Factors:</p> <p>Amp Gain: 2</p> <p>Averaging: 1</p> <p>Batteries Replaced: 1</p>		X	Y	Z	Air	490	405	405	DCP	20	20	20	Lin	.405	.405	.405	<p>Liquid: 15.5cm</p> <p>Type: 2450MHz Body</p> <p>Conductivity: 1.9344</p> <p>Relative Permittivity: 51.1433</p> <p>Liquid Temp (deg C): 22</p> <p>Ambient Temp (deg C): 20</p> <p>Ambient RH (%): 40</p> <p>Density (kg/m3): 1000</p> <p>Software Version: 2.2VPM</p> <p>Crest Factor=1</p>
	X	Y	Z														
Air	490	405	405														
DCP	20	20	20														
Lin	.405	.405	.405														

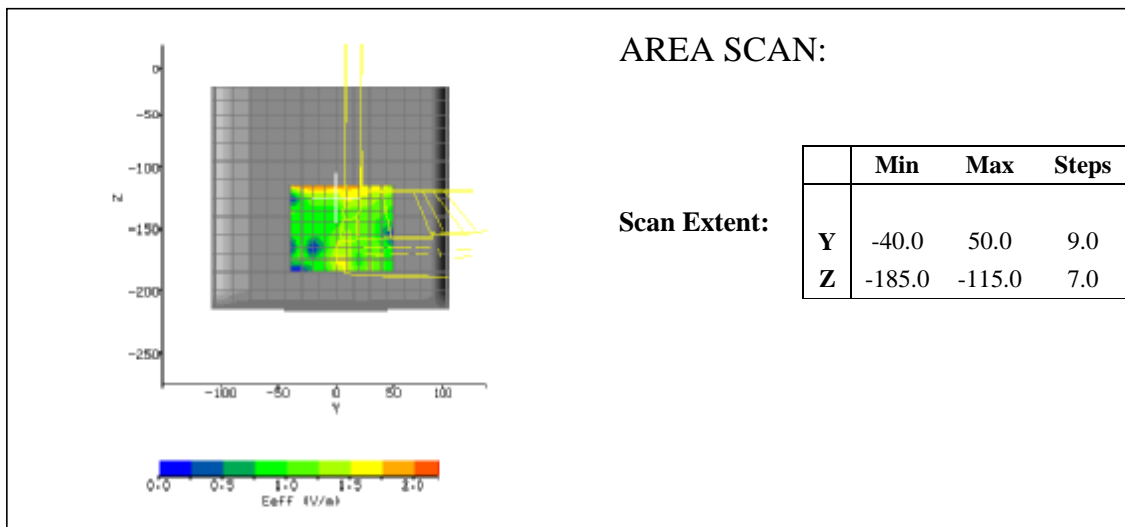

Plot #6

Date / Time: 2004/3/5	Position: right 15
Filename: 11g-MS2154-right15	Phantom: HeadBox2-test.csv
Device Tested: MS2154	Head Rotation: 0
Antenna: PIFA	Test Frequency: 2437MHz
Shape File: MS2154right.csv	Power Level: 19.193dBm

Probe: 0136 Cal File: SN0136_2450_CW_BODY <table border="1" style="margin-left: 20px;"> <thead> <tr> <th></th> <th>X</th> <th>Y</th> <th>Z</th> </tr> </thead> <tbody> <tr> <td>Air</td> <td>490</td> <td>405</td> <td>405</td> </tr> <tr> <td>DCP</td> <td>20</td> <td>20</td> <td>20</td> </tr> <tr> <td>Lin</td> <td>.405</td> <td>.405</td> <td>.405</td> </tr> </tbody> </table> Amp Gain: 2 Averaging: 1 Batteries Replaced: 1		X	Y	Z	Air	490	405	405	DCP	20	20	20	Lin	.405	.405	.405	Liquid: 15.5cm Type: 2450MHz Body Conductivity: 1.9344 Relative Permittivity: 51.1433 Liquid Temp (deg C): 22 Ambient Temp (deg C): 20 Ambient RH (%): 40 Density (kg/m3): 1000 Software Version: 2.2VPM Crest Factor=1
	X	Y	Z														
Air	490	405	405														
DCP	20	20	20														
Lin	.405	.405	.405														

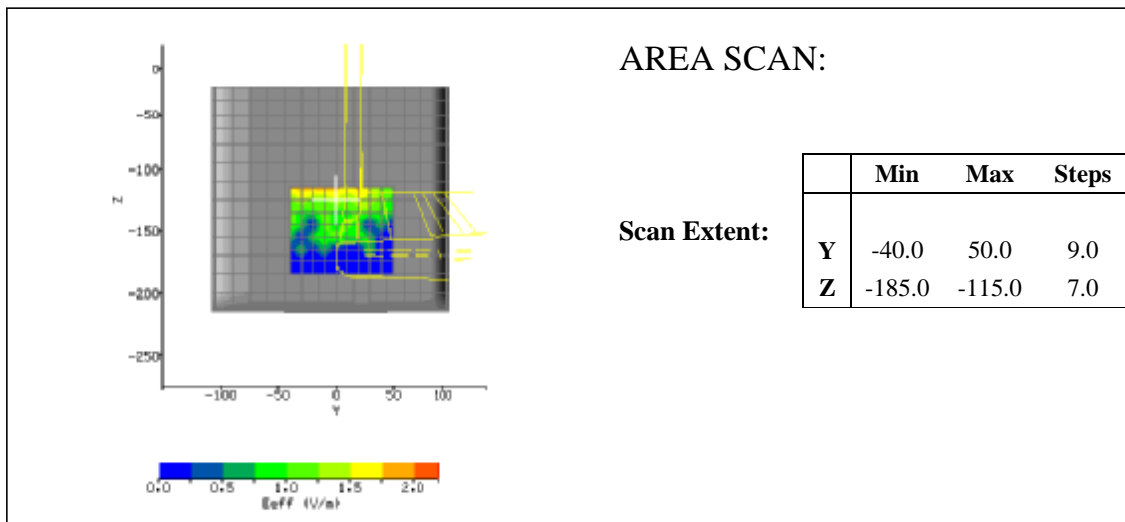

Plot #7/1

Date / Time: 2004/3/5	Position: rear 0mm
Filename: 11g-2437rear0.txt	Phantom: HeadBox2-test.csv
Device Tested: MS2154	Head Rotation: 180
Antenna: PIFA	Test Frequency: 2437Mhz
Shape File: MS2154rear.csv	Power Level: 19.193 dBm

Probe:	0136																
Cal File:	SN0136_2450_CW_BODY																
Cal Factors:	<table border="1" style="width: 100%; border-collapse: collapse;"> <thead> <tr> <th></th> <th>X</th> <th>Y</th> <th>Z</th> </tr> </thead> <tbody> <tr> <td>Air</td> <td>490</td> <td>405</td> <td>405</td> </tr> <tr> <td>DCP</td> <td>20</td> <td>20</td> <td>20</td> </tr> <tr> <td>Lin</td> <td>.405</td> <td>.405</td> <td>.405</td> </tr> </tbody> </table>		X	Y	Z	Air	490	405	405	DCP	20	20	20	Lin	.405	.405	.405
		X	Y	Z													
	Air	490	405	405													
	DCP	20	20	20													
Lin	.405	.405	.405														
Amp Gain:	2																
Averaging:	1																
Batteries Replaced:	-																

Liquid:	15.5cm
Type:	2450MHz Body
Conductivity:	1.9344
Relative Permittivity:	51.1433
Liquid Temp (deg C):	22.1
Ambient Temp (deg C):	22
Ambient RH (%):	50
Density (kg/m3):	1000
Software Version:	2.2 VPM
Crest Factor=1	

ZOOM SCAN RESULTS:

Spot SAR (W/kg):	Start Scan	End Scan
	0.159	0.158
Change during Scan (%)	-0.90	
Max E-field (V/m):	14.82	
Max SAR (W/kg)	1g	10g
	0.327	0.208
Location of Max (mm):	X	Y
	75.5	-13.0
	Z	-147.9

Plot #7/2

AREA SCAN:

Scan Extent:

	Min	Max	Steps
Y	-40.0	40.0	8.0
Z	-185.0	-135.0	5.0

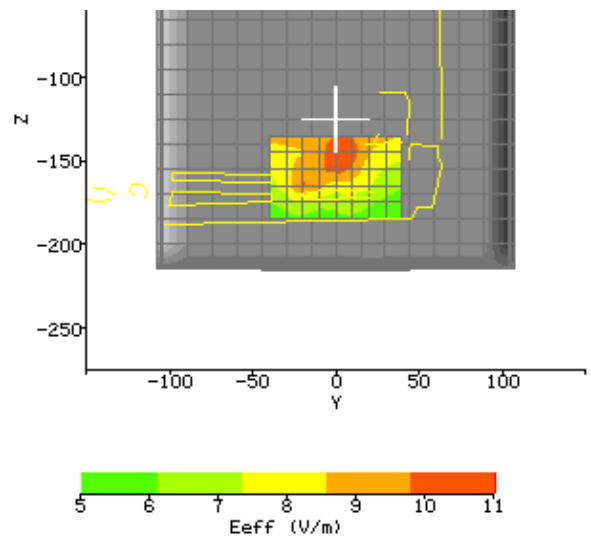

Plot #8

Date / Time: 2004/3/5	Position: rear 15mm
Filename: 11g-2437rear15a.txt	Phantom: HeadBox2-test.csv
Device Tested: MS2154	Head Rotation: 180
Antenna: PIFA	Test Frequency: 2437Mhz
Shape File: MS2154rear.csv	Power Level: 19.193 dBm

Probe:	0136			
Cal File:	SN0136_2450_CW_BODY			
Cal Factors:		X	Y	Z
	Air	490	405	405
	DCP	20	20	20
	Lin	.405	.405	.405
Amp Gain:	2			
Averaging:	1			
Batteries Replaced:	-			

Liquid:	15.5cm
Type:	2450MHz Body
Conductivity:	1.9344
Relative Permittivity:	51.1433
Liquid Temp (deg C):	22.1
Ambient Temp (deg C):	22
Ambient RH (%):	50
Density (kg/m3):	1000
Software Version:	2.2 VPM
Crest Factor=1	

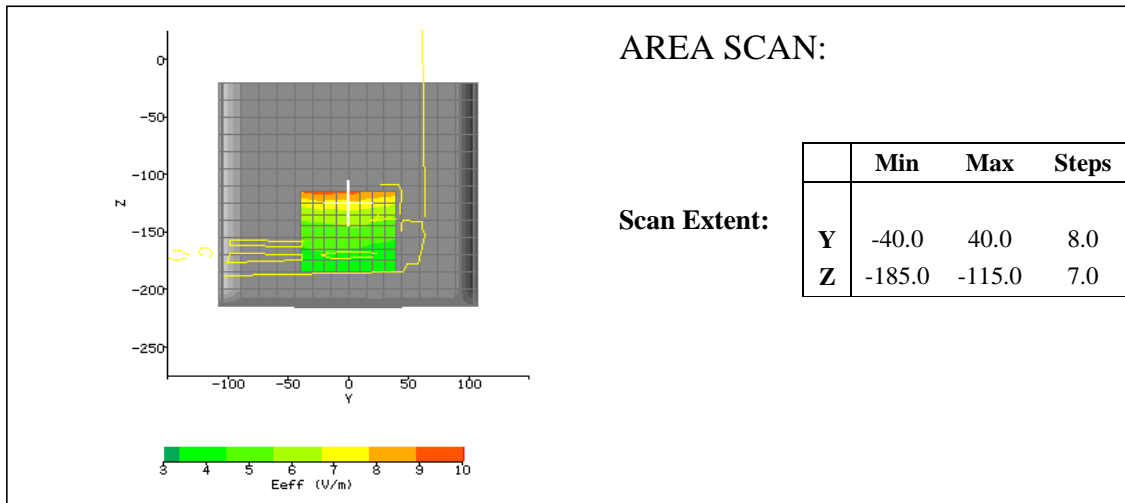

Plot #9

Date / Time: 2004/3/5	Position: bottom
Filename: 11g-2437bota.txt	Phantom: HeadBox2-test.csv
Device Tested: MS2154	Head Rotation: 180
Antenna: PIFA	Test Frequency: 2437Mhz
Shape File: MS2154bot.csv	Power Level: 19.193 dBm

Probe: 0136																
Cal File: SN0136_2450_CW_BODY																
Cal Factors:																
<table border="1" style="margin-left: auto; margin-right: auto;"> <thead> <tr> <th></th> <th>X</th> <th>Y</th> <th>Z</th> </tr> </thead> <tbody> <tr> <td>Air</td> <td>490</td> <td>405</td> <td>405</td> </tr> <tr> <td>DCP</td> <td>20</td> <td>20</td> <td>20</td> </tr> <tr> <td>Lin</td> <td>.405</td> <td>.405</td> <td>.405</td> </tr> </tbody> </table>		X	Y	Z	Air	490	405	405	DCP	20	20	20	Lin	.405	.405	.405
	X	Y	Z													
Air	490	405	405													
DCP	20	20	20													
Lin	.405	.405	.405													
Amp Gain: 2																
Averaging: 1																
Batteries Replaced: -																

Liquid: 15.5cm
Type: 2450MHz Body
Conductivity: 1.9344
Relative Permittivity: 51.1433
Liquid Temp (deg C): 22.1
Ambient Temp (deg C): 22
Ambient RH (%): 50
Density (kg/m3): 1000
Software Version: 2.2 VPM
Crest Factor=1

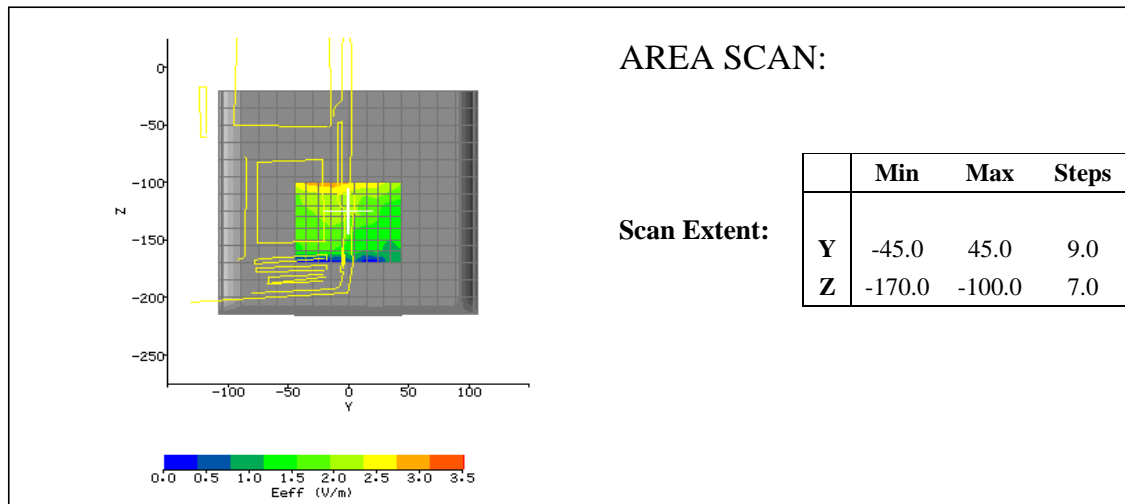

Plot #10

Date / Time: 2004/3/5	Position: right 0mm
Filename: 11g-2437right0a.txt	Phantom: HeadBox2-test.csv
Device Tested: MS2154	Head Rotation: 180
Antenna: PIFA	Test Frequency: 2437Mhz
Shape File: MS2154right.csv	Power Level: 19.193 dBm

Probe: 0136	Liquid: 15.5cm
Cal File: SN0136_2450_CW_BODY	Type: 2450MHz Body
Cal Factors:	Conductivity: 1.9344
	Relative Permittivity: 51.1433
	Liquid Temp (deg C): 22.1
	Ambient Temp (deg C): 22
Amp Gain: 2	Ambient RH (%): 50
Averaging: 1	Density (kg/m3): 1000
Batteries Replaced: -	Software Version: 2.2 VPM
	Crest Factor=1

	X	Y	Z
Air	490	405	405
DCP	20	20	20
Lin	.405	.405	.405

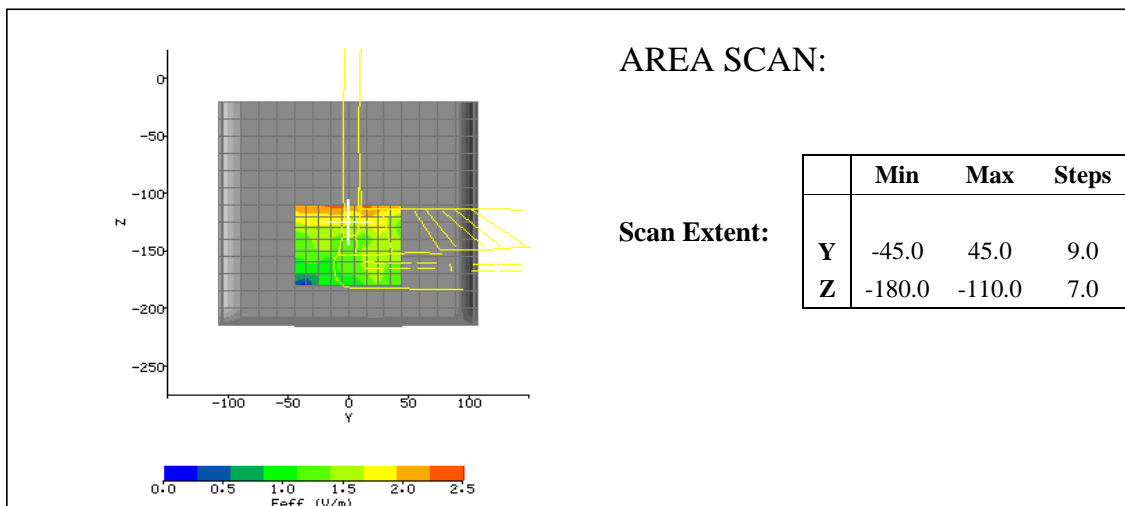

Plot #11

Date / Time: 2004/3/5	Position: right 15mm
Filename: 11g-2437right15a.txt	Phantom: HeadBox2-test.csv
Device Tested: MS2154	Head Rotation: 180
Antenna: PIFA	Test Frequency: 2437Mhz
Shape File: MS2154right.csv	Power Level: 19.193 dBm

Probe: 0136																
Cal File: SN0136_2450_CW_BODY																
Cal Factors:																
<table border="1" style="margin-left: auto; margin-right: auto;"> <thead> <tr> <th></th> <th>X</th> <th>Y</th> <th>Z</th> </tr> </thead> <tbody> <tr> <td>Air</td> <td>490</td> <td>405</td> <td>405</td> </tr> <tr> <td>DCP</td> <td>20</td> <td>20</td> <td>20</td> </tr> <tr> <td>Lin</td> <td>.405</td> <td>.405</td> <td>.405</td> </tr> </tbody> </table>		X	Y	Z	Air	490	405	405	DCP	20	20	20	Lin	.405	.405	.405
	X	Y	Z													
Air	490	405	405													
DCP	20	20	20													
Lin	.405	.405	.405													
Amp Gain: 2																
Averaging: 1																
Batteries Replaced: -																

Liquid: 15.5cm
Type: 2450MHz Body
Conductivity: 1.9344
Relative Permittivity: 51.1433
Liquid Temp (deg C): 22.1
Ambient Temp (deg C): 22
Ambient RH (%): 50
Density (kg/m3): 1000
Software Version: 2.2 VPM
Crest Factor=1

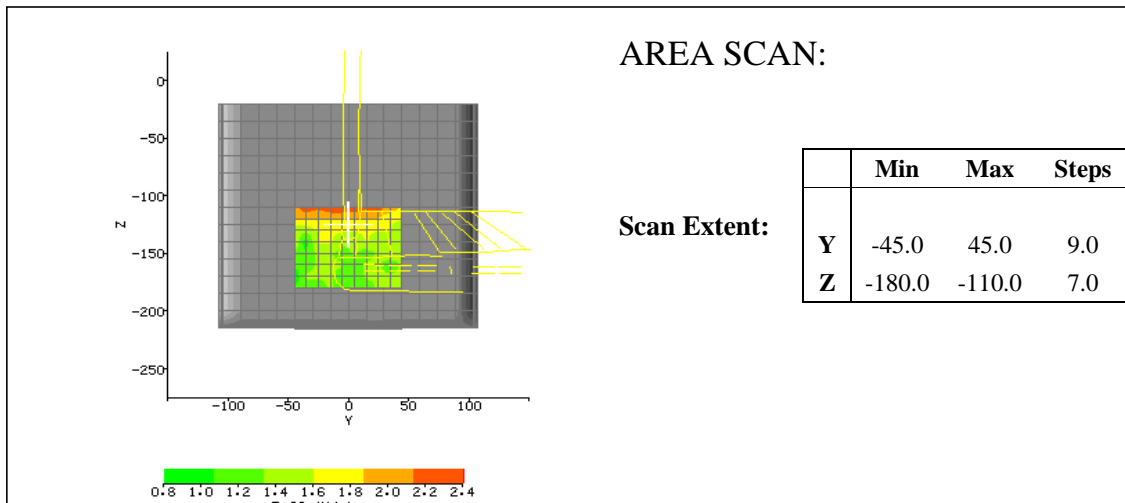

APPENDIX B - Photographs

RF Module 1



RF Module 2



RF Module 3



RF Module 4

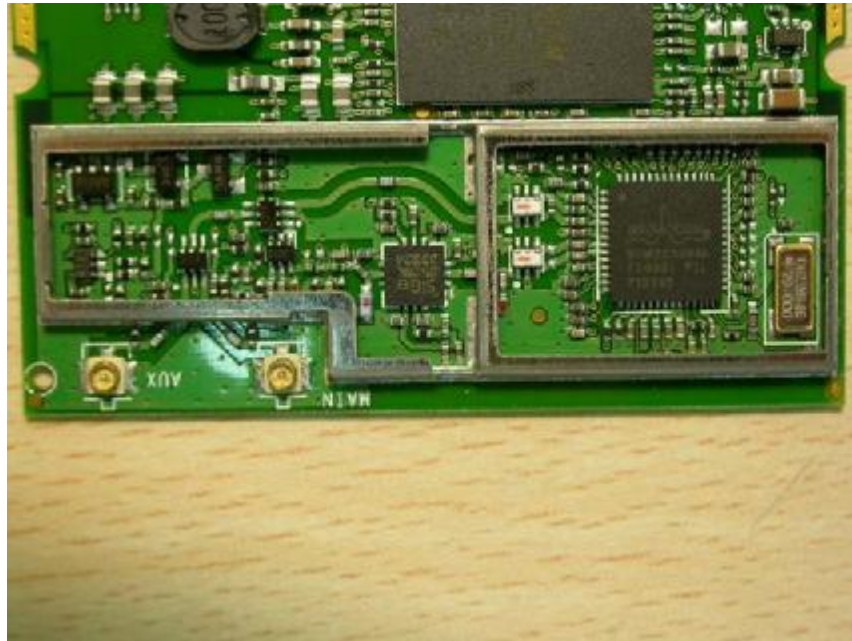

RF Module 5



RF Module 6



APPENDIX C - E-Field Probe and 2450MHz Balanced Dipole Antenna Calibration Data



IMMERSIBLE SAR PROBE

CALIBRATION REPORT

Part Number: IXP – 050

S/N 0136

10th September 2003



Indexasar Limited
Oakfield House
Cudworth Lane
Newdigate
Surrey RH5 5DR
Tel: +44 (0) 1306 631 233
Fax: +44 (0) 1306 631 834
e-mail: enquiries@indexsar.com

INTRODUCTION

This Report presents measured calibration data for a particular Indexsar SAR probe (S/N 0136) and describes the procedures used for characterisation and calibration.

Indexsar probes are characterised using procedures that, where applicable, follow the recommendations of CENELEC [1] and IEEE [2] standards. The procedures incorporate techniques for probe linearisation, isotropy assessment and determination of liquid factors (conversion factors). Calibrations are determined by comparing probe readings with analytical computations in canonical test geometries (waveguides) using normalised power inputs.

Each step of the calibration procedure and the equipment used is described in the sections below.

CALIBRATION PROCEDURE

1. Equipment Used

For the first part of the characterisation procedure, the probe is placed in an isotropy measurement jig as pictured in Figure 1. In this position the probe can be rotated about its axis by a non-metallic belt driven by a stepper motor.

The probe is attached via its amplifier and an optical cable to a PC. A schematic representation of the test geometry is illustrated in Figure 2.

A balanced dipole (900 MHz) is inserted horizontally into the bracket attached to a second belt (Figure 1). The dipole can also be rotated about its axis. A cable connects the dipole to a signal generator, via a directional coupler and power meter. The signal generator feeds an RF amplifier at constant power, the output of which is monitored using the power meter. The probe is positioned so that its sensors line up with the rotation center of the source dipole. By recording output voltage measurements of each channel as both the probe and the dipole are rotated, data are obtained from which the spherical isotropy of the probe can be optimised and its magnitude determined.

The calibration process requires E-field measurements to be taken in air, in 900 MHz simulated brain liquid and at other frequencies/liquids as appropriate.

2. Linearising probe output

The probe channel output signals are linearised in the manner set out in Refs [1] and [2]. The following equation is utilized for each channel:

$$U_{lin} = U_{o/p} + U_{o/p}^2 / DCP \quad (1)$$

where U_{lin} is the linearised signal, $U_{o/p}$ is the raw output signal in voltage units and DCP is the diode compression potential in similar voltage units.

DCP is determined from fitting equation (1) to measurements of U_{lin} versus source feed power over the full dynamic range of the probe. The DCP is a characteristic of the schottky diodes used as the sensors. For the IXP-050 probes with CW signals the DCP values are typically 0.10V (or 20 in the voltage units used by Indexsar software, which are $V*200$).

3. Selecting channel sensitivity factors to optimise isotropic response

The basic measurements obtained using the calibration jig (Fig 1) represent the output from each diode sensor as a function of the presentation angle of the source (probe and dipole rotation angles). The directionality of the orthogonally-arranged sensors can be checked by analysing the data using dedicated Indexsar software, which displays the data in 3D format as in Figure 3. The left-hand side of this diagram shows the individual channel outputs after linearisation (see above). The program uses these data to balance the channel outputs and then applies an optimisation process, which makes fine adjustments to the channel factors for optimum isotropic response.

The next stage of the process is to calibrate the Indexsar probe to a W&G EMR300 E-field meter in air. The principal reasons for this are to obtain conversion factors applicable should the probe be used in air and to provide an overall measure of the probe sensitivity.

A multiplier is applied to factors to bring the magnitudes of the average E-field measurements as close as possible to those of the W&G probe.

The following equation is used (where linearised output voltages are in units of V*200):

$$E_{air}^2 \text{ (V/m)} = U_{linx} * \text{Air Factor}_x + U_{liny} * \text{Air Factor}_y + U_{linz} * \text{Air Factor}_z \quad (2)$$

It should be noted that the air factors are not separately used for normal SAR testing. The IXP-050 probes are optimised for use in tissue-simulating liquids and do not behave isotropically in air.

4. 900 MHz Liquid Calibration

Conversion factors for use when the probes are immersed in tissue-simulant liquids at 900 MHz are determined either using a waveguide or by comparison to a reference probe that has been calibrated by NPL. Waveguide procedures are described later. The summary sheet indicates the method used for the probe S/N 0136.

The conversion factor, referred to as the ‘liquid factor’ is also applied to the measurements of each channel. The following equation is used (where output voltages are in units of V*200):

$$E_{liq}^2 \text{ (V/m)} = U_{linx} * \text{Air Factor}_x * \text{Liq Factor}_x + U_{liny} * \text{Air Factor}_y * \text{Liq Factor}_y + U_{linz} * \text{Air Factor}_z * \text{Liq Factor}_z \quad (3)$$

A 3D representation of the spherical isotropy for probe S/N 0136 using these factors is shown in Figure 3.

The rotational isotropy can also be determined from the calibration jig measurements and is reported as the 900MHz isotropy in the summary table. Note that waveguide measurements can also be used to determine rotational isotropy (Fig. 5).

The design of the cells used for determining probe conversion factors are waveguide cells is shown in Figure 4. The cells consist of a coax to waveguide transition and an open-ended section of waveguide containing a dielectric separator. Each waveguide cell stands in the upright position and is filled with liquid within 10 mm of the open end. The separator provides a liquid seal and is designed for a good electrical transition from air filled guide to liquid filled guide. The choice of cell depends on the portion of the frequency band to be examined and the choice of liquid used. The depth of liquid ensures there is negligible radiation from the waveguide open top and that the probe calibration is not influenced by

reflections from nearby objects. The return loss at the coaxial connector of the filled waveguide cell is measured initially using a network analyser and this information is used subsequently in the calibration procedure. The probe is positioned in the centre of the waveguide and is adjusted vertically or rotated using stepper motor arrangements. The signal generator is connected to the waveguide cell and the power is monitored with a coupler and a power meter. A fuller description of the waveguide method is given below.

The liquid dielectric parameters used for the probe calibrations are listed in the Tables below. The final calibration factors for the probe are listed in the summary chart.

WAVEGUIDE MEASUREMENT PROCEDURE

The calibration method is based on setting up a calculable specific absorption rate (SAR) in a vertically-mounted WG8 (R22) waveguide section [1]. The waveguide has an air-filled, launcher section and a liquid-filled section separated by a matching window that is designed to minimise reflections at the liquid interface. A TE_{01} mode is launched into the waveguide by means of a N-type-to-waveguide adapter. The power delivered to the liquid section is calculated from the forward power and reflection coefficient measured at the input to the waveguide. At the centre of the cross-section of the waveguide, the local spot SAR in the liquid as a function of distance from the window is given by functions set out in IEEE1528 as below:

Because of the low cutoff frequency, the field inside the liquid nearly propagates as a TEM wave. The depth of the medium (greater than three penetration depths) ensures that reflections at the upper surface of the liquid are negligible. The power absorbed in the liquid is determined by measuring the waveguide forward and reflected power. Equation (4) shows the relationship between the SAR at the cross-sectional center of the lossy waveguide and the longitudinal distance (z) from the dielectric separator

$$SAR(z) = \frac{4(P_f - P_b)}{rabd} e^{-2z/d} \quad (4)$$

where the density r is conventionally assumed to be 1000 kg/m^3 , ab is the cross-sectional area of the waveguide, P_f and P_b are the forward and reflected power inside the lossless section of the waveguide, respectively. The penetration depth d , which is the reciprocal of the waveguide-mode attenuation coefficient, is determined from a scan along the z -axis and compared with the theoretical value determined from Equation (5) using the measured dielectric properties of the lossy liquid.

$$d = \left[\text{Re} \left\{ \sqrt{(p/a)^2 + jwm_o(s + jwe_o e_r)} \right\} \right]^{-1} \quad (5)$$

Table A.1 of [1] can be used for designing calibration waveguides with a return loss greater than 30 dB at the most important frequencies used for personal wireless communications. Values for the penetration depth for these specific fixtures and tissue-simulating mixtures are also listed in Table A.1.

According to [1], this calibration technique provides excellent accuracy, with standard uncertainty of less than 3.6% depending on the frequency and medium. The calibration itself is reduced to power measurements traceable to a standard calibration procedure. The practical limitation to the frequency band of 800 to 2500 MHz because of the waveguide size is not severe in the context of compliance testing.

CALIBRATION FACTORS MEASURED FOR PROBE S/N 0136

The probe was calibrated at 900, 1800, 1900 and 2450MHz MHz in liquid samples representing both brain liquid and body fluid at these frequencies. The calibration was for CW signals only, and the axis of the

probe was parallel to the direction of propagation of the incident field i.e. end-on to the incident radiation. The axial isotropy of the probe was measured by rotating the probe about its axis in 10 degree steps through 360 degrees in this orientation.

The reference point for the calibration is in the centre of the probe's cross-section at a distance of 2.7 m from the probe tip in the direction of the probe amplifier. A value of 2.7 mm should be used for the tip to sensor offset distance in the software.

It is important that the diode compression point and air factors used in the software are the same as those quoted in the results tables, as these are used to convert the diode output voltages to a SAR value.

DIELECTRIC PROPERTIES OF LIQUIDS

The dielectric properties of the brain and body tissue-simulant liquids employed for calibration are listed in the tables below. The measurements were performed prior to each waveguide test using an Indexsar DiLine measurement kit, which uses the TEM method as recommended in [2].

AMBIENT CONDITIONS

Measurements were made in the open laboratory at $22 \pm 2.0^{\circ}\text{C}$. The temperature of the liquids in the waveguide used was measured using a mercury thermometer.

RESPONSE TO MODULATED SIGNALS

To measure the response of the probe and amplifier to modulated signals, the probe is held vertically in a liquid-filled waveguide.

An RF amplifier is allowed to warm up and stabilise before use. A spectrum analyser is used to demonstrate that the peak power of the RF amplifier for the CW signals and the pulsed signals are within 0.1dB of each other when the signal generator is switched from CW to modulated output. Subsequently, the power levels recorded are read from a power meter when a CW signal is being transmitted.

The test sequence involves manually stepping the power up in regular (e.g. 2 dB) steps from the lowest power that gives a measurable reading on the SAR probe up to the maximum that the amplifiers can deliver.

At each power level, the individual channel outputs from the SAR probe are recorded at CW and then recorded again with the modulation setting. The results are entered into a spreadsheet. Using the spreadsheets, the modulated power is calculated by applying a factor to the measured CW power (e.g. for GSM, this factor is 9.03dB). This process is repeated 3 times with the response maximised for each channel sensor in turn.

The probe channel output signals are linearised in the manner set out in Section 1 above using equation (1) with the DCPs determined from the linearisation procedure. Calibration factors for the probe are used to determine the E-field values corresponding to the probe readings using equation (3). SAR is determined from the equation

$$\text{SAR (W/kg)} = E_{\text{liq}}^2 \text{ (V/m)} * \sigma \text{ (S/m)} / 1000 \quad (6)$$

Where σ is the conductivity of the simulant liquid employed.

Using the spreadsheet data, the DCP value for linearising each of the individual channels (X, Y and Z) is assessed separately. The corresponding DCP values are listed in the summary page of the calibration factors for each probe.

Figure 7 shows the linearised probe response to GSM signals, Figure 8 the response to GPRS signals (GSM with 2 timeslots) and Figure 9 the response to CDMA IS-95A and W-CDMA signals.

Additional tests have shown that the modulation response is similar at 1800MHz and is not affected by the orientation between the source and the probe.

SUMMARY OF CALIBRATION FACTORS FOR PROBE IXP-050 S/N 0136

Spherical isotropy measured at 900 MHz 0.24 (+/-) dB

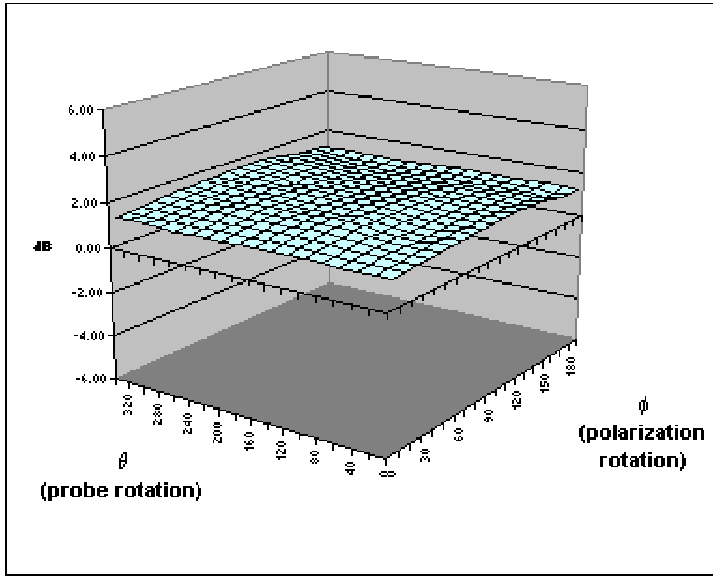

	X	Y	Z	
Air factors	490	405	405	(V*200)
DCPs	20	20	20	(V*200)
DSSS	20	20	20	(V*200)
GSM	8	9.5	11.2	(V*200)
CDMA	20	20	20	(V*200)

f (MHz)	Axial isotropy (+/- dB)		SAR conversion factors (liq/air)		Notes
	BRAIN	BODY	BRAIN	BODY	
450					
835	0.05	0.04	0.257	0.272	1,2,3
900	0.05	0.04	0.261	0.282	1,2,3
1800	0.06	0.06	0.315	0.339	1,2,3
1900	0.06	0.06	0.327	0.351	1,2,3
2450	0.05	0.10	0.378	0.405	1,2,3

Notes	
1)	Calibrations done at 22C +/- 2C
2)	Waveguide calibration
3)	Checked using box-phantom validation test

(the graph shows a simple, spreadsheet representation of surface shown in 3D in Figure 3 below)

ROBE SPECIFICATIONS

Indexsar probe 0136, along with its calibration, is compared with CENELEC and IEEE standards recommendations (Refs [1] and [2]) in the Tables below. A listing of relevant specifications is contained in the tables below:

Dimensions	S/N 0136	CENELEC [1]	IEEE [2]
Overall length (mm)	350		
Tip length (mm)	10		
Body diameter (mm)	12		
Tip diameter (mm)	5.2	8	8
Distance from probe tip to dipole centers (mm)	2.7		

Dynamic range	S/N 0136	CENELEC [1]	IEEE [2]
Minimum (W/kg)	0.01	<0.02	0.01
Maximum (W/kg) N.B. only measured to 35 W/kg	>35	>100	100

Linearity of response	S/N 0136	CENELEC [1]	IEEE [2]
Over range 0.01 – 100 W/kg (+/- dB)	0.125	0.50	0.25

Isotropy (measured at 900MHz)	S/N 0136	CENELEC [1]	IEEE [2]
Axial rotation with probe normal to source (+/- dB) at 835, 900, 1800, 1900 and 2450 MHz	Max. 0.10 (see summary table)	0.5	0.25
Spherical isotropy covering all orientations to source (+/- dB)	0.24	1.0	0.50

Construction	Each probe contains three orthogonal dipole sensors arranged on a triangular prism core, protected against static charges by built-in shielding, and covered at the tip by PEEK cylindrical enclosure material. No adhesives are used in the immersed section. Outer case materials are PEEK and heat-shrink sleeving.
Chemical resistance	Tested to be resistant to glycol and alcohol containing simulant liquids but probes should be removed, cleaned and dried when not in use.

REFERENCES

- [1] CENELEC, EN 50361, July 2001. Basic Standard for the measurement of specific absorption rate related to human exposure to electromagnetic fields from mobile phones.
- [2] IEEE 1528, Recommended practice for determining the spatial-peak specific absorption rate (SAR) in the human body due to wireless communications devices: Experimental techniques.
- [3] Calibration report on SAR probe IXP-050 S/N 0071 from National Physical Laboratory. Test Report EF07/2002/03/IndexSAR. Dated 20 February 2002.

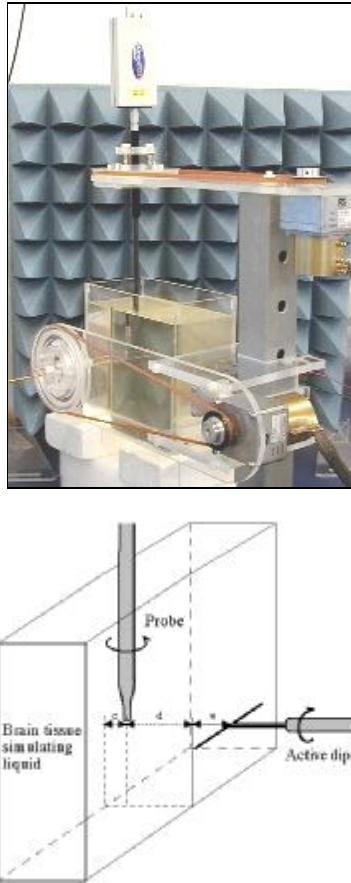

Figure 1. Spherical isotropy jig showing probe, dipole and box filled with simulated brain liquid (see Ref [2], Section A.5.2.1)

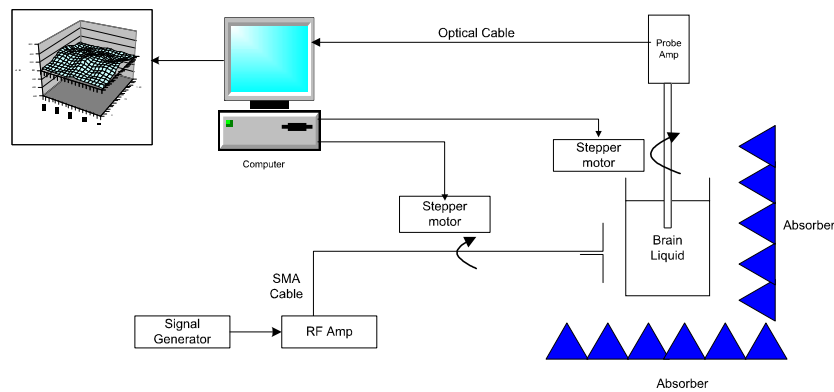

Figure 2. Schematic diagram of the test geometry used for isotropy determination

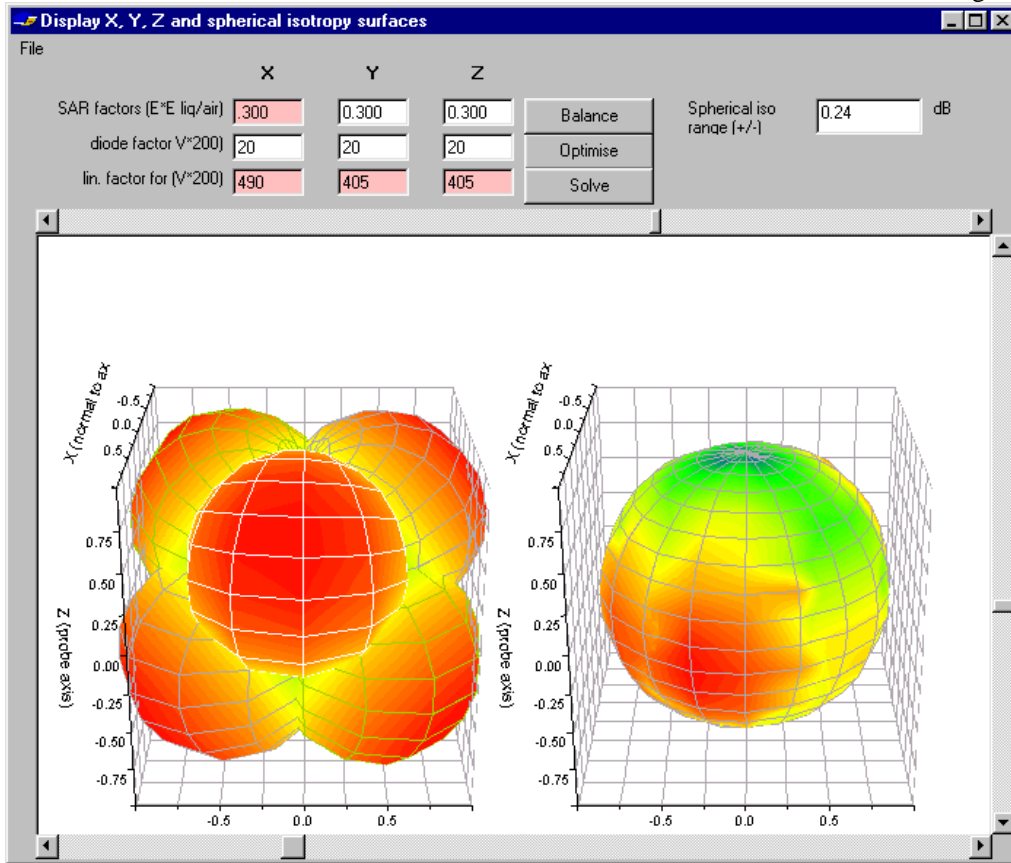

Figure 3. Graphical representation of the probe response to fields applied from each direction. The diagram on the left shows the individual response characteristics of each of the three channels and the diagram on the right shows the resulting probe sensitivity in each direction. The colour range in the figure images the lowest values as blue and the maximum values as red. For the probe S/N 0136, this range is (+/-) 0.24 dB. The probe is more sensitive to fields parallel to the axis and less sensitive to fields normal to the probe axis.

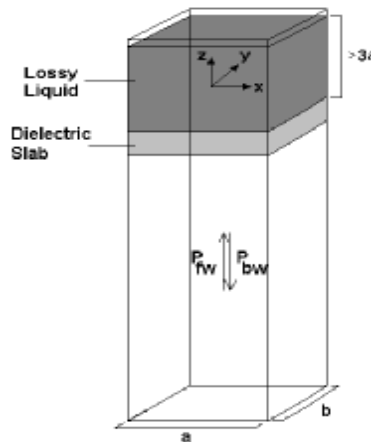

Figure 4. Geometry used for waveguide calibration (after Ref [2]. Section A.3.2.2)

IXP-050 S/N 0136

18-Aug-03

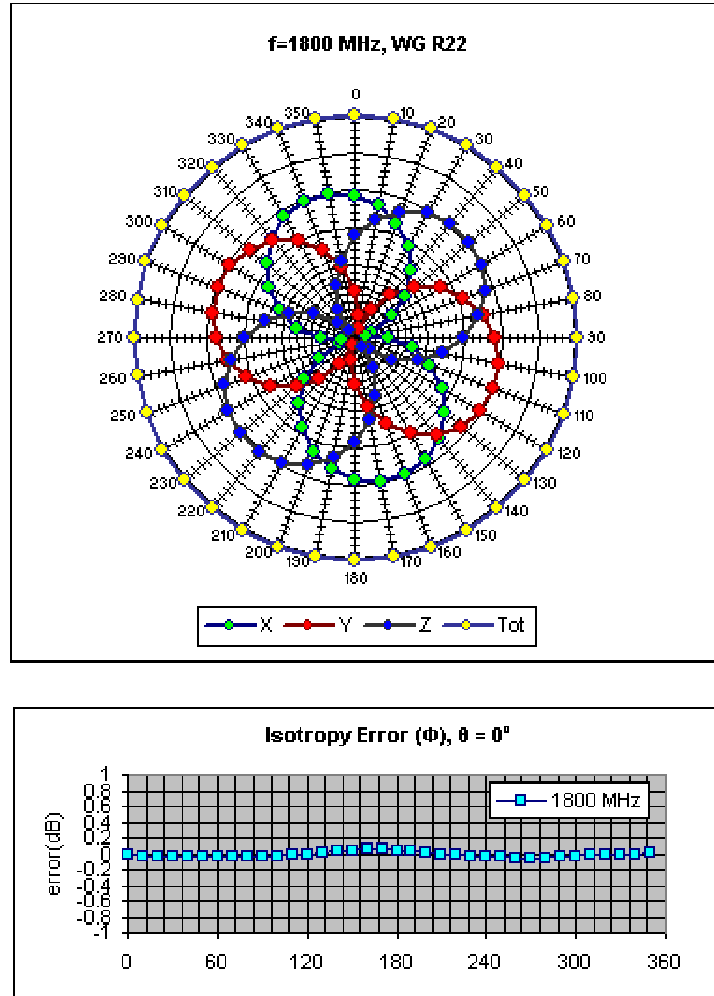

Figure 5. Example of the rotational isotropy of probe S/N 0136 obtained by rotating the probe in a liquid-filled waveguide at 2450 MHz. Similar distributions are obtained at the other test frequencies (1800 and 1900 MHz) both in brain liquids and body fluids (see summary table)

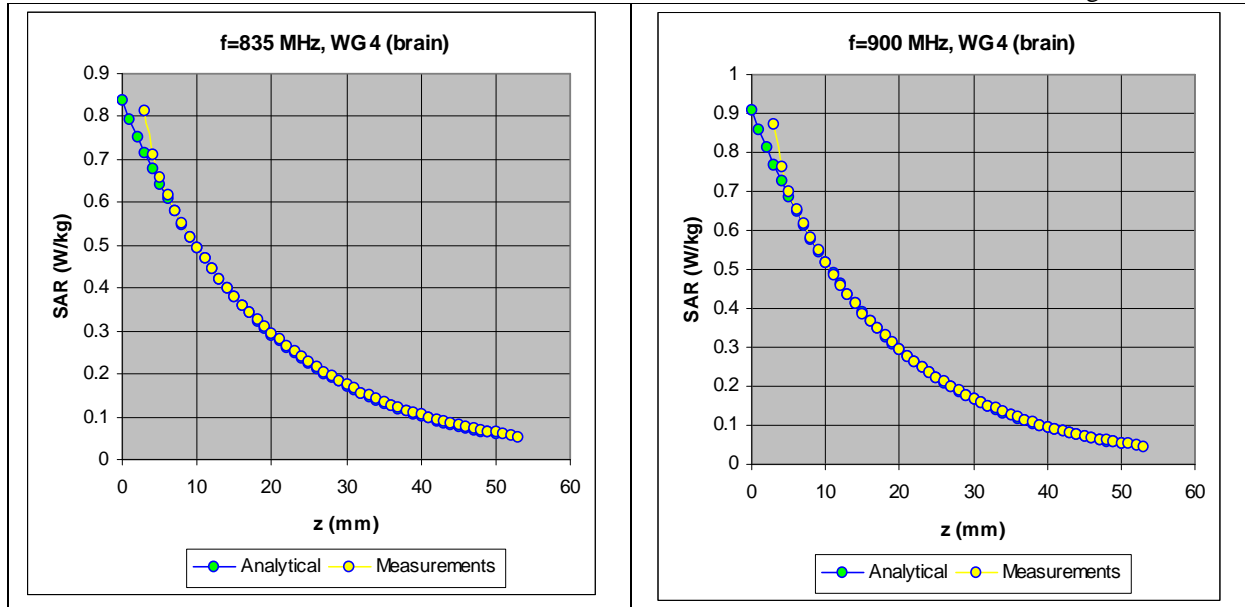

Figure 6. The measured SAR decay function along the centreline of the WG4 waveguide with conversion factors adjusted to fit to the theoretical function for the particular dimension, frequency, power and liquid properties employed.

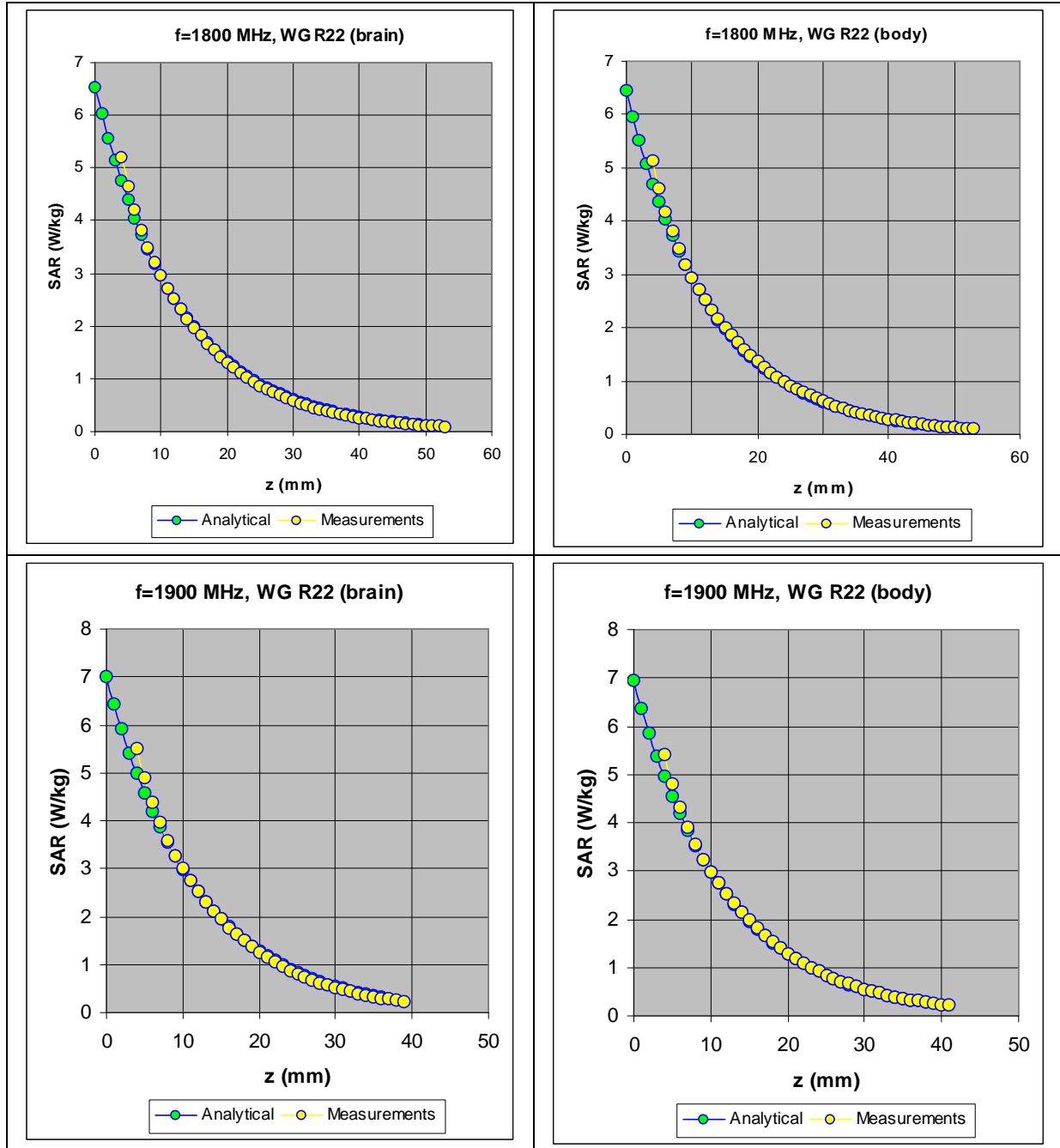

Figure 7. The measured SAR decay function along the centreline of the R22 waveguide with conversion factors adjusted to fit to the theoretical function for the particular dimension, frequency, power and liquid properties employed.

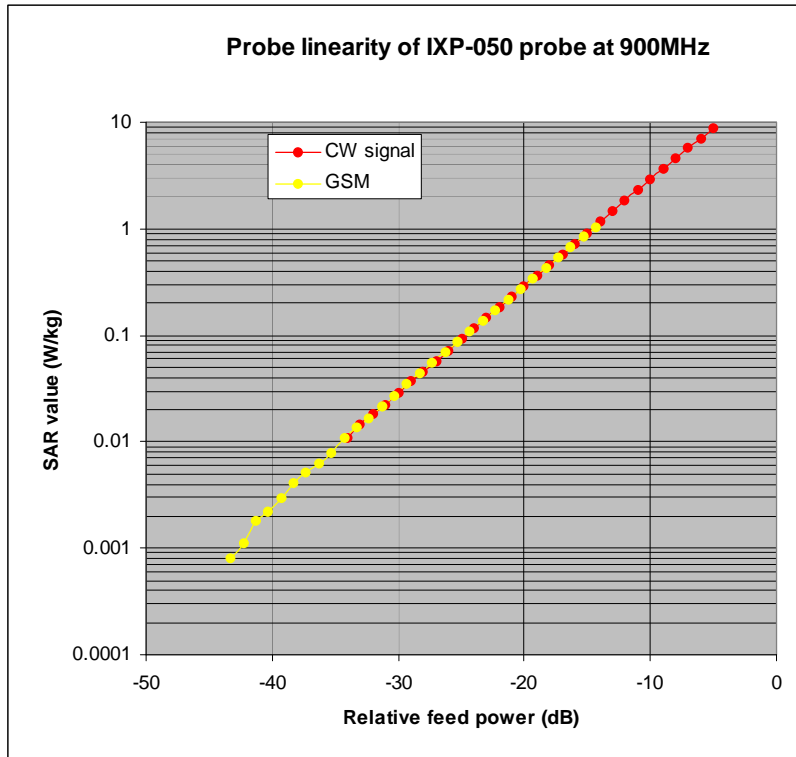

Figure 8. The GSM response of an IXP-050 probe at 900MHz.

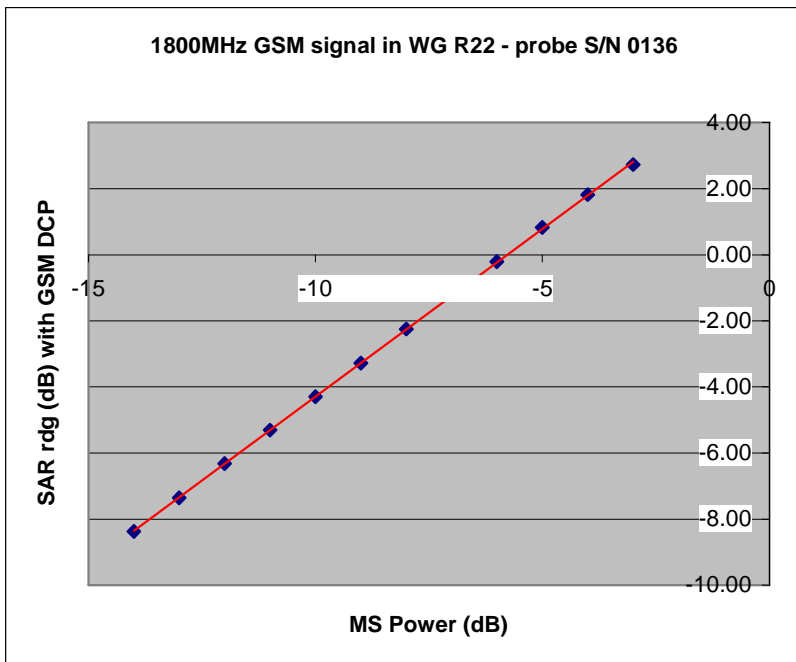

Figure 8a. The actual GSM response of IXP-050 probe S/N 0136 at 1800MHz.

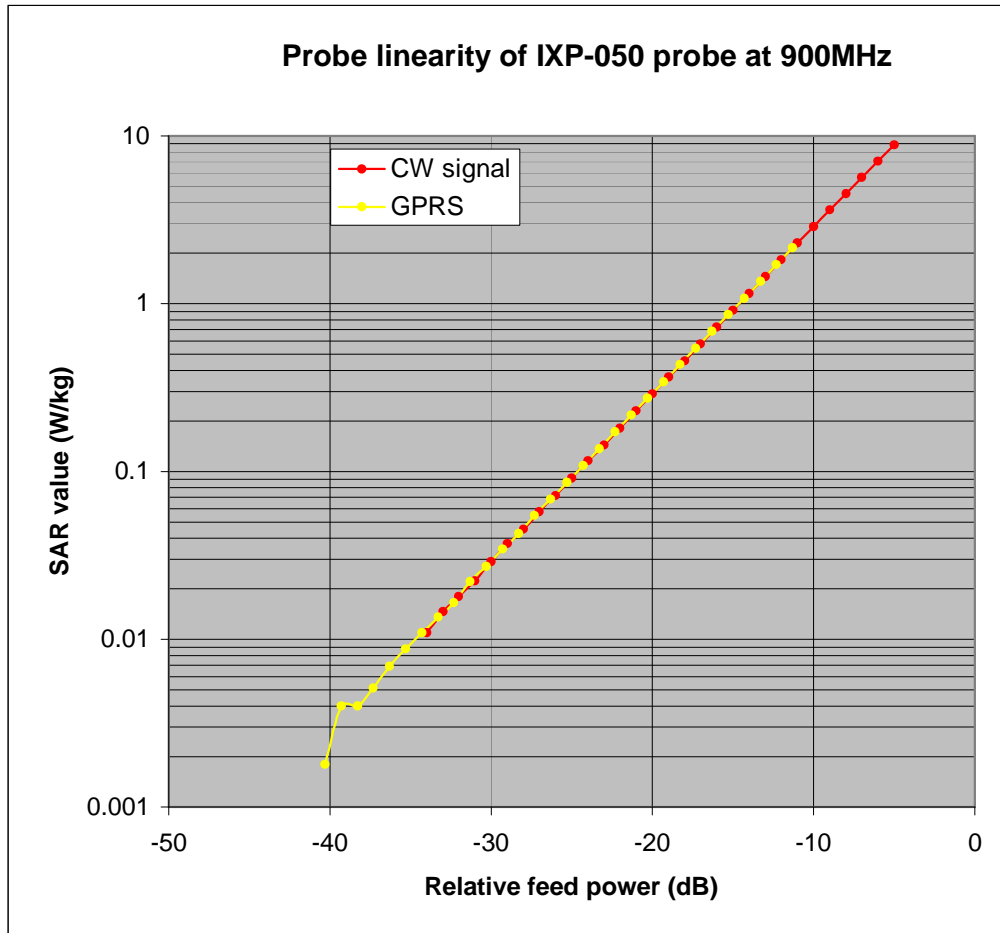

Figure 9. The GPRS response of an IXP-050 probe at 900MHz.

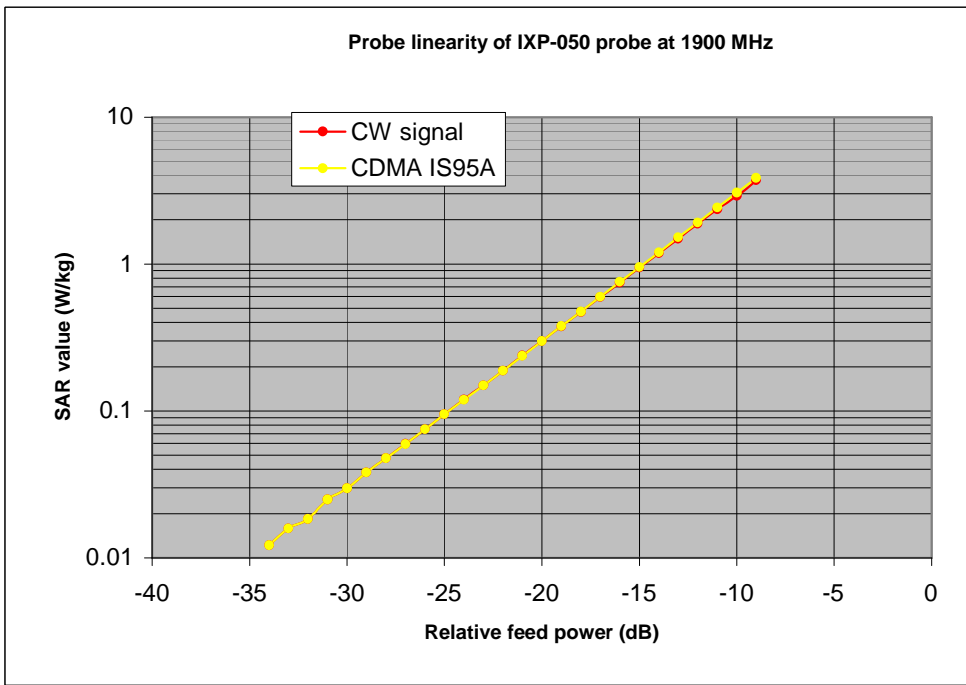
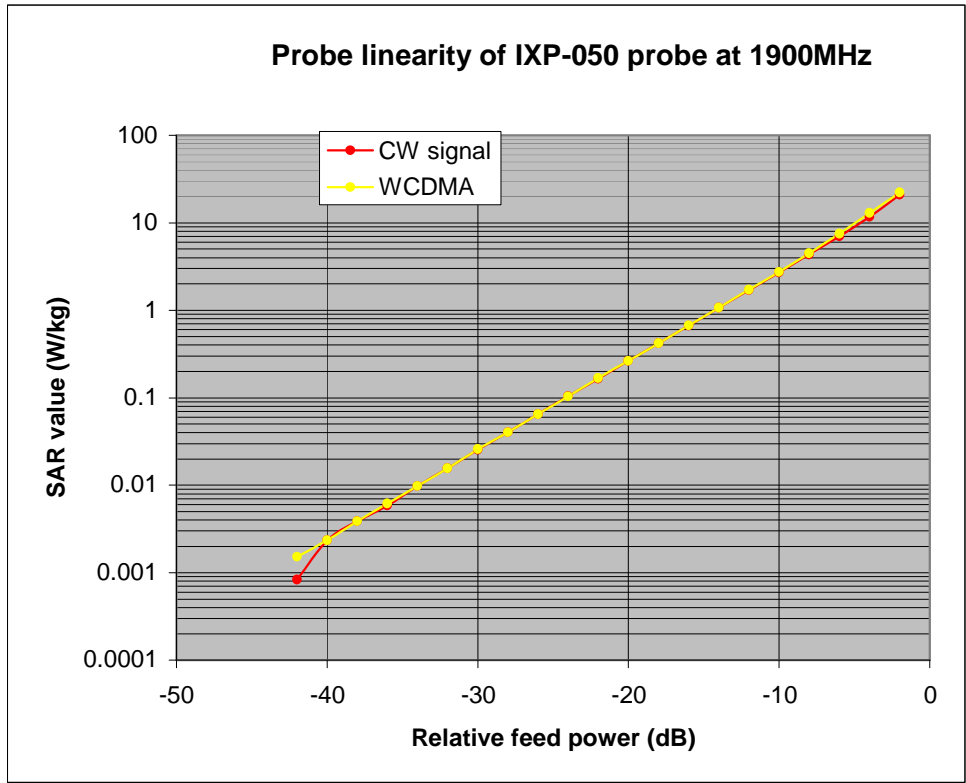

Figure 10. The CDMA response of an IXP-050 probe at 1900MHz.

Table indicating the dielectric parameters of the liquids used for calibrations at each frequency

Liquid used	Relative permittivity (measured)	Conductivity (S/m) (measured)
835 MHz BRAIN	43.18	0.935
835 MHz BODY	59.19	0.992
900 MHz BRAIN	42.47	0.998
900 MHz BODY	58.7	1.056
1800 MHz BRAIN	38.72	1.34
1800 MHz BODY	52.5	1.53
1900 MHz BRAIN	38.31	1.43
1900 MHz BODY	52.06	1.64
2450 MHz BRAIN	38.9	1.87
2450 MHz BODY	52.59	2.08



INDEXSAR
2450MHz validation Dipole
Type IXD-245 S/N 0048

Performance measurements

- *MI Manning*

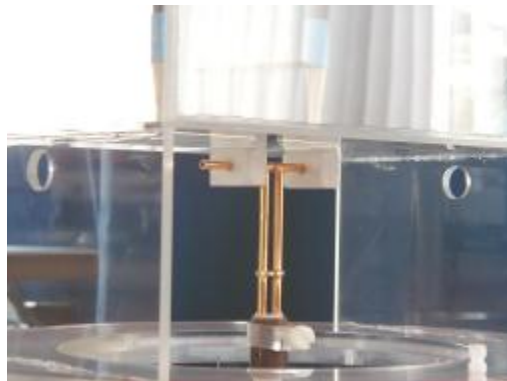

**Indexsar, Oakfield House, Cudworth Lane,
Newdigate, Surrey RH5 5DR. UK.**
Tel: +44 (0) 1306 631233 Fax: +44 (0) 1306 631834
e-mail: enquiries@indexsar.com



**Calibration / Conformance statement
Balanced Validation dipole**

Type: **IXD-245 2450MHz**

Manufacturer: **IndexSAR, UK**

Serial Number: **0048**

Place of Calibration: **IndexSAR, UK**

IndexSAR Limited hereby declares that the IXD series dipole named above has been checked for conformity to the specifications given in the draft IEEE 1528 and CENELEC En 50361 standards on the date shown below.

Date of Calibration/Check: **26th March 2003**

The dipole named above should be periodically re-checked using the procedures set out in the dipole calibration document. It is important that the cautions regarding handling of the dipoles (given in the calibration document) are adhered to.

Next Calibration Date: **March 2005**

The calibration measurements were carried out using the methods described in the calibration document. Where applicable, the standards used in the calibration process are traceable to the UK's National Physical Laboratory.

Kim Ladley
Calibrated By:

M.J. Mann
Approved By:

1. Tests on Validation Dipole

Tests have been performed on a balanced dipole made for 2450MHz application according to the construction guidelines, dimensions and tolerances given in the draft IEEE1528 standard [1]. Measurements have been made of the impedance and return loss when positioned against the liquid-filled phantom and a validation test has been performed according to the procedures set out in IEEE 1528 [1].

2. Measurement Conditions

Measurements were performed using a box-shaped phantom made of PMMA with dimensions designed to meet the accuracy criteria for reasonably-sized phantoms that do not have liquid capacities substantially in excess of the volume of liquid required to fill the Indexasar upright SAM phantoms used for SAR testing of handsets against the ear.

An HP 8753B vector network analyser was used for the return loss measurements.

The dipole was placed in a special holder made of low-permittivity, low-loss materials. This holder enables the dipole to be positioned accurately in the centre of the base of the Indexasar box-phantom used for flat-surface testing and validation checks.

The validation dipoles are supplied with special spacers made from a low-permittivity, low-loss foam material. These spacers are fitted to the dipole arms to ensure that, when the dipole is offered up to the phantom surface, the spacing between the dipole and the liquid surface is accurately aligned according to the guidance in the relevant standards documentation. The spacers are rectangular with a central hole equal to the dipole arm diameter and dimensioned so that the longer side can be used to ensure a spacing of 15mm from the liquid in the phantom (for tests at 900MHz and below) and the shorter side can be used for tests at 1800MHz and above to ensure a spacing of 10mm from the liquid in the phantom. The spacers are made on a CNC milling machine with an accuracy of $1/40^{\text{th}}$ mm but they may suffer wear and tear and need to be replaced periodically. The material used is Rohacell, which has a relative permittivity of approx. 1.05 and a negligible loss tangent.

The apparatus supplied by Indexasar for dipole validation tests thus includes:

Balanced dipoles for each frequency required are dimensioned according to the guidelines given in IEEE 1528 [1]. The dipoles are made from semi-rigid 50 Ohm co-ax, which is joined by soldering and is gold-plated subsequently. The constructed dipoles are easily deformed, if mis-handled, and periodic checks need to be made of their symmetry.

Rohacell foam spacers designed for presenting the dipoles to 2mm thick PMMA box phantoms. These components also suffer wear and tear and should be replaced when the central hole is a loose-fit on the dipole arms or if the edges are too worn to ensure accurate alignment. The standard spacers are dimensioned for use with 2mm wall thickness (additional spacers are available for 4mm wall thickness).

3. SAR Validation Measurement

A SAR validation check was performed with the box-phantom located on the SARA2 phantom support base on the SARA2 robot system. Tests were then conducted at a feed power level of approx. 0.25W. The actual power level was recorded and used to normalise the results obtained to the standard input power conditions of 1W (forward power). The ambient temperature was 24°C.

The phantom was filled with a 2450MHz brain liquid using a recipe from [1], which was measured using an Indexasar DiLine kit at 2450MHz. Measurements were taken at 23°C and 30°C and interpolation was used to find the properties at 24°C which were as below:

Relative Permittivity **39.221**

Conductivity **1.8714 S/m**

The SARA2 software version 0.420N was used with an Indexsar probe previously calibrated using waveguide techniques.

The 3D measurement made using the dipole at the bottom of the phantom box is shown below:

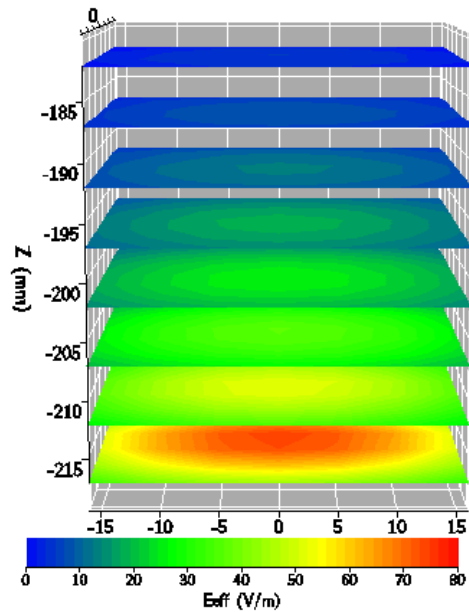

The volume-averaged SAR results, normalised to an input power of 1W (forward power) are:

Averaged over 1 cm ³ (1g) of tissue	51.376 W/kg
Averaged over 10cm ³ (10g) of tissue	23.888 W/kg

These results can be compared with Table 8.1 in [1]. The agreement is within 10%.

4. Dipole impedance and return loss

The dipoles are designed to have low return loss ONLY when presented against a lossy-phantom at the specified distance. A Vector Network Analyser (VNA) was used to perform a return loss measurement on the specific dipole when in the measurement-location against the box phantom. The distance was as specified in the standard i.e. 10mm from the liquid (for 2450MHz). The Indexsar foam spacers (described above) were used to ensure this condition during measurement.

The impedance was measured at the SMA-connector with the network analyser. The following parameters were measured:

Dipole impedance at 2450 MHz $\text{Re}\{Z\} = \mathbf{44.814 \Omega}$
 $\text{Im}\{Z\} = \mathbf{-5.3359 \Omega}$

Return loss at 2450MHz **-22.122 dB**

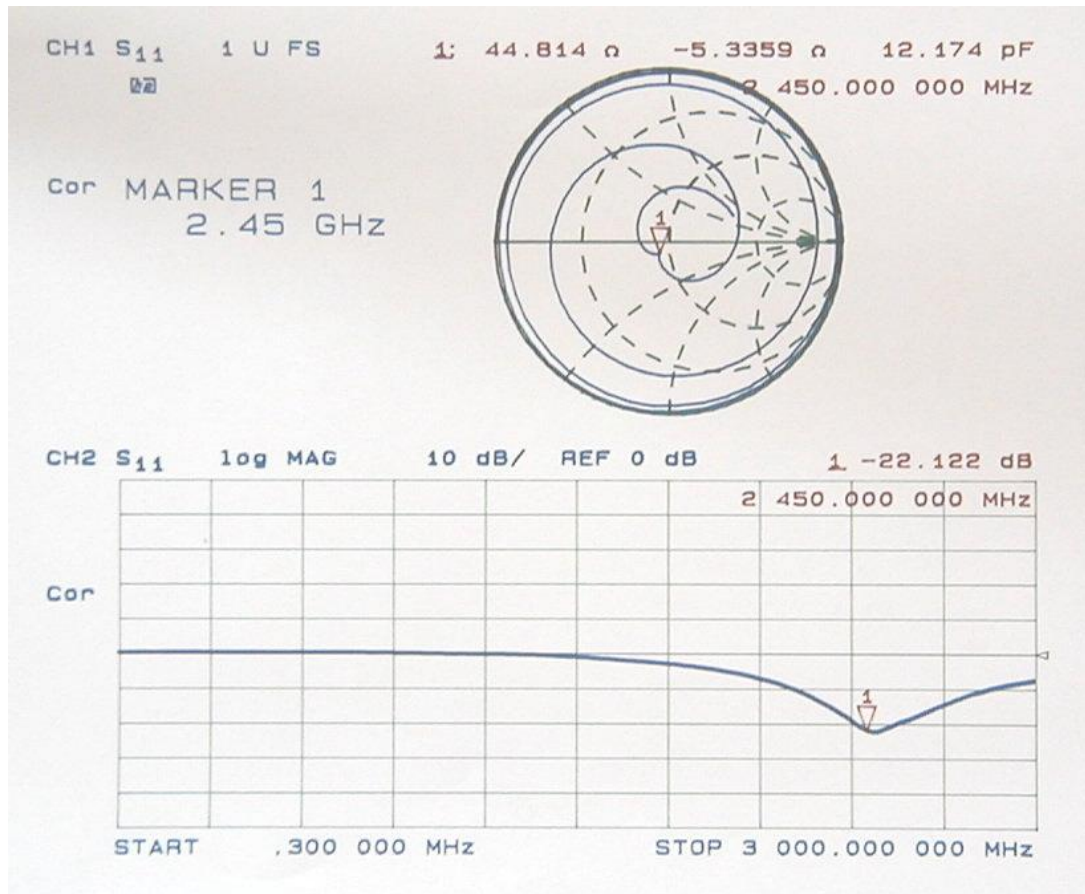

5. Dipole handling

The dipoles are made from standard, copper-sheathed coaxial cable. In assembly, the sections are joined using ordinary soft-soldering. This is necessary to avoid excessive heat input in manufacture, which would destroy the polythene dielectric used for the cable. The consequence of the construction material and the assembly technique is that the dipoles are fragile and can be deformed by rough handling. Conversely, they can be straightened quite easily as described in this report.

If a dipole is suspected of being deformed, a normal workshop lathe can be used as an alignment jig to restore the symmetry. To do this, the dipole is first placed in the headstock of the lathe (centred on the plastic or brass spacers) and the headstock is rotated by hand (do NOT use the motor). A marker (lathe tool or similar) is brought up close to the end of one dipole arm and then the headstock is rotated by 0.5 rev. to check the opposing arm. If they are not balanced, judicious deformation of the arms can be used to restore the symmetry.

If a dipole has a failed solder joint, the dipole can be fixed down in such a way that the arms are co-linear and the joint re-soldered with a reasonably-powerful electrical soldering iron. Do not use gas soldering irons. After such a repair, electrical tests must be performed as described below.

Please note that, because of their construction, the dipoles are short-circuited for DC signals.

6. Tuning the dipole

The dipole dimensions are based on calculations that assumed specific liquid dielectric properties. If the liquid dielectric properties are somewhat different, the dipole tuning will also vary. A pragmatic way of accounting for variations in liquid properties is to 'tune' the dipole (by applying minor variations to its effective length). For this purpose, Indexasar can supply short brass tube lengths to extend the length of the dipole and thus 'tune' the dipole. It cannot be made shorter without removing a bit from the arm. An alternative way to tune the dipole is to use copper shielding tape to extend the effective length of the dipole. Do both arms equally.

It should be possible to tune a dipole as described, whilst in place in the measurement position as long as the user has access to a VNA for determining the return loss.

7. Reference

[1] Draft recommended practice for determining the peak spatial-average specific absorption rate (SAR) in the human body due to wireless communications devices: Measurement Techniques. Draft CD1.1 – December 29, 2002.