

FCC RF Test Report

APPLICANT : Acer Incorporated
EQUIPMENT : Smart HandHeld
BRAND NAME : Acer
MODEL NAME : S120
FCC ID : HLZJMS120
STANDARD : FCC 47 CFR Part 2, 22(H), 24(E)
CLASSIFICATION : PCS Licensed Transmitter Held to Ear (PCE)
Tx/Rx FREQUENCY RANGE : GSM850 : 824.2 ~ 848.8 MHz /
869.2 ~ 893.8 MHz
GSM1900 : 1850.2 ~ 1909.8 MHz /
1930.2 ~ 1989.8 MHz
WCDMA Band V : 826.4 ~ 846.6 MHz /
871.4 ~ 891.6 MHz
WCDMA Band II : 1852.4 ~ 1907.6 MHz /
1932.4 ~ 1987.6 MHz
MAX. ERP/EIRP POWER : GSM850 (GSM) : 0.81 W
GSM850 (EDGE 8) : 0.41 W
GSM1900 (GSM) : 0.56 W
GSM1900 (EDGE 8) : 0.40 W
WCDMA Band V (RMC 12.2Kbps) : 0.10 W
WCDMA Band II (RMC 12.2Kbps) : 0.12 W
EMISSION DESIGNATOR : GMSK : 246KGXW
8PSK : 248KG7W
QPSK : 4M16F9W

The product was received on Aug. 19, 2010 and completely tested on Oct. 20, 2010. We, SPORTON INTERNATIONAL INC., would like to declare that the tested sample has been evaluated in accordance with the procedures given in ANSI / TIA / EIA-603-C-2004 and shown compliance with the applicable technical standards.

The test results in this report apply exclusively to the tested model / sample. Without written approval of SPORTON INTERNATIONAL INC., the test report shall not be reproduced except in full.

Reviewed by:



Anderson Chiu / Deputy Manager



SPORTON INTERNATIONAL INC.

No. 52, Hwa Ya 1st Rd., Hwa Ya Technology Park, Kwei-Shan Hsiang, Tao Yuan Hsien, Taiwan, R.O.C.

SPORTON INTERNATIONAL INC.

TEL : 886-3-327-3456

FAX : 886-3-328-4978

FCC ID : HLZJMS120

Page Number : 1 of 70

Report Issued Date : Oct. 20, 2010

Report Version : Rev. 01



TABLE OF CONTENTS

REVISION HISTORY..... 3
SUMMARY OF TEST RESULT 4
1 GENERAL DESCRIPTION 5
1.1 Applicant..... 5
1.2 Manufacturer 5
1.3 Feature of Equipment Under Test..... 6
1.4 Testing Site..... 7
1.5 Applied Standards 7
1.6 Ancillary Equipment List 7
2 TEST CONFIGURATION OF EQUIPMENT UNDER TEST 8
2.1 Test Mode..... 8
2.2 Connection Diagram of Test System 9
3 TEST RESULT 10
3.1 Conducted Output Power Measurement 10
3.2 Effective Radiated Power and Effective Isotropic Radiated Power Measurement 12
3.3 Occupied Bandwidth Measurement 18
3.4 Band Edge Measurement..... 25
3.5 Conducted Emission Measurement 32
3.6 Field Strength of Spurious Radiation Measurement 48
3.7 Frequency Stability Measurement..... 62
4 LIST OF MEASURING EQUIPMENT 69
5 UNCERTAINTY OF EVALUATION 70
APPENDIX A. PHOTOGRAPHS OF EUT
APPENDIX B. SETUP PHOTOGRAPHS



REVISION HISTORY

| REPORT NO. | VERSION | DESCRIPTION | ISSUED DATE |
|-------------------|----------------|-------------------------|--------------------|
| FG081915-02 | Rev. 01 | Initial issue of report | Oct. 20, 2010 |
| | | | |
| | | | |
| | | | |
| | | | |
| | | | |
| | | | |
| | | | |
| | | | |
| | | | |
| | | | |
| | | | |
| | | | |
| | | | |
| | | | |
| | | | |



SUMMARY OF TEST RESULT

| Report Section | FCC Rule | IC Rule | Description | Limit | Result | Remark |
|----------------|-------------------------------------|------------------------------------|---|-------------------------------------|--------|--|
| 3.1 | §2.1046 | N/A | Conducted Output Power | N/A | PASS | - |
| 3.2 | §22.913(a)(2) | RSS-132(4.4) SRSP-503(5.1.3) | Effective Radiated Power | < 7 Watts | PASS | - |
| 3.2 | §24.232(c) | RSS-133 (6.4) SRSP-510(5.1.2) | Equivalent Isotropic Radiated Power | < 2 Watts | PASS | - |
| 3.3 | §2.1049 §22.917(a) §24.238(a) | N/A | Occupied Bandwidth | N/A | PASS | - |
| 3.4 | §2.1051 §22.917(a) §24.238(a) | RSS-132 (4.5.1) RSS-133 (6.5.1) | Band Edge Measurement | < 43+10log ₁₀ (P[Watts]) | PASS | - |
| 3.5 | §2.1051 §22.917(a) §24.238(a) | RSS-132 (4.5.1) RSS-133 (6.5.1) | Conducted Emission | < 43+10log ₁₀ (P[Watts]) | PASS | - |
| 3.6 | §2.1053 §22.917(a) §24.238(a) | RSS-132 (4.5.1) RSS-133 (6.5.1) | Field Strength of Spurious Radiation | < 43+10log ₁₀ (P[Watts]) | PASS | Under limit 19.21 dB at 11280.00 MHz |
| 3.7 | §2.1055 §22.355 §24.235 | RSS-132(4.3) RSS-133(6.3) | Frequency Stability for Temperature & Voltage | < 2.5 ppm | PASS | - |



1 General Description

1.1 Applicant

Acer Incorporated

8F., No. 88, Sec. 1, Hsin Tai Wu Rd., Hsichih, Taipei Hsien 221, Taiwan

1.2 Manufacturer

Compal Communication (Nanjing)

Nanjing Jingning Export Processing Zone (South Area) No. 68-2 Suyuan Street

1.3 Feature of Equipment Under Test

| Product Feature & Specification | |
|---------------------------------|---|
| Equipment | Smart HandHeld |
| Brand Name | Acer |
| Model Name | S120 |
| Sample 1 | EUT with Memory 1 |
| Sample 2 | EUT with Memory 2 |
| FCC ID | HLZJMS120 |
| Tx Frequency | GSM850 : 824 MHz ~ 849 MHz GSM1900 : 1850 MHz ~ 1910 MHz WCDMA Band V : 824 MHz ~ 849 MHz WCDMA Band II : 1850 MHz ~ 1910 MHz |
| Rx Frequency | GSM850 : 869 MHz ~ 894 MHz GSM1900 : 1930 MHz ~ 1990 MHz WCDMA Band V : 869 MHz ~ 894 MHz WCDMA Band II : 1930 MHz ~ 1990 MHz |
| Maximum Output Power to Antenna | GSM850 : 33.58 dBm GSM1900 : 30.56 dBm WCDMA Band V : 23.29 dBm WCDMA Band II : 23.39 dBm |
| Maximum ERP/EIRP | GSM850 (GSM) : 0.81 W (29.08 dBm) GSM850 (EDGE 8) : 0.41 W (26.10 dBm) GSM1900 (GSM) : 0.56 W (27.51 dBm) GSM1900 (EDGE 8) : 0.40 W (26.02 dBm) WCDMA Band V (RMC 12.2Kbps) : 0.10 W (20.04 dBm) WCDMA Band II (RMC 12.2Kbps) : 0.12 W (20.81 dBm) |
| Antenna Type | Fixed Internal Antenna |
| HW Version | REV0E (DVT2) |
| SW Version | Android version: 2.2 Baseband version: A4-00.18.00 Build number:Acer_LiquidMetal_0.018.50 |
| Type of Modulation | GSM / GPRS : GMSK EDGE : 8PSK WCDMA : QPSK HSDPA : QPSK / 16QAM HSUPA : BPSK |
| Type of Emission | GMSK : 246KGXW 8PSK : 248KG7W QPSK : 4M16F9W |
| EUT Stage | Identical Prototype |

Remark:

1. For other wireless features of this EUT, the test report will be issued separately.
2. This test report recorded only product characteristics and test results of PCS Licensed Transmitter Held to Ear (PCE).
3. The above EUT's information was declared by manufacturer. Please refer to the specifications or user's manual for more detailed description.

1.4 Testing Site

| | | | |
|---------------------------|---|-----------|--------------------------------|
| Test Site | SPORTON INTERNATIONAL INC. | | |
| Test Site Location | No. 52, Hwa Ya 1 st Rd., Hwa Ya Technology Park, Kwei-Shan Hsiang, Tao Yuan Hsien, Taiwan, R.O.C. TEL: +886-3-327-3456 FAX: +886-3-328-4978 | | |
| Test Site No. | Sporton Site No. | | FCC/IC Registration No. |
| | TH02-HY | 03CH07-HY | TW1022/4086B-1 |

1.5 Applied Standards

According to the specifications of the manufacturer, the EUT must comply with the requirements of the following standards:

- ♦ Preliminary Guidance for Receiving Applications for Certification of 3G Device. May 9, 2006.
- ♦ FCC 47 CFR Part 2, 22(H), 24(E)
- ♦ ANSI / TIA / EIA-603-C-2004
- ♦ IC RSS-132 Issue 2
- ♦ IC RSS-133 Issue 5

Remark:

1. All test items were verified and recorded according to the standards and without any deviation during the test.
2. This EUT has also been tested and complied with the requirements of FCC Part 15, Subpart B (DoC), recorded in a separate test report.

1.6 Ancillary Equipment List

| Item | Equipment | Trade Name | Model No. | FCC ID | Data Cable | Power Cord |
|------|------------------|------------|-----------|--------|------------|-------------------|
| 1. | System Simulator | R&S | CMU200 | N/A | N/A | Unshielded, 1.8 m |

2 Test Configuration of Equipment Under Test

2.1 Test Mode

During all testing, EUT is in link mode with base station emulator at maximum power level. The spurious emission measurements were carried out in semi-anechoic chamber with 3-meter test range, and EUT is rotated on three test planes to find out the worst emission.

Frequency range investigated for radiated emission is as follows:

1. 30 MHz to 9000 MHz for GSM850 and WCDMA Band V.
2. 30 MHz to 19000 MHz for GSM1900 and WCDMA Band II.

| Test Modes | | |
|---------------|---|---|
| Band | Radiated TCs | Conducted TCs |
| GSM 850 | <ul style="list-style-type: none"> ■ GSM Link ■ EDGE 8 Link | <ul style="list-style-type: none"> ■ GSM Link ■ EDGE 8 Link |
| GSM 1900 | <ul style="list-style-type: none"> ■ GSM Link ■ EDGE 8 Link | <ul style="list-style-type: none"> ■ GSM Link ■ EDGE 8 Link |
| WCDMA Band V | <ul style="list-style-type: none"> ■ RMC 12.2Kbps Link | <ul style="list-style-type: none"> ■ RMC 12.2Kbps Link |
| WCDMA Band II | <ul style="list-style-type: none"> ■ RMC 12.2Kbps Link | <ul style="list-style-type: none"> ■ RMC 12.2Kbps Link |

Note:

1. The maximum power levels are GSM mode for GMSK link, EDGE multi-slot class 8 mode for 8PSK link, RMC 12.2Kbps mode for WCDMA band V and WCDMA band II, only these modes were used for all tests.
2. Because there are individual antennas for each WWAN, WLAN, and Bluetooth, the co-location test modes are not required.
3. Sample 1 and Sample 2 are almost the same. The difference between these two samples is memory only. The difference is not related any RF effect, so only Sample 1 is used for all tests.

The conducted power tables are as follows:

| Conducted Power (*Unit: dBm) | | | | | | |
|------------------------------|--------|-------|-------|---------|--------|--------|
| Band | GSM850 | | | GSM1900 | | |
| Channel | 128 | 189 | 251 | 512 | 661 | 810 |
| Frequency | 824.2 | 836.4 | 848.8 | 1850.2 | 1880.0 | 1909.8 |
| GSM | 33.58 | 33.57 | 33.46 | 30.56 | 30.49 | 30.45 |
| GPRS 8 | 33.28 | 33.33 | 33.23 | 30.43 | 30.47 | 30.46 |
| GPRS 10 | 33.16 | 33.14 | 33.02 | 30.35 | 30.28 | 30.26 |
| GPRS 12 | 32.64 | 32.45 | 32.48 | 29.81 | 29.76 | 29.82 |
| EGPRS 8 | 26.95 | 26.97 | 26.99 | 24.97 | 24.85 | 24.94 |
| EGPRS 10 | 26.71 | 26.70 | 26.74 | 24.93 | 24.80 | 24.82 |
| EGPRS 12 | 26.21 | 26.17 | 26.16 | 24.53 | 24.38 | 24.32 |

| Conducted Power (*Unit: dBm) | | | | | | |
|------------------------------|--------------|--------------|-------|---------------|--------------|--------|
| Band | WCDMA Band V | | | WCDMA Band II | | |
| Channel | 4132 | 4182 | 4233 | 9262 | 9400 | 9538 |
| Frequency | 826.4 | 836.4 | 846.6 | 1852.4 | 1880.0 | 1907.6 |
| RMC 12.2K | 22.77 | 23.29 | 22.79 | 23.06 | 23.39 | 22.92 |
| HSDPA Subtest-1 | 22.20 | 22.68 | 22.53 | 22.65 | 22.80 | 22.37 |
| HSDPA Subtest-2 | 22.16 | 22.72 | 22.54 | 22.68 | 22.89 | 22.38 |
| HSDPA Subtest-3 | 21.78 | 22.23 | 22.03 | 22.19 | 22.48 | 21.97 |
| HSDPA Subtest-4 | 21.76 | 22.15 | 21.99 | 22.14 | 22.37 | 21.95 |
| HSUPA Subtest-1 | 21.85 | 22.66 | 22.53 | 22.04 | 22.50 | 22.20 |
| HSUPA Subtest-2 | 20.53 | 21.16 | 21.25 | 21.08 | 21.26 | 21.02 |
| HSUPA Subtest-3 | 20.93 | 21.62 | 21.77 | 21.54 | 21.74 | 21.89 |
| HSUPA Subtest-4 | 20.85 | 21.40 | 21.21 | 21.25 | 21.58 | 20.95 |
| HSUPA Subtest-5 | 21.91 | 22.66 | 22.59 | 22.82 | 22.33 | 22.16 |

2.2 Connection Diagram of Test System

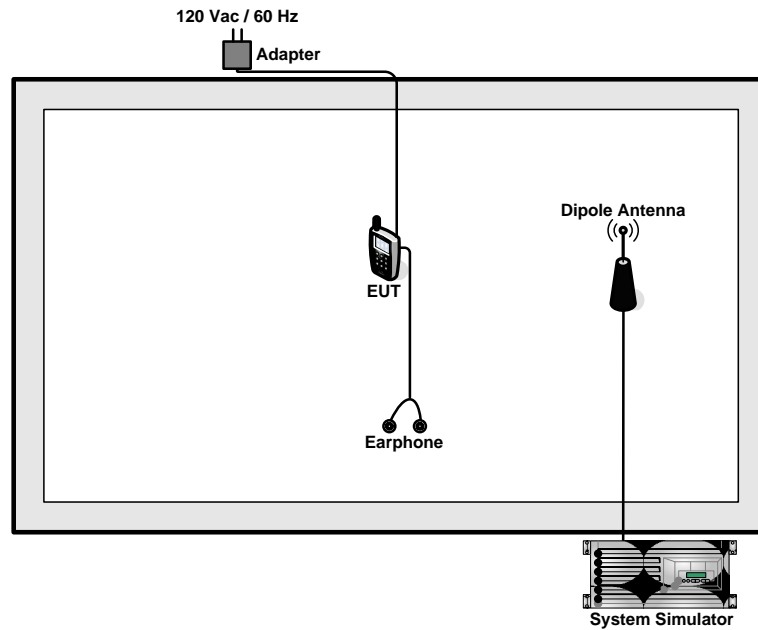

3 Test Result

3.1 Conducted Output Power Measurement

3.1.1 Description of the Conducted Output Power Measurement

A base station simulator was used to establish communication with the EUT. Its parameters were set to transmit the maximum power on the EUT. The measured power in the radio frequency on the transmitter output terminals shall be reported.

3.1.2 Measuring Instruments

See list of measuring instruments of this test report.

3.1.3 Test Procedures

1. The transmitter output port was connected to base station.
2. Set EUT at maximum power through base station.
3. Select lowest, middle, and highest channels for each band and different modulation.

3.1.4 Test Setup

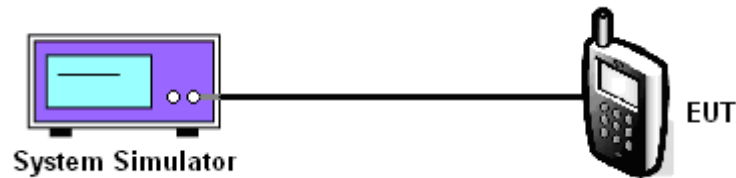



3.1.5 Test Result of Conducted Output Power

| Cellular Band | | | | |
|-----------------------------|-------------|-----------------|-----------------------|-------------------------|
| Modes | Channel | Frequency (MHz) | Conducted Power (dBm) | Conducted Power (Watts) |
| GSM850 (GSM) | 128 (Low) | 824.2 | 33.58 | 2.28 |
| | 189 (Mid) | 836.4 | 33.57 | 2.28 |
| | 251 (High) | 848.8 | 33.46 | 2.22 |
| GSM850 (EDGE 8) | 128 (Low) | 824.2 | 26.95 | 0.50 |
| | 189 (Mid) | 836.4 | 26.97 | 0.50 |
| | 251 (High) | 848.8 | 26.99 | 0.50 |
| WCDMA Band V (RMC 12.2Kbps) | 4132 (Low) | 826.4 | 22.77 | 0.19 |
| | 4182 (Mid) | 836.4 | 23.29 | 0.21 |
| | 4233 (High) | 846.6 | 22.79 | 0.19 |

| PCS Band | | | | |
|------------------------------|-------------|-----------------|-----------------------|-------------------------|
| Modes | Channel | Frequency (MHz) | Conducted Power (dBm) | Conducted Power (Watts) |
| GSM1900 (GSM) | 512 (Low) | 1850.2 | 30.56 | 1.14 |
| | 661 (Mid) | 1880.0 | 30.49 | 1.12 |
| | 810 (High) | 1909.8 | 30.45 | 1.11 |
| GSM1900 (EDGE 8) | 512 (Low) | 1850.2 | 24.97 | 0.31 |
| | 661 (Mid) | 1880.0 | 24.85 | 0.31 |
| | 810 (High) | 1909.8 | 24.94 | 0.31 |
| WCDMA Band II (RMC 12.2Kbps) | 9262 (Low) | 1852.4 | 23.06 | 0.20 |
| | 9400 (Mid) | 1880.0 | 23.39 | 0.22 |
| | 9538 (High) | 1907.6 | 22.92 | 0.20 |

3.2 Effective Radiated Power and Effective Isotropic Radiated Power Measurement

3.2.1 Description of the ERP/EIRP Measurement

ERP/EIRP is measured by substitution method according to ANSI / TIA / EIA-603-C-2004. The ERP of mobile transmitters must not exceed 7 Watts and the EIRP of mobile transmitters are limited to 2 Watts.

3.2.2 Measuring Instruments

See list of measuring instruments of this test report.

3.2.3 Test Procedures

1. The EUT was placed on an non-conductive rotating platform with 0.8 meter height in a semi-anechoic chamber. The radiated emission at the fundamental frequency was measured at 3 m with a test antenna and a spectrum analyzer with RBW= 3MHz,VBW= 3MHz, and peak detector settings.
2. During the measurement, the EUT was enforced in maximum power and linked with a base station. The highest emission was recorded from analyzer power level (LVL) from the 360 degrees rotation of the turntable and the test antenna raised and lowered over a range from 1 to 4 meters in both horizontally and vertically polarized orientations.
3. Effective Isotropic Radiated Power (EIRP) was measured by substitution method according to TIA/EIA-603-C. The EUT was replaced by dipole antenna (substitution antenna) at same location, and then a known power from S.G. was applied into the dipole antenna through a Tx cable, and then recorded the maximum Analyzer reading through raised and lowered the test antenna. The correction factor (in dB) = S.G. - Tx Cable loss + Substitution antenna gain - Analyzer reading. Then the EUT's EIRP was calculated with the correction factor, $EIRP = LVL + \text{Correction factor}$ and $ERP = EIRP - 2.15$.

3.2.4 Test Setup

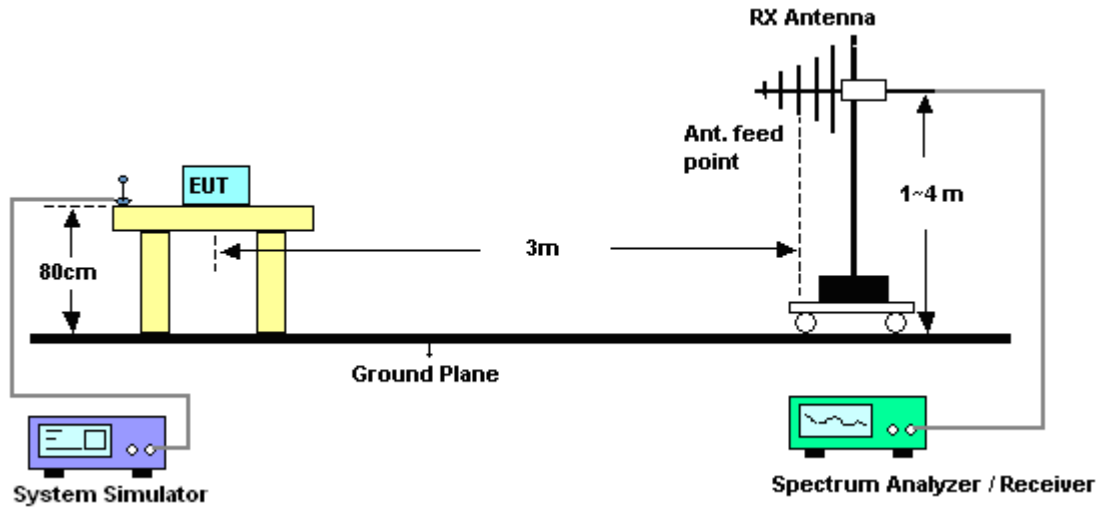

3.2.5 Test Result of ERP

| GSM850 (GSM) Radiated Power ERP | | | | |
|---------------------------------|-----------|------------------------|-----------|---------|
| Horizontal Polarization | | | | |
| Frequency (MHz) | LVL (dBm) | Correction Factor (dB) | ERP (dBm) | ERP (W) |
| 824.2 | -0.74 | 31.97 | 29.08 | 0.81 |
| 836.4 | -1.88 | 32.44 | 28.41 | 0.69 |
| 848.8 | -2.34 | 32.63 | 28.14 | 0.65 |
| Vertical Polarization | | | | |
| Frequency (MHz) | LVL (dBm) | Correction Factor (dB) | ERP (dBm) | ERP (W) |
| 824.2 | -9.68 | 35.39 | 23.56 | 0.23 |
| 836.4 | -10.83 | 35.2 | 22.22 | 0.17 |
| 848.8 | -12.18 | 35.69 | 21.36 | 0.14 |

* ERP = LVL (dBm) + Correction Factor (dB) – 2.15

| GSM850 (EDGE 8) Radiated Power ERP | | | | |
|------------------------------------|-----------|------------------------|-----------|---------|
| Horizontal Polarization | | | | |
| Frequency (MHz) | LVL (dBm) | Correction Factor (dB) | ERP (dBm) | ERP (W) |
| 824.2 | -3.72 | 31.97 | 26.10 | 0.41 |
| 836.4 | -4.86 | 32.44 | 25.43 | 0.35 |
| 848.8 | -5.64 | 32.63 | 24.84 | 0.30 |
| Vertical Polarization | | | | |
| Frequency (MHz) | LVL (dBm) | Correction Factor (dB) | ERP (dBm) | ERP (W) |
| 824.2 | -13.94 | 35.39 | 19.30 | 0.09 |
| 836.4 | -14.53 | 35.2 | 18.52 | 0.07 |
| 848.8 | -15.54 | 35.69 | 18.00 | 0.06 |

* ERP = LVL (dBm) + Correction Factor (dB) – 2.15



| WCDMA Band V (RMC 12.2Kbps) Radiated Power ERP | | | | |
|--|-----------|------------------------|-----------|---------|
| Horizontal Polarization | | | | |
| Frequency (MHz) | LVL (dBm) | Correction Factor (dB) | ERP (dBm) | ERP (W) |
| 826.40 | -10.23 | 31.97 | 19.59 | 0.09 |
| 836.40 | -10.71 | 32.44 | 19.58 | 0.09 |
| 846.60 | -10.44 | 32.63 | 20.04 | 0.10 |
| Vertical Polarization | | | | |
| Frequency (MHz) | LVL (dBm) | Correction Factor (dB) | ERP (dBm) | ERP (W) |
| 826.40 | -20.09 | 35.39 | 13.15 | 0.02 |
| 836.40 | -19.39 | 35.2 | 13.66 | 0.02 |
| 846.60 | -20.06 | 35.69 | 13.48 | 0.02 |

* ERP = LVL (dBm) + Correction Factor (dB) – 2.15



3.2.6 Test Result of EIRP

| GSM1900 (GSM) Radiated Power EIRP | | | | |
|-----------------------------------|-----------|------------------------|------------|----------|
| Horizontal Polarization | | | | |
| Frequency (MHz) | LVL (dBm) | Correction Factor (dB) | EIRP (dBm) | EIRP (W) |
| 1850.2 | -13.73 | 41.24 | 27.51 | 0.56 |
| 1880.0 | -14.32 | 41.46 | 27.14 | 0.52 |
| 1909.8 | -16.32 | 41.21 | 24.89 | 0.31 |
| Vertical Polarization | | | | |
| Frequency (MHz) | LVL (dBm) | Correction Factor (dB) | EIRP (dBm) | EIRP (W) |
| 1850.2 | -23.98 | 43.52 | 19.54 | 0.09 |
| 1880.0 | -23.51 | 43.10 | 19.59 | 0.09 |
| 1909.8 | -24.45 | 42.73 | 18.28 | 0.07 |

* EIRP = LVL (dBm) + Correction Factor (dB)

| GSM1900 (EDGE 8) Radiated Power EIRP | | | | |
|--------------------------------------|-----------|------------------------|------------|----------|
| Horizontal Polarization | | | | |
| Frequency (MHz) | LVL (dBm) | Correction Factor (dB) | EIRP (dBm) | EIRP (W) |
| 1850.2 | -15.94 | 41.24 | 25.30 | 0.34 |
| 1880.0 | -15.44 | 41.46 | 26.02 | 0.40 |
| 1909.8 | -17.77 | 41.21 | 23.44 | 0.22 |
| Vertical Polarization | | | | |
| Frequency (MHz) | LVL (dBm) | Correction Factor (dB) | EIRP (dBm) | EIRP (W) |
| 1850.2 | -24.45 | 43.52 | 19.07 | 0.08 |
| 1880.0 | -24.63 | 43.10 | 18.47 | 0.07 |
| 1909.8 | -25.78 | 42.73 | 16.95 | 0.05 |

* EIRP = LVL (dBm) + Correction Factor (dB)



| WCDMA Band II (RMC 12.2Kbps) Radiated Power EIRP | | | | |
|--|-----------|------------------------|------------|----------|
| Horizontal Polarization | | | | |
| Frequency (MHz) | LVL (dBm) | Correction Factor (dB) | EIRP (dBm) | EIRP (W) |
| 1852.40 | -20.43 | 41.24 | 20.81 | 0.12 |
| 1880.00 | -20.85 | 41.46 | 20.61 | 0.12 |
| 1907.60 | -22.16 | 41.21 | 19.05 | 0.08 |
| Vertical Polarization | | | | |
| Frequency (MHz) | LVL (dBm) | Correction Factor (dB) | EIRP (dBm) | EIRP (W) |
| 1852.40 | -28.11 | 43.52 | 15.41 | 0.03 |
| 1880.00 | -29.30 | 43.10 | 13.80 | 0.02 |
| 1907.60 | -29.85 | 42.73 | 12.88 | 0.02 |

* EIRP = LVL (dBm) + Correction Factor (dB)

3.3 Occupied Bandwidth Measurement

3.3.1 Description of Occupied Bandwidth Measurement

The emission bandwidth is defined as the width of the signal between two points, located at the 2 sides of the carrier frequency, outside of which all emissions are attenuated at least 26 dB below the transmitter power.

3.3.2 Measuring Instruments

See list of measuring instruments of this test report.

3.3.3 Test Procedures

1. The EUT was connected to Spectrum Analyzer and Base Station via power divider.
2. The 99% and 26 dB occupied bandwidth (BW) of the middle channel for the highest RF powers were measured.

3.3.4 Test Setup

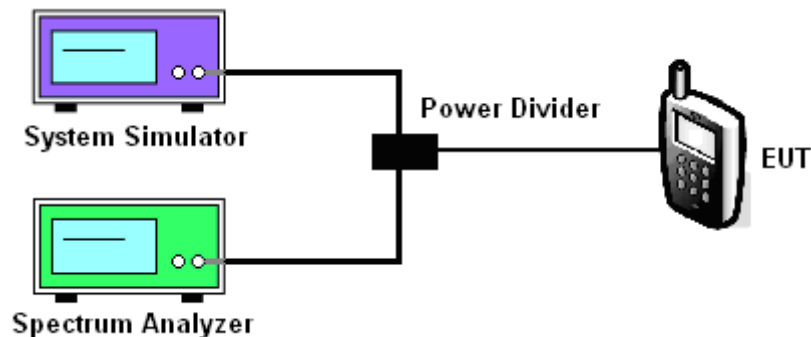



3.3.5 Test Result (Plots) of Occupied Bandwidth

| | | | |
|-------------|----------|---------------|------|
| Band : | GSM 850 | Power Stage : | High |
| Test Mode : | GSM Link | | |

99% Occupied Bandwidth Plot on Channel 189

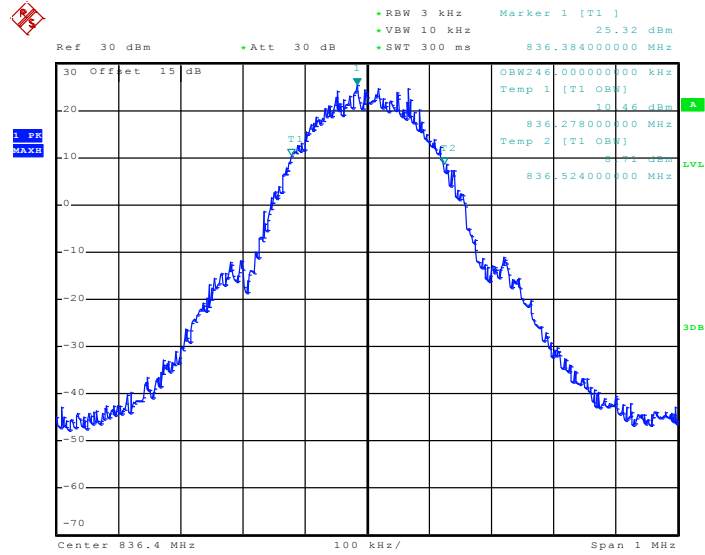

Date: 7.SEP.2010 14:07:44

26dB Bandwidth Plot on Channel 189

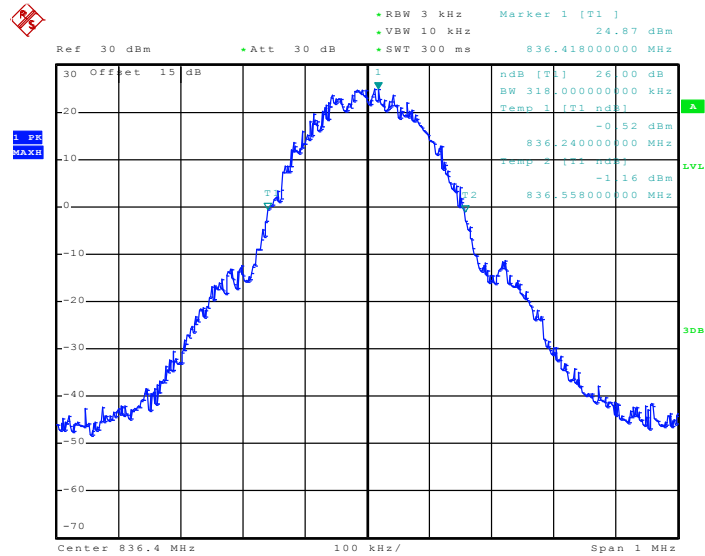

Date: 7.SEP.2010 14:06:26



| | | | |
|--------------------|-------------|----------------------|------|
| Band : | GSM 850 | Power Stage : | High |
| Test Mode : | EDGE 8 Link | | |

99% Occupied Bandwidth Plot on Channel 189

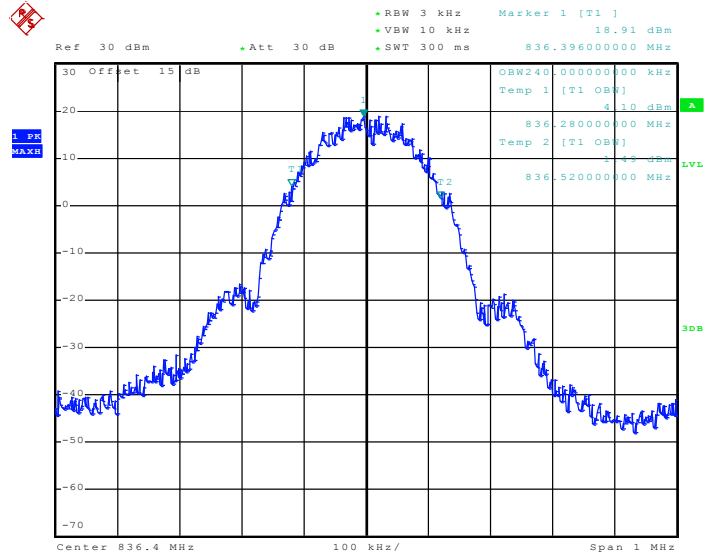

Date: 7.SEP.2010 14:44:27

26dB Bandwidth Plot on Channel 189

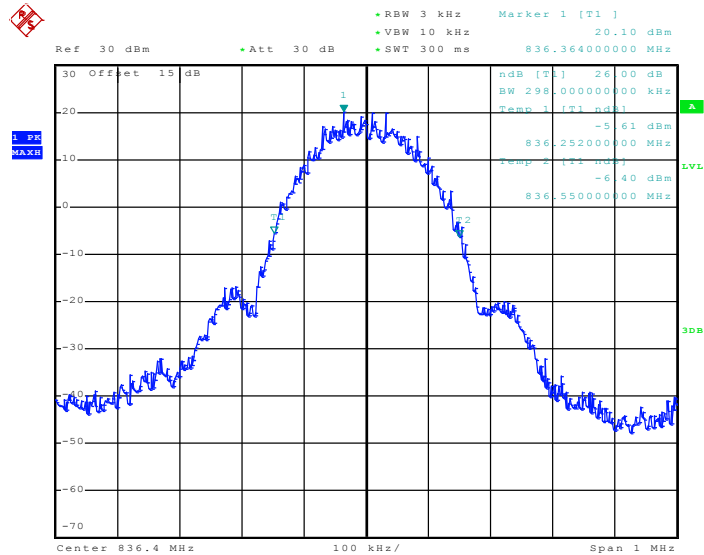

Date: 7.SEP.2010 14:43:09



| | | | |
|--------------------|----------|----------------------|------|
| Band : | GSM 1900 | Power Stage : | High |
| Test Mode : | GSM Link | | |

99% Occupied Bandwidth Plot on Channel 661

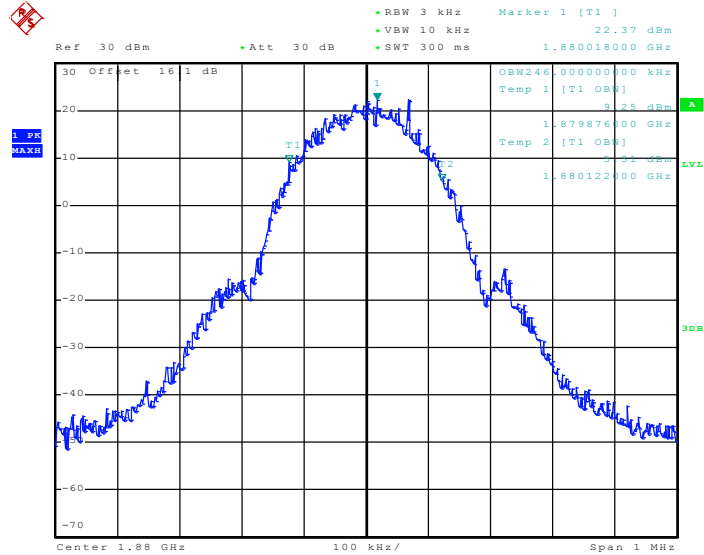

Date: 7.SEP.2010 15:28:16

26dB Bandwidth Plot on Channel 661

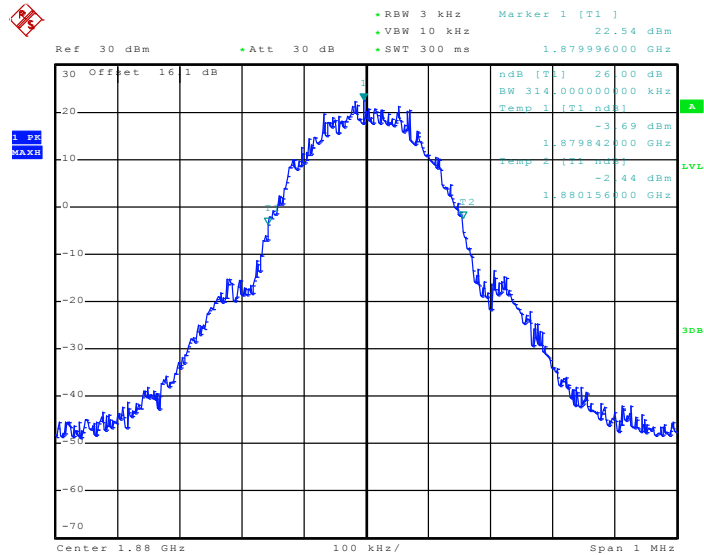

Date: 7.SEP.2010 15:26:58



| | | | |
|--------------------|-------------|----------------------|------|
| Band : | GSM 1900 | Power Stage : | High |
| Test Mode : | EDGE 8 Link | | |

99% Occupied Bandwidth Plot on Channel 661

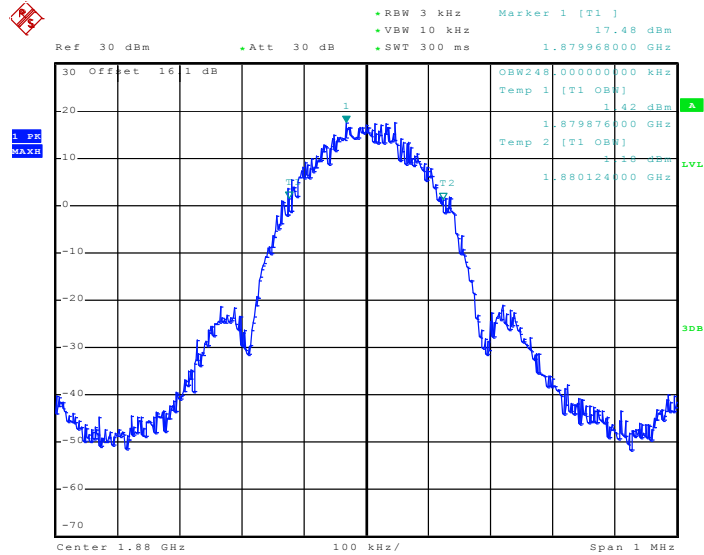

Date: 7.SEP.2010 16:00:22

26dB Bandwidth Plot on Channel 661

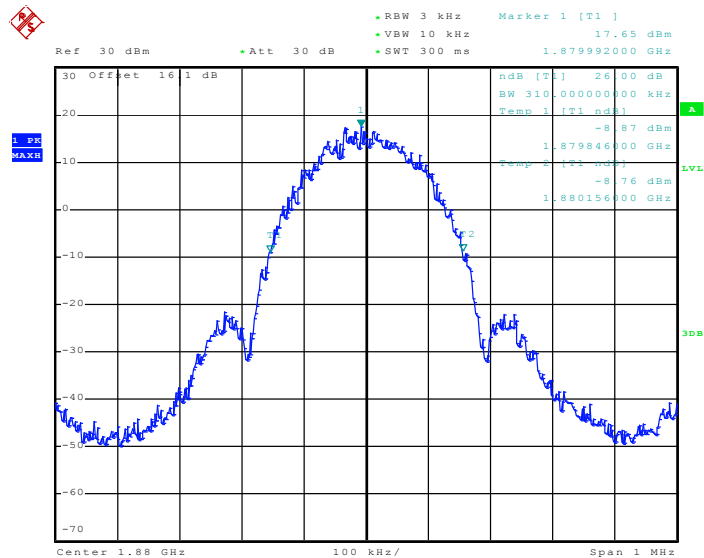

Date: 7.SEP.2010 15:59:04



| | | | |
|--------------------|-------------------|----------------------|------|
| Band : | WCDMA Band V | Power Stage : | High |
| Test Mode : | RMC 12.2Kbps Link | | |

99% Occupied Bandwidth Plot on Channel 4182

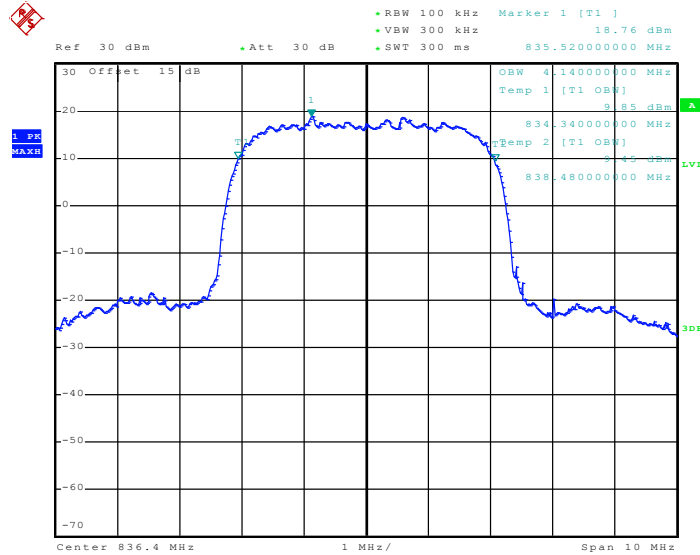

Date: 7.SEP.2010 17:54:34

26dB Bandwidth Plot on Channel 4182

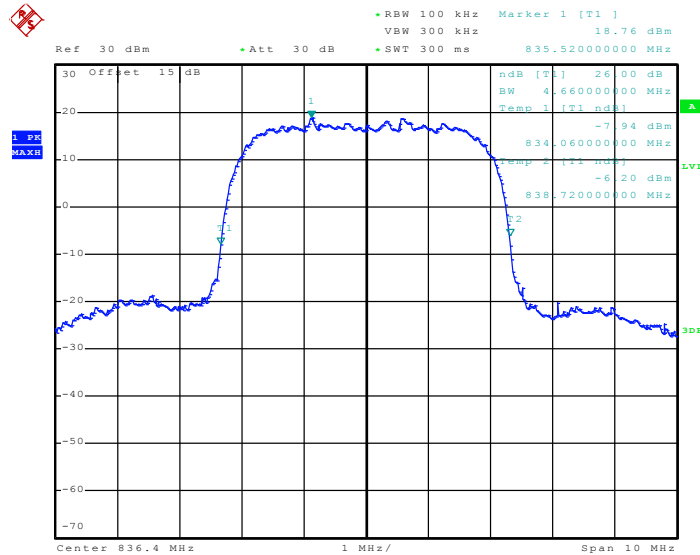

Date: 7.SEP.2010 17:36:59



| | | | |
|--------------------|-------------------|----------------------|------|
| Band : | WCDMA Band II | Power Stage : | High |
| Test Mode : | RMC 12.2Kbps Link | | |

99% Occupied Bandwidth Plot on Channel 9400

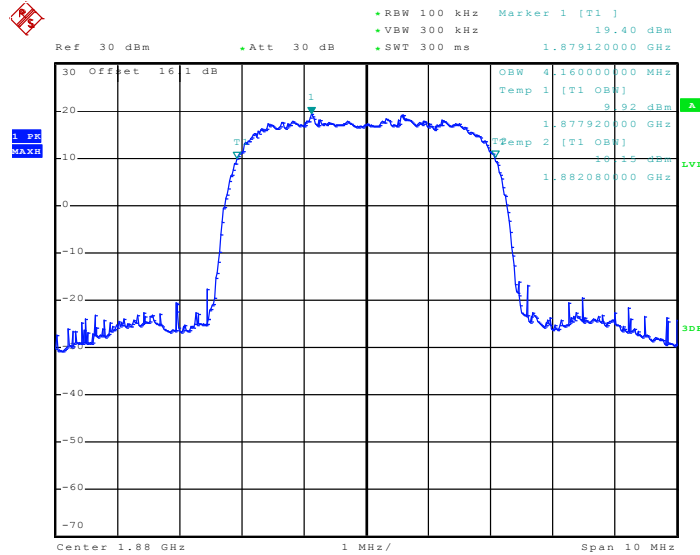

Date: 7.SEP.2010 17:07:08

26dB Bandwidth Plot on Channel 9400

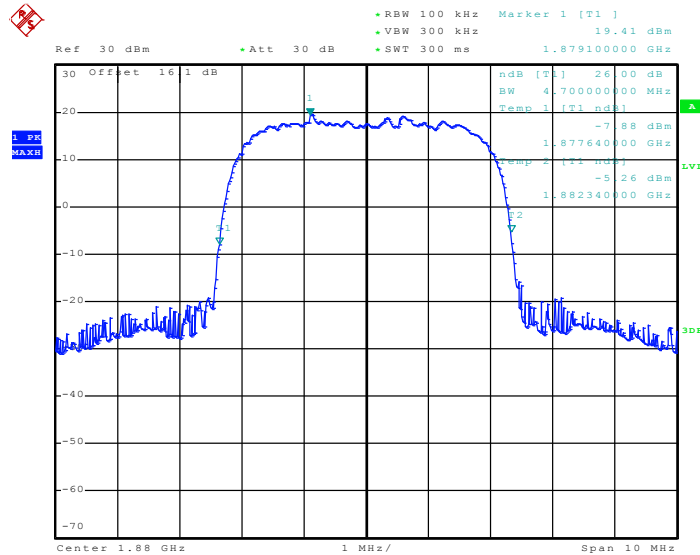

Date: 7.SEP.2010 16:50:21

3.4 Band Edge Measurement

3.4.1 Description of Band Edge Measurement

The power of any emission outside of the authorized operating frequency ranges must be lower than the transmitter power (P) by a factor of at least $43 + 10 \log (P)$ dB.

3.4.2 Measuring Instruments

See list of measuring instruments of this test report.

3.4.3 Test Procedures

1. The EUT was connected to Spectrum Analyzer and Base Station via power divider.
2. The band edges of low and high channels for the highest RF powers were measured. Setting RBW as roughly BW/100.

3.4.4 Test Setup

<Conducted Band Edge >

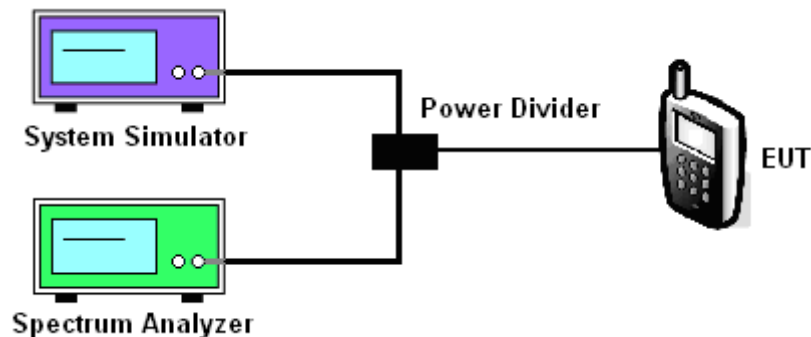



3.4.5 Test Result (Plots) of Conducted Band Edge

| | | | |
|-------------|----------|---------------|------|
| Band : | GSM850 | Power Stage : | High |
| Test Mode : | GSM Link | | |

Lower Band Edge Plot on Channel 128

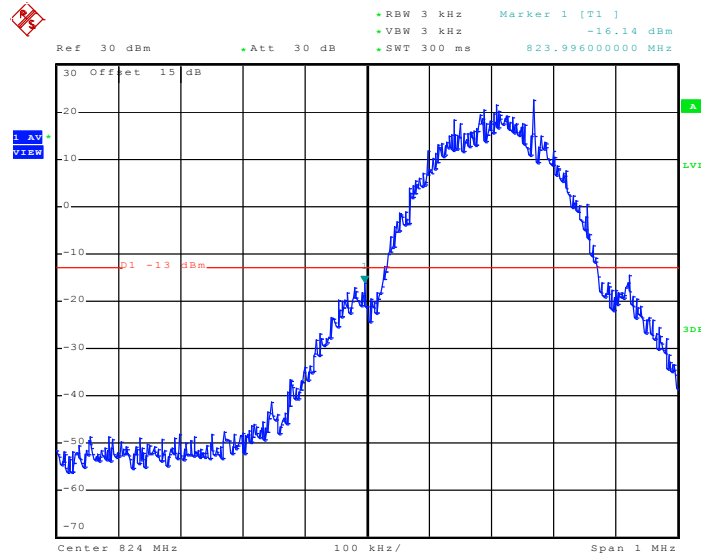

Date: 7.SEP.2010 14:09:36

Higher Band Edge Plot on Channel 251

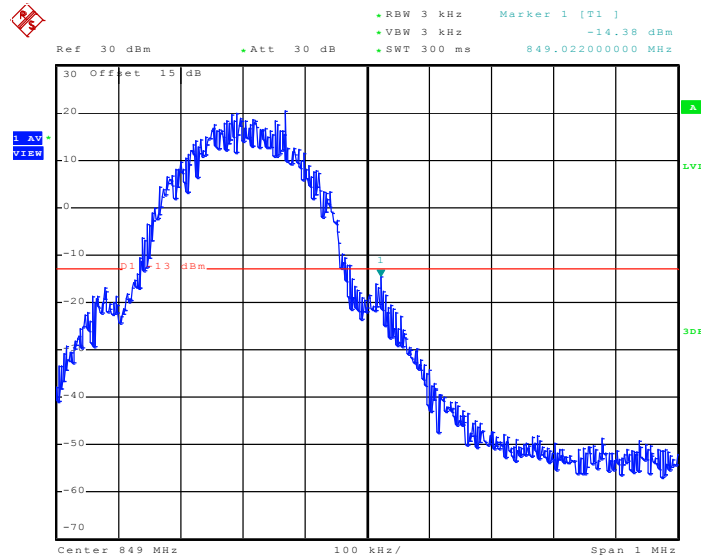

Date: 7.SEP.2010 14:10:02



| | | | |
|-------------|-------------|---------------|------|
| Band : | GSM850 | Power Stage : | High |
| Test Mode : | EDGE 8 Link | | |

Lower Band Edge Plot on Channel 128

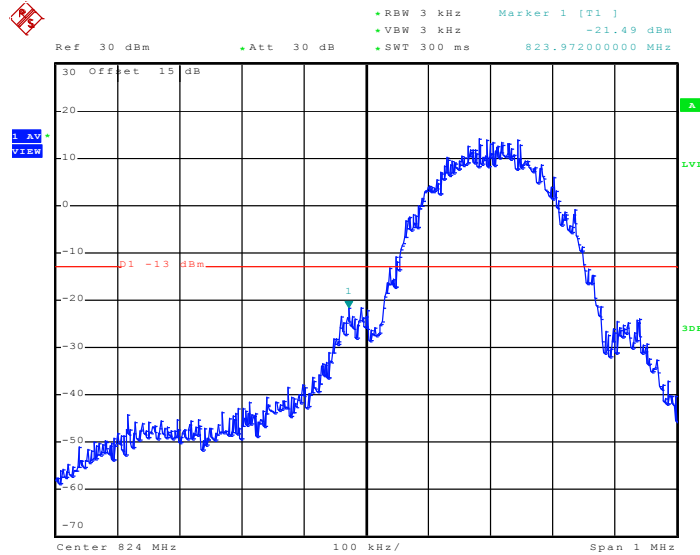

Date: 7.SEP.2010 14:46:19

Higher Band Edge Plot on Channel 251

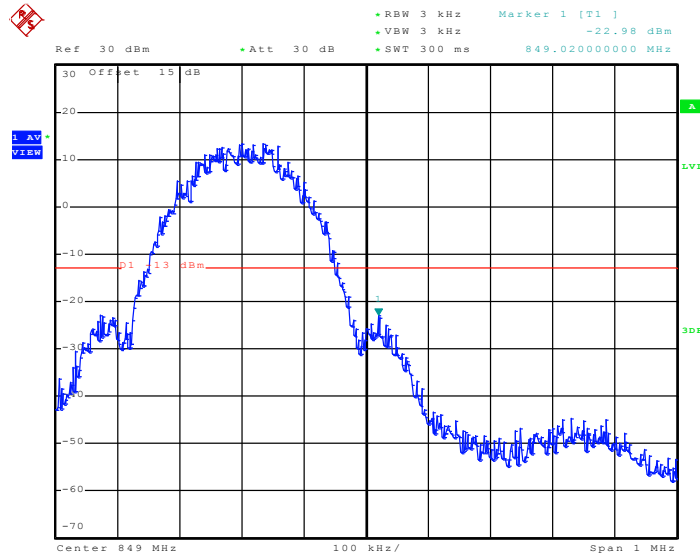

Date: 7.SEP.2010 14:46:45



| | | | |
|-------------|----------|---------------|------|
| Band : | GSM1900 | Power Stage : | High |
| Test Mode : | GSM Link | | |

Lower Band Edge Plot on Channel 512

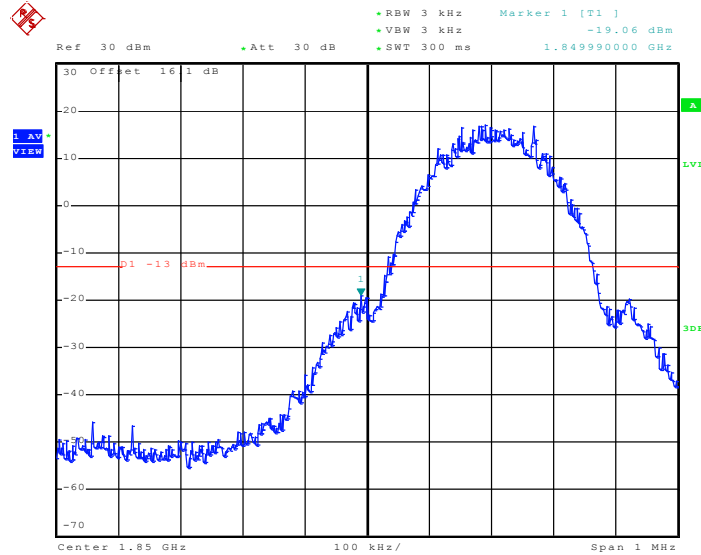

Date: 7.SEP.2010 15:35:44

Higher Band Edge Plot on Channel 810

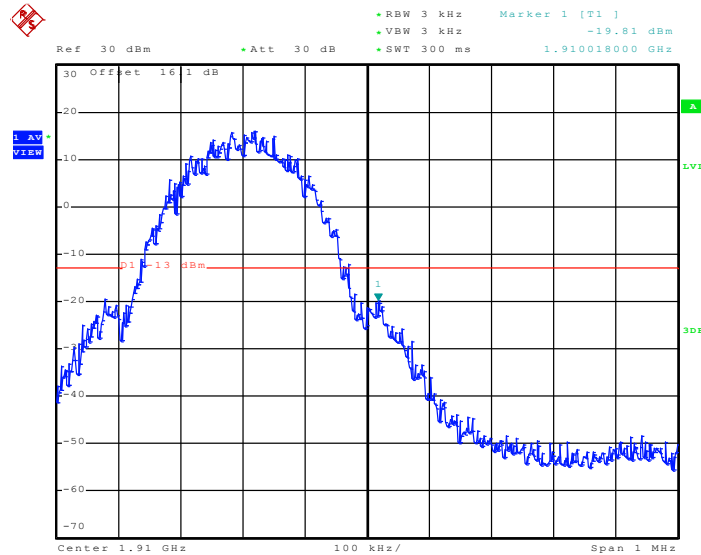

Date: 7.SEP.2010 15:30:33



| | | | |
|-------------|-------------|---------------|------|
| Band : | GSM1900 | Power Stage : | High |
| Test Mode : | EDGE 8 Link | | |

Lower Band Edge Plot on Channel 512

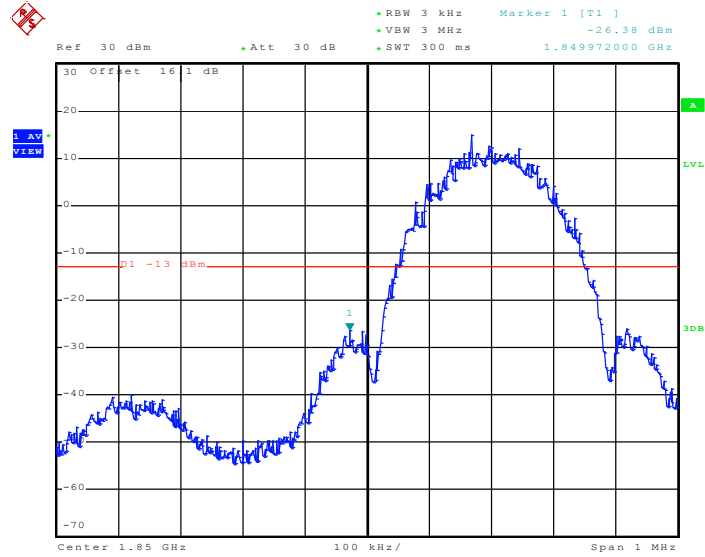

Date: 7.SEP.2010 16:07:02

Higher Band Edge Plot on Channel 810

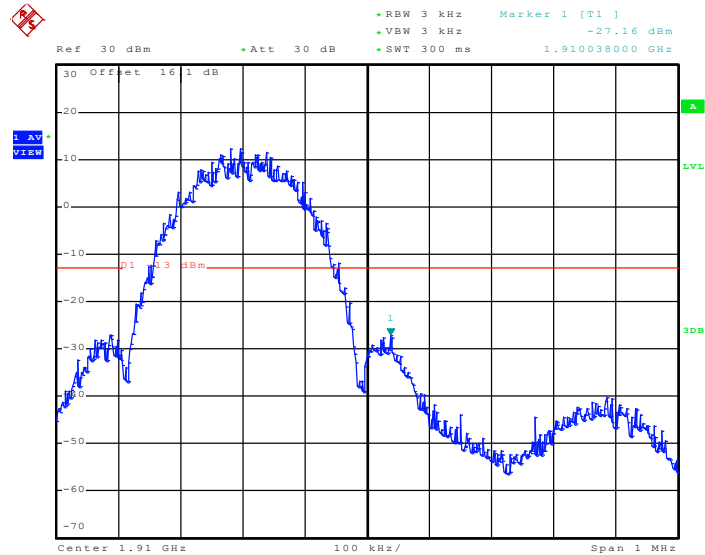

Date: 7.SEP.2010 16:02:39



| | | | |
|--------------------|-------------------|----------------------|------|
| Band : | WCDMA Band V | Power Stage : | High |
| Test Mode : | RMC 12.2Kbps Link | | |

Lower Band Edge Plot on Channel 4132

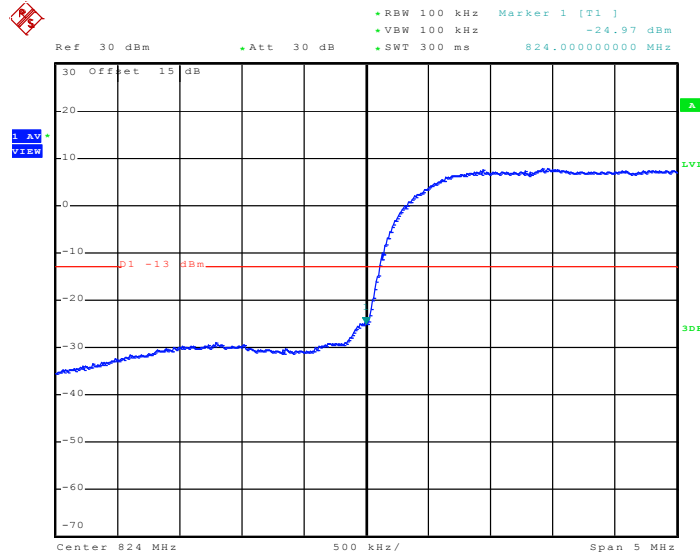

Date: 7.SEP.2010 17:40:40

Higher Band Edge Plot on Channel 4233

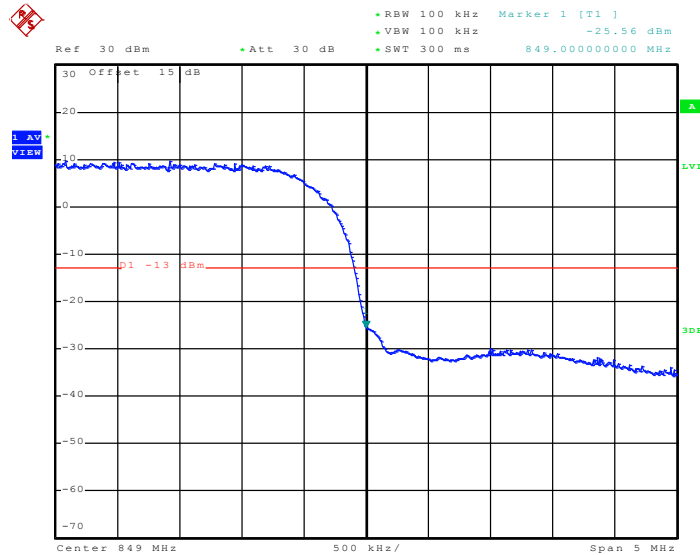

Date: 7.SEP.2010 17:46:58



| | | | |
|-------------|-------------------|---------------|------|
| Band : | WCDMA Band II | Power Stage : | High |
| Test Mode : | RMC 12.2Kbps Link | | |

Lower Band Edge Plot on Channel 9262

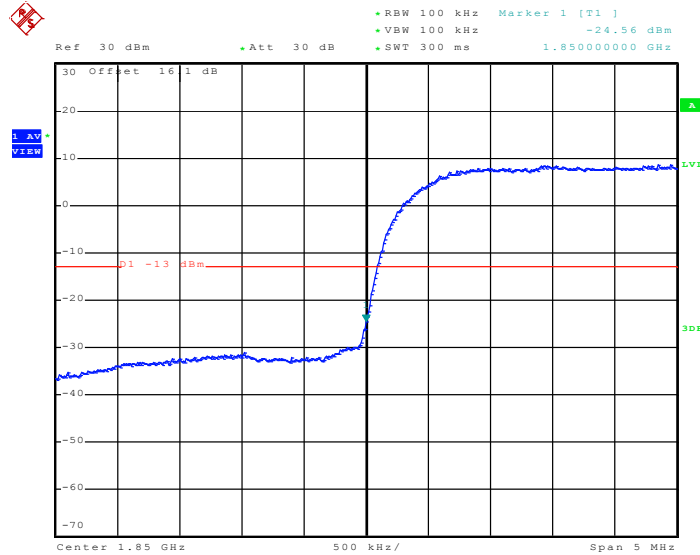

Date: 7.SEP.2010 16:56:20

Higher Band Edge Plot on Channel 9538

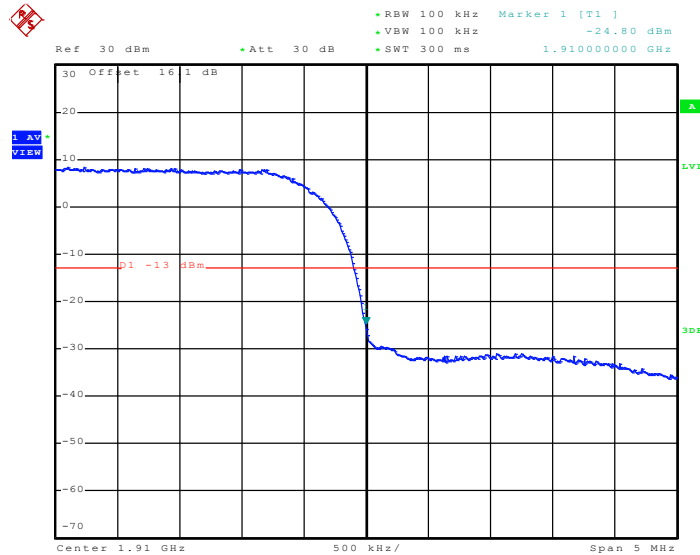

Date: 7.SEP.2010 17:02:57

3.5 Conducted Emission Measurement

3.5.1 Description of Conducted Emission Measurement

The power of any emission outside of the authorized operating frequency ranges must be lower than the transmitter power (P) by a factor of at least $43 + 10 \log (P)$ dB.

It is measured by means of a calibrated spectrum analyzer and scanned from 30 MHz up to a frequency including its 10th harmonic.

3.5.2 Measuring Instruments

See list of measuring instruments of this test report.

3.5.3 Test Procedures

1. The EUT was connected to spectrum analyzer and base station via power divider.
2. The middle channel for the highest RF power within the transmitting frequency was measured.
3. The conducted spurious emission for the whole frequency range was taken.

3.5.4 Test Setup

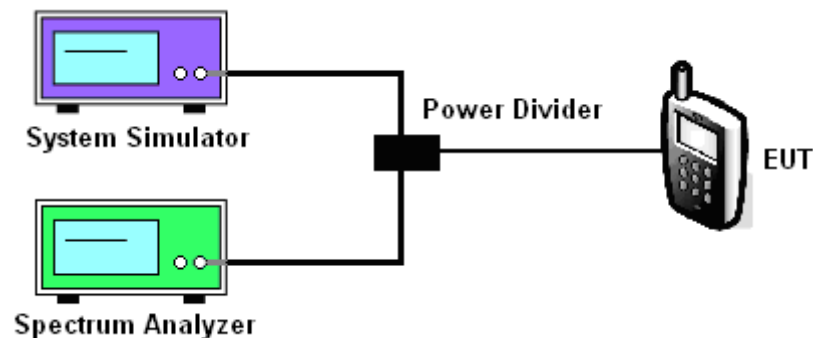



3.5.5 Test Result (Plots) of Conducted Emission

| | | | |
|-------------|----------|-----------|-------|
| Band : | GSM850 | Channel : | CH189 |
| Test Mode : | GSM Link | | |

Conducted Emission Plot between 30MHz ~ 1GHz

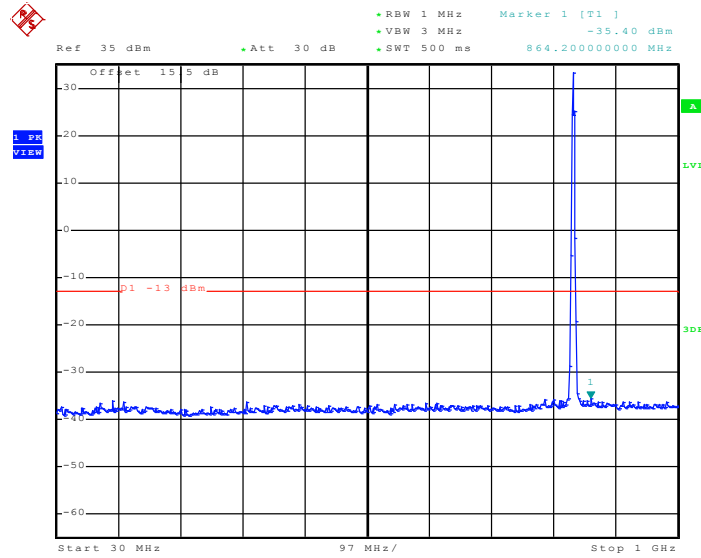

Date: 7.SEP.2010 14:33:07

Conducted Emission Plot between 1GHz ~ 3GHz

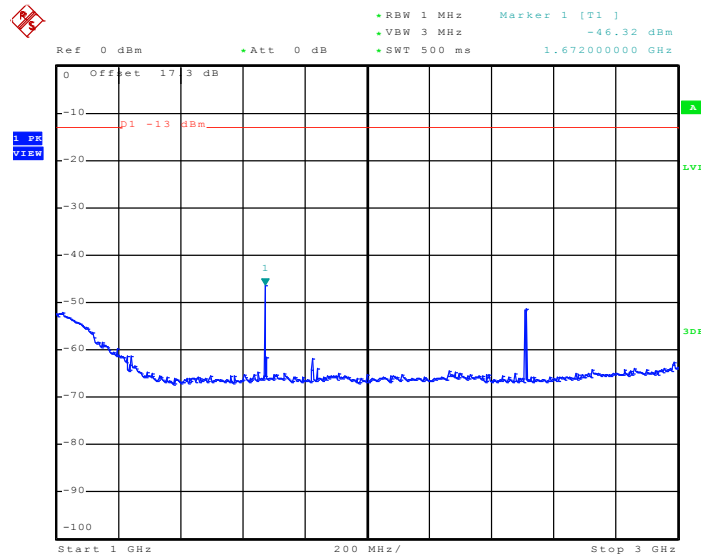

Date: 7.SEP.2010 14:37:31



Conducted Emission Plot between 3GHz ~ 7GHz

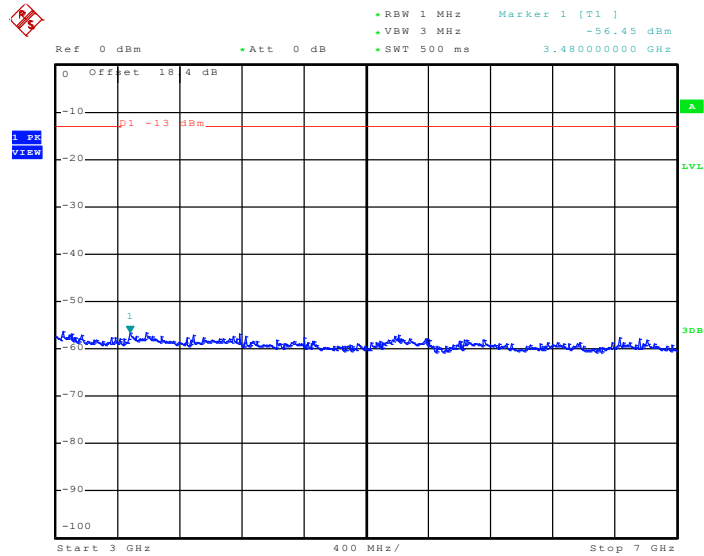

Date: 7.SEP.2010 14:34:01

Conducted Emission Plot between 7GHz ~ 9GHz

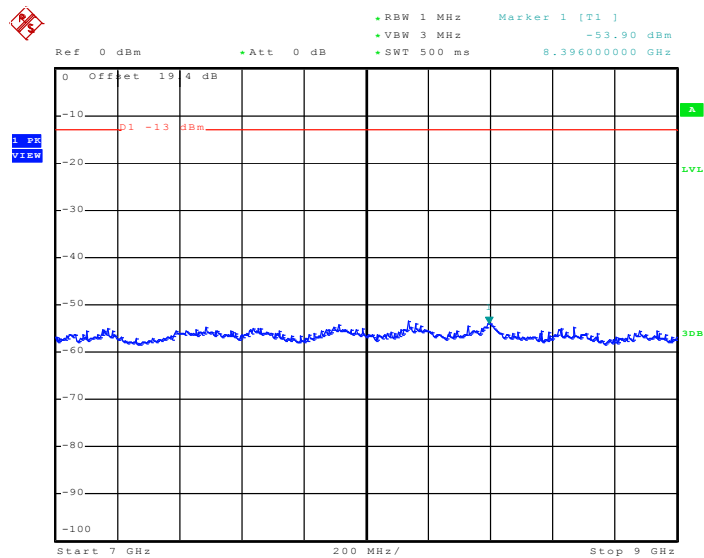

Date: 7.SEP.2010 14:34:14



| | | | |
|-------------|-------------|-----------|-------|
| Band : | GSM850 | Channel : | CH189 |
| Test Mode : | EDGE 8 Link | | |

Conducted Emission Plot between 30MHz ~ 1GHz

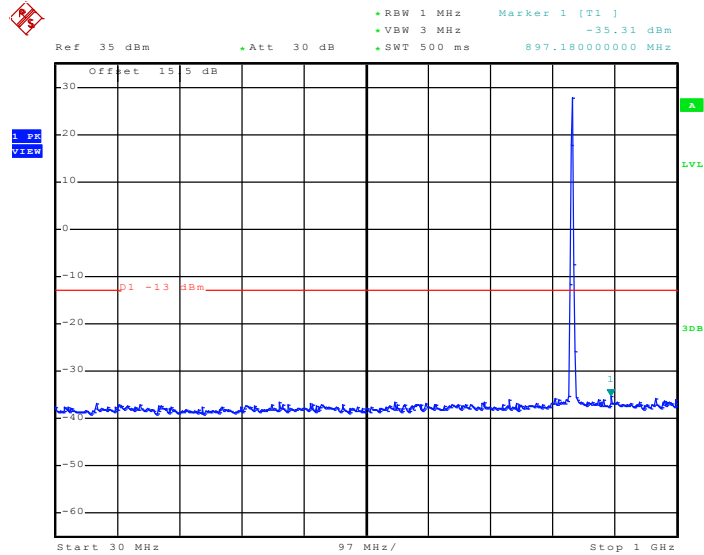

Date: 7.SEP.2010 15:00:58

Conducted Emission Plot between 1GHz ~ 3GHz

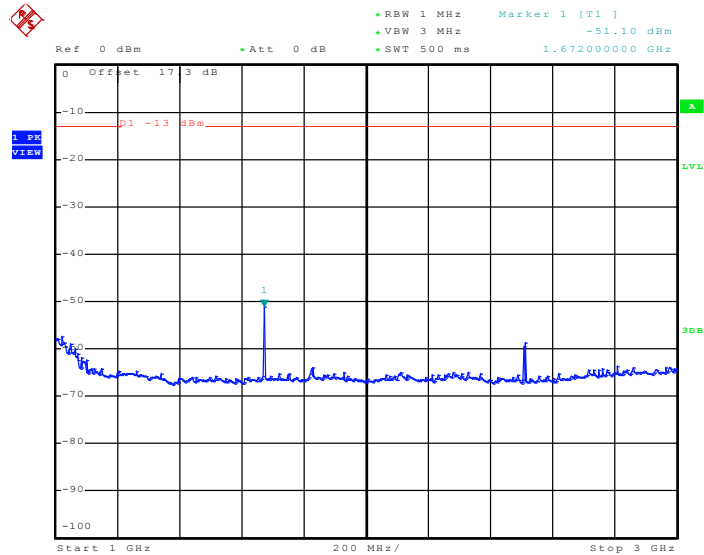

Date: 7.SEP.2010 15:03:45



Conducted Emission Plot between 3GHz ~ 7GHz

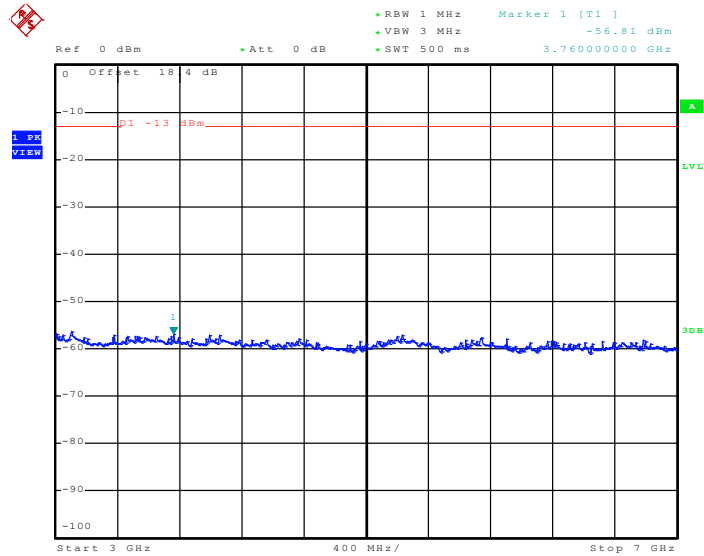

Date: 7.SEP.2010 15:01:49

Conducted Emission Plot between 7GHz ~ 9GHz

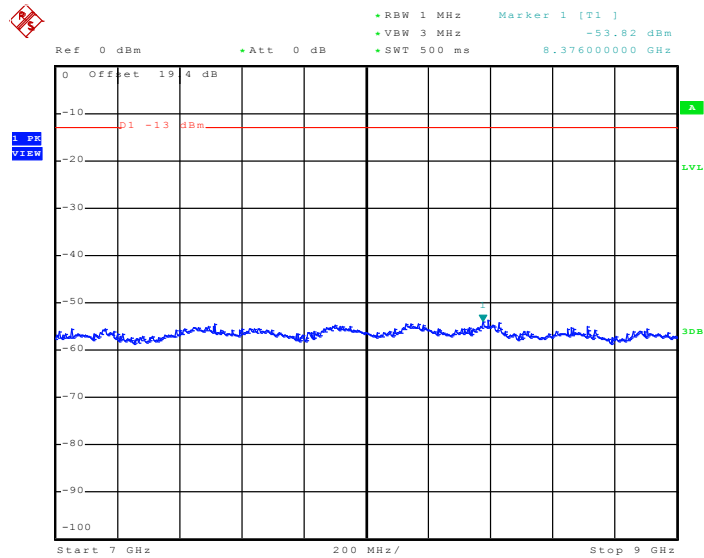

Date: 7.SEP.2010 15:02:02



| | | | |
|-------------|----------|-----------|-------|
| Band : | GSM1900 | Channel : | CH661 |
| Test Mode : | GSM Link | | |

Conducted Emission Plot between 30MHz ~ 1GHz

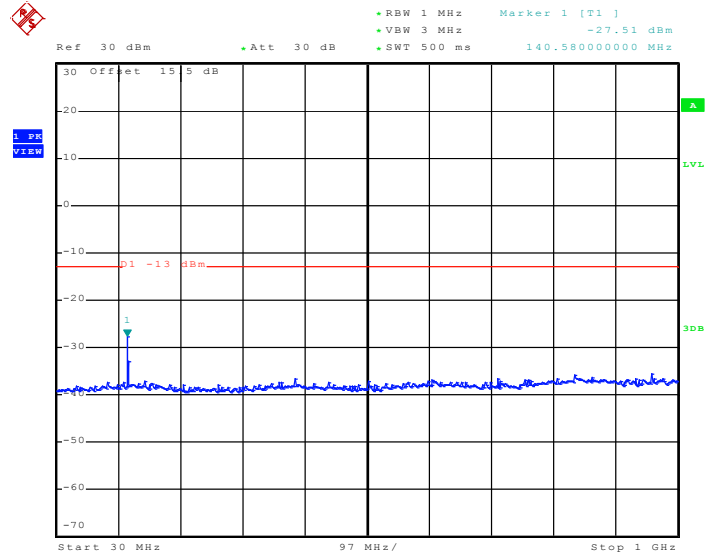

Date: 7.SEP.2010 15:43:57

Conducted Emission Plot between 1GHz ~ 3GHz

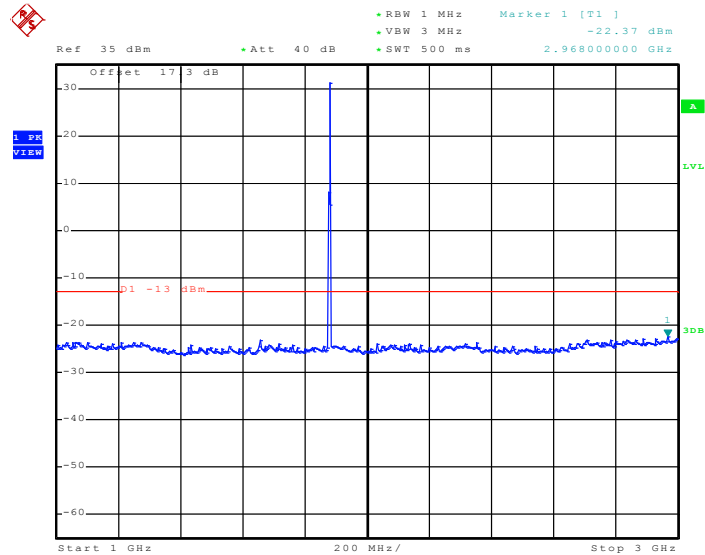

Date: 7.SEP.2010 15:46:02



Conducted Emission Plot between 3GHz ~ 7GHz

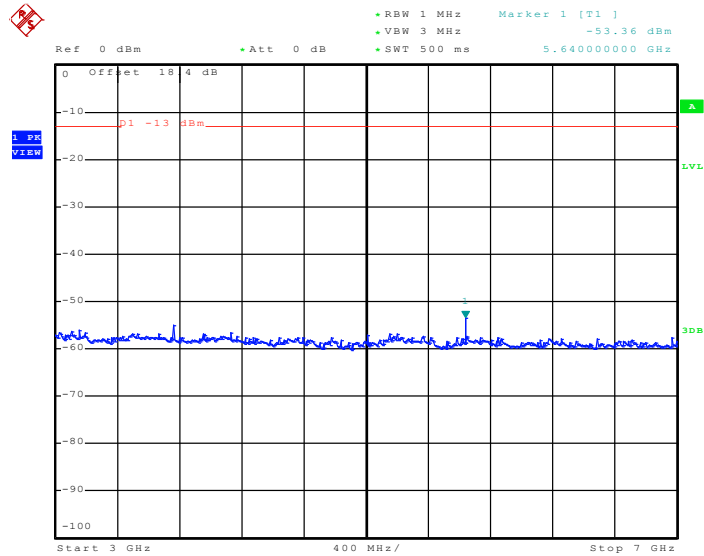

Date: 7.SEP.2010 15:49:44

Conducted Emission Plot between 7GHz ~ 13.6GHz

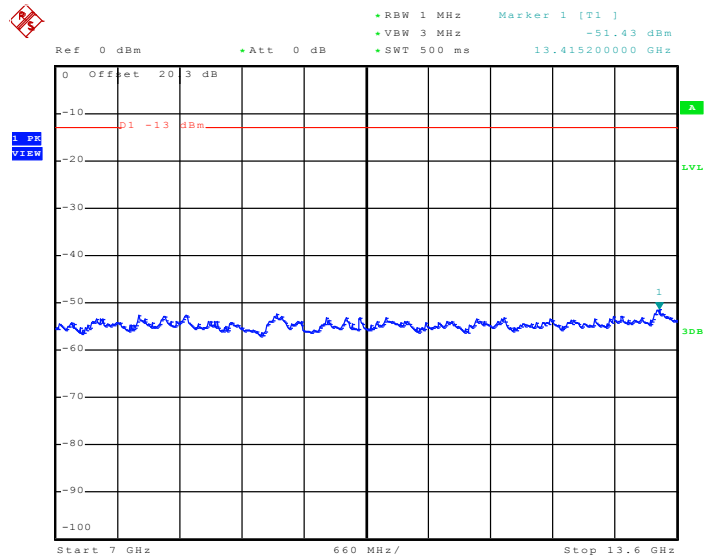

Date: 7.SEP.2010 15:53:21



Conducted Emission Plot between 13.6GHz ~ 19.1GHz

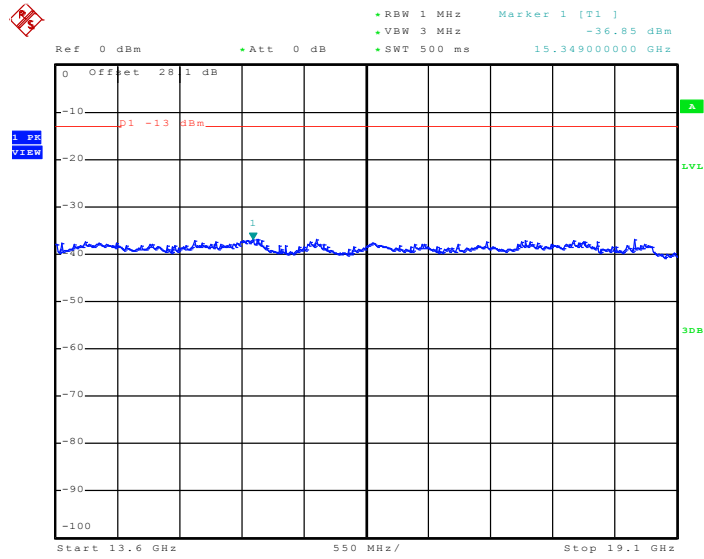

Date: 7.SEP.2010 15:54:48



| | | | |
|-------------|-------------|-----------|-------|
| Band : | GSM1900 | Channel : | CH661 |
| Test Mode : | EDGE 8 Link | | |

Conducted Emission Plot between 30MHz ~ 1GHz

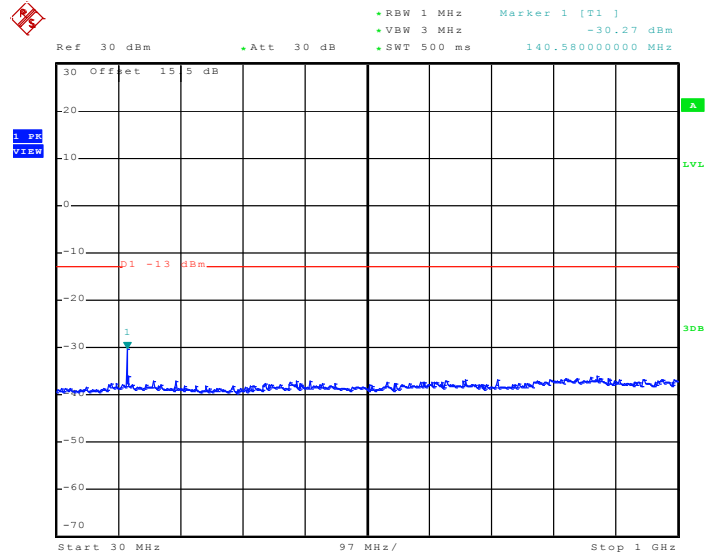

Date: 7.SEP.2010 16:13:38

Conducted Emission Plot between 1GHz ~ 3GHz

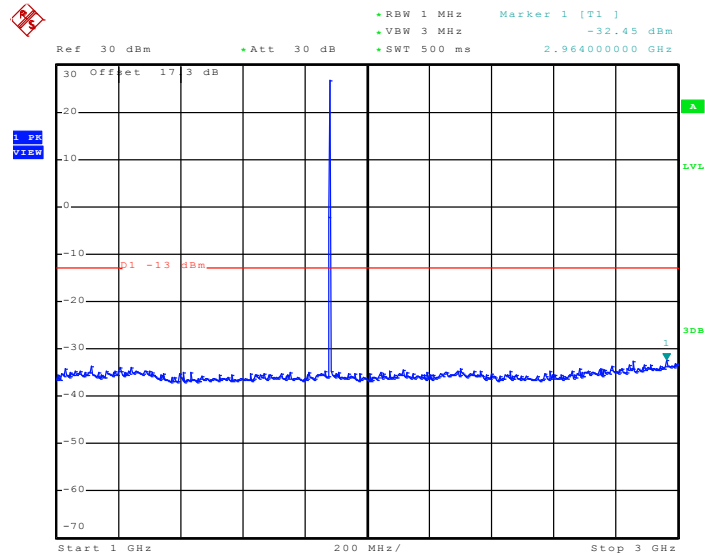

Date: 7.SEP.2010 16:16:19



Conducted Emission Plot between 3GHz ~ 7GHz

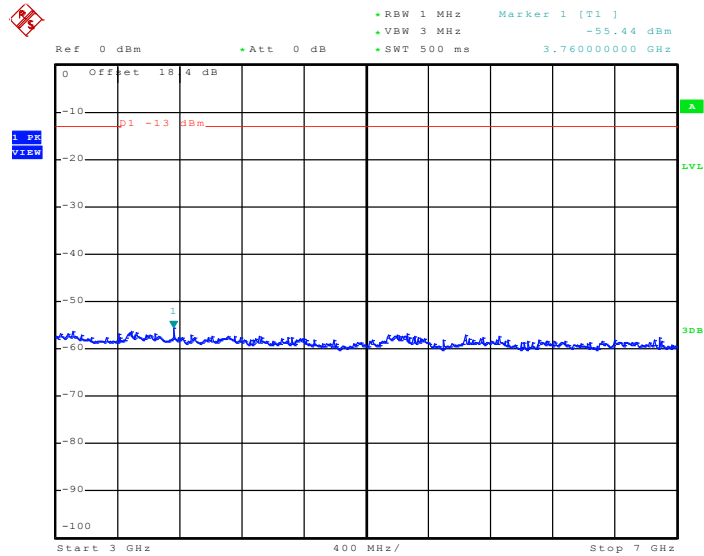

Date: 7.SEP.2010 16:18:14

Conducted Emission Plot between 7GHz ~ 13.6GHz

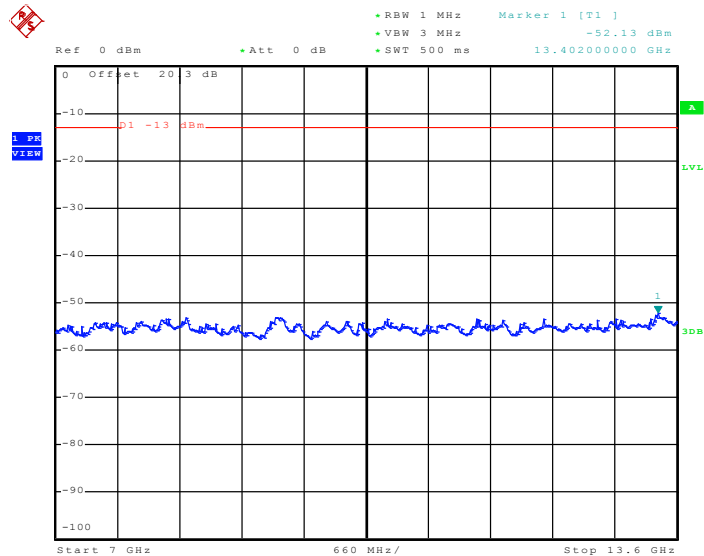

Date: 7.SEP.2010 16:19:24



Conducted Emission Plot between 13.6GHz ~ 19.1GHz

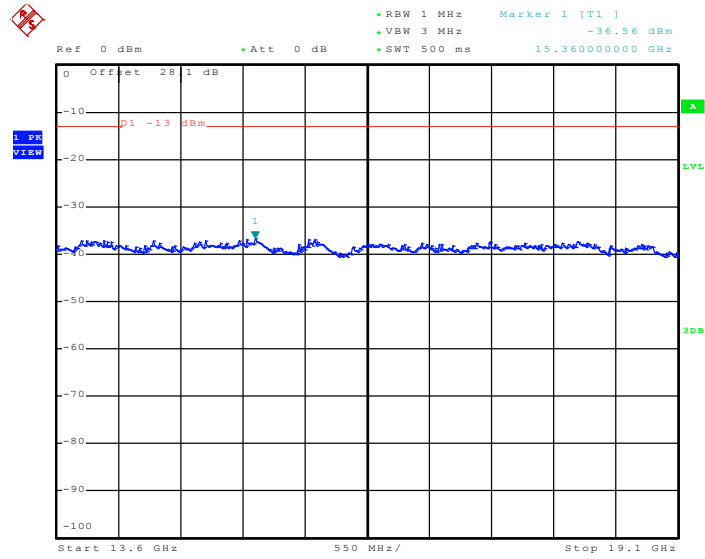

Date: 7.SEP.2010 16:38:56



| | | | |
|-------------|-------------------|-----------|--------|
| Band : | WCDMA Band V | Channel : | CH4182 |
| Test Mode : | RMC 12.2Kbps Link | | |

Conducted Emission Plot between 30MHz ~ 1GHz

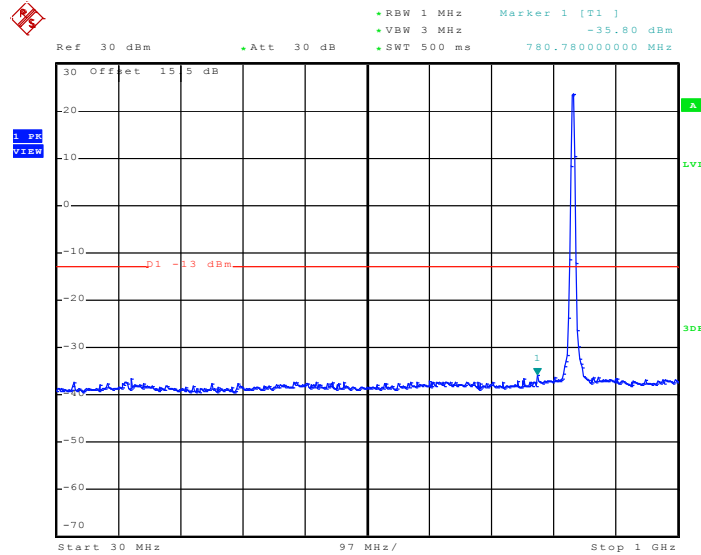

Date: 7.SEP.2010 18:03:44

Conducted Emission Plot between 1GHz ~ 3GHz

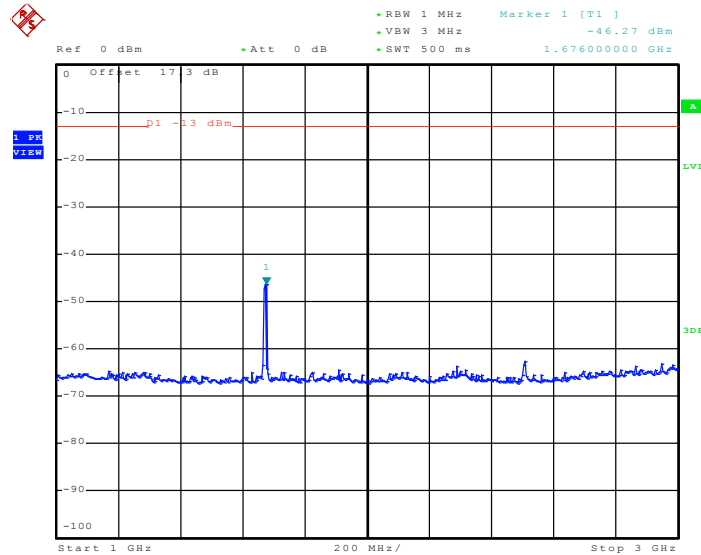

Date: 7.SEP.2010 18:06:56



Conducted Emission Plot between 3GHz ~ 7GHz

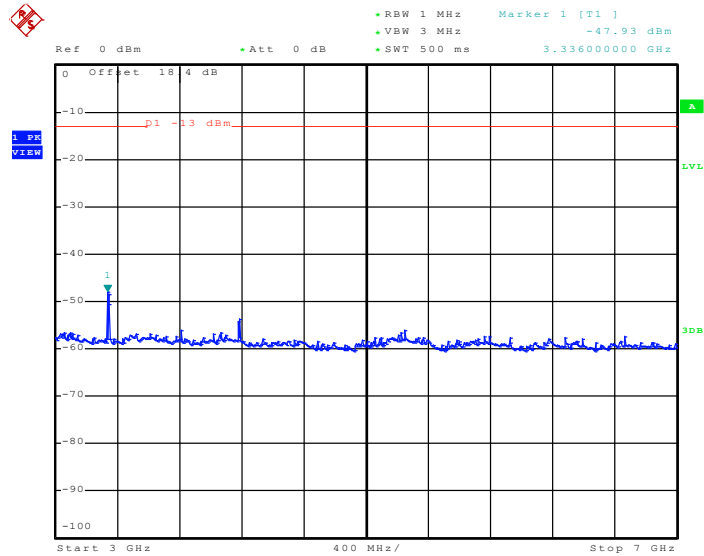

Date: 7.SEP.2010 18:08:45

Conducted Emission Plot between 7GHz ~ 9GHz

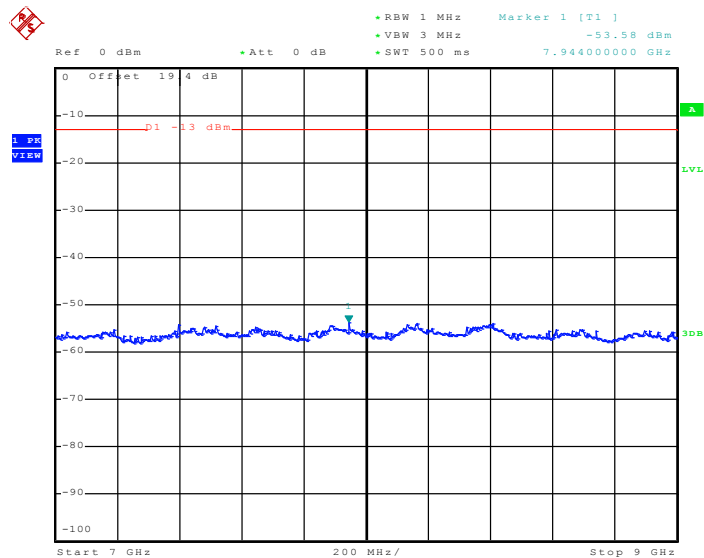

Date: 7.SEP.2010 18:10:02



| | | | |
|-------------|-------------------|-----------|--------|
| Band : | WCDMA Band II | Channel : | CH9400 |
| Test Mode : | RMC 12.2Kbps Link | | |

Conducted Emission Plot between 30MHz ~ 1GHz

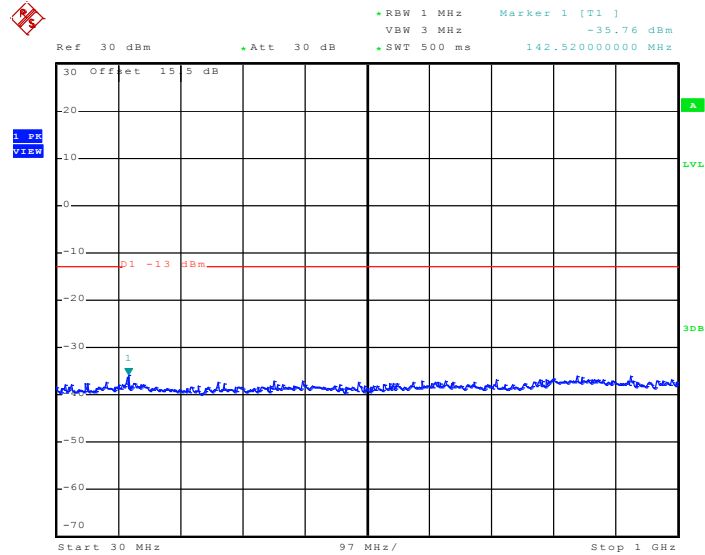

Date: 7.SEP.2010 17:20:16

Conducted Emission Plot between 1GHz ~ 3GHz

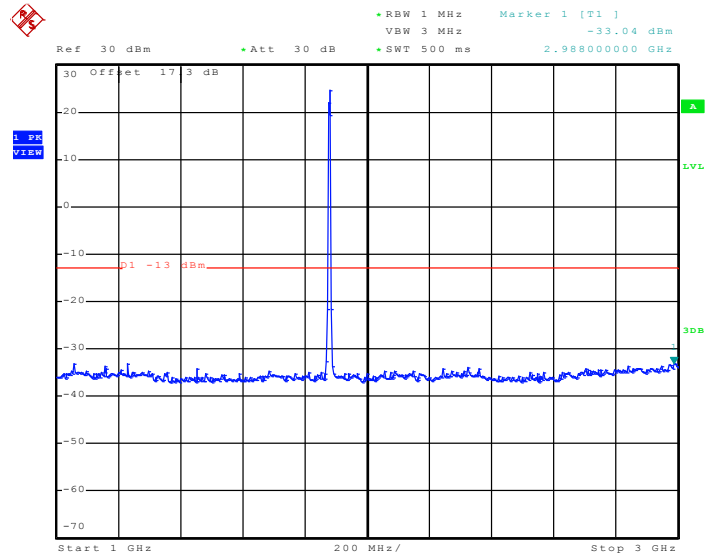

Date: 7.SEP.2010 17:22:44



Conducted Emission Plot between 3GHz ~ 7GHz

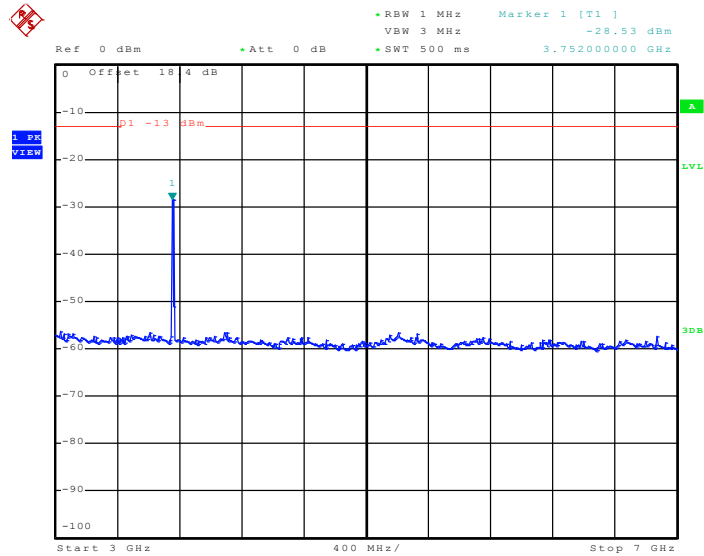

Date: 7.SEP.2010 17:24:31

Conducted Emission Plot between 7GHz ~ 13.6GHz

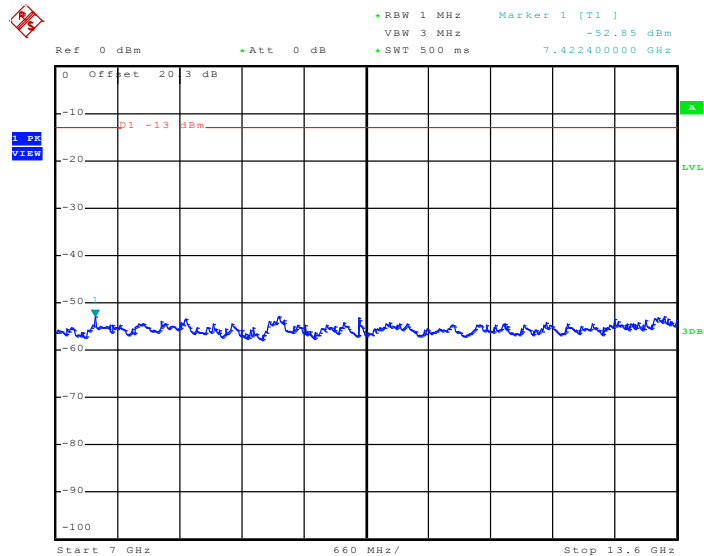

Date: 7.SEP.2010 17:25:27



Conducted Emission Plot between 13.6GHz ~ 19.1GHz

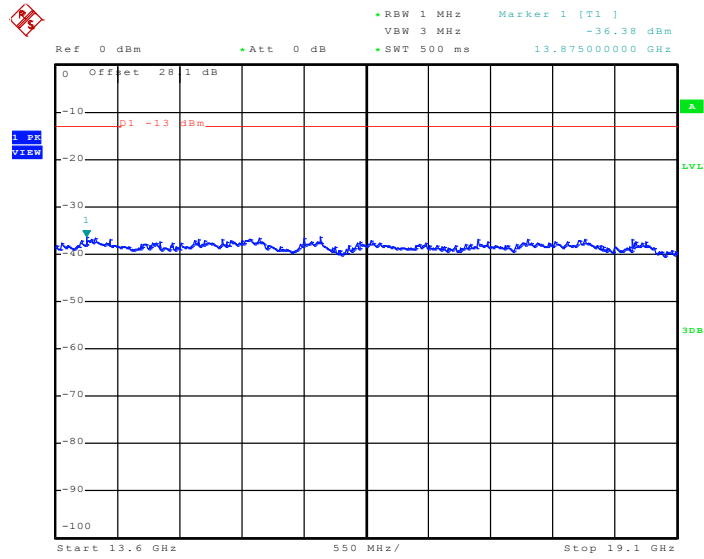

Date: 7.SEP.2010 17:27:18



3.6 Field Strength of Spurious Radiation Measurement

3.6.1 Description of Field Strength of Spurious Radiated Measurement

The radiated spurious emission was measured by substitution method according to ANSI / TIA / EIA-603-C-2004. The power of any emission outside of the authorized operating frequency ranges must be attenuated below the transmitter power (P) by a factor of at least $43 + 10 \log (P)$ dB. The spectrum is scanned from 30 MHz up to a frequency including its 10th harmonic.

3.6.2 Measuring Instruments

See list of measuring instruments of this test report.

3.6.3 Test Procedures

4. The EUT was placed on a rotatable wooden table with 0.8 meter about ground.
5. The EUT was set 3 meters from the receiving antenna, which was mounted on the antenna tower.
6. The table was rotated 360 degrees to determine the position of the highest spurious emission.
7. The height of the receiving antenna is varied between one meter and four meters to search the maximum spurious emission for both horizontal and vertical polarizations.
8. Make the measurement with the spectrum analyzer's RBW = 1MHz, VBW = 3MHz, Sweep = 500ms, Taking the record of maximum spurious emission.
9. A horn antenna was substituted in place of the EUT and was driven by a signal generator.
10. Tune the output power of signal generator to the same emission level with EUT maximum spurious emission.
11. Taking the record of output power at antenna port.
12. Repeat step 7 to step 8 for another polarization.
13. $EIRP \text{ (dBm)} = S.G. \text{ Power} - Tx \text{ Cable Loss} + Tx \text{ Antenna Gain}$
14. $ERP \text{ (dBm)} = EIRP - 2.15$

3.6.4 Test Setup

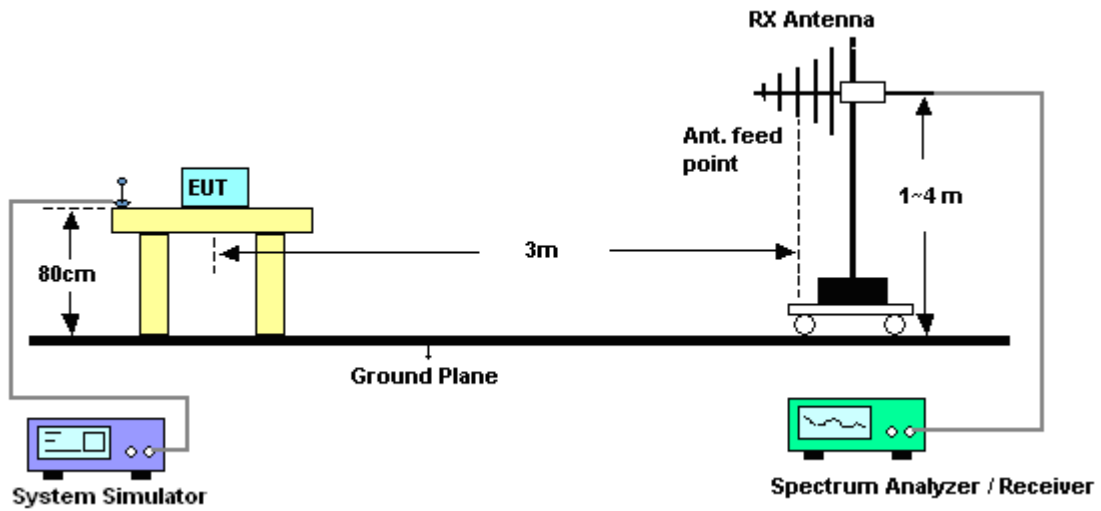



3.6.5 Test Result of Field Strength of Spurious Radiated

| | | | |
|-----------------|--|---------------------|------------|
| Band : | GSM850 | Temperature : | 25~26°C |
| Test Mode : | GSM Link | Relative Humidity : | 48~51% |
| Test Engineer : | Cona Huang | Polarization : | Horizontal |
| Remark : | Spurious emissions within 30-1000MHz were found more than 20dB below limit line. | | |

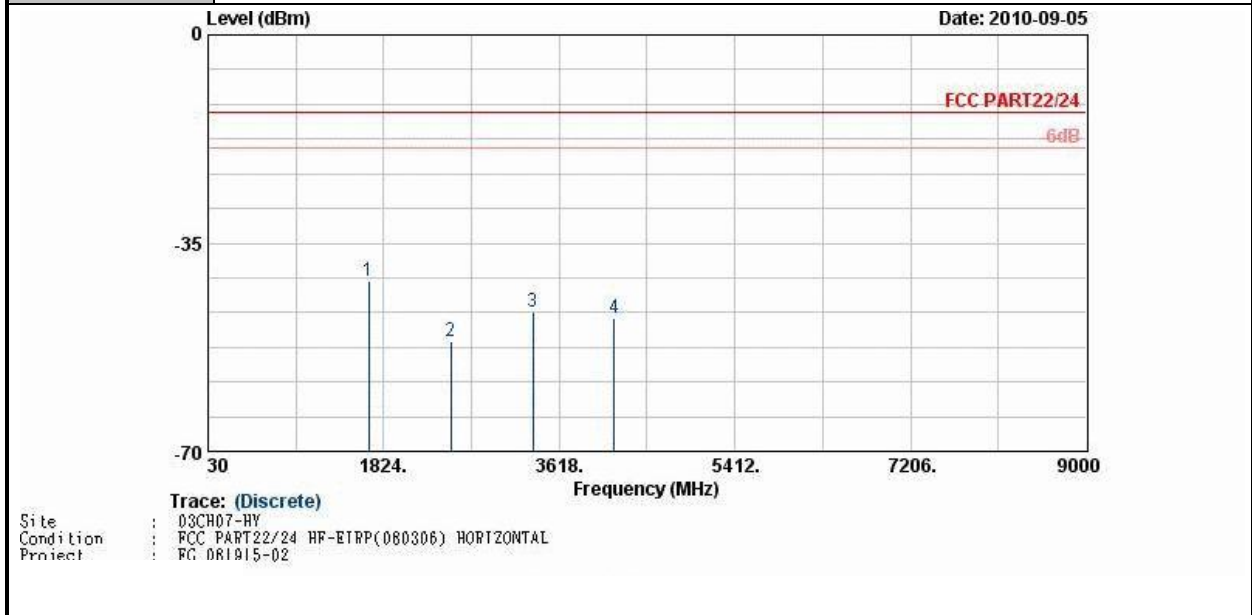

| Frequency (MHz) | ERP (dBm) | Limit (dBm) | Over Limit (dB) | SPA Reading (dBm) | S.G. Power (dBm) | TX Cable loss (dB) | TX Antenna Gain (dBi) | Polarization (H/V) | Result |
|-------------------|-------------|---------------|-------------------|---------------------|--------------------|----------------------|-------------------------|----------------------|--------|
| 1669 | -41.38 | -13 | -28.38 | -50.93 | -43.1 | 1.62 | 5.49 | H | Pass |
| 2509 | -51.43 | -13 | -38.43 | -65.43 | -53.4 | 2.1 | 6.22 | H | Pass |
| 3345 | -46.62 | -13 | -33.62 | -62.6 | -49.51 | 3.03 | 8.07 | H | Pass |
| 4182 | -47.55 | -13 | -34.55 | -65.33 | -52.09 | 2.52 | 9.21 | H | Pass |



| | | | |
|------------------------|--|----------------------------|----------|
| Band : | GSM850 | Temperature : | 25~26°C |
| Test Mode : | GSM Link | Relative Humidity : | 48~51% |
| Test Engineer : | Cona Huang | Polarization : | Vertical |
| Remark : | Spurious emissions within 30-1000MHz were found more than 20dB below limit line. | | |

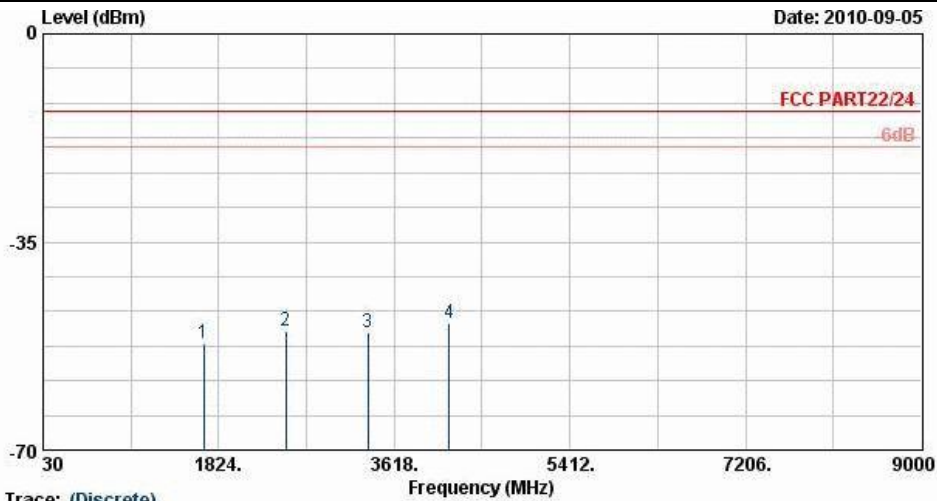

Trace: (Discrete)
 Site : 03CH07-RV
 Condition : FCC PART22/24 HF-ETRP(080306) VERTICAL
 Project : FG 081915-02

| Frequency (MHz) | ERP (dBm) | Limit (dBm) | Over Limit (dB) | SPA Reading (dBm) | S.G. Power (dBm) | TX Cable loss (dB) | TX Antenna Gain (dBi) | Polarization (H/V) | Result |
|-------------------|-------------|---------------|-------------------|---------------------|--------------------|----------------------|-------------------------|----------------------|--------|
| 1669 | -52.04 | -13 | -39.04 | -61.59 | -53.76 | 1.62 | 5.49 | V | Pass |
| 2509 | -49.84 | -13 | -36.84 | -63.84 | -51.81 | 2.1 | 6.22 | V | Pass |
| 3345 | -50.29 | -13 | -37.29 | -66.27 | -53.18 | 3.03 | 8.07 | V | Pass |
| 4182 | -48.75 | -13 | -35.75 | -66.53 | -53.29 | 2.52 | 9.21 | V | Pass |



| | | | |
|------------------------|--|----------------------------|------------|
| Band : | GSM850 | Temperature : | 25~26°C |
| Test Mode : | EDGE 8 Link | Relative Humidity : | 48~51% |
| Test Engineer : | Cona Huang | Polarization : | Horizontal |
| Remark : | Spurious emissions within 30-1000MHz were found more than 20dB below limit line. | | |

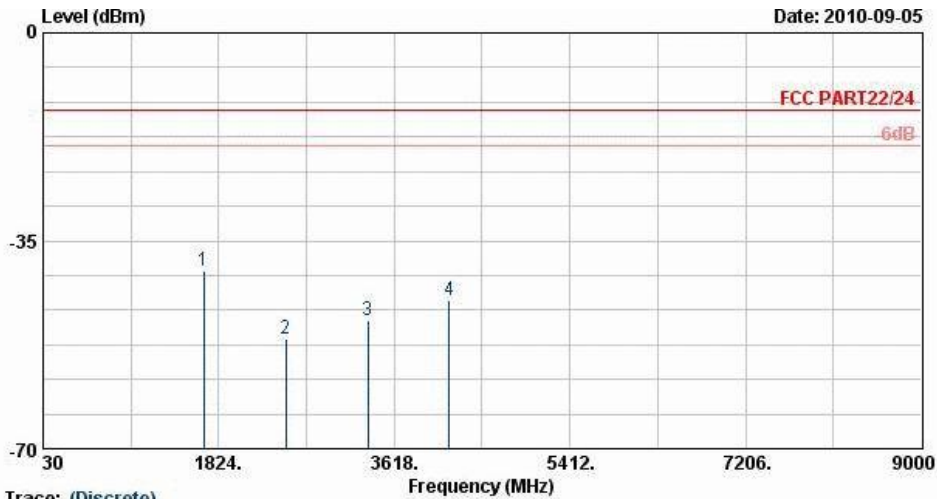

Trace: (Discrete)
 Site : 03CH07-RV
 Condition : FCC PART22/24 HF-ETRP(080306) HORIZONTAL
 Project : RC 081915-02

| Frequency (MHz) | ERP (dBm) | Limit (dBm) | Over Limit (dB) | SPA Reading (dBm) | S.G. Power (dBm) | TX Cable loss (dB) | TX Antenna Gain (dBi) | Polarization (H/V) | Result |
|-------------------|-------------|---------------|-------------------|---------------------|--------------------|----------------------|-------------------------|----------------------|--------|
| 1669 | -40.20 | -13 | -27.20 | -49.75 | -41.92 | 1.62 | 5.49 | H | Pass |
| 2509 | -51.45 | -13 | -38.45 | -65.45 | -53.42 | 2.1 | 6.22 | H | Pass |
| 3345 | -48.37 | -13 | -35.37 | -64.35 | -51.26 | 3.03 | 8.07 | H | Pass |
| 4182 | -45.09 | -13 | -32.09 | -62.87 | -49.63 | 2.52 | 9.21 | H | Pass |



| | | | |
|------------------------|--|----------------------------|----------|
| Band : | GSM850 | Temperature : | 25~26°C |
| Test Mode : | EDGE 8 Link | Relative Humidity : | 48~51% |
| Test Engineer : | Cona Huang | Polarization : | Vertical |
| Remark : | Spurious emissions within 30-1000MHz were found more than 20dB below limit line. | | |

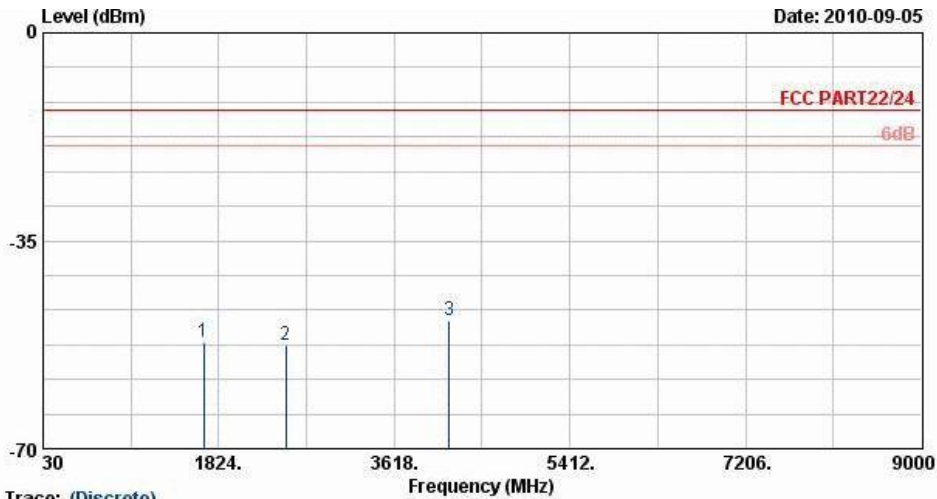

Trace: (Discrete)
 Site : 03CH07-RV
 Condition : FCC PART22/24 HF-ETRP(080306) VERTICAL
 Project : RC 081915-02

| Frequency (MHz) | ERP (dBm) | Limit (dBm) | Over Limit (dB) | SPA Reading (dBm) | S.G. Power (dBm) | TX Cable loss (dB) | TX Antenna Gain (dBi) | Polarization (H/V) | Result |
|-------------------|-------------|---------------|-------------------|---------------------|--------------------|----------------------|-------------------------|----------------------|--------|
| 1669 | -52.12 | -13 | -39.12 | -61.67 | -53.84 | 1.62 | 5.49 | V | Pass |
| 2509 | -52.60 | -13 | -39.60 | -66.6 | -54.57 | 2.1 | 6.22 | V | Pass |
| 4182 | -48.35 | -13 | -35.35 | -66.13 | -52.89 | 2.52 | 9.21 | V | Pass |



| | | | |
|------------------------|--|----------------------------|------------|
| Band : | GSM1900 | Temperature : | 25~26°C |
| Test Mode : | GSM Link | Relative Humidity : | 48~51% |
| Test Engineer : | Cona Huang | Polarization : | Horizontal |
| Remark : | Spurious emissions within 30-1000MHz were found more than 20dB below limit line. | | |



Trace: (Discrete)
 Site : 03CH07-RY
 Condition : FCC PART22/24 HF-ETRP(080306) HORIZONTAL
 Project : RC 081915-02

| Frequency (MHz) | EIRP (dBm) | Limit (dBm) | Over Limit (dB) | SPA Reading (dBm) | S.G. Power (dBm) | TX Cable loss (dB) | TX Antenna Gain (dBi) | Polarization (H/V) | Result |
|-----------------|------------|-------------|-----------------|-------------------|------------------|--------------------|-----------------------|--------------------|--------|
| 3760 | -44.96 | -13 | -31.96 | -61.06 | -51.26 | 2.51 | 8.81 | H | Pass |
| 5636 | -45.81 | -13 | -32.81 | -66.99 | -53.52 | 2.99 | 10.70 | H | Pass |
| 11280 | -37.21 | -13 | -24.21 | -67.56 | -46.25 | 4.27 | 13.31 | H | Pass |



| | | | |
|------------------------|--|----------------------------|----------|
| Band : | GSM1900 | Temperature : | 25~26°C |
| Test Mode : | GSM Link | Relative Humidity : | 48~51% |
| Test Engineer : | Cona Huang | Polarization : | Vertical |
| Remark : | Spurious emissions within 30-1000MHz were found more than 20dB below limit line. | | |

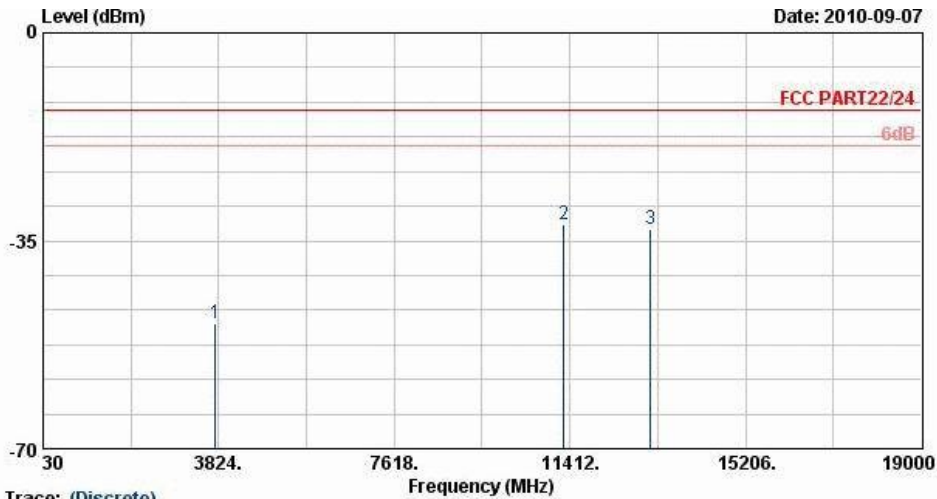

Trace: (Discrete)
 Site : 03CH07-RV
 Condition : FCC PART22/24 HF-ETRP(080306) VERTICAL
 Project : RC 081915-02

| Frequency (MHz) | EIRP (dBm) | Limit (dBm) | Over Limit (dB) | SPA Reading (dBm) | S.G. Power (dBm) | TX Cable loss (dB) | TX Antenna Gain (dBi) | Polarization (H/V) | Result |
|-------------------|--------------|---------------|-------------------|---------------------|--------------------|----------------------|-------------------------|----------------------|--------|
| 3760 | -48.86 | -13 | -35.86 | -65.94 | -55.16 | 2.51 | 8.81 | V | Pass |
| 11280 | -32.21 | -13 | -19.21 | -62.36 | -41.25 | 4.27 | 13.31 | V | Pass |
| 13160 | -33.14 | -13 | -20.14 | -65.74 | -42.66 | 4.27 | 13.79 | V | Pass |



| | | | |
|------------------------|--|----------------------------|------------|
| Band : | GSM1900 | Temperature : | 25~26°C |
| Test Mode : | EDGE 8 Link | Relative Humidity : | 48~51% |
| Test Engineer : | Cona Huang | Polarization : | Horizontal |
| Remark : | Spurious emissions within 30-1000MHz were found more than 20dB below limit line. | | |

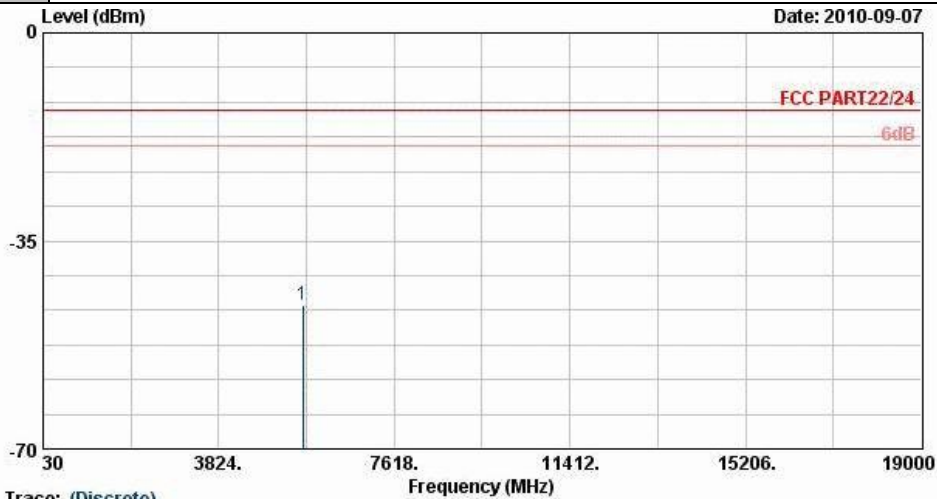

Trace: (Discrete)
 Site : 03CH07-HY
 Condition : FCC PART22/24 HF-ETRP(080306) HORIZONTAL
 Project : FG DR1915-02

| Frequency (MHz) | EIRP (dBm) | Limit (dBm) | Over Limit (dB) | SPA Reading (dBm) | S.G. Power (dBm) | TX Cable loss (dB) | TX Antenna Gain (dBi) | Polarization (H/V) | Result |
|----------------------|-----------------|------------------|-------------------------|---------------------------|--------------------------|----------------------------|-------------------------------|-------------------------|--------|
| 5636 | -45.78 | -13 | -32.78 | -66.99 | -53.49 | 2.99 | 10.70 | H | Pass |



| | | | |
|------------------------|--|----------------------------|----------|
| Band : | GSM1900 | Temperature : | 25~26°C |
| Test Mode : | EDGE 8 Link | Relative Humidity : | 48~51% |
| Test Engineer : | Cona Huang | Polarization : | Vertical |
| Remark : | Spurious emissions within 30-1000MHz were found more than 20dB below limit line. | | |



Trace: (Discrete)
 Site : 03CH07-RY
 Condition : FCC PART22/24 HF-ETRP(080306) VERTICAL
 Project : RG 081915-02

| Frequency (MHz) | EIRP (dBm) | Limit (dBm) | Over Limit (dB) | SPA Reading (dBm) | S.G. Power (dBm) | TX Cable loss (dB) | TX Antenna Gain (dBi) | Polarization (H/V) | Result |
|----------------------|-----------------|------------------|-------------------------|---------------------------|--------------------------|----------------------------|-------------------------------|-------------------------|--------|
| 7520 | -38.98 | -13 | -25.98 | -67.3 | -47.51 | 3.59 | 12.12 | V | Pass |



| | | | |
|------------------------|--|----------------------------|------------|
| Band : | WCDMA Band V | Temperature : | 25~26°C |
| Test Mode : | RMC 12.2Kbps Link | Relative Humidity : | 48~51% |
| Test Engineer : | Cona Huang | Polarization : | Horizontal |
| Remark : | Spurious emissions within 30-1000MHz were found more than 20dB below limit line. | | |

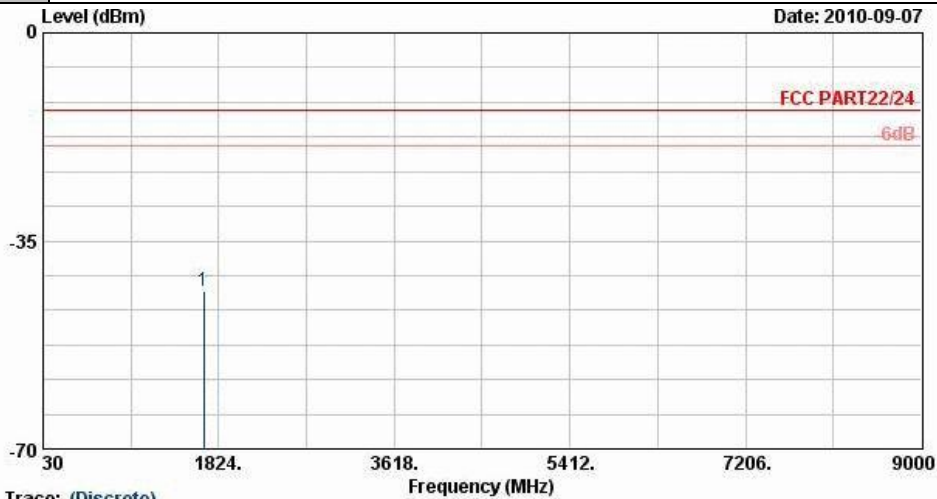

Trace: (Discrete)
 Site : 03CH07-HY
 Condition : FCC PART22/24 HF-ETRP(080306) HORIZONTAL
 Project : FG 081915-02

| Frequency (MHz) | ERP (dBm) | Limit (dBm) | Over Limit (dB) | SPA Reading (dBm) | S.G. Power (dBm) | TX Cable loss (dB) | TX Antenna Gain (dBi) | Polarization (H/V) | Result |
|-----------------|-----------|-------------|-----------------|-------------------|------------------|--------------------|-----------------------|--------------------|--------|
| 1669 | -43.56 | -13 | -30.56 | -54.17 | -45.28 | 1.62 | 5.49 | H | Pass |



| | | | |
|------------------------|--|----------------------------|----------|
| Band : | WCDMA Band V | Temperature : | 25~26°C |
| Test Mode : | RMC 12.2Kbps Link | Relative Humidity : | 48~51% |
| Test Engineer : | Cona Huang | Polarization : | Vertical |
| Remark : | Spurious emissions within 30-1000MHz were found more than 20dB below limit line. | | |

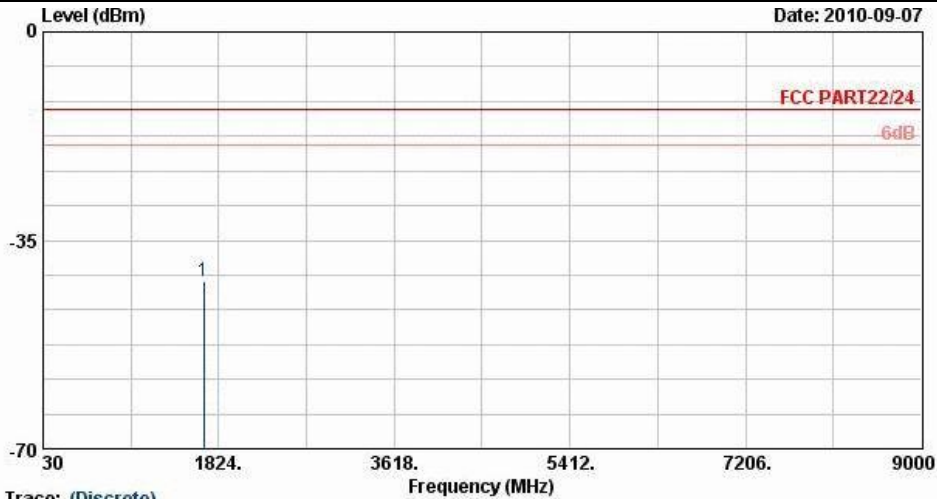

Trace: (Discrete)
 Site : 03CH07-HY
 Condition : FCC PART22/24 HF-ETRP(080306) VERTICAL
 Project : RG 081915-02

| Frequency (MHz) | ERP (dBm) | Limit (dBm) | Over Limit (dB) | SPA Reading (dBm) | S.G. Power (dBm) | TX Cable loss (dB) | TX Antenna Gain (dBi) | Polarization (H/V) | Result |
|-----------------|-----------|-------------|-----------------|-------------------|------------------|--------------------|-----------------------|--------------------|--------|
| 1669 | -41.80 | -13 | -28.80 | -53.6 | -43.52 | 1.62 | 5.49 | V | Pass |



| | | | |
|------------------------|--|----------------------------|------------|
| Band : | WCDMA Band II | Temperature : | 25~26°C |
| Test Mode : | RMC 12.2Kbps Link | Relative Humidity : | 48~51% |
| Test Engineer : | Cona Huang | Polarization : | Horizontal |
| Remark : | Spurious emissions within 30-1000MHz were found more than 20dB below limit line. | | |

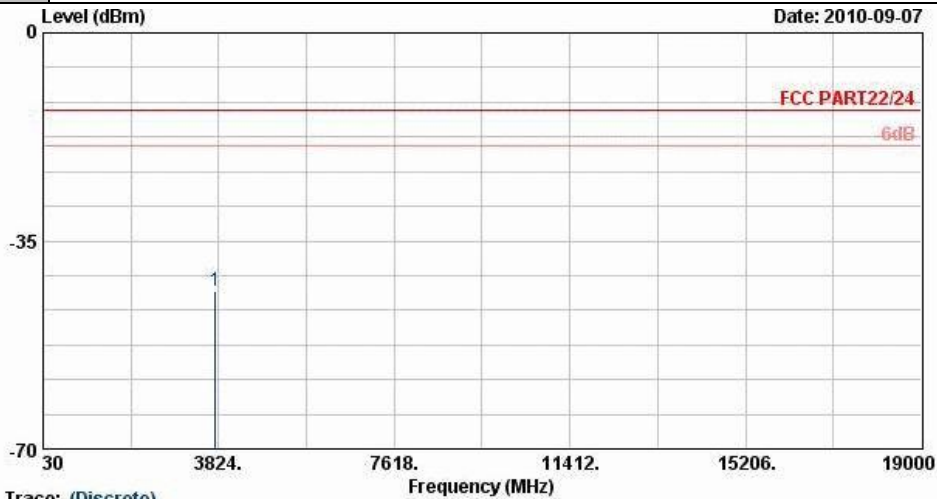

Trace: (Discrete)
 Site : 03CH07-HY
 Condition : FCC PART22/24 HF-ETRP(080306) HORIZONTAL
 Project : FG 081915-02

| Frequency (MHz) | EIRP (dBm) | Limit (dBm) | Over Limit (dB) | SPA Reading (dBm) | S.G. Power (dBm) | TX Cable loss (dB) | TX Antenna Gain (dBi) | Polarization (H/V) | Result |
|-----------------|------------|-------------|-----------------|-------------------|------------------|--------------------|-----------------------|--------------------|--------|
| 3760 | -43.44 | -13 | -30.44 | -59.62 | -49.74 | 2.51 | 8.81 | H | Pass |



| | | | |
|------------------------|--|----------------------------|----------|
| Band : | WCDMA Band II | Temperature : | 25~26°C |
| Test Mode : | RMC 12.2Kbps Link | Relative Humidity : | 48~51% |
| Test Engineer : | Cona Huang | Polarization : | Vertical |
| Remark : | Spurious emissions within 30-1000MHz were found more than 20dB below limit line. | | |



Trace: (Discrete)
 Site : 03CH07-RY
 Condition : FCC PART22/24 HF-ETRP(080306) VERTICAL
 Project : RG 081915-02

| Frequency (MHz) | EIRP (dBm) | Limit (dBm) | Over Limit (dB) | SPA Reading (dBm) | S.G. Power (dBm) | TX Cable loss (dB) | TX Antenna Gain (dBi) | Polarization (H/V) | Result |
|-----------------|------------|-------------|-----------------|-------------------|------------------|--------------------|-----------------------|--------------------|--------|
| 3760 | -47.06 | -13 | -34.06 | -65 | -53.36 | 2.51 | 8.81 | V | Pass |

3.7 Frequency Stability Measurement

3.7.1 Description of Frequency Stability Measurement

The frequency stability shall be measured by variation of ambient temperature and variation of primary supply voltage to ensure that the fundamental emission stays within the authorized frequency block. The frequency stability of the transmitter shall be maintained within $\pm 0.00025\%$ ($\pm 2.5\text{ppm}$) of the center frequency.

3.7.2 Measuring Instruments

See list of measuring instruments of this test report.

3.7.3 Test Procedures for Temperature Variation

1. The EUT was set up in the thermal chamber and connected with the base station.
2. With power OFF, the temperature was decreased to -30°C and the EUT was stabilized for three hours. Power was applied and the maximum change in frequency was recorded within one minute.
3. With power OFF, the temperature was raised in 10°C step up to 50°C . The EUT was stabilized at each step for at least half an hour. Power was applied and the maximum frequency change was recorded within one minute.
4. If the EUT can not be turned on at -30°C , the testing lowest temperature will be raised in 10°C step until the EUT can be turned on.

3.7.4 Test Procedures for Voltage Variation

1. The EUT was placed in a temperature chamber at $25\pm 5^{\circ}\text{C}$ and connected with the base station.
2. The power supply voltage to the EUT was varied from BEP to 115% of the nominal value measured at the input to the EUT.
3. The variation in frequency was measured for the worst case.

3.7.5 Test Setup

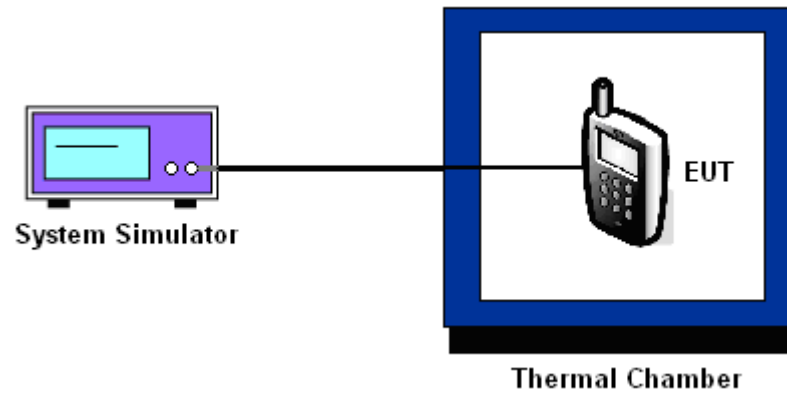



3.7.6 Test Result of Temperature Variation

| | | | |
|---------------|---------|-----------|-----|
| Band : | GSM 850 | Channel : | 189 |
| Limit (ppm) : | 2.5 | | |

| Temperature (°C) | GSM | | EDGE 8 | | Result |
|------------------|-----------------|-----------------|-----------------|-----------------|--------|
| | Freq. Dev. (Hz) | Deviation (ppm) | Freq. Dev. (Hz) | Deviation (ppm) | |
| -30 | N/A | N/A | N/A | N/A | PASS |
| -20 | -35 | -0.04 | 64 | 0.08 | |
| -10 | -30 | -0.04 | -44 | -0.05 | |
| 0 | 37 | 0.04 | 59 | 0.07 | |
| 10 | 48 | 0.06 | 36 | 0.04 | |
| 20 | -15 | -0.02 | 12 | 0.01 | |
| 30 | 21 | 0.02 | 22 | 0.03 | |
| 40 | -47 | -0.06 | 38 | 0.04 | |
| 50 | 34 | 0.04 | -55 | -0.06 | |

Note:

- 1. The EUT stops transmitting at temperature -30°C.
- 2. The manufacturer declared that the EUT could work properly between temperatures -20°C~55°C.



| | | | |
|---------------|----------|-----------|-----|
| Band : | GSM 1900 | Channel : | 661 |
| Limit (ppm) : | 2.5 | | |

| Temperature (°C) | GSM | | EDGE 8 | | Result |
|------------------|-----------------|-----------------|-----------------|-----------------|--------|
| | Freq. Dev. (Hz) | Deviation (ppm) | Freq. Dev. (Hz) | Deviation (ppm) | |
| -30 | N/A | N/A | N/A | N/A | PASS |
| -20 | 63 | 0.03 | 28 | 0.01 | |
| -10 | -58 | -0.03 | 37 | 0.02 | |
| 0 | 47 | 0.02 | 44 | 0.02 | |
| 10 | 32 | 0.02 | -17 | -0.01 | |
| 20 | 22 | 0.01 | 33 | 0.02 | |
| 30 | -43 | -0.02 | 20 | 0.01 | |
| 40 | 56 | 0.03 | 27 | 0.01 | |
| 50 | 42 | 0.02 | -31 | -0.02 | |

Note:

1. The EUT stops transmitting at temperature -30°C.
2. The manufacturer declared that the EUT could work properly between temperatures -20°C~55°C.



| | | | |
|---------------|--------------|-----------|------|
| Band : | WCDMA Band V | Channel : | 4182 |
| Limit (ppm) : | 2.5 | | |

| Temperature (°C) | RMC 12.2Kbps | | Result |
|------------------|-----------------|-----------------|--------|
| | Freq. Dev. (Hz) | Deviation (ppm) | |
| -30 | N/A | N/A | PASS |
| -20 | -18 | -0.02 | |
| -10 | 44 | 0.05 | |
| 0 | 34 | 0.04 | |
| 10 | -46 | -0.05 | |
| 20 | 13 | 0.02 | |
| 30 | 33 | 0.04 | |
| 40 | 27 | 0.03 | |
| 50 | 20 | 0.02 | |

Note:

1. The EUT stops transmitting at temperature -30°C.
2. The manufacturer declared that the EUT could work properly between temperatures -20°C~55°C.



| | | | |
|---------------|---------------|-----------|------|
| Band : | WCDMA Band II | Channel : | 9400 |
| Limit (ppm) : | 2.5 | | |

| Temperature (°C) | RMC 12.2Kbps | | Result |
|------------------|-----------------|-----------------|--------|
| | Freq. Dev. (Hz) | Deviation (ppm) | |
| -30 | N/A | N/A | PASS |
| -20 | -80 | -0.04 | |
| -10 | 31 | 0.02 | |
| 0 | 66 | 0.03 | |
| 10 | -43 | -0.02 | |
| 20 | 13 | 0.01 | |
| 30 | 24 | 0.01 | |
| 40 | 41 | 0.02 | |
| 50 | 53 | 0.03 | |

Note:

1. The EUT stops transmitting at temperature -30°C.
2. The manufacturer declared that the EUT could work properly between temperatures -20°C~55°C.



3.7.7 Test Result of Voltage Variation

| Band & Channel | Mode | Voltage (Volt) | Freq. Dev. (Hz) | Deviation (ppm) | Limit (ppm) | Result |
|-------------------------|-----------------|----------------|-----------------|-----------------|-------------|--------|
| GSM 850 CH189 | GSM | 3.8 | -71 | -0.08 | 2.5 | PASS |
| | | BEP | -87 | -0.10 | | |
| | | 4.2 | -48 | -0.06 | | |
| | EDGE 8 | 3.8 | -56 | -0.07 | | |
| | | BEP | 79 | 0.09 | | |
| | | 4.2 | 50 | 0.06 | | |
| GSM 1900 CH661 | GSM | 3.8 | 48 | 0.03 | | |
| | | BEP | 50 | 0.03 | | |
| | | 4.2 | 42 | 0.02 | | |
| | EDGE 8 | 3.8 | 39 | 0.02 | | |
| | | BEP | -62 | -0.03 | | |
| | | 4.2 | 41 | 0.02 | | |
| WCDMA Band V CH4182 | RMC 12.2Kbps | 3.8 | 9 | 0.01 | | |
| | | BEP | -14 | -0.02 | | |
| | | 4.2 | -11 | -0.01 | | |
| WCDMA Band II CH9400 | RMC 12.2Kbps | 3.8 | 21 | 0.01 | | |
| | | BEP | 15 | 0.01 | | |
| | | 4.2 | -22 | -0.01 | | |

Note:

1. Normal Voltage = 3.8V.
2. Battery End Point (BEP) = 3.6 V.



4 List of Measuring Equipment

| Instrument | Manufacturer | Model No. | Serial No. | Characteristics | Calibration Date | Due Date | Remark |
|---------------------------|--------------|-----------|-----------------|--------------------------|------------------|---------------|-----------------------|
| System Simulator | R&S | CMU200 | 117995 | N/A | Mar. 19, 2009 | Mar. 18, 2011 | Conducted (TH02-HY) |
| Spectrum Analyzer | R&S | FSP30 | 101329 | 9kHz~30GHz | Apr. 26, 2010 | Apr. 25, 2011 | Conducted (TH02-HY) |
| Thermal Chamber | Ten Billion | TTH-D35P | TBN-930701 | N/A | Jul. 30,2010 | Jul. 29, 2011 | Conducted (TH02-HY) |
| Bilog Antenna | SCHAFFNER | CBL6111C | 2726 | 30MHz ~ 1GHz | Oct. 31, 2009 | Oct. 30, 2010 | Radiation (03CH07-HY) |
| Spectrum Analyzer | R&S | FSP | 101067 | 9KHz ~ 30GHz | Dec. 04, 2009 | Dec. 03, 2010 | Radiation (03CH07-HY) |
| Double Ridge Horn Antenna | ESCO | 3117 | 00075962 | 1GHz ~ 18GHz | Aug. 19, 2010 | Aug. 18, 2011 | Radiation (03CH07-HY) |
| SHF-EHF Horn Antenna | SCHWARZBECK | BBHA 9170 | BBHA917025 1 | 15GHz- 40GHz | Oct. 14, 2009 | Oct. 13, 2010 | Radiation (03CH07-HY) |
| Pre Amplifier | Agilent | 8449B | 3008A02362 | 1GHz~ 26.5GHz | Dec.09,2009 | Dec. 08, 2010 | Radiation (03CH07-HY) |
| Pre Amplifier | COM-POWER | PA-103A | 161241 | 10-1000MHz.32dB. GAIN | Mar. 27, 2010 | Mar. 26, 2011 | Radiation (03CH07-HY) |
| Loop Antenna | R&S | HFH2-Z2 | 860004/001 | 9 kHz~30 MHz | Jul. 29, 2010 | Jul. 28, 2011 | Radiation (03CH07-HY) |
| System Simulator | R&S | CMU200 | 117997 | N/A | May 14, 2009 | May 13, 2011 | Radiation (03CH07-HY) |

5 Uncertainty of Evaluation

Uncertainty of Radiated Emission Measurement (30 MHz ~ 1000 MHz)

| Contribution | Uncertainty of X_i | | $u(X_i)$ |
|--|----------------------|--------------------------|----------|
| | dB | Probability Distribution | |
| Receiver Reading | 0.41 | Normal (k=2) | 0.21 |
| Antenna Factor Calibration | 0.83 | Normal (k=2) | 0.42 |
| Cable Loss Calibration | 0.25 | Normal (k=2) | 0.13 |
| Pre-Amplifier Gain Calibration | 0.27 | Normal (k=2) | 0.14 |
| RCV/SPA Specification | 2.50 | Rectangular | 0.72 |
| Antenna Factor Interpolation for Frequency | 1.00 | Rectangular | 0.29 |
| Site Imperfection | 1.43 | Rectangular | 0.83 |
| Mismatch | +0.39 / -0.41 | U-Shape | 0.28 |
| Combined Standard Uncertainty $U_c(y)$ | 1.27 | | |
| Measuring Uncertainty for a Level of Confidence of 95% ($U = 2U_c(y)$) | 2.54 | | |

Uncertainty of Radiated Emission Measurement (1 GHz ~ 40 GHz)

| Contribution | Uncertainty of X_i | | $u(X_i)$ | C_i | $C_i * u(X_i)$ |
|--|----------------------|--------------------------|----------|-------|----------------|
| | dB | Probability Distribution | | | |
| Receiver Reading | ± 0.10 | Normal (k=2) | 0.10 | 1 | 0.10 |
| Antenna Factor Calibration | ± 1.70 | Normal (k=2) | 0.85 | 1 | 0.85 |
| Cable Loss Calibration | ± 0.50 | Normal (k=2) | 0.25 | 1 | 0.25 |
| Receiver Correction | ± 2.00 | Rectangular | 1.15 | 1 | 1.15 |
| Antenna Factor Directional | ± 1.50 | Rectangular | 0.87 | 1 | 0.87 |
| Site Imperfection | ± 2.80 | Triangular | 1.14 | 1 | 1.14 |
| Mismatch Receiver VSWR $\Gamma_1 = 0.197$ Antenna VSWR $\Gamma_2 = 0.194$ Uncertainty = $20\text{Log}(1-\Gamma_1*\Gamma_2)$ | +0.34 / -0.35 | U-Shape | 0.244 | 1 | 0.244 |
| Combined Standard Uncertainty $U_c(y)$ | 2.36 | | | | |
| Measuring Uncertainty for a Level of Confidence of 95% ($U = 2U_c(y)$) | 4.72 | | | | |



Appendix A. Photographs of EUT

Please refer to Sporton report number EP081915-02 as below.