



FCC RF Test Report

APPLICANT : Acer Incorporated
EQUIPMENT : Smart HandHeld
BRAND NAME : Acer
MODEL NAME : T01, TM01
MARKETING NAME : Liquid Z330, Liquid M330
FCC ID : HLZDMZ330
STANDARD : FCC 47 CFR Part 2, 22(H), 24(E), 27(L)
CLASSIFICATION : PCS Licensed Transmitter Held to Ear (PCE)

The product was received on Jul. 14, 2015 and testing was completed on Sep. 30, 2015. We, SPORTON INTERNATIONAL (KUNSHAN) INC., would like to declare that the tested sample has been evaluated in accordance with the test procedures given in ANSI / TIA / EIA-603-C-2004 and has been in compliance with the applicable technical standards.

The test results in this report apply exclusively to the tested model / sample. Without written approval of SPORTON INTERNATIONAL (KUNSHAN) INC., the test report shall not be reproduced except in full.

Reviewed by: Joseph Lin / Supervisor

Approved by: Jones Tsai / Manager



SPORTON INTERNATIONAL (KUNSHAN) INC.
No. 3-2, PingXiang Road, Kunshan, Jiangsu Province, P. R. China



TABLE OF CONTENTS

REVISION HISTORY..... 3

SUMMARY OF TEST RESULT 4

1 GENERAL DESCRIPTION 5

 1.1 Applicant..... 5

 1.2 Manufacturer 5

 1.3 Product Feature of Equipment Under Test 5

 1.4 Product Specification subjective to this standard..... 6

 1.5 Modification of EUT 7

 1.6 Maximum ERP/EIRP Power, Frequency Tolerance, and Emission Designator 7

 1.7 Testing Location 8

 1.8 Applicable Standards 8

2 TEST CONFIGURATION OF EQUIPMENT UNDER TEST 9

 2.1 Test Mode..... 9

 2.2 Connection Diagram of Test System 12

 2.3 Support Unit used in test configuration 12

 2.4 Measurement Results Explanation Example 12

3 TEST RESULT 13

 3.1 Conducted Output Power Measurement..... 13

 3.2 Peak-to-Average Ratio 15

 3.3 Effective Radiated Power and Effective Isotropic Radiated Power Measurement 31

 3.4 99% Occupied Bandwidth and 26dB Bandwidth Measurement..... 35

 3.5 Band Edge Measurement..... 59

 3.6 Conducted Spurious Emission Measurement 74

 3.7 Field Strength of Spurious Radiation Measurement 96

 3.8 Frequency Stability Measurement..... 119

4 LIST OF MEASURING EQUIPMENT 125

5 UNCERTAINTY OF EVALUATION 126

APPENDIX A. SETUP PHOTOGRAPHS



REVISION HISTORY

REPORT NO.	VERSION	DESCRIPTION	ISSUED DATE
FG571424A	Rev. 01	Initial issue of report	Oct. 13, 2015



SUMMARY OF TEST RESULT

Report Section	FCC Rule	IC Rule	Description	Limit	Result	Remark
3.1	§2.1046	RSS-132 (5.4) RSS-133 (6.4) RSS-139 (6.5)	Conducted Output Power	Reporting Only	PASS	-
3.2	§24.232(d)	RSS-132 (5.4) RSS-133 (6.4) RSS-139 (6.4)	Peak-to-Average Ratio	< 13 dB	PASS	-
3.3	§22.913(a)(2)	RSS-132(5.4) SRSP-503(5.1.3)	Effective Radiated Power	< 7 Watts	PASS	-
	§24.232(c)	RSS-133 (6.4) SRSP-510(5.1.2)	Equivalent Isotropic Radiated Power	< 2 Watts	PASS	-
	§27.50(d)(4)	RSS-139 (6.5) SRSP-513(5.1.2)	Equivalent Isotropic Radiated Power	< 1 Watts	PASS	-
3.4	§2.1049	RSS-GEN(6.6) RSS-133(6.5) RSS-139 (3.1)	Occupied Bandwidth	Reporting Only	PASS	-
3.5	§2.1051 §22.917(a) §24.238(a) §27.53(h)	RSS-132 (5.5) RSS-133 (6.5) RSS-139 (6.6)	Band Edge Measurement	< 43+10log10(P[Watts])	PASS	-
3.6	§2.1051 §22.917(a) §24.238(a) §27.53(h)	RSS-132 (5.5) RSS-133 (6.5) RSS-139 (6.6)	Conducted Emission	< 43+10log10(P[Watts])	PASS	-
3.7	§2.1053 §22.917(a) §24.238(a) §27.53(h)	RSS-132 (5.5) RSS-133 (6.5) RSS-139 (6.6)	Field Strength of Spurious Radiation	< 43+10log10(P[Watts])	PASS	Under limit 23.03 dB at 5556.000 MHz
3.8	§2.1055 §22.355	RSS-GEN(6.11) RSS-132 (5.3)	Frequency Stability for Temperature & Voltage	< 2.5 ppm for Part 22 Within Authorized Band	PASS	-
	§2.1055 §24.235 §27.54	RSS-GEN(6.11) RSS-133 (6.3) RSS-139 (6.4)				

1 General Description

1.1 Applicant

Acer Incorporated

8F., No. 88, Sec. 1, Xintai 5th Rd., Xizhi Dist., New Taipei City 22181, Taiwan (R.O.C)

1.2 Manufacturer

Shanghai HuaQin Telecom Technology CO., LTD

Building 1, No.399, Keyuan Road, High-tech Park PudongZhangjiang, Shanghai, China

1.3 Product Feature of Equipment Under Test

Product Feature	
Equipment	Smart HandHeld
Brand Name	Acer
Model Name	T01, TM01
Marketing Name	Liquid Z330, Liquid M330
FCC ID	HLZDMZ330
EUT supports Radios application	GSM/GPRS/EGPRS/WCDMA/HSPA/HSPA+(Downlink Only)/DC-HSDPA/LTE WLAN2.4GHz 802.11b/g/n HT20 Bluetooth v3.0+EDR Bluetooth v4.0 LE
IMEI Code	Conducted: 352921070004206/352921070006680 Radiation: 352921070004123/352921070006607 ERP/EIRP: 352921070004321/352921070006805
EUT Stage	Identical Prototype

Remark:

1. The above EUT's information was declared by manufacturer. Please refer to the specifications or user's manual for more detailed description.
2. There are two types of EUT sample 1 and sample 2, the differences between two samples are only for SIM slot, sample 1 is dual SIM slot, sample 2 is single SIM slot.



1.4 Product Specification subjective to this standard

Product Specification subjective to this standard	
Tx Frequency	GSM850: 824.2 MHz ~ 848.8 MHz GSM1900: 1850.2 MHz ~ 1909.8MHz WCDMA Band V: 826.4 MHz ~ 846.6 MHz WCDMA Band IV : 1712.4 MHz ~ 1752.6 MHz WCDMA Band II: 1852.4 MHz ~ 1907.6 MHz
Rx Frequency	GSM850: 869.2 MHz ~ 893.8 MHz GSM1900: 1930.2 MHz ~ 1989.8 MHz WCDMA Band V: 871.4 MHz ~ 891.6 MHz WCDMA Band IV : 2112.4 MHz ~ 2152.6 MHz WCDMA Band II: 1932.4 MHz ~ 1987.6 MHz
Maximum Output Power to Antenna	GSM850 : 33.02 dBm GSM1900 : 28.76 dBm WCDMA Band V : 22.41 dBm WCDMA Band IV : 21.19 dBm WCDMA Band II : 21.81 dBm
Antenna Type	Loop Antenna
Type of Modulation	GSM: GMSK GPRS: GMSK EDGE: GMSK / 8PSK WCDMA: QPSK (Uplink) HSDPA / DC-HSDPA: QPSK (Uplink) HSUPA: QPSK (Uplink) HSPA+: 16QAM (Downlink Only) DC-HSDPA: 64QAM



1.5 Modification of EUT

No modifications are made to the EUT during all test items.

1.6 Maximum ERP/EIRP Power, Frequency Tolerance, and Emission Designator

FCC Rule	System	Type of Modulation	Maximum ERP/EIRP (W)	Frequency Tolerance (ppm)	Emission Designator
Part 22	GSM850 GSM	GMSK	1.0304	0.0550 ppm	246KGXW
Part 22	GSM850 EDGE class 8	8PSK	0.2985	0.0514 ppm	246KG7W
Part 22	WCDMA Band V RMC 12.2Kbps	QPSK	0.0789	0.0466 ppm	4M16F9W
Part 24	GSM1900 GSM	GMSK	1.6181	0.0234 ppm	248KGXW
Part 24	GSM1900 EDGE class 8	8PSK	0.7261	0.0213 ppm	248KG7W
Part 24	WCDMA Band II RMC 12.2Kbps	QPSK	0.2992	0.0271 ppm	4M16F9W
Part 27	WCDMA Band IV RMC 12.2Kbps	QPSK	0.3420	0.0387 ppm	4M16F9W



1.7 Testing Location

Test Site	SPORTON INTERNATIONAL (KUNSHAN) INC.		
Test Site Location	No. 3-2, PingXiang Road, Kunshan, Jiangsu Province, P. R. China TEL: +86-0512-5790-0158 FAX: +86-0512-5790-0958		
Test Site No.	Sporton Site No.		FCC/IC Registration No.
	TH01-KS	03CH02-KS	418269/4086E

Note: The test site complies with ANSI C63.4 2009 requirement.

1.8 Applicable Standards

According to the specifications of the manufacturer, the EUT must comply with the requirements of the following standards:

- ♦ 47 CFR Part 2, 22(H), 24(E), 27(L)
- ♦ ANSI / TIA / EIA-603-C-2004
- ♦ FCC KDB 971168 D01 Power Meas. License Digital Systems v02r02
- ♦ IC RSS-132 Issue 3
- ♦ IC RSS-133 Issue 6
- ♦ IC RSS-139 Issue 3
- ♦ IC RSS-Gen Issue 4

Remark:

1. All test items were verified and recorded according to the standards and without any deviation during the test.
2. This EUT has also been tested and complied with the requirements of FCC Part 15, Subpart B, recorded in a separate test report.



2 Test Configuration of Equipment Under Test

2.1 Test Mode

Antenna port conducted and radiated test items were performed according to KDB 971168 D01 Power Meas. License Digital Systems v02r02 with maximum output power.

Radiated measurements were performed with rotating EUT in different three orthogonal test planes to find the maximum emission.

Radiated emissions were investigated as following frequency range:

1. 30 MHz to 10th harmonic for GSM850 and WCDMA Band V.
2. 30 MHz to 10th harmonic for WCDMA Band IV
3. 30 MHz to 10th harmonic for GSM1900 and WCDMA Band II.

All modes and data rates and positions were investigated.

Test modes are chosen to be reported as the worst case configuration below:

Test Modes		
Band	Radiated TCs	Conducted TCs
GSM 850	<ul style="list-style-type: none"> ■ GSM Link ■ EDGE class 8 Link 	<ul style="list-style-type: none"> ■ GSM Link ■ EDGE class 8 Link
GSM 1900	<ul style="list-style-type: none"> ■ GSM Link ■ EDGE class 8 Link 	<ul style="list-style-type: none"> ■ GSM Link ■ EDGE class 8 Link
WCDMA Band V	<ul style="list-style-type: none"> ■ RMC 12.2Kbps Link 	<ul style="list-style-type: none"> ■ RMC 12.2Kbps Link
WCDMA Band II	<ul style="list-style-type: none"> ■ RMC 12.2Kbps Link 	<ul style="list-style-type: none"> ■ RMC 12.2Kbps Link
WCDMA Band IV	<ul style="list-style-type: none"> ■ RMC 12.2Kbps Link 	<ul style="list-style-type: none"> ■ RMC 12.2Kbps Link

Note: The maximum power levels are chosen to test as the worst case configuration as follows:

GSM mode for GMSK modulation,

EDGE multi-slot class 8 mode for 8PSK modulation,

RMC 12.2Kbps mode for WCDMA band V and WCDMA band IV,

RMC 12.2Kbps mode for WCDMA band II, only these modes were used for all tests.



Conducted Power Measurement Results:

SIM 1:

Conducted Power (*Unit: dBm)						
Band	GSM850			GSM1900		
Channel	128	189	251	512	661	810
Frequency	824.2	836.4	848.8	1850.2	1880.0	1909.8
GSM	32.96	33.02	32.98	28.62	28.69	28.76
GPRS class 8	32.92	32.98	32.96	28.60	28.66	28.75
GPRS class 10	30.05	30.15	30.13	25.91	26.13	26.36
GPRS class 11	28.61	28.63	28.67	24.73	24.75	24.81
GPRS class 12	26.56	26.61	26.63	22.55	22.62	22.83
EGPRS class 8	26.75	26.71	26.77	25.14	25.23	25.45
EGPRS class 10	26.26	26.21	26.18	23.95	24.03	24.25
EGPRS class 11	25.38	25.34	25.31	23.55	23.63	23.95
EGPRS class 12	23.25	23.20	23.18	20.87	20.88	21.06

Conducted Power (*Unit: dBm)									
Band	WCDMA Band V			WCDMA Band II			WCDMA Band IV		
Channel	4132	4182	4233	9262	9400	9538	1312	1413	1513
Frequency	826.4	836.4	846.6	1852.4	1880	1907.6	1712.4	1732.6	1752.6
AMR 12.2K	22.15	22.20	22.38	21.60	21.80	21.73	21.10	21.06	21.18
RMC 12.2K	22.16	22.23	22.41	21.62	21.81	21.78	21.11	21.08	21.19
HSDPA Subtest-1	21.19	21.23	21.35	20.16	20.22	20.19	19.63	19.59	19.68
HSDPA Subtest-2	21.21	21.22	21.30	20.13	20.21	20.18	19.62	19.58	19.66
HSDPA Subtest-3	20.74	20.74	20.87	20.12	20.20	20.18	19.65	19.60	19.73
HSDPA Subtest-4	20.71	20.77	20.79	20.14	20.21	20.20	19.70	19.58	19.71
DC-HSDPA Subtest-1	20.56	20.61	20.72	20.05	20.26	20.41	19.08	19.04	19.13
DC-HSDPA Subtest-2	20.55	20.61	20.76	20.11	20.29	20.43	19.06	19.00	19.16
DC-HSDPA Subtest-3	20.18	20.30	20.33	19.55	19.81	19.84	18.66	18.64	18.71
DC-HSDPA Subtest-4	20.16	20.29	20.29	19.57	19.84	19.84	18.65	18.63	18.68
HSUPA Subtest-1	20.88	20.93	21.03	20.43	20.52	20.50	19.85	19.80	19.86
HSUPA Subtest-2	19.78	19.87	19.93	19.62	19.71	19.67	18.75	18.70	18.78
HSUPA Subtest-3	20.25	20.44	20.55	19.65	19.76	19.70	18.65	18.60	18.70
HSUPA Subtest-4	20.68	20.76	20.85	20.30	20.38	20.33	19.64	19.60	19.68
HSUPA Subtest-5	21.04	21.10	21.21	19.90	19.93	19.94	19.24	19.20	19.30



SIM 2:

Conducted Power (*Unit: dBm)						
Band	GSM850			GSM1900		
Channel	128	189	251	512	661	810
Frequency	824.2	836.4	848.8	1850.2	1880.0	1909.8
GSM	32.91	32.96	32.92	28.61	28.61	28.69
GPRS class 8	32.82	32.85	32.84	28.60	28.59	28.66
GPRS class 10	30.02	30.12	30.10	25.90	26.07	26.29
GPRS class 11	28.58	28.62	28.60	24.70	24.74	24.80
GPRS class 12	26.51	26.58	26.55	22.54	22.60	22.81
EGPRS class 8	26.65	26.65	26.72	25.12	25.21	25.41
EGPRS class 10	26.15	26.11	26.05	23.91	24.01	24.22
EGPRS class 11	25.37	25.21	25.28	23.54	23.60	23.93
EGPRS class 12	23.16	23.15	23.11	20.85	20.85	21.03

2.2 Connection Diagram of Test System

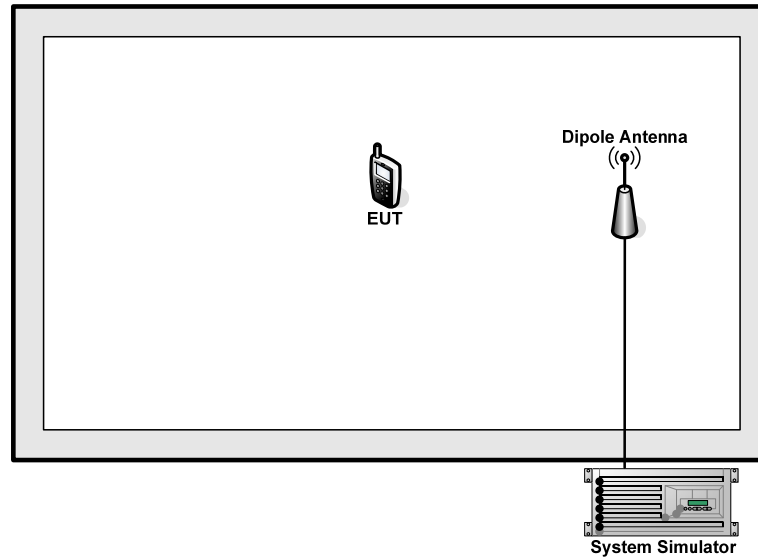

2.3 Support Unit used in test configuration

Item	Equipment	Trade Name	Model No.	FCC ID	Data Cable	Power Cord
1.	System Simulator	R&S	CMU 200	N/A	N/A	Unshielded, 1.8 m
2.	DC Power Supply	GW INSTEK	GPD-2303S	N/A	N/A	Unshielded, 1.8 m

2.4 Measurement Results Explanation Example

For all conducted test items:

The offset level is set in the spectrum analyzer to compensate the RF cable loss and attenuator factor between RF conducted output port and spectrum analyzer. With the offset compensation, the spectrum analyzer reading level will be exactly the RF output level.

The spectrum analyzer offset is derived from RF cable loss and attenuator factor.

Offset = RF cable loss + attenuator factor.

The following shows an offset computation example with RF cable loss 5.2 dB and a 10dB attenuator.

Example :

$$\begin{aligned} \text{Offset(dB)} &= \text{RF cable loss(dB)} + \text{attenuator factor(dB)}. \\ &= 5.2 + 10 = 15.2 \text{ (dB)} \end{aligned}$$

3 Test Result

3.1 Conducted Output Power Measurement

3.1.1 Description of the Conducted Output Power Measurement

A system simulator was used to establish communication with the EUT. Its parameters were set to enforce EUT transmitting at the maximum power. The measured power in the radio frequency on the transmitter output terminals shall be reported.

3.1.2 Measuring Instruments

The measuring equipment is listed in the section 4 of this test report.

3.1.3 Test Procedures

1. The transmitter output port was connected to the system simulator.
2. Set EUT at maximum power through system simulator.
3. Select lowest, middle, and highest channels for each band and different modulation.
4. Measure the maximum burst average power for GSM and maximum average power for other modulation signal.

3.1.4 Test Setup

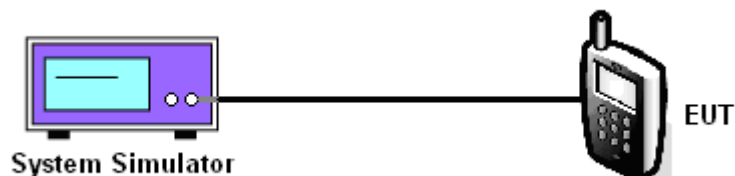

3.1.5 Test Result of Conducted Output Power

Cellular Band									
Modes	GSM850 (GSM)			GSM850 (EDGE class 8)			WCDMA Band V (RMC 12.2Kbps)		
Channel	128 (Low)	189 (Mid)	251 (High)	128 (Low)	189 (Mid)	251 (High)	4132 (Low)	4182 (Mid)	4233 (High)
Frequency (MHz)	824.2	836.4	848.8	824.2	836.4	848.8	826.4	836.4	846.6
Conducted Power (dBm)	32.96	33.02	32.98	26.75	26.71	26.77	22.16	22.23	22.41

PCS Band									
Modes	GSM1900 (GSM)			GSM1900 (EDGE class 8)			WCDMA Band II (RMC 12.2Kbps)		
Channel	512 (Low)	661 (Mid)	810 (High)	512 (Low)	661 (Mid)	810 (High)	9262 (Low)	9400 (Mid)	9538 (High)
Frequency (MHz)	1850.2	1880	1909.8	1850.2	1880	1909.8	1852.4	1880	1907.6
Conducted Power (dBm)	28.62	28.69	28.76	25.14	25.23	25.45	21.62	21.81	21.78

AWS Band			
Modes	WCDMA Band IV (RMC 12.2Kbps)		
Channel	1312(Low)	1413 (Mid)	1513 (High)
Frequency (MHz)	1712.4	1732.6	1752.6
Conducted Power (dBm)	21.11	21.08	21.19

Note: maximum burst average power for GSM, and maximum average power for WCDMA.

3.2 Peak-to-Average Ratio

3.2.1 Description of the PAR Measurement

The peak-to-average ratio (PAR) of the transmission may not exceed 13 dB.

3.2.2 Measuring Instruments

The measuring equipment is listed in the section 4 of this test report.

3.2.3 Test Procedures

1. The testing follows FCC KDB 971168 v02r02 Section 5.7.1.
2. The EUT was connected to the spectrum analyzer and system simulator via a power divider.
3. For GSM/EGPRS operating modes:
 - a. Set EUT in maximum power output.
 - b. Set the RBW = 1MHz, VBW = 3MHz, Peak detector on spectrum analyzer for first trace.
 - c. Set the RBW = 1MHz, VBW = 3MHz, RMS detector on spectrum analyzer for second trace.
 - d. The wanted burst signal is triggered by spectrum analyzer, and measured respectively the peak level and Mean level without burst-off time, after system simulator has synchronized with the spectrum analyzer.
4. For UMTS operating modes:
 - a. Set the CCDF (Complementary Cumulative Distribution Function) option on the spectrum analyzer.
 - b. The highest RF powers were measured and recorded the maximum PAPR level associated with a probability of 0.1 %.
5. Record the deviation as Peak to Average Ratio.

3.2.4 Test Setup

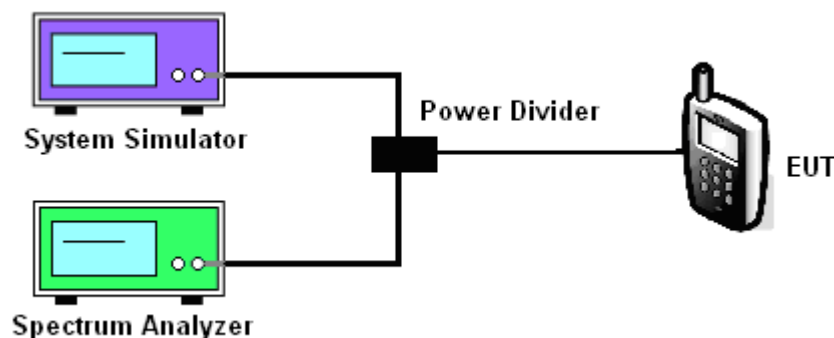



3.2.5 Test Result of Peak-to-Average Ratio

Cellular Band									
Modes	GSM850 (GSM)			GSM850 (EDGE class 8)			WCDMA Band V (RMC 12.2Kbps)		
Channel	128 (Low)	189 (Mid)	251 (High)	128 (Low)	189 (Mid)	251 (High)	4132 (Low)	4182 (Mid)	4233 (High)
Frequency (MHz)	824.2	836.4	848.8	824.2	836.4	848.8	826.4	836.4	846.6
Peak-to-Average Ratio (dB)	0.42	0.43	0.43	2.93	2.94	2.98	3.20	3.20	3.40

PCS Band									
Modes	GSM1900 (GSM)			GSM1900 (EDGE class 8)			WCDMA Band II (RMC 12.2Kbps)		
Channel	512 (Low)	661 (Mid)	810 (High)	512 (Low)	661 (Mid)	810 (High)	9262 (Low)	9400 (Mid)	9538 (High)
Frequency (MHz)	1850.2	1880	1909.8	1850.2	1880	1909.8	1852.4	1880	1907.6
Peak-to-Average Ratio (dB)	0.69	0.59	0.57	3.30	3.22	3.32	3.04	3.32	3.16

AWS Band			
Modes	WCDMA Band IV (RMC 12.2Kbps)		
Channel	1312(Low)	1413 (Mid)	1513 (High)
Frequency (MHz)	1712.4	1732.6	1752.6
Peak-to-Average Ratio (dB)	2.96	3.28	3.32



3.2.6 Test Result (Plots) of Peak-to-Average Ratio

Band :	GSM 850	Test Mode :	GSM Link (GMSK)
--------	---------	-------------	-----------------

Peak-to-Average Ratio on Channel 128 (824.2 MHz)

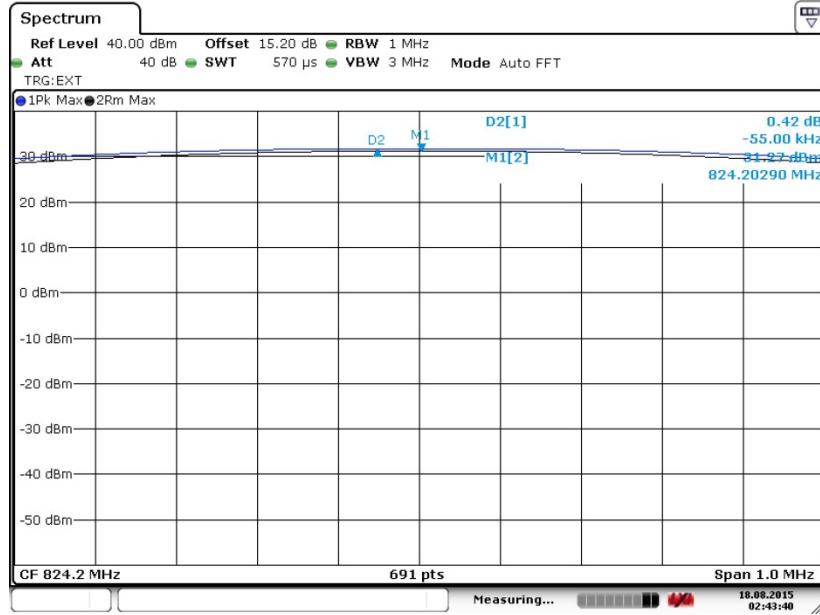

Date: 18.AUG.2015 02:43:40

Peak-to-Average Ratio on Channel 189 (836.4 MHz)

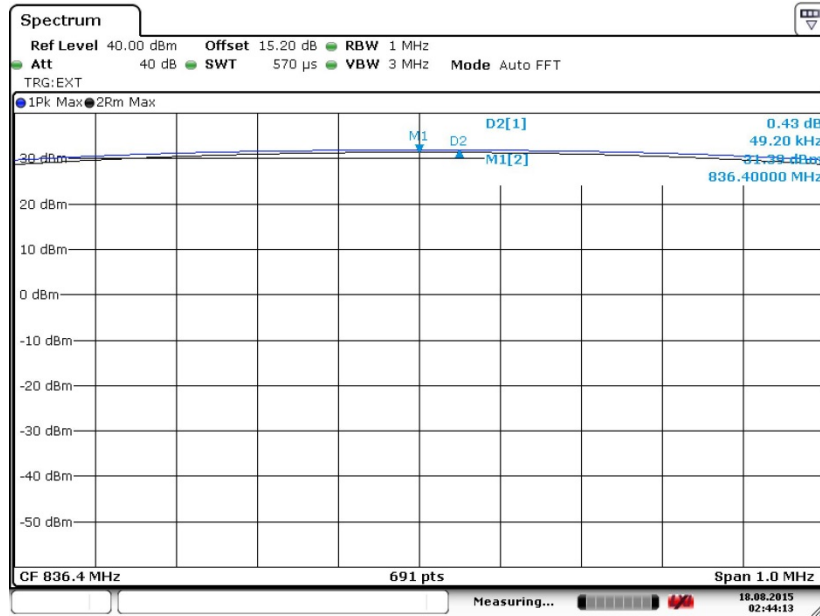

Date: 18.AUG.2015 02:44:13



Peak-to-Average Ratio on Channel 251 (848.8 MHz)

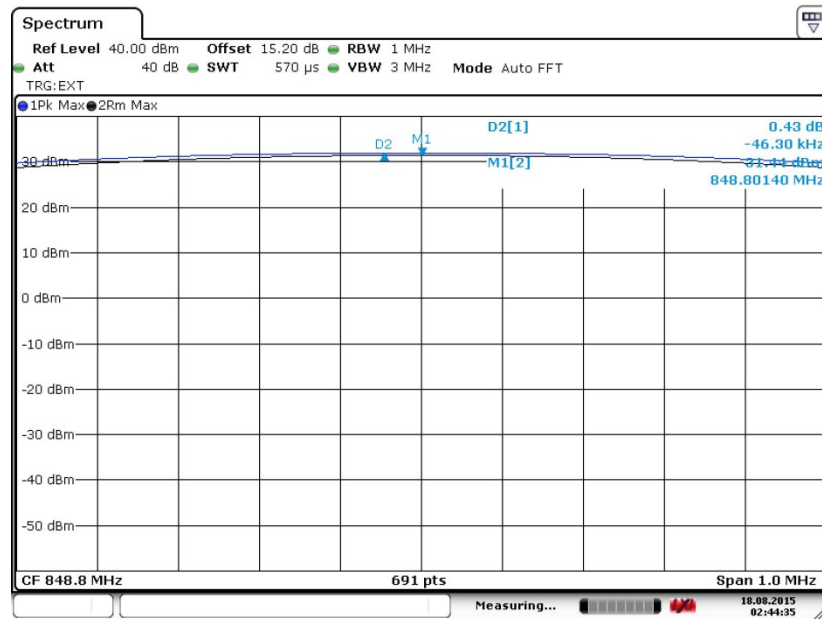

Date: 18.AUG.2015 02:44:35



Band :	GSM 850	Test Mode :	EDGE class 8 Link (8PSK)
---------------	---------	--------------------	--------------------------

Peak-to-Average Ratio on Channel 128 (824.2 MHz)

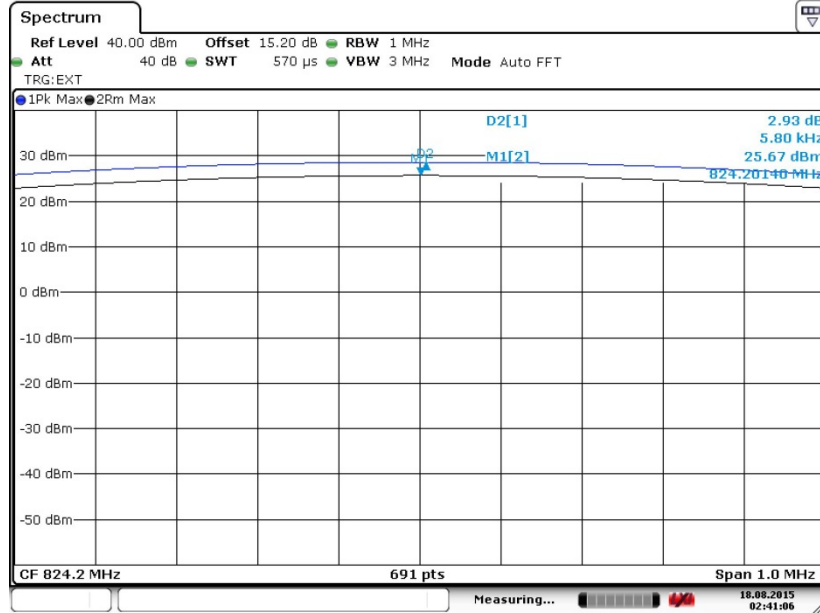

Date: 18.AUG.2015 02:41:06

Peak-to-Average Ratio on Channel 189 (836.4 MHz)

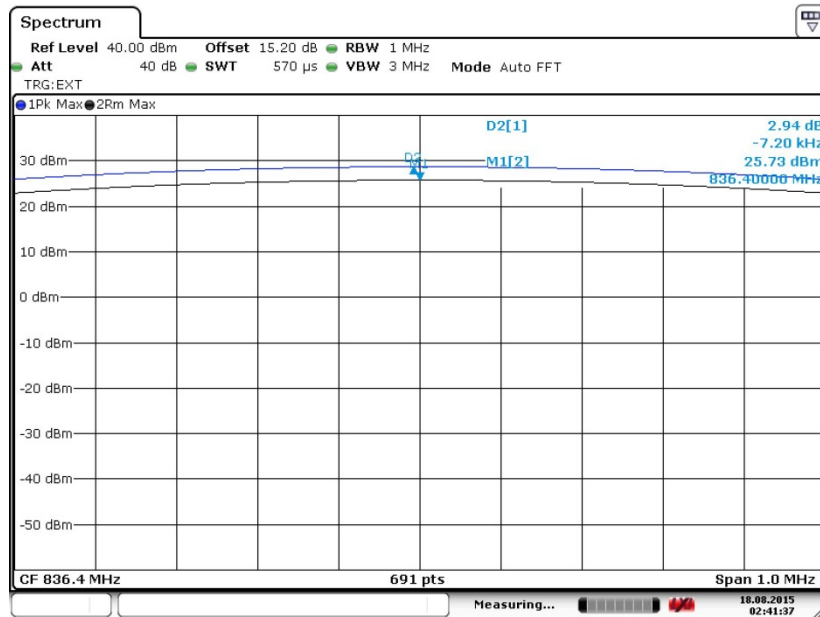

Date: 18.AUG.2015 02:41:37



Peak-to-Average Ratio on Channel 251 (848.8 MHz)

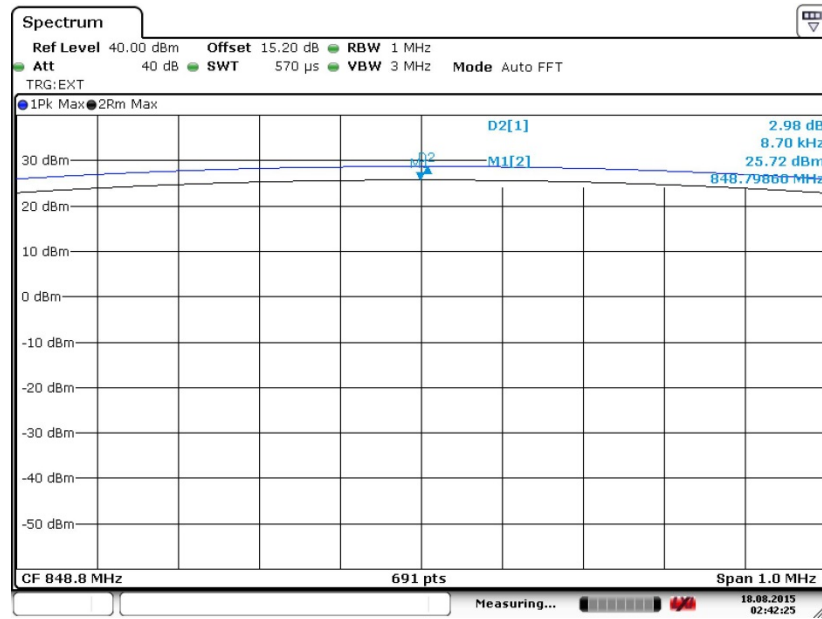

Date: 18.AUG.2015 02:42:25



Band :	GSM 1900	Test Mode :	GSM Link (GMSK)
--------	----------	-------------	-----------------

Peak-to-Average Ratio on Channel 512 (1850.2 MHz)

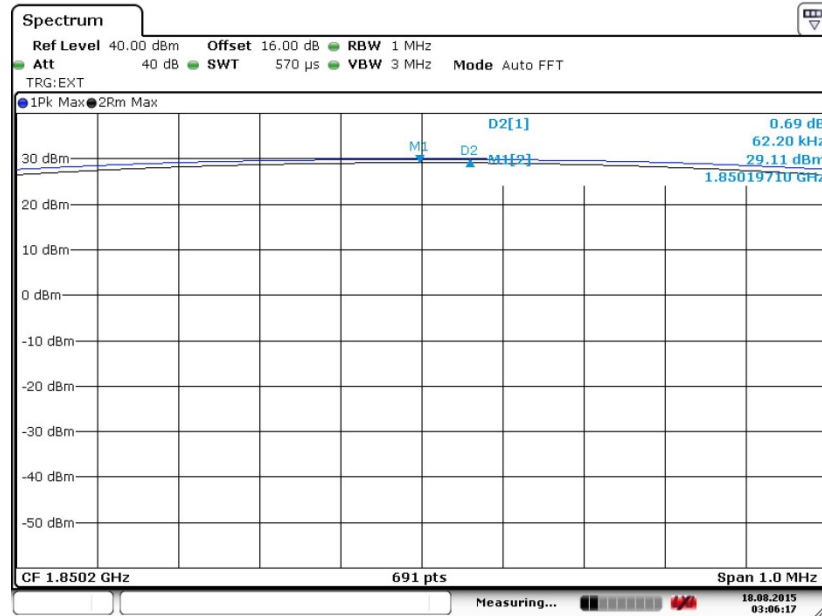

Date: 18.AUG.2015 03:06:17

Peak-to-Average Ratio on Channel 661 (1880.0 MHz)

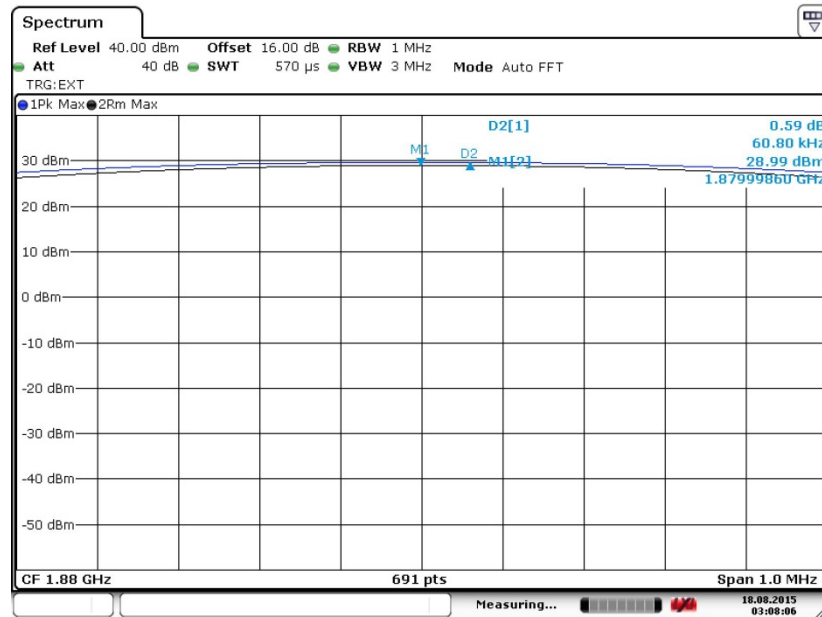

Date: 18.AUG.2015 03:06:06



Peak-to-Average Ratio on Channel 810 (1909.8 MHz)

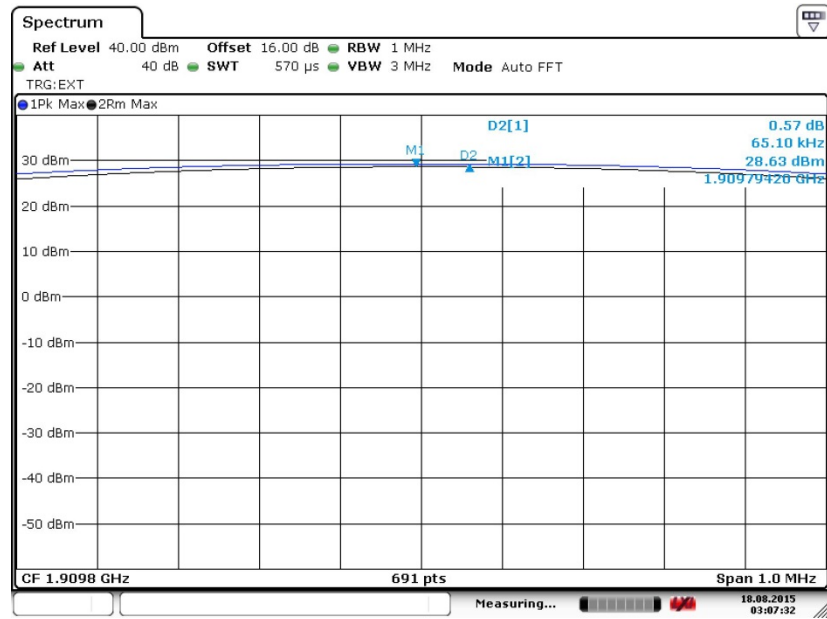

Date: 18.AUG.2015 03:07:32



Band :	GSM 1900	Test Mode :	EDGE class 8 Link (8PSK)
---------------	----------	--------------------	--------------------------

Peak-to-Average Ratio on Channel 512 (1850.2 MHz)

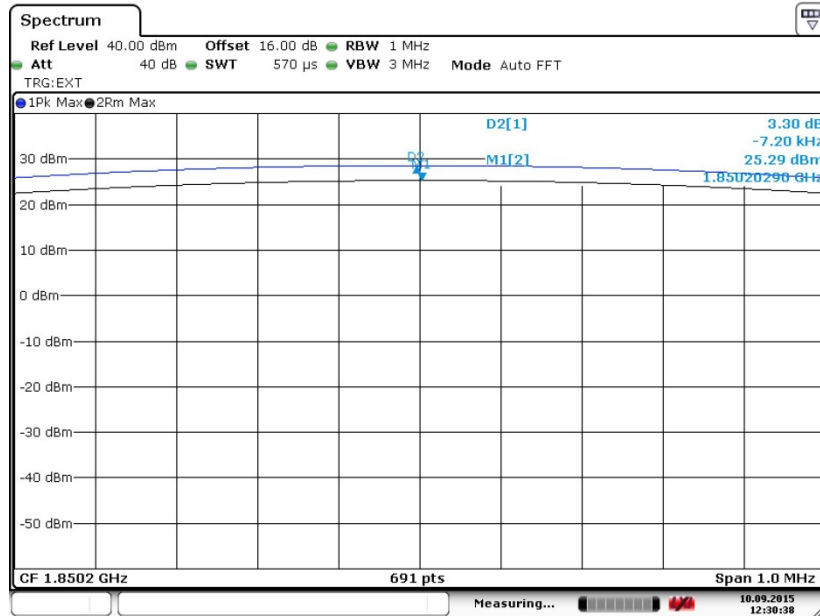

Date: 10.SEP.2015 12:30:38

Peak-to-Average Ratio on Channel 661 (1880.0 MHz)

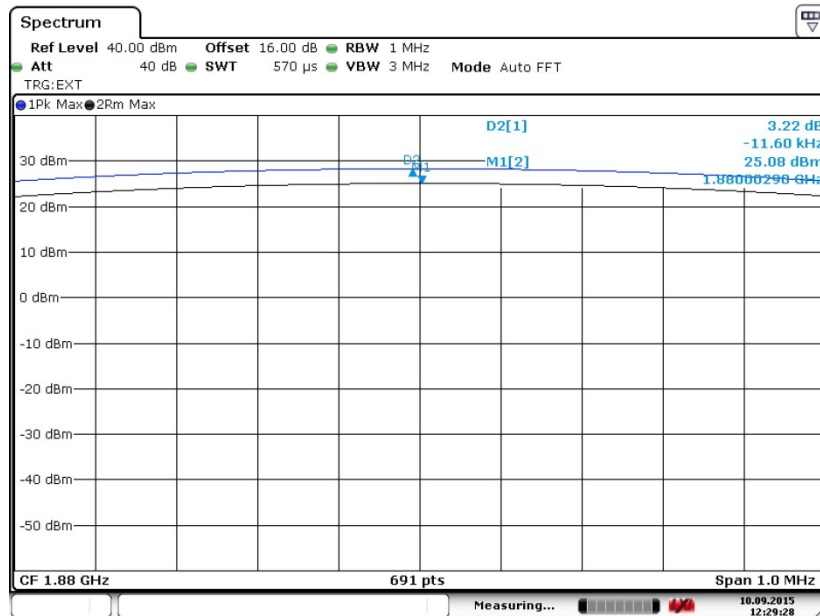

Date: 10.SEP.2015 12:29:28



Peak-to-Average Ratio on Channel 810 (1909.8 MHz)

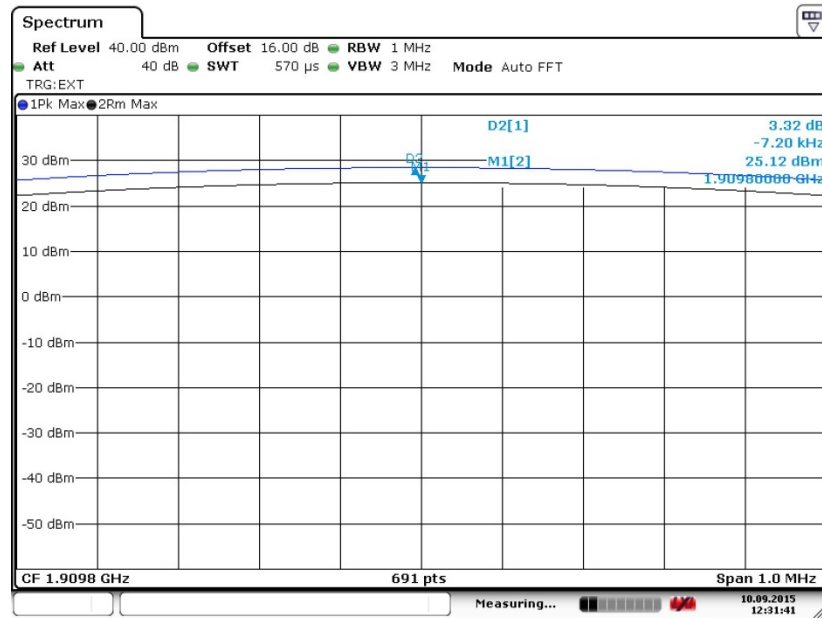

Date: 10.SEP.2015 12:31:41



Band :	WCDMA Band V	Test Mode :	RMC 12.2Kbps Link (QPSK)
---------------	--------------	--------------------	--------------------------

Peak-to-Average Ratio on Channel 4132 (826.4 MHz)

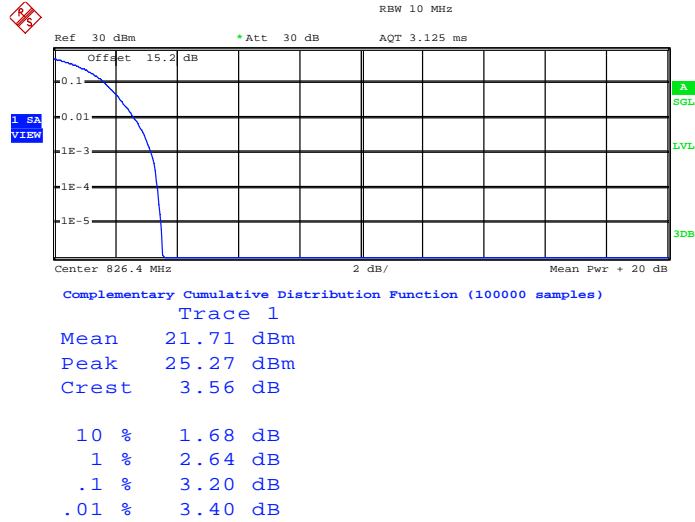

Date: 30.SEP.2015 16:14:33

Peak-to-Average Ratio on Channel 4182 (836.4 MHz)

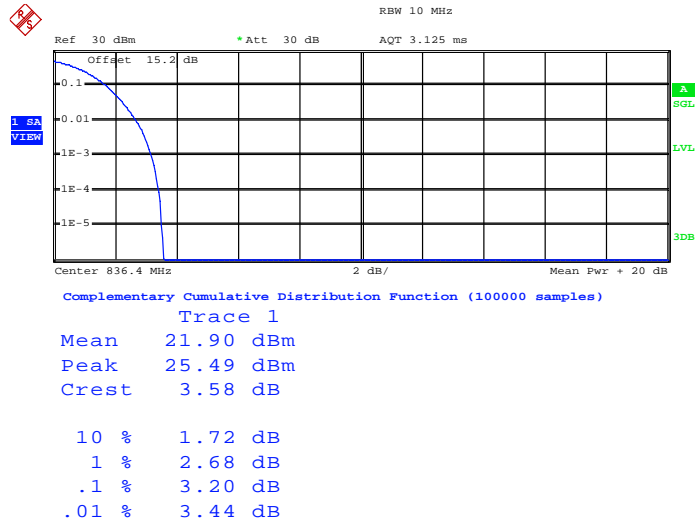

Date: 30.SEP.2015 16:15:10



Peak-to-Average Ratio on Channel 4233 (846.6 MHz)

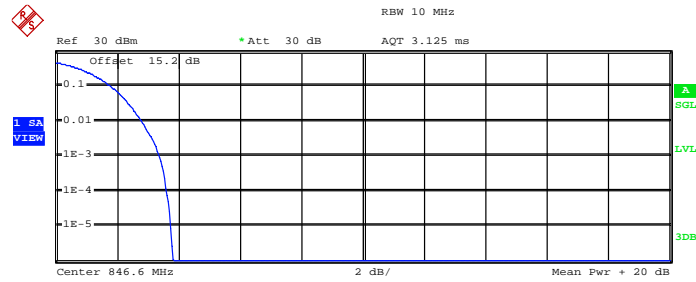

Complementary Cumulative Distribution Function (100000 samples)

Trace 1

Mean	22.03 dBm
Peak	25.84 dBm
Crest	3.81 dB
10 %	1.80 dB
1 %	2.80 dB
.1 %	3.40 dB
.01 %	3.60 dB

Date: 30.SEP.2015 16:13:50



Band :	WCDMA Band IV	Test Mode :	RMC 12.2Kbps Link (QPSK)
---------------	---------------	--------------------	--------------------------

Peak-to-Average Ratio on Channel 1312 (1712.4 MHz)

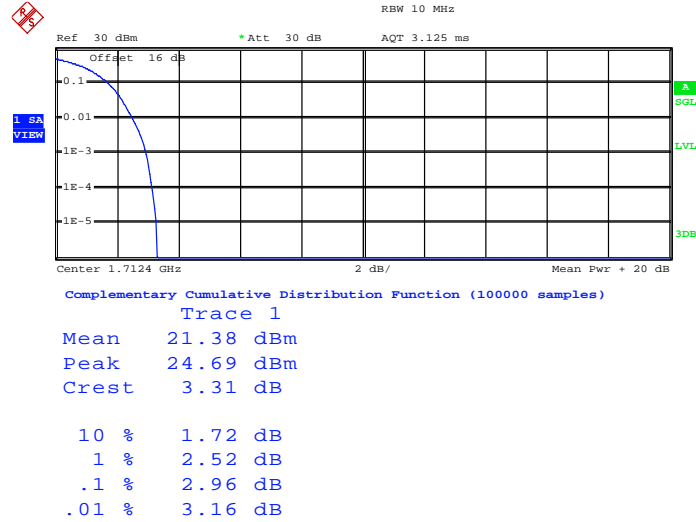

Date: 29.AUG.2015 07:53:48

Peak-to-Average Ratio on Channel 1413 (1732.6 MHz)

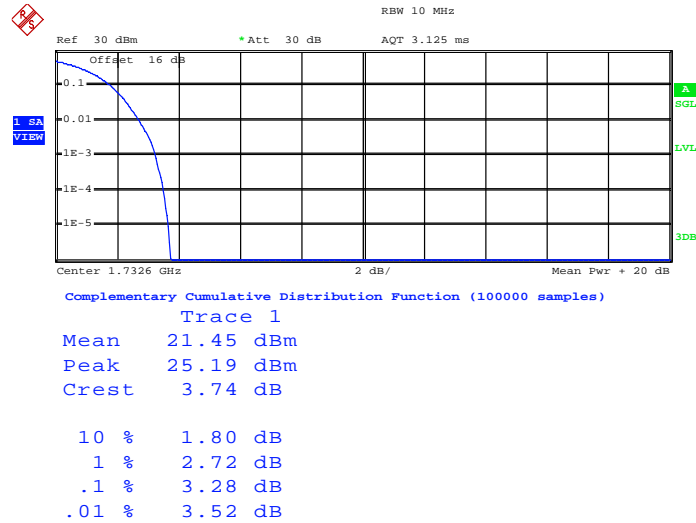

Date: 29.AUG.2015 07:53:25



Peak-to-Average Ratio on Channel 1513 (1752.6 MHz)

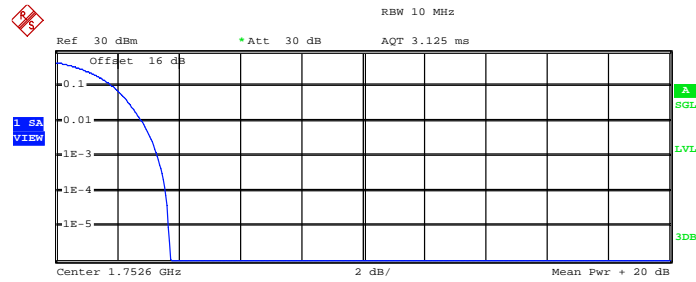

Complementary Cumulative Distribution Function (100000 samples)

Trace 1

Mean	21.52 dBm
Peak	25.26 dBm
Crest	3.74 dB
10 %	1.88 dB
1 %	2.80 dB
.1 %	3.32 dB
.01 %	3.60 dB

Date: 29.AUG.2015 07:53:01



Band :	WCDMA Band II	Test Mode :	RMC 12.2Kbps Link (QPSK)
---------------	---------------	--------------------	--------------------------

Peak-to-Average Ratio on Channel 9262 (1852.4 MHz)

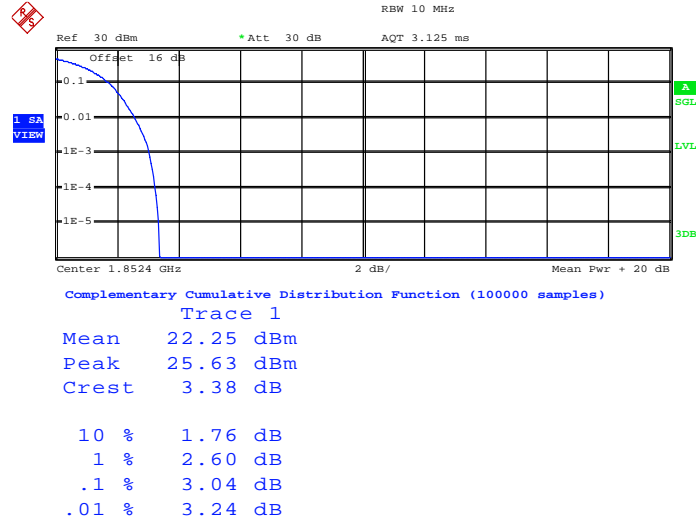

Date: 18.AUG.2015 03:44:29

Peak-to-Average Ratio on Channel 9400 (1880.0 MHz)

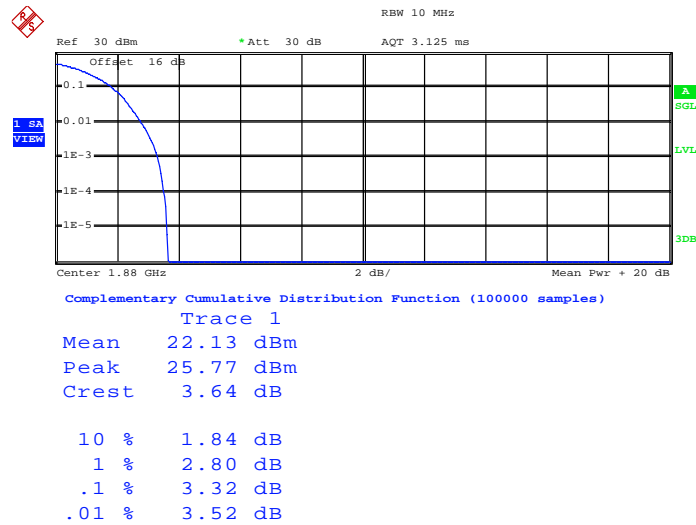

Date: 18.AUG.2015 03:44:09



Peak-to-Average Ratio on Channel 9538 (1907.6 MHz)

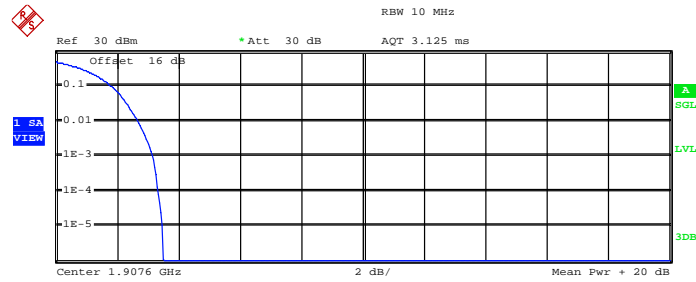

Complementary Cumulative Distribution Function (100000 samples)

Trace 1

Mean	22.12 dBm
Peak	25.63 dBm
Crest	3.51 dB
10 %	1.84 dB
1 %	2.68 dB
.1 %	3.16 dB
.01 %	3.36 dB

Date: 18.AUG.2015 03:43:48



3.3 Effective Radiated Power and Effective Isotropic Radiated Power Measurement

3.3.1 Description of the ERP/EIRP Measurement

The substitution method, in ANSI / TIA / EIA-603-C-2004, was used for ERP/EIRP measurement, and the spectrum analyzer configuration follows KDB 971168 D01 Power Meas. License Digital Systems v02r02. The ERP of mobile transmitters must not exceed 7 Watts (Cellular Band) and the EIRP of mobile transmitters are limited to 2 Watts (PCS Band) and 1 Watts (AWS Band).

3.3.2 Measuring Instruments

The measuring equipment is listed in the section 4 of this test report.

3.3.3 Test Procedures

1. The testing follows FCC KDB 971168 v02r02 Section 5.2.1. (for CDMA/WCDMA), Section 5.2.2.2 (for GSM/GPRS/EDGE) and ANSI / TIA-603-C-2004 Section 2.2.17.
2. The EUT was placed on a non-conductive rotating platform 0.8 meters high in a semi-anechoic chamber. The radiated emission at the fundamental frequency was measured at 3 m with a test antenna and a spectrum analyzer with RMS detector per section 5. of KDB 971168 D01.
3. During the measurement, the system simulator parameters were set to force the EUT transmitting at maximum output power. The maximum emission was recorded from analyzer power level (LVL) from the 360 degrees rotation of the turntable and the test antenna raised and lowered over a range from 1 to 4 meters in both horizontally and vertically polarized orientations.
4. Effective Isotropic Radiated Power (EIRP) was measured by substitution method according to TIA/EIA-603-C. The EUT was replaced by the substitution antenna at same location, and then a known power from S.G. was applied into the dipole antenna through a Tx cable, and then recorded the maximum Analyzer reading through raised and lowered the test antenna. The correction factor (in dB) = S.G. - Tx Cable loss + Substitution antenna gain - Analyzer reading. Then the EUT's EIRP was calculated with the correction factor, $EIRP = LVL + \text{Correction factor}$ and $ERP = EIRP - 2.15$. Take the record of the output power at substitution antenna.



	GSM/GPRS/EDGE	WCDMA/HSPA
SPAN	500kHz	10MHz
RBW	10kHz	100kHz
VBW	30kHz	300kHz
Detector	RMS	RMS
Trace	Average	Average
Average Type	Power	Power
Sweep Count	100	100

3.3.4 Test Result of ERP

GSM850 (GSM) Radiated Power ERP					
Channel	Frequency (MHz)	Horizontal		Vertical	
		ERP(dBm)	ERP(W)	ERP(dBm)	ERP(W)
Lowest	824.2	30.13	1.0304	8.49	0.0071
Middle	836.4	29.92	0.9817	8.19	0.0066
Highest	848.8	29.61	0.9141	8.16	0.0065
Limit	ERP < 7W	Result		PASS	

GSM850 (EDGE class 8) Radiated Power ERP					
Channel	Frequency (MHz)	Horizontal		Vertical	
		ERP(dBm)	ERP(W)	ERP(dBm)	ERP(W)
Lowest	824.2	24.75	0.2985	1.79	0.0015
Middle	836.4	24.35	0.2723	1.93	0.0016
Highest	848.8	23.78	0.2388	2.10	0.0016
Limit	ERP < 7W	Result		PASS	

WCDMA Band V (RMC 12.2Kbps) Radiated Power ERP					
Channel	Frequency (MHz)	Horizontal		Vertical	
		ERP(dBm)	ERP(W)	ERP(dBm)	ERP(W)
Lowest	826.4	18.57	0.0719	-0.47	0.0009
Middle	836.4	18.93	0.0782	0.33	0.0011
Highest	846.6	18.97	0.0789	0.95	0.0012
Limit	ERP < 7W	Result		PASS	



3.3.5 Test Result of EIRP

GSM1900 (GSM) Radiated Power EIRP					
Channel	Frequency (MHz)	Horizontal		Vertical	
		EIRP(dBm)	EIRP(W)	EIRP(dBm)	EIRP(W)
Lowest	1850.2	32.09	1.6181	29.95	0.9886
Middle	1880	31.61	1.4488	30.10	1.0233
Highest	1909.8	31.06	1.2764	29.83	0.9616
Limit	EIRP < 2W	Result		PASS	

GSM1900 (EDGE class 8) Radiated Power EIRP					
Channel	Frequency (MHz)	Horizontal		Vertical	
		EIRP(dBm)	EIRP(W)	EIRP(dBm)	EIRP(W)
Lowest	1850.2	28.61	0.7261	26.71	0.4688
Middle	1880	28.15	0.6531	27.18	0.5224
Highest	1909.8	27.57	0.5715	26.83	0.4819
Limit	EIRP < 2W	Result		PASS	

WCDMA Band II (RMC 12.2Kbps) Radiated Power EIRP					
Channel	Frequency (MHz)	Horizontal		Vertical	
		EIRP(dBm)	EIRP(W)	EIRP(dBm)	EIRP(W)
Lowest	1852.4	24.76	0.2992	22.86	0.1932
Middle	1880	24.76	0.2992	23.28	0.2128
Highest	1907.6	24.73	0.2972	23.47	0.2223
Limit	EIRP < 2W	Result		PASS	

WCDMA Band IV(RMC 12.2Kbps) Radiated Power EIRP					
Channel	Frequency (MHz)	Horizontal		Vertical	
		EIRP(dBm)	EIRP(W)	EIRP(dBm)	EIRP(W)
Lowest	1712.4	24.56	0.2858	22.67	0.1849
Middle	1732.6	25.22	0.3327	23.50	0.2239
Highest	1752.6	25.34	0.3420	23.66	0.2323
Limit	EIRP < 1W	Result		PASS	

3.4 99% Occupied Bandwidth and 26dB Bandwidth Measurement

3.4.1 Description of 99% Occupied Bandwidth and 26dB Bandwidth Measurement

The 99% occupied bandwidth is the width of a frequency band such that, below the lower and above the upper frequency limits, the mean powers emitted are each equal to a specified percentage 0.5% of the total mean transmitted power.

The emission bandwidth is defined as the width of the signal between two points, located at the 2 sides of the carrier frequency, outside of which all emissions are attenuated at least 26 dB below the transmitter power.

3.4.2 Measuring Instruments

The measuring equipment is listed in the section 4 of this test report.

3.4.3 Test Procedures

5. The testing follows FCC KDB 971168 v02r02 Section 4.2.
6. The EUT was connected to the spectrum analyzer and system simulator via a power divider.
7. The RF output of the EUT was connected to the spectrum analyzer by RF cable and attenuator. The path loss was compensated to the results for each measurement.
8. The 99% occupied bandwidth were measured, set RBW= 1% of span, VBW= 3*RBW, sample detector, trace maximum hold.
9. The 26dB bandwidth were measured, set RBW= 1% of EBW, VBW= 3*RBW, peak detector, trace maximum hold.

3.4.4 Test Setup

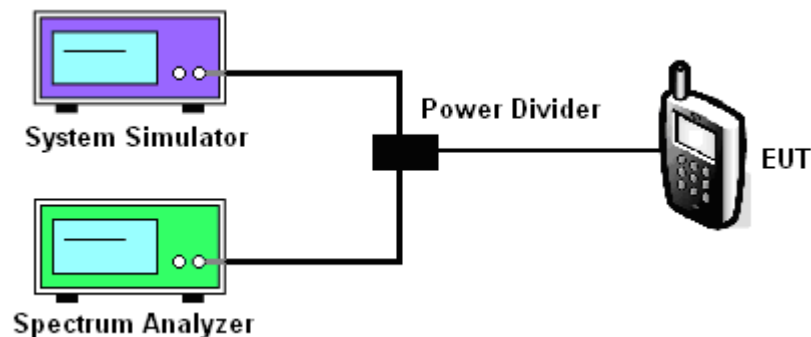



3.4.5 Test Result of Occupied Bandwidth and 26dB Bandwidth

Cellular Band						
Modes	GSM850 (GSM)			GSM850 (EDGE class 8)		
Channel	128 (Low)	189 (Mid)	251 (High)	128 (Low)	189 (Mid)	251 (High)
Frequency (MHz)	824.2	836.4	848.8	824.2	836.4	848.8
99% OBW (kHz)	246.00	244.00	244.00	246.00	244.00	244.00
26dB BW (kHz)	314.00	316.00	318.00	310.00	314.00	308.00

PCS Band						
Modes	GSM1900 (GSM)			GSM1900 (EDGE class 8)		
Channel	512 (Low)	661 (Mid)	810 (High)	512 (Low)	661 (Mid)	810 (High)
Frequency (MHz)	1850.2	1880	1909.8	1850.2	1880	1909.8
99% OBW (kHz)	248.00	248.00	244.00	248.00	248.00	248.00
26dB BW (kHz)	316.00	312.00	312.00	310.00	308.00	314.00

Cellular Band			
Modes	WCDMA Band V (RMC 12.2Kbps)		
Channel	4132 (Low)	4182 (Mid)	4233 (High)
Frequency (MHz)	826.4	836.4	846.6
99% OBW (MHz)	4.14	4.14	4.16
26dB BW (MHz)	4.74	4.72	4.72

AWS Band			
Modes	WCDMA Band IV (RMC 12.2Kbps)		
Channel	1312(Low)	1413 (Mid)	1513 (High)
Frequency (MHz)	1712.4	1732.6	1752.6
99% OBW (MHz)	4.16	4.16	4.16
26dB BW (MHz)	4.72	4.72	4.72



PCS Band			
Modes	WCDMA Band II (RMC 12.2Kbps)		
Channel	9262 (Low)	9400 (Mid)	9538 (High)
Frequency (MHz)	1852.4	1880	1907.6
99% OBW (MHz)	4.16	4.16	4.16
26dB BW (MHz)	4.76	4.72	4.72



3.4.6 Test Result (Plots) of Occupied Bandwidth and 26dB Bandwidth

Band :	GSM 850	Test Mode :	GSM Link (GMSK)
--------	---------	-------------	-----------------

99% Occupied Bandwidth Plot on Channel 128 (824.2 MHz)

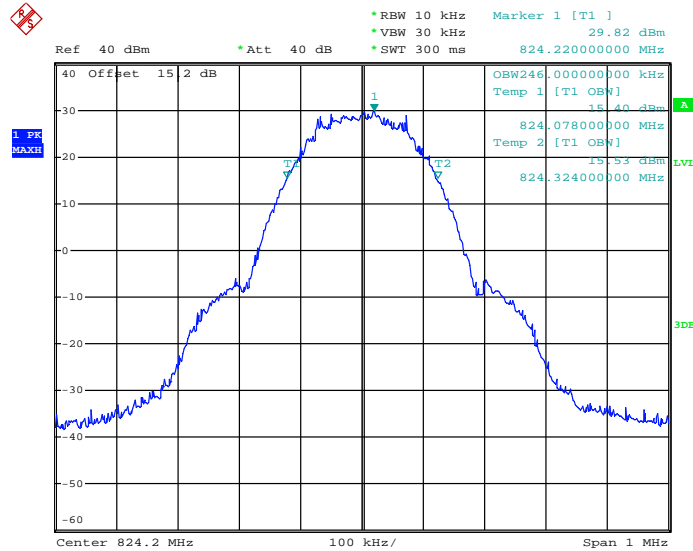

Date: 17.AUG.2015 22:21:48

26dB Bandwidth Plot on Channel 128 (824.2 MHz)

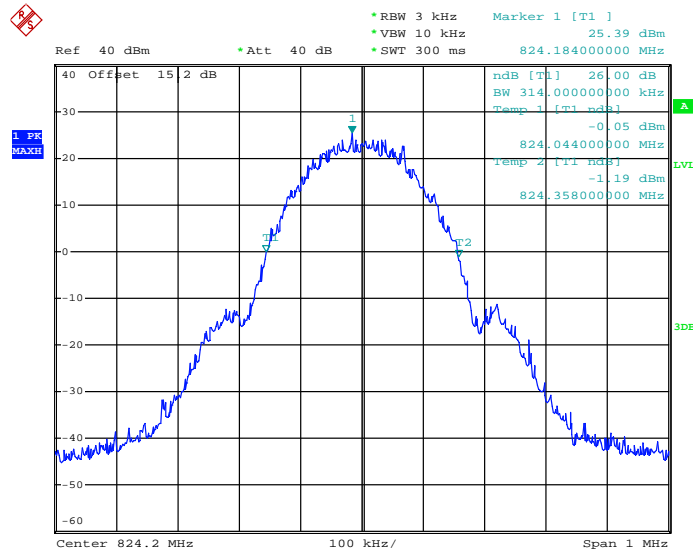

Date: 17.AUG.2015 21:53:30



99% Occupied Bandwidth Plot on Channel 189 (836.4 MHz)

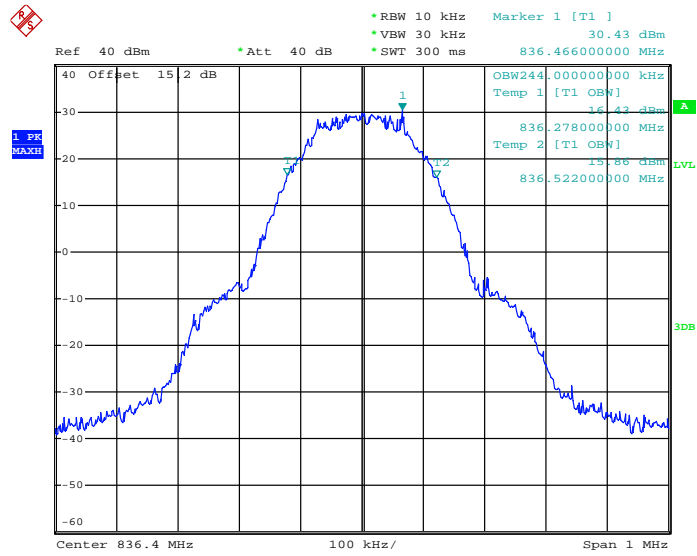

Date: 17.AUG.2015 22:12:42

26dB Bandwidth Plot on Channel 189 (836.4 MHz)

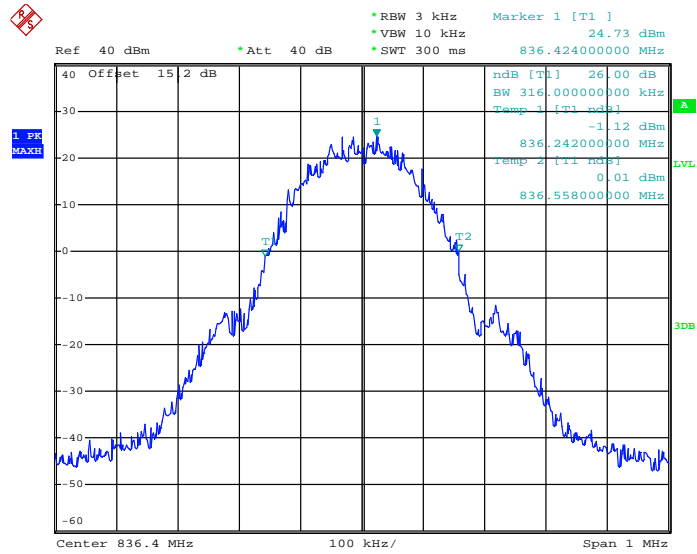

Date: 17.AUG.2015 22:24:34



99% Occupied Bandwidth Plot on Channel 251 (848.8 MHz)

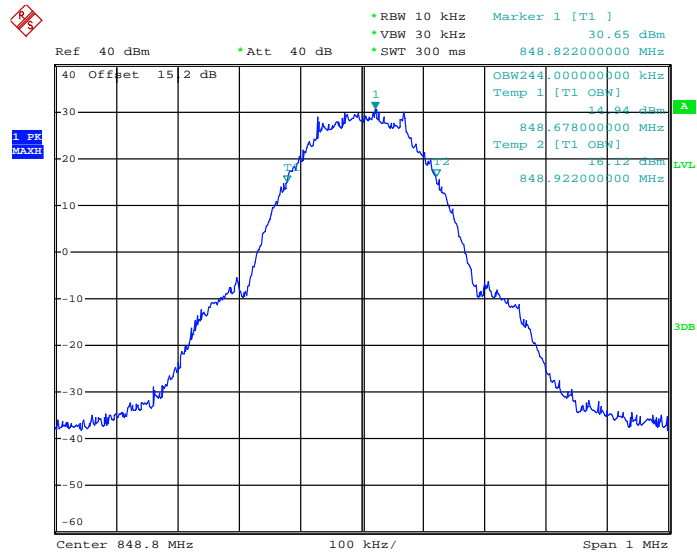

Date: 17.AUG.2015 21:57:08

26dB Bandwidth Plot on Channel 251 (848.8 MHz)

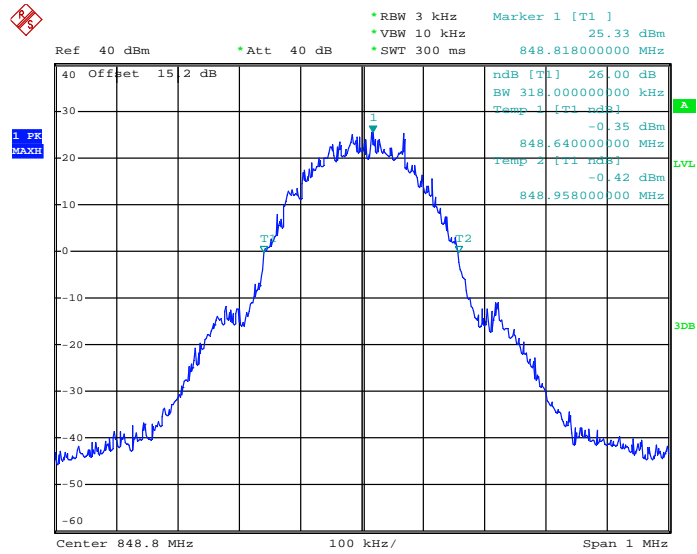

Date: 17.AUG.2015 21:55:31



Band :	GSM 850	Test Mode :	EDGE class 8 Link (8PSK)
---------------	---------	--------------------	--------------------------

99% Occupied Bandwidth Plot on Channel 128 (824.2 MHz)

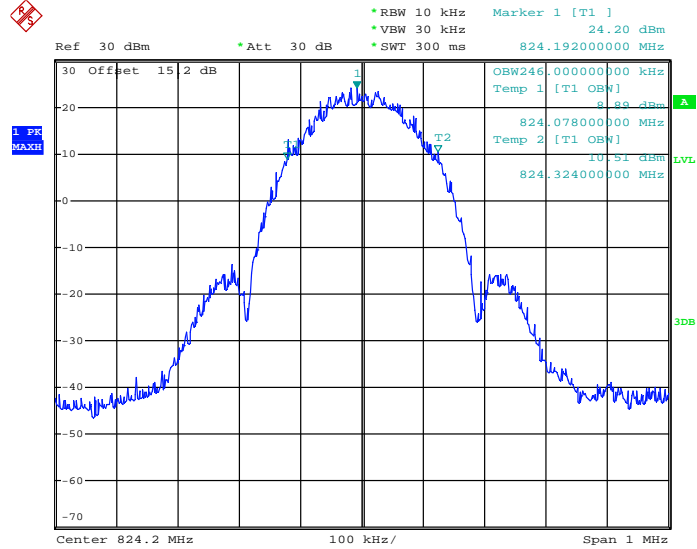

Date: 17.AUG.2015 23:27:37

26dB Bandwidth Plot on Channel 128 (824.2 MHz)

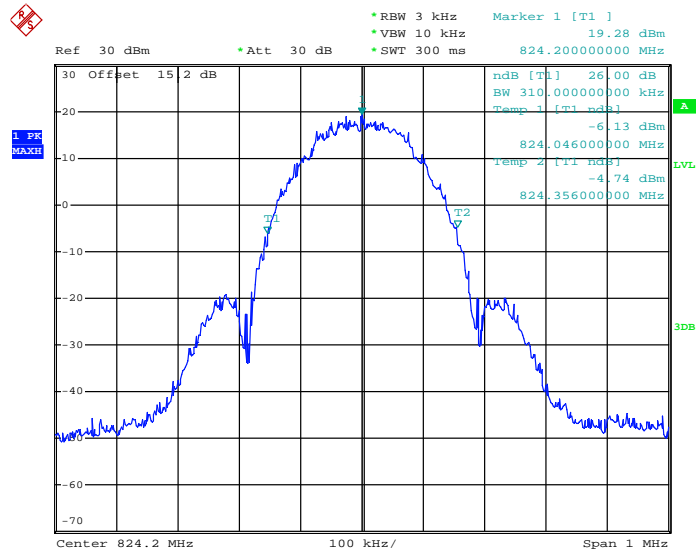

Date: 17.AUG.2015 22:52:32



99% Occupied Bandwidth Plot on Channel 189 (836.4 MHz)

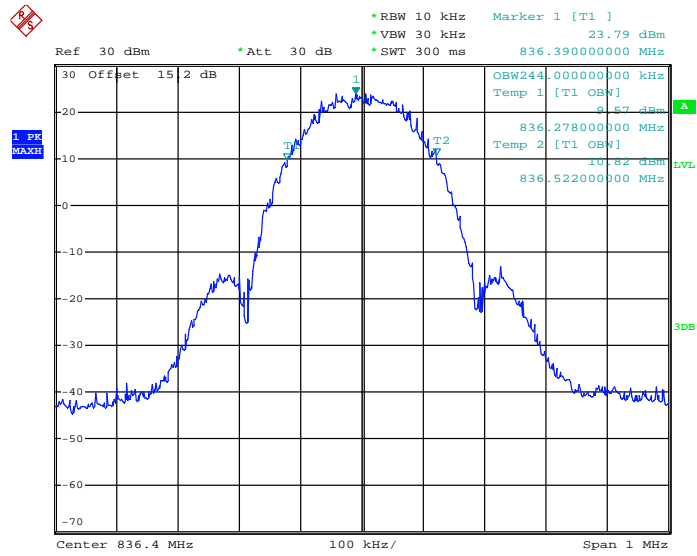

Date: 17.AUG.2015 23:25:30

26dB Bandwidth Plot on Channel 189 (836.4 MHz)

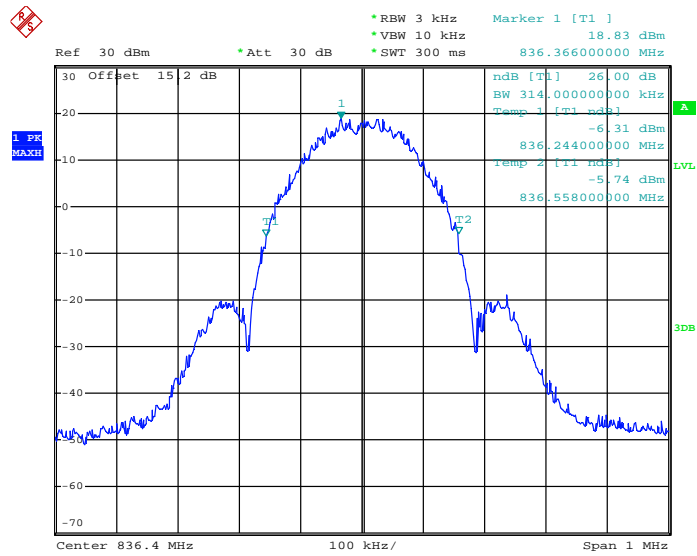

Date: 17.AUG.2015 22:55:25



99% Occupied Bandwidth Plot on Channel 251 (848.8 MHz)

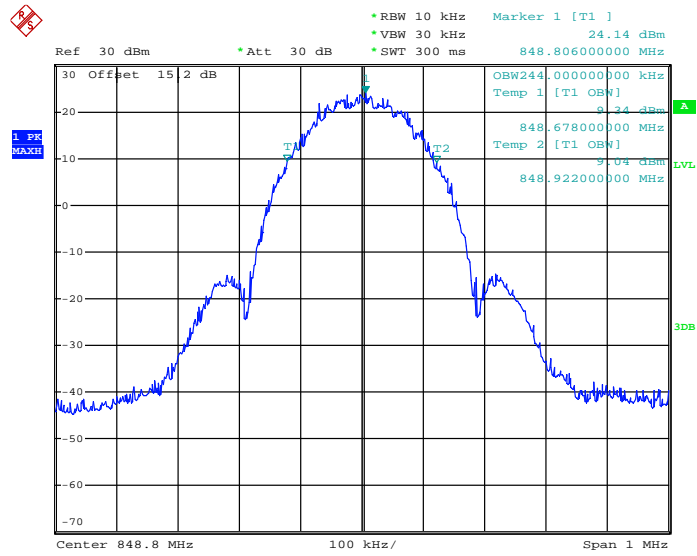

Date: 17.AUG.2015 23:01:40

26dB Bandwidth Plot on Channel 251 (848.8 MHz)

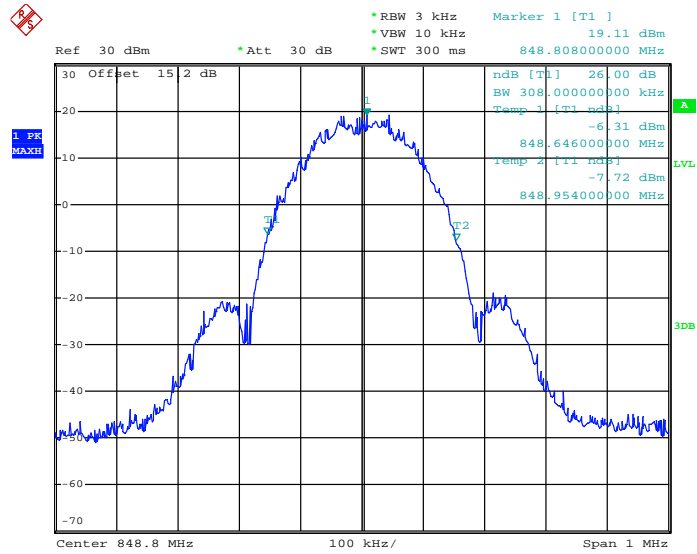

Date: 17.AUG.2015 22:58:34



Band :	GSM 1900	Test Mode :	GSM Link (GMSK)
--------	----------	-------------	-----------------

99% Occupied Bandwidth Plot on Channel 512 (1850.2 MHz)

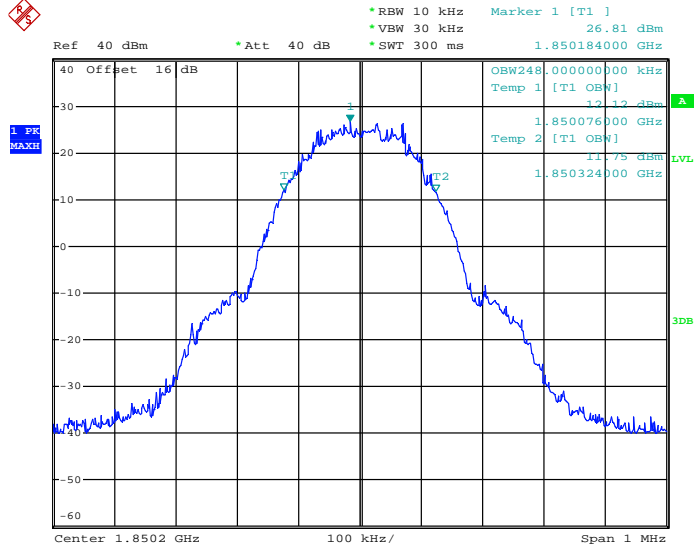

Date: 18.AUG.2015 04:23:42

26dB Bandwidth Plot on Channel 512 (1850.2 MHz)

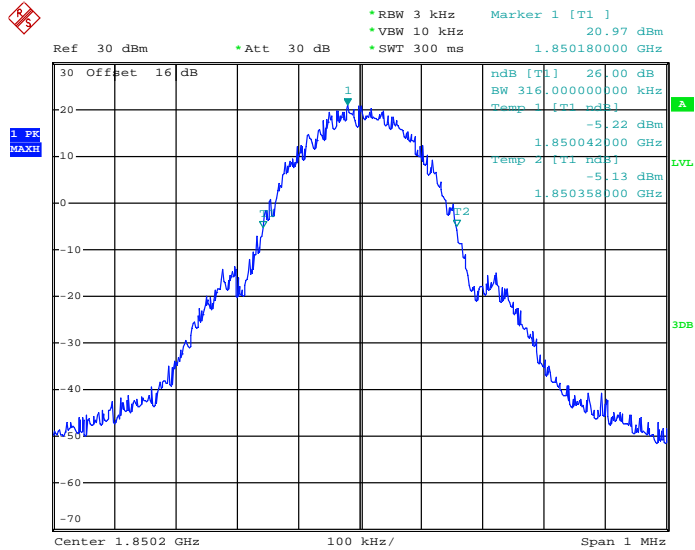

Date: 18.AUG.2015 04:20:11



99% Occupied Bandwidth Plot on Channel 661 (1880.0 MHz)

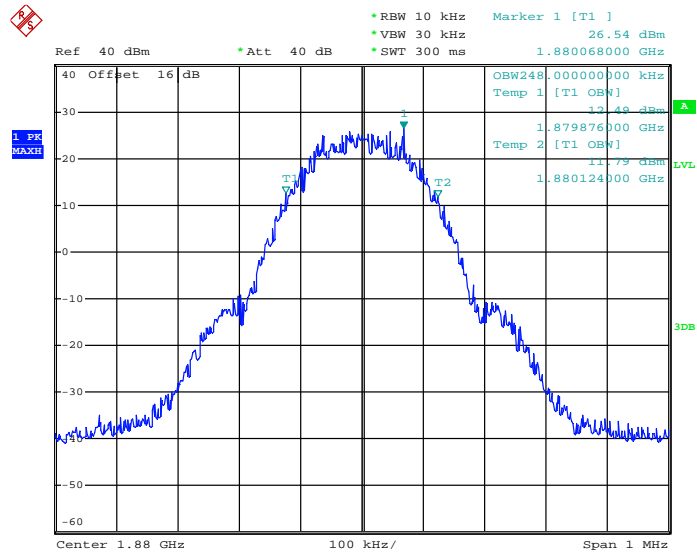

Date: 18.AUG.2015 04:35:56

26dB Bandwidth Plot on Channel 661 (1880.0 MHz)

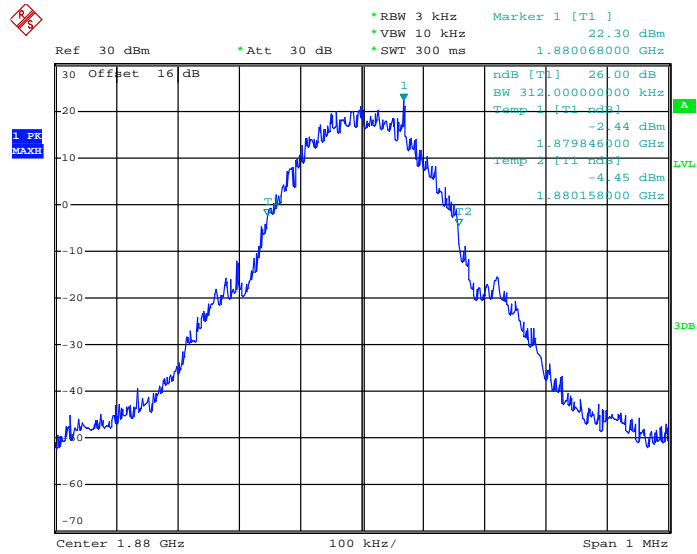

Date: 18.AUG.2015 04:20:41



99% Occupied Bandwidth Plot on Channel 810 (1909.8 MHz)

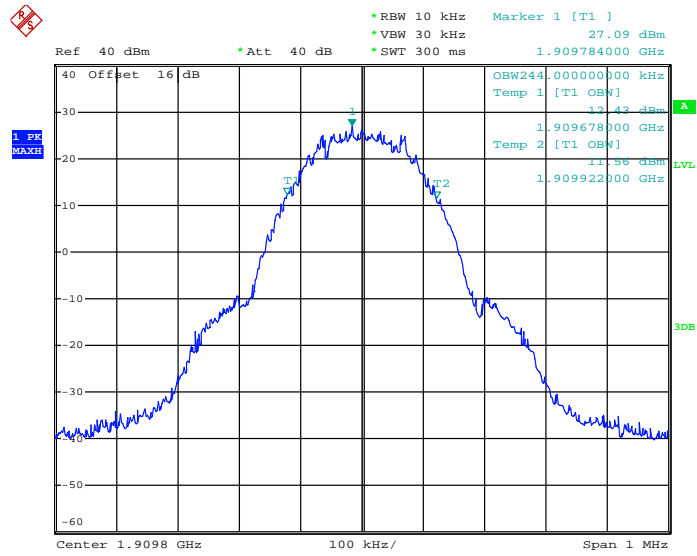

Date: 18.AUG.2015 04:24:42

26dB Bandwidth Plot on Channel 810 (1909.8 MHz)

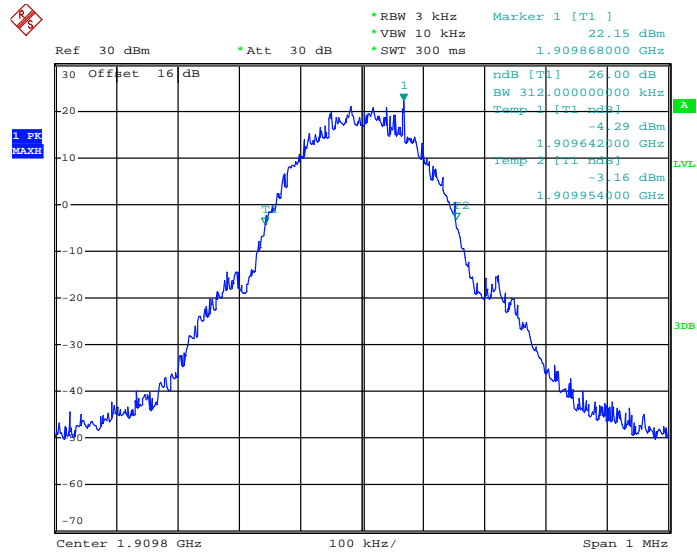

Date: 18.AUG.2015 04:21:48



Band :	GSM 1900	Test Mode :	EDGE class 8 Link (8PSK)
---------------	----------	--------------------	--------------------------

99% Occupied Bandwidth Plot on Channel 512 (1850.2 MHz)

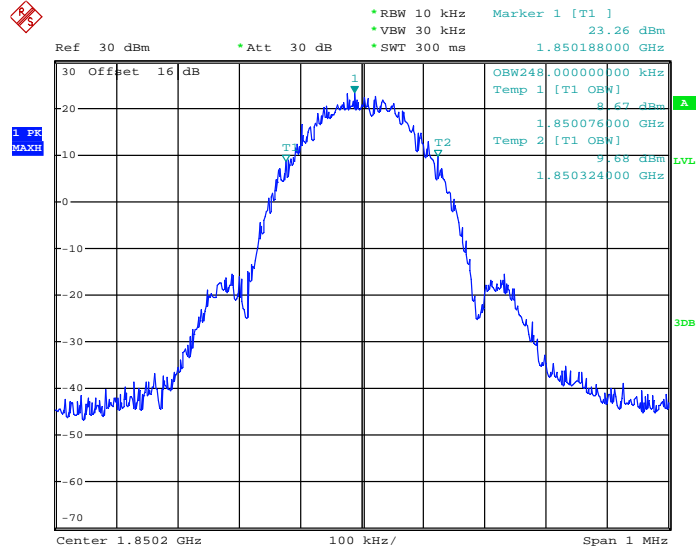

Date: 9.SEP.2015 21:32:27

26dB Bandwidth Plot on Channel 512 (1850.2 MHz)

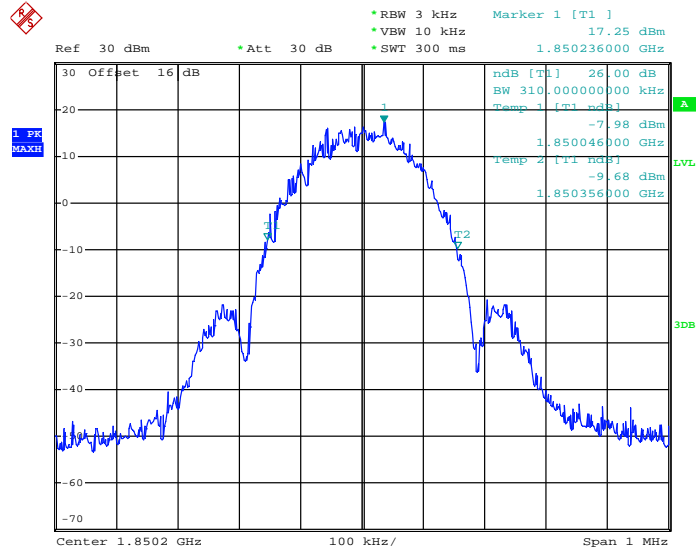

Date: 9.SEP.2015 21:30:22



99% Occupied Bandwidth Plot on Channel 661 (1880.0 MHz)

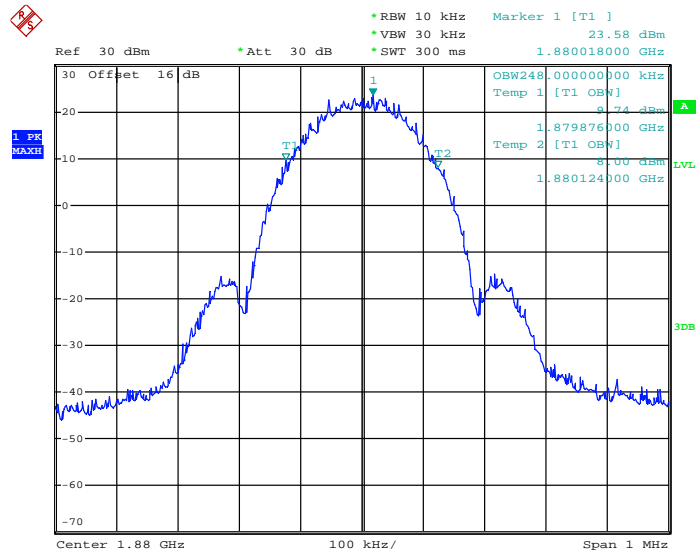

Date: 9.SEP.2015 21:33:16

26dB Bandwidth Plot on Channel 661 (1880.0 MHz)

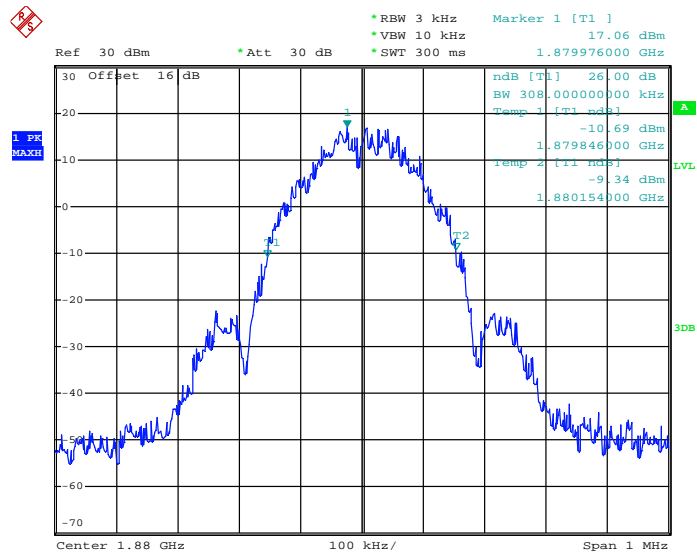

Date: 9.SEP.2015 21:47:27



99% Occupied Bandwidth Plot on Channel 810 (1909.8 MHz)

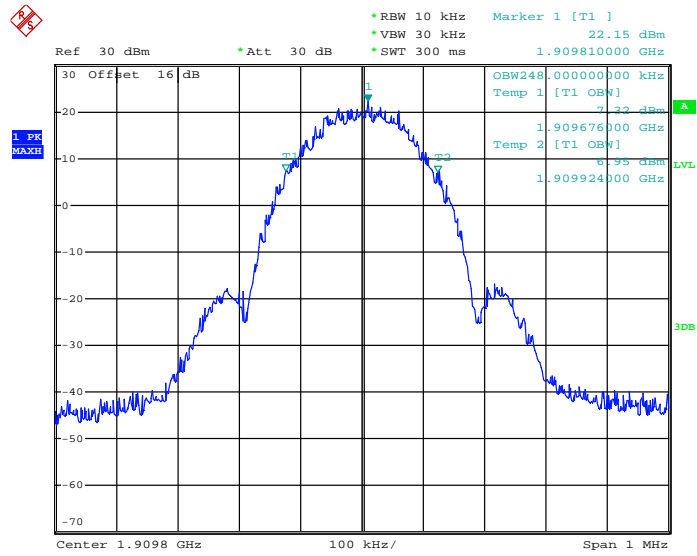

Date: 9.SEP.2015 22:06:57

26dB Bandwidth Plot on Channel 810 (1909.8 MHz)

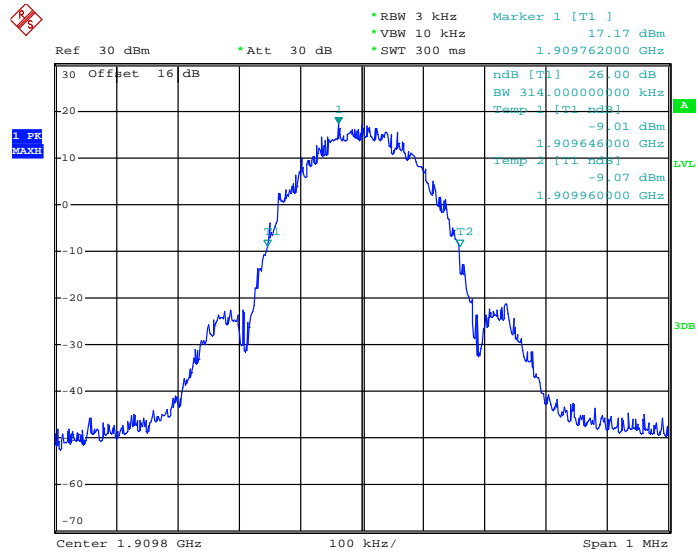

Date: 9.SEP.2015 21:31:10



Band :	WCDMA Band V	Test Mode :	RMC 12.2Kbps Link (QPSK)
---------------	--------------	--------------------	--------------------------

99% Occupied Bandwidth Plot on Channel 4132 (826.4 MHz)

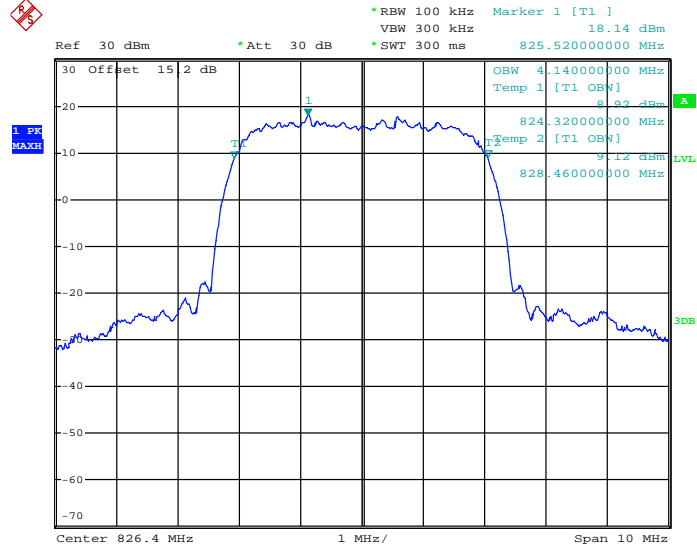

Date: 30.SEP.2015 16:38:44

26dB Bandwidth Plot on Channel 4132 (826.4 MHz)

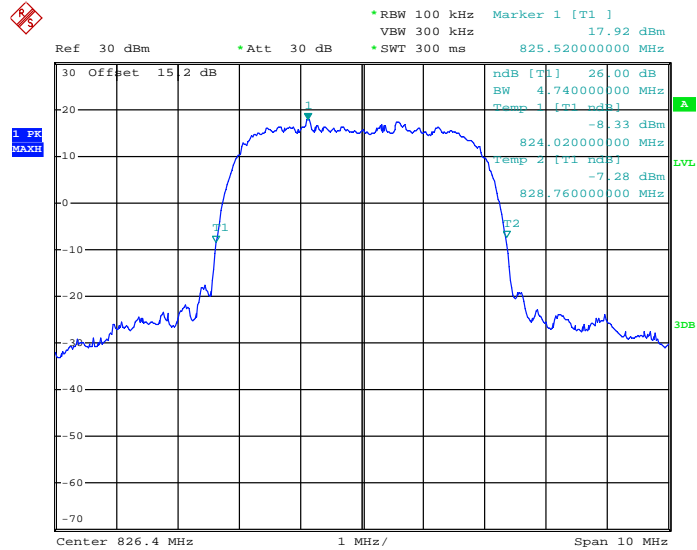

Date: 30.SEP.2015 16:31:43



99% Occupied Bandwidth Plot on Channel 4182 (836.4 MHz)

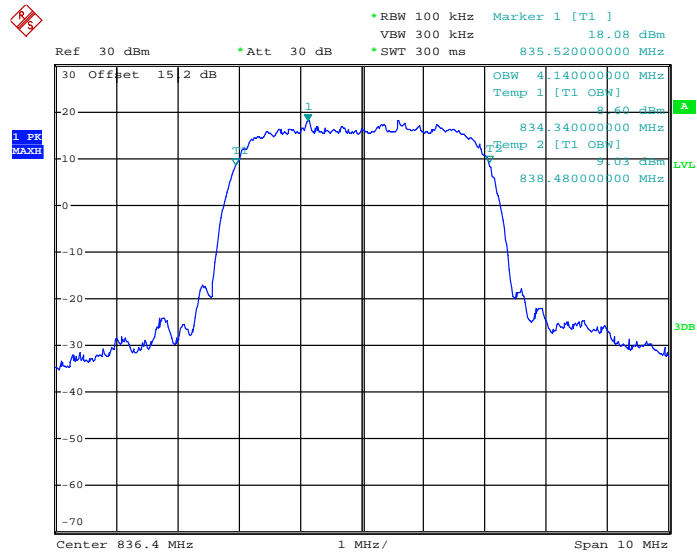

Date: 30.SEP.2015 16:37:33

26dB Bandwidth Plot on Channel 4182 (836.4 MHz)

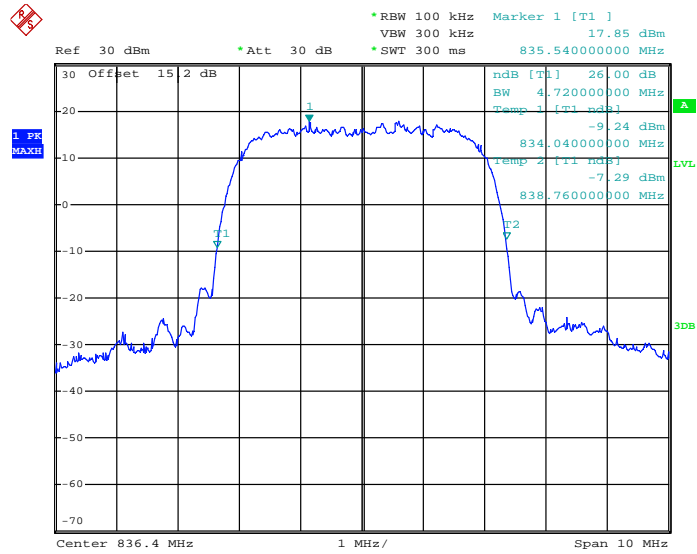

Date: 30.SEP.2015 16:32:17



99% Occupied Bandwidth Plot on Channel 4233 (846.6 MHz)

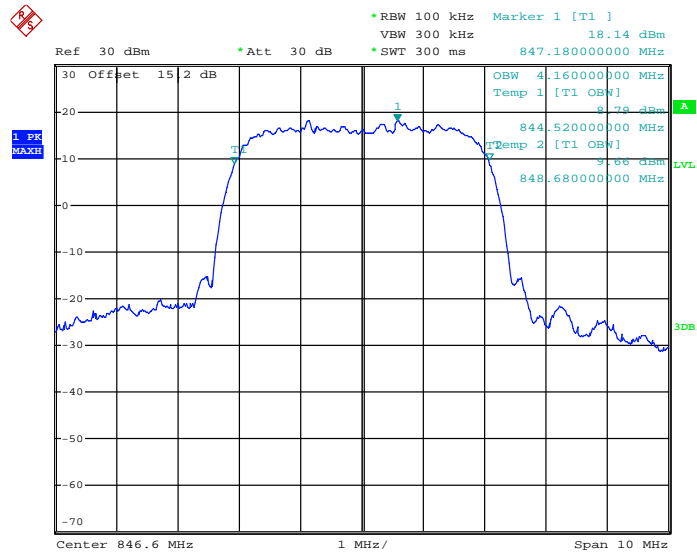

Date: 30.SEP.2015 16:34:48

26dB Bandwidth Plot on Channel 4233 (846.6 MHz)

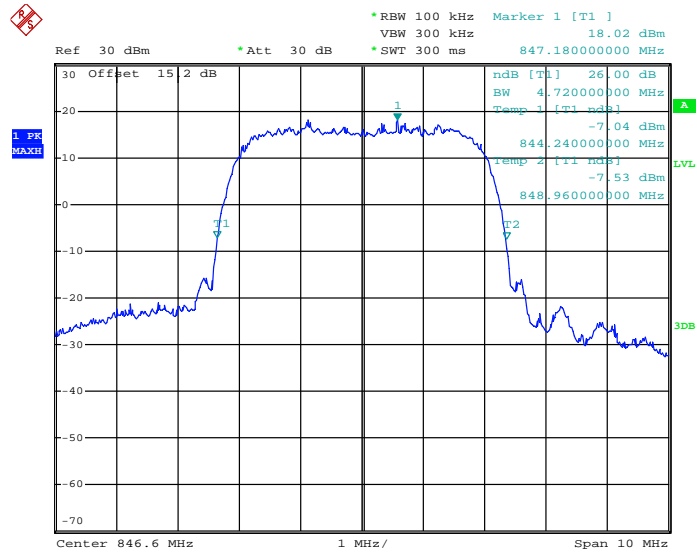

Date: 30.SEP.2015 16:32:45



Band :	WCDMA Band IV	Test Mode :	RMC 12.2Kbps Link (QPSK)
---------------	---------------	--------------------	--------------------------

99% Occupied Bandwidth Plot on Channel 1312 (1712.4 MHz)

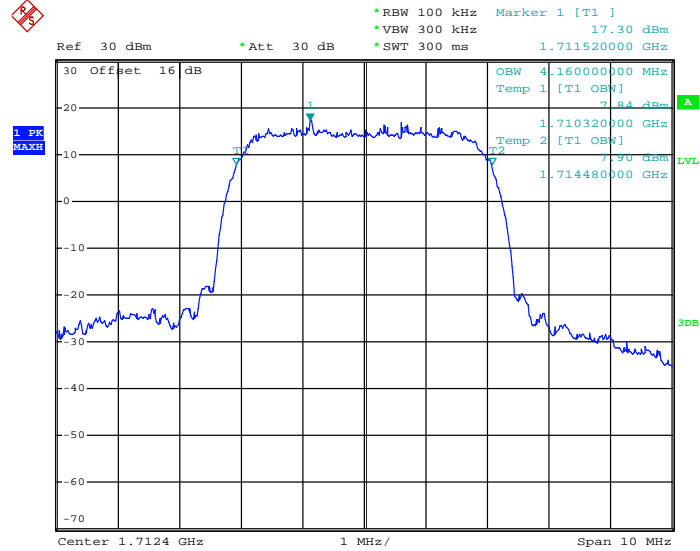

Date: 29.AUG.2015 07:45:26

26dB Bandwidth Plot on Channel 1312 (1712.4 MHz)

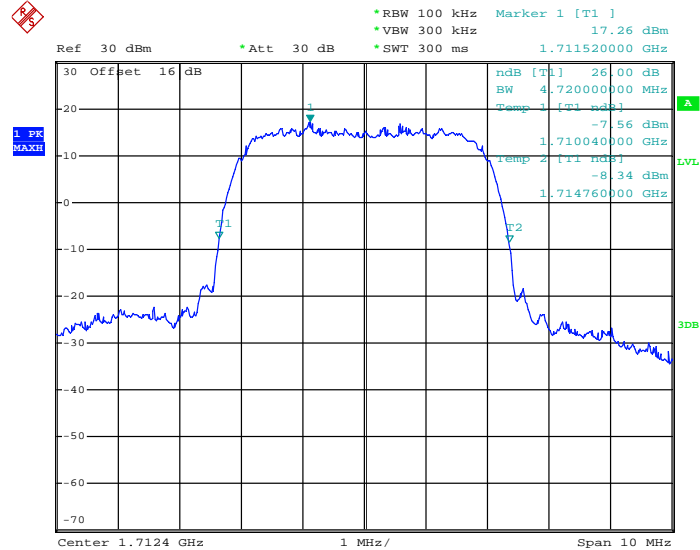

Date: 29.AUG.2015 07:43:44



99% Occupied Bandwidth Plot on Channel 1413 (1732.6 MHz)

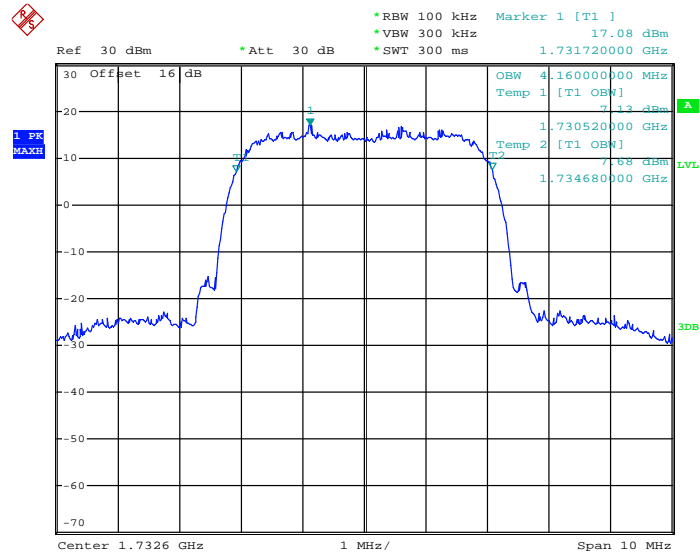

Date: 29.AUG.2015 07:45:12

26dB Bandwidth Plot on Channel 1413 (1732.6 MHz)

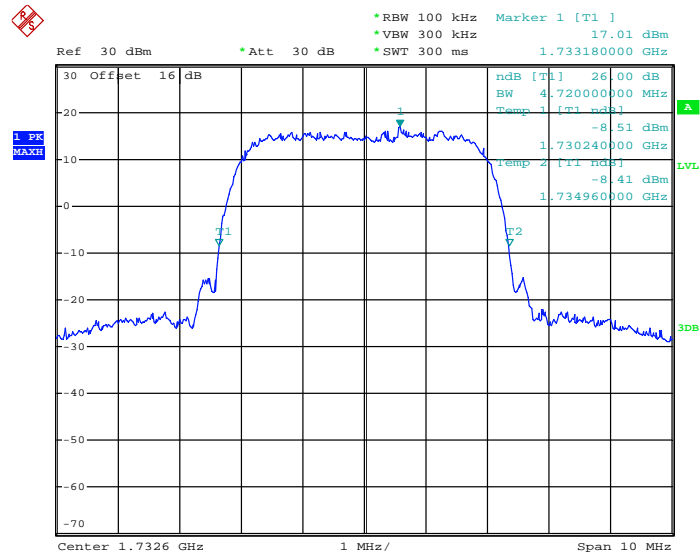

Date: 29.AUG.2015 07:44:15



99% Occupied Bandwidth Plot on Channel 1513 (1752.6 MHz)

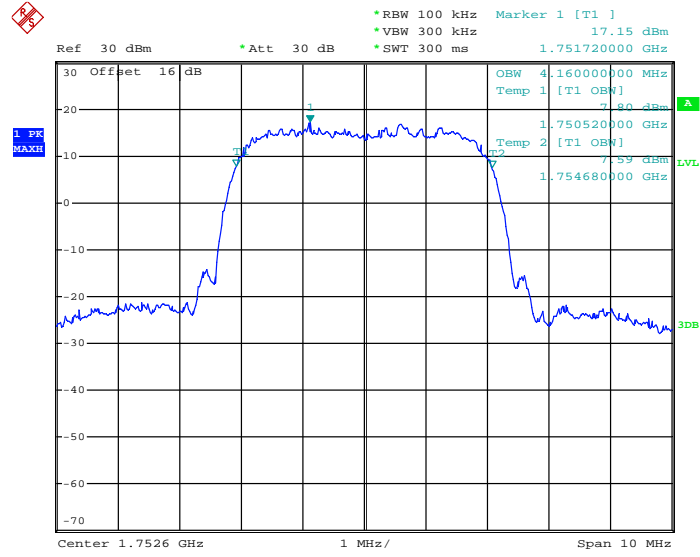

Date: 29.AUG.2015 07:44:56

26dB Bandwidth Plot on Channel 1513 (1752.6 MHz)

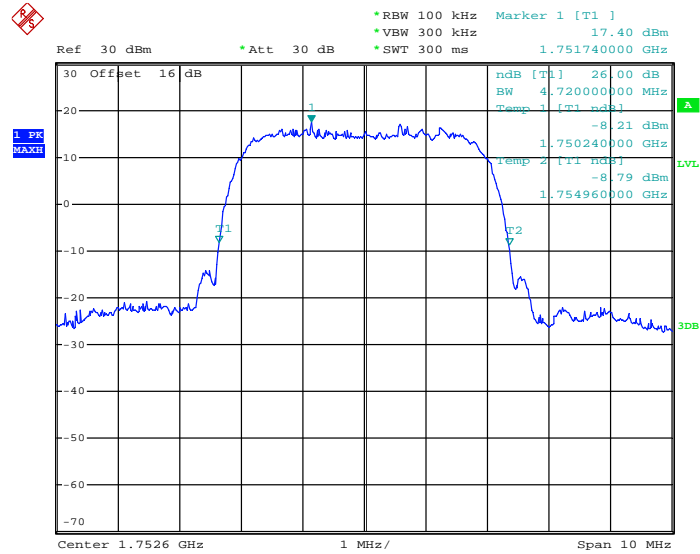

Date: 29.AUG.2015 07:44:36



Band :	WCDMA Band II	Test Mode :	RMC 12.2Kbps Link (QPSK)
---------------	---------------	--------------------	--------------------------

99% Occupied Bandwidth Plot on Channel 9262 (1852.4 MHz)

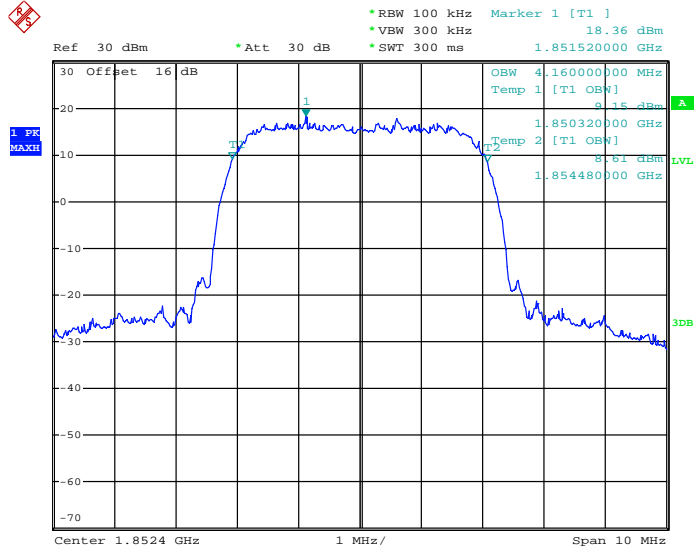

Date: 18.AUG.2015 03:39:59

26dB Bandwidth Plot on Channel 9262 (1852.4 MHz)

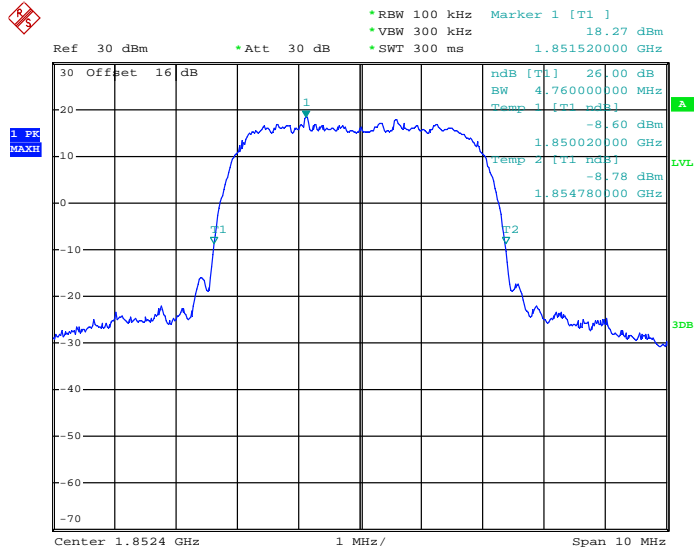

Date: 18.AUG.2015 03:37:25



99% Occupied Bandwidth Plot on Channel 9400 (1880.0 MHz)

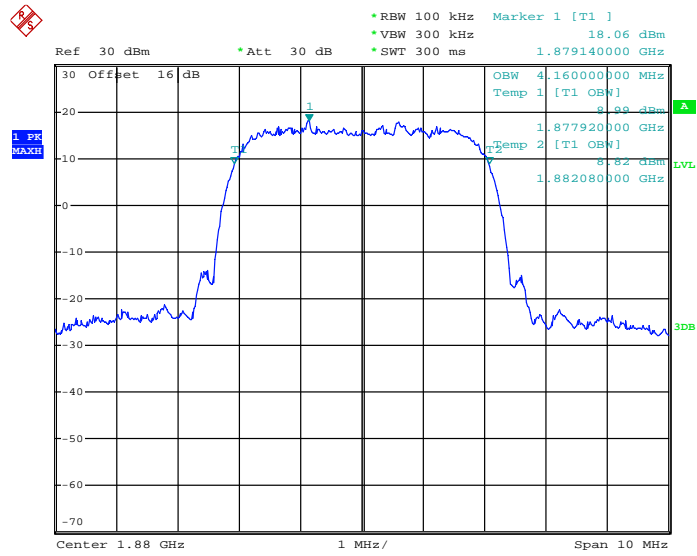

Date: 18.AUG.2015 03:39:37

26dB Bandwidth Plot on Channel 9400 (1880.0 MHz)

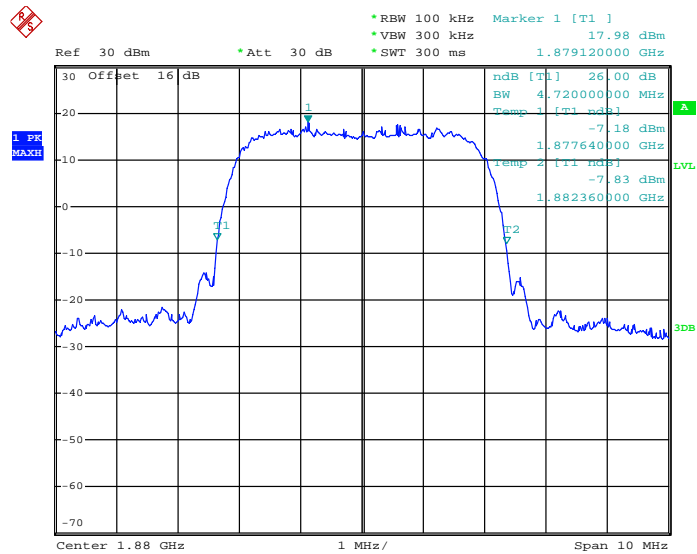

Date: 18.AUG.2015 03:37:45



99% Occupied Bandwidth Plot on Channel 9538 (1907.6 MHz)

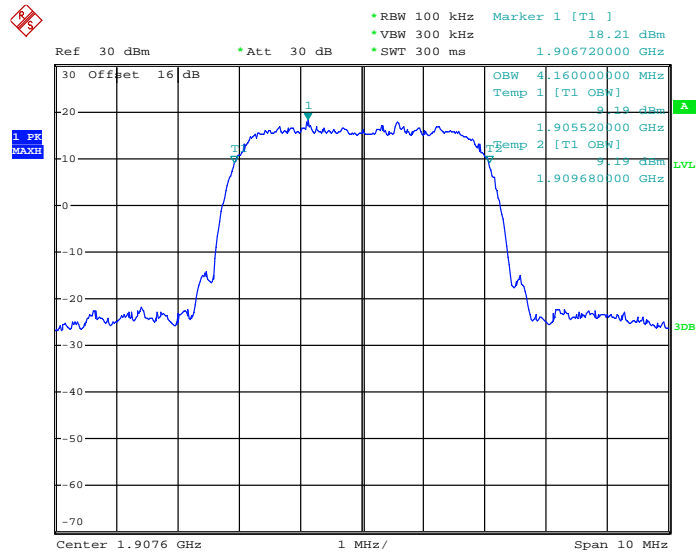

Date: 18.AUG.2015 03:39:13

26dB Bandwidth Plot on Channel 9538 (1907.6 MHz)

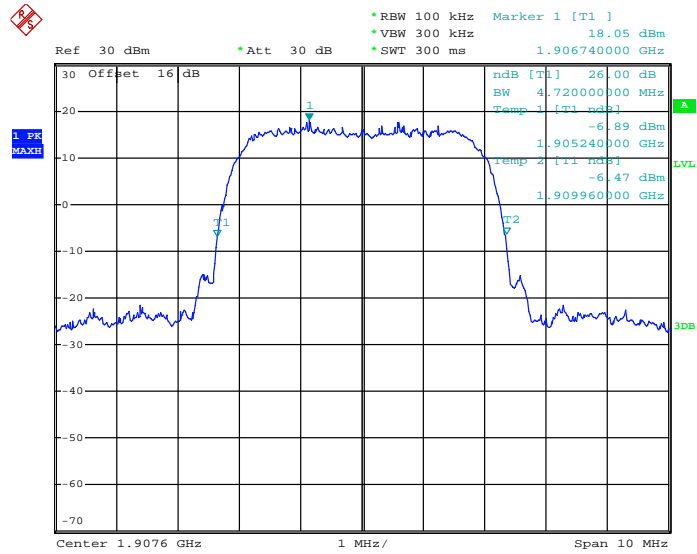

Date: 18.AUG.2015 03:38:11

3.5 Band Edge Measurement

3.5.1 Description of Band Edge Measurement

The power of any emission outside of the authorized operating frequency ranges must be lower than the transmitter power (P) by a factor of at least $43 + 10 \log (P)$ dB.

3.5.2 Measuring Instruments

The measuring equipment is listed in the section 4 of this test report.

3.5.3 Test Procedures

1. The testing follows FCC KDB 971168 v02r02 Section 6.0.
2. The EUT was connected to the spectrum analyzer and system simulator via a power divider.
3. The RF output of EUT was connected to the spectrum analyzer by an RF cable and attenuator. The path loss was compensated to the results for each measurement.
4. The band edges of low and high channels for the highest RF powers were measured.
5. The RF fundamental frequency should be excluded against the limit line in the operating frequency band.
6. The limit line is derived from $43 + 10\log(P)$ dB below the transmitter power P(Watts)
 $= P(W) - [43 + 10\log(P)] \text{ (dB)}$
 $= [30 + 10\log(P)] \text{ (dBm)} - [43 + 10\log(P)] \text{ (dB)}$
 $= -13\text{dBm}.$

3.5.4 Test Setup

<Conducted Band Edge >

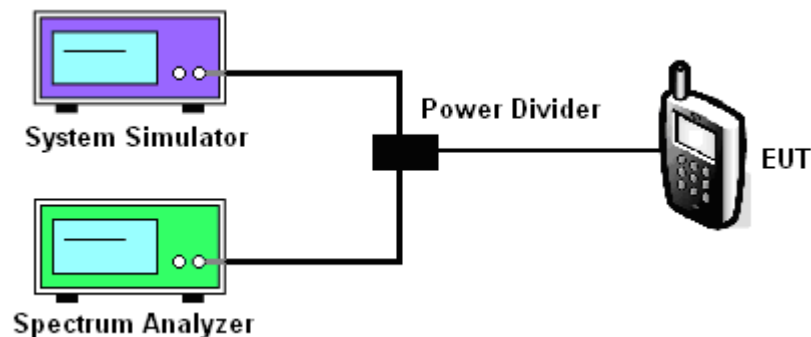



3.5.5 Test Result (Plots) of Conducted Band Edge

Band :	GSM850	Test Mode :	GSM Link (GMSK)
--------	--------	-------------	-----------------

Lower Band Edge Plot on Channel 128 (824.2 MHz)

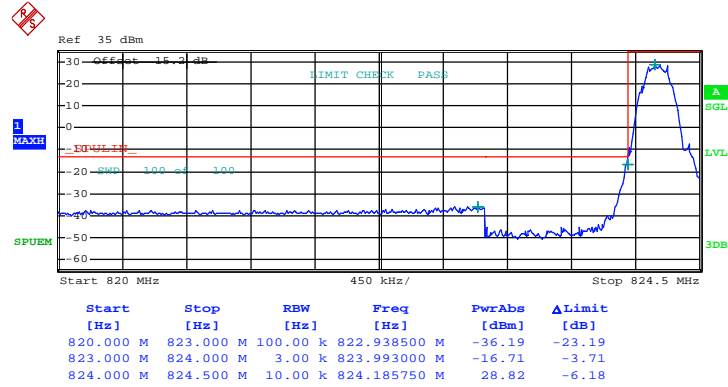

Date: 17.AUG.2015 22:31:49



Band :	GSM850	Test Mode :	GSM Link (GMSK)
--------	--------	-------------	-----------------

Higher Band Edge Plot on Channel 251 (848.8 MHz)

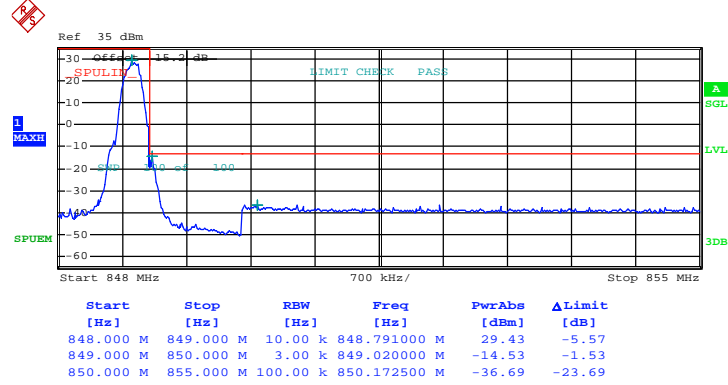

Date: 17.AUG.2015 22:37:03



Band :	GSM850	Test Mode :	EDGE class 8 Link (8PSK)
--------	--------	-------------	--------------------------

Lower Band Edge Plot on Channel 128 (824.2 MHz)

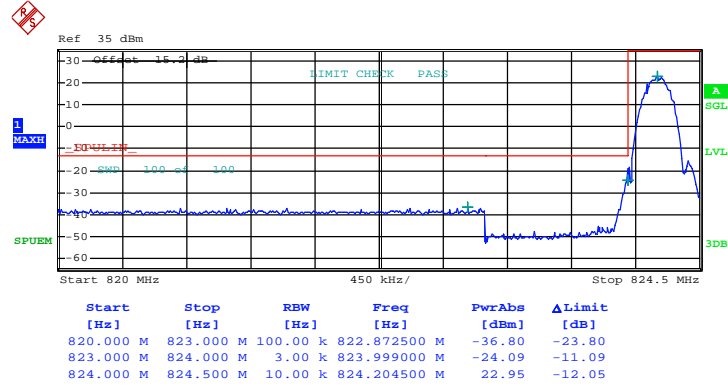

Date: 17.AUG.2015 22:49:07



Band :	GSM850	Test Mode :	EDGE class 8 Link (8PSK)
--------	--------	-------------	--------------------------

Higher Band Edge Plot on Channel 251 (848.8 MHz)

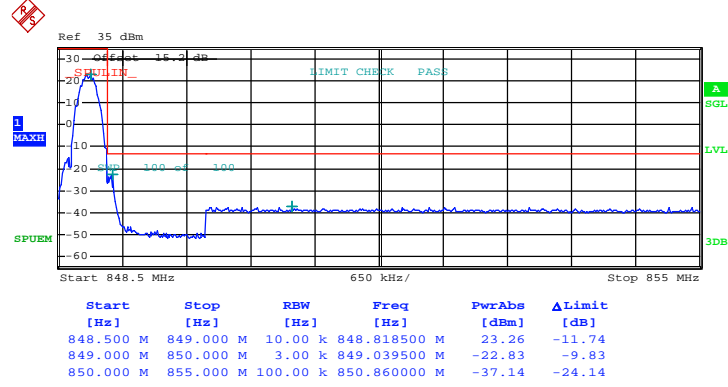

Date: 17.AUG.2015 22:46:21



Band :	GSM1900	Test Mode :	GSM Link (GMSK)
--------	---------	-------------	-----------------

Lower Band Edge Plot on Channel 512 (1850.2 MHz)

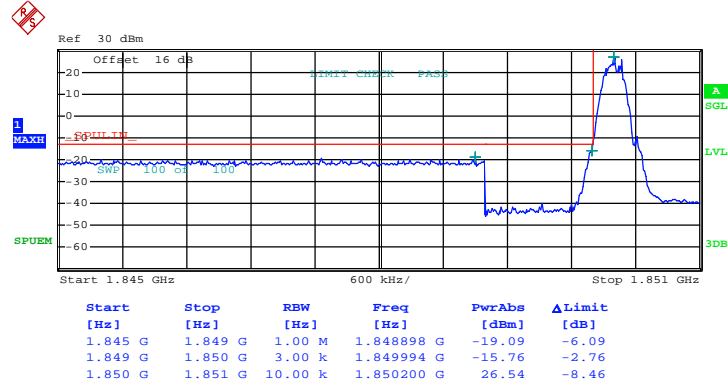

Date: 18.AUG.2015 04:29:32



Band :	GSM1900	Test Mode :	GSM Link (GMSK)
--------	---------	-------------	-----------------

Higher Band Edge Plot on Channel 810 (1909.8 MHz)

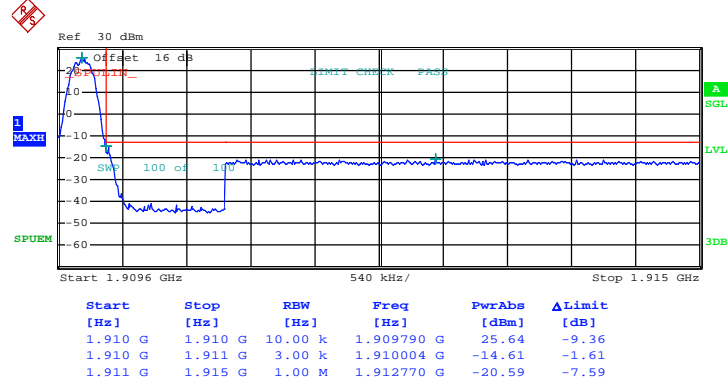

Date: 18.AUG.2015 04:31:17



Band :	GSM1900	Test Mode :	EDGE class 8 Link (8PSK)
--------	---------	-------------	--------------------------

Lower Band Edge Plot on Channel 512 (1850.2 MHz)

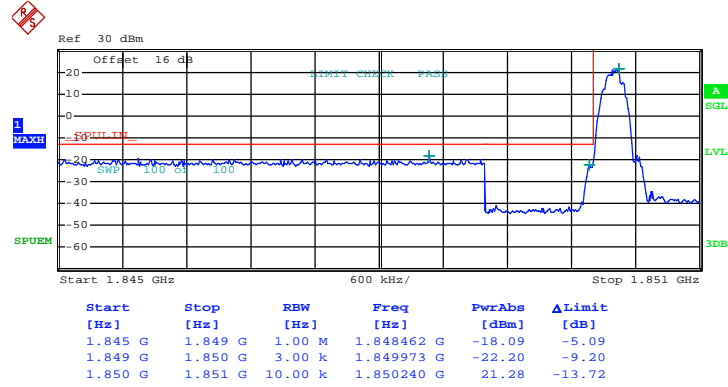

Date: 9.SEP.2015 21:50:40



Band :	GSM1900	Test Mode :	EDGE class 8 Link (8PSK)
--------	---------	-------------	--------------------------

Higher Band Edge Plot on Channel 810 (1909.8 MHz)

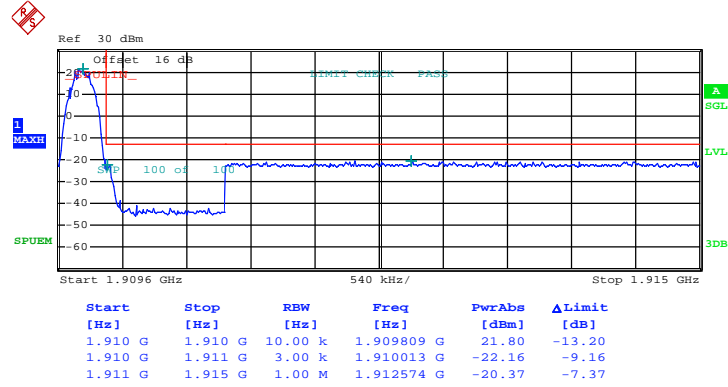

Date: 9.SEP.2015 21:52:24



Band :	WCDMA Band V	Test Mode :	RMC 12.2Kbps Link (QPSK)
--------	--------------	-------------	--------------------------

Lower Band Edge Plot on Channel 4132 (826.4 MHz)

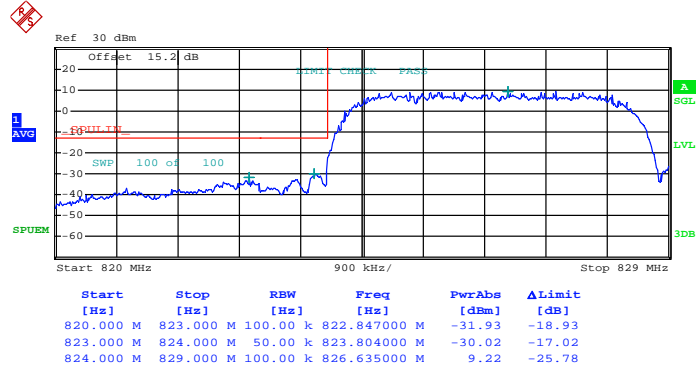

Date: 30.SEP.2015 16:10:36



Band :	WCDMA Band V	Test Mode :	RMC 12.2Kbps Link (QPSK)
--------	--------------	-------------	--------------------------

Higher Band Edge Plot on Channel 4233 (846.6 MHz)

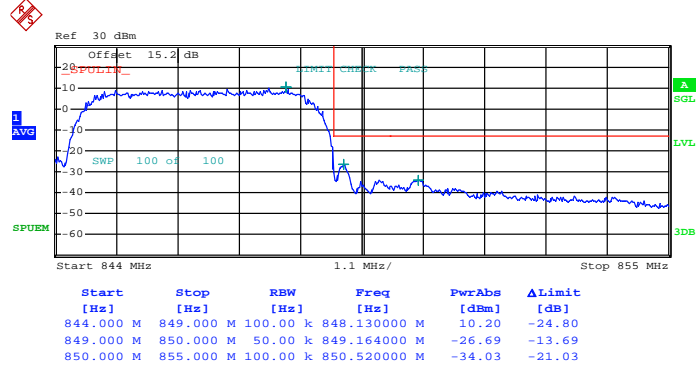

Date: 30.SEP.2015 16:03:54



Band :	WCDMA Band IV	Test Mode :	RMC 12.2Kbps Link (QPSK)
--------	---------------	-------------	--------------------------

Lower Band Edge Plot on Channel 1312 (1712.4 MHz)

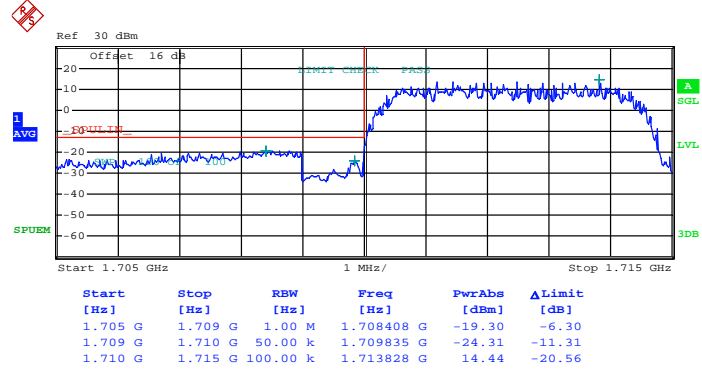

Date: 29.AUG.2015 07:50:11



Band :	WCDMA Band IV	Test Mode :	RMC 12.2Kbps Link (QPSK)
--------	---------------	-------------	--------------------------

Higher Band Edge Plot on Channel 1513 (1752.6 MHz)

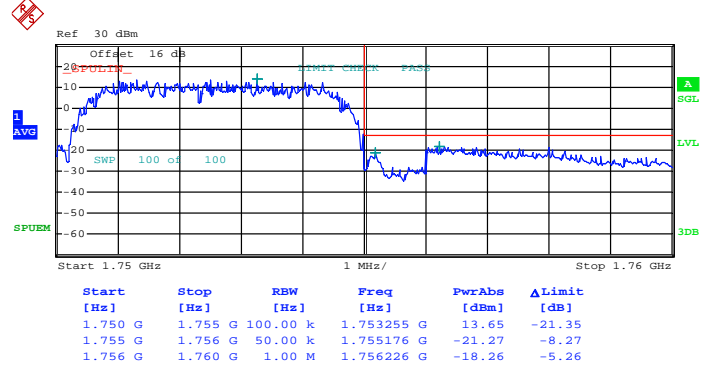

Date: 29.AUG.2015 07:51:49



Band :	WCDMA Band II	Test Mode :	RMC 12.2Kbps Link (QPSK)
--------	---------------	-------------	--------------------------

Lower Band Edge Plot on Channel 9262 (1852.4 MHz)

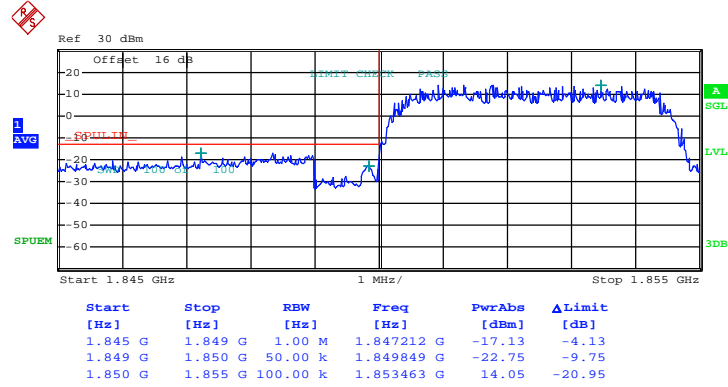

Date: 18.AUG.2015 03:46:44



Band :	WCDMA Band II	Test Mode :	RMC 12.2Kbps Link (QPSK)
--------	---------------	-------------	--------------------------

Higher Band Edge Plot on Channel 9538 (1907.6 MHz)

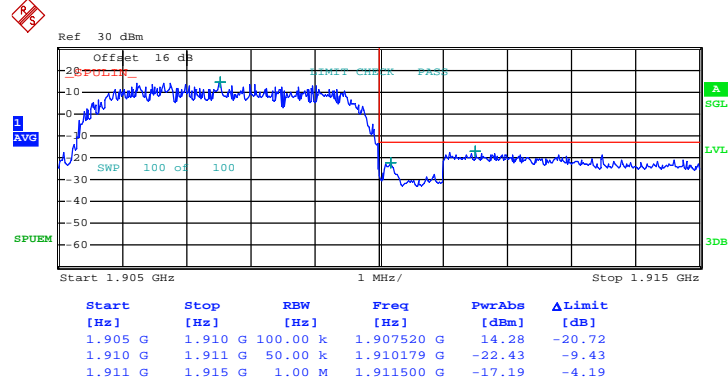

Date: 18.AUG.2015 03:48:34

3.6 Conducted Spurious Emission Measurement

3.6.1 Description of Conducted Spurious Emission Measurement

The power of any emission outside of the authorized operating frequency ranges must be lower than the transmitter power (P) by a factor of at least $43 + 10 \log (P)$ dB.

It is measured by means of a calibrated spectrum analyzer and scanned from 30 MHz up to a frequency including its 10th harmonic.

3.6.2 Measuring Instruments

The measuring equipment is listed in the section 4 of this test report.

3.6.3 Test Procedures

1. The testing follows FCC KDB 971168 v02r02 Section 6.0.
2. The EUT was connected to the spectrum analyzer and system simulator via a power divider.
3. The RF output of EUT was connected to the spectrum analyzer by an RF cable and attenuator. The path loss was compensated to the results for each measurement.
4. The middle channel for the highest RF power within the transmitting frequency was measured.
5. The conducted spurious emission for the whole frequency range was taken.
6. The RF fundamental frequency should be excluded against the limit line in the operating frequency band.
7. The limit line is derived from $43 + 10\log(P)$ dB below the transmitter power P(Watts)
 $= P(W) - [43 + 10\log(P)]$ (dB)
 $= [30 + 10\log(P)]$ (dBm) - $[43 + 10\log(P)]$ (dB)
 $= -13\text{dBm}$.

3.6.4 Test Setup

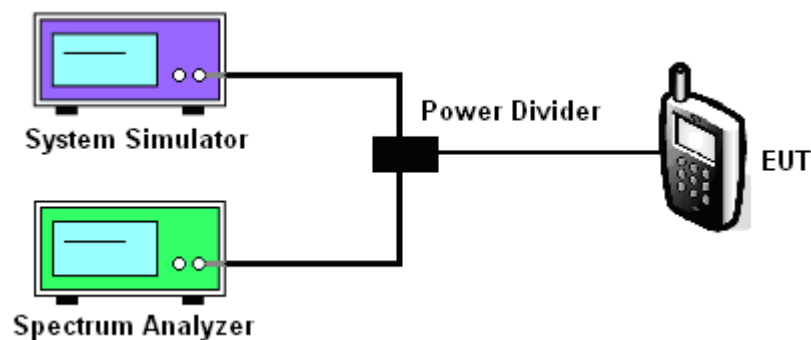



3.6.5 Test Result (Plots) of Conducted Spurious Emission

Band :	GSM850	Channel :	CH128
Test Mode :	GSM Link (GMSK)	Frequency :	824.2 MHz

Conducted Spurious Emission Plot between 30MHz ~ 9GHz

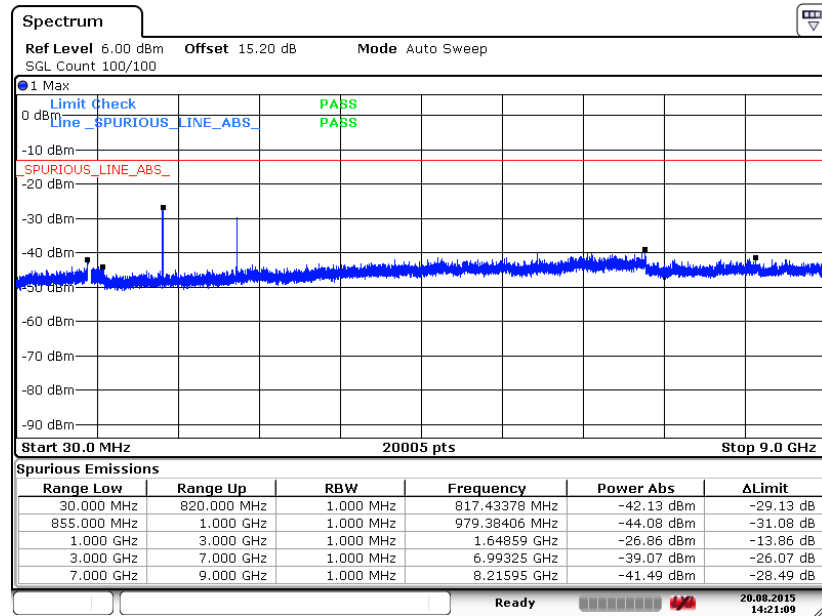

Date: 20 AUG 2015 14:21:09



Band :	GSM850	Channel :	CH189
Test Mode :	GSM Link (GMSK)	Frequency :	836.4 MHz

Conducted Spurious Emission Plot between 30MHz ~ 9GHz

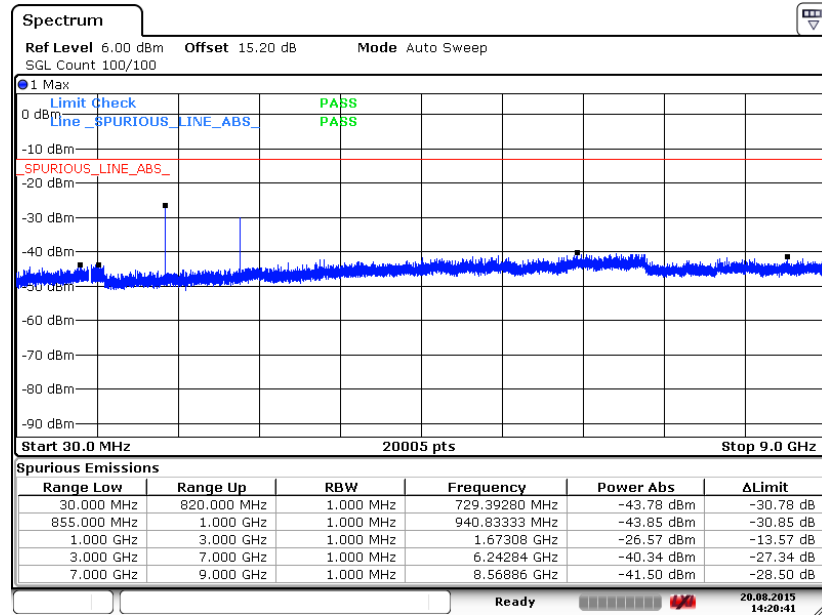

Date: 20 AUG 2015 14:20:40



Band :	GSM850	Channel :	CH251
Test Mode :	GSM Link (GMSK)	Frequency :	848.8 MHz

Conducted Spurious Emission Plot between 30MHz ~ 9GHz

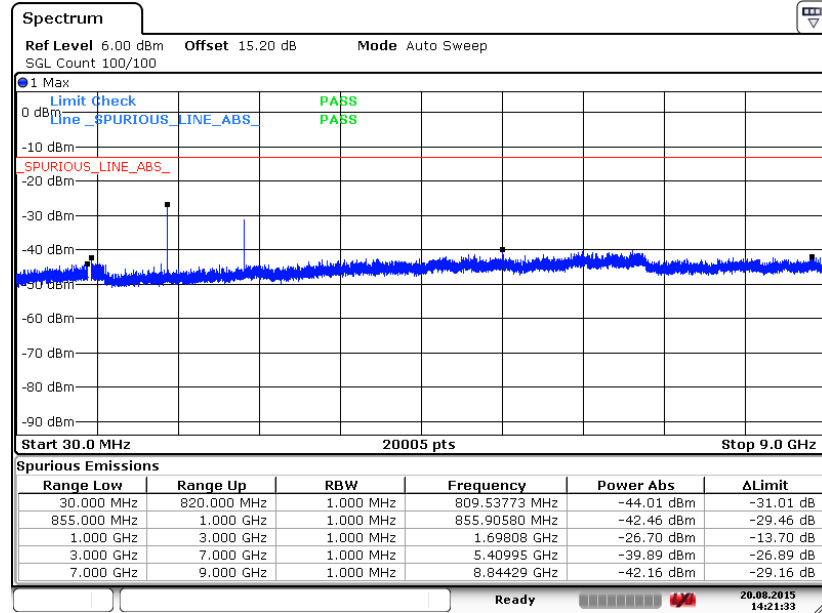

Date: 20 AUG 2015 14:21:33



Band :	GSM850	Channel :	CH128
Test Mode :	EDGE class 8 Link (8PSK)	Frequency :	824.2 MHz

Conducted Spurious Emission Plot between 30MHz ~ 9GHz

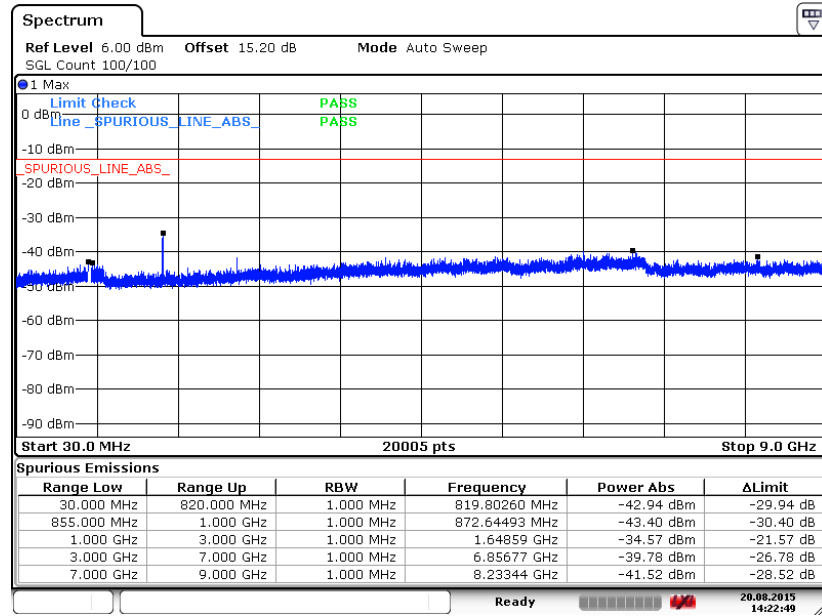

Date: 20 AUG 2015 14:22:50



Band :	GSM850	Channel :	CH189
Test Mode :	EDGE class 8 Link (8PSK)	Frequency :	836.4 MHz

Conducted Spurious Emission Plot between 30MHz ~ 9GHz

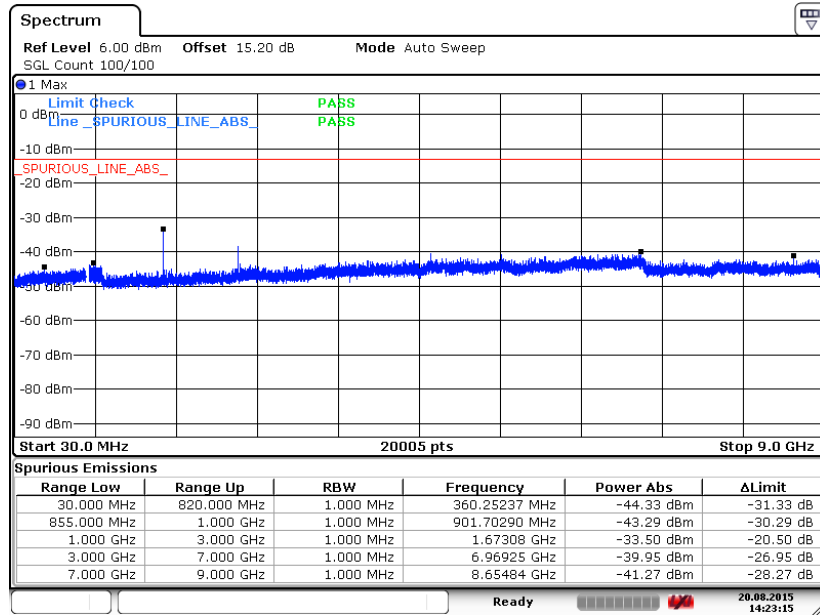

Date: 20 AUG 2015 14:23:14



Band :	GSM850	Channel :	CH251
Test Mode :	EDGE class 8 Link (8PSK)	Frequency :	848.8 MHz

Conducted Spurious Emission Plot between 30MHz ~ 9GHz

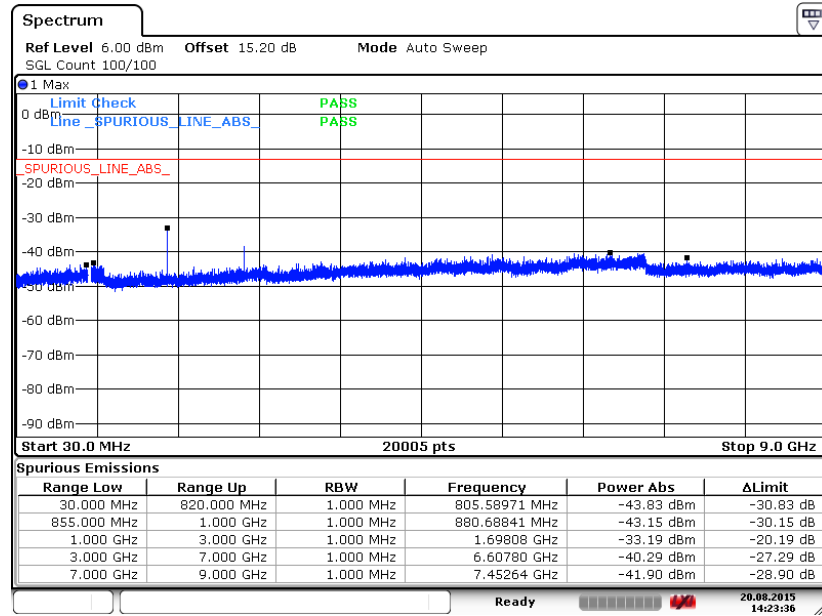

Date: 20 AUG 2015 14:23:36



Band :	GSM1900	Channel :	CH512
Test Mode :	GSM Link (GMSK)	Frequency :	1850.2 MHz

Conducted Spurious Emission Plot between 30MHz ~ 19.1GHz

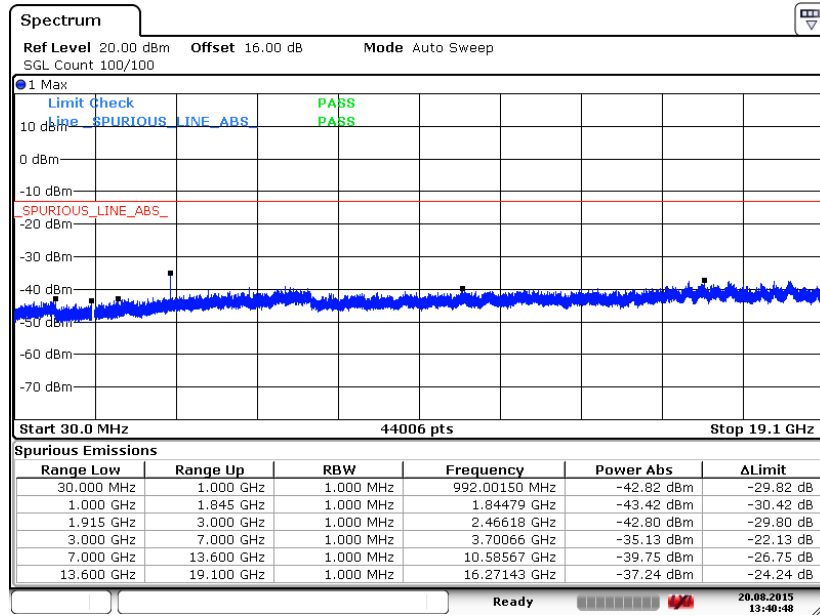

Date: 20 AUG 2015 13:40:48



Band :	GSM1900	Channel :	CH661
Test Mode :	GSM Link (GMSK)	Frequency :	1880.0 MHz

Conducted Spurious Emission Plot between 30MHz ~ 19.1GHz

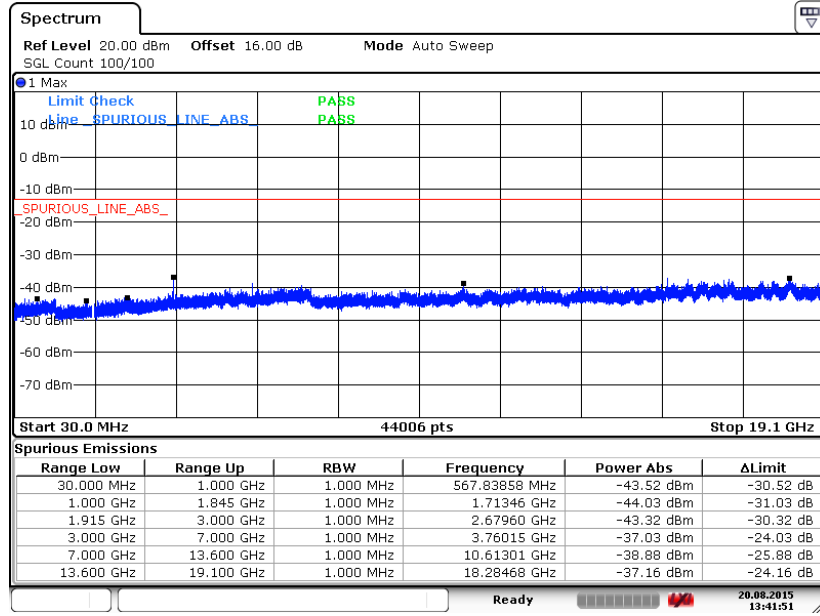

Date: 20 AUG 2015 13:41:51



Band :	GSM1900	Channel :	CH810
Test Mode :	GSM Link (GMSK)	Frequency :	1909.8 MHz

Conducted Spurious Emission Plot between 30MHz ~ 19.1GHz

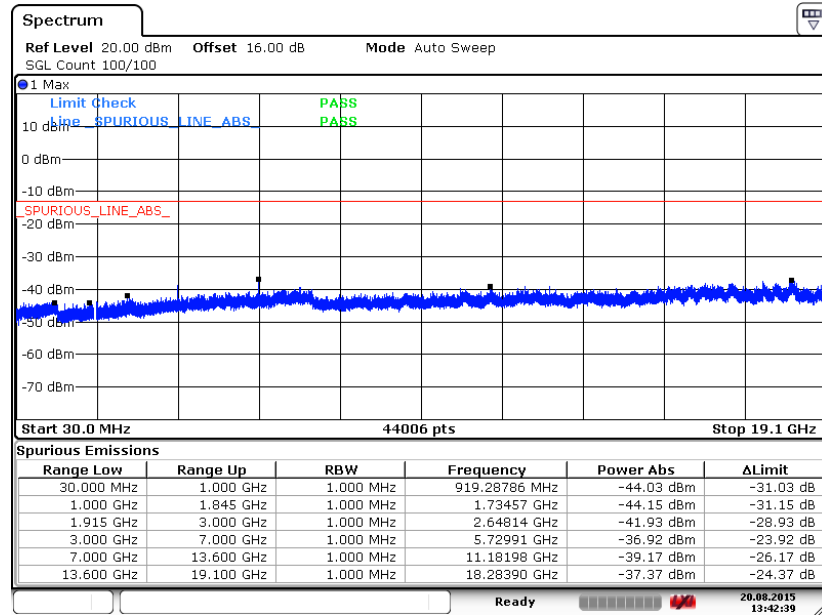

Date: 20 AUG 2015 13:42:39



Band :	GSM1900	Channel :	CH512
Test Mode :	EDGE class 8 Link (8PSK)	Frequency :	1850.2 MHz

Conducted Spurious Emission Plot between 30MHz ~ 19.1GHz

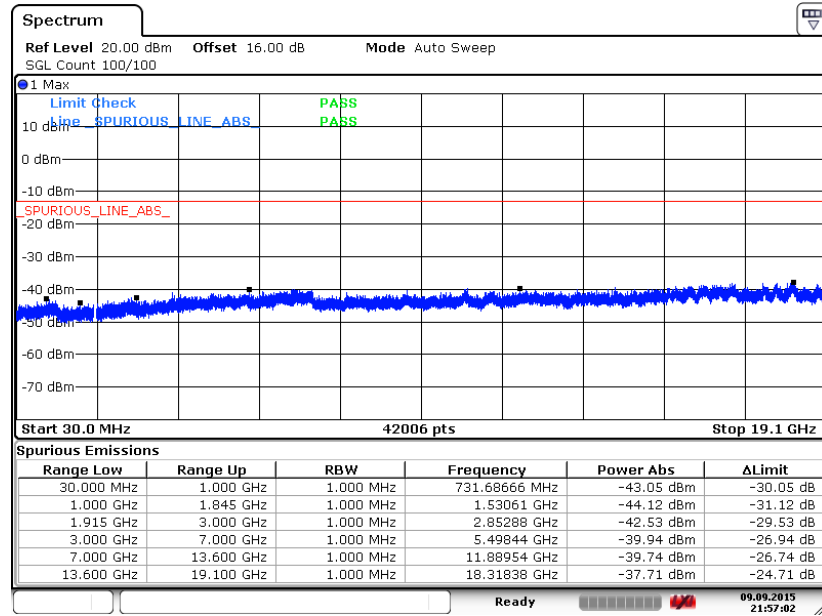

Date: 9 SEP 2015 21:57:02



Band :	GSM1900	Channel :	CH661
Test Mode :	EDGE class 8 Link (8PSK)	Frequency :	1880.0 MHz

Conducted Spurious Emission Plot between 30MHz ~ 19.1GHz

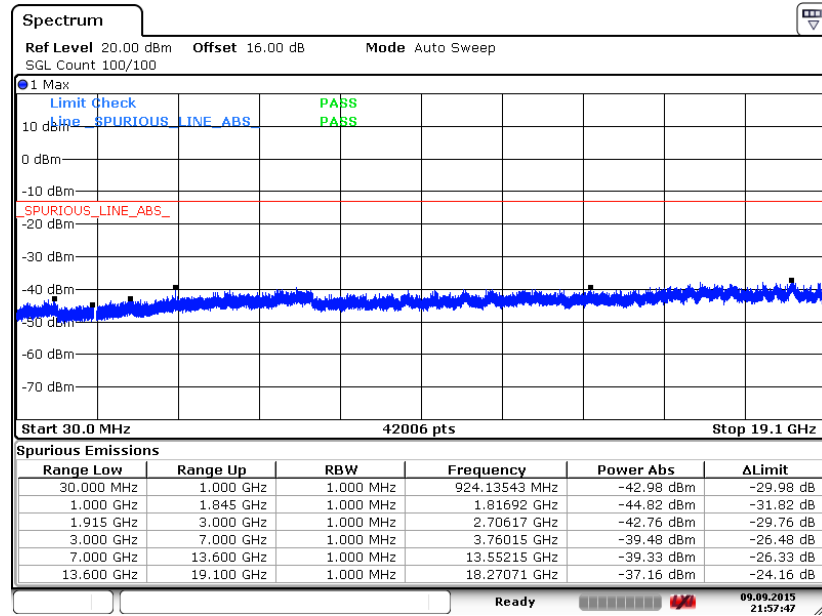

Date: 9 SEP 2015 21:57:47



Band :	GSM1900	Channel :	CH810
Test Mode :	EDGE class 8 Link (8PSK)	Frequency :	1909.8 MHz

Conducted Spurious Emission Plot between 30MHz ~ 19.1GHz

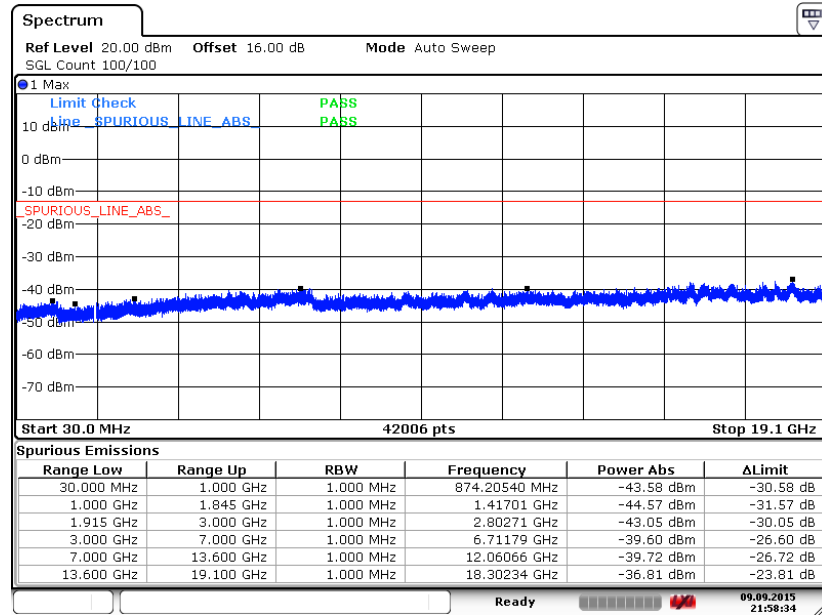

Date: 9 SEP 2015 21:58:34



Band :	WCDMA Band V	Channel :	CH4132
Test Mode :	RMC 12.2Kbps Link (QPSK)	Frequency :	826.4 MHz

Conducted Spurious Emission Plot between 30MHz ~ 9GHz

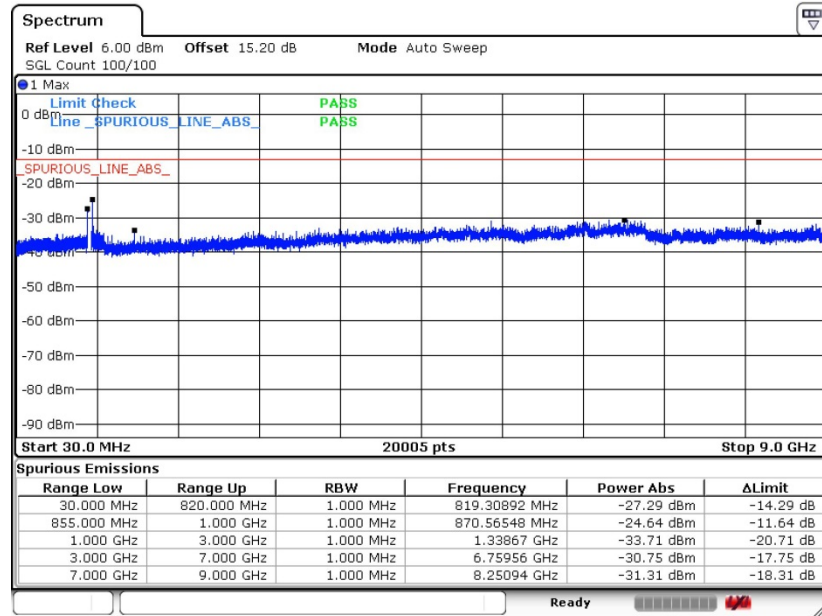

Date: 30.SEP.2015 18:12:24



Band :	WCDMA Band V	Channel :	CH4182
Test Mode :	RMC 12.2Kbps Link (QPSK)	Frequency :	836.4 MHz

Conducted Spurious Emission Plot between 30MHz ~ 9GHz

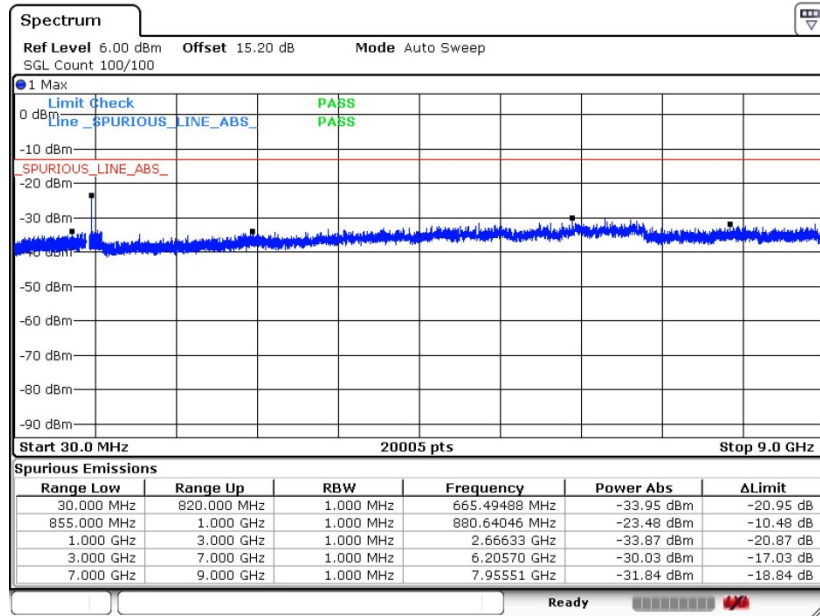

Date: 30.SEP.2015 18:13:01



Band :	WCDMA Band V	Channel :	CH4233
Test Mode :	RMC 12.2Kbps Link (QPSK)	Frequency :	846.6 MHz

Conducted Spurious Emission Plot between 30MHz ~ 9GHz

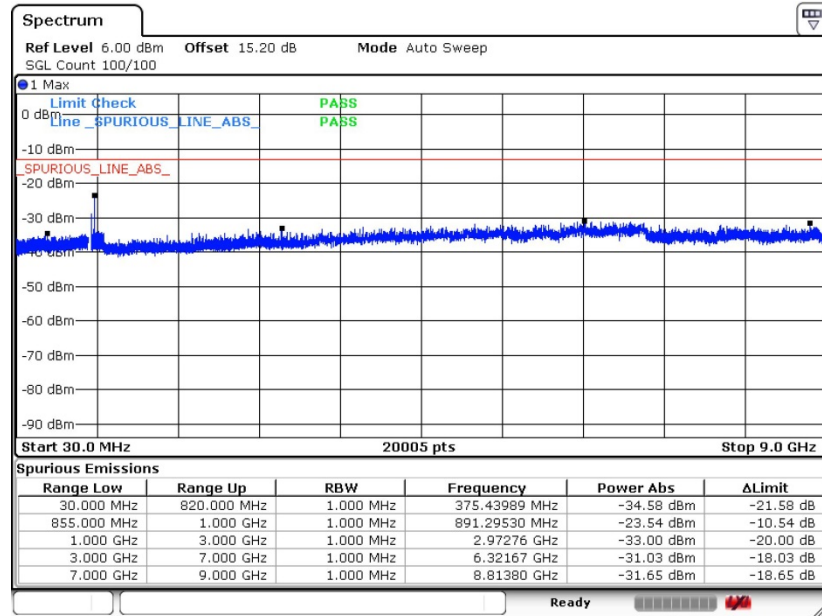

Date: 30.SEP.2015 18:13:42



Band :	WCDMA Band IV	Channel :	CH1312
Test Mode :	RMC 12.2Kbps Link (QPSK)	Frequency :	1712.4 MHz

Conducted Spurious Emission Plot between 30MHz ~ 18GHz

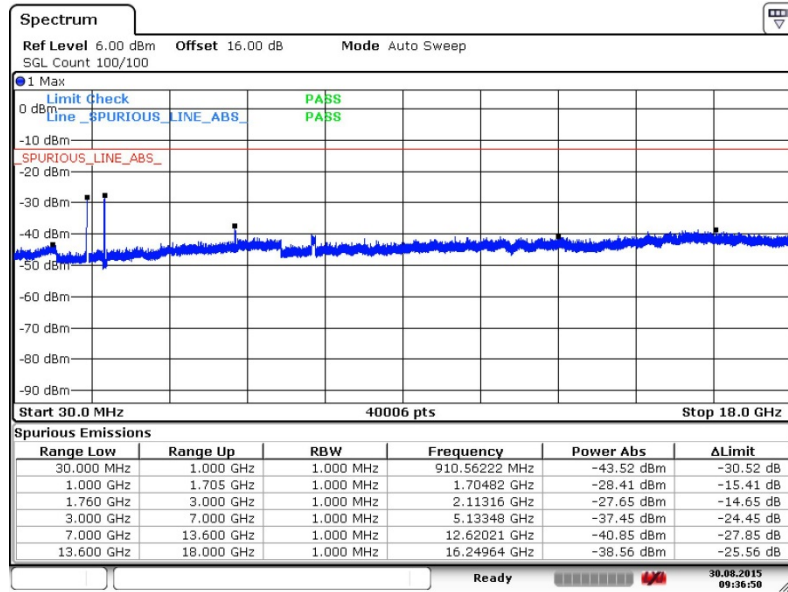

Date: 30.AUG.2015 09:36:50



Band :	WCDMA Band IV	Channel :	CH1413
Test Mode :	RMC 12.2Kbps Link (QPSK)	Frequency :	1732.6 MHz

Conducted Spurious Emission Plot between 30MHz ~ 18GHz

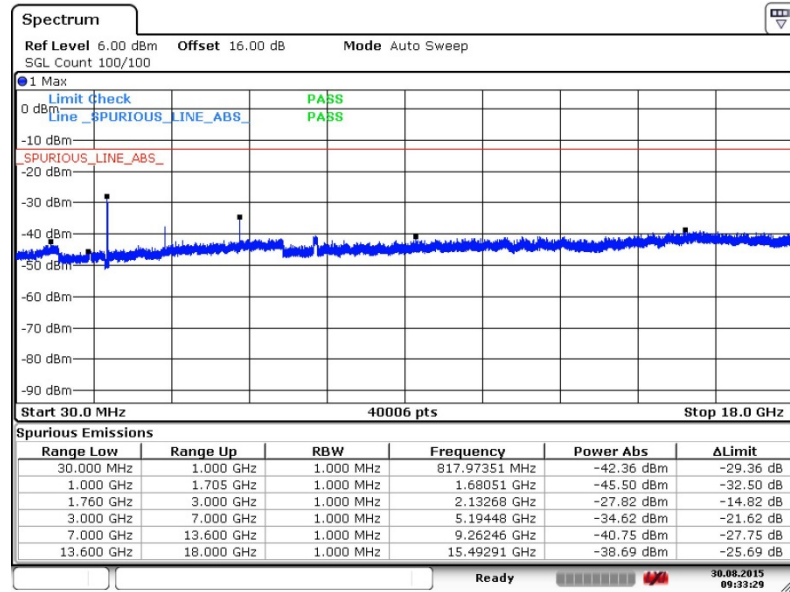

Date: 30.AUG.2015 09:33:29



Band :	WCDMA Band IV	Channel :	CH1513
Test Mode :	RMC 12.2Kbps Link (QPSK)	Frequency :	1752.6 MHz

Conducted Spurious Emission Plot between 30MHz ~ 18GHz

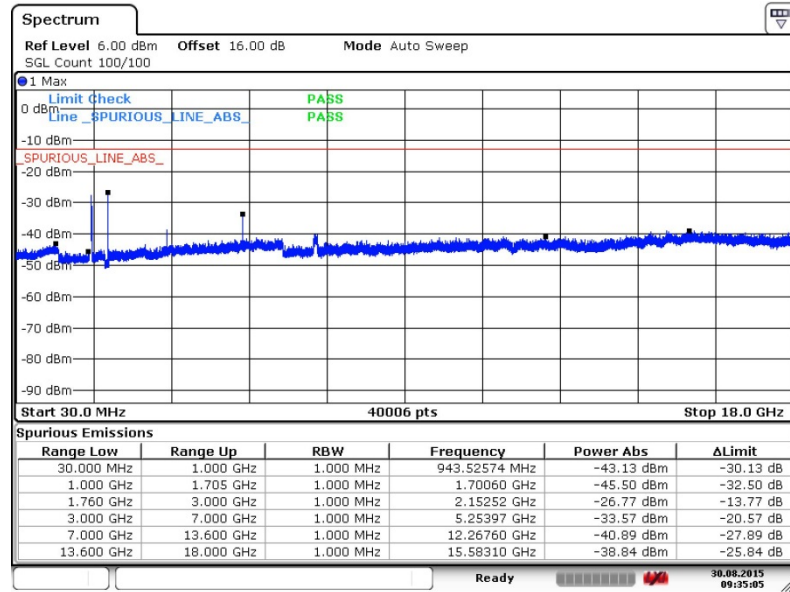

Date: 30.AUG.2015 09:35:04



Band :	WCDMA Band II	Channel :	CH9262
Test Mode :	RMC 12.2Kbps Link (QPSK)	Frequency :	1852.4 MHz

Conducted Spurious Emission Plot between 30MHz ~ 19.1GHz

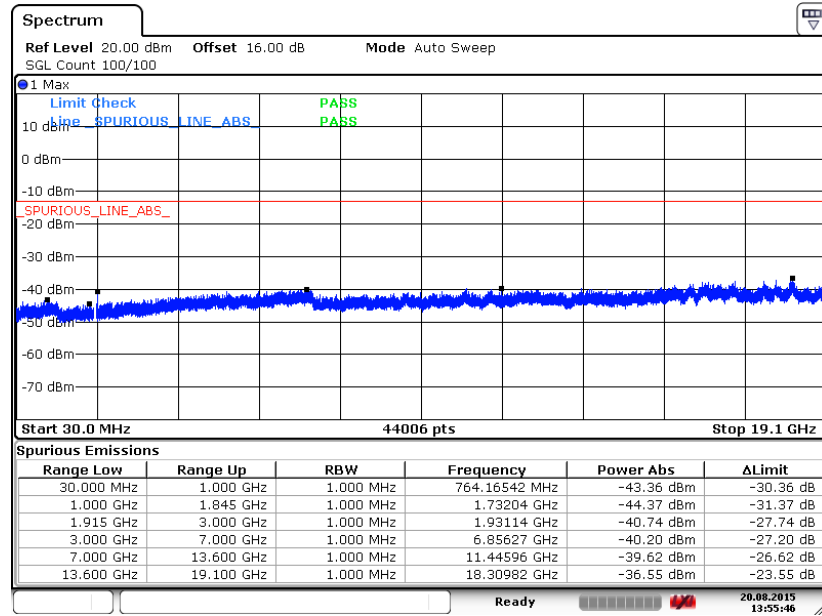

Date: 20 AUG 2015 13:55:46



Band :	WCDMA Band II	Channel :	CH9400
Test Mode :	RMC 12.2Kbps Link (QPSK)	Frequency :	1880.0 MHz

Conducted Spurious Emission Plot between 30MHz ~ 19.1GHz

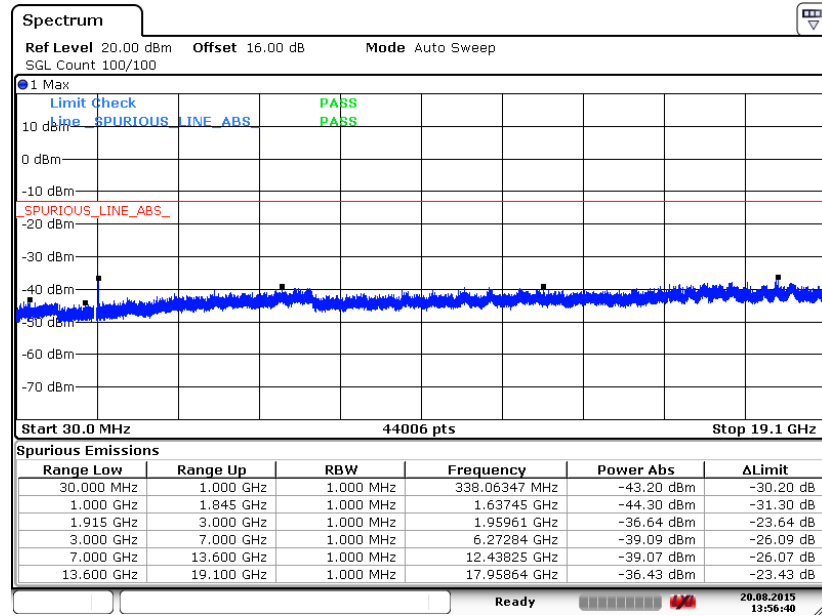

Date: 20 AUG 2015 13:56:39



Band :	WCDMA Band II	Channel :	CH9538
Test Mode :	RMC 12.2Kbps Link (QPSK)	Frequency :	1907.6 MHz

Conducted Spurious Emission Plot between 30MHz ~ 19.1GHz

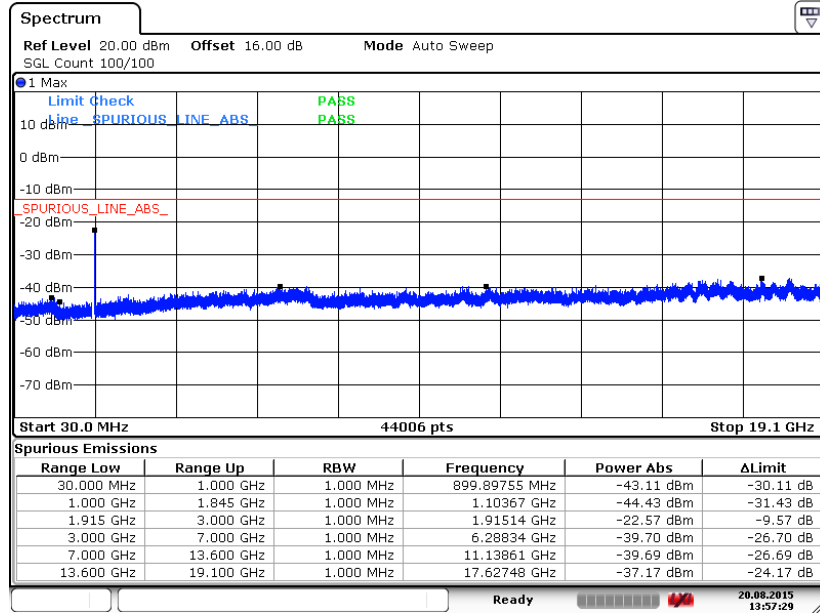

Date: 20 AUG 2015 13:57:30



3.7 Field Strength of Spurious Radiation Measurement

3.7.1 Description of Field Strength of Spurious Radiated Measurement

The power of any emission outside of the authorized operating frequency ranges must be attenuated below the transmitter power (P) by a factor of at least $43 + 10 \log (P)$ dB. The spectrum is scanned from 30 MHz up to a frequency including its 10th harmonic.

3.7.2 Measuring Instruments

The measuring equipment is listed in the section 4 of this test report.

3.7.3 Test Procedures

1. The testing follows FCC KDB 971168 v02r02 Section 5.8 and ANSI / TIA-603-C-2004 Section 2.2.12.
2. The EUT was placed on a rotatable wooden table 0.8 meters above the ground.
3. The EUT was set 3 meters from the receiving antenna, which was mounted on the antenna tower.
4. The table was rotated 360 degrees to determine the position of the highest spurious emission.
5. The height of the receiving antenna is varied between one meter and four meters to search for the maximum spurious emission for both horizontal and vertical polarizations.
6. Make the measurement with the spectrum analyzer's RBW = 1MHz, VBW = 3MHz, taking record of maximum spurious emission.
7. A horn antenna was substituted in place of the EUT and was driven by a signal generator.
8. Tune the output power of signal generator to the same emission level with EUT maximum spurious emission.
9. Taking the record of output power at antenna port.
10. Repeat step 7 to step 8 for another polarization.
11. $EIRP \text{ (dBm)} = S.G. \text{ Power} - Tx \text{ Cable Loss} + Tx \text{ Antenna Gain}$
12. $ERP \text{ (dBm)} = EIRP - 2.15$
13. The RF fundamental frequency should be excluded against the limit line in the operating frequency band.
14. The limit line is derived from $43 + 10\log(P)$ dB below the transmitter power P(Watts)
= $P(W) - [43 + 10\log(P)] \text{ (dB)}$
= $[30 + 10\log(P)] \text{ (dBm)} - [43 + 10\log(P)] \text{ (dB)}$
= -13dBm.

3.7.4 Test Setup

For radiated emissions from 30MHz to 1GHz

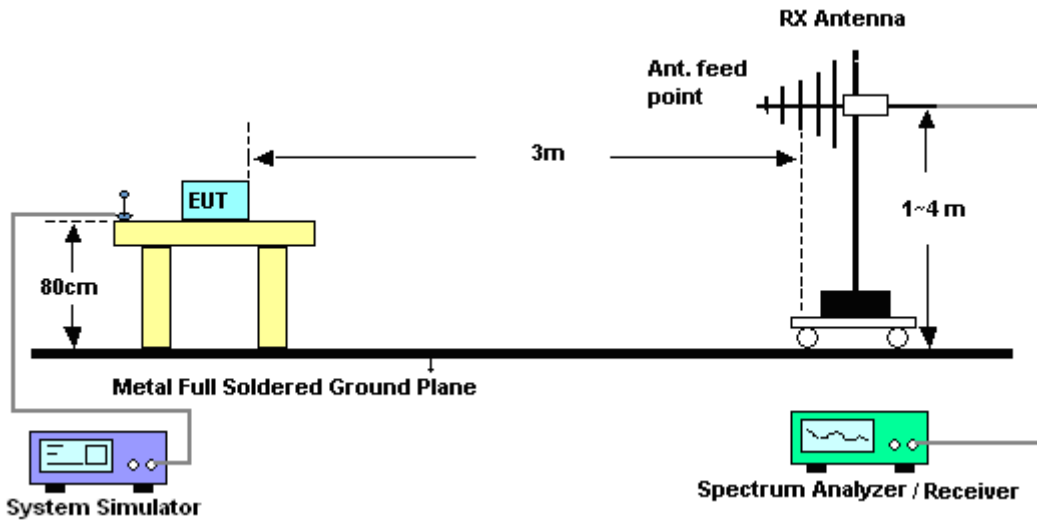

For radiated emissions above 1GHz

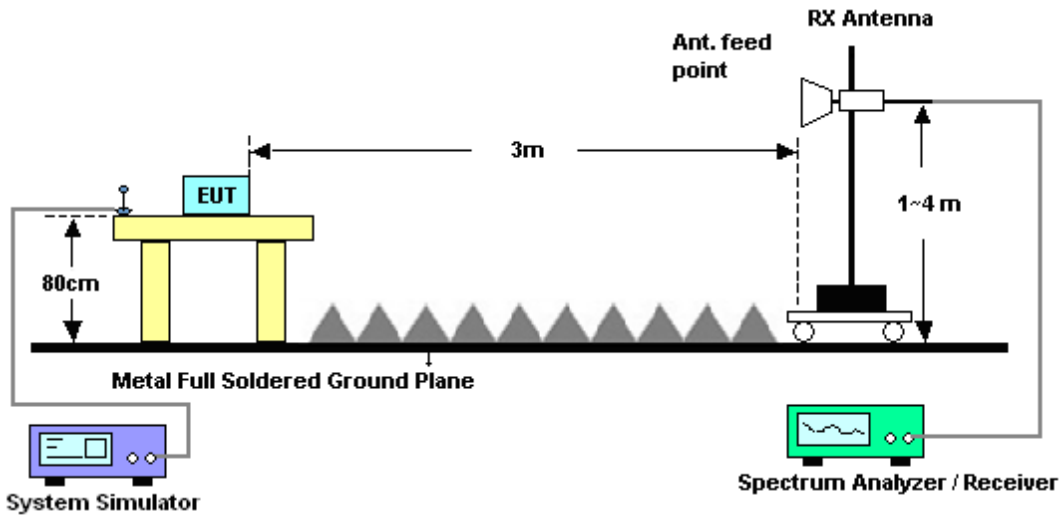



3.7.5 Test Result of Field Strength of Spurious Radiated

Band :	GSM850 for CH128				Temperature :	21~22°C			
Test Mode :	GSM Link (GMSK)				Relative Humidity :	41~42%			
Test Engineer :	Jack Wang				Polarization :	Horizontal			
Remark :	Spurious emissions within 30-1000MHz were found more than 20dB below limit line.								
Frequency (MHz)	ERP (dBm)	Limit (dBm)	Over Limit (dB)	SPA Reading (dBm)	S.G. Power (dBm)	TX Cable loss (dB)	TX Antenna Gain (dBi)	Polarization (H/V)	Result
1648	-53.72	-13	-40.72	-55.90	-55.61	1.86	5.90	H	Pass
2474	-55.44	-13	-42.44	-64.47	-57.78	2.31	6.80	H	Pass
3297	-53.71	-13	-40.71	-66.34	-56.11	2.85	7.40	H	Pass

Band :	GSM850 for CH128				Temperature :	21~22°C			
Test Mode :	GSM Link (GMSK)				Relative Humidity :	41~42%			
Test Engineer :	Jack Wang				Polarization :	Vertical			
Remark :	Spurious emissions within 30-1000MHz were found more than 20dB below limit line.								
Frequency (MHz)	ERP (dBm)	Limit (dBm)	Over Limit (dB)	SPA Reading (dBm)	S.G. Power (dBm)	TX Cable loss (dB)	TX Antenna Gain (dBi)	Polarization (H/V)	Result
1648	-55.44	-13	-42.44	-55.20	-57.33	1.86	5.90	V	Pass
2474	-52.71	-13	-39.71	-63.68	-55.05	2.31	6.80	V	Pass
3297	-53.61	-13	-40.61	-67.59	-56.01	2.85	7.40	V	Pass



Band :	GSM850 for CH189				Temperature :	21~22°C			
Test Mode :	GSM Link (GMSK)				Relative Humidity :	41~42%			
Test Engineer :	Jack Wang				Polarization :	Horizontal			
Remark :	Spurious emissions within 30-1000MHz were found more than 20dB below limit line.								
Frequency (MHz)	ERP (dBm)	Limit (dBm)	Over Limit (dB)	SPA Reading (dBm)	S.G. Power (dBm)	TX Cable loss (dB)	TX Antenna Gain (dBi)	Polarization (H/V)	Result
1672	-53.24	-13	-40.24	-55.42	-55.13	1.86	5.90	H	Pass
2509	-55.89	-13	-42.89	-64.92	-58.23	2.31	6.80	H	Pass
3345	-53.22	-13	-40.22	-65.85	-55.62	2.85	7.40	H	Pass

Band :	GSM850 for CH189				Temperature :	21~22°C			
Test Mode :	GSM Link (GMSK)				Relative Humidity :	41~42%			
Test Engineer :	Jack Wang				Polarization :	Vertical			
Remark :	Spurious emissions within 30-1000MHz were found more than 20dB below limit line.								
Frequency (MHz)	ERP (dBm)	Limit (dBm)	Over Limit (dB)	SPA Reading (dBm)	S.G. Power (dBm)	TX Cable loss (dB)	TX Antenna Gain (dBi)	Polarization (H/V)	Result
1672	-52.13	-13	-39.13	-53.06	-54.02	1.86	5.90	V	Pass
2509	-54.24	-13	-41.24	-65.21	-56.58	2.31	6.80	V	Pass
3345	-52.53	-13	-39.53	-66.51	-54.93	2.85	7.40	V	Pass



Band :	GSM850 for CH251				Temperature :	21~22°C			
Test Mode :	GSM Link (GMSK)				Relative Humidity :	41~42%			
Test Engineer :	Jack Wang				Polarization :	Horizontal			
Remark :	Spurious emissions within 30-1000MHz were found more than 20dB below limit line.								
Frequency (MHz)	ERP (dBm)	Limit (dBm)	Over Limit (dB)	SPA Reading (dBm)	S.G. Power (dBm)	TX Cable loss (dB)	TX Antenna Gain (dBi)	Polarization (H/V)	Result
1698	-51.25	-13	-38.25	-53.70	-53.14	1.86	5.90	H	Pass
2548	-56.48	-13	-43.48	-65.51	-58.82	2.31	6.80	H	Pass
3396	-54.13	-13	-41.13	-66.76	-56.53	2.85	7.40	H	Pass

Band :	GSM850 for CH251				Temperature :	21~22°C			
Test Mode :	GSM Link (GMSK)				Relative Humidity :	41~42%			
Test Engineer :	Jack Wang				Polarization :	Vertical			
Remark :	Spurious emissions within 30-1000MHz were found more than 20dB below limit line.								
Frequency (MHz)	ERP (dBm)	Limit (dBm)	Over Limit (dB)	SPA Reading (dBm)	S.G. Power (dBm)	TX Cable loss (dB)	TX Antenna Gain (dBi)	Polarization (H/V)	Result
1698	-50.40	-13	-37.40	-52.63	-52.29	1.86	5.90	V	Pass
2548	-51.26	-13	-38.26	-62.23	-53.60	2.31	6.80	V	Pass
3396	-54.01	-13	-41.01	-67.99	-56.41	2.85	7.40	V	Pass



Band :	GSM850 for CH128					Temperature :	21~22°C		
Test Mode :	EDGE class 8 Link (8PSK)					Relative Humidity :	41~42%		
Test Engineer :	Jack Wang					Polarization :	Horizontal		
Remark :	Spurious emissions within 30-1000MHz were found more than 20dB below limit line.								
Frequency (MHz)	ERP (dBm)	Limit (dBm)	Over Limit (dB)	SPA Reading (dBm)	S.G. Power (dBm)	TX Cable loss (dB)	TX Antenna Gain (dBi)	Polarization (H/V)	Result
1648	-53.98	-13	-40.98	-56.16	-55.87	1.86	5.90	H	Pass
2474	-55.60	-13	-42.60	-64.63	-57.94	2.31	6.80	H	Pass
3297	-54.20	-13	-41.20	-66.83	-56.60	2.85	7.40	H	Pass

Band :	GSM850 for CH128					Temperature :	21~22°C		
Test Mode :	EDGE class 8 Link (8PSK)					Relative Humidity :	41~42%		
Test Engineer :	Jack Wang					Polarization :	Vertical		
Remark :	Spurious emissions within 30-1000MHz were found more than 20dB below limit line.								
Frequency (MHz)	ERP (dBm)	Limit (dBm)	Over Limit (dB)	SPA Reading (dBm)	S.G. Power (dBm)	TX Cable loss (dB)	TX Antenna Gain (dBi)	Polarization (H/V)	Result
1648	-53.34	-13	-40.34	-53.94	-55.23	1.86	5.90	V	Pass
2474	-52.27	-13	-39.27	-63.24	-54.61	2.31	6.80	V	Pass
3297	-53.59	-13	-40.59	-67.57	-55.99	2.85	7.40	V	Pass



Band :	GSM850 for CH189					Temperature :	21~22°C		
Test Mode :	EDGE class 8 Link (8PSK)					Relative Humidity :	41~42%		
Test Engineer :	Jack Wang					Polarization :	Horizontal		
Remark :	Spurious emissions within 30-1000MHz were found more than 20dB below limit line.								
Frequency (MHz)	ERP (dBm)	Limit (dBm)	Over Limit (dB)	SPA Reading (dBm)	S.G. Power (dBm)	TX Cable loss (dB)	TX Antenna Gain (dBi)	Polarization (H/V)	Result
1672	-52.15	-13	-39.15	-54.33	-54.04	1.86	5.90	H	Pass
2509	-55.98	-13	-42.98	-65.01	-58.32	2.31	6.80	H	Pass
3345	-53.41	-13	-40.41	-66.04	-55.81	2.85	7.40	H	Pass

Band :	GSM850 for CH189					Temperature :	21~22°C		
Test Mode :	EDGE class 8 Link (8PSK)					Relative Humidity :	41~42%		
Test Engineer :	Jack Wang					Polarization :	Vertical		
Remark :	Spurious emissions within 30-1000MHz were found more than 20dB below limit line.								
Frequency (MHz)	ERP (dBm)	Limit (dBm)	Over Limit (dB)	SPA Reading (dBm)	S.G. Power (dBm)	TX Cable loss (dB)	TX Antenna Gain (dBi)	Polarization (H/V)	Result
1672	-49.12	-13	-36.12	-51.80	-51.01	1.86	5.90	V	Pass
2509	-53.75	-13	-40.75	-64.72	-56.09	2.31	6.80	V	Pass
3345	-53.19	-13	-40.19	-67.17	-55.59	2.85	7.40	V	Pass



Band :	GSM850 for CH251					Temperature :	21~22°C		
Test Mode :	EDGE class 8 Link (8PSK)					Relative Humidity :	41~42%		
Test Engineer :	Jack Wang					Polarization :	Horizontal		
Remark :	Spurious emissions within 30-1000MHz were found more than 20dB below limit line.								
Frequency (MHz)	ERP (dBm)	Limit (dBm)	Over Limit (dB)	SPA Reading (dBm)	S.G. Power (dBm)	TX Cable loss (dB)	TX Antenna Gain (dBi)	Polarization (H/V)	Result
1698	-50.33	-13	-37.33	-52.78	-52.22	1.86	5.90	H	Pass
2548	-55.91	-13	-42.91	-64.94	-58.25	2.31	6.80	H	Pass
3396	-55.51	-13	-42.51	-68.14	-57.91	2.85	7.40	H	Pass

Band :	GSM850 for CH251					Temperature :	21~22°C		
Test Mode :	EDGE class 8 Link (8PSK)					Relative Humidity :	41~42%		
Test Engineer :	Jack Wang					Polarization :	Vertical		
Remark :	Spurious emissions within 30-1000MHz were found more than 20dB below limit line.								
Frequency (MHz)	ERP (dBm)	Limit (dBm)	Over Limit (dB)	SPA Reading (dBm)	S.G. Power (dBm)	TX Cable loss (dB)	TX Antenna Gain (dBi)	Polarization (H/V)	Result
1698	-49.60	-13	-36.60	-52.18	-51.49	1.86	5.90	V	Pass
2548	-52.83	-13	-39.83	-63.80	-55.17	2.31	6.80	V	Pass
3396	-54.23	-13	-41.23	-68.21	-56.63	2.85	7.40	V	Pass



Band :	GSM1900 for CH512					Temperature :	21~22°C		
Test Mode :	GSM Link (GMSK)					Relative Humidity :	41~42%		
Test Engineer :	Jack Wang					Polarization :	Horizontal		
Remark :	Spurious emissions within 30-1000MHz were found more than 20dB below limit line.								
Frequency (MHz)	EIRP (dBm)	Limit (dBm)	Over Limit (dB)	SPA Reading (dBm)	S.G. Power (dBm)	TX Cable loss (dB)	TX Antenna Gain (dBi)	Polarization (H/V)	Result
3699	-47.02	-13	-34.02	-61.22	-51.62	3	7.60	H	Pass
5553	-42.31	-13	-29.31	-56.10	-48.57	3.84	10.10	H	Pass
7401	-42.85	-13	-29.85	-62.63	-50.35	4.43	11.93	H	Pass

Band :	GSM1900 for CH512					Temperature :	21~22°C		
Test Mode :	GSM Link (GMSK)					Relative Humidity :	41~42%		
Test Engineer :	Jack Wang					Polarization :	Vertical		
Remark :	Spurious emissions within 30-1000MHz were found more than 20dB below limit line.								
Frequency (MHz)	EIRP (dBm)	Limit (dBm)	Over Limit (dB)	SPA Reading (dBm)	S.G. Power (dBm)	TX Cable loss (dB)	TX Antenna Gain (dBi)	Polarization (H/V)	Result
3699	-50.62	-13	-37.62	-63.11	-55.22	3	7.60	V	Pass
5553	-39.42	-13	-26.42	-54.87	-45.68	3.84	10.10	V	Pass
7401	-45.10	-13	-32.10	-62.89	-52.60	4.43	11.93	V	Pass



Band :	GSM1900 for CH661					Temperature :	21~22°C		
Test Mode :	GSM Link (GMSK)					Relative Humidity :	41~42%		
Test Engineer :	Jack Wang					Polarization :	Horizontal		
Remark :	Spurious emissions within 30-1000MHz were found more than 20dB below limit line.								
Frequency (MHz)	EIRP (dBm)	Limit (dBm)	Over Limit (dB)	SPA Reading (dBm)	S.G. Power (dBm)	TX Cable loss (dB)	TX Antenna Gain (dBi)	Polarization (H/V)	Result
3759	-48.84	-13	-35.84	-63.04	-53.44	3	7.60	H	Pass
5643	-43.61	-13	-30.61	-57.40	-49.87	3.84	10.10	H	Pass
7521	-45.05	-13	-32.05	-64.83	-52.55	4.43	11.93	H	Pass

Band :	GSM1900 for CH661					Temperature :	21~22°C		
Test Mode :	GSM Link (GMSK)					Relative Humidity :	41~42%		
Test Engineer :	Jack Wang					Polarization :	Vertical		
Remark :	Spurious emissions within 30-1000MHz were found more than 20dB below limit line.								
Frequency (MHz)	EIRP (dBm)	Limit (dBm)	Over Limit (dB)	SPA Reading (dBm)	S.G. Power (dBm)	TX Cable loss (dB)	TX Antenna Gain (dBi)	Polarization (H/V)	Result
3759	-52.52	-13	-39.52	-65.01	-57.12	3	7.60	V	Pass
5643	-42.20	-13	-29.20	-56.16	-48.46	3.84	10.10	V	Pass
7521	-46.88	-13	-33.88	-64.67	-54.38	4.43	11.93	V	Pass



Band :	GSM1900 for CH810					Temperature :	21~22°C		
Test Mode :	GSM Link (GMSK)					Relative Humidity :	41~42%		
Test Engineer :	Jack Wang					Polarization :	Horizontal		
Remark :	Spurious emissions within 30-1000MHz were found more than 20dB below limit line.								
Frequency (MHz)	EIRP (dBm)	Limit (dBm)	Over Limit (dB)	SPA Reading (dBm)	S.G. Power (dBm)	TX Cable loss (dB)	TX Antenna Gain (dBi)	Polarization (H/V)	Result
3819	-48.79	-13	-35.79	-62.99	-53.39	3	7.60	H	Pass
5730	-42.45	-13	-29.45	-56.24	-48.71	3.84	10.10	H	Pass
7638	-42.79	-13	-29.79	-62.57	-50.29	4.43	11.93	H	Pass

Band :	GSM1900 for CH810					Temperature :	21~22°C		
Test Mode :	GSM Link (GMSK)					Relative Humidity :	41~42%		
Test Engineer :	Jack Wang					Polarization :	Vertical		
Remark :	Spurious emissions within 30-1000MHz were found more than 20dB below limit line.								
Frequency (MHz)	EIRP (dBm)	Limit (dBm)	Over Limit (dB)	SPA Reading (dBm)	S.G. Power (dBm)	TX Cable loss (dB)	TX Antenna Gain (dBi)	Polarization (H/V)	Result
3819	-51.65	-13	-38.65	-64.14	-56.25	3	7.60	V	Pass
5730	-39.91	-13	-26.91	-55.14	-46.17	3.84	10.10	V	Pass
7638	-45.69	-13	-32.69	-63.48	-53.19	4.43	11.93	V	Pass



Band :	GSM1900 for CH512					Temperature :	21~22°C		
Test Mode :	EDGE class 8 Link (8PSK)					Relative Humidity :	41~42%		
Test Engineer :	Jack Wang					Polarization :	Horizontal		
Remark :	Spurious emissions within 30-1000MHz were found more than 20dB below limit line.								
Frequency (MHz)	EIRP (dBm)	Limit (dBm)	Over Limit (dB)	SPA Reading (dBm)	S.G. Power (dBm)	TX Cable loss (dB)	TX Antenna Gain (dBi)	Polarization (H/V)	Result
3699	-51.21	-13	-38.21	-65.41	-55.81	3	7.60	H	Pass
5553	-44.99	-13	-31.99	-58.78	-51.25	3.84	10.10	H	Pass
7401	-43.80	-13	-30.80	-63.58	-51.30	4.43	11.93	H	Pass

Band :	GSM1900 for CH512					Temperature :	21~22°C		
Test Mode :	EDGE class 8 Link (8PSK)					Relative Humidity :	41~42%		
Test Engineer :	Jack Wang					Polarization :	Vertical		
Remark :	Spurious emissions within 30-1000MHz were found more than 20dB below limit line.								
Frequency (MHz)	EIRP (dBm)	Limit (dBm)	Over Limit (dB)	SPA Reading (dBm)	S.G. Power (dBm)	TX Cable loss (dB)	TX Antenna Gain (dBi)	Polarization (H/V)	Result
3699	-54.34	-13	-41.34	-66.83	-58.94	3	7.60	V	Pass
5553	-47.53	-13	-34.53	-59.94	-53.79	3.84	10.10	V	Pass
7401	-45.96	-13	-32.96	-63.75	-53.46	4.43	11.93	V	Pass



Band :	GSM1900 for CH661	Temperature :	21~22°C						
Test Mode :	EDGE class 8 Link (8PSK)	Relative Humidity :	41~42%						
Test Engineer :	Jack Wang	Polarization :	Horizontal						
Remark :	Spurious emissions within 30-1000MHz were found more than 20dB below limit line.								
Frequency (MHz)	EIRP (dBm)	Limit (dBm)	Over Limit (dB)	SPA Reading (dBm)	S.G. Power (dBm)	TX Cable loss (dB)	TX Antenna Gain (dBi)	Polarization (H/V)	Result
3759	-52.37	-13	-39.37	-66.57	-56.97	3	7.60	H	Pass
5643	-44.75	-13	-31.75	-58.54	-51.01	3.84	10.10	H	Pass
7521	-44.33	-13	-31.33	-64.11	-51.83	4.43	11.93	H	Pass

Band :	GSM1900 for CH661	Temperature :	21~22°C						
Test Mode :	EDGE class 8 Link (8PSK)	Relative Humidity :	41~42%						
Test Engineer :	Jack Wang	Polarization :	Vertical						
Remark :	Spurious emissions within 30-1000MHz were found more than 20dB below limit line.								
Frequency (MHz)	EIRP (dBm)	Limit (dBm)	Over Limit (dB)	SPA Reading (dBm)	S.G. Power (dBm)	TX Cable loss (dB)	TX Antenna Gain (dBi)	Polarization (H/V)	Result
3760	-54.09	-13	-41.09	-66.58	-58.69	3	7.60	V	Pass
5643	-47.35	-13	-34.35	-59.76	-53.61	3.84	10.10	V	Pass
7521	-46.26	-13	-33.26	-64.05	-53.76	4.43	11.93	V	Pass



Band :	GSM1900 for CH810					Temperature :	21~22°C		
Test Mode :	EDGE class 8 Link (8PSK)					Relative Humidity :	41~42%		
Test Engineer :	Jack Wang					Polarization :	Horizontal		
Remark :	Spurious emissions within 30-1000MHz were found more than 20dB below limit line.								
Frequency (MHz)	EIRP (dBm)	Limit (dBm)	Over Limit (dB)	SPA Reading (dBm)	S.G. Power (dBm)	TX Cable loss (dB)	TX Antenna Gain (dBi)	Polarization (H/V)	Result
3819	-52.26	-13	-39.26	-66.46	-56.86	3	7.60	H	Pass
5730	-44.95	-13	-31.95	-58.74	-51.21	3.84	10.10	H	Pass
7638	-44.04	-13	-31.04	-63.82	-51.54	4.43	11.93	H	Pass

Band :	GSM1900 for CH810					Temperature :	21~22°C		
Test Mode :	EDGE class 8 Link (8PSK)					Relative Humidity :	41~42%		
Test Engineer :	Jack Wang					Polarization :	Vertical		
Remark :	Spurious emissions within 30-1000MHz were found more than 20dB below limit line.								
Frequency (MHz)	EIRP (dBm)	Limit (dBm)	Over Limit (dB)	SPA Reading (dBm)	S.G. Power (dBm)	TX Cable loss (dB)	TX Antenna Gain (dBi)	Polarization (H/V)	Result
3819	-54.44	-13	-41.44	-66.93	-59.04	3	7.60	V	Pass
5730	-47.35	-13	-34.35	-59.76	-53.61	3.84	10.10	V	Pass
7638	-43.99	-13	-30.99	-61.78	-51.49	4.43	11.93	V	Pass



Band :	WCDMA Band V for CH4132					Temperature :	21~22°C		
Test Mode :	RMC 12.2Kbps Link (QPSK)					Relative Humidity :	41~42%		
Test Engineer :	Jack Wang					Polarization :	Horizontal		
Remark :	Spurious emissions within 30-1000MHz were found more than 20dB below limit line.								
Frequency (MHz)	ERP (dBm)	Limit (dBm)	Over Limit (dB)	SPA Reading (dBm)	S.G. Power (dBm)	TX Cable loss (dB)	TX Antenna Gain (dBi)	Polarization (H/V)	Result
1652	-55.77	-13	-42.77	-57.95	-57.66	1.86	5.90	H	Pass
2480	-54.82	-13	-41.82	-63.85	-57.16	2.31	6.80	H	Pass
3306	-53.12	-13	-40.12	-65.75	-55.52	2.85	7.40	H	Pass

Band :	WCDMA Band V for CH4132					Temperature :	21~22°C		
Test Mode :	RMC 12.2Kbps Link (QPSK)					Relative Humidity :	41~42%		
Test Engineer :	Jack Wang					Polarization :	Vertical		
Remark :	Spurious emissions within 30-1000MHz were found more than 20dB below limit line.								
Frequency (MHz)	ERP (dBm)	Limit (dBm)	Over Limit (dB)	SPA Reading (dBm)	S.G. Power (dBm)	TX Cable loss (dB)	TX Antenna Gain (dBi)	Polarization (H/V)	Result
1652	-60.63	-13	-47.63	-59.49	-62.52	1.86	5.90	V	Pass
2480	-53.72	-13	-40.72	-64.69	-56.06	2.31	6.80	V	Pass
3306	-51.75	-13	-38.75	-65.73	-54.15	2.85	7.40	V	Pass



Band :	WCDMA Band V for CH4182	Temperature :	21~22°C						
Test Mode :	RMC 12.2Kbps Link (QPSK)	Relative Humidity :	41~42%						
Test Engineer :	Jack Wang	Polarization :	Horizontal						
Remark :	Spurious emissions within 30-1000MHz were found more than 20dB below limit line.								
Frequency (MHz)	ERP (dBm)	Limit (dBm)	Over Limit (dB)	SPA Reading (dBm)	S.G. Power (dBm)	TX Cable loss (dB)	TX Antenna Gain (dBi)	Polarization (H/V)	Result
1672	-56.84	-13	-43.84	-59.02	-58.73	1.86	5.90	H	Pass
2509	-54.62	-13	-41.62	-63.65	-56.96	2.31	6.80	H	Pass
3345	-52.29	-13	-39.29	-64.92	-54.69	2.85	7.40	H	Pass

Band :	WCDMA Band V for CH4182	Temperature :	21~22°C						
Test Mode :	RMC 12.2Kbps Link (QPSK)	Relative Humidity :	41~42%						
Test Engineer :	Jack Wang	Polarization :	Vertical						
Remark :	Spurious emissions within 30-1000MHz were found more than 20dB below limit line.								
Frequency (MHz)	ERP (dBm)	Limit (dBm)	Over Limit (dB)	SPA Reading (dBm)	S.G. Power (dBm)	TX Cable loss (dB)	TX Antenna Gain (dBi)	Polarization (H/V)	Result
1672	-59.83	-13	-46.83	-58.69	-61.72	1.86	5.90	V	Pass
2509	-53.13	-13	-40.13	-64.10	-55.47	2.31	6.80	V	Pass
3345	-53.07	-13	-40.07	-67.05	-55.47	2.85	7.40	V	Pass



Band :	WCDMA Band V for CH4233					Temperature :	21~22°C		
Test Mode :	RMC 12.2Kbps Link (QPSK)					Relative Humidity :	41~42%		
Test Engineer :	Jack Wang					Polarization :	Horizontal		
Remark :	Spurious emissions within 30-1000MHz were found more than 20dB below limit line.								
Frequency (MHz)	ERP (dBm)	Limit (dBm)	Over Limit (dB)	SPA Reading (dBm)	S.G. Power (dBm)	TX Cable loss (dB)	TX Antenna Gain (dB)	Polarization (H/V)	Result
1692	-57.27	-13	-44.27	-59.45	-59.16	1.86	5.90	H	Pass
2540	-55.35	-13	-42.35	-64.38	-57.69	2.31	6.80	H	Pass
3387	-53.36	-13	-40.36	-65.99	-55.76	2.85	7.40	H	Pass

Band :	WCDMA Band V for CH4233					Temperature :	21~22°C		
Test Mode :	RMC 12.2Kbps Link (QPSK)					Relative Humidity :	41~42%		
Test Engineer :	Jack Wang					Polarization :	Vertical		
Remark :	Spurious emissions within 30-1000MHz were found more than 20dB below limit line.								
Frequency (MHz)	ERP (dBm)	Limit (dBm)	Over Limit (dB)	SPA Reading (dBm)	S.G. Power (dBm)	TX Cable loss (dB)	TX Antenna Gain (dB)	Polarization (H/V)	Result
1692	-59.20	-13	-46.20	-58.06	-61.09	1.86	5.90	V	Pass
2540	-53.57	-13	-40.57	-64.54	-55.91	2.31	6.80	V	Pass
3387	-52.87	-13	-39.87	-66.85	-55.27	2.85	7.40	V	Pass



Band :	WCDMA Band IV for CH1312					Temperature :	21~22°C		
Test Mode :	RMC 12.2Kbps Link (QPSK)					Relative Humidity :	41~42%		
Test Engineer :	Jack Wang					Polarization :	Horizontal		
Remark :	Spurious emissions within 30-1000MHz were found more than 20dB below limit line.								
Frequency (MHz)	EIRP (dBm)	Limit (dBm)	Over Limit (dB)	SPA Reading (dBm)	S.G. Power (dBm)	TX Cable loss (dB)	TX Antenna Gain (dBi)	Polarization (H/V)	Result
3426	-52.80	-13	-39.80	-66.93	-57.17	3.12	7.49	H	Pass
5137.2	-46.64	-13	-33.64	-59.79	-52.44	3.65	9.45	H	Pass
6849	-44.29	-13	-31.29	-61.15	-51.49	4.15	11.35	H	Pass

Band :	WCDMA Band IV for CH1312					Temperature :	21~22°C		
Test Mode :	RMC 12.2Kbps Link (QPSK)					Relative Humidity :	41~42%		
Test Engineer :	Jack Wang					Polarization :	Vertical		
Remark :	Spurious emissions within 30-1000MHz were found more than 20dB below limit line.								
Frequency (MHz)	EIRP (dBm)	Limit (dBm)	Over Limit (dB)	SPA Reading (dBm)	S.G. Power (dBm)	TX Cable loss (dB)	TX Antenna Gain (dBi)	Polarization (H/V)	Result
3426	-54.06	-13	-41.06	-66.88	-58.43	3.12	7.49	V	Pass
5142	-46.31	-13	-33.31	-60.32	-52.11	3.65	9.45	V	Pass
6849	-47.04	-13	-34.04	-62.29	-54.24	4.15	11.35	V	Pass



Band :	WCDMA Band IV for CH1413					Temperature :	21~22°C		
Test Mode :	RMC 12.2Kbps Link (QPSK)					Relative Humidity :	41~42%		
Test Engineer :	Jack Wang					Polarization :	Horizontal		
Remark :	Spurious emissions within 30-1000MHz were found more than 20dB below limit line.								
Frequency (MHz)	EIRP (dBm)	Limit (dBm)	Over Limit (dB)	SPA Reading (dBm)	S.G. Power (dBm)	TX Cable loss (dB)	TX Antenna Gain (dBi)	Polarization (H/V)	Result
3465	-53.01	-13	-40.01	-67.14	-57.38	3.12	7.49	H	Pass
5197.8	-45.61	-13	-32.61	-58.76	-51.41	3.65	9.45	H	Pass
6930	-45.39	-13	-32.39	-62.25	-52.59	4.15	11.35	H	Pass

Band :	WCDMA Band IV for CH1413					Temperature :	21~22°C		
Test Mode :	RMC 12.2Kbps Link (QPSK)					Relative Humidity :	41~42%		
Test Engineer :	Jack Wang					Polarization :	Vertical		
Remark :	Spurious emissions within 30-1000MHz were found more than 20dB below limit line.								
Frequency (MHz)	EIRP (dBm)	Limit (dBm)	Over Limit (dB)	SPA Reading (dBm)	S.G. Power (dBm)	TX Cable loss (dB)	TX Antenna Gain (dBi)	Polarization (H/V)	Result
3465	-54.56	-13	-41.56	-67.38	-58.93	3.12	7.49	V	Pass
5197.8	-46.09	-13	-33.09	-60.1	-51.89	3.65	9.45	V	Pass
6930	-47.29	-13	-34.29	-62.54	-54.49	4.15	11.35	V	Pass



Band :	WCDMA Band IV for CH1513					Temperature :	21~22°C		
Test Mode :	RMC 12.2Kbps Link (QPSK)					Relative Humidity :	41~42%		
Test Engineer :	Jack Wang					Polarization :	Horizontal		
Remark :	Spurious emissions within 30-1000MHz were found more than 20dB below limit line.								
Frequency (MHz)	EIRP (dBm)	Limit (dBm)	Over Limit (dB)	SPA Reading (dBm)	S.G. Power (dBm)	TX Cable loss (dB)	TX Antenna Gain (dBi)	Polarization (H/V)	Result
3505.2	-52.92	-13	-39.92	-67.05	-57.29	3.12	7.49	H	Pass
5256	-43.78	-13	-30.78	-56.93	-49.58	3.65	9.45	H	Pass
7011	-44.37	-13	-31.37	-61.23	-51.57	4.15	11.35	H	Pass

Band :	WCDMA Band IV for CH1513					Temperature :	21~22°C		
Test Mode :	RMC 12.2Kbps Link (QPSK)					Relative Humidity :	41~42%		
Test Engineer :	Jack Wang					Polarization :	Vertical		
Remark :	Spurious emissions within 30-1000MHz were found more than 20dB below limit line.								
Frequency (MHz)	EIRP (dBm)	Limit (dBm)	Over Limit (dB)	SPA Reading (dBm)	S.G. Power (dBm)	TX Cable loss (dB)	TX Antenna Gain (dBi)	Polarization (H/V)	Result
3504	-54.47	-13	-41.47	-67.29	-58.84	3.12	7.49	V	Pass
5257.5	-42.78	-13	-29.78	-56.79	-48.58	3.65	9.45	V	Pass
7011	-45.82	-13	-32.82	-61.07	-53.02	4.15	11.35	V	Pass



Band :	WCDMA Band II for CH9262	Temperature :	21~22°C						
Test Mode :	RMC 12.2Kbps Link (QPSK)	Relative Humidity :	41~42%						
Test Engineer :	Jack Wang	Polarization :	Horizontal						
Remark :	Spurious emissions within 30-1000MHz were found more than 20dB below limit line.								
Frequency (MHz)	EIRP (dBm)	Limit (dBm)	Over Limit (dB)	SPA Reading (dBm)	S.G. Power (dBm)	TX Cable loss (dB)	TX Antenna Gain (dBi)	Polarization (H/V)	Result
3705	-52.41	-13	-39.41	-66.61	-57.01	3	7.60	H	Pass
5556	-36.03	-13	-23.03	-53.00	-42.29	3.84	10.10	H	Pass
7410	-44.27	-13	-31.27	-64.05	-51.77	4.43	11.93	H	Pass

Band :	WCDMA Band II for CH9262	Temperature :	21~22°C						
Test Mode :	RMC 12.2Kbps Link (QPSK)	Relative Humidity :	41~42%						
Test Engineer :	Jack Wang	Polarization :	Vertical						
Remark :	Spurious emissions within 30-1000MHz were found more than 20dB below limit line.								
Frequency (MHz)	EIRP (dBm)	Limit (dBm)	Over Limit (dB)	SPA Reading (dBm)	S.G. Power (dBm)	TX Cable loss (dB)	TX Antenna Gain (dBi)	Polarization (H/V)	Result
3705	-53.15	-13	-40.15	-65.64	-57.75	3	7.60	V	Pass
5556	-39.58	-13	-26.58	-54.96	-45.84	3.84	10.10	V	Pass
7410	-45.56	-13	-32.56	-63.35	-53.06	4.43	11.93	V	Pass



Band :	WCDMA Band II for CH9400	Temperature :	21~22°C						
Test Mode :	RMC 12.2Kbps Link (QPSK)	Relative Humidity :	41~42%						
Test Engineer :	Jack Wang	Polarization :	Horizontal						
Remark :	Spurious emissions within 30-1000MHz were found more than 20dB below limit line.								
Frequency (MHz)	EIRP (dBm)	Limit (dBm)	Over Limit (dB)	SPA Reading (dBm)	S.G. Power (dBm)	TX Cable loss (dB)	TX Antenna Gain (dBi)	Polarization (H/V)	Result
3759	-52.68	-13	-39.68	-66.88	-57.28	3	7.60	H	Pass
5646	-37.23	-13	-24.23	-53.76	-43.49	3.84	10.10	H	Pass
7521	-43.69	-13	-30.69	-63.47	-51.19	4.43	11.93	H	Pass

Band :	WCDMA Band II for CH9400	Temperature :	21~22°C						
Test Mode :	RMC 12.2Kbps Link (QPSK)	Relative Humidity :	41~42%						
Test Engineer :	Jack Wang	Polarization :	Vertical						
Remark :	Spurious emissions within 30-1000MHz were found more than 20dB below limit line.								
Frequency (MHz)	EIRP (dBm)	Limit (dBm)	Over Limit (dB)	SPA Reading (dBm)	S.G. Power (dBm)	TX Cable loss (dB)	TX Antenna Gain (dBi)	Polarization (H/V)	Result
3759	-54.25	-13	-41.25	-66.74	-58.85	3	7.60	V	Pass
5646	-44.73	-13	-31.73	-57.14	-50.99	3.84	10.10	V	Pass
7521	-46.24	-13	-33.24	-64.03	-53.74	4.43	11.93	V	Pass



Band :	WCDMA Band II for CH9538	Temperature :	21~22°C						
Test Mode :	RMC 12.2Kbps Link (QPSK)	Relative Humidity :	41~42%						
Test Engineer :	Jack Wang	Polarization :	Horizontal						
Remark :	Spurious emissions within 30-1000MHz were found more than 20dB below limit line.								
Frequency (MHz)	EIRP (dBm)	Limit (dBm)	Over Limit (dB)	SPA Reading (dBm)	S.G. Power (dBm)	TX Cable loss (dB)	TX Antenna Gain (dB)	Polarization (H/V)	Result
3816	-51.82	-13	-38.82	-66.02	-56.42	3	7.60	H	Pass
5727	-36.83	-13	-23.83	-53.54	-43.09	3.84	10.10	H	Pass
7629	-42.16	-13	-29.16	-61.94	-49.66	4.43	11.93	H	Pass

Band :	WCDMA Band II for CH9538	Temperature :	21~22°C						
Test Mode :	RMC 12.2Kbps Link (QPSK)	Relative Humidity :	41~42%						
Test Engineer :	Jack Wang	Polarization :	Vertical						
Remark :	Spurious emissions within 30-1000MHz were found more than 20dB below limit line.								
Frequency (MHz)	EIRP (dBm)	Limit (dBm)	Over Limit (dB)	SPA Reading (dBm)	S.G. Power (dBm)	TX Cable loss (dB)	TX Antenna Gain (dB)	Polarization (H/V)	Result
3816	-52.65	-13	-39.65	-65.14	-57.25	3	7.60	V	Pass
5727	-41.37	-13	-28.37	-55.96	-47.63	3.84	10.10	V	Pass
7629	-43.77	-13	-30.77	-61.56	-51.27	4.43	11.93	V	Pass

3.8 Frequency Stability Measurement

3.8.1 Description of Frequency Stability Measurement

The frequency stability shall be measured by variation of ambient temperature and variation of primary supply voltage to ensure that the fundamental emission stays within the authorized frequency block. The frequency stability of the transmitter shall be maintained within $\pm 0.00025\%$ ($\pm 2.5\text{ppm}$) of the center frequency.

3.8.2 Measuring Instruments

The measuring equipment is listed in the section 4 of this test report.

3.8.3 Test Procedures for Temperature Variation

1. The testing follows FCC KDB 971168 v02r02 Section 9.0.
2. The EUT was set up in the thermal chamber and connected with the system simulator.
3. With power OFF, the temperature was decreased to -30°C and the EUT was stabilized before testing. Power was applied and the maximum change in frequency was recorded within one minute.
4. With power OFF, the temperature was raised in 10°C steps up to 50°C . The EUT was stabilized at each step for at least half an hour. Power was applied and the maximum frequency change was recorded within one minute.

3.8.4 Test Procedures for Voltage Variation

1. The testing follows FCC KDB 971168 v02r02 Section 9.0.
2. The EUT was placed in a temperature chamber at $25\pm 5^{\circ}\text{C}$ and connected with the system simulator.
3. The power supply voltage to the EUT was varied from BEP to 115% of the nominal value measured at the input to the EUT.
4. The variation in frequency was measured for the worst case.

3.8.5 Test Setup

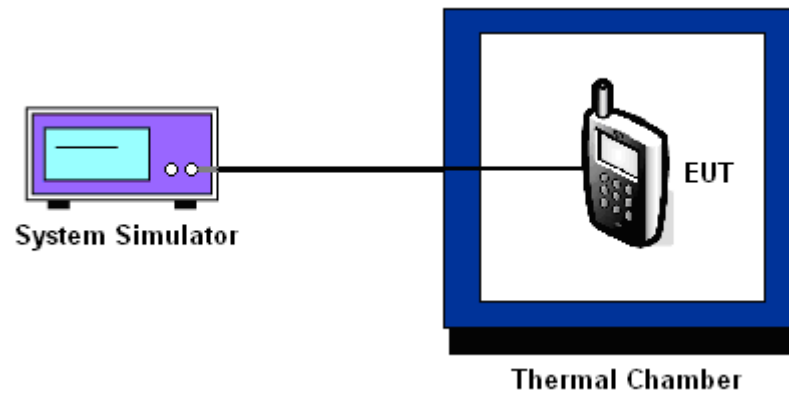



3.8.6 Test Result of Temperature Variation

Band :	GSM 850	Channel :	189
Limit (ppm) :	2.5	Frequency :	836.4 MHz

Temperature (°C)	GSM	EDGE class 8	Result
	Deviation (ppm)	Deviation (ppm)	
50	0.0096	0.0132	PASS
40	0.0526	0.0108	
30	0.0012	0.0514	
20(Ref.)	0.0000	0.0000	
10	0.0550	0.0442	
0	0.0024	0.0036	
-10	0.0430	0.0418	
-20	0.0072	0.0024	
-30	0.0478	0.0478	

Band :	GSM 1900	Channel :	661
Limit (ppm) :	within authorized band	Frequency :	1880.0 MHz

Temperature (°C)	GSM	EDGE class 8	Result
	Deviation (ppm)	Deviation (ppm)	
50	0.0234	0.0213	PASS
40	0.0090	0.0112	
30	0.0016	0.0011	
20(Ref.)	0.0000	0.0000	
10	0.0048	0.0053	
0	0.0101	0.0138	
-10	0.0117	0.0112	
-20	0.0181	0.0154	
-30	0.0160	0.0128	

Note: The frequency fundamental emissions stay within the authorized frequency block based on the frequency deviation measured is small.



Band :	WCDMA Band V	Channel :	4182
Limit (ppm) :	2.5	Frequency :	836.4 MHz

Temperature (°C)	RMC 12.2Kbps	Result
	Deviation (ppm)	
50	0.0036	PASS
40	0.0466	
30	0.0060	
20(Ref.)	0.0000	
10	0.0430	
0	0.0084	
-10	0.0383	
-20	0.0143	
-30	0.0454	

Band :	WCDMA Band IV	Channel :	1413
Limit (ppm) :	within authorized band	Frequency :	1732.6 MHz

Temperature (°C)	RMC 12.2Kbps	Result
	Deviation (ppm)	
50	0.0341	PASS
40	0.0387	
30	0.0040	
20(Ref.)	0.0000	
10	0.0035	
0	0.0167	
-10	0.0214	
-20	0.0006	
-30	0.0312	

Note: The frequency fundamental emissions stay within the authorized frequency block based on the frequency deviation measured is small.



Band :	WCDMA Band II	Channel :	9400
Limit (ppm) :	within authorized band	Frequency :	1880.0 MHz

Temperature (°C)	RMC 12.2Kbps	Result
	Deviation (ppm)	
50	0.0271	PASS
40	0.0106	
30	0.0043	
20(Ref.)	0.0000	
10	0.0069	
0	0.0213	
-10	0.0176	
-20	0.0048	
-30	0.0223	

Note: The frequency fundamental emissions stay within the authorized frequency block based on the frequency deviation measured is small.



3.8.7 Test Result of Voltage Variation

Band & Channel	Mode	Voltage (Volt)	Deviation (ppm)	Limit (ppm)	Result
GSM 850 CH189	GSM	3.80	0.0060	2.5	PASS
		BEP	0.0371		
		4.35	0.0036		
	EDGE class 8	3.80	0.0048		
		BEP	0.0323		
		4.35	0.0012		
GSM 1900 CH661	GSM	3.80	0.0176	(Note 3.)	
		BEP	0.0106		
		4.35	0.0207		
	EDGE class 8	3.80	0.0085		
		BEP	0.0122		
		4.35	0.0122		
WCDMA Band V CH4182	RMC 12.2Kbps	3.80	0.0155	2.5	
		BEP	0.0323		
		4.35	0.0096		
WCDMA Band IV CH1413	RMC 12.2Kbps	3.80	0.0190	(Note 3.)	
		BEP	0.0173		
		4.35	0.0156		
WCDMA Band II CH9400	RMC 12.2Kbps	3.80	0.0053	(Note 3.)	
		BEP	0.0149		
		4.35	0.0154		

Note:

1. Normal Voltage = 3.80V.
2. Battery End Point (BEP) = 3.40 V.
3. The frequency fundamental emissions stay within the authorized frequency block based on the frequency deviation measured is small.



4 List of Measuring Equipment

Instrument	Manufacturer	Model No.	Serial No.	Characteristics	Calibration Date	Test Date	Due Date	Remark
Spectrum Analyzer	R&S	FSP40	100319	9kHz~40GHz	Oct. 28, 2014	Aug. 17, 2015~ Sep. 30, 2015	Oct. 27, 2015	Conducted (TH01-KS)
Spectrum Analyzer	R&S	FSV30	101338	9kHz~30GHz	May 04, 2015	Aug. 17, 2015~ Sep. 30, 2015	May 03, 2016	Conducted (TH01-KS)
Thermal Chamber	Ten Billion	TTC-B3S	TBN-960502	-40~+150°C	Oct. 25, 2014	Aug. 17, 2015~ Sep. 30, 2015	Oct. 24, 2015	Conducted (TH01-KS)
EMI Test Receiver	R&S	ESR7	101403	9kHz~7GHz;Max 30dBm	Sep. 10, 2015	Sep. 30, 2015	Sep. 09, 2016	Radiation (03CH02-KS)
Spectrum Analyzer	R&S	FSV40	101040	10kHz~40GHz;Ma x 30dBm	Sep. 10, 2015	Sep. 30, 2015	Sep. 09, 2016	Radiation (03CH02-KS)
Bilog Antenna	TeseQ	CBL6112D	37879	30MHz-2GHz	Sep. 12, 2015	Sep. 30, 2015	Sep. 11, 2016	Radiation (03CH02-KS)
Double Ridge Horn Antenna	ETS-Lindgren	3117	75957	1GHz~18GHz	Nov. 08, 2014	Sep. 30, 2015	Nov. 07, 2015	Radiation (03CH02-KS)
Active Horn Antenna	com-power	AHA-118	701030	1GHz~18GHz	Nov. 08, 2014	Sep. 30, 2015	Nov. 07, 2015	Radiation (03CH02-KS)
SHF-EHF Horn	Schwarzbeck	BBHA 9170	BBHA170249	15GHz ~40GHz	Mar. 03, 2015	Sep. 30, 2015	Mar. 02, 2016	Radiation (03CH02-KS)
Amplifier	com-power	PA-103A	161069	1kHz ~1000MHz / 32 dB	May 04, 2015	Sep. 30, 2015	May 03, 2016	Radiation (03CH02-KS)
Amplifier	Agilent	8449B	3008A02384	1-26.5GHz Gain 30dB	Oct. 28, 2014	Sep. 30, 2015	Oct. 27, 2015	Radiation (03CH02-KS)
AC Power Source	Chroma	61601	61601000247 3	N/A	NCR	Sep. 30, 2015	NCR	Radiation (03CH02-KS)
Turn Table	MF	MF7802	N/A	0~360 degree	NCR	Sep. 30, 2015	NCR	Radiation (03CH02-KS)
Antenna Mast	MF	MF7802	N/A	1 m~4 m	NCR	Sep. 30, 2015	NCR	Radiation (03CH02-KS)



5 Uncertainty of Evaluation

Uncertainty of Radiated Emission Measurement (30 MHz ~ 1000 MHz)

Measuring Uncertainty for a Level of Confidence of 95% ($U = 2Uc(y)$)	5.1 dB
---	--------