



FCC RF Test Report

APPLICANT : Acer Incorporated
EQUIPMENT : Smart HandHeld
BRAND NAME : Acer
MODEL NAME : T01, TM01
MARKETING NAME : Liquid Z330, Liquid M330
FCC ID : HLZDMZ330
STANDARD : FCC Part 15 Subpart C §15.247
CLASSIFICATION : (DTS) Digital Transmission System

The product was received on Jul. 14, 2015 and testing was completed on Aug. 16, 2015. We, SPORTON INTERNATIONAL (KUNSHAN) INC., would like to declare that the tested sample has been evaluated in accordance with the test procedures and has been in compliance with the applicable technical standards.

The test results in this report apply exclusively to the tested model / sample. Without written approval of SPORTON INTERNATIONAL (KUNSHAN) INC., the test report shall not be reproduced except in full.

Reviewed by: Joseph Lin / Supervisor

Approved by: Jones Tsai / Manager



SPORTON INTERNATIONAL (KUNSHAN) INC.
No. 3-2, PingXiang Road, Kunshan, Jiangsu Province, P. R. China



TABLE OF CONTENTS

REVISION HISTORY..... 3

SUMMARY OF TEST RESULT 4

1 GENERAL DESCRIPTION 5

 1.1 Applicant 5

 1.2 Manufacturer 5

 1.3 Product Feature of Equipment Under Test 5

 1.4 Product Specification subjective to this standard 6

 1.5 Modification of EUT 7

 1.6 Testing Location 7

 1.7 Applicable Standards 7

2 TEST CONFIGURATION OF EQUIPMENT UNDER TEST 8

 2.1 Carrier Frequency Channel 8

 2.2 Pre-Scanned RF Power 9

 2.3 Test Mode 10

 2.4 Connection Diagram of Test System 11

 2.5 Support Unit used in test configuration and system 12

 2.6 EUT Operation Test Setup 12

 2.7 Measurement Results Explanation Example 12

3 TEST RESULT 13

 3.1 6dB and 99% Bandwidth Measurement 13

 3.2 Output Power Measurement 15

 3.3 Power Spectral Density Measurement 17

 3.4 Conducted Band Edges and Spurious Emission Measurement 19

 3.5 Radiated Band Edges and Spurious Emission Measurement 29

 3.6 AC Conducted Emission Measurement 33

 3.7 Antenna Requirements 37

4 LIST OF MEASURING EQUIPMENT 38

5 UNCERTAINTY OF EVALUATION 39

APPENDIX A. CONDUCTED TEST RESULTS

APPENDIX B. RADIATED TEST RESULTS

APPENDIX C. SETUP PHOTOGRAPHS



REVISION HISTORY

| REPORT NO. | VERSION | DESCRIPTION | ISSUED DATE |
|------------|---------|-------------------------|---------------|
| FR571424C | Rev. 01 | Initial issue of report | Oct. 13, 2015 |
| | | | |
| | | | |
| | | | |
| | | | |
| | | | |
| | | | |
| | | | |
| | | | |
| | | | |
| | | | |
| | | | |
| | | | |
| | | | |
| | | | |
| | | | |
| | | | |
| | | | |
| | | | |
| | | | |

**SUMMARY OF TEST RESULT**

| Report Section | FCC Rule | IC Rule | Description | Limit | Result | Remark |
|----------------|-----------------------|--------------------|---|--------------------------------|--------|--|
| 3.1 | 15.247(a)(2) | RSS-247 5.2(1) | 6dB Bandwidth | $\geq 0.5\text{MHz}$ | Pass | - |
| 3.1 | - | RSS-Gen 6.6 | 99% Bandwidth | - | Pass | - |
| 3.2 | 15.247(b) | RSS-247 A5.4(4) | Power Output Measurement | $\leq 30\text{dBm}$ | Pass | - |
| 3.3 | 15.247(e) | RSS-247 5.2(2) | Power Spectral Density | $\leq 8\text{dBm}/3\text{kHz}$ | Pass | - |
| 3.4 | 15.247(d) | RSS-247 5.5 | Conducted Band Edges | $\leq 20\text{dBc}$ | Pass | - |
| | | | Conducted Spurious Emission | | Pass | - |
| 3.5 | 15.247(d) | RSS-247 5.5 | Radiated Band Edges and Radiated Spurious Emission | 15.209(a) & 15.247(d) | Pass | Under limit 10.74 dB at 2483.880 MHz |
| 3.6 | 15.207 | RSS-GEN 8.8 | AC Conducted Emission | 15.207(a) | Pass | Under limit 16.14 dB at 1.160 MHz |
| 3.7 | 15.203 & 15.247(b) | N/A | Antenna Requirement | N/A | Pass | - |



1 General Description

1.1 Applicant

Acer Incorporated

8F., No. 88, Sec. 1, Xintai 5th Rd., Xizhi Dist., New Taipei City 22181, Taiwan (R.O.C)

1.2 Manufacturer

Shanghai HuaQin Telecom Technology CO., LTD

Building 1, No.399, Keyuan Road, High-tech Park PudongZhangjiang, Shanghai, China

1.3 Product Feature of Equipment Under Test

| Product Feature | |
|--|---|
| Equipment | Smart HandHeld |
| Brand Name | Acer |
| Model Name | T01, TM01 |
| Marketing Name | Liquid Z330, Liquid M330 |
| FCC ID | HLZDMZ330 |
| EUT supports Radios application | GSM/GPRS/EGPRS/WCDMA/HSPA/HSPA+(Downlink Only)/DC-HSDPA/LTE WLAN2.4GHz 802.11b/g/n HT20 Bluetooth v3.0+EDR Bluetooth v4.0 LE |
| IMEI Code | Conducted: 352921070004206/352921070006680 Conduction: 352921070005955/352921070008439 Radiation: 352921070004123/352921070006607 |
| EUT Stage | Identical Prototype |

Remark: The above EUT's information was declared by manufacturer. Please refer to the specifications or user's manual for more detailed description.



1.4 Product Specification subjective to this standard

| Product Specification subjective to this standard | |
|---|---|
| Tx/Rx Channel Frequency Range | 802.11b/g/n : 2412 MHz ~ 2462 MHz |
| Maximum (Peak) Output Power to Antenna | 802.11b : 17.48 dBm (0.0560 W) 802.11g : 21.59 dBm (0.1442 W) 802.11n HT20 : 20.17 dBm (0.1040 W) |
| 99% Occupied Bandwidth | 802.11b : 13.44MHz 802.11g : 19.08MHz 802.11n HT20 : 19.23MHz |
| Antenna Type | IFA Antenna with gain 1.60 dBi |
| Type of Modulation | 802.11b : DSSS (DBPSK / DQPSK / CCK) 802.11g/n : OFDM (BPSK / QPSK / 16QAM / 64QAM) |



1.5 Modification of EUT

No modifications are made to the EUT during all test items.

1.6 Testing Location

| | | | | |
|---------------------------|---|-----------|---------|--------------------------------|
| Test Site | SPORTON INTERNATIONAL (KUNSHAN) INC. | | | |
| Test Site Location | No. 3-2, PingXiang Road, Kunshan, Jiangsu Province, P. R. China TEL: +86-0512-5790-0158 FAX: +86-0512-5790-0958 | | | |
| Test Site No. | Sporton Site No. | | | FCC/IC Registration No. |
| | TH01-KS | 03CH02-KS | CO01-KS | 418269/4086E |

Note: The test site complies with ANSI C63.4 2009 requirement.

1.7 Applicable Standards

According to the specifications of the manufacturer, the EUT must comply with the requirements of the following standards:

- FCC Part 15 Subpart C §15.247
- FCC KDB Publication No. 558074 D01 DTS Meas. Guidance v03r03
- ANSI C63.10-2013
- IC RSS-247 Issue 1
- IC RSS-Gen Issue 4

Remark:

1. All test items were verified and recorded according to the standards and without any deviation during the test.
2. FCC permits the use of the 1.5 meter table as an alternative in C63.10-2013 through inquiry tracking number 961829.
3. This EUT has also been tested and complied with the requirements of FCC Part 15, Subpart B, recorded in a separate test report.



2 Test Configuration of Equipment Under Test

The EUT has been associated with peripherals and configuration operated in a manner tended to maximize its emission characteristics in a typical application. Frequency range investigated: conducted emission (150 kHz to 30 MHz) and radiated emission (9 kHz to the 10th harmonic of the highest fundamental frequency or to 40 GHz, whichever is lower). For radiated measurement, pre-scanned in three orthogonal panels, X, Y, Z. The worst cases (Z plane) were recorded in this report.

The final configuration from all the combinations and the worst-case data rates were investigated by measuring the maximum power across all the data rates and modulation modes under section 2.2.

Based on the worst configuration found above, the RF power setting is set individually to meet FCC compliance limit for the final conducted and radiated tests shown in section 2.3.

2.1 Carrier Frequency Channel

| Frequency Band | Channel | Freq. (MHz) | Channel | Freq. (MHz) |
|-----------------|---------|-------------|---------|-------------|
| 2400-2483.5 MHz | 1 | 2412 | 7 | 2442 |
| | 2 | 2417 | 8 | 2447 |
| | 3 | 2422 | 9 | 2452 |
| | 4 | 2427 | 10 | 2457 |
| | 5 | 2432 | 11 | 2462 |
| | 6 | 2437 | - | - |



2.2 Pre-Scanned RF Power

Preliminary tests were performed in different data rate and data rate associated with the highest power were chosen for full test shown in the following tables.

| 2.4GHz 802.11b mode | | | | |
|---------------------|--------|--------|----------|---------|
| Data Rate (MHz) | 1M bps | 2M bps | 5.5M bps | 11M bps |
| Peak Power (dBm) | 17.48 | 17.26 | 17.36 | 17.45 |

| 2.4GHz 802.11g mode | | | | | | | | |
|---------------------|--------|--------|---------|---------|---------|---------|---------|---------|
| Data Rate (MHz) | 6M bps | 9M bps | 12M bps | 18M bps | 24M bps | 36M bps | 48M bps | 54M bps |
| Peak Power (dBm) | 21.59 | 21.26 | 21.46 | 21.27 | 21.34 | 21.55 | 21.45 | 21.32 |

| 2.4GHz 802.11n HT20 mode | | | | | | | | |
|--------------------------|-------|-------|-------|-------|-------|-------|-------|-------|
| Data Rate (MHz) | MCS0 | MCS1 | MCS2 | MCS3 | MCS4 | MCS5 | MCS6 | MCS7 |
| Peak Power (dBm) | 20.17 | 19.93 | 19.75 | 19.99 | 19.87 | 20.15 | 19.86 | 19.98 |



2.3 Test Mode

Final test mode of conducted test items and radiated spurious emissions are considering the modulation and worse data rates from the power table described in section 2.2.

<2.4GHz>

| Modulation | Data Rate |
|--------------|-----------|
| 802.11b | 1 Mbps |
| 802.11g | 6 Mbps |
| 802.11n HT20 | MCS0 |

| Test Cases | |
|-----------------------|---|
| AC Conducted Emission | Mode 1: GSM850 Idle + Bluetooth Link + WLAN Link + Earphone + USB Cable (Charging from Adapter) + SIM 1 |

2.4 Connection Diagram of Test System

<WLAN Tx Mode>

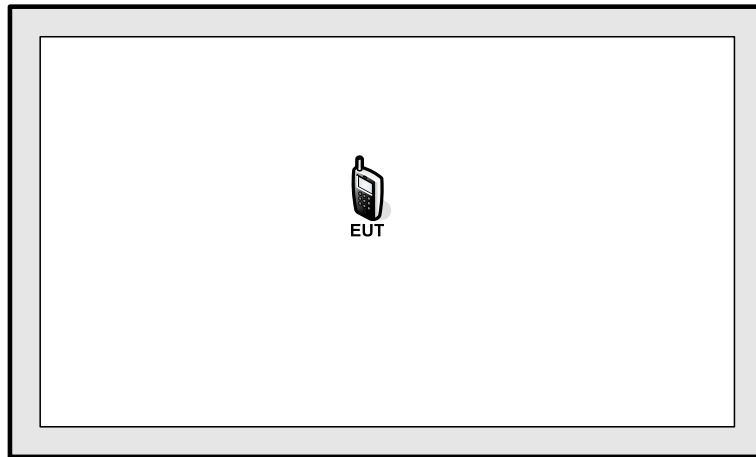

<AC Conducted Emission Mode>

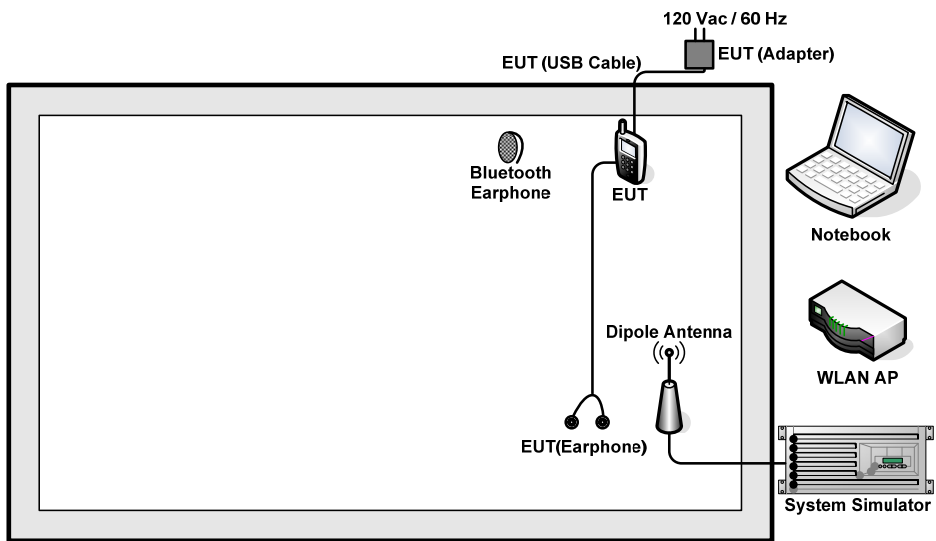

2.5 Support Unit used in test configuration and system

| Item | Equipment | Trade Name | Model Name | FCC ID | Data Cable | Power Cord |
|------|--------------------|------------|------------|----------------|------------|--|
| 1. | System Simulator | Anritsu | MT8820C | N/A | N/A | Unshielded, 1.8 m |
| 2. | WLAN AP | LINKSYS | WRT600N | Q87-WRT600NV11 | N/A | Unshielded, 1.8 m |
| 3. | Notebook | Lenovo | G480 | FCC DoC | N/A | AC I/P: Unshielded, 1.2 m DC O/P: Shielded, 1.8 m |
| 4. | Bluetooth Earphone | Nokia | BH-102 | PYAHS-107W | N/A | N/A |

2.6 EUT Operation Test Setup

For WLAN function, the engineering test program was provided and enabled to make EUT continuous transmit/receive.

For AC power line conducted emissions, the EUT was set to connect with the WLAN AP under large package sizes transmission.

2.7 Measurement Results Explanation Example

For all conducted test items:

The offset level is set in the spectrum analyzer to compensate the RF cable loss between EUT conducted output port and spectrum analyzer. With the offset compensation, the spectrum analyzer reading level is exactly the EUT RF output level.

Example:

The spectrum analyzer offset is derived from RF cable loss.

Offset = RF cable loss.

Following shows an offset computation example with cable loss 5.5 dB.

$$\begin{aligned} \text{Offset(dB)} &= \text{RF cable loss(dB)}. \\ &= 5.5 \text{ (dB)} \end{aligned}$$

3 Test Result

3.1 6dB and 99% Bandwidth Measurement

3.1.1 Limit of 6dB and 99% Bandwidth

The minimum 6 dB bandwidth shall be at least 500 kHz.

3.1.2 Measuring Instruments

The measuring equipment is listed in the section 4 of this test report.

3.1.3 Test Procedures

1. The testing follows FCC KDB Publication No. 558074 DTS D01 Meas. Guidance v03r03.
2. The RF output of EUT was connected to the spectrum analyzer by RF cable and attenuator. The path loss was compensated to the results for each measurement.
3. Set to the maximum power setting and enable the EUT transmit continuously.
4. Make the measurement with the spectrum analyzer's resolution bandwidth (RBW) = 100 kHz. Set the Video bandwidth (VBW) = 300 kHz. In order to make an accurate measurement. The 6 dB bandwidth must be greater than 500 kHz.
5. For 99% Bandwidth Measurement, the spectrum analyzer's resolution bandwidth (RBW) = 1MHz and set the Video bandwidth (VBW) = 3MHz.
6. Measure and record the results in the test report.

3.1.4 Test Setup

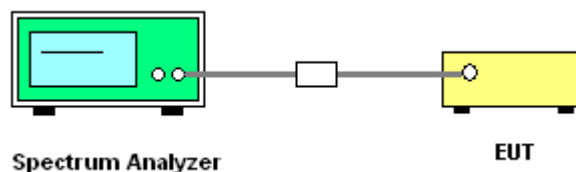



3.1.5 Test Result of 6dB and 99% Occupied Bandwidth

Please refer to Appendix A of this test report.

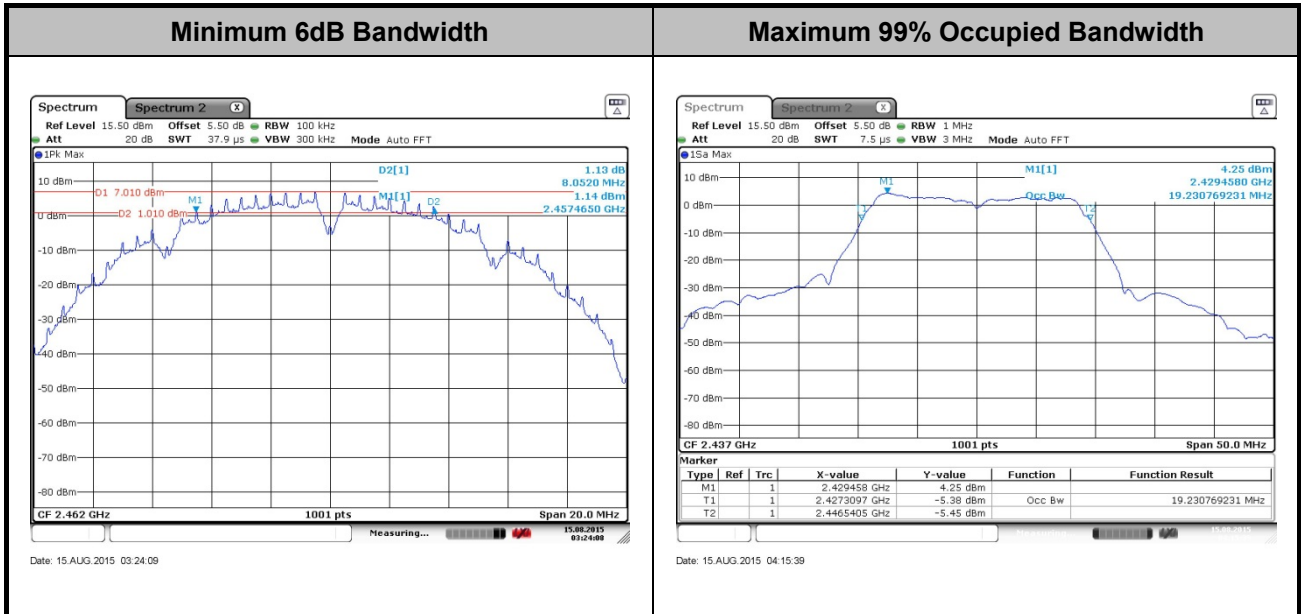

Note : The occupied channel bandwidth is maintained within the band of operation for all of the modulations.

3.2 Output Power Measurement

3.2.1 Limit of Output Power

For systems using digital modulation in the 2400-2483.5MHz, the limit for peak output power is 30dBm. If transmitting Antenna of directional gain greater than 6dBi are used the peak output power from the intentional radiator shall be reduced below the above stated value by the amount in dB that the directional gain of the Antenna exceeds 6 dBi. In case of point-to-point operation, the limit has to be reduced by 1dB for every 3dB that the directional gain of the Antenna exceeds 6dBi.

3.2.2 Measuring Instruments

The measuring equipment is listed in the section 4 of this test report.

3.2.3 Test Procedures

1. The testing follows the Measurement Procedure of FCC KDB No. 558074 DTS D01 Meas. Guidance v03r03 section 9.1.2 PKPM1 Peak power meter method.
2. The RF output of EUT was connected to the power meter by RF cable and attenuator. The path loss was compensated to the results for each measurement.
3. Set to the maximum power setting and enable the EUT transmit continuously.
4. Measure the conducted output power and record the results in the test report.

3.2.4 Test Setup

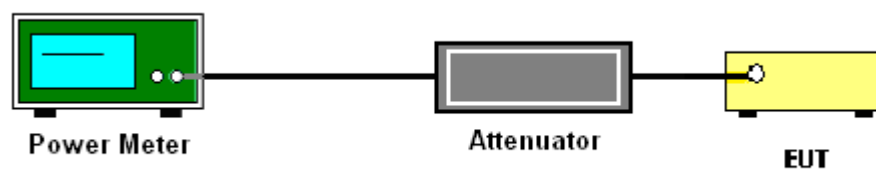



3.2.5 Test Result of Peak Output Power

Please refer to Appendix A of this test report.

3.2.6 Test Result of Average output Power (Reporting Only)

Please refer to Appendix A of this test report.

3.3 Power Spectral Density Measurement

3.3.1 Limit of Power Spectral Density

The peak power spectral density shall not be greater than 8dBm in any 3kHz band at any time interval of continuous transmission.

3.3.2 Measuring Instruments

The measuring equipment is listed in the section 4 of this test report.

3.3.3 Test Procedures

1. The testing follows Measurement Procedure 10.2 Method PKPSD of FCC KDB Publication No. 558074 D01 DTS Meas. Guidance v03r03
2. The RF output of EUT was connected to the spectrum analyzer by RF cable and attenuator. The path loss was compensated to the results for each measurement.
3. Set to the maximum power setting and enable the EUT transmit continuously.
4. Make the measurement with the spectrum analyzer's resolution bandwidth (RBW) = 3 kHz. Video bandwidth VBW = 10 kHz In order to make an accurate measurement, set the span to 1.5 times DTS Channel Bandwidth. (6dB BW)
5. Detector = peak, Sweep time = auto couple, Trace mode = max hold, Allow trace to fully stabilize. Use the peak marker function to determine the maximum power level.
6. Measure and record the results in the test report.

3.3.4 Test Setup

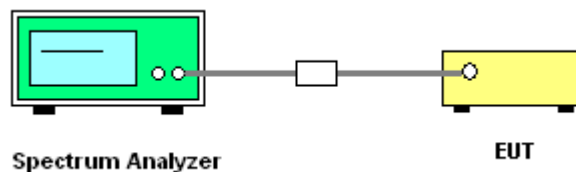



3.3.5 Test Result of Power Spectral Density

Please refer to Appendix A of this test report.

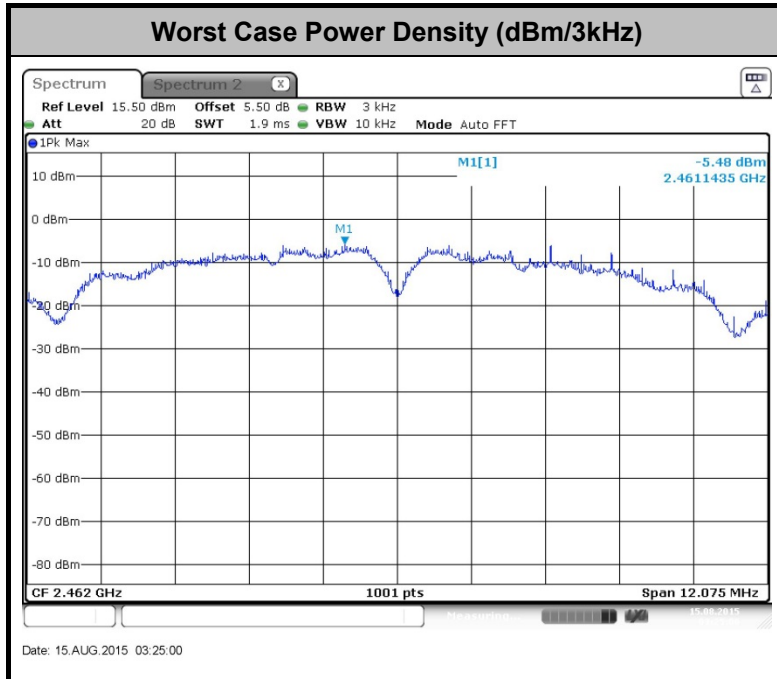

3.4 Conducted Band Edges and Spurious Emission Measurement

3.4.1 Limit of Conducted Band Edges and Spurious Emission Measurement

In any 100 kHz bandwidth outside of the authorized frequency band, the emissions which fall in the non-restricted bands shall be attenuated at least 20 dB / 30dB relative to the maximum PSD level in 100 kHz by RF conducted measurement and radiated emissions which fall in the restricted bands, as defined in Section 15.205(a), must also comply with the radiated emission limits specified in Section 15.209(a).

3.4.2 Measuring Instruments

The measuring equipment is listed in the section 4 of this test report.

3.4.3 Test Procedures

1. The testing follows FCC KDB Publication No. 558074 D01 DTS Meas. Guidance v03r03.
2. The RF output of EUT was connected to the spectrum analyzer by RF cable and attenuator. The path loss was compensated to the results for each measurement.
3. Set to the maximum power setting and enable the EUT transmit continuously.
4. Set RBW = 100 kHz, VBW=300 kHz, Peak Detector. Unwanted Emissions measured in any 100 kHz bandwidth outside of the authorized frequency band shall be attenuated by at least 20 dB relative to the maximum in-band peak PSD level in 100 kHz when maximum peak conducted output power procedure is used. If the transmitter complies with the conducted power limits based on the use of RMS averaging over a time interval, the attenuation required under this paragraph shall be 30 dB instead of 20 dB per 15.247(d).
5. Measure and record the results in the test report.
6. The RF fundamental frequency should be excluded against the limit line in the operating frequency band.

3.4.4 Test Setup

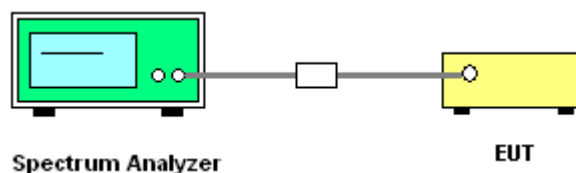



3.4.5 Test Result of Conducted Band Edges and Spurious Emission

| | | | |
|----------------|------------|---------------------|------------|
| Test Mode : | 802.11b | Temperature : | 24~25°C |
| Test Band : | 2.4GHz Low | Relative Humidity : | 49~51% |
| Test Channel : | 01 | Test Engineer : | Issac Song |

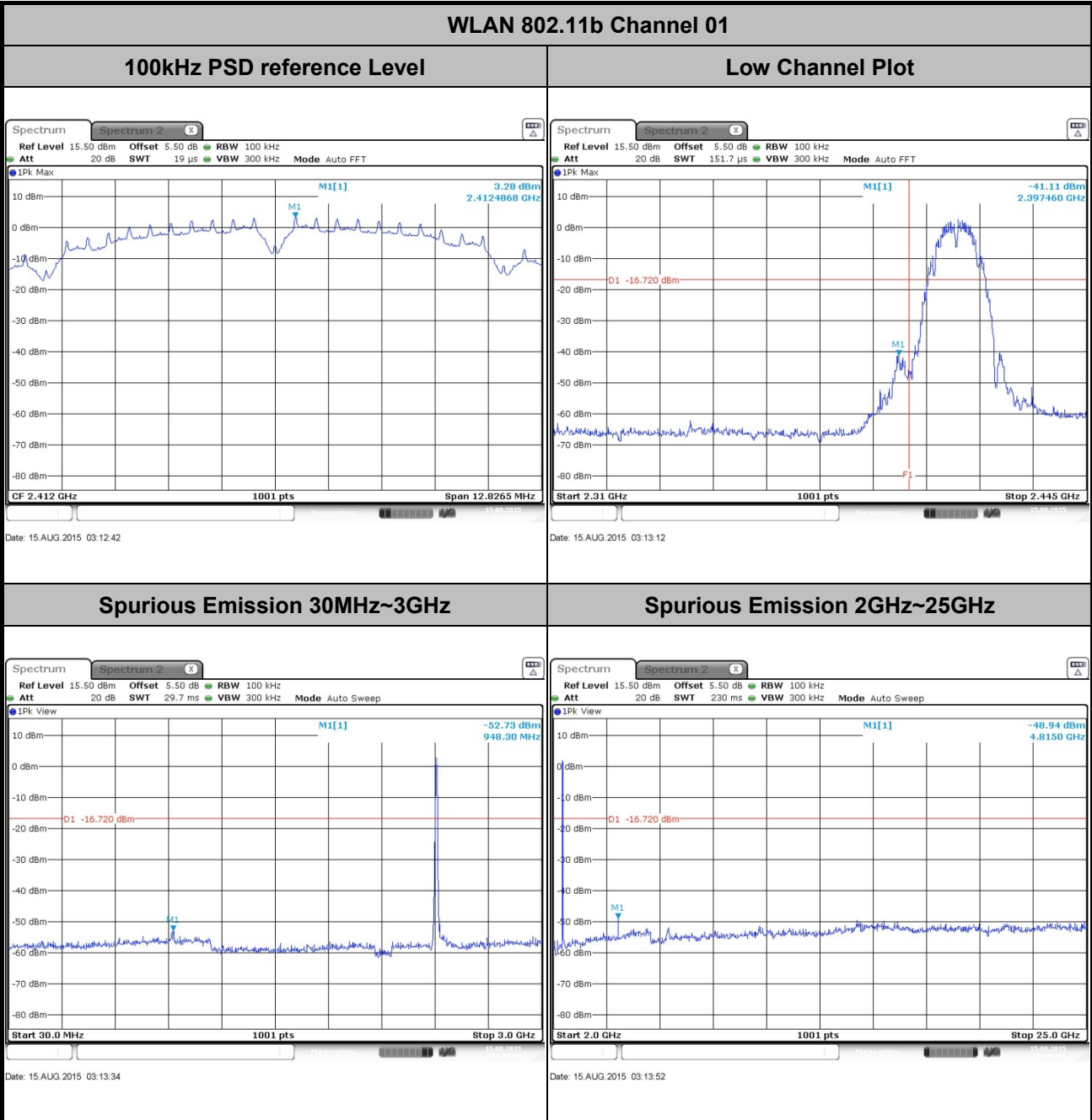



| | | | |
|----------------|------------|---------------------|------------|
| Test Mode : | 802.11b | Temperature : | 24~25°C |
| Test Band : | 2.4GHz Mid | Relative Humidity : | 49~51% |
| Test Channel : | 06 | Test Engineer : | Issac Song |

WLAN 802.11b Channel 06

100kHz PSD reference Level

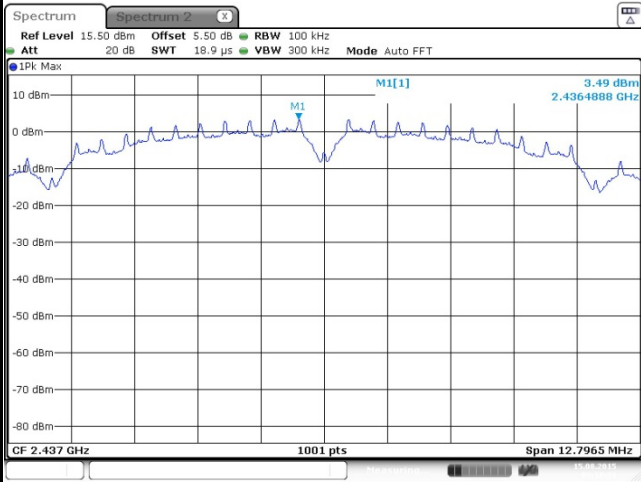

Date: 15.AUG.2015 03:18:33

Spurious Emission 30MHz~3GHz

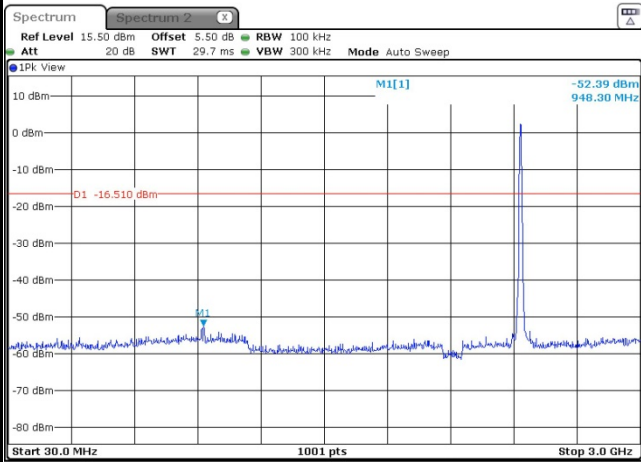

Date: 15.AUG.2015 03:19:53

Spurious Emission 2GHz~25GHz

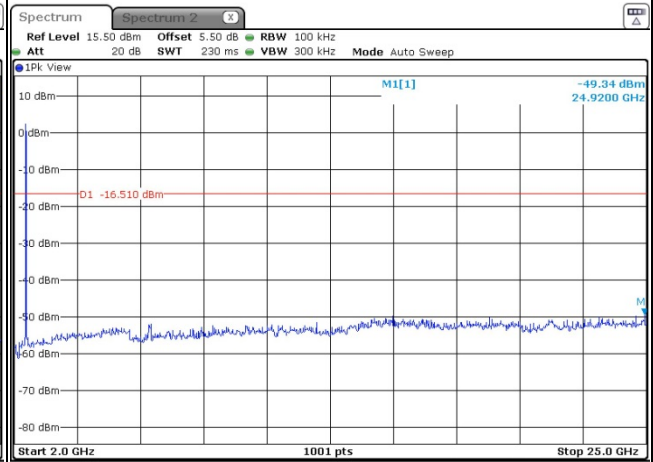

Date: 15.AUG.2015 03:20:11



| | | | |
|----------------|-------------|---------------------|------------|
| Test Mode : | 802.11b | Temperature : | 24~25°C |
| Test Band : | 2.4GHz High | Relative Humidity : | 49~51% |
| Test Channel : | 11 | Test Engineer : | Issac Song |

WLAN 802.11b Channel 11

100kHz PSD reference Level

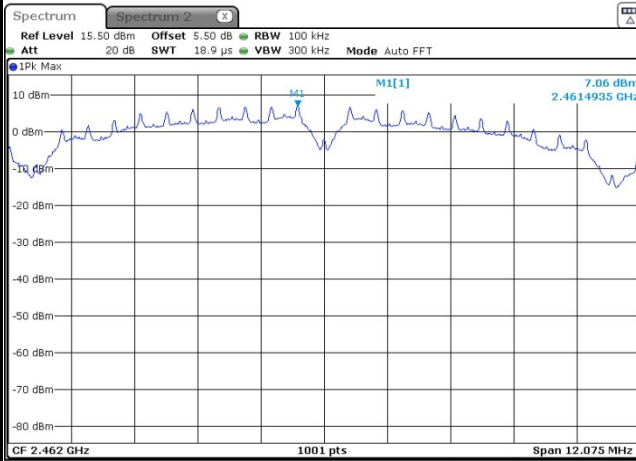

Date: 15.AUG.2015 03:25:20

High Channel Plot

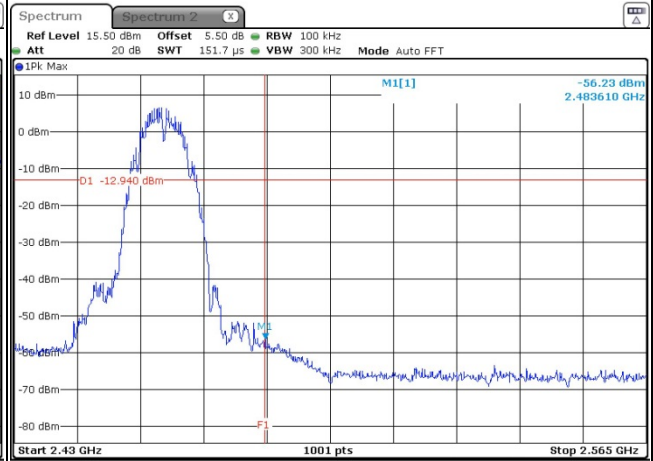

Date: 15.AUG.2015 03:25:34

Spurious Emission 30MHz~3GHz

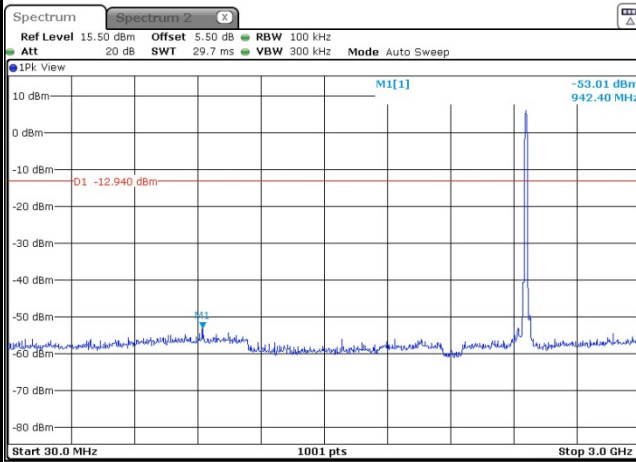

Date: 15.AUG.2015 03:26:46

Spurious Emission 2GHz~25GHz

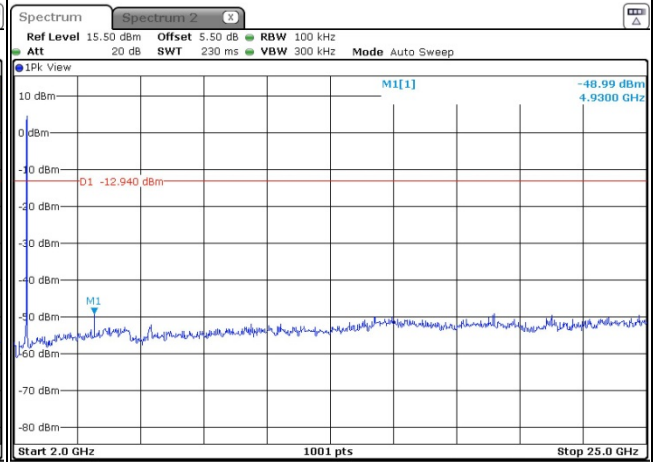

Date: 15.AUG.2015 03:27:04



| | | | |
|----------------|------------|---------------------|------------|
| Test Mode : | 802.11g | Temperature : | 24~25°C |
| Test Band : | 2.4GHz Low | Relative Humidity : | 49~51% |
| Test Channel : | 01 | Test Engineer : | Issac Song |

WLAN 802.11g Channel 01

100kHz PSD reference Level

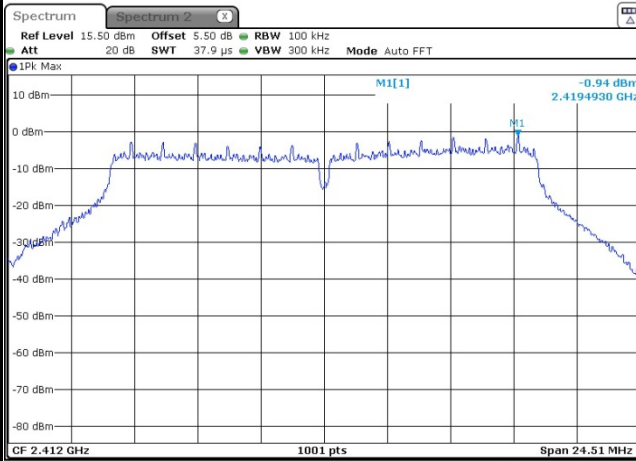

Date: 15.AUG.2015 03:51:39

Low Channel Plot

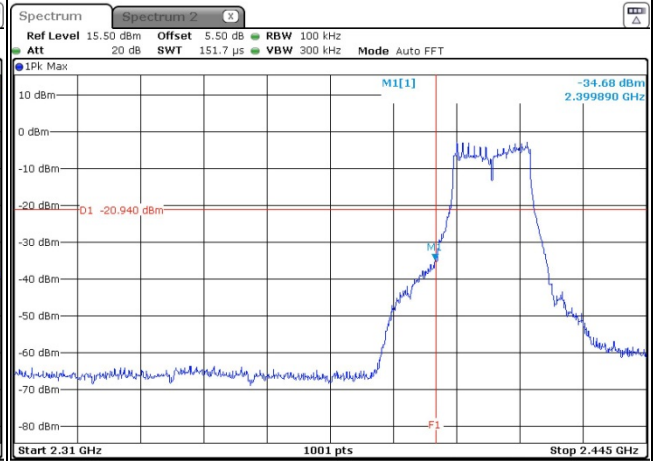

Date: 15.AUG.2015 03:52:13

Spurious Emission 30MHz~3GHz

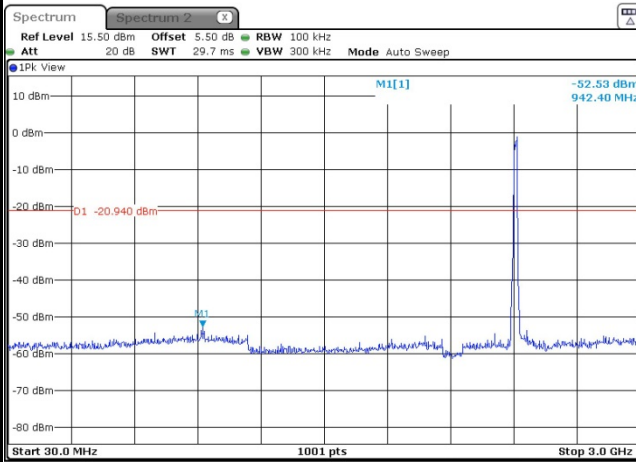

Date: 15.AUG.2015 03:52:55

Spurious Emission 2GHz~25GHz

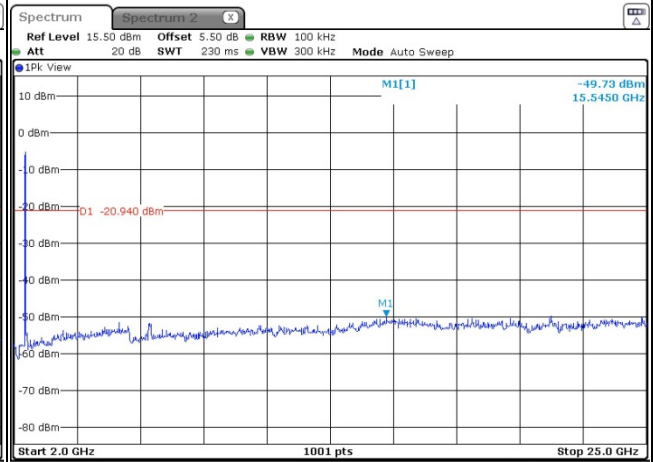

Date: 15.AUG.2015 03:53:12



| | | | |
|----------------|------------|---------------------|------------|
| Test Mode : | 802.11g | Temperature : | 24~25°C |
| Test Band : | 2.4GHz Mid | Relative Humidity : | 49~51% |
| Test Channel : | 06 | Test Engineer : | Issac Song |

WLAN 802.11g Channel 06

100kHz PSD reference Level

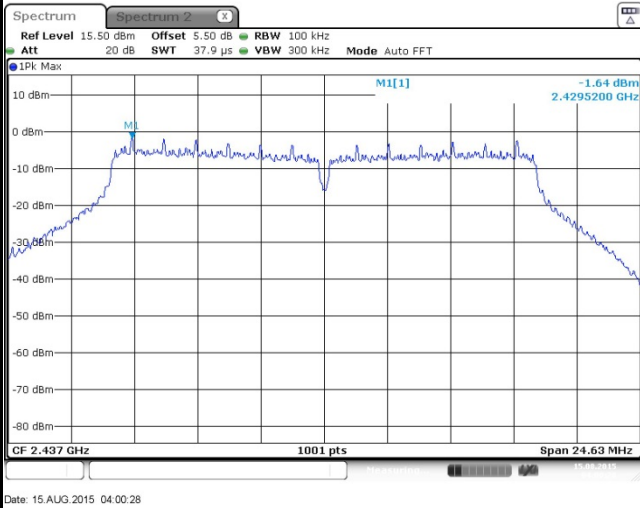

Spurious Emission 30MHz~3GHz

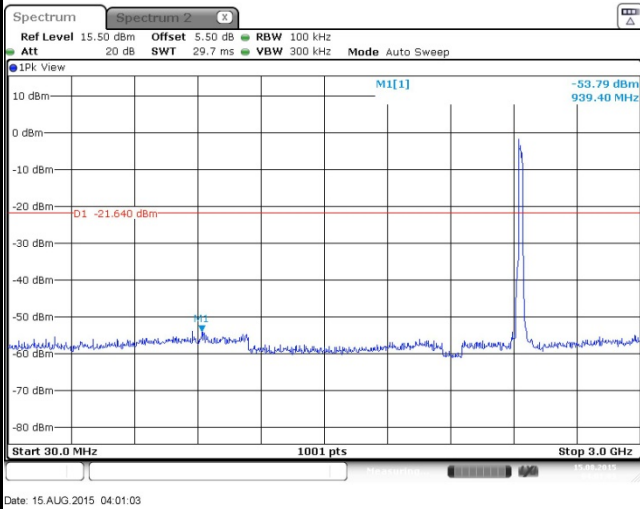

Spurious Emission 2GHz~25GHz

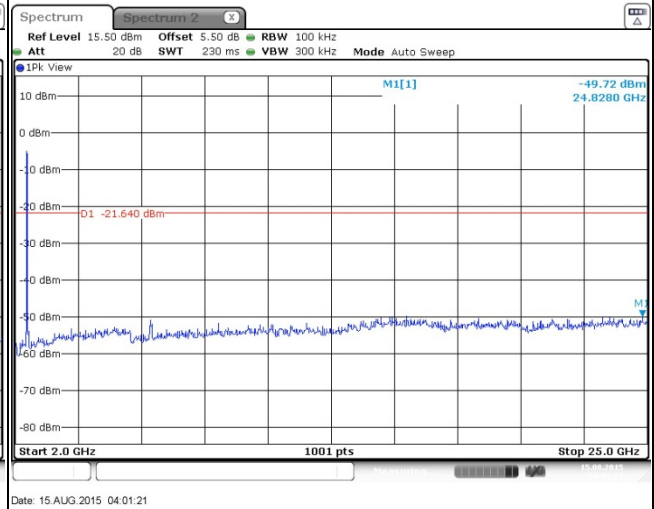



| | | | |
|----------------|-------------|---------------------|------------|
| Test Mode : | 802.11g | Temperature : | 24~25°C |
| Test Band : | 2.4GHz High | Relative Humidity : | 49~51% |
| Test Channel : | 11 | Test Engineer : | Issac Song |

WLAN 802.11g Channel 11

100kHz PSD reference Level

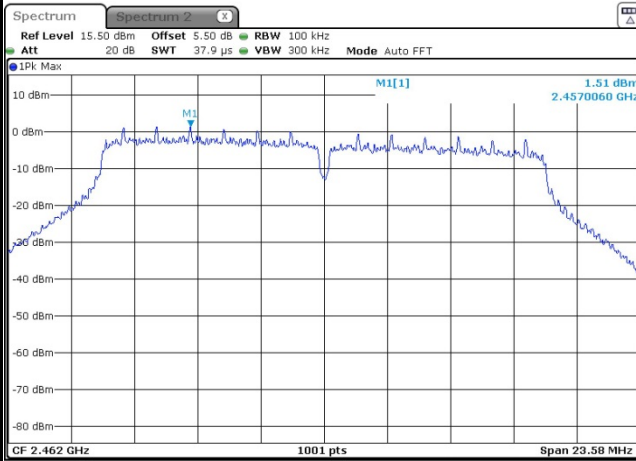

High Channel Plot

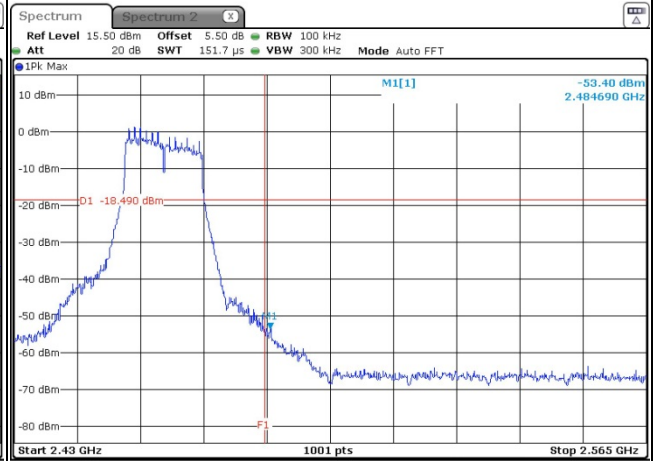

Spurious Emission 30MHz~3GHz

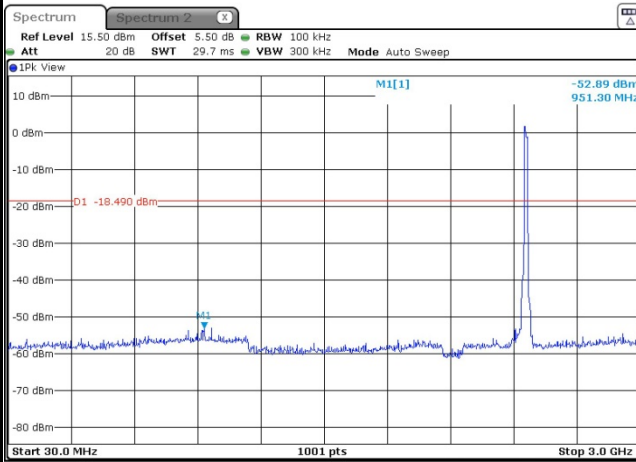

Spurious Emission 2GHz~25GHz

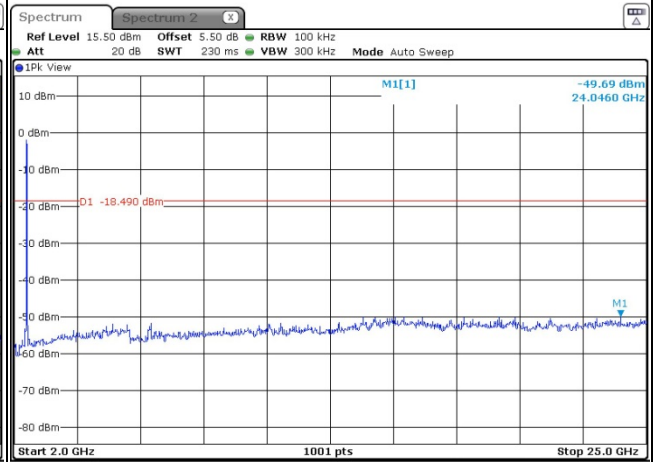



| | | | |
|----------------|--------------|---------------------|------------|
| Test Mode : | 802.11n HT20 | Temperature : | 24~25°C |
| Test Band : | 2.4GHz Low | Relative Humidity : | 49~51% |
| Test Channel : | 01 | Test Engineer : | Issac Song |

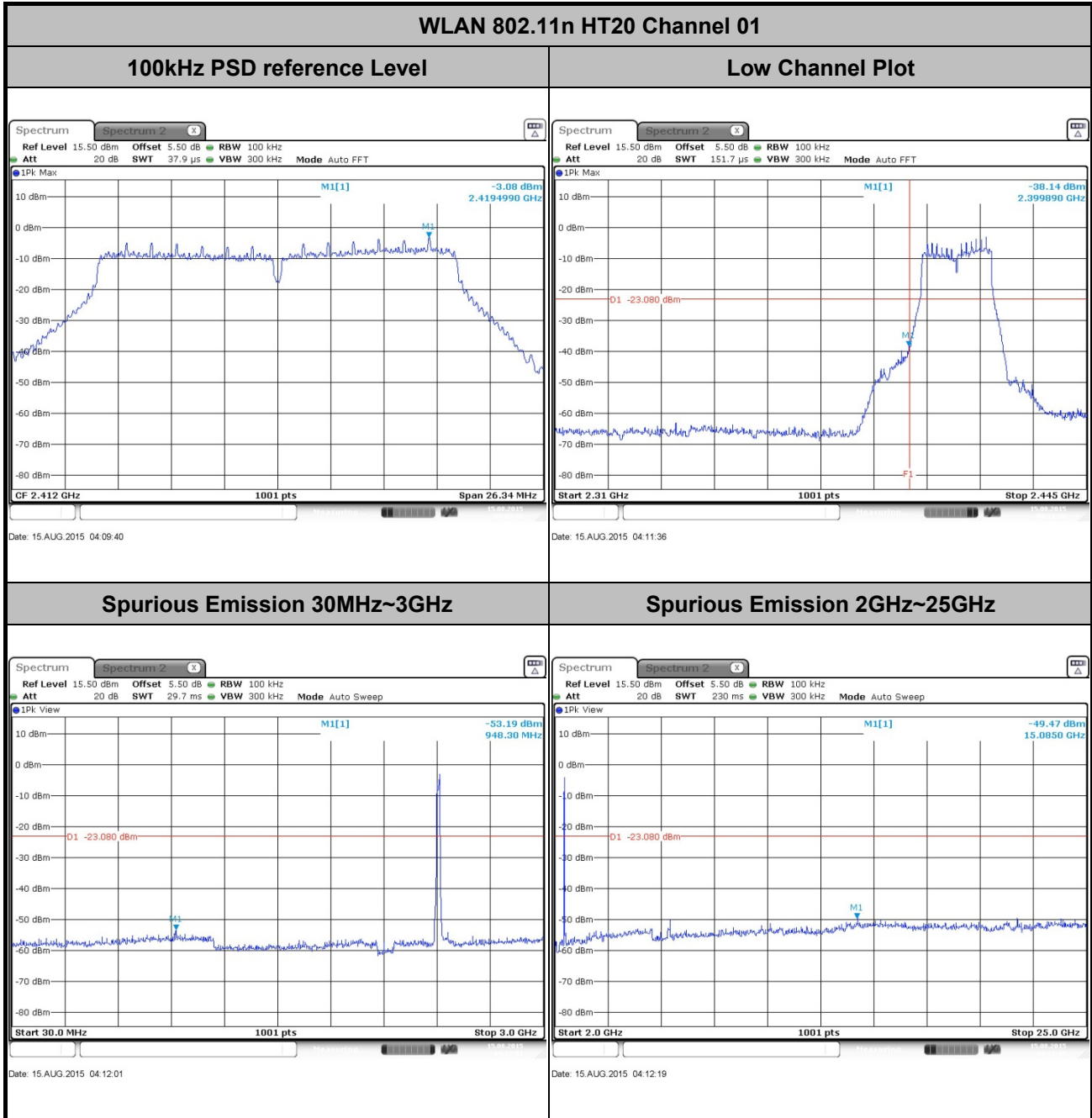



| | | | |
|----------------|--------------|---------------------|------------|
| Test Mode : | 802.11n HT20 | Temperature : | 24~25°C |
| Test Band : | 2.4GHz Mid | Relative Humidity : | 49~51% |
| Test Channel : | 06 | Test Engineer : | Issac Song |

WLAN 802.11n HT20 Channel 06

100kHz PSD reference Level

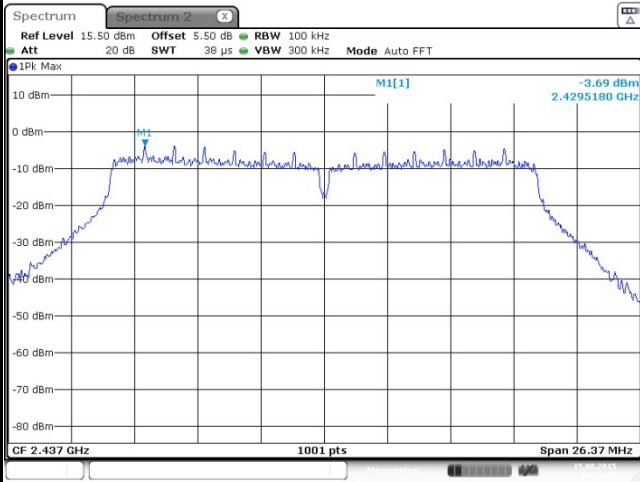

Spurious Emission 30MHz~3GHz

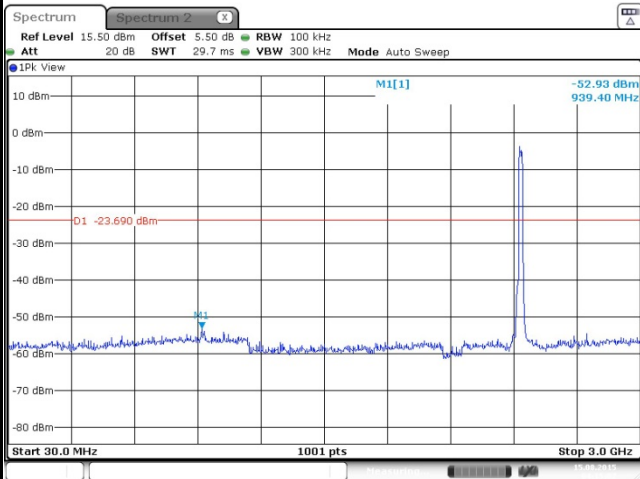

Spurious Emission 2GHz~25GHz

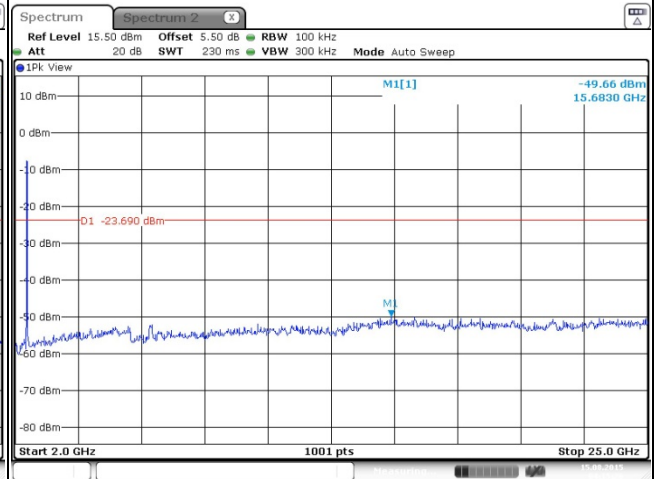



| | | | |
|----------------|--------------|---------------------|------------|
| Test Mode : | 802.11n HT20 | Temperature : | 24~25°C |
| Test Band : | 2.4GHz High | Relative Humidity : | 49~51% |
| Test Channel : | 11 | Test Engineer : | Issac Song |

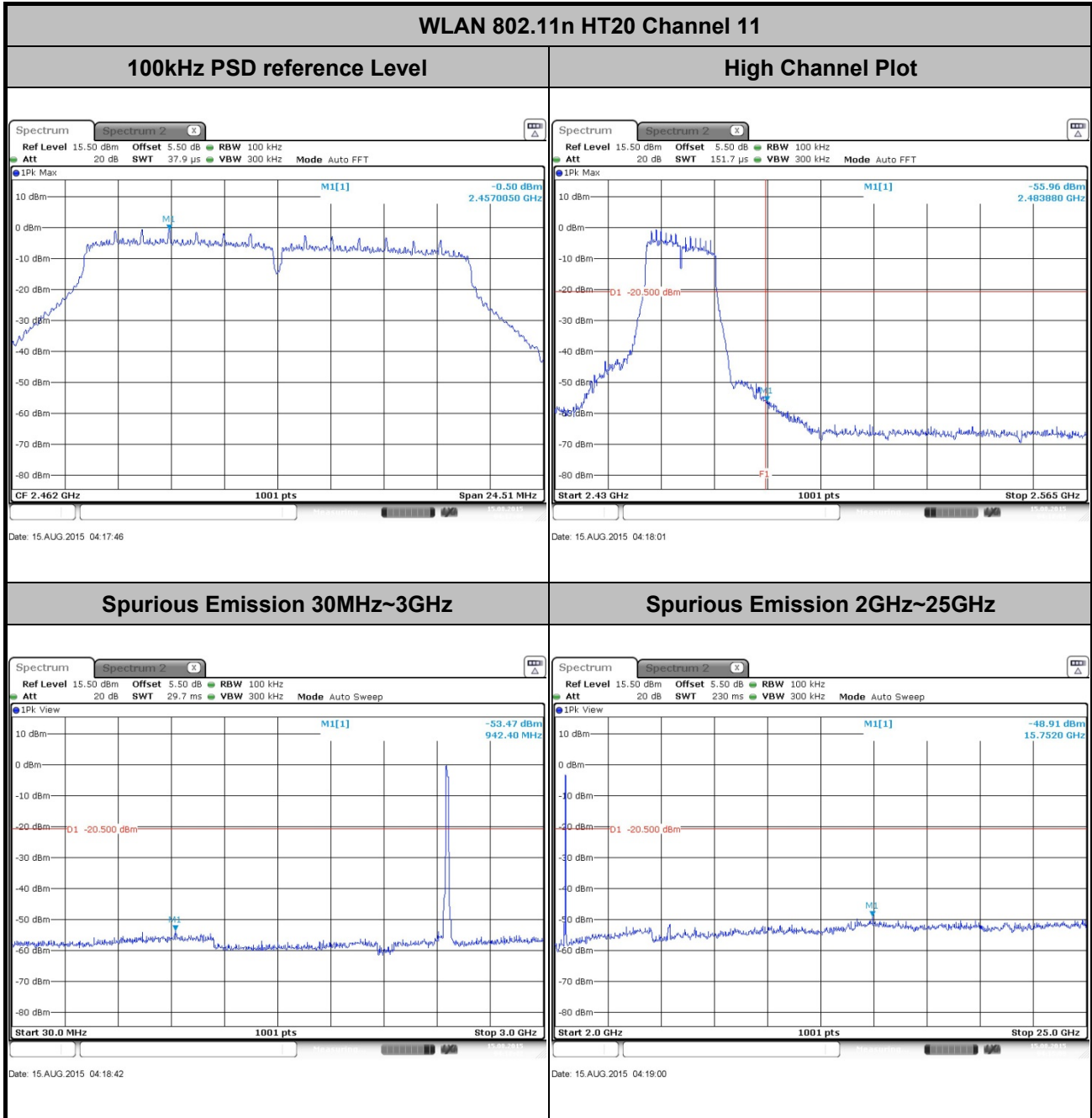



3.5 Radiated Band Edges and Spurious Emission Measurement

3.5.1 Limit of Radiated band edge and Spurious Emission Measurement

In any 100 kHz bandwidth outside the intentional radiator frequency band, all harmonics/spurious must be at least 20 dB below the highest emission level within the authorized band. If the output power of this device was measured by spectrum analyzer, the attenuation under this paragraph shall be 30 dB instead of 20 dB. In addition, radiated emissions which fall in the restricted bands must also comply with the FCC section 15.209 limits as below.

| Frequency (MHz) | Field Strength (microvolts/meter) | Measurement Distance (meters) |
|-----------------|-----------------------------------|-------------------------------|
| 0.009 – 0.490 | 2400/F(kHz) | 300 |
| 0.490 – 1.705 | 24000/F(kHz) | 30 |
| 1.705 – 30.0 | 30 | 30 |
| 30 – 88 | 100 | 3 |
| 88 – 216 | 150 | 3 |
| 216 - 960 | 200 | 3 |
| Above 960 | 500 | 3 |

3.5.2 Measuring Instruments

The measuring equipment is listed in the section 4 of this test report.



3.5.3 Test Procedures

1. The testing follows FCC KDB Publication No. 558074 D01 DTS Meas. Guidance v03r03.
2. The EUT was arranged to its worst case and then tune the antenna tower (from 1 m to 4 m) and turntable (from 0 degree to 360 degrees) to find the maximum reading. A pre-amp and a high pass filter are used for the test in order to get better signal level.
3. The EUT was placed on a turntable with 0.8 meter for frequency below 1GHz and 1.5 meter for frequency above 1GHz respectively above ground.
4. The EUT was set 3 meters from the interference receiving antenna, which was mounted on the top of a variable height antenna tower.
5. Corrected Reading: Antenna Factor + Cable Loss + Read Level - Preamp Factor = Level
6. For measurement below 1GHz, If the emission level of the EUT measured by the peak detector is 3 dB lower than the applicable limit, the peak emission level will be reported. Otherwise, the emission measurement will be repeated using the quasi-peak detector and reported.
7. Use the following spectrum analyzer settings:
 - (1) Span shall wide enough to fully capture the emission being measured;
 - (2) Set RBW=100 kHz for $f < 1 \text{ GHz}$; $\text{VBW} \geq \text{RBW}$; Sweep = auto; Detector function = peak; Trace = max hold;
 - (3) Set RBW = 1 MHz, VBW= 3MHz for $f \geq 1 \text{ GHz}$ for peak measurement.

For average measurement:

 - $\text{VBW} = 10 \text{ Hz}$, when duty cycle is no less than 98 percent.
 - $\text{VBW} \geq 1/T$, when duty cycle is less than 98 percent where T is the minimum transmission duration over which the transmitter is on and is transmitting at its maximum power control level for the tested mode of operation.

| Band | Duty Cycle(%) | T(ms) | 1/T(kHz) | VBW Setting |
|---------------------|---------------|-------|----------|-------------|
| 802.11b | 97.63 | 8.24 | 0.12 | 300Hz |
| 802.11g | 87.26 | 1.37 | 0.73 | 1kHz |
| 2.4GHz 802.11n HT20 | 86.64 | 1.28 | 0.78 | 1kHz |

3.5.4 Test Setup

For radiated emissions below 30MHz

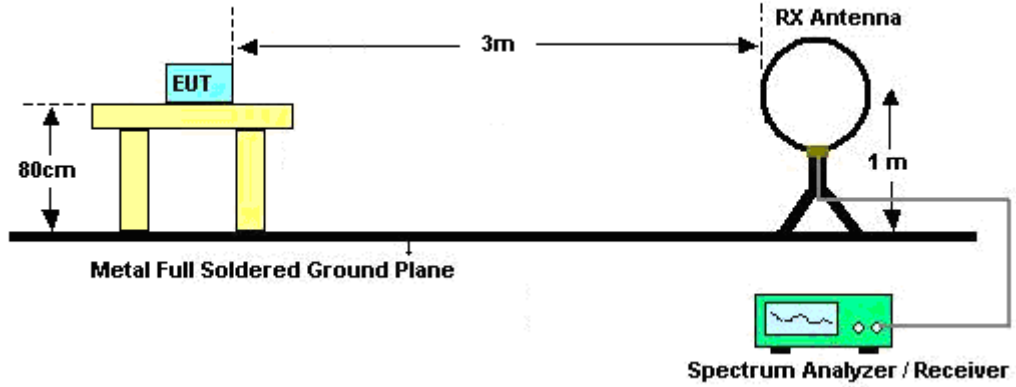

For radiated emissions from 30MHz to 1GHz

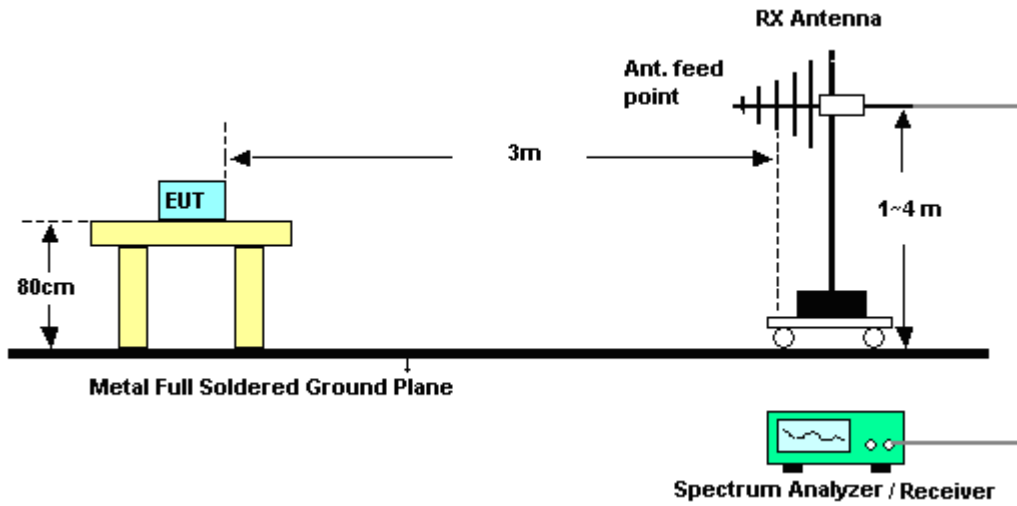

For radiated emissions above 1GHz

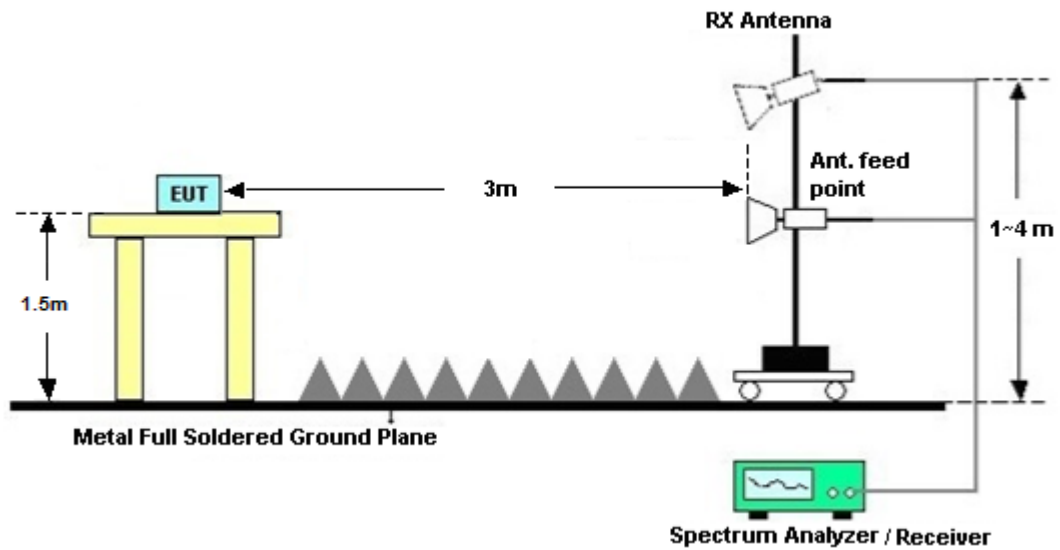

3.5.5 Test Results of Radiated Spurious Emissions (9kHz ~ 30MHz)

The low frequency, which started from 9 kHz to 30MHz, was pre-scanned and the result which was 20dB lower than the limit line per 15.31(o) was not reported.

3.5.6 Test Result of Radiated Spurious at Band Edges

Please refer to Appendix B.

3.5.7 Test Result of Radiated Spurious Emission (30MHz ~ 10th Harmonic)

Please refer to Appendix B.

3.6 AC Conducted Emission Measurement

3.6.1 Limit of AC Conducted Emission

For equipment that is designed to be connected to the public utility (AC) power line, the radio frequency voltage that is conducted back onto the AC power line on any frequency or frequencies within the band 150 kHz to 30 MHz shall not exceed the limits in the following table.

| Frequency of Emission (MHz) | Conducted Limit (dB μ V) | |
|--------------------------------|------------------------------|-----------|
| | Quasi-Peak | Average |
| 0.15-0.5 | 66 to 56* | 56 to 46* |
| 0.5-5 | 56 | 46 |
| 5-30 | 60 | 50 |

*Decreases with the logarithm of the frequency.

3.6.2 Measuring Instruments

The measuring equipment is listed in the section 4 of this test report.

3.6.3 Test Procedures

1. The EUT was placed 0.4 meter from the conducting wall of the shielding room, and it was kept at least 80 centimeters from any other grounded conducting surface.
2. Connect EUT to the power mains through a line impedance stabilization network (LISN).
3. All the support units are connecting to the other LISN.
4. The LISN provides 50 ohm coupling impedance for the measuring instrument.
5. The FCC states that a 50 ohm, 50 microhenry LISN should be used.
6. Both sides of AC line were checked for maximum conducted interference.
7. The frequency range from 150 kHz to 30 MHz was searched.
8. Set the test-receiver system to Peak Detect Function and specified bandwidth (IF bandwidth = 9kHz) with Maximum Hold Mode.

3.6.4 Test Setup

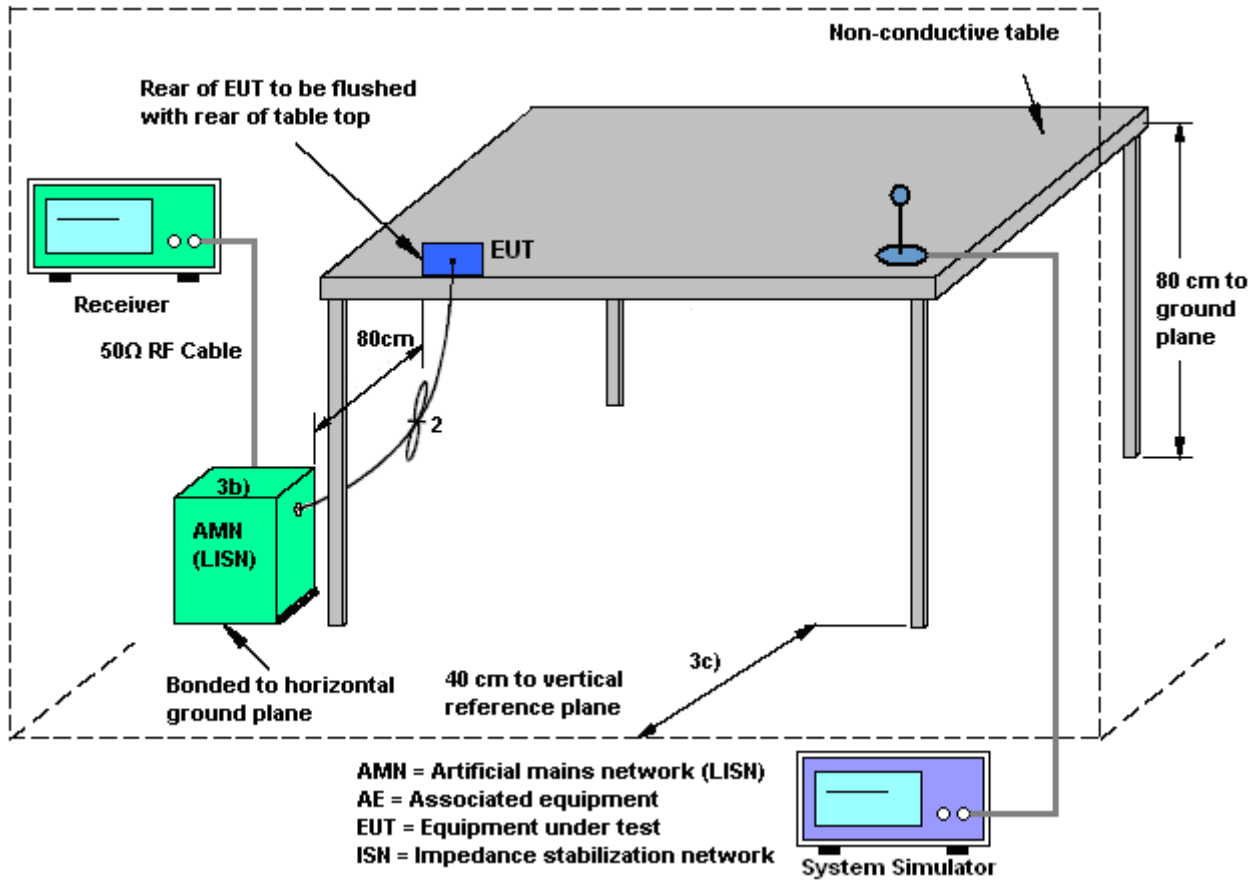



3.6.5 Test Result of AC Conducted Emission

| | | | |
|-----------------|---|---------------------|---------|
| Test Mode : | Mode 1 | Temperature : | 22~24°C |
| Test Engineer : | Amos Zhang | Relative Humidity : | 43~45% |
| Test Voltage : | 120Vac / 60Hz | Phase : | Line |
| Function Type : | GSM850 Idle + Bluetooth Link + WLAN Link + Earphone + USB Cable (Charging from Adapter) + SIM 1 | | |

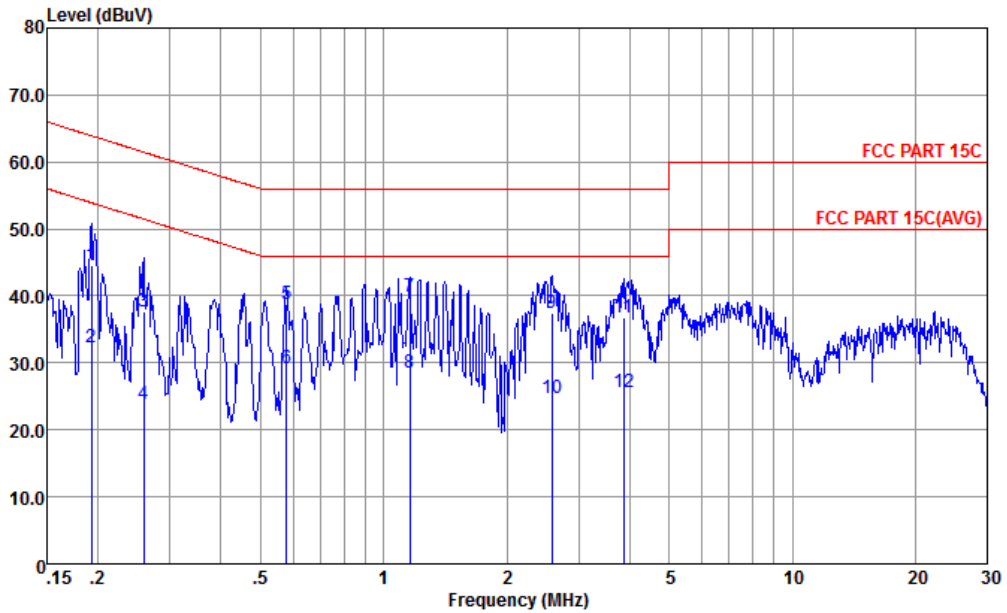

Site : CO01-KS
 Condition : FCC PART 15C LISN-L20140306 LINE

mode : Mode 1

| | Freq | Level | Over Limit | Limit Line | Read Level | LISN Factor | Cable Loss | Remark |
|-----|------|-------|------------|------------|------------|-------------|------------|---------|
| | MHz | dBuV | dB | dBuV | dBuV | dB | dB | |
| 1 | 0.19 | 44.48 | -19.45 | 63.93 | 32.90 | 1.09 | 10.49 | QP |
| 2 | 0.19 | 32.38 | -21.55 | 53.93 | 20.80 | 1.09 | 10.49 | Average |
| 3 | 0.26 | 37.69 | -23.78 | 61.47 | 26.31 | 0.85 | 10.53 | QP |
| 4 | 0.26 | 23.89 | -27.58 | 51.47 | 12.51 | 0.85 | 10.53 | Average |
| 5 | 0.58 | 38.73 | -17.27 | 56.00 | 27.90 | 0.20 | 10.63 | QP |
| 6 | 0.58 | 29.13 | -16.87 | 46.00 | 18.30 | 0.20 | 10.63 | Average |
| 7 * | 1.16 | 39.86 | -16.14 | 56.00 | 29.10 | 0.10 | 10.66 | QP |
| 8 | 1.16 | 28.56 | -17.44 | 46.00 | 17.80 | 0.10 | 10.66 | Average |
| 9 | 2.58 | 37.46 | -18.54 | 56.00 | 26.60 | 0.12 | 10.74 | QP |
| 10 | 2.58 | 24.66 | -21.34 | 46.00 | 13.80 | 0.12 | 10.74 | Average |
| 11 | 3.86 | 36.81 | -19.19 | 56.00 | 25.80 | 0.18 | 10.83 | QP |
| 12 | 3.86 | 25.61 | -20.39 | 46.00 | 14.60 | 0.18 | 10.83 | Average |



| | | | |
|-----------------|---|---------------------|---------|
| Test Mode : | Mode 1 | Temperature : | 22~24°C |
| Test Engineer : | Amos Zhang | Relative Humidity : | 43~45% |
| Test Voltage : | 120Vac / 60Hz | Phase : | Neutral |
| Function Type : | GSM850 Idle + Bluetooth Link + WLAN Link + Earphone + USB Cable (Charging from Adapter) + SIM 1 | | |

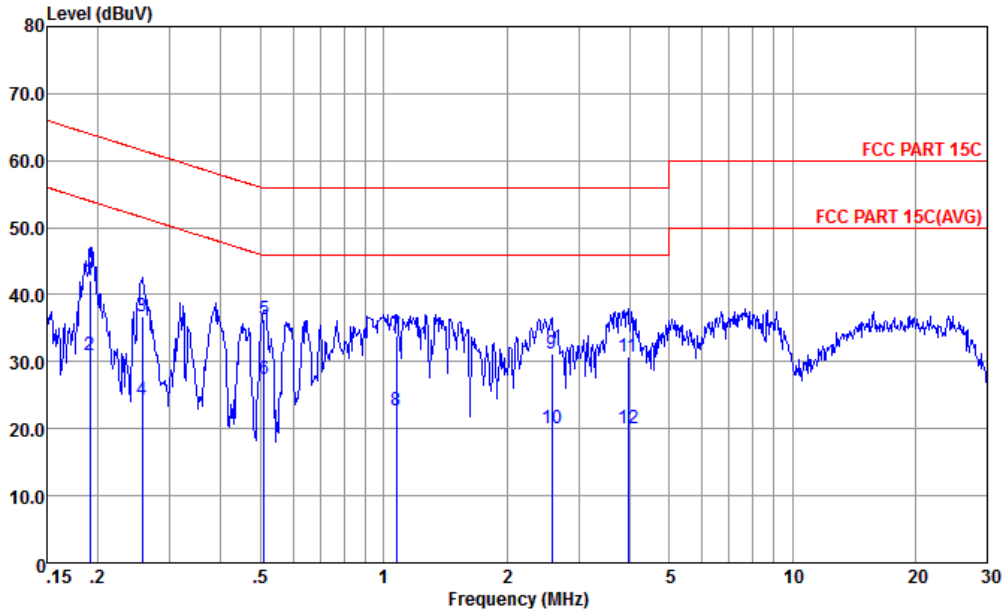

Site : CO01-KS
 Condition : FCC PART 15C LISN-N20140306 NEUTRAL

mode : Mode 1

| | Freq | Level | Over | Limit | Read | LISN | Cable | Remark |
|-----|------|-------|--------|-------|-------|--------|-------|---------|
| | MHz | dBuV | Limit | Line | Level | Factor | Loss | |
| | | | dB | dBuV | dBuV | dB | dB | |
| 1 | 0.19 | 42.08 | -21.90 | 63.98 | 30.49 | 1.10 | 10.49 | QP |
| 2 | 0.19 | 31.08 | -22.90 | 53.98 | 19.49 | 1.10 | 10.49 | Average |
| 3 | 0.26 | 36.71 | -24.85 | 61.56 | 25.30 | 0.88 | 10.53 | QP |
| 4 | 0.26 | 24.31 | -27.25 | 61.56 | 12.90 | 0.88 | 10.53 | Average |
| 5 | 0.51 | 36.22 | -19.78 | 56.00 | 25.29 | 0.30 | 10.63 | QP |
| 6 * | 0.51 | 27.42 | -18.58 | 46.00 | 16.49 | 0.30 | 10.63 | Average |
| 7 | 1.08 | 33.95 | -22.05 | 56.00 | 23.20 | 0.10 | 10.65 | QP |
| 8 | 1.08 | 22.65 | -23.35 | 46.00 | 11.90 | 0.10 | 10.65 | Average |
| 9 | 2.58 | 31.26 | -24.74 | 56.00 | 20.40 | 0.12 | 10.74 | QP |
| 10 | 2.58 | 20.06 | -25.94 | 46.00 | 9.20 | 0.12 | 10.74 | Average |
| 11 | 3.96 | 30.81 | -25.19 | 56.00 | 19.80 | 0.18 | 10.83 | QP |
| 12 | 3.96 | 20.11 | -25.89 | 46.00 | 9.10 | 0.18 | 10.83 | Average |



3.7 Antenna Requirements

3.7.1 Standard Applicable

If directional gain of transmitting antennas is greater than 6dBi, the power shall be reduced by the same level in dB comparing to gain minus 6dBi. For the fixed point-to-point operation, the power shall be reduced by one dB for every 3 dB that the directional gain of the antenna exceeds 6 dBi. The use of a permanently attached antenna or of an antenna that uses a unique coupling to the intentional radiator shall be considered sufficient to comply with the FCC rule.

3.7.2 Antenna Anti-Replacement Construction

An embedded-in antenna design is used.

3.7.3 Antenna Gain

The antenna peak gain of EUT is less than 6 dBi. Therefore, it is not necessary to reduce maximum peak output power limit.



4 List of Measuring Equipment

| Instrument | Manufacturer | Model No. | Serial No. | Characteristics | Calibration Date | Test Date | Due Date | Remark |
|--------------------------------------|--------------|-----------|------------------|----------------------------|------------------|---------------|---------------|-----------------------|
| Spectrum Analyzer | R&S | FSV30 | 101338 | 9kHz~30GHz | May 04, 2015 | Aug. 15, 2015 | May 03, 2016 | Conducted (TH01-KS) |
| Pulse Power Sensor | Anritsu | MA2411B | 0917070 | 30MHz~40GHz | Jan. 23, 2015 | Aug. 15, 2015 | Jan. 22, 2016 | Conducted (TH01-KS) |
| Power Meter | Anritsu | ML2495A | 1005002 | 50MHz Bandwidth | Jan. 23, 2015 | Aug. 15, 2015 | Jan. 22, 2016 | Conducted (TH01-KS) |
| EMI Test Receiver | R&S | ESR7 | 101403 | 9kHz~7GHz; Max 30dBm | Sep. 29, 2014 | Aug. 16, 2015 | Sep. 28, 2015 | Radiation (03CH02-KS) |
| Spectrum Analyzer | R&S | FSV40 | 101040 | 10kHz~40GHz; Max 30dBm | Sep. 25, 2014 | Aug. 16, 2015 | Sep. 24, 2015 | Radiation (03CH02-KS) |
| Loop Antenna | R&S | HFH2-Z2 | 100321 | 9kHz~30MHz | Nov. 13, 2014 | Aug. 16, 2015 | Nov. 12, 2015 | Radiation (03CH02-KS) |
| Bilog Antenna | TeseQ | CBL6112D | 37879 | 30MHz~2GHz | Sep. 13, 2014 | Aug. 16, 2015 | Sep. 12, 2015 | Radiation (03CH02-KS) |
| Double Ridge Horn Antenna | ETS-Lindgren | 3117 | 75957 | 1GHz~18GHz | Nov. 08, 2014 | Aug. 16, 2015 | Nov. 07, 2015 | Radiation (03CH02-KS) |
| Active Horn Antenna | com-power | AHA-118 | 701030 | 1GHz~18GHz | Nov. 08, 2014 | Aug. 16, 2015 | Nov. 07, 2015 | Radiation (03CH02-KS) |
| SHF-EHF Horn | com-power | AH-840 | 101070 | 18GHz~40GHz | Sep. 04, 2014 | Aug. 16, 2015 | Sep. 03, 2015 | Radiation (03CH02-KS) |
| Amplifier | com-power | PA-103A | 161069 | 1kHz~1000MHz / 32 dB | May 04, 2015 | Aug. 16, 2015 | May 03, 2016 | Radiation (03CH02-KS) |
| Amplifier | Agilent | 8449B | 3008A023 84 | 1GHz~26.5GHz Gain 30dB | Oct. 28, 2014 | Aug. 16, 2015 | Oct. 27, 2015 | Radiation (03CH02-KS) |
| AC Power Source | Chroma | 61601 | 616010002 473 | N/A | NCR | Aug. 16, 2015 | NCR | Radiation (03CH02-KS) |
| Turn Table | MF | MF7802 | N/A | 0~360 degree | NCR | Aug. 16, 2015 | NCR | Radiation (03CH02-KS) |
| Antenna Mast | MF | MF7802 | N/A | 1 m~4 m | NCR | Aug. 16, 2015 | NCR | Radiation (03CH02-KS) |
| EMI Receiver | R&S | ESCI7 | 100768 | 9kHz~7GHz | May 04, 2015 | Aug. 14, 2015 | May 03, 2016 | Conduction (CO01-KS) |
| AC LISN | MessTec | AN3016 | 060103 | 9kHz~30MHz | Oct. 25, 2014 | Aug. 14, 2015 | Oct. 24, 2015 | Conduction (CO01-KS) |
| AC LISN (for auxiliary equipment) | MessTec | AN3016 | 060105 | 9kHz~30MHz | Oct. 25, 2014 | Aug. 14, 2015 | Oct. 24, 2015 | Conduction (CO01-KS) |
| AC Power Source | Chroma | 61602 | ABP00000 0811 | AC 0V~300V, 45Hz~1000Hz | Oct. 25, 2014 | Aug. 14, 2015 | Oct. 24, 2015 | Conduction (CO01-KS) |



5 Uncertainty of Evaluation

Uncertainty of Conducted Emission Measurement (150kHz ~ 30MHz)

| | |
|---|--------|
| Measuring Uncertainty for a Level of Confidence of 95% ($U = 2Uc(y)$) | 2.3 dB |
|---|--------|

Uncertainty of Radiated Emission Measurement (30 MHz ~ 1000 MHz)

| | |
|---|--------|
| Measuring Uncertainty for a Level of Confidence of 95% ($U = 2Uc(y)$) | 5.1 dB |
|---|--------|



Appendix A. Conducted Test Results

| | | | | |
|----------------|------------|--------------------|-------|----|
| Test Engineer: | Issac Song | Temperature: | 21~25 | °C |
| Test Date: | 2015/8/15 | Relative Humidity: | 51~54 | % |

TEST RESULTS DATA
6dB and 99% Occupied Bandwidth

| 2.4GHz Band | | | | | | | | |
|-------------|-----------|-----------------|-----|-------------|-----------------------|--------------|--------------------|-----------|
| Mod. | Data Rate | N _{TX} | CH. | Freq. (MHz) | 99% Occupied BW (MHz) | 6dB BW (MHz) | 6dB BW Limit (MHz) | Pass/Fail |
| 11b | 1Mbps | 1 | 1 | 2412 | 13.44 | 8.55 | 0.50 | Pass |
| 11b | 1Mbps | 1 | 6 | 2437 | 13.44 | 8.53 | 0.50 | Pass |
| 11b | 1Mbps | 1 | 11 | 2462 | 12.84 | 8.05 | 0.50 | Pass |
| 11g | 6Mbps | 1 | 1 | 2412 | 18.23 | 16.34 | 0.50 | Pass |
| 11g | 6Mbps | 1 | 6 | 2437 | 19.08 | 16.42 | 0.50 | Pass |
| 11g | 6Mbps | 1 | 11 | 2462 | 18.38 | 15.72 | 0.50 | Pass |
| HT20 | MCS0 | 1 | 1 | 2412 | 19.18 | 17.56 | 0.50 | Pass |
| HT20 | MCS0 | 1 | 6 | 2437 | 19.23 | 17.58 | 0.50 | Pass |
| HT20 | MCS0 | 1 | 11 | 2462 | 18.78 | 16.34 | 0.50 | Pass |

TEST RESULTS DATA
Peak Power Table

| 2.4GHz Band | | | | | | | | | | |
|-------------|-----------|-----|-----|-------------|----------------------------|-----------------------------|----------|------------------|------------------------|------------|
| Mod. | Data Rate | Ntx | CH. | Freq. (MHz) | Peak Conducted Power (dBm) | Conducted Power Limit (dBm) | DG (dBi) | EIRP Power (dBm) | EIRP Power Limit (dBm) | Pass /Fail |
| 11b | 1Mbps | 1 | 1 | 2412 | 14.52 | 30.00 | 1.60 | 16.12 | 36.00 | Pass |
| 11b | 1Mbps | 1 | 6 | 2437 | 13.93 | 30.00 | 1.60 | 15.53 | 36.00 | Pass |
| 11b | 1Mbps | 1 | 11 | 2462 | 17.48 | 30.00 | 1.60 | 19.08 | 36.00 | Pass |
| 11g | 6Mbps | 1 | 1 | 2412 | 19.45 | 30.00 | 1.60 | 21.05 | 36.00 | Pass |
| 11g | 6Mbps | 1 | 6 | 2437 | 19.04 | 30.00 | 1.60 | 20.64 | 36.00 | Pass |
| 11g | 6Mbps | 1 | 11 | 2462 | 21.59 | 30.00 | 1.60 | 23.19 | 36.00 | Pass |
| HT20 | MCS0 | 1 | 1 | 2412 | 17.53 | 30.00 | 1.60 | 19.13 | 36.00 | Pass |
| HT20 | MCS0 | 1 | 6 | 2437 | 16.97 | 30.00 | 1.60 | 18.57 | 36.00 | Pass |
| HT20 | MCS0 | 1 | 11 | 2462 | 20.17 | 30.00 | 1.60 | 21.77 | 36.00 | Pass |

TEST RESULTS DATA
Average Power Table
(Reporting Only)

| 2.4GHz Band | | | | | | |
|-------------|-----------|-----------------|-----|-------------|------------------|-------------------------------|
| Mod. | Data Rate | N _{TX} | CH. | Freq. (MHz) | Duty Factor (dB) | Average Conducted Power (dBm) |
| 11b | 1Mbps | 1 | 1 | 2412 | 0.10 | 11.56 |
| 11b | 1Mbps | 1 | 6 | 2437 | 0.10 | 11.14 |
| 11b | 1Mbps | 1 | 11 | 2462 | 0.10 | 14.65 |
| 11g | 6Mbps | 1 | 1 | 2412 | 0.59 | 8.92 |
| 11g | 6Mbps | 1 | 6 | 2437 | 0.59 | 8.70 |
| 11g | 6Mbps | 1 | 11 | 2462 | 0.59 | 11.71 |
| HT20 | MCS0 | 1 | 1 | 2412 | 0.62 | 6.98 |
| HT20 | MCS0 | 1 | 6 | 2437 | 0.62 | 6.75 |
| HT20 | MCS0 | 1 | 11 | 2462 | 0.62 | 9.74 |

TEST RESULTS DATA
Peak Power Density

| 2.4GHz Band | | | | | | | | |
|-------------|-----------|-----------------|-----|-------------|----------------------|----------|----------------------------|-----------|
| Mod. | Data Rate | N _{TX} | CH. | Freq. (MHz) | Peak PSD (dBm /3kHz) | DG (dBi) | Peak PSD Limit (dBm /3kHz) | Pass/Fail |
| 11b | 1Mbps | 1 | 1 | 2412 | -9.48 | 1.60 | 8.00 | Pass |
| 11b | 1Mbps | 1 | 6 | 2437 | -9.37 | 1.60 | 8.00 | Pass |
| 11b | 1Mbps | 1 | 11 | 2462 | -5.48 | 1.60 | 8.00 | Pass |
| 11g | 6Mbps | 1 | 1 | 2412 | -13.23 | 1.60 | 8.00 | Pass |
| 11g | 6Mbps | 1 | 6 | 2437 | -13.05 | 1.60 | 8.00 | Pass |
| 11g | 6Mbps | 1 | 11 | 2462 | -11.57 | 1.60 | 8.00 | Pass |
| HT20 | MCS0 | 1 | 1 | 2412 | -16.38 | 1.60 | 8.00 | Pass |
| HT20 | MCS0 | 1 | 6 | 2437 | -16.50 | 1.60 | 8.00 | Pass |
| HT20 | MCS0 | 1 | 11 | 2462 | -12.76 | 1.60 | 8.00 | Pass |



Appendix B. Radiated Spurious Emission

2.4GHz 2400~2483.5MHz

WIFI 802.11b (Band Edge @ 3m)

| WIFI | Note | Frequency | Level | Over | Limit | Read | Antenna | Cable | Preamp | Ant | Table | Peak | Pol. |
|-----------------------------|---|-----------|------------|--------|------------|----------|----------|--------|--------|--------|---------|-------|-------|
| Ant. | | | | Limit | Line | Level | Factor | Loss | Factor | Pos | Pos | Avg. | |
| 1 | | (MHz) | (dBμV/m) | (dB) | (dBμV/m) | (dBμV) | (dB/m) | (dB) | (dB) | (cm) | (deg) | (P/A) | (H/V) |
| 802.11b CH 01 2412MHz | * | 2413.36 | 96.01 | - | - | 101.14 | 27.13 | 4.74 | 37 | 233 | 336 | P | H |
| | * | 2412.692 | 91.54 | - | - | 96.67 | 27.13 | 4.74 | 37 | 233 | 336 | A | H |
| | | 2389.65 | 41.28 | -32.72 | 74 | 46.58 | 27 | 4.72 | 37.02 | 233 | 336 | P | H |
| | | 2389.83 | 28.5 | -25.5 | 54 | 33.8 | 27 | 4.72 | 37.02 | 233 | 336 | A | H |
| | * | 2413.444 | 100.75 | - | - | 105.88 | 27.13 | 4.74 | 37 | 150 | 293 | P | V |
| | * | 2412.775 | 96.06 | - | - | 101.19 | 27.13 | 4.74 | 37 | 150 | 293 | A | V |
| | | 2389.83 | 44.82 | -29.18 | 74 | 50.12 | 27 | 4.72 | 37.02 | 150 | 293 | P | V |
| | | 2389.92 | 32 | -22 | 54 | 37.3 | 27 | 4.72 | 37.02 | 150 | 293 | A | V |
| 802.11b CH 06 2437MHz | * | 2438.493 | 94.28 | - | - | 99.09 | 27.39 | 4.77 | 36.97 | 150 | 214 | P | H |
| | * | 2437.742 | 91.66 | - | - | 96.47 | 27.39 | 4.77 | 36.97 | 150 | 214 | A | H |
| | * | 2435.655 | 97.65 | - | - | 102.62 | 27.26 | 4.76 | 36.99 | 150 | 293 | P | V |
| | * | 2436.239 | 93.29 | - | - | 98.26 | 27.26 | 4.76 | 36.99 | 150 | 293 | A | V |
| 802.11b CH 11 2462MHz | * | 2460.621 | 97.37 | - | - | 102.03 | 27.51 | 4.79 | 36.96 | 225 | 214 | P | H |
| | * | 2461.206 | 92.75 | - | - | 97.41 | 27.51 | 4.79 | 36.96 | 225 | 214 | A | H |
| | | 2483.96 | 46.64 | -27.36 | 74 | 51.14 | 27.64 | 4.8 | 36.94 | 225 | 214 | P | H |
| | | 2483.72 | 29.88 | -24.12 | 54 | 34.38 | 27.64 | 4.8 | 36.94 | 225 | 214 | A | H |
| | * | 2460.538 | 101.52 | - | - | 106.18 | 27.51 | 4.79 | 36.96 | 150 | 295 | P | V |
| | * | 2461.206 | 97.15 | - | - | 101.81 | 27.51 | 4.79 | 36.96 | 150 | 295 | A | V |
| | | 2483.88 | 45.15 | -28.85 | 74 | 49.65 | 27.64 | 4.8 | 36.94 | 150 | 295 | P | V |
| | | 2483.6 | 32.36 | -21.64 | 54 | 36.86 | 27.64 | 4.8 | 36.94 | 150 | 295 | A | V |
| Remark | 1. No other spurious found. 2. All results are PASS against Peak and Average limit line. | | | | | | | | | | | | |



2.4GHz 2400~2483.5MHz
WIFI 802.11b (Harmonic @ 3m)

| WIFI Ant. 1 | Note | Frequency (MHz) | Level (dBμV/m) | Over Limit (dB) | Limit Line (dBμV/m) | Read Level (dBμV) | Antenna Factor (dB/m) | Cable Loss (dB) | Preamp Factor (dB) | Ant Pos (cm) | Table Pos (deg) | Peak Avg. (P/A) | Pol. (H/V) |
|-----------------------------|---|-------------------|------------------|-------------------|-----------------------|---------------------|-------------------------|-------------------|----------------------|----------------|-------------------|-----------------|------------|
| 802.11b CH 01 2412MHz | | 4824 | 46.11 | -27.89 | 74 | 44.45 | 31.51 | 6.83 | 36.68 | 150 | 122 | P | H |
| | | 4824 | 42.93 | -31.07 | 74 | 41.27 | 31.51 | 6.83 | 36.68 | 150 | 199 | P | V |
| 802.11b CH 06 2437MHz | | 4874 | 45.9 | -28.1 | 74 | 44.1 | 31.59 | 6.87 | 36.66 | 150 | 326 | P | H |
| | | 7311 | 45.86 | -28.14 | 74 | 39.95 | 34.03 | 8.57 | 36.69 | 150 | 187 | P | H |
| | | 4874 | 43.37 | -30.63 | 74 | 41.57 | 31.59 | 6.87 | 36.66 | 150 | 178 | P | V |
| | | 7311 | 45.53 | -28.47 | 74 | 39.62 | 34.03 | 8.57 | 36.69 | 150 | 205 | P | V |
| 802.11b CH 11 2462MHz | | 4923 | 45.81 | -28.19 | 74 | 43.87 | 31.67 | 6.92 | 36.65 | 150 | 21 | P | H |
| | | 7386 | 47.6 | -26.4 | 74 | 41.41 | 34.29 | 8.68 | 36.78 | 150 | 115 | P | H |
| | | 4923 | 42.6 | -31.4 | 74 | 40.66 | 31.67 | 6.92 | 36.65 | 150 | 104 | P | V |
| | | 7386 | 46.1 | -27.9 | 74 | 39.91 | 34.29 | 8.68 | 36.78 | 150 | 295 | P | V |
| Remark | 1. No other spurious found. 2. All results are PASS against Peak and Average limit line. | | | | | | | | | | | | |



**2.4GHz 2400~2483.5MHz
WIFI 802.11g (Band Edge @ 3m)**

| WIFI Ant. 1 | Note | Frequency (MHz) | Level (dBμV/m) | Over Limit (dB) | Limit Line (dBμV/m) | Read Level (dBμV) | Antenna Factor (dB/m) | Cable Loss (dB) | Preamp Factor (dB) | Ant Pos (cm) | Table Pos (deg) | Peak Avg. (P/A) | Pol. (H/V) |
|-----------------------------|---|-------------------|------------------|-------------------|-----------------------|---------------------|-------------------------|-------------------|----------------------|----------------|-------------------|-------------------|--------------|
| 802.11g CH 01 2412MHz | * | 2417.117 | 98.78 | - | - | 103.91 | 27.13 | 4.74 | 37 | 300 | 135 | P | H |
| | * | 2415.781 | 87.56 | - | - | 92.69 | 27.13 | 4.74 | 37 | 300 | 135 | A | H |
| | | 2389.92 | 55.83 | -18.17 | 74 | 61.13 | 27 | 4.72 | 37.02 | 300 | 135 | P | H |
| | | 2389.92 | 36.04 | -17.96 | 54 | 41.34 | 27 | 4.72 | 37.02 | 300 | 135 | A | H |
| | * | 2417.451 | 101.15 | - | - | 106.28 | 27.13 | 4.74 | 37 | 150 | 56 | P | V |
| | * | 2416.115 | 91.01 | - | - | 96.14 | 27.13 | 4.74 | 37 | 150 | 56 | A | V |
| | | 2389.74 | 61.13 | -12.87 | 74 | 66.43 | 27 | 4.72 | 37.02 | 150 | 56 | P | V |
| | | 2390 | 39.87 | -14.13 | 54 | 45.17 | 27 | 4.72 | 37.02 | 150 | 56 | A | V |
| 802.11g CH 06 2437MHz | * | 2443.837 | 96.06 | - | - | 100.87 | 27.39 | 4.77 | 36.97 | 281 | 228 | P | H |
| | * | 2444.338 | 85.76 | - | - | 90.57 | 27.39 | 4.77 | 36.97 | 281 | 228 | A | H |
| | * | 2443.503 | 99.95 | - | - | 104.76 | 27.39 | 4.77 | 36.97 | 150 | 268 | P | V |
| | * | 2443.921 | 89.34 | - | - | 94.15 | 27.39 | 4.77 | 36.97 | 150 | 268 | A | V |
| 802.11g CH 11 2462MHz | * | 2455.361 | 100.68 | - | - | 105.34 | 27.51 | 4.79 | 36.96 | 300 | 236 | P | H |
| | * | 2455.11 | 90.44 | - | - | 95.1 | 27.51 | 4.79 | 36.96 | 300 | 236 | A | H |
| | | 2484.64 | 57.11 | -16.89 | 74 | 61.61 | 27.64 | 4.8 | 36.94 | 300 | 236 | P | H |
| | | 2483.52 | 36.85 | -17.15 | 54 | 41.35 | 27.64 | 4.8 | 36.94 | 300 | 236 | A | H |
| | * | 2455.444 | 104.25 | - | - | 108.91 | 27.51 | 4.79 | 36.96 | 150 | 296 | P | V |
| | * | 2455.528 | 94.2 | - | - | 98.86 | 27.51 | 4.79 | 36.96 | 150 | 296 | A | V |
| | | 2483.88 | 63.26 | -10.74 | 74 | 67.76 | 27.64 | 4.8 | 36.94 | 150 | 296 | P | V |
| | | 2483.56 | 41.99 | -12.01 | 54 | 46.49 | 27.64 | 4.8 | 36.94 | 150 | 296 | A | V |
| Remark | 1. No other spurious found. 2. All results are PASS against Peak and Average limit line. | | | | | | | | | | | | |



**2.4GHz 2400~2483.5MHz
WIFI 802.11g (Harmonic @ 3m)**

| WIFI Ant. 1 | Note | Frequency (MHz) | Level (dBμV/m) | Over Limit (dB) | Limit Line (dBμV/m) | Read Level (dBμV) | Antenna Factor (dB/m) | Cable Loss (dB) | Preamp Factor (dB) | Ant Pos (cm) | Table Pos (deg) | Peak Avg. (P/A) | Pol. (H/V) |
|-----------------------------|---|-------------------|------------------|-------------------|-----------------------|---------------------|-------------------------|-------------------|----------------------|----------------|-------------------|-----------------|------------|
| 802.11g CH 01 2412MHz | | 4824 | 41.13 | -32.87 | 74 | 39.47 | 31.51 | 6.83 | 36.68 | 150 | 166 | P | H |
| | | 4824 | 42.19 | -31.81 | 74 | 40.53 | 31.51 | 6.83 | 36.68 | 150 | 219 | P | V |
| 802.11g CH 06 2437MHz | | 4874 | 41.43 | -32.57 | 74 | 39.63 | 31.59 | 6.87 | 36.66 | 200 | 62 | P | H |
| | | 7311 | 44.98 | -29.02 | 74 | 39.07 | 34.03 | 8.57 | 36.69 | 169 | 188 | P | H |
| | | 4874 | 42.12 | -31.88 | 74 | 40.32 | 31.59 | 6.87 | 36.66 | 150 | 133 | P | V |
| | | 7311 | 45 | -29 | 74 | 39.09 | 34.03 | 8.57 | 36.69 | 150 | 119 | P | V |
| 802.11g CH 11 2462MHz | | 4923 | 41.69 | -32.31 | 74 | 39.75 | 31.67 | 6.92 | 36.65 | 150 | 296 | P | H |
| | | 7386 | 45.31 | -28.69 | 74 | 39.12 | 34.29 | 8.68 | 36.78 | 150 | 185 | P | H |
| | | 4923 | 43.92 | -30.08 | 74 | 41.98 | 31.67 | 6.92 | 36.65 | 150 | 185 | P | V |
| | | 7386 | 45.87 | -28.13 | 74 | 39.68 | 34.29 | 8.68 | 36.78 | 150 | 216 | P | V |
| Remark | 1. No other spurious found. 2. All results are PASS against Peak and Average limit line. | | | | | | | | | | | | |



2.4GHz 2400~2483.5MHz
WIFI 802.11n HT20 (Band Edge @ 3m)

| WIFI Ant. 1 | Note | Frequency (MHz) | Level (dBμV/m) | Over Limit (dB) | Limit Line (dBμV/m) | Read Level (dBμV) | Antenna Factor (dB/m) | Cable Loss (dB) | Preamp Factor (dB) | Ant Pos (cm) | Table Pos (deg) | Peak Avg. (P/A) | Pol. (H/V) |
|-------------------------------|---|-------------------|------------------|-------------------|-----------------------|---------------------|-------------------------|-------------------|----------------------|----------------|-------------------|-------------------|--------------|
| 802.11n HT20 CH 01 2412MHz | * | 2415.948 | 95.71 | - | - | 100.84 | 27.13 | 4.74 | 37 | 150 | 132 | P | H |
| | * | 2416.533 | 84.98 | - | - | 90.11 | 27.13 | 4.74 | 37 | 150 | 132 | A | H |
| | | 2389.74 | 50.54 | -23.46 | 74 | 55.84 | 27 | 4.72 | 37.02 | 150 | 132 | P | H |
| | | 2390 | 33.7 | -20.3 | 54 | 39 | 27 | 4.72 | 37.02 | 150 | 108 | A | H |
| | * | 2416.533 | 101.34 | - | - | 106.47 | 27.13 | 4.74 | 37 | 150 | 97 | P | V |
| | * | 2415.03 | 90.31 | - | - | 95.44 | 27.13 | 4.74 | 37 | 150 | 97 | A | V |
| | | 2389.83 | 54.01 | -19.99 | 74 | 59.31 | 27 | 4.72 | 37.02 | 150 | 97 | P | V |
| | 2389.83 | 36.16 | -17.84 | 54 | 41.46 | 27 | 4.72 | 37.02 | 150 | 97 | A | V | |
| 802.11n HT20 CH 06 2437MHz | * | 2433.817 | 92.95 | - | - | 97.92 | 27.26 | 4.76 | 36.99 | 177 | 133 | P | H |
| | * | 2444.84 | 82.46 | - | - | 87.27 | 27.39 | 4.77 | 36.97 | 177 | 133 | A | H |
| | * | 2442.084 | 98.32 | - | - | 103.13 | 27.39 | 4.77 | 36.97 | 150 | 117 | P | V |
| | * | 2443.253 | 88.09 | - | - | 92.9 | 27.39 | 4.77 | 36.97 | 150 | 117 | A | V |
| 802.11n HT20 CH 11 2462MHz | * | 2454.859 | 97.79 | - | - | 102.45 | 27.51 | 4.79 | 36.96 | 300 | 318 | P | H |
| | * | 2454.609 | 87.69 | - | - | 92.35 | 27.51 | 4.79 | 36.96 | 300 | 318 | A | H |
| | | 2484.64 | 55.83 | -18.17 | 74 | 60.33 | 27.64 | 4.8 | 36.94 | 300 | 318 | P | H |
| | | 2483.52 | 35.2 | -18.8 | 54 | 39.7 | 27.64 | 4.8 | 36.94 | 300 | 318 | A | H |
| | * | 2456.613 | 101.59 | - | - | 106.25 | 27.51 | 4.79 | 36.96 | 150 | 316 | P | V |
| | * | 2455.11 | 90.7 | - | - | 95.36 | 27.51 | 4.79 | 36.96 | 150 | 316 | A | V |
| | | 2483.56 | 57.8 | -16.2 | 74 | 62.3 | 27.64 | 4.8 | 36.94 | 150 | 316 | P | V |
| | 2483.56 | 38.15 | -15.85 | 54 | 42.65 | 27.64 | 4.8 | 36.94 | 150 | 316 | A | V | |
| Remark | 1. No other spurious found. 2. All results are PASS against Peak and Average limit line. | | | | | | | | | | | | |



**2.4GHz 2400~2483.5MHz
WIFI 802.11n HT20 (Harmonic @ 3m)**

| WIFI Ant. 1 | Note | Frequency (MHz) | Level (dBμV/m) | Over Limit (dB) | Limit Line (dBμV/m) | Read Level (dBμV) | Antenna Factor (dB/m) | Cable Loss (dB) | Preamp Factor (dB) | Ant Pos (cm) | Table Pos (deg) | Peak Avg. (P/A) | Pol. (H/V) |
|-------------------------------|---|-------------------|------------------|-------------------|-----------------------|---------------------|-------------------------|-------------------|----------------------|----------------|-------------------|-----------------|------------|
| 802.11n HT20 CH 01 2412MHz | | 4824 | 41.51 | -32.49 | 74 | 39.85 | 31.51 | 6.83 | 36.68 | 162 | 51 | P | H |
| | | 4824 | 42.46 | -31.54 | 74 | 40.8 | 31.51 | 6.83 | 36.68 | 150 | 216 | P | V |
| 802.11n HT20 CH 06 2437MHz | | 4874 | 42.43 | -31.57 | 74 | 40.63 | 31.59 | 6.87 | 36.66 | 150 | 118 | P | H |
| | | 7311 | 46.53 | -27.47 | 74 | 40.62 | 34.03 | 8.57 | 36.69 | 150 | 96 | P | H |
| | | 4874 | 42.74 | -31.26 | 74 | 40.94 | 31.59 | 6.87 | 36.66 | 150 | 332 | P | V |
| | | 7311 | 44.94 | -29.06 | 74 | 39.03 | 34.03 | 8.57 | 36.69 | 150 | 105 | P | V |
| 802.11n HT20 CH 11 2462MHz | | 4923 | 43.84 | -30.16 | 74 | 41.9 | 31.67 | 6.92 | 36.65 | 150 | 316 | P | H |
| | | 7386 | 46.39 | -27.61 | 74 | 40.2 | 34.29 | 8.68 | 36.78 | 150 | 221 | P | H |
| | | 4923 | 43.13 | -30.87 | 74 | 41.19 | 31.67 | 6.92 | 36.65 | 150 | 285 | P | V |
| | | 7386 | 46.94 | -27.06 | 74 | 40.75 | 34.29 | 8.68 | 36.78 | 150 | 169 | P | V |
| Remark | 1. No other spurious found. 2. All results are PASS against Peak and Average limit line. | | | | | | | | | | | | |



Emission below 1GHz
2.4GHz WIFI 802.11g (LF)

| WIFI | Note | Frequency | Level | Over | Limit | Read | Antenna | Cable | Preamp | Ant | Table | Peak | Pol. |
|-------------------------|--|-----------|------------|--------|------------|----------|----------|--------|--------|--------|---------|---------|---------|
| Ant. | | | | Limit | Line | Level | Factor | Loss | Factor | Pos | Pos | Avg. | |
| 1 | | (MHz) | (dBμV/m) | (dB) | (dBμV/m) | (dBμV) | (dB/m) | (dB) | (dB) | (cm) | (deg) | (P/A) | (H/V) |
| 2.4GHz 802.11g LF | | 31.94 | 23.37 | -16.63 | 40 | 39.36 | 18.5 | 0.75 | 35.24 | 145 | 213 | P | H |
| | | 152.22 | 17.11 | -26.39 | 43.5 | 39.32 | 11.13 | 1.59 | 34.93 | - | - | P | H |
| | | 307.42 | 18.58 | -27.42 | 46 | 37.42 | 13.67 | 2.3 | 34.81 | - | - | P | H |
| | | 399.57 | 22.63 | -23.37 | 46 | 39.02 | 16.2 | 2.64 | 35.23 | - | - | P | H |
| | | 684.75 | 23.97 | -22.03 | 46 | 36.08 | 19.21 | 3.52 | 34.84 | - | - | P | H |
| | | 902.03 | 25.5 | -20.5 | 46 | 34.62 | 21.41 | 4.03 | 34.56 | - | - | P | H |
| | | 30 | 28.79 | -11.21 | 40 | 44.18 | 19.1 | 0.73 | 35.22 | 100 | 332 | P | V |
| | | 48.43 | 27.83 | -12.17 | 40 | 52.37 | 9.49 | 0.91 | 34.94 | - | - | P | V |
| | | 140.58 | 13.91 | -29.59 | 43.5 | 35.97 | 11.37 | 1.53 | 34.96 | - | - | P | V |
| | | 498.51 | 16.27 | -29.73 | 46 | 30.59 | 17.29 | 2.95 | 34.56 | - | - | P | V |
| | | 698.33 | 20.92 | -25.08 | 46 | 32.92 | 19.29 | 3.56 | 34.85 | - | - | P | V |
| | | 904.94 | 22.5 | -23.5 | 46 | 31.59 | 21.43 | 4.04 | 34.56 | - | - | P | V |
| Remark | 1. No other spurious found. 2. All results are PASS against limit line. | | | | | | | | | | | | |



Note symbol

| | |
|-----|--|
| * | Fundamental Frequency which can be ignored. However, the level of any unwanted emissions shall not exceed the level of the fundamental frequency. |
| ! | Test result is over limit line. |
| P/A | Peak or Average |
| H/V | Horizontal or Vertical |



A calculation example for radiated spurious emission is shown as below:

| WIFI | Note | Frequency | Level | Over | Limit | Read | Antenna | Cable | Preamp | Ant | Table | Peak | Pol. |
|---------|------|-----------|------------|--------|------------|----------|----------|--------|--------|--------|---------|---------|---------|
| Ant. | | | | Limit | Line | Level | Factor | Loss | Factor | Pos | Pos | Avg. | |
| 1 | | (MHz) | (dBμV/m) | (dB) | (dBμV/m) | (dBμV) | (dB/m) | (dB) | (dB) | (cm) | (deg) | (P/A) | (H/V) |
| 802.11b | | 2390 | 55.45 | -18.55 | 74 | 54.51 | 32.22 | 4.58 | 35.86 | 103 | 308 | P | H |
| CH 01 | | | | | | | | | | | | | |
| 2412MHz | | 2390 | 43.54 | -10.46 | 54 | 42.6 | 32.22 | 4.58 | 35.86 | 103 | 308 | A | H |

- Level(dBμV/m) =
Antenna Factor(dB/m) + Cable Loss(dB) + Read Level(dBμV) - Preamp Factor(dB)
- Over Limit(dB) = Level(dBμV/m) – Limit Line(dBμV/m)

For Peak Limit @ 2390MHz:

- Level(dBμV/m)
= Antenna Factor(dB/m) + Cable Loss(dB) + Read Level(dBμV) - Preamp Factor(dB)
= 32.22(dB/m) + 4.58(dB) + 54.51(dBμV) – 35.86 (dB)
= 55.45 (dBμV/m)
- Over Limit(dB)
= Level(dBμV/m) – Limit Line(dBμV/m)
= 55.45(dBμV/m) – 74(dBμV/m)
= -18.55(dB)

For Average Limit @ 2390MHz:

- Level(dBμV/m)
= Antenna Factor(dB/m) + Cable Loss(dB) + Read Level(dBμV) - Preamp Factor(dB)
= 32.22(dB/m) + 4.58(dB) + 42.6(dBμV) – 35.86 (dB)
= 43.54 (dBμV/m)
- Over Limit(dB)
= Level(dBμV/m) – Limit Line(dBμV/m)
= 43.54(dBμV/m) – 54(dBμV/m)
= -10.46(dB)

Both peak and average measured complies with the limit line, so test result is “PASS”.