

# FCC RF Test Report

APPLICANT : Acer Incorporated  
EQUIPMENT : Smart HandHeld  
BRAND NAME : Acer  
MODEL NAME : Z150  
MARKETING NAME : Liquid Z5  
FCC ID : HLZDMZ150  
STANDARD : FCC 47 CFR Part 2, 22(H), 24(E)  
CLASSIFICATION : PCS Licensed Transmitter Held to Ear (PCE)

The product was received on Nov. 14, 2013 and testing was completed on Nov. 25, 2013. We, SPORTON INTERNATIONAL (KUNSHAN) INC., would like to declare that the tested sample has been evaluated in accordance with the procedures given in ANSI / TIA / EIA-603-C-2004 and shown to be compliant with the applicable technical standards.

The test results in this report apply exclusively to the tested model / sample. Without written approval of SPORTON INTERNATIONAL (KUNSHAN) INC., the test report shall not be reproduced except in full.



Reviewed by: Joseph Lin / Supervisor

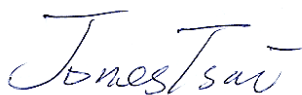

Approved by: Jones Tsai / Manager



**SPORTON INTERNATIONAL (KUNSHAN) INC.**  
**No. 3-2, PingXiang Road, Kunshan, Jiangsu Province, P.R.C.**



# TABLE OF CONTENTS

**REVISION HISTORY..... 3**

**SUMMARY OF TEST RESULT ..... 4**

**1 GENERAL DESCRIPTION ..... 5**

    1.1 Applicant..... 5

    1.2 Manufacturer ..... 5

    1.3 Feature of Equipment Under Test..... 5

    1.4 Product Specification of Equipment Under Test ..... 6

    1.5 Modification of EUT ..... 6

    1.6 Maximum ERP/EIRP Power, Frequency Tolerance, and Emission Designator ..... 7

    1.7 Testing Site ..... 7

    1.8 Applied Standards ..... 8

**2 TEST CONFIGURATION OF EQUIPMENT UNDER TEST ..... 9**

    2.1 Test Mode..... 9

    2.2 Connection Diagram of Test System ..... 12

    2.3 Support Unit used in test configuration and system..... 12

    2.4 Measurement Results Explanation Example ..... 12

**3 TEST RESULT..... 13**

    3.1 Conducted Output Power Measurement..... 13

    3.2 Peak-to-Average Ratio ..... 15

    3.3 Effective Radiated Power and Effective Isotropic Radiated Power Measurement ..... 23

    3.4 99% Occupied Bandwidth and 26dB Bandwidth Measurement..... 29

    3.5 Band Edge Measurement..... 49

    3.6 Conducted Spurious Emission Measurement..... 62

    3.7 Field Strength of Spurious Radiation Measurement ..... 78

    3.8 Frequency Stability Measurement..... 92

**4 LIST OF MEASURING EQUIPMENT ..... 97**

**5 UNCERTAINTY OF EVALUATION ..... 98**

**APPENDIX A. SETUP PHOTOGRAPHS**



### REVISION HISTORY

REPORT NO.	VERSION	DESCRIPTION	ISSUED DATE
FG3N1490	Rev. 01	Initial issue of report	Dec. 12, 2013

## SUMMARY OF TEST RESULT

Report Section	FCC Rule	Description	Limit	Result	Remark
3.1	§2.1046	Conducted Output Power	N/A	PASS	-
3.2	§24.232(d)	Peak-to-Average Ratio	< 13 dB	PASS	-
3.3	§22.913(a)(2)	Effective Radiated Power	< 7 Watts	PASS	-
3.3	§24.232(c)	Equivalent Isotropic Radiated Power	< 2 Watts	PASS	-
3.4	§2.1049 §22.917(a) §24.238(b)	Occupied Bandwidth	N/A	PASS	-
3.5	§2.1051 §22.917(a) §24.238(a)	Band Edge Measurement	< 43+10log <sub>10</sub> (P[Watts])	PASS	-
3.6	§2.1051 §22.917(a) §24.238(a)	Conducted Spurious Emission	< 43+10log <sub>10</sub> (P[Watts])	PASS	-
3.7	§2.1053 §22.917(a) §24.238(a)	Field Strength of Spurious Radiation	< 43+10log <sub>10</sub> (P[Watts])	PASS	Under limit 11.54 dB at 7520.000 MHz
3.8	§2.1055 §22.355 §24.235	Frequency Stability for Temperature & Voltage	< 2.5 ppm	PASS	-



# 1 General Description

## 1.1 Applicant

**Acer Incorporated**

8F., No. 88, Sec. 1, Xintai 5th Rd., Xizhi Dist., New Taipei City 22181, Taiwan (R.O.C)

## 1.2 Manufacturer

**Shanghai Sunrise Simcom Limited**

No. 888, Shengli Rd., Qingpu, Shanghai, P.R.China 201700

## 1.3 Feature of Equipment Under Test

Product Feature	
Equipment	Smart HandHeld
Brand Name	Acer
Model Name	Z150
Marketing Name	Liquid Z5
FCC ID	HLZDMZ150
EUT supports Radios application	GSM/EGPRS/WCDMA/HSPA /HSPA+ (Downlink Only) WLAN2.4GHz 802.11b/g/n HT20/HT40/ Bluetooth v3.0 + EDR/Bluetooth v 4.0
EUT Stage	Identical Prototype

**Remark:** The above EUT's information was declared by manufacturer. Please refer to the specifications or user's manual for more detailed description.

### 1.4 Product Specification of Equipment Under Test

Product Specification subjective to this standard	
<b>Tx Frequency</b>	GSM850: 824.2 MHz ~ 848.8 MHz GSM1900: 1850.2 MHz ~ 1909.8MHz WCDMA Band V: 826.4 MHz ~ 846.6 MHz WCDMA Band II: 1852.4 MHz ~ 1907.6 MHz
<b>Rx Frequency</b>	GSM850: 869.2 MHz ~ 893.8 MHz GSM1900: 1930.2 MHz ~ 1989.8 MHz WCDMA Band V: 871.4 MHz ~ 891.6 MHz WCDMA Band II: 1932.4 MHz ~ 1987.6 MHz
<b>Maximum Output Power to Antenna</b>	GSM850 : 32.39 dBm GSM1900 : 29.21 dBm WCDMA Band V : 22.26 dBm WCDMA Band II : 22.82 dBm
<b>Antenna Type</b>	Monopole Antenna
<b>Type of Modulation</b>	GSM: GMSK GPRS: GMSK EDGE: GMSK / 8PSK WCDMA: QPSK (Uplink) HSDPA: QPSK (Uplink) HSUPA: QPSK (Uplink) HSPA+: 16QAM (Downlink Only)

### 1.5 Modification of EUT

No modifications are made to the EUT during all test items.



### 1.6 Maximum ERP/EIRP Power, Frequency Tolerance, and Emission Designator

FCC Rule	System	Type of Modulation	Maximum ERP/EIRP (W)	Frequency Tolerance (ppm)	Emission Designator
Part 22	GSM850 GSM	GMSK	0.74	0.03 ppm	248KGXW
Part 22	GSM850 EDGE class 8	8PSK	0.29	0.04 ppm	250KG7W
Part 22	WCDMA Band V RMC 12.2Kbps	QPSK	0.17	0.04 ppm	4M20F9W
Part 24	GSM1900 GSM	GMSK	0.90	0.03 ppm	250KGXW
Part 24	GSM1900 EDGE class 8	8PSK	0.47	0.03 ppm	250KG7W
Part 24	WCDMA Band II RMC 12.2Kbps	QPSK	0.18	0.03 ppm	4M18F9W

### 1.7 Testing Site

<b>Test Site</b>	SPORTON INTERNATIONAL (KUNSHAN) INC.		
<b>Test Site Location</b>	No. 3-2, PingXiang Road, Kunshan, Jiangsu Province, P.R.C. TEL: +86-0512-5790-0158 FAX: +86-0512-5790-0958		
<b>Test Site No.</b>	<b>Sporton Site No.</b>		<b>FCC Registration No.</b>
	TH01-KS	03CH01-KS	149928



## 1.8 Applied Standards

According to the specifications of the manufacturer, the EUT must comply with the requirements of the following standards:

- ♦ FCC 47 CFR Part 2, 22(H), 24(E)
- ♦ ANSI / TIA / EIA-603-C-2004
- ♦ FCC KDB 971168 D01 Power Meas. License Digital Systems v02r01

### **Remark:**

1. All test items were verified and recorded according to the standards and without any deviation during the test.
2. This EUT has also been tested and complied with the requirements of FCC Part 15, Subpart B, recorded in a separate test report.



## 2 Test Configuration of Equipment Under Test

### 2.1 Test Mode

During all testing, EUT is in link mode with base station emulator at maximum power level. The spurious emission measurements were carried out in semi-anechoic chamber with 3-meter test range, and EUT was rotated on three test planes to find out the worst emission. (Z Plane for 22H and Y Plane for 24E)

Frequency range investigated for radiated emission is as follows:

1. 30 MHz to 9000 MHz for GSM850 and WCDMA Band V.
2. 30 MHz to 19000 MHz for GSM1900 and WCDMA Band II.

Test Modes		
Band	Radiated TCs	Conducted TCs
GSM 850	<ul style="list-style-type: none"> <li>■ GSM Link</li> <li>■ EDGE class 8 Link</li> </ul>	<ul style="list-style-type: none"> <li>■ GSM Link</li> <li>■ EDGE class 8 Link</li> </ul>
GSM 1900	<ul style="list-style-type: none"> <li>■ GSM Link</li> <li>■ EDGE class 8 Link</li> </ul>	<ul style="list-style-type: none"> <li>■ GSM Link</li> <li>■ EDGE class 8 Link</li> </ul>
WCDMA Band V	<ul style="list-style-type: none"> <li>■ RMC 12.2Kbps Link</li> </ul>	<ul style="list-style-type: none"> <li>■ RMC 12.2Kbps Link</li> </ul>
WCDMA Band II	<ul style="list-style-type: none"> <li>■ RMC 12.2Kbps Link</li> </ul>	<ul style="list-style-type: none"> <li>■ RMC 12.2Kbps Link</li> </ul>

**Note:** The maximum power levels are GSM mode for GMSK link, EDGE multi-slot class 8 mode for 8PSK link, RMC 12.2Kbps mode for WCDMA band V, and RMC 12.2Kbps mode for WCDMA band II, only these modes were used for all tests.



The conducted power tables are as follows:

<SIM1>

Conducted Power (*Unit: dBm)						
Band	GSM850			GSM1900		
Channel	128	189	251	512	661	810
Frequency	824.2	836.4	848.8	1850.2	1880.0	1909.8
GSM	32.37	32.30	32.27	29.19	29.05	29.09
GPRS class 8	32.36	32.31	32.26	29.17	29.04	29.08
GPRS class 10	31.61	31.56	31.49	28.43	28.35	28.38
GPRS class 11	29.83	29.78	29.70	26.65	26.57	26.59
GPRS class 12	28.70	28.67	28.58	25.49	25.42	25.45
EGPRS class 8	27.27	27.08	26.79	25.85	26.08	26.24
EGPRS class 10	26.17	26.00	25.65	24.67	24.90	25.04
EGPRS class 11	23.89	23.70	23.25	22.22	22.40	22.50
EGPRS class 12	22.48	22.29	21.98	20.80	20.90	21.13

Conducted Power (*Unit: dBm)						
Band	WCDMA Band V			WCDMA Band II		
Channel	4132	4182	4233	9262	9400	9538
Frequency	826.4	836.4	846.6	1852.4	1880.0	1907.6
AMR 12.2Kbps	22.18	22.23	21.94	22.78	22.45	21.96
RMC 12.2Kbps	22.21	22.25	21.96	22.80	22.48	22.00
HSDPA Subtest-1	21.40	21.10	21.09	21.07	20.90	20.72
HSDPA Subtest-2	21.38	21.08	21.06	21.05	20.90	20.71
HSDPA Subtest-3	20.94	20.63	20.63	20.60	20.44	20.26
HSDPA Subtest-4	20.92	20.62	20.60	20.58	20.41	20.23
HSUPA Subtest-1	19.50	19.40	19.21	19.60	19.45	19.19
HSUPA Subtest-2	19.48	19.38	19.20	18.97	19.44	19.18
HSUPA Subtest-3	20.47	20.41	20.22	20.10	20.45	20.15
HSUPA Subtest-4	19.08	18.90	18.70	19.50	18.90	18.67
HSUPA Subtest-5	19.92	20.90	20.68	20.05	20.13	20.63



<SIM2>

Conducted Power (*Unit: dBm)						
Band	GSM850			GSM1900		
Channel	128	189	251	512	661	810
Frequency	824.2	836.4	848.8	1850.2	1880.0	1909.8
GSM	32.39	32.31	32.26	29.21	29.07	29.11
GPRS class 8	32.38	32.32	32.25	29.20	29.06	29.10
GPRS class 10	31.62	31.57	31.50	28.45	28.35	28.40
GPRS class 11	29.84	29.79	29.70	26.65	26.59	26.61
GPRS class 12	28.72	28.68	28.60	25.50	25.44	25.47
EGPRS class 8	27.29	27.10	26.78	25.86	26.10	26.26
EGPRS class 10	26.18	26.01	25.67	24.70	24.93	25.05
EGPRS class 11	23.91	23.73	23.28	22.23	22.42	22.51
EGPRS class 12	22.50	22.31	22.00	20.82	20.91	21.15

Conducted Power (*Unit: dBm)						
Band	WCDMA Band V			WCDMA Band II		
Channel	4132	4182	4233	9262	9400	9538
Frequency	826.4	836.4	846.6	1852.4	1880.0	1907.6
AMR 12.2Kbps	22.20	22.24	21.95	22.80	22.46	21.97
RMC 12.2Kbps	22.23	22.26	21.98	22.82	22.50	22.01
HSDPA Subtest-1	21.41	21.12	21.11	21.08	20.91	20.73
HSDPA Subtest-2	21.40	21.11	21.10	21.09	20.90	20.73
HSDPA Subtest-3	20.96	20.65	20.65	20.63	20.45	20.28
HSDPA Subtest-4	20.95	20.64	20.62	20.62	20.42	20.24
HSUPA Subtest-1	19.53	19.42	19.24	19.62	19.46	19.19
HSUPA Subtest-2	19.53	19.42	19.22	18.96	19.46	19.19
HSUPA Subtest-3	20.49	20.40	20.23	20.11	20.48	20.16
HSUPA Subtest-4	19.09	18.91	18.71	19.52	18.90	18.69
HSUPA Subtest-5	19.93	20.89	20.70	20.08	20.14	20.64

## 2.2 Connection Diagram of Test System

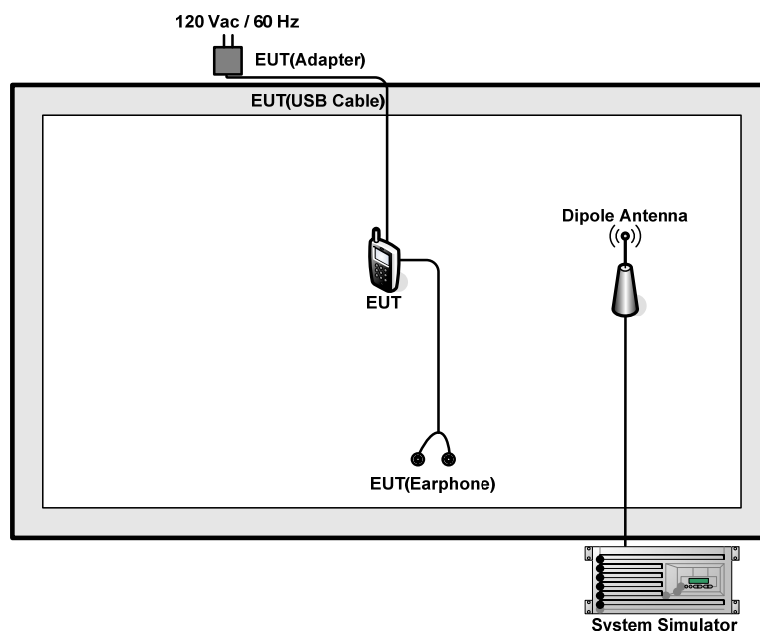

## 2.3 Support Unit used in test configuration and system

Item	Equipment	Trade Name	Model No.	FCC ID	Data Cable	Power Cord
1.	System Simulator	R&S	CMU 200	N/A	N/A	Unshielded, 1.8 m
2.	DC Power Supply	GWINSTEK	GPS-3030D	N/A	N/A	Unshielded, 1.8 m

## 2.4 Measurement Results Explanation Example

### For all conducted test items:

The offset level is set in the spectrum analyzer to compensate the RF cable loss and attenuator factor between EUT conducted output port and spectrum analyzer. With the offset compensation, the spectrum analyzer reading level is exactly the EUT RF output level.

The spectrum analyzer offset is derived from RF cable loss and attenuator factor.

*Offset = RF cable loss + attenuator factor.*

Following shows an offset computation example with cable loss 5.2 dB and 10dB attenuator.

Example :

$$\begin{aligned} \text{Offset(dB)} &= \text{RF cable loss(dB)} + \text{attenuator factor(dB)}. \\ &= 5.2 + 10 = 15.2 \text{ (dB)} \end{aligned}$$

### 3 Test Result

#### 3.1 Conducted Output Power Measurement

##### 3.1.1 Description of the Conducted Output Power Measurement

A base station simulator was used to establish communication with the EUT. Its parameters were set to transmit the maximum power on the EUT. The measured power in the radio frequency on the transmitter output terminals shall be reported.

##### 3.1.2 Measuring Instruments

The measuring equipment is listed in the section 4 of this test report.

##### 3.1.3 Test Procedures

1. The transmitter output port was connected to base station.
2. Set EUT at maximum power through base station.
3. Select lowest, middle, and highest channels for each band and different modulation.
4. Measure the maximum burst average power for GSM and maximum average power for other modulation signal.

##### 3.1.4 Test Setup

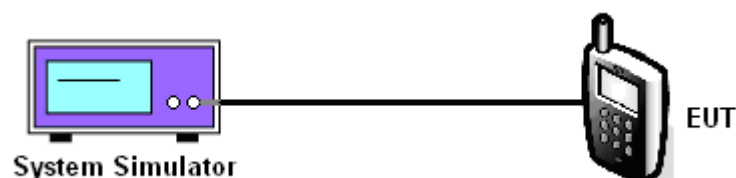

3.1.5 Test Result of Conducted Output Power

Cellular Band									
Modes	GSM850 (GSM)			GSM850 (EDGE class 8)			WCDMA Band V (RMC 12.2Kbps)		
Channel	128 (Low)	189 (Mid)	251 (High)	128 (Low)	189 (Mid)	251 (High)	4132 (Low)	4182 (Mid)	4233 (High)
Frequency (MHz)	824.2	836.4	848.8	824.2	836.4	848.8	826.4	836.4	846.6
Conducted Power (dBm)	32.39	32.31	32.26	27.29	27.10	26.78	22.23	22.26	21.98
Conducted Power (Watts)	1.73	1.70	1.68	0.54	0.51	0.48	0.17	0.17	0.16

PCS Band									
Modes	GSM1900 (GSM)			GSM1900 (EDGE class 8)			WCDMA Band II (RMC 12.2Kbps)		
Channel	512 (Low)	661 (Mid)	810 (High)	512 (Low)	661 (Mid)	810 (High)	9262 (Low)	9400 (Mid)	9538 (High)
Frequency (MHz)	1850.2	1880	1909.8	1850.2	1880	1909.8	1852.4	1880	1907.6
Conducted Power (dBm)	29.21	29.07	29.11	25.86	26.10	26.26	22.82	22.50	22.01
Conducted Power (Watts)	0.83	0.81	0.81	0.39	0.41	0.42	0.19	0.18	0.16

**Note:** maximum burst average power for GSM, and maximum average power for WCDMA.

## 3.2 Peak-to-Average Ratio

### 3.2.1 Description of the PAR Measurement

The peak-to-average ratio (PAR) of the transmission may not exceed 13 dB.

### 3.2.2 Measuring Instruments

The measuring equipment is listed in the section 4 of this test report.

### 3.2.3 Test Procedures

1. The EUT was connected to Spectrum Analyzer and System Simulator via power divider.
2. For GSM/EGPRS operating modes:
  - a. Set EUT in maximum power output.
  - b. Set the RBW = 1MHz, VBW = 3MHz, Peak detector in spectrum analyzer for first trace.
  - c. Set the RBW = 1MHz, VBW = 3MHz, RMS detector in spectrum analyzer for second trace.
  - d. The wanted burst signal is triggered by spectrum analyzer, and measured respectively the peak level and Mean level without burst-off time, after system simulator synchronized with the spectrum analyzer.
3. For UMTS operating modes:
  - a. Set the CCDF (Complementary Cumulative Distribution Function) option in spectrum analyzer.
  - b. The highest RF powers were measured and recorded the maximum PAPR level associated with a probability of 0.1 %.
4. Record the deviation as Peak to Average Ratio.

### 3.2.4 Test Setup

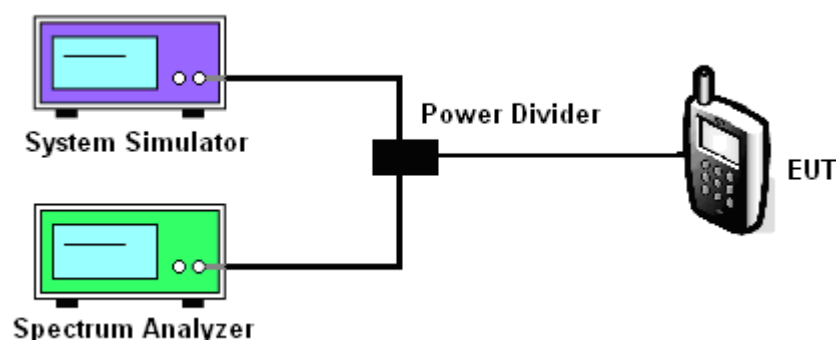



3.2.5 Test Result of Peak-to-Average Ratio

PCS Band									
Modes	GSM1900 (GSM)			GSM1900 (EDGE class 8)			WCDMA Band II (RMC 12.2Kbps)		
Channel	512 (Low)	661 (Mid)	810 (High)	512 (Low)	661 (Mid)	810 (High)	9262 (Low)	9400 (Mid)	9538 (High)
Frequency (MHz)	1850.2	1880	1909.8	1850.2	1880	1909.8	1852.4	1880	1907.6
Peak-to-Average Ratio (dB)	0.27	0.28	0.28	2.64	2.56	2.49	2.96	3.16	2.88





### 3.2.6 Test Result (Plots) of Peak-to-Average Ratio

Band :	GSM 1900	Test Mode :	GSM Link (GMSK)
--------	----------	-------------	-----------------

Peak-to-Average Ratio on Channel 512 (1850.2 MHz)

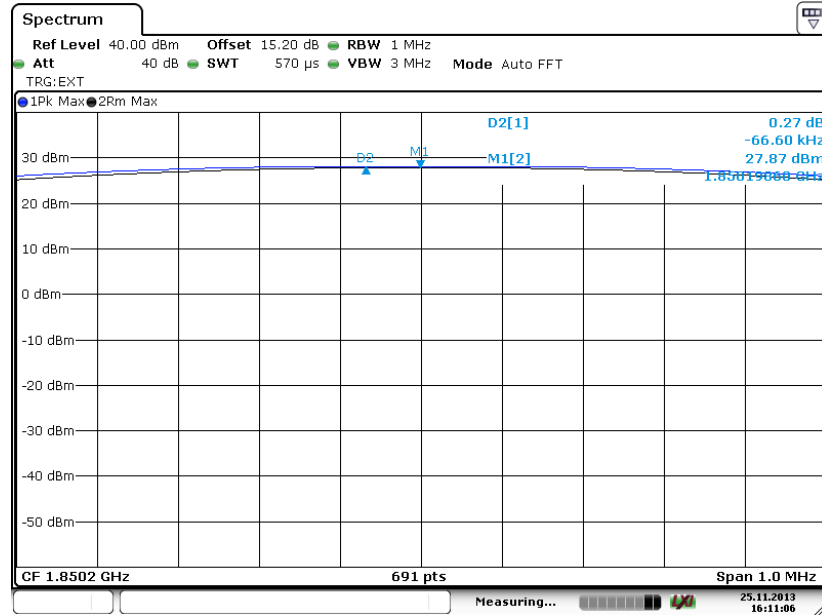

Date: 25 NOV. 2013 16:11:06

Peak-to-Average Ratio on Channel 661 (1880.0 MHz)

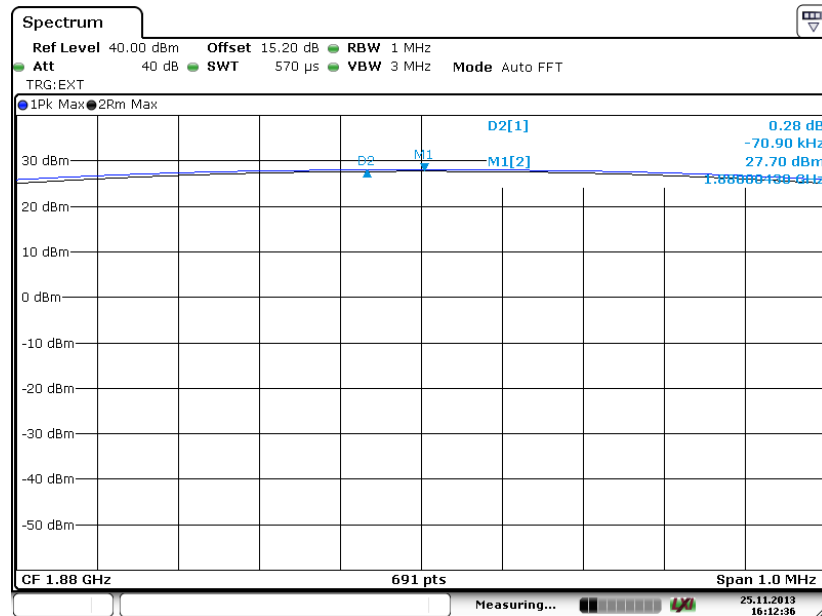

Date: 25 NOV. 2013 16:12:36



Peak-to-Average Ratio on Channel 810 (1909.8 MHz)

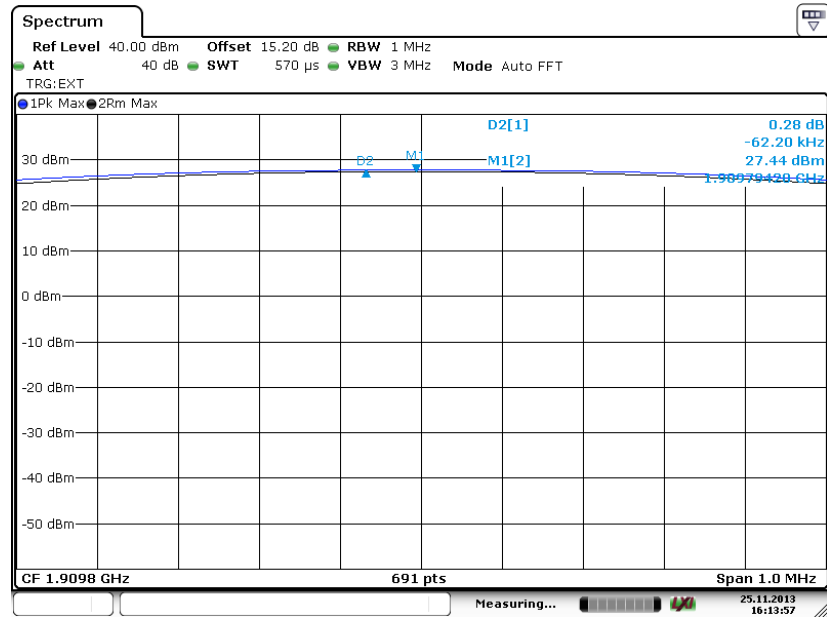

Date: 25 NOV. 2013 16:13:57



Band :	GSM 1900	Test Mode :	EDGE class 8 Link (8PSK)
--------	----------	-------------	--------------------------

Peak-to-Average Ratio on Channel 512 (1850.2 MHz)

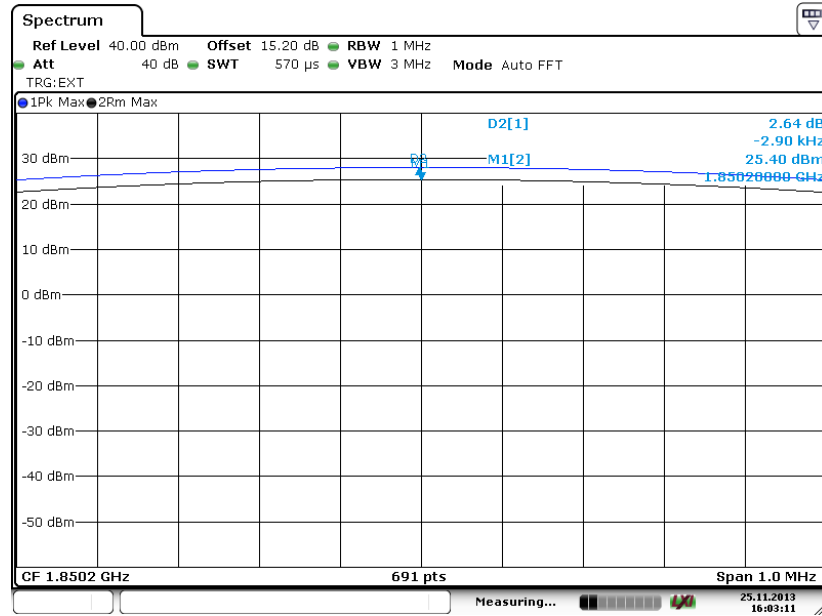

Date: 25 NOV 2013 16:03:11

Peak-to-Average Ratio on Channel 661 (1880.0 MHz)

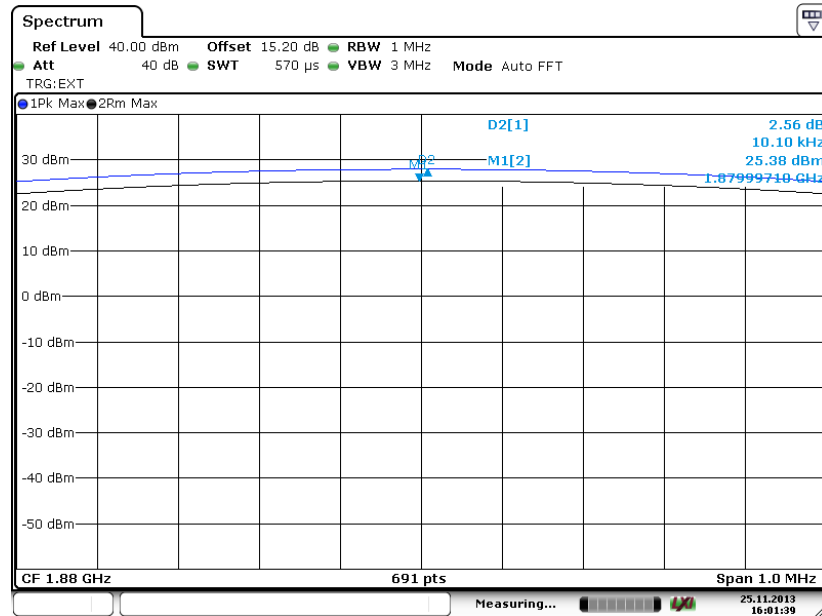

Date: 25 NOV 2013 16:01:38



Peak-to-Average Ratio on Channel 810 (1909.8 MHz)

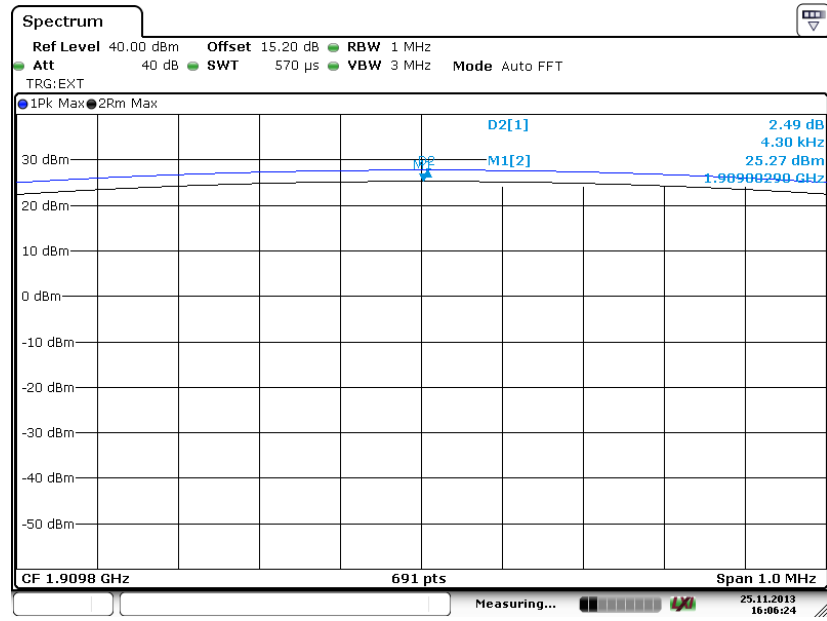

Date : 25 NOV 2013 16:06:24



<b>Band :</b>	WCDMA Band II	<b>Test Mode :</b>	RMC 12.2Kbps Link (QPSK)
---------------	---------------	--------------------	--------------------------

**Peak-to-Average Ratio on Channel 9262 (1852.4 MHz)**

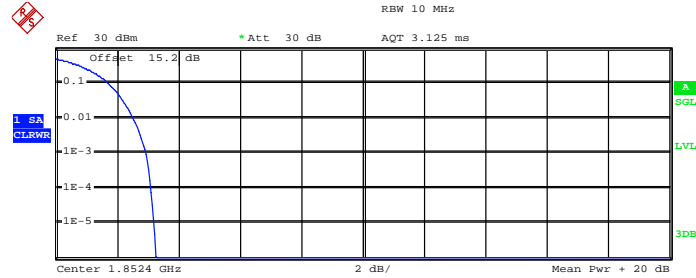

Complementary Cumulative Distribution Function (100000 samples)

Trace 1  
 Mean 18.83 dBm  
 Peak 22.09 dBm  
 Crest 3.27 dB

10 % 1.72 dB  
 1 % 2.52 dB  
 .1 % 2.96 dB  
 .01 % 3.12 dB

**Peak-to-Average Ratio on Channel 9400 (1880.0 MHz)**

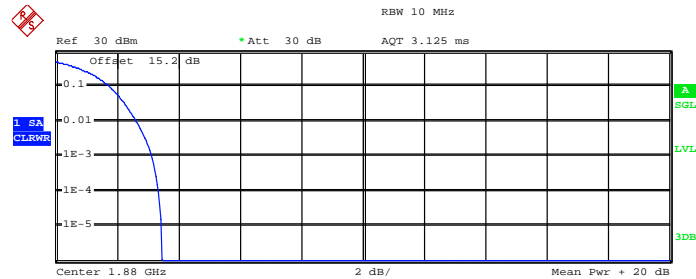

Complementary Cumulative Distribution Function (100000 samples)

Trace 1  
 Mean 18.28 dBm  
 Peak 21.74 dBm  
 Crest 3.46 dB

10 % 1.76 dB  
 1 % 2.64 dB  
 .1 % 3.16 dB  
 .01 % 3.36 dB



Peak-to-Average Ratio on Channel 9538 (1907.6 MHz)

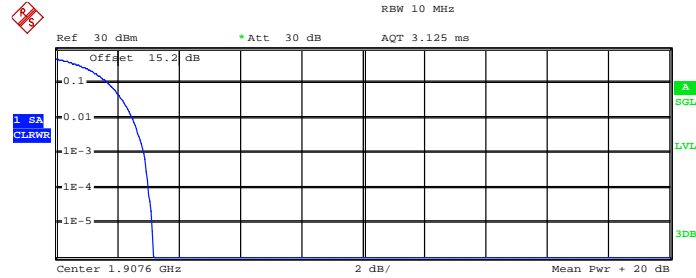

Complementary Cumulative Distribution Function (100000 samples)

Trace 1  
Mean 17.02 dBm  
Peak 20.19 dBm  
Crest 3.17 dB  
  
10 % 1.72 dB  
1 % 2.52 dB  
.1 % 2.88 dB  
.01 % 3.04 dB

### 3.3 Effective Radiated Power and Effective Isotropic Radiated Power Measurement

#### 3.3.1 Description of the ERP/EIRP Measurement

The substitution method, in ANSI / TIA / EIA-603-C-2004, was used for ERP/EIRP measurement, and the spectrum analyzer configuration follows KDB 971168 D01 Power Meas. License Digital Systems v02r01. The ERP of mobile transmitters must not exceed 7 Watts and the EIRP of mobile transmitters are limited to 2 Watts.

#### 3.3.2 Measuring Instruments

The measuring equipment is listed in the section 4 of this test report.

#### 3.3.3 Test Procedures

1. The EUT was placed on a non-conductive rotating platform with 0.8 meter height in a semi-anechoic chamber. The radiated emission at the fundamental frequency was measured at 3 m with a test antenna and a spectrum analyzer with RBW= 1MHz, VBW= 3MHz for GSM, RBW= 100 kHz, VBW= 300 kHz, used channel power option with bandwidth=5MHz for WCDMA, and RMS detector settings per KDB 971168 D01.
2. During the measurement, the EUT was enforced in maximum power and linked with a base station. The highest emission was recorded from analyzer power level (LVL) from the 360 degrees rotation of the turntable and the test antenna raised and lowered over a range from 1 to 4 meters in both horizontally and vertically polarized orientations.
3. Effective Isotropic Radiated Power (EIRP) was measured by substitution method according to TIA/EIA-603-C. The EUT was replaced by dipole antenna (substitution antenna) at same location, and then a known power from S.G. was applied into the dipole antenna through a Tx cable, and then recorded the maximum Analyzer reading through raised and lowered the test antenna. The correction factor (in dB) = S.G. - Tx Cable loss + Substitution antenna gain - Analyzer reading. Then the EUT's EIRP was calculated with the correction factor,  $EIRP = LVL + \text{Correction factor}$  and  $ERP = EIRP - 2.15$ .

### 3.3.4 Test Setup

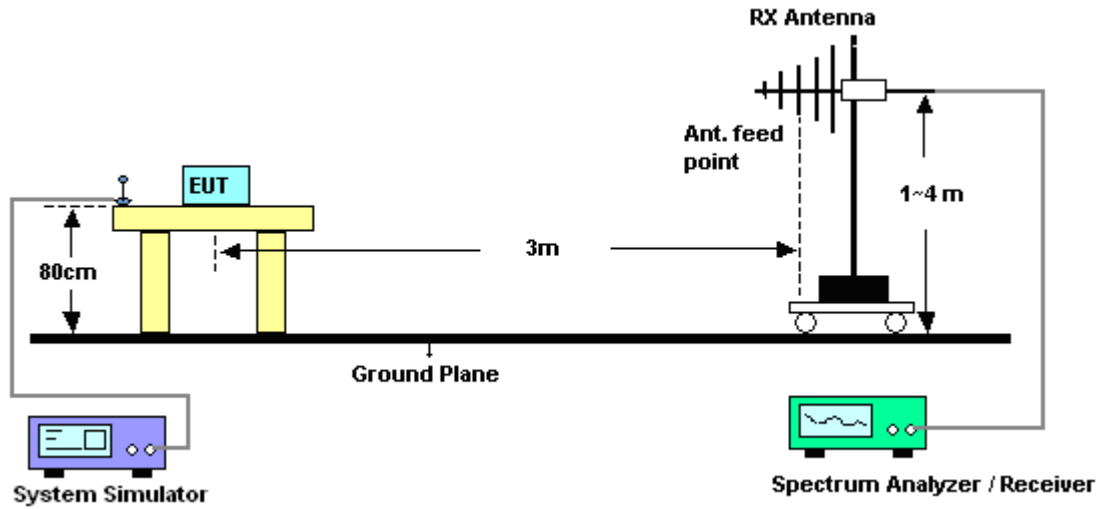



3.3.5 Test Result of ERP

GSM850 (GSM) Radiated Power ERP				
Horizontal Polarization				
Frequency (MHz)	LVL (dBm)	Correction Factor (dB)	ERP (dBm)	ERP (W)
824.2	-0.32	29.11	26.64	0.46
836.4	1.62	29.2	28.67	0.74
848.8	0.41	29.4	27.66	0.58
Vertical Polarization				
Frequency (MHz)	LVL (dBm)	Correction Factor (dB)	ERP (dBm)	ERP (W)
824.2	-10.64	33.23	20.44	0.11
836.4	-10.86	33	19.99	0.10
848.8	-10.25	32.95	20.55	0.11

\* ERP = LVL (dBm) + Correction Factor (dB) – 2.15

GSM850 (EDGE class 8) Radiated Power ERP				
Horizontal Polarization				
Frequency (MHz)	LVL (dBm)	Correction Factor (dB)	ERP (dBm)	ERP (W)
824.2	-12.47	29.11	14.49	0.03
836.4	-12.61	29.2	14.44	0.03
848.8	-12.57	29.4	14.68	0.03
Vertical Polarization				
Frequency (MHz)	LVL (dBm)	Correction Factor (dB)	ERP (dBm)	ERP (W)
824.2	-8.01	33.23	23.07	0.20
836.4	-6.24	33	24.61	0.29
848.8	-7.01	32.95	23.79	0.24

\* ERP = LVL (dBm) + Correction Factor (dB) – 2.15



WCDMA Band V (RMC 12.2Kbps) Radiated Power ERP				
Horizontal Polarization				
Frequency (MHz)	LVL (dBm)	Correction Factor (dB)	ERP (dBm)	ERP (W)
826.40	-5.52	29.11	21.44	0.14
836.40	-6.32	29.2	20.73	0.12
846.60	-5.07	29.4	22.18	0.17
Vertical Polarization				
Frequency (MHz)	LVL (dBm)	Correction Factor (dB)	ERP (dBm)	ERP (W)
826.40	-17.36	33.23	13.72	0.02
836.40	-17.68	33	13.17	0.02
846.60	-17.69	32.95	13.11	0.02

\* ERP = LVL (dBm) + Correction Factor (dB) – 2.15

3.3.6 Test Result of EIRP

GSM1900 (GSM) Radiated Power EIRP				
Horizontal Polarization				
Frequency (MHz)	LVL (dBm)	Correction Factor (dB)	EIRP (dBm)	EIRP (W)
1850.2	-14.39	42.76	28.37	0.69
1880.0	-12.79	42.32	29.53	0.90
1909.8	-13.68	41.95	28.27	0.67
Vertical Polarization				
Frequency (MHz)	LVL (dBm)	Correction Factor (dB)	EIRP (dBm)	EIRP (W)
1850.2	-22.04	42.13	20.09	0.10
1880.0	-21.56	42.79	21.23	0.13
1909.8	-20.80	42.83	22.03	0.16

\* EIRP = LVL (dBm) + Correction Factor (dB)

GSM1900 (EDGE class 8) Radiated Power EIRP				
Horizontal Polarization				
Frequency (MHz)	LVL (dBm)	Correction Factor (dB)	EIRP (dBm)	EIRP (W)
1850.2	-16.01	42.76	26.75	0.47
1880.0	-16.21	42.32	26.11	0.41
1909.8	-15.27	41.95	26.68	0.47
Vertical Polarization				
Frequency (MHz)	LVL (dBm)	Correction Factor (dB)	EIRP (dBm)	EIRP (W)
1850.2	-21.08	42.13	21.05	0.13
1880.0	-23.22	42.79	19.57	0.09
1909.8	-21.85	42.83	20.98	0.13

\* EIRP = LVL (dBm) + Correction Factor (dB)



WCDMA Band II (RMC 12.2Kbps) Radiated Power EIRP				
Horizontal Polarization				
Frequency (MHz)	LVL (dBm)	Correction Factor (dB)	EIRP (dBm)	EIRP (W)
1852.40	-20.45	42.76	22.31	0.17
1880.00	-20.10	42.32	22.22	0.17
1907.60	-19.51	41.95	22.44	0.18
Vertical Polarization				
Frequency (MHz)	LVL (dBm)	Correction Factor (dB)	EIRP (dBm)	EIRP (W)
1852.40	-26.52	42.13	15.61	0.04
1880.00	-27.40	42.79	15.39	0.03
1907.60	-26.16	42.83	16.67	0.05

\* EIRP = LVL (dBm) + Correction Factor (dB)

## 3.4 99% Occupied Bandwidth and 26dB Bandwidth Measurement

### 3.4.1 Description of 99% Occupied Bandwidth and 26dB Bandwidth Measurement

The 99% occupied bandwidth is the width of a frequency band such that, below the lower and above the upper frequency limits, the mean powers emitted are each equal to a specified percentage 0.5% of the total mean transmitted power.

The emission bandwidth is defined as the width of the signal between two points, located at the 2 sides of the carrier frequency, outside of which all emissions are attenuated at least 26 dB below the transmitter power.

### 3.4.2 Measuring Instruments

The measuring equipment is listed in the section 4 of this test report.

### 3.4.3 Test Procedures

1. The EUT was connected to Spectrum Analyzer and Base Station via power divider.
2. The RF output of EUT was connected to the spectrum analyzer by RF cable and attenuator. The path loss was compensated to the results for each measurement.
3. The 99% occupied bandwidth were measured, set RBW= 1% of span, VBW= 3\*RBW, sample detector, trace maximum hold.
4. The 26dB bandwidth were measured, set RBW= 1% of EBW, VBW= 3\*RBW, peak detector, trace maximum hold.

### 3.4.4 Test Setup

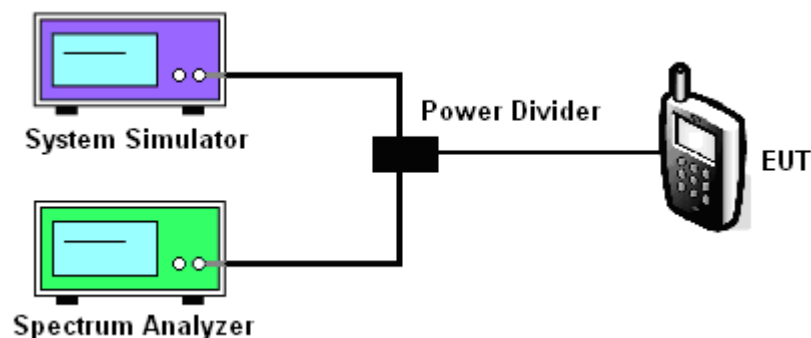

3.4.5 Test Result of Occupied Bandwidth and 26dB Bandwidth

Cellular Band						
Modes	GSM850 (GSM)			GSM850 (EDGE class 8)		
Channel	128 (Low)	189 (Mid)	251 (High)	128 (Low)	189 (Mid)	251 (High)
Frequency (MHz)	824.2	836.4	848.8	824.2	836.4	848.8
99% OBW (kHz)	246.00	248.00	248.00	250.00	248.00	250.00
26dB BW (kHz)	310.00	306.00	312.00	320.00	318.00	314.00

PCS Band						
Modes	GSM1900 (GSM)			GSM1900 (EDGE class 8)		
Channel	512 (Low)	661 (Mid)	810 (High)	512 (Low)	661 (Mid)	810 (High)
Frequency (MHz)	1850.2	1880	1909.8	1850.2	1880	1909.8
99% OBW (kHz)	244.00	250.00	248.00	250.00	236.00	246.00
26dB BW (kHz)	308.00	310.00	312.00	316.00	316.00	318.00

Cellular Band			
Modes	WCDMA Band V (RMC 12.2Kbps)		
Channel	4132 (Low)	4182 (Mid)	4233 (High)
Frequency (MHz)	826.4	836.4	846.6
99% OBW (MHz)	4.160	4.200	4.180
26dB BW (MHz)	4.700	4.720	4.680

PCS Band			
Modes	WCDMA Band II (RMC 12.2Kbps)		
Channel	9262 (Low)	9400 (Mid)	9538 (High)
Frequency (MHz)	1852.4	1880	1907.6
99% OBW (MHz)	4.180	4.180	4.180
26dB BW (MHz)	4.680	4.680	4.700

### 3.4.6 Test Result (Plots) of Occupied Bandwidth and 26dB Bandwidth

Band :	GSM 850	Test Mode :	GSM Link (GMSK)
--------	---------	-------------	-----------------

99% Occupied Bandwidth Plot on Channel 128 (824.2 MHz)

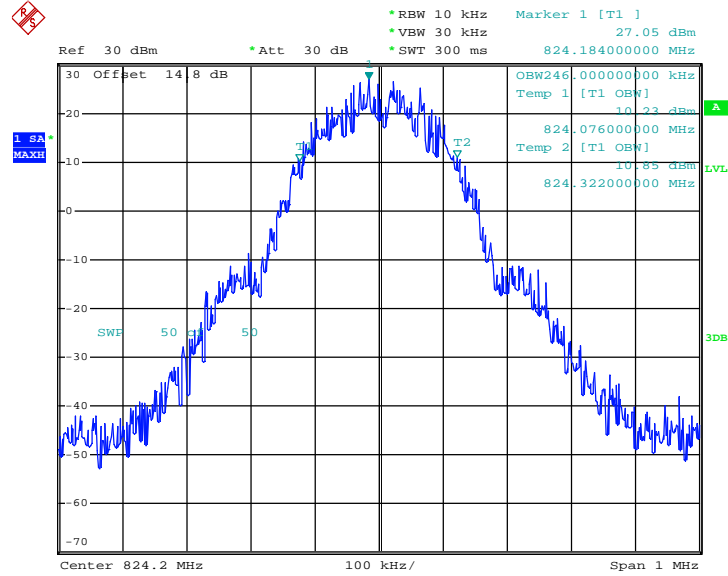

26dB Bandwidth Plot on Channel 128 (824.2 MHz)

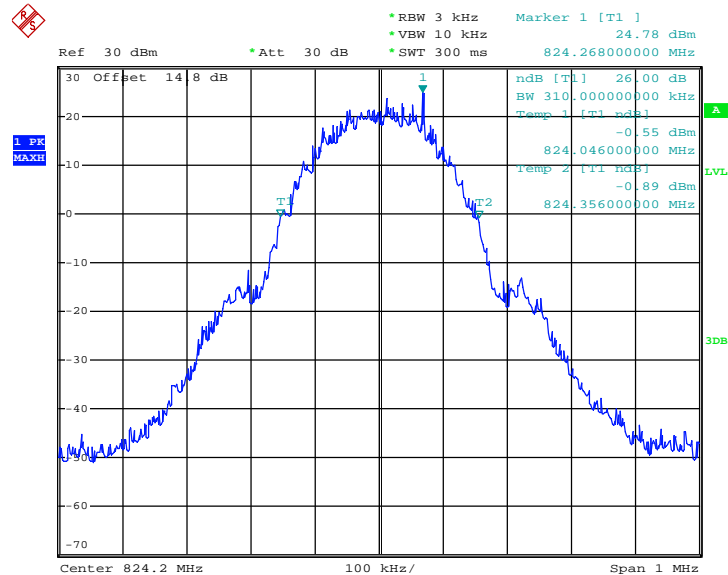



99% Occupied Bandwidth Plot on Channel 189 (836.4 MHz)

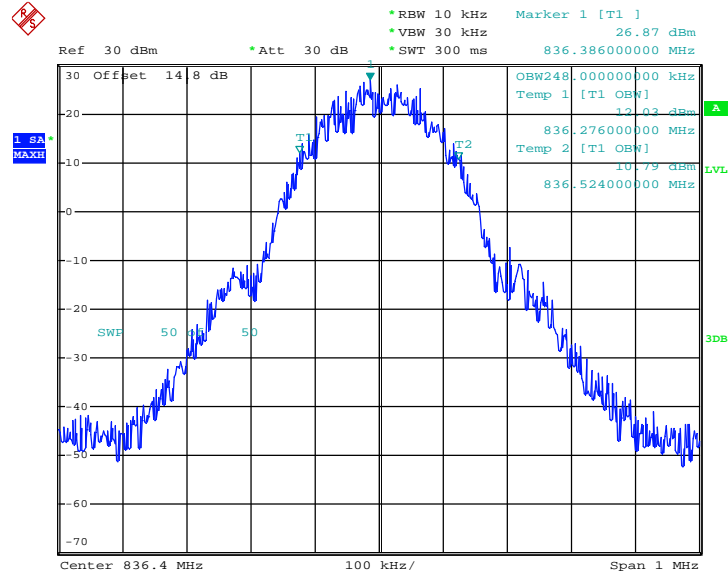

26dB Bandwidth Plot on Channel 189 (836.4 MHz)

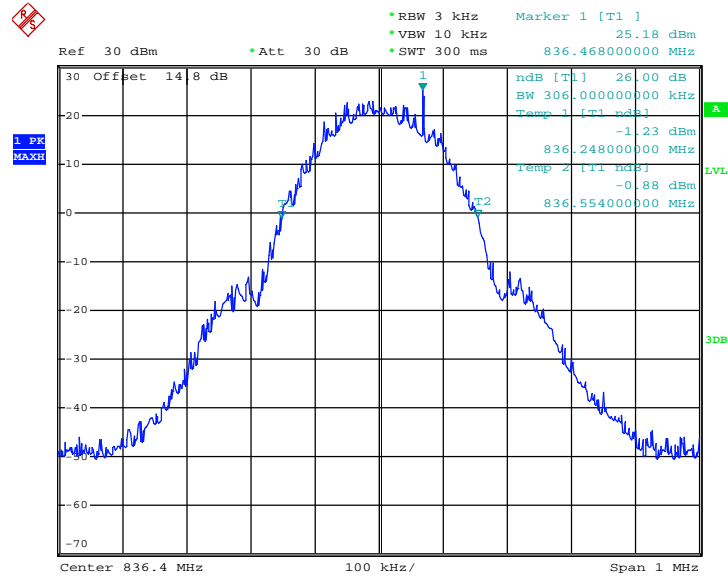





99% Occupied Bandwidth Plot on Channel 251 (848.8 MHz)

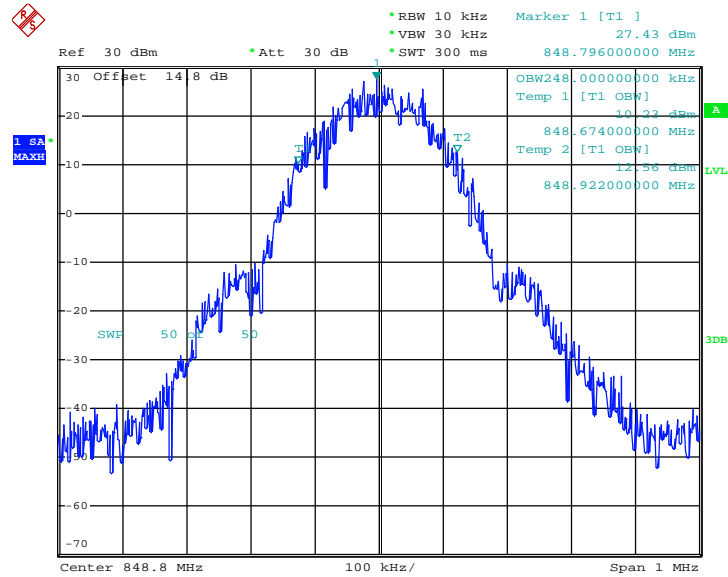

26dB Bandwidth Plot on Channel 251 (848.8 MHz)

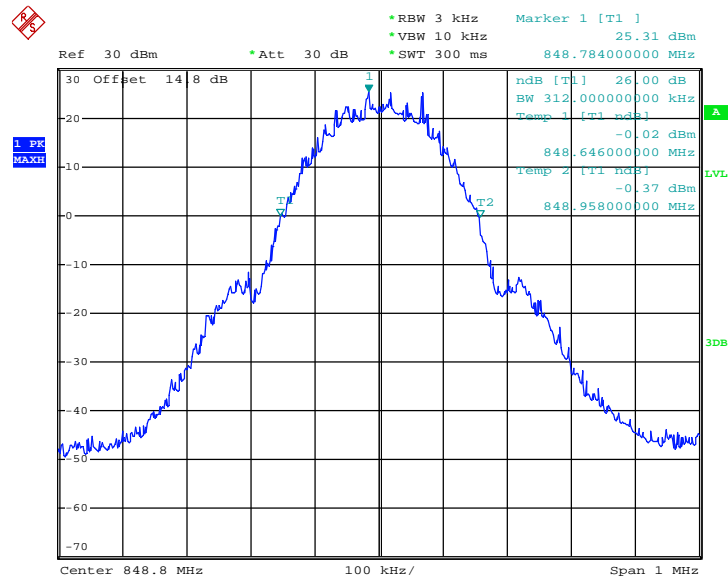



Band :	GSM 850	Test Mode :	EDGE class 8 Link (8PSK)
--------	---------	-------------	--------------------------

99% Occupied Bandwidth Plot on Channel 128 (824.2 MHz)

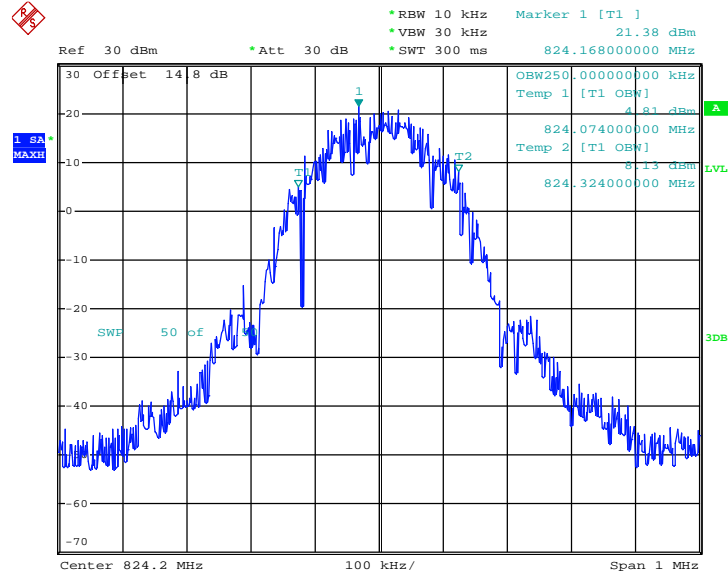

26dB Bandwidth Plot on Channel 128 (824.2 MHz)

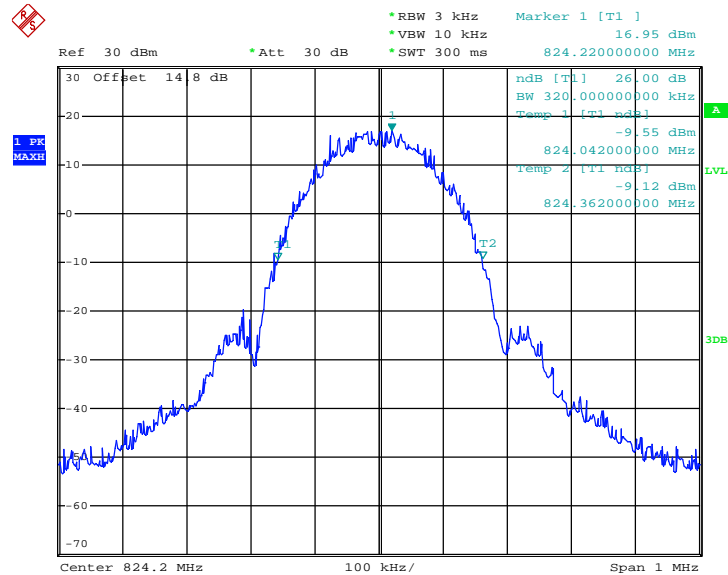



99% Occupied Bandwidth Plot on Channel 189 (836.4 MHz)

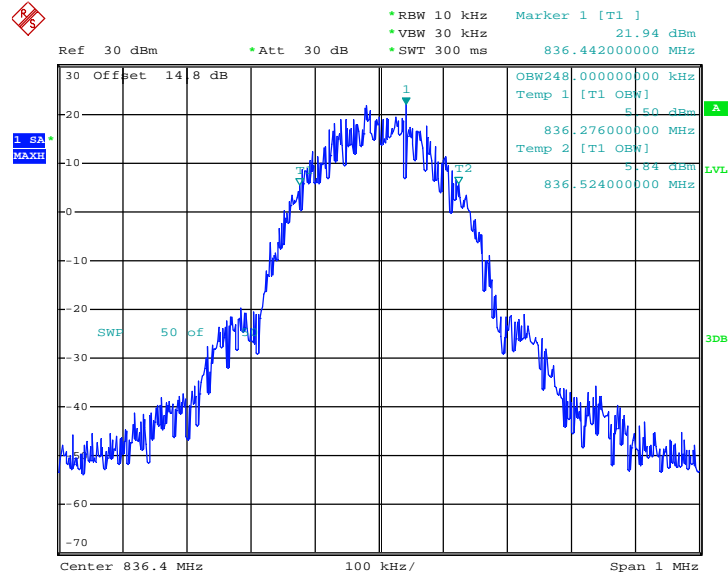

26dB Bandwidth Plot on Channel 189 (836.4 MHz)

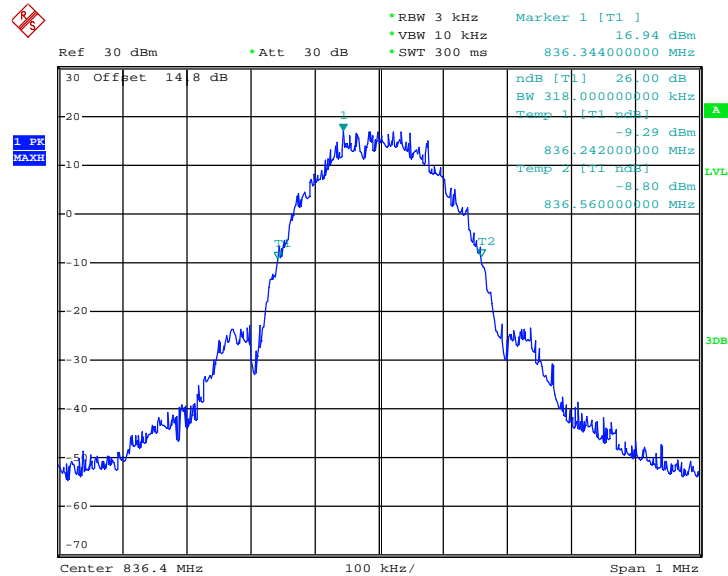



99% Occupied Bandwidth Plot on Channel 251 (848.8 MHz)

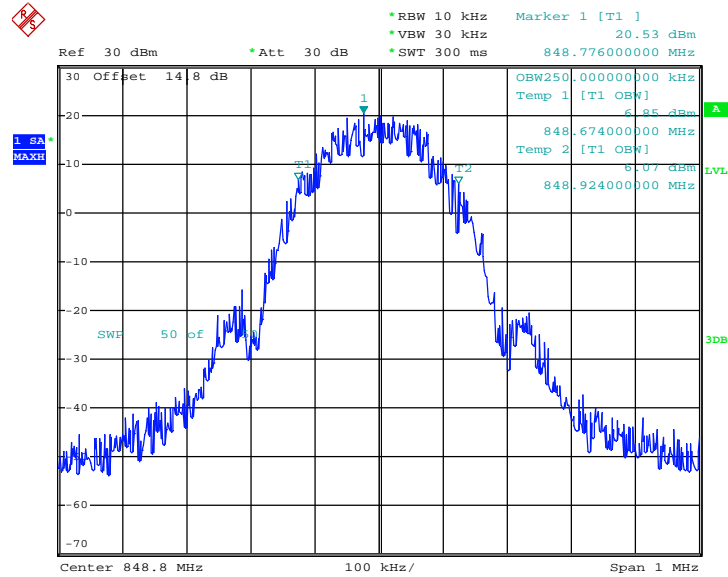

26dB Bandwidth Plot on Channel 251 (848.8 MHz)

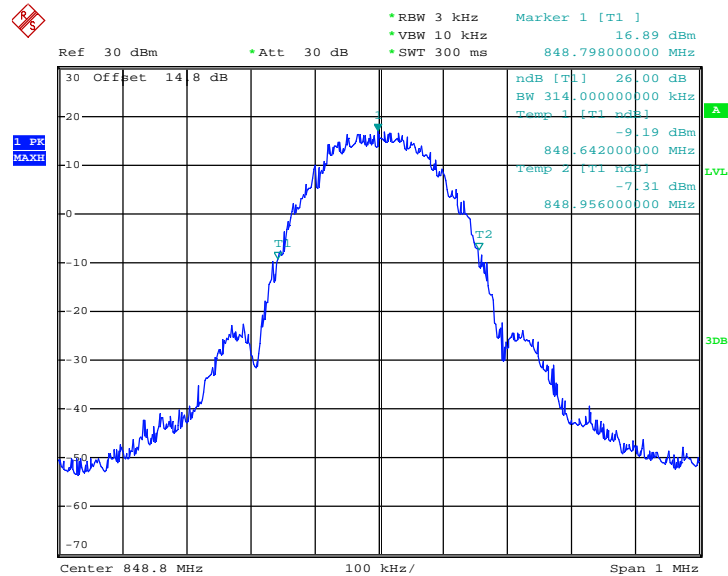



Band :	GSM 1900	Test Mode :	GSM Link (GMSK)
--------	----------	-------------	-----------------

99% Occupied Bandwidth Plot on Channel 512 (1850.2 MHz)

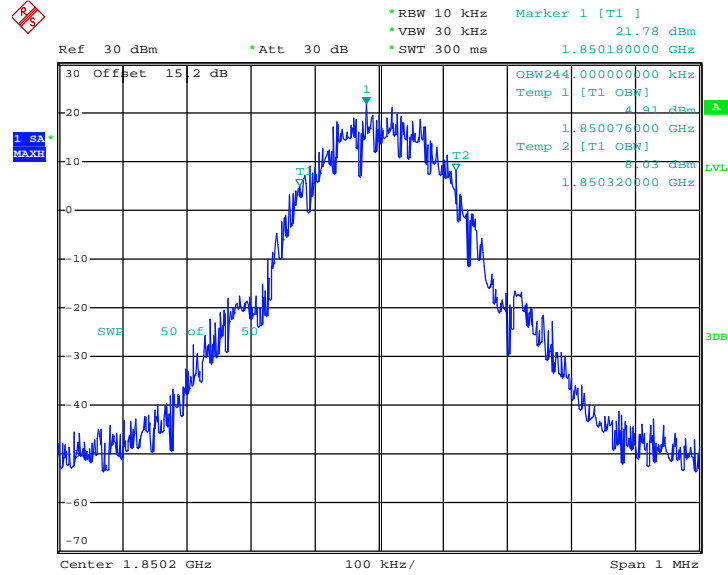

26dB Bandwidth Plot on Channel 512 (1850.2 MHz)

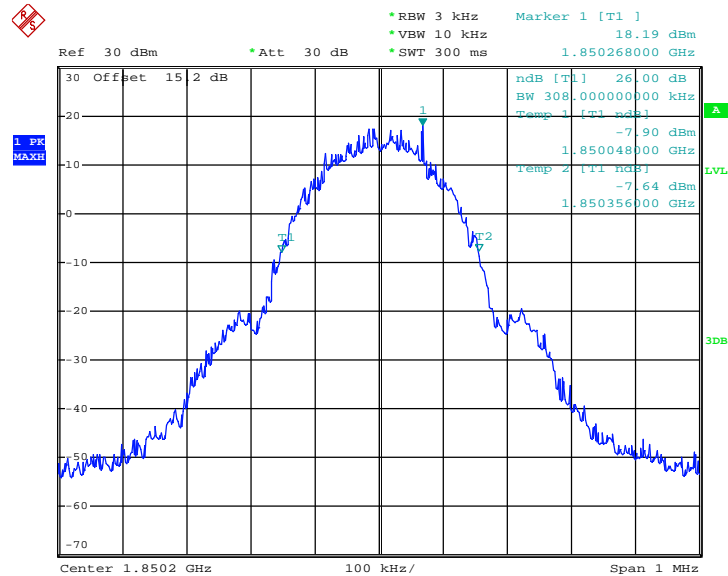



99% Occupied Bandwidth Plot on Channel 661 (1880.0 MHz)

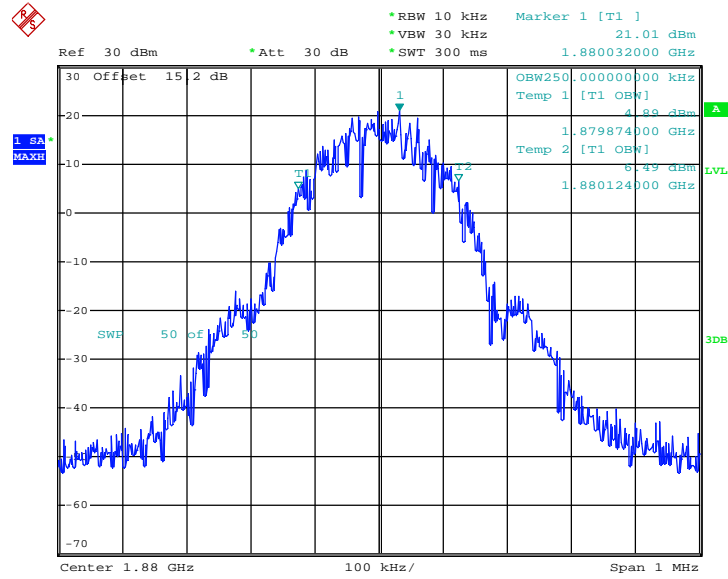

26dB Bandwidth Plot on Channel 661 (1880.0 MHz)

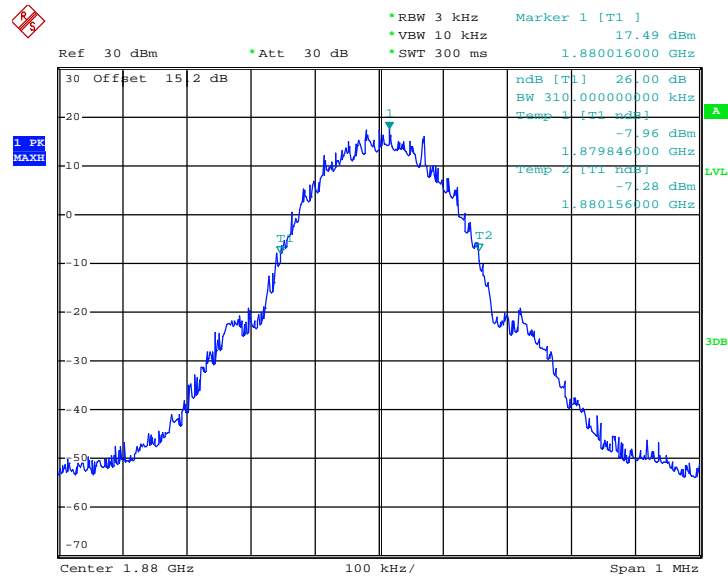



99% Occupied Bandwidth Plot on Channel 810 (1909.8 MHz)

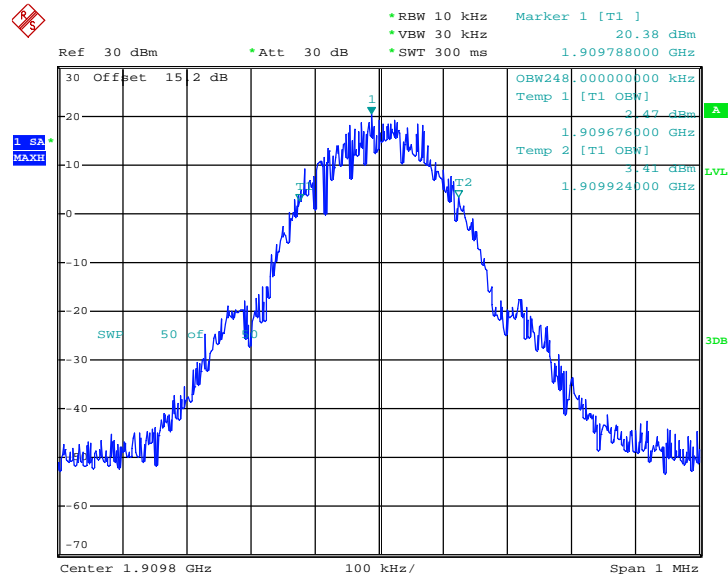

26dB Bandwidth Plot on Channel 810 (1909.8 MHz)

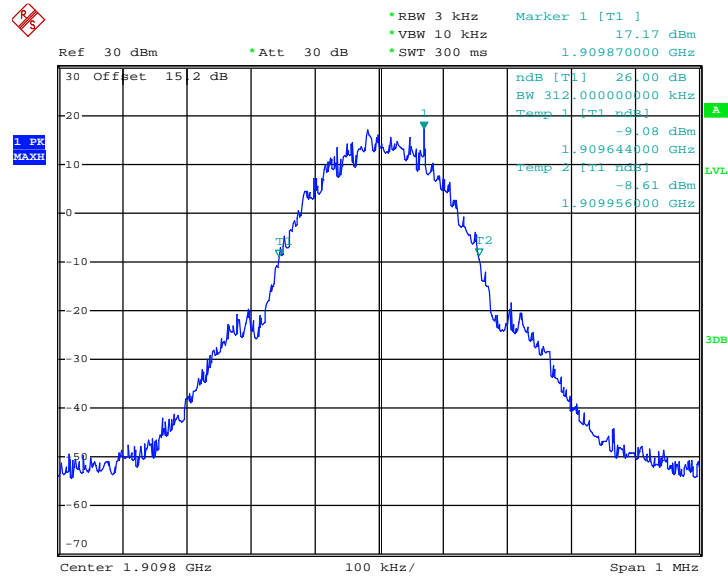



Band :	GSM 1900	Test Mode :	EDGE class 8 Link (8PSK)
--------	----------	-------------	--------------------------

99% Occupied Bandwidth Plot on Channel 512 (1850.2 MHz)

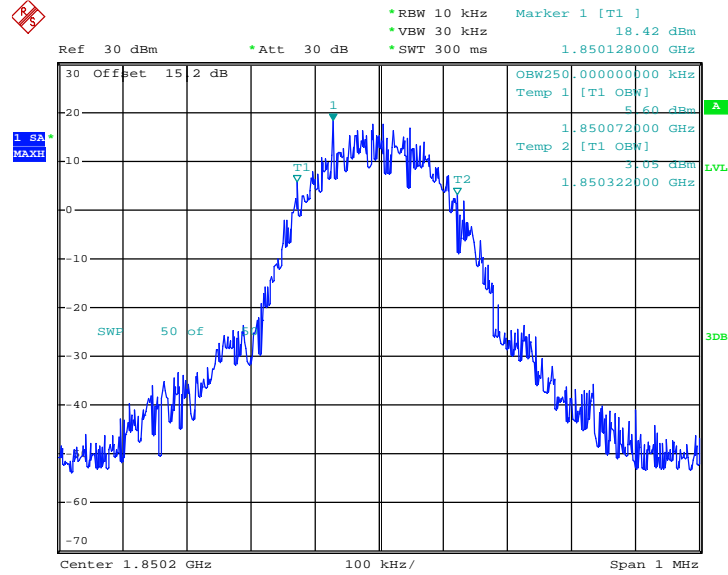

26dB Bandwidth Plot on Channel 512 (1850.2 MHz)

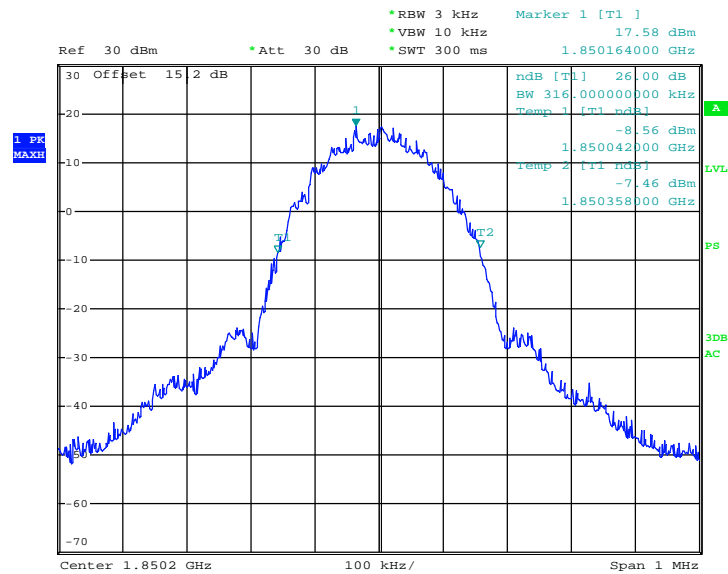

Date: 25.NOV.2013 23:01:48





99% Occupied Bandwidth Plot on Channel 661 (1880.0 MHz)

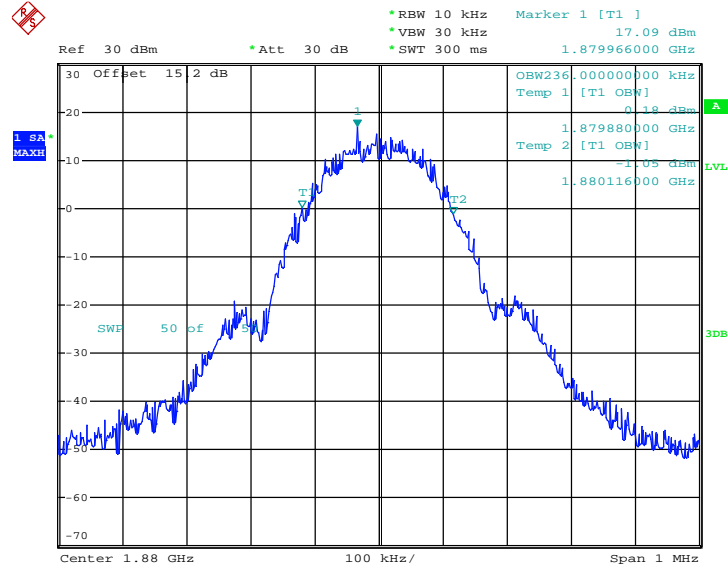

26dB Bandwidth Plot on Channel 661 (1880.0 MHz)

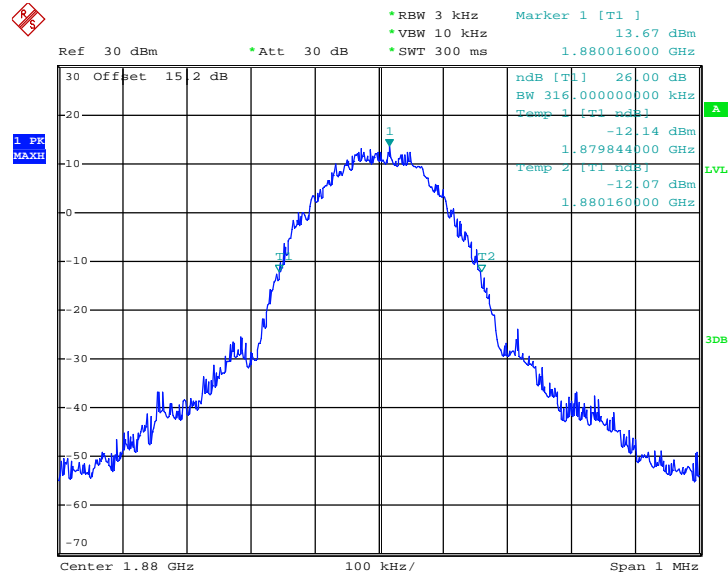



99% Occupied Bandwidth Plot on Channel 810 (1909.8 MHz)

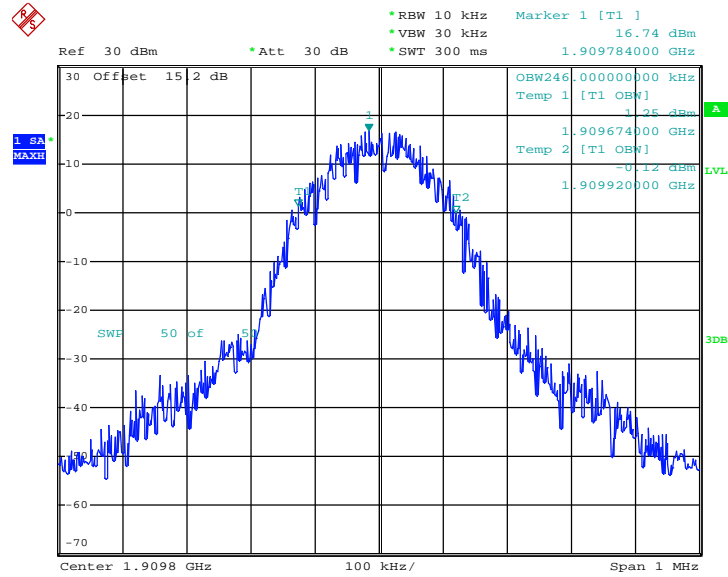

26dB Bandwidth Plot on Channel 810 (1909.8 MHz)

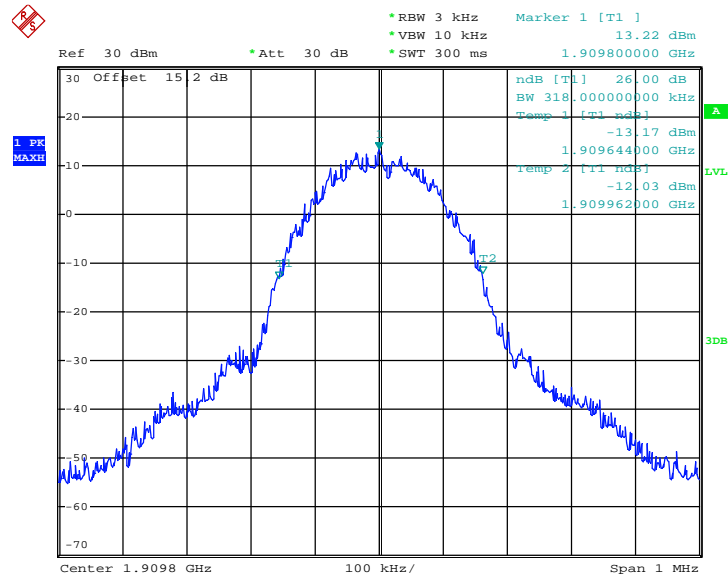



Band :	WCDMA Band V	Test Mode :	RMC 12.2Kbps Link (QPSK)
--------	--------------	-------------	--------------------------

99% Occupied Bandwidth Plot on Channel 4132 (826.4 MHz)

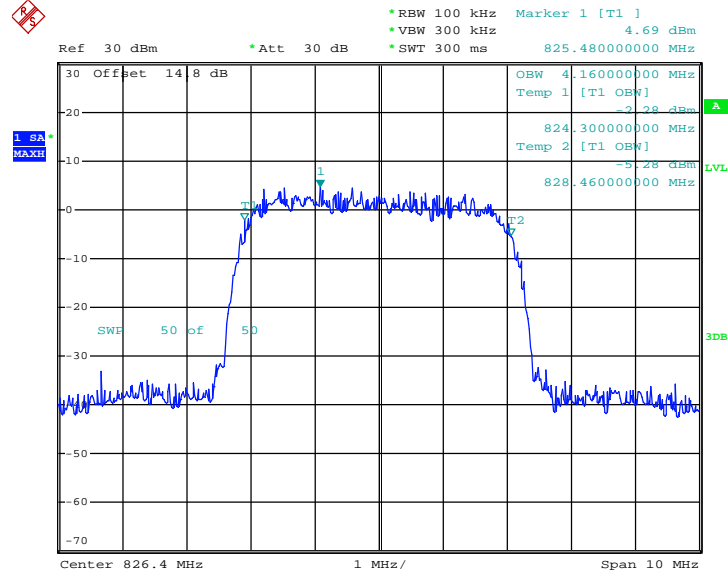

26dB Bandwidth Plot on Channel 4132 (826.4 MHz)

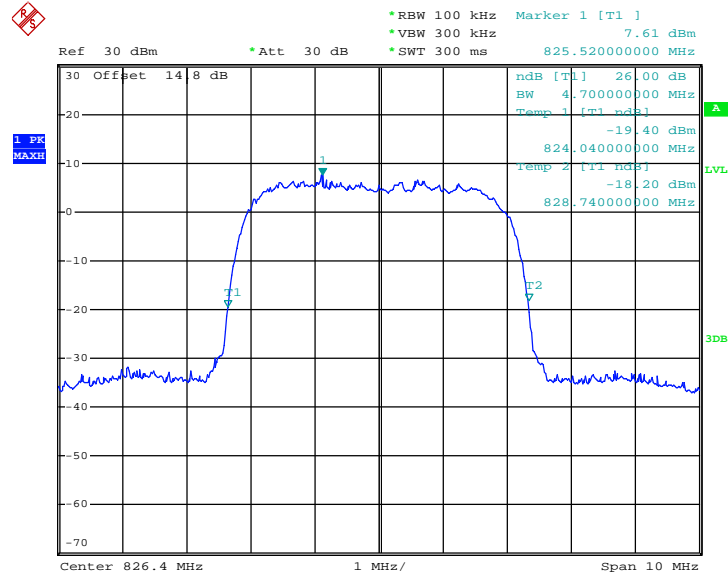



99% Occupied Bandwidth Plot on Channel 4182 (836.4 MHz)

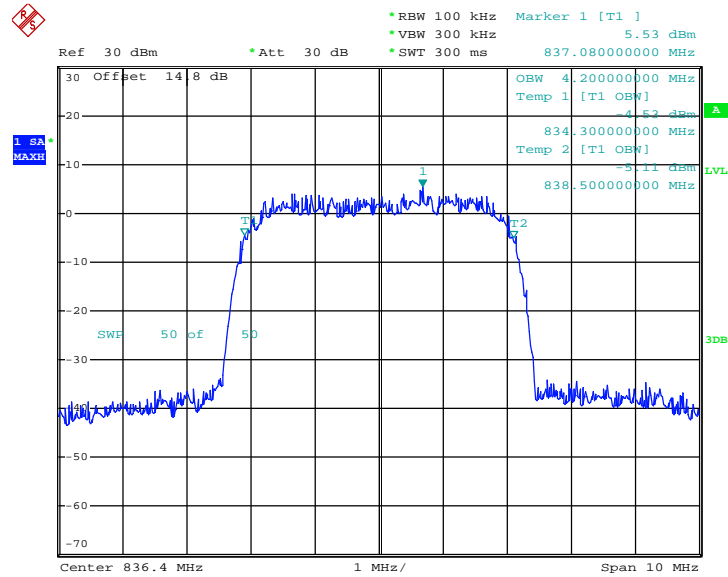

26dB Bandwidth Plot on Channel 4182 (836.4 MHz)

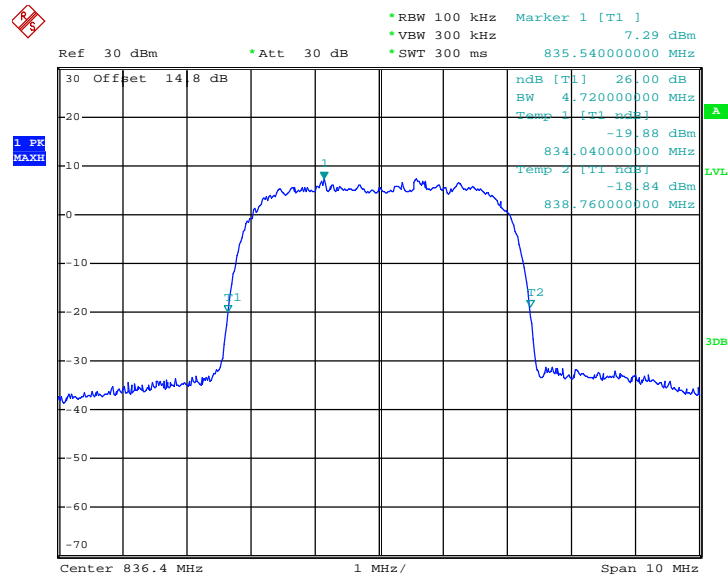



99% Occupied Bandwidth Plot on Channel 4233 (846.6 MHz)

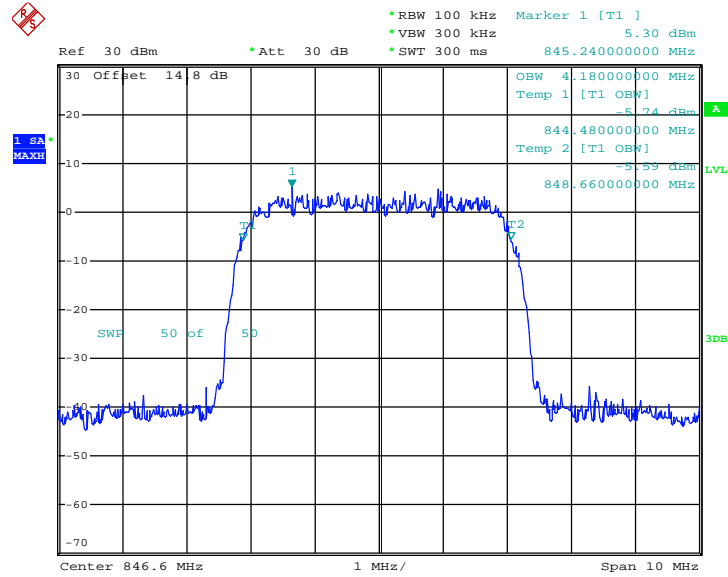

26dB Bandwidth Plot on Channel 4233 (846.6 MHz)

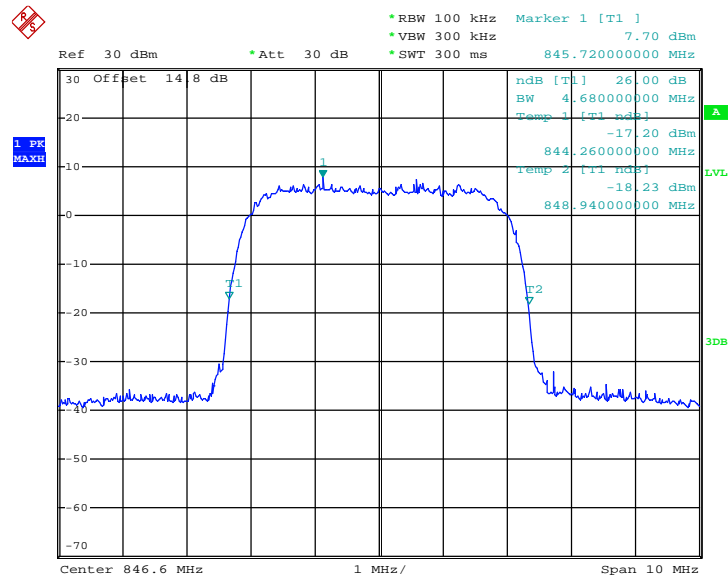



Band :	WCDMA Band II	Test Mode :	RMC 12.2Kbps Link (QPSK)
--------	---------------	-------------	--------------------------

### 99% Occupied Bandwidth Plot on Channel 9262 (1852.4 MHz)

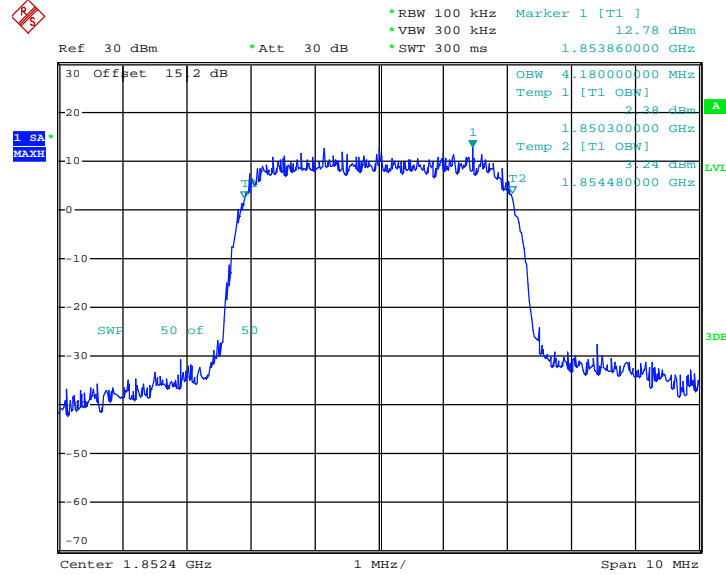

### 26dB Bandwidth Plot on Channel 9262 (1852.4 MHz)

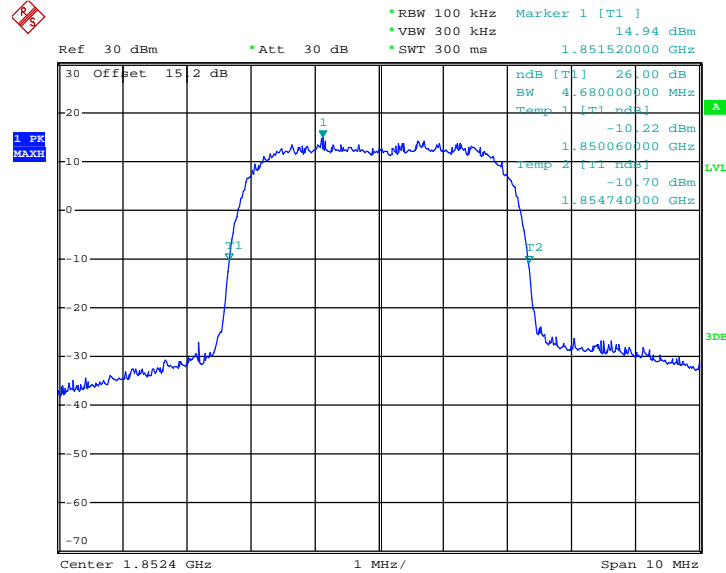



99% Occupied Bandwidth Plot on Channel 9400 (1880.0 MHz)

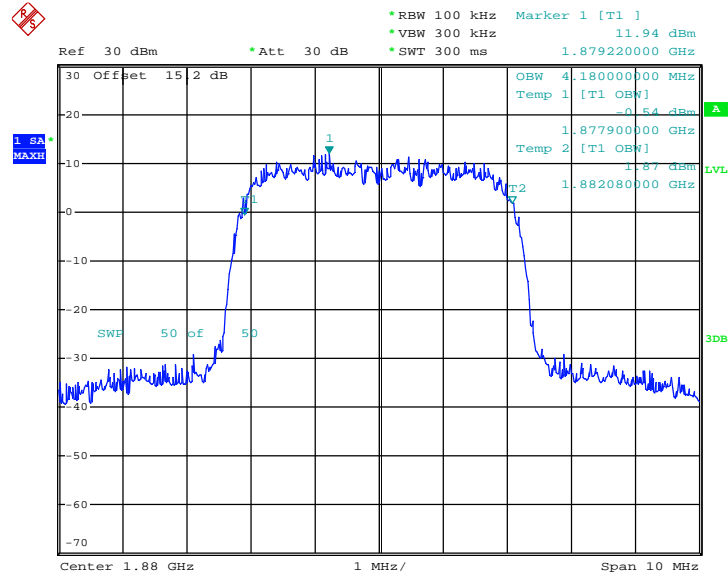

26dB Bandwidth Plot on Channel 9400 (1880.0 MHz)

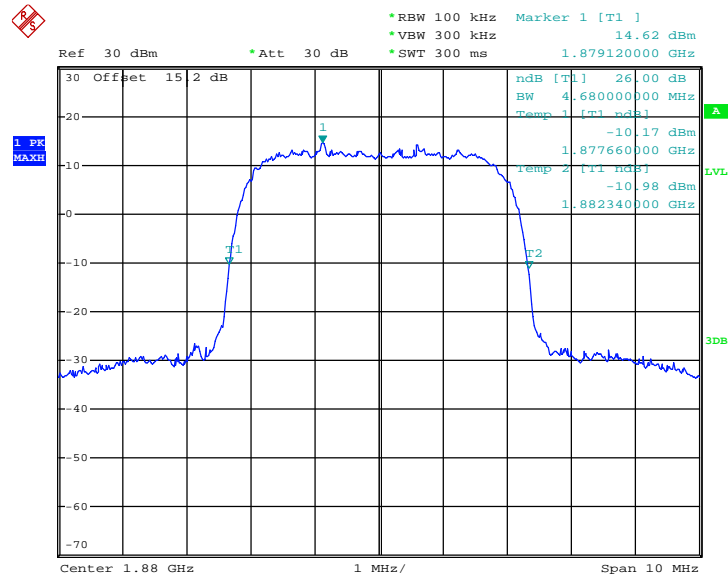



99% Occupied Bandwidth Plot on Channel 9538 (1907.6 MHz)

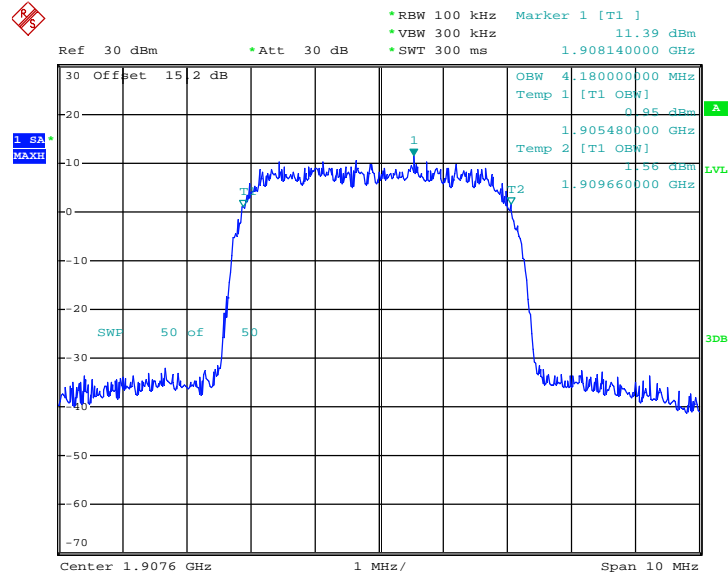

26dB Bandwidth Plot on Channel 9538 (1907.6 MHz)

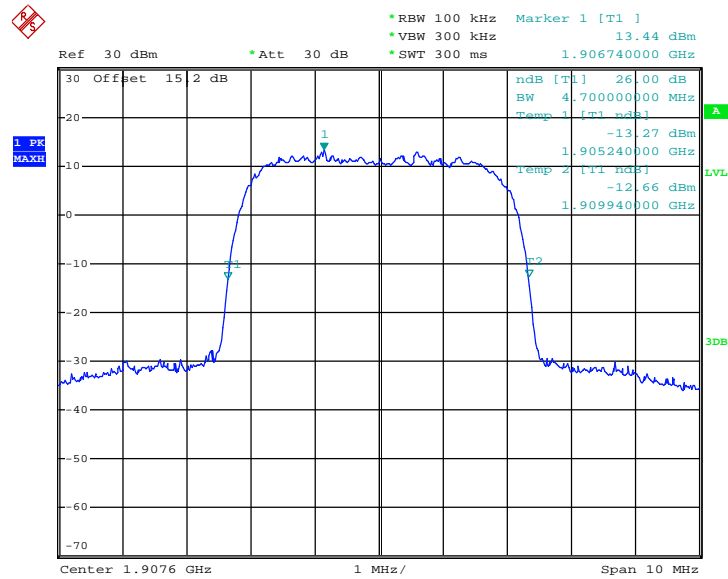



## 3.5 Band Edge Measurement

### 3.5.1 Description of Band Edge Measurement

The power of any emission outside of the authorized operating frequency ranges must be lower than the transmitter power (P) by a factor of at least  $43 + 10 \log (P)$  dB.

### 3.5.2 Measuring Instruments

The measuring equipment is listed in the section 4 of this test report.

### 3.5.3 Test Procedures

1. The EUT was connected to Spectrum Analyzer and Base Station via power divider.
2. The RF output of EUT was connected to the spectrum analyzer by RF cable and attenuator. The path loss was compensated to the results for each measurement.
3. The band edges of low and high channels for the highest RF powers were measured. Setting RBW as roughly  $BW/100$ .
4. The RF fundamental frequency should be excluded against the limit line in the operating frequency band.
5. The limit line is derived from  $43 + 10\log(P)$  dB below the transmitter power P(Watts)  
 $= P(W) - [43 + 10\log(P)]$  (dB)  
 $= [30 + 10\log(P)]$  (dBm) -  $[43 + 10\log(P)]$  (dB)  
 $= -13\text{dBm}$ .

### 3.5.4 Test Setup

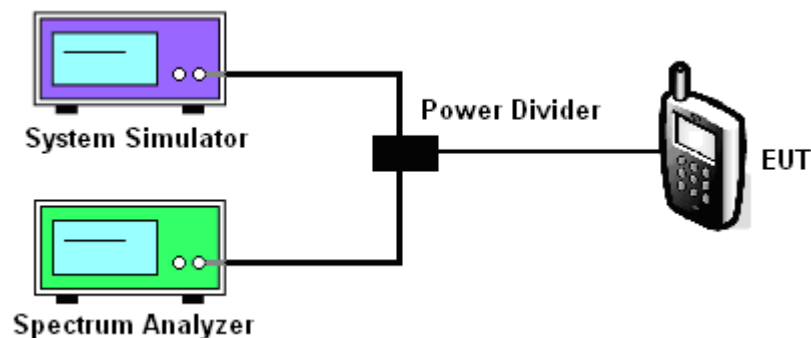

### 3.5.5 Test Result (Plots) of Conducted Band Edge

Band :	GSM850	Test Mode :	GSM Link (GMSK)
Correction Factor :	0.17dB	Maximum 26dB Bandwidth :	0.312MHz
Band Edge :	-17.53dBm	Measurement Value :	-17.70dBm

Lower Band Edge Plot on Channel 128 (824.2 MHz)

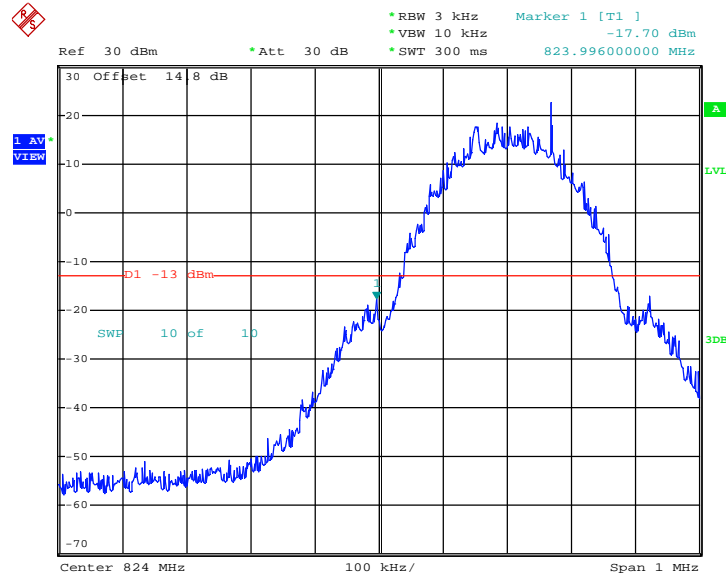

1. Correction Factor(dB)=  $10\log(1\% \text{ Emission BW/RBW})$
  2. Band Edge= Measurement Value + Correction Factor(dB)
- For example,  $-17.70\text{dBm} + 0.17\text{dB} = -17.53\text{dBm}$



Band :	GSM850	Test Mode :	GSM Link (GMSK)
Correction Factor :	0.17dB	Maximum 26dB Bandwidth :	0.312MHz
Band Edge :	-16.85dBm	Measurement Value :	-17.02dBm

Higher Band Edge Plot on Channel 251 (848.8 MHz)

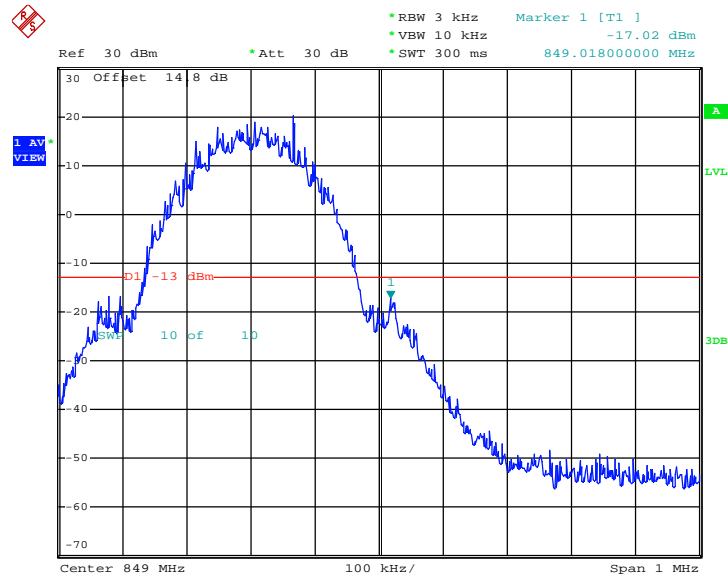

1. Correction Factor(dB)= 10log(1% Emission BW/RBW)
2. Band Edge= Measurement Value + Correction Factor(dB)



Band :	GSM850	Test Mode :	EDGE class 8 Link (8PSK)
Correction Factor :	0.28dB	Maximum 26dB Bandwidth :	0.320MHz
Band Edge :	-21.49dBm	Measurement Value :	-21.77dBm

Lower Band Edge Plot on Channel 128 (824.2 MHz)

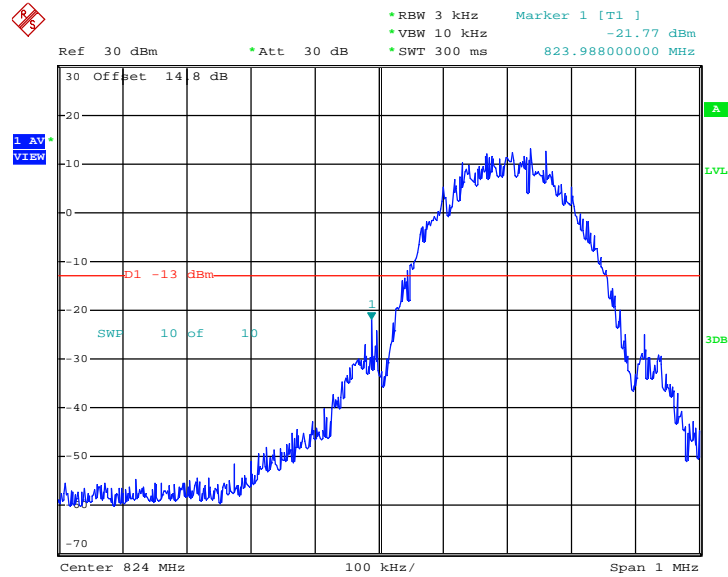

1. Correction Factor(dB)=  $10\log(1\% \text{ Emission BW/RBW})$
2. Band Edge= Measurement Value + Correction Factor(dB)



<b>Band :</b>	GSM850	<b>Test Mode :</b>	EDGE class 8 Link (8PSK)
<b>Correction Factor :</b>	0.28dB	<b>Maximum 26dB Bandwidth :</b>	0.320MHz
<b>Band Edge :</b>	-27.35dBm	<b>Measurement Value :</b>	-27.63dBm

**Higher Band Edge Plot on Channel 251 (848.8 MHz)**

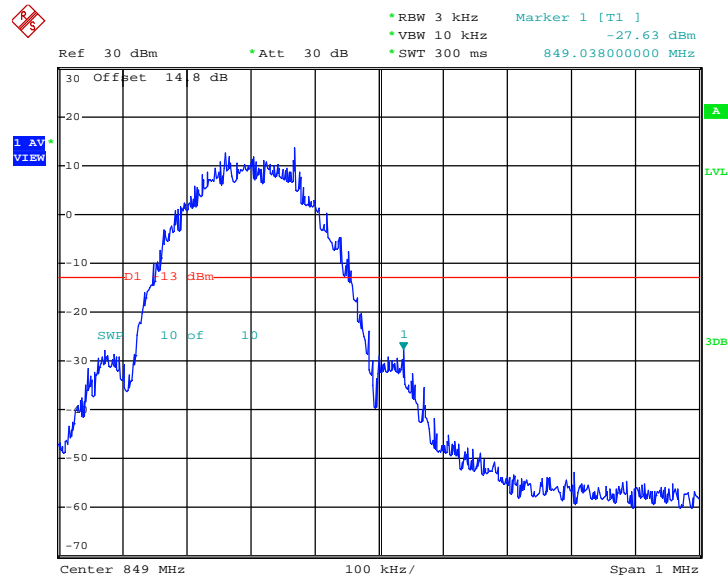

1. Correction Factor(dB)=  $10\log(1\% \text{ Emission BW/RBW})$
2. Band Edge= Measurement Value + Correction Factor(dB)



Band :	GSM1900	Test Mode :	GSM Link (GMSK)
Correction Factor :	0.17dB	Maximum 26dB Bandwidth :	0.312MHz
Band Edge :	-22.48dBm	Measurement Value :	-22.65dBm

Lower Band Edge Plot on Channel 512 (1850.2 MHz)

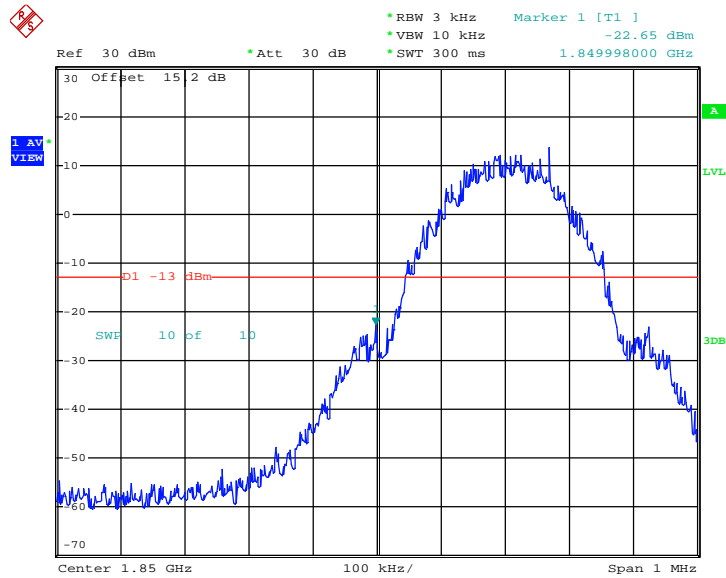

1. Correction Factor(dB)=  $10\log(1\% \text{ Emission BW/RBW})$
2. Band Edge= Measurement Value + Correction Factor(dB)

Band :	GSM1900	Test Mode :	GSM Link (GMSK)
Correction Factor :	0.17dB	Maximum 26dB Bandwidth :	0.312MHz
Band Edge :	-24.86dBm	Measurement Value :	-25.03dBm

Higher Band Edge Plot on Channel 810 (1909.8 MHz)

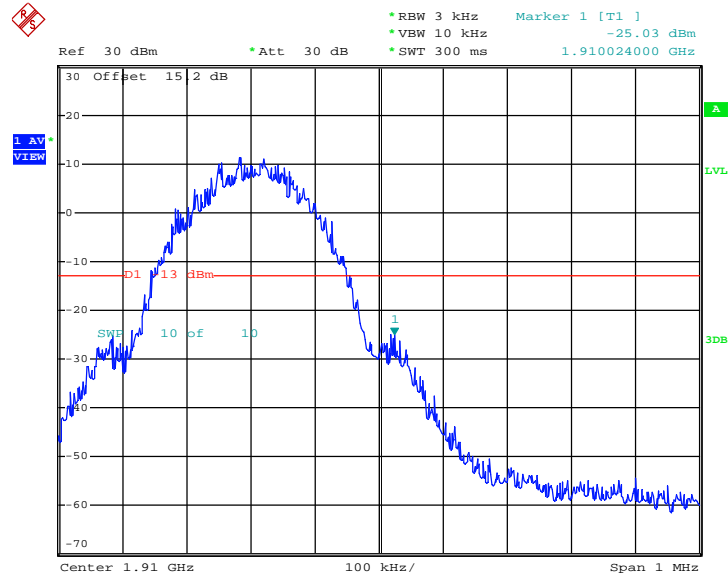

1. Correction Factor(dB)= 10log(1% Emission BW/RBW)
2. Band Edge= Measurement Value + Correction Factor(dB)



Band :	GSM1900	Test Mode :	EDGE class 8 Link (8PSK)
Correction Factor :	0.25dB	Maximum 26dB Bandwidth :	0.318MHz
Band Edge :	-30.89dBm	Measurement Value :	-31.14dBm

Lower Band Edge Plot on Channel 512 (1850.2 MHz)

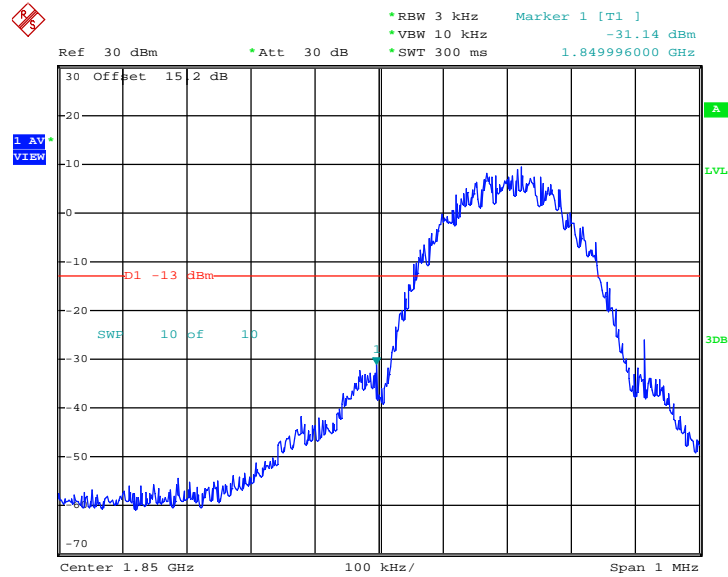

1. Correction Factor(dB)=  $10\log(1\% \text{ Emission BW/RBW})$
2. Band Edge= Measurement Value + Correction Factor(dB)





<b>Band :</b>	GSM1900	<b>Test Mode :</b>	EDGE class 8 Link (8PSK)
<b>Correction Factor :</b>	0.25dB	<b>Maximum 26dB Bandwidth :</b>	0.318MHz
<b>Band Edge :</b>	-29.41dBm	<b>Measurement Value :</b>	-29.66dBm

Higher Band Edge Plot on Channel 810 (1909.8 MHz)

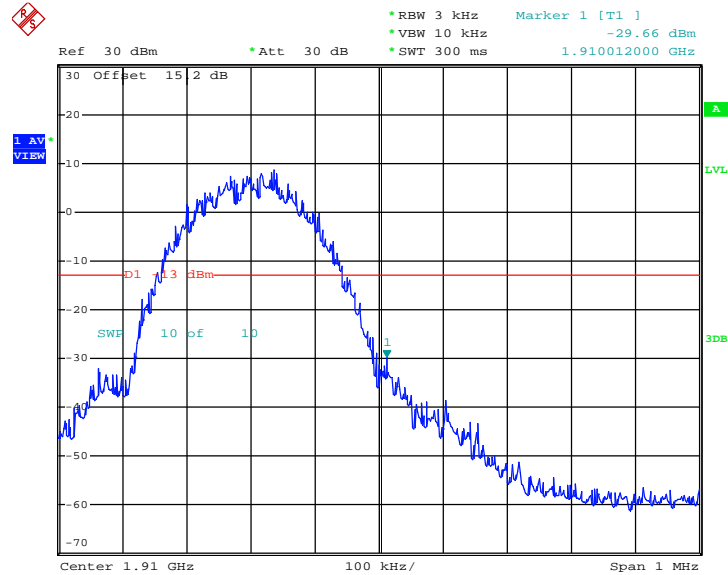

1. Correction Factor(dB)=  $10\log(1\% \text{ Emission BW/RBW})$
2. Band Edge= Measurement Value + Correction Factor(dB)



<b>Band :</b>	WCDMA Band V	<b>Test Mode :</b>	RMC 12.2Kbps Link (QPSK)
<b>Correction Factor :</b>	-3.26dB	<b>Maximum 26dB Bandwidth :</b>	4.720MHz
<b>Band Edge :</b>	-38.52dBm	<b>Measurement Value :</b>	-35.26dBm

Lower Band Edge Plot on Channel 4132 (826.4 MHz)

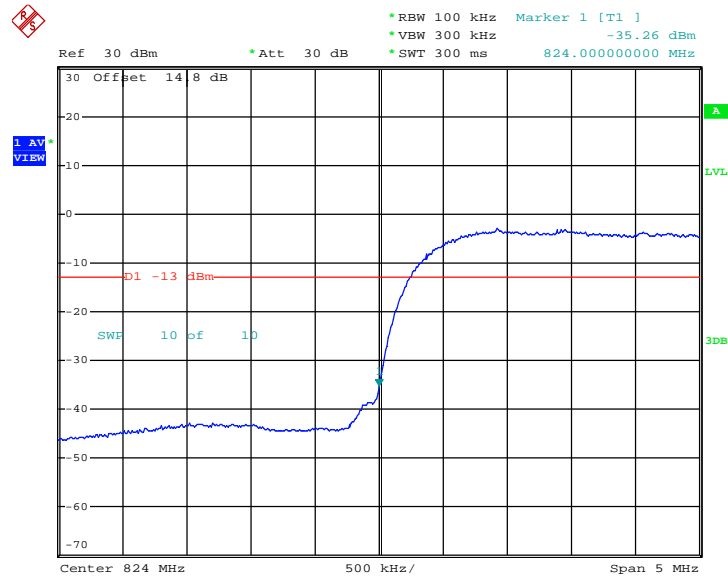

1. Correction Factor(dB)=  $10\log(1\% \text{ Emission BW/RBW})$
2. Band Edge= Measurement Value + Correction Factor(dB)



Band :	WCDMA Band V	Test Mode :	RMC 12.2Kbps Link (QPSK)
Correction Factor :	-3.26dB	Maximum 26dB Bandwidth :	4.720MHz
Band Edge :	-39.20dBm	Measurement Value :	-35.94dBm

Higher Band Edge Plot on Channel 4233 (846.6 MHz)

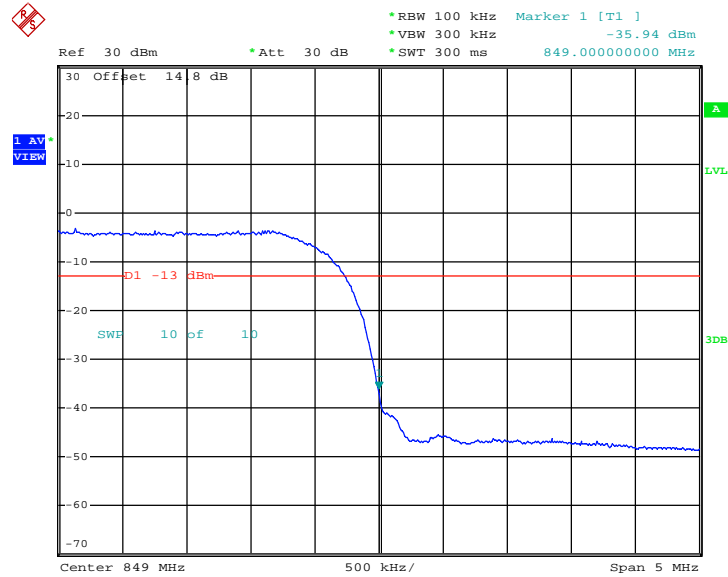

1. Correction Factor(dB)=  $10\log(1\% \text{ Emission BW/RBW})$
2. Band Edge= Measurement Value + Correction Factor(dB)



Band :	WCDMA Band II	Test Mode :	RMC 12.2Kbps Link (QPSK)
Correction Factor :	-3.28dB	Maximum 26dB Bandwidth :	4.700MHz
Band Edge :	-31.36dBm	Measurement Value :	-28.08dBm

Lower Band Edge Plot on Channel 9262 (1852.4 MHz)

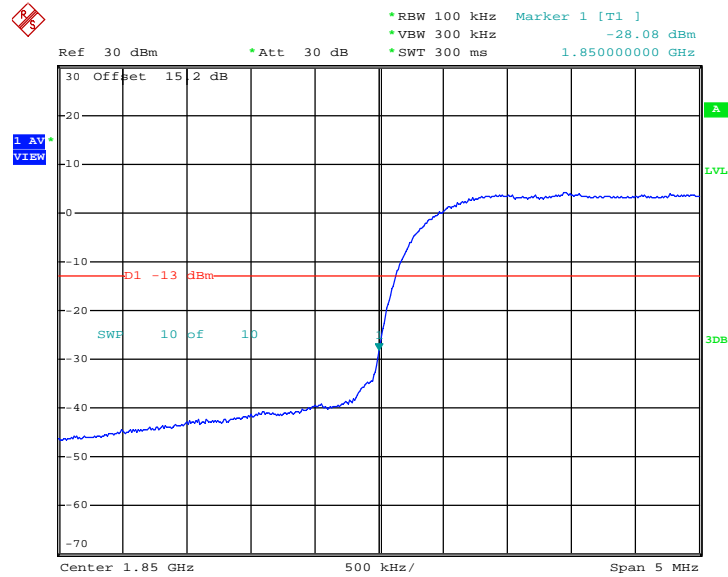

1. Correction Factor(dB)=  $10\log(1\% \text{ Emission BW/RBW})$
2. Band Edge= Measurement Value + Correction Factor(dB)



Band :	WCDMA Band II	Test Mode :	RMC 12.2Kbps Link (QPSK)
Correction Factor :	-3.28dB	Maximum 26dB Bandwidth :	4.700MHz
Band Edge :	-33.71dBm	Measurement Value :	-30.43dBm

Higher Band Edge Plot on Channel 9538 (1907.6 MHz)

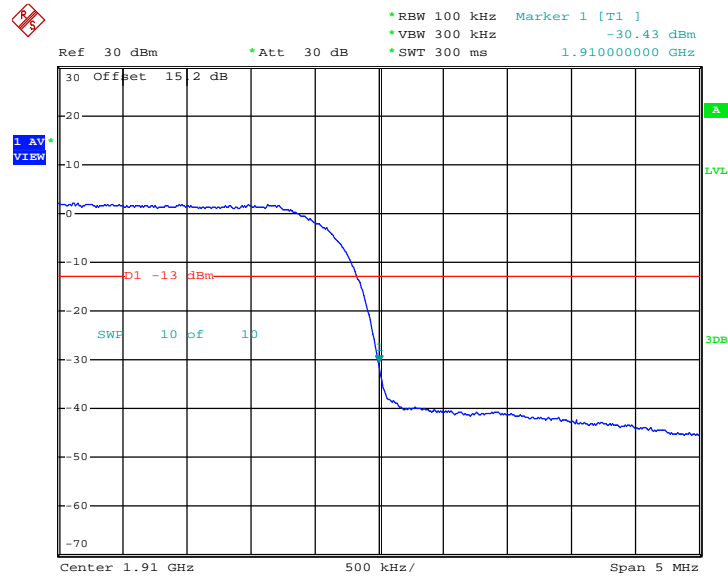

1. Correction Factor(dB)=  $10\log(1\% \text{ Emission BW/RBW})$
2. Band Edge= Measurement Value + Correction Factor(dB)

### 3.6 Conducted Spurious Emission Measurement

#### 3.6.1 Description of Conducted Spurious Emission Measurement

The power of any emission outside of the authorized operating frequency ranges must be lower than the transmitter power (P) by a factor of at least  $43 + 10 \log (P)$  dB.

It is measured by means of a calibrated spectrum analyzer and scanned from 30 MHz up to a frequency including its 10<sup>th</sup> harmonic.

#### 3.6.2 Measuring Instruments

The measuring equipment is listed in the section 4 of this test report.

#### 3.6.3 Test Procedures

1. The EUT was connected to spectrum analyzer and base station via power divider.
2. The RF output of EUT was connected to the spectrum analyzer by RF cable and attenuator. The path loss was compensated to the results for each measurement.
3. The middle channel for the highest RF power within the transmitting frequency was measured.
4. The conducted spurious emission for the whole frequency range was taken.
5. The RF fundamental frequency should be excluded against the limit line in the operating frequency band.
6. The limit line is derived from  $43 + 10\log(P)$  dB below the transmitter power P(Watts)
  - =  $P(W) - [43 + 10\log(P)]$  (dB)
  - =  $[30 + 10\log(P)]$  (dBm) -  $[43 + 10\log(P)]$  (dB)
  - = -13dBm

#### 3.6.4 Test Setup

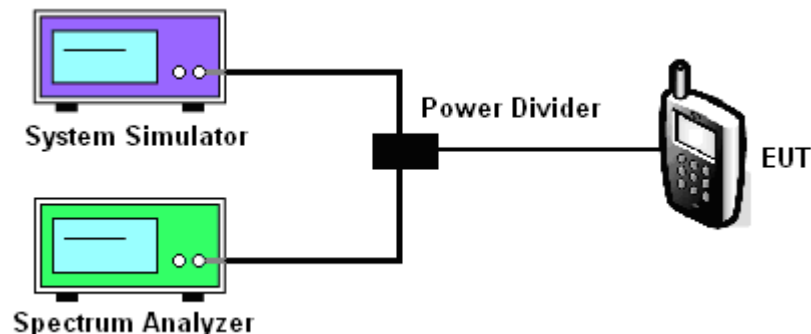

### 3.6.5 Test Result (Plots) of Conducted Spurious Emission

Band :	GSM850	Channel :	CH189
Test Mode :	GSM Link (GMSK)	Frequency :	836.4 MHz

Conducted Spurious Emission Plot between 30MHz ~ 1GHz

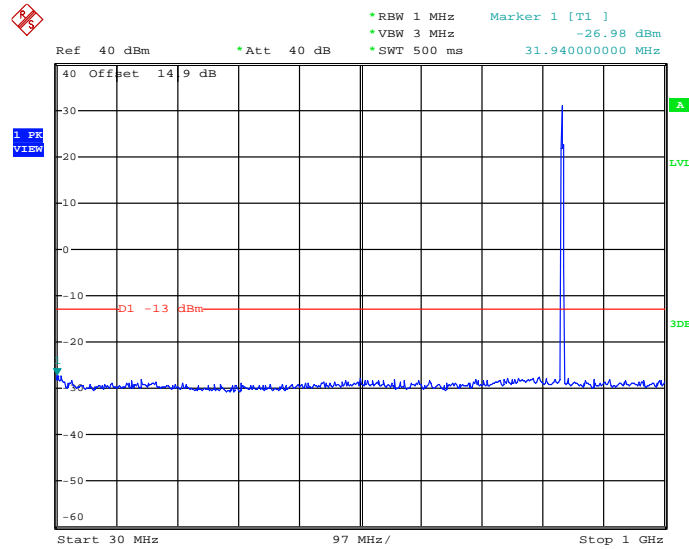

Conducted Spurious Emission Plot between 1GHz ~ 3GHz

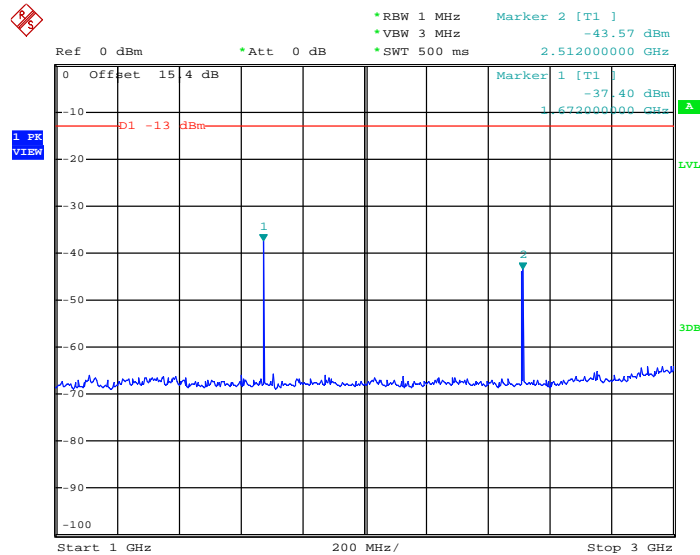



### Conducted Spurious Emission Plot between 3GHz ~ 7GHz

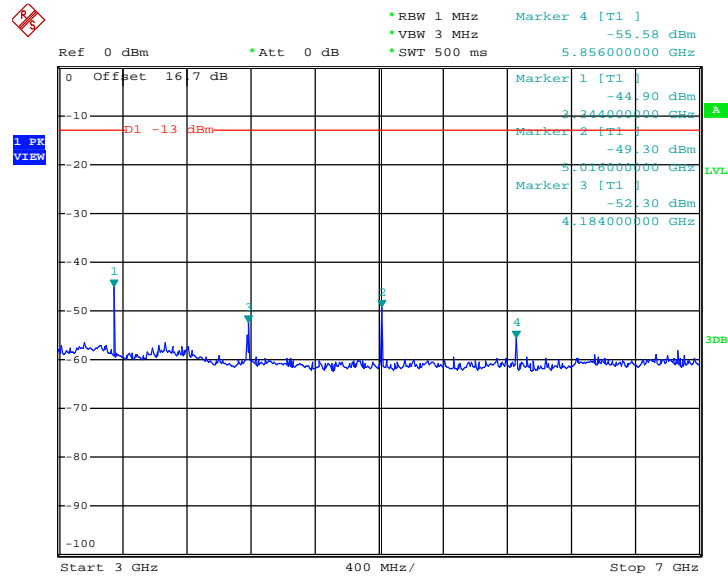

### Conducted Spurious Emission Plot between 7GHz ~ 9GHz

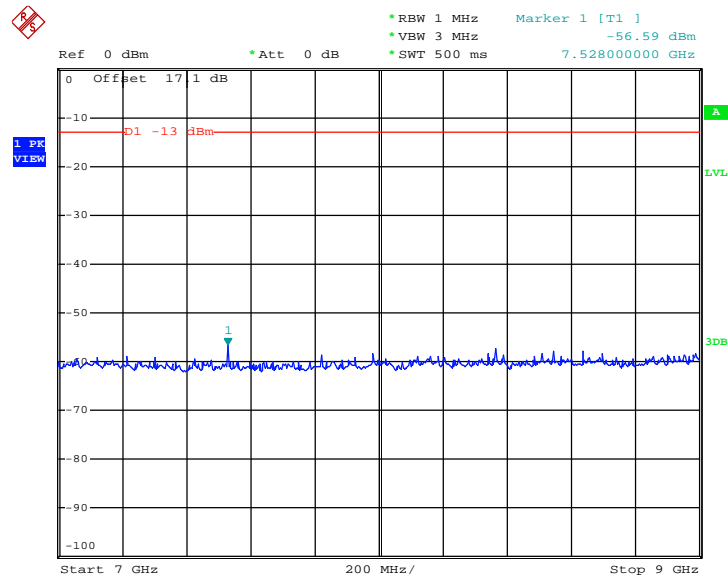





Band :	GSM850	Channel :	CH189
Test Mode :	EDGE class 8 Link (8PSK)	Frequency :	836.4 MHz

Conducted Spurious Emission Plot between 30MHz ~ 1GHz

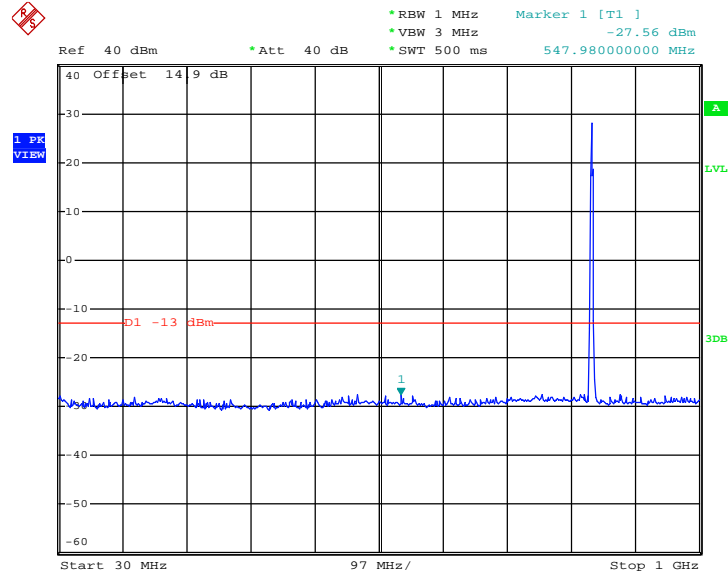

Conducted Spurious Emission Plot between 1GHz ~ 3GHz

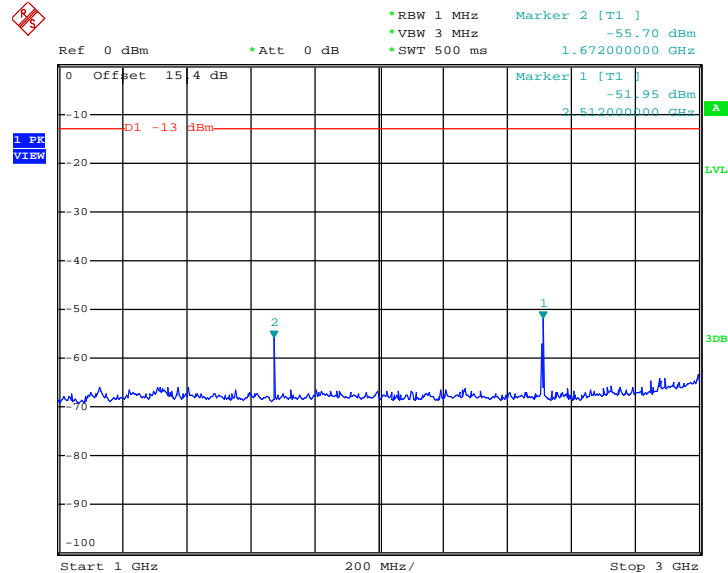



### Conducted Spurious Emission Plot between 3GHz ~ 7GHz

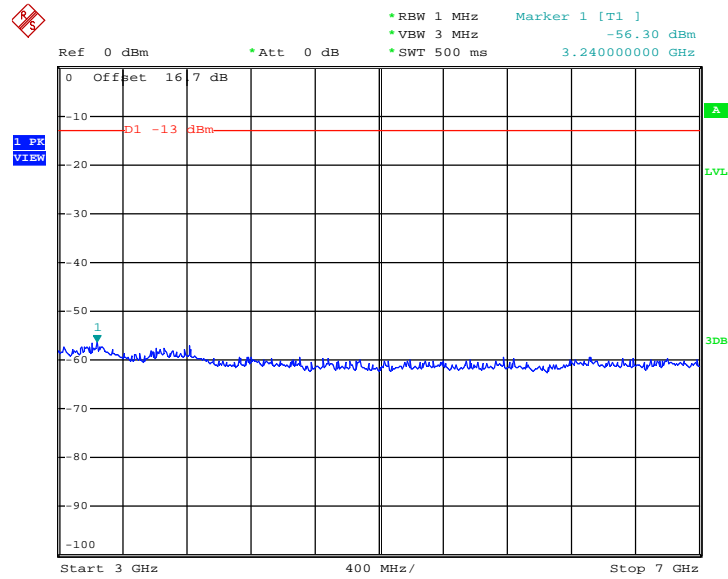

### Conducted Spurious Emission Plot between 7GHz ~ 9GHz

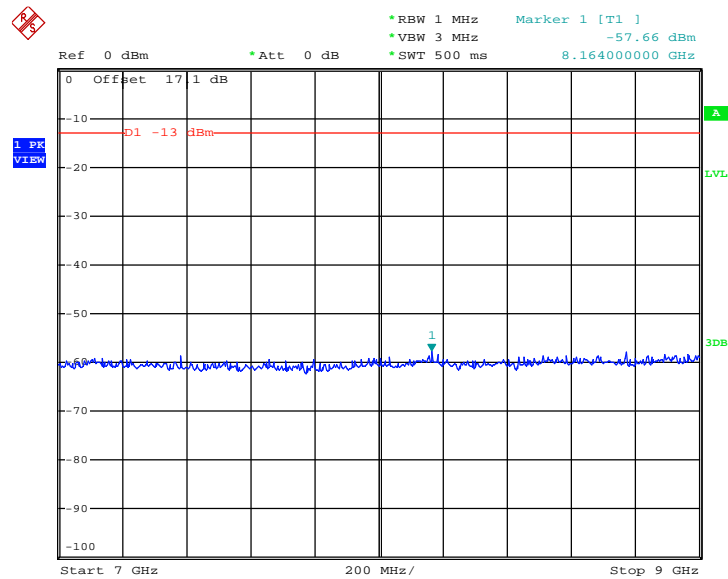



Band :	GSM1900	Channel :	CH661
Test Mode :	GSM Link (GMSK)	Frequency :	1880.0 MHz

Conducted Spurious Emission Plot between 30MHz ~ 1GHz

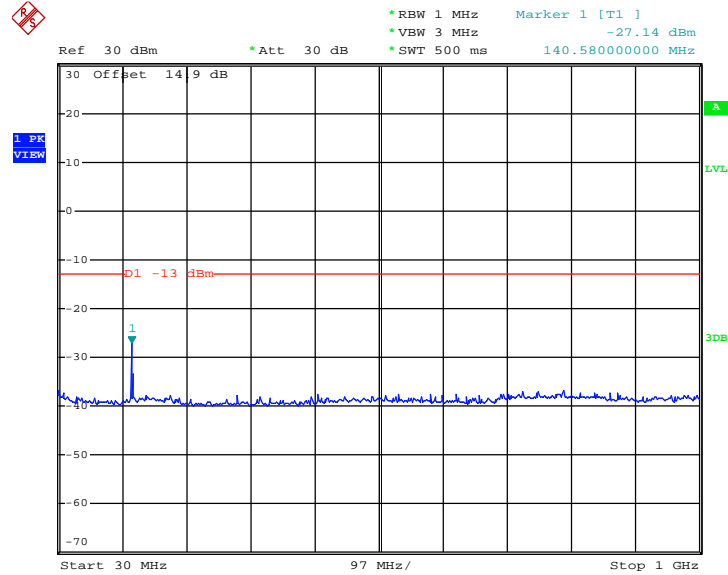

Conducted Spurious Emission Plot between 1GHz ~ 3GHz

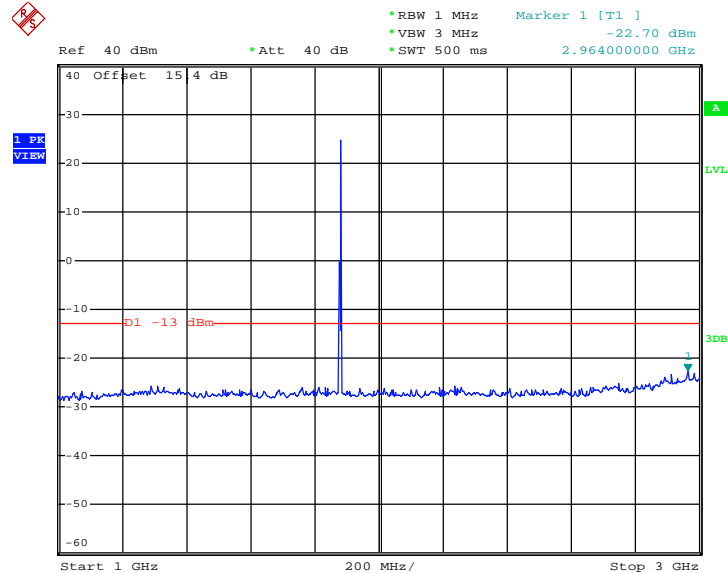



### Conducted Spurious Emission Plot between 3GHz ~ 7GHz

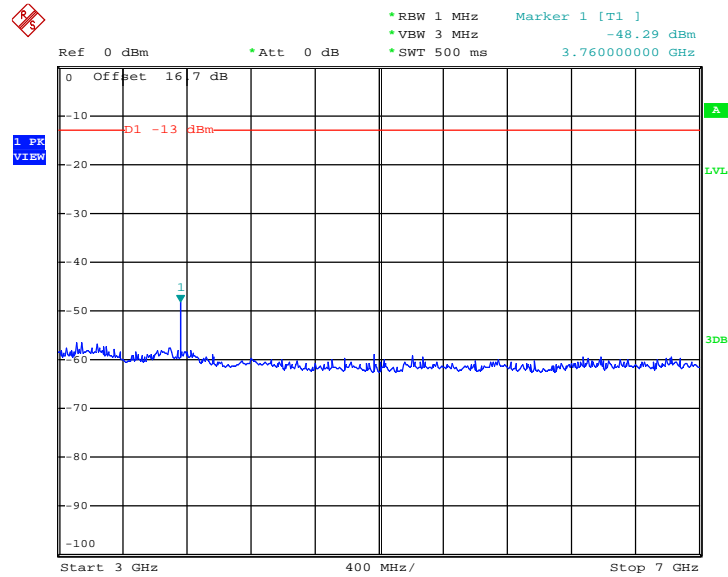

### Conducted Emission Plot between 7GHz ~ 13.6GHz

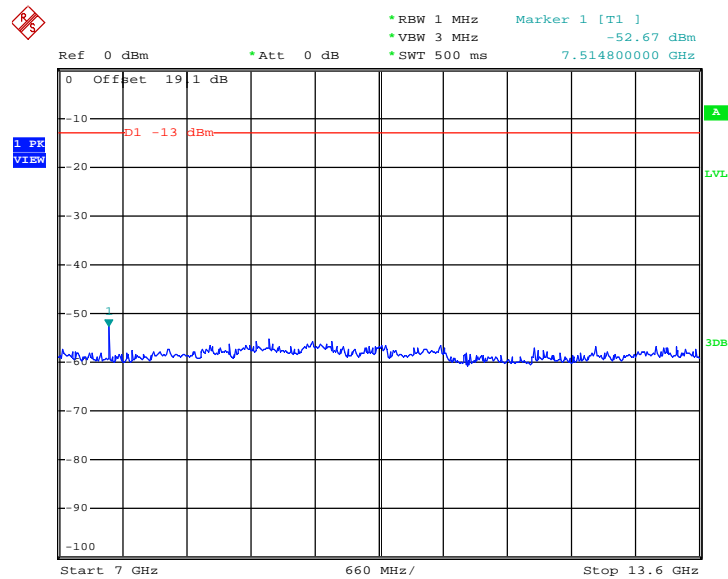



Conducted Spurious Emission Plot between 13.6GHz ~ 19.1GHz

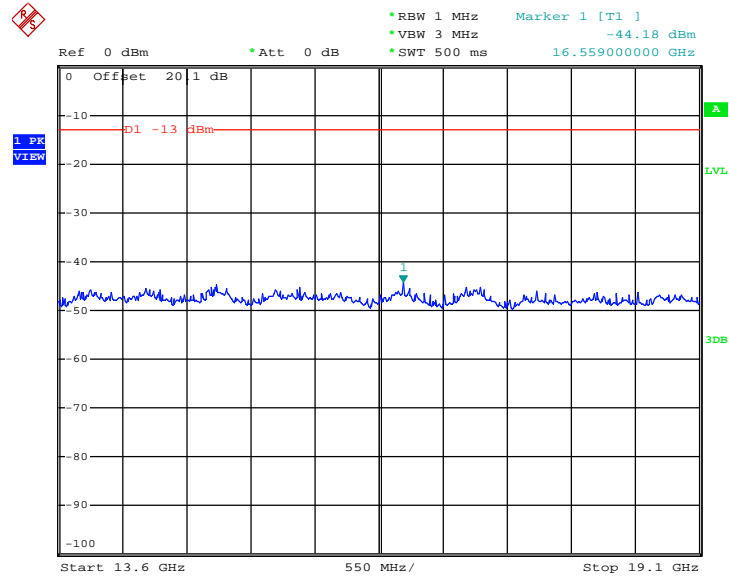



Band :	GSM1900	Channel :	CH661
Test Mode :	EDGE class 8 Link (8PSK)	Frequency :	1880.0 MHz

Conducted Spurious Emission Plot between 30MHz ~ 1GHz

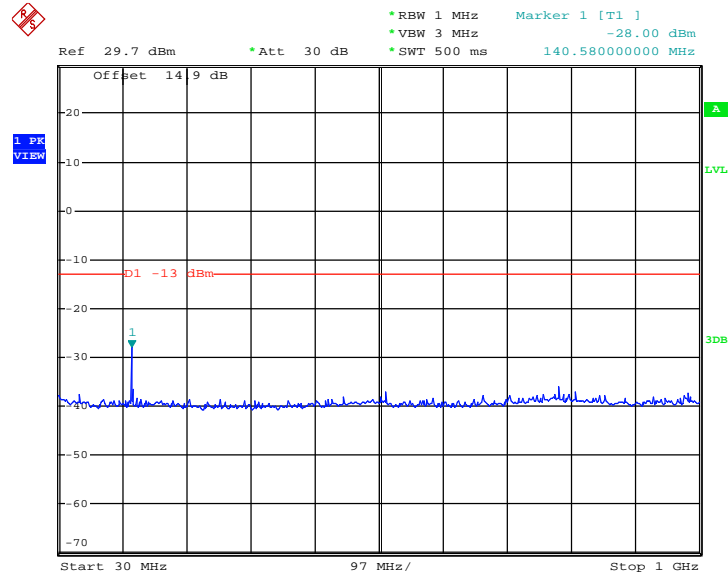

Conducted Spurious Emission Plot between 1GHz ~ 3GHz

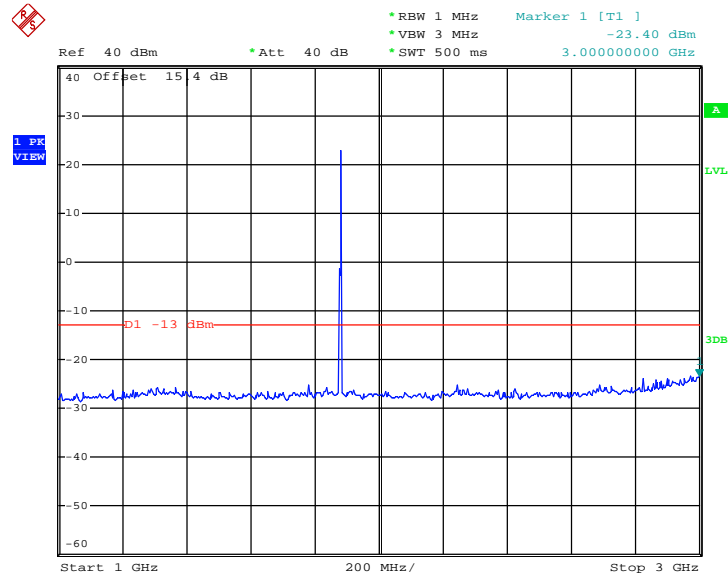



### Conducted Spurious Emission Plot between 3GHz ~ 7GHz

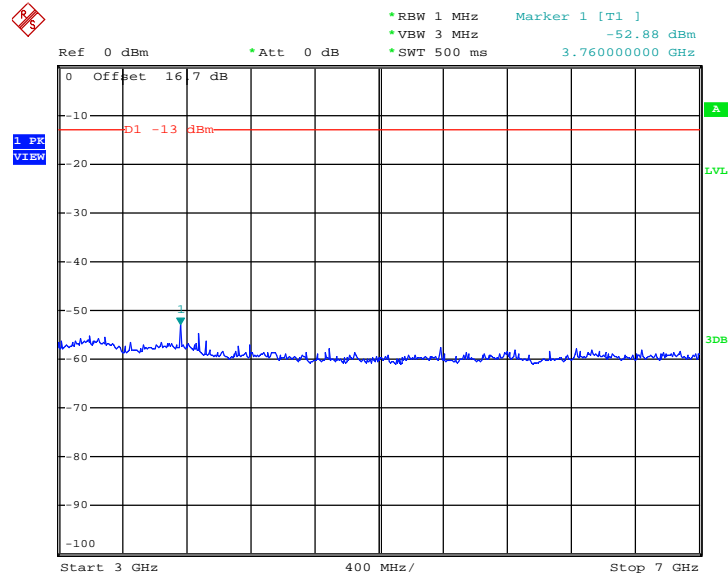

### Conducted Spurious Emission Plot between 7GHz ~ 13.6GHz

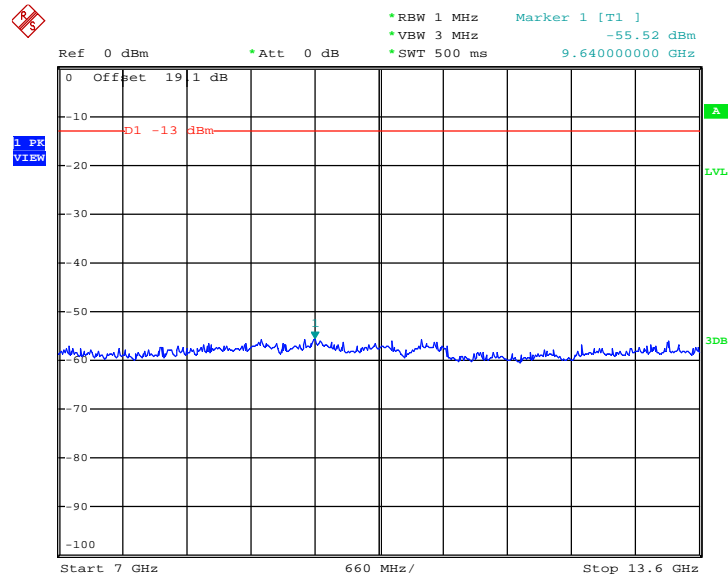



Conducted Spurious Emission Plot between 13.6GHz ~ 19.1GHz

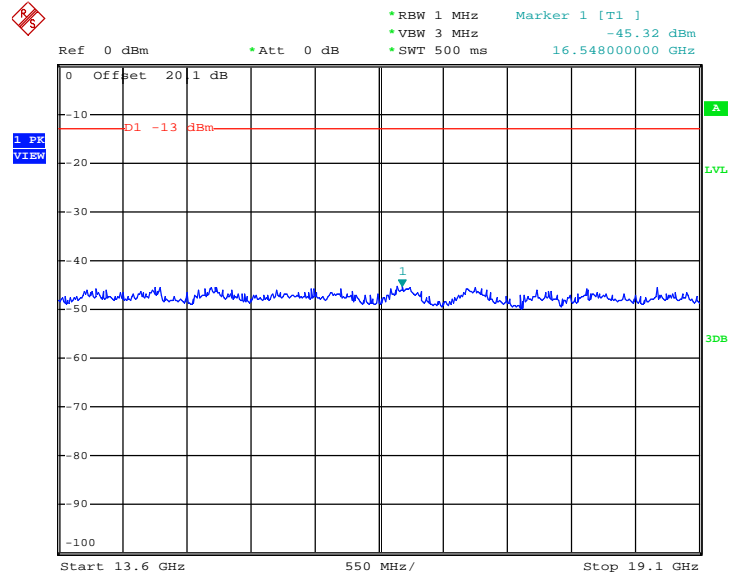





Band :	WCDMA Band V	Channel :	CH4182
Test Mode :	RMC 12.2Kbps Link (QPSK)	Frequency :	836.4 MHz

Conducted Spurious Emission Plot between 30MHz ~ 1GHz

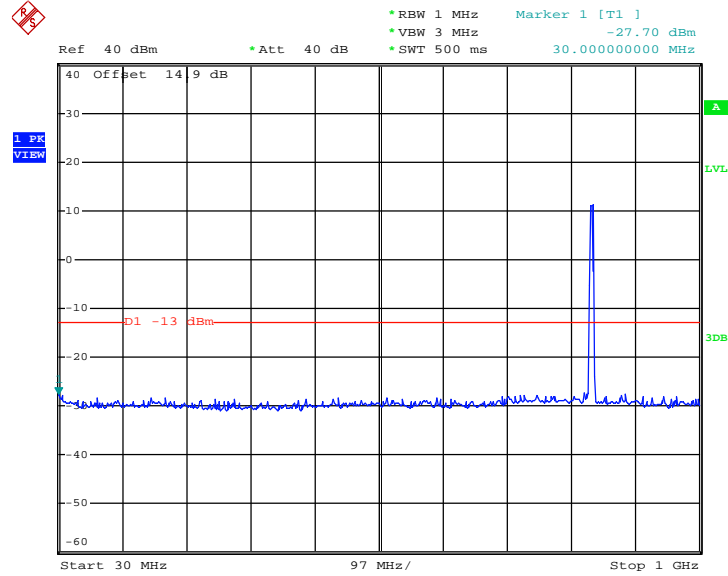

Conducted Spurious Emission Plot between 1GHz ~ 3GHz

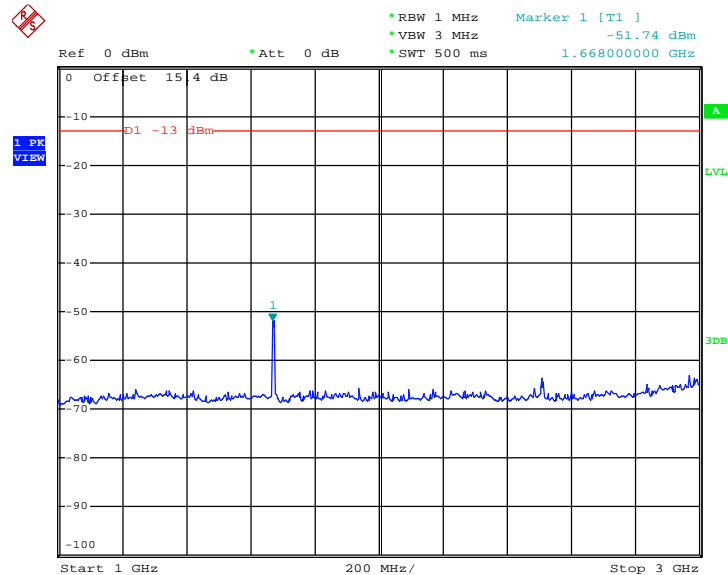



### Conducted Spurious Emission Plot between 3GHz ~ 7GHz

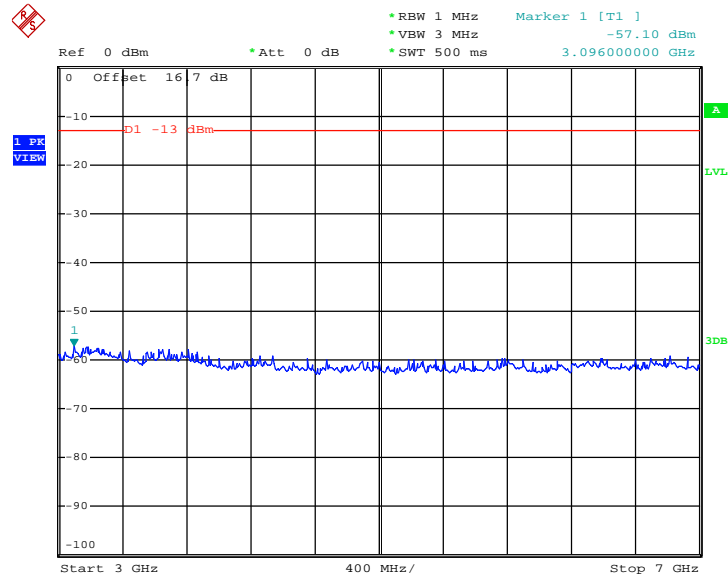

### Conducted Spurious Emission Plot between 7GHz ~ 9GHz

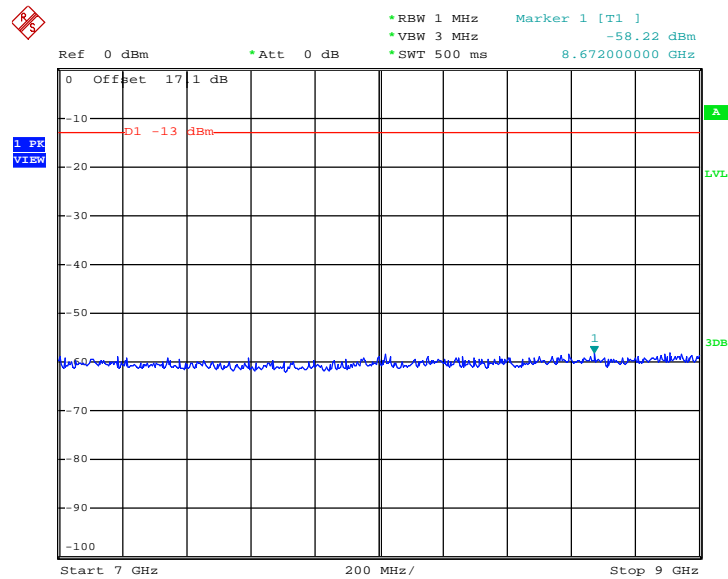



Band :	WCDMA Band II	Channel :	CH9400
Test Mode :	RMC 12.2Kbps Link (QPSK)	Frequency :	1880.0 MHz

Conducted Spurious Emission Plot between 30MHz ~ 1GHz

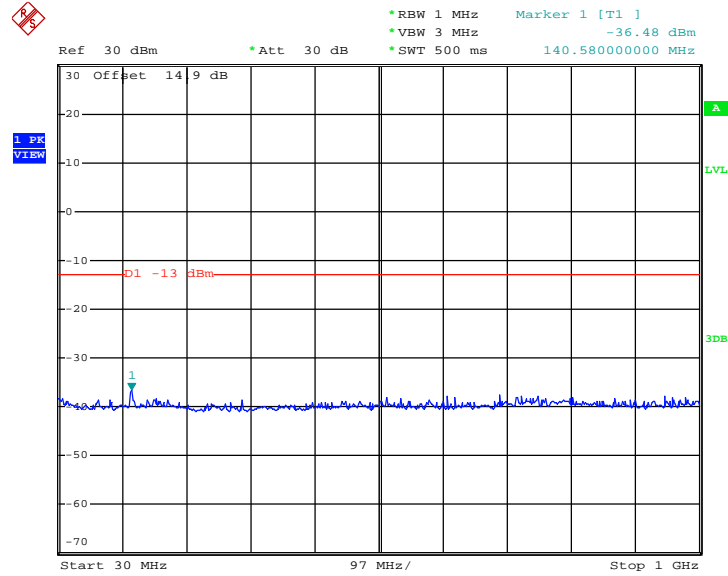

Conducted Spurious Emission Plot between 1GHz ~ 3GHz

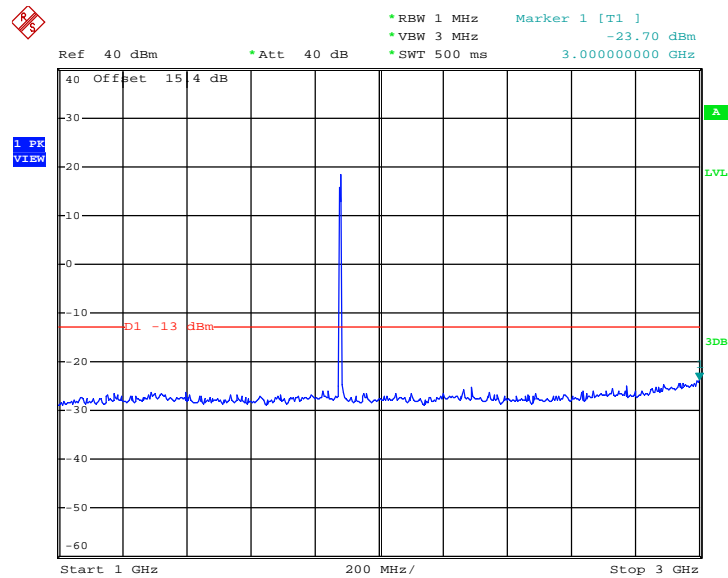



### Conducted Spurious Emission Plot between 3GHz ~ 7GHz

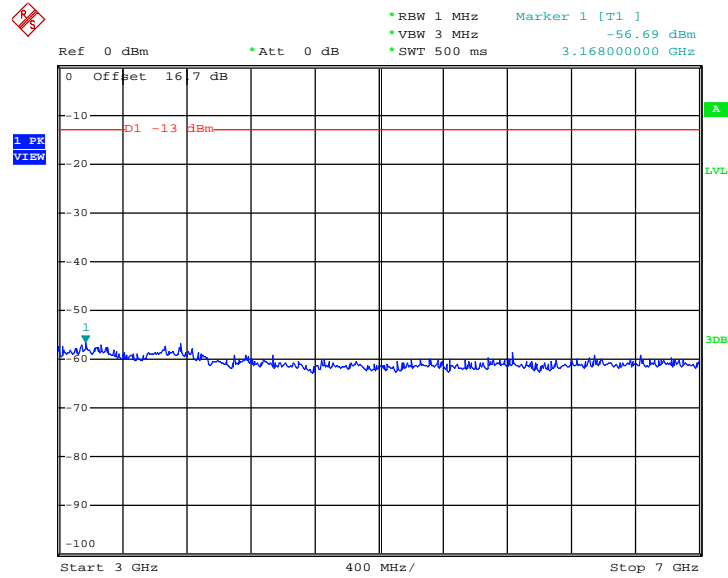

### Conducted Spurious Emission Plot between 7GHz ~ 13.6GHz

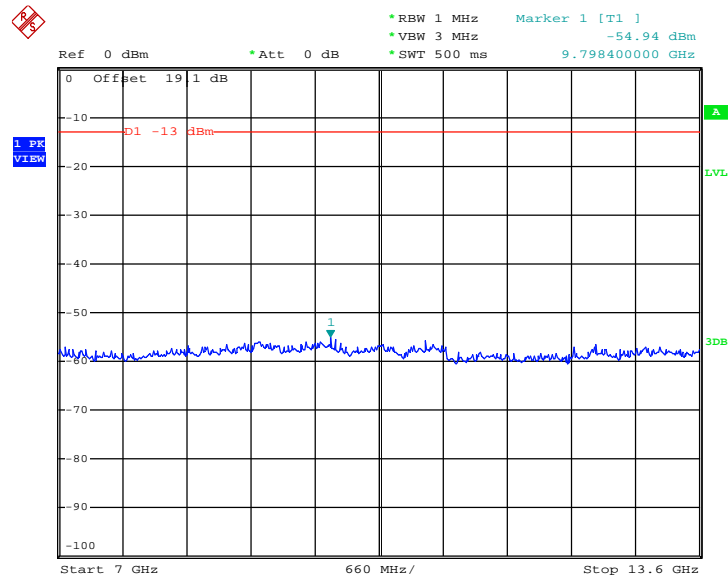



Conducted Spurious Emission Plot between 13.6GHz ~ 19.1GHz

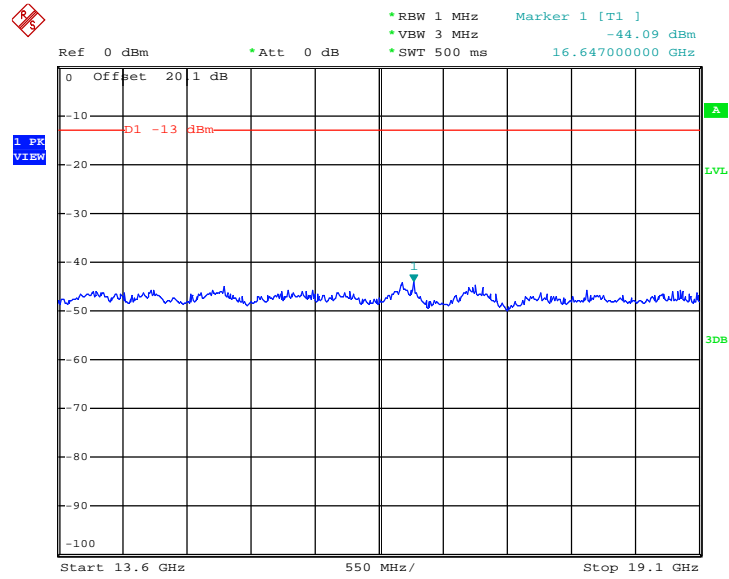

## 3.7 Field Strength of Spurious Radiation Measurement

### 3.7.1 Description of Field Strength of Spurious Radiated Measurement

The power of any emission outside of the authorized operating frequency ranges must be attenuated below the transmitter power (P) by a factor of at least  $43 + 10 \log(P)$  dB. The spectrum is scanned from 30 MHz up to a frequency including its 10th harmonic.

### 3.7.2 Measuring Instruments

The measuring equipment is listed in the section 4 of this test report.

### 3.7.3 Test Procedures

1. The EUT was placed on a rotatable wooden table with 0.8 meter above ground.
2. The EUT was set 3 meters from the receiving antenna, which was mounted on the antenna tower.
3. The table was rotated 360 degrees to determine the position of the highest spurious emission.
4. The height of the receiving antenna is varied between one meter and four meters to search the maximum spurious emission for both horizontal and vertical polarizations.
5. Make the measurement with the spectrum analyzer's RBW = 1MHz, VBW = 3MHz, taking the record of maximum spurious emission.
6. A horn antenna was substituted in place of the EUT and was driven by a signal generator.
7. Tune the output power of signal generator to the same emission level with EUT maximum spurious emission.
8. Taking the record of output power at antenna port.
9. Repeat step 7 to step 8 for another polarization.
10. The RF fundamental frequency should be excluded against the limit line in the operating frequency band.
11. The limit line is derived from  $43 + 10\log(P)$  dB below the transmitter power P(Watts)  
=  $P(W) - [43 + 10\log(P)]$  (dB)  
=  $[30 + 10\log(P)]$  (dBm) -  $[43 + 10\log(P)]$  (dB)  
= -13dBm.
12. EIRP (dBm) = S.G. Power – Tx Cable Loss + Tx Antenna Gain
13. ERP (dBm) = EIRP - 2.15

### 3.7.4 Test Setup

For radiated emissions from 30MHz to 1GHz

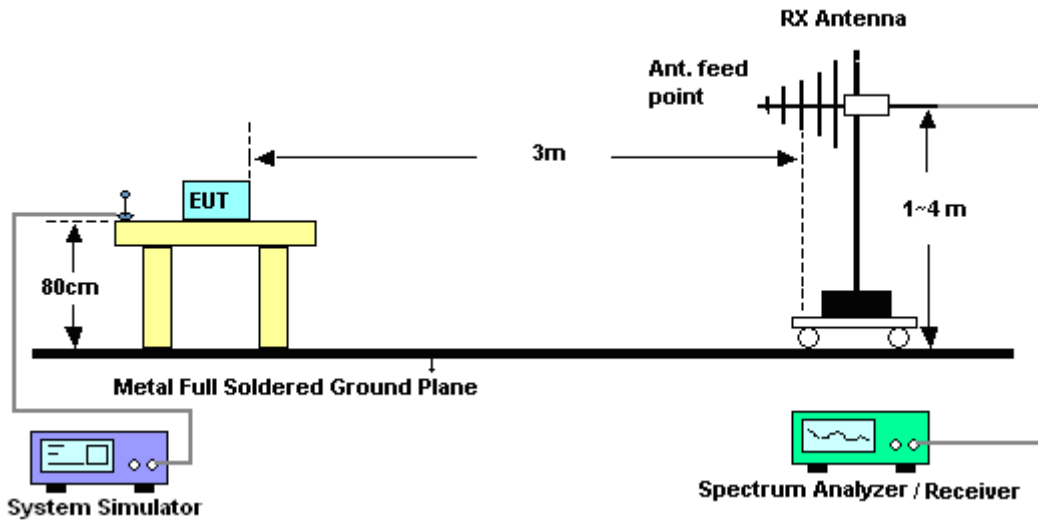

For radiated emissions above 1GHz

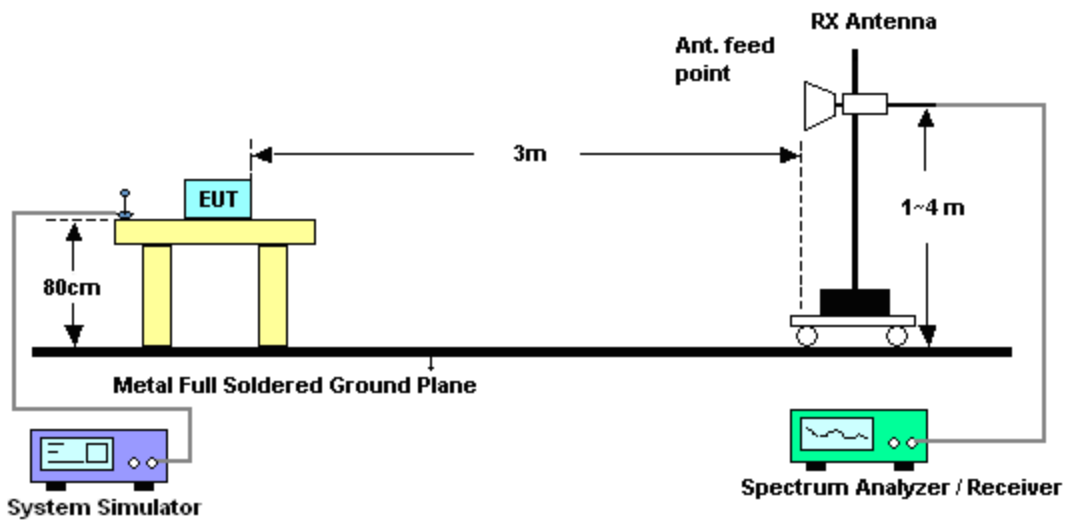



3.7.5 Test Result of Field Strength of Spurious Radiated

Band :	GSM850	Temperature :	22~23°C
Test Mode :	GSM Link (GMSK)	Relative Humidity :	42~43%
Test Engineer :	Stone Gu	Polarization :	Horizontal
Remark :	Spurious emissions within 30-1000MHz were found more than 20dB below limit line.		

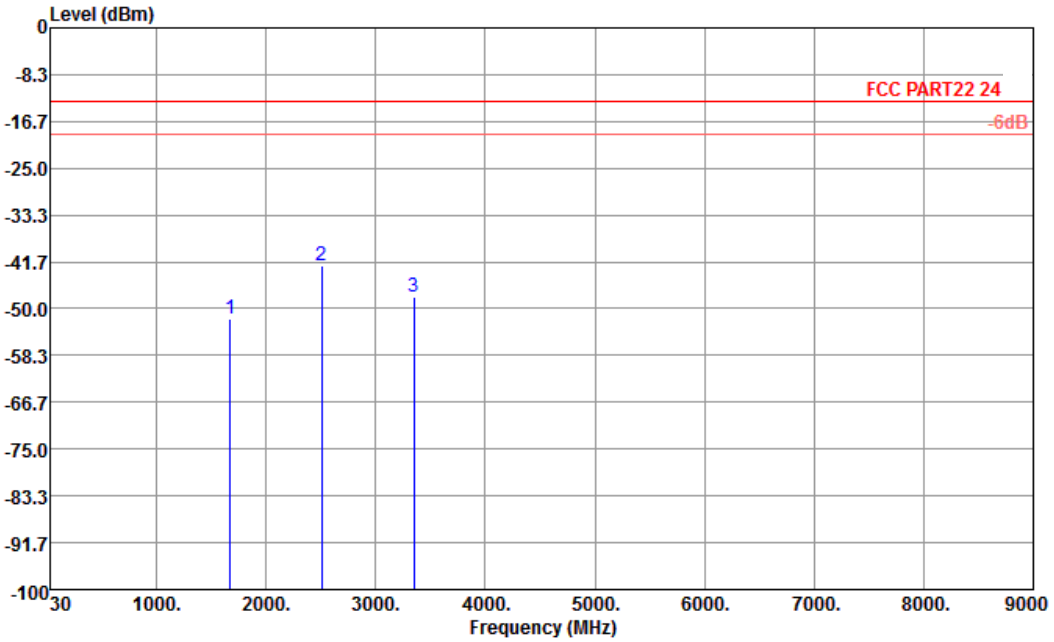

Site : 03CH01-KS  
 Condition : FCC PART22 24 HF\_EIRP\_FACTOR130726 HORIZONTAL  
 EUT : (FG) 3N1490

Frequency ( MHz )	ERP ( dBm )	Limit ( dBm )	Over Limit ( dB )	SPA Reading ( dBm )	S.G. Power ( dBm )	TX Cable loss ( dB )	TX Antenna Gain ( dBi )	Polarization ( H/V )	Result
1672	-51.79	-13	-38.79	-55.17	-52.44	0.57	3.37	H	Pass
2510	-42.44	-13	-29.44	-53.95	-44.67	0.78	5.16	H	Pass
3346	-47.81	-13	-34.81	-60.95	-51.45	0.87	6.66	H	Pass





<b>Band :</b>	GSM850	<b>Temperature :</b>	22~23°C
<b>Test Mode :</b>	GSM Link (GMSK)	<b>Relative Humidity :</b>	42~43%
<b>Test Engineer :</b>	Stone Gu	<b>Polarization :</b>	Vertical
<b>Remark :</b>	Spurious emissions within 30-1000MHz were found more than 20dB below limit line.		

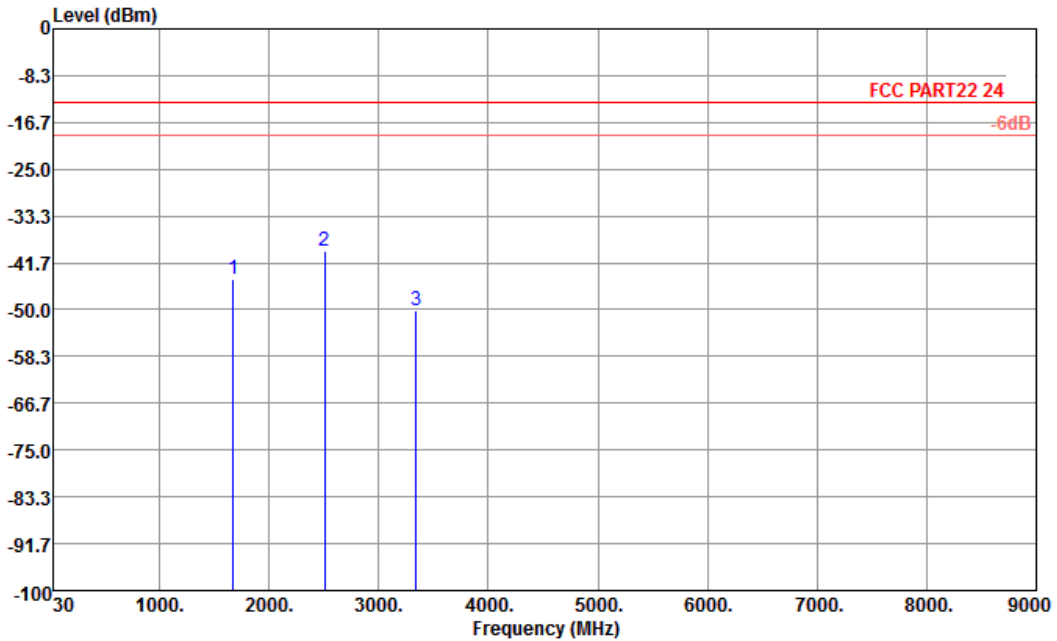

Site : 03CH01-KS  
 Condition : FCC PART22 24 HF\_EIRP\_FACTOR130726 VERTICAL  
 EUT : (FG) 3N1490

Frequency ( MHz )	ERP ( dBm )	Limit ( dBm )	Over Limit ( dB )	SPA Reading ( dBm )	S.G. Power ( dBm )	TX Cable loss ( dB )	TX Antenna Gain ( dBi )	Polarization ( H/V )	Result
1674	-44.58	-13	-31.58	-50.81	-45.23	0.57	3.37	V	Pass
2510	-39.60	-13	-26.60	-52.74	-41.83	0.78	5.16	V	Pass
3344	-50.23	-13	-37.23	-64.60	-53.87	0.87	6.66	V	Pass



<b>Band :</b>	GSM850	<b>Temperature :</b>	22~23°C
<b>Test Mode :</b>	EDGE class 8 Link (8PSK)	<b>Relative Humidity :</b>	42~43%
<b>Test Engineer :</b>	Stone Gu	<b>Polarization :</b>	Horizontal
<b>Remark :</b>	Spurious emissions within 30-1000MHz were found more than 20dB below limit line.		

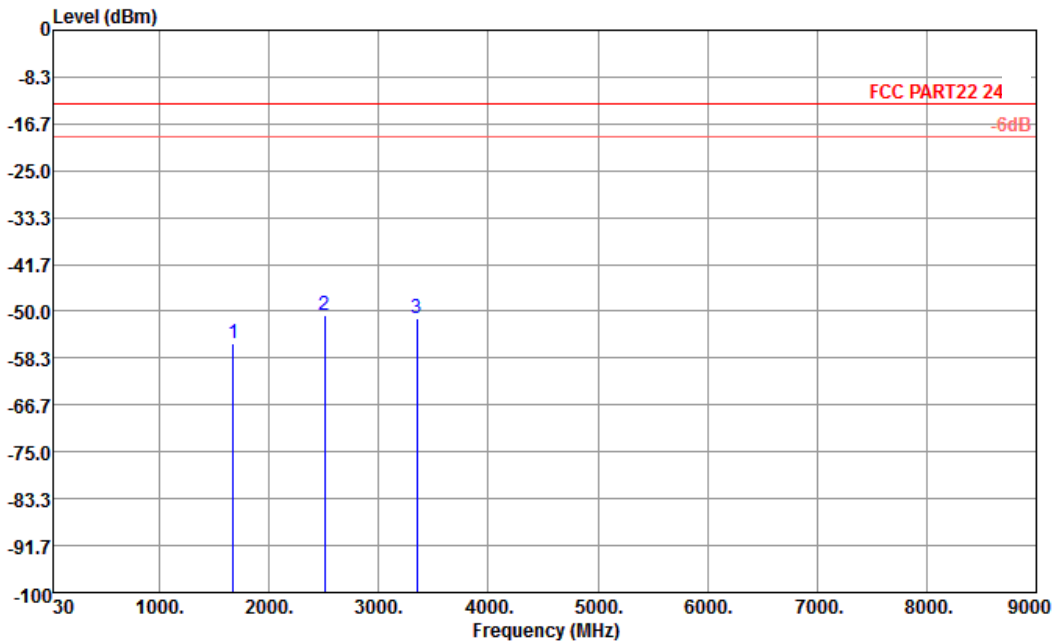

Site : 03CH01-KS  
 Condition : FCC PART22 24 HF\_EIRP\_FACTOR130726 HORIZONTAL  
 EUT : (FG) 3N1490

Frequency ( MHz )	ERP ( dBm )	Limit ( dBm )	Over Limit ( dB )	SPA Reading ( dBm )	S.G. Power ( dBm )	TX Cable loss ( dB )	TX Antenna Gain ( dBi )	Polarization ( H/V )	Result
1674	-55.80	-13	-42.80	-59.07	-56.45	0.57	3.37	H	Pass
2510	-50.76	-13	-37.76	-61.98	-52.99	0.78	5.16	H	Pass
3346	-51.15	-13	-38.15	-64.04	-54.79	0.87	6.66	H	Pass



<b>Band :</b>	GSM850	<b>Temperature :</b>	22~23°C
<b>Test Mode :</b>	EDGE class 8 Link (8PSK)	<b>Relative Humidity :</b>	42~43%
<b>Test Engineer :</b>	Stone Gu	<b>Polarization :</b>	Vertical
<b>Remark :</b>	Spurious emissions within 30-1000MHz were found more than 20dB below limit line.		

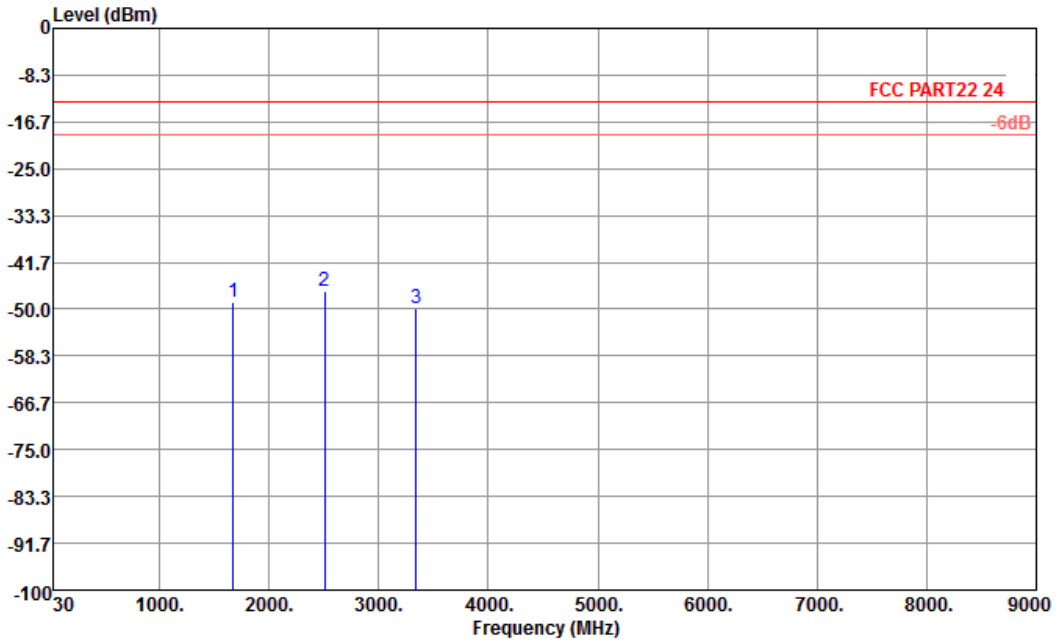

Site : 03CH01-KS  
 Condition : FCC PART22 24 HF\_EIRP\_FACTOR130726 VERTICAL  
 EUT : (FG) 3N1490

Frequency ( MHz )	ERP ( dBm )	Limit ( dBm )	Over Limit ( dB )	SPA Reading ( dBm )	S.G. Power ( dBm )	TX Cable loss ( dB )	TX Antenna Gain ( dBi )	Polarization ( H/V )	Result
1672	-48.69	-13	-35.69	-54.85	-49.34	0.57	3.37	V	Pass
2510	-46.74	-13	-33.74	-59.48	-48.97	0.78	5.16	V	Pass
3344	-49.77	-13	-36.77	-64.15	-53.41	0.87	6.66	V	Pass



<b>Band :</b>	GSM1900	<b>Temperature :</b>	22~23°C
<b>Test Mode :</b>	GSM Link (GMSK)	<b>Relative Humidity :</b>	42~43%
<b>Test Engineer :</b>	Stone Gu	<b>Polarization :</b>	Horizontal
<b>Remark :</b>	Spurious emissions within 30-1000MHz were found more than 20dB below limit line.		

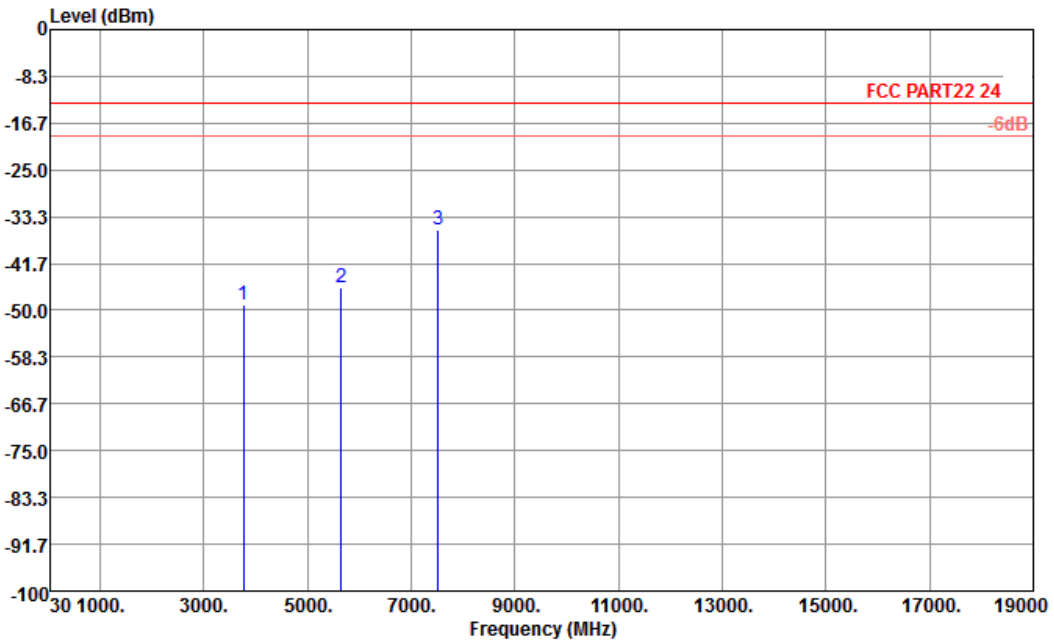

Site : 03CH01-KS  
 Condition : FCC PART22 24 HF\_EIRP\_FACTOR130726 HORIZONTAL  
 EUT : (FG) 3N1490

Frequency ( MHz )	EIRP ( dBm )	Limit ( dBm )	Over Limit ( dB )	SPA Reading ( dBm )	S.G. Power ( dBm )	TX Cable loss ( dB )	TX Antenna Gain ( dBi )	Polarization ( H/V )	Result
3760	-49.14	-13	-36.14	-64.36	-55.52	0.78	7.16	H	Pass
5640	-45.94	-13	-32.94	-64.46	-54.48	1.04	9.58	H	Pass
7520	-34.65	-13	-21.65	-54.01	-44.76	1.35	11.46	H	Pass



<b>Band :</b>	GSM1900	<b>Temperature :</b>	22~23°C
<b>Test Mode :</b>	GSM Link (GMSK)	<b>Relative Humidity :</b>	42~43%
<b>Test Engineer :</b>	Stone Gu	<b>Polarization :</b>	Vertical
<b>Remark :</b>	Spurious emissions within 30-1000MHz were found more than 20dB below limit line.		

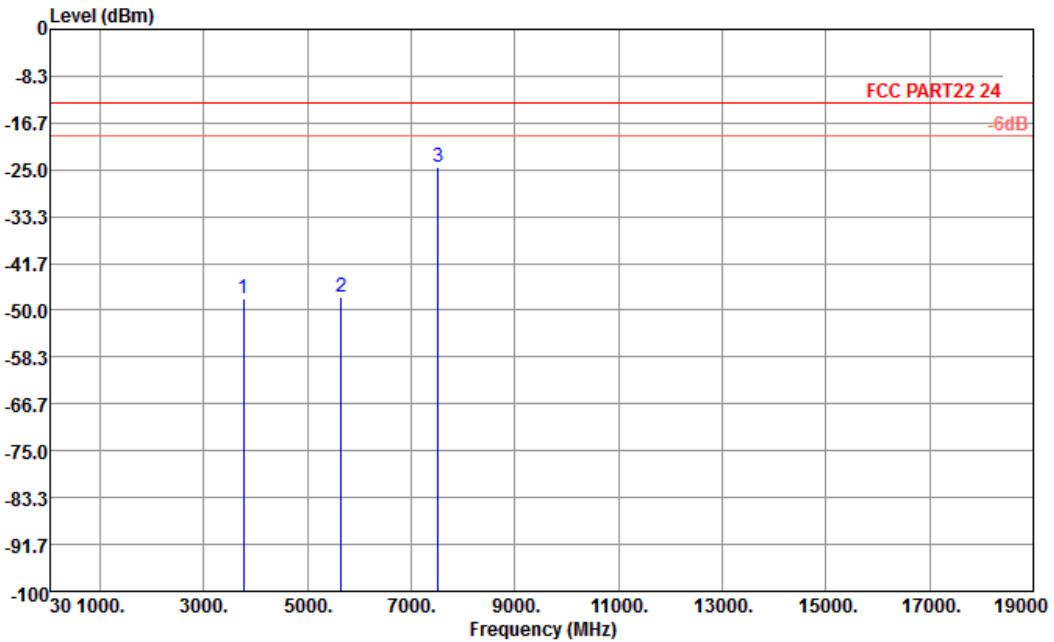

Site : 03CH01-KS  
 Condition : FCC PART22 24 HF\_EIRP\_FACTOR130726 VERTICAL  
 EUT : (FG) 3N1490

Frequency ( MHz )	EIRP ( dBm )	Limit ( dBm )	Over Limit ( dB )	SPA Reading ( dBm )	S.G. Power ( dBm )	TX Cable loss ( dB )	TX Antenna Gain ( dBi )	Polarization ( H/V )	Result
3760	-47.99	-13	-34.99	-63.59	-54.37	0.78	7.16	V	Pass
5640	-47.74	-13	-34.74	-65.14	-56.28	1.04	9.58	V	Pass
7520	-24.54	-13	-11.54	-43.22	-34.65	1.35	11.46	V	Pass



<b>Band :</b>	GSM1900	<b>Temperature :</b>	22~23°C
<b>Test Mode :</b>	EDGE class 8 Link (8PSK)	<b>Relative Humidity :</b>	42~43%
<b>Test Engineer :</b>	Stone Gu	<b>Polarization :</b>	Horizontal
<b>Remark :</b>	Spurious emissions within 30-1000MHz were found more than 20dB below limit line.		

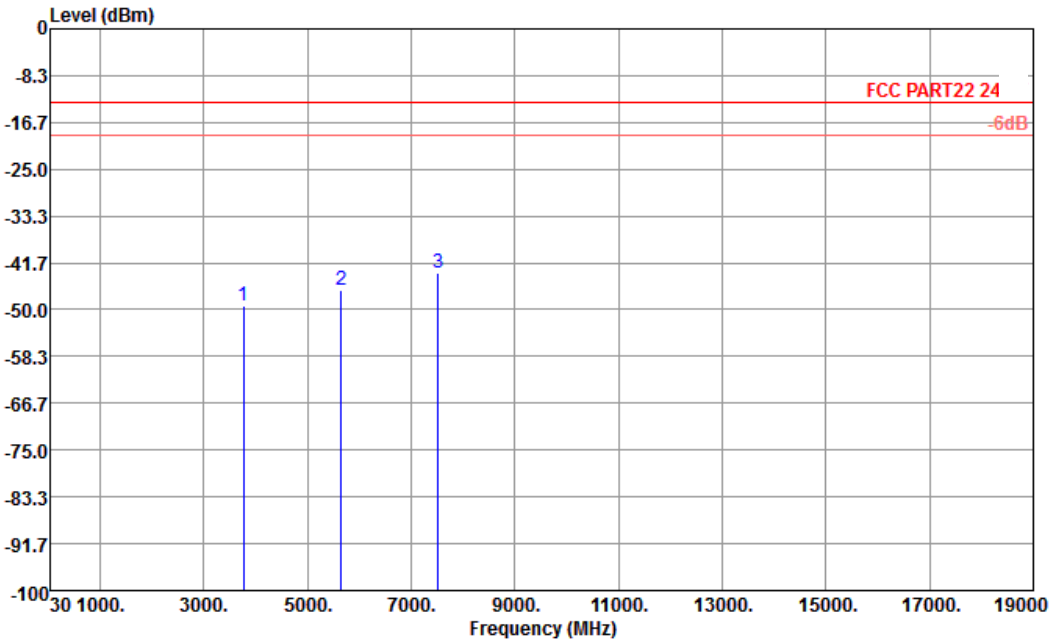

Site : 03CH01-KS  
 Condition : FCC PART22 24 HF\_EIRP\_FACTOR130726 HORIZONTAL  
 EUT : (FG) 3N1490

Frequency ( MHz )	EIRP ( dBm )	Limit ( dBm )	Over Limit ( dB )	SPA Reading ( dBm )	S.G. Power ( dBm )	TX Cable loss ( dB )	TX Antenna Gain ( dBi )	Polarization ( H/V )	Result
3760	-49.22	-13	-36.22	-64.42	-55.60	0.78	7.16	H	Pass
5640	-46.46	-13	-33.46	-64.97	-55.00	1.04	9.58	H	Pass
7520	-43.34	-13	-30.34	-62.07	-53.45	1.35	11.46	H	Pass



<b>Band :</b>	GSM1900	<b>Temperature :</b>	22~23°C
<b>Test Mode :</b>	EDGE class 8 Link (8PSK)	<b>Relative Humidity :</b>	42~43%
<b>Test Engineer :</b>	Stone Gu	<b>Polarization :</b>	Vertical
<b>Remark :</b>	Spurious emissions within 30-1000MHz were found more than 20dB below limit line.		

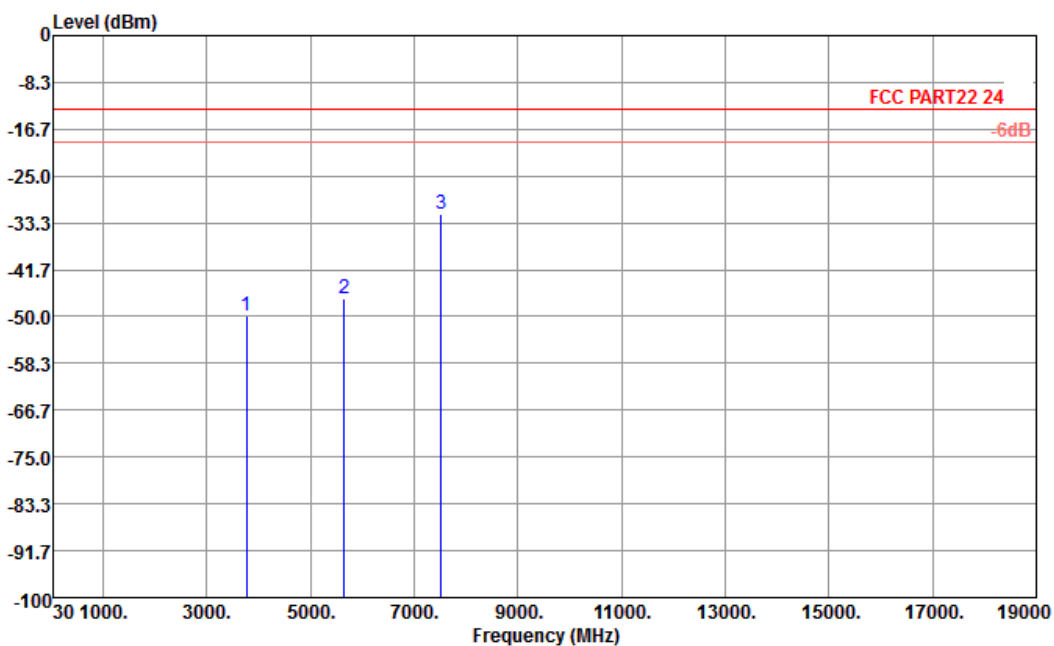

Site : 03CH01-KS  
 Condition : FCC PART22 24 HF\_EIRP\_FACTOR130726 VERTICAL  
 EUT : (FG) 3N1490

Frequency ( MHz )	EIRP ( dBm )	Limit ( dBm )	Over Limit ( dB )	SPA Reading ( dBm )	S.G. Power ( dBm )	TX Cable loss ( dB )	TX Antenna Gain ( dBi )	Polarization ( H/V )	Result
3760	-49.82	-13	-36.82	-65.19	-56.20	0.78	7.16	V	Pass
5640	-46.91	-13	-33.91	-64.49	-55.45	1.04	9.58	V	Pass
7520	-31.86	-13	-18.86	-50.4	-41.97	1.35	11.46	V	Pass



<b>Band :</b>	WCDMA Band V	<b>Temperature :</b>	22~23°C
<b>Test Mode :</b>	RMC 12.2Kbps Link (QPSK)	<b>Relative Humidity :</b>	42~43%
<b>Test Engineer :</b>	Stone Gu	<b>Polarization :</b>	Horizontal
<b>Remark :</b>	Spurious emissions within 30-1000MHz were found more than 20dB below limit line.		

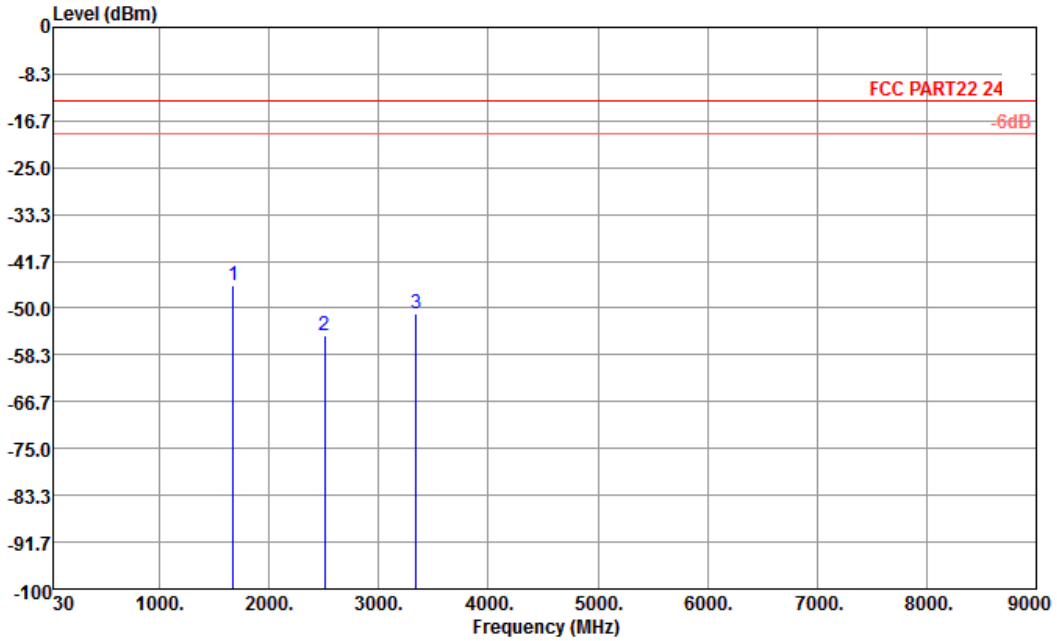

Site : 03CH01-KS  
 Condition : FCC PART22 24 HF\_EIRP\_FACTOR130726 HORIZONTAL  
 EUT : (FG) 3N1490

Frequency ( MHz )	ERP ( dBm )	Limit ( dBm )	Over Limit ( dB )	SPA Reading ( dBm )	S.G. Power ( dBm )	TX Cable loss ( dB )	TX Antenna Gain ( dBi )	Polarization ( H/V )	Result
1676	-46.01	-13	-33.01	-49.62	-46.66	0.57	3.37	H	Pass
2509	-54.84	-13	-41.84	-65.42	-57.07	0.78	5.16	H	Pass
3344	-50.86	-13	-37.86	-63.75	-54.50	0.87	6.66	H	Pass





<b>Band :</b>	WCDMA Band V	<b>Temperature :</b>	22~23°C
<b>Test Mode :</b>	RMC 12.2Kbps Link (QPSK)	<b>Relative Humidity :</b>	42~43%
<b>Test Engineer :</b>	Stone Gu	<b>Polarization :</b>	Vertical
<b>Remark :</b>	Spurious emissions within 30-1000MHz were found more than 20dB below limit line.		

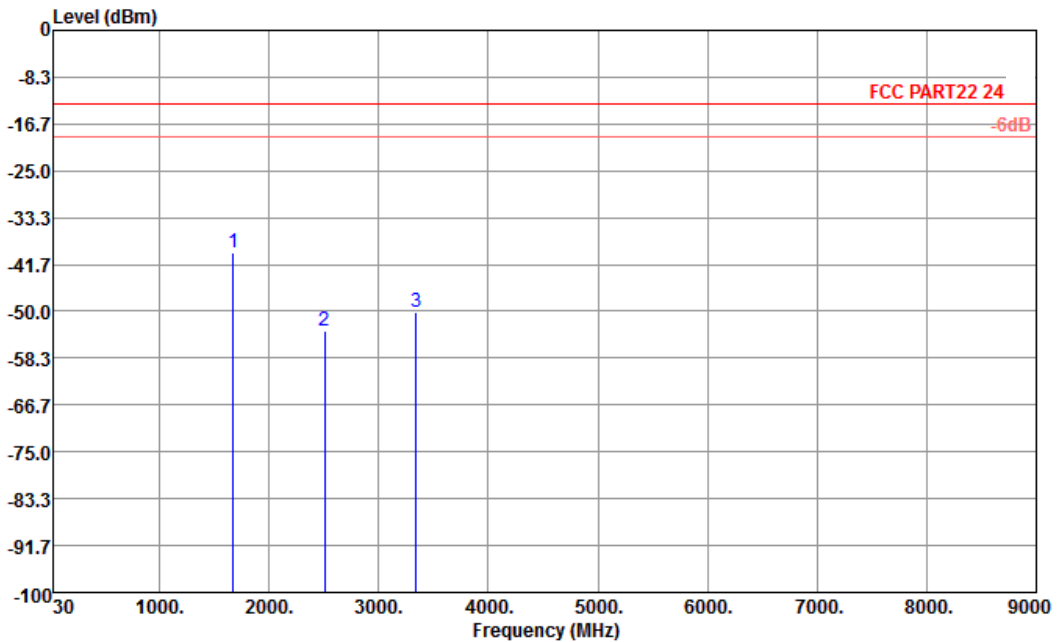

Site : 03CH01-KS  
 Condition : FCC PART22 24 HF\_EIRP\_FACTOR130726 VERTICAL  
 EUT : (FG) 3N1490

Frequency ( MHz )	ERP ( dBm )	Limit ( dBm )	Over Limit ( dB )	SPA Reading ( dBm )	S.G. Power ( dBm )	TX Cable loss ( dB )	TX Antenna Gain ( dBi )	Polarization ( H/V )	Result
1670	-39.56	-13	-26.56	-45.90	-40.21	0.57	3.37	V	Pass
2509	-53.36	-13	-40.36	-65.35	-55.59	0.78	5.16	V	Pass
3344	-50.10	-13	-37.10	-64.50	-53.74	0.87	6.66	V	Pass



<b>Band :</b>	WCDMA Band II	<b>Temperature :</b>	22~23°C
<b>Test Mode :</b>	RMC 12.2Kbps Link (QPSK)	<b>Relative Humidity :</b>	42~43%
<b>Test Engineer :</b>	Stone Gu	<b>Polarization :</b>	Horizontal
<b>Remark :</b>	Spurious emissions within 30-1000MHz were found more than 20dB below limit line.		

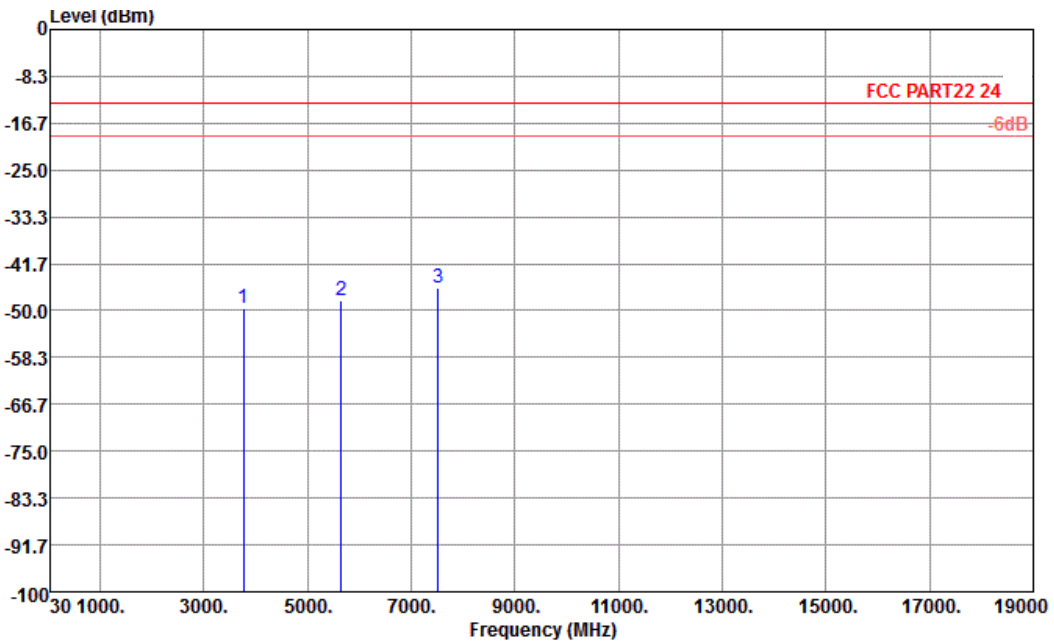

Site : 03CH01-KS  
 Condition : FCC PART22 24 HF\_EIRP\_FACTOR130726 HORIZONTAL  
 EUT : (FG) 3N1490

Frequency ( MHz )	EIRP ( dBm )	Limit ( dBm )	Over Limit ( dB )	SPA Reading ( dBm )	S.G. Power ( dBm )	TX Cable loss ( dB )	TX Antenna Gain ( dBi )	Polarization ( H/V )	Result
3760	-49.65	-13	-36.65	-64.78	-56.03	0.78	7.16	H	Pass
5640	-48.22	-13	-35.22	-66.40	-56.76	1.04	9.58	H	Pass
7520	-46.00	-13	-33.00	-64.56	-56.11	1.35	11.46	H	Pass



<b>Band :</b>	WCDMA Band II	<b>Temperature :</b>	22~23°C
<b>Test Mode :</b>	RMC 12.2Kbps Link (QPSK)	<b>Relative Humidity :</b>	42~43%
<b>Test Engineer :</b>	Stone Gu	<b>Polarization :</b>	Vertical
<b>Remark :</b>	Spurious emissions within 30-1000MHz were found more than 20dB below limit line.		

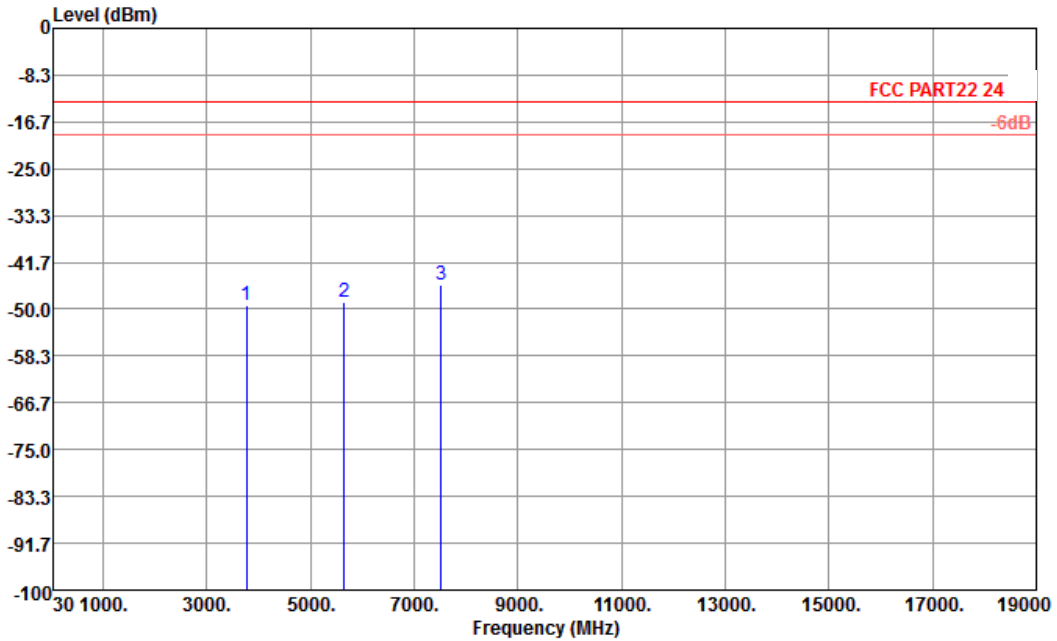

Site : 03CH01-KS  
 Condition : FCC PART22 24 HF\_EIRP\_FACTOR130726 VERTICAL  
 EUT : (FG) 3N1490

Frequency ( MHz )	EIRP ( dBm )	Limit ( dBm )	Over Limit ( dB )	SPA Reading ( dBm )	S.G. Power ( dBm )	TX Cable loss ( dB )	TX Antenna Gain ( dBi )	Polarization ( H/V )	Result
3760	-49.37	-13	-36.37	-64.8	-55.75	0.78	7.16	V	Pass
5640	-48.71	-13	-35.71	-66.06	-57.25	1.04	9.58	V	Pass
7520	-45.60	-13	-32.60	-63.61	-55.71	1.35	11.46	V	Pass

## 3.8 Frequency Stability Measurement

### 3.8.1 Description of Frequency Stability Measurement

The frequency stability shall be measured by variation of ambient temperature and variation of primary supply voltage to ensure that the fundamental emission stays within the authorized frequency block. The frequency stability of the transmitter shall be maintained within  $\pm 0.00025\%$  ( $\pm 2.5\text{ppm}$ ) of the center frequency.

### 3.8.2 Measuring Instruments

The measuring equipment is listed in the section 4 of this test report.

### 3.8.3 Test Procedures for Temperature Variation

1. The EUT was set up in the thermal chamber and connected with the base station.
2. With power OFF, the temperature was decreased to  $-30^{\circ}\text{C}$  and the EUT was stabilized before testing. Power was applied and the maximum change in frequency was recorded within one minute.
3. With power OFF, the temperature was raised in  $10^{\circ}\text{C}$  step up to  $50^{\circ}\text{C}$ . The EUT was stabilized at each step for at least half an hour. Power was applied and the maximum frequency change was recorded within one minute.

### 3.8.4 Test Procedures for Voltage Variation

1. The EUT was placed in a temperature chamber at  $25\pm 5^{\circ}\text{C}$  and connected with the base station.
2. The power supply voltage to the EUT was varied from BEP to 115% of the nominal value measured at the input to the EUT.
3. The variation in frequency was measured for the worst case.

### 3.8.5 Test Setup

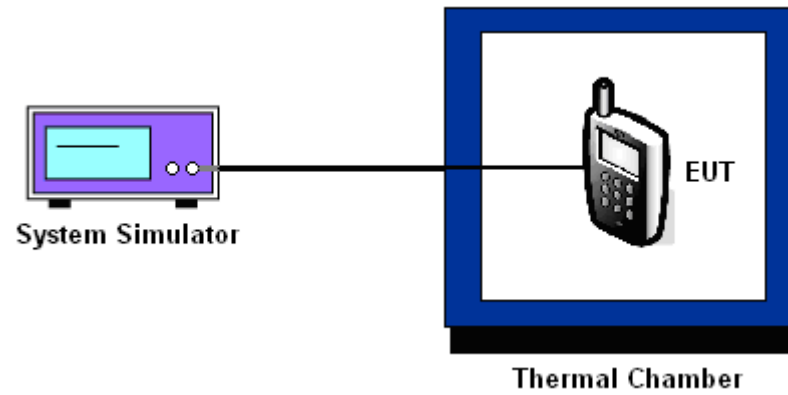

3.8.6 Test Result of Temperature Variation

Band :	GSM 850	Channel :	189
Limit (ppm) :	2.5	Frequency :	836.4 MHz

Temperature (°C)	GSM		EDGE class 8		Result
	Freq. Dev. (Hz)	Deviation (ppm)	Freq. Dev. (Hz)	Deviation (ppm)	
-30	-28	-0.03	-31	-0.04	PASS
-20	-26	-0.03	-28	-0.03	
-10	-18	-0.02	-22	-0.03	
0	-15	-0.02	-19	-0.02	
10	-13	-0.02	-10	-0.01	
20	8	0.01	6	+0.01	
30	11	0.01	5	+0.01	
40	12	0.01	-9	-0.01	
50	16	0.02	-10	-0.01	

Band :	GSM 1900	Channel :	661
Limit (ppm) :	2.5	Frequency :	1880.0 MHz

Temperature (°C)	GSM		EDGE class 8		Result
	Freq. Dev. (Hz)	Deviation (ppm)	Freq. Dev. (Hz)	Deviation (ppm)	
-30	-46	-0.02	-56	-0.03	PASS
-20	-44	-0.02	-51	-0.03	
-10	-49	-0.03	-44	-0.02	
0	-40	-0.02	-46	-0.02	
10	-38	-0.02	-40	-0.02	
20	-34	-0.02	-36	-0.02	
30	-29	-0.02	-33	-0.02	
40	-31	-0.02	25	+0.01	
50	40	0.02	34	+0.02	



<b>Band :</b>	WCDMA Band V	<b>Channel :</b>	4182
<b>Limit (ppm) :</b>	2.5	<b>Frequency :</b>	836.4 MHz

Temperature (°C)	RMC 12.2Kbps		Result
	Freq. Dev. (Hz)	Deviation (ppm)	
-30	-31	-0.04	PASS
-20	-25	-0.03	
-10	20	+0.02	
0	18	+0.02	
10	16	+0.02	
20	-14	-0.02	
30	13	+0.02	
40	5	+0.01	
50	8	+0.01	

<b>Band :</b>	WCDMA Band II	<b>Channel :</b>	9400
<b>Limit (ppm) :</b>	2.5	<b>Frequency :</b>	1880.0 MHz

Temperature (°C)	RMC 12.2Kbps		Result
	Freq. Dev. (Hz)	Deviation (ppm)	
-30	-50	-0.03	PASS
-20	-49	-0.03	
-10	44	+0.02	
0	41	+0.02	
10	39	+0.02	
20	-38	-0.02	
30	-36	-0.02	
40	-28	-0.01	
50	30	+0.02	

3.8.7 Test Result of Voltage Variation

Band & Channel	Mode	Voltage (Volt)	Freq. Dev. (Hz)	Deviation (ppm)	Limit (ppm)	Result
GSM 850 CH189	GSM	3.8	8	+0.01	2.5	PASS
		BEP	15	+0.02		
		4.35	-11	-0.01		
	EDGE class 8	3.8	12	+0.01		
		BEP	-18	-0.02		
		4.35	16	+0.02		
GSM 1900 CH661	GSM	3.8	38	+0.02		
		BEP	40	+0.02		
		4.35	-39	-0.02		
	EDGE class 8	3.8	44	+0.02		
		BEP	35	+0.02		
		4.35	46	+0.02		
WCDMA Band V CH4182	RMC 12.2Kbps	3.8	-16	-0.02		
		BEP	-11	-0.01		
		4.35	-12	-0.01		
WCDMA Band II CH9400	RMC 12.2Kbps	3.8	40	+0.02		
		BEP	-46	-0.02		
		4.35	-50	-0.03		

Note:

1. Normal Voltage = 3.8V.
2. Battery End Point (BEP) = 3.6 V.





## 4 List of Measuring Equipment

Instrument	Manufacturer	Model No.	Serial No.	Characteristics	Calibration Date	Test Date	Due Date	Remark
Spectrum Analyzer	R&S	FSP40	100319	9kHz~40GHz	Dec. 29, 2012	Nov. 25, 2013	Dec. 28, 2013	Conducted (TH01-KS)
Power Meter	Agilent	E4418B	MY45107368	N/A	Jul.16, 2013	Nov. 25, 2013	Jul.15, 2014	Conducted (TH01-KS)
Power Sensor	Agilent	N9304A H18	MY41498364	1nW~100mW (-60~+20dBm)	Sep. 14, 2013	Nov. 25, 2013	Sep. 13, 2014	Conducted (TH01-KS)
Thermal Chamber	Ten Billion	TTC-B3S	TBN-960502	N/A	Dec. 29, 2012	Nov. 25, 2013	Dec. 28, 2013	Conducted (TH01-KS)
EMI Test Receiver	R&S	ESCI	100534	9kHz~3GHz	Nov. 07, 2013	Nov. 23, 2013	Nov. 06, 2014	Radiation (03CH01-KS)
Spectrum Analyzer	R&S	FSP30	101399	9kHz~30GHz	May 23, 2013	Nov. 23, 2013	May 22, 2014	Radiation (03CH01-KS)
Bilog Antenna	SCHAFFNER	CBL6112D	23182	25MHz~2GHz	Dec. 07, 2012	Nov. 23, 2013	Dec. 06, 2013	Radiation (03CH01-KS)
Double Ridge Horn Antenna	EMCO	3117	75959	1GHz~18GHz	Dec. 07, 2012	Nov. 23, 2013	Dec. 06, 2013	Radiation (03CH01-KS)
Amplifier	com-power	PA-103A	161069	1MHz~1GHz	May 23, 2013	Nov. 23, 2013	May 22, 2014	Radiation (03CH01-KS)
Amplifier	Agilent	8449B	3008A02370	1GHz~26.5GHz	Dec. 29, 2012	Nov. 23, 2013	Dec. 28, 2013	Radiation (03CH01-KS)
Active Horn Antenna	com-power	AHA-118	701023	1GHz~18GHz	Nov. 06, 2013	Nov. 23, 2013	Nov. 05, 2014	Radiation (03CH01-KS)
SHF-EHF Horn	Schwarzbeck	BBHA 9170	BBHA170249	15GHz~40GHz	Nov. 22, 2013	Nov. 23, 2013	Nov. 21, 2014	Radiation (03CH01-KS)
Turn Table	MF	MF7802	N/A	0 ~ 360 degree	N/A	Nov. 23, 2013	N/A	Radiation (03CH01-KS)
Antenna Mast	MF	MF7802	N/A	1 m - 4 m	N/A	Nov. 23, 2013	N/A	Radiation (03CH01-KS)



## 5 Uncertainty of Evaluation

### Uncertainty of Radiated Emission Measurement (30 MHz ~ 1000 MHz)

Measuring Uncertainty for a Level of Confidence of 95% ( $U = 2Uc(y)$ )	2.54
---	------