



FCC RF Test Report

APPLICANT : Acer Incorporated
EQUIPMENT : Smart HandHeld
BRAND NAME : Acer
MODEL NAME : S56
MARKETING NAME : Liquid Jade S
FCC ID : HLZDMS56
STANDARD : FCC Part 15 Subpart C §15.247
CLASSIFICATION : (DTS) Digital Transmission System

The product was received on Sep. 24, 2014 and testing was completed on Nov. 10, 2014. We, SPORTON INTERNATIONAL (KUNSHAN) INC., would like to declare that the tested sample has been evaluated in accordance with the test procedures and has been in compliance with the applicable technical standards.

The test results in this report apply exclusively to the tested model / sample. Without written approval of SPORTON INTERNATIONAL (KUNSHAN) INC., the test report shall not be reproduced except in full.

Reviewed by: Joseph Lin / Supervisor

Approved by: Jones Tsai / Manager



SPORTON INTERNATIONAL (KUNSHAN) INC.
No. 3-2, PingXiang Road, Kunshan, Jiangsu Province, P. R. China



TABLE OF CONTENTS

REVISION HISTORY..... 3

SUMMARY OF TEST RESULT 4

1 GENERAL DESCRIPTION 5

 1.1 Applicant 5

 1.2 Manufacturer 5

 1.3 Product Feature of Equipment Under Test 5

 1.4 Product Specification subjective to this standard 5

 1.5 Modification of EUT 6

 1.6 Testing Location 6

 1.7 Applicable Standards 6

2 TEST CONFIGURATION OF EQUIPMENT UNDER TEST 7

 2.1 Carrier Frequency Channel 7

 2.2 Pre-Scanned RF Power 8

 2.3 Test Mode 9

 2.4 Connection Diagram of Test System 10

 2.5 Support Unit used in test configuration and system 11

 2.6 EUT Operation Test Setup 11

 2.7 Measurement Results Explanation Example 12

3 TEST RESULT 13

 3.1 6dB and 99% Bandwidth Measurement 13

 3.2 Output Power Measurement 16

 3.3 Power Spectral Density Measurement 19

 3.4 Conducted Band Edges and Spurious Emission Measurement 22

 3.5 Radiated Band Edges and Spurious Emission Measurement 35

 3.6 AC Conducted Emission Measurement 57

 3.7 Antenna Requirements 61

4 LIST OF MEASURING EQUIPMENT 62

5 UNCERTAINTY OF EVALUATION 63

APPENDIX A. SETUP PHOTOGRAPHS



SUMMARY OF TEST RESULT

Report Section	FCC Rule	IC Rule	Description	Limit	Result	Remark
3.1	15.247(a)(2)	RSS-210 A8.2(a)	6dB Bandwidth	$\geq 0.5\text{MHz}$	Pass	-
3.1	-	RSS-Gen 4.6.1	99% Bandwidth	-	Pass	-
3.2	15.247(b)	RSS-210 A8.4	Power Output Measurement	$\leq 30\text{dBm}$	Pass	-
3.3	15.247(e)	RSS-210 A8.2(b)	Power Spectral Density	$\leq 8\text{dBm}/3\text{kHz}$	Pass	-
3.4	15.247(d)	RSS-210 A8.5	Conducted Band Edges	$\leq 20\text{dBc}$	Pass	-
			Conducted Spurious Emission		Pass	-
3.5	15.247(d)	RSS-210 A8.5	Radiated Band Edges and Radiated Spurious Emission	15.209(a) & 15.247(d)	Pass	Under limit 4.75 dB at 2483.560 MHz
3.6	15.207	RSS-Gen 7.2.4	AC Conducted Emission	15.207(a)	Pass	Under limit 10.78 dB at 2.990 MHz
3.7	15.203 & 15.247(b)	RSS-210 A8.4	Antenna Requirement	N/A	Pass	-



1 General Description

1.1 Applicant

Acer Incorporated

8F., No. 88, Sec. 1, Xintai 5th Rd., Xizhi Dist., New Taipei City 22181, Taiwan (R.O.C)

1.2 Manufacturer

Shanghai Sunrise Simcom Limited

No. 888, Shengli Rd., Qingpu, Shanghai, P.R.China 201700

1.3 Product Feature of Equipment Under Test

Product Feature	
Equipment	Smart HandHeld
Brand Name	Acer
Model Name	S56
Marketing Name	Liquid Jade S
FCC ID	HLZDMS56
EUT supports Radios application	GSM/GPRS/EGPRS/ WCDMA/HSPA/HSPA+(DownlinkOnly)/LTE/ WLAN 2.4GHz 802.11b/g/n (HT20/HT40)/ Bluetooth v3.0 + EDR/Bluetooth v4.0 LE
EUT Stage	Identical Prototype

Remark: The above EUT's information was declared by manufacturer. Please refer to the specifications or user's manual for more detailed description.

1.4 Product Specification subjective to this standard

Product Specification subjective to this standard	
Tx/Rx Channel Frequency Range	802.11b/g/n : 2412 MHz ~ 2462 MHz
Maximum (Peak) Output Power to Antenna	802.11b : 16.89 dBm (0.0489 W) 802.11g : 19.15 dBm (0.0822 W) 802.11n HT20 : 18.75 dBm (0.0750 W) 802.11n HT40 : 19.54 dBm (0.0899 W)
99% Occupied Bandwidth	802.11b : 12.35MHz 802.11g : 16.40MHz 802.11n HT20 : 17.55MHz 802.11n HT40 : 36.10MHz
Antenna Type/Gain	802.11b/g/n : PIFA Antenna with gain -0.12 dBi
Type of Modulation	802.11b : DSSS (DBPSK / DQPSK / CCK) 802.11g/n : OFDM (BPSK / QPSK / 16QAM / 64QAM)



1.5 Modification of EUT

No modifications are made to the EUT during all test items.

1.6 Testing Location

Test Site	SPORTON INTERNATIONAL (KUNSHAN) INC.			
Test Site Location	No. 3-2, PingXiang Road, Kunshan, Jiangsu Province, P. R. China TEL: +86-0512-5790-0158 FAX: +86-0512-5790-0958			
Test Site No.	Sporton Site No.			FCC/IC Registration No.
	TH01-KS	03CH01-KS	CO01-KS	149928/4086E-1

1.7 Applicable Standards

According to the specifications of the manufacturer, the EUT must comply with the requirements of the following standards:

- FCC Part 15 Subpart C §15.247
- FCC KDB Publication No. 558074 D01 DTS Meas. Guidance v03r02
- ANSI C63.4-2003
- IC RSS-210 Issue 8
- IC RSS-Gen Issue 4
- NOTICE 2012-DRS0126

Remark:

1. All test items were verified and recorded according to the standards and without any deviation during the test.
2. This EUT has also been tested and complied with the requirements of FCC Part 15, Subpart B, recorded in a separate test report.
3. Per the section 2.2.3 of Notice of 2012-DRS0126, “ Receivers Excluded from Industry Canada Requirements”, only radiocommunication receivers operating in stand-alone mode within the band 30-960 MHz and scanner receivers are subject to Industry Canada requirements.



2 Test Configuration of Equipment Under Test

The EUT has been associated with peripherals and configuration operated in a manner tended to maximize its emission characteristics in a typical application. Frequency range investigated: conducted emission (150 kHz to 30 MHz) and radiated emission (9 kHz to the 10th harmonic of the highest fundamental frequency or to 40 GHz, whichever is lower). For radiated measurement, pre-scanned in three orthogonal panels, X, Y, Z. The worst cases (Z plane) were recorded in this report.

The final configuration from all the combinations and the worst-case data rates were investigated by measuring the maximum power across all the data rates and modulation modes under section 2.2.

Based on the worst configuration found above, the RF power setting is set individually to meet FCC compliance limit for the final conducted and radiated tests shown in section 2.3.

2.1 Carrier Frequency Channel

Frequency Band	Channel	Freq. (MHz)	Channel	Freq. (MHz)
2400-2483.5 MHz	1	2412	7	2442
	2	2417	8	2447
	3	2422	9	2452
	4	2427	10	2457
	5	2432	11	2462
	6	2437	-	-



2.2 Pre-Scanned RF Power

Preliminary tests were performed in different data rate and data rate associated with the highest power were chosen for full test shown in the following tables.

2.4GHz 802.11b RF Output Power (dBm)						
Power vs. Channel			Power vs. Data Rate			
Channel	Frequency (MHz)	Data Rate	Channel	2Mbps	5.5Mbps	11Mbps
		1Mbps				
CH 01	2412 MHz	15.95	CH 06	16.60	16.84	16.72
CH 06	2437 MHz	16.89				
CH 11	2462 MHz	16.22				

2.4GHz 802.11g RF Output Power (dBm)										
Power vs. Channel			Power vs. Data Rate							
Channel	Frequency (MHz)	Data Rate	Channel	9Mbps	12Mbps	18Mbps	24Mbps	36Mbps	48Mbps	54Mbps
		6Mbps								
CH 01	2412 MHz	18.60	CH 06	18.90	19.08	19.02	18.87	18.85	19.09	19.12
CH 06	2437 MHz	19.15								
CH 11	2462 MHz	18.68								

2.4GHz 802.11n HT20 RF Output Power (dBm)										
Power vs. Channel			Power vs. MCS Index							
Channel	Frequency (MHz)	MCS Index	Channel	MCS1	MCS2	MCS3	MCS4	MCS5	MCS6	MCS7
		MCS0								
CH 01	2412 MHz	18.21	CH 06	18.54	18.53	18.42	18.34	18.51	18.68	18.51
CH 06	2437 MHz	18.75								
CH 11	2462 MHz	18.60								

2.4GHz 802.11n HT40 RF Output Power (dBm)										
Power vs. Channel			Power vs. MCS Index							
Channel	Frequency (MHz)	MCS Index	Channel	MCS1	MCS2	MCS3	MCS4	MCS5	MCS6	MCS7
		MCS0								
CH 03	2422 MHz	19.16	CH 06	19.21	19.01	18.87	18.51	19.22	18.97	19.50
CH 06	2437 MHz	19.54								
CH 09	2452 MHz	19.18								



2.3 Test Mode

Final results of test modes, data rates and test channels are shown as following table.

Test Cases				
	Test Items	Mode	Data Rate	Test Channel
Conducted TCs	6dB and 99% BW Power Spectral Density	802.11b	1 Mbps	1/6/11
		802.11g	6 Mbps	1/6/11
		802.11n HT20	MCS0	1/6/11
		802.11n HT40	MCS0	3/6/9
	Output Power	802.11b	1 Mbps	1/6/11
		802.11g	6 Mbps	1/6/11
		802.11n HT20	MCS0	1/6/11
		802.11n HT40	MCS0	3/6/9
	Conducted Band Edge	802.11b	1 Mbps	1/11
		802.11g	6 Mbps	1/11
		802.11n HT20	MCS0	1/11
		802.11n HT40	MCS0	3/9
	Conducted Spurious Emission	802.11b	1 Mbps	1/6/11
		802.11g	6 Mbps	1/6/11
		802.11n HT20	MCS0	1/6/11
		802.11n HT40	MCS0	3/6/9
Radiated TCs	Radiated Band Edge	802.11b	1 Mbps	1/11
		802.11g	6 Mbps	1/11
		802.11n HT20	MCS0	1/11
		802.11n HT40	MCS0	3/9
	Radiated Spurious Emission	802.11b	1 Mbps	1/6/11
		802.11g	6 Mbps	1/6/11
		802.11n HT20	MCS0	1/6/11
		802.11n HT40	MCS0	3/6/9
Test Cases				
AC Conducted Emission	Mode 1 : GSM850 Idle + Bluetooth Link + WLAN Link + USB Cable (Charging from Adapter) + Earphone + SIM1			
Remark: For Radiated TCs, all the test modes are performed with adapter, earphone and USB cable.				

2.4 Connection Diagram of Test System

<WLAN Tx Mode>

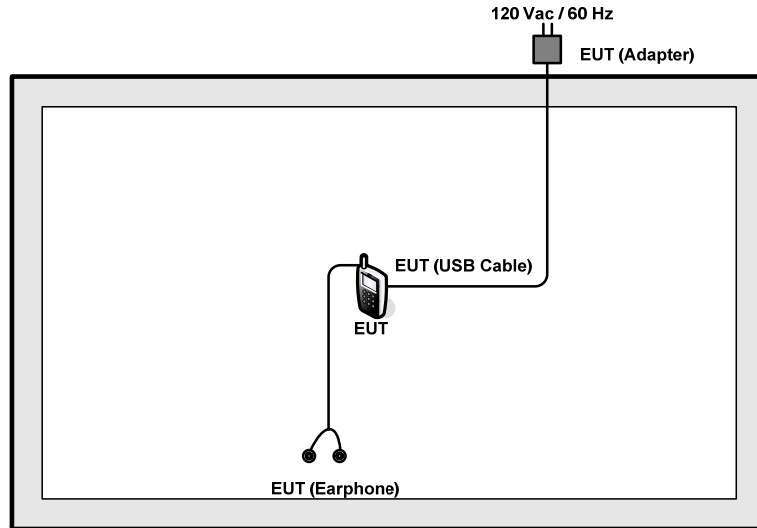

<AC Conducted Emission Mode>

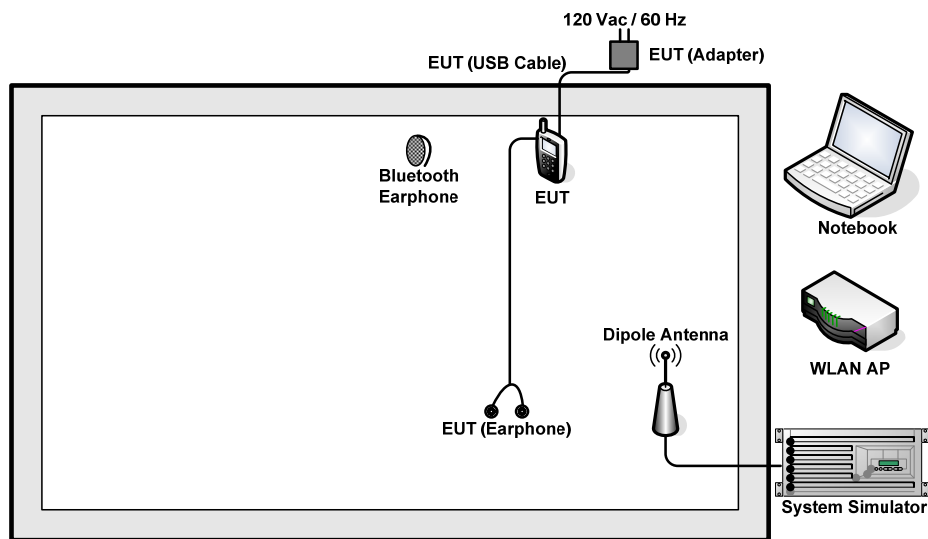



2.5 Support Unit used in test configuration and system

Item	Equipment	Trade Name	Model Name	FCC ID	Data Cable	Power Cord
1.	System Simulator	R&S	CMU 200	N/A	N/A	Unshielded, 1.8 m
2.	Notebook	Lenovo	G480	PRC4	N/A	shielded cable DC O/P 1.8 m unshielded AC I/P cable 1.8 m
3.	Bluetooth Earphone	Lenovo	LBH505	N/A	N/A	N/A
4.	WLAN AP	D-Link	DIR-855	KA2DIR855A2	N/A	Unshielded, 1.8m

2.6 EUT Operation Test Setup

For WLAN function, the engineering test program was provided and enabled to make EUT continuous transmit/receive.

For AC power line conducted emissions, the EUT was set to connect with the WLAN AP under large package sizes transmission.



2.7 Measurement Results Explanation Example

For all conducted test items:

The offset level is set in the spectrum analyzer to compensate the RF cable loss between EUT conducted output port and spectrum analyzer. With the offset compensation, the spectrum analyzer reading level is exactly the EUT RF output level.

Example :

The spectrum analyzer offset is derived from RF cable loss.

Offset = RF cable loss.

Following shows an offset computation example with cable loss 6.0 dB.

Offset(dB) = RF cable loss(dB).
= 6.0 (dB)

3 Test Result

3.1 6dB and 99% Bandwidth Measurement

3.1.1 Limit of 6dB and 99% Bandwidth

The minimum 6 dB bandwidth shall be at least 500 kHz.

3.1.2 Measuring Instruments

The measuring equipment is listed in the section 4 of this test report.

3.1.3 Test Procedures

1. The testing follows FCC KDB Publication No. 558074 DTS D01 Meas. Guidance v03r02.
2. The RF output of EUT was connected to the spectrum analyzer by RF cable and attenuator. The path loss was compensated to the results for each measurement.
3. Set to the maximum power setting and enable the EUT transmit continuously.
4. Make the measurement with the spectrum analyzer's resolution bandwidth (RBW) = 100 kHz. Set the Video bandwidth (VBW) = 300 kHz. In order to make an accurate measurement. The 6 dB bandwidth must be greater than 500 kHz.
5. For 99% Bandwidth Measurement, the spectrum analyzer's resolution bandwidth (RBW) = 1MHz and set the Video bandwidth (VBW) = 3MHz.
6. Measure and record the results in the test report.

3.1.4 Test Setup

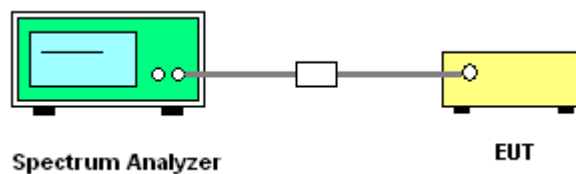



3.1.5 Test Result of 6dB and 99% Occupied Bandwidth

Test Band :	2.4GHz	Temperature :	24~25°C
Test Engineer :	Issac Song	Relative Humidity :	49~51%

Mod.	Data Rate	N _{TX}	Channel	Freq. (MHz)	99% Bandwidth (MHz)	6dB Bandwidth (MHz)	6dB Bandwidth Min. Limit (MHz)	Pass/Fail
11b	1Mbps	1	1	2412	12.25	8.58	0.5	Pass
11b	1Mbps	1	6	2437	12.35	9.04	0.5	Pass
11b	1Mbps	1	11	2462	11.50	8.52	0.5	Pass
11g	6Mbps	1	1	2412	16.40	16.00	0.5	Pass
11g	6Mbps	1	6	2437	16.40	15.74	0.5	Pass
11g	6Mbps	1	11	2462	16.30	15.06	0.5	Pass
HT20	MCS0	1	1	2412	17.55	16.90	0.5	Pass
HT20	MCS0	1	6	2437	17.55	17.14	0.5	Pass
HT20	MCS0	1	11	2462	17.50	15.04	0.5	Pass
HT40	MCS0	1	3	2422	36.40	35.44	0.5	Pass
HT40	MCS0	1	6	2437	36.08	31.28	0.5	Pass
HT40	MCS0	1	9	2452	36.48	35.32	0.5	Pass

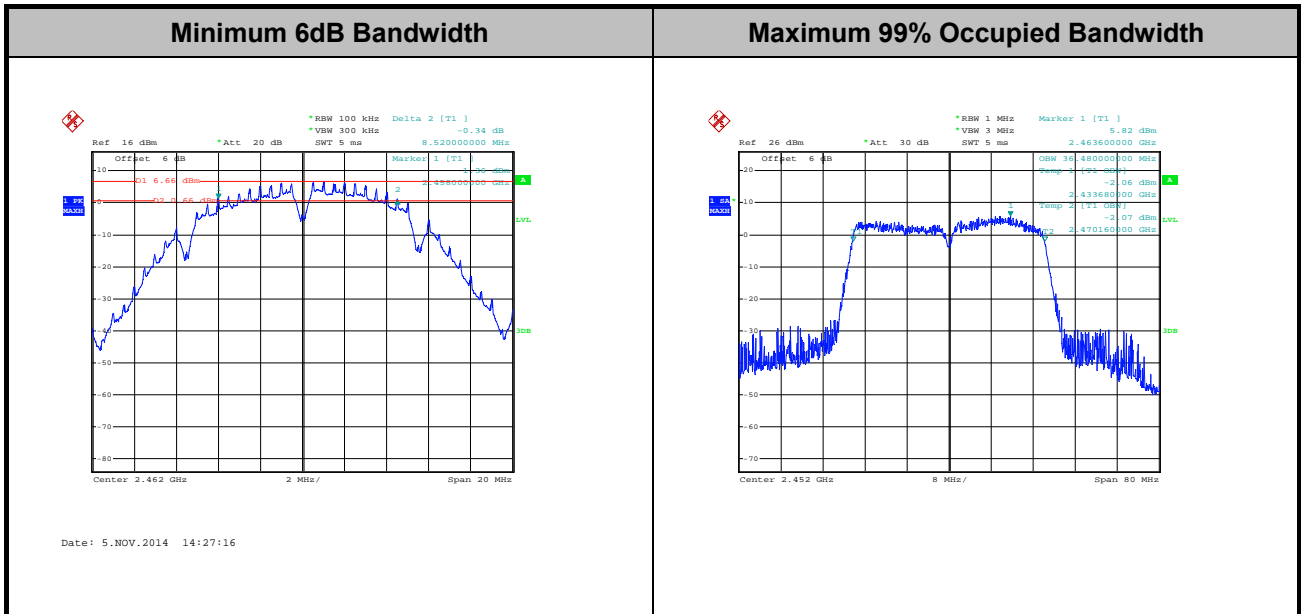

Note: The occupied channel bandwidth is maintained within the band of operation for all of the modulations.

3.2 Output Power Measurement

3.2.1 Limit of Output Power

For systems using digital modulation in the 2400-2483.5MHz, the limit for peak output power is 30dBm. If transmitting Antenna of directional gain greater than 6dBi are used the peak output power from the intentional radiator shall be reduced below the above stated value by the amount in dB that the directional gain of the Antenna exceeds 6 dBi. In case of point-to-point operation, the limit has to be reduced by 1dB for every 3dB that the directional gain of the Antenna exceeds 6dBi.

3.2.2 Measuring Instruments

The measuring equipment is listed in the section 4 of this test report.

3.2.3 Test Procedures

1. The testing follows the Measurement Procedure of FCC KDB No. 558074 DTS D01 Meas. Guidance v03r02.
2. The RF output of EUT was connected to the power meter by RF cable and attenuator. The path loss was compensated to the results for each measurement.
3. Set to the maximum power setting and enable the EUT transmit continuously.
4. Measure the conducted output power and record the results in the test report.

3.2.4 Test Setup

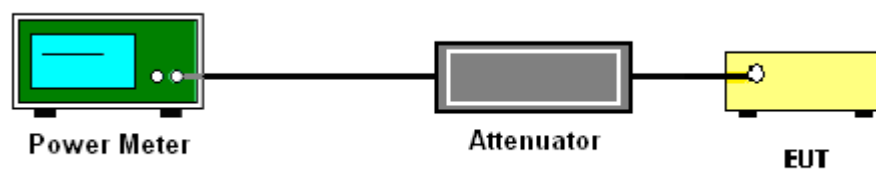



3.2.5 Test Result of Peak Output Power

Test Mode :	2.4GHz	Temperature :	24~25°C
Test Engineer :	Issac Song	Relative Humidity :	49~51%

Mod.	Data Rate	N _{TX}	Channel	Freq. (MHz)	RF Output Power (dBm)	Power Limit (dBm)	DG (dBi)	Pass/Fail
11b	1Mbps	1	1	2412	15.95	30	-0.12	Pass
11b	1Mbps	1	6	2437	16.89	30	-0.12	Pass
11b	1Mbps	1	11	2462	16.22	30	-0.12	Pass
11g	6Mbps	1	1	2412	18.60	30	-0.12	Pass
11g	6Mbps	1	6	2437	19.15	30	-0.12	Pass
11g	6Mbps	1	11	2462	18.68	30	-0.12	Pass
HT20	MCS0	1	1	2412	18.21	30	-0.12	Pass
HT20	MCS0	1	6	2437	18.75	30	-0.12	Pass
HT20	MCS0	1	11	2462	18.60	30	-0.12	Pass
HT40	MCS0	1	3	2422	19.16	30	-0.12	Pass
HT40	MCS0	1	6	2437	19.54	30	-0.12	Pass
HT40	MCS0	1	9	2452	19.18	30	-0.12	Pass

Note: Measured power (dBm) has offset with cable loss.



3.2.6 Test Result of Average output Power (Reporting Only)

Test Mode :	2.4GHz	Temperature :	24~25°C
Test Engineer :	Issac Song	Relative Humidity :	49~51%

Mod.	Data Rate	N _{TX}	Channel	Freq. (MHz)	Duty Factor (dB)	Average Output Power (dBm)	Power Limit (dBm)	DG (dBi)	Pass/Fail
11b	1Mbps	1	1	2412	0.08	12.83	30	-0.12	Pass
11b	1Mbps	1	6	2437	0.08	13.82	30	-0.12	Pass
11b	1Mbps	1	11	2462	0.08	13.12	30	-0.12	Pass
11g	6Mbps	1	1	2412	0.51	8.80	30	-0.12	Pass
11g	6Mbps	1	6	2437	0.51	9.59	30	-0.12	Pass
11g	6Mbps	1	11	2462	0.51	8.91	30	-0.12	Pass
HT20	MCS0	1	1	2412	0.56	8.11	30	-0.12	Pass
HT20	MCS0	1	6	2437	0.56	9.04	30	-0.12	Pass
HT20	MCS0	1	11	2462	0.56	8.68	30	-0.12	Pass
HT40	MCS0	1	3	2422	1.01	7.63	30	-0.12	Pass
HT40	MCS0	1	6	2437	1.01	9.42	30	-0.12	Pass
HT40	MCS0	1	9	2452	1.01	8.02	30	-0.12	Pass

Note: Measured power (dBm) has offset with cable loss and duty factor.

3.3 Power Spectral Density Measurement

3.3.1 Limit of Power Spectral Density

The peak power spectral density shall not be greater than 8dBm in any 3kHz band at any time interval of continuous transmission.

3.3.2 Measuring Instruments

The measuring equipment is listed in the section 4 of this test report.

3.3.3 Test Procedures

1. The testing follows Measurement Procedure 10.2 Method PKPSD of FCC KDB Publication No. 558074 D01 DTS Meas. Guidance v03r02
2. The RF output of EUT was connected to the spectrum analyzer by RF cable and attenuator. The path loss was compensated to the results for each measurement.
3. Set to the maximum power setting and enable the EUT transmit continuously.
4. Make the measurement with the spectrum analyzer's resolution bandwidth (RBW) = 3 kHz. Video bandwidth VBW = 10 kHz In order to make an accurate measurement, set the span to 1.5 times DTS Channel Bandwidth. (6dB BW)
5. Detector = peak, Sweep time = auto couple, Trace mode = max hold, Allow trace to fully stabilize. Use the peak marker function to determine the maximum power level.
6. Measure and record the results in the test report.

3.3.4 Test Setup

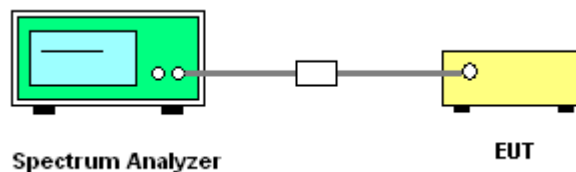



3.3.5 Test Result of Power Spectral Density

Test Mode :	2.4GHz	Temperature :	24~25°C
Test Engineer :	Issac Song	Relative Humidity :	49~51%

Mod.	Data Rate	N _{TX}	Channel	Freq. (MHz)	Peak Power Density (dBm/3kHz)	Max. Limits (dBm/3kHz)	DG (dBi)	Pass/Fail
11b	1Mbps	1	1	2412	-6.93	8	-0.12	Pass
11b	1Mbps	1	6	2437	-7.08	8	-0.12	Pass
11b	1Mbps	1	11	2462	5.25	8	-0.12	Pass
11g	6Mbps	1	1	2412	-15.65	8	-0.12	Pass
11g	6Mbps	1	6	2437	-14.59	8	-0.12	Pass
11g	6Mbps	1	11	2462	-13.06	8	-0.12	Pass
HT20	MCS0	1	1	2412	-20.18	8	-0.12	Pass
HT20	MCS0	1	6	2437	-16.63	8	-0.12	Pass
HT20	MCS0	1	11	2462	-15.12	8	-0.12	Pass
HT40	MCS0	1	3	2422	-19.60	8	-0.12	Pass
HT40	MCS0	1	6	2437	-15.43	8	-0.12	Pass
HT40	MCS0	1	9	2452	-17.87	8	-0.12	Pass

Note: Measured power density (dBm) has offset with cable loss.

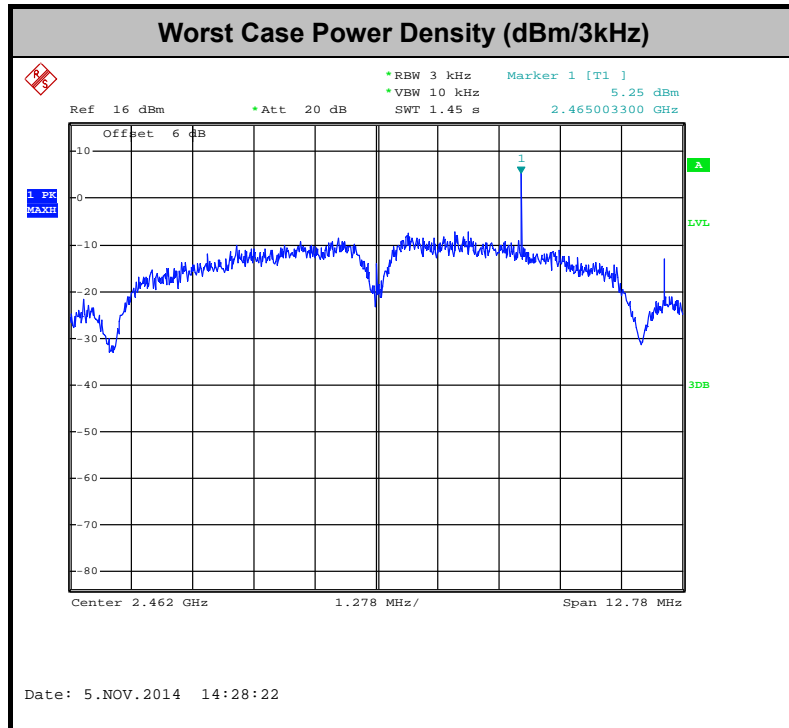

3.4 Conducted Band Edges and Spurious Emission Measurement

3.4.1 Limit of Conducted Band Edges and Spurious Emission Measurement

In any 100 kHz bandwidth outside of the authorized frequency band, the emissions which fall in the non-restricted bands shall be attenuated at least 20 dB / 30dB relative to the maximum PSD level in 100 kHz by RF conducted measurement and radiated emissions which fall in the restricted bands, as defined in Section 15.205(a), must also comply with the radiated emission limits specified in Section 15.209(a).

3.4.2 Measuring Instruments

The measuring equipment is listed in the section 4 of this test report.

3.4.3 Test Procedures

1. The testing follows FCC KDB Publication No. 558074 D01 DTS Meas. Guidance v03r02.
2. The RF output of EUT was connected to the spectrum analyzer by RF cable and attenuator. The path loss was compensated to the results for each measurement.
3. Set to the maximum power setting and enable the EUT transmit continuously.
4. Set RBW = 100 kHz, VBW=300 kHz, Peak Detector. Unwanted Emissions measured in any 100 kHz bandwidth outside of the authorized frequency band shall be attenuated by at least 20 dB relative to the maximum in-band peak PSD level in 100 kHz when maximum peak conducted output power procedure is used. If the transmitter complies with the conducted power limits based on the use of RMS averaging over a time interval, the attenuation required under this paragraph shall be 30 dB instead of 20 dB per 15.247(d).
5. Measure and record the results in the test report.
6. The RF fundamental frequency should be excluded against the limit line in the operating frequency band.

3.4.4 Test Setup

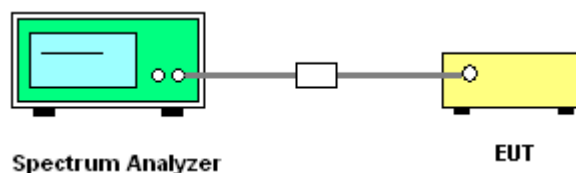



3.4.5 Test Result of Conducted Band Edges and Spurious Emission

Test Mode :	802.11b	Temperature :	24~25°C
Test Band :	2.4GHz Low	Relative Humidity :	49~51%
Test Channel :	01	Test Engineer :	Issac Song

WLAN 802.11b Channel 01

100kHz PSD reference Level

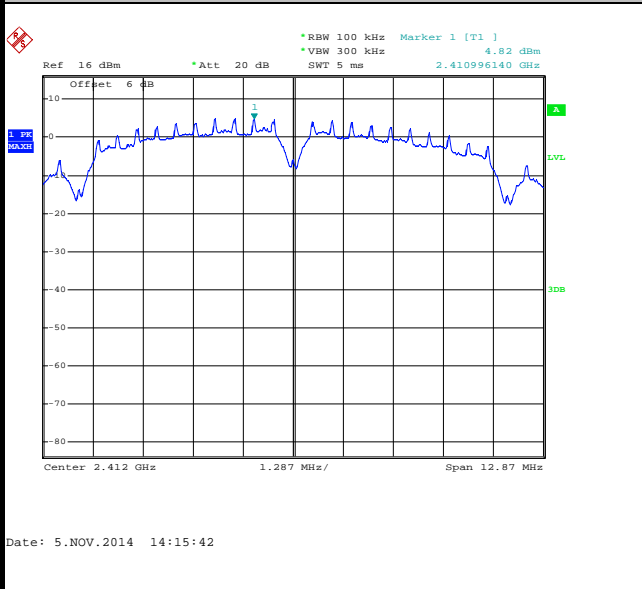

Low Channel Plot

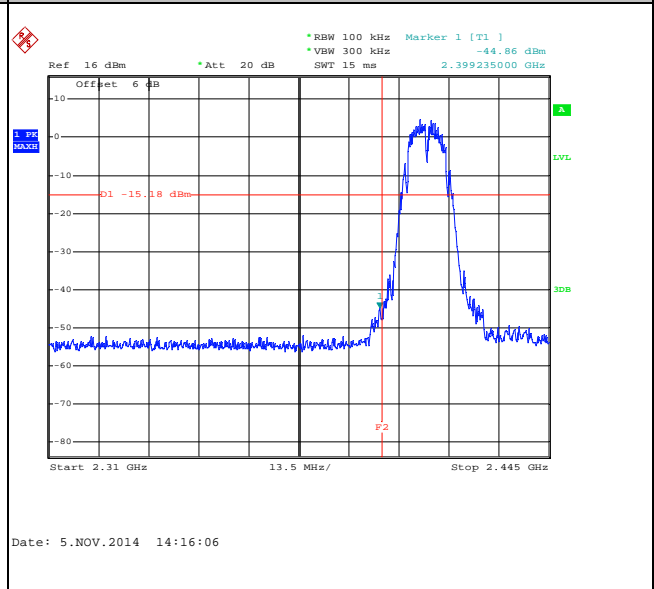

Spurious Emission 30MHz~3GHz

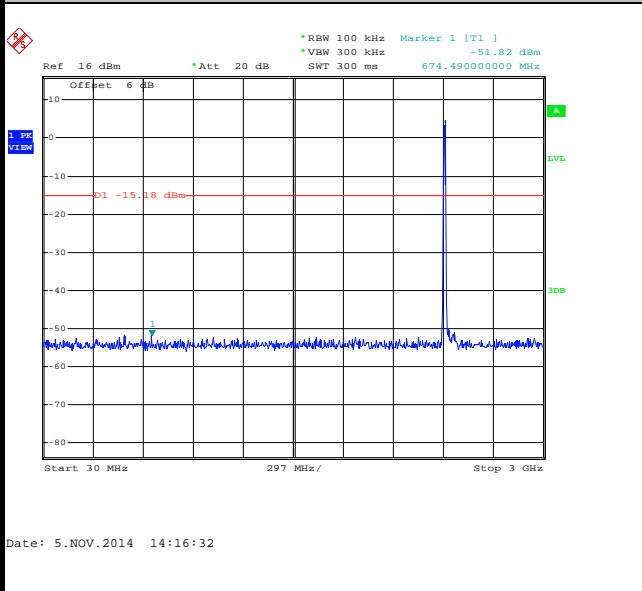

Spurious Emission 2GHz~25GHz

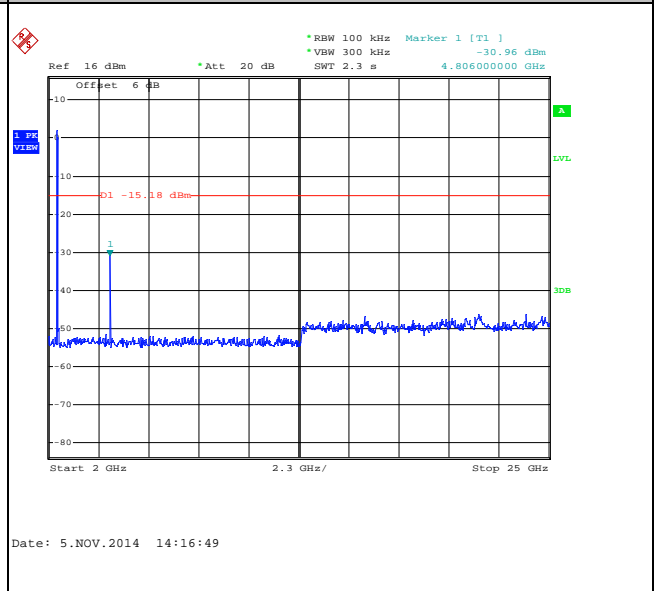



Test Mode :	802.11b	Temperature :	24~25°C
Test Band :	2.4GHz Mid	Relative Humidity :	49~51%
Test Channel :	06	Test Engineer :	Issac Song

WLAN 802.11b Channel 06

100kHz PSD reference Level

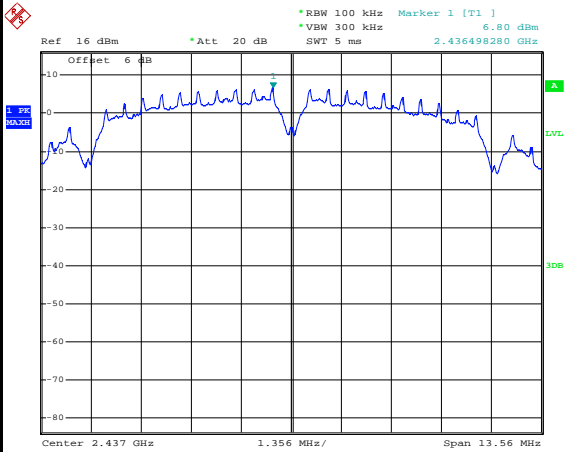

Date: 5.NOV.2014 14:23:57

Spurious Emission 30MHz~3GHz

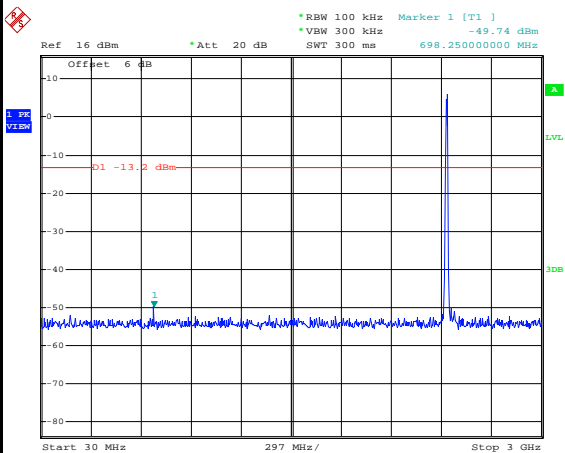

Date: 5.NOV.2014 14:24:19

Spurious Emission 2GHz~25GHz

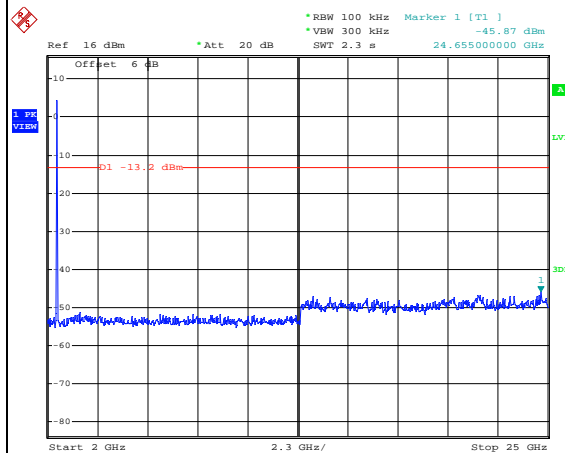

Date: 5.NOV.2014 14:24:37



Test Mode :	802.11b	Temperature :	24~25°C
Test Band :	2.4GHz High	Relative Humidity :	49~51%
Test Channel :	11	Test Engineer :	Issac Song

WLAN 802.11b Channel 11

100kHz PSD reference Level

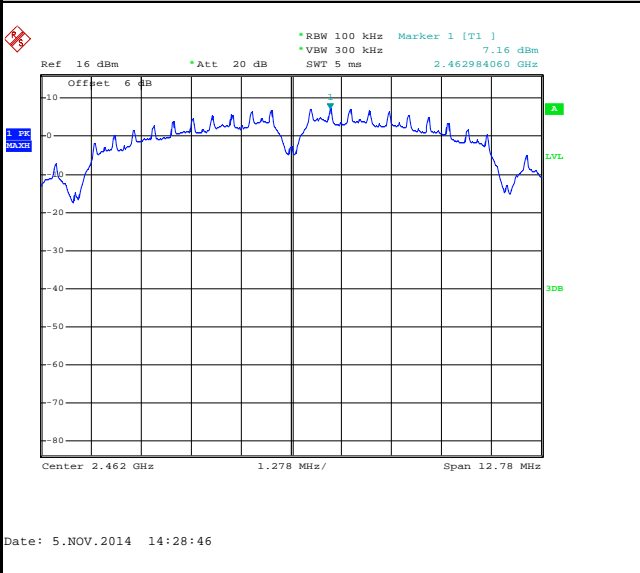

High Channel Plot

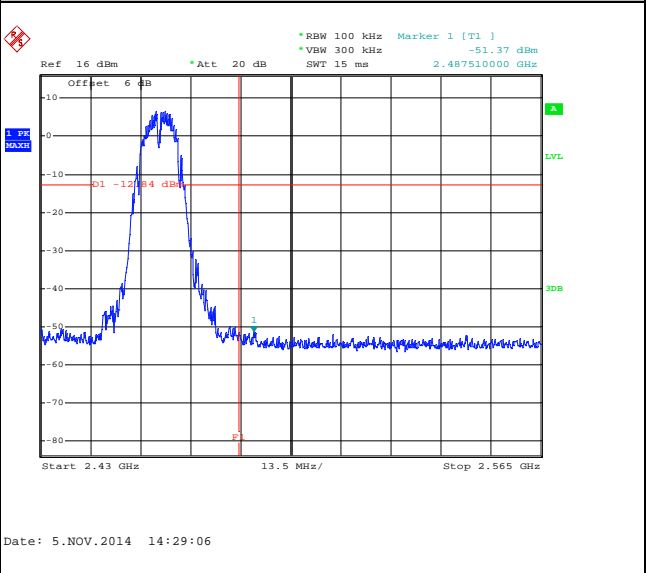

Spurious Emission 30MHz~3GHz

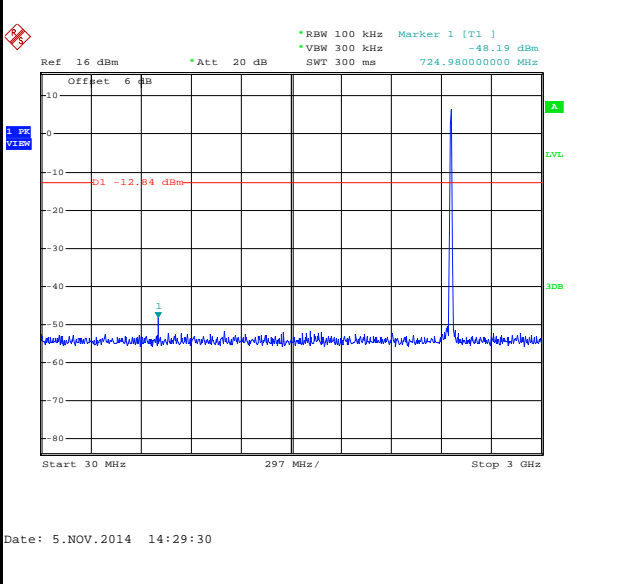

Spurious Emission 2GHz~25GHz

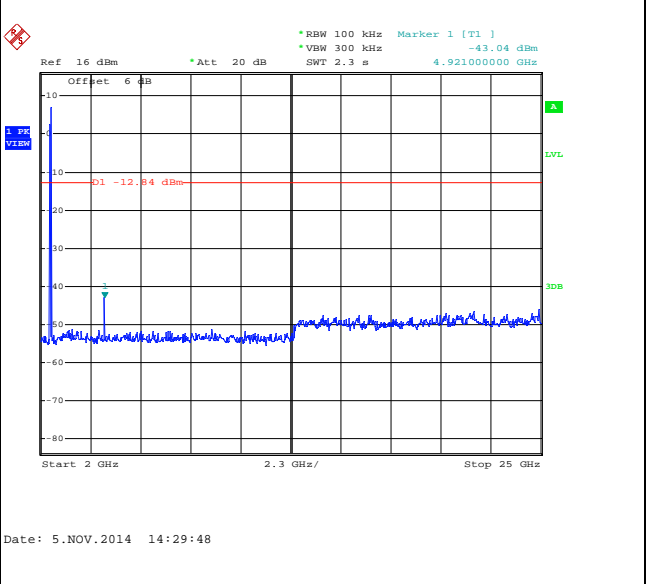



Test Mode :	802.11g	Temperature :	24~25°C
Test Band :	2.4GHz Low	Relative Humidity :	49~51%
Test Channel :	01	Test Engineer :	Issac Song

WLAN 802.11g Channel 01

100kHz PSD reference Level

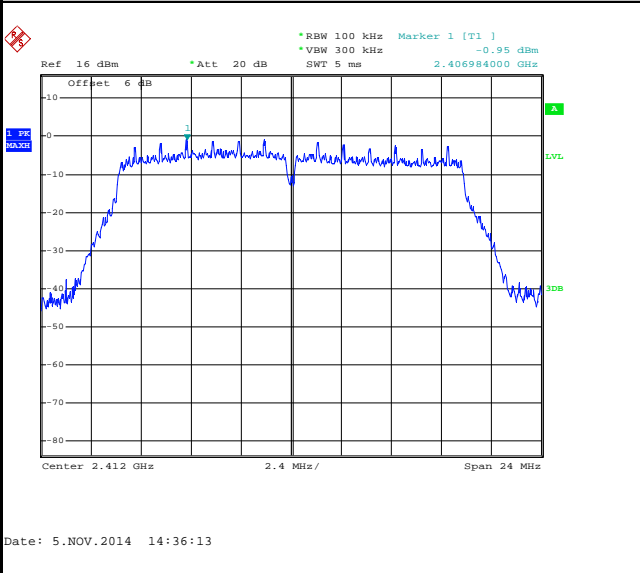

Low Channel Plot

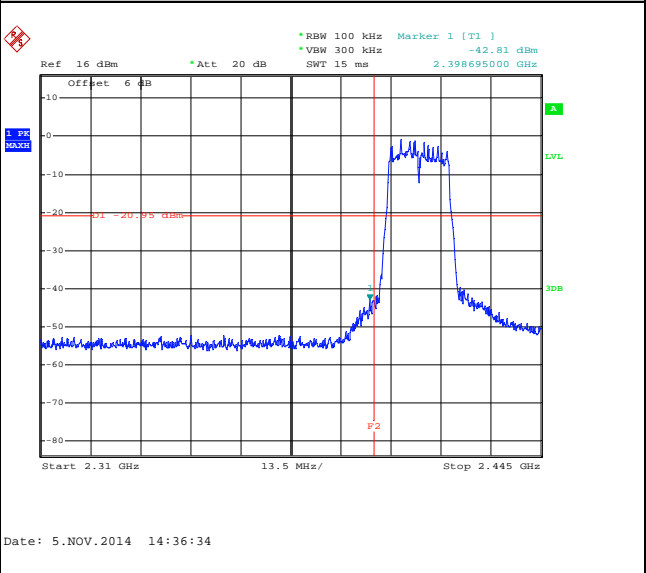

Spurious Emission 30MHz~3GHz

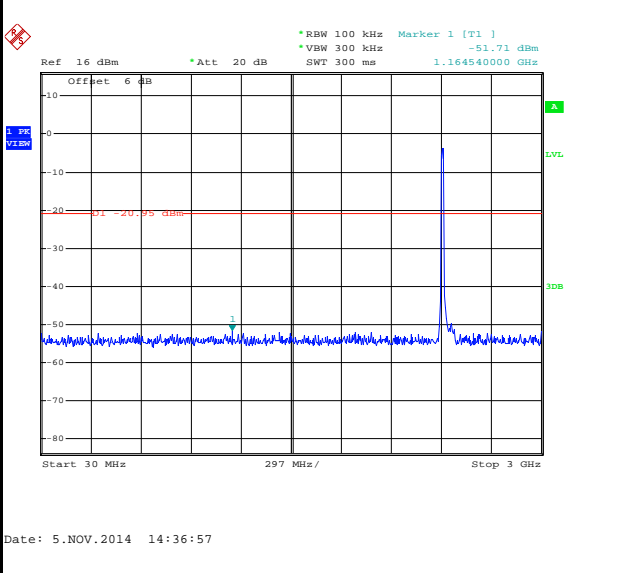

Spurious Emission 2GHz~25GHz

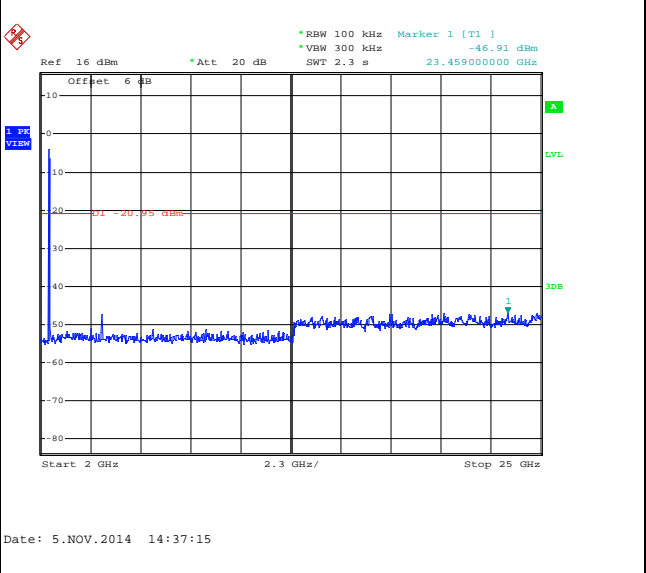



Test Mode :	802.11g	Temperature :	24~25°C
Test Band :	2.4GHz Mid	Relative Humidity :	49~51%
Test Channel :	06	Test Engineer :	Issac Song

WLAN 802.11g Channel 06

100kHz PSD reference Level

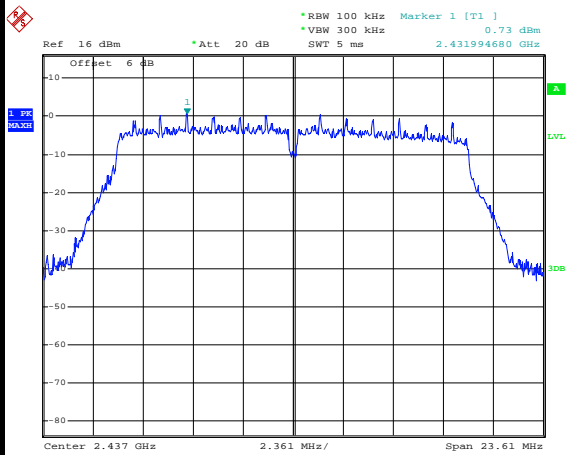

Date: 5.NOV.2014 14:41:10

Spurious Emission 30MHz~3GHz

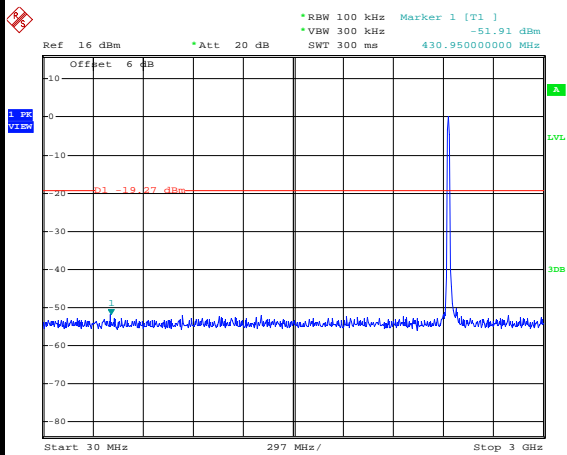

Date: 5.NOV.2014 14:41:34

Spurious Emission 2GHz~25GHz

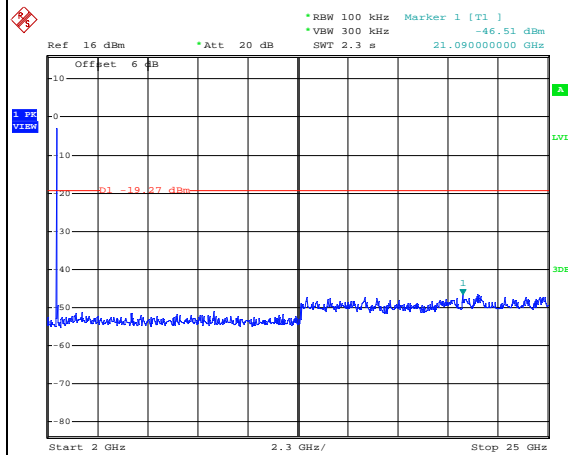

Date: 5.NOV.2014 14:41:52



Test Mode :	802.11g	Temperature :	24~25°C
Test Band :	2.4GHz High	Relative Humidity :	49~51%
Test Channel :	11	Test Engineer :	Issac Song

WLAN 802.11g Channel 11

100kHz PSD reference Level

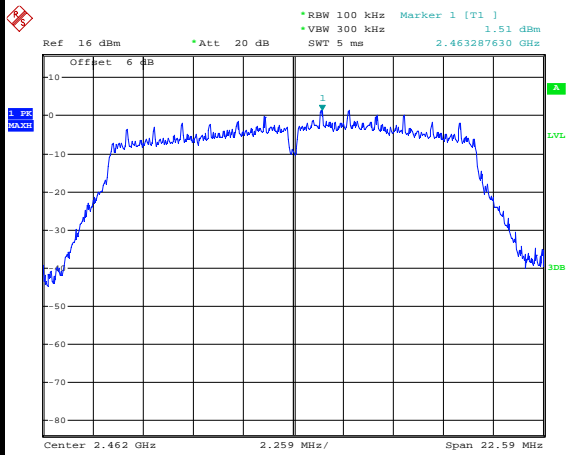

Date: 5.NOV.2014 14:45:05

High Channel Plot

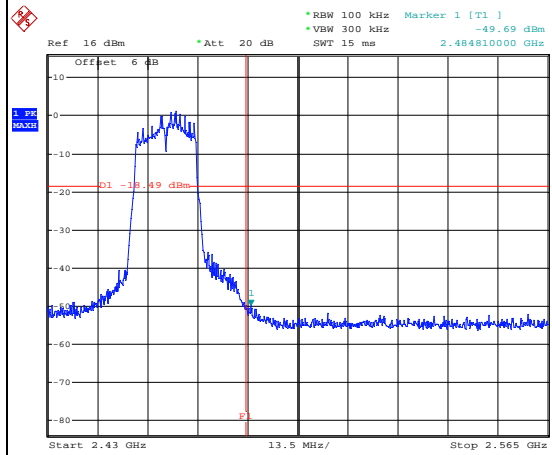

Date: 5.NOV.2014 14:45:23

Spurious Emission 30MHz~3GHz

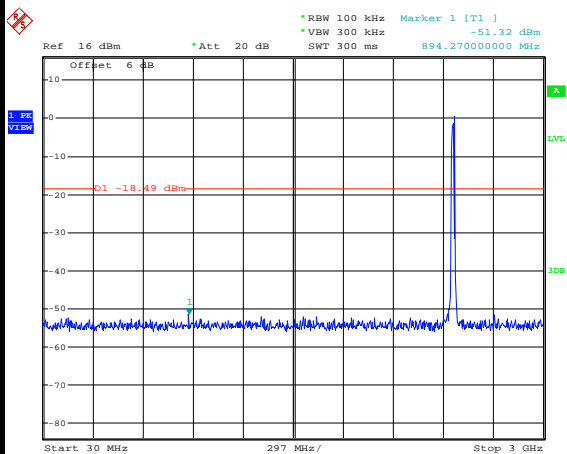

Date: 5.NOV.2014 14:45:49

Spurious Emission 2GHz~25GHz

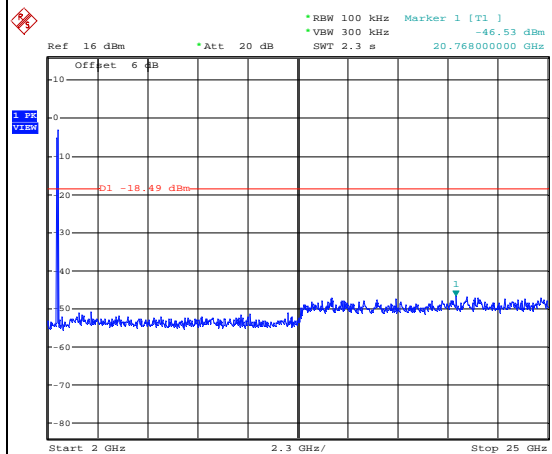

Date: 5.NOV.2014 14:46:07



Test Mode :	802.11n HT20	Temperature :	24~25°C
Test Band :	2.4GHz Low	Relative Humidity :	49~51%
Test Channel :	01	Test Engineer :	Issac Song

WLAN 802.11n HT20 Channel 01

100kHz PSD reference Level

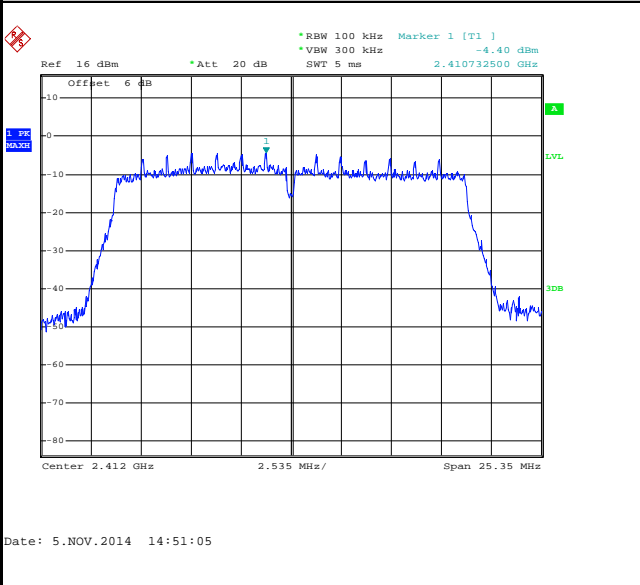

Low Channel Plot

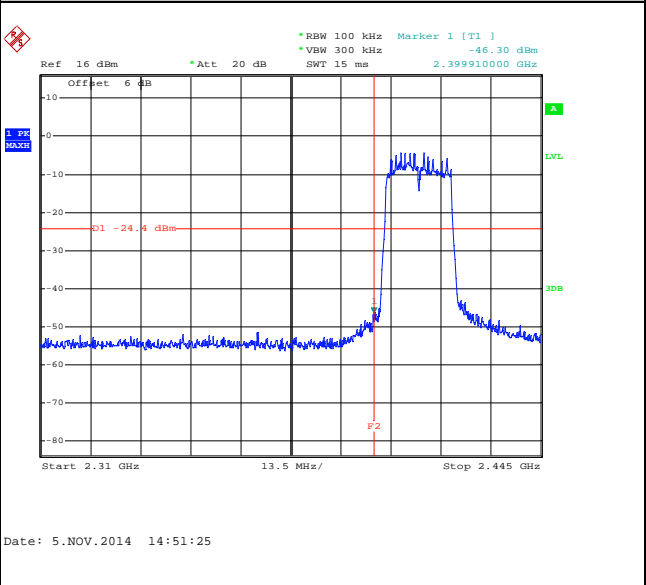

Spurious Emission 30MHz~3GHz

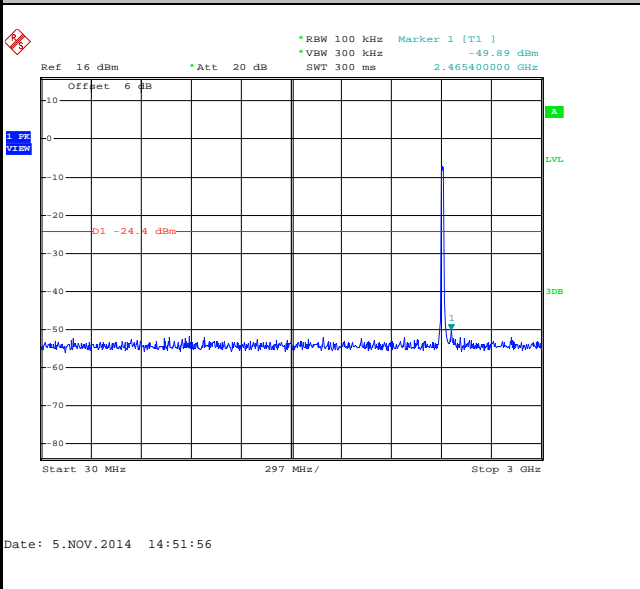

Spurious Emission 2GHz~25GHz

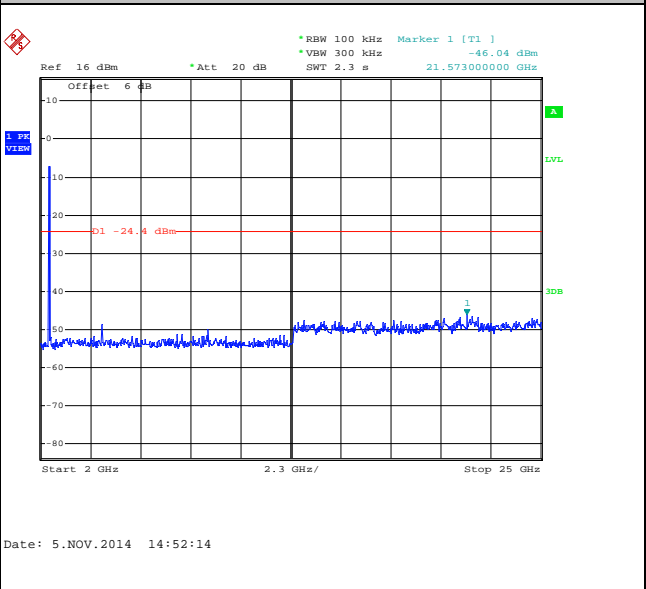



Test Mode :	802.11n HT20	Temperature :	24~25°C
Test Band :	2.4GHz Mid	Relative Humidity :	49~51%
Test Channel :	06	Test Engineer :	Issac Song

WLAN 802.11n HT20 Channel 06

100kHz PSD reference Level

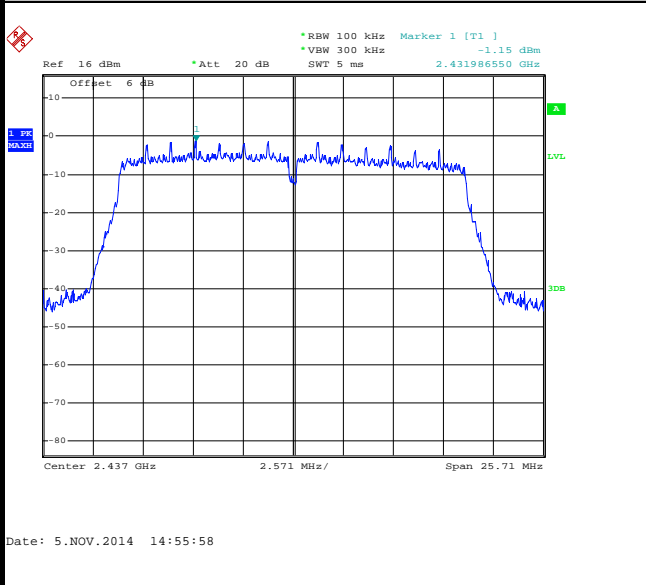

Spurious Emission 30MHz~3GHz

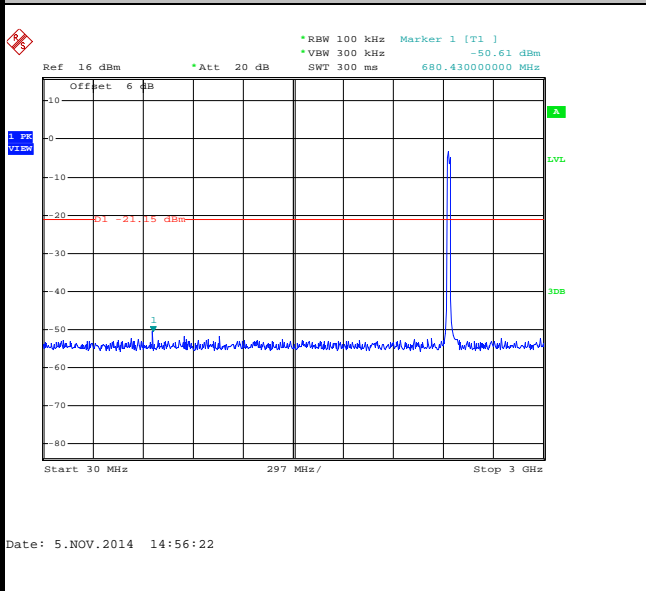

Spurious Emission 2GHz~25GHz

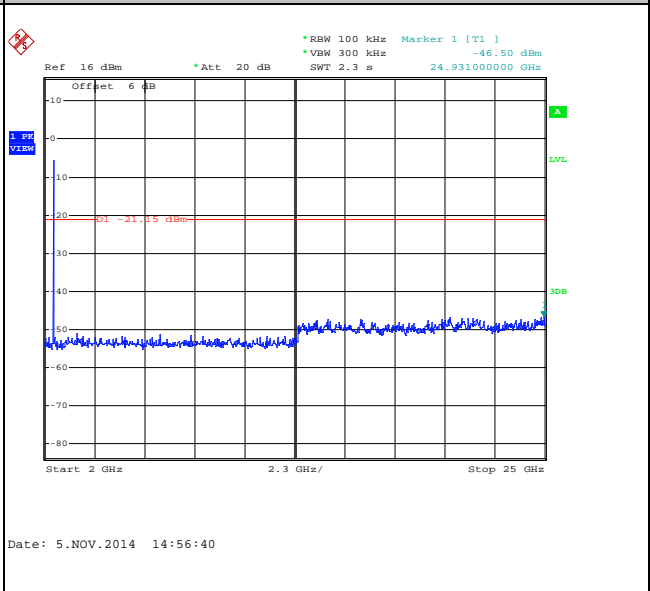



Test Mode :	802.11n HT20	Temperature :	24~25°C
Test Band :	2.4GHz High	Relative Humidity :	49~51%
Test Channel :	11	Test Engineer :	Issac Song

WLAN 802.11n HT20 Channel 11

100kHz PSD reference Level

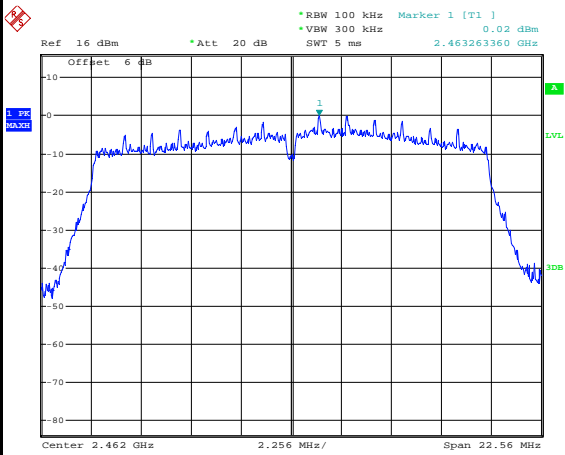

Date: 5.NOV.2014 15:03:10

High Channel Plot

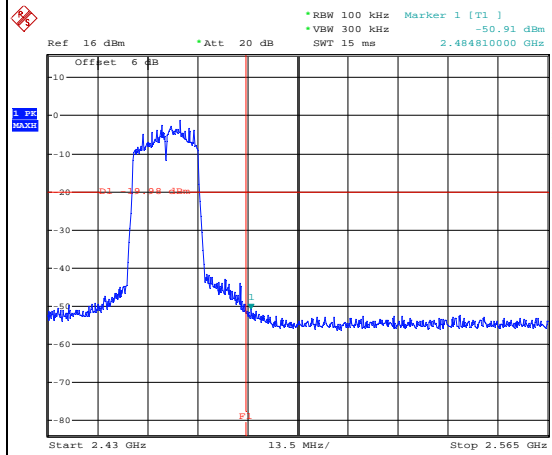

Date: 5.NOV.2014 15:03:31

Spurious Emission 30MHz~3GHz

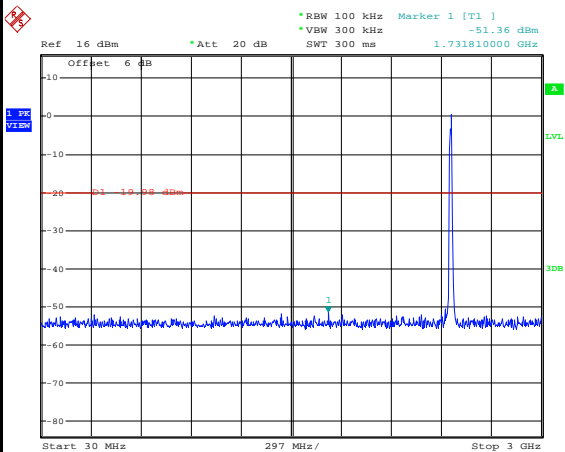

Date: 5.NOV.2014 15:03:55

Spurious Emission 2GHz~25GHz

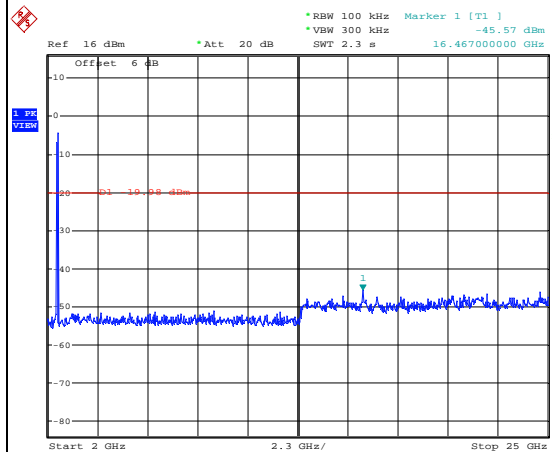

Date: 5.NOV.2014 15:04:12



Test Mode :	802.11n HT40	Temperature :	24~25°C
Test Band :	2.4GHz Low	Relative Humidity :	49~51%
Test Channel :	03	Test Engineer :	Issac Song

WLAN 802.11n HT40 Channel 03

100kHz PSD reference Level

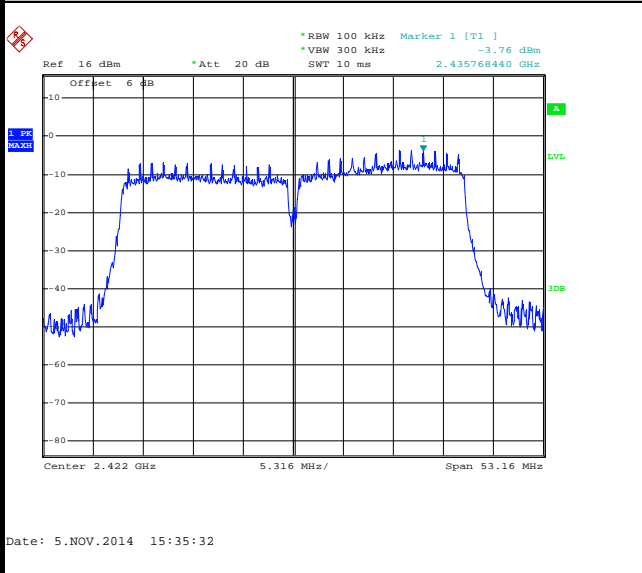

Low Channel Plot

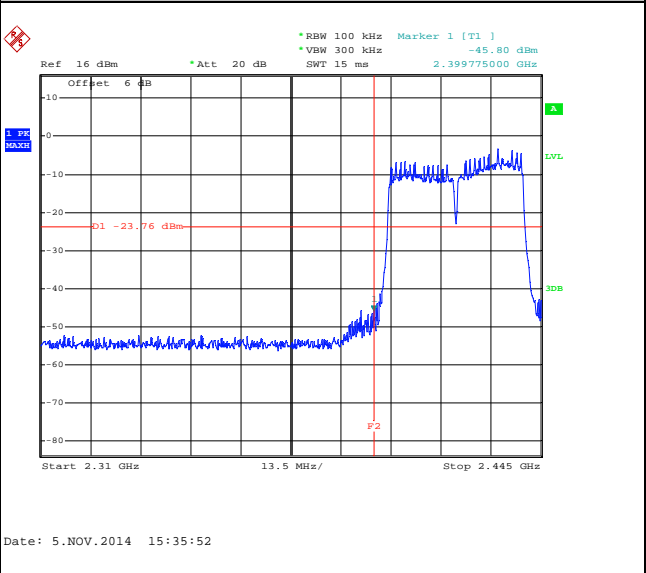

Spurious Emission 30MHz~3GHz

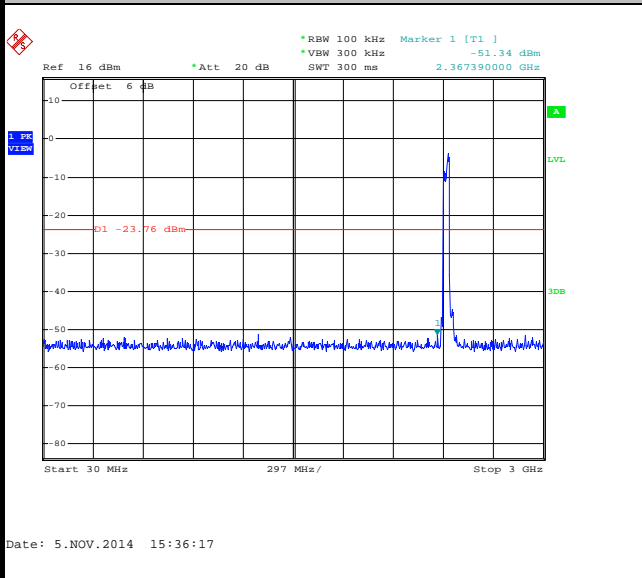

Spurious Emission 2GHz~25GHz

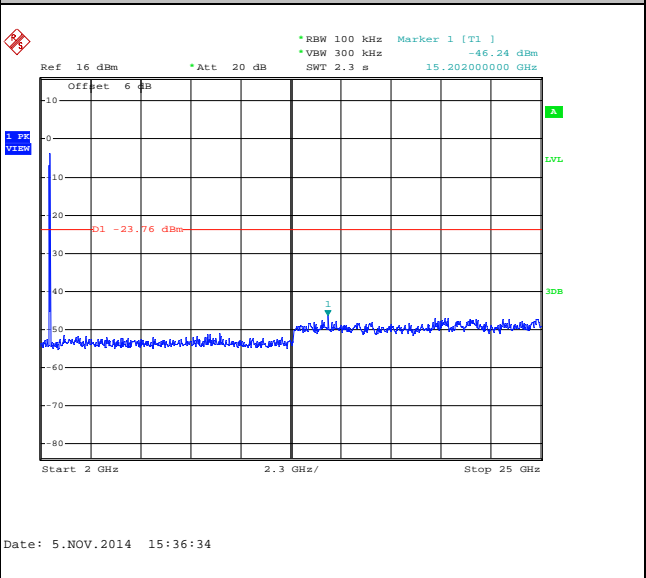



Test Mode :	802.11n HT40	Temperature :	24~25°C
Test Band :	2.4GHz Mid	Relative Humidity :	49~51%
Test Channel :	06	Test Engineer :	Issac Song

WLAN 802.11n HT40 Channel 06

100kHz PSD reference Level

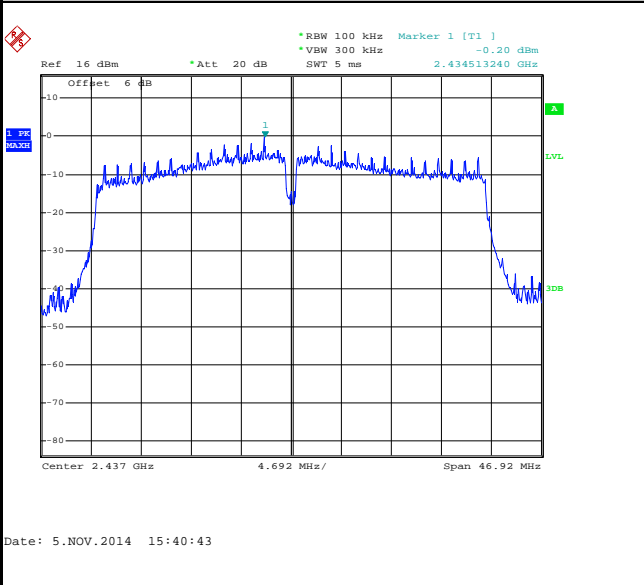

Spurious Emission 30MHz~3GHz

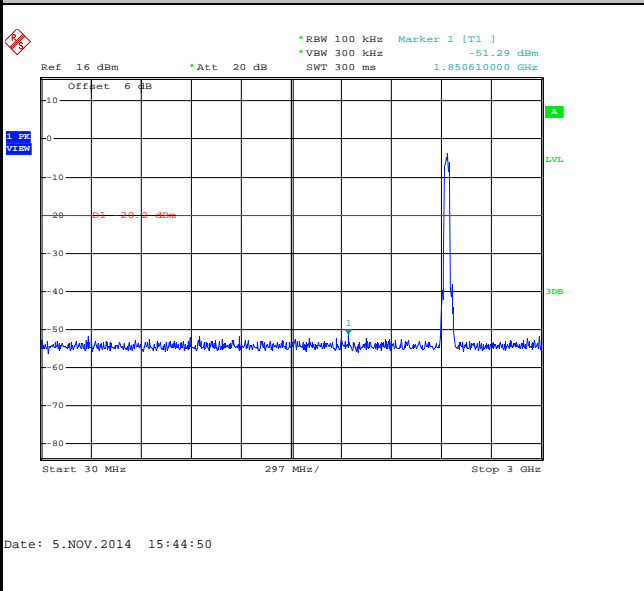

Spurious Emission 2GHz~25GHz

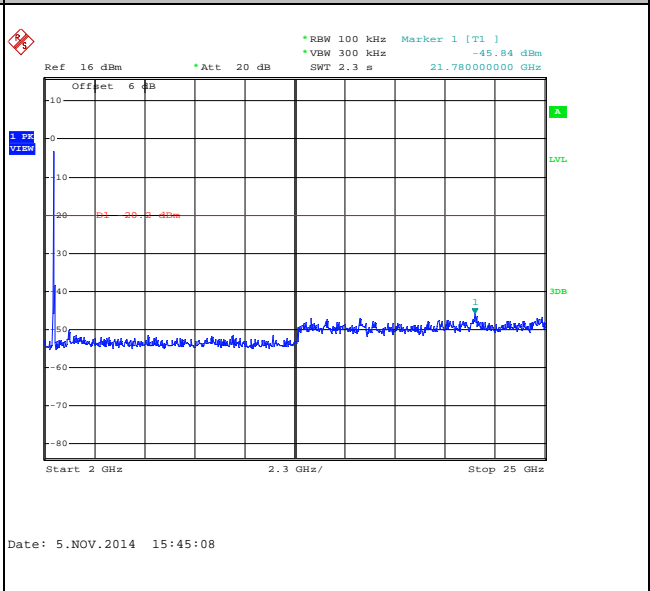



Test Mode :	802.11n HT40	Temperature :	24~25°C
Test Band :	2.4GHz High	Relative Humidity :	49~51%
Test Channel :	09	Test Engineer :	Issac Song

WLAN 802.11n HT40 Channel 09

100kHz PSD reference Level

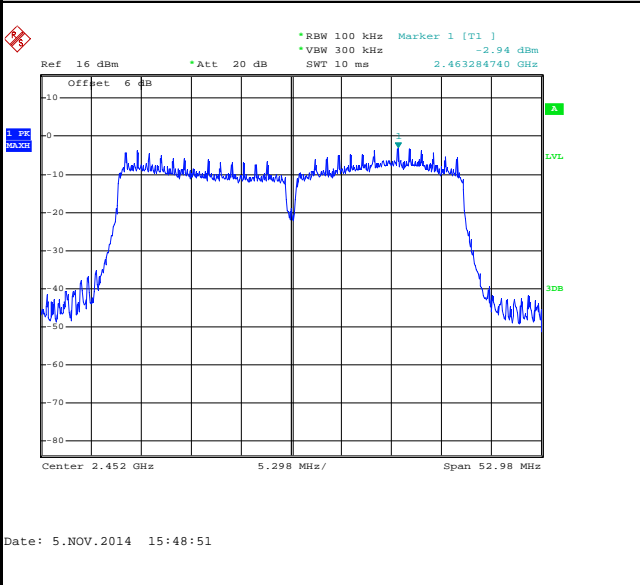

High Channel Plot

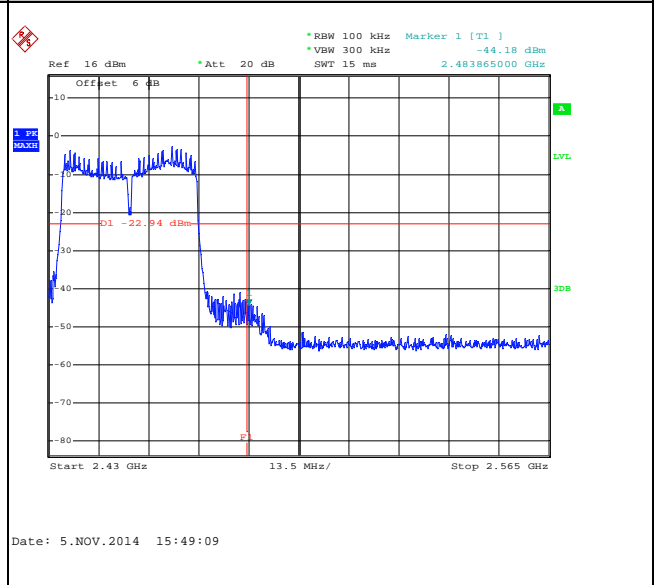

Spurious Emission 30MHz~3GHz

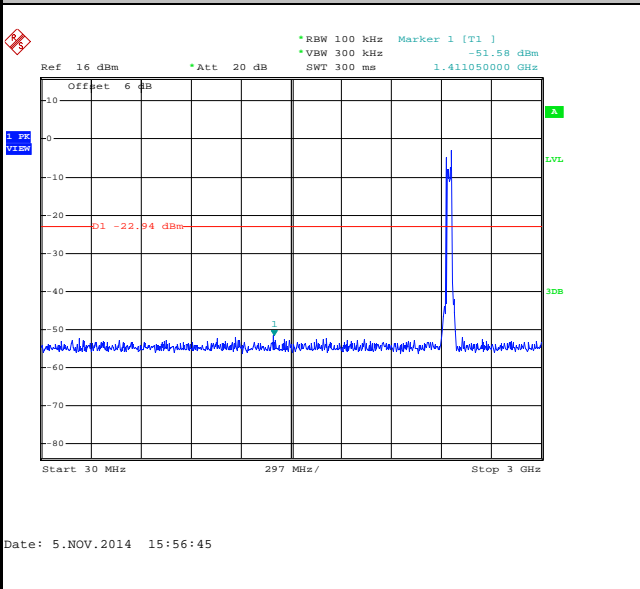

Spurious Emission 2GHz~25GHz

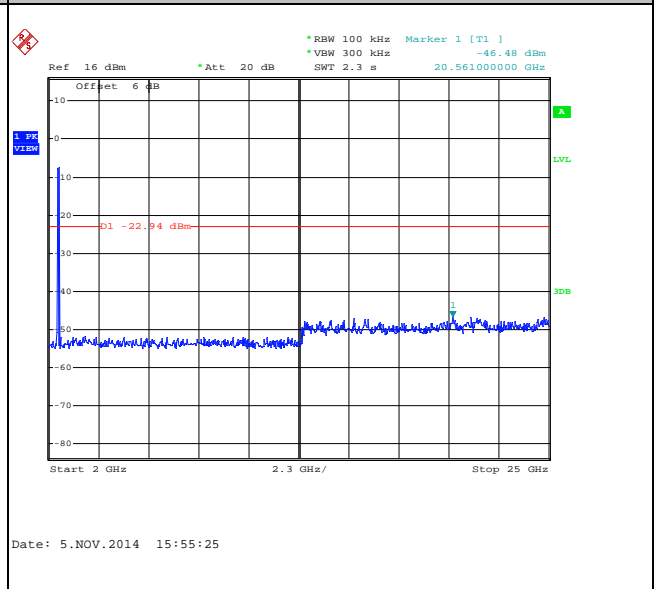



3.5 Radiated Band Edges and Spurious Emission Measurement

3.5.1 Limit of Radiated band edge and Spurious Emission Measurement

In any 100 kHz bandwidth outside the intentional radiator frequency band, all harmonics/spurious must be at least 20 dB below the highest emission level within the authorized band. If the output power of this device was measured by spectrum analyzer, the attenuation under this paragraph shall be 30 dB instead of 20 dB. In addition, radiated emissions which fall in the restricted bands must also comply with the FCC section 15.209 limits as below.

Frequency (MHz)	Field Strength (microvolts/meter)	Measurement Distance (meters)
0.009 – 0.490	2400/F(kHz)	300
0.490 – 1.705	24000/F(kHz)	30
1.705 – 30.0	30	30
30 – 88	100	3
88 – 216	150	3
216 - 960	200	3
Above 960	500	3

3.5.2 Measuring Instruments

The measuring equipment is listed in the section 4 of this test report.



3.5.3 Test Procedures

1. The testing follows FCC KDB Publication No. 558074 D01 DTS Meas. Guidance v03r02.
2. The EUT was arranged to its worst case and then tune the antenna tower (from 1 m to 4 m) and turntable (from 0 degree to 360 degrees) to find the maximum reading. A pre-amp and a high pass filter are used for the test in order to get better signal level.
3. The EUT was placed on a turntable with 0.8 meter above ground.
4. The EUT was set 3 meters from the interference receiving antenna, which was mounted on the top of a variable height antenna tower.
5. Corrected Reading: Antenna Factor + Cable Loss + Read Level - Preamp Factor = Level
6. For measurement below 1GHz, If the emission level of the EUT measured by the peak detector is 3 dB lower than the applicable limit, the peak emission level will be reported. Otherwise, the emission measurement will be repeated using the quasi-peak detector and reported.
7. Use the following spectrum analyzer settings:
 - (1) Span shall wide enough to fully capture the emission being measured;
 - (2) Set RBW=100 kHz for $f < 1$ GHz; $VBW \geq RBW$; Sweep = auto; Detector function = peak; Trace = max hold;
 - (3) Set RBW = 1 MHz, VBW= 3MHz for $f \geq 1$ GHz for peak measurement.

For average measurement:

 - $VBW = 10$ Hz, when duty cycle is no less than 98 percent.
 - $VBW \geq 1/T$, when duty cycle is less than 98 percent where T is the minimum transmission duration over which the transmitter is on and is transmitting at its maximum power control level for the tested mode of operation.

Band	Duty Cycle(%)	T(ms)	1/T(kHz)	VBW Setting
802.11b	98.14	-	-	10Hz
802.11g	88.89	1.39	0.72	1kHz
2.4GHz 802.11n HT20	87.88	1.29	0.77	1kHz
2.4GHz 802.11n HT40	79.19	0.65	1.54	3kHz

3.5.4 Test Setup

For radiated emissions below 30MHz

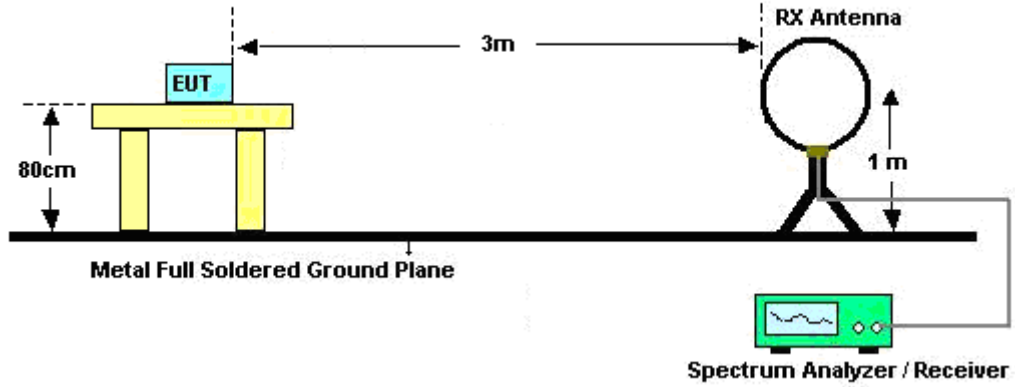

For radiated emissions from 30MHz to 1GHz

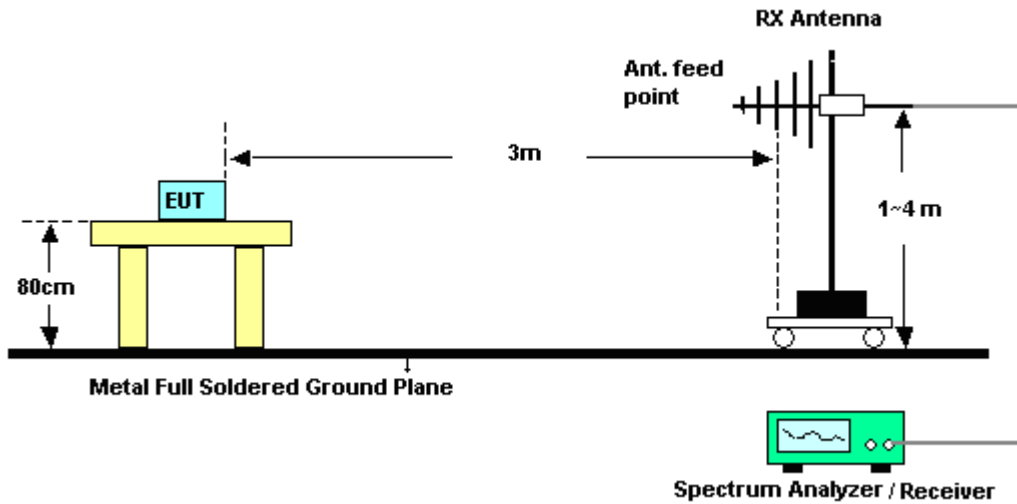

For radiated emissions above 1GHz

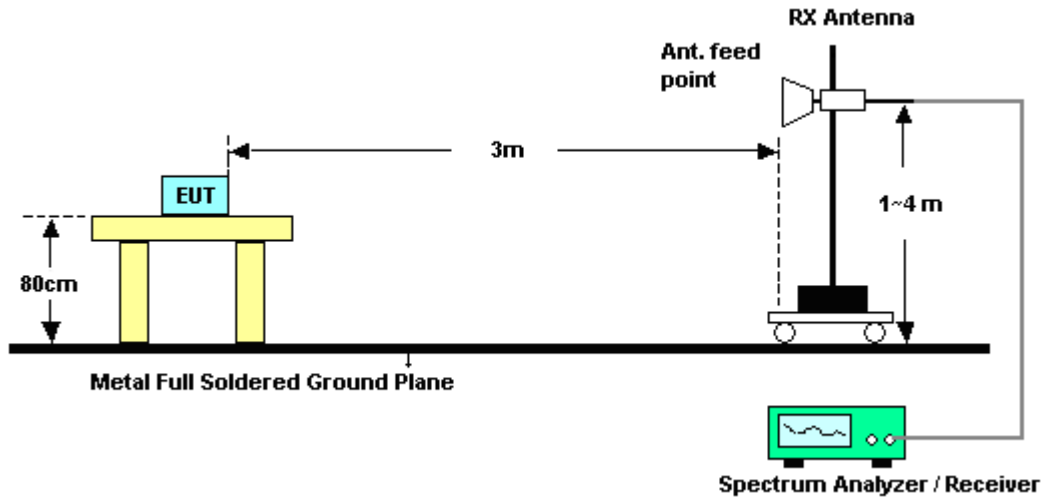

3.5.5 Test Results of Radiated Spurious Emissions (9kHz ~ 30MHz)

The low frequency, which started from 9 kHz to 30MHz, was pre-scanned and the result which was 20dB lower than the limit line per 15.31(o) was not reported.



3.5.6 Test Result of Radiated Spurious at Band Edges

Test Mode :	802.11b	Temperature :	22~23°C
Test Band :	Low	Relative Humidity :	42~43%
Test Channel :	01	Test Engineer :	Simon Lu

ANTENNA POLARITY : HORIZONTAL										
Frequency (MHz)	Level (dBμV/m)	Over Limit (dB)	Limit Line (dBμV/m)	Read Level (dBμV)	Antenna Factor (dB)	Cable Loss (dB)	Preamp Factor (dB)	Ant Pos (cm)	Table Pos (deg)	Remark
2388.12	54.01	-19.99	74	51.91	32.01	6.17	36.08	114	295	Peak
2390	41.49	-12.51	54	39.39	32.01	6.17	36.08	114	295	Average

ANTENNA POLARITY : VERTICAL										
Frequency (MHz)	Level (dBμV/m)	Over Limit (dB)	Limit Line (dBμV/m)	Read Level (dBμV)	Antenna Factor (dB)	Cable Loss (dB)	Preamp Factor (dB)	Ant Pos (cm)	Table Pos (deg)	Remark
2348.88	53.85	-20.15	74	52.25	31.82	6.12	36.34	123	272	Peak
2390	41.09	-12.91	54	38.99	32.01	6.17	36.08	123	272	Average

Test Mode :	802.11b	Temperature :	22~23°C
Test Band :	High	Relative Humidity :	42~43%
Test Channel :	11	Test Engineer :	Simon Lu

ANTENNA POLARITY : HORIZONTAL										
Frequency (MHz)	Level (dBμV/m)	Over Limit (dB)	Limit Line (dBμV/m)	Read Level (dBμV)	Antenna Factor (dB)	Cable Loss (dB)	Preamp Factor (dB)	Ant Pos (cm)	Table Pos (deg)	Remark
2484.58	55.81	-18.19	74	52.93	32.34	6.33	35.79	131	298	Peak
2485.63	42.25	-11.75	54	39.37	32.34	6.33	35.79	131	298	Average

ANTENNA POLARITY : VERTICAL										
Frequency (MHz)	Level (dBμV/m)	Over Limit (dB)	Limit Line (dBμV/m)	Read Level (dBμV)	Antenna Factor (dB)	Cable Loss (dB)	Preamp Factor (dB)	Ant Pos (cm)	Table Pos (deg)	Remark
2484.04	55.07	-18.93	74	52.19	32.34	6.33	35.79	111	265	Peak
2485.75	41.83	-12.17	54	38.95	32.34	6.33	35.79	111	265	Average



Test Mode :	802.11g	Temperature :	22~23°C
Test Band :	Low	Relative Humidity :	42~43%
Test Channel :	01	Test Engineer :	Simon Lu

ANTENNA POLARITY : HORIZONTAL										
Frequency (MHz)	Level (dBμV/m)	Over Limit (dB)	Limit Line (dBμV/m)	Read Level (dBμV)	Antenna Factor (dB)	Cable Loss (dB)	Preamp Factor (dB)	Ant Pos (cm)	Table Pos (deg)	Remark
2390	59.87	-14.13	74	57.77	32.01	6.17	36.08	110	297	Peak
2390	42.03	-11.97	54	39.93	32.01	6.17	36.08	110	297	Average

ANTENNA POLARITY : VERTICAL										
Frequency (MHz)	Level (dBμV/m)	Over Limit (dB)	Limit Line (dBμV/m)	Read Level (dBμV)	Antenna Factor (dB)	Cable Loss (dB)	Preamp Factor (dB)	Ant Pos (cm)	Table Pos (deg)	Remark
2390	58.17	-15.83	74	56.07	32.01	6.17	36.08	118	261	Peak
2390	40.67	-13.33	54	38.57	32.01	6.17	36.08	118	261	Average

Test Mode :	802.11g	Temperature :	22~23°C
Test Band :	High	Relative Humidity :	42~43%
Test Channel :	11	Test Engineer :	Simon Lu

ANTENNA POLARITY : HORIZONTAL										
Frequency (MHz)	Level (dBμV/m)	Over Limit (dB)	Limit Line (dBμV/m)	Read Level (dBμV)	Antenna Factor (dB)	Cable Loss (dB)	Preamp Factor (dB)	Ant Pos (cm)	Table Pos (deg)	Remark
2483.77	59.67	-14.33	74	56.79	32.34	6.33	35.79	131	297	Peak
2483.5	43.04	-10.96	54	40.16	32.34	6.33	35.79	131	297	Average

ANTENNA POLARITY : VERTICAL										
Frequency (MHz)	Level (dBμV/m)	Over Limit (dB)	Limit Line (dBμV/m)	Read Level (dBμV)	Antenna Factor (dB)	Cable Loss (dB)	Preamp Factor (dB)	Ant Pos (cm)	Table Pos (deg)	Remark
2483.86	56.74	-17.26	74	53.86	32.34	6.33	35.79	100	306	Peak
2483.83	40.92	-13.08	54	38.04	32.34	6.33	35.79	100	306	Average



Test Mode :	802.11n HT20	Temperature :	22~23°C
Test Band :	Low	Relative Humidity :	42~43%
Test Channel :	01	Test Engineer :	Simon Lu

ANTENNA POLARITY : HORIZONTAL										
Frequency (MHz)	Level (dBμV/m)	Over Limit (dB)	Limit Line (dBμV/m)	Read Level (dBμV)	Antenna Factor (dB)	Cable Loss (dB)	Preamp Factor (dB)	Ant Pos (cm)	Table Pos (deg)	Remark
2389.92	61.48	-12.52	74	59.38	32.01	6.17	36.08	111	309	Peak
2390	41.75	-12.25	54	39.65	32.01	6.17	36.08	110	308	Average

ANTENNA POLARITY : VERTICAL										
Frequency (MHz)	Level (dBμV/m)	Over Limit (dB)	Limit Line (dBμV/m)	Read Level (dBμV)	Antenna Factor (dB)	Cable Loss (dB)	Preamp Factor (dB)	Ant Pos (cm)	Table Pos (deg)	Remark
2390	59.04	-14.96	74	56.94	32.01	6.17	36.08	100	243	Peak
2390	40.34	-13.66	54	38.24	32.01	6.17	36.08	100	243	Average

Test Mode :	802.11n HT20	Temperature :	22~23°C
Test Band :	High	Relative Humidity :	42~43%
Test Channel :	11	Test Engineer :	Simon Lu

ANTENNA POLARITY : HORIZONTAL										
Frequency (MHz)	Level (dBμV/m)	Over Limit (dB)	Limit Line (dBμV/m)	Read Level (dBμV)	Antenna Factor (dB)	Cable Loss (dB)	Preamp Factor (dB)	Ant Pos (cm)	Table Pos (deg)	Remark
2483.5	59.88	-14.12	74	57	32.34	6.33	35.79	106	296	Peak
2483.53	41.9	-12.1	54	39.02	32.34	6.33	35.79	106	296	Average

ANTENNA POLARITY : VERTICAL										
Frequency (MHz)	Level (dBμV/m)	Over Limit (dB)	Limit Line (dBμV/m)	Read Level (dBμV)	Antenna Factor (dB)	Cable Loss (dB)	Preamp Factor (dB)	Ant Pos (cm)	Table Pos (deg)	Remark
2483.53	56.4	-17.6	74	53.52	32.34	6.33	35.79	123	305	Peak
2483.5	40.25	-13.75	54	37.37	32.34	6.33	35.79	123	305	Average



Test Mode :	802.11n HT40	Temperature :	22~23°C
Test Band :	Low	Relative Humidity :	42~43%
Test Channel :	03	Test Engineer :	Simon Lu

ANTENNA POLARITY : HORIZONTAL										
Frequency (MHz)	Level (dBμV/m)	Over Limit (dB)	Limit Line (dBμV/m)	Read Level (dBμV)	Antenna Factor (dB)	Cable Loss (dB)	Preamp Factor (dB)	Ant Pos (cm)	Table Pos (deg)	Remark
2389.65	56.83	-17.17	74	54.73	32.01	6.17	36.08	137	230	Peak
2390	40.33	-13.67	54	38.23	32.01	6.17	36.08	137	230	Average
2485.72	52.55	-21.45	74	49.67	32.34	6.33	35.79	109	230	Peak
2483.68	40.36	-13.64	54	37.48	32.34	6.33	35.79	109	230	Average

ANTENNA POLARITY : VERTICAL										
Frequency (MHz)	Level (dBμV/m)	Over Limit (dB)	Limit Line (dBμV/m)	Read Level (dBμV)	Antenna Factor (dB)	Cable Loss (dB)	Preamp Factor (dB)	Ant Pos (cm)	Table Pos (deg)	Remark
2390	57.38	-16.62	74	55.28	32.01	6.17	36.08	142	250	Peak
2389.92	39.91	-14.09	54	37.81	32.01	6.17	36.08	142	250	Average
2483.65	52.74	-21.26	74	49.86	32.34	6.33	35.79	138	257	Peak
2483.8	40.48	-13.52	54	37.6	32.34	6.33	35.79	138	257	Average



Test Mode :	802.11n HT40	Temperature :	22~23°C
Test Band :	High	Relative Humidity :	42~43%
Test Channel :	09	Test Engineer :	Simon Lu

ANTENNA POLARITY : HORIZONTAL										
Frequency (MHz)	Level (dBμV/m)	Over Limit (dB)	Limit Line (dBμV/m)	Read Level (dBμV)	Antenna Factor (dB)	Cable Loss (dB)	Preamp Factor (dB)	Ant Pos (cm)	Table Pos (deg)	Remark
2389.65	50.11	-23.89	74	48.01	32.01	6.17	36.08	108	301	Peak
2389.74	39.17	-14.83	54	37.07	32.01	6.17	36.08	108	301	Average
2483.56	69.25	-4.75	74	66.37	32.34	6.33	35.79	104	301	Peak
2483.74	46.93	-7.07	54	44.05	32.34	6.33	35.79	104	301	Average

ANTENNA POLARITY : VERTICAL										
Frequency (MHz)	Level (dBμV/m)	Over Limit (dB)	Limit Line (dBμV/m)	Read Level (dBμV)	Antenna Factor (dB)	Cable Loss (dB)	Preamp Factor (dB)	Ant Pos (cm)	Table Pos (deg)	Remark
2390	50.37	-23.63	74	48.27	32.01	6.17	36.08	100	310	Peak
2390	38.92	-15.08	54	36.82	32.01	6.17	36.08	100	310	Average
2483.53	65.13	-8.87	74	62.25	32.34	6.33	35.79	100	311	Peak
2483.5	43.11	-10.89	54	40.23	32.34	6.33	35.79	100	311	Average



3.5.7 Test Result of Radiated Spurious Emission (30MHz ~ 10th Harmonic)

Note: Pre-scanned all test modes and only choose the worst case mode recorded in the test report for radiated spurious emission below 1GHz.

Test Mode :	802.11b	Temperature :	22~23°C
Test Channel :	01	Relative Humidity :	42~43%
Test Engineer :	Simon Lu	Polarization :	Horizontal
Remark :	1. 2412 MHz is fundamental signal which can be ignored. 2. Average measurement was not performed if peak level went lower than the average limit.		

Frequency (MHz)	Level (dBμV/m)	Over Limit (dB)	Limit Line (dBμV/m)	Read Level (dBμV)	Antenna Factor (dB)	Cable Loss (dB)	Preamp Factor (dB)	Ant Pos (cm)	Table Pos (deg)	Remark
2412	109.47	-	-	107.19	32.08	6.22	36.02	110	313	Peak
2412	102.94	-	-	100.66	32.08	6.22	36.02	110	313	Average
4824	46.42	-27.58	74	40.14	34.2	8.73	36.65	100	321	Peak

Test Mode :	802.11b	Temperature :	22~23°C
Test Channel :	01	Relative Humidity :	42~43%
Test Engineer :	Simon Lu	Polarization :	Vertical
Remark :	1. 2412 MHz is fundamental signal which can be ignored. 2. Average measurement was not performed if peak level went lower than the average limit.		

Frequency (MHz)	Level (dBμV/m)	Over Limit (dB)	Limit Line (dBμV/m)	Read Level (dBμV)	Antenna Factor (dB)	Cable Loss (dB)	Preamp Factor (dB)	Ant Pos (cm)	Table Pos (deg)	Remark
2412	107.47	-	-	105.19	32.08	6.22	36.02	132	282	Peak
2412	100.95	-	-	98.67	32.08	6.22	36.02	132	282	Average
4824	44.79	-29.21	74	38.51	34.2	8.73	36.65	100	145	Peak



Test Mode :	802.11b	Temperature :	22~23°C
Test Channel :	06	Relative Humidity :	42~43%
Test Engineer :	Simon Lu	Polarization :	Horizontal
Remark :	1. 2437 MHz is fundamental signal which can be ignored. 2. Average measurement was not performed if peak level went lower than the average limit.		

Frequency (MHz)	Level (dBμV/m)	Over Limit (dB)	Limit Line (dBμV/m)	Read Level (dBμV)	Antenna Factor (dB)	Cable Loss (dB)	Preamp Factor (dB)	Ant Pos (cm)	Table Pos (deg)	Remark
2437	109.24	-	-	106.72	32.21	6.22	35.91	106	307	Peak
2437	102.64	-	-	100.12	32.21	6.22	35.91	106	307	Average
4874	43.65	-30.35	74	37.53	34.2	8.76	36.84	102	58	Peak
7312	45.06	-28.94	74	37.36	35.72	10.84	38.86	110	34	Peak

Test Mode :	802.11b	Temperature :	22~23°C
Test Channel :	06	Relative Humidity :	42~43%
Test Engineer :	Simon Lu	Polarization :	Vertical
Remark :	1. 2437 MHz is fundamental signal which can be ignored. 2. Average measurement was not performed if peak level went lower than the average limit.		

Frequency (MHz)	Level (dBμV/m)	Over Limit (dB)	Limit Line (dBμV/m)	Read Level (dBμV)	Antenna Factor (dB)	Cable Loss (dB)	Preamp Factor (dB)	Ant Pos (cm)	Table Pos (deg)	Remark
2437	106.83	-	-	104.31	32.21	6.22	35.91	100	297	Peak
2437	100.45	-	-	97.93	32.21	6.22	35.91	100	297	Average
4874	42.61	-31.39	74	36.49	34.2	8.76	36.84	114	78	Peak
7312	47.09	-26.91	74	39.39	35.72	10.84	38.86	123	100	Peak



Test Mode :	802.11b	Temperature :	22~23°C
Test Channel :	11	Relative Humidity :	42~43%
Test Engineer :	Simon Lu	Polarization :	Horizontal
Remark :	1. 2462 MHz is fundamental signal which can be ignored. 2. Average measurement was not performed if peak level went lower than the average limit.		

Frequency (MHz)	Level (dBμV/m)	Over Limit (dB)	Limit Line (dBμV/m)	Read Level (dBμV)	Antenna Factor (dB)	Cable Loss (dB)	Preamp Factor (dB)	Ant Pos (cm)	Table Pos (deg)	Remark
2462	111.1	-	-	108.4	32.27	6.28	35.85	109	305	Peak
2462	104.67	-	-	101.97	32.27	6.28	35.85	109	305	Average
4924	45.46	-28.54	74	39.5	34.2	8.79	37.03	100	25	Peak
7386	46.03	-27.97	74	38.57	35.76	10.89	39.19	110	24	Peak

Test Mode :	802.11b	Temperature :	22~23°C
Test Channel :	11	Relative Humidity :	42~43%
Test Engineer :	Simon Lu	Polarization :	Vertical
Remark :	1. 2462 MHz is fundamental signal which can be ignored. 2. Average measurement was not performed if peak level went lower than the average limit.		

Frequency (MHz)	Level (dBμV/m)	Over Limit (dB)	Limit Line (dBμV/m)	Read Level (dBμV)	Antenna Factor (dB)	Cable Loss (dB)	Preamp Factor (dB)	Ant Pos (cm)	Table Pos (deg)	Remark
2462	106.77	-	-	104.07	32.27	6.28	35.85	120	230	Peak
2462	100.76	-	-	98.06	32.27	6.28	35.85	120	230	Average
4924	43.12	-30.88	74	37.16	34.2	8.79	37.03	100	34	Peak
7386	47.39	-26.61	74	39.93	35.76	10.89	39.19	100	103	Peak



Test Mode :	802.11g	Temperature :	22~23°C
Test Channel :	01	Relative Humidity :	42~43%
Test Engineer :	Simon Lu	Polarization :	Horizontal
Remark :	1. 2412 MHz is fundamental signal which can be ignored. 2. Average measurement was not performed if peak level went lower than the average limit.		

Frequency (MHz)	Level (dBμV/m)	Over Limit (dB)	Limit Line (dBμV/m)	Read Level (dBμV)	Antenna Factor (dB)	Cable Loss (dB)	Preamp Factor (dB)	Ant Pos (cm)	Table Pos (deg)	Remark
2412	106.38	-	-	104.1	32.08	6.22	36.02	107	310	Peak
2412	95.08	-	-	92.8	32.08	6.22	36.02	107	310	Average
4824	45.97	-28.03	74	39.69	34.2	8.73	36.65	169	234	Peak

Test Mode :	802.11g	Temperature :	22~23°C
Test Channel :	01	Relative Humidity :	42~43%
Test Engineer :	Simon Lu	Polarization :	Vertical
Remark :	1. 2412 MHz is fundamental signal which can be ignored. 2. Average measurement was not performed if peak level went lower than the average limit.		

Frequency (MHz)	Level (dBμV/m)	Over Limit (dB)	Limit Line (dBμV/m)	Read Level (dBμV)	Antenna Factor (dB)	Cable Loss (dB)	Preamp Factor (dB)	Ant Pos (cm)	Table Pos (deg)	Remark
2412	105.36	-	-	103.08	32.08	6.22	36.02	120	258	Peak
2412	95.03	-	-	92.75	32.08	6.22	36.02	120	258	Average
4824	46.61	-27.39	74	40.33	34.2	8.73	36.65	159	352	Peak



Test Mode :	802.11g	Temperature :	22~23°C
Test Channel :	06	Relative Humidity :	42~43%
Test Engineer :	Simon Lu	Polarization :	Horizontal
Remark :	1. 2437 MHz is fundamental signal which can be ignored. 2. Average measurement was not performed if peak level went lower than the average limit.		

Frequency (MHz)	Level (dBμV/m)	Over Limit (dB)	Limit Line (dBμV/m)	Read Level (dBμV)	Antenna Factor (dB)	Cable Loss (dB)	Preamp Factor (dB)	Ant Pos (cm)	Table Pos (deg)	Remark
2437	107.45	-	-	104.93	32.21	6.22	35.91	110	293	Peak
2437	97.16	-	-	94.64	32.21	6.22	35.91	110	293	Average
4874	43.61	-30.39	74	37.49	34.2	8.76	36.84	111	45	Peak
7312	42.27	-31.73	74	34.57	35.72	10.84	38.86	100	34	Peak

Test Mode :	802.11g	Temperature :	22~23°C
Test Channel :	06	Relative Humidity :	42~43%
Test Engineer :	Simon Lu	Polarization :	Vertical
Remark :	1. 2437 MHz is fundamental signal which can be ignored. 2. Average measurement was not performed if peak level went lower than the average limit.		

Frequency (MHz)	Level (dBμV/m)	Over Limit (dB)	Limit Line (dBμV/m)	Read Level (dBμV)	Antenna Factor (dB)	Cable Loss (dB)	Preamp Factor (dB)	Ant Pos (cm)	Table Pos (deg)	Remark
2437	106.67	-	-	104.15	32.21	6.22	35.91	100	268	Peak
2437	95.84	-	-	93.32	32.21	6.22	35.91	100	268	Average
4874	43.63	-30.37	74	37.51	34.2	8.76	36.84	103	49	Peak
7312	46.05	-27.95	74	38.35	35.72	10.84	38.86	124	20	Peak



Test Mode :	802.11g	Temperature :	22~23°C
Test Channel :	11	Relative Humidity :	42~43%
Test Engineer :	Simon Lu	Polarization :	Horizontal
Remark :	1. 2462 MHz is fundamental signal which can be ignored. 2. Average measurement was not performed if peak level went lower than the average limit.		

Frequency (MHz)	Level (dBμV/m)	Over Limit (dB)	Limit Line (dBμV/m)	Read Level (dBμV)	Antenna Factor (dB)	Cable Loss (dB)	Preamp Factor (dB)	Ant Pos (cm)	Table Pos (deg)	Remark
2462	108.55	-	-	105.85	32.27	6.28	35.85	109	300	Peak
2462	97.72	-	-	95.02	32.27	6.28	35.85	109	300	Average
4924	46.04	-27.96	74	40.08	34.2	8.79	37.03	105	261	Peak
7386	49.97	-24.03	74	42.51	35.76	10.89	39.19	107	98	Peak

Test Mode :	802.11g	Temperature :	22~23°C
Test Channel :	11	Relative Humidity :	42~43%
Test Engineer :	Simon Lu	Polarization :	Vertical
Remark :	1. 2462 MHz is fundamental signal which can be ignored. 2. Average measurement was not performed if peak level went lower than the average limit.		

Frequency (MHz)	Level (dBμV/m)	Over Limit (dB)	Limit Line (dBμV/m)	Read Level (dBμV)	Antenna Factor (dB)	Cable Loss (dB)	Preamp Factor (dB)	Ant Pos (cm)	Table Pos (deg)	Remark
2462	105.28	-	-	102.58	32.27	6.28	35.85	100	307	Peak
2462	94.01	-	-	91.31	32.27	6.28	35.85	100	307	Average
4924	45.85	-28.15	74	39.89	34.2	8.79	37.03	102	45	Peak
7386	48.78	-25.22	74	41.32	35.76	10.89	39.19	162	305	Peak



Test Mode :	2.4GHz 802.11n HT20	Temperature :	22~23°C
Test Channel :	01	Relative Humidity :	42~43%
Test Engineer :	Simon Lu	Polarization :	Horizontal
Remark :	1. 2412 MHz is fundamental signal which can be ignored. 2. Average measurement was not performed if peak level went lower than the average limit.		

Frequency (MHz)	Level (dBμV/m)	Over Limit (dB)	Limit Line (dBμV/m)	Read Level (dBμV)	Antenna Factor (dB)	Cable Loss (dB)	Preamp Factor (dB)	Ant Pos (cm)	Table Pos (deg)	Remark
2412	105.9	-	-	103.62	32.08	6.22	36.02	110	308	Peak
2412	95.51	-	-	93.23	32.08	6.22	36.02	110	308	Average
4824	46.55	-27.45	74	40.27	34.2	8.73	36.65	115	34	Peak

Test Mode :	2.4GHz 802.11n HT20	Temperature :	22~23°C
Test Channel :	01	Relative Humidity :	42~43%
Test Engineer :	Simon Lu	Polarization :	Vertical
Remark :	1. 2412 MHz is fundamental signal which can be ignored. 2. Average measurement was not performed if peak level went lower than the average limit.		

Frequency (MHz)	Level (dBμV/m)	Over Limit (dB)	Limit Line (dBμV/m)	Read Level (dBμV)	Antenna Factor (dB)	Cable Loss (dB)	Preamp Factor (dB)	Ant Pos (cm)	Table Pos (deg)	Remark
2412	103.9	-	-	101.62	32.08	6.22	36.02	100	243	Peak
2412	92.83	-	-	90.55	32.08	6.22	36.02	100	243	Average
4824	45.98	-28.02	74	39.7	34.2	8.73	36.65	167	88	Peak



Test Mode :	2.4GHz 802.11n HT20	Temperature :	22~23°C
Test Channel :	06	Relative Humidity :	42~43%
Test Engineer :	Simon Lu	Polarization :	Horizontal
Remark :	1. 2437 MHz is fundamental signal which can be ignored. 2. Average measurement was not performed if peak level went lower than the average limit.		

Frequency (MHz)	Level (dBμV/m)	Over Limit (dB)	Limit Line (dBμV/m)	Read Level (dBμV)	Antenna Factor (dB)	Cable Loss (dB)	Preamp Factor (dB)	Ant Pos (cm)	Table Pos (deg)	Remark
2437	106.95	-	-	104.43	32.21	6.22	35.91	110	301	Peak
2437	96.7	-	-	94.18	32.21	6.22	35.91	110	301	Average
4874	45.63	-28.37	74	39.51	34.2	8.76	36.84	105	68	Peak
7312	49.95	-24.05	74	42.25	35.72	10.84	38.86	108	25	Peak

Test Mode :	2.4GHz 802.11n HT20	Temperature :	22~23°C
Test Channel :	06	Relative Humidity :	42~43%
Test Engineer :	Simon Lu	Polarization :	Vertical
Remark :	1. 2437 MHz is fundamental signal which can be ignored. 2. Average measurement was not performed if peak level went lower than the average limit.		

Frequency (MHz)	Level (dBμV/m)	Over Limit (dB)	Limit Line (dBμV/m)	Read Level (dBμV)	Antenna Factor (dB)	Cable Loss (dB)	Preamp Factor (dB)	Ant Pos (cm)	Table Pos (deg)	Remark
2437	105.48	-	-	102.96	32.21	6.22	35.91	122	244	Peak
2437	94.87	-	-	92.35	32.21	6.22	35.91	122	244	Average
4874	46.48	-27.52	74	40.36	34.2	8.76	36.84	167	206	Peak
7312	49.43	-24.57	74	41.73	35.72	10.84	38.86	148	69	Peak



Test Mode :	2.4GHz 802.11n HT20	Temperature :	22~23°C
Test Channel :	11	Relative Humidity :	42~43%
Test Engineer :	Simon Lu	Polarization :	Horizontal
Remark :	1. 2462 MHz is fundamental signal which can be ignored. 2. Average measurement was not performed if peak level went lower than the average limit.		

Frequency (MHz)	Level (dBμV/m)	Over Limit (dB)	Limit Line (dBμV/m)	Read Level (dBμV)	Antenna Factor (dB)	Cable Loss (dB)	Preamp Factor (dB)	Ant Pos (cm)	Table Pos (deg)	Remark
2462	106.96	-	-	104.26	32.27	6.28	35.85	105	297	Peak
2462	96.1	-	-	93.4	32.27	6.28	35.85	105	297	Average
4924	45.94	-28.06	74	39.98	34.2	8.79	37.03	115	98	Peak
7386	49.21	-24.79	74	41.75	35.76	10.89	39.19	105	24	Peak

Test Mode :	2.4GHz 802.11n HT20	Temperature :	22~23°C
Test Channel :	11	Relative Humidity :	42~43%
Test Engineer :	Simon Lu	Polarization :	Vertical
Remark :	1. 2462 MHz is fundamental signal which can be ignored. 2. Average measurement was not performed if peak level went lower than the average limit.		

Frequency (MHz)	Level (dBμV/m)	Over Limit (dB)	Limit Line (dBμV/m)	Read Level (dBμV)	Antenna Factor (dB)	Cable Loss (dB)	Preamp Factor (dB)	Ant Pos (cm)	Table Pos (deg)	Remark
2462	104.53	-	-	101.83	32.27	6.28	35.85	100	305	Peak
2462	93.41	-	-	90.71	32.27	6.28	35.85	100	305	Average
4924	45.52	-28.48	74	39.56	34.2	8.79	37.03	154	69	Peak
7386	49.78	-24.22	74	42.32	35.76	10.89	39.19	108	54	Peak



Test Mode :	2.4GHz 802.11n HT40	Temperature :	22~23°C
Test Channel :	03	Relative Humidity :	42~43%
Test Engineer :	Simon Lu	Polarization :	Horizontal
Remark :	1. 2422 MHz is fundamental signal which can be ignored. 2. Average measurement was not performed if peak level went lower than the average limit.		

Frequency (MHz)	Level (dBμV/m)	Over Limit (dB)	Limit Line (dBμV/m)	Read Level (dBμV)	Antenna Factor (dB)	Cable Loss (dB)	Preamp Factor (dB)	Ant Pos (cm)	Table Pos (deg)	Remark
2422	103.87	-	-	101.47	32.14	6.22	35.96	109	230	Peak
2422	93.06	-	-	90.66	32.14	6.22	35.96	109	230	Average
4844	45.96	-28.04	74	39.75	34.2	8.73	36.72	165	54	Peak
7266	48.76	-25.24	74	40.97	35.71	10.81	38.73	111	254	Peak

Test Mode :	2.4GHz 802.11n HT40	Temperature :	22~23°C
Test Channel :	03	Relative Humidity :	42~43%
Test Engineer :	Simon Lu	Polarization :	Vertical
Remark :	1. 2422 MHz is fundamental signal which can be ignored. 2. Average measurement was not performed if peak level went lower than the average limit.		

Frequency (MHz)	Level (dBμV/m)	Over Limit (dB)	Limit Line (dBμV/m)	Read Level (dBμV)	Antenna Factor (dB)	Cable Loss (dB)	Preamp Factor (dB)	Ant Pos (cm)	Table Pos (deg)	Remark
2422	103.84	-	-	101.44	32.14	6.22	35.96	139	253	Peak
2422	93.55	-	-	91.15	32.14	6.22	35.96	139	253	Average
4844	45.59	-28.41	74	39.38	34.2	8.73	36.72	167	52	Peak
7266	50.32	-23.68	74	42.53	35.71	10.81	38.73	104	59	Peak



Test Mode :	2.4GHz 802.11n HT40	Temperature :	22~23°C
Test Channel :	06	Relative Humidity :	42~43%
Test Engineer :	Simon Lu	Polarization :	Horizontal
Remark :	1. 2437 MHz is fundamental signal which can be ignored. 2. Average measurement was not performed if peak level went lower than the average limit.		

Frequency (MHz)	Level (dBμV/m)	Over Limit (dB)	Limit Line (dBμV/m)	Read Level (dBμV)	Antenna Factor (dB)	Cable Loss (dB)	Preamp Factor (dB)	Ant Pos (cm)	Table Pos (deg)	Remark
2437	105.83	-	-	103.31	32.21	6.22	35.91	109	303	Peak
2437	95.35	-	-	92.83	32.21	6.22	35.91	109	303	Average
4874	46.14	-27.86	74	40.02	34.2	8.76	36.84	168	334	Peak
7312	48.97	-25.03	74	41.27	35.72	10.84	38.86	100	26	Peak

Test Mode :	2.4GHz 802.11n HT40	Temperature :	22~23°C
Test Channel :	06	Relative Humidity :	42~43%
Test Engineer :	Simon Lu	Polarization :	Vertical
Remark :	1. 2437 MHz is fundamental signal which can be ignored. 2. Average measurement was not performed if peak level went lower than the average limit.		

Frequency (MHz)	Level (dBμV/m)	Over Limit (dB)	Limit Line (dBμV/m)	Read Level (dBμV)	Antenna Factor (dB)	Cable Loss (dB)	Preamp Factor (dB)	Ant Pos (cm)	Table Pos (deg)	Remark
2437	102.5	-	-	99.98	32.21	6.22	35.91	100	301	Peak
2437	91.33	-	-	88.81	32.21	6.22	35.91	100	301	Average
4874	45.61	-28.39	74	39.49	34.2	8.76	36.84	102	58	Peak
7312	49.51	-24.49	74	41.81	35.72	10.84	38.86	148	92	Peak



Test Mode :	2.4GHz 802.11n HT40	Temperature :	22~23°C
Test Channel :	09	Relative Humidity :	42~43%
Test Engineer :	Simon Lu	Polarization :	Horizontal
Remark :	1. 2452 MHz is fundamental signal which can be ignored. 2. Average measurement was not performed if peak level went lower than the average limit.		

Frequency (MHz)	Level (dBμV/m)	Over Limit (dB)	Limit Line (dBμV/m)	Read Level (dBμV)	Antenna Factor (dB)	Cable Loss (dB)	Preamp Factor (dB)	Ant Pos (cm)	Table Pos (deg)	Remark
34.85	26.76	-13.24	40	41.85	16.75	0.79	32.63	100	0	Peak
41.64	22.63	-17.37	40	41.18	13.28	0.79	32.62	-	-	Peak
101.78	25.28	-18.22	43.5	45.55	11.32	1.04	32.63	-	-	Peak
149.31	20.31	-23.19	43.5	39.74	11.69	1.44	32.56	-	-	Peak
159.01	20.77	-22.73	43.5	40.52	11.36	1.44	32.55	-	-	Peak
184.23	25.93	-17.57	43.5	46.55	10.4	1.44	32.46	-	-	Peak
2452	106.35	-	-	103.77	32.21	6.28	35.91	108	303	Peak
2452	95.9	-	-	93.32	32.21	6.28	35.91	108	303	Average
4904	45.96	-28.04	74	39.93	34.2	8.79	36.96	116	87	Peak
7356	49.08	-24.92	74	41.54	35.74	10.86	39.06	164	24	Peak



Test Mode :	2.4GHz 802.11n HT40	Temperature :	22~23°C
Test Channel :	09	Relative Humidity :	42~43%
Test Engineer :	Simon Lu	Polarization :	Vertical
Remark :	1. 2452 MHz is fundamental signal which can be ignored. 2. Average measurement was not performed if peak level went lower than the average limit.		

Frequency (MHz)	Level (dBμV/m)	Over Limit (dB)	Limit Line (dBμV/m)	Read Level (dBμV)	Antenna Factor (dB)	Cable Loss (dB)	Preamp Factor (dB)	Ant Pos (cm)	Table Pos (deg)	Remark
33.88	34.34	-5.66	40	48.94	17.24	0.79	32.63	172	346	QP
45.52	30.77	-9.23	40	51.39	11.25	0.79	32.66	-	-	Peak
58.13	25.47	-14.53	40	50.66	6.62	0.79	32.6	-	-	Peak
66.86	21.31	-18.69	40	45.57	7.57	0.79	32.62	-	-	Peak
101.78	20.61	-22.89	43.5	40.88	11.32	1.04	32.63	-	-	Peak
149.31	27.7	-15.8	43.5	47.13	11.69	1.44	32.56	-	-	Peak
2452	102.95	-	-	100.37	32.21	6.28	35.91	100	310	Peak
2452	91.75	-	-	89.17	32.21	6.28	35.91	100	310	Average
4904	45.08	-28.92	74	39.05	34.2	8.79	36.96	114	62	Peak
7356	50.07	-23.93	74	42.53	35.74	10.86	39.06	163	224	Peak

3.6 AC Conducted Emission Measurement

3.6.1 Limit of AC Conducted Emission

For equipment that is designed to be connected to the public utility (AC) power line, the radio frequency voltage that is conducted back onto the AC power line on any frequency or frequencies within the band 150 kHz to 30 MHz shall not exceed the limits in the following table.

Frequency of Emission (MHz)	Conducted Limit (dB μ V)	
	Quasi-Peak	Average
0.15-0.5	66 to 56*	56 to 46*
0.5-5	56	46
5-30	60	50

*Decreases with the logarithm of the frequency.

3.6.2 Measuring Instruments

The measuring equipment is listed in the section 4 of this test report.

3.6.3 Test Procedures

1. The EUT was placed 0.4 meter from the conducting wall of the shielding room, and it was kept at least 80 centimeters from any other grounded conducting surface.
2. Connect EUT to the power mains through a line impedance stabilization network (LISN).
3. All the support units are connecting to the other LISN.
4. The LISN provides 50 ohm coupling impedance for the measuring instrument.
5. The FCC states that a 50 ohm, 50 microhenry LISN should be used.
6. Both sides of AC line were checked for maximum conducted interference.
7. The frequency range from 150 kHz to 30 MHz was searched.
8. Set the test-receiver system to Peak Detect Function and specified bandwidth (IF bandwidth = 9kHz) with Maximum Hold Mode. Then measurement is also conducted by Average Detector and Quasi-Peak Detector Function respectively.

3.6.4 Test Setup

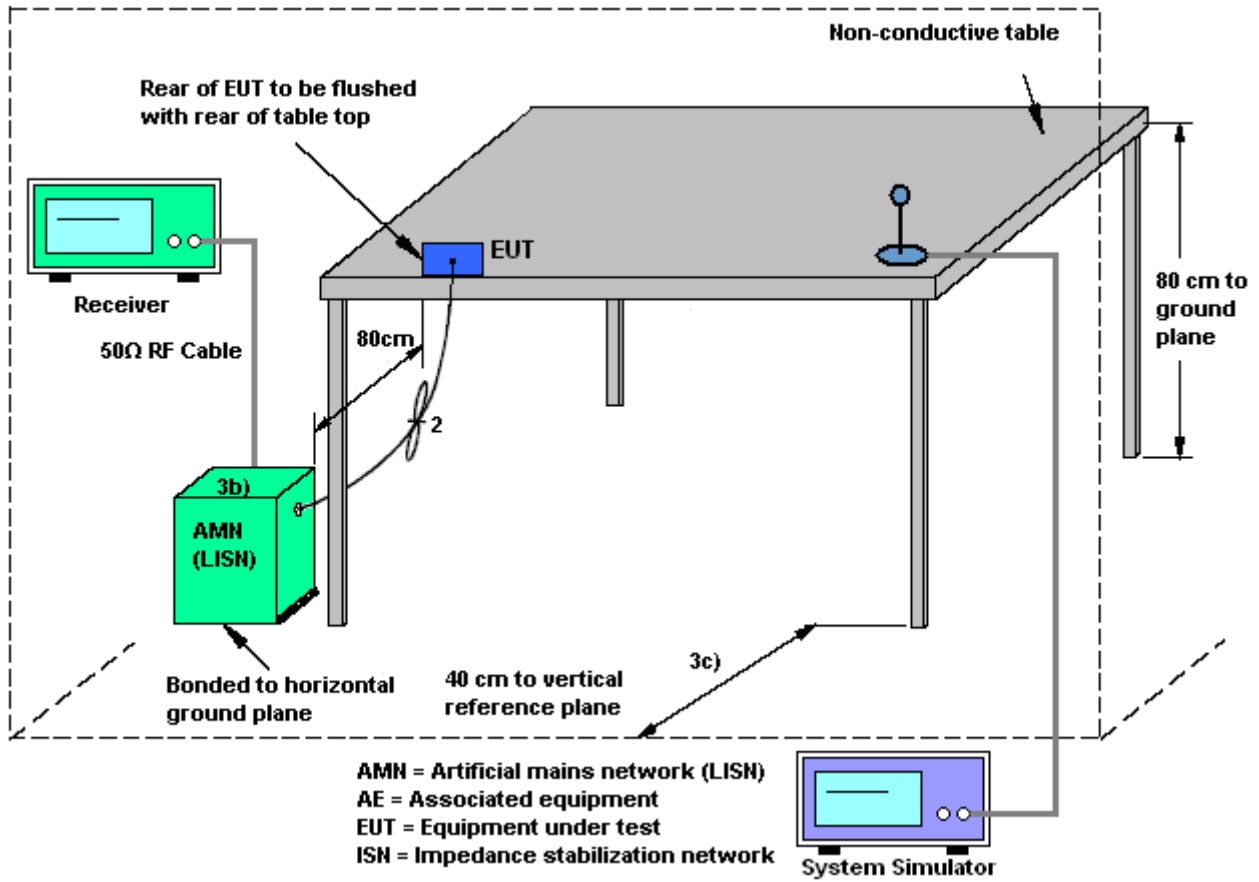



3.6.5 Test Result of AC Conducted Emission

Test Mode :	Mode 1	Temperature :	22~24°C
Test Engineer :	Eligah Wang	Relative Humidity :	38~40%
Test Voltage :	120Vac / 60Hz	Phase :	Line
Function Type :	GSM850 Idle + Bluetooth Link + WLAN Link + USB Cable (Charging from Adapter) + Earphone + SIM1		

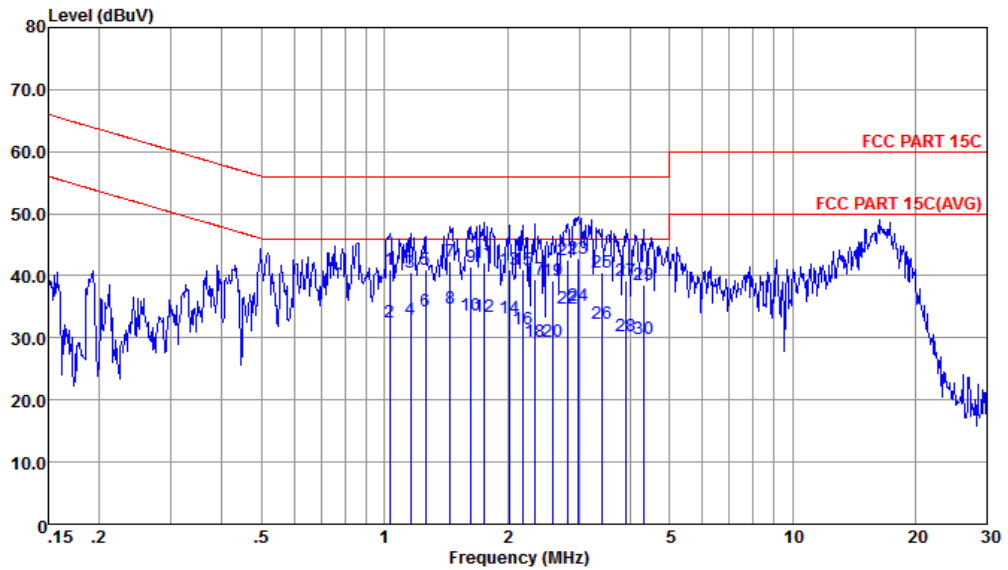

Site : CO01-KS
Condition : FCC PART 15C LISN-L20140306 LINE

mode : Mode 1

	Freq	Level	Over Limit	Limit Line	Read Level	LISN Factor	Cable Loss	Remark
	MHz	dBuV	dB	dBuV	dBuV	dB	dB	
1	1.03	41.05	-14.95	56.00	30.30	0.10	10.65	QP
2	1.03	32.55	-13.45	46.00	21.80	0.10	10.65	Average
3	1.16	40.56	-15.44	56.00	29.80	0.10	10.66	QP
4	1.16	32.96	-13.04	46.00	22.20	0.10	10.66	Average
5	1.26	41.06	-14.94	56.00	30.30	0.10	10.66	QP
6	1.26	34.36	-11.64	46.00	23.60	0.10	10.66	Average
7	1.45	42.28	-13.72	56.00	31.50	0.10	10.68	QP
8	1.45	34.68	-11.32	46.00	23.90	0.10	10.68	Average
9	1.63	41.39	-14.61	56.00	30.60	0.10	10.69	QP
10	1.63	33.69	-12.31	46.00	22.90	0.10	10.69	Average
11	1.75	42.09	-13.91	56.00	31.30	0.10	10.69	QP
12	1.75	33.39	-12.61	46.00	22.60	0.10	10.69	Average
13	2.02	41.00	-15.00	56.00	30.20	0.10	10.70	QP
14	2.02	33.10	-12.90	46.00	22.30	0.10	10.70	Average
15	2.18	41.01	-14.99	56.00	30.20	0.10	10.71	QP
16	2.18	31.41	-14.59	46.00	20.60	0.10	10.71	Average
17	2.33	39.43	-16.57	56.00	28.60	0.11	10.72	QP
18	2.33	29.43	-16.57	46.00	18.60	0.11	10.72	Average
19	2.59	39.16	-16.84	56.00	28.30	0.12	10.74	QP
20	2.59	29.46	-16.54	46.00	18.60	0.12	10.74	Average
21	2.82	42.49	-13.51	56.00	31.59	0.13	10.77	QP
22	2.82	34.79	-11.21	46.00	23.89	0.13	10.77	Average
23	2.99	42.82	-13.18	56.00	31.90	0.14	10.78	QP
24 *	2.99	35.22	-10.78	46.00	24.30	0.14	10.78	Average
25	3.42	40.58	-15.42	56.00	29.60	0.17	10.81	QP
26	3.42	32.28	-13.72	46.00	21.30	0.17	10.81	Average
27	3.92	39.11	-16.89	56.00	28.10	0.18	10.83	QP
28	3.92	30.21	-15.79	46.00	19.20	0.18	10.83	Average
29	4.31	38.63	-17.37	56.00	27.60	0.19	10.84	QP
30	4.31	29.93	-16.07	46.00	18.90	0.19	10.84	Average



Test Mode :	Mode 1	Temperature :	22~24°C
Test Engineer :	Eligah Wang	Relative Humidity :	38~40%
Test Voltage :	120Vac / 60Hz	Phase :	Neutral
Function Type :	GSM850 Idle + Bluetooth Link + WLAN Link + USB Cable (Charging from Adapter) + Earphone + SIM1		

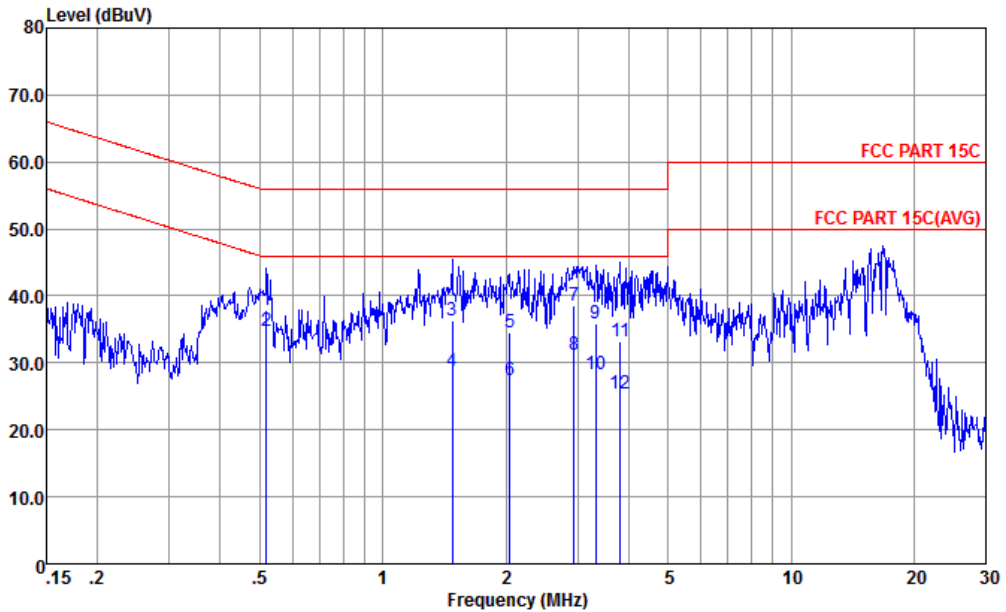

Site : CO01-KS
Condition : FCC PART 15C LISN-N20140306 NEUTRAL

mode : Mode 1

	Freq	Level	Over	Limit	Read	LISN	Cable	Remark
	MHz	dBuV	Limit	Line	Level	Factor	Loss	
			dB	dBuV	dBuV	dB	dB	
1	0.52	37.82	-18.18	56.00	26.90	0.29	10.63	QP
2 *	0.52	34.72	-11.28	46.00	23.80	0.29	10.63	Average
3	1.48	36.38	-19.62	56.00	25.60	0.10	10.68	QP
4	1.48	28.68	-17.32	46.00	17.90	0.10	10.68	Average
5	2.04	34.60	-21.40	56.00	23.80	0.10	10.70	QP
6	2.04	27.40	-18.60	46.00	16.60	0.10	10.70	Average
7	2.95	38.51	-17.49	56.00	27.60	0.13	10.78	QP
8	2.95	31.21	-14.79	46.00	20.30	0.13	10.78	Average
9	3.33	35.87	-20.13	56.00	24.90	0.16	10.81	QP
10	3.33	28.27	-17.73	46.00	17.30	0.16	10.81	Average
11	3.82	33.11	-22.89	56.00	22.10	0.18	10.83	QP
12	3.82	25.31	-20.69	46.00	14.30	0.18	10.83	Average



3.7 Antenna Requirements

3.7.1 Standard Applicable

If directional gain of transmitting antennas is greater than 6dBi, the power shall be reduced by the same level in dB comparing to gain minus 6dBi. For the fixed point-to-point operation, the power shall be reduced by one dB for every 3 dB that the directional gain of the antenna exceeds 6 dBi. The use of a permanently attached antenna or of an antenna that uses a unique coupling to the intentional radiator shall be considered sufficient to comply with the FCC rule.

3.7.2 Antenna Anti-Replacement Construction

An embedded-in antenna design is used.

3.7.3 Antenna Gain

The antenna peak gain of EUT is less than 6 dBi. Therefore, it is not necessary to reduce maximum peak output power limit.



4 List of Measuring Equipment

Instrument	Manufacturer	Model No.	Serial No.	Characteristics	Calibration Date	Test Date	Due Date	Remark
Spectrum Analyzer	R&S	FSP40	100319	9kHz~40GHz	Oct. 28, 2014	Nov. 05, 2014	Oct. 27, 2015	Conducted (TH01-KS)
Pulse Power Sensor	Anritsu	MA2411B	0917070	30MHz~40GHz	Feb. 27, 2014	Nov. 05, 2014	Feb. 26, 2015	Conducted (TH01-KS)
Power Meter	Anritsu	ML2495A	1005002	50MHz Bandwidth	Feb. 27, 2014	Nov. 05, 2014	Feb. 26, 2015	Conducted (TH01-KS)
EMI Test Receiver	R&S	ESCI	100534	9kHz~3GHz	Oct. 25, 2014	Nov. 08, 2014	Oct. 24, 2015	Radiation (03CH01-KS)
Spectrum Analyzer	R&S	FSP30	101399	9kHz~30GHz	May 04, 2014	Nov. 08, 2014	May 03, 2015	Radiation (03CH01-KS)
Loop Antenna	R&S	HFH2-Z2	100321	9kHz~30MHz	Nov. 13, 2013	Nov. 08, 2014	Nov. 12, 2014	Radiation (03CH01-KS)
Bilog Antenna	SCHAFFNER	CBL6112D	23182	25MHz~2GHz	Jan. 08, 2014	Nov. 08, 2014	Jan. 07, 2015	Radiation (03CH01-KS)
Double Ridge Horn Antenna	ETS-Lindgren	3117	75957	1GHz~18GHz	Nov. 08, 2014	Nov. 08, 2014	Nov. 07, 2015	Radiation (03CH01-KS)
Active Horn Antenna	com-power	AHA-118	701030	1GHz~18GHz	Nov. 08, 2014	Nov. 08, 2014	Nov. 07, 2015	Radiation (03CH01-KS)
SHF-EHF Horn	Schwarzbeck	BBHA 9170	BBHA170249	15GHz~40GHz	Mar. 10, 2014	Nov. 08, 2014	Mar. 09, 2015	Radiation (03CH01-KS)
Amplifier	com-power	PA-103A	161073	1MHz~1GHz	May 04, 2014	Nov. 08, 2014	May 03, 2015	Radiation (03CH01-KS)
Amplifier	Agilent	8449B	3008A02371	1GHz~26.5GHz	Oct. 28, 2014	Nov. 08, 2014	Oct. 27, 2015	Radiation (03CH01-KS)
AC Power Source	Chroma	61601	F104090004	N/A	NCR	Nov. 08, 2014	NCR	Radiation (03CH01-KS)
Turn Table	MF	MF7802	N/A	0~360 degree	NCR	Nov. 08, 2014	NCR	Radiation (03CH01-KS)
Antenna Mast	MF	MF7802	N/A	1 m~4 m	NCR	Nov. 08, 2014	NCR	Radiation (03CH01-KS)
EMI Receiver	R&S	ESCI7	100768	9kHz~7GHz;	May 04, 2014	Nov. 10, 2014	May 03, 2015	Conduction (CO01-KS)
AC LISN	MessTec	AN3016	060103	9kHz~30MHz	Oct. 25, 2014	Nov. 10, 2014	Oct. 24, 2015	Conduction (CO01-KS)
AC LISN (for auxiliary equipment)	MessTec	AN3016	060105	9kHz~30MHz	Oct. 25, 2014	Nov. 10, 2014	Oct. 24, 2015	Conduction (CO01-KS)
AC Power Source	Chroma	61602	ABP00000811	AC 0V~300V, 45Hz~1000Hz	Oct. 25, 2014	Nov. 10, 2014	Oct. 24, 2015	Conduction (CO01-KS)



5 Uncertainty of Evaluation

Uncertainty of Conducted Emission Measurement (150kHz ~ 30MHz)

Measuring Uncertainty for a Level of Confidence of 95% ($U = 2Uc(y)$)	2.3dB
---	-------

Uncertainty of Radiated Emission Measurement (30 MHz ~ 1000 MHz)

Measuring Uncertainty for a Level of Confidence of 95% ($U = 2Uc(y)$)	2.5dB
---	-------