

**FCC 47 CFR PART 15 SUBPART E &
INDUSTRY CANADA RSS-247**

TEST REPORT

For

Tablet Computer

Model: A6002

Trade Name: acer

Issued to

Acer Incorporated

8F, 88, Sec 1, Xintai 5th Rd. Xizhi, New Taipei City 221 Taiwan, R.O.C

Issued by

Compliance Certification Services Inc.

**No.11, Wugong 6th Rd., Wugu Dist.,
New Taipei City 24891, Taiwan. (R.O.C.)**

<http://www.ccsrf.com>

service@ccsrf.com

Issued Date: April 20, 2016



**Testing Laboratory
1309**

Note: This report shall not be reproduced except in full, without the written approval of Compliance Certification Services Inc. This document may be altered or revised by Compliance Certification Services Inc. personnel only, and shall be noted in the revision section of the document.

Revision History

Rev.	Issue Date	Revisions	Effect Page	Revised By
00	April 20, 2016	Initial Issue	ALL	Doris Chu

TABLE OF CONTENTS

1. TEST RESULT CERTIFICATION	4
2. EUT DESCRIPTION.....	5
3. TEST METHODOLOGY.....	6
3.1 EUT CONFIGURATION	6
3.2 EUT EXERCISE	6
3.3 GENERAL TEST PROCEDURES	6
3.4 FCC PART 15.205 RESTRICTED BANDS OF OPERATIONS.....	7
3.5 DESCRIPTION OF TEST MODES	8
4. INSTRUMENT CALIBRATION	9
4.1 MEASURING INSTRUMENT CALIBRATION.....	9
4.2 MEASUREMENT EQUIPMENT USED.....	9
4.3 MEASUREMENT UNCERTAINTY	10
5 FACILITIES AND ACCREDITATIONS	11
5.1 FACILITIES	11
5.2 LABORATORY ACCREDITATIONS AND LISTING	11
5.3 TABLE OF ACCREDITATIONS AND LISTINGS	12
6 SETUP OF EQUIPMENT UNDER TEST	13
6.1 SETUP CONFIGURATION OF EUT.....	13
6.2 SUPPORT EQUIPMENT	13
7 RSS-247 REQUIREMENTS.....	14
7.1 99%BANDWIDTH.....	14
7.2 6DB BANDWIDTH	21
7.3 MAXIMUM CONDUCTED OUTPUT POWER	28
7.4 BAND EDGES MEASUREMENT	30
7.5 PEAK POWER SPECTRAL DENSITY	48
7.6 RADIATED EMISSIONS.....	55
7.7 POWERLINE CONDUCTED EMISSIONS	77
APPENDIX I PHOTOGRAPHS OF TEST SETUP.....	80

1. TEST RESULT CERTIFICATION

Applicant: Acer Incorporated
8F, 88, Sec 1, Xintai 5th Rd. Xizhi, New Taipei City 221
Taiwan, R.O.C

Manufacturer: Acer Incorporated
8F, 88, Sec 1, Xintai 5th Rd. Xizhi, New Taipei City 221
Taiwan, R.O.C

Equipment Under Test: Tablet Computer

Model Number: A6002

Trade Name: acer

Date of Test: April 1 ~ 14, 2016

APPLICABLE STANDARDS	
STANDARD	TEST RESULT
FCC 47 CFR Part 15 Subpart E & Industry Canada RSS-247 Issue 1	No non-compliance noted

We hereby certify that:

Compliance Certification Services Inc. tested the above equipment in accordance with the requirements set forth in the above standards. The test results show that the equipment tested is capable of demonstrating compliance with the requirements as documented in this report.

The test results of this report relate only to the tested sample identified in this report.

Approved by

Reviewed by



Miller Lee
Manager
Compliance Certification Services Inc.

Angel Cheng
Section Manager
Compliance Certification Services Inc.

2. EUT DESCRIPTION

Product	Tablet Computer
Model Number	A6002
Trade Name	acer
Power Supply	1.VDC from Power Adapter 2. Power from Battery 3. Powered from host device via USB
Received Date	March 29, 2016
Frequency Range	IEEE 802.11a/ IEEE 802.11n HT 20 MHz: 5745~5825 MHz IEEE 802.11n HT 40 MHz: 5755~5795 MHz
Transmit Power	IEEE 802.11a mode: 13.14dBm IEEE 802.11n HT 20 MHz mode: 13.20dBm IEEE 802.11n HT 40 MHz mode: 13.48dBm
Number of Channels	IEEE 802.11a mode: 5 Channels IEEE 802.11n HT 20 MHz mode: 5 Channels IEEE 802.11n HT 40 MHz mode: 2 Channels
Antenna Specification	Model: A10H FPC Antenna / Gain: 3.9dBi

Remark: 1. The sample selected for test was engineering sample that approximated to production product and was provided by manufacturer.

2. Keypast List :

Components	Vendor	Model Name or Key Spec.	
EMMC(FLASH)	Hynix	H26M52103FMR	16G
	Sandisk	SDIN9DS2	32G
CPU	MTK	MT8163V/A	64-bit Quad Cortex A53
DDR3L	Hynix	H5TC4G83CFR-PBA	2GB (512*8*4)
M/B	Sun & lynn	A10H_V1.1	94V-0
LCD Panel	Kingdisplay	KD101N51-34NP-A1 19	-
Battery	TCL	D279594NR01 (1S2P)	3.7V
Front Camera module	microkore	W05P4021 V2	GC2355
Rear Camera module	microkore	W05P4021 V2	OV5670
Speaker left	Haosheng	XHS160911WW30P30-02-RH	4Ω
Speaker right	Haosheng	XHS160911WW30P30-06-RH	4Ω
Adapter	Liteon	PA-1100-25 Rating: Input: 100~240V, 50/60Hz , 0.3A Output: 5.2V, 2A	
	Delta	ADP-10HW A Rating: Input: 100~240V, 50/60Hz , 0.4A Output: 5.35V, 2A	

3. TEST METHODOLOGY

The tests documented in this report were performed in accordance with ANSI C63.10: 2013 and FCC CFR 47 Part 15.207, 15.209, 15.407 and KDB 789033 D02 General UNII Test Procedures New Rules v01r01.

The tests documented in this report were performed in accordance with IC RSS-247, IC RSS-Gen and ANSI C63.10:2013.

This submittal(s) (test report) is intended for IC Certification with Industry Canada RSS-247.

3.1 EUT CONFIGURATION

The EUT configuration for testing is installed for RF field strength measurement to meet the Commissions requirement, and is operated in a manner intended to generate the maximum emission in a continuous normal application.

3.2 EUT EXERCISE

The EUT is operated in the engineering mode to fix the Tx frequency for the purposes of measurement.

According to its specifications, the EUT must comply with the requirements of Section 15.407 under the FCC Rules Part 15 Subpart E.

3.3 GENERAL TEST PROCEDURES

Conducted Emissions

According to the requirements in ANSI C63.10: 2013, the conducted emission from the EUT is measured in the frequency range between 0.15 MHz and 30MHz, using the CISPR Quasi-Peak detector mode.

Radiated Emissions

The EUT is placed on the turntable, which is 1.5 m above the ground plane. The turntable is then rotated for 360 degrees to determine the proper orientation for the maximum emission level. The EUT is set 3m away from the receiving antenna, which is varied from 1m to 4m to find out the highest emission level. And, each emission is to be maximized by changing the horizontal and vertical polarization of the receiving antenna. In order to find out the maximum emissions, exploratory radiated emission measurements were made according to the requirements in ANSI C63.10: 2013.

3.4 FCC PART 15.205 RESTRICTED BANDS OF OPERATIONS

(a) Except as shown in paragraph (d) of this section, only spurious emissions are permitted in any of the frequency bands listed below:

MHz	MHz	MHz	GHz
0.090 - 0.110	16.42 - 16.423	399.9 - 410	4.5 - 5.15
¹ 0.495 - 0.505	16.69475 - 16.69525	608 - 614	5.35 - 5.46
2.1735 - 2.1905	16.80425 - 16.80475	960 - 1240	7.25 - 7.75
4.125 - 4.128	25.5 - 25.67	1300 - 1427	8.025 - 8.5
4.17725 - 4.17775	37.5 - 38.25	1435 - 1626.5	9.0 - 9.2
4.20725 - 4.20775	73 - 74.6	1645.5 - 1646.5	9.3 - 9.5
6.215 - 6.218	74.8 - 75.2	1660 - 1710	10.6 - 12.7
6.26775 - 6.26825	108 - 121.94	1718.8 - 1722.2	13.25 - 13.4
6.31175 - 6.31225	123 - 138	2200 - 2300	14.47 - 14.5
8.291 - 8.294	149.9 - 150.05	2310 - 2390	15.35 - 16.2
8.362 - 8.366	156.52475 -	2483.5 - 2500	17.7 - 21.4
8.37625 - 8.38675	156.52525	2655 - 2900	22.01 - 23.12
8.41425 - 8.41475	156.7 - 156.9	3260 - 3267	23.6 - 24.0
12.29 - 12.293	162.0125 - 167.17	3332 - 3339	31.2 - 31.8
12.51975 - 12.52025	167.72 - 173.2	3345.8 - 3358	36.43 - 36.5
12.57675 - 12.57725	240 - 285	3600 - 4400	(²)
13.36 - 13.41	322 - 335.4		

¹ Until February 1, 1999, this restricted band shall be 0.490-0.510 MHz.

² Above 38.6

(b) Except as provided in paragraphs (d) and (e), the field strength of emissions appearing within these frequency bands shall not exceed the limits shown in Section 15.209. At frequencies equal to or less than 1000 MHz, compliance with the limits in Section 15.209 shall be demonstrated using measurement instrumentation employing a CISPR quasi-peak detector. Above 1000 MHz, compliance with the emission limits in Section 15.209 shall be demonstrated based on the average value of the measured emissions. The provisions in Section 15.35 apply to these measurements.

3.5 DESCRIPTION OF TEST MODES

The EUT (model: A6002) comes with two types of power adapter (model: PA-1100-25 / ADP-10HW A) for sale. After the preliminary test, the power adapter ADP-10HW A was found to emit the worst emissions and therefore had been tested under operating condition.

Software used to control the EUT for staying in continuous transmitting and receiving mode was programmed.

After verification, all tests were carried out with the worst case test modes as shown below except radiated spurious emission below 1GHz, which worst case was in normal link mode only.

IEEE 802.11a mode / 5745 ~ 5825MHz

Channel Low (5745MHz), Channel Mid (5785MHz) and Channel High (5825MHz) with 6Mbps data rate were chosen for full testing.

IEEE 802.11n HT 20 MHz mode / 5745 ~ 5825MHz

Channel Low(5745MHz), Channel Mid(5785MHz) and Channel High(5825MHz) with 6.5Mbps data rate were chosen for full testing.

IEEE 802.11n HT 40 MHz mode / 5755 ~ 5795MHz

Channel Low(5755MHz) and Channel High(5795MHz) with 13.5Mbps data rate were chosen for full testing.

For Conducted & Conduction & Radiated above 1GHz

The field strength of spurious emission was measured in the following position: EUT stand-up position (Z axis), lie-down position (X, Y axis). The worst emission was found in lie-down position (X axis) and the worst case was recorded.

For Radiated below 1GHz

The field strength of spurious emission was measured in the following position: EUT stand-up position (Z axis), lie-down position (X, Y axis). The worst emission was found in lie-down position (Y axis) and the worst case was recorded.

4. INSTRUMENT CALIBRATION

4.1 MEASURING INSTRUMENT CALIBRATION

The measuring equipment, which was utilized in performing the tests documented herein, has been calibrated in accordance with the manufacturer's recommendations for utilizing calibration equipment, which is traceable to recognized national standards.

4.2 MEASUREMENT EQUIPMENT USED

Equipment Used for Emissions Measurement

Remark: Each piece of equipment is scheduled for calibration once a year and Loop Antenna is scheduled for calibration once three years.

Conducted Emissions Test Site					
Name of Equipment	Manufacturer	Model	Serial Number	Calibration Date	Calibration Due
DC Power Supplies	GW Instek	SPS-3610	GPE880163	01/19/2016	01/18/2017
Power Meter	Anritsu	ML2495A	1012009	07/08/2015	07/07/2016
Power Sensor	Anritsu	MA2411B	917072	07/08/2015	07/07/2016
Signal Analyzer	R&S	FSV 40	101073	07/20/2015	07/19/2016
Spectrum Analyzer	Agilent	E4446A	US42510268	02/15/2016	02/14/2017
Thermostatic/Hrgrosatic Chamber	TAICHY	MHG-150LF	930619	10/08/2015	10/07/2016
Vector Signal Generator	R&S	SMU 200A	102239	03/10/2016	03/09/2017
AC Power Source	EXTECH	6205	1140845	N.C.R	N.C.R

Wugu 966 Chamber A					
Name of Equipment	Manufacturer	Model	Serial Number	Calibration Date	Calibration Due
Bilog Antenna	Sunol Sciences	JB3	A030105	08/06/2015	08/05/2016
EMI Test Receiver	R&S	ESCI	100064	06/04/2015	06/03/2016
Horn Antenna	EMCO	3117	55165	02/24/2016	02/23/2017
Horn Antenna	EMCO	3116	26370	01/15/2016	01/14/2017
K Type Cable	Huber+Suhner	SUCOFLEX 102	29406/2	01/12/2016	01/11/2017
K Type Cable	Huber+Suhner	SUCOFLEX 102	22470/2	01/12/2016	01/11/2017
Pre-Amplifier	MITEQ	AMF-6F-260400-40-8P	985646	01/14/2016	01/13/2017
Pre-Amplifier	EMCI	EMC 012635	980151	06/05/2015	06/04/2016
Pre-Amplifier	EMCI	EM330	N/A	06/05/2015	06/04/2016
Spectrum Analyzer	Agilent	E4446A	US42510252	12/08/2015	12/07/2016
Antenna Tower	CCS	CC-A-1F	N/A	N.C.R	N.C.R
Controller	CCS	CC-C-1F	N/A	N.C.R	N.C.R
Turn Table	CCS	CC-T-1F	N/A	N.C.R	N.C.R
Software	EZ-EMC (CCS-3A1RE)				

Conducted Emission Room # B					
Name of Equipment	Manufacturer	Model	Serial Number	Calibration Date	Calibration Due
EMI Test Receiver	R&S	ESCI	101073	09/09/2015	09/08/2016
LISN	SCHWARZBECK	NSLK 8127	8127-541	11/23/2015	11/22/2016
LISN	R&S	ENV216	101054	05/07/2015	05/06/2016
Capacitive Voltage Probe	FCC	F-CVP-1	100185	03/09/2016	03/08/2017
Test S/W	CCS-3A1-CE				

4.3 MEASUREMENT UNCERTAINTY

PARAMETER	UNCERTAINTY
Powerline Conducted Emission	+/- 1.2575
3M Semi Anechoic Chamber / 30M~200M	+/- 4.0138
3M Semi Anechoic Chamber / 200M~1000M	+/- 3.9483
3M Semi Anechoic Chamber / 1G~8G	+/- 2.5975
3M Semi Anechoic Chamber / 8G~18G	+/- 2.6112
3M Semi Anechoic Chamber / 18G~26G	+/- 2.7389
3M Semi Anechoic Chamber / 26G~40G	+/- 2.9683

Remark: This uncertainty represents an expanded uncertainty expressed at approximately the 95% confidence level using a coverage factor of $k=2$.

5 FACILITIES AND ACCREDITATIONS

5.1 FACILITIES

All measurement facilities used to collect the measurement data are located at

- No.199, Chunghsen Road, Hsintien City, Taipei Hsien, Taiwan, R.O.C.
Tel: 886-2-2217-0894 / Fax: 886-2-2217-1029
- No.11, Wugong 6th Rd., Wugu Dist., New Taipei City 248, Taiwan (R.O.C.)
Tel: 886-2-2299-9720 / Fax: 886-2-2298-4045
- No.81-1, Lane 210, Bade 2nd Rd., Lujhu Township, Taoyuan County 33841, TAIWAN, R.O.C.
Tel: 886-3-324-0332 / Fax: 886-3-324-5235



The sites are constructed in conformance with the requirements of ANSI C63.7, ANSI C63.10: 2013 and CISPR Publication 22.

All receiving equipment conforms to CISPR Publication 16-1, "Radio Interference Measuring Apparatus and Measurement Methods."

5.2 LABORATORY ACCREDITATIONS AND LISTING

The test facilities used to perform radiated and conducted emissions tests are accredited by American Association for Laboratory Accreditation Program for the specific scope accreditation under Lab Code: 0824-01 to perform Electromagnetic Interference tests according to FCC Part 15 and CISPR 22 requirements. In addition, the test facilities are listed with Industry Canada, Certification and Engineering Bureau, IC 2324G-1 for 3M Semi Anechoic Chamber A, IC 2324G-2 for 3M Semi Anechoic Chamber B.

5.3 TABLE OF ACCREDITATIONS AND LISTINGS

Country	Agency	Scope of Accreditation	Logo
USA	FCC	3M Semi Anechoic Chamber (FCC MRA: TW1039) to perform FCC Part 15 measurements	 FCC MRA: TW1039
Taiwan	TAF	LP0002, RTTE01, FCC Method-47 CFR Part 15 Subpart C, D, E, RSS-247, RSS-310 IDA TS SRD, AS/NZS 4268, AS/NZS 4771, TS 12.1 & 12.2, ETSI EN 300 440-1, ETSI EN 300 440-2, ETSI EN 300 328, ETSI EN 300 220-1, ETSI EN 300 220-2, ETSI EN 301 893, ETSI EN 301 489-1/3/7/17 FCC OET Bulletin 65 + Supplement C, EN 50360, EN 50361, EN 50371, RSS 102, EN 50383, EN 50385, EN 50392, IEC 62209, CNS 14958-1, CNS 14959 FCC Method -47 CFR Part 15 Subpart B IEC / EN 61000-3-2, IEC / EN 61000-3-3, IEC / EN 61000-4-2/3/4/5/6/8/11	
Canada	Industry Canada	3M Semi Anechoic Chamber (IC 2324G-1 / IC 2324G-2) to perform	

* No part of this report may be used to claim or imply product endorsement by A2LA or any agency of the US Government.

6 SETUP OF EQUIPMENT UNDER TEST

6.1 SETUP CONFIGURATION OF EUT

See test photographs attached in Appendix I for the actual connections between EUT and support equipment.

6.2 SUPPORT EQUIPMENT

No.	Device Type	Brand	Model	Series No.	FCC ID	Data Cable	Power Cord
	N/A						

Remark:

1. *All the equipment/cables were placed in the worst-case configuration to maximize the emission during the test.*
2. *Grounding was established in accordance with the manufacturer's requirements and conditions for the intended use.*

7 RSS-247 REQUIREMENTS

7.1 99%BANDWIDTH

Test Configuration

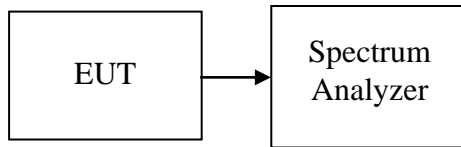

TEST PROCEDURE

The resolution bandwidth shall be set to as close to 1% of the selected span as is possible without being below 1%. The video bandwidth shall be set to 3 times the resolution bandwidth. Video averaging is not permitted. Where practical, a sampling detector shall be used since a peak or, peak hold.

TEST RESULTS

No non-compliance noted.

Test Data**Test mode: IEEE 802.11a mode / 5745 ~ 5825MHz**

Channel	Frequency (MHz)	99%Bandwidth (MHz)
Low	5745	16.7788
Mid	5785	16.9230
High	5825	16.9230

Test mode: IEEE 802.11n HT 20 MHz mode / 5745 ~ 5825MHz

Channel	Frequency (MHz)	99% Bandwidth (MHz)
Low	5745	17.6923
Mid	5785	17.7403
High	5825	17.6923

Test mode: IEEE 802.11n HT 40 MHz mode / 5755 ~ 5815MHz

Channel	Frequency (MHz)	99% Bandwidth (MHz)
Low	5755	36.4102
High	5795	36.4102

Test Plot

IEEE 802.11a mode / 5745 ~ 5825MHz

99% Bandwidth (CH Low)

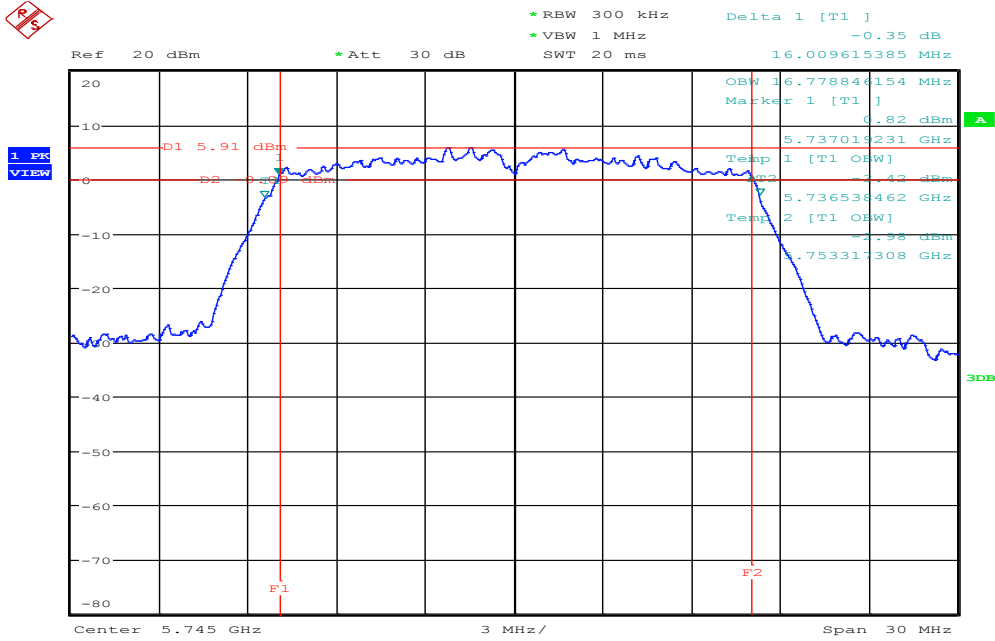

Date: 1.APR.2016 20:11:02

99% Bandwidth (CH Mid)

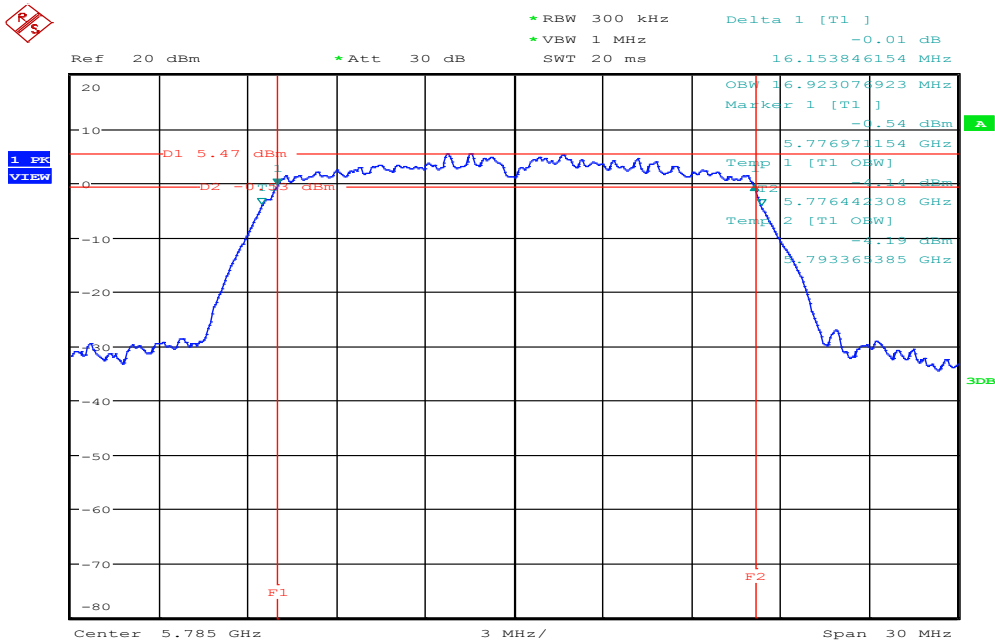

Date: 1.APR.2016 20:12:46

99% Bandwidth (CH High)

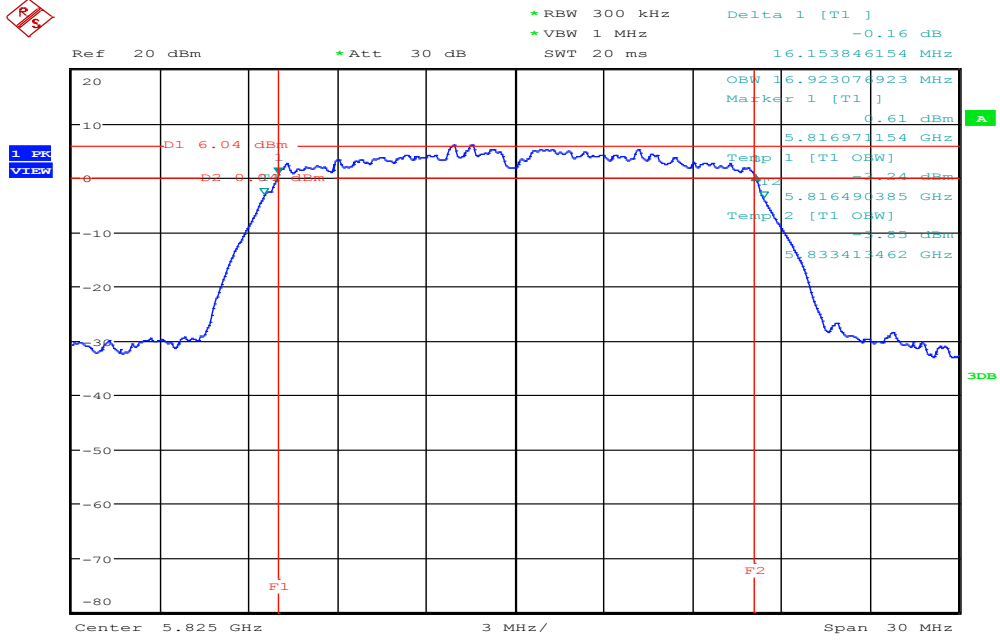

Date: 1.APR.2016 20:15:38

Test mode: IEEE 802.11n HT 20 MHz mode / 5745 ~ 5825MHz

99% Bandwidth (CH Low)

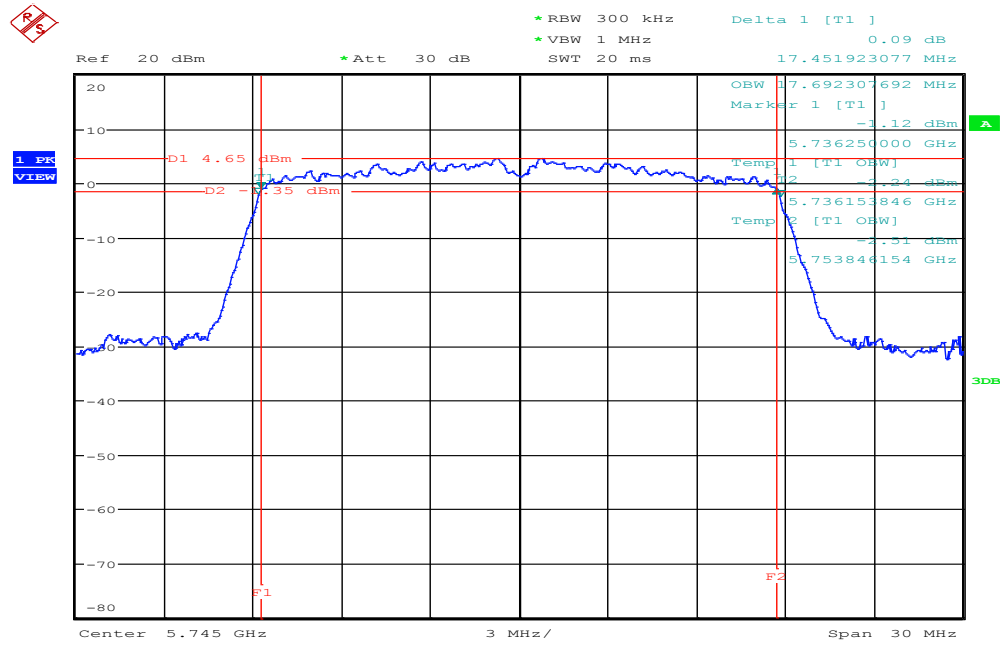

Date: 1.APR.2016 20:18:30

99% Bandwidth (CH Mid)

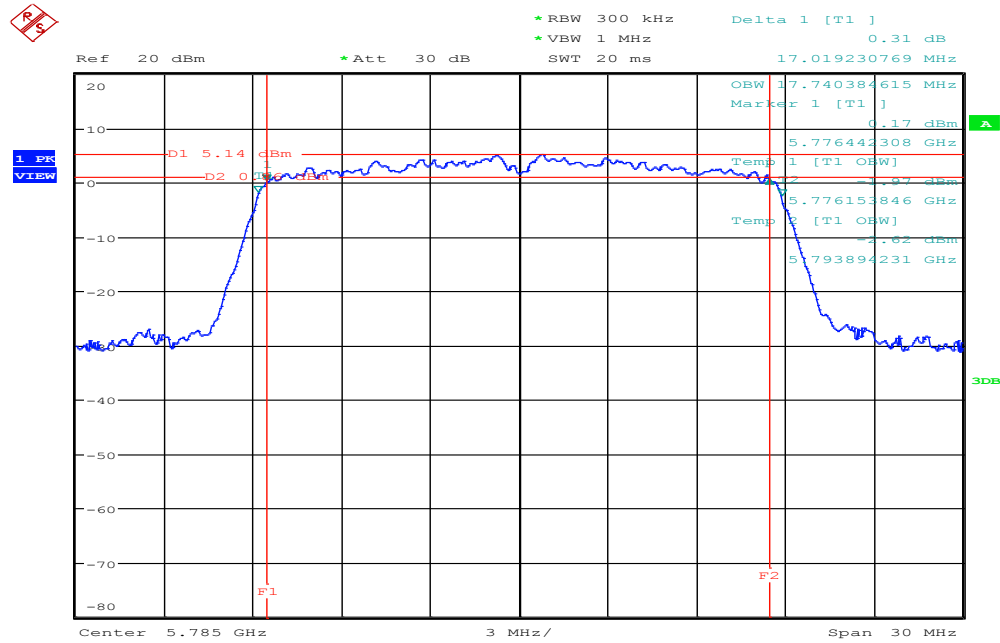

Date: 1.APR.2016 20:21:12

99% Bandwidth (CH High)

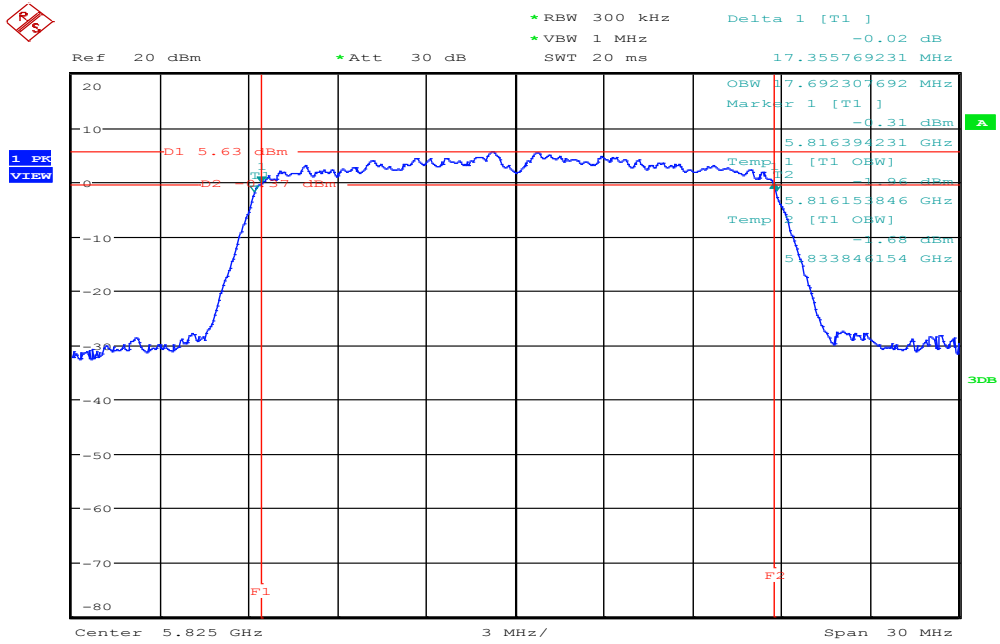

Date: 1.APR.2016 20:24:12

Test mode: IEEE 802.11n HT 40 MHz mode / 5755 ~ 5795MHz

99% Bandwidth (CH Low)

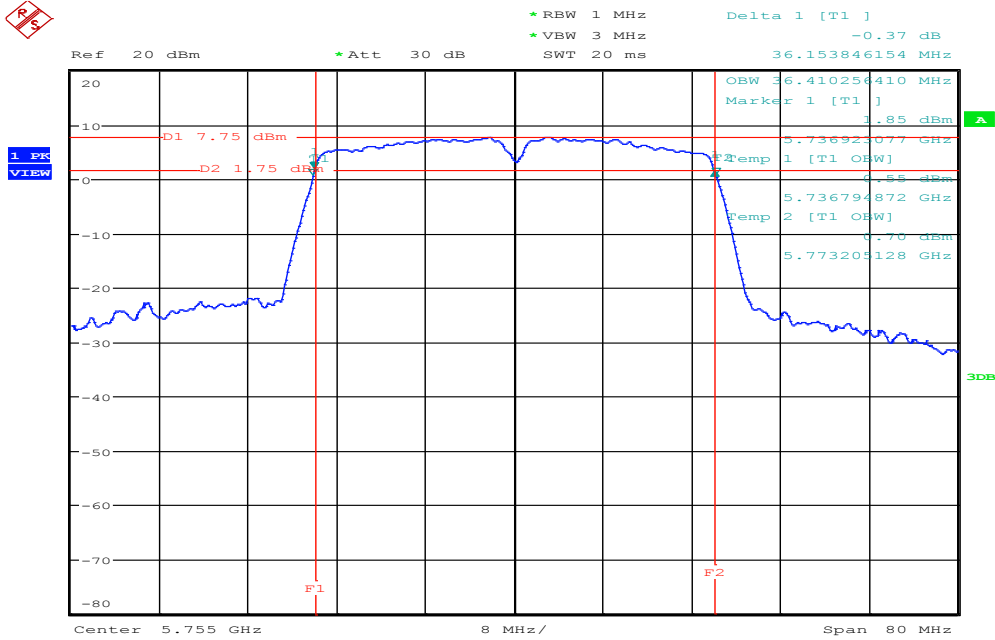

Date: 1.APR.2016 19:34:57

99% Bandwidth (CH High)

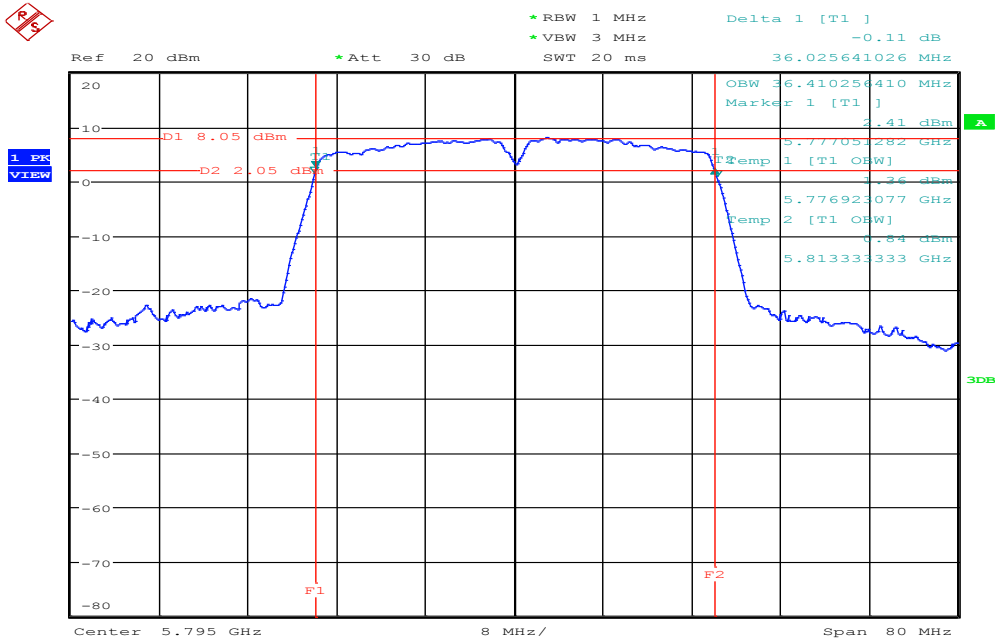

Date: 1.APR.2016 19:37:54

7.2 6DB BANDWIDTH

LIMIT

According to §15.407 & RSS-247§, systems using digital modulation techniques may operate in the 902 - 928 MHz, 2400 - 2483.5 MHz, and 5725 - 5850 MHz bands. The minimum 6dB bandwidth shall be at least 500 kHz.

Test Configuration

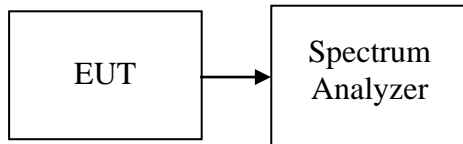

TEST PROCEDURE

1. Place the EUT on the table and set it in the transmitting mode.
2. Remove the antenna from the EUT and then connect a low loss RF cable from the antenna port to the spectrum analyzer.
3. Set the spectrum analyzer as RBW = VBW = 100kHz, Span = 50MHz, Sweep = auto.
4. Mark the peak frequency and -6dB (upper and lower) frequency.
5. Repeat until all the rest channels are investigated.

TEST RESULTS

No non-compliance noted

Test Data**Test mode: IEEE 802.11a mode**

Channel	Frequency (MHz)	6dB Bandwidth (MHz)	Limit (kHz)	Result
Low	5745	16.4423	>500	PASS
Mid	5785	16.3461		PASS
High	5825	16.3942		PASS

Test mode: IEEE 802.11n HT 20 MHz mode

Channel	Frequency (MHz)	6dB Bandwidth (MHz)	Limit (kHz)	Result
Low	5745	17.5480	>500	PASS
Mid	5785	17.5480		PASS
High	5825	17.5480		PASS

Test mode: IEEE 802.11n HT 40 MHz mode

Channel	Frequency (MHz)	6dB Bandwidth (MHz)	Limit (kHz)	Result
Low	5755	36.4102	>500	PASS
High	5795	36.2820		PASS

Test Plot

IEEE 802.11a mode / 5745 ~ 5825MHz

6dB Bandwidth (CH Low)

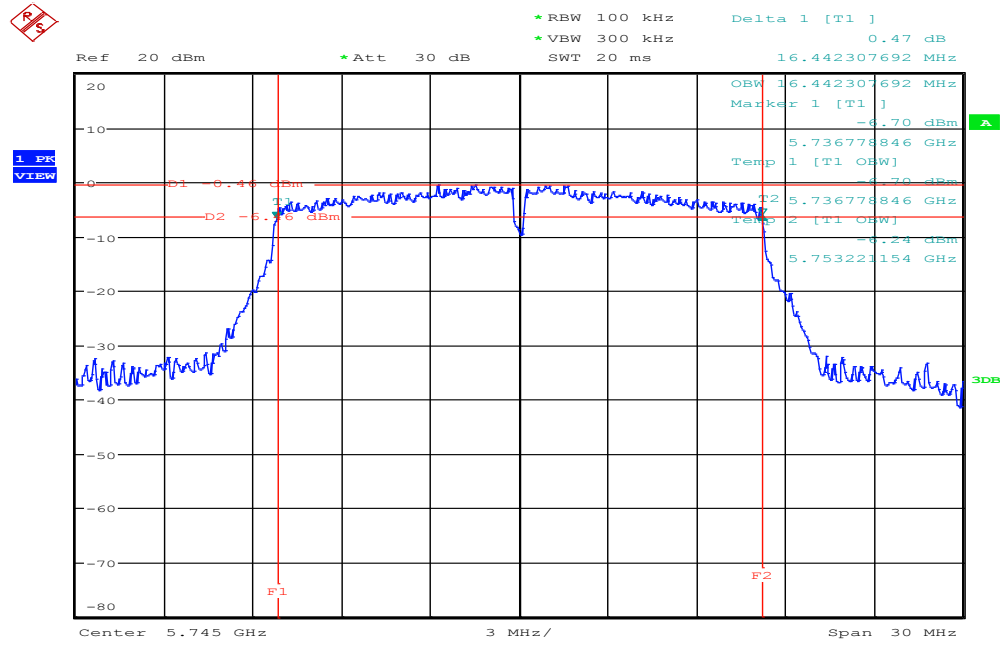

Date: 1.APR.2016 20:08:11

6dB Bandwidth (CH Mid)

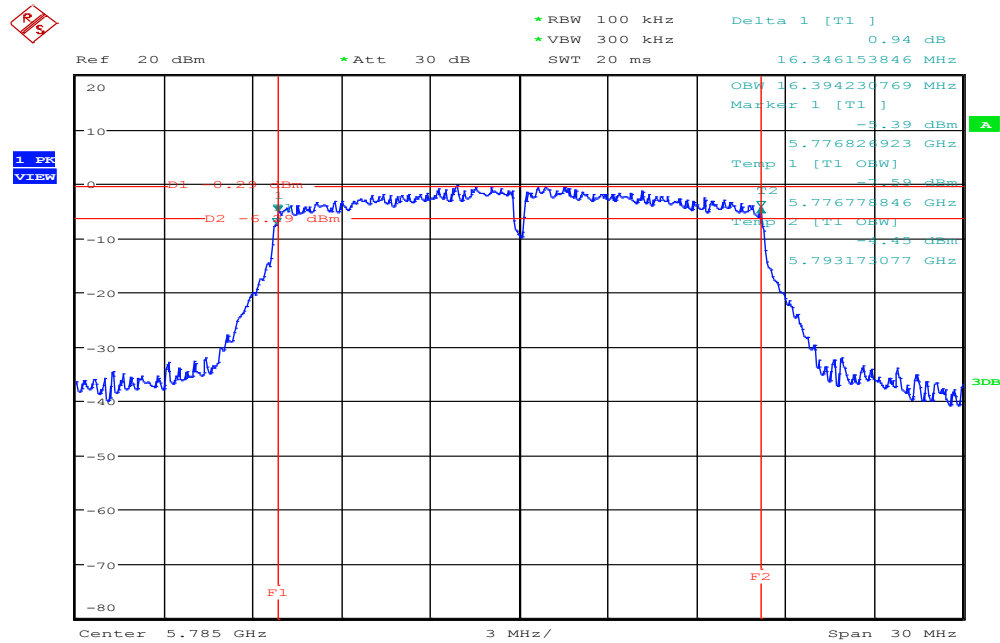

Date: 1.APR.2016 20:02:08

6dB Bandwidth (CH High)

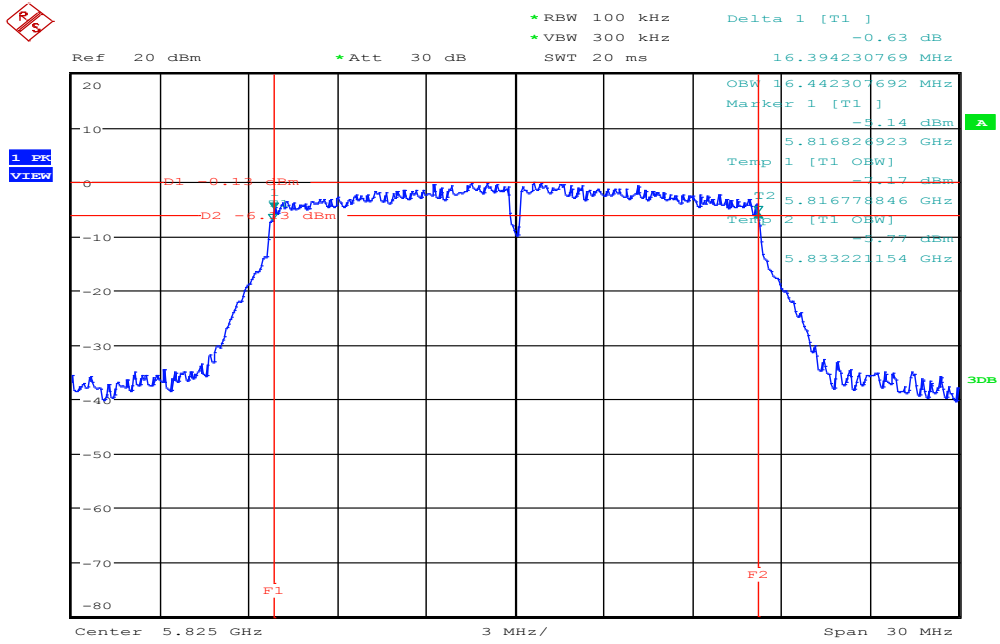

Date: 1.APR.2016 20:03:33

IEEE 802.11n HT 20 MHz mode / 5745 ~ 5825MHz

6dB Bandwidth (CH Low)

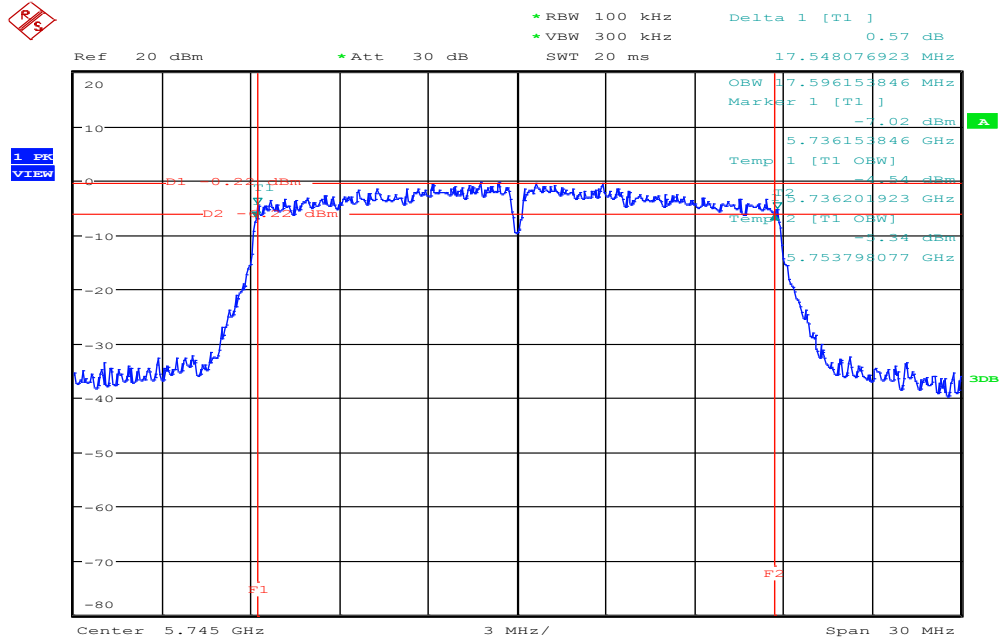

Date: 1.APR.2016 20:30:30

6dB Bandwidth (CH Mid)

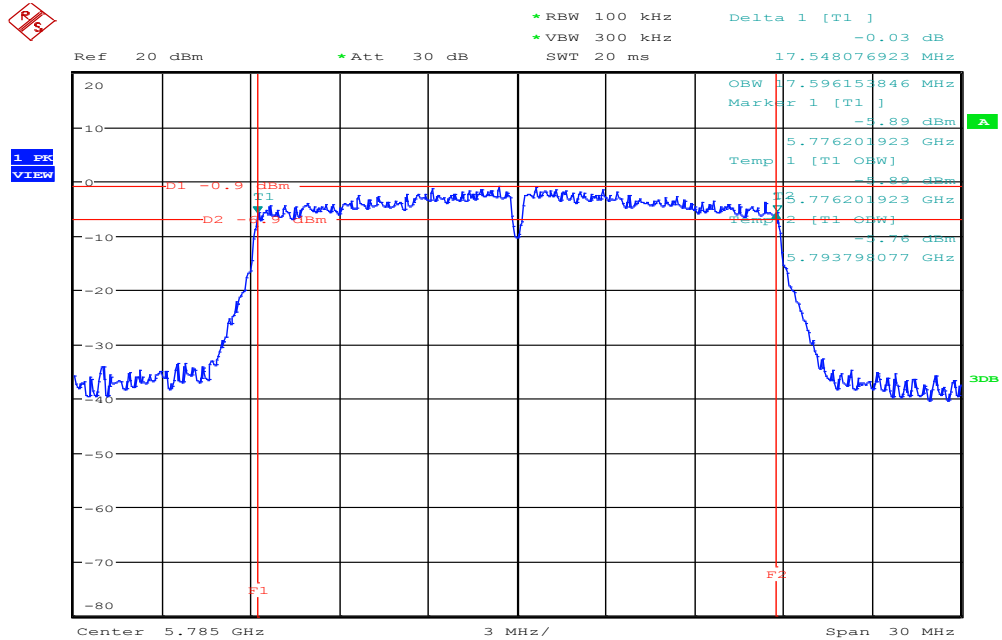

Date: 1.APR.2016 20:28:52

6dB Bandwidth (CH High)

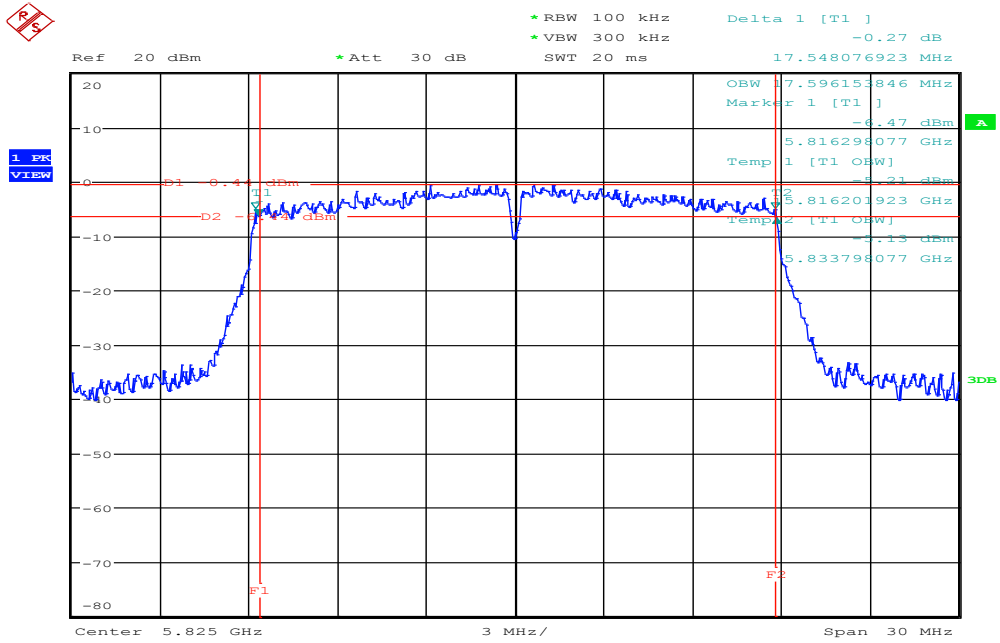

Date: 1.APR.2016 20:27:04

IEEE 802.11n HT 40 MHz mode / 5755 ~ 5815MHz

6dB Bandwidth (CH Low)

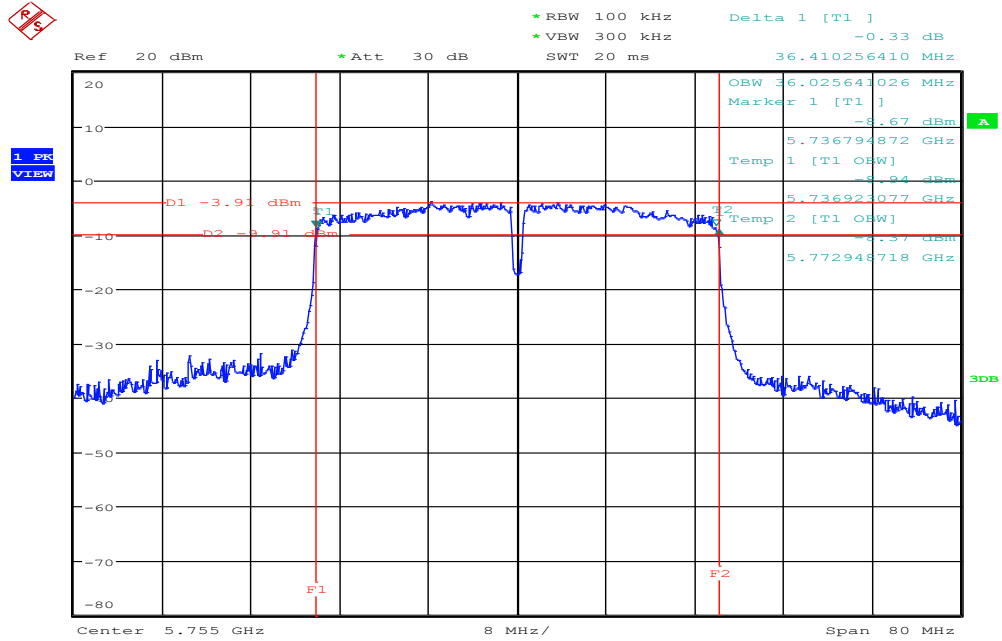

Date: 1.APR.2016 20:33:42

6dB Bandwidth (CH High)

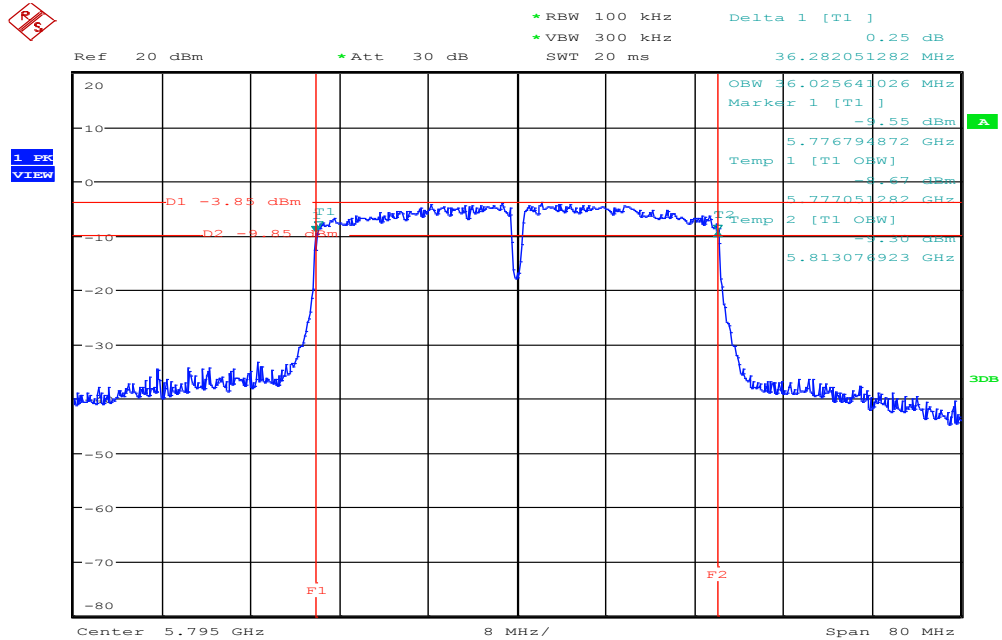

Date: 1.APR.2016 20:35:05

7.3 MAXIMUM CONDUCTED OUTPUT POWER

LIMIT

The maximum peak output power of the intentional radiator shall not exceed the following:

1. According to §15.407, for systems using digital modulation in the bands of 902-928 MHz, 2400-2483.5 MHz, and 5725-5850 MHz: 1 Watt.
2. According to RSS-247 §, for systems employing digital modulation techniques operating in the bands 902-928 MHz, 2400-2483.5 MHz and 5725-5850 MHz, the maximum peak conducted output power shall not exceed 1 W.

Test Configuration

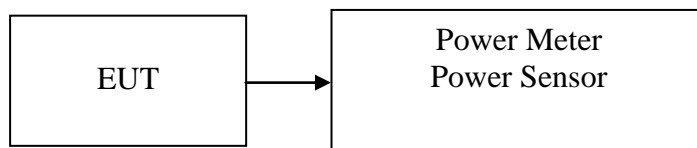

TEST PROCEDURE

The transmitter output is connected to the Power Meter. The Power Meter is set to the peak power detection.

TEST RESULTS

No non-compliance noted

Test Data**Test mode: IEEE 802.11a mode / 5745 ~ 5825MHz**

Channel	Frequency (MHz)	Output Power (dBm)	Output Power (W)	Limit (dBm)
Low	5745	13.03	0.0201	30.00
Mid	5785	*13.14	0.0206	30.00
High	5825	13.01	0.0200	30.00

Test mode: IEEE 802.11n HT 20 MHz mode / 5745 ~ 5825MHz

Channel	Frequency (MHz)	Output Power (dBm)	Output Power (W)	Limit (dBm)
Low	5745	*13.20	0.0209	30.00
Mid	5785	13.06	0.0202	30.00
High	5825	13.02	0.0200	30.00

Test mode: IEEE 802.11n HT 40 MHz mode / 5755 ~ 5795MHz

Channel	Frequency (MHz)	Output Power (dBm)	Output Power (W)	Limit (dBm)
Low	5755	13.26	0.0212	30.00
High	5795	*13.48	0.0223	30.00

7.4 BAND EDGES MEASUREMENT

LIMIT

According to §15.407 & RSS-247 §, in any 100 kHz bandwidth outside the frequency bands in which the spread spectrum intentional radiator is operating, the radio frequency power that is produced by the intentional radiator shall be at least 20 dB below that in the 100 kHz bandwidth within the band that contains the highest level of the desired power, based on either an RF conducted or a radiated measurement, provided the transmitter demonstrates compliance with the peak conducted power limits. In addition, radiated emissions which fall in the restricted bands, as defined in §15.205(a), must also comply with the radiated emission limits specified in 15.209(a) (see Section 15.205(c)).

Test Configuration

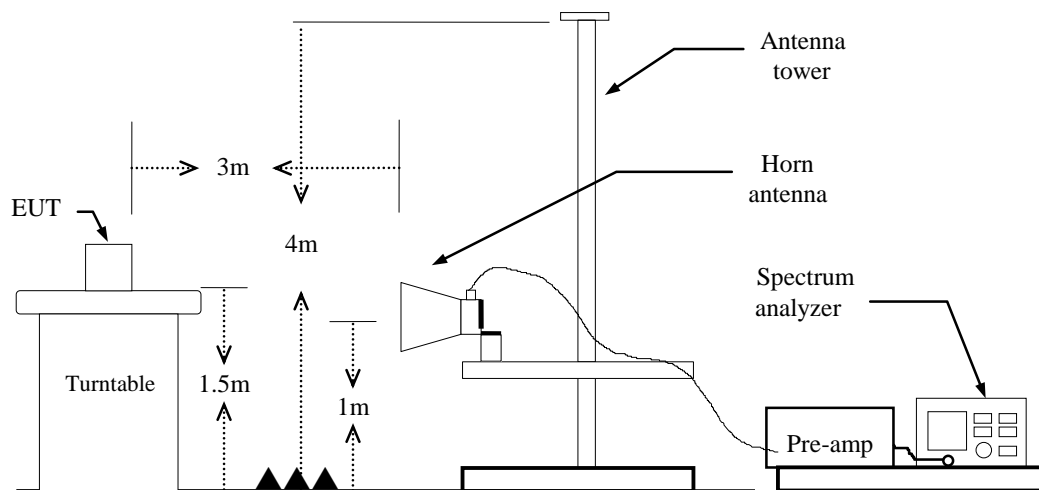

TEST PROCEDURE

1. The EUT is placed on a turntable, which is 1.5m above the ground plane.
2. The turntable shall be rotated for 360 degrees to determine the position of maximum emission level.
3. EUT is set 3m away from the receiving antenna, which is varied from 1m to 4m to find out the highest emission.
4. Set the spectrum analyzer in the following setting in order to capture the lower and upper band-edges of the emission:
 - (a) PEAK: RBW=VBW=1MHz / Sweep=AUTO
 - (b) AVERAGE: RBW=1MHz,
if duty cycle $\geq 98\%$, VBW=10Hz.
if duty cycle $< 98\%$ VBW=1/T.
IEEE 802.11a mode: $\geq 98\%$, VBW=10Hz
IEEE 802.11n HT 20 MHz mode: $\geq 98\%$, VBW=10Hz
IEEE 802.11n HT 40 MHz mode: $\geq 98\%$, VBW=10Hz
5. Repeat the procedures until all the PEAK and AVERAGE versus POLARIZATION are measured.
6. Result = Spectrum Reading + cable loss(spectrum to Amp) - Amp Gain + Cable loss(Amp to receive Ant)+ Receive Ant

For Un-restricted Band Emissions

The peak output power procedure is used to measure the fundamental emission power to demonstrate compliance to requirements, then the peak conducted output power measured within any 100 kHz outside the authorized frequency band shall be attenuated by at least 20 dB relative to the maximum measured in-band peak PSD level.

TEST RESULTS

Refer to attach spectrum analyzer data chart.

IEEE 802.11a Mode / CH Low

Detector mode: Peak

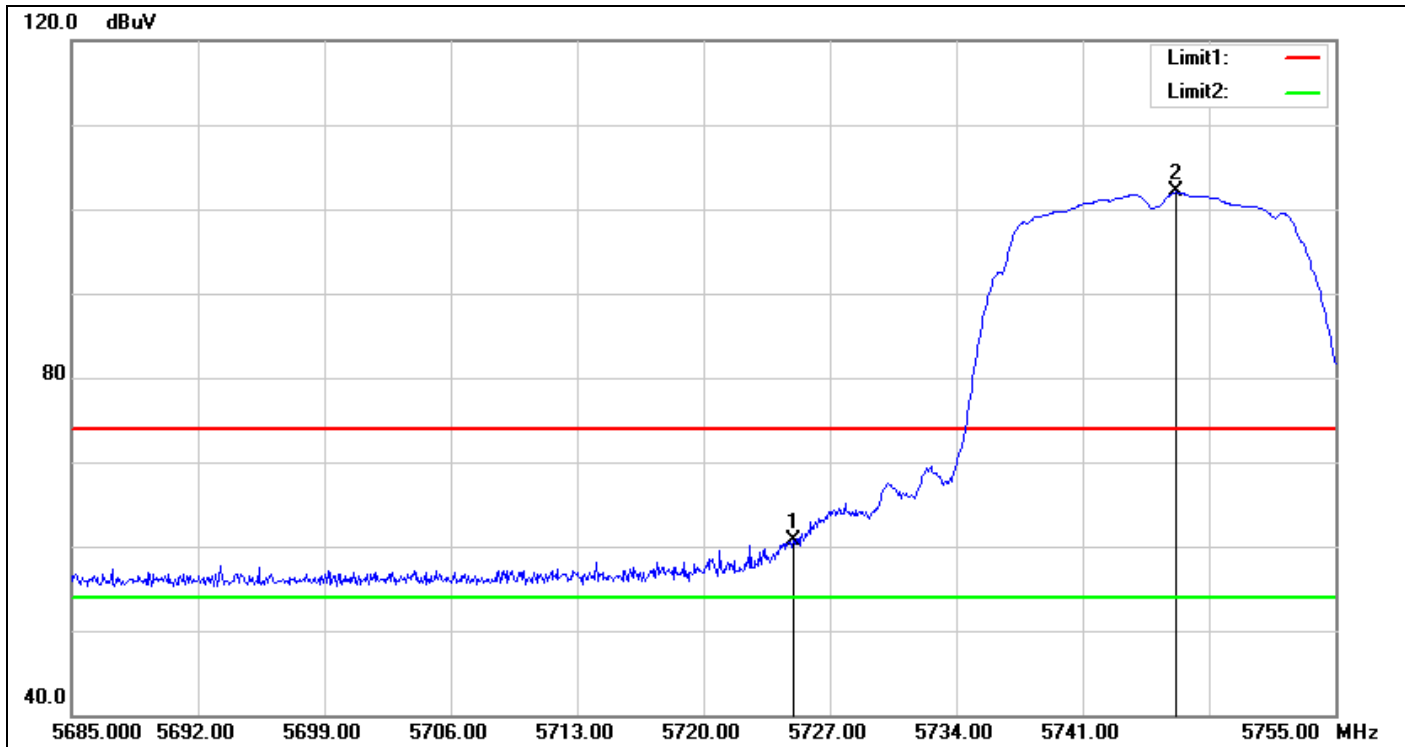

No.	Frequency (MHz)	Reading (dBuV)	Correct Factor(dB)	Result (dBuV)	Limit (dBuV)	Margin (dB)	Remark
1	5724.970	54.42	6.21	60.63	74.00	-13.37	peak
2	5746.180	95.71	6.30	102.01	74.00	28.01	peak

Detector mode: Average

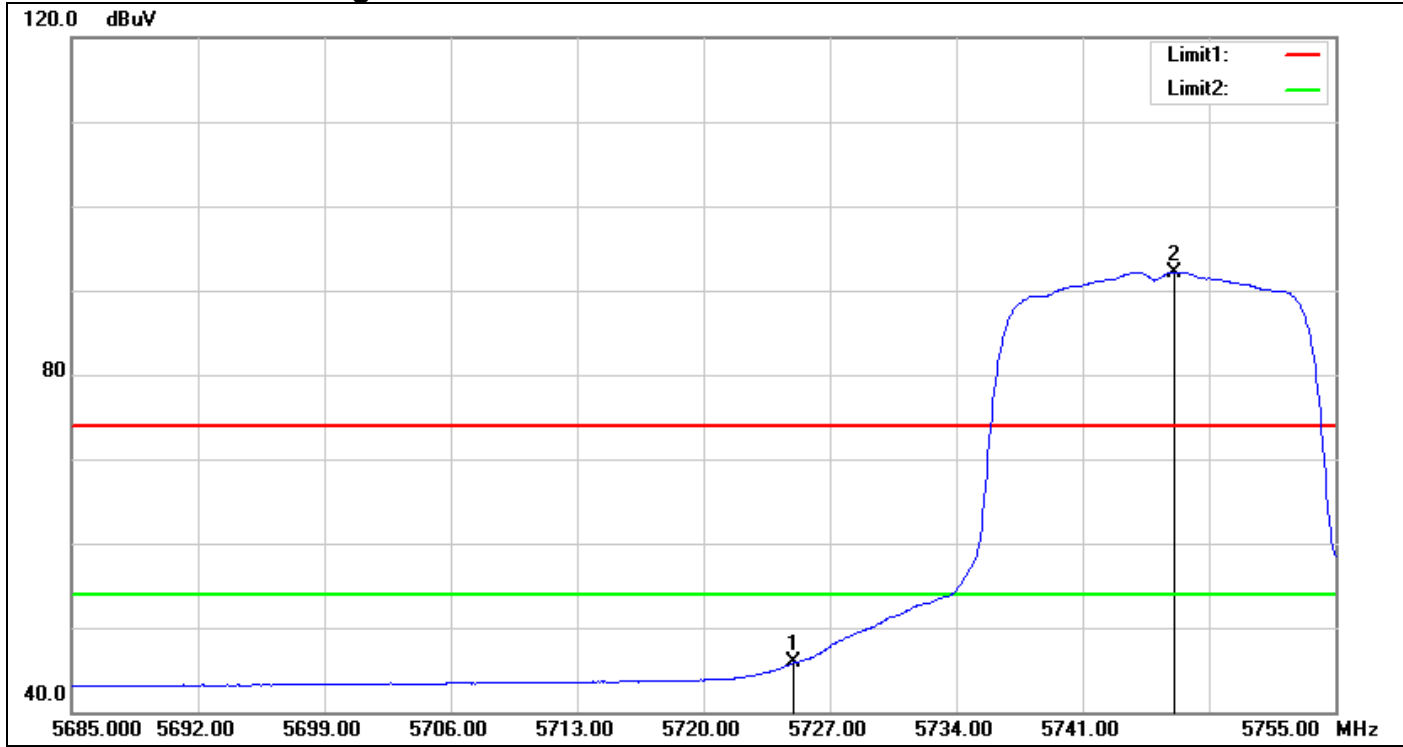

No.	Frequency (MHz)	Reading (dBuV)	Correct Factor(dB)	Result (dBuV)	Limit (dBuV)	Margin (dB)	Remark
1	5725.000	39.64	6.21	45.85	54.00	-8.15	AVG
2	5746.040	85.87	6.30	92.17	54.00	38.17	AVG

IEEE 802.11a Mode / CH Mid

Detector mode: Peak

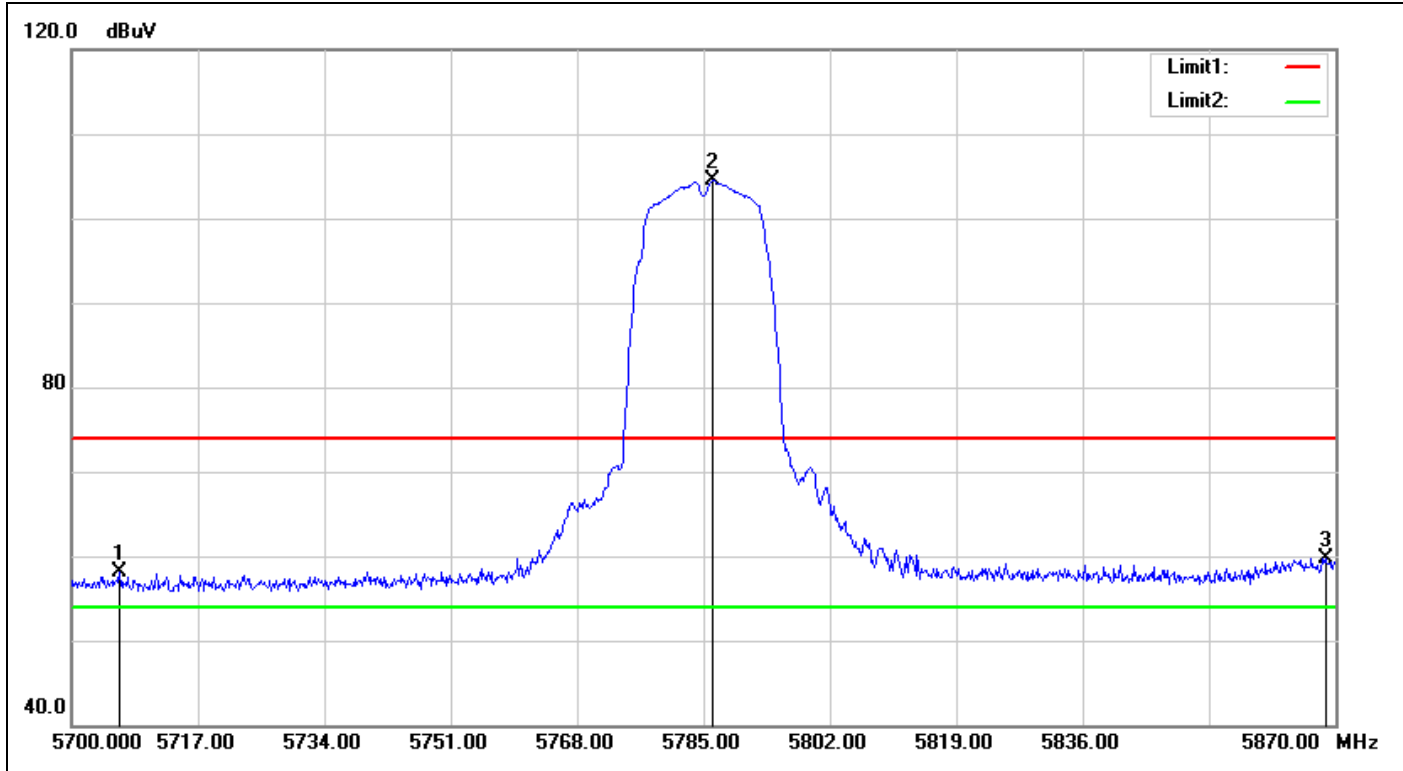

No.	Frequency (MHz)	Reading (dBuV)	Correct Factor(dB)	Result (dBuV)	Limit (dBuV)	Margin (dB)	Remark
1	5706.460	51.92	6.13	58.05	74.00	-15.95	peak
2	5786.190	98.00	6.47	104.47	74.00	30.47	peak
3	5868.640	52.95	6.82	59.77	74.00	-14.23	peak

Detector mode: Average

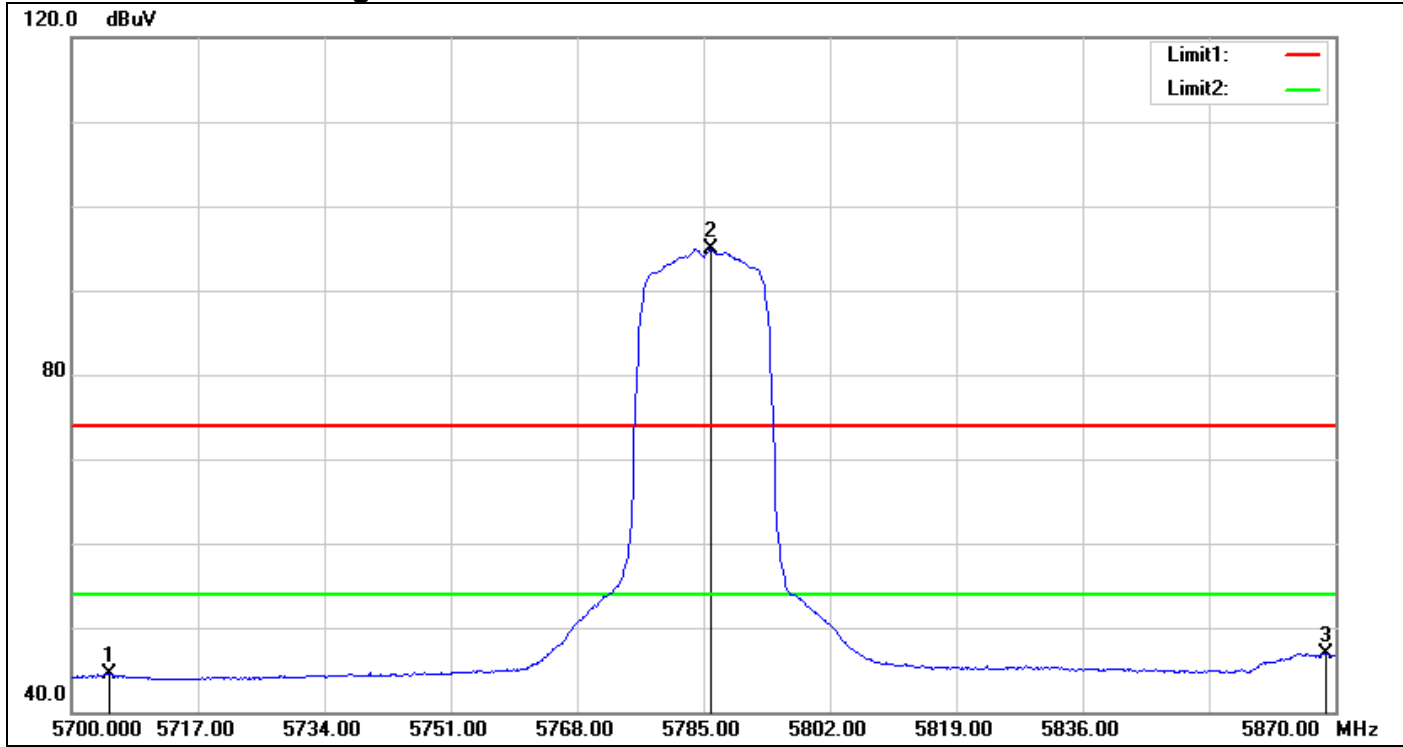

No.	Frequency (MHz)	Reading (dBuV)	Correct Factor(dB)	Result (dBuV)	Limit (dBuV)	Margin (dB)	Remark
1	5705.100	38.43	6.12	44.55	54.00	-9.45	AVG
2	5786.020	88.40	6.47	94.87	54.00	40.87	AVG
3	5868.640	40.14	6.82	46.96	54.00	-7.04	AVG

IEEE 802.11a Mode / CH High

Detector mode: Peak

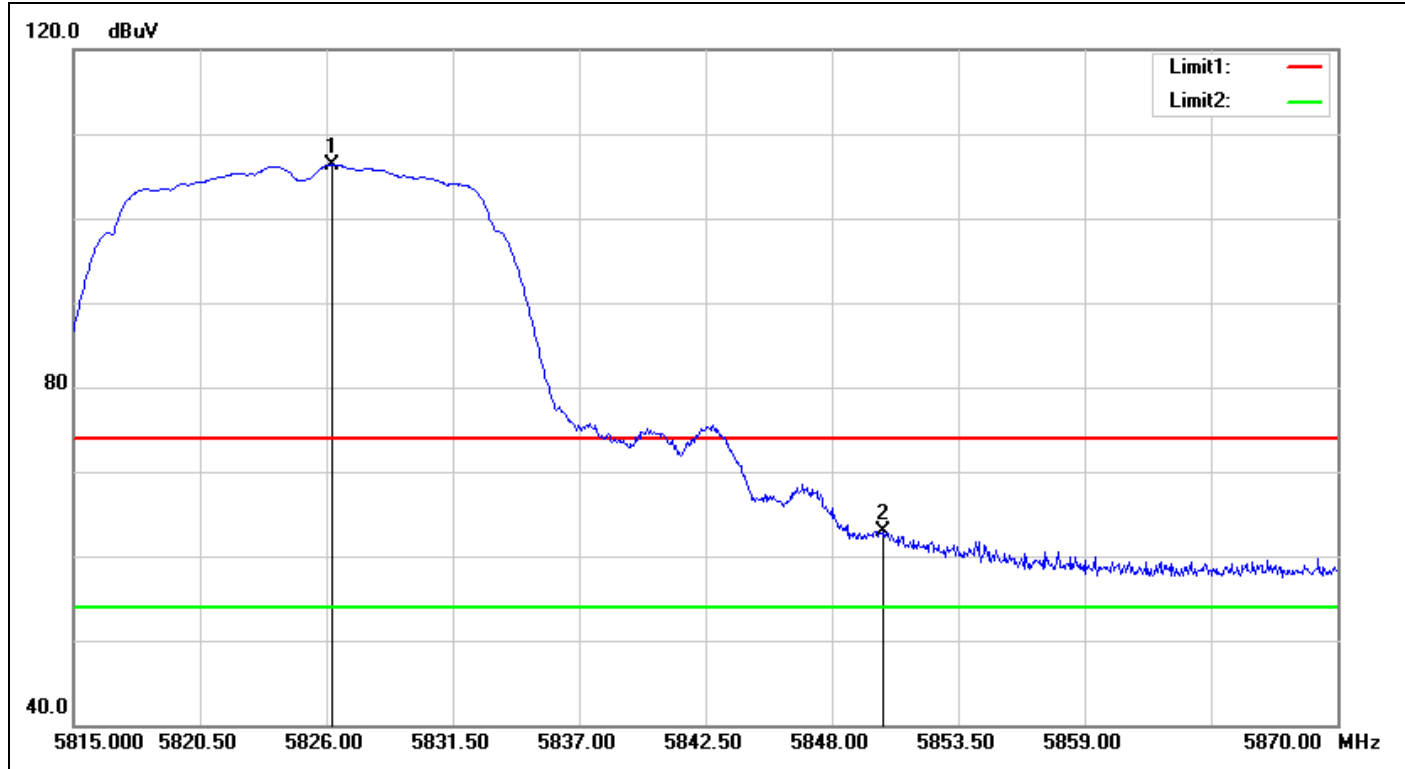

No.	Frequency (MHz)	Reading (dBuV)	Correct Factor(dB)	Result (dBuV)	Limit (dBuV)	Margin (dB)	Remark
1	5826.220	99.76	6.64	106.40	74.00	32.40	peak
2	5850.200	56.18	6.74	62.92	74.00	-11.08	peak

Detector mode: Average

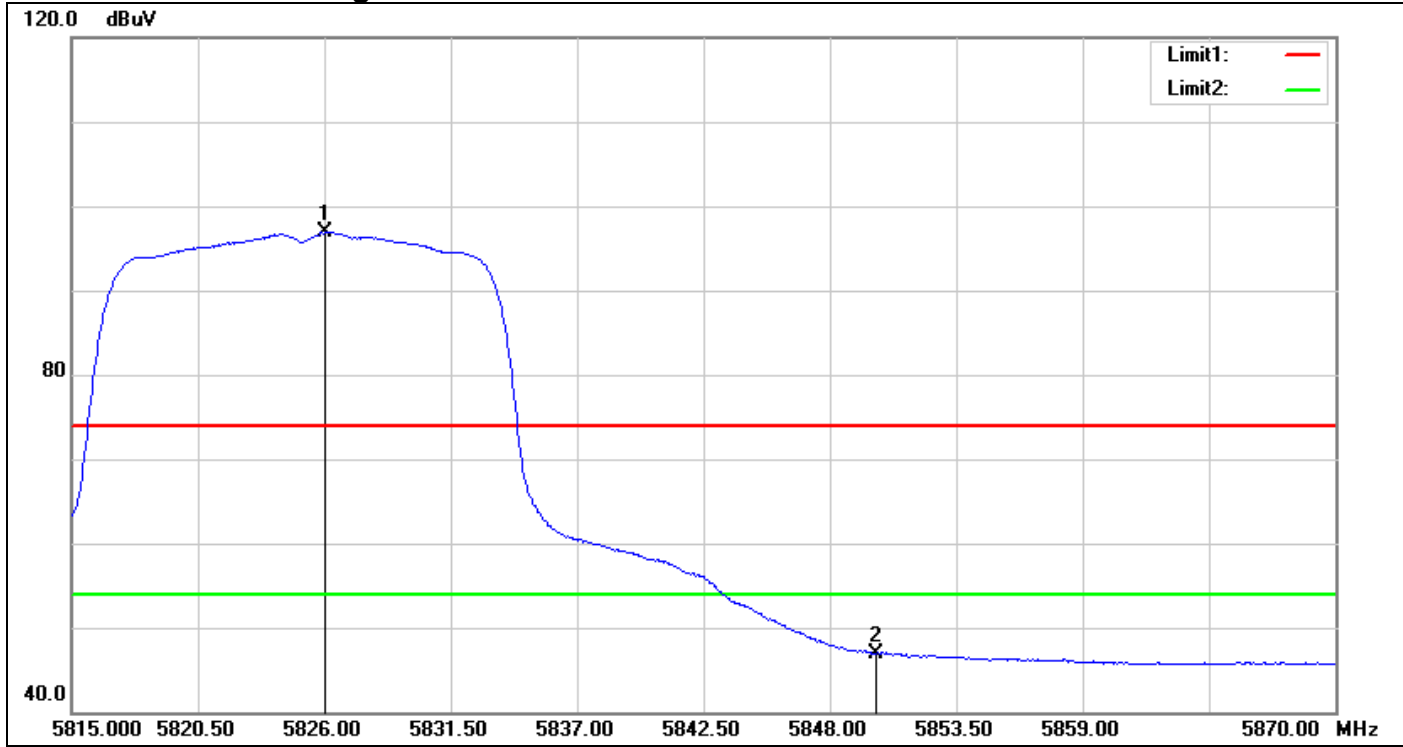

No.	Frequency (MHz)	Reading (dBuV)	Correct Factor(dB)	Result (dBuV)	Limit (dBuV)	Margin (dB)	Remark
1	5826.055	90.26	6.64	96.90	54.00	42.90	AVG
2	5850.000	40.26	6.74	47.00	54.00	-7.00	AVG

IEEE 802.11n HT20 MHz Mode / CH Low

Detector mode: Peak

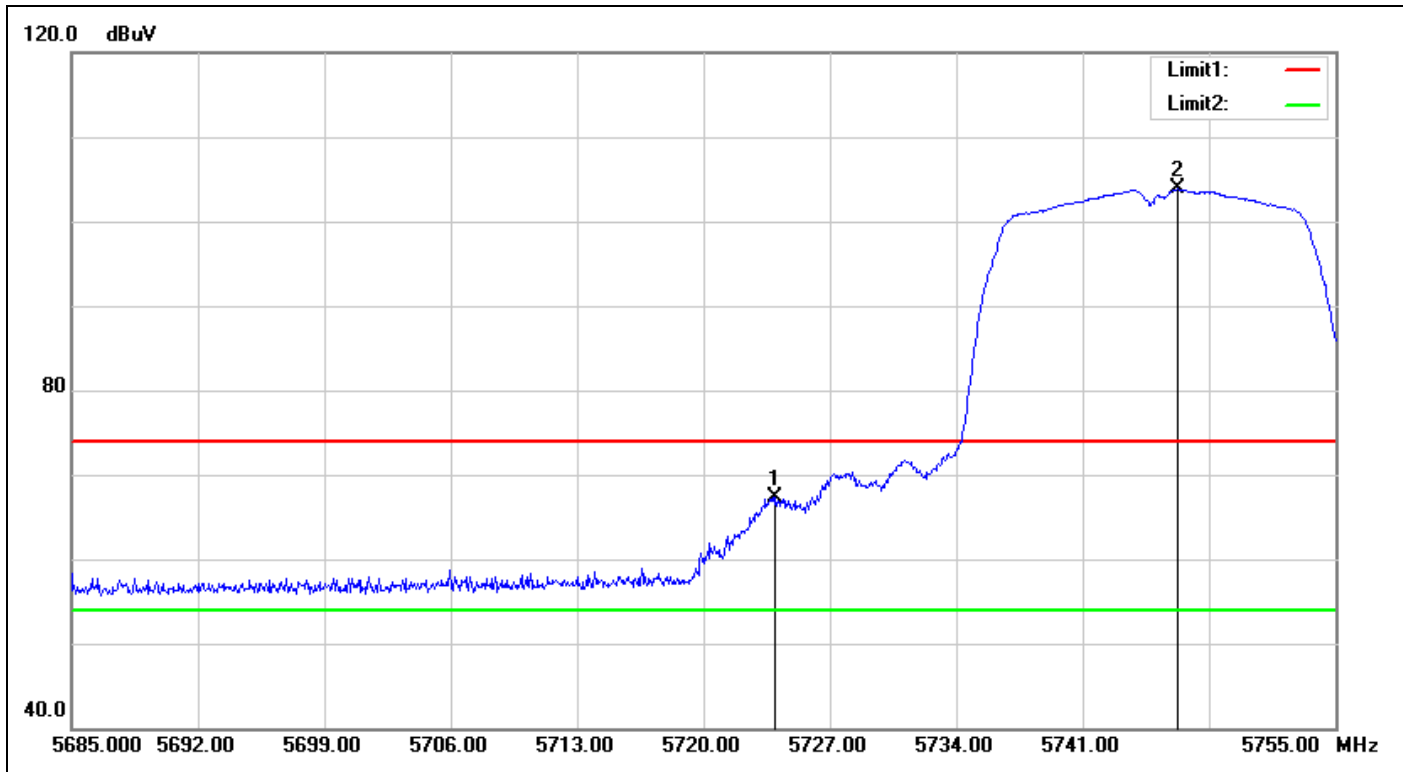

No.	Frequency (MHz)	Reading (dBuV)	Correct Factor(dB)	Result (dBuV)	Limit (dBuV)	Margin (dB)	Remark
1	5723.990	61.18	6.20	67.38	74.00	-6.62	peak
2	5746.250	97.51	6.30	103.81	74.00	29.81	peak

Detector mode: Average

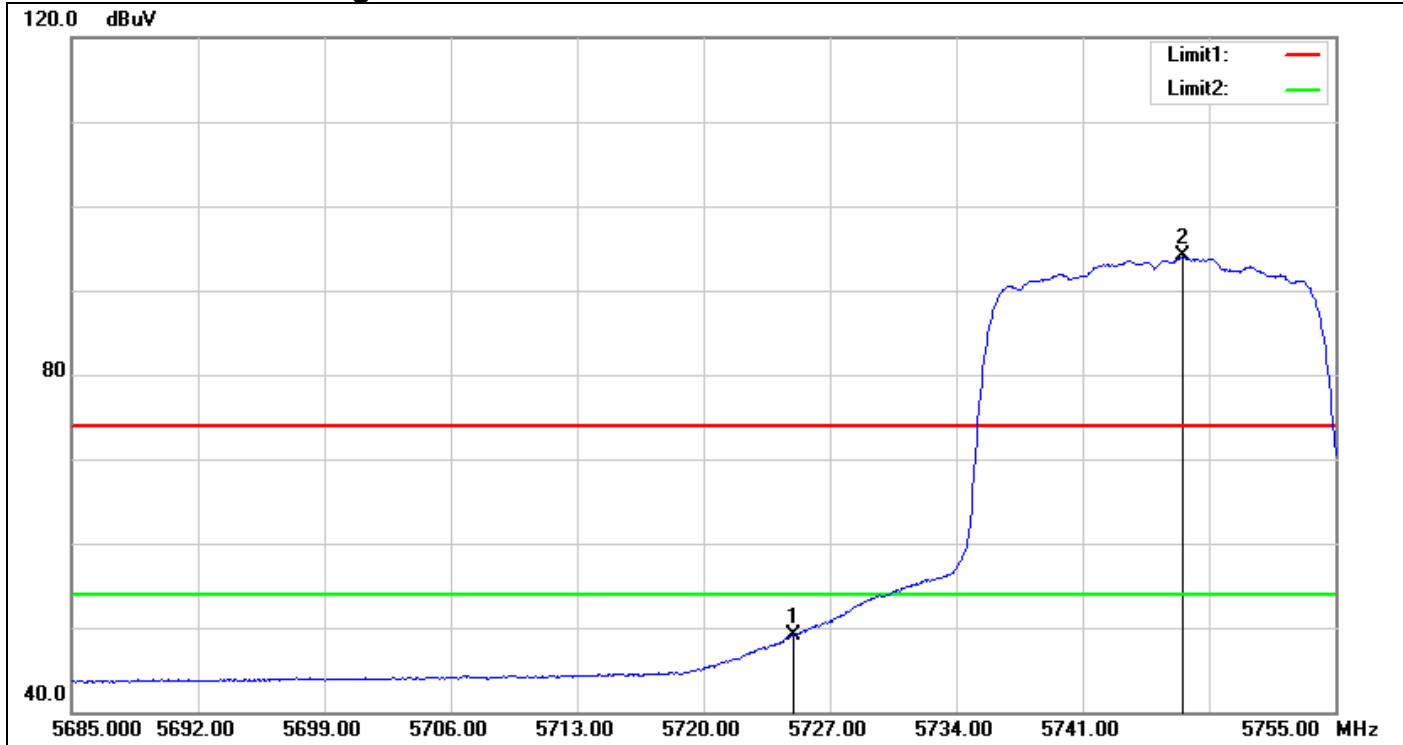

No.	Frequency (MHz)	Reading (dBuV)	Correct Factor(dB)	Result (dBuV)	Limit (dBuV)	Margin (dB)	Remark
1	5725.000	42.92	6.21	49.13	54.00	-4.87	AVG
2	5746.530	87.74	6.30	94.04	54.00	40.04	AVG

IEEE 802.11n HT20 MHz Mode / CH Mid

Detector mode: Peak

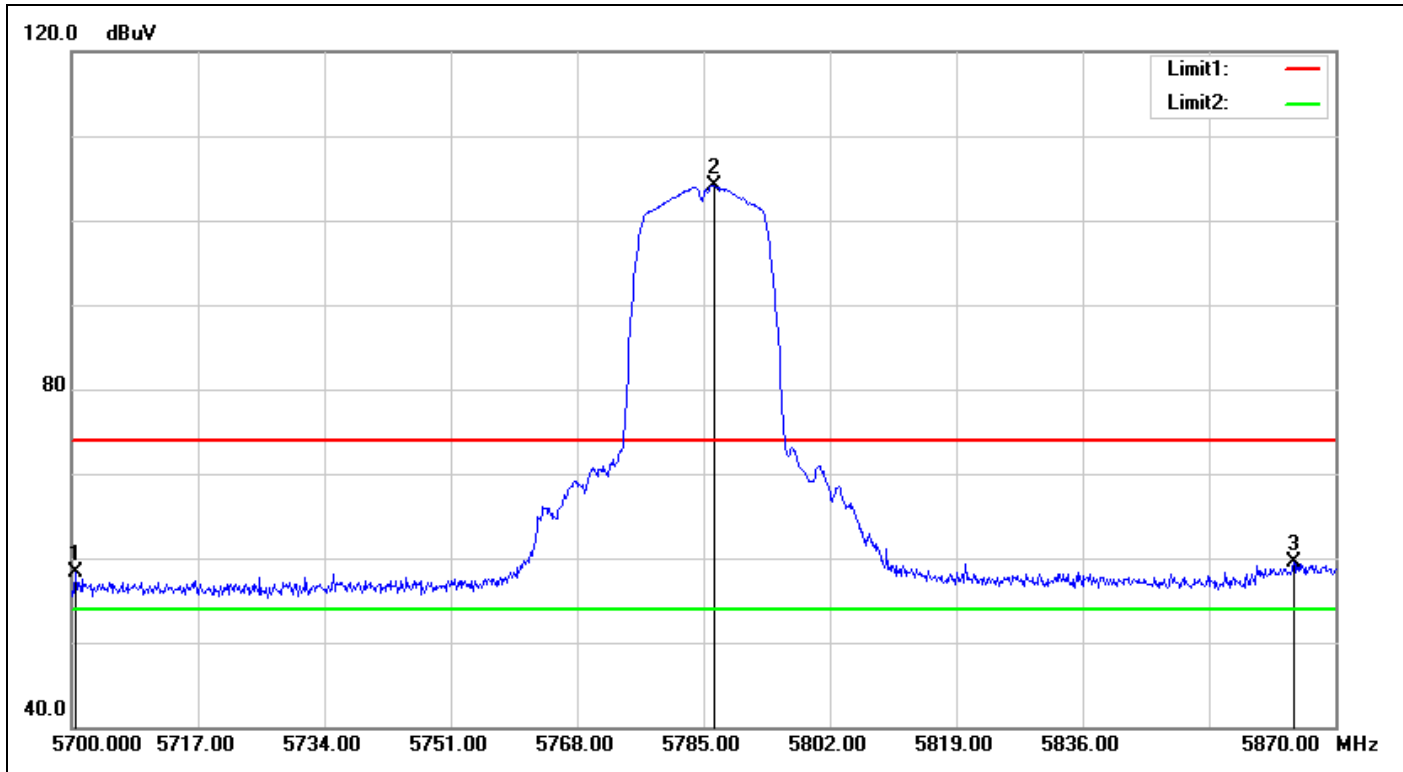

No.	Frequency (MHz)	Reading (dBuV)	Correct Factor(dB)	Result (dBuV)	Limit (dBuV)	Margin (dB)	Remark
1	5700.510	52.24	6.10	58.34	74.00	-15.66	peak
2	5786.360	97.67	6.47	104.14	74.00	30.14	peak
3	5864.390	52.71	6.80	59.51	74.00	-14.49	peak

Detector mode: Average

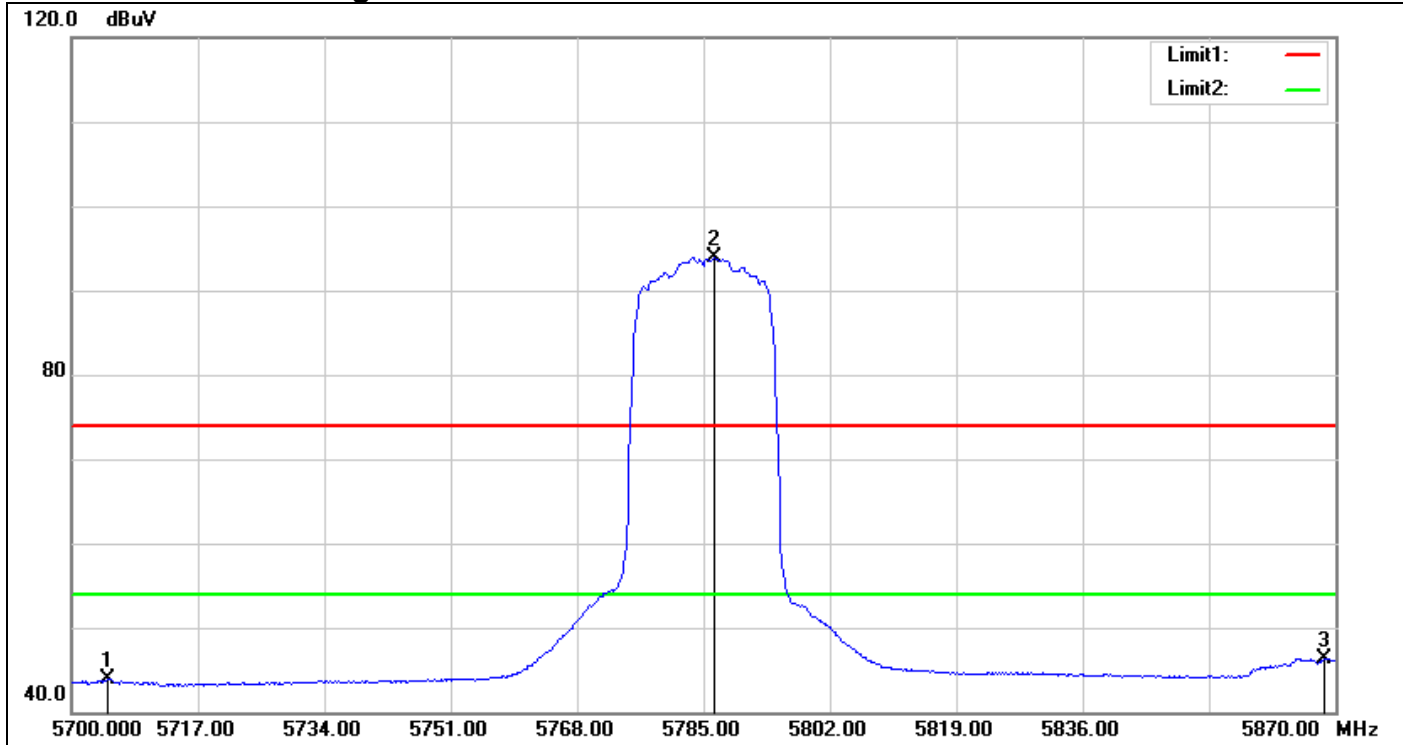

No.	Frequency (MHz)	Reading (dBuV)	Correct Factor(dB)	Result (dBuV)	Limit (dBuV)	Margin (dB)	Remark
1	5704.760	37.82	6.12	43.94	54.00	-10.06	AVG
2	5786.530	87.42	6.47	93.89	54.00	39.89	AVG
3	5868.470	39.53	6.82	46.35	54.00	-7.65	AVG

IEEE 802.11n HT20 MHz Mode / CH High

Detector mode: Peak

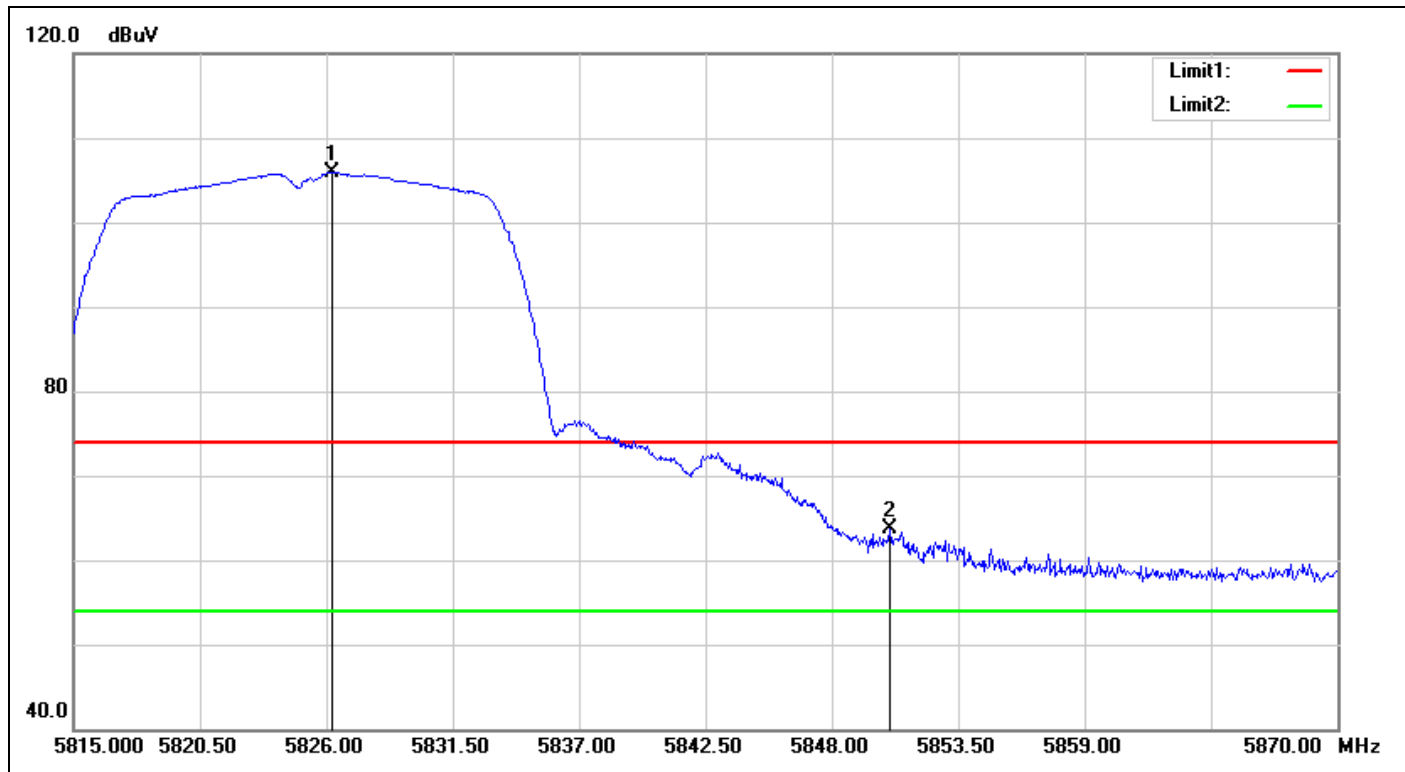

No.	Frequency (MHz)	Reading (dBuV)	Correct Factor(dB)	Result (dBuV)	Limit (dBuV)	Margin (dB)	Remark
1	5826.220	99.35	6.64	105.99	74.00	31.99	peak
2	5850.530	56.91	6.74	63.65	74.00	-10.35	peak

Detector mode: Average

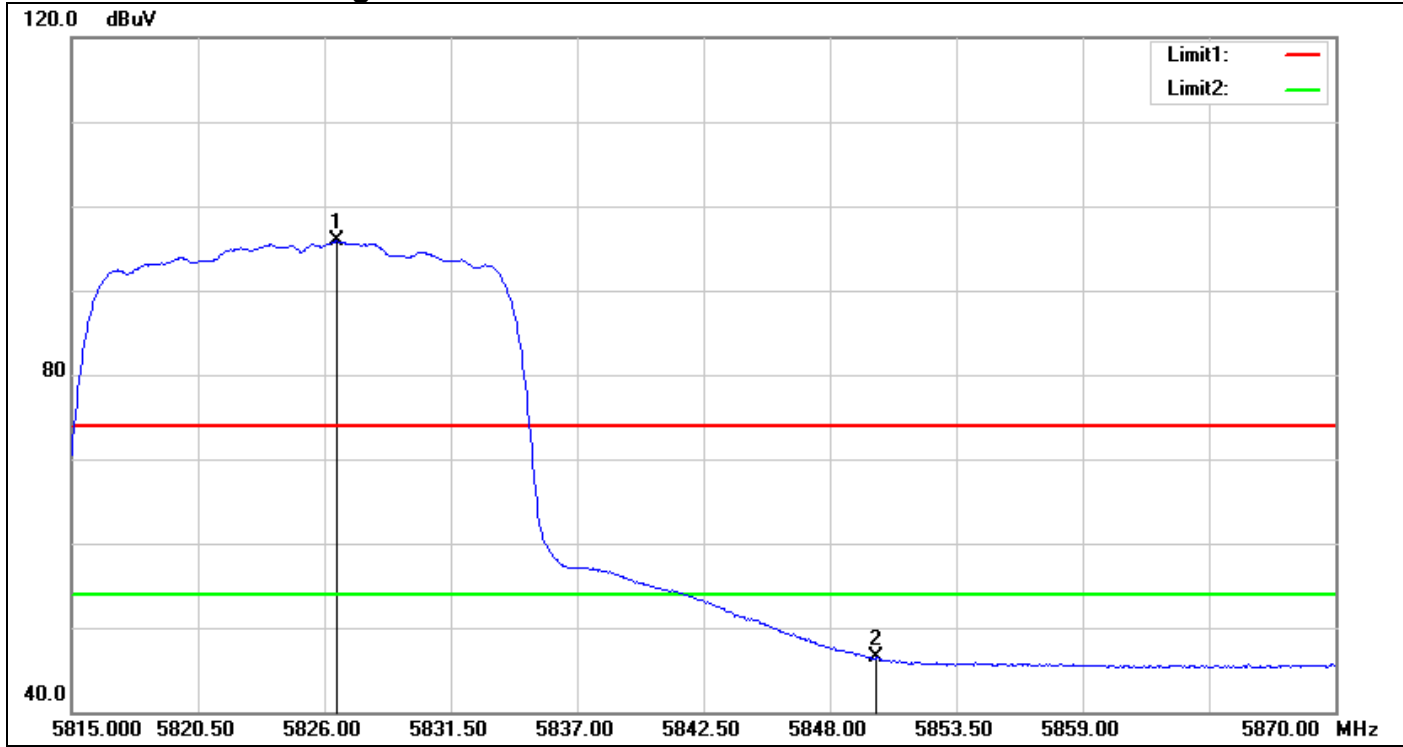

No.	Frequency (MHz)	Reading (dBuV)	Correct Factor(dB)	Result (dBuV)	Limit (dBuV)	Margin (dB)	Remark
1	5826.550	89.28	6.64	95.92	54.00	41.92	AVG
2	5850.035	39.78	6.74	46.52	54.00	-7.48	AVG

IEEE 802.11n HT40 MHz Mode / CH Low

Detector mode: Peak

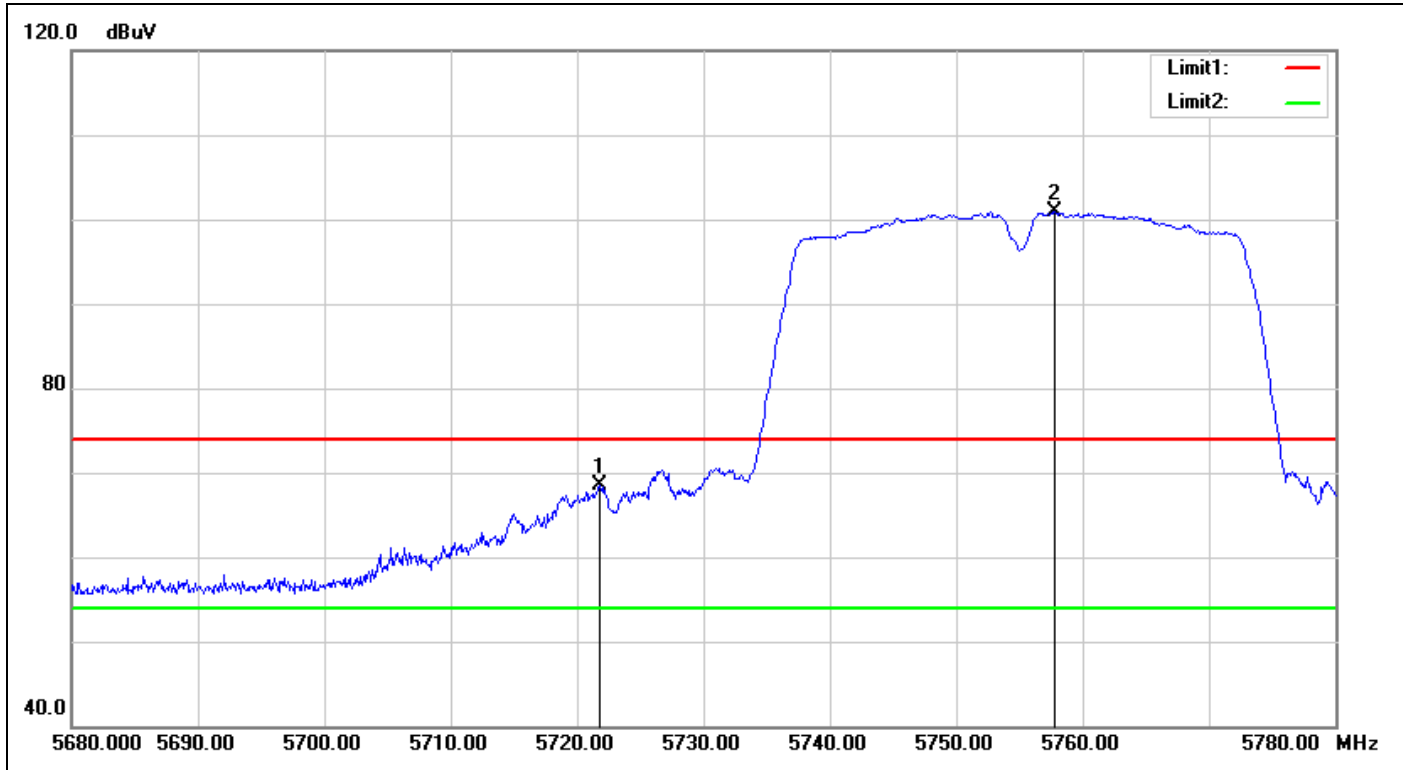

No.	Frequency (MHz)	Reading (dBuV)	Correct Factor(dB)	Result (dBuV)	Limit (dBuV)	Margin (dB)	Remark
1	5721.800	62.32	6.19	68.51	74.00	-5.49	peak
2	5757.800	94.55	6.35	100.90	74.00	26.90	peak

Detector mode: Average

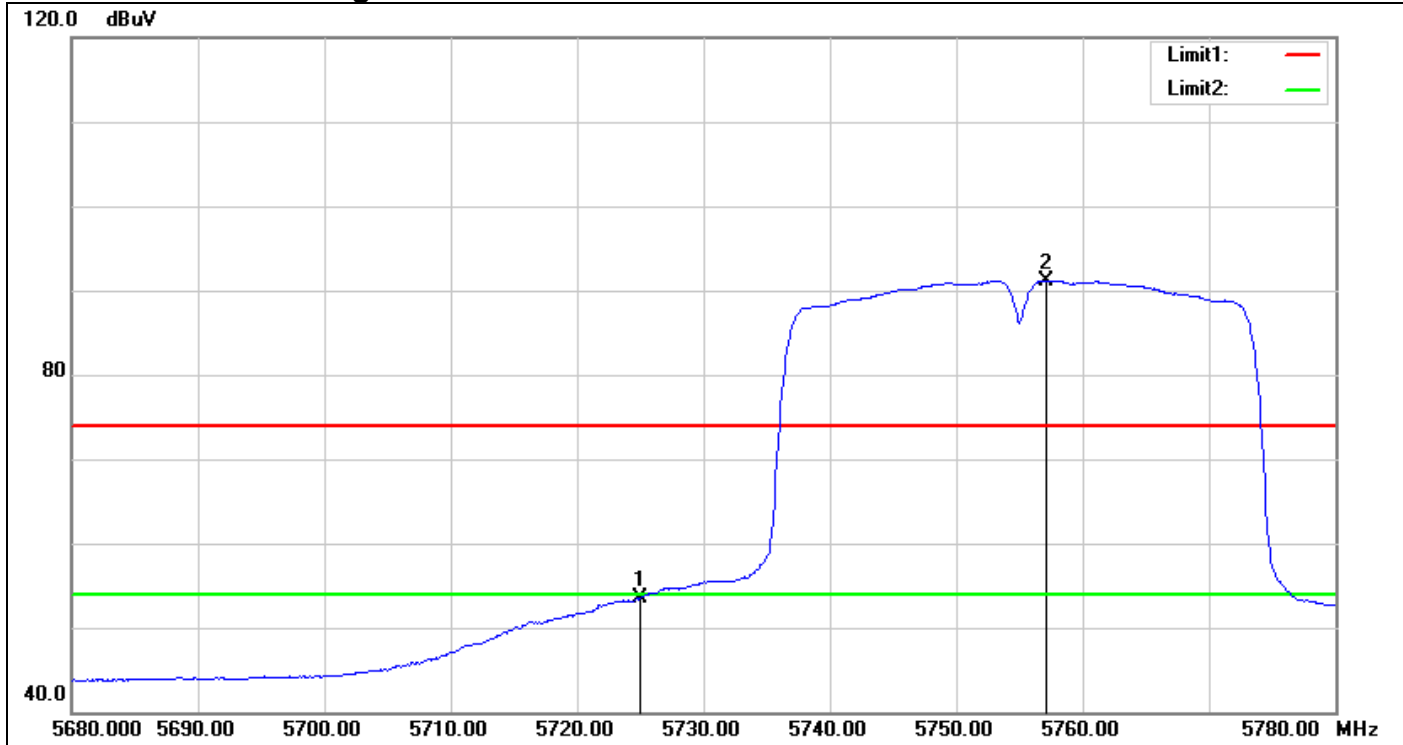

No.	Frequency (MHz)	Reading (dBuV)	Correct Factor(dB)	Result (dBuV)	Limit (dBuV)	Margin (dB)	Remark
1	5725.000	47.28	6.21	53.49	54.00	-0.51	AVG
2	5757.100	84.83	6.35	91.18	54.00	37.18	AVG

IEEE 802.11n HT40 MHz Mode / CH High

Detector mode: Peak

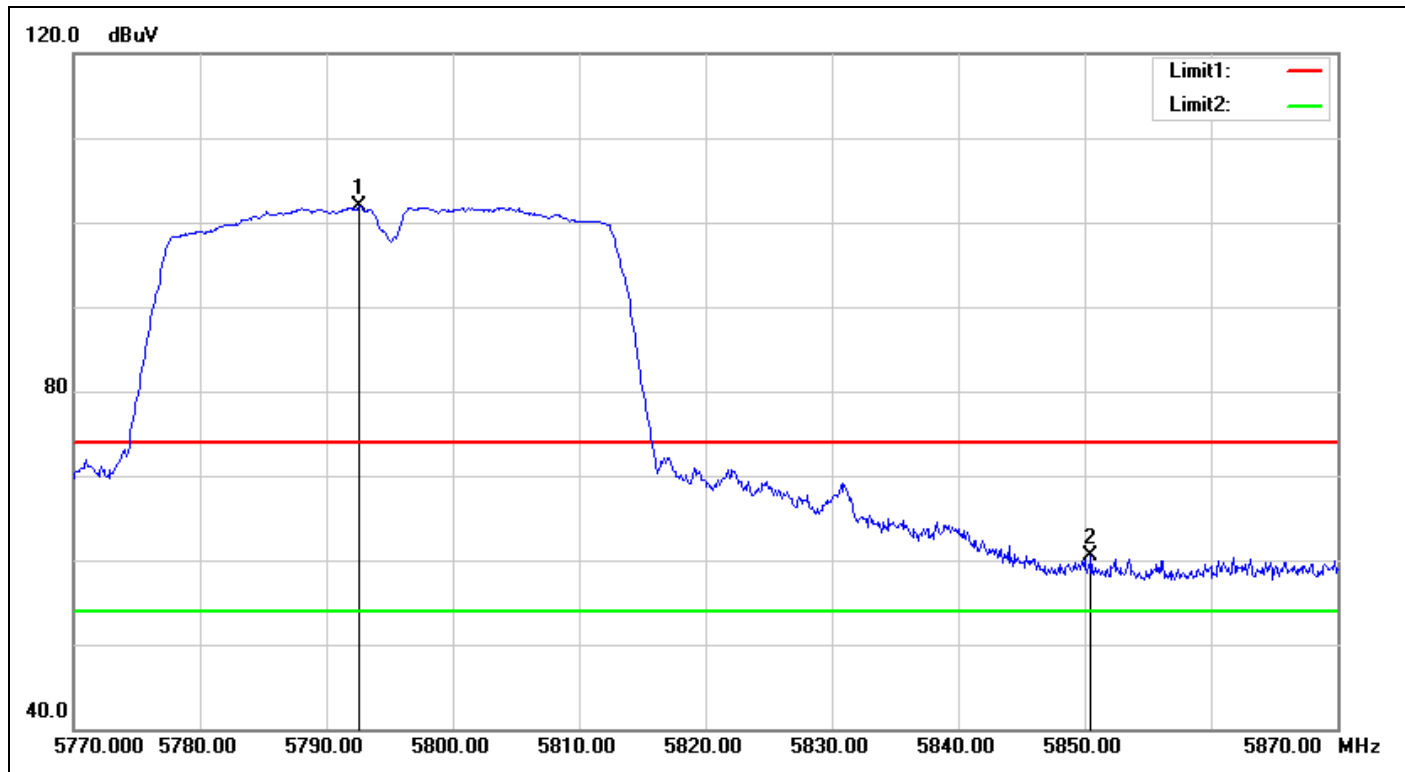

No.	Frequency (MHz)	Reading (dBuV)	Correct Factor(dB)	Result (dBuV)	Limit (dBuV)	Margin (dB)	Remark
1	5792.600	95.39	6.50	101.89	74.00	27.89	peak
2	5850.500	53.77	6.74	60.51	74.00	-13.49	peak

Detector mode: Average

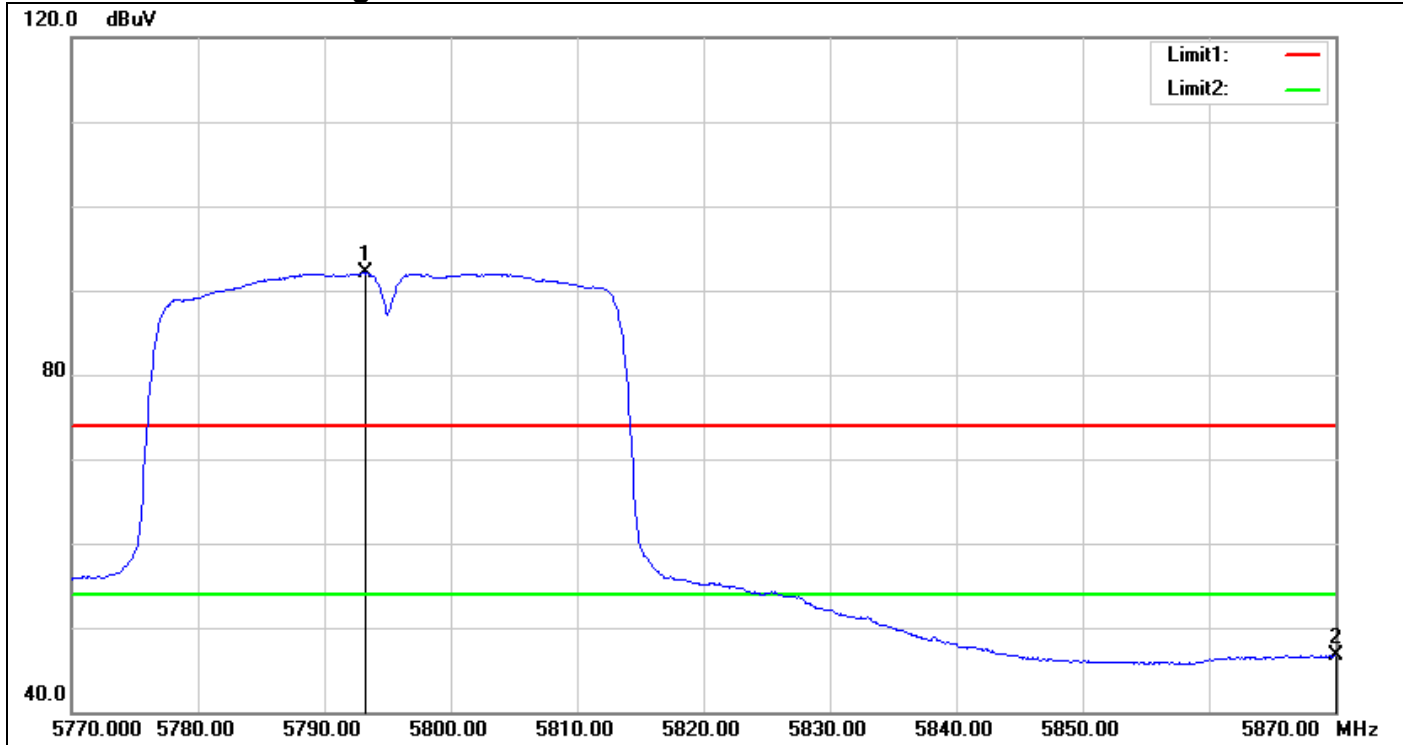

No.	Frequency (MHz)	Reading (dBuV)	Correct Factor(dB)	Result (dBuV)	Limit (dBuV)	Margin (dB)	Remark
1	5793.200	85.52	6.50	92.02	54.00	38.02	AVG
2	5870.000	39.95	6.83	46.78	54.00	-7.22	AVG

7.5 PEAK POWER SPECTRAL DENSITY

LIMIT

1. According to §15.407 & RSS-247 §, for digitally modulated systems, the power spectral density conducted from the intentional radiator to the antenna shall not be greater than 30 dBm in any 500 kHz band during any time interval of continuous transmission.

Test Configuration

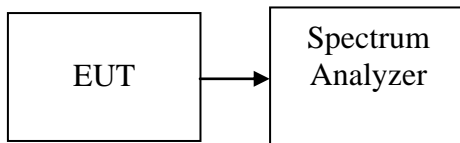

TEST PROCEDURE

1. Place the EUT on the table and set it in transmitting mode. Remove the antenna from the EUT and then connect a low loss RF cable from the antenna port to the spectrum analyzer.
2. Set the spectrum analyzer as RBW = 3kHz, VBW = 10kHz, Span = 300kHz, Sweep=100s
3. Record the max. reading.
4. Repeat the above procedure until the measurements for all frequencies are completed.

TEST RESULTS

No non-compliance noted

Test Data

Test mode: IEEE 802.11a mode/ 5745 ~ 5825MHz

Channel	Frequency (MHz)	PPSD (dBm)	Limit (dBm)	Result
Low	5745	8.10	30.00	PASS
Mid	5785	7.80		PASS
High	5825	8.60		PASS

Test mode: IEEE 802.11n HT 20 MHz mode / 5745 ~ 5825MHz

Channel	Frequency (MHz)	PPSD (dBm)	Limit (dBm)	Result
Low	5745	7.45	30.00	PASS
Mid	5785	7.55		PASS
High	5825	8.05		PASS

Test mode: IEEE 802.11n HT 40 MHz mode / 5755 ~ 5795MHz

Channel	Frequency (MHz)	PPSD (dBm)	Limit (dBm)	Result
Low	5755	4.43	30.00	PASS
High	5795	5.05		PASS

Test Plot

IEEE 802.11a MHz mode / 5745 ~ 5825MHz

PPSD (CH Low)

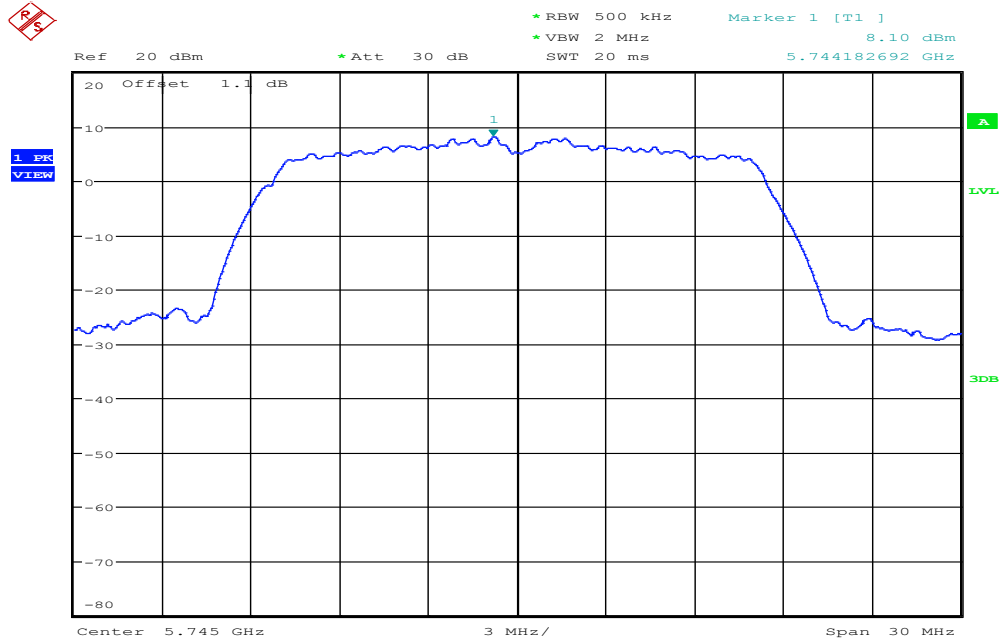

Date: 6.APR.2016 11:54:43

PPSD (CH Mid)

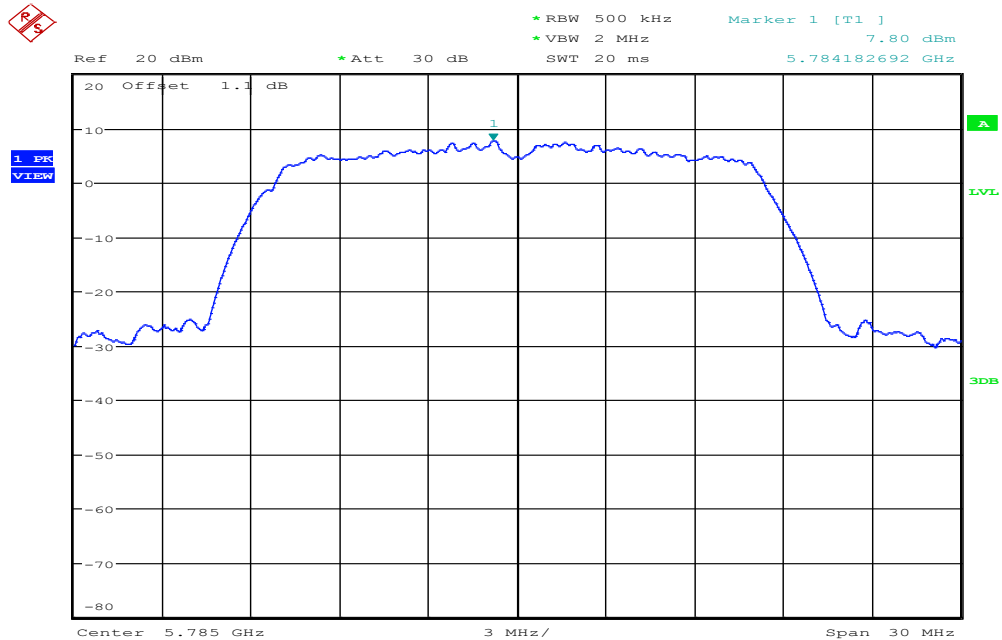

Date: 6.APR.2016 11:55:45

PPSD (CH High)

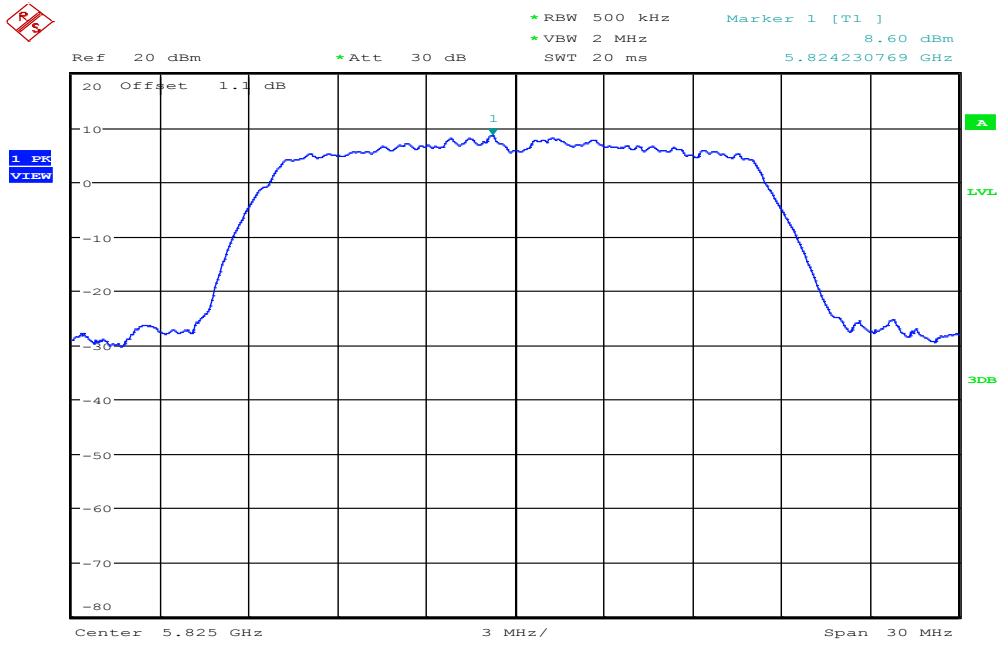

Date: 6.APR.2016 11:56:45

IEEE 802.11n HT 20 MHz mode / 5745 ~ 5825MHz

PPSD (CH Low)

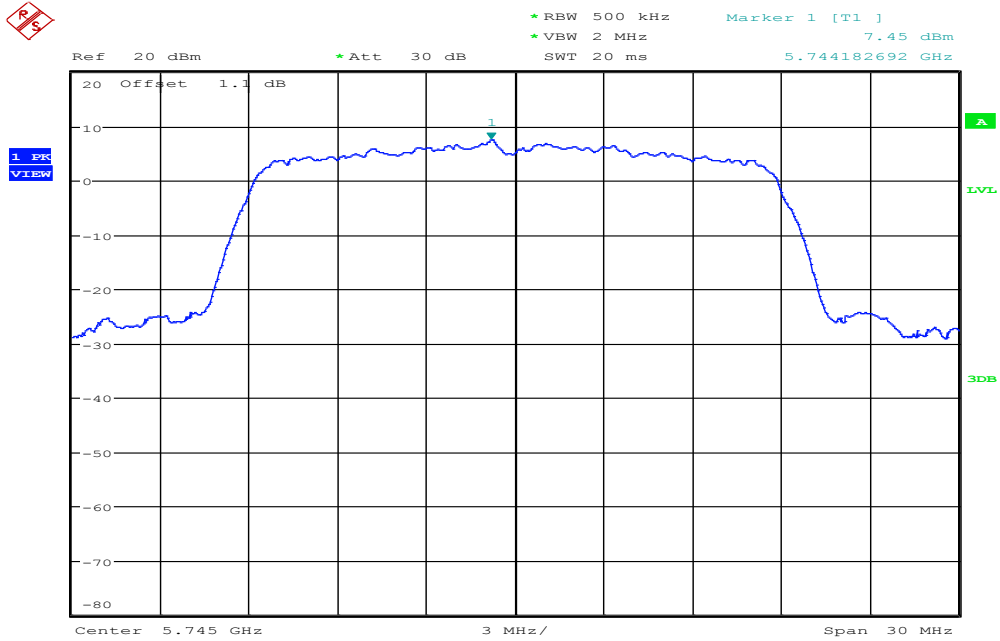

Date: 6.APR.2016 11:58:39

PPSD (CH Mid)

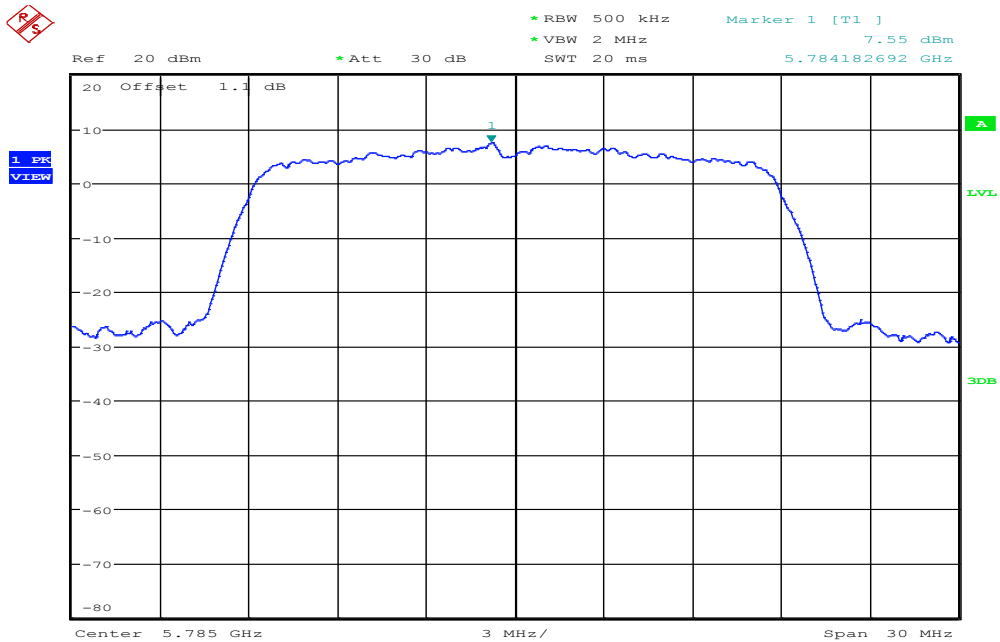

Date: 6.APR.2016 12:00:09

PPSD (CH High)

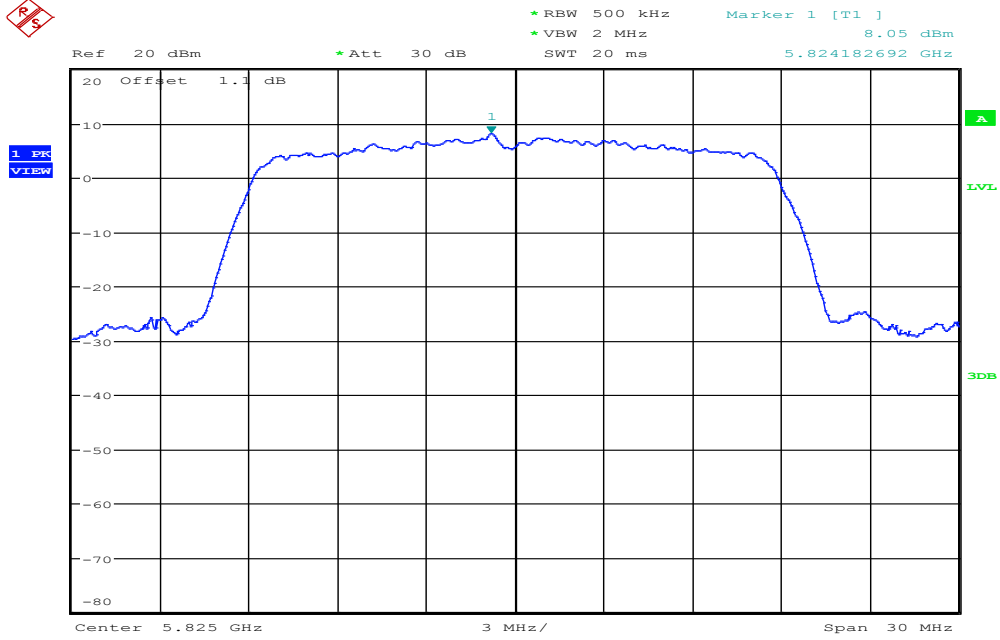

Date: 6.APR.2016 12:01:27

IEEE 802.11n HT 40 MHz mode / 5755 ~ 5795MHz

PPSD (CH Low)

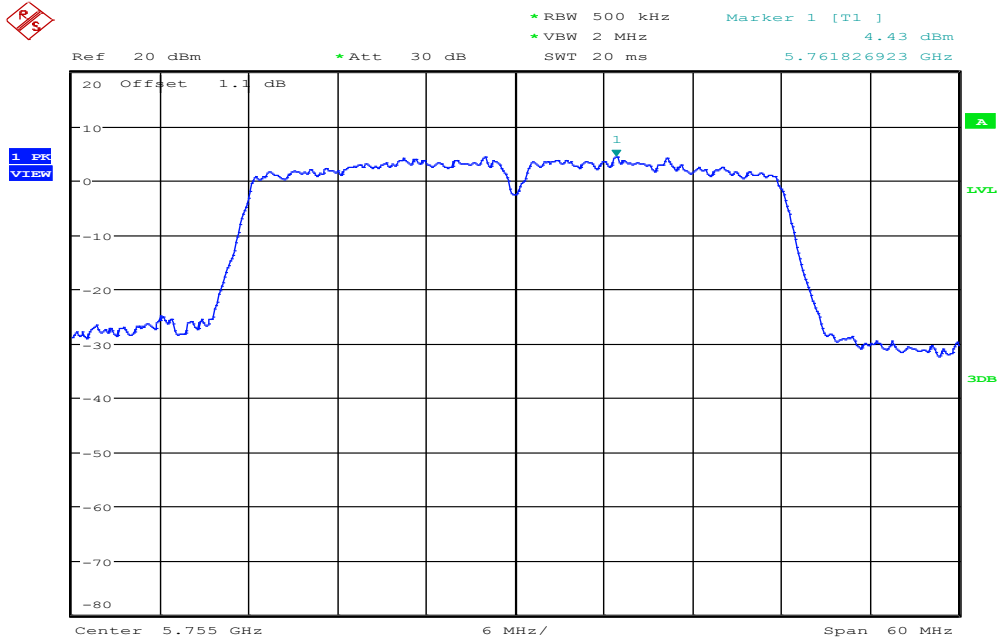

Date: 6.APR.2016 12:39:47

PPSD (CH High)

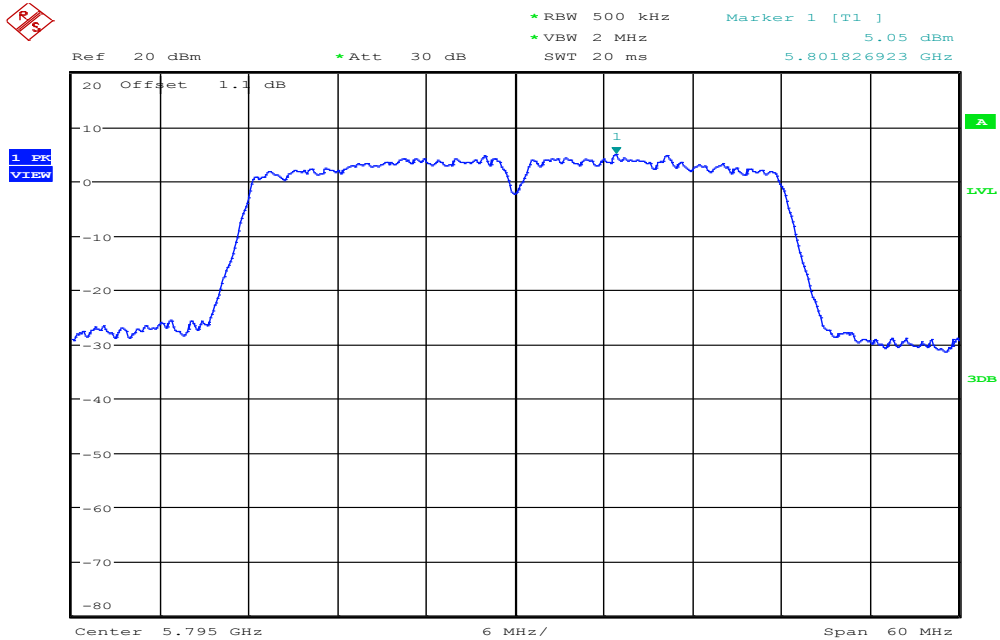

Date: 6.APR.2016 12:42:18

7.6 RADIATED EMISSIONS

LIMIT

All spurious emissions shall comply with the limits of §15.209(a) and RSS-Gen Table 2 & Table 5.

RSS-Gen Table 2 & Table 5: General Field Strength Limits for Transmitters and Receivers at Frequencies Above 30 MHz ^(Note)

Frequency (MHz)	Field Strength microvolts/m at 3 metres (watts, e.i.r.p.)	
	Transmitters	Receivers
30-88	100 (3 nW)	100 (3 nW)
88-216	150 (6.8 nW)	150 (6.8 nW)
216-960	200 (12 nW)	200 (12 nW)
Above 960	500 (75 nW)	500 (75 nW)

Note: *Measurements for compliance with limits in the above table may be performed at distances other than 3 metres, in accordance with Section 7.2.7.

Transmitting devices are not permitted in Table 1 bands or, unless stated otherwise, in TV bands (54-72 MHz, 76-88 MHz, 174-216 MHz, 470-608 MHz and 614-806 MHz).

RSS-Gen Table 6: General Field Strength Limits for Transmitters at Frequencies Below 30 MHz (Transmit)

Frequency	Field Strength (microvolts/m)	Magnetic H-Field (microamperes/m)	Measurement Distance (metres)
9-490 kHz	2,400/F (F in kHz)	2,400/377F (F in kHz)	3000
490-1,705 kHz	24,000/F (F in kHz)	24,000/377F (F in kHz)	30
1.705-30 MHz	30	N/A	30

Note: The emission limits for the bands 9-90 kHz and 110-490 kHz are based on measurements employing an average detector.

Test Configuration

9kHz ~ 30MHz

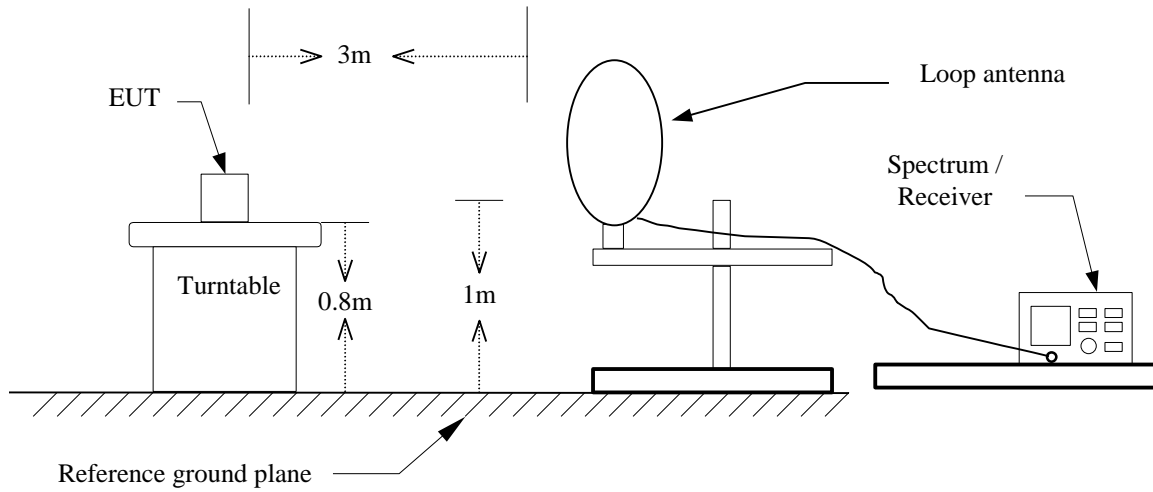

30MHz ~ 1GHz

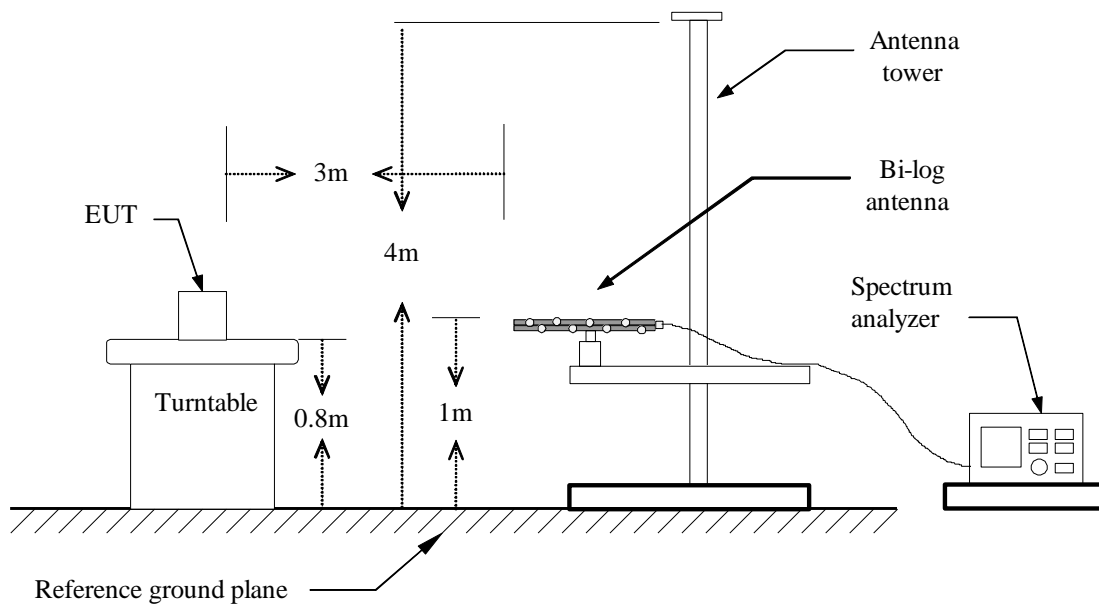

Above 1 GHz

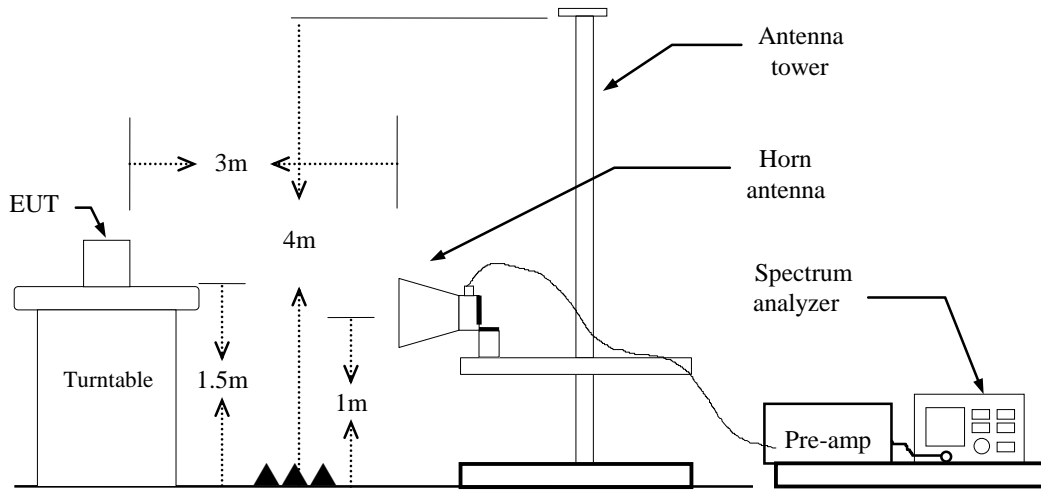

TEST PROCEDURE

1. The EUT is placed on a turntable, Above 1 GHz is 1.5m high and below 1 GHz is 0.8m high above ground plane.
2. The turntable shall be rotated for 360 degrees to determine the position of maximum emission level.
3. EUT is set 3m away from the receiving antenna, which is varied from 1m to 4m to find out the highest emissions.
4. Maximum procedure was performed on the six highest emissions to ensure EUT compliance.
5. And also, each emission was to be maximized by changing the polarization of receiving antenna both horizontal and vertical.
6. Set the spectrum analyzer in the following setting as:

Below 1GHz:

RBW=100kHz / VBW=300kHz / Sweep=AUTO

Above 1GHz:

(a) PEAK: RBW=VBW=1MHz / Sweep=AUTO

(b) AVERAGE: RBW=1MHz,
if duty cycle $\geq 98\%$, VBW=10Hz.
if duty cycle $< 98\%$ VBW=1/T.

IEEE 802.11a mode: $\geq 98\%$, VBW=10Hz

IEEE 802.11n HT 20 MHz mode: $\geq 98\%$, VBW=10Hz

IEEE 802.11n HT 40 MHz mode: $\geq 98\%$, VBW=10Hz

7. Repeat above procedures until the measurements for all frequencies are complete.
8. Result = Spectrum Reading + cable loss(spectrum to Amp) - Amp Gain + Cable loss(Amp to receive Ant)+ Receive Ant

Note: We checked every harmonics frequencies from Fundamental frequencies with reduced VBW, and we mark a point to prove pass or not if we find any emission. For this case, there are no emissions hidden in the noise floor.

Below 1 GHz

Operation Mode: Normal Link

Test Date: April 8, 2016

Temperature: 27°C

Tested by: Jason Lu

Humidity: 53% RH

Polarity: Ver.

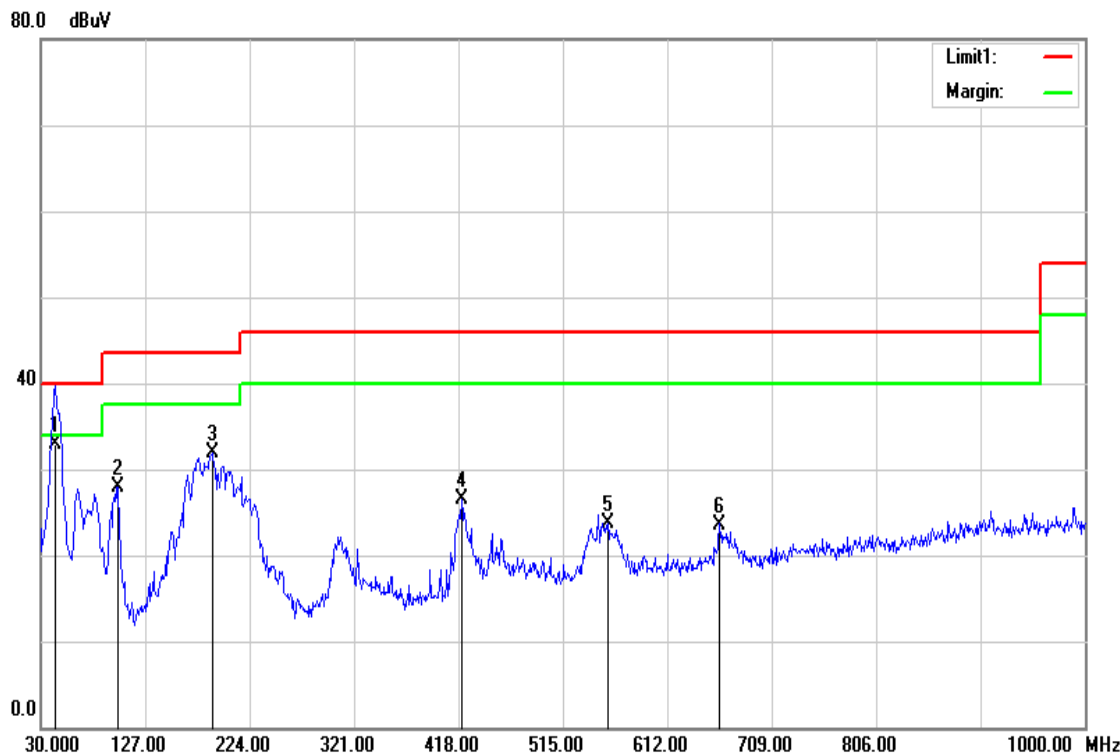

Frequency (MHz)	Reading (dBuV)	Correction Factor (dB/m)	Result (dBuV/m)	Limit (dBuV/m)	Margin (dB)	Remark	Ant.Pol. (H/V)
43.5800	50.21	-17.39	32.82	40.00	-7.18	Peak	V
101.7800	46.61	-18.72	27.89	43.50	-15.61	Peak	V
189.0800	48.48	-16.53	31.95	43.50	-11.55	Peak	V
420.9100	37.48	-11.07	26.41	46.00	-19.59	Peak	V
556.7100	32.05	-8.39	23.66	46.00	-22.34	Peak	V
660.5000	30.06	-6.46	23.60	46.00	-22.40	Peak	V

Remark:

1. No emission found between lowest internal used/generated frequency to 30MHz (9kHz~30MHz).
2. Radiated emissions measured in frequency range from 30 MHz to 1000MHz were made with an instrument using peak/quasi-peak detector mode.
3. Quasi-peak test would be performed if the peak result were greater than the quasi-peak limit or as required by the applicant.
4. Measurements above show only up to 6 maximum emissions noted, or would be lesser, with " N/A " remark, if no specific emissions from the EUT are recorded (ie: margin>20dB from the applicable limit) and considered that's already beyond the background noise floor.
5. Margin (dB) = Remark result (dBuV/m) – Quasi-peak limit (dBuV/m).

Operation Mode: Normal Link

Test Date: April 8, 2016

Temperature: 27°C

Tested by: Jason Lu

Humidity: 53% RH

Polarity: Hor.

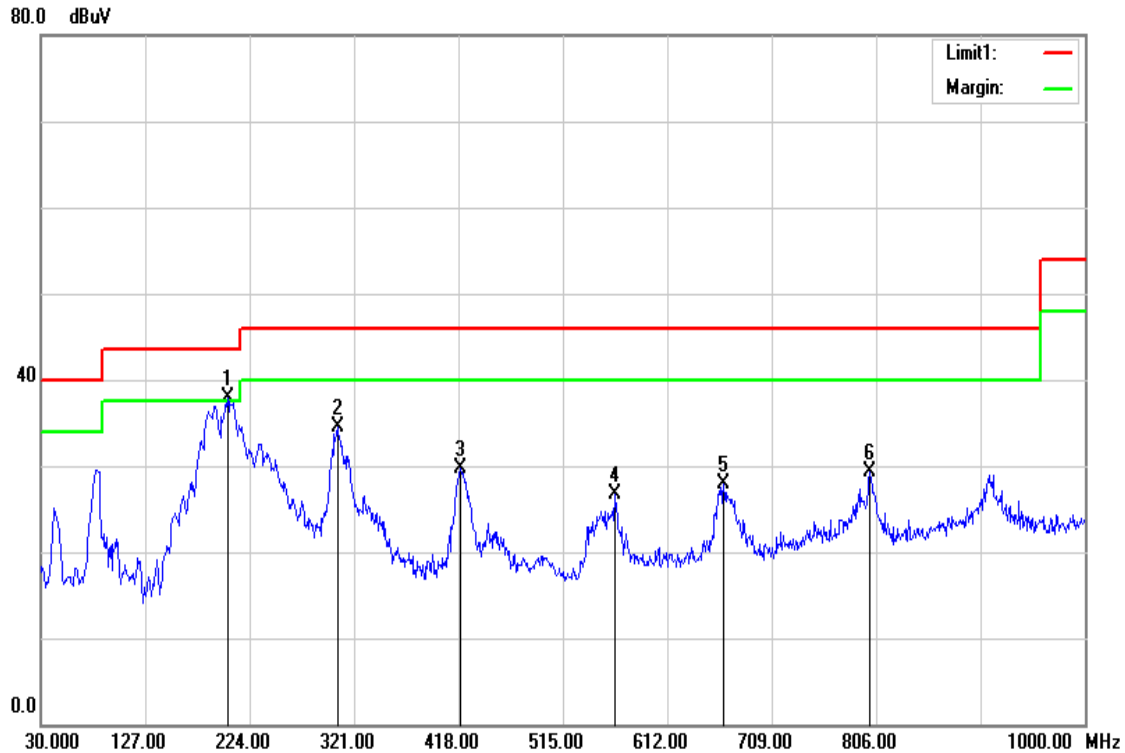

Frequency (MHz)	Reading (dBuV)	Correction Factor (dB/m)	Result (dBuV/m)	Limit (dBuV/m)	Margin (dB)	Remark	Ant.Pol. (H/V)
203.6300	53.73	-15.81	37.92	43.50	-5.58	Peak	H
305.4800	48.61	-14.09	34.52	46.00	-11.48	Peak	H
419.9400	40.86	-11.10	29.76	46.00	-16.24	Peak	H
563.5000	34.90	-8.29	26.61	46.00	-19.39	Peak	H
664.3800	34.26	-6.43	27.83	46.00	-18.17	Peak	H
800.1800	33.75	-4.50	29.25	46.00	-16.75	Peak	H

Remark:

1. No emission found between lowest internal used/generated frequency to 30MHz (9kHz~30MHz).
2. Radiated emissions measured in frequency range from 30 MHz to 1000MHz were made with an instrument using peak/quasi-peak detector mode.
3. Quasi-peak test would be performed if the peak result were greater than the quasi-peak limit or as required by the applicant.
4. Measurements above show only up to 6 maximum emissions noted, or would be lesser, with " N/A " remark, if no specific emissions from the EUT are recorded (ie: margin>20dB from the applicable limit) and considered that's already beyond the background noise floor.
5. Margin (dB) = Remark result (dBuV/m) – Quasi-peak limit (dBuV/m).

Above 1 GHz

TX / IEEE 802.11a mode / CH Low

Polarity: Vertical

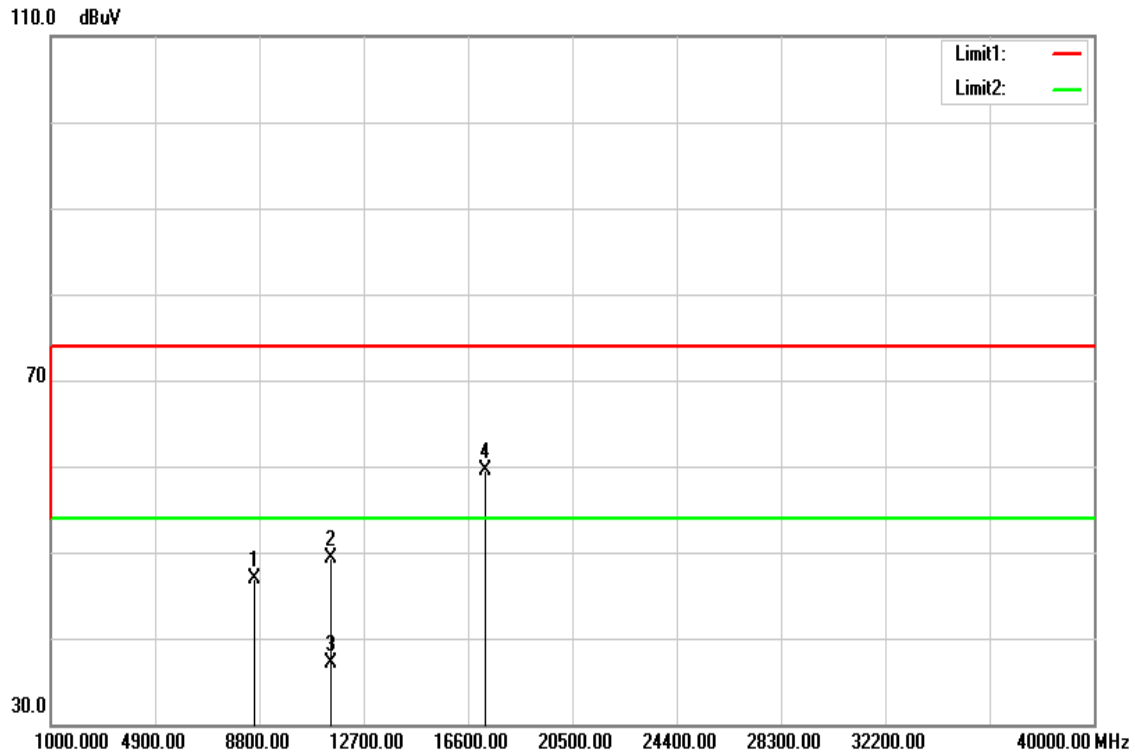

Polarity: Horizontal

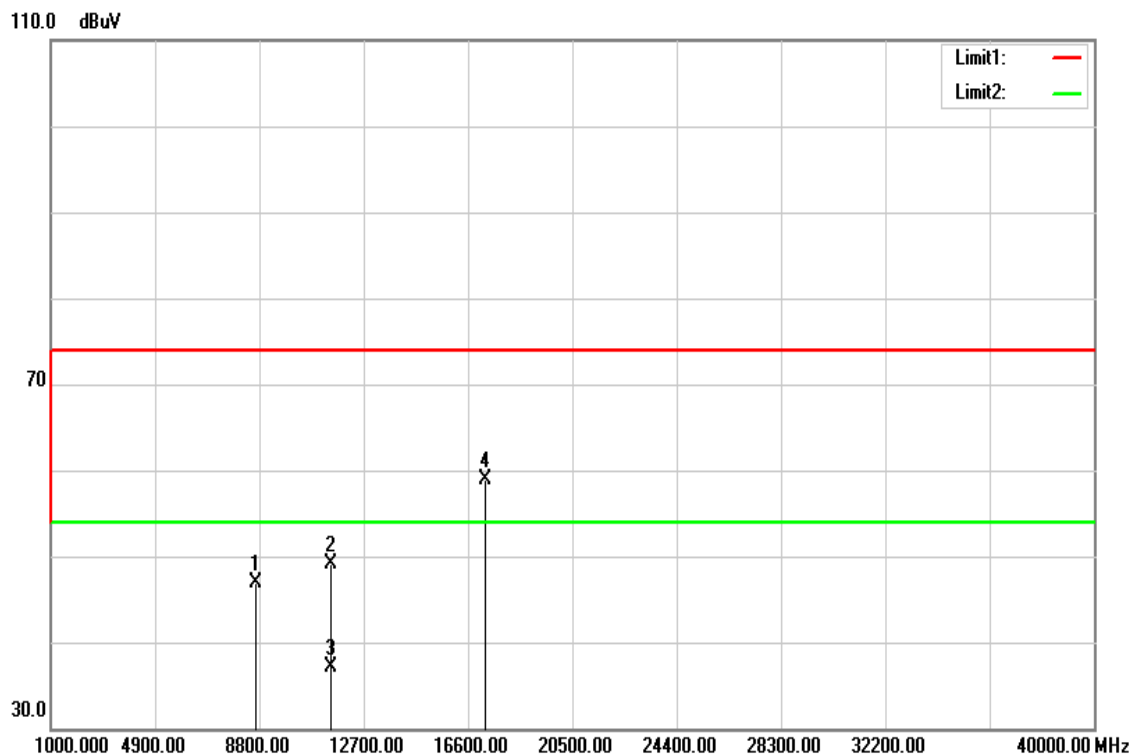

Operation Mode: TX / IEEE 802.11a mode / CH Low **Test Date:** April 13, 2016
Temperature: 27°C **Tested by:** Jason Lu
Humidity: 53% RH **Polarity:** Ver. / Hor.

Frequency (MHz)	Reading (dBuV)	Correction (dB/m)	Result (dBuV/m)	Limit (dBuV/m)	Margin (dB)	Remark	Ant.Pol. (H/V)
8629.000	33.23	13.70	46.93	74.00	-27.07	peak	V
11490.000	32.50	16.78	49.28	74.00	-24.72	peak	V
11490.000	20.38	16.78	37.16	54.00	-16.84	AVG	V
17235.000	34.30	25.28	59.58	74.00	-14.42	peak	V
N/A							
8649.000	33.28	13.71	46.99	74.00	-27.01	peak	H
11490.000	32.36	16.78	49.14	74.00	-24.86	peak	H
11490.000	20.27	16.78	37.05	54.00	-16.95	AVG	H
17235.000	33.57	25.28	58.85	74.00	-15.15	peak	H
N/A							

Remark:

1. Measuring frequencies from 1 GHz to the 10th harmonic of highest fundamental frequency.
2. Radiated emissions measured in frequency above 1000MHz were made with an instrument using peak/average detector mode.
3. Average test would be performed if the peak result were greater than the average limit.
4. Data of measurement within this frequency range shown " --- " in the table above means the reading of emissions are attenuated more than 20dB below the permissible limits or the field strength is too small to be measured.
5. Measurements above show only up to 6 maximum emissions noted, or would be lesser, with " N/A " remark, if no specific emissions from the EUT are recorded (ie: margin>20dB from the applicable limit) and considered that's already beyond the background noise floor.
6. Margin (dB) = Remark result (dBuV/m) – Average limit (dBuV/m).

TX / IEEE 802.11a mode / CH Mid

Polarity: Vertical

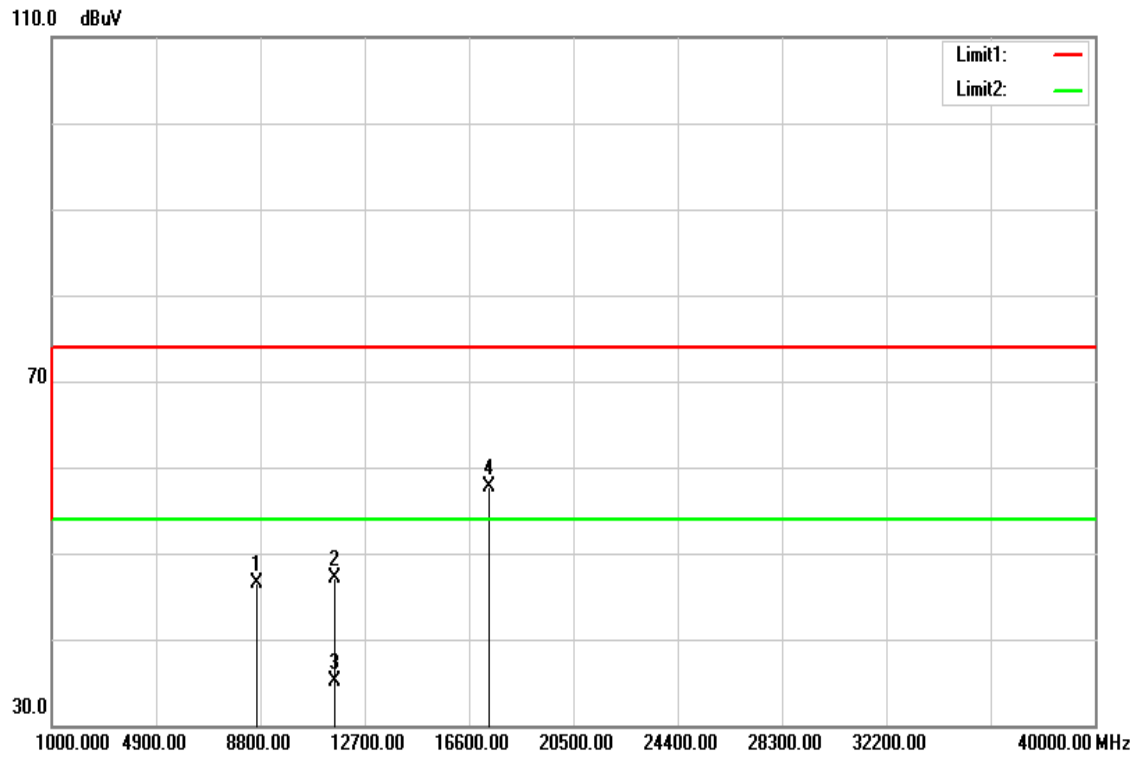

Polarity: Horizontal

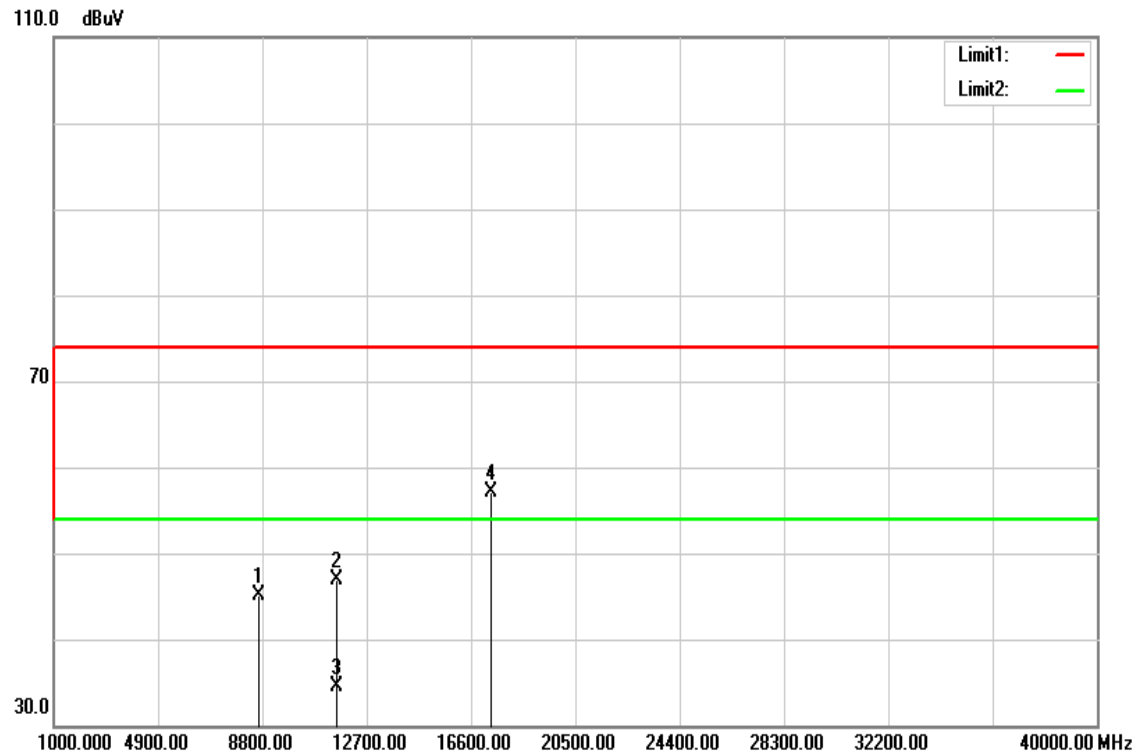

Operation Mode: TX / IEEE 802.11a mode / CH Mid **Test Date:** April 13, 2016
Temperature: 27°C **Tested by:** Jason Lu
Humidity: 53% RH **Polarity:** Ver. / Hor.

Frequency (MHz)	Reading (dBuV)	Correction (dB/m)	Result (dBuV/m)	Limit (dBuV/m)	Margin (dB)	Remark	Ant.Pol. (H/V)
8677.000	32.75	13.72	46.47	74.00	-27.53	peak	V
11570.000	30.20	16.84	47.04	74.00	-26.96	peak	V
11570.000	18.17	16.84	35.01	54.00	-18.99	AVG	V
17355.000	31.95	25.75	57.70	74.00	-16.30	peak	V
N/A							
8666.000	31.42	13.72	45.14	74.00	-28.86	peak	H
11570.000	30.06	16.84	46.90	74.00	-27.10	peak	H
11570.000	17.73	16.84	34.57	54.00	-19.43	AVG	H
17355.000	31.33	25.75	57.08	74.00	-16.92	peak	H
N/A							

Remark:

1. *Measuring frequencies from 1 GHz to the 10th harmonic of highest fundamental frequency.*
2. *Radiated emissions measured in frequency above 1000MHz were made with an instrument using peak/average detector mode.*
3. *Average test would be performed if the peak result were greater than the average limit.*
4. *Data of measurement within this frequency range shown “ --- ” in the table above means the reading of emissions are attenuated more than 20dB below the permissible limits or the field strength is too small to be measured.*
5. *Measurements above show only up to 6 maximum emissions noted, or would be lesser, with “ N/A ” remark, if no specific emissions from the EUT are recorded (ie: margin>20dB from the applicable limit) and considered that's already beyond the background noise floor.*
6. *Margin (dB) = Remark result (dBuV/m) – Average limit (dBuV/m).*

TX / IEEE 802.11a mode / CH High

Polarity: Vertical

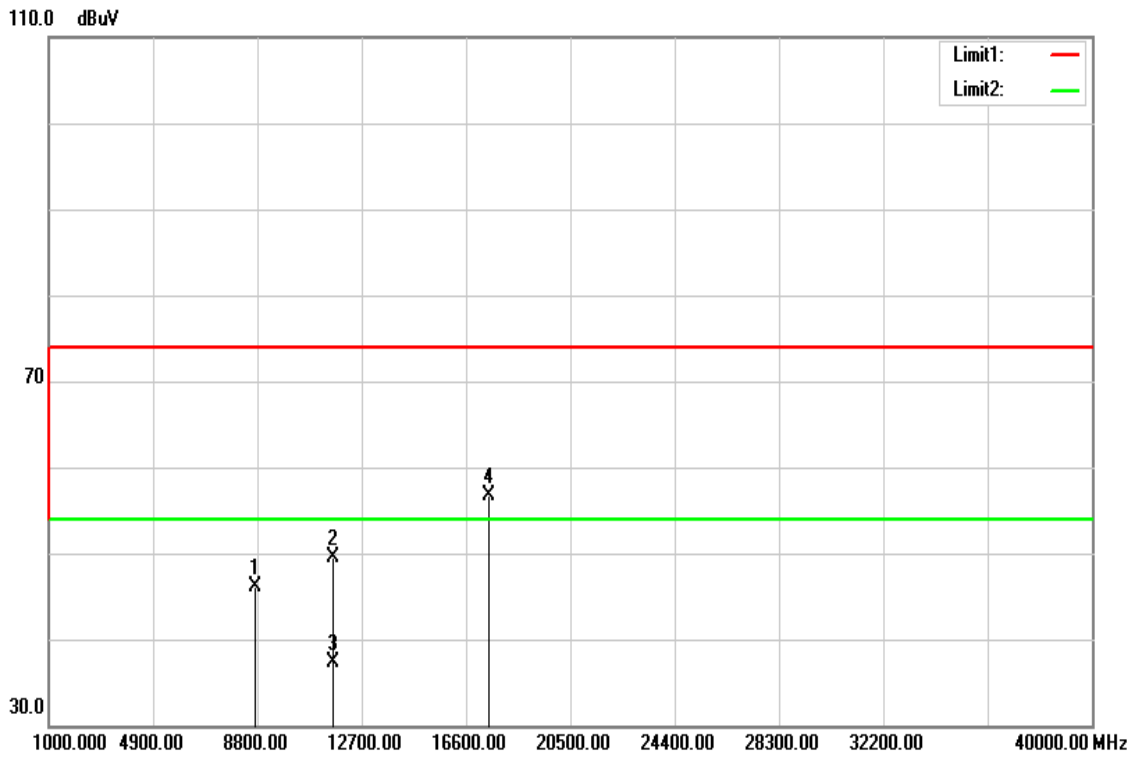

Polarity: Horizontal

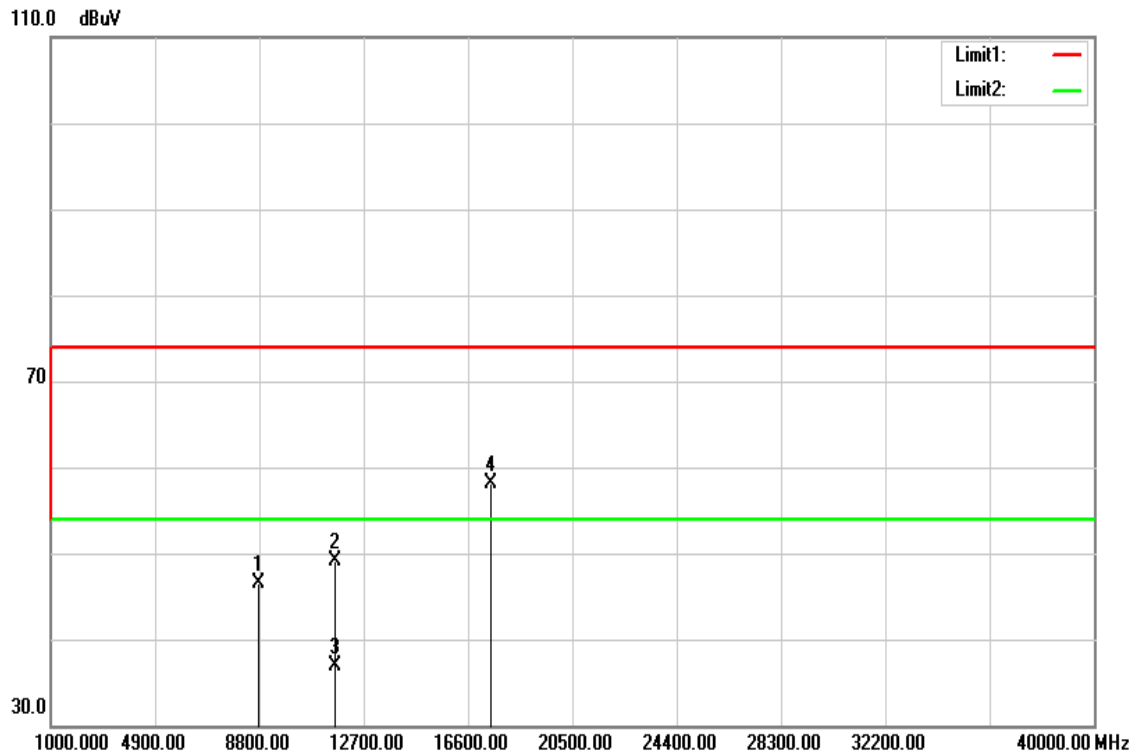

Operation Mode: TX / IEEE 802.11a mode / CH High **Test Date:** April 13, 2016
Temperature: 27°C **Tested by:** Jason Lu
Humidity: 53% RH **Polarity:** Ver. / Hor.

Frequency (MHz)	Reading (dBuV)	Correction (dB/m)	Result (dBuV/m)	Limit (dBuV/m)	Margin (dB)	Remark	Ant.Pol. (H/V)
8723.000	32.28	13.74	46.02	74.00	-27.98	peak	V
11650.000	32.56	16.91	49.47	74.00	-24.53	peak	V
11650.000	20.42	16.91	37.33	54.00	-16.67	AVG	V
17475.000	30.57	26.22	56.79	74.00	-17.21	peak	V
N/A							
8754.000	32.73	13.76	46.49	74.00	-27.51	peak	H
11650.000	32.14	16.91	49.05	74.00	-24.95	peak	H
11650.000	20.04	16.91	36.95	54.00	-17.05	AVG	H
17475.000	31.97	26.22	58.19	74.00	-15.81	peak	H
N/A							

Remark:

1. *Measuring frequencies from 1 GHz to the 10th harmonic of highest fundamental frequency.*
2. *Radiated emissions measured in frequency above 1000MHz were made with an instrument using peak/average detector mode.*
3. *Average test would be performed if the peak result were greater than the average limit.*
4. *Data of measurement within this frequency range shown “ --- ” in the table above means the reading of emissions are attenuated more than 20dB below the permissible limits or the field strength is too small to be measured.*
5. *Measurements above show only up to 6 maximum emissions noted, or would be lesser, with “ N/A ” remark, if no specific emissions from the EUT are recorded (ie: margin>20dB from the applicable limit) and considered that's already beyond the background noise floor.*
6. *Margin (dB) = Remark result (dBuV/m) – Average limit (dBuV/m).*

TX / IEEE 802.11n HT 20 MHz mode / CH Low

Polarity: Vertical

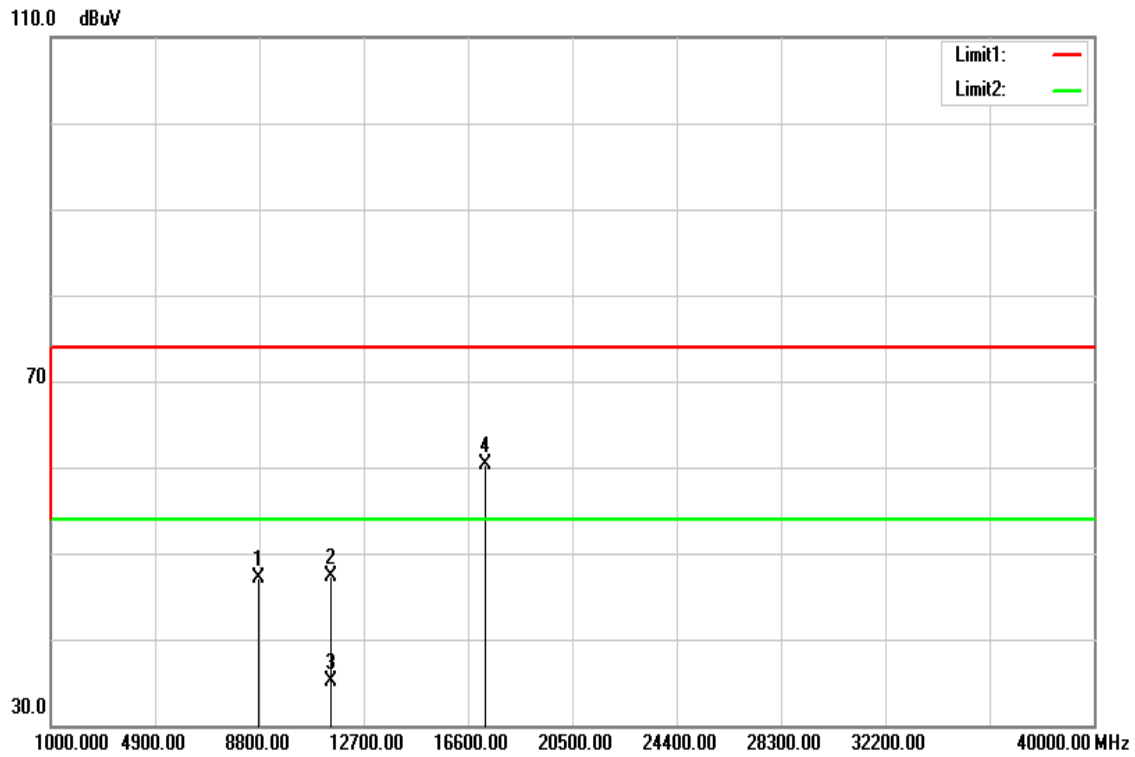

Polarity: Horizontal

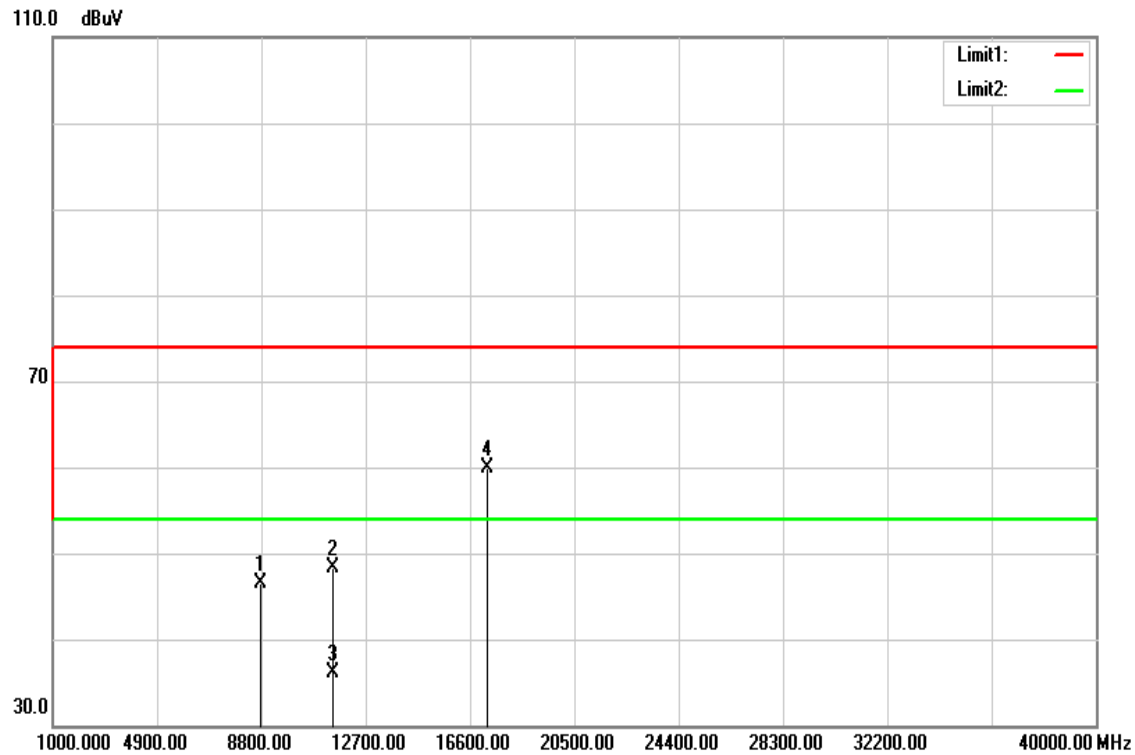

Operation Mode: TX / IEEE 802.11n HT 20 MHz mode / CH Low **Test Date:** April 13, 2016
Temperature: 27°C **Tested by:** Jason Lu
Humidity: 53% RH **Polarity:** Ver. / Hor.

Frequency (MHz)	Reading (dBuV)	Correction (dB/m)	Result (dBuV/m)	Limit (dBuV/m)	Margin (dB)	Remark	Ant.Pol. (H/V)
8756.000	33.43	13.76	47.19	74.00	-26.81	peak	V
11490.000	30.57	16.78	47.35	74.00	-26.65	peak	V
11490.000	18.38	16.78	35.16	54.00	-18.84	AVG	V
17235.000	35.03	25.28	60.31	74.00	-13.69	peak	V
N/A							
8759.000	32.80	13.76	46.56	74.00	-27.44	peak	H
11490.000	31.49	16.78	48.27	74.00	-25.73	peak	H
11490.000	19.24	16.78	36.02	54.00	-17.98	AVG	H
17235.000	34.62	25.28	59.90	74.00	-14.10	peak	H
N/A							

Remark:

1. Measuring frequencies from 1 GHz to the 10th harmonic of highest fundamental frequency.
2. Radiated emissions measured in frequency above 1000MHz were made with an instrument using peak/average detector mode.
3. Average test would be performed if the peak result were greater than the average limit or as required by the applicant.
4. Data of measurement within this frequency range shown " --- " in the table above means the reading of emissions are attenuated more than 20dB below the permissible limits or the field strength is too small to be measured.
5. Measurements above show only up to 6 maximum emissions noted, or would be lesser, with " N/A " remark, if no specific emissions from the EUT are recorded (ie: margin>20dB from the applicable limit) and considered that's already beyond the background noise floor.
6. Margin (dB) = Remark result (dBuV/m) – Average limit (dBuV/m).

TX / IEEE 802.11n HT 20 MHz mode / CH Mid

Polarity: Vertical

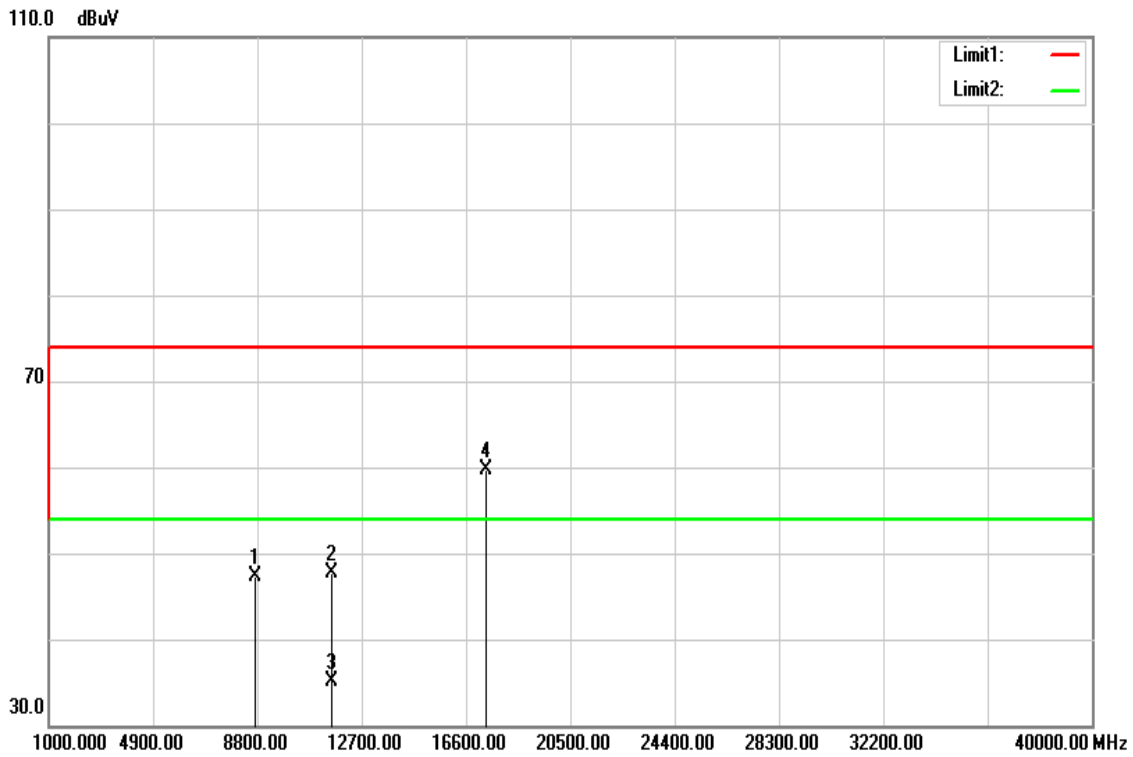

Polarity: Horizontal

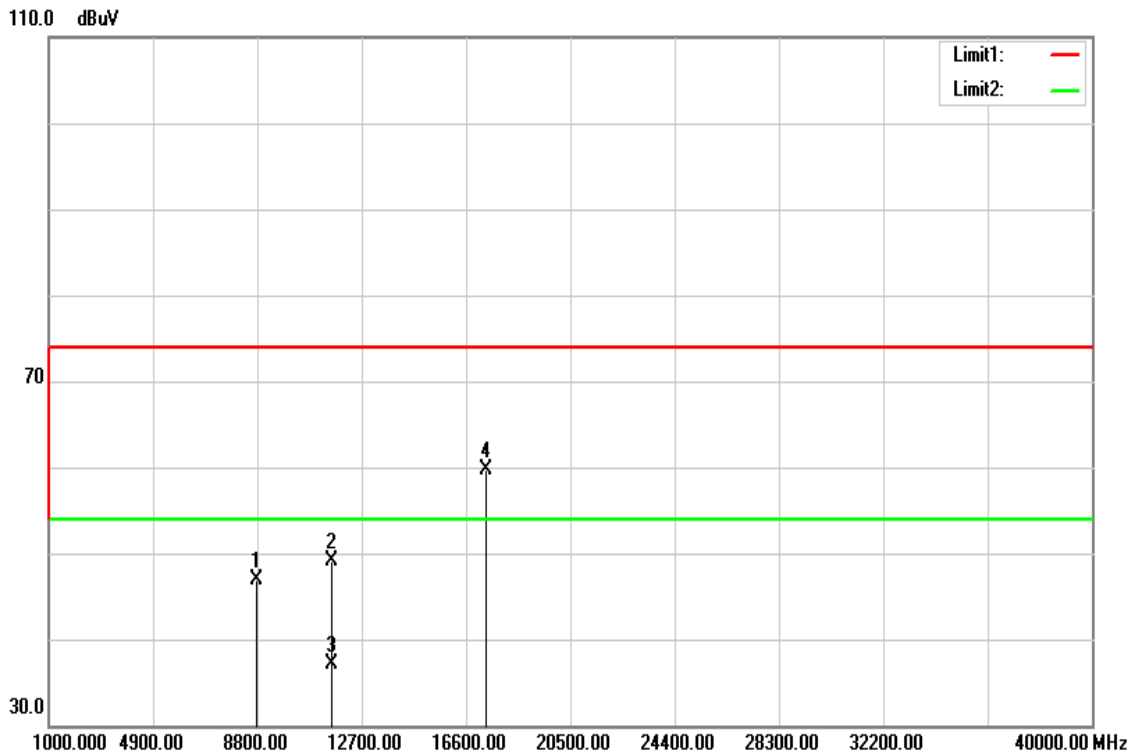

Operation Mode: TX / IEEE 802.11n HT 20 MHz mode / CH Mid

Test Date: April 13, 2016

Temperature: 27°C

Tested by: Jason Lu

Humidity: 53% RH

Polarity: Ver. / Hor.

Frequency (MHz)	Reading (dBuV)	Correction (dB/m)	Result (dBuV/m)	Limit (dBuV/m)	Margin (dB)	Remark	Ant.Pol. (H/V)
8698.000	33.65	13.73	47.38	74.00	-26.62	peak	V
11570.000	30.91	16.84	47.75	74.00	-26.25	peak	V
11570.000	18.27	16.84	35.11	54.00	-18.89	AVG	V
17355.000	33.93	25.75	59.68	74.00	-14.32	peak	V
N/A							
8759.000	33.17	13.76	46.93	74.00	-27.07	peak	H
11570.000	32.26	16.84	49.10	74.00	-24.90	peak	H
11570.000	20.21	16.84	37.05	54.00	-16.95	AVG	H
17355.000	33.94	25.75	59.69	74.00	-14.31	peak	H
N/A							

Remark:

1. Measuring frequencies from 1 GHz to the 10th harmonic of highest fundamental frequency.
2. Radiated emissions measured in frequency above 1000MHz were made with an instrument using peak/average detector mode.
3. Average test would be performed if the peak result were greater than the average limit or as required by the applicant.
4. Data of measurement within this frequency range shown " --- " in the table above means the reading of emissions are attenuated more than 20dB below the permissible limits or the field strength is too small to be measured.
5. Measurements above show only up to 6 maximum emissions noted, or would be lesser, with " N/A " remark, if no specific emissions from the EUT are recorded (ie: margin>20dB from the applicable limit) and considered that's already beyond the background noise floor.
6. Margin (dB) = Remark result (dBuV/m) – Average limit (dBuV/m).

TX / IEEE 802.11n HT 20 MHz mode / CH High

Polarity: Vertical

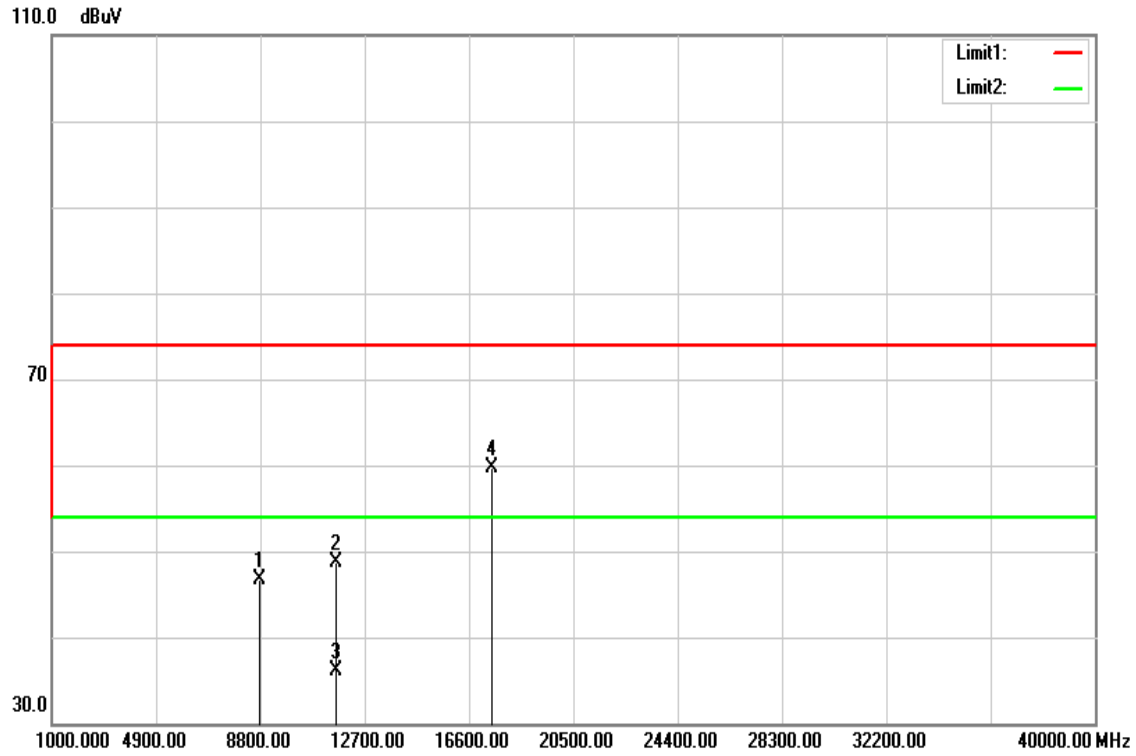

Polarity: Horizontal

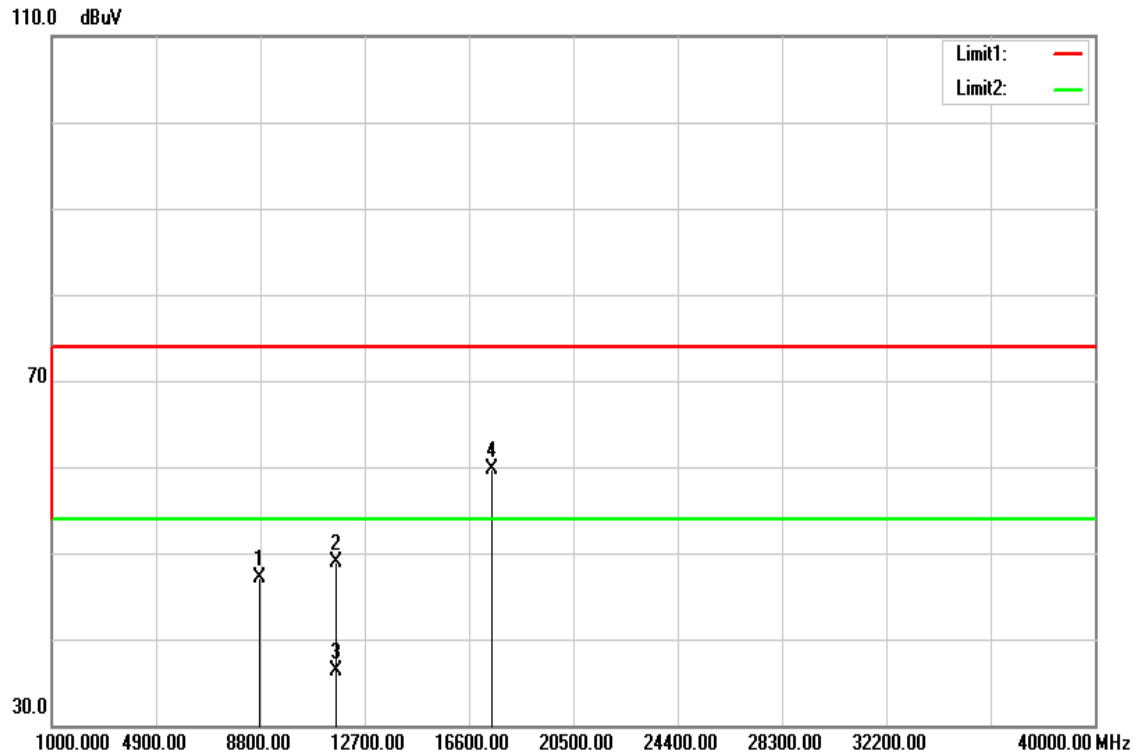

Operation Mode: TX / IEEE 802.11n HT 20 MHz mode / CH High **Test Date:** April 13, 2016
Temperature: 27°C **Tested by:** Jason Lu
Humidity: 53% RH **Polarity:** Ver. / Hor.

Frequency (MHz)	Reading (dBuV)	Correction (dB/m)	Result (dBuV/m)	Limit (dBuV/m)	Margin (dB)	Remark	Ant.Pol. (H/V)
8759.000	32.99	13.76	46.75	74.00	-27.25	peak	V
11650.000	31.74	16.91	48.65	74.00	-25.35	peak	V
11650.000	19.10	16.91	36.01	54.00	-17.99	AVG	V
17475.000	33.52	26.22	59.74	74.00	-14.26	peak	V
N/A							
8795.000	33.37	13.78	47.15	74.00	-26.85	peak	H
11650.000	31.95	16.91	48.86	74.00	-25.14	peak	H
11650.000	19.34	16.91	36.25	54.00	-17.75	AVG	H
17475.000	33.51	26.22	59.73	74.00	-14.27	peak	H
N/A							

Remark:

1. Measuring frequencies from 1 GHz to the 10th harmonic of highest fundamental frequency.
2. Radiated emissions measured in frequency above 1000MHz were made with an instrument using peak/average detector mode.
3. Average test would be performed if the peak result were greater than the average limit or as required by the applicant.
4. Data of measurement within this frequency range shown " --- " in the table above means the reading of emissions are attenuated more than 20dB below the permissible limits or the field strength is too small to be measured.
5. Measurements above show only up to 6 maximum emissions noted, or would be lesser, with " N/A " remark, if no specific emissions from the EUT are recorded (ie: margin>20dB from the applicable limit) and considered that's already beyond the background noise floor.
6. Margin (dB) = Remark result (dBuV/m) – Average limit (dBuV/m).

TX / IEEE 802.11n HT 40 MHz mode / CH Low

Polarity: Vertical

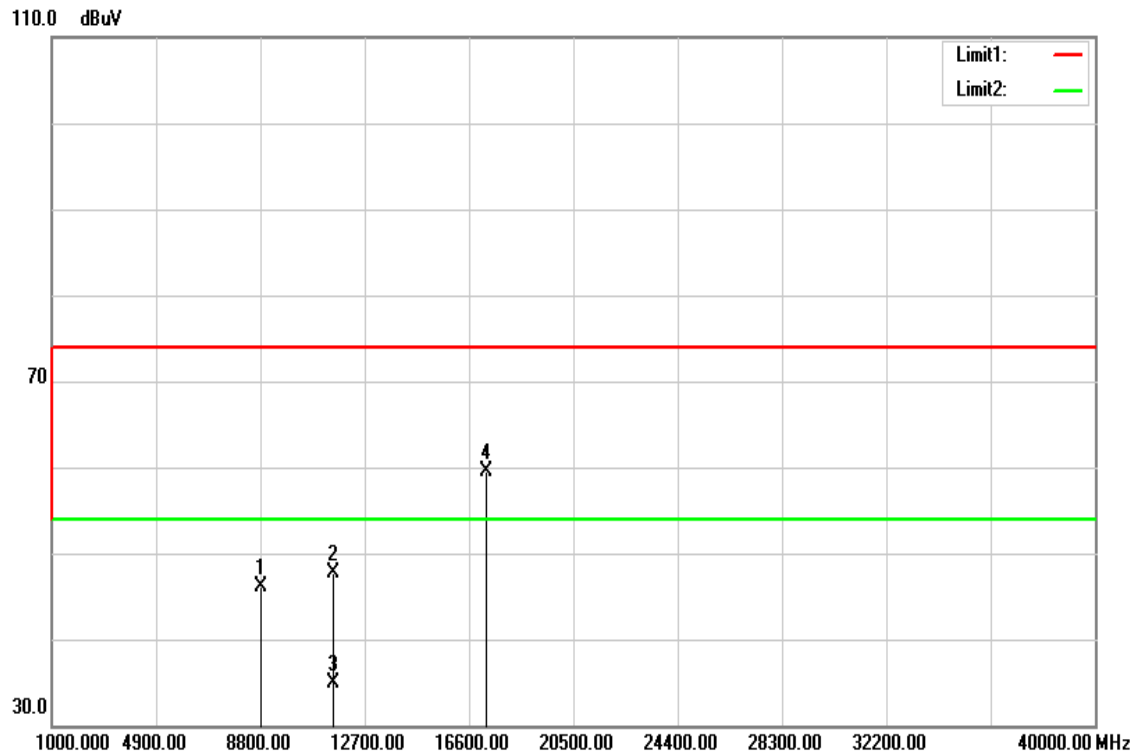

Polarity: Horizontal

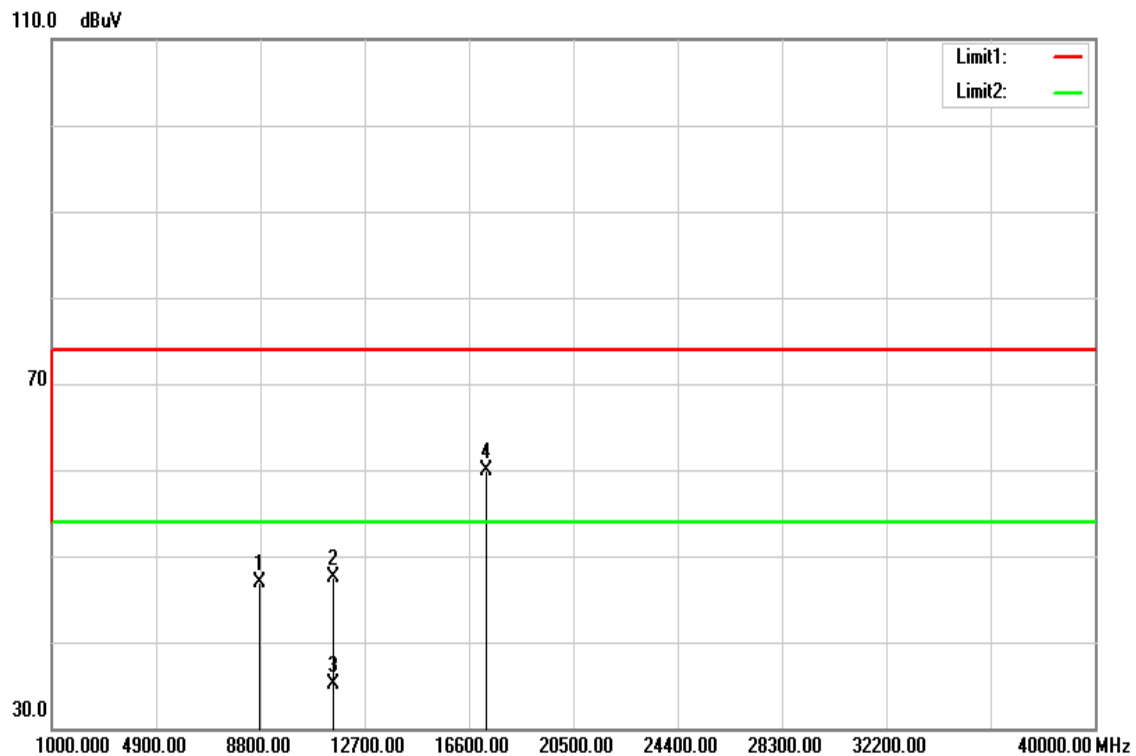

Operation Mode: TX / IEEE 802.11n HT 40 MHz mode
/ CH Low

Test Date: April 14, 2016

Temperature: 27°C

Tested by: Jason Lu

Humidity: 53% RH

Polarity: Ver. / Hor.

Frequency (MHz)	Reading (dBuV)	Correction (dB/m)	Result (dBuV/m)	Limit (dBuV/m)	Margin (dB)	Remark	Ant.Pol. (H/V)
8851.000	32.37	13.80	46.17	74.00	-27.83	peak	V
11510.000	30.97	16.79	47.76	74.00	-26.24	peak	V
11510.000	18.17	16.79	34.96	54.00	-19.04	AVG	V
17265.000	34.06	25.40	59.46	74.00	-14.54	peak	V
N/A							
8799.000	33.14	13.78	46.92	74.00	-27.08	peak	H
11510.000	30.77	16.79	47.56	74.00	-26.44	peak	H
11510.000	18.37	16.79	35.16	54.00	-18.84	AVG	H
17265.000	34.49	25.40	59.89	74.00	-14.11	peak	H
N/A							

Remark:

1. Measuring frequencies from 1 GHz to the 10th harmonic of highest fundamental frequency.
2. Radiated emissions measured in frequency above 1000MHz were made with an instrument using peak/average detector mode.
3. Average test would be performed if the peak result were greater than the average limit or as required by the applicant.
4. Data of measurement within this frequency range shown " --- " in the table above means the reading of emissions are attenuated more than 20dB below the permissible limits or the field strength is too small to be measured.
5. Measurements above show only up to 6 maximum emissions noted, or would be lesser, with " N/A " remark, if no specific emissions from the EUT are recorded (ie: margin>20dB from the applicable limit) and considered that's already beyond the background noise floor.
6. Margin (dB) = Remark result (dBuV/m) – Average limit (dBuV/m).

TX / IEEE 802.11n HT 40 MHz mode / CH High

Polarity: Vertical

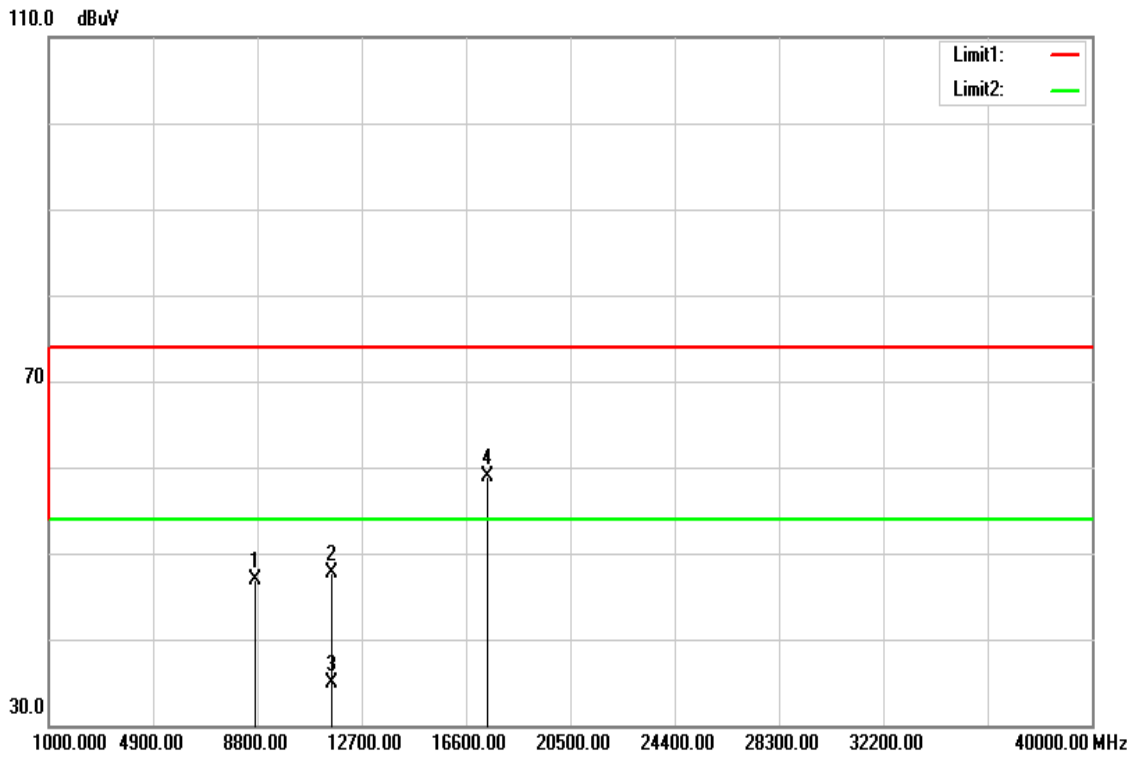

Polarity: Horizontal

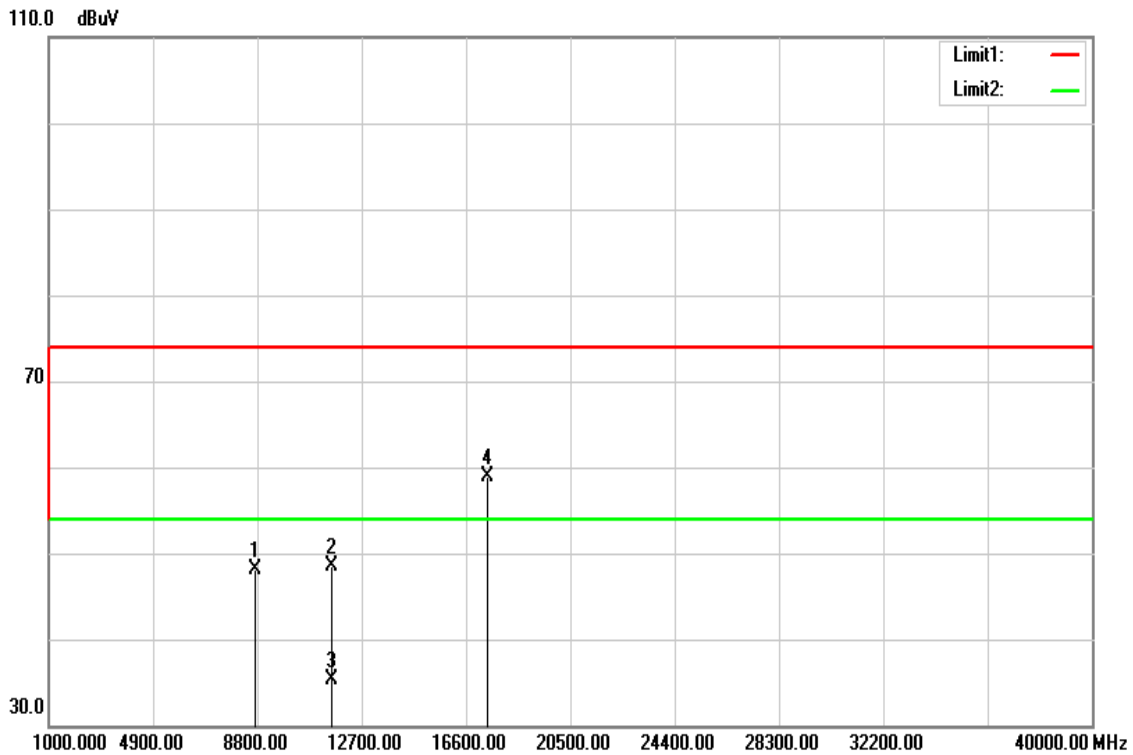

Operation Mode: TX / IEEE 802.11n HT 40 MHz mode / CH High

Test Date: April 14, 2016

Temperature: 27°C

Tested by: Jason Lu

Humidity: 53% RH

Polarity: Ver. / Hor.

Frequency (MHz)	Reading (dBuV)	Correction (dB/m)	Result (dBuV/m)	Limit (dBuV/m)	Margin (dB)	Remark	Ant.Pol. (H/V)
8711.000	33.09	13.74	46.83	74.00	-27.17	peak	V
11590.000	30.84	16.86	47.70	74.00	-26.30	peak	V
11590.000	18.06	16.86	34.92	54.00	-19.08	AVG	V
17385.000	33.10	25.87	58.97	74.00	-15.03	peak	V
N/A							
8722.000	34.36	13.74	48.10	74.00	-25.90	peak	H
11590.000	31.61	16.86	48.47	74.00	-25.53	peak	H
11590.000	18.43	16.86	35.29	54.00	-18.71	AVG	H
17385.000	32.99	25.87	58.86	74.00	-15.14	peak	H
N/A							

Remark:

1. Measuring frequencies from 1 GHz to the 10th harmonic of highest fundamental frequency.
2. Radiated emissions measured in frequency above 1000MHz were made with an instrument using peak/average detector mode.
3. Average test would be performed if the peak result were greater than the average limit or as required by the applicant.
4. Data of measurement within this frequency range shown " --- " in the table above means the reading of emissions are attenuated more than 20dB below the permissible limits or the field strength is too small to be measured.
5. Measurements above show only up to 6 maximum emissions noted, or would be lesser, with " N/A " remark, if no specific emissions from the EUT are recorded (ie: margin>20dB from the applicable limit) and considered that's already beyond the background noise floor.
6. Margin (dB) = Remark result (dBuV/m) – Average limit (dBuV/m).

7.7 POWERLINE CONDUCTED EMISSIONS

LIMIT

According to §15.207(a) & RSS-Gen §7.2.4, except when the requirements applicable to a given device state otherwise, for any licence-exempt radiocommunication device equipped to operate from the public utility AC power supply, either directly or indirectly, the radio frequency voltage that is conducted back onto the AC power lines in the frequency range of 0.15 MHz to 30 MHz shall not exceed the limits shown in Table 2. The tighter limit applies at the frequency range boundaries.

The conducted emissions shall be measured with a 50 ohm/50 microhenry line impedance stabilization network.

RSS-Gen Table 2 – AC Power Lines Conducted Emission Limits

Frequency Range (MHz)	Conducted limit (dBµV)	
	Quasi-peak	Average
0.15 to 0.5	66 to 56*	56 to 46*
0.5 to 5	56	46
5 to 30	60	50

**Decreases with the logarithm of the frequency*

Test Configuration

See test photographs attached in Appendix 1 for the actual connections between EUT and support equipment.

TEST PROCEDURE

1. The EUT was placed on a table, which is 0.8m above ground plane.
2. Maximum procedure was performed on the six highest emissions to ensure EUT compliance.
3. Repeat above procedures until all frequency measured were complete.

TEST RESULTS

The initial step in collecting conducted data is a spectrum analyzer peak scan of the measurement range. Significant peaks are then marked as shown on the following data page, and these signals are then quasi-peaked.

Test Data

Operation Mode: Normal Link **Test Date:** April 12, 2016
Temperature: 24°C **Tested by:** Jason Lu
Humidity: 56% RH

Freq. (MHz)	QP Reading (dBuV)	AV Reading (dBuV)	Corr. factor (dB/m)	QP Result (dBuV/m)	AV Result (dBuV/m)	QP Limit (dBuV)	AV Limit (dBuV)	QP Margin (dB)	AV Margin (dB)	Note
0.1700	45.91	34.09	9.77	55.68	43.86	64.96	54.96	-9.28	-11.10	L1
0.1900	44.31	34.05	9.76	54.07	43.81	64.04	54.04	-9.97	-10.23	L1
0.2100	42.15	29.13	9.76	51.91	38.89	63.21	53.21	-11.30	-14.32	L1
0.2340	37.82	24.41	9.76	47.58	34.17	62.31	52.31	-14.73	-18.14	L1
0.3060	35.12	23.43	9.77	44.89	33.20	60.08	50.08	-15.19	-16.88	L1
0.4660	25.44	12.31	9.86	35.30	22.17	56.58	46.58	-21.28	-24.41	L1
0.5380	24.96	14.84	9.96	34.92	24.80	56.00	46.00	-21.08	-21.20	L1
15.1420	25.38	16.63	10.11	35.49	26.74	60.00	50.00	-24.51	-23.26	L1
0.1620	47.18	35.26	9.84	57.02	45.10	65.36	55.36	-8.34	-10.26	L2
0.1700	46.90	36.31	9.84	56.74	46.15	64.96	54.96	-8.22	-8.81	L2
0.1940	46.41	35.04	9.83	56.24	44.87	63.86	53.86	-7.62	-8.99	L2
0.2100	45.16	31.37	9.83	54.99	41.20	63.20	53.21	-8.21	-12.01	L2
0.2380	39.55	25.50	9.83	49.38	35.33	62.16	52.17	-12.78	-16.84	L2
0.2660	39.25	26.22	9.83	49.08	36.05	61.24	51.24	-12.16	-15.19	L2
0.2779	37.23	25.34	9.83	47.06	35.17	60.88	50.88	-13.82	-15.71	L2
0.3060	37.79	24.17	9.83	47.62	34.00	60.08	50.08	-12.46	-16.08	L2
0.4740	29.11	19.43	9.93	39.04	29.36	56.44	46.44	-17.40	-17.08	L2
0.5220	30.41	19.28	10.00	40.41	29.28	56.00	46.00	-15.59	-16.72	L2
0.6100	27.67	15.15	10.12	37.79	25.27	56.00	46.00	-18.21	-20.73	L2

Remark:

1. Measuring frequencies from 0.15 MHz to 30MHz.
2. The emissions measured in frequency range from 0.15 MHz to 30MHz were made with an instrument using Quasi-peak detector and average detector.
3. The IF bandwidth of SPA between 0.15MHz to 30MHz was 10kHz; the IF bandwidth of Test Receiver between 0.15MHz to 30MHz was 9kHz;
4. L1 = Line One (Live Line) / L2 = Line Two (Neutral Line)

Test Plots

Conducted emissions (Line 1)

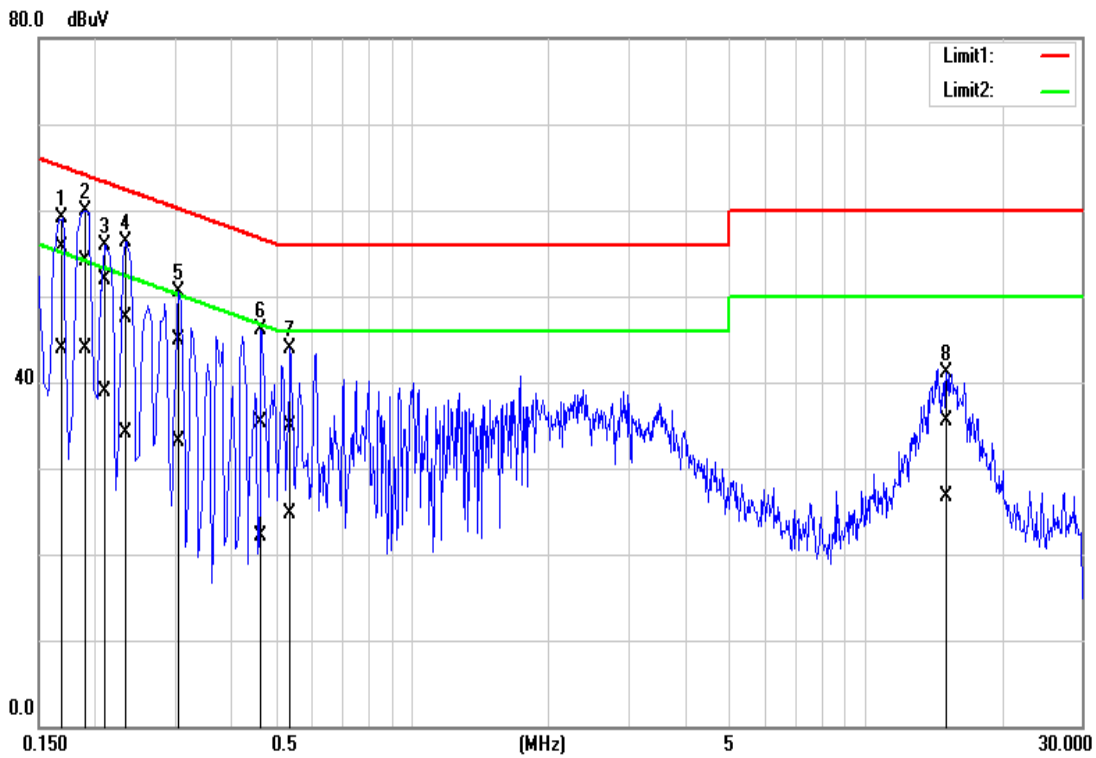

Conducted emissions (Line 2)

