

**FCC 47 CFR PART 15 SUBPART E &
INDUSTRY CANADA RSS-247**

TEST REPORT

For

Tablet Computer

Model: A6002

Trade Name: acer

Issued to

Acer Incorporated

8F, 88, Sec 1, Xintai 5th Rd. Xizhi, New Taipei City 221 Taiwan, R.O.C

Issued by

Compliance Certification Services Inc.

**No.11, Wugong 6th Rd., Wugu Dist.,
New Taipei City 24891, Taiwan. (R.O.C.)**

<http://www.ccsrf.com>

service@ccsrf.com

Issued Date: April 20, 2016



Note: This report shall not be reproduced except in full, without the written approval of Compliance Certification Services Inc. This document may be altered or revised by Compliance Certification Services Inc. personnel only, and shall be noted in the revision section of the document.

Revision History

Rev.	Issue Date	Revisions	Effect Page	Revised By
00	April 20, 2016	Initial Issue	ALL	Doris Chu

TABLE OF CONTENTS

1. TEST RESULT CERTIFICATION	4
2. EUT DESCRIPTION.....	5
3. TEST METHODOLOGY.....	7
3.1 EUT CONFIGURATION.....	7
3.2 EUT EXERCISE.....	7
3.3 GENERAL TEST PROCEDURES.....	7
3.4 FCC PART 15.205 RESTRICTED BANDS OF OPERATIONS	8
3.5 DESCRIPTION OF TEST MODES.....	9
4. INSTRUMENT CALIBRATION	11
4.1 MEASURING INSTRUMENT CALIBRATION.....	11
4.2 MEASUREMENT EQUIPMENT USED.....	11
4.3 MEASUREMENT UNCERTAINTY.....	12
5. FACILITIES AND ACCREDITATIONS.....	13
5.1 FACILITIES.....	13
5.2 EQUIPMENT.....	13
5.3 LABORATORY ACCREDITATIONS AND LISTING.....	13
5.4 TABLE OF ACCREDITATIONS AND LISTINGS.....	14
6. SETUP OF EQUIPMENT UNDER TEST	15
6.1 SETUP CONFIGURATION OF EUT	15
6.2 SUPPORT EQUIPMENT	15
7. FCC PART 15 REQUIREMENTS & RSS-247 REQUIREMENTS.....	16
7.1 99% BANDWIDTH	16
7.2 26 DB EMISSION BANDWIDTH	36
7.3 MAXIMUM CONDUCTED OUTPUT POWER.....	56
7.4 BAND EDGES MEASUREMENT.....	60
7.5 PEAK POWER SPECTRAL DENSITY.....	112
7.6 RADIATED UNDESIRABLE EMISSION	132
7.7 POWERLINE CONDUCTED EMISSIONS.....	188
7.8 FREQUENCY STABILITY.....	191
7.9 DYNAMIC FREQUENCY SELECTION.....	193
APPENDIX I PHOTOGRAPHS OF TEST SETUP.....	221

1. TEST RESULT CERTIFICATION

Applicant: Acer Incorporated
8F, 88, Sec 1, Xintai 5th Rd. Xizhi, New Taipei City 221 Taiwan,
R.O.C

Manufacturer: Acer Incorporated
8F, 88, Sec 1, Xintai 5th Rd. Xizhi, New Taipei City 221 Taiwan,
R.O.C

Equipment Under Test: Tablet Computer

Model Number: A6002

Trade Name: acer

Date of Test: April 1 ~ 14, 2016

APPLICABLE STANDARDS	
STANDARD	TEST RESULT
FCC 47 CFR Part 15 Subpart E & Industry Canada RSS-247 Issue 1	No non-compliance noted

We hereby certify that:

Compliance Certification Services Inc. tested the above equipment. The test data, data evaluation, test procedures, and equipment configurations shown in this report were made in accordance with the procedures given in ANSI C63.10: 2013 and the energy emitted by the sample EUT tested as described in this report is in compliance with conducted and radiated emission limits of FCC Rules Part 15.407 and Industry Canada RSS-247 Issue 1.

The test results of this report relate only to the tested sample identified in this report.

Approved by:



Miller Lee
Manager
Compliance Certification Services Inc.

Reviewed by:



Angel Cheng
Section Manager
Compliance Certification Services Inc.

2. EUT DESCRIPTION

Product	Tablet Computer				
Model Number	A6002				
Trade Name	acer				
Received Date	March 29, 2016				
Power Supply	1.VDC from Power Adapter 2. Power from Battery 3. Powered from host device via USB				
Operating Frequency Range & Number of Channels		Mode	Frequency Range (MHz)	Number of Channels	
	U-NII-1	IEEE 802.11a	5180 ~ 5240	4 Channels	
		IEEE 802.11n HT 20 MHz	5180 ~ 5240	4 Channels	
		IEEE 802.11n HT 40 MHz	5190 ~ 5230	2 Channels	
	U-NII-2A	IEEE 802.11a	5260 ~ 5320	4 Channels	
		IEEE 802.11n HT 20 MHz	5260 ~ 5320	4 Channels	
		IEEE 802.11n HT 40 MHz	5270 ~ 5310	2 Channels	
	U-NII-2C	IEEE 802.11a	5500 ~ 5700	11 Channels	
		IEEE 802.11n HT 20 MHz	5500 ~ 5700	11 Channels	
		IEEE 802.11n HT 40 MHz	5510 ~ 5670	5 Channels	
Transmit Power		Mode	Frequency Range (MHz)	Output Power (dBm)	Output Power (w)
	U-NII-1	IEEE 802.11a	5180 ~ 5240	13.49	0.0223
		IEEE 802.11n HT 20 MHz	5180 ~ 5240	13.17	0.0207
		IEEE 802.11n HT 40 MHz	5190 ~ 5230	13.28	0.0213
	U-NII-2A	IEEE 802.11a	5260 ~ 5320	13.46	0.0222
		IEEE 802.11n HT 20 MHz	5260 ~ 5320	13.37	0.0217
		IEEE 802.11n HT 40 MHz	5270 ~ 5310	13.48	0.0223
	U-NII-2C	IEEE 802.11a	5500 ~ 5700	13.38	0.0218
		IEEE 802.11n HT 20 MHz	5500 ~ 5700	13.28	0.0213
		IEEE 802.11n HT 40 MHz	5510 ~ 5670	13.33	0.0215
Modulation Technique	OFDM (64QAM, 16QAM, QPSK, BPSK)				
Antenna Specification	Model: A10H FPC Antenna / Gain: 3.9dBi				

Remark: 1. The sample selected for test was engineering sample that approximated to production product and was provided by manufacturer.

2. *Keypast List :*

Components	Vendor	Model Name or Key Spec.	
EMMC(FLASH)	Hynix	H26M52103FMR	16G
	Sandisk	SDIN9DS2	32G
CPU	MTK	MT8163V/A	64-bit Quad Cortex A53
DDR3L	Hynix	H5TC4G83CFR-PBA	2GB (512*8*4)
M/B	Sun & lynn	A10H_V1.1	94V-0
LCD Panel	Kingdisplay	KD101N51-34NP-A1 19	-
Battery	TCL	D279594NR01 (1S2P)	3.7V
Front Camera module	microkore	W05P4021 V2	GC2355
Rear Camera module	microkore	W05P4021 V2	OV5670
Speaker left	Haosheng	XHS160911WW30P30-02-RH	4Ω
Speaker right	Haosheng	XHS160911WW30P30-06-RH	4Ω
Adapter	Liteon	PA-1100-25 Rating: Input: 100~240V, 50/60Hz , 0.3A Output: 5.2V, 2A	
	Delta	ADP-10HW A Rating: Input: 100~240V, 50/60Hz , 0.4A Output: 5.35V, 2A	

3. TEST METHODOLOGY

The tests documented in this report were performed in accordance with ANSI C63.10: 2013 and FCC CFR 47 Part 15.207, 15.209, 15.407, KDB 644545 D03 v01 and KDB 789033 D02 v01r01 General UNII Test Procedures New Rules v01r01.

The tests documented in this report were performed in accordance with IC RSS-247, IC RSS-Gen and ANSI C63.10:2013.

This submittal(s) (test report) is intended for IC Certification with Industry Canada RSS-247.

3.1 EUT CONFIGURATION

The EUT configuration for testing is installed for RF field strength measurement to meet the Commissions requirement, and is operated in a manner intended to generate the maximum emission in a continuous normal application.

3.2 EUT EXERCISE

The EUT is operated in the engineering mode to fix the Tx frequency for the purposes of measurement.

According to its specifications, the EUT must comply with the requirements of Section 15.407 under the FCC Rules Part 15 Subpart E.

3.3 GENERAL TEST PROCEDURES

Conducted Emissions

According to the requirements in ANSI C63.10: 2013, the conducted emission from the EUT is measured in the frequency range between 0.15 MHz and 30MHz, using the CISPR Quasi-Peak detector mode.

Radiated Emissions

The EUT is placed on the turntable, which is 1.5 m above the ground plane. The turntable is then rotated for 360 degrees to determine the proper orientation for the maximum emission level. The EUT is set 3m away from the receiving antenna, which is varied from 1m to 4m to find out the highest emission level. And, each emission is to be maximized by changing the horizontal and vertical polarization of the receiving antenna. In order to find out the maximum emissions, exploratory radiated emission measurements were made according to the requirements in ANSI C63.10: 2013.

3.4 FCC PART 15.205 RESTRICTED BANDS OF OPERATIONS

(a) Except as shown in paragraph (d) of this section, only spurious emissions are permitted in any of the frequency bands listed below:

MHz	MHz	MHz	GHz
0.090 - 0.110	16.42 - 16.423	399.9 - 410	4.5 - 5.15
¹ 0.495 - 0.505	16.69475 - 16.69525	608 - 614	5.35 - 5.46
2.1735 - 2.1905	16.80425 - 16.80475	960 - 1240	7.25 - 7.75
4.125 - 4.128	25.5 - 25.67	1300 - 1427	8.025 - 8.5
4.17725 - 4.17775	37.5 - 38.25	1435 - 1626.5	9.0 - 9.2
4.20725 - 4.20775	73 - 74.6	1645.5 - 1646.5	9.3 - 9.5
6.215 - 6.218	74.8 - 75.2	1660 - 1710	10.6 - 12.7
6.26775 - 6.26825	108 - 121.94	1718.8 - 1722.2	13.25 - 13.4
6.31175 - 6.31225	123 - 138	2200 - 2300	14.47 - 14.5
8.291 - 8.294	149.9 - 150.05	2310 - 2390	15.35 - 16.2
8.362 - 8.366	156.52475 -	2483.5 - 2500	17.7 - 21.4
8.37625 - 8.38675	156.52525	2655 - 2900	22.01 - 23.12
8.41425 - 8.41475	156.7 - 156.9	3260 - 3267	23.6 - 24.0
12.29 - 12.293	162.0125 - 167.17	3332 - 3339	31.2 - 31.8
12.51975 - 12.52025	167.72 - 173.2	3345.8 - 3358	36.43 - 36.5
12.57675 - 12.57725	240 - 285	3600 - 4400	(²)
13.36 - 13.41	322 - 335.4		

¹ Until February 1, 1999, this restricted band shall be 0.490-0.510 MHz.

² Above 38.6

(b) Except as provided in paragraphs (d) and (e), the field strength of emissions appearing within these frequency bands shall not exceed the limits shown in Section 15.209. At frequencies equal to or less than 1000 MHz, compliance with the limits in Section 15.209 shall be demonstrated using measurement instrumentation employing a CISPR quasi-peak detector. Above 1000 MHz, compliance with the emission limits in Section 15.209 shall be demonstrated based on the average value of the measured emissions. The provisions in Section 15.35 apply to these measurements.

3.5 DESCRIPTION OF TEST MODES

The EUT (model: A6002) comes with two types of power adapter (model: PA-1100-25 / ADP-10HW A) for sale. After the preliminary test, the power adapter ADP-10HW A was found to emit the worst emissions and therefore had been tested under operating condition.

Software used to control the EUT for staying in continuous transmitting mode was programmed.

After verification, all tests were carried out with the worst case test modes as shown below except radiated spurious emission below 1GHz, which worst case was in normal link mode only.

U-NII-1:

IEEE 802.11a for 5180 ~ 5240MHz:

Channel Low (5180MHz), Channel Mid (5220MHz) and Channel High (5240MHz) with 6Mbps data rate were chosen for full testing.

IEEE 802.11n HT 20 MHz for 5180 ~ 5240MHz:

Channel Low (5180MHz), Channel Mid (5220MHz) and Channel High (5240MHz) with 6.5Mbps data rate were chosen for full testing.

IEEE 802.11n HT 40 MHz Channel for 5190 ~ 5230MHz:

Channel Low (5190MHz) and Channel High (5230MHz) with 13.5Mbps data rate were chosen for full testing.

U-NII-2A:

IEEE 802.11a for 5260 ~ 5320MHz:

Channel Low (5260MHz), Channel Mid (5280MHz) and Channel High (5320MHz) with 6Mbps data rate were chosen for full testing.

IEEE 802.11n HT 20 MHz for 5260 ~ 5320MHz:

Channel Low (5260MHz), Channel Mid (5280MHz) and Channel High (5320MHz) with 6.5Mbps data rate were chosen for full testing.

IEEE 802.11n HT 40 MHz for 5270 ~ 5310MHz:

Channel Low (5270MHz) and Channel High (5310MHz) with 13.5Mbps data rate were chosen for full testing.

U-NII-2C:**IEEE 802.11a for 5500 ~ 5720MHz:**

Channel Low (5500MHz), Channel Mid (5580MHz) and Channel High (5720MHz) with 6Mbps data rate were chosen for full testing.

IEEE 802.11n HT 20 MHz for 5500 ~ 5720MHz:

Channel Low (5500MHz), Channel Mid (5580MHz) and Channel High (5720MHz) with 6.5Mbps data rate were chosen for full testing.

IEEE 802.11n HT 40 MHz for 5510 ~ 5710MHz:

Channel Low (5510MHz), Channel Mid (5550MHz) and Channel High (5710MHz) with 13.5Mbps data rate were chosen for full testing.

For Conducted & Conduction & Radiated above 1GHz

The field strength of spurious emission was measured in the following position: EUT stand-up position (Z axis), lie-down position (X, Y axis). The worst emission was found in lie-down position (X axis) and the worst case was recorded.

For Radiated below 1GHz

The field strength of spurious emission was measured in the following position: EUT stand-up position (Z axis), lie-down position (X, Y axis). The worst emission was found in lie-down position (Y axis) and the worst case was recorded.

4. INSTRUMENT CALIBRATION

4.1 MEASURING INSTRUMENT CALIBRATION

The measuring equipment, which was utilized in performing the tests documented herein, has been calibrated in accordance with the manufacturer's recommendations for utilizing calibration equipment, which is traceable to recognized national standards.

4.2 MEASUREMENT EQUIPMENT USED

Equipment Used for Emissions Measurement

Remark: Each piece of equipment is scheduled for calibration once a year and Loop Antenna is scheduled for calibration once three years.

Conducted Emissions Test Site					
Name of Equipment	Manufacturer	Model	Serial Number	Calibration Date	Calibration Due
DC Power Supplies	GW Instek	SPS-3610	GPE880163	01/19/2016	01/18/2017
Power Meter	Anritsu	ML2495A	1012009	07/08/2015	07/07/2016
Power Sensor	Anritsu	MA2411B	917072	07/08/2015	07/07/2016
Signal Analyzer	R&S	FSV 40	101073	07/20/2015	07/19/2016
Spectrum Analyzer	Agilent	E4446A	US42510268	02/15/2016	02/14/2017
Thermostatic/Hrgrosatic Chamber	TAICHY	MHG-150LF	930619	10/08/2015	10/07/2016
Vector Signal Generator	R&S	SMU 200A	102239	03/10/2016	03/09/2017
AC Power Source	EXTECH	6205	1140845	N.C.R	N.C.R

Wugu 966 Chamber A					
Name of Equipment	Manufacturer	Model	Serial Number	Calibration Date	Calibration Due
Bilog Antenna	Sunol Sciences	JB3	A030105	08/06/2015	08/05/2016
EMI Test Receiver	R&S	ESCI	100064	06/04/2015	06/03/2016
Horn Antenna	EMCO	3117	55165	02/24/2016	02/23/2017
Horn Antenna	EMCO	3116	26370	01/15/2016	01/14/2017
K Type Cable	Huber+Suhner	SUCOFLEX 102	29406/2	01/12/2016	01/11/2017
K Type Cable	Huber+Suhner	SUCOFLEX 102	22470/2	01/12/2016	01/11/2017
Pre-Amplifier	MITEQ	AMF-6F-260400-40-8P	985646	01/14/2016	01/13/2017
Pre-Amplifier	EMCI	EMC 012635	980151	06/05/2015	06/04/2016
Pre-Amplifier	EMCI	EM330	N/A	06/05/2015	06/04/2016
Spectrum Analyzer	Agilent	E4446A	US42510252	12/08/2015	12/07/2016
Antenna Tower	CCS	CC-A-1F	N/A	N.C.R	N.C.R
Controller	CCS	CC-C-1F	N/A	N.C.R	N.C.R
Turn Table	CCS	CC-T-1F	N/A	N.C.R	N.C.R
Software	EZ-EMC (CCS-3A1RE)				

Conducted Emission Room # B					
Name of Equipment	Manufacturer	Model	Serial Number	Calibration Date	Calibration Due
EMI Test Receiver	R&S	ESCI	101073	09/09/2015	09/08/2016
LISN	SCHWARZBECK	NSLK 8127	8127-541	11/23/2015	11/22/2016
LISN	R&S	ENV216	101054	05/07/2015	05/06/2016
Capacitive Voltage Probe	FCC	F-CVP-1	100185	03/09/2016	03/08/2017
Test S/W	CCS-3A1-CE				

4.3 MEASUREMENT UNCERTAINTY

PARAMETER	UNCERTAINTY
Powerline Conducted Emission	+/- 1.2575
3M Semi Anechoic Chamber / 30M~200M	+/- 4.0138
3M Semi Anechoic Chamber / 200M~1000M	+/- 3.9483
3M Semi Anechoic Chamber / 1G~8G	+/- 2.5975
3M Semi Anechoic Chamber / 8G~18G	+/- 2.6112
3M Semi Anechoic Chamber / 18G~26G	+/- 2.7389
3M Semi Anechoic Chamber / 26G~40G	+/- 2.9683

Remark: This uncertainty represents an expanded uncertainty expressed at approximately the 95% confidence level using a coverage factor of $k=2$.

5. FACILITIES AND ACCREDITATIONS

5.1 FACILITIES

All measurement facilities used to collect the measurement data are located at

- No.199, Chunghsen Road, Hsintien City, Taipei Hsien, Taiwan, R.O.C.
Tel: 886-2-2217-0894 / Fax: 886-2-2217-1029
- No.11, Wugong 6th Rd., Wugu Dist., New Taipei City 24891, Taiwan. (R.O.C.)
Tel: 886-2-2299-9720 / Fax: 886-2-2298-4045
- No.81-1, Lane 210, Bade 2nd Rd., Luchu Hsiang, Taoyuan Hsien 338, Taiwan
Tel: 886-3-324-0332 / Fax: 886-3-324-5235

The sites are constructed in conformance with the requirements of ANSI C63.7, ANSI C63.10: 2013 and CISPR Publication 22.

5.2 EQUIPMENT

Radiated emissions are measured with one or more of the following types of linearly polarized antennas: tuned dipole, biconical, log periodic, bi-log, ridged waveguide, horn and/or Loop. Spectrum analyzers with pre-selectors and quasi-peak detectors are used to perform radiated measurements.

Conducted emissions are measured with Line Impedance Stabilization Networks and EMI Test Receivers.



Calibrated wideband preamplifiers, coaxial cables, and coaxial attenuators are also used for making measurements.

All receiving equipment conforms to CISPR Publication 16-1, "Radio Interference Measuring Apparatus and Measurement Methods."

5.3 LABORATORY ACCREDITATIONS AND LISTING

The test facilities used to perform radiated and conducted emissions tests are accredited by American Association for Laboratory Accreditation Program for the specific scope accreditation under Lab Code: 0824-01 to perform Electromagnetic Interference tests according to FCC Part 15 and CISPR 22 requirements. In addition, the test facilities are listed with Industry Canada, Certification and Engineering Bureau, IC 2324G-1 for 3M Semi Anechoic Chamber A, 2324G-2 for 3M Semi Anechoic Chamber B.

5.4 TABLE OF ACCREDITATIONS AND LISTINGS

Country	Agency	Scope of Accreditation	Logo
USA	FCC	3M Semi Anechoic Chamber (FCC MRA: TW1039) to perform FCC Part 15 measurements	 FCC MRA: TW1039
Taiwan	TAF	LP0002, RTTE01, FCC Method-47 CFR Part 15 Subpart C, D, E, RSS-247, RSS-310 IDA TS SRD, AS/NZS 4268, AS/NZS 4771, TS 12.1 & 12.2, ETSI EN 300 440-1, ETSI EN 300 440-2, ETSI EN 300 328, ETSI EN 300 220-1, ETSI EN 300 220-2, ETSI EN 301 893, ETSI EN 301 489-1/3/7/17 FCC OET Bulletin 65 + Supplement C, EN 50360, EN 50361, EN 50371, RSS 102, EN 50383, EN 50385, EN 50392, IEC 62209, CNS 14958-1, CNS 14959 FCC Method -47 CFR Part 15 Subpart B IEC / EN 61000-3-2, IEC / EN 61000-3-3, IEC / EN 61000-4-2/3/4/5/6/8/11	
Canada	Industry Canada	3M Semi Anechoic Chamber (IC 2324G-1 / IC 2324G-2) to perform	 IC 2324G-1 IC 2324G-2

** No part of this report may be used to claim or imply product endorsement by A2LA or any agency of the US Government.*

6. SETUP OF EQUIPMENT UNDER TEST

6.1 SETUP CONFIGURATION OF EUT

See test photographs attached in Appendix I for the actual connections between EUT and support equipment.

6.2 SUPPORT EQUIPMENT

No.	Device Type	Brand	Model	Series No.	FCC ID	Data Cable	Power Cord
1	Notebook PC	TOSHIBA	Satellite M840	N/A	PPD-AR5B225	N/A	AC I/P: Unshielded, 1.8m DC O/P: Unshielded, 1.8m with a core

Remark:

1. All the equipment/cables were placed in the worst-case configuration to maximize the emission during the test.
2. Grounding was established in accordance with the manufacturer's requirements and conditions for the intended use.

7. FCC PART 15 REQUIREMENTS & RSS-247 REQUIREMENTS

7.1 99% BANDWIDTH

Test Configuration

TEST PROCEDURE

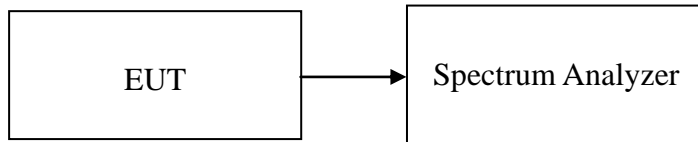

The resolution bandwidth shall be set to as close to 1% of the selected span as is possible without being below 1%. The video bandwidth shall be set to 3 times the resolution bandwidth. Video averaging is not permitted. Where practical, a sampling detector shall be used since a peak or, peak hold.

TEST RESULTS**Test mode: IEEE 802.11a mode / 5180 ~ 5240MHz**

Channel	Frequency (MHz)	99% Bandwidth (MHz)
Low	5180	16.9871
Mid	5220	16.8589
High	5240	16.8589

Test mode: IEEE 802.11n HT 20 MHz mode / 5180 ~ 5240MHz

Channel	Frequency (MHz)	99% Bandwidth (MHz)
Low	5180	17.6923
Mid	5220	17.7564
High	5240	17.7564

Test mode: IEEE 802.11n HT 40 MHz mode / 5190 ~ 5230MHz

Channel	Frequency (MHz)	99% Bandwidth (MHz)
Low	5190	36.4102
High	5230	36.4102

Test mode: IEEE 802.11a mode / 5260 ~ 5320MHz

Channel	Frequency (MHz)	99% Bandwidth (MHz)
Low	5260	16.9871
Mid	5280	16.7948
High	5320	16.9871

Test mode: IEEE 802.11n HT 20 MHz mode / 5260 ~ 5320MHz

Channel	Frequency (MHz)	99% Bandwidth (MHz)
Low	5260	17.7564
Mid	5280	17.6923
High	5320	17.7564

Test mode: IEEE 802.11n HT 40 MHz mode / 5270 ~ 5310MHz

Channel	Frequency (MHz)	99% Bandwidth (MHz)
Low	5270	36.4102
High	5310	36.4102

Test mode: IEEE 802.11a mode / 5500 ~ 5700MHz

Channel	Frequency (MHz)	99% Bandwidth (MHz)
Low	5500	16.9871
Mid	5580	16.8589
High	5700	16.9230

Test mode: IEEE 802.11n HT 20 MHz mode / 5500 ~ 5700MHz

Channel	Frequency (MHz)	99% Bandwidth (MHz)
Low	5500	17.6923
Mid	5580	17.7564
High	5700	17.6923

Test mode: IEEE 802.11n HT 40 MHz mode / 5510 ~ 5710MHz

Channel	Frequency (MHz)	99% Bandwidth (MHz)
Low	5510	36.4102
Mid	5550	36.4102
High	5670	36.4102

99% Bandwidth (CH high)

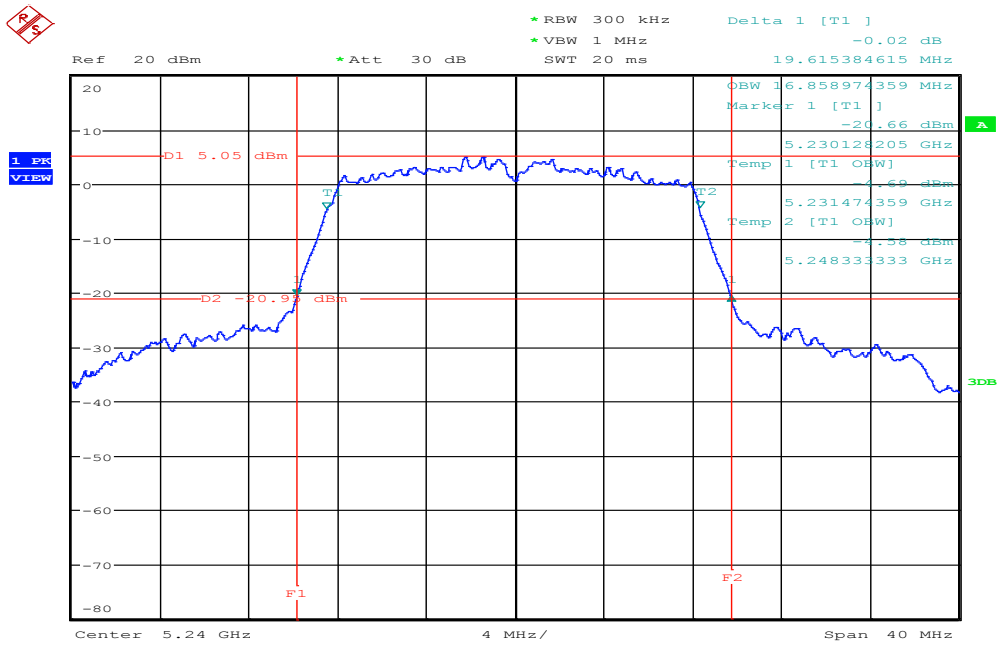

Date: 1.APR.2016 17:45:40

IEEE 802.11n HT 20 MHz mode / 5180 ~ 5240MHz

99% Bandwidth (CH Low)

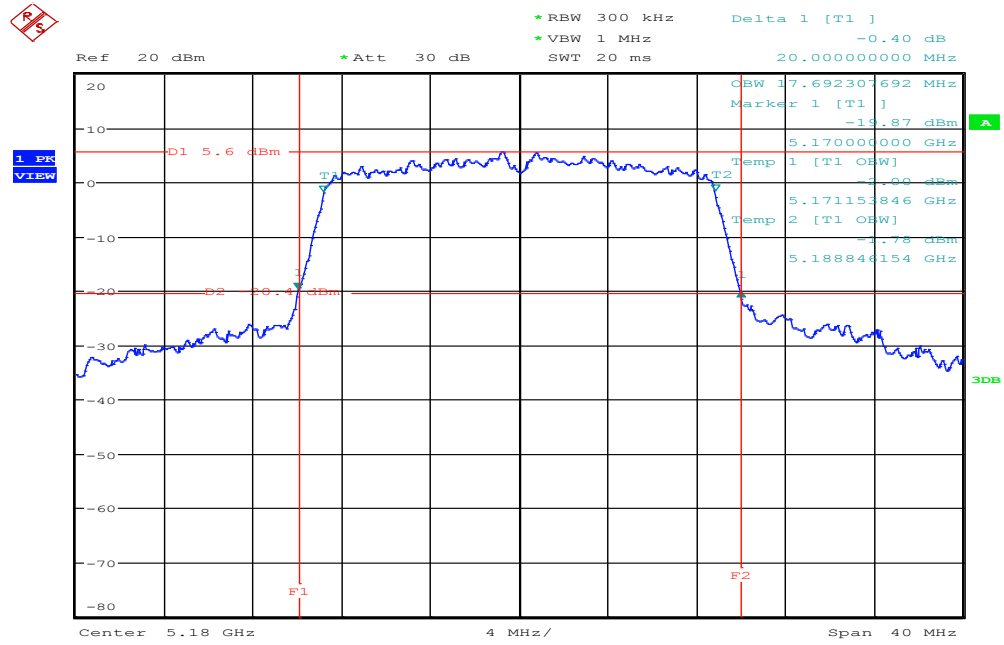

Date: 1.APR.2016 18:22:36

99% Bandwidth (CH Mid)

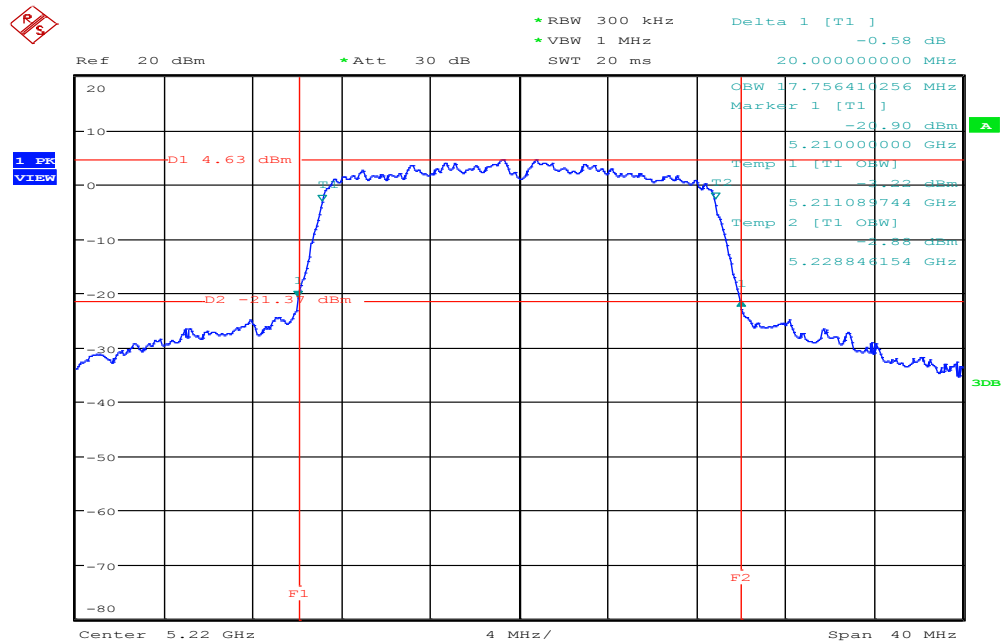

Date: 1.APR.2016 18:25:26

IEEE 802.11n HT 40 MHz mode / 5190 ~ 5230MHz

99% Bandwidth (CH Low)

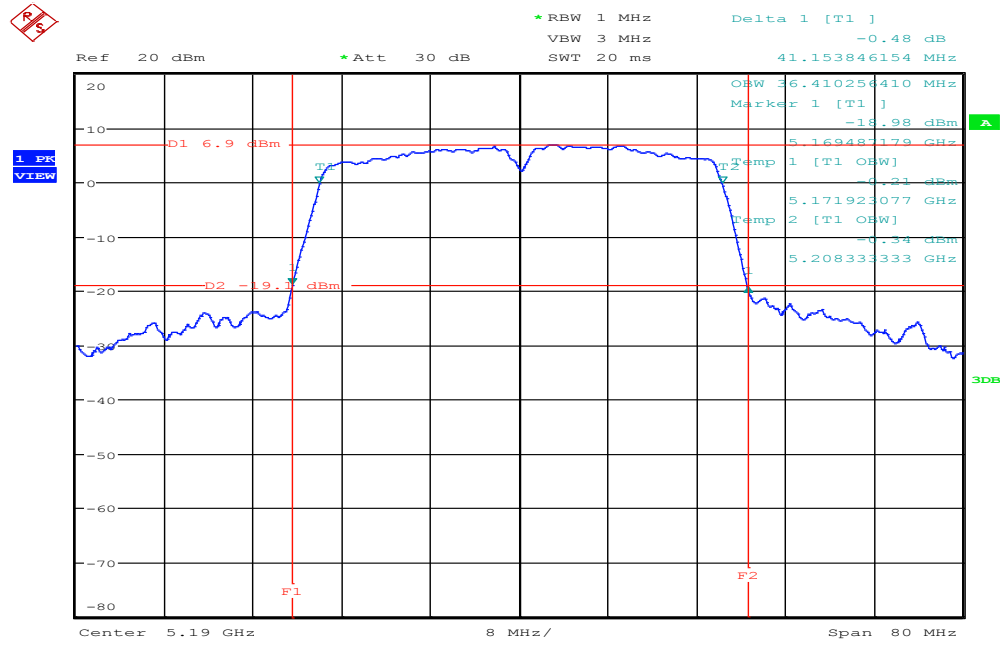

Date: 6.APR.2016 11:08:48

99% Bandwidth (CH High)

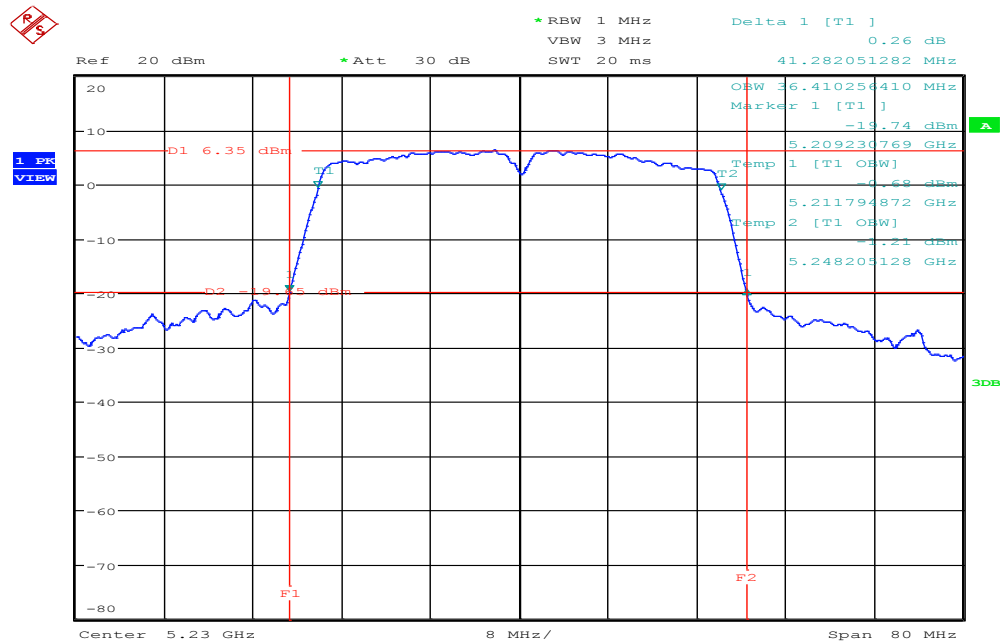

Date: 6.APR.2016 10:38:47

IEEE 802.11a mode / 5260 ~ 5320MHz

99% Bandwidth (CH Low)

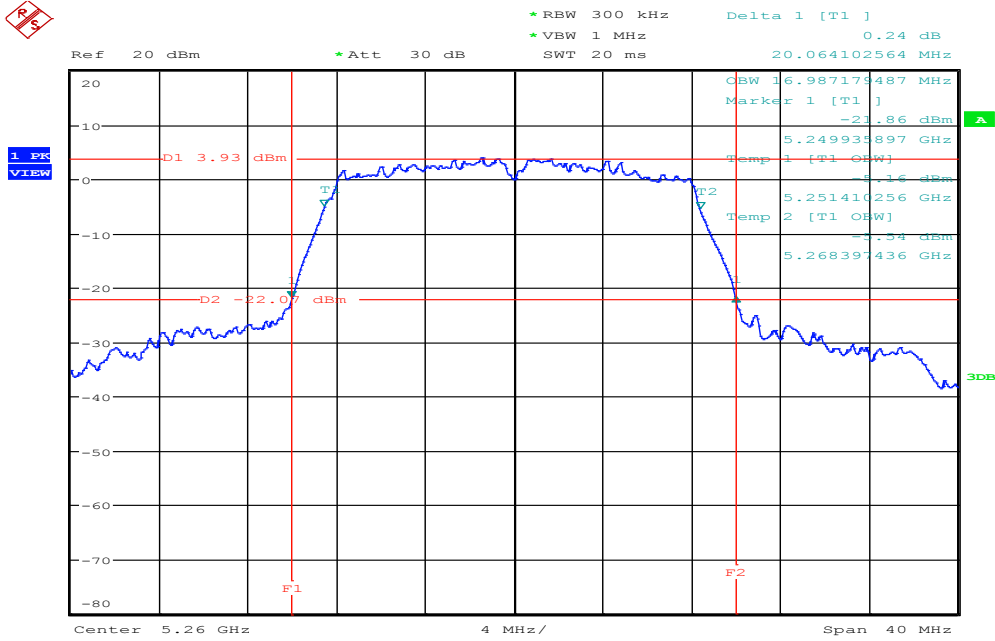

Date: 1.APR.2016 17:48:13

99% Bandwidth (CH Mid)

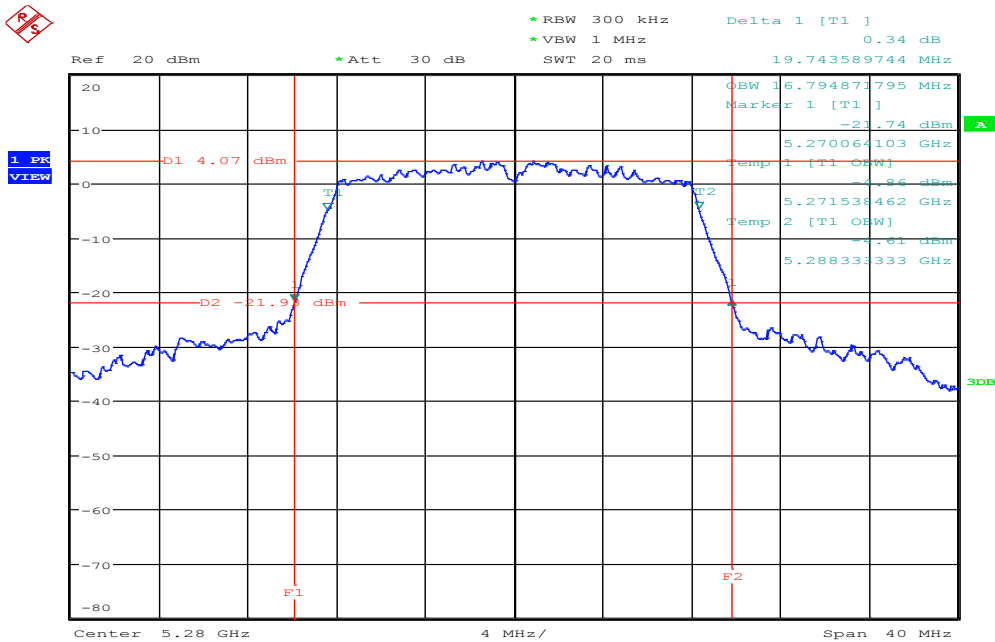

Date: 1.APR.2016 17:54:14

99% Bandwidth (CH High)

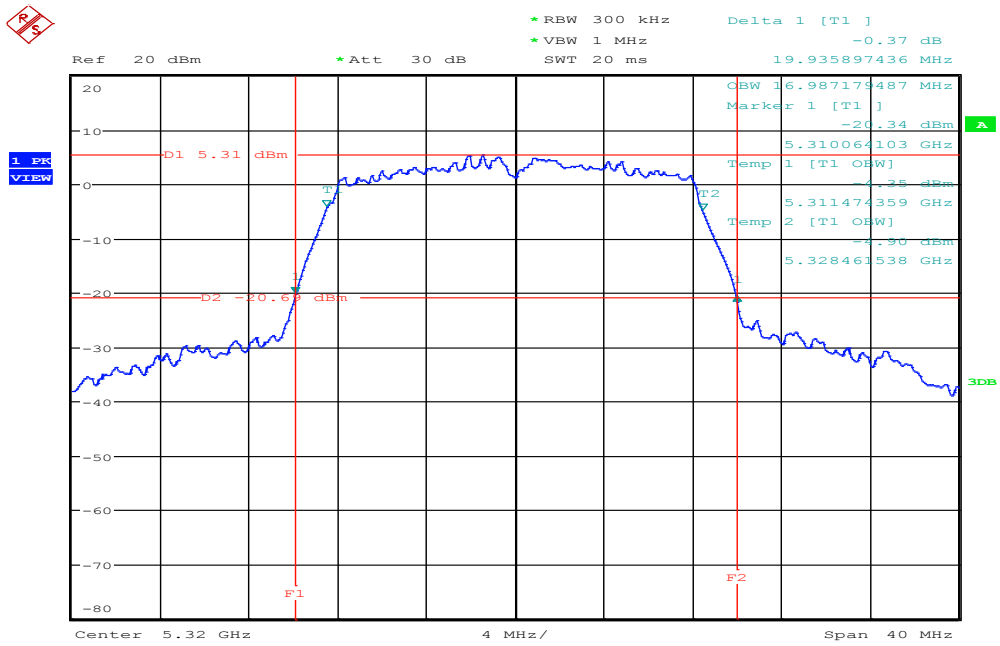

Date: 1.APR.2016 17:57:56

IEEE 802.11n HT 20 MHz mode / 5260 ~ 5320MHz

99% Bandwidth (CH Low)

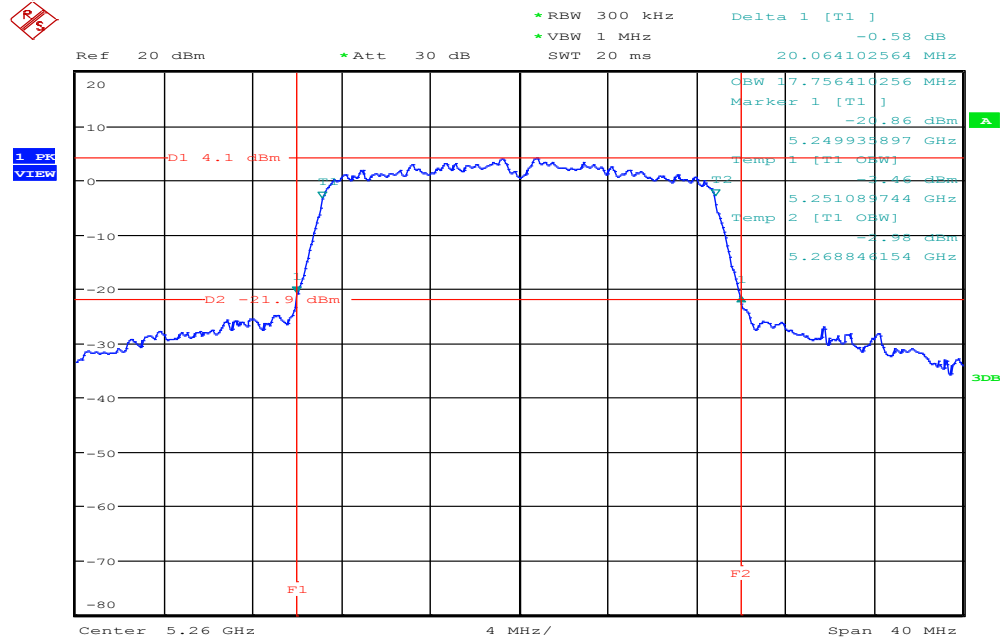

Date: 1.APR.2016 18:30:14

99% Bandwidth (CH Mid)

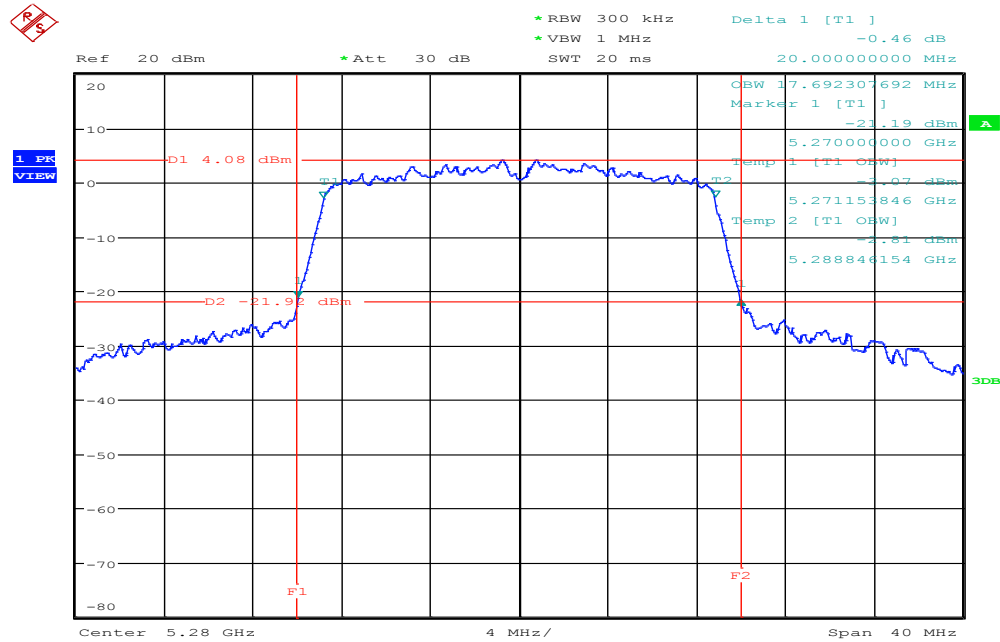

Date: 1.APR.2016 18:32:03

IEEE 802.11n HT 40 MHz mode / 5270 ~ 5310MHz

99% Bandwidth (CH Low)

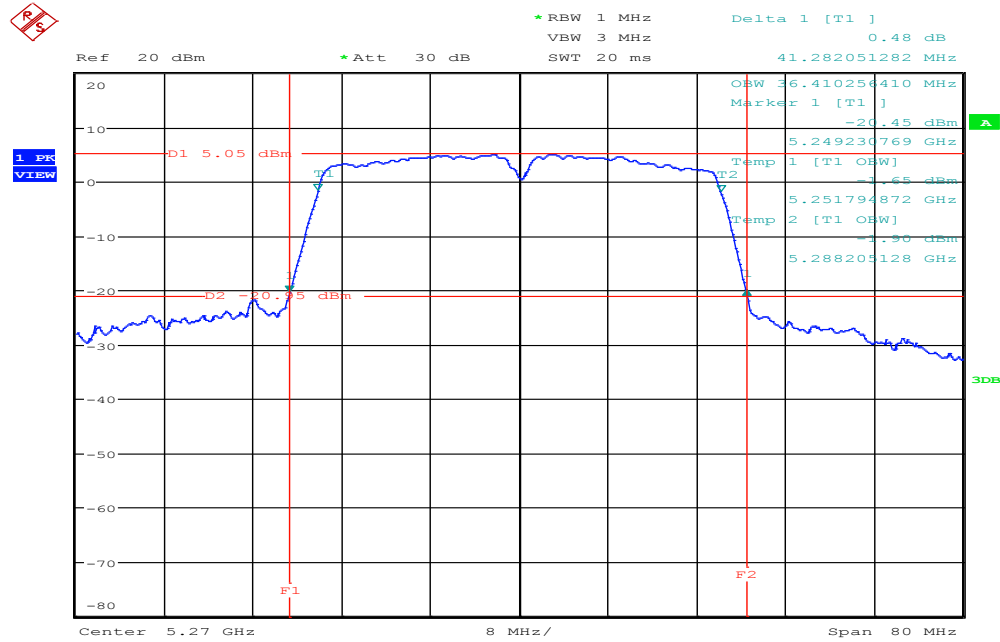

Date: 6.APR.2016 10:41:17

99% Bandwidth (CH High)

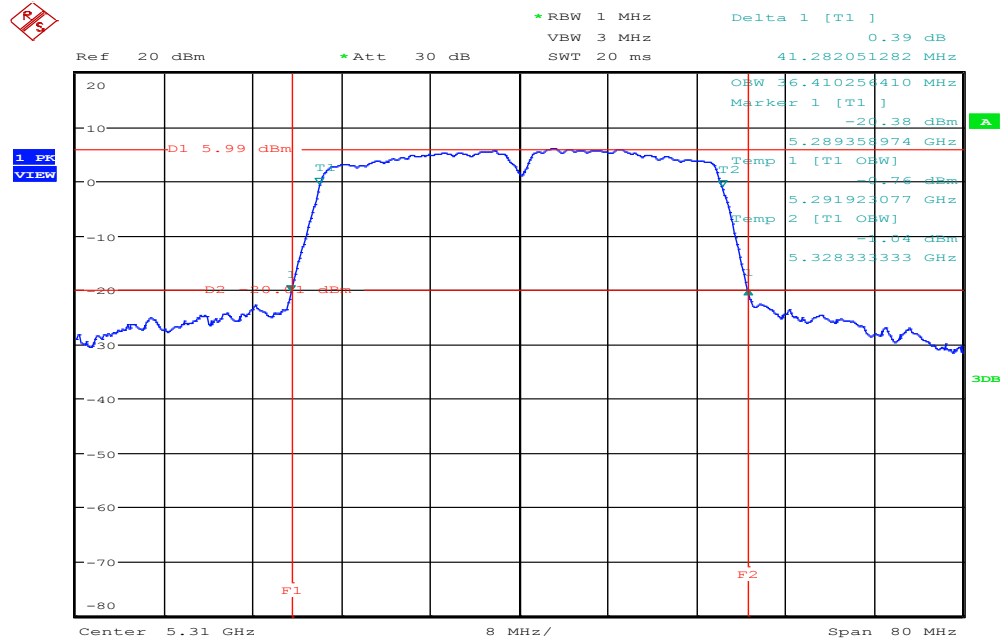

Date: 6.APR.2016 10:44:58

Test mode: IEEE 802.11a mode / 5500 ~ 5700MHz

99% Bandwidth (CH Low)

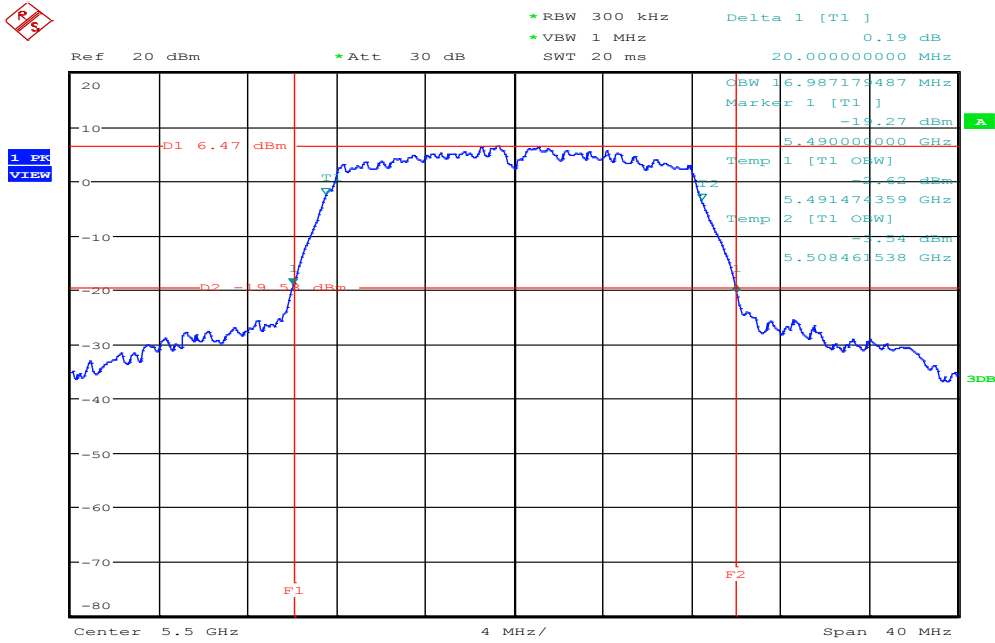

Date: 1.APR.2016 18:03:35

99% Bandwidth (CH Mid)

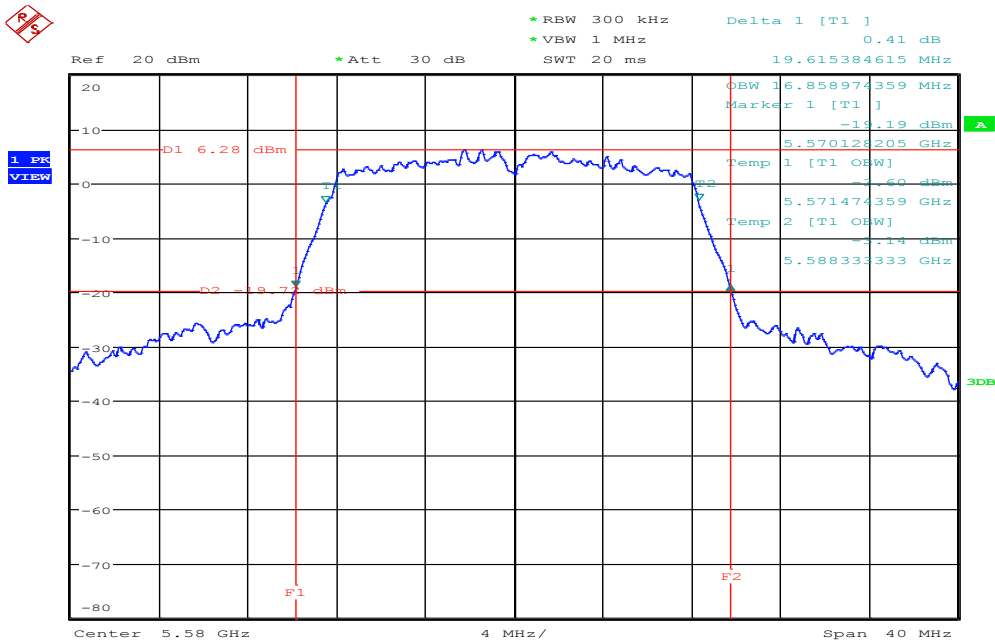

Date: 1.APR.2016 18:06:51

99% Bandwidth (CH High)

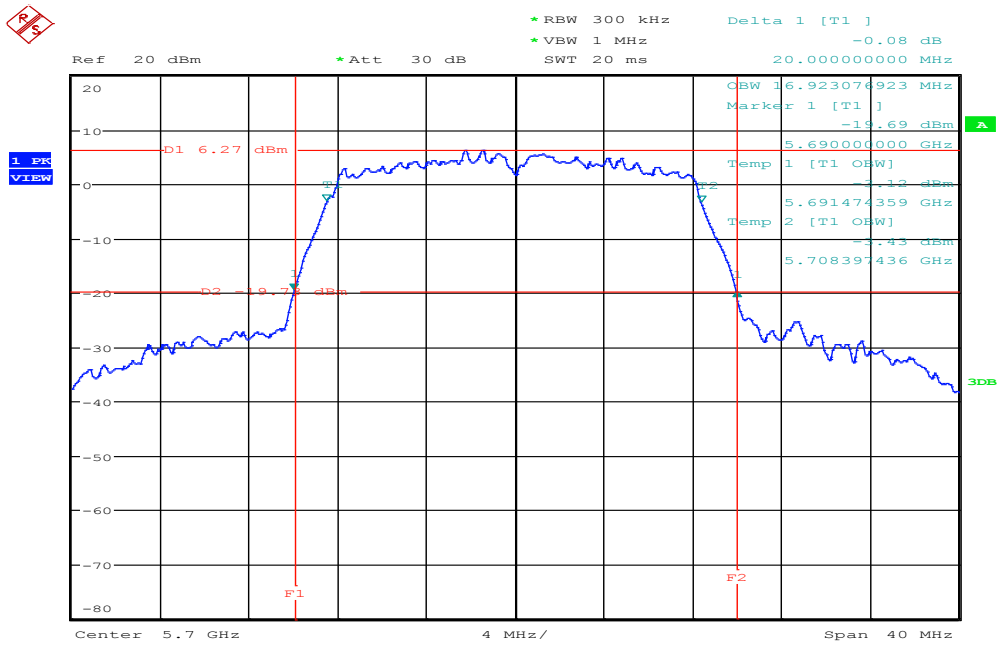

Date: 1.APR.2016 18:10:42

IEEE 802.11n HT 20 MHz mode / 5500 ~ 5700MHz

99% Bandwidth (CH Low)

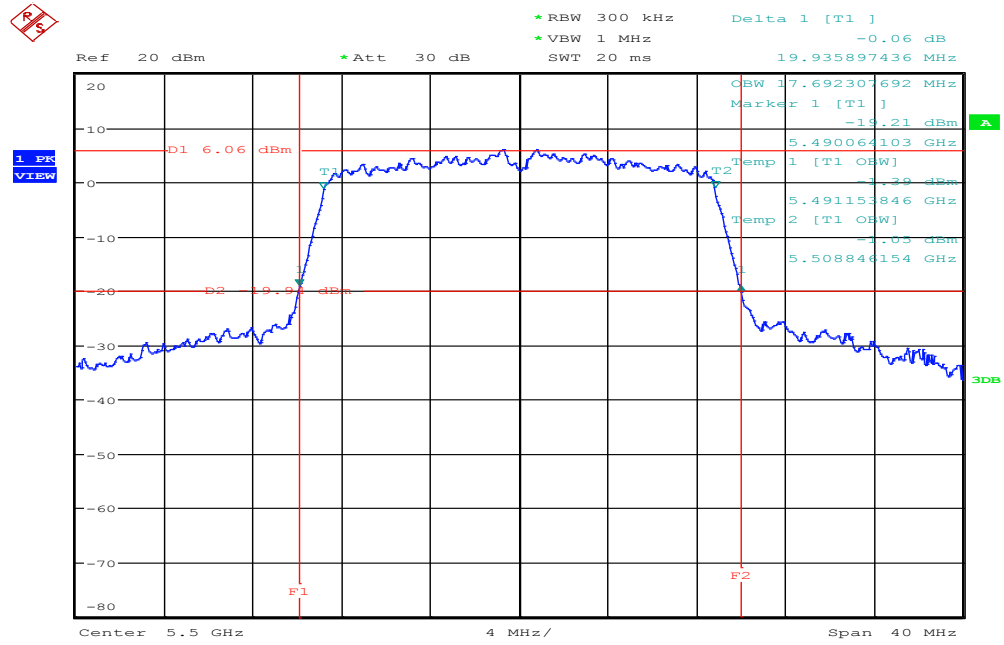

Date: 1.APR.2016 18:38:32

99% Bandwidth (CH Mid)

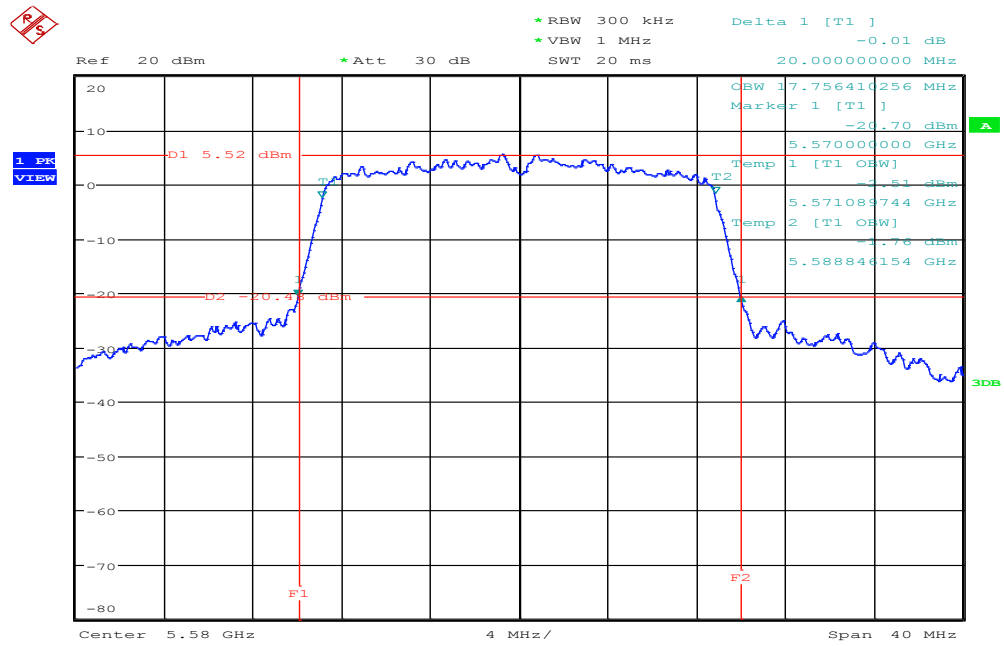

Date: 1.APR.2016 18:40:19

99% Bandwidth (CH High)

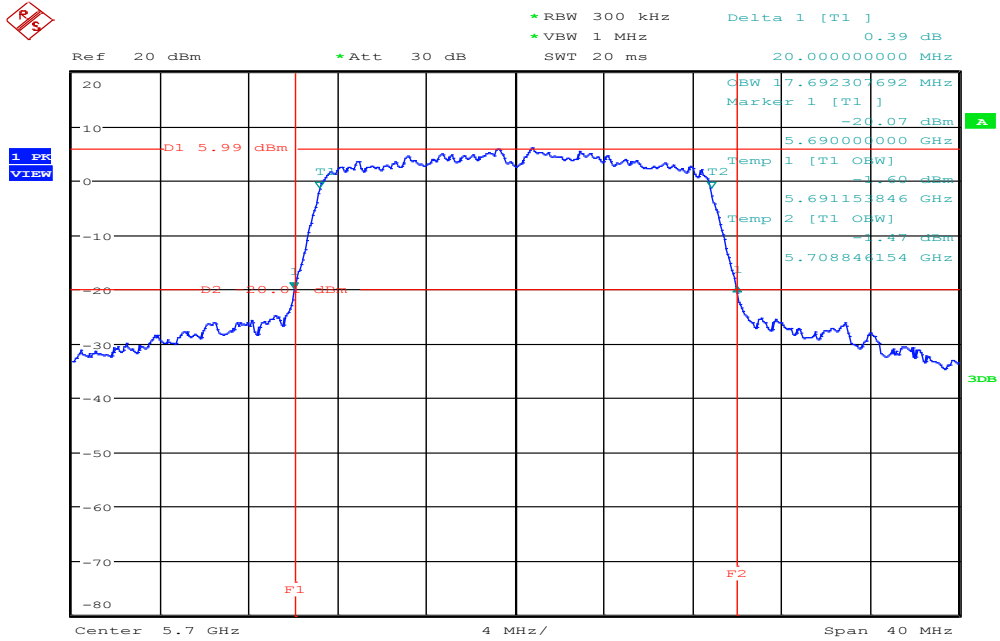

Date: 1.APR.2016 18:42:29

IEEE 802.11n HT 40 MHz mode / 5510 ~ 5670MHz

99% Bandwidth (CH Low)

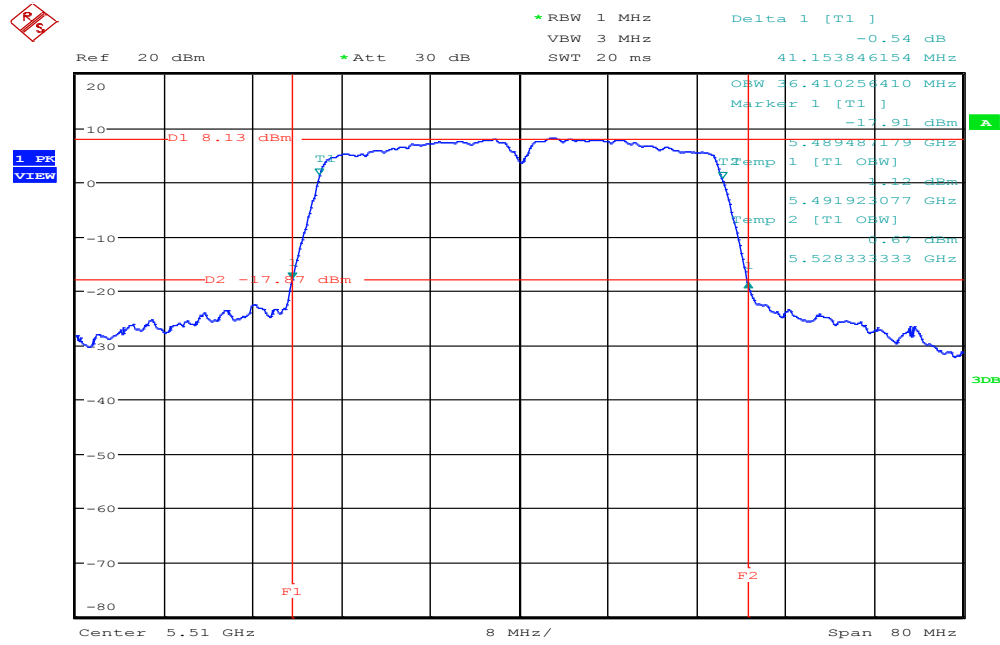

Date: 6.APR.2016 10:48:39

99% Bandwidth (CH Mid)

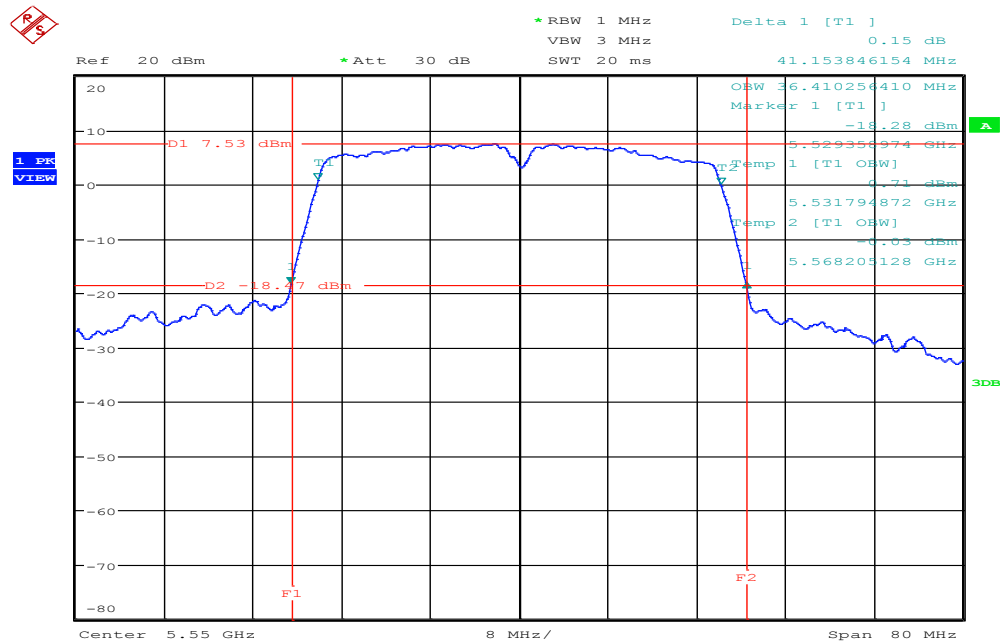

Date: 6.APR.2016 10:54:04

99% Bandwidth (CH High)

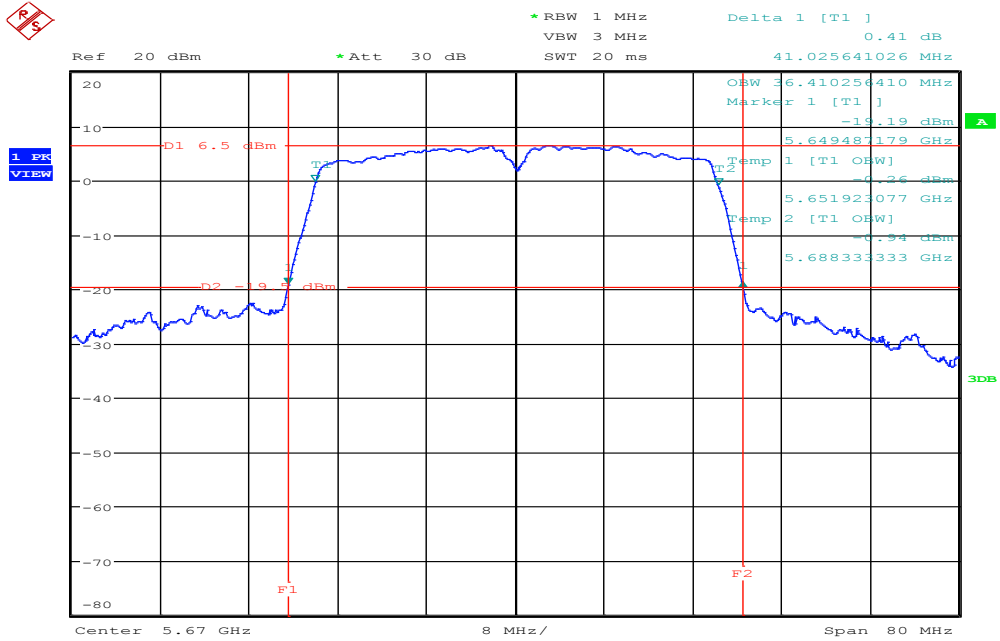

Date: 6.APR.2016 10:55:52

7.2 26 dB EMISSION BANDWIDTH

LIMIT

Measure the maximum width of the emission that is 26 dB down from the maximum of the emission. Compare this with the RBW setting of the analyzer. Readjust RBW and repeat measurement as needed until the RBW/EBW ratio is approximately 1%.

Test Configuration

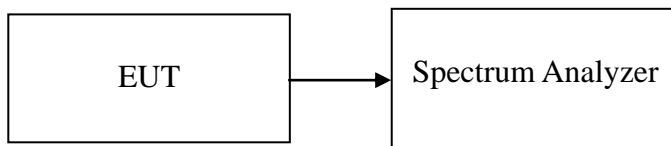

TEST PROCEDURE

1. Place the EUT on the table and set it in the transmitting mode.
2. Remove the antenna from the EUT and then connect a low-loss RF cable from the antenna port to the spectrum analyzer.
3. Set the spectrum analyzer as $RBW > 1\%EBW$, $VBW > RBW$, $Span > 26dB$ bandwidth, and Sweep = auto.
4. Mark the peak frequency and $-26dB$ (upper and lower) frequency.
5. Repeat until all the rest channels were investigated.

TEST RESULTS

No non-compliance noted

Test Data**Test mode: IEEE 802.11a mode / 5180 ~ 5240MHz**

Channel	Frequency (MHz)	26db Bandwidth (MHz)
Low	5180	19.9358
Mid	5220	19.7435
High	5240	19.6153

Test mode: IEEE 802.11n HT 20 MHz mode / 5180 ~ 5240MHz

Channel	Frequency (MHz)	26db Bandwidth (MHz)
Low	5180	20.0000
Mid	5220	20.0000
High	5240	20.0000

Test mode: IEEE 802.11n HT 40 MHz mode / 5190 ~ 5230MHz

Channel	Frequency (MHz)	26db Bandwidth (MHz)
Low	5190	41.1538
Mid	5230	41.2820

Test mode: IEEE 802.11a mode / 5260 ~ 5320MHz

Channel	Frequency (MHz)	26db Bandwidth (MHz)
Low	5260	20.0641
Mid	5280	19.7435
High	5320	19.9358

Test mode: IEEE 802.11n HT 20 MHz mode / 5260 ~ 5320MHz

Channel	Frequency (MHz)	26db Bandwidth (MHz)
Low	5260	20.0641
Mid	5280	20.0000
High	5320	19.9358

Test mode: IEEE 802.11n HT 40 MHz mode / 5270 ~ 5310MHz

Channel	Frequency (MHz)	26db Bandwidth (MHz)
Low	5270	41.2820
Mid	5310	41.2820

Test mode: IEEE 802.11a mode / 5500 ~ 5700MHz

Channel	Frequency (MHz)	26db Bandwidth (MHz)
Low	5500	20.0000
Mid	5580	19.6153
High	5700	20.0000

Test mode: IEEE 802.11n HT 20 MHz mode / 5500 ~ 5700MHz

Channel	Frequency (MHz)	26db Bandwidth (MHz)
Low	5500	19.9358
Mid	5580	20.0000
High	5700	20.0000

Test mode: IEEE 802.11n HT 40 MHz mode / 5510 ~ 5670MHz

Channel	Frequency (MHz)	26db Bandwidth (MHz)
Low	5510	41.1538
Mid	5550	41.1538
High	5670	41.0256

Test Plot

IEEE 802.11a for 5180 ~ 5240MHz

CH Low

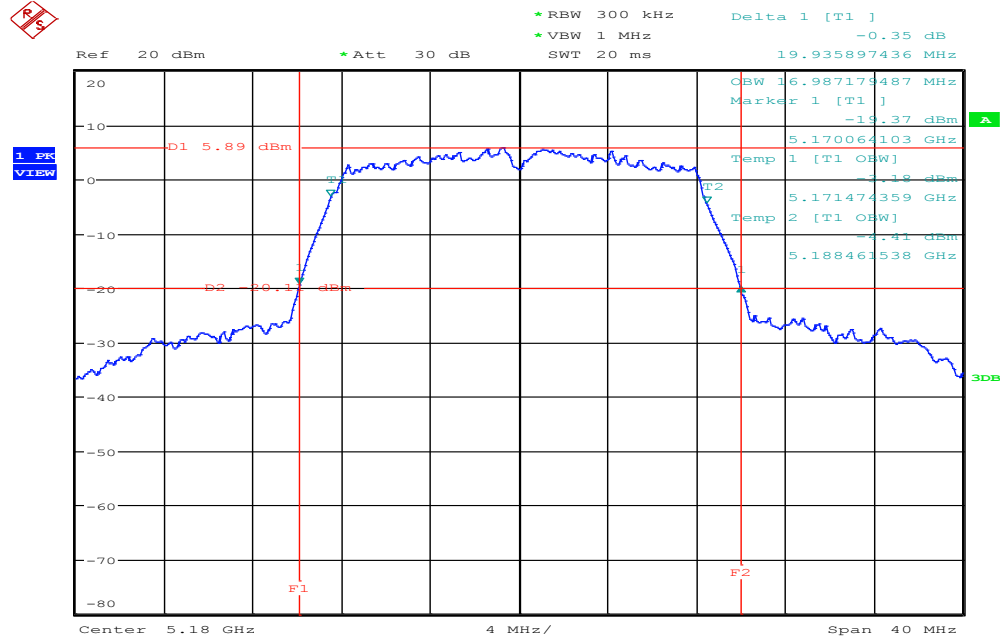

Date: 1.APR.2016 17:39:49

CH Mid

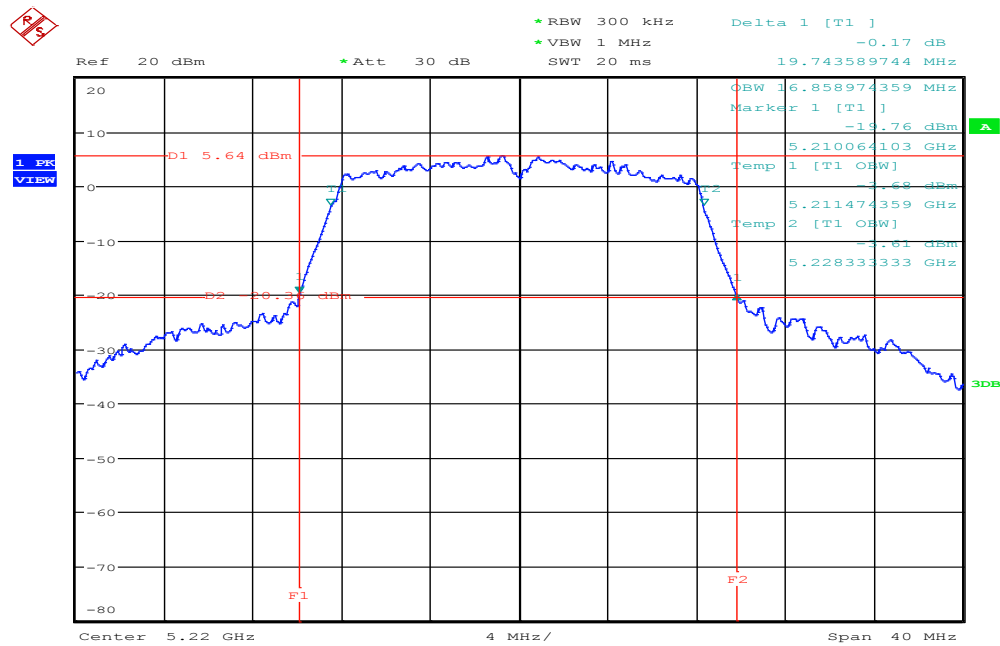

Date: 1.APR.2016 17:42:14

IEEE 802.11n HT 20 MHz mode / 5180 ~ 5240MHz

CH Low

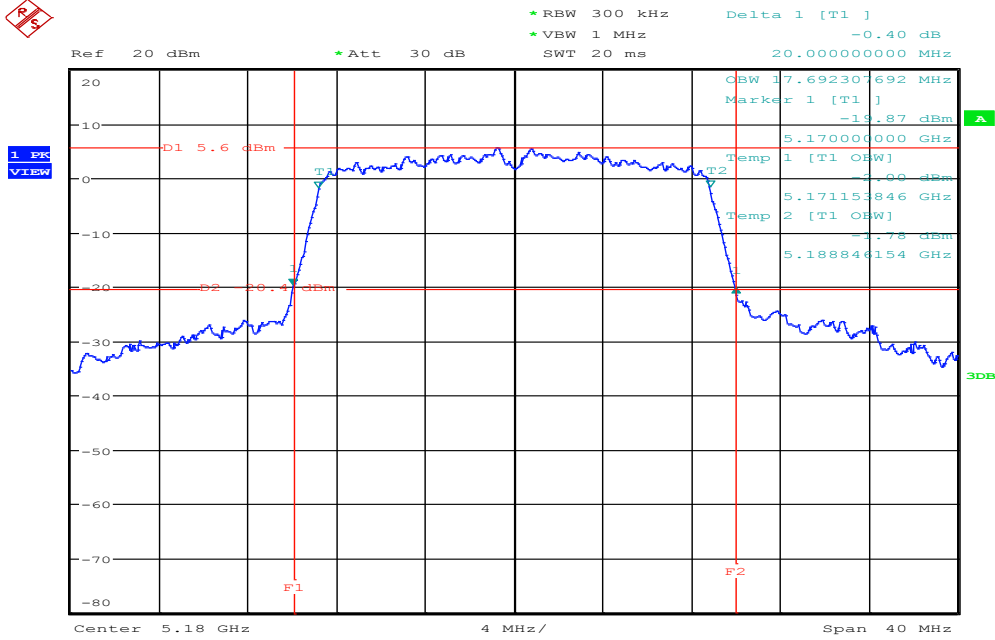

Date: 1.APR.2016 18:22:36

CH Mid

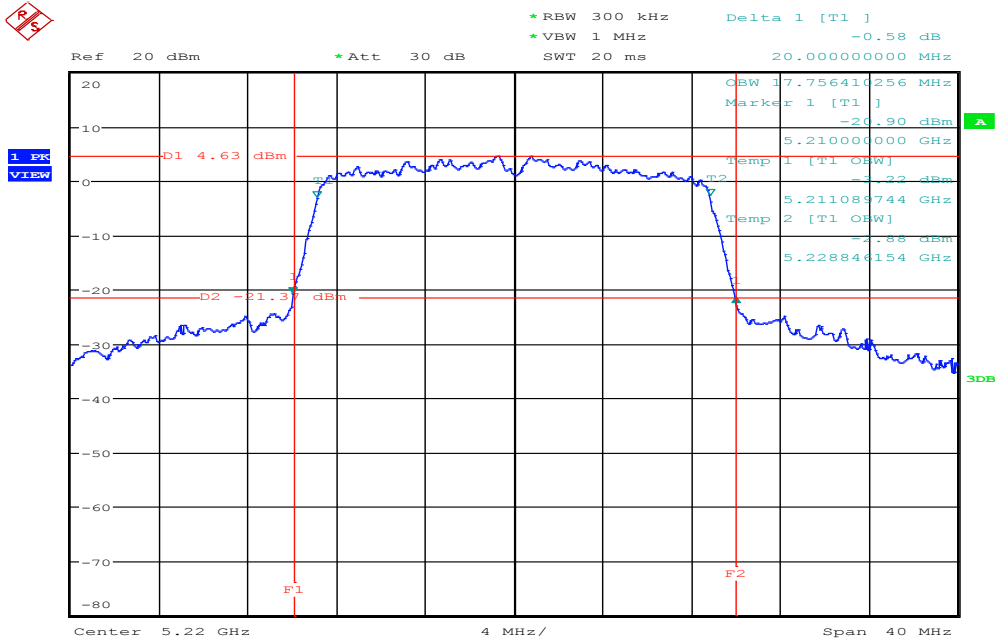

Date: 1.APR.2016 18:25:26

CH High

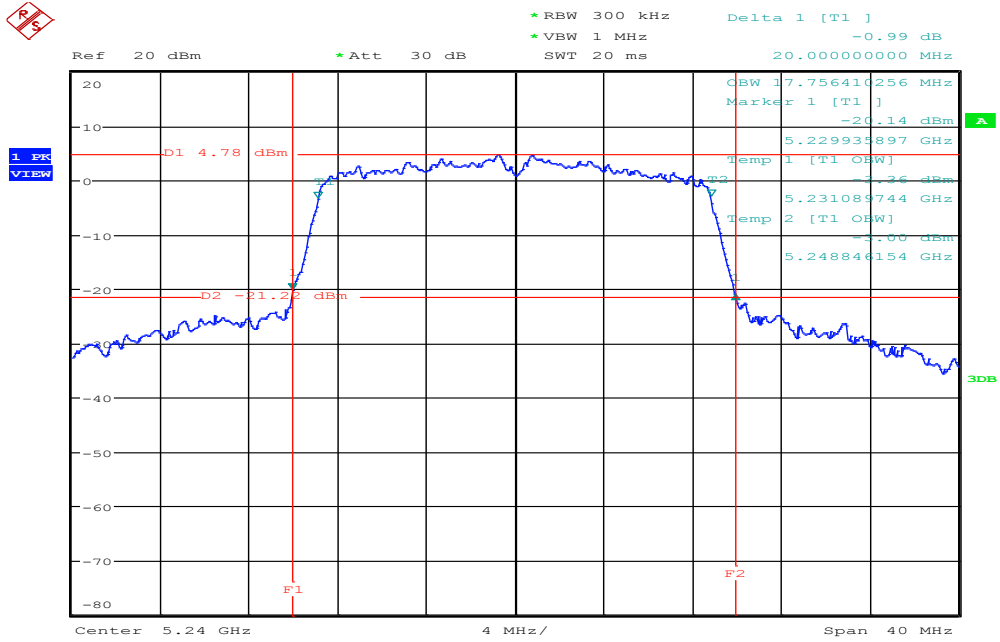

Date: 1.APR.2016 18:27:25

IEEE 802.11n HT 40 MHz mode / 5190 ~ 5230MHz

CH Low

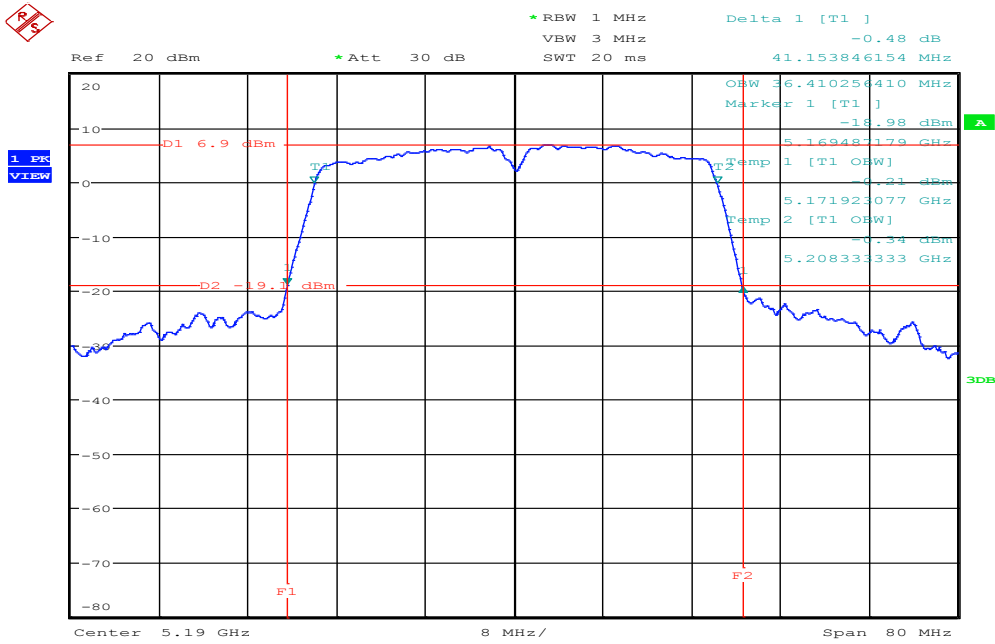

Date: 6.APR.2016 11:08:48

CH High

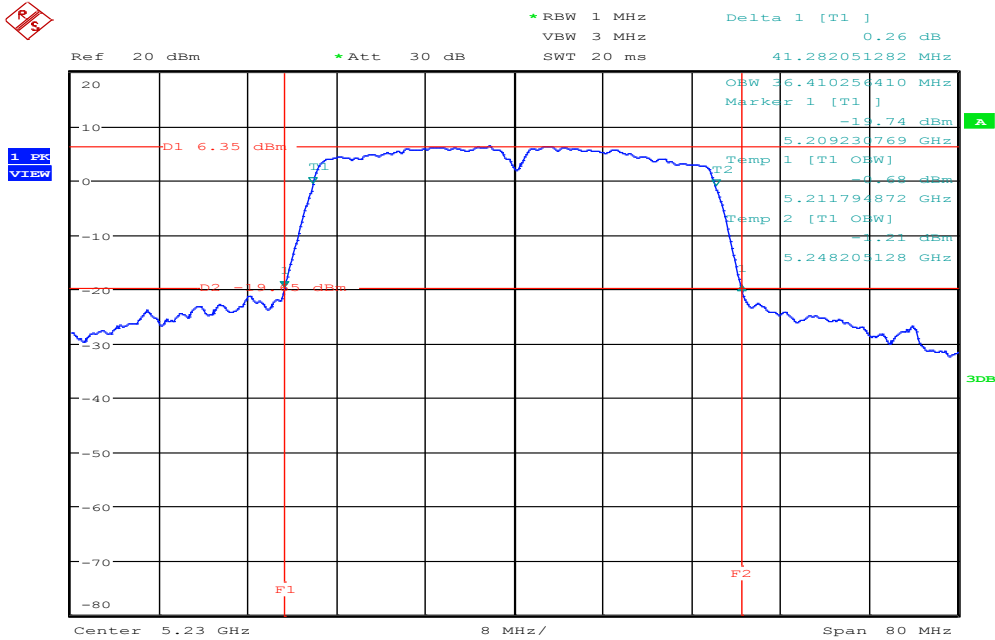

Date: 6.APR.2016 10:38:47

IEEE 802.11a mode / 5260 ~ 5320MHz

CH Low

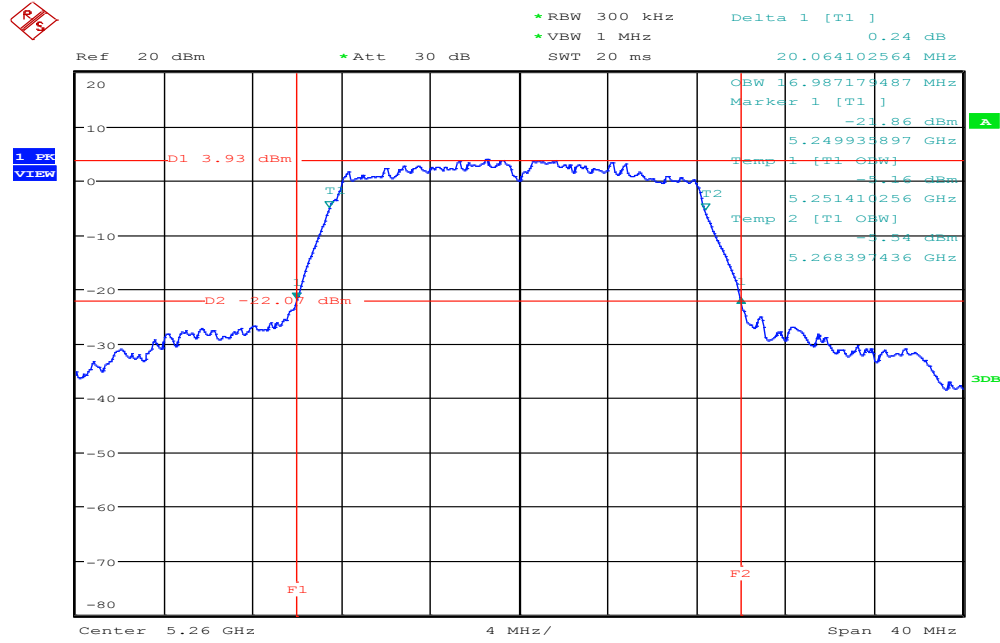

Date: 1.APR.2016 17:48:13

CH Mid

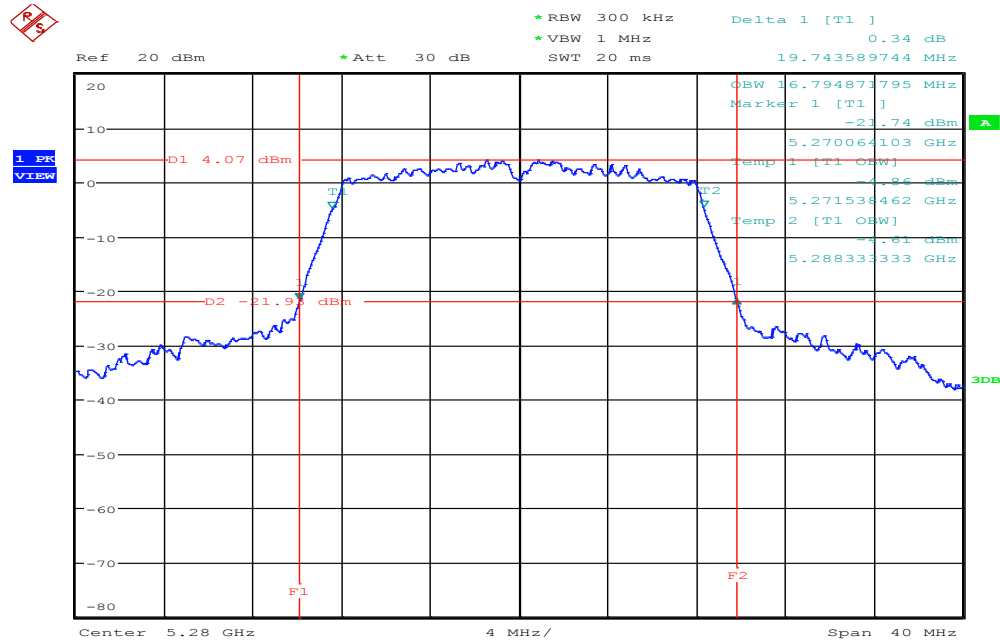

Date: 1.APR.2016 17:54:14

CH High

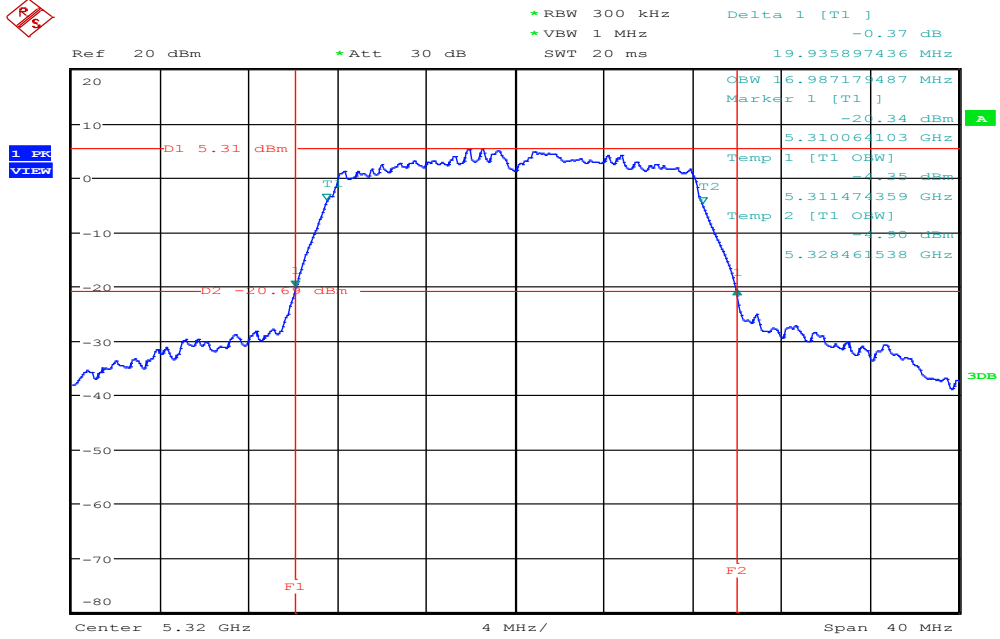

Date: 1.APR.2016 17:57:56

IEEE 802.11n HT 20 MHz mode / 5260 ~ 5320MHz

CH Low

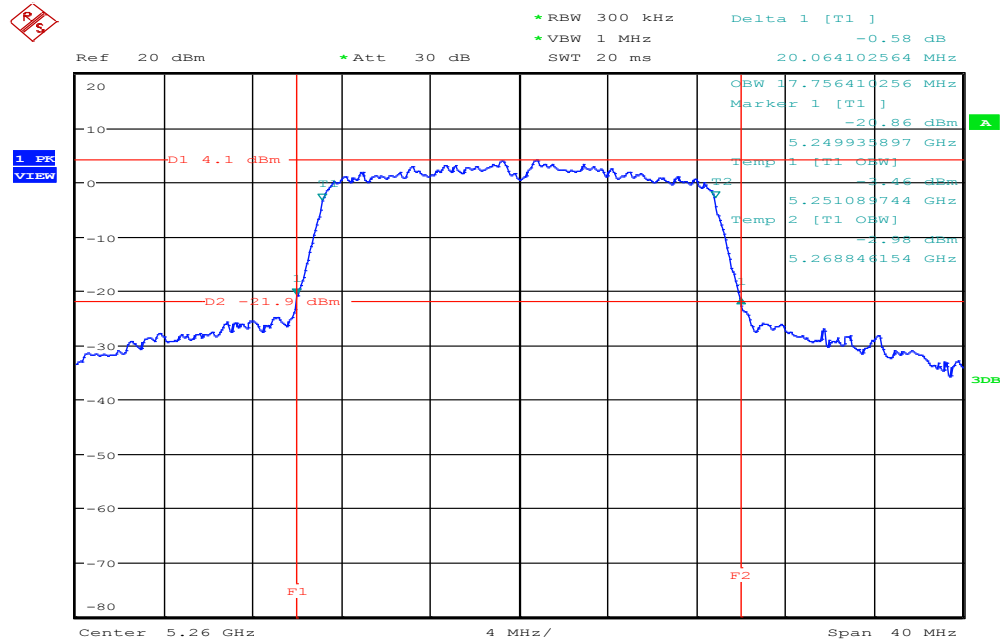

Date: 1.APR.2016 18:30:14

CH Mid

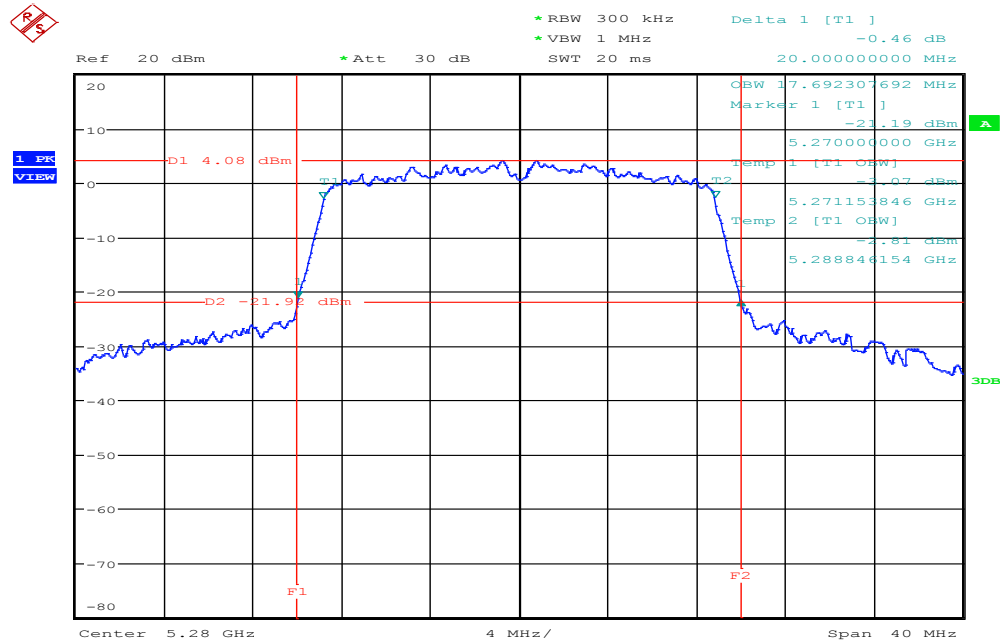

Date: 1.APR.2016 18:32:03

CH High

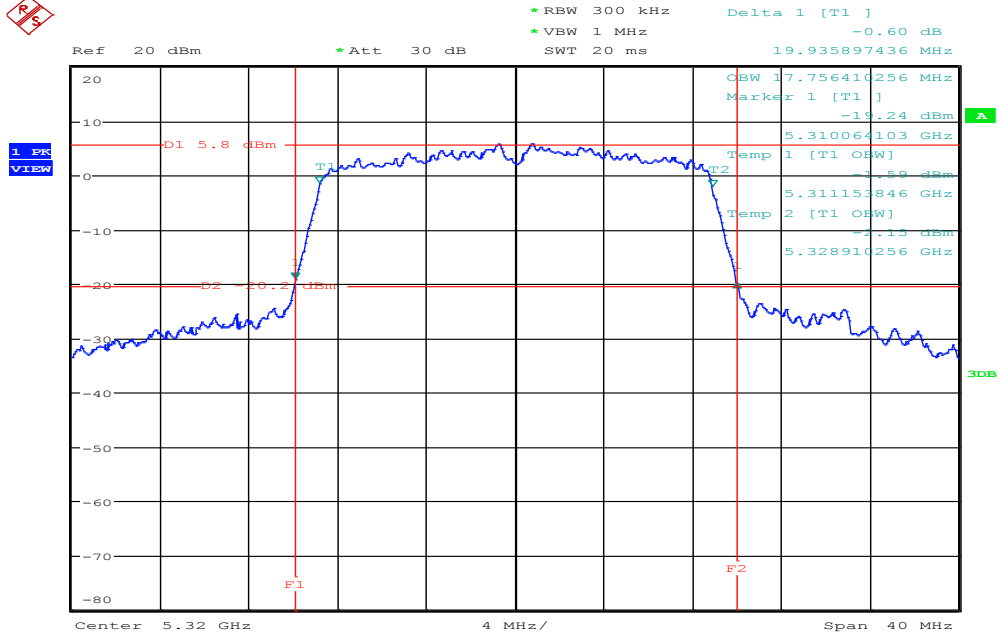

Date: 1.APR.2016 18:34:36

IEEE 802.11n HT 40 MHz mode / 5270 ~ 5310MHz

CH Low

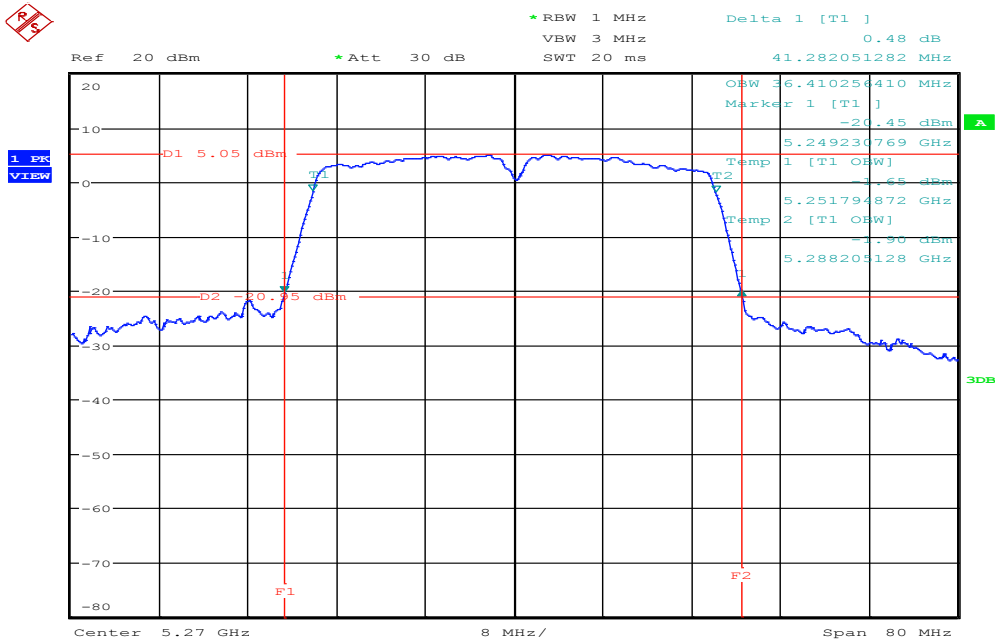

Date: 6.APR.2016 10:41:17

CH High

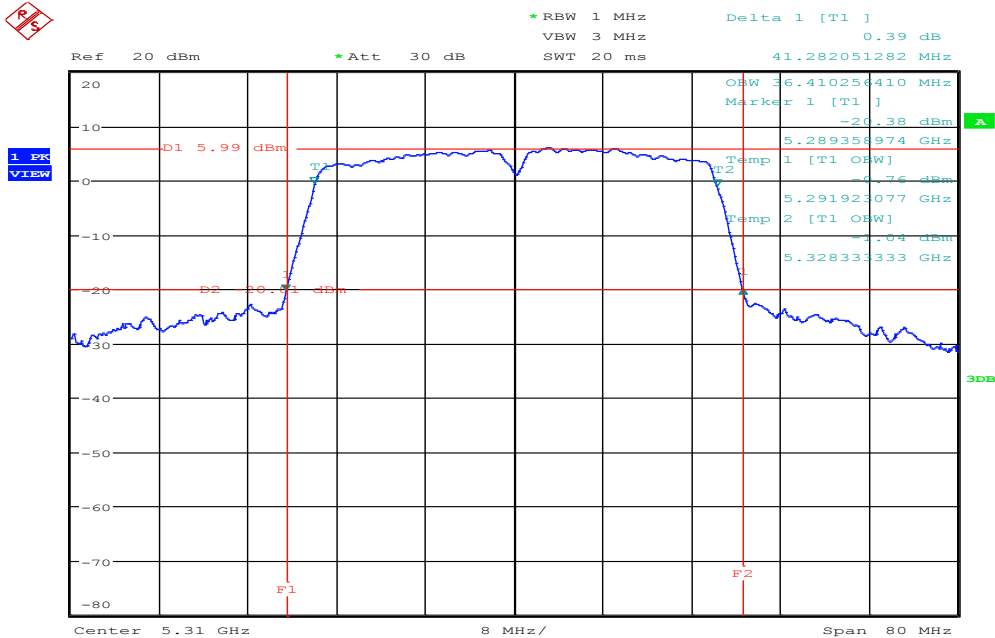

Date: 6.APR.2016 10:44:58

Test mode: IEEE 802.11a mode / 5500 ~ 5700MHz

CH Low

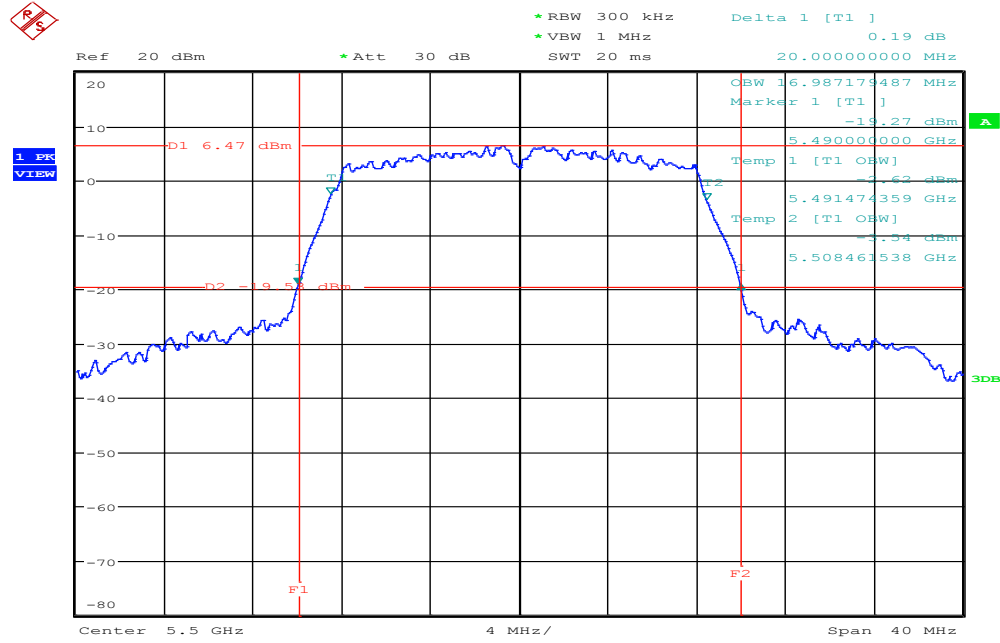

Date: 1.APR.2016 18:03:35

CH Mid

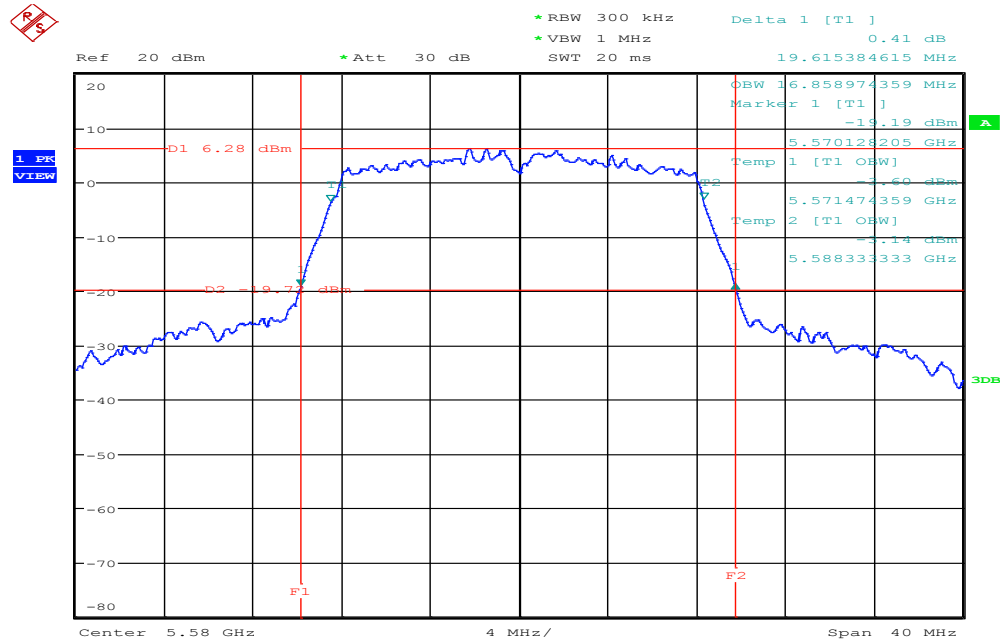

Date: 1.APR.2016 18:06:51

IEEE 802.11n HT 20 MHz mode / 5500 ~ 5720MHz

CH Low

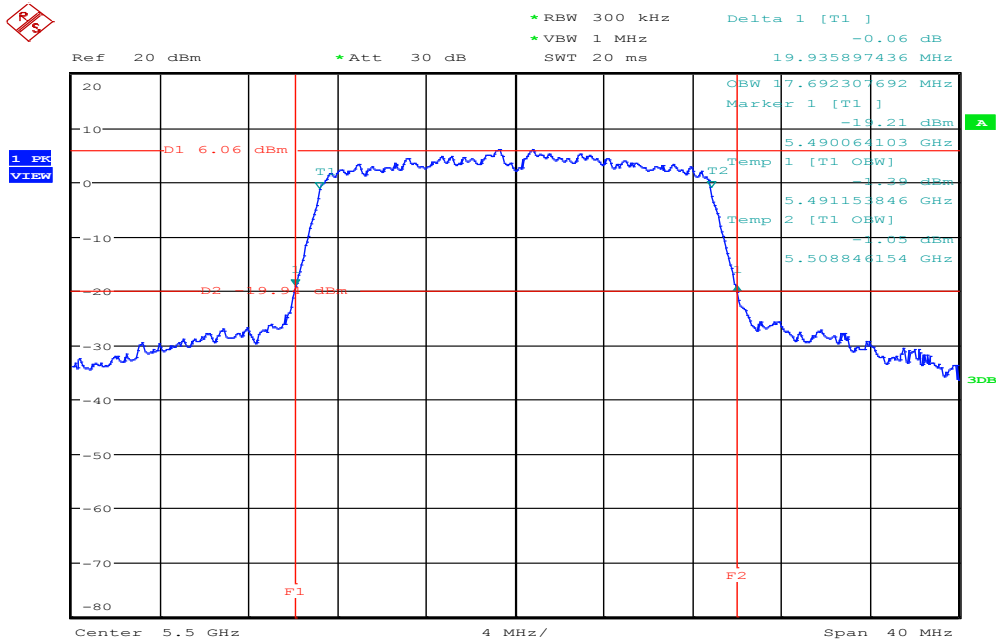

Date: 1.APR.2016 18:38:32

CH Mid

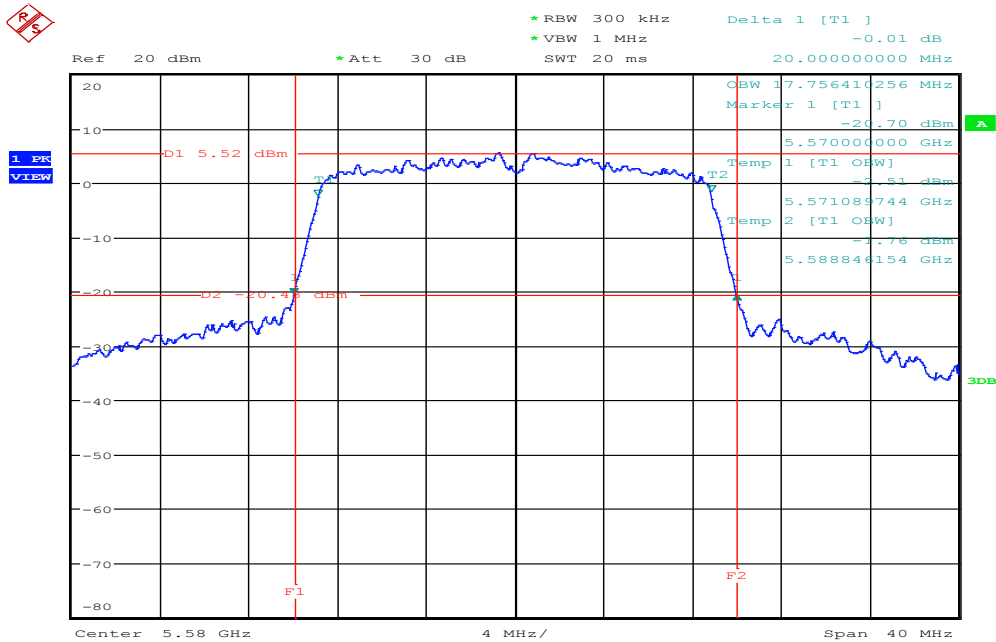

Date: 1.APR.2016 18:40:19

CH High

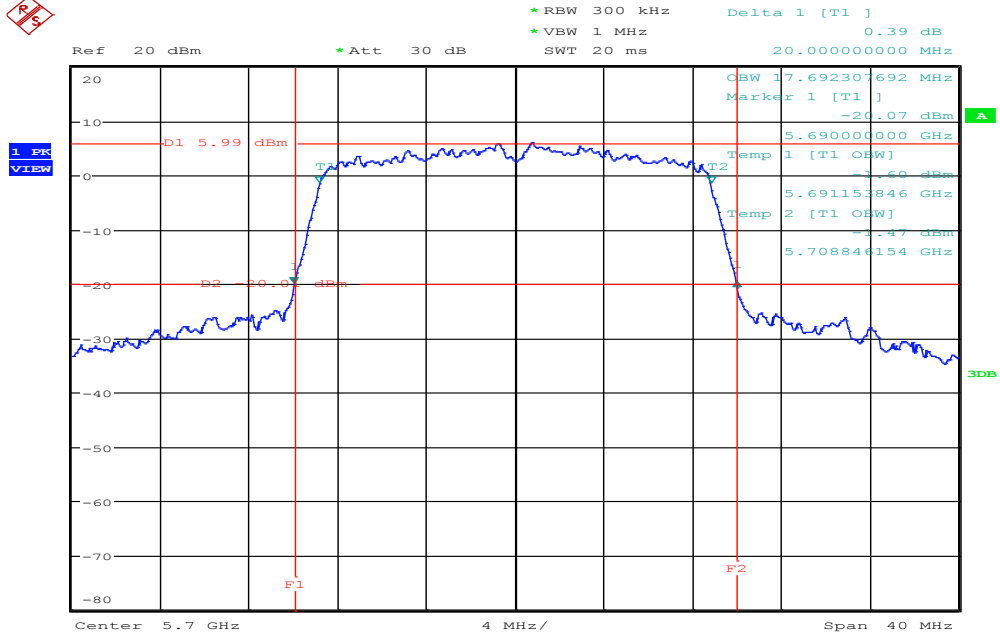

Date: 1.APR.2016 18:42:29

IEEE 802.11n HT 40 MHz mode / 5510 ~ 5670MHz

CH Low

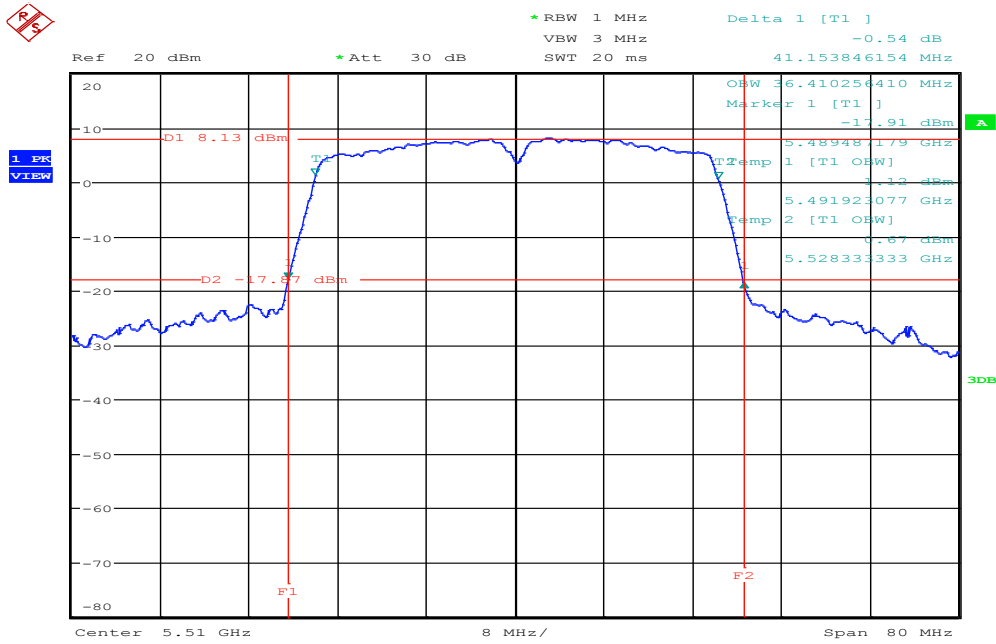

Date: 6.APR.2016 10:48:39

CH Mid

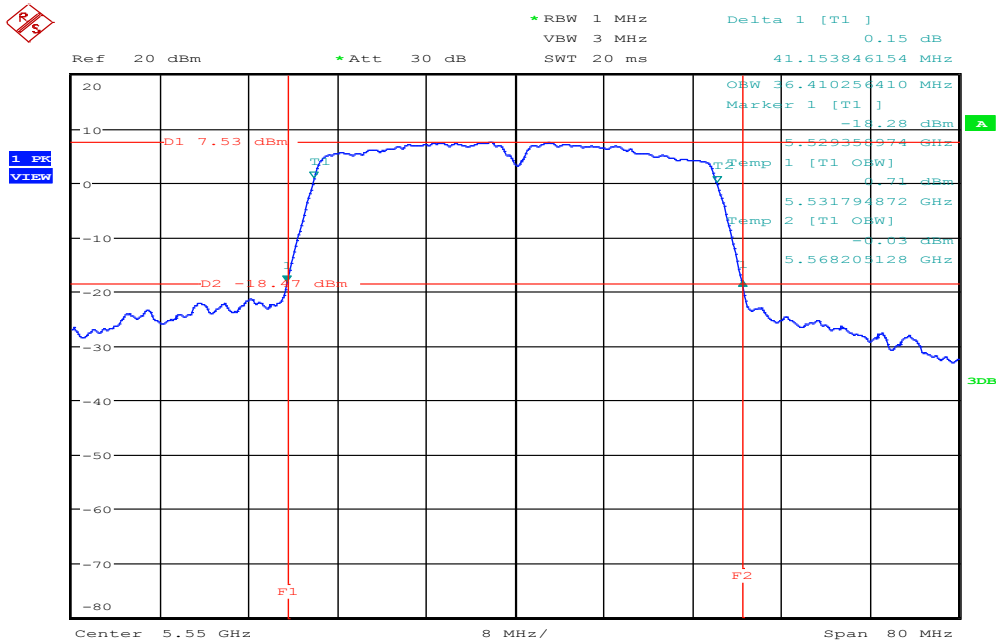

Date: 6.APR.2016 10:54:04

CH High

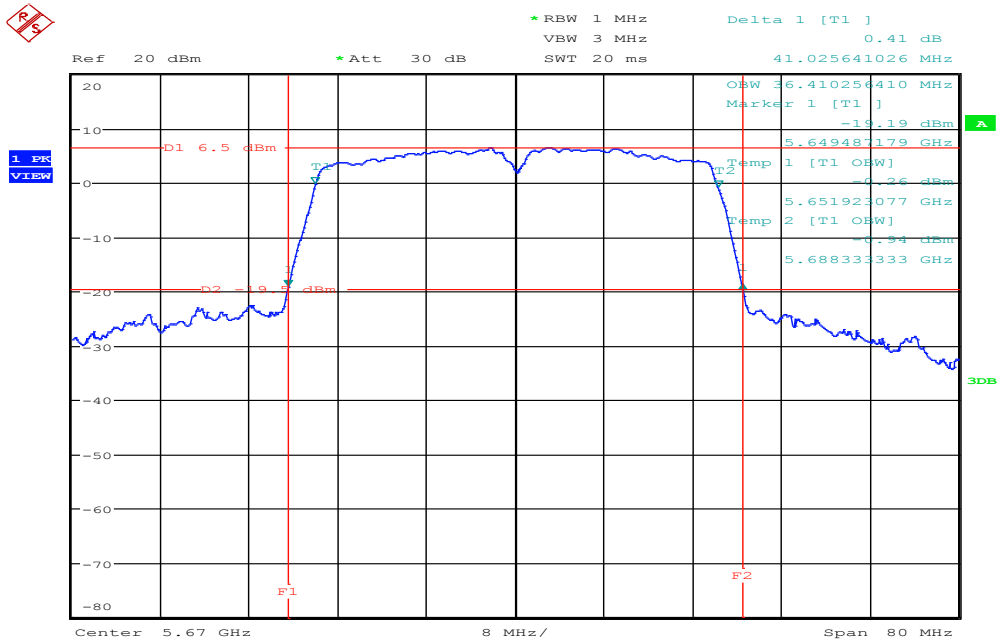

Date: 6.APR.2016 10:55:52

7.3 MAXIMUM CONDUCTED OUTPUT POWER

LIMIT

According to §15.407(a)

For the band 5.15-5.25 GHz, 5.25-5.35 GHz and 5.47-5.725 GHz bands, the maximum conducted output power over the frequency band of operation shall not exceed the lesser of 250 mW or 11 dBm + 10log B, where B is the 26 dB emission bandwidth in MHz.

If transmitting antennas of directional gain greater than 6dBi are used, both the peak transmit power and the peak power spectral density shall be reduced by the amount in dB that the directional gain of the antenna exceeds 6dBi

According to RSS-247,

- (1) For the band 5150-5250 MHz, the maximum equivalent isotropically radiated power (e.i.r.p.) shall not exceed 200 mW or 10 + 10 Log₁₀ B, dBm, whichever power is less. B is the 99% emission bandwidth in MHz. The e.i.r.p. spectral density shall not exceed 10 dBm in any 1.0 MHz band.
- (2) For the band 5250-5350 MHz and 5470-5725 MHz, the maximum conducted output power shall not exceed 250 mW or 11 + 10 Log₁₀ B, dBm, whichever power is less. The power spectral density shall not exceed 11 dBm in any 1.0 MHz band. The maximum e.i.r.p. shall not exceed 1.0 W or 17 + 10 Log₁₀ B, dBm, whichever power is less. B is the 99% emission bandwidth in MHz.

In addition, devices with maximum e.i.r.p. greater than 500 mW shall implement TPC in order to have the capability to operate at least 6 dB below the maximum permitted e.i.r.p. of 1 W.

The peak power shall not exceed the limit as follow:

Test Configuration

The EUT was connected to a spectrum analyzer through a 50Ω RF cable.

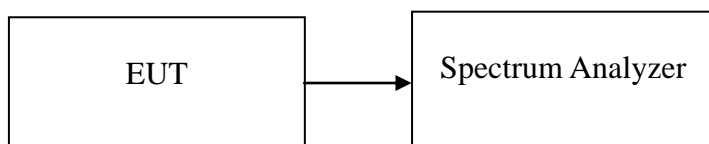

TEST PROCEDURE

Set span to encompass the entire emission bandwidth (EBW) of the signal.

Set RBW = 1 MHz / Set VBW = 3 MHz.

Use sample detector mode if bin width (i.e., span/number of points in spectrum display) < 0.5 RBW. Otherwise use peak detector mode. Use a video trigger with the trigger level set to enable triggering only on full power pulses. Transmitter must operate at full control power for entire sweep of every sweep. If the device transmits continuously, with no off intervals or reduced power intervals, the trigger may be set to "free run". Trace average 100 traces in power averaging mode. Compute power by integrating the spectrum across the 26 dB EBW of the signal. The integration can be performed using the spectrum analyzer's band power measurement function with band limits set equal to the EBW band edges or by summing power levels in each 1 MHz band in linear power terms. The 1 MHz band power levels to be summed can be obtained by averaging, in linear power terms, power levels in each frequency bin across the 1 MHz.

TEST RESULTS

No non-compliance noted

Test Data

Test mode: IEEE 802.11a mode / 5180 ~ 5240MHz

Channel	Frequency (MHz)	Maximum Output Power (dBm)	Maximum Output Power (W)	Limit (dBm)
Low	5180	13.48	0.0223	24.00
Mid	5220	*13.49	0.0223	24.00
High	5240	13.32	0.0215	24.00

Test mode: IEEE 802.11n HT 20 MHz mode / 5180 ~ 5240MHz

Channel	Frequency (MHz)	Maximum Output Power (dBm)	Maximum Output Power (W)	Limit (dBm)
Low	5180	12.56	0.0180	24.00
Mid	5220	*13.17	0.0207	24.00
High	5240	13.11	0.0205	24.00

Test mode: IEEE 802.11n HT 40 MHz mode / 5190 ~ 5230MHz

Channel	Frequency (MHz)	Maximum Output Power (dBm)	Maximum Output Power (W)	Limit (dBm)
Low	5190	13.18	0.0208	24.00
High	5230	*13.28	0.0213	24.00

Test mode: IEEE 802.11a mode / 5260 ~ 5320MHz

Channel	Frequency (MHz)	Maximum Output Power (dBm)	Maximum Output Power (W)	Limit (dBm)
Low	5260	13.35	0.0216	24.00
Mid	5280	*13.46	0.0222	24.00
High	5320	13.10	0.0204	24.00

Test mode: IEEE 802.11n HT 20 MHz mode / 5260 ~ 5320MHz

Channel	Frequency (MHz)	Maximum Output Power (dBm)	Maximum Output Power (W)	Limit (dBm)
Low	5260	*13.37	0.0217	24.00
Mid	5280	13.04	0.0201	24.00
High	5320	13.08	0.0203	24.00

Test mode: IEEE 802.11n HT 40 MHz mode / 5270 ~ 5310MHz

Channel	Frequency (MHz)	Maximum Output Power (dBm)	Maximum Output Power (W)	Limit (dBm)
Low	5270	*13.48	0.0223	24.00
High	5310	12.55	0.0180	24.00

Test mode: IEEE 802.11a mode / 5500 ~ 5720MHz

Channel	Frequency (MHz)	Maximum Output Power (dBm)	Maximum Output Power (W)	Limit (dBm)
Low	5500	13.12	0.0205	24.00
Mid	5580	13.34	0.0216	24.00
High	5700	*13.38	0.0218	24.00

Test mode: IEEE 802.11n HT 20 MHz mode / 5500 ~ 5720MHz

Channel	Frequency (MHz)	Maximum Output Power (dBm)	Maximum Output Power (W)	Limit (dBm)
Low	5500	12.42	0.0175	24.00
Mid	5580	13.21	0.0209	24.00
High	5700	*13.28	0.0213	24.00

Test mode: IEEE 802.11n HT 40 MHz mode / 5510 ~ 5710MHz

Channel	Frequency (MHz)	Maximum Output Power (dBm)	Maximum Output Power (W)	Limit (dBm)
Low	5510	13.1	0.0204	24.00
Mid	5550	*13.33	0.0215	24.00
High	5670	13.28	0.0213	24.00

7.4 BAND EDGES MEASUREMENT

LIMIT

According to §15.407 & RSS-247 §, in any 100 kHz bandwidth outside the frequency bands in which the spread spectrum intentional radiator is operating, the radio frequency power that is produced by the intentional radiator shall be at least 20 dB below that in the 100 kHz bandwidth within the band that contains the highest level of the desired power, based on either an RF conducted or a radiated measurement, provided the transmitter demonstrates compliance with the peak conducted power limits. In addition, radiated emissions which fall in the restricted bands, as defined in §15.205(a), must also comply with the radiated emission limits specified in 15.209(a) (see Section 15.205(c)).

Test Configuration

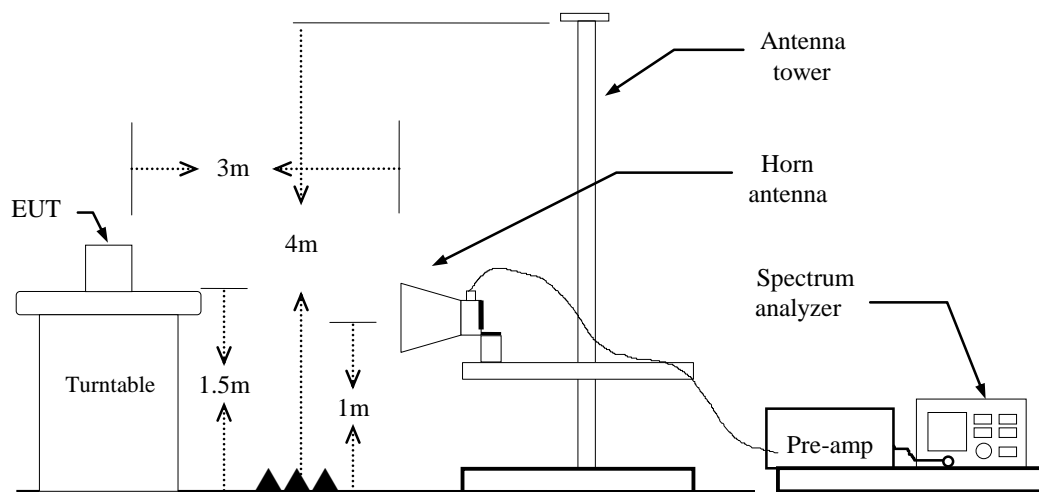

TEST PROCEDURE

1. The EUT is placed on a turntable, which is 1.5m above the ground plane.
2. The turntable shall be rotated for 360 degrees to determine the position of maximum emission level.
3. EUT is set 3m away from the receiving antenna, which is varied from 1m to 4m to find out the highest emission.
4. Set the spectrum analyzer in the following setting in order to capture the lower and upper band-edges of the emission:
 - (a) PEAK: RBW=VBW=1MHz / Sweep=AUTO
 - (b) AVERAGE: RBW=1MHz,
if duty cycle $\geq 98\%$, VBW=10Hz.
if duty cycle $< 98\%$ VBW=1/T.
IEEE 802.11a mode: $\geq 98\%$, VBW=10Hz
IEEE 802.11n HT 20 MHz mode: $\geq 98\%$, VBW=10Hz
IEEE 802.11n HT 40 MHz mode: $\geq 98\%$, VBW=10Hz
5. Repeat the procedures until all the PEAK and AVERAGE versus POLARIZATION are measured.
6. Result = Spectrum Reading + cable loss(spectrum to Amp) - Amp Gain + Cable loss(Amp to receive Ant)+ Receive Ant

For Un-restricted Band Emissions

The peak output power procedure is used to measure the fundamental emission power to demonstrate compliance to requirements, then the peak conducted output power measured within any 100 kHz outside the authorized frequency band shall be attenuated by at least 20 dB relative to the maximum measured in-band peak PSD level.

TEST RESULTS

Refer to attach spectrum analyzer data chart.

U-NII-1

IEEE 802.11a Mode / CH Low

Detector mode: Peak

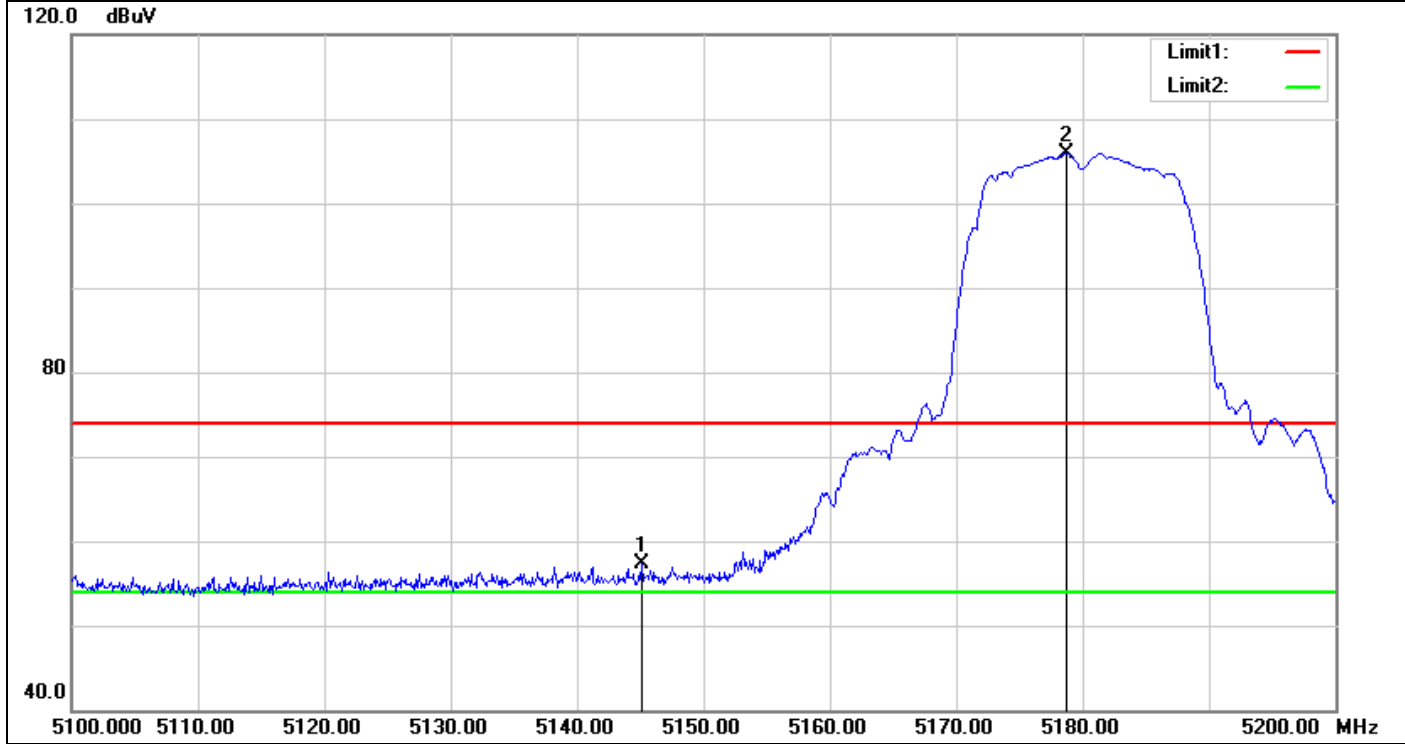

No.	Frequency (MHz)	Reading (dBuV)	Correct Factor(dB)	Result (dBuV)	Limit (dBuV)	Margin (dB)	Remark
1	5145.100	54.28	3.01	57.29	74.00	-16.71	peak
2	5178.700	102.04	3.87	105.91	74.00	31.91	peak

Detector mode: Average

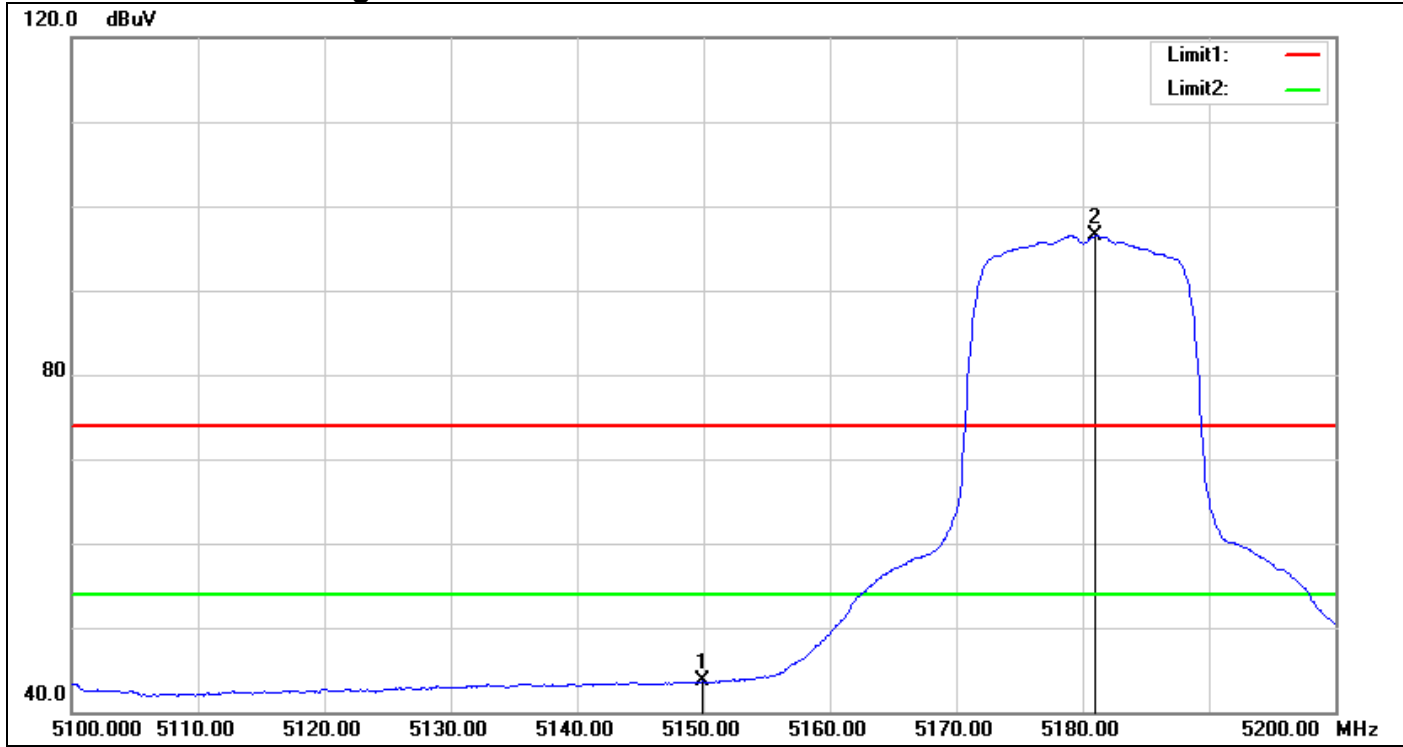

No.	Frequency (MHz)	Reading (dBuV)	Correct Factor(dB)	Result (dBuV)	Limit (dBuV)	Margin (dB)	Remark
1	5149.900	40.57	3.04	43.61	54.00	-10.39	AVG
2	5181.000	92.59	3.94	96.53	54.00	42.53	AVG

IEEE 802.11a Mode / CH Mid

Detector mode: Peak

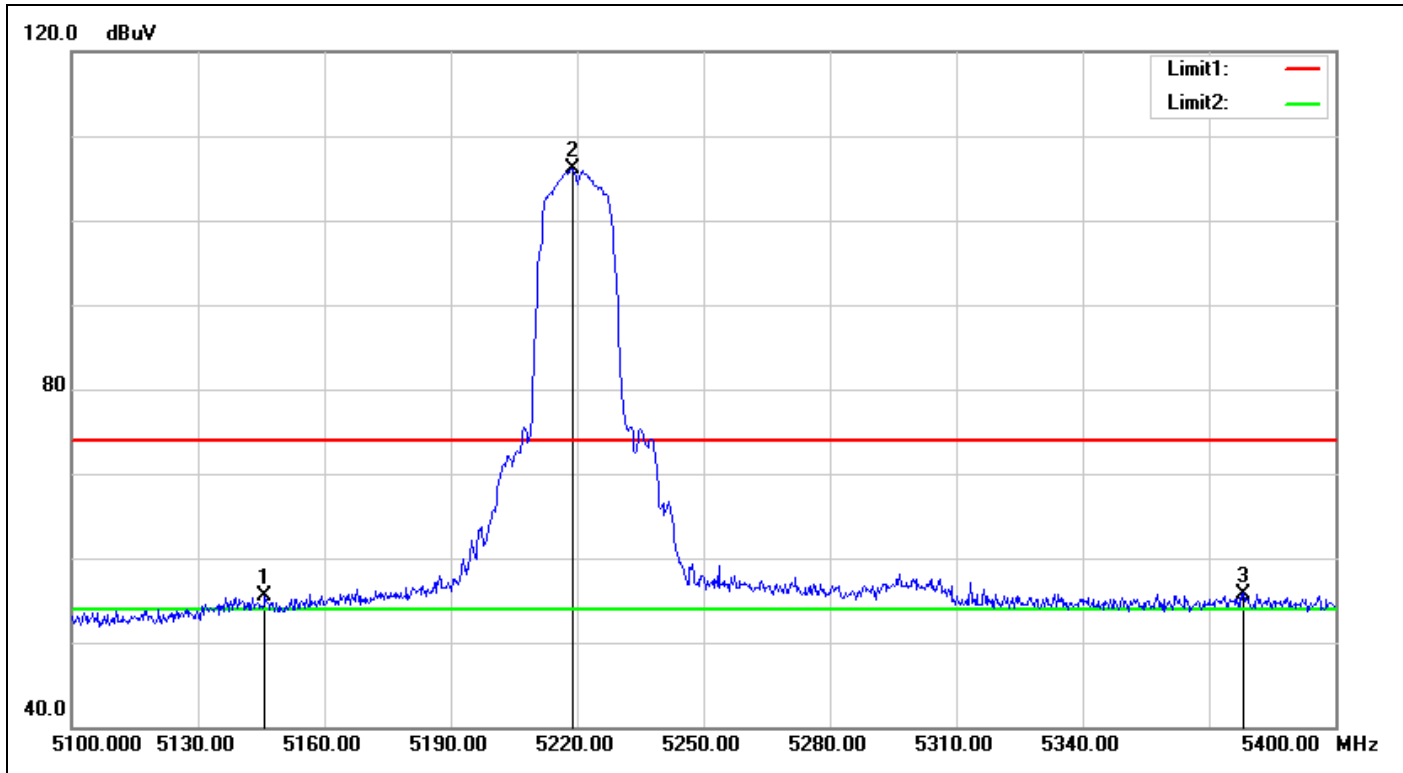

No.	Frequency (MHz)	Reading (dBuV)	Correct Factor(dB)	Result (dBuV)	Limit (dBuV)	Margin (dB)	Remark
1	5145.900	52.57	3.01	55.58	74.00	-18.42	peak
2	5218.800	101.57	4.55	106.12	74.00	32.12	peak
3	5378.100	50.26	5.54	55.80	74.00	-18.20	peak

Detector mode: Average

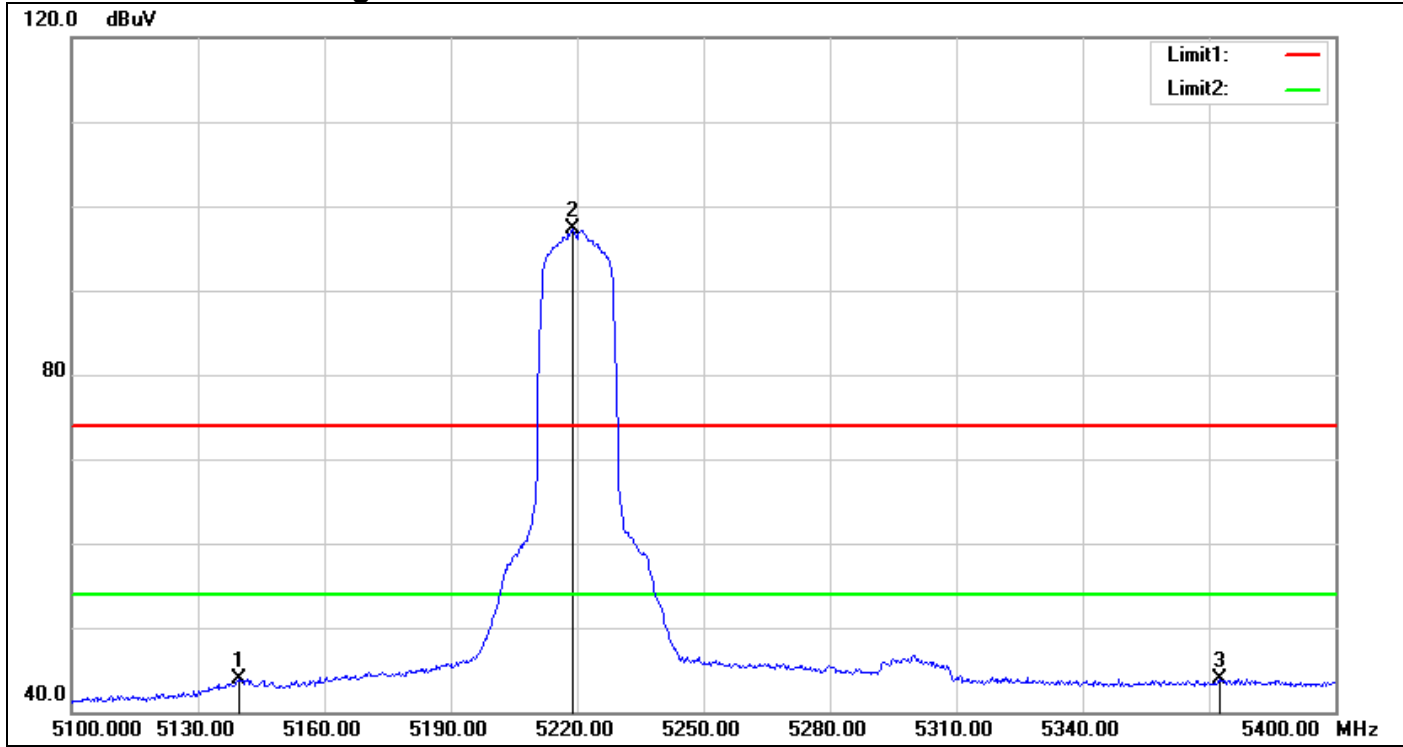

No.	Frequency (MHz)	Reading (dBuV)	Correct Factor(dB)	Result (dBuV)	Limit (dBuV)	Margin (dB)	Remark
1	5139.900	40.98	2.97	43.95	54.00	-10.05	AVG
2	5218.800	92.82	4.55	97.37	54.00	43.37	AVG
3	5372.400	38.35	5.49	43.84	54.00	-10.16	AVG

IEEE 802.11a Mode / CH High

Detector mode: Peak

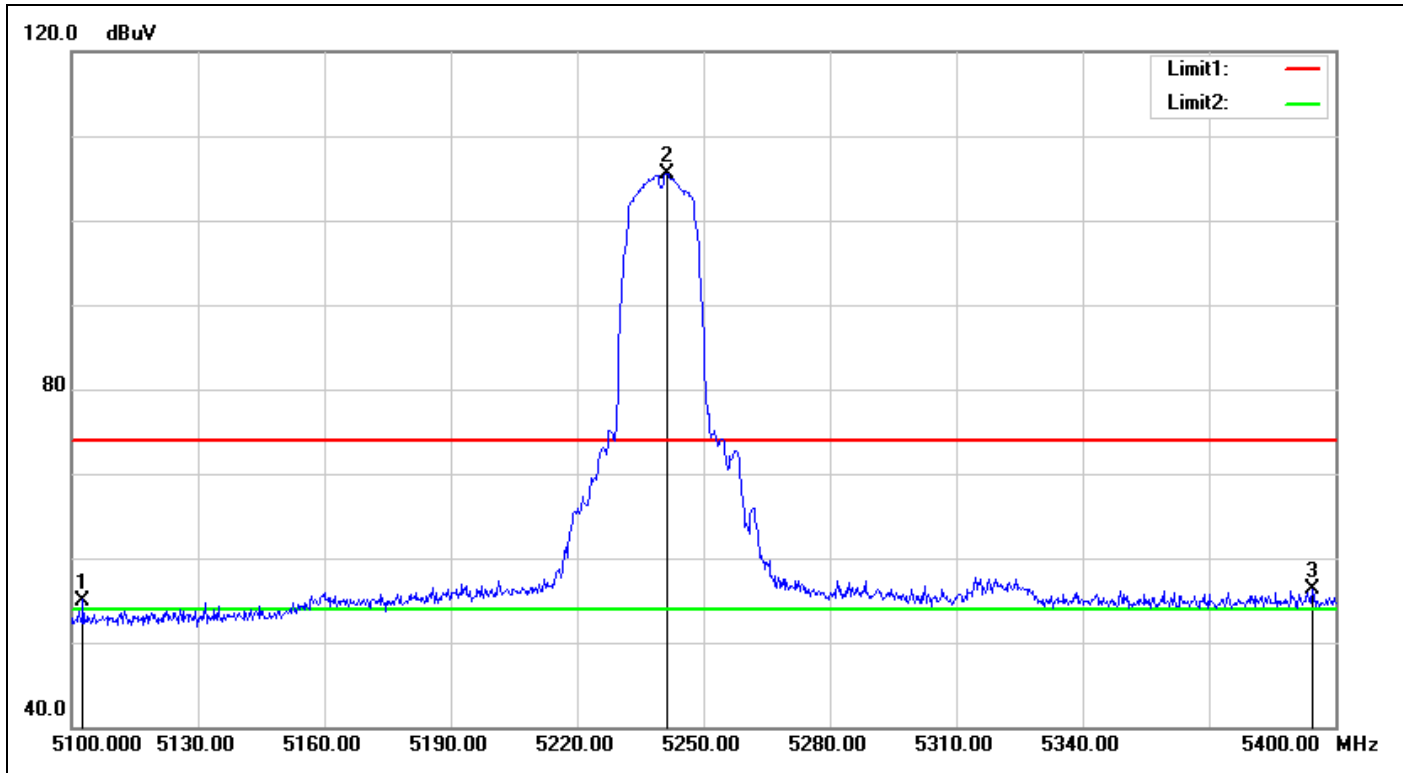

No.	Frequency (MHz)	Reading (dBuV)	Correct Factor(dB)	Result (dBuV)	Limit (dBuV)	Margin (dB)	Remark
1	5102.700	52.28	2.72	55.00	74.00	-19.00	peak
2	5241.300	100.94	4.63	105.57	74.00	31.57	peak
3	5394.600	50.60	5.68	56.28	74.00	-17.72	peak

Detector mode: Average

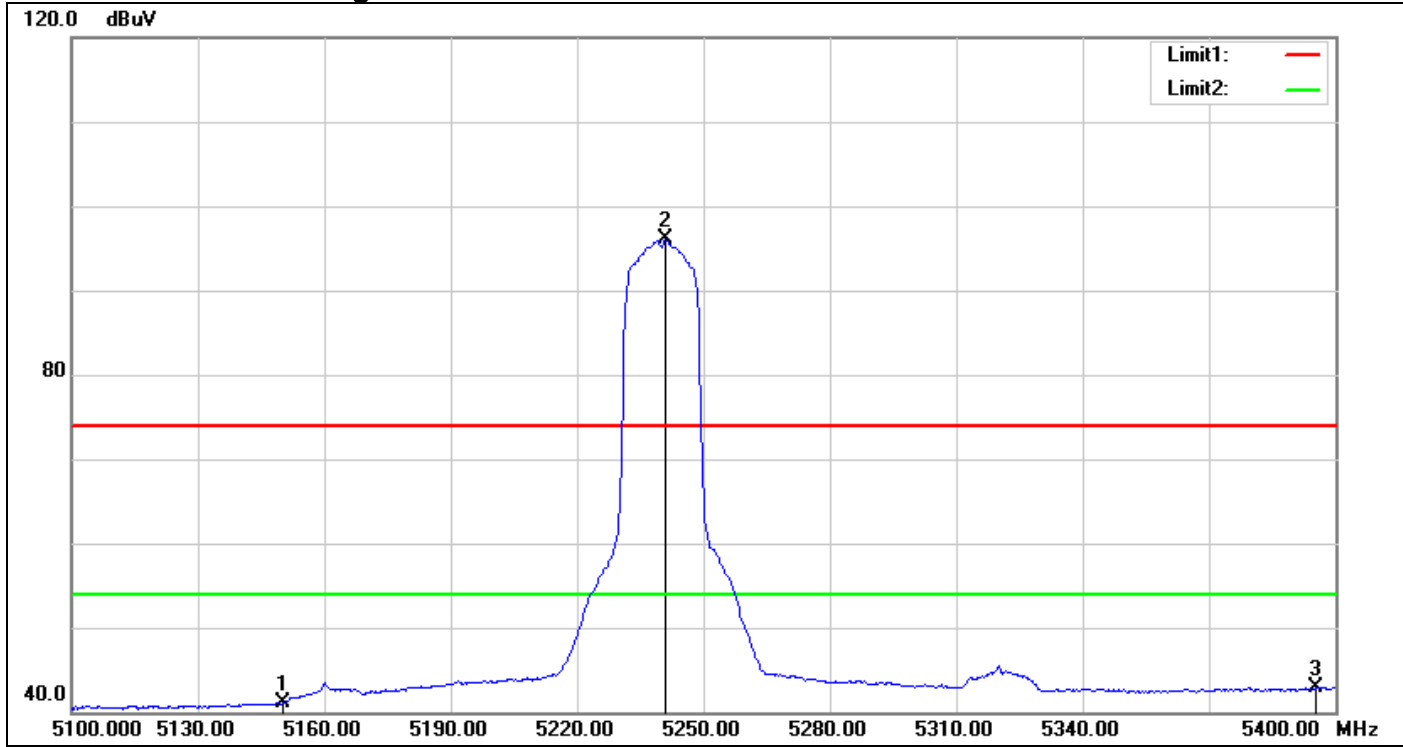

No.	Frequency (MHz)	Reading (dBuV)	Correct Factor(dB)	Result (dBuV)	Limit (dBuV)	Margin (dB)	Remark
1	5150.000	38.06	3.04	41.10	54.00	-12.90	AVG
2	5241.000	91.40	4.63	96.03	54.00	42.03	AVG
3	5395.500	37.23	5.68	42.91	54.00	-11.09	AVG

IEEE 802.11n HT20 MHz Mode / CH Low

Detector mode: Peak

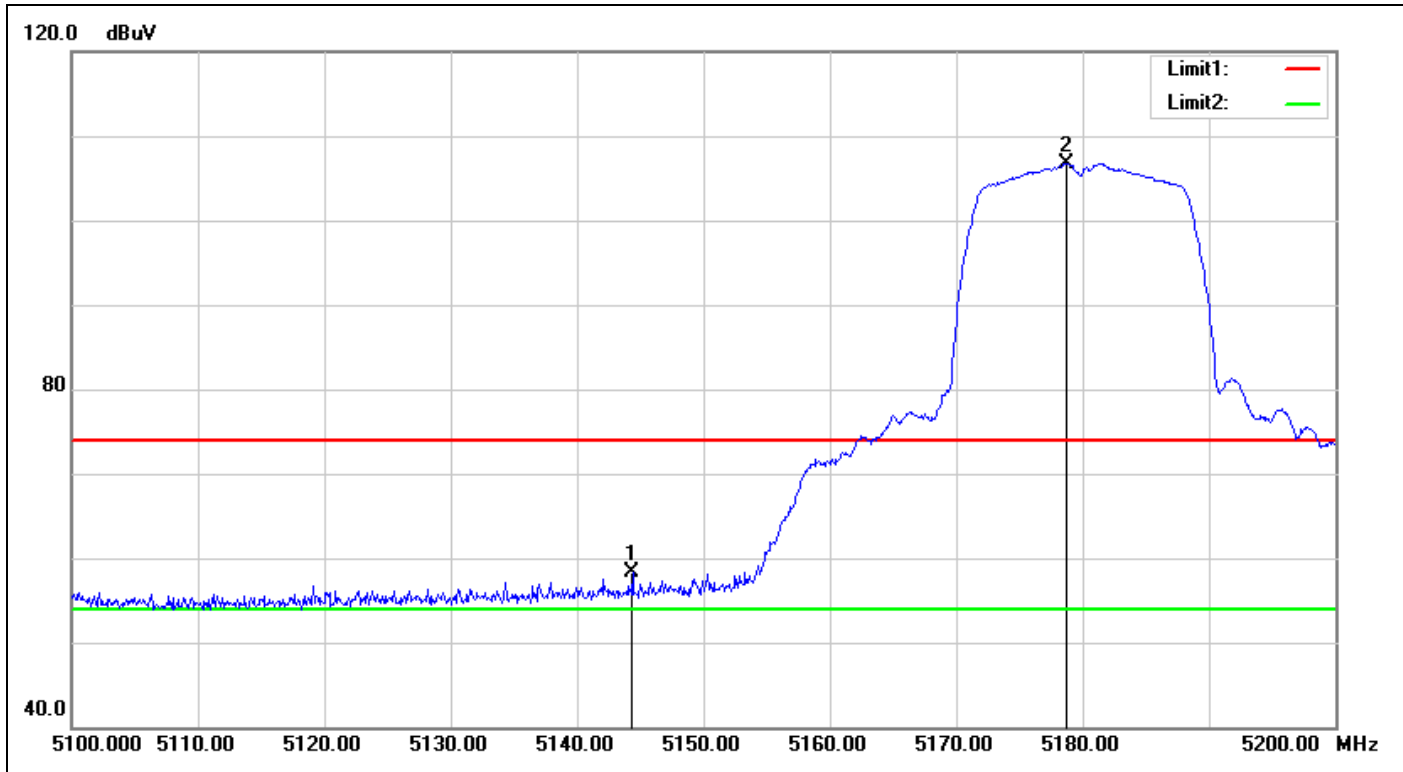

No.	Frequency (MHz)	Reading (dBuV)	Correct Factor(dB)	Result (dBuV)	Limit (dBuV)	Margin (dB)	Remark
1	5144.400	55.25	3.00	58.25	74.00	-15.75	peak
2	5178.700	102.91	3.87	106.78	74.00	32.78	peak

Detector mode: Average

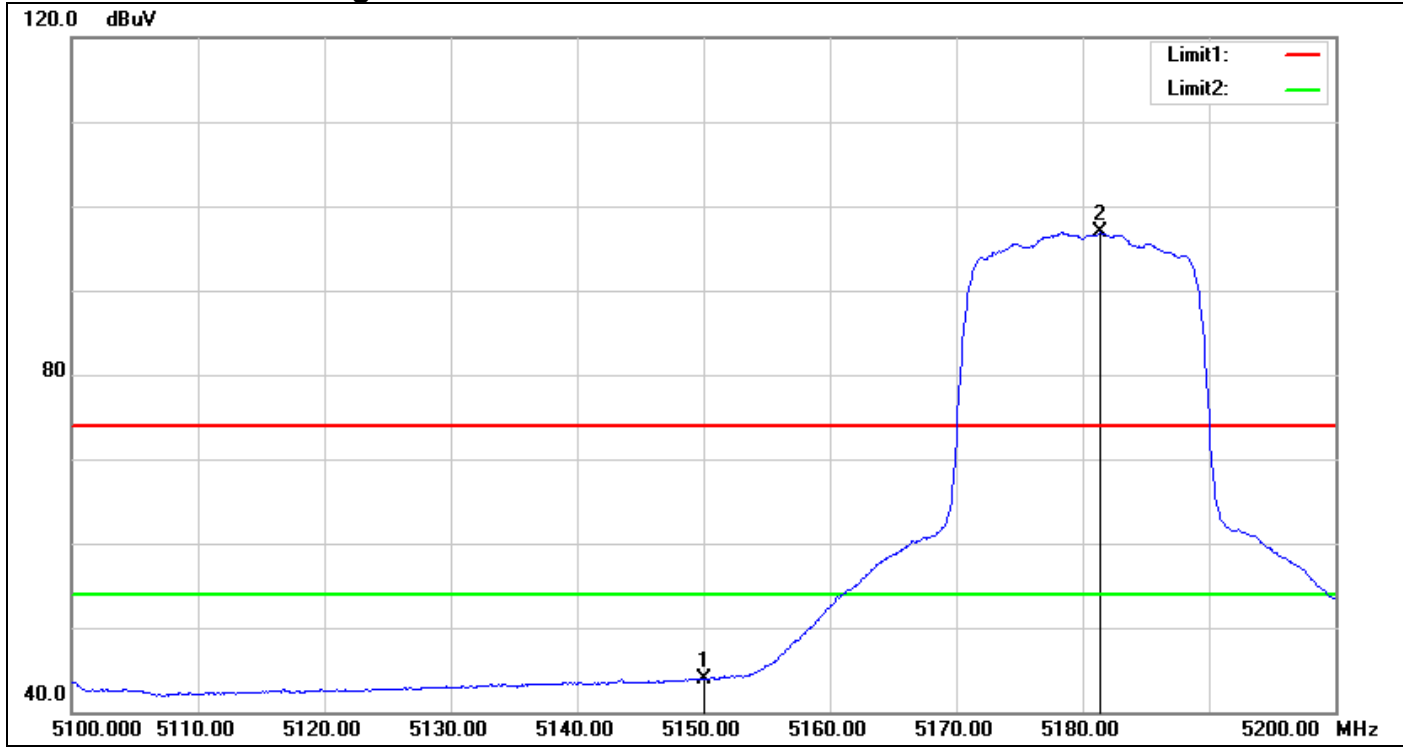

No.	Frequency (MHz)	Reading (dBuV)	Correct Factor(dB)	Result (dBuV)	Limit (dBuV)	Margin (dB)	Remark
1	5150.000	40.85	3.04	43.89	54.00	-10.11	AVG
2	5181.400	92.97	3.95	96.92	54.00	42.92	AVG

IEEE 802.11n HT20 MHz Mode / CH Mid

Detector mode: Peak

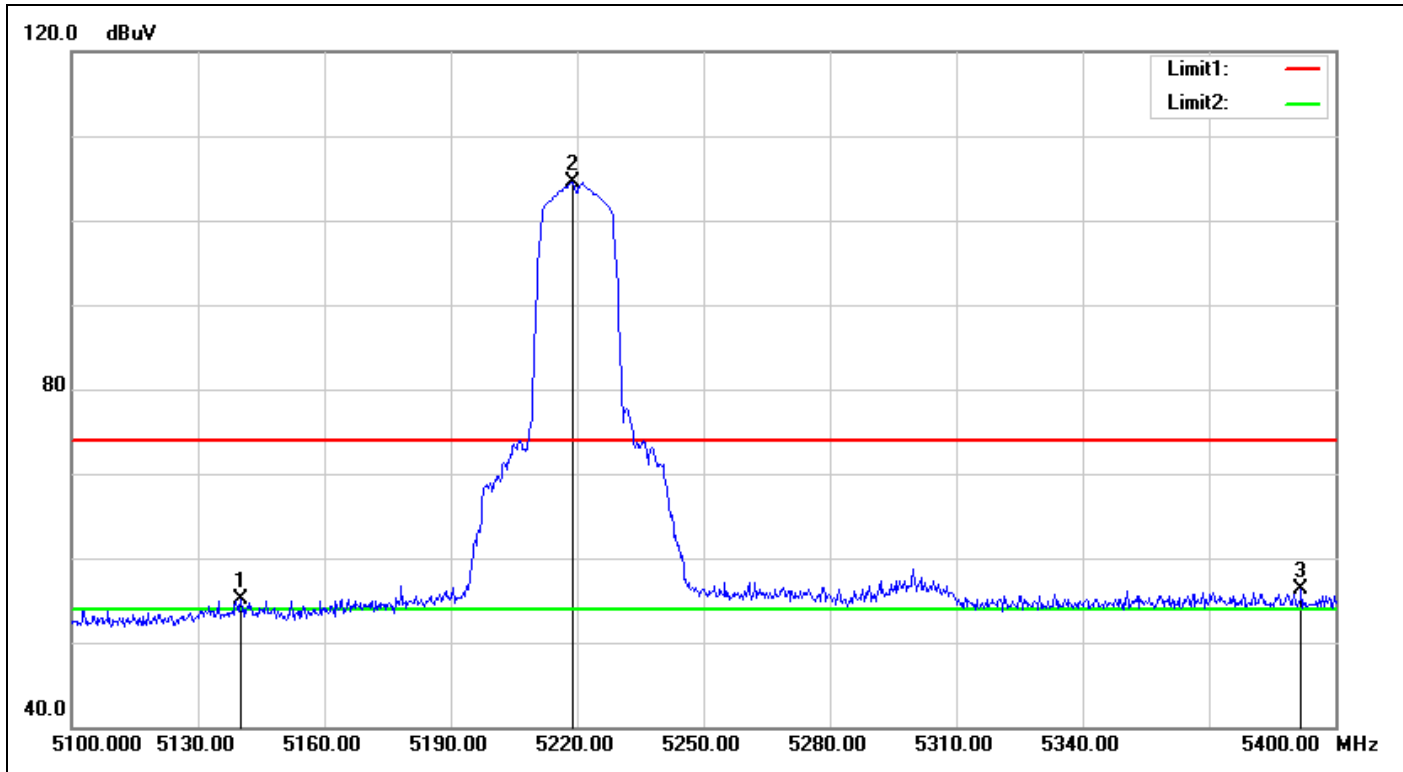

No.	Frequency (MHz)	Reading (dBuV)	Correct Factor(dB)	Result (dBuV)	Limit (dBuV)	Margin (dB)	Remark
1	5140.200	52.05	2.97	55.02	74.00	-18.98	peak
2	5218.800	100.00	4.55	104.55	74.00	30.55	peak
3	5391.900	50.65	5.65	56.30	74.00	-17.70	peak

Detector mode: Average

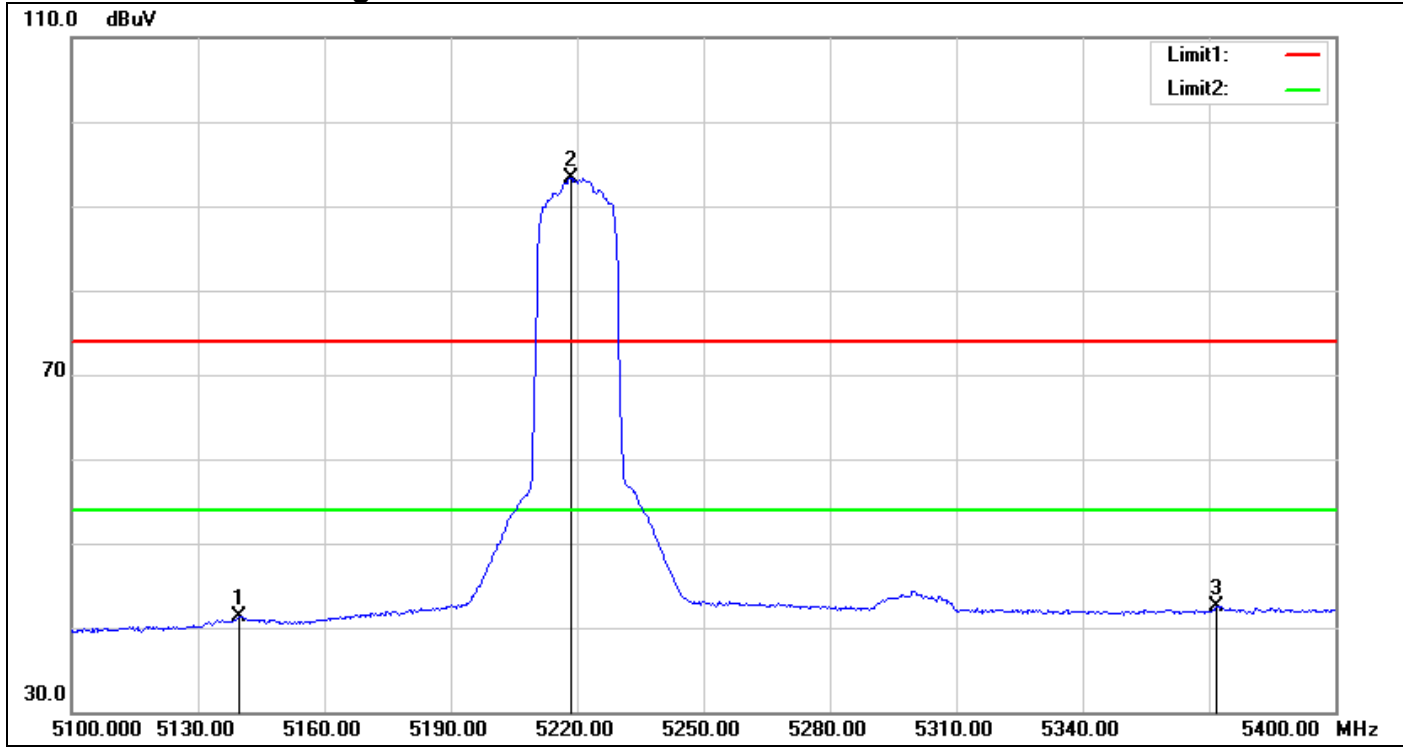

No.	Frequency (MHz)	Reading (dBuV)	Correct Factor(dB)	Result (dBuV)	Limit (dBuV)	Margin (dB)	Remark
1	5139.900	38.43	2.97	41.40	54.00	-12.60	AVG
2	5218.500	88.73	4.55	93.28	54.00	39.28	AVG
3	5371.800	36.96	5.49	42.45	54.00	-11.55	AVG

IEEE 802.11n HT20 MHz Mode / CH High

Detector mode: Peak

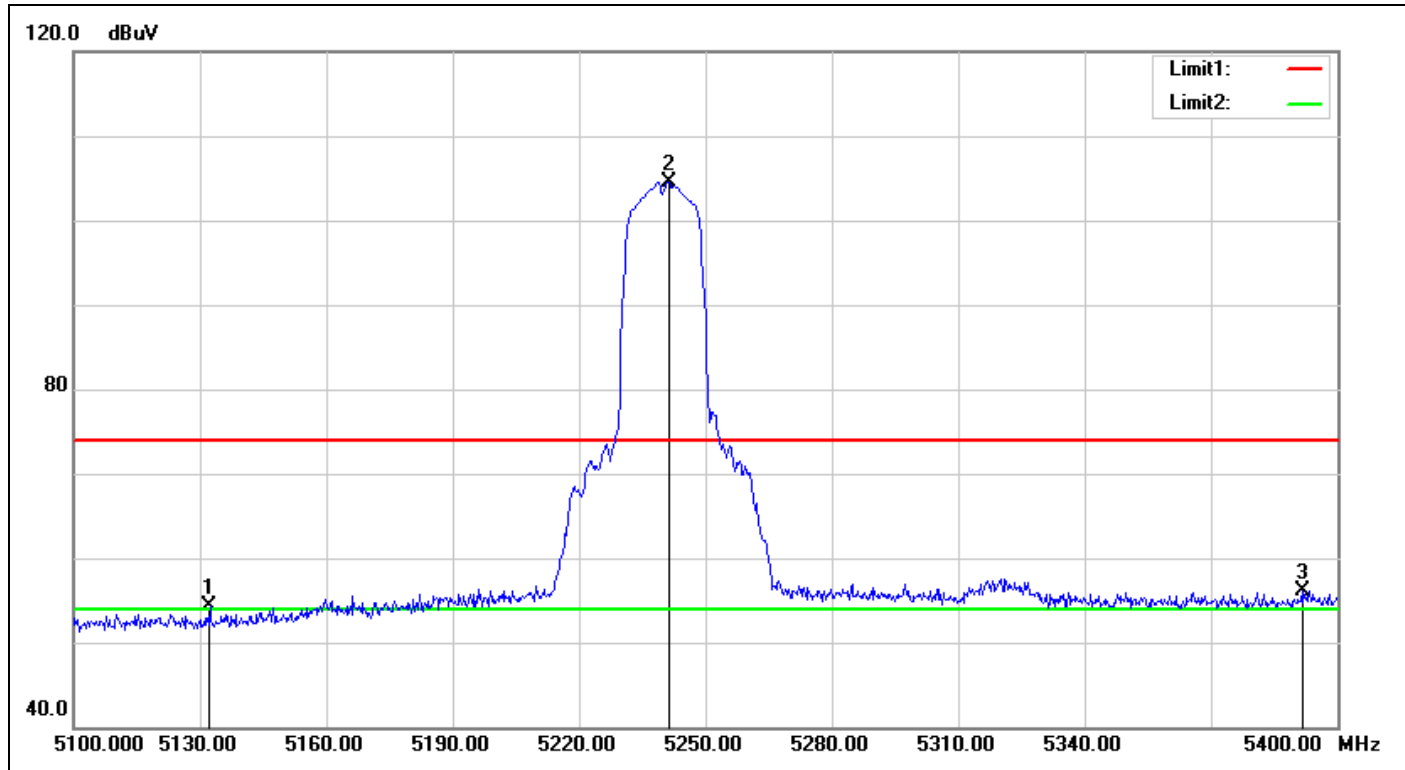

No.	Frequency (MHz)	Reading (dBuV)	Correct Factor(dB)	Result (dBuV)	Limit (dBuV)	Margin (dB)	Remark
1	5132.400	51.29	2.92	54.21	74.00	-19.79	peak
2	5241.300	99.87	4.63	104.50	74.00	30.50	peak
3	5391.600	50.51	5.65	56.16	74.00	-17.84	peak

Detector mode: Average

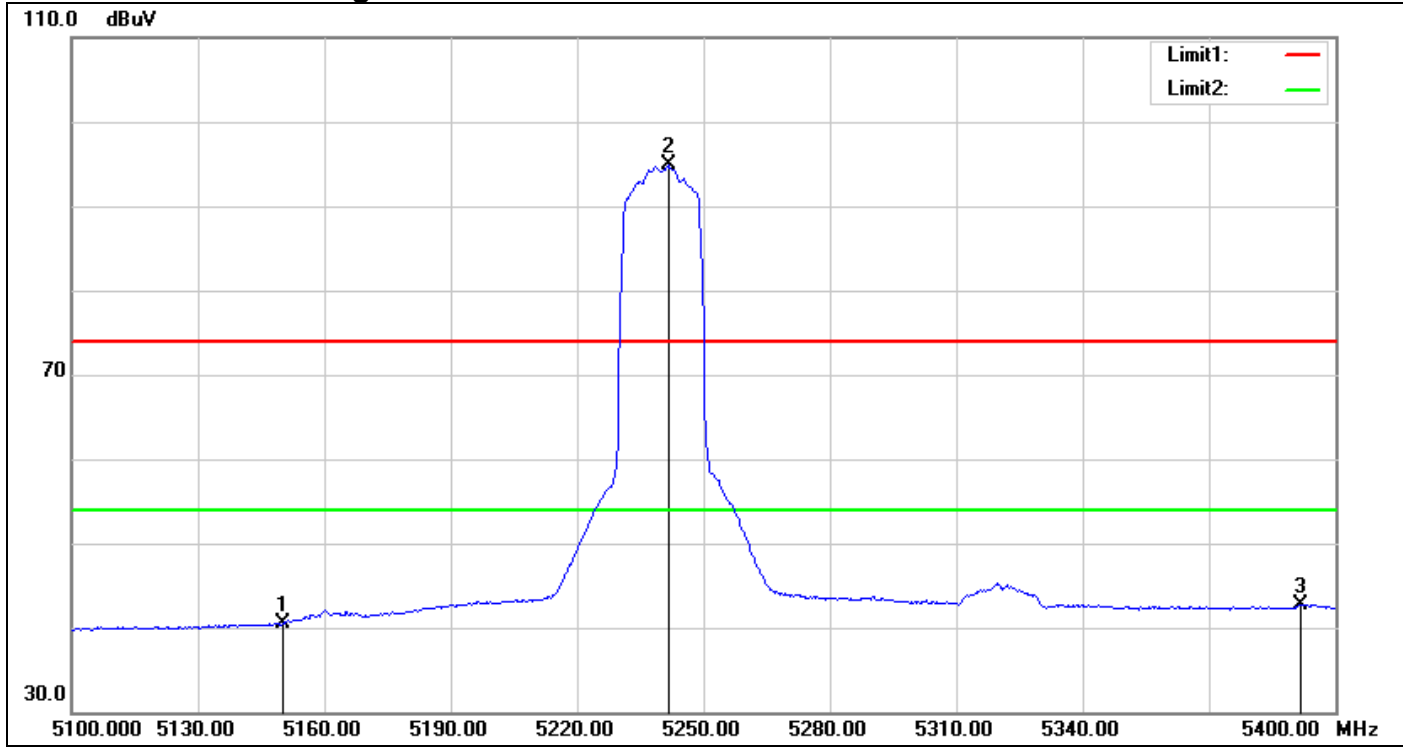

No.	Frequency (MHz)	Reading (dBuV)	Correct Factor(dB)	Result (dBuV)	Limit (dBuV)	Margin (dB)	Remark
1	5150.000	37.49	3.04	40.53	54.00	-13.47	AVG
2	5241.600	90.18	4.63	94.81	54.00	40.81	AVG
3	5391.600	37.12	5.65	42.77	54.00	-11.23	AVG

IEEE 802.11n HT40 MHz Mode / CH Low

Detector mode: Peak

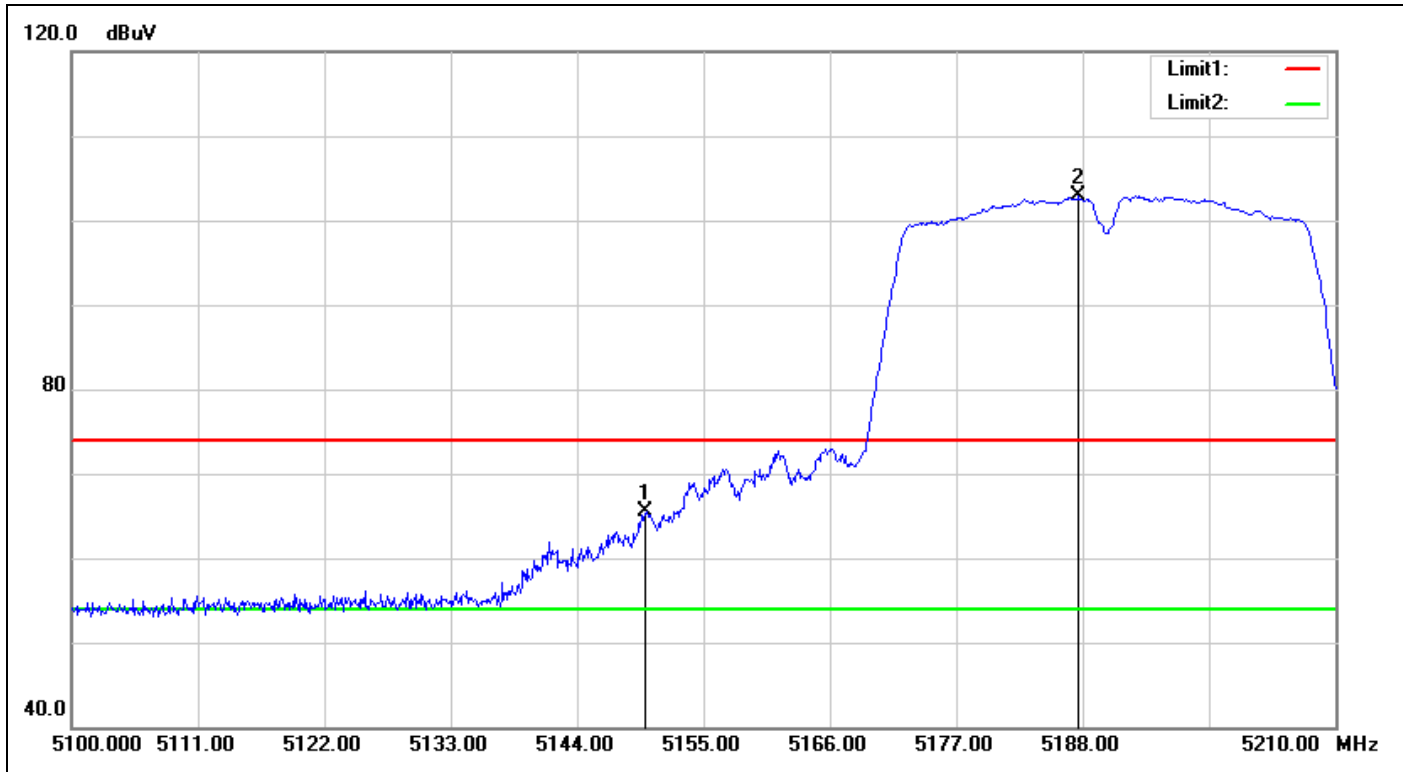

No.	Frequency (MHz)	Reading (dBuV)	Correct Factor(dB)	Result (dBuV)	Limit (dBuV)	Margin (dB)	Remark
1	5150.000	62.47	3.04	65.51	74.00	-8.49	peak
2	5187.670	98.84	4.13	102.97	74.00	28.97	peak

Detector mode: Average

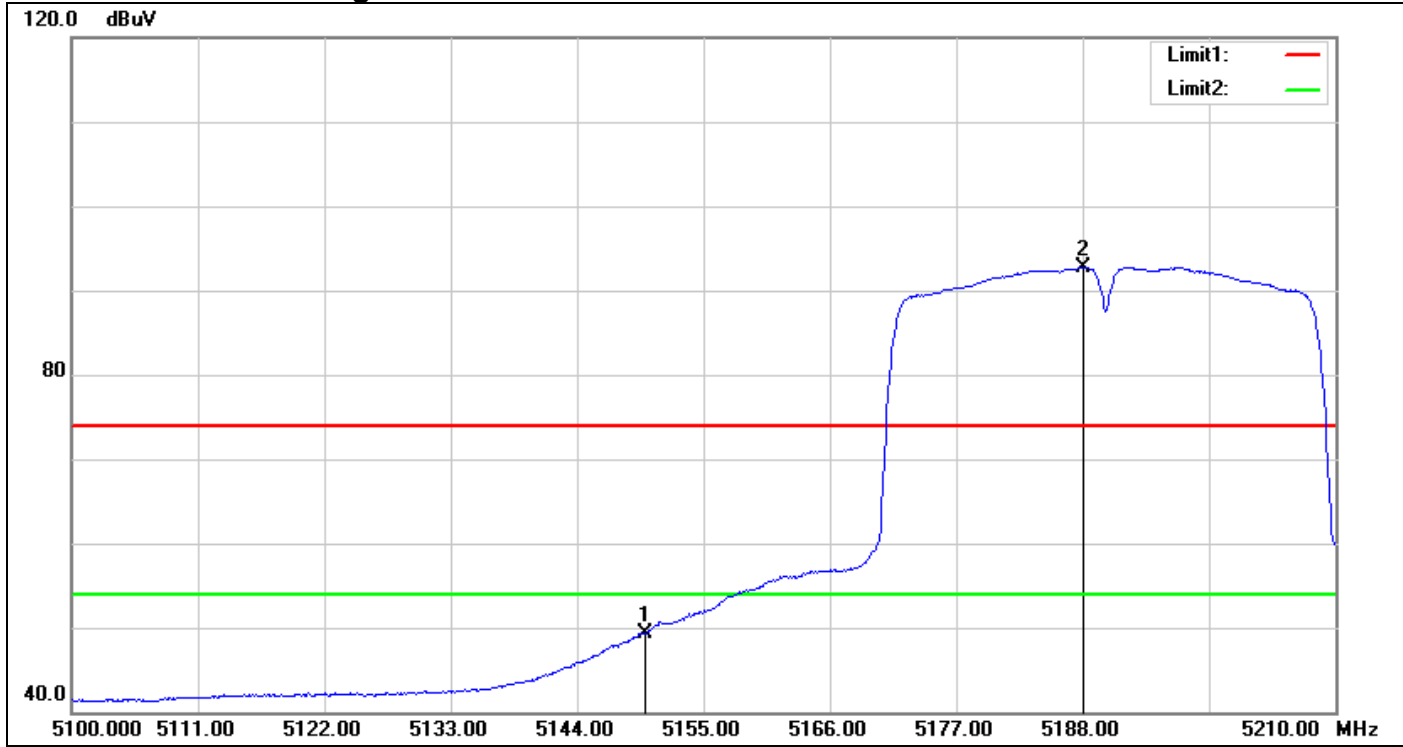

No.	Frequency (MHz)	Reading (dBuV)	Correct Factor(dB)	Result (dBuV)	Limit (dBuV)	Margin (dB)	Remark
1	5150.000	46.33	3.04	49.37	54.00	-4.63	AVG
2	5188.110	88.58	4.15	92.73	54.00	38.73	AVG

IEEE 802.11n HT40 MHz Mode / CH High

Detector mode: Peak

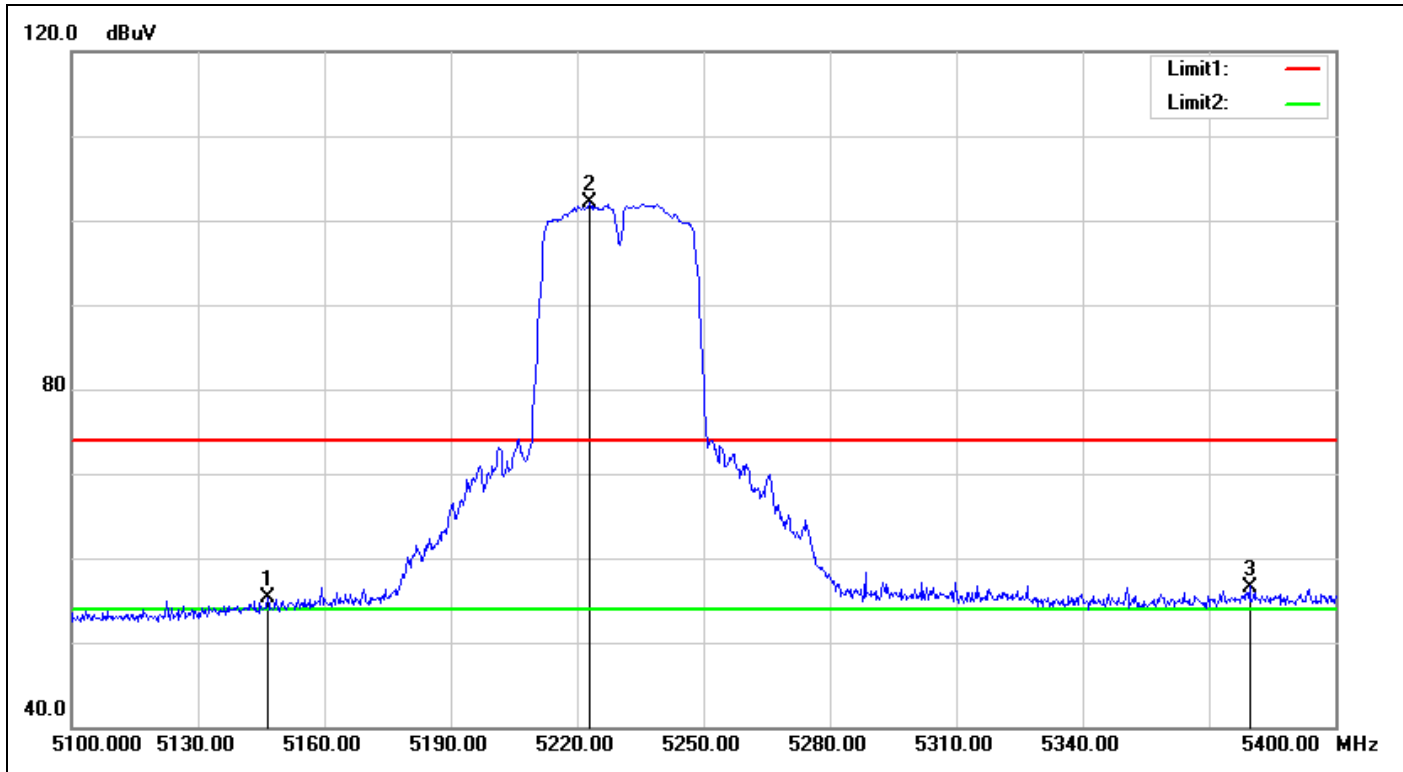

No.	Frequency (MHz)	Reading (dBuV)	Correct Factor(dB)	Result (dBuV)	Limit (dBuV)	Margin (dB)	Remark
1	5146.500	52.28	3.02	55.30	74.00	-18.70	peak
2	5223.000	97.44	4.57	102.01	74.00	28.01	peak
3	5379.600	51.05	5.55	56.60	74.00	-17.40	peak

Detector mode: Average

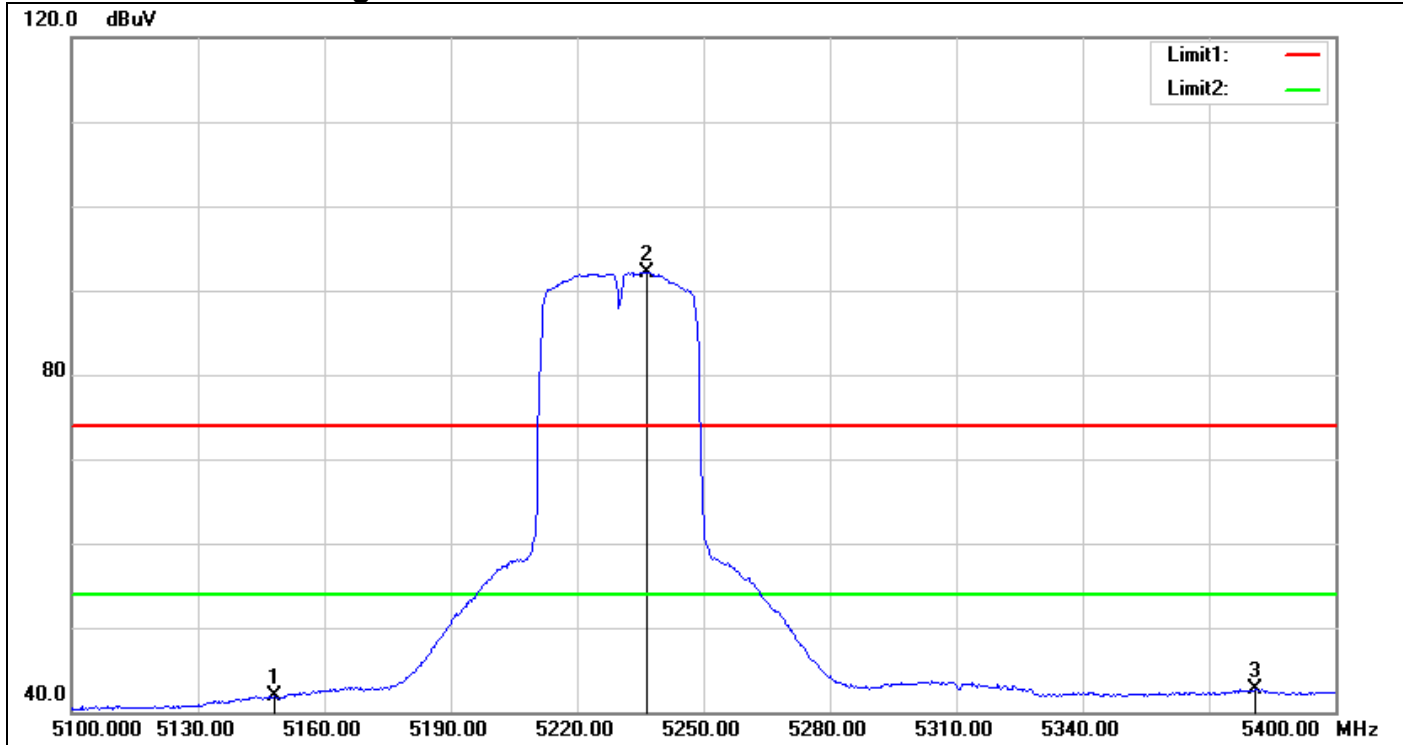

No.	Frequency (MHz)	Reading (dBuV)	Correct Factor(dB)	Result (dBuV)	Limit (dBuV)	Margin (dB)	Remark
1	5148.300	38.89	3.03	41.92	54.00	-12.08	AVG
2	5236.500	87.58	4.61	92.19	54.00	38.19	AVG
3	5381.100	37.17	5.57	42.74	54.00	-11.26	AVG

U-NII-2A

IEEE 802.11a Mode / CH Low

Detector mode: Peak

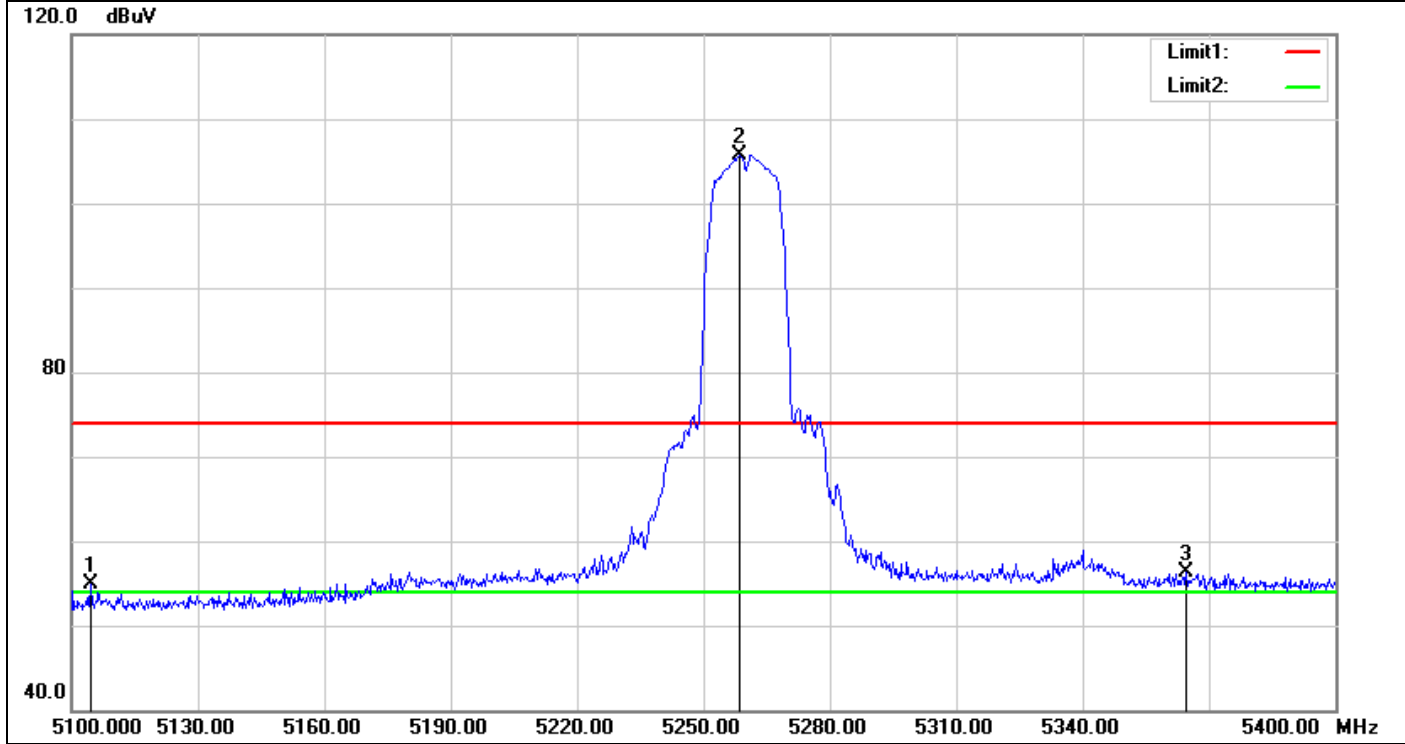

No.	Frequency (MHz)	Reading (dBuV)	Correct Factor(dB)	Result (dBuV)	Limit (dBuV)	Margin (dB)	Remark
1	5104.500	52.12	2.73	54.85	74.00	-19.15	peak
2	5258.700	101.08	4.69	105.77	74.00	31.77	peak
3	5364.600	50.93	5.43	56.36	74.00	-17.64	peak

Detector mode: Average

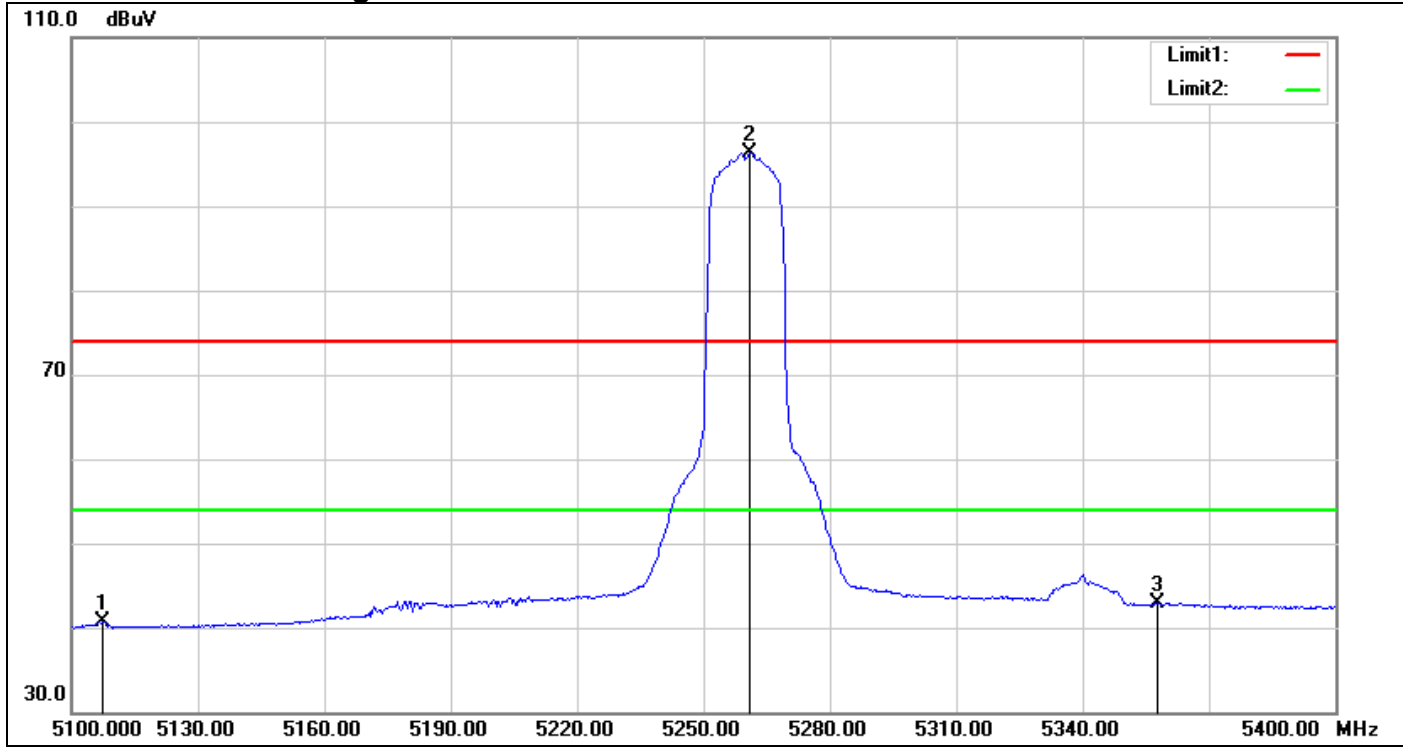

No.	Frequency (MHz)	Reading (dBuV)	Correct Factor(dB)	Result (dBuV)	Limit (dBuV)	Margin (dB)	Remark
1	5107.200	37.98	2.75	40.73	54.00	-13.27	AVG
2	5261.100	91.67	4.70	96.37	54.00	42.37	AVG
3	5357.700	37.56	5.37	42.93	54.00	-11.07	AVG

IEEE 802.11a Mode / CH Mid

Detector mode: Peak

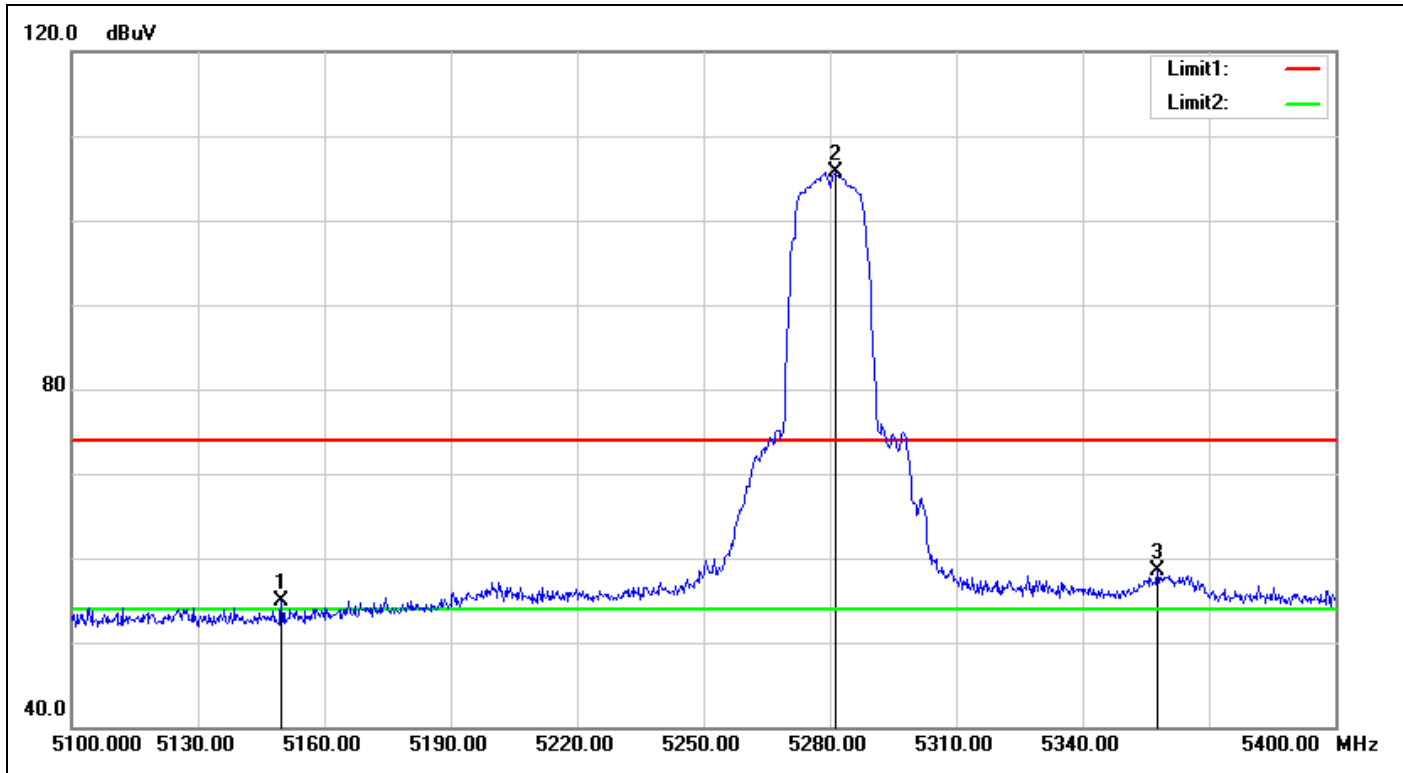

No.	Frequency (MHz)	Reading (dBuV)	Correct Factor(dB)	Result (dBuV)	Limit (dBuV)	Margin (dB)	Remark
1	5149.800	51.83	3.04	54.87	74.00	-19.13	peak
2	5281.500	100.92	4.77	105.69	74.00	31.69	peak
3	5357.700	53.11	5.37	58.48	74.00	-15.52	peak

Detector mode: Average

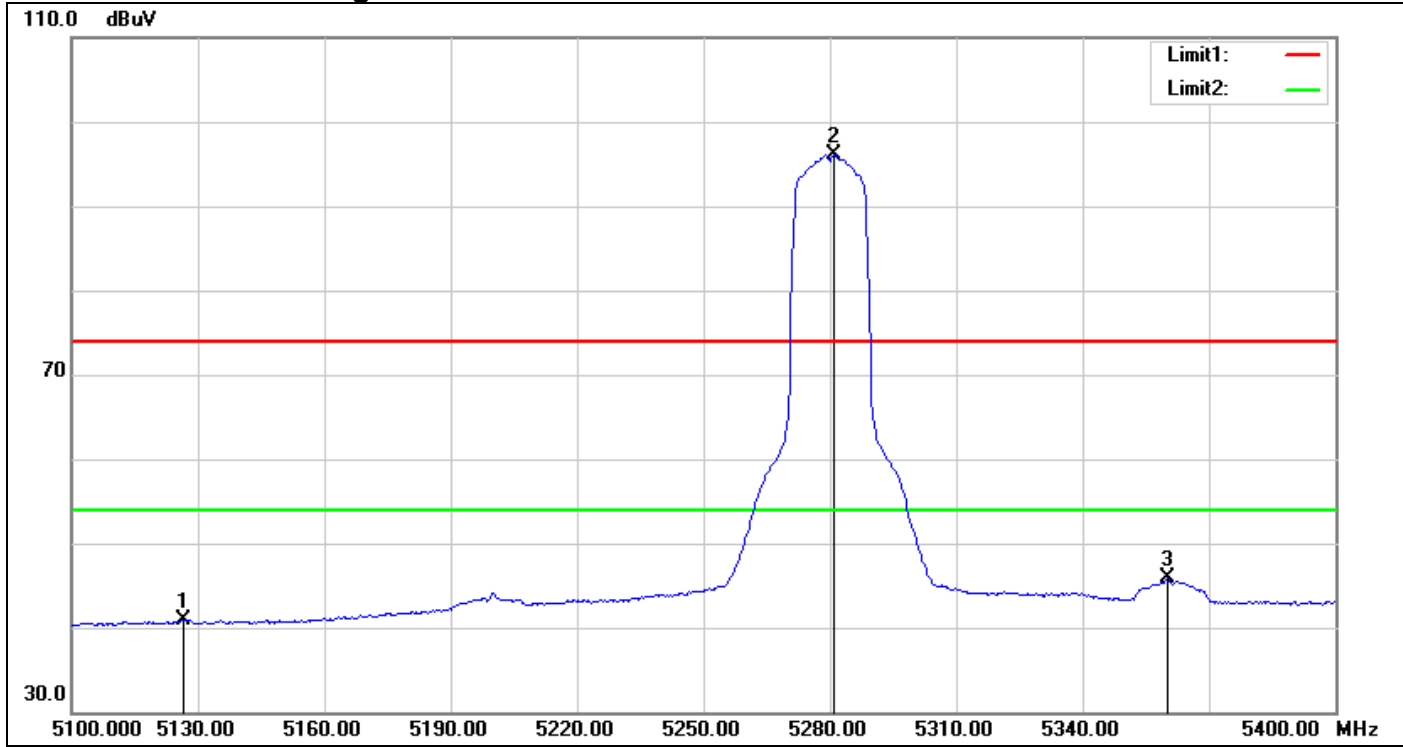

No.	Frequency (MHz)	Reading (dBuV)	Correct Factor(dB)	Result (dBuV)	Limit (dBuV)	Margin (dB)	Remark
1	5126.400	38.08	2.88	40.96	54.00	-13.04	AVG
2	5280.900	91.36	4.77	96.13	54.00	42.13	AVG
3	5360.100	40.51	5.39	45.90	54.00	-8.10	AVG

IEEE 802.11a Mode / CH High

Detector mode: Peak

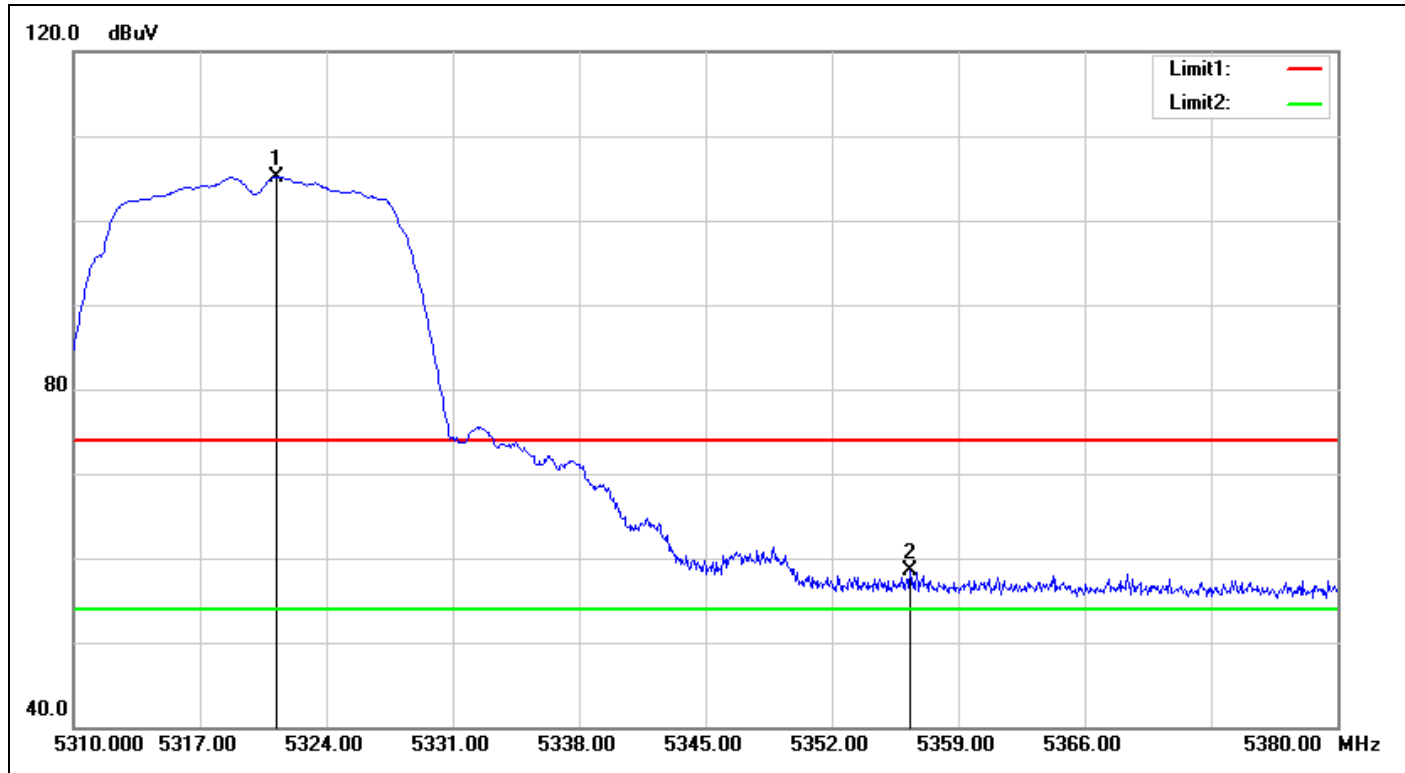

No.	Frequency (MHz)	Reading (dBuV)	Correct Factor(dB)	Result (dBuV)	Limit (dBuV)	Margin (dB)	Remark
1	5321.270	100.12	5.03	105.15	74.00	31.15	peak
2	5356.340	53.12	5.36	58.48	74.00	-15.52	peak

Detector mode: Average

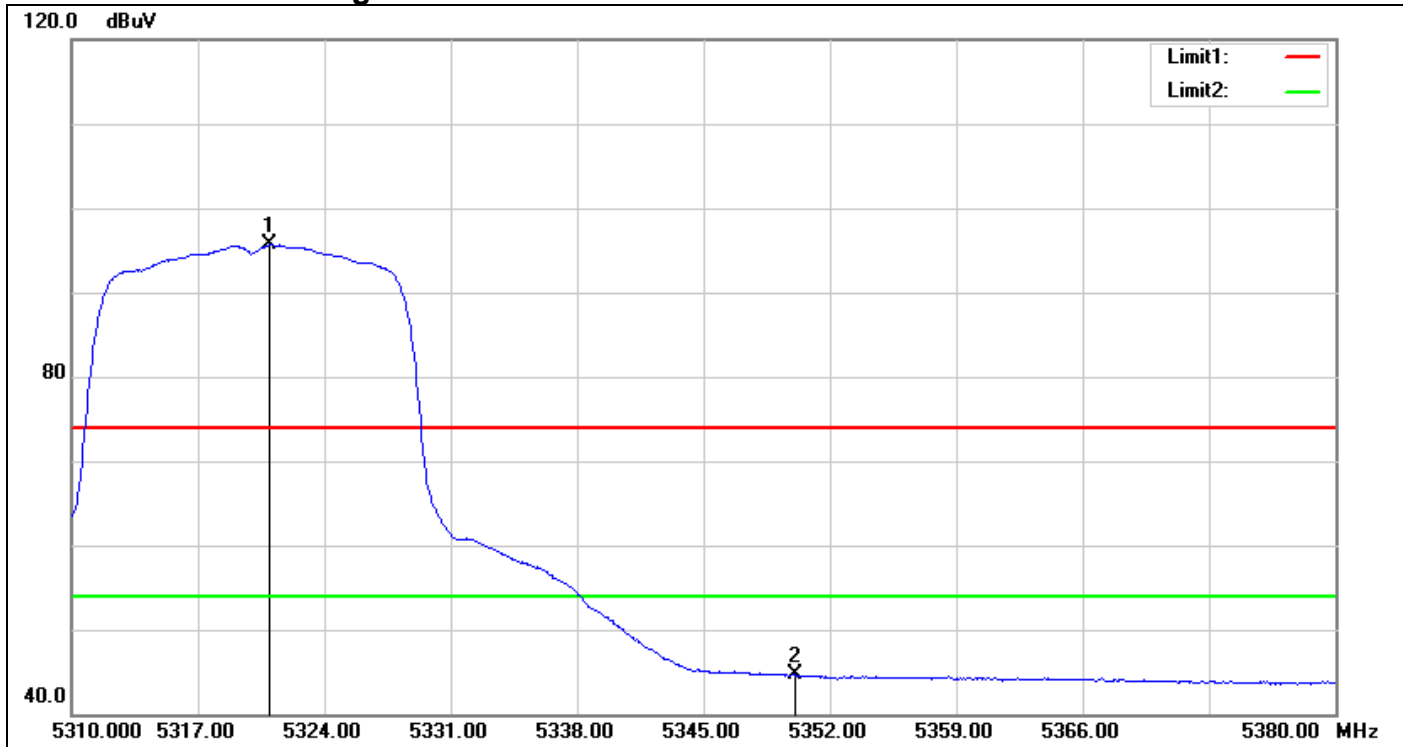

No.	Frequency (MHz)	Reading (dBuV)	Correct Factor(dB)	Result (dBuV)	Limit (dBuV)	Margin (dB)	Remark
1	5320.920	90.66	5.03	95.69	54.00	41.69	AVG
2	5350.040	39.43	5.31	44.74	54.00	-9.26	AVG

IEEE 802.11n HT20 MHz Mode / CH Low

Detector mode: Peak

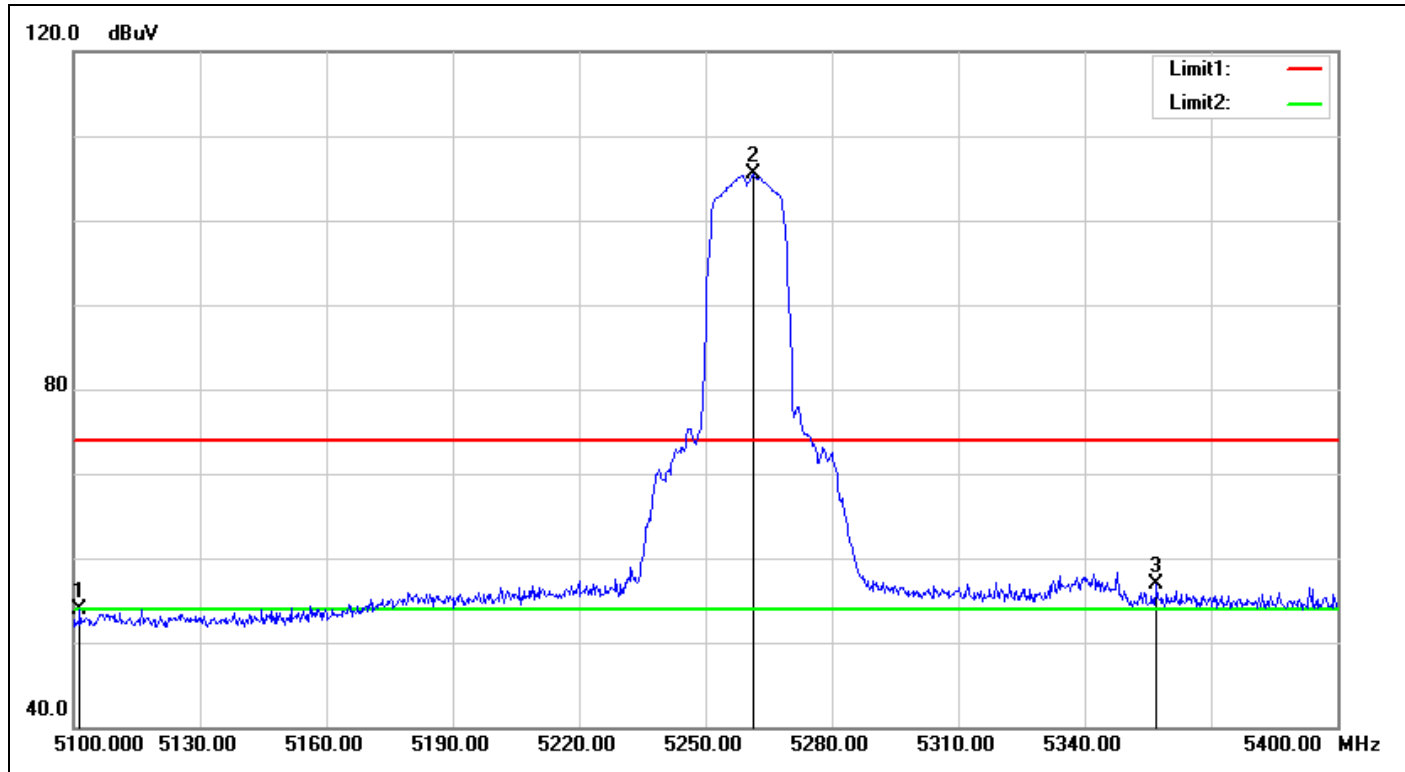

No.	Frequency (MHz)	Reading (dBuV)	Correct Factor(dB)	Result (dBuV)	Limit (dBuV)	Margin (dB)	Remark
1	5101.500	51.20	2.71	53.91	74.00	-20.09	peak
2	5261.400	100.76	4.70	105.46	74.00	31.46	peak
3	5357.100	51.59	5.37	56.96	74.00	-17.04	peak

Detector mode: Average

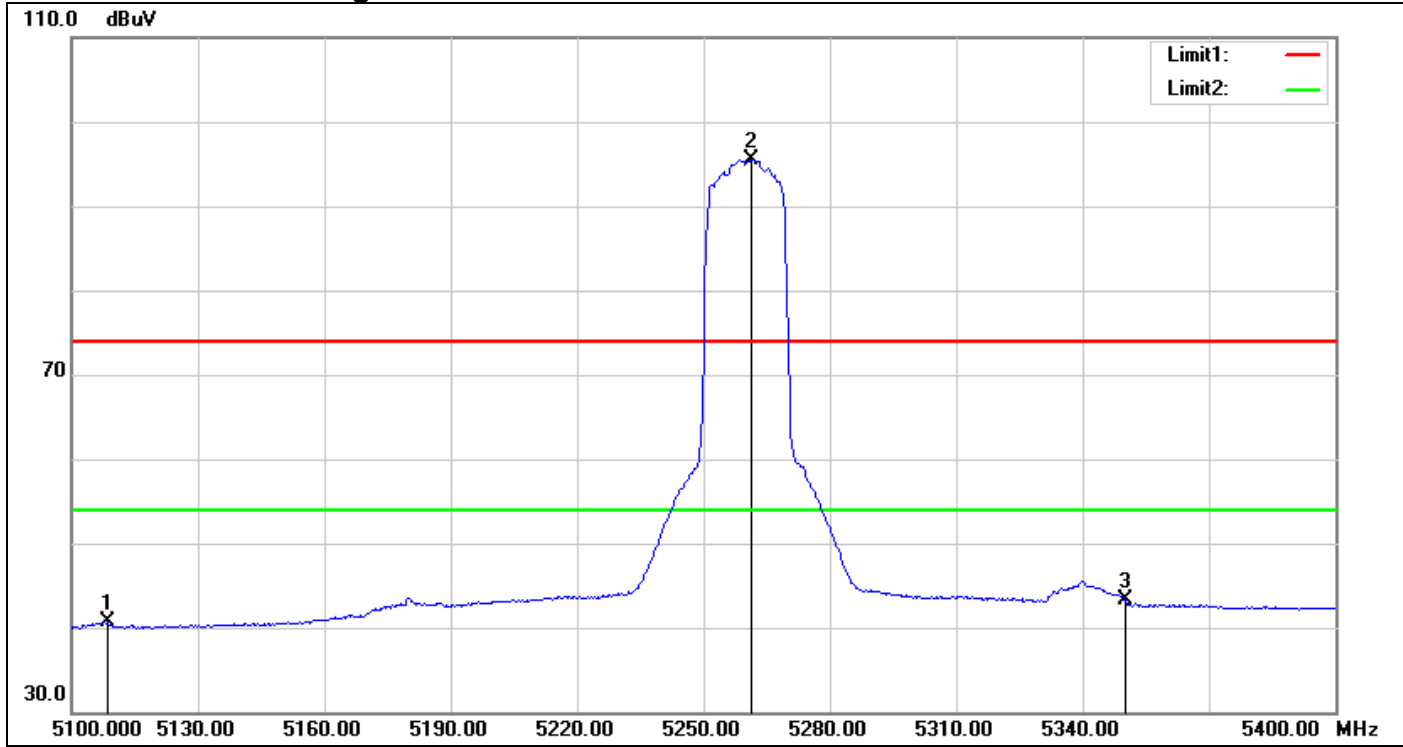

No.	Frequency (MHz)	Reading (dBuV)	Correct Factor(dB)	Result (dBuV)	Limit (dBuV)	Margin (dB)	Remark
1	5108.400	37.91	2.76	40.67	54.00	-13.33	AVG
2	5261.400	90.82	4.70	95.52	54.00	41.52	AVG
3	5350.200	37.90	5.31	43.21	54.00	-10.79	AVG

IEEE 802.11n HT20 MHz Mode / CH Mid

Detector mode: Peak

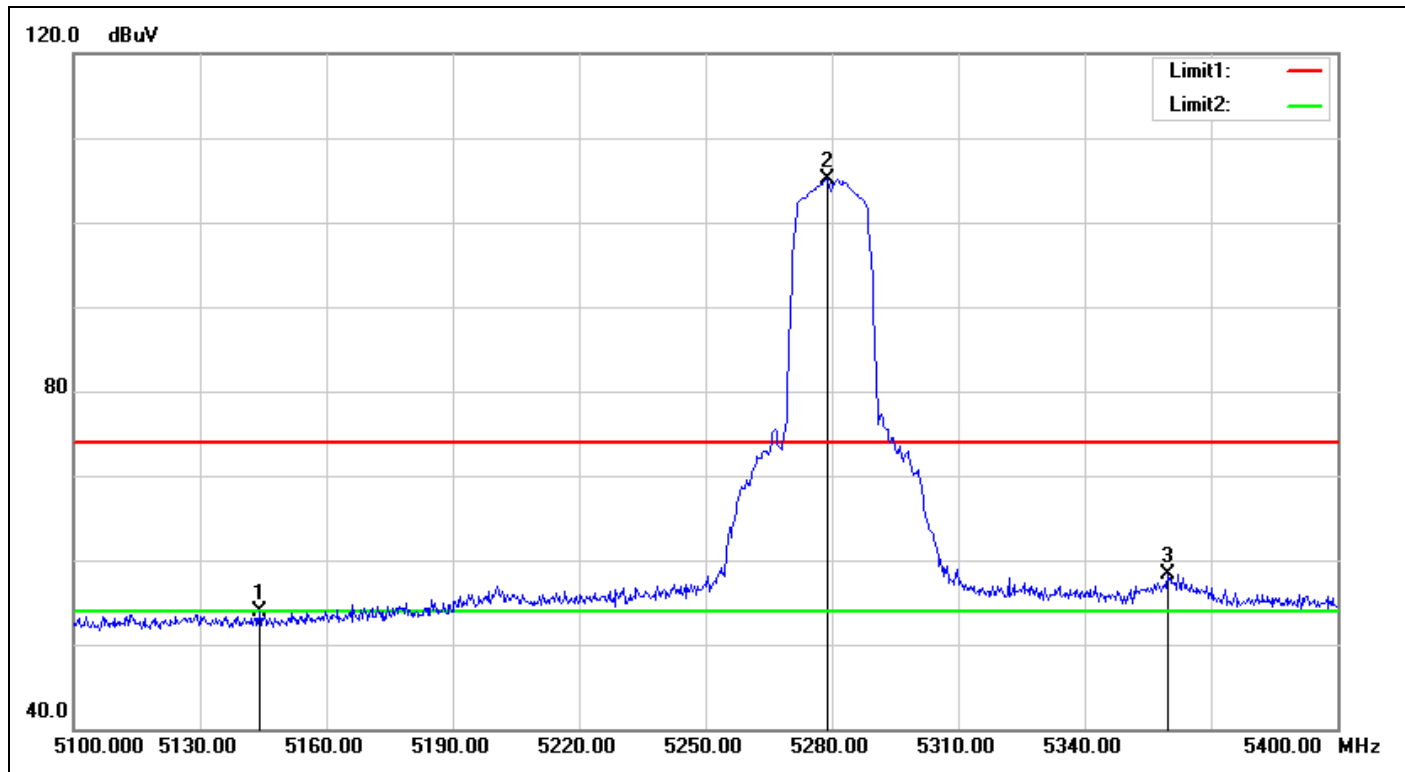

No.	Frequency (MHz)	Reading (dBuV)	Correct Factor(dB)	Result (dBuV)	Limit (dBuV)	Margin (dB)	Remark
1	5144.100	50.88	3.00	53.88	74.00	-20.12	peak
2	5278.800	100.40	4.76	105.16	74.00	31.16	peak
3	5359.800	52.99	5.39	58.38	74.00	-15.62	peak

Detector mode: Average

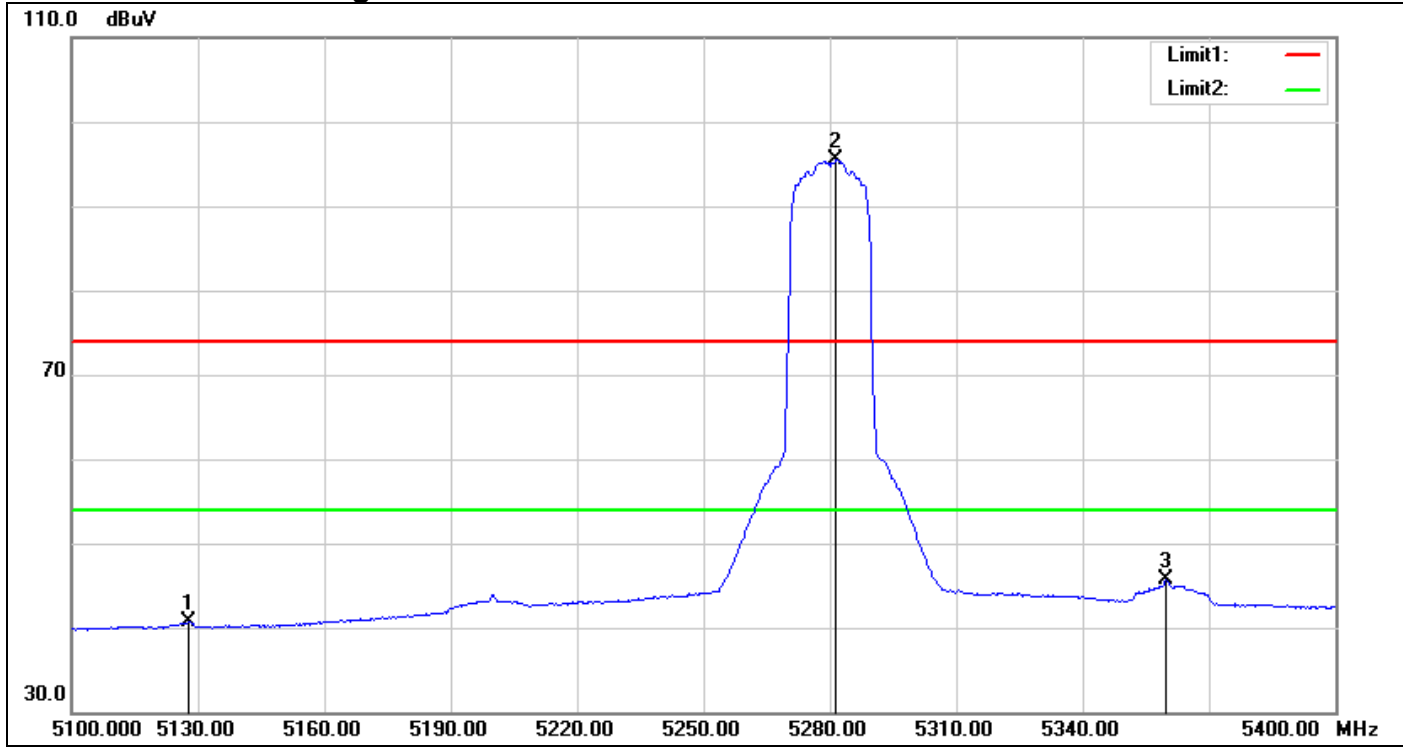

No.	Frequency (MHz)	Reading (dBuV)	Correct Factor(dB)	Result (dBuV)	Limit (dBuV)	Margin (dB)	Remark
1	5127.900	37.82	2.89	40.71	54.00	-13.29	AVG
2	5281.500	90.78	4.77	95.55	54.00	41.55	AVG
3	5359.800	40.23	5.39	45.62	54.00	-8.38	AVG

IEEE 802.11n HT20 MHz Mode / CH High

Detector mode: Peak

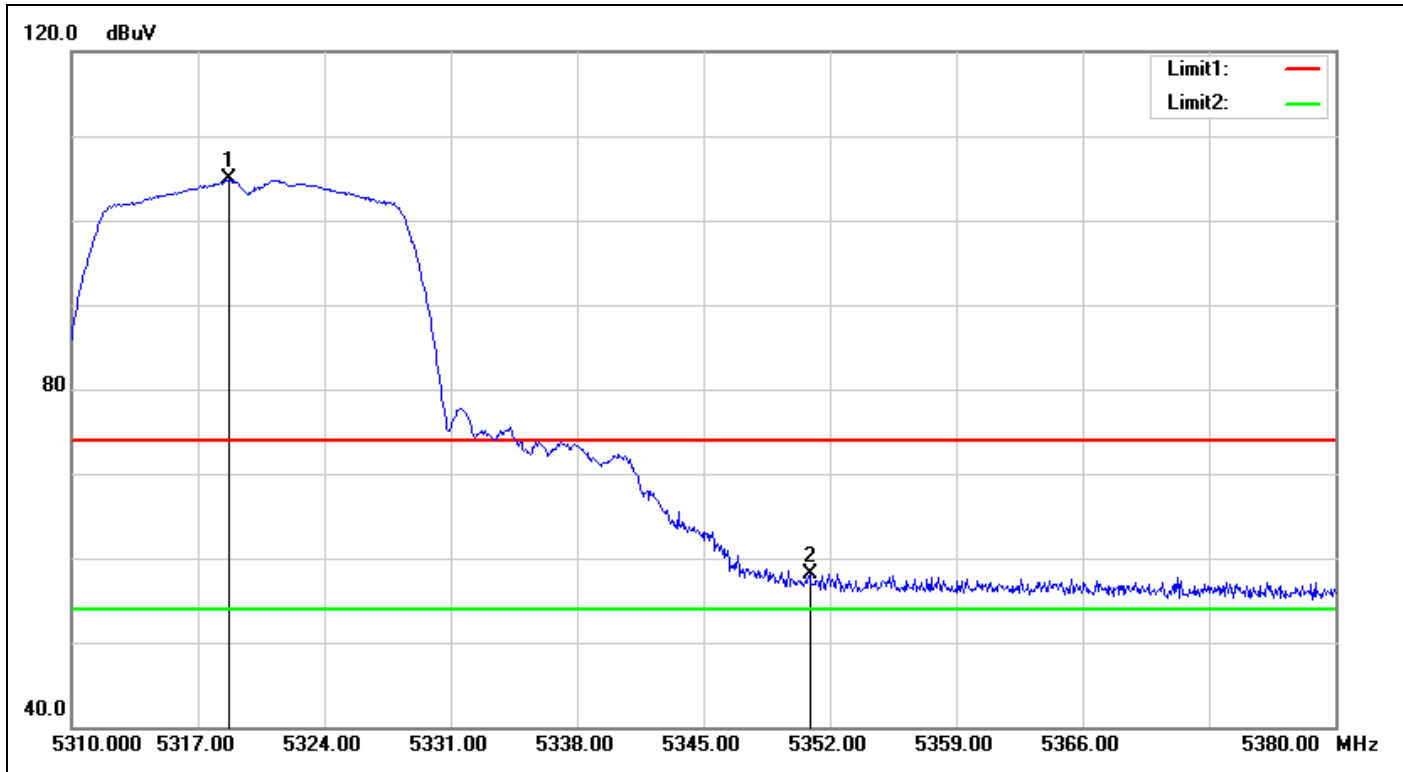

No.	Frequency (MHz)	Reading (dBuV)	Correct Factor(dB)	Result (dBuV)	Limit (dBuV)	Margin (dB)	Remark
1	5318.680	99.83	5.01	104.84	74.00	30.84	peak
2	5350.880	52.84	5.32	58.16	74.00	-15.84	peak

Detector mode: Average

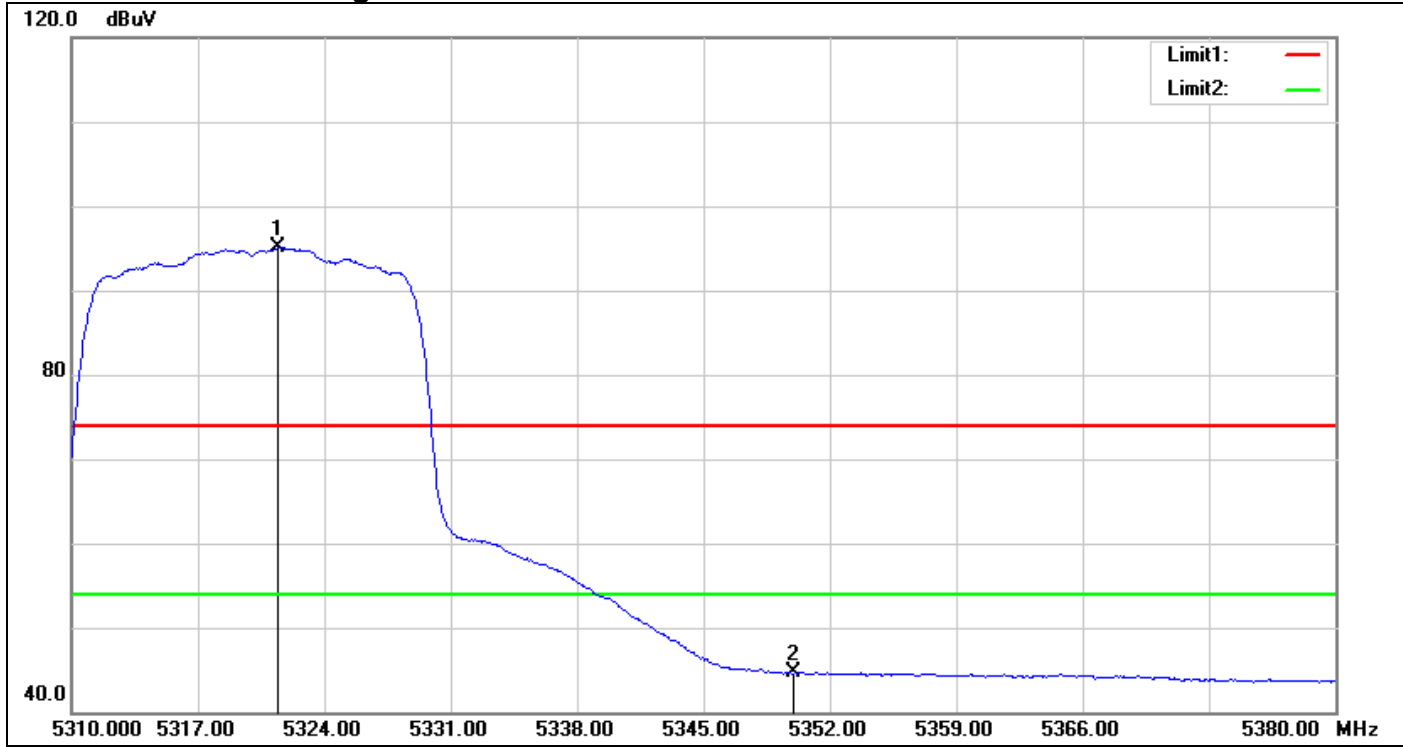

No.	Frequency (MHz)	Reading (dBuV)	Correct Factor(dB)	Result (dBuV)	Limit (dBuV)	Margin (dB)	Remark
1	5321.410	90.09	5.04	95.13	54.00	41.13	AVG
2	5350.000	39.32	5.31	44.63	54.00	-9.37	AVG

IEEE 802.11n HT40 MHz Mode / CH Low

Detector mode: Peak

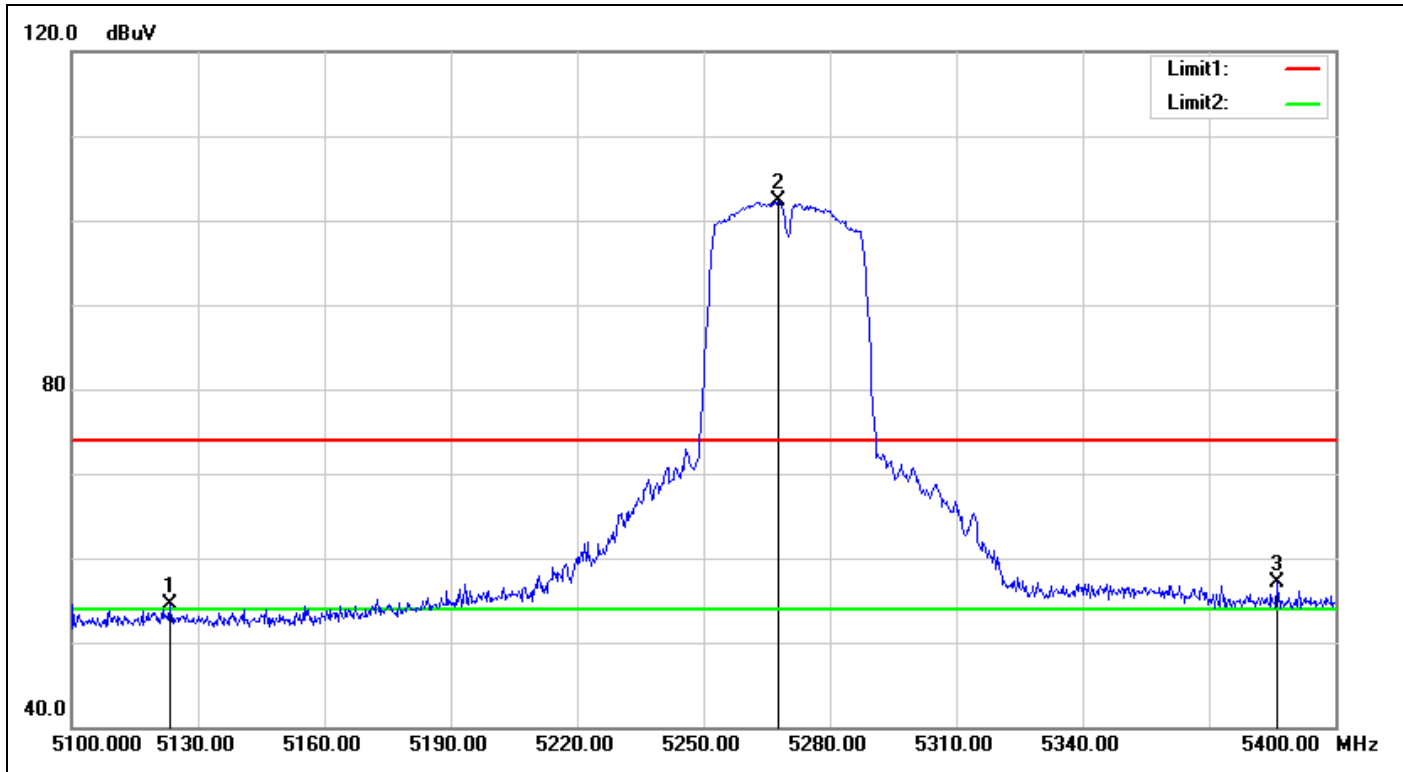

No.	Frequency (MHz)	Reading (dBuV)	Correct Factor(dB)	Result (dBuV)	Limit (dBuV)	Margin (dB)	Remark
1	5123.400	51.71	2.86	54.57	74.00	-19.43	peak
2	5267.700	97.51	4.72	102.23	74.00	28.23	peak
3	5386.200	51.54	5.61	57.15	74.00	-16.85	peak

Detector mode: Average

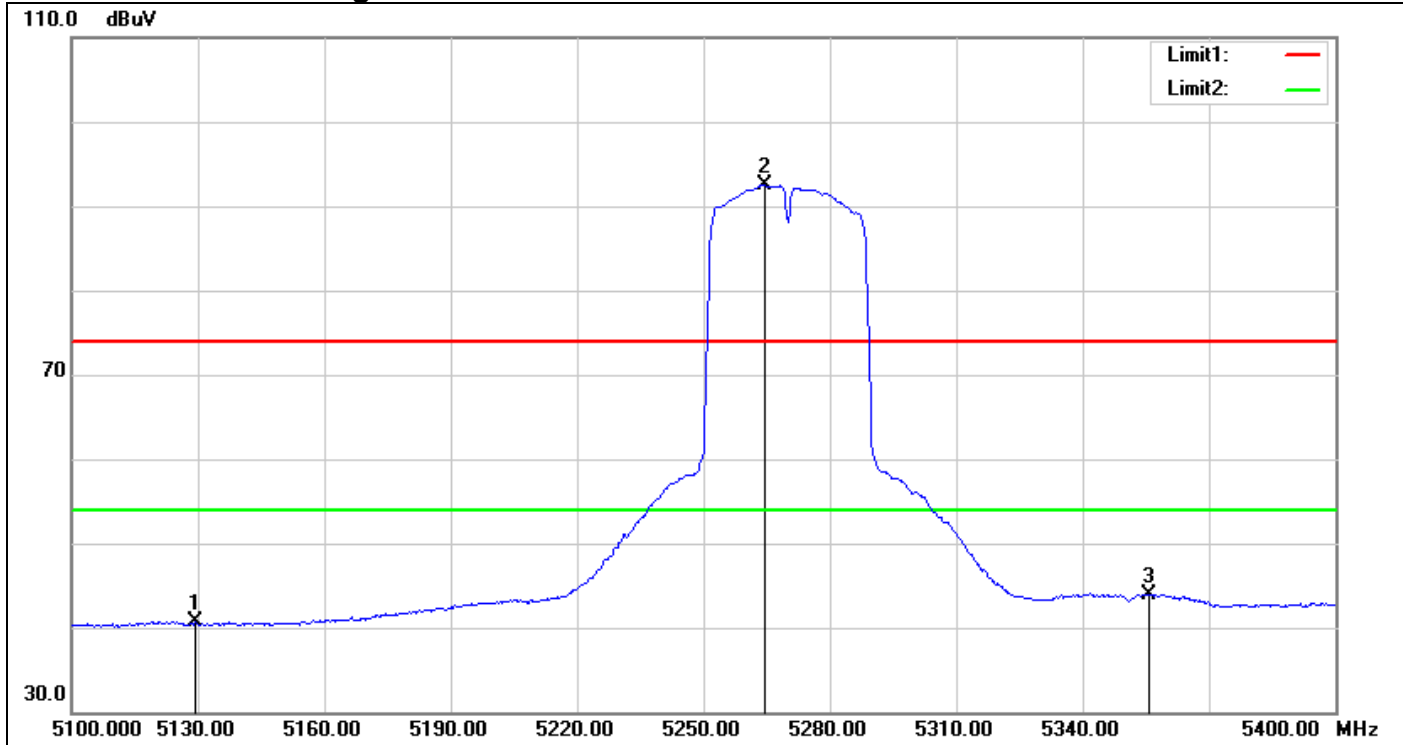

No.	Frequency (MHz)	Reading (dBuV)	Correct Factor(dB)	Result (dBuV)	Limit (dBuV)	Margin (dB)	Remark
1	5129.400	37.79	2.90	40.69	54.00	-13.31	AVG
2	5264.400	87.81	4.71	92.52	54.00	38.52	AVG
3	5355.900	38.62	5.36	43.98	54.00	-10.02	AVG

IEEE 802.11n HT40 MHz Mode / CH High

Detector mode: Peak

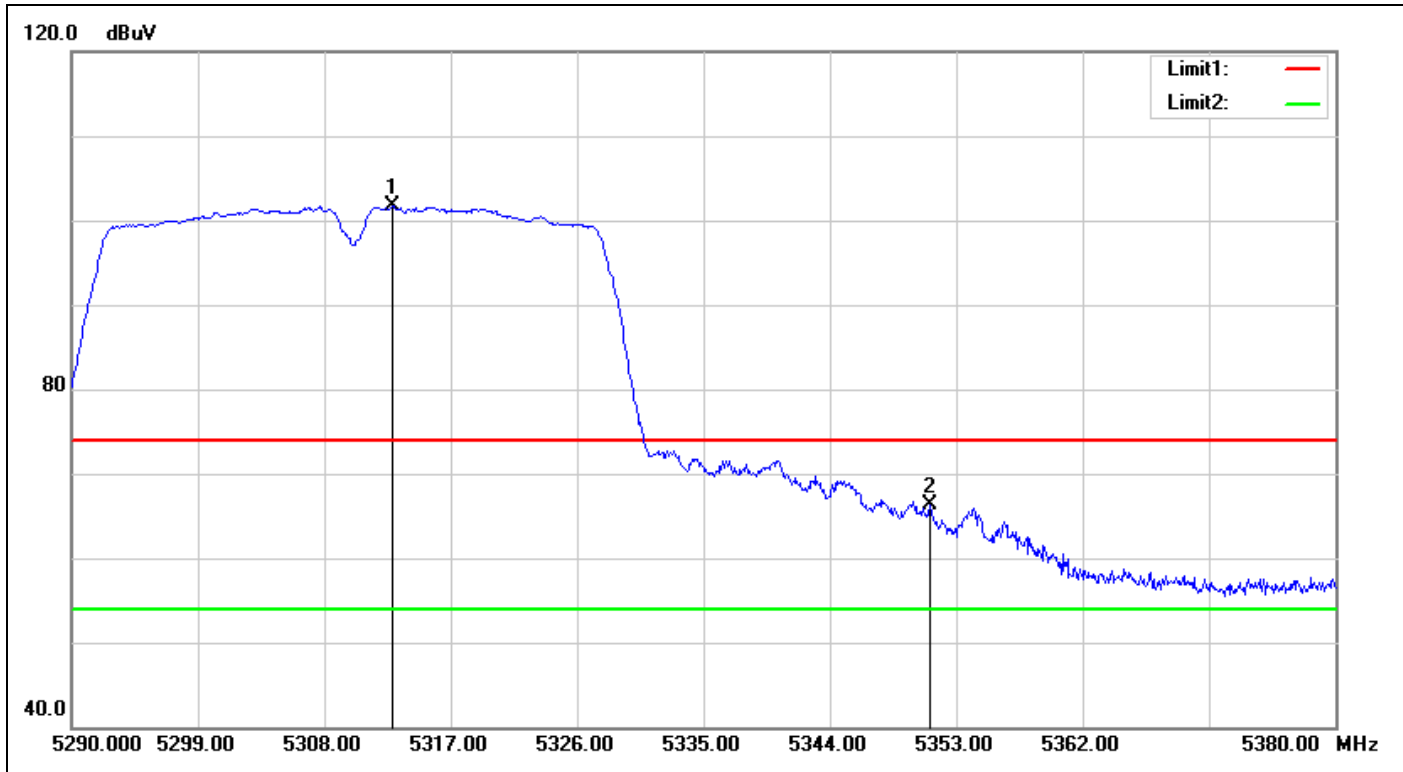

No.	Frequency (MHz)	Reading (dBuV)	Correct Factor(dB)	Result (dBuV)	Limit (dBuV)	Margin (dB)	Height (cm)	Degree (°)	Remark
1	5312.860	96.74	4.95	101.69	74.00	27.69	204	357	peak
2	5351.110	60.97	5.32	66.29	74.00	-7.71	204	90	peak

Detector mode: Average

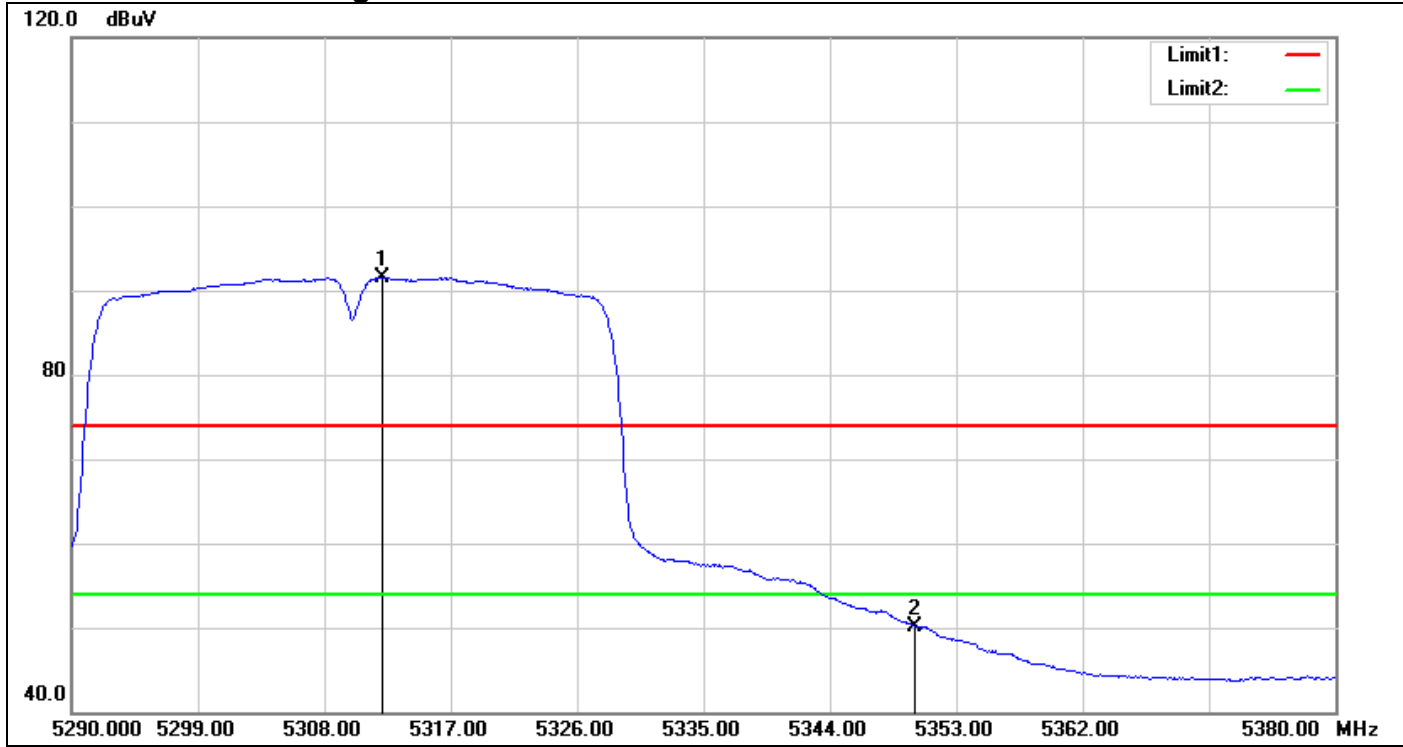

No.	Frequency (MHz)	Reading (dBuV)	Correct Factor(dB)	Result (dBuV)	Limit (dBuV)	Margin (dB)	Remark
1	5312.140	86.57	4.95	91.52	54.00	37.52	AVG
2	5350.000	44.74	5.31	50.05	54.00	-3.95	AVG

U-NII-2C

IEEE 802.11a Mode / CH Low

Detector mode: Peak

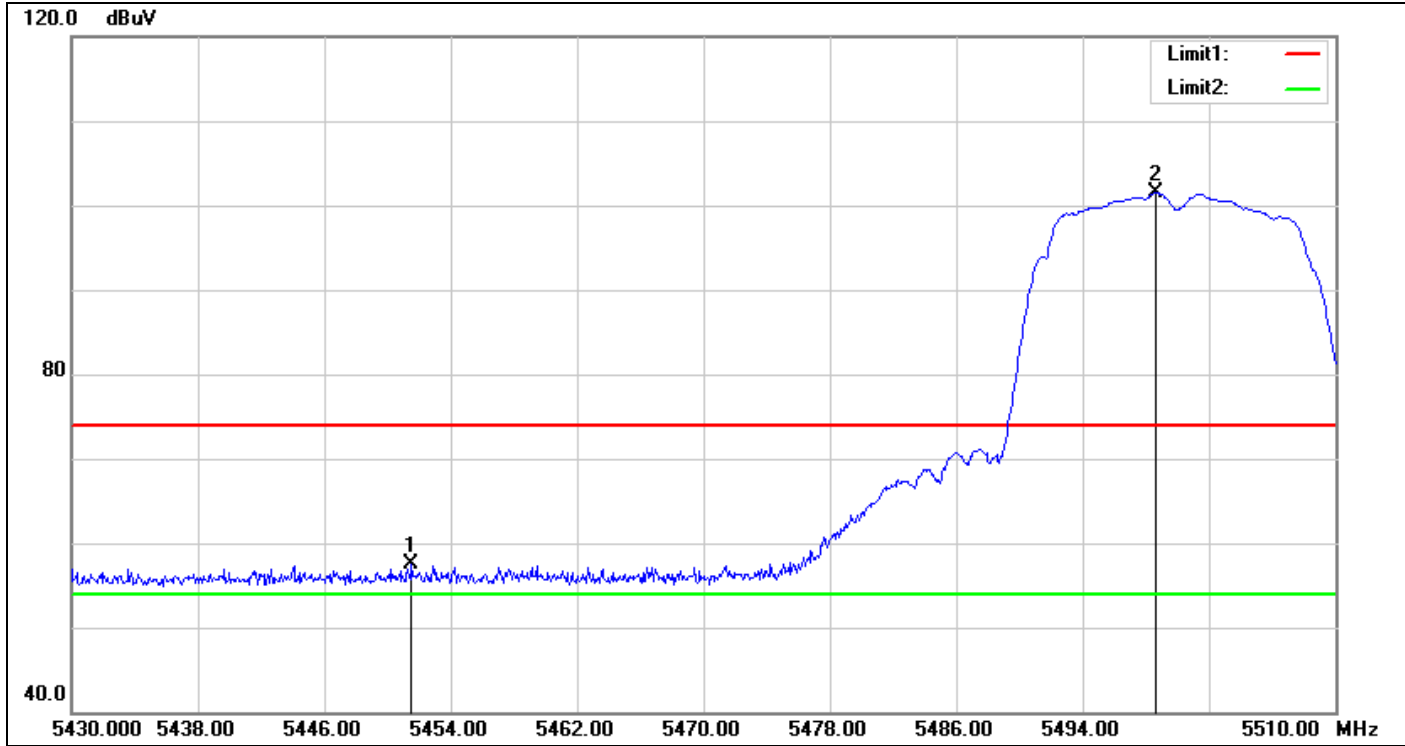

No.	Frequency (MHz)	Reading (dBuV)	Correct Factor(dB)	Result (dBuV)	Limit (dBuV)	Margin (dB)	Remark
1	5451.520	52.03	5.48	57.51	74.00	-16.49	peak
2	5498.640	96.20	5.26	101.46	74.00	27.46	peak

Detector mode: Average

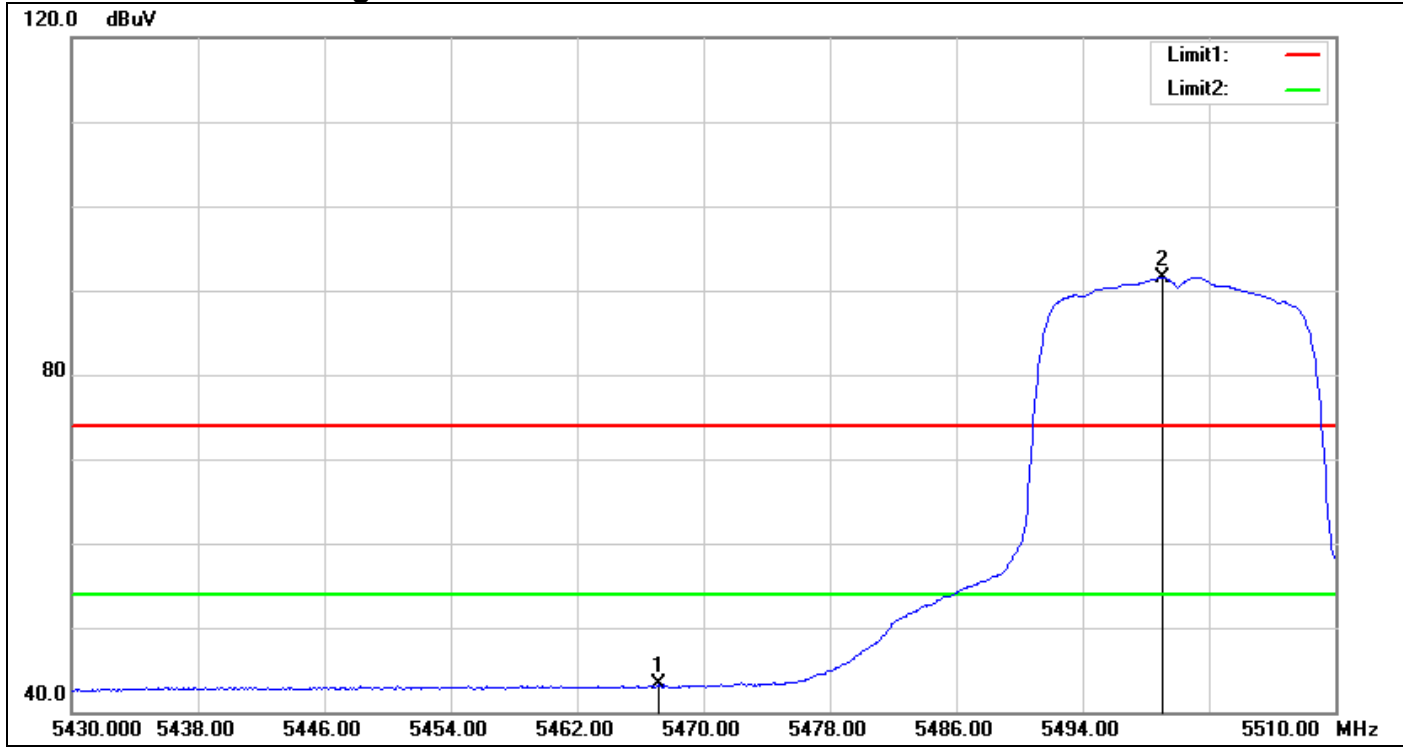

No.	Frequency (MHz)	Reading (dBuV)	Correct Factor(dB)	Result (dBuV)	Limit (dBuV)	Margin (dB)	Remark
1	5467.200	37.87	5.40	43.27	54.00	-10.73	AVG
2	5499.040	86.31	5.25	91.56	54.00	37.56	AVG

IEEE 802.11a Mode / CH Mid

Detector mode: Peak

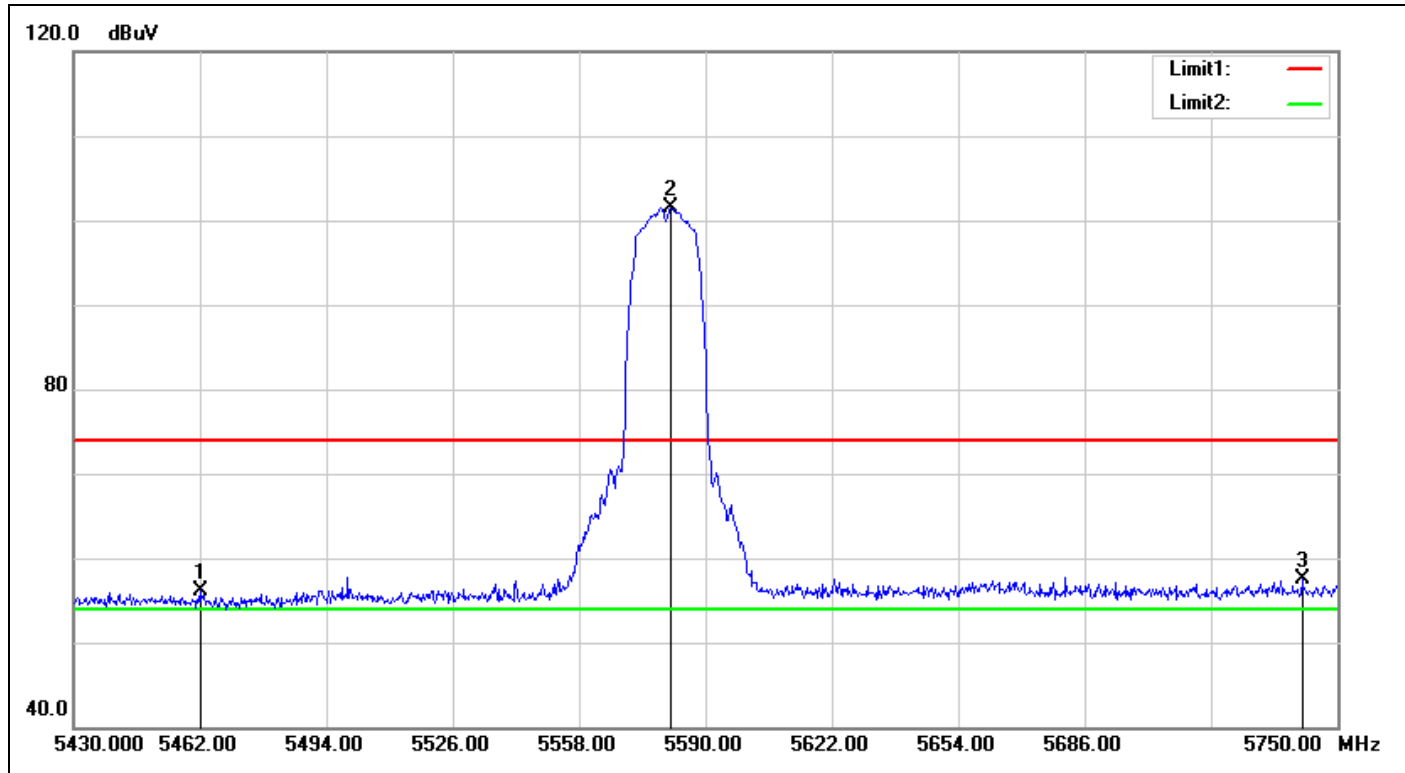

No.	Frequency (MHz)	Reading (dBuV)	Correct Factor(dB)	Result (dBuV)	Limit (dBuV)	Margin (dB)	Remark
1	5462.000	50.65	5.43	56.08	74.00	-17.92	peak
2	5581.040	95.97	5.60	101.57	74.00	27.57	peak
3	5741.040	51.16	6.28	57.44	74.00	-16.56	peak

Detector mode: Average

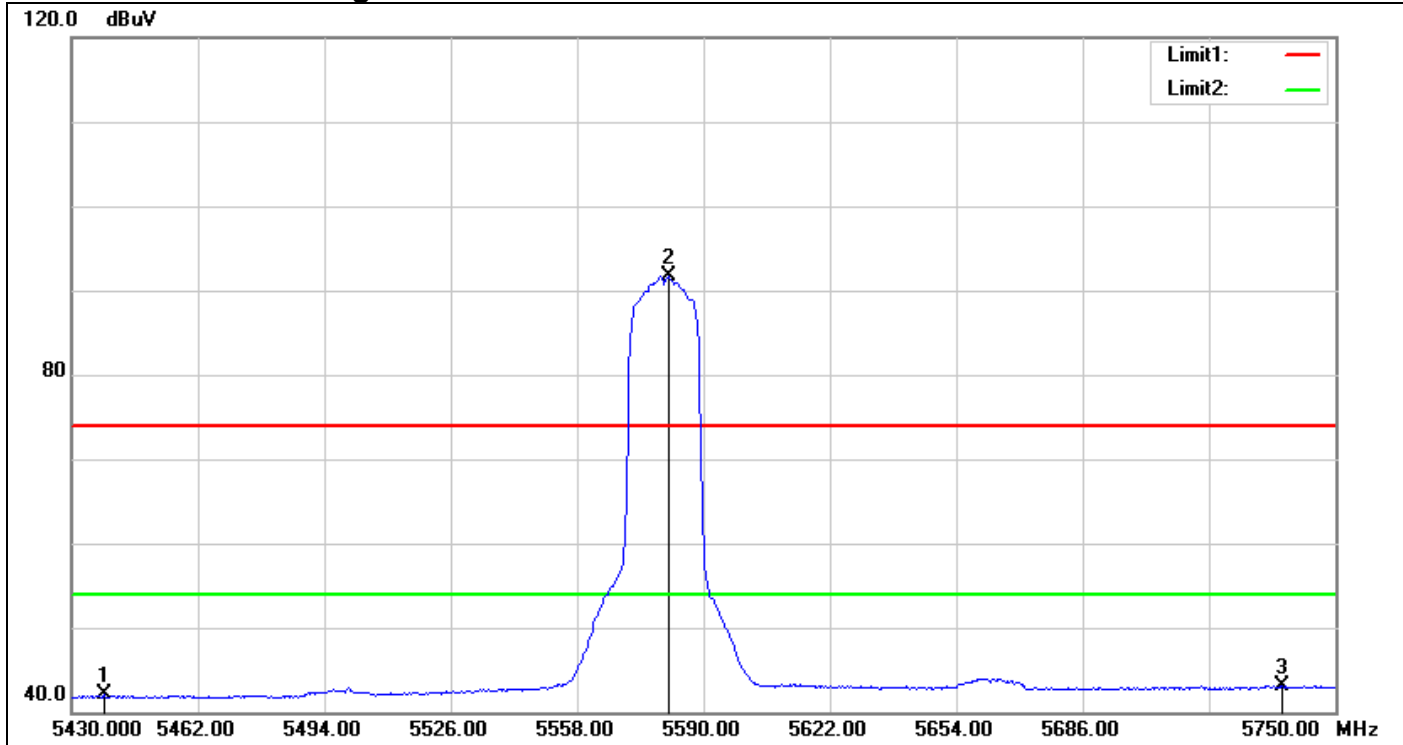

No.	Frequency (MHz)	Reading (dBuV)	Correct Factor(dB)	Result (dBuV)	Limit (dBuV)	Margin (dB)	Remark
1	5438.320	36.54	5.54	42.08	54.00	-11.92	AVG
2	5581.040	86.04	5.60	91.64	54.00	37.64	AVG
3	5736.560	36.84	6.26	43.10	54.00	-10.90	AVG

IEEE 802.11a Mode / CH High

Detector mode: Peak

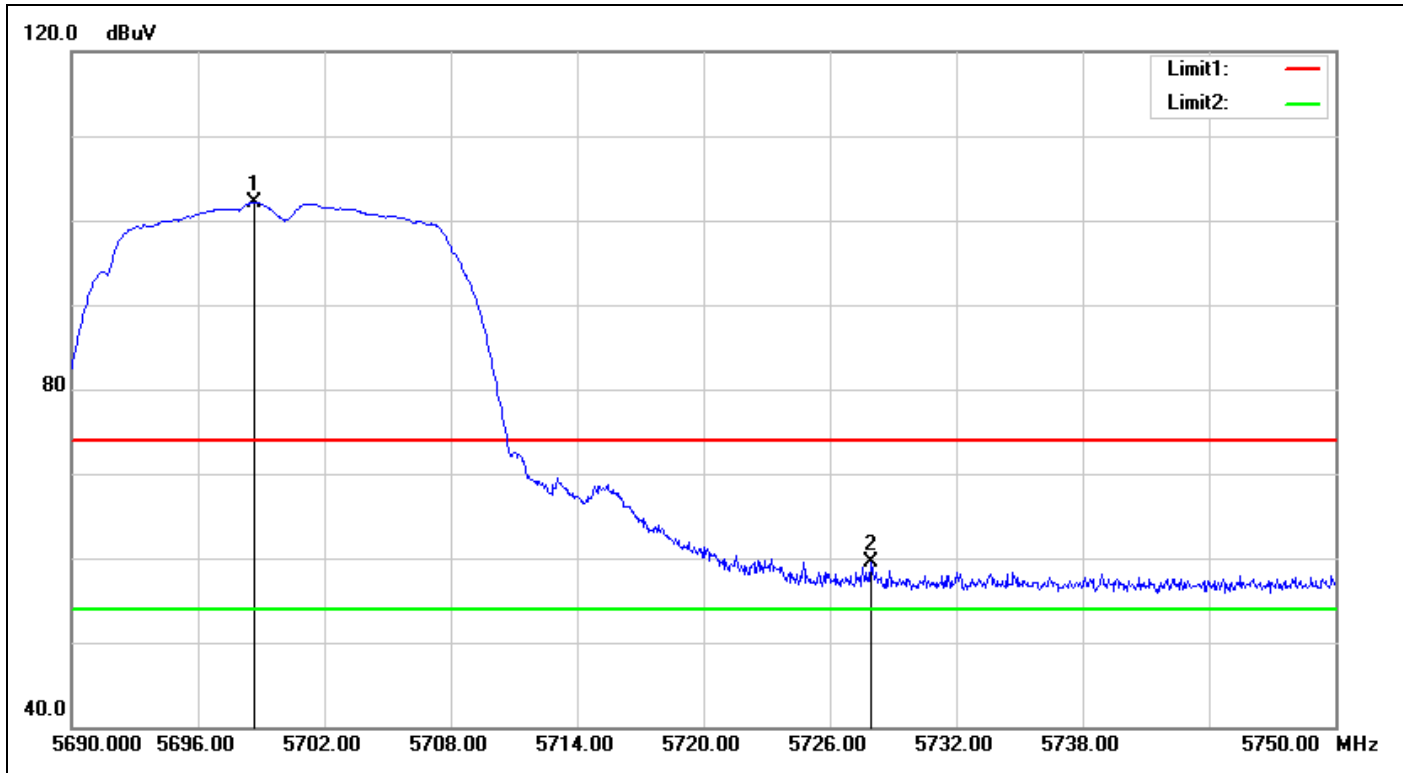

No.	Frequency (MHz)	Reading (dBuV)	Correct Factor(dB)	Result (dBuV)	Limit (dBuV)	Margin (dB)	Remark
1	5698.700	96.04	6.10	102.14	74.00	28.14	peak
2	5727.980	53.25	6.22	59.47	74.00	-14.53	peak

Detector mode: Average

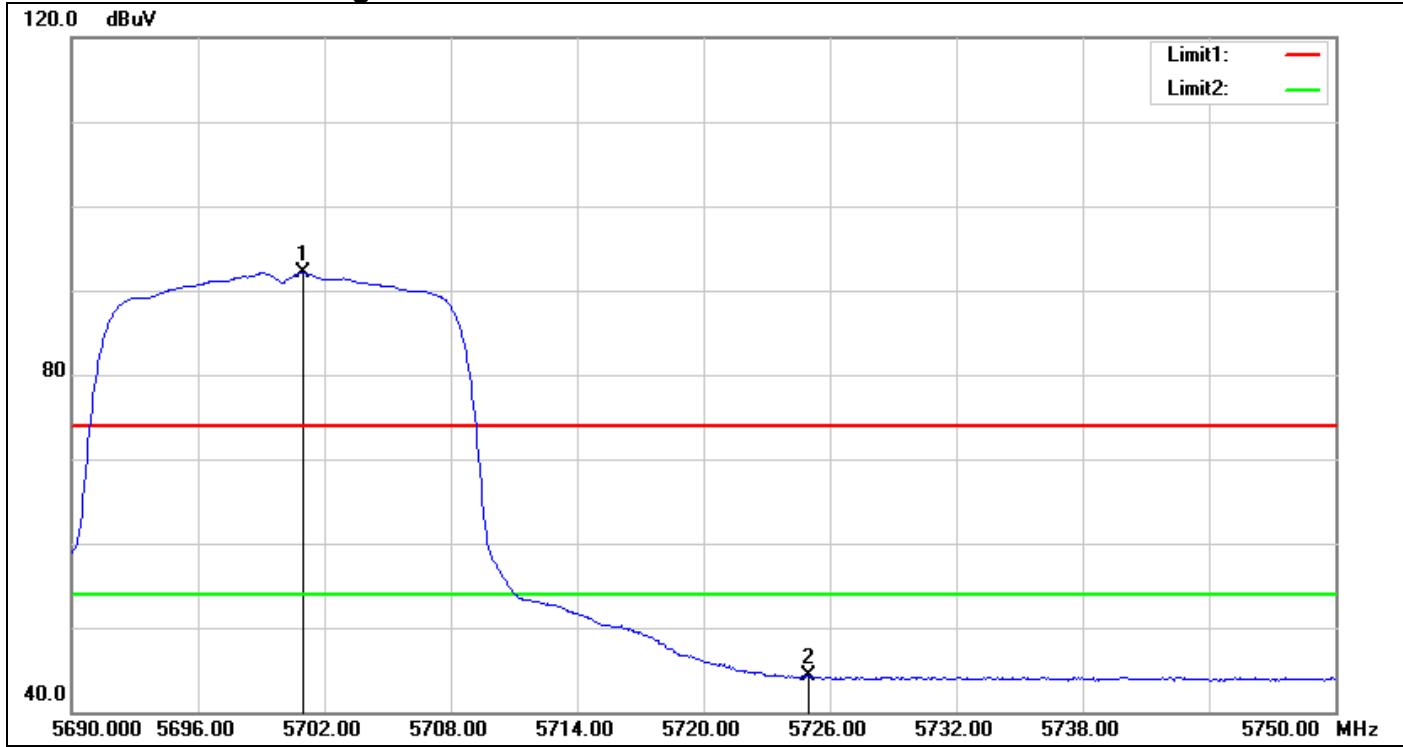

No.	Frequency (MHz)	Reading (dBuV)	Correct Factor(dB)	Result (dBuV)	Limit (dBuV)	Margin (dB)	Remark
1	5700.980	85.97	6.11	92.08	54.00	38.08	AVG
2	5725.000	38.03	6.21	44.24	54.00	-9.76	AVG

IEEE 802.11n HT20 MHz Mode / CH Low

Detector mode: Peak

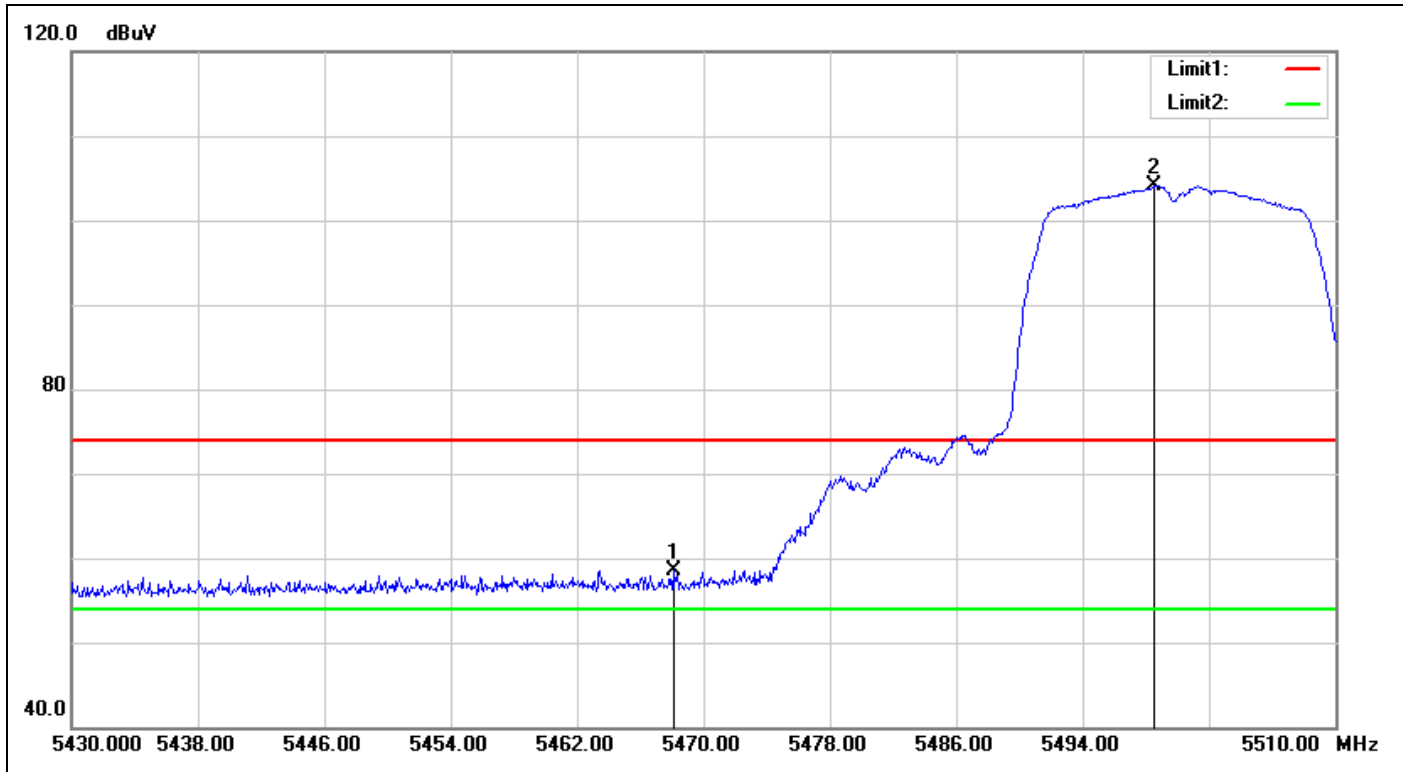

No.	Frequency (MHz)	Reading (dBuV)	Correct Factor(dB)	Result (dBuV)	Limit (dBuV)	Margin (dB)	Remark
1	5468.080	53.02	5.40	58.42	74.00	-15.58	peak
2	5498.560	98.83	5.26	104.09	74.00	30.09	peak

Detector mode: Average

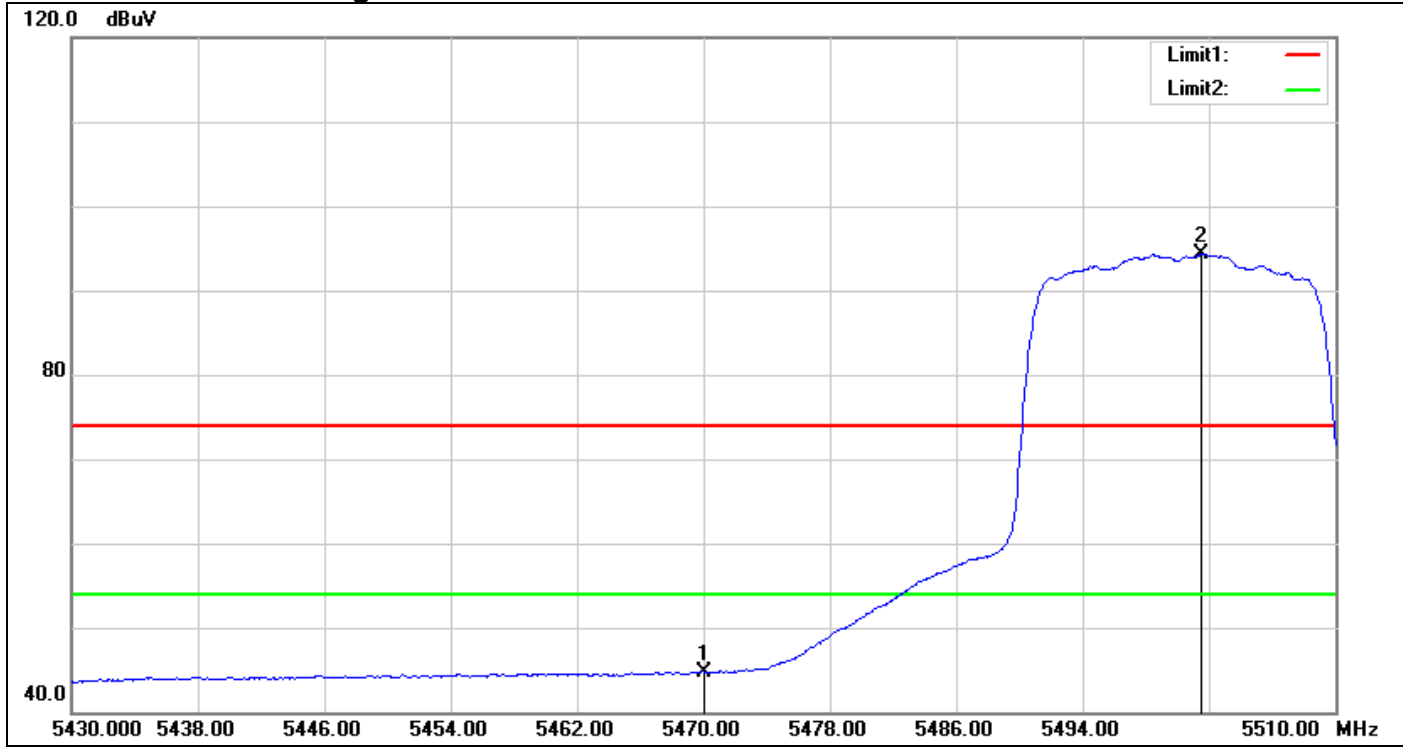

No.	Frequency (MHz)	Reading (dBuV)	Correct Factor(dB)	Result (dBuV)	Limit (dBuV)	Margin (dB)	Remark
1	5470.000	39.34	5.39	44.73	54.00	-9.27	AVG
2	5501.520	89.10	5.26	94.36	54.00	40.36	AVG

IEEE 802.11n HT20 MHz Mode / CH Mid

Detector mode: Peak

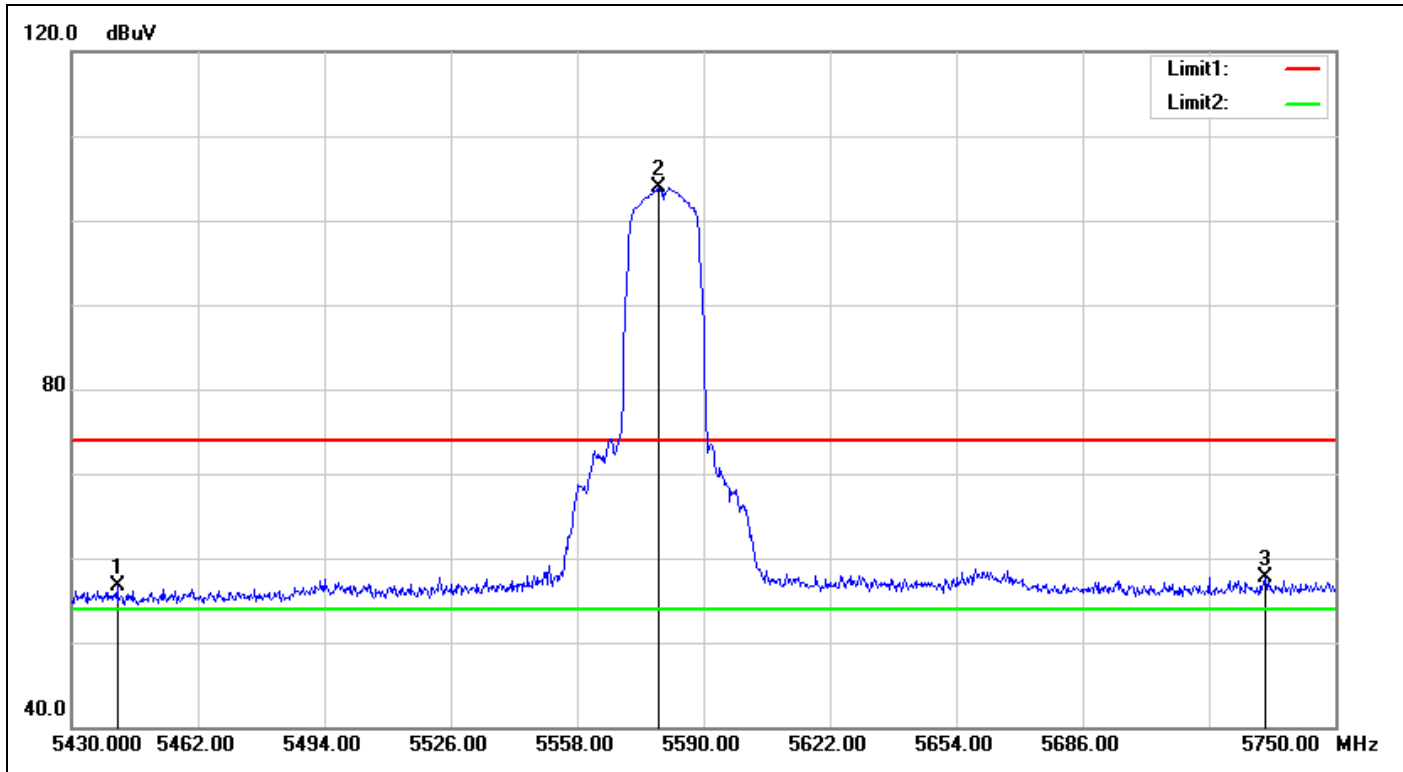

No.	Frequency (MHz)	Reading (dBuV)	Correct Factor(dB)	Result (dBuV)	Limit (dBuV)	Margin (dB)	Remark
1	5441.520	51.10	5.52	56.62	74.00	-17.38	peak
2	5578.800	98.36	5.59	103.95	74.00	29.95	peak
3	5732.400	51.50	6.24	57.74	74.00	-16.26	peak

Detector mode: Average

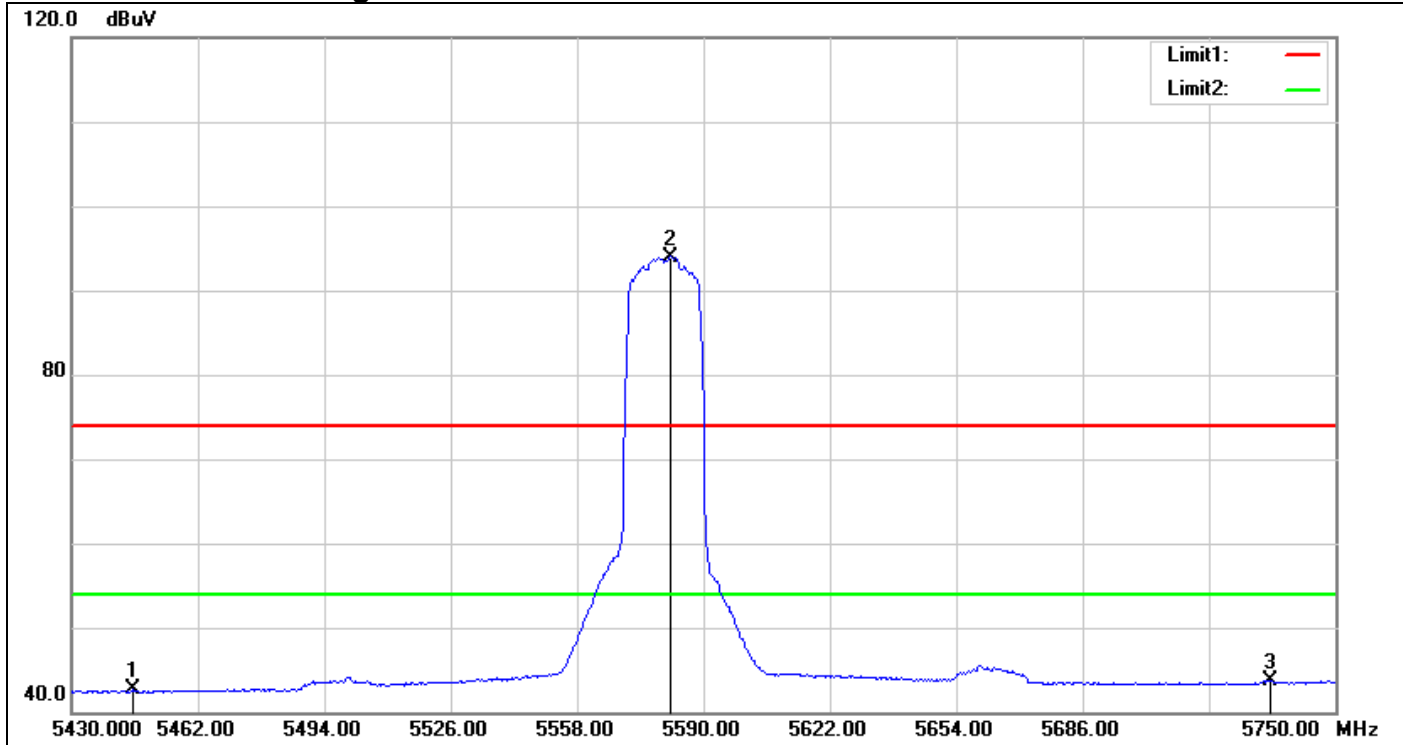

No.	Frequency (MHz)	Reading (dBuV)	Correct Factor(dB)	Result (dBuV)	Limit (dBuV)	Margin (dB)	Remark
1	5445.360	37.15	5.51	42.66	54.00	-11.34	AVG
2	5581.680	88.40	5.60	94.00	54.00	40.00	AVG
3	5733.680	37.48	6.25	43.73	54.00	-10.27	AVG

IEEE 802.11n HT20 MHz Mode / CH High

Detector mode: Peak

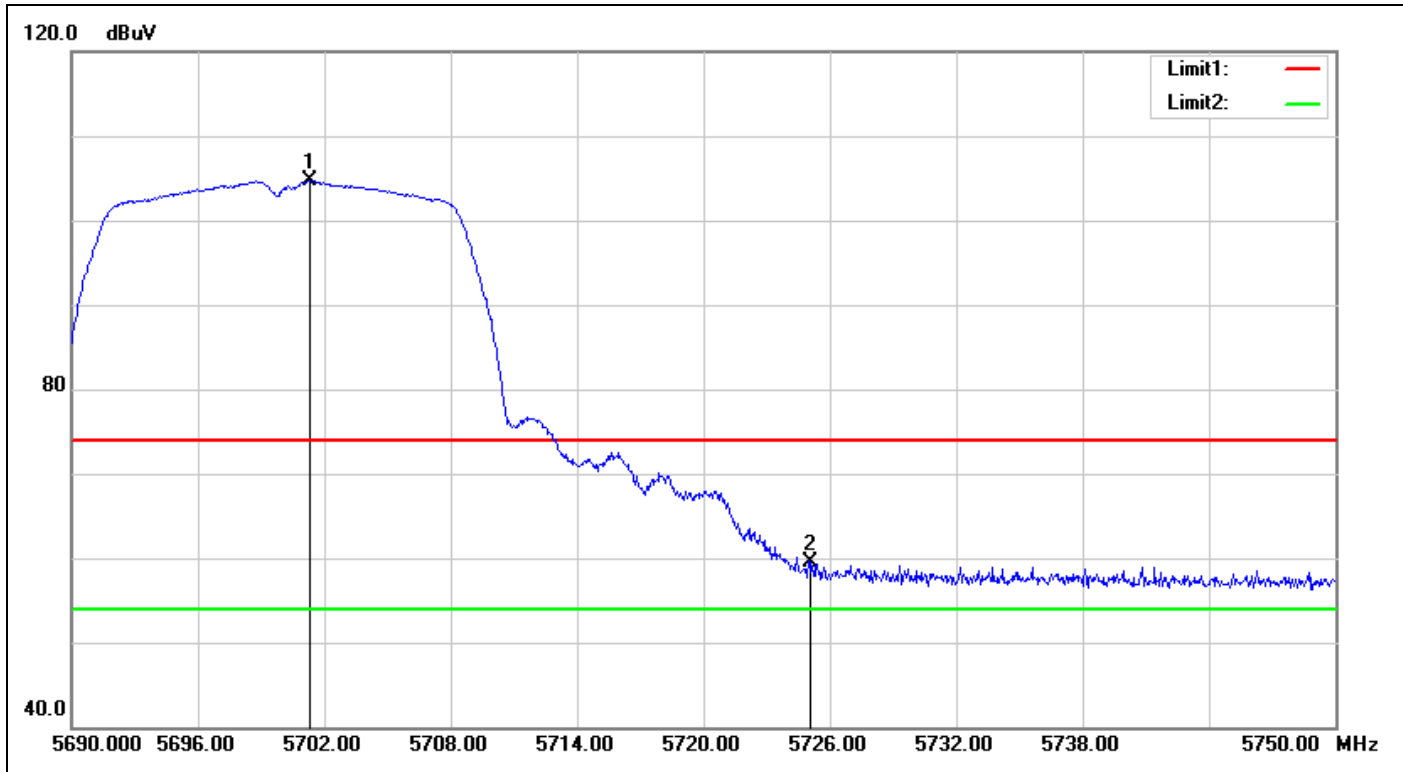

No.	Frequency (MHz)	Reading (dBuV)	Correct Factor(dB)	Result (dBuV)	Limit (dBuV)	Margin (dB)	Remark
1	5701.340	98.64	6.11	104.75	74.00	30.75	peak
2	5725.100	53.30	6.21	59.51	74.00	-14.49	peak

Detector mode: Average

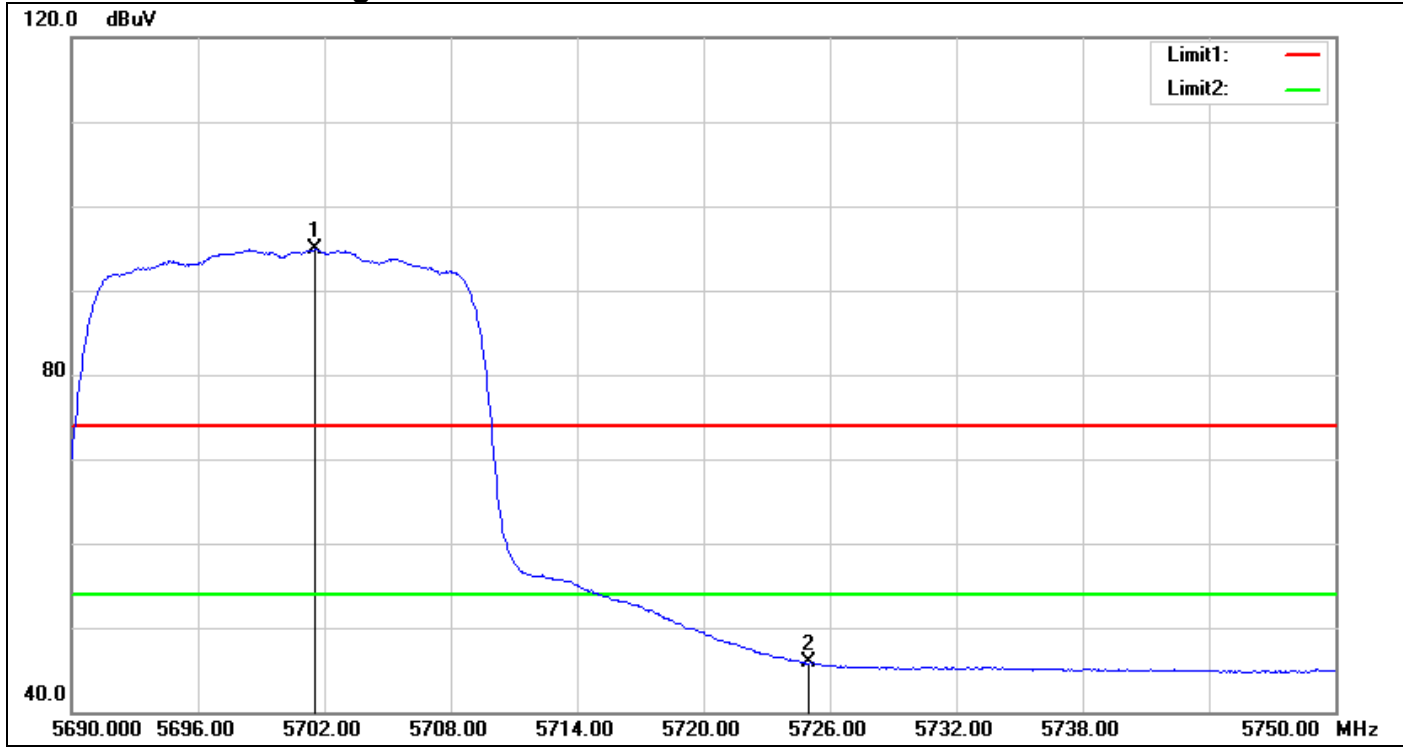

No.	Frequency (MHz)	Reading (dBuV)	Correct Factor(dB)	Result (dBuV)	Limit (dBuV)	Margin (dB)	Remark
1	5701.520	88.71	6.11	94.82	54.00	40.82	AVG
2	5725.000	39.62	6.21	45.83	54.00	-8.17	AVG

IEEE 802.11n HT40 MHz Mode / CH Low

Detector mode: Peak

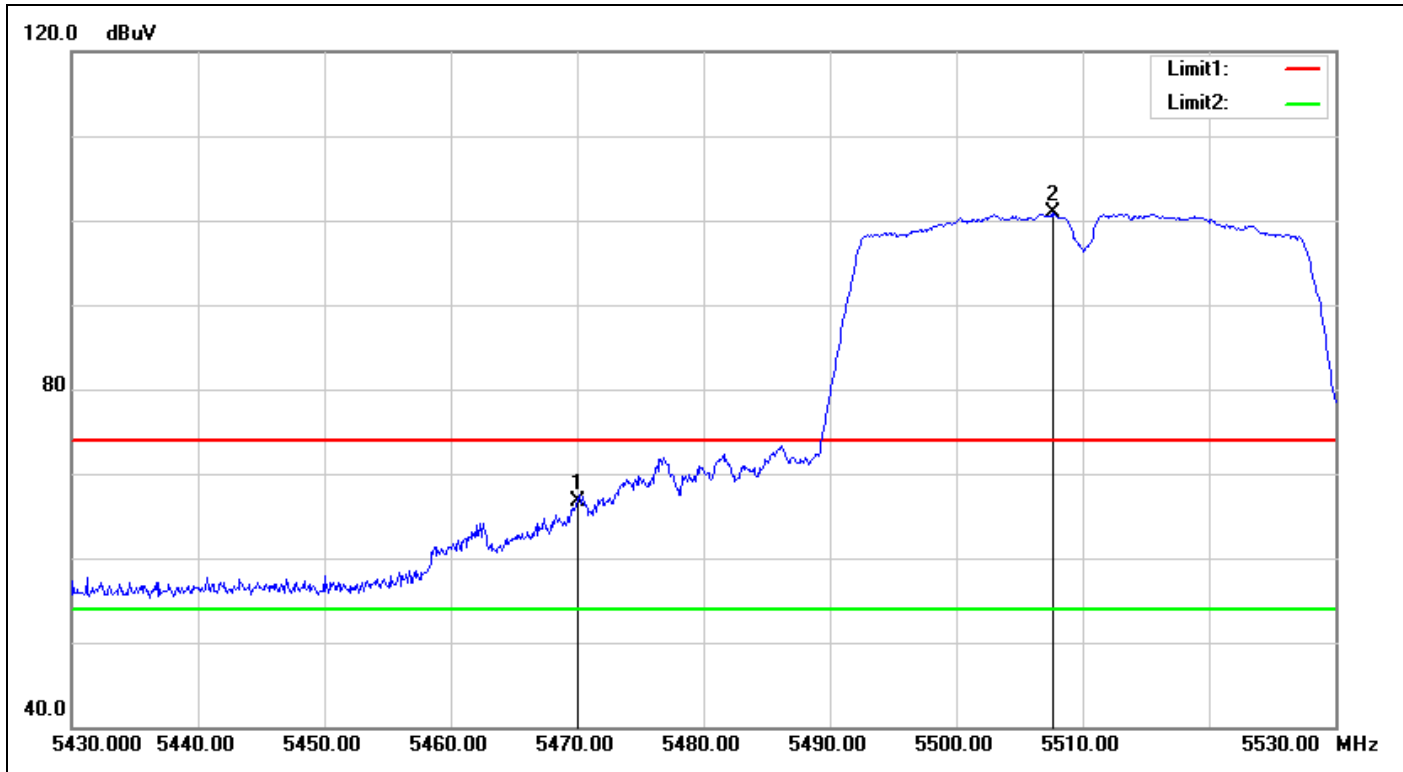

No.	Frequency (MHz)	Reading (dBuV)	Correct Factor(dB)	Result (dBuV)	Limit (dBuV)	Margin (dB)	Remark
1	5470.000	61.31	5.39	66.70	74.00	-7.30	peak
2	5507.600	95.56	5.28	100.84	74.00	26.84	peak

Detector mode: Average

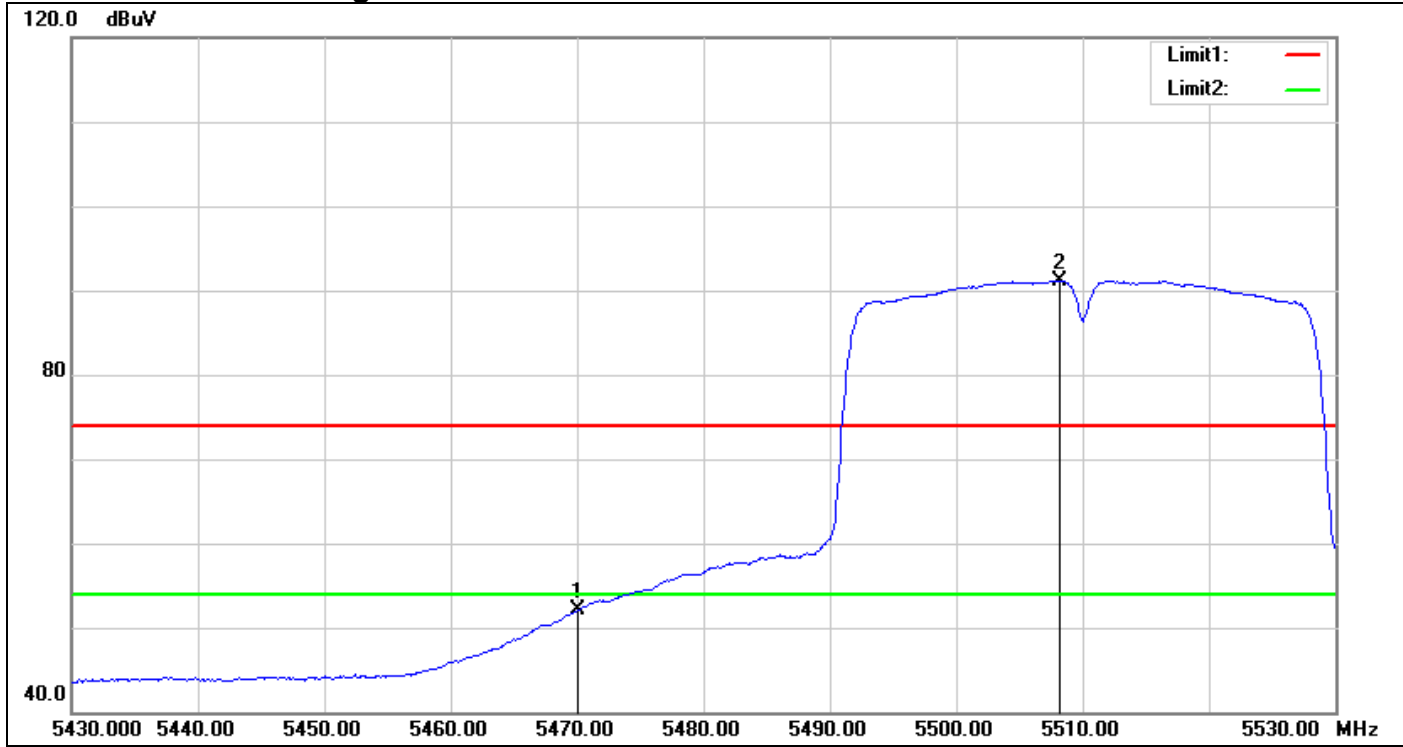

No.	Frequency (MHz)	Reading (dBuV)	Correct Factor(dB)	Result (dBuV)	Limit (dBuV)	Margin (dB)	Remark
1	5470.000	46.70	5.39	52.09	54.00	-1.91	AVG
2	5508.200	85.90	5.28	91.18	54.00	37.18	AVG

IEEE 802.11n HT40 MHz Mode / CH Mid

Detector mode: Peak

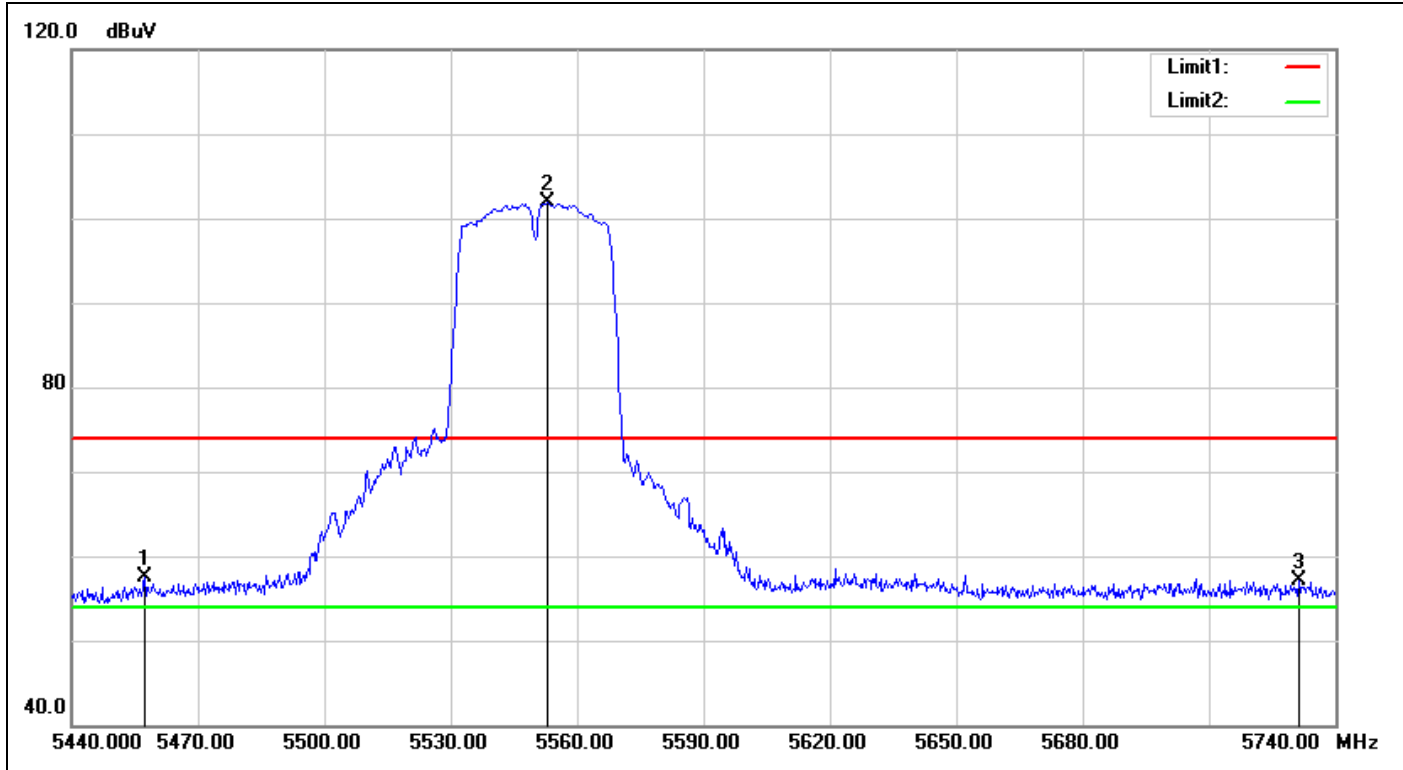

No.	Frequency (MHz)	Reading (dBuV)	Correct Factor(dB)	Result (dBuV)	Limit (dBuV)	Margin (dB)	Remark
1	5457.400	52.07	5.45	57.52	74.00	-16.48	peak
2	5552.800	96.46	5.47	101.93	74.00	27.93	peak
3	5731.300	50.77	6.24	57.01	74.00	-16.99	peak

Detector mode: Average

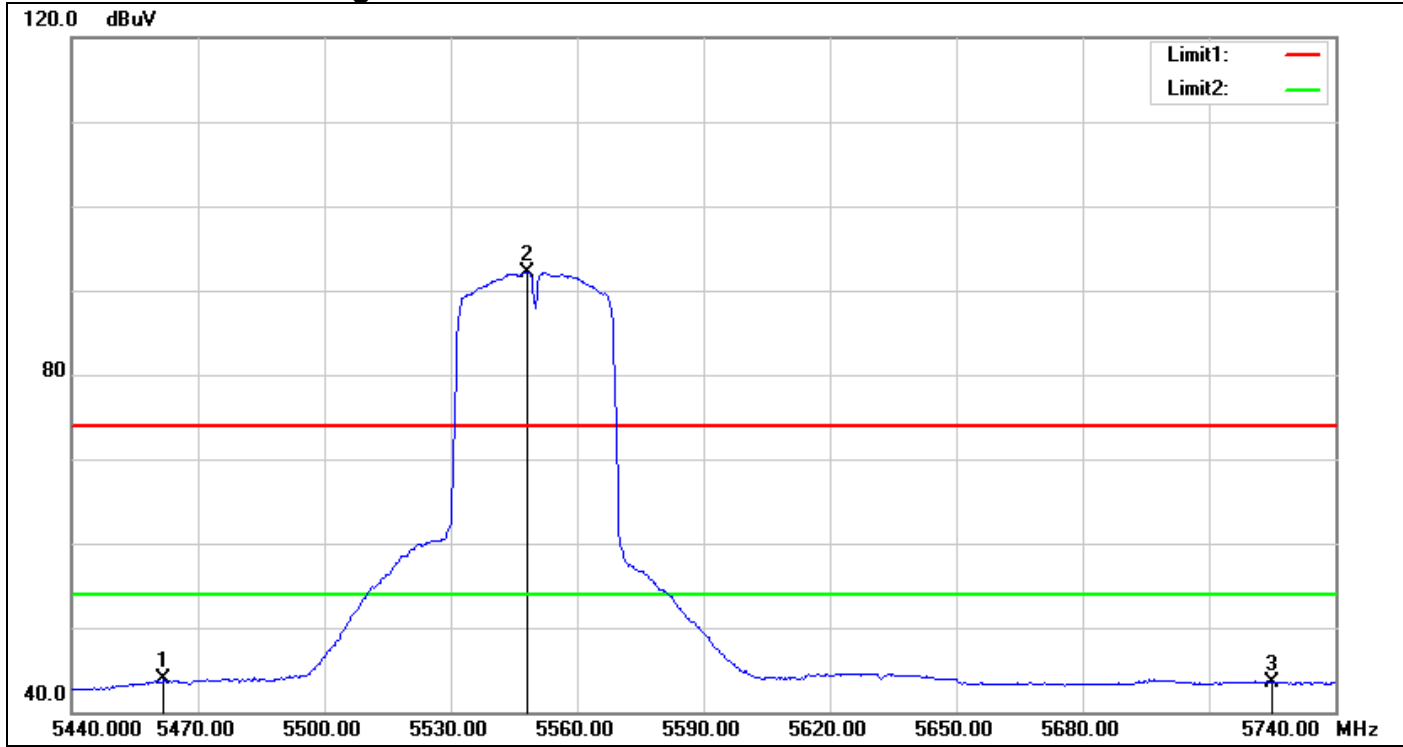

No.	Frequency (MHz)	Reading (dBuV)	Correct Factor(dB)	Result (dBuV)	Limit (dBuV)	Margin (dB)	Remark
1	5461.900	38.39	5.43	43.82	54.00	-10.18	AVG
2	5548.300	86.65	5.46	92.11	54.00	38.11	AVG
3	5725.000	37.22	6.21	43.43	54.00	-10.57	AVG

IEEE 802.11n HT40 MHz Mode / CH High

Detector mode: Peak

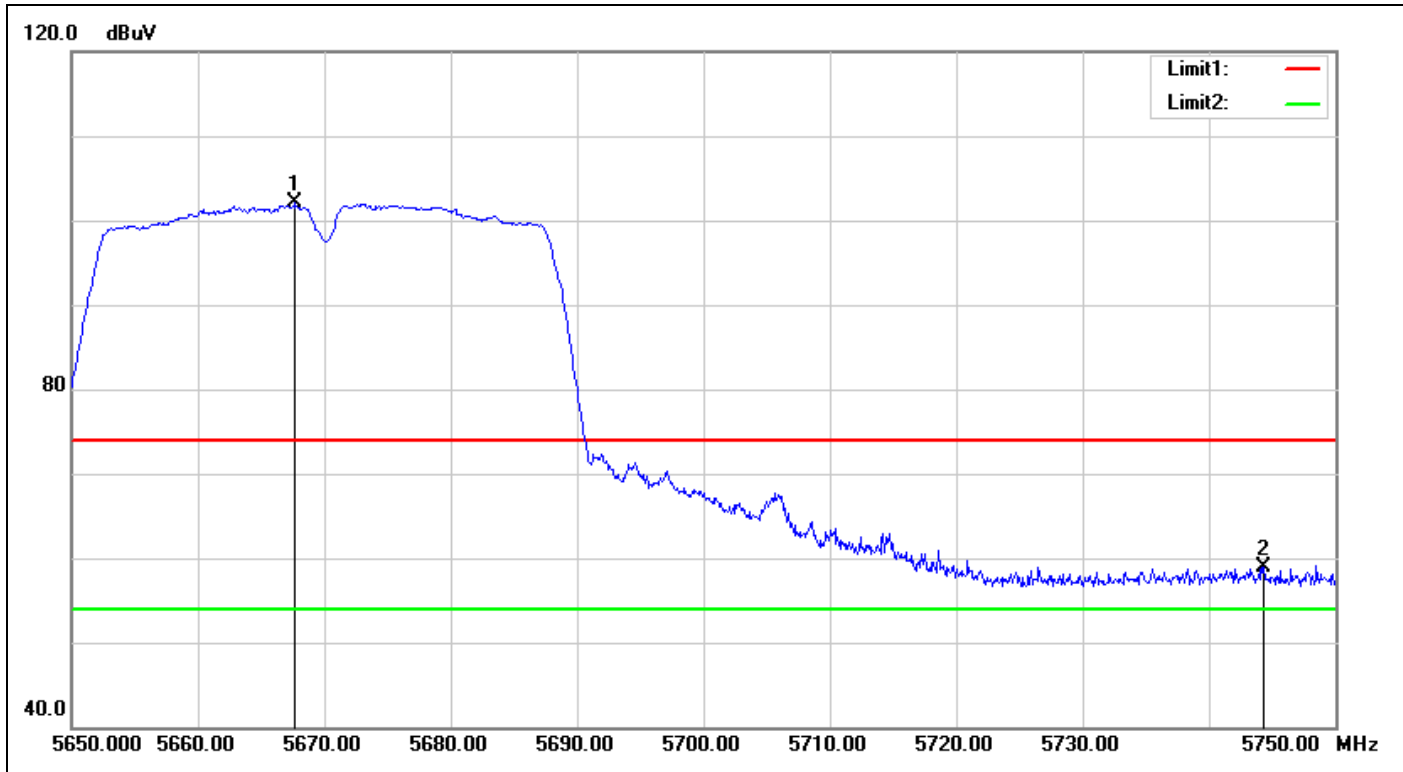

No.	Frequency (MHz)	Reading (dBuV)	Correct Factor(dB)	Result (dBuV)	Limit (dBuV)	Margin (dB)	Remark
1	5667.700	96.09	5.96	102.05	74.00	28.05	peak
2	5744.300	52.66	6.29	58.95	74.00	-15.05	peak

Detector mode: Average

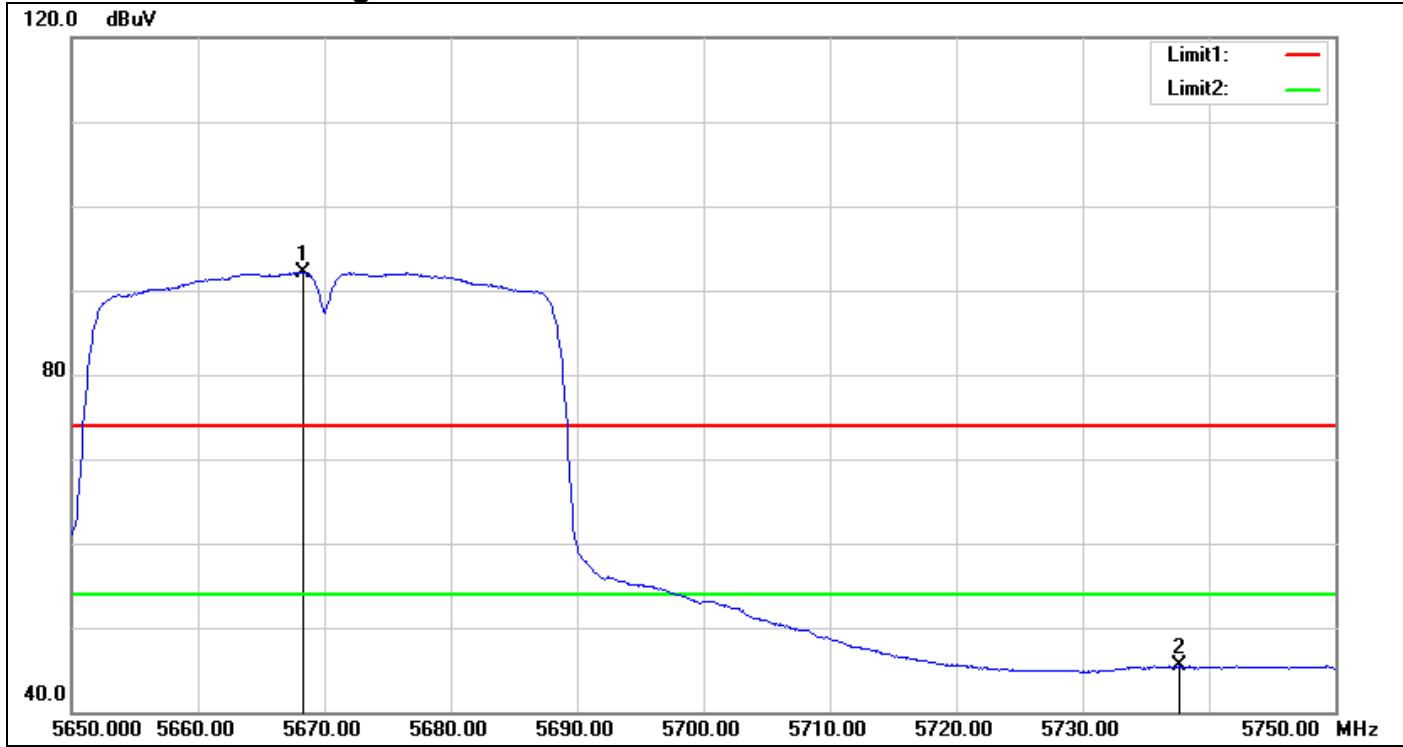

No.	Frequency (MHz)	Reading (dBuV)	Correct Factor(dB)	Result (dBuV)	Limit (dBuV)	Margin (dB)	Remark
1	5668.300	86.19	5.97	92.16	54.00	38.16	AVG
2	5737.700	39.21	6.26	45.47	54.00	-8.53	AVG

7.5 PEAK POWER SPECTRAL DENSITY

LIMIT

According to §15.407(a)

- (1) For the band 5.15-5.25 GHz, the peak power spectral density shall not exceed 11dBm in any 1MHz band.
- (2) For the band 5.25-5.35 GHz, the peak power spectral density shall not exceed 11dBm in any 1MHz band.

According to RSS-247,

- (1) The e.i.r.p. spectral density shall not exceed 10 dBm in any 1.0 MHz band.
- (2) The power spectral density shall not exceed 11 dBm in any 1.0 MHz band.

If transmitting antennas of directional gain greater than 6dBi are used, both the peak transmit power and the peak power spectral density shall be reduced by the amount in dB that the directional gain of the antenna exceeds 6dBi.

Test Configuration

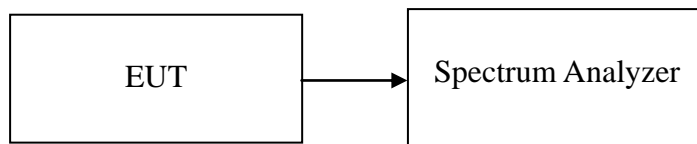

TEST PROCEDURE

1. Place the EUT on the table and set it in transmitting mode.
Remove the antenna from the EUT and then connect a low loss RF cable from the antenna port to the spectrum analyzer.
2. Set the spectrum analyzer as RBW = 1MHz, VBW = 3MHz, Span = Sweep= AUTO
3. Record the max. reading.
4. Repeat the above procedure until the measurements for all frequencies are completed

TEST RESULTS

No non-compliance noted

Test Data**Test mode: IEEE 802.11a mode / 5180 ~ 5240MHz**

Channel	Frequency (MHz)	PPSD (dBm)	Limit (dBm)	Result
Low	5180	4.46	11.00	PASS
Mid	5220	4.25	11.00	PASS
High	5240	3.29	11.00	PASS

Test mode: IEEE 802.11n HT 20 MHz mode / 5180 ~ 5240MHz

Channel	Frequency (MHz)	PPSD (dBm)	Limit (dBm)	Result
Low	5180	3.47	11.00	PASS
Mid	5220	3.04	11.00	PASS
High	5240	2.78	11.00	PASS

Test mode: IEEE 802.11n HT 40 MHz mode / 5190 ~ 5230MHz

Channel	Frequency (MHz)	PPSD (dBm)	Limit (dBm)	Result
Low	5190	0.87	11.00	PASS
High	5230	0.52	11.00	PASS

Test mode: IEEE 802.11a mode/ 5260 ~ 5320MHz

Channel	Frequency (MHz)	PPSD (dBm)	Limit (dBm)	Result
Low	5260	2.76	11.00	PASS
Mid	5280	2.92	11.00	PASS
High	5320	3.57	11.00	PASS

Test mode: IEEE 802.11n HT 20 MHz mode / 5260 ~ 5320MHz

Channel	Frequency (MHz)	PPSD (dBm)	Limit (dBm)	Result
Low	5260	2.52	11.00	PASS
Mid	5280	2.59	11.00	PASS
High	5320	3.71	11.00	PASS

Test mode: IEEE 802.11n HT 40 MHz mode / 5270 ~ 5310MHz

Channel	Frequency (MHz)	PPSD (dBm)	Limit (dBm)	Result
Low	5270	-0.68	11.00	PASS
High	5310	-0.16	11.00	PASS

Test mode: IEEE 802.11a mode / 5500 ~ 5700MHz

Channel	Frequency (MHz)	PPSD (dBm)	Limit (dBm)	Result
Low	5500	4.60	11.00	PASS
Mid	5580	4.01	11.00	PASS
High	5700	4.20	11.00	PASS

Test mode: IEEE 802.11n HT 20 MHz mode / 5500 ~ 5700MHz

Channel	Frequency (MHz)	PPSD (dBm)	Limit (dBm)	Result
Low	5500	4.51	11.00	PASS
Mid	5580	4.16	11.00	PASS
High	5700	4.60	11.00	PASS

Test mode: IEEE 802.11n HT 40 MHz mode / 5510 ~ 5670MHz

Channel	Frequency (MHz)	PPSD (dBm)	Limit (dBm)	Result
Low	5510	2.06	11.00	PASS
Mid	5550	1.52	11.00	PASS
High	5670	0.73	11.00	PASS

Test Plot

IEEE 802.11a mode / 5180 ~ 5240MHz

CH Low

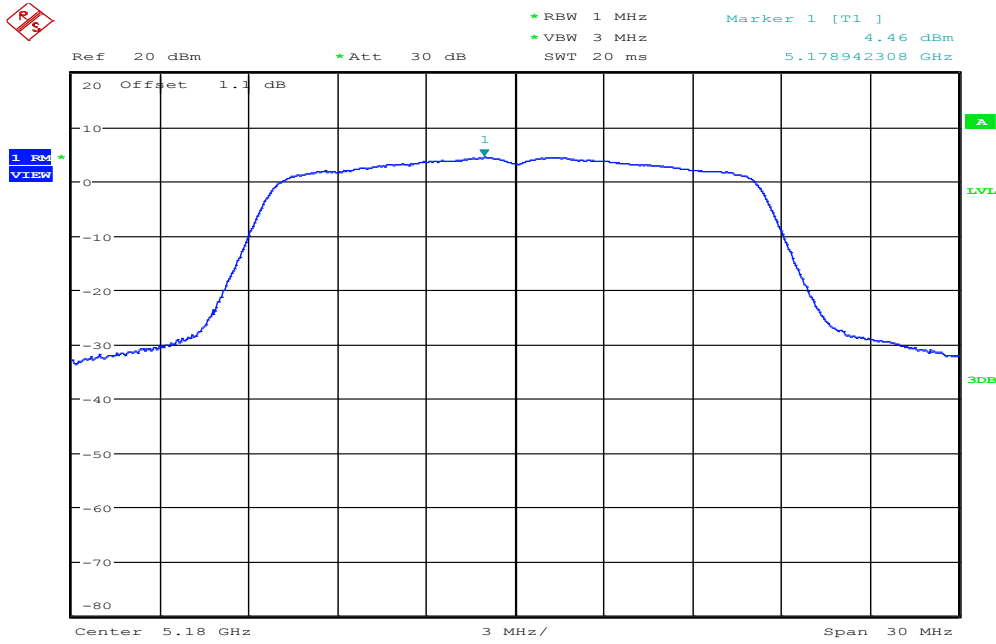

Date: 6.APR.2016 14:10:46

CH Mid

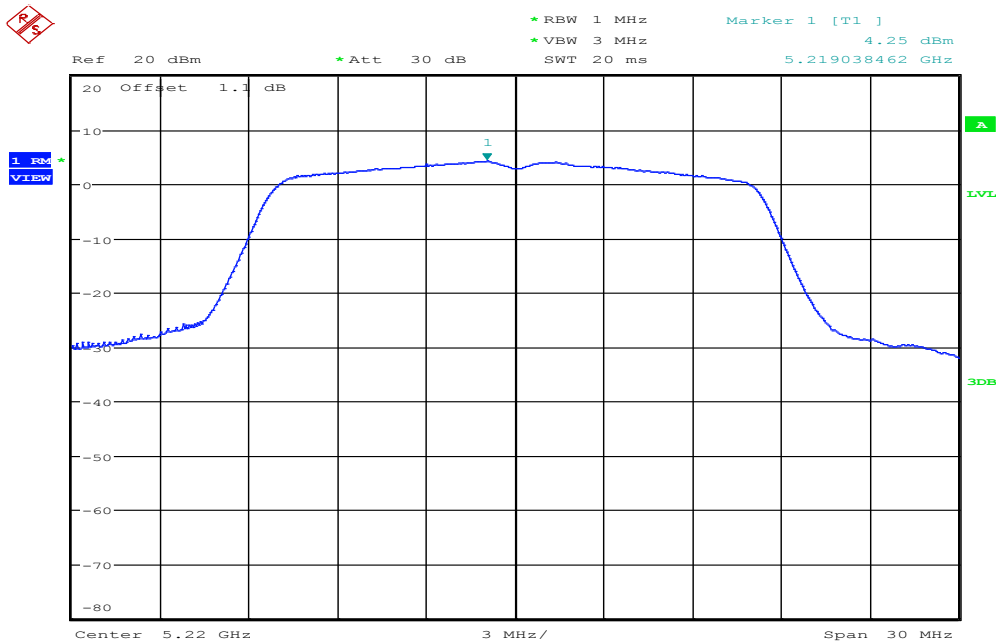

Date: 6.APR.2016 14:19:39

CH High

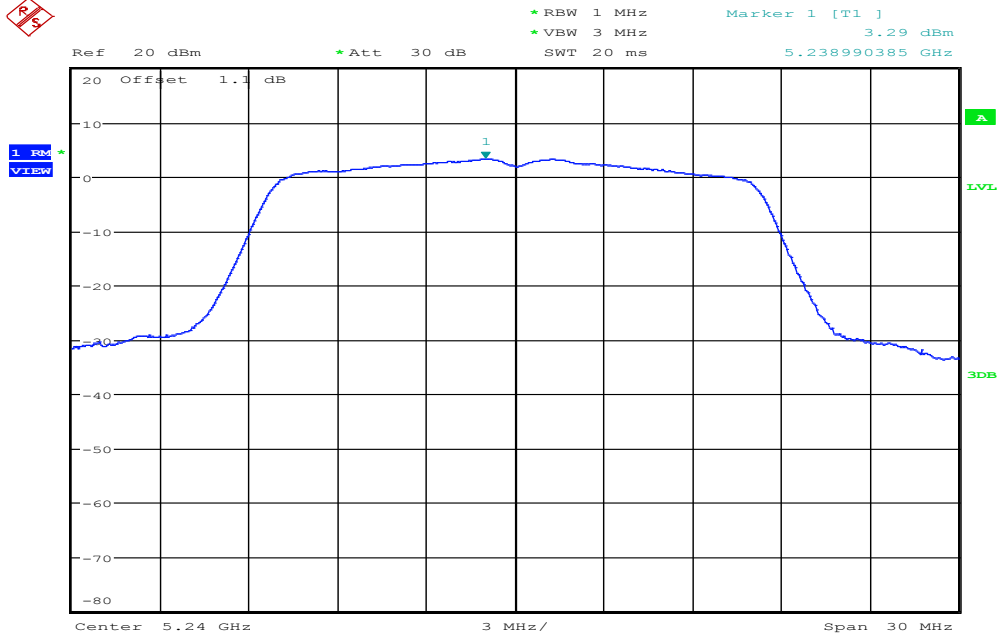

Date: 6.APR.2016 14:22:18

IEEE 802.11n HT 20 MHz mode / 5180 ~ 5240MHz

CH Low

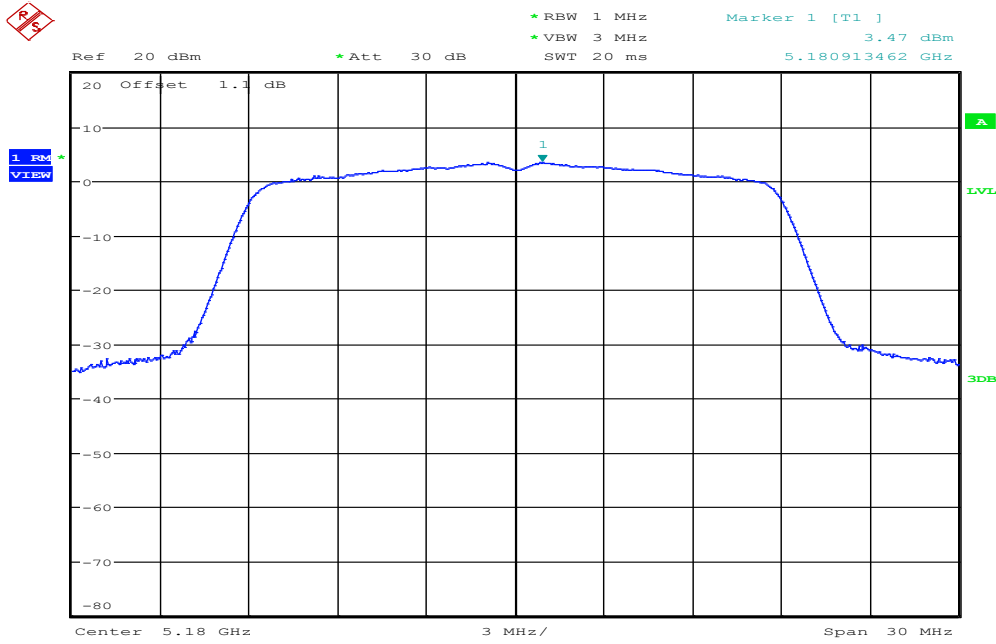

Date: 6.APR.2016 14:34:42

CH Mid

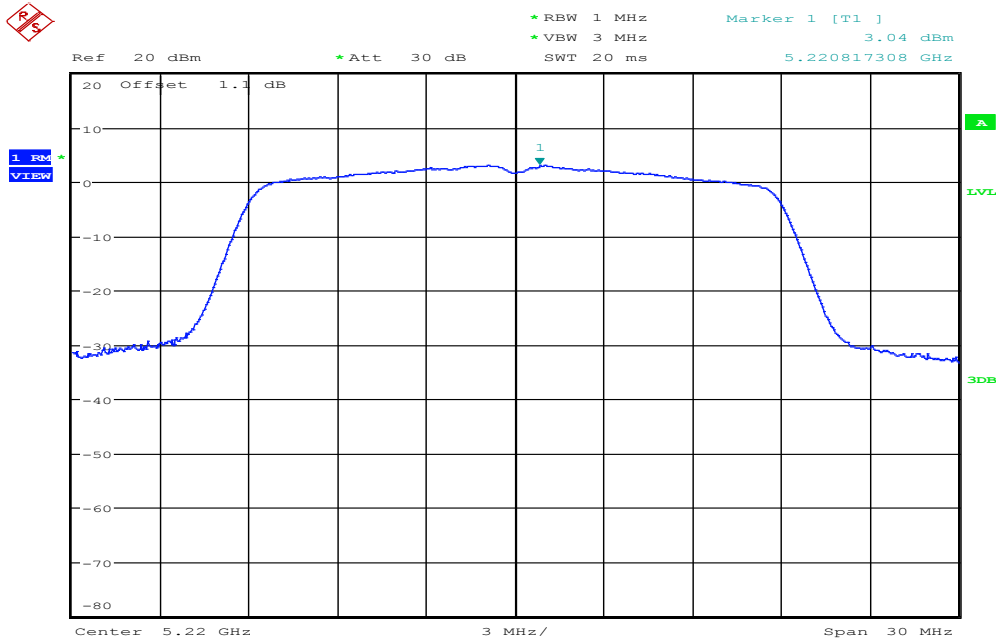

Date: 6.APR.2016 14:35:37

CH High

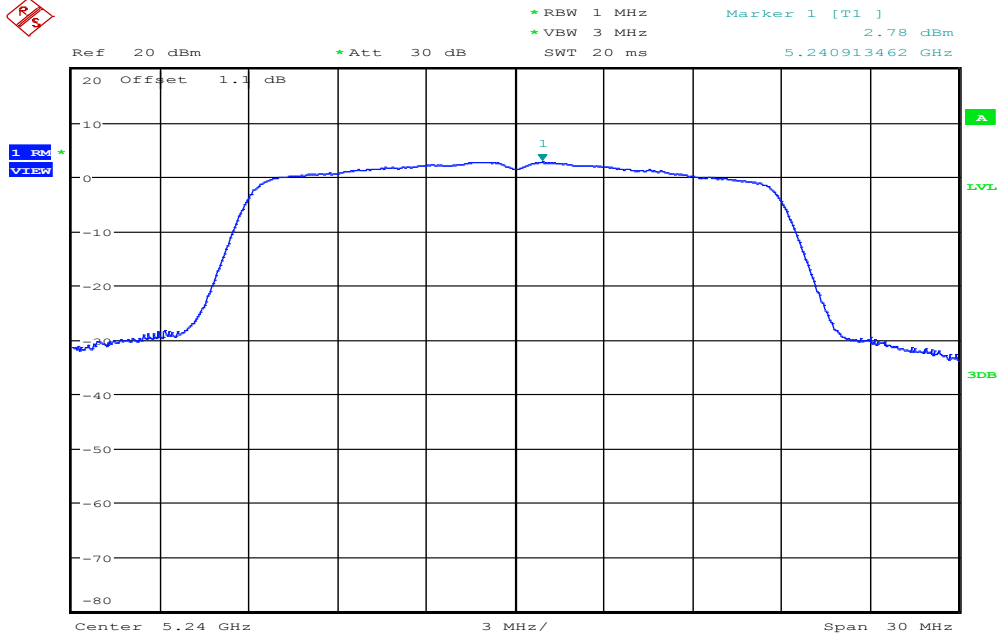

Date: 6.APR.2016 14:36:32

IEEE 802.11n HT 40 MHz mode / 5190 ~ 5230MHz

CH Low

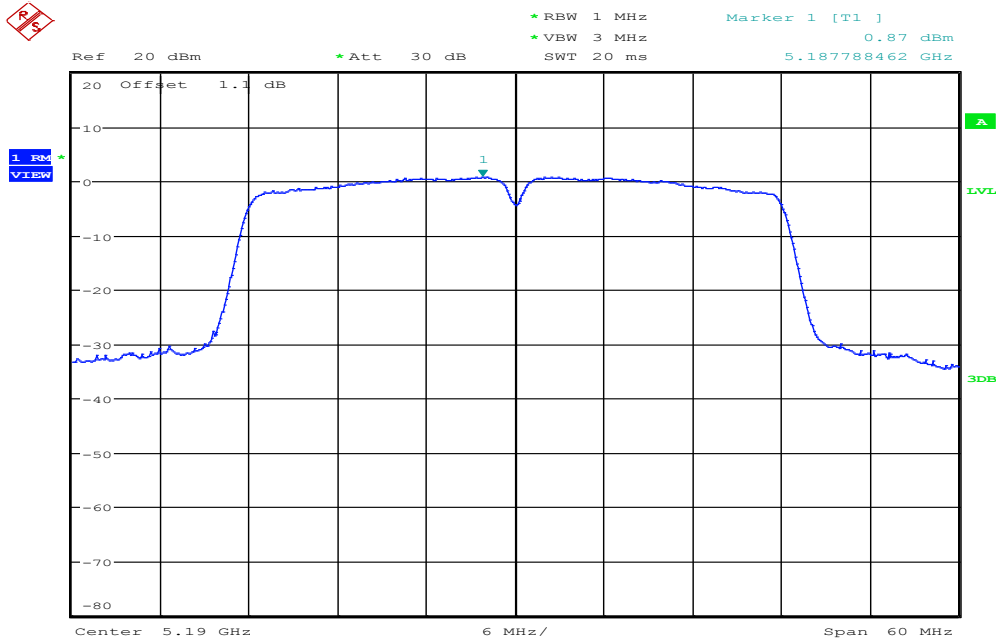

Date: 6.APR.2016 14:48:27

CH High

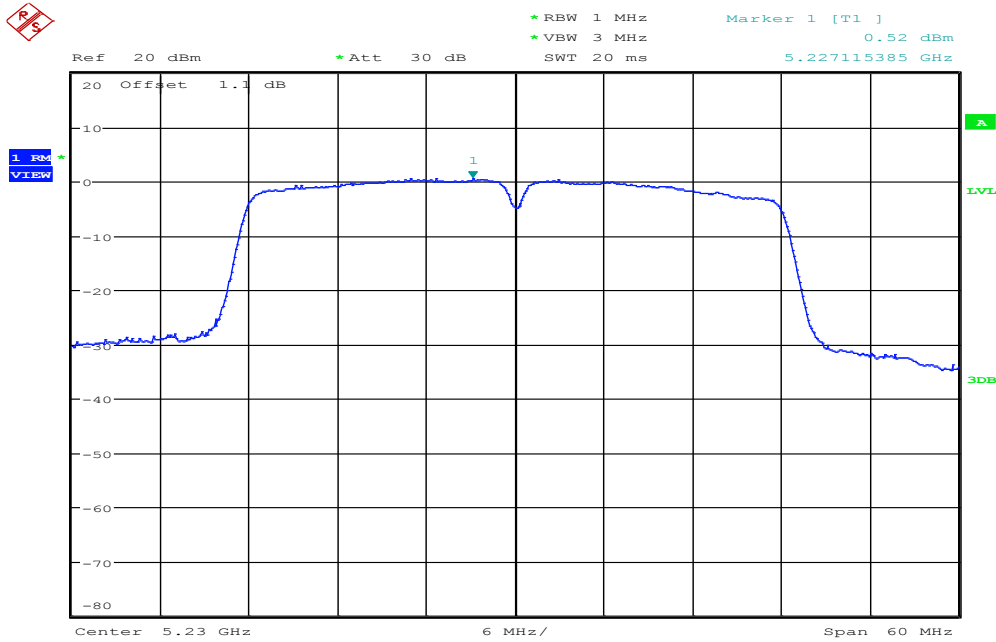

Date: 6.APR.2016 14:49:20

IEEE 802.11a mode / 5260 ~ 5320MHz

CH Low

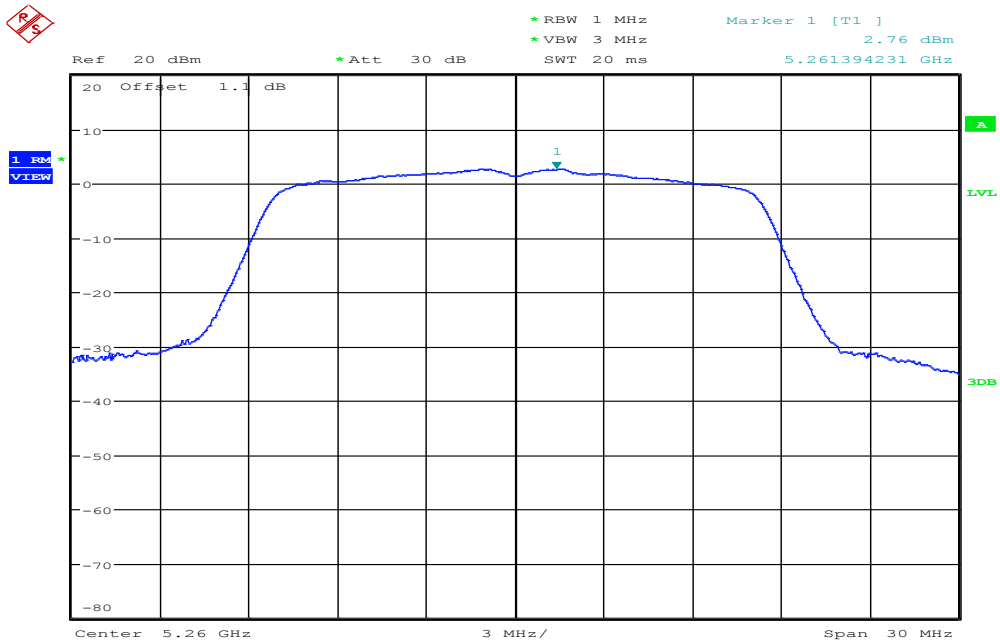

Date: 6.APR.2016 14:25:10

CH Mid

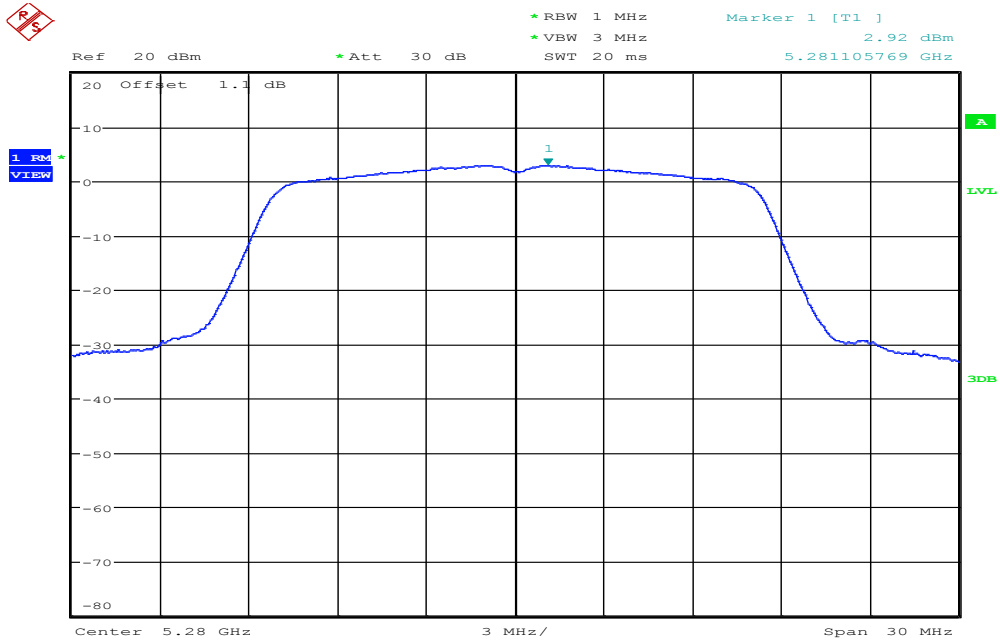

Date: 6.APR.2016 14:27:04

CH High

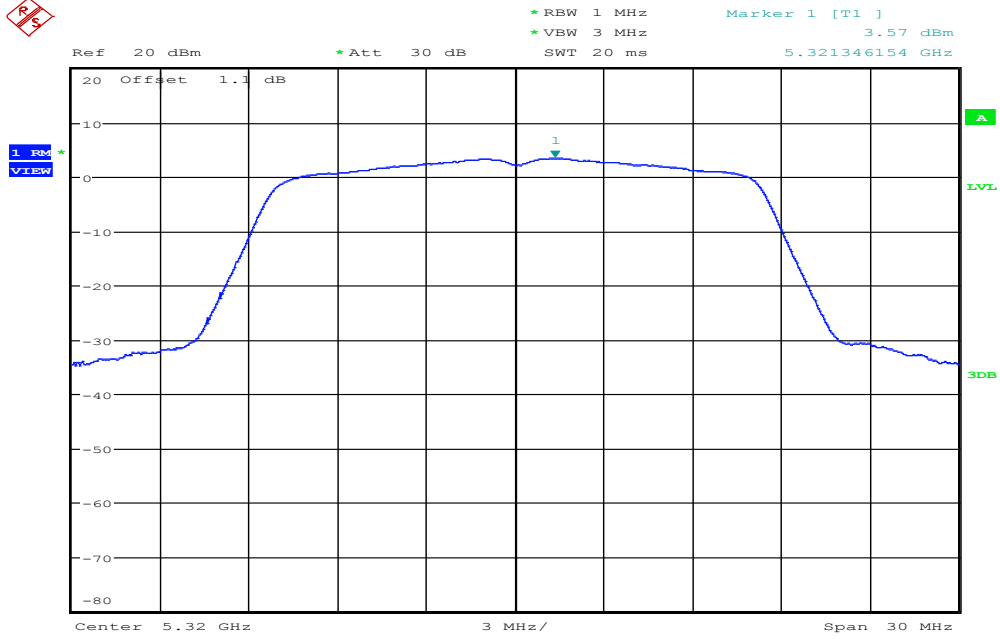

Date: 6.APR.2016 14:28:22

IEEE 802.11n HT 20 MHz mode / 5260 ~ 5320MHz

CH Low

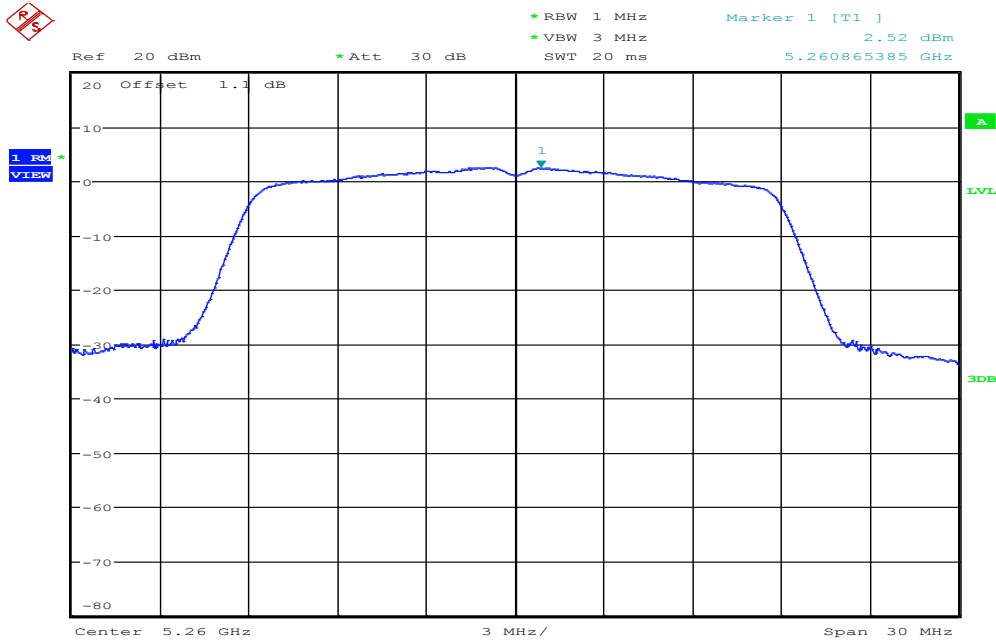

Date: 6.APR.2016 14:37:55

CH Mid

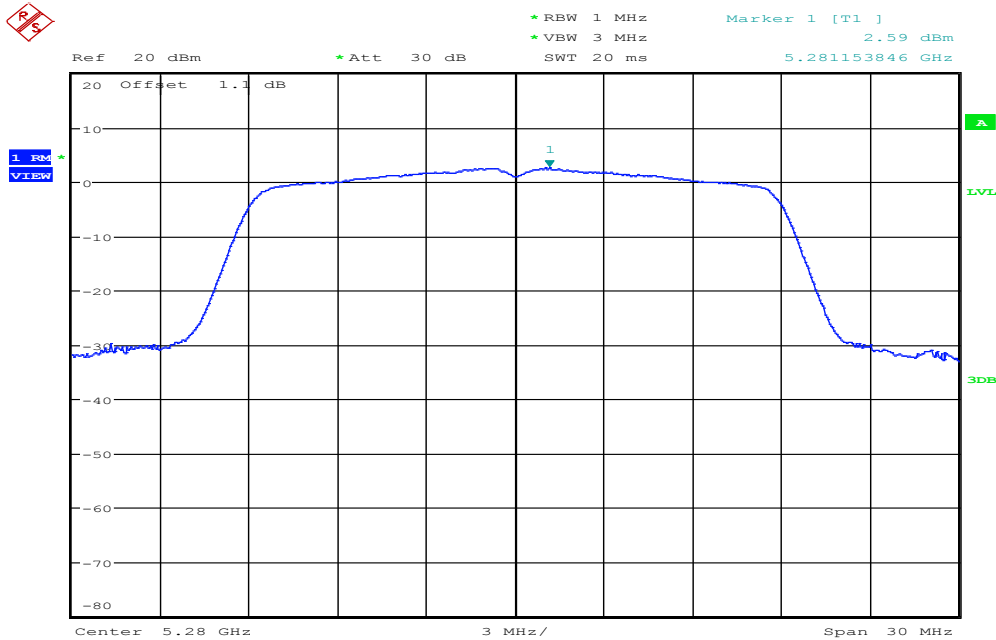

Date: 6.APR.2016 14:38:48

CH High

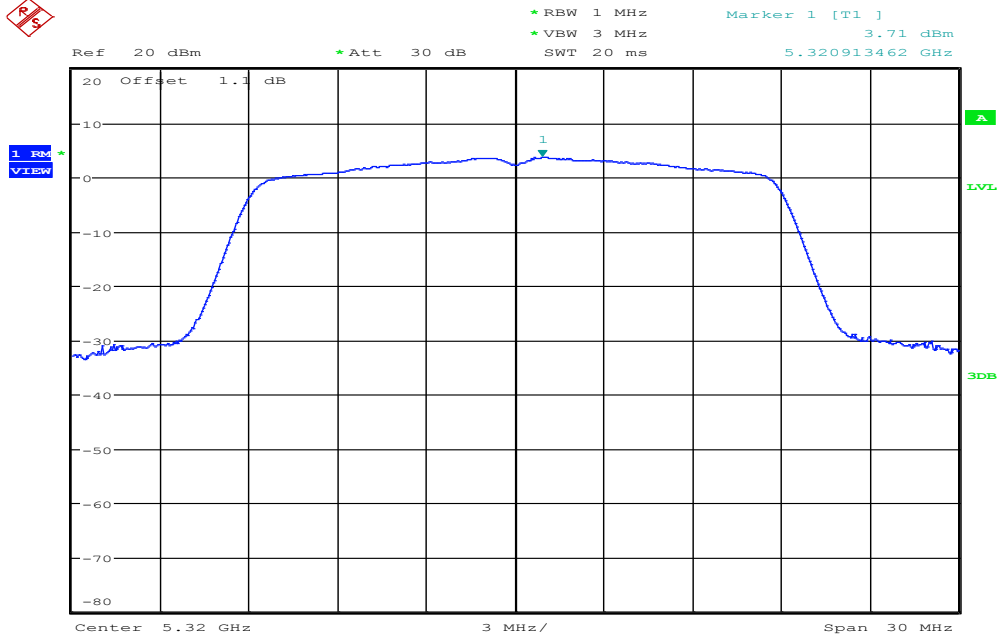

Date: 6.APR.2016 14:39:41

IEEE 802.11n HT 40 MHz mode / 5270 ~ 5310MHz

CH Low

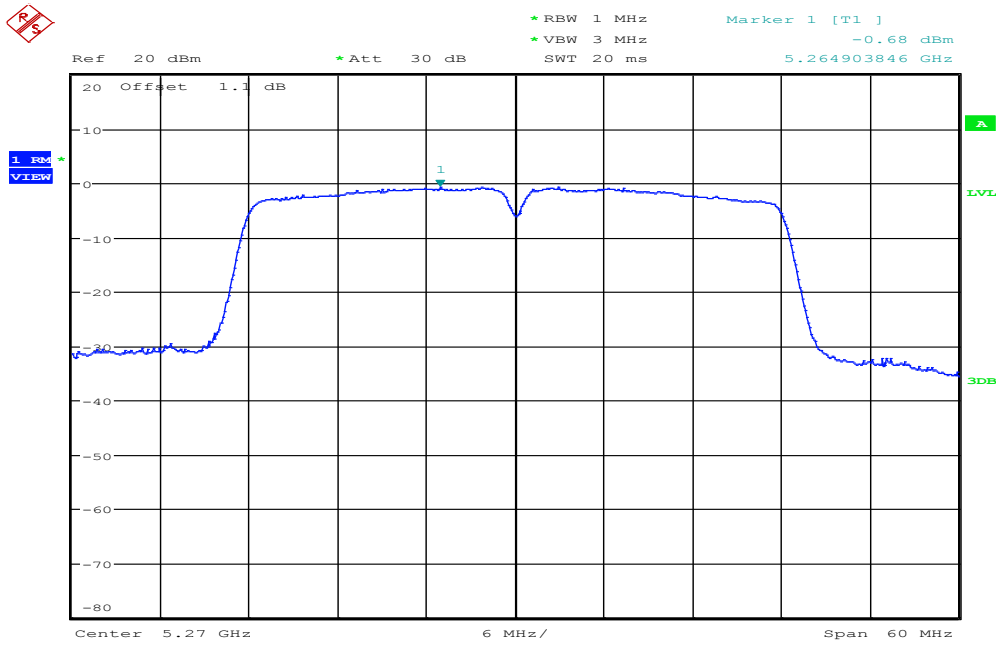

Date: 6.APR.2016 14:50:21

CH High

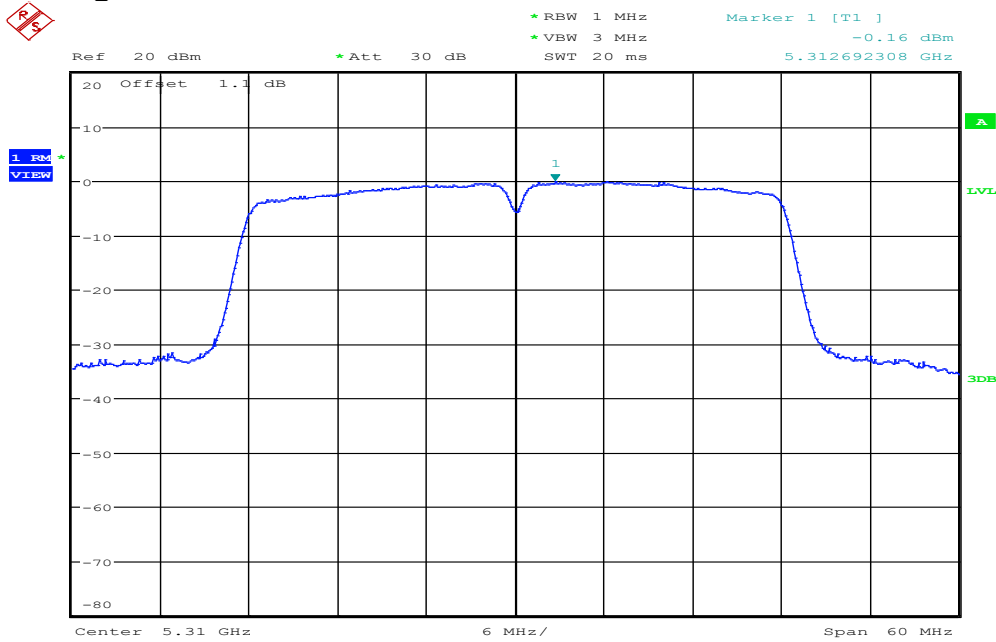

Date: 6.APR.2016 14:51:05

Test mode: IEEE 802.11a mode / 5500 ~ 5700MHz

CH Low

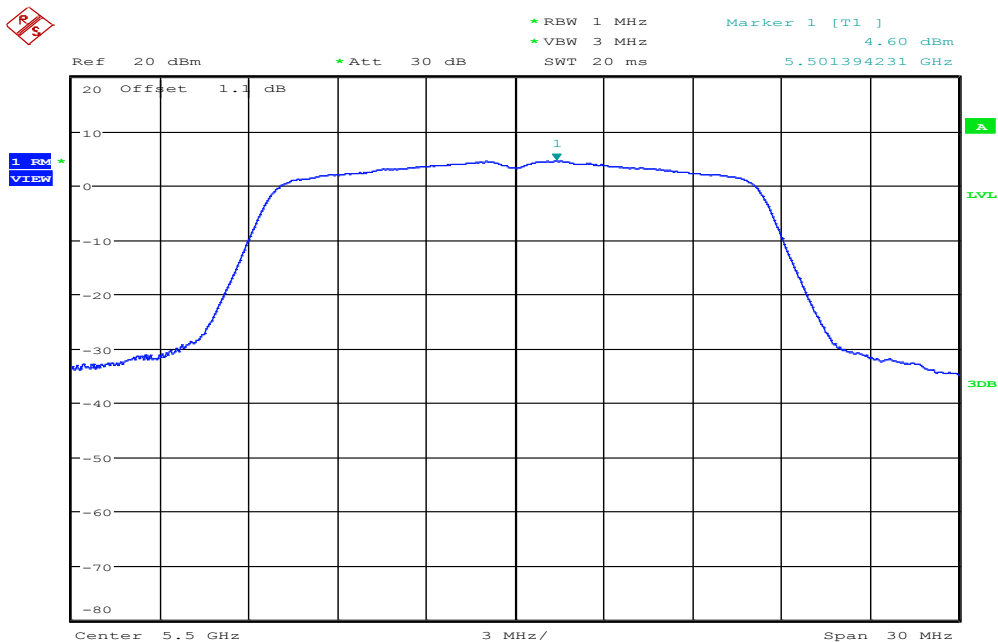

Date: 6.APR.2016 14:29:27

CH Mid

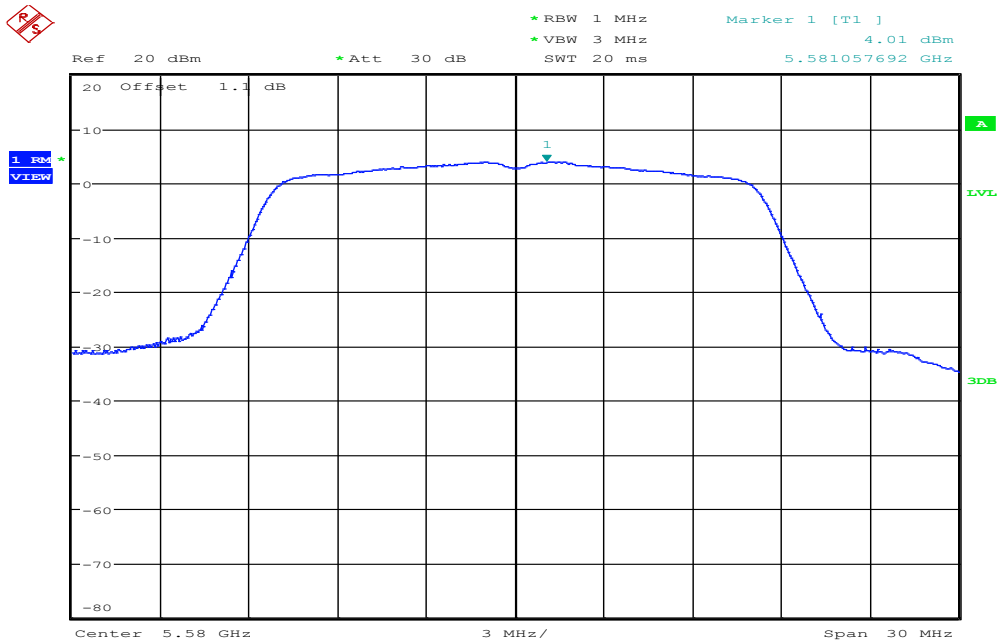

Date: 6.APR.2016 14:32:56

CH High

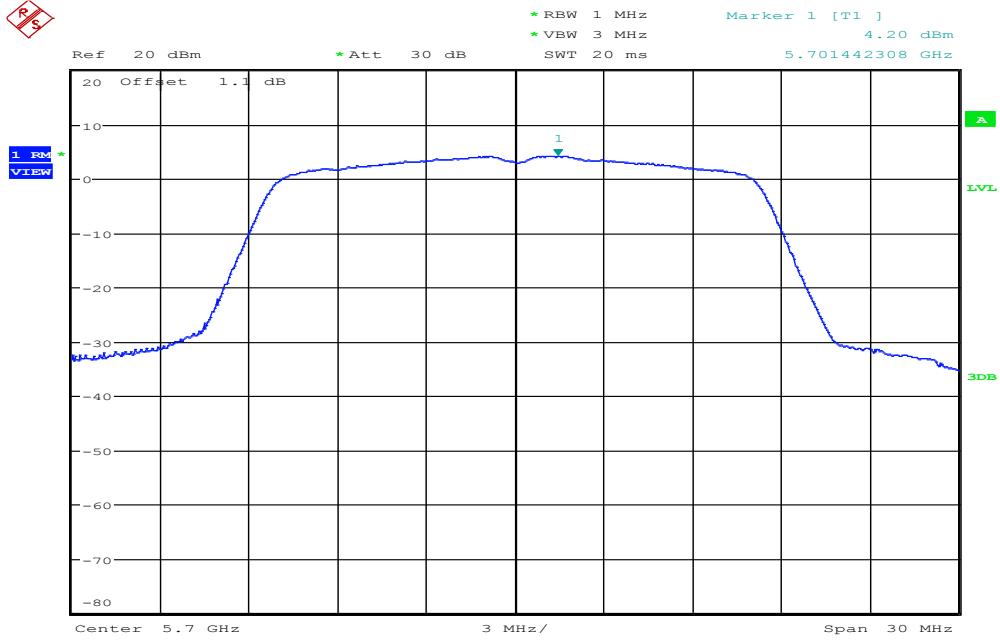

Date: 6.APR.2016 14:31:39

IEEE 802.11n HT 20 MHz mode / 5500 ~ 5700MHz

CH Low

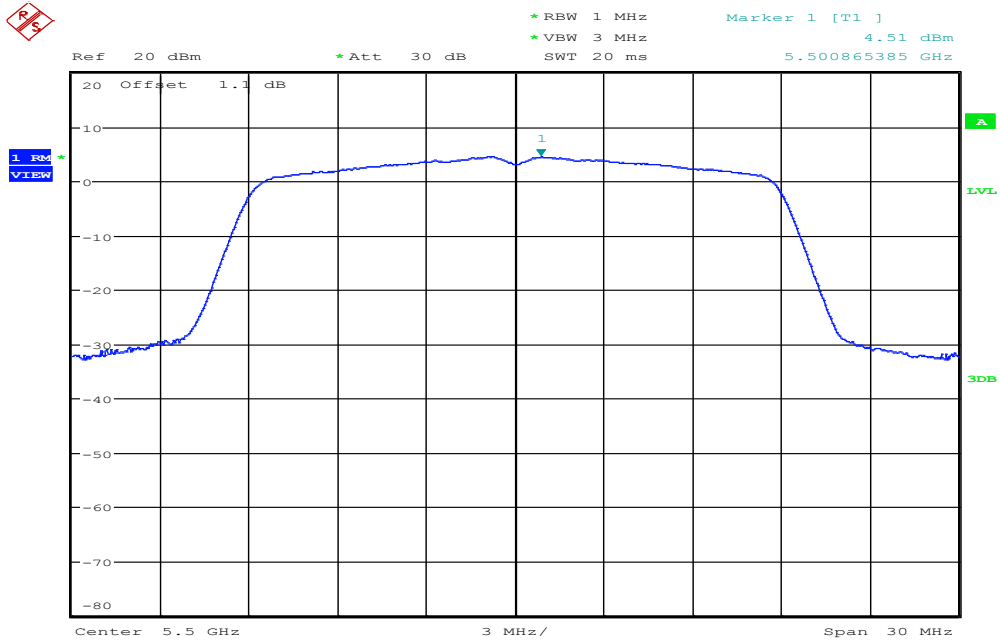

Date: 6.APR.2016 14:44:15

CH Mid

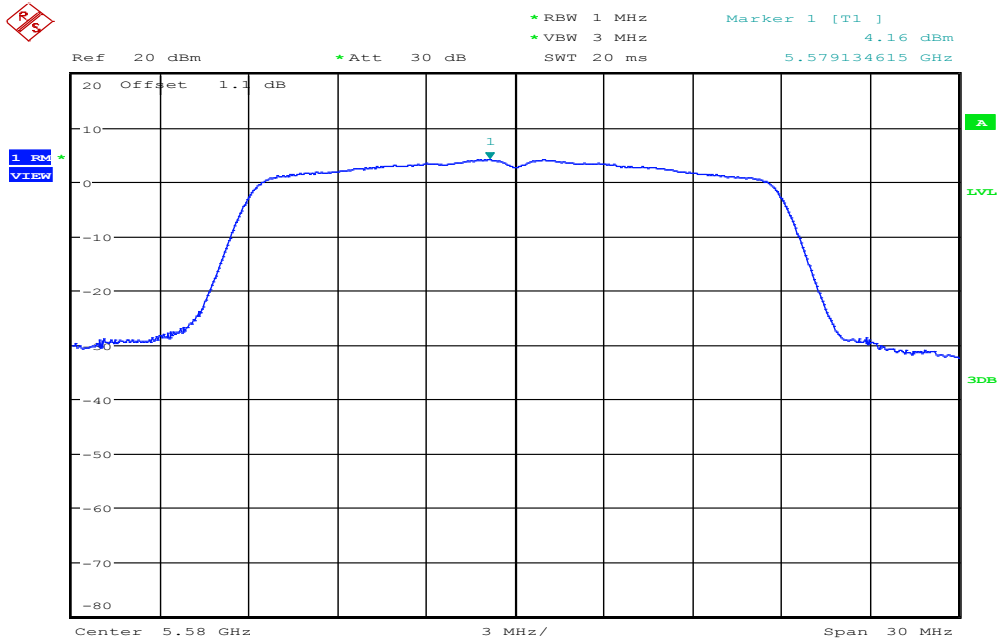

Date: 6.APR.2016 14:45:21

CH High

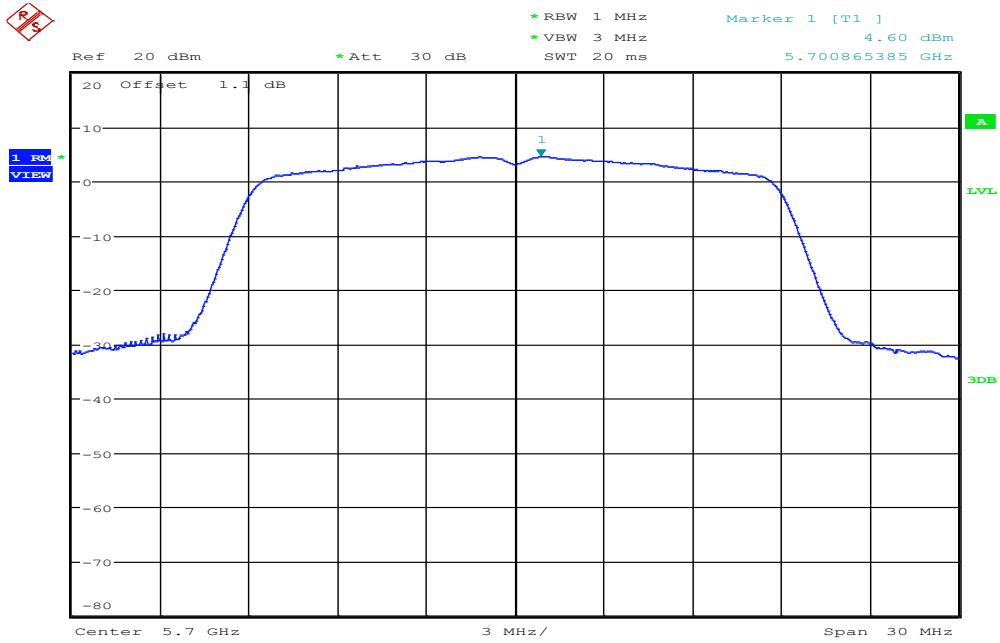

Date: 6.APR.2016 14:47:08

IEEE 802.11n HT 40 MHz mode / 5510 ~ 5670MHz

CH Low

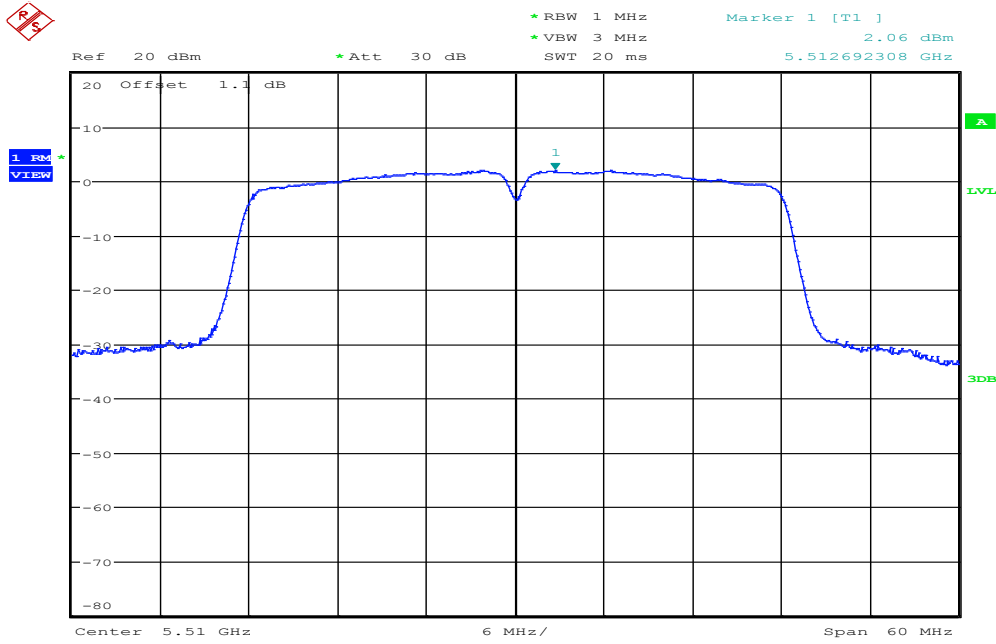

Date: 13.APR.2016 12:48:31

CH Mid

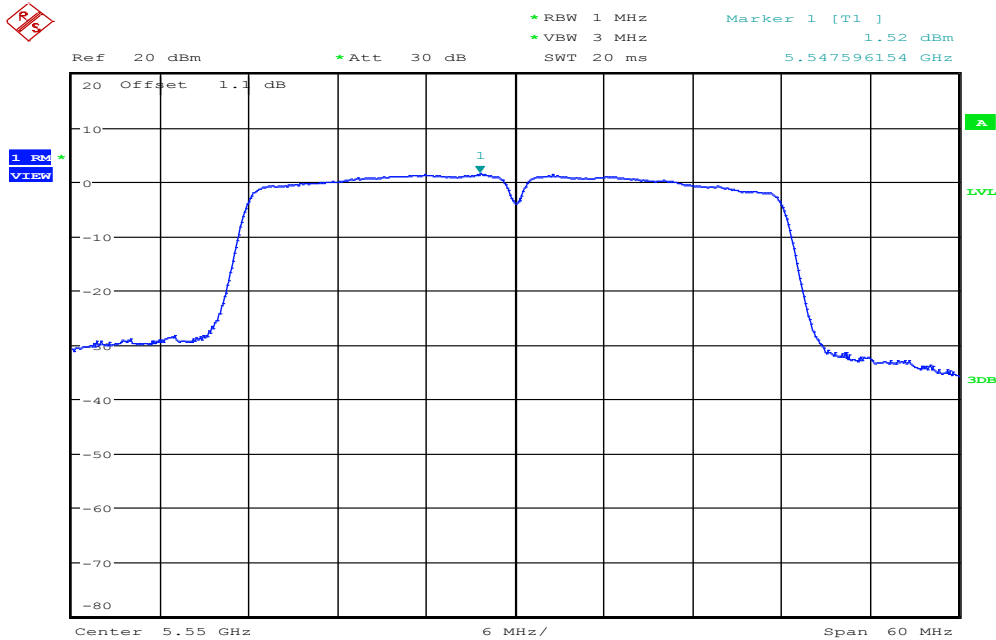

Date: 6.APR.2016 14:52:45

CH High

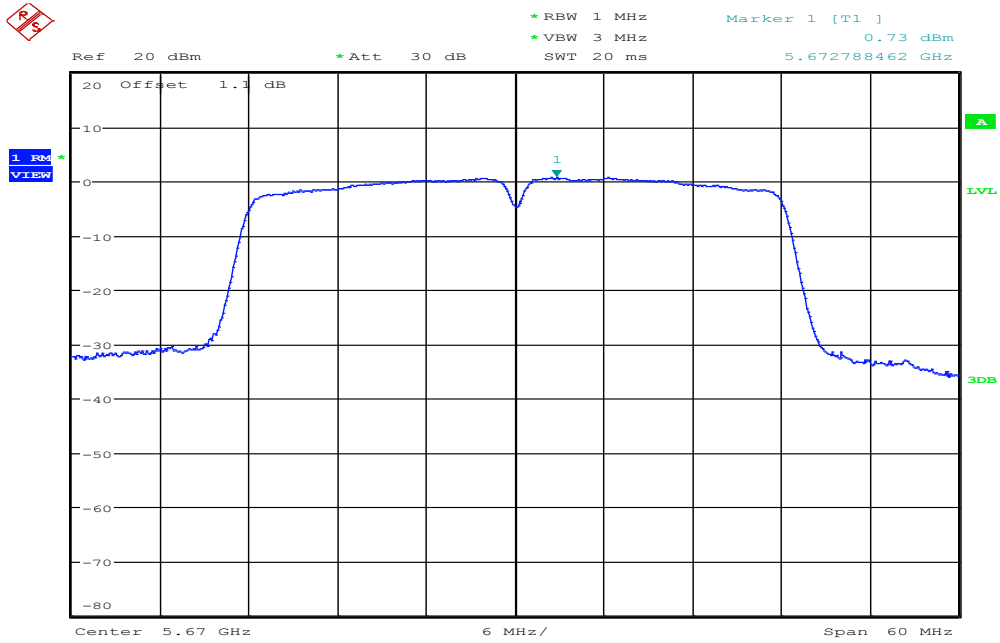

Date: 6.APR.2016 14:53:47

7.6 RADIATED UNDESIRABLE EMISSION

limit

All spurious emissions shall comply with the limits of §15.209(a) and RSS-Gen Table 2 & Table 5.

RSS-Gen Table 2 & Table 5: General Field Strength Limits for Transmitters and Receivers at Frequencies Above 30 MHz ^(Note)

Frequency (MHz)	Field Strength microvolts/m at 3 metres (watts, e.i.r.p.)	
	Transmitters	Receivers
30-88	100 (3 nW)	100 (3 nW)
88-216	150 (6.8 nW)	150 (6.8 nW)
216-960	200 (12 nW)	200 (12 nW)
Above 960	500 (75 nW)	500 (75 nW)

Note: *Measurements for compliance with limits in the above table may be performed at distances other than 3 metres, in accordance with Section 7.2.7.

Transmitting devices are not permitted in Table 1 bands or, unless stated otherwise, in TV bands (54-72 MHz, 76-88 MHz, 174-216 MHz, 470-608 MHz and 614-806 MHz).

RSS-Gen Table 6: General Field Strength Limits for Transmitters at Frequencies Below 30 MHz (Transmit)

Frequency	Field Strength (microvolts/m)	Magnetic H-Field (microamperes/m)	Measurement Distance (metres)
9-490 kHz	2,400/F (F in kHz)	2,400/377F (F in kHz)	3000
490-1,705 kHz	24,000/F (F in kHz)	24,000/377F (F in kHz)	30
1.705-30 MHz	30	N/A	30

Note: The emission limits for the bands 9-90 kHz and 110-490 kHz are based on measurements employing an average detector.

Test Configuration

9kHz ~ 30MHz

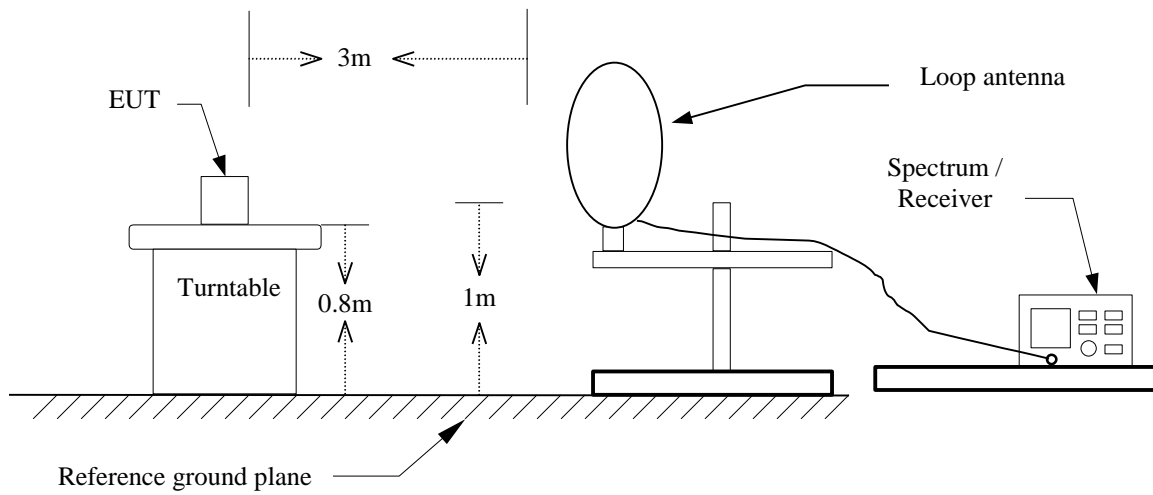

30MHz ~ 1GHz

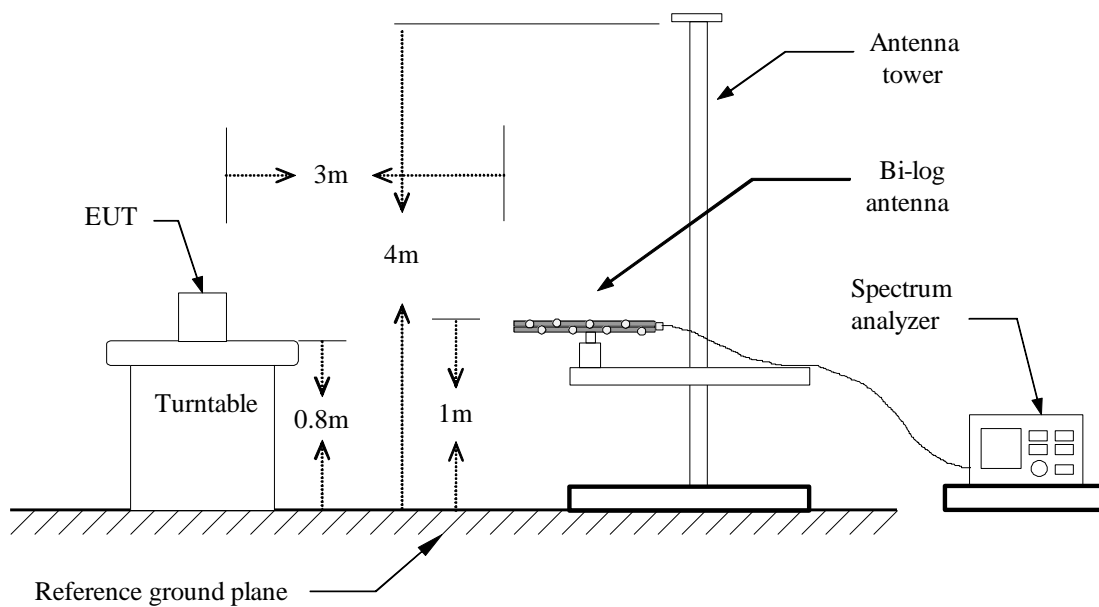

Above 1 GHz

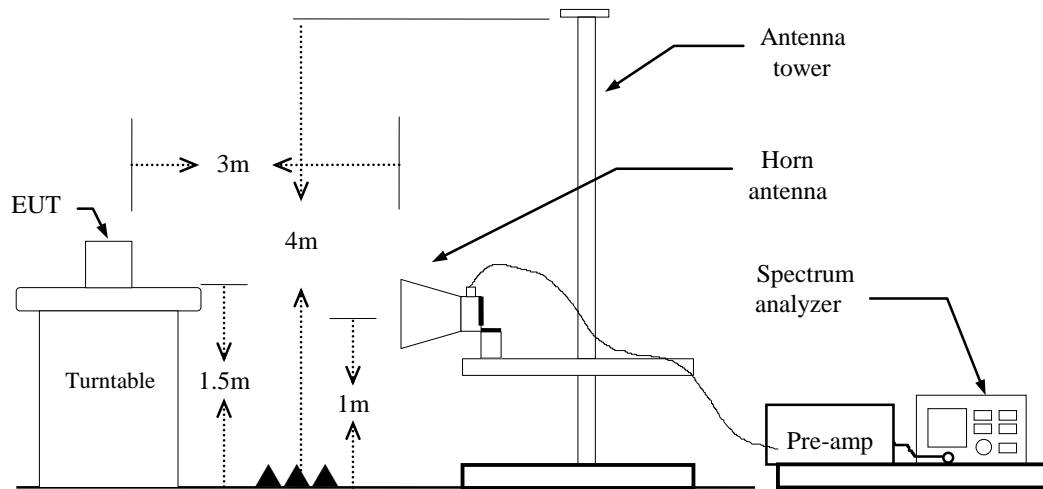

TEST PROCEDURE

1. The EUT is placed on a turntable, Above 1 GHz is 1.5m high and below 1 GHz is 0.8m high above ground plane.
2. The turntable shall be rotated for 360 degrees to determine the position of maximum emission level.
3. EUT is set 3m away from the receiving antenna, which is varied from 1m to 4m to find out the highest emissions.
4. Maximum procedure was performed on the six highest emissions to ensure EUT compliance.
5. And also, each emission was to be maximized by changing the polarization of receiving antenna both horizontal and vertical.
6. Set the spectrum analyzer in the following setting as:

Below 1GHz:

RBW=100kHz / VBW=300kHz / Sweep=AUTO

Above 1GHz:

(a) PEAK: RBW=VBW=1MHz / Sweep=AUTO

(b) AVERAGE: RBW=1MHz,
if duty cycle $\geq 98\%$, VBW=10Hz.

if duty cycle $< 98\%$ VBW=1/T.

IEEE 802.11a mode: $\geq 98\%$, VBW=10Hz

IEEE 802.11n HT 20 MHz mode: $\geq 98\%$, VBW=10Hz

IEEE 802.11n HT 40 MHz mode: $\geq 98\%$, VBW=10Hz

7. Repeat above procedures until the measurements for all frequencies are complete.
8. Result = Spectrum Reading + cable loss(spectrum to Amp) - Amp Gain + Cable loss(Amp to receive Ant)+ Receive Ant

Note: We checked every harmonics frequencies from Fundamental frequencies with reduced VBW, and we mark a point to prove pass or not if we find any emission. For this case, there are no emissions hidden in the noise floor.

Below 1 GHz

Operation Mode: Normal Link

Test Date: April 8, 2016

Temperature: 27°C

Tested by: Jason Lu

Humidity: 53% RH

Polarity: Ver. / Hor.

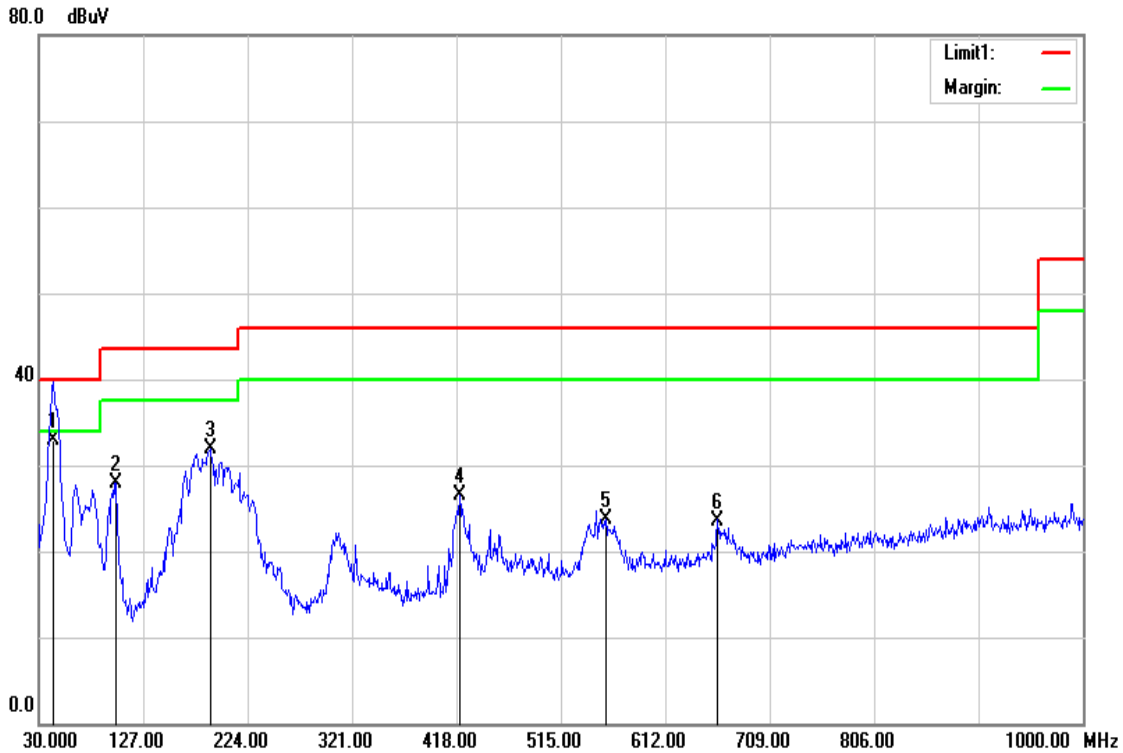

Frequency (MHz)	Reading (dBuV)	Correction Factor (dB/m)	Result (dBuV/m)	Limit (dBuV/m)	Margin (dB)	Remark	Ant.Pol. (H/V)
43.5800	50.21	-17.39	32.82	40.00	-7.18	Peak	V
101.7800	46.61	-18.72	27.89	43.50	-15.61	Peak	V
189.0800	48.48	-16.53	31.95	43.50	-11.55	Peak	V
420.9100	37.48	-11.07	26.41	46.00	-19.59	Peak	V
556.7100	32.05	-8.39	23.66	46.00	-22.34	Peak	V
660.5000	30.06	-6.46	23.60	46.00	-22.40	Peak	V

Remark:

- 1 Measuring frequencies from 30 MHz to the 1GHz.
- 2 Radiated emissions measured in frequency range from 30 MHz to 1000MHz were made with an instrument using peak/quasi-peak detector mode.
- 3 Quasi-peak test would be performed if the peak result were greater than the quasi-peak limit or as required by the applicant.
- 4 Measurements above show only up to 6 maximum emissions noted, or would be lesser, with " N/A " remark, if no specific emissions from the EUT are recorded (ie: margin>20dB from the applicable limit) and considered that's already beyond the background noise floor.
- 5 Margin (dB) = Remark result (dBuV/m) – Quasi-peak limit (dBuV/m).

Operation Mode: Normal Link
Temperature: 27°C
Humidity: 53% RH

Test Date: April 8, 2016
Tested by: Jason Lu
Polarity: Hor.

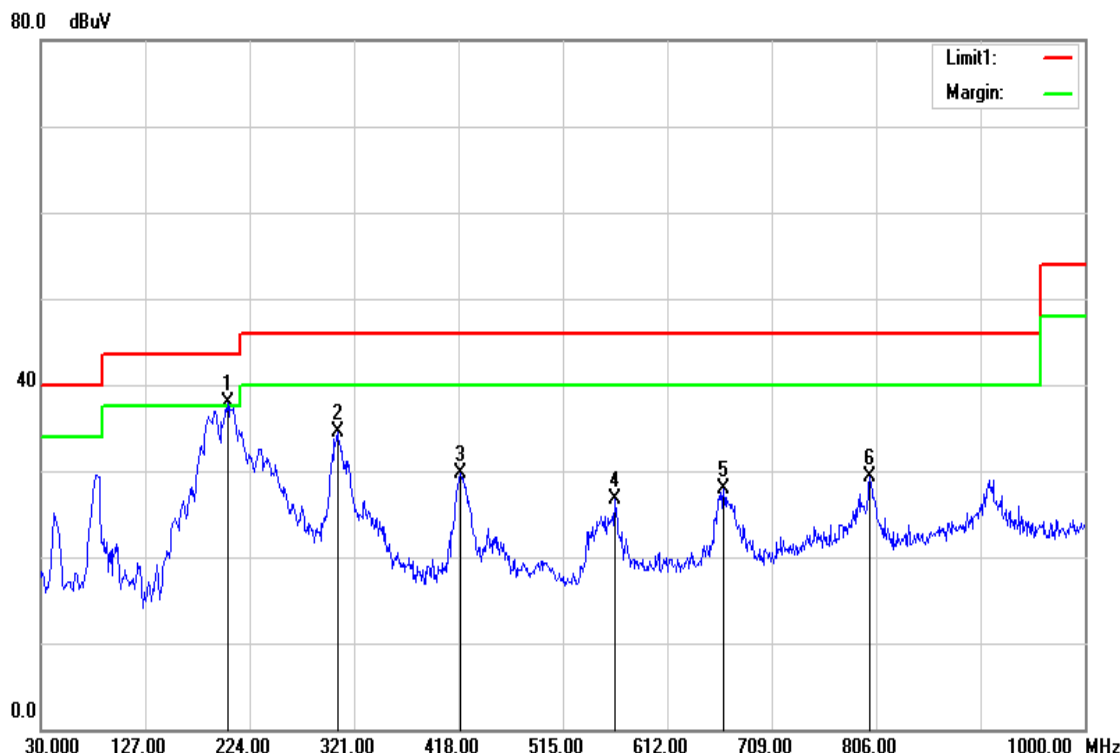

Frequency (MHz)	Reading (dBuV)	Correction Factor (dB/m)	Result (dBuV/m)	Limit (dBuV/m)	Margin (dB)	Remark	Ant.Pol. (H/V)
203.6300	53.73	-15.81	37.92	43.50	-5.58	Peak	H
305.4800	48.61	-14.09	34.52	46.00	-11.48	Peak	H
419.9400	40.86	-11.10	29.76	46.00	-16.24	Peak	H
563.5000	34.90	-8.29	26.61	46.00	-19.39	Peak	H
664.3800	34.26	-6.43	27.83	46.00	-18.17	Peak	H
800.1800	33.75	-4.50	29.25	46.00	-16.75	Peak	H

Remark:

1. No emission found between lowest internal used/generated frequency to 30MHz (9kHz~30MHz).
2. Radiated emissions measured in frequency range from 30 MHz to 1000MHz were made with an instrument using peak/quasi-peak detector mode.
3. Quasi-peak test would be performed if the peak result were greater than the quasi-peak limit or as required by the applicant.
4. Measurements above show only up to 6 maximum emissions noted, or would be lesser, with " N/A " remark, if no specific emissions from the EUT are recorded (ie: margin>20dB from the applicable limit) and considered that's already beyond the background noise floor.
5. Margin (dB) = Remark result (dBuV/m) – Quasi-peak limit (dBuV/m).

Above 1 GHz

U-NII-1

Tx / IEEE 802.11a mode / CH Low

Polarity: Vertical

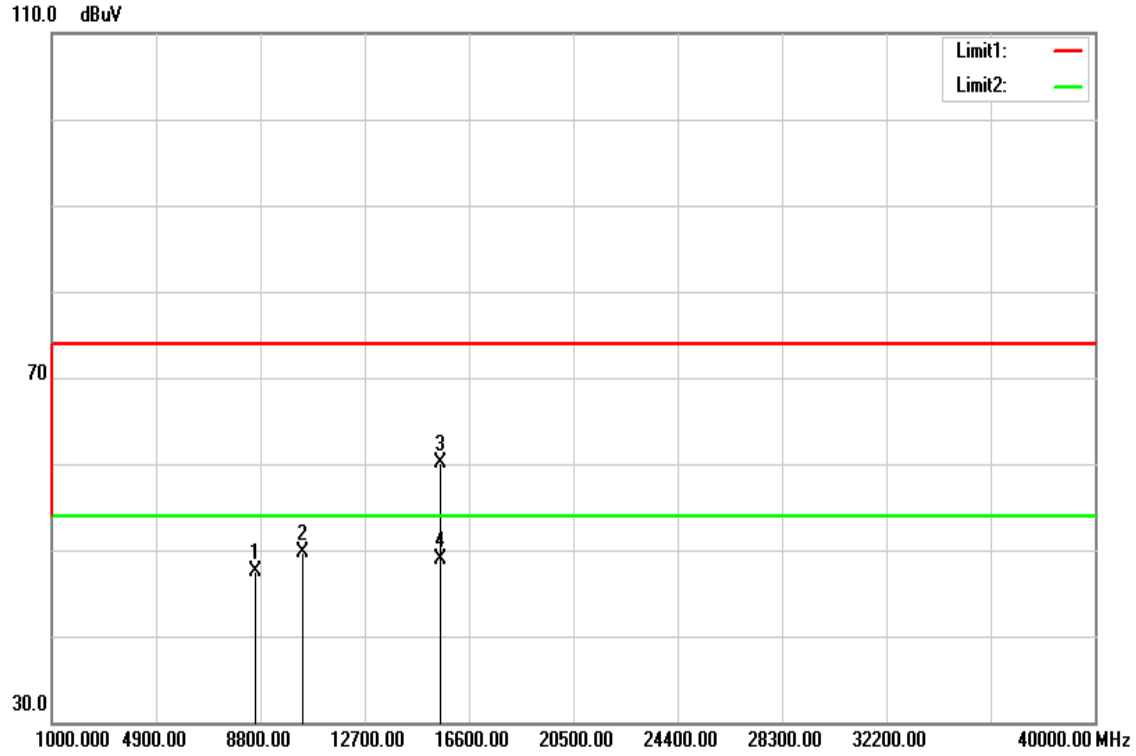

Polarity: Horizontal

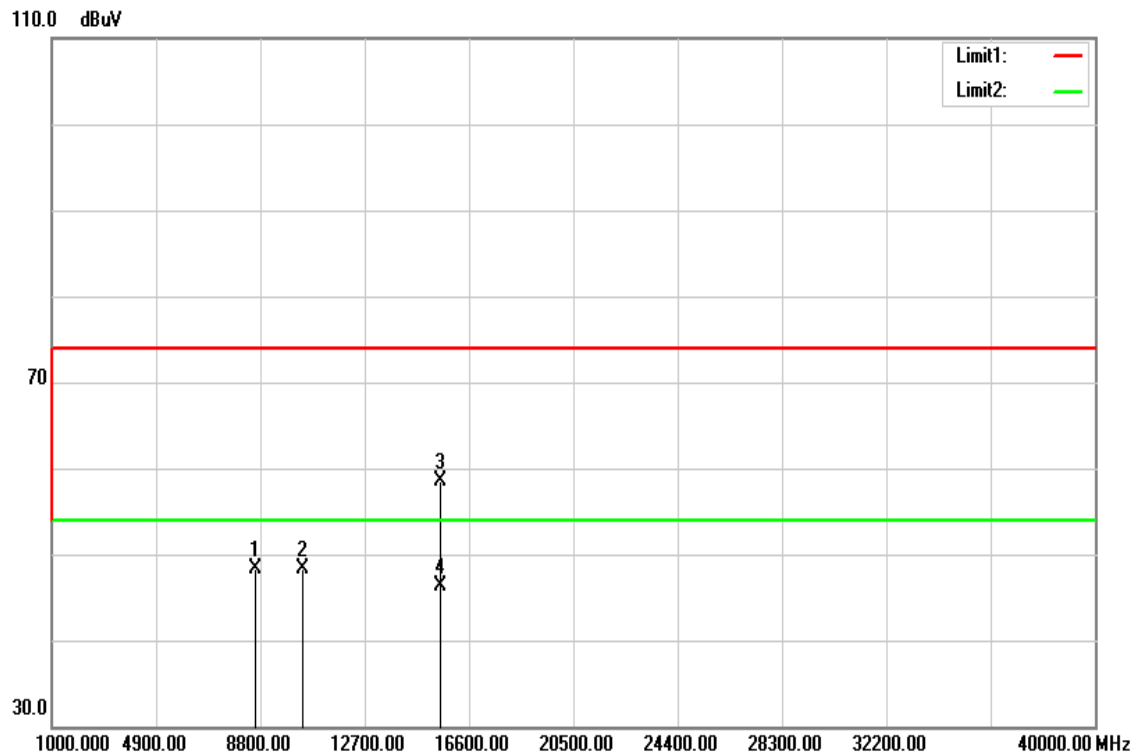

Operation Mode: Tx / IEEE 802.11a mode / CH Low

Test Date: April 13, 2016

Temperature: 27°C

Tested by: Jason Lu

Humidity: 53% RH

Polarity: Ver. / Hor.

Frequency (MHz)	Reading (dBuV)	Correction (dB/m)	Result (dBuV/m)	Limit (dBuV/m)	Margin (dB)	Remark	Ant.Pol. (H/V)
8603.000	33.81	13.69	47.50	74.00	-26.50	peak	V
10360.000	33.21	16.52	49.73	74.00	-24.27	peak	V
15540.000	41.16	19.04	60.20	74.00	-13.80	peak	V
15540.000	29.84	19.04	48.88	54.00	-5.12	AVG	V
N/A							
8606.000	34.57	13.69	48.26	74.00	-25.74	peak	H
10360.000	31.86	16.52	48.38	74.00	-25.62	peak	H
15540.000	39.47	19.04	58.51	74.00	-15.49	peak	H
15540.000	27.20	19.04	46.24	54.00	-7.76	AVG	H
N/A							

Remark:

1. Measuring frequencies from 1 GHz to the 10th harmonic of highest fundamental frequency.
2. Radiated emissions measured in frequency above 1000MHz were made with an instrument using peak/average detector mode.
3. Average test would be performed if the peak result were greater than the average limit.
4. Data of measurement within this frequency range shown " --- " in the table above means the reading of emissions are attenuated more than 20dB below the permissible limits or the field strength is too small to be measured.
5. Measurements above show only up to 6 maximum emissions noted, or would be lesser, with " N/A " remark, if no specific emissions from the EUT are recorded (ie: margin>20dB from the applicable limit) and considered that's already beyond the background noise floor.
6. Margin (dB) = Remark result (dBuV/m) – Average limit (dBuV/m).

Tx / IEEE 802.11a mode / CH Mid

Polarity: Vertical

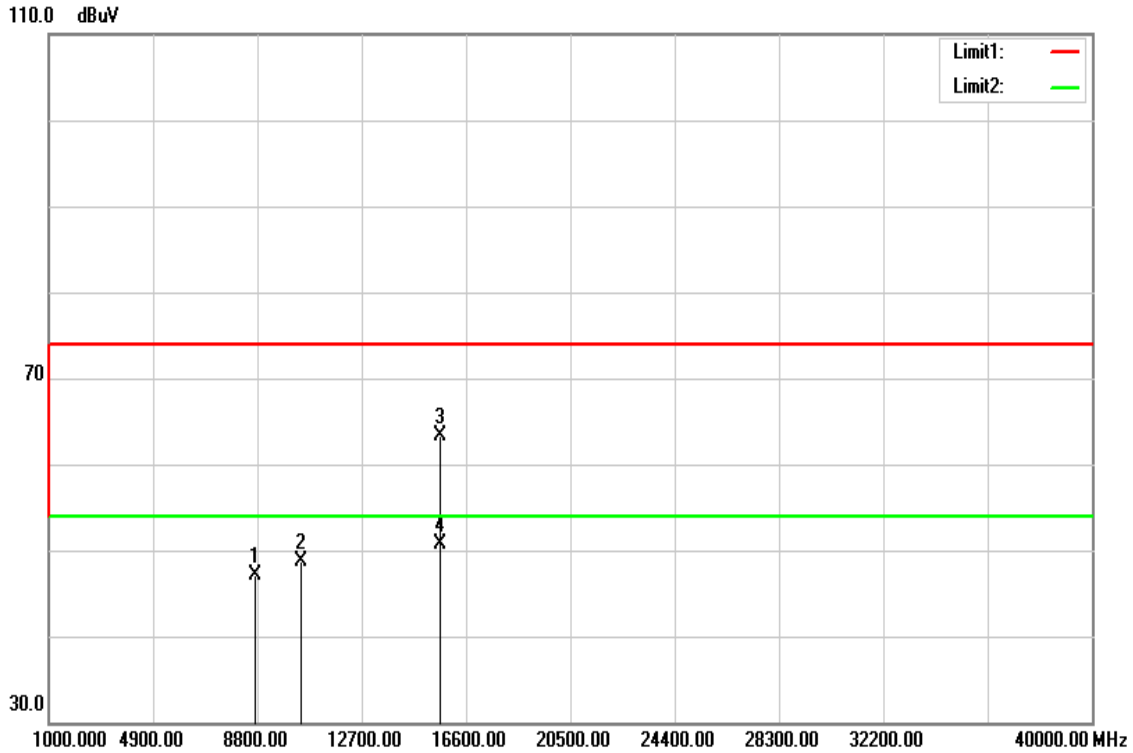

Polarity: Horizontal

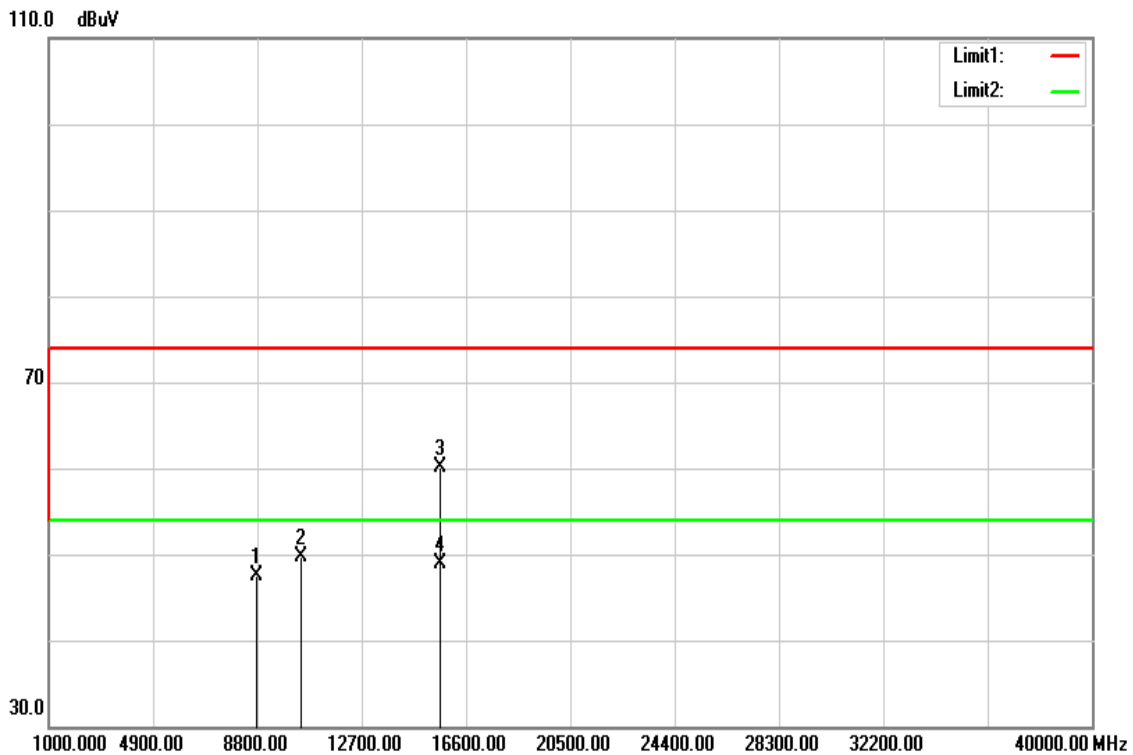

Operation Mode: Tx / IEEE 802.11a mode / CH Mid

Test Date: April 13, 2016

Temperature: 27°C

Tested by: Jason Lu

Humidity: 53% RH

Polarity: Ver. / Hor.

Frequency (MHz)	Reading (dBuV)	Correction (dB/m)	Result (dBuV/m)	Limit (dBuV/m)	Margin (dB)	Remark	Ant.Pol. (H/V)
8701.000	33.34	13.73	47.07	74.00	-26.93	peak	V
10440.000	31.83	16.89	48.72	74.00	-25.28	peak	V
15660.000	44.22	19.14	63.36	74.00	-10.64	peak	V
15660.000	31.66	19.14	50.80	54.00	-3.20	AVG	V
N/A							
8766.000	33.74	13.76	47.50	74.00	-26.50	peak	H
10440.000	32.84	16.89	49.73	74.00	-24.27	peak	H
15660.000	41.06	19.14	60.20	74.00	-13.80	peak	H
15660.000	29.74	19.14	48.88	54.00	-5.12	AVG	H
N/A							

Remark:

1. Measuring frequencies from 1 GHz to the 10th harmonic of highest fundamental frequency.
2. Radiated emissions measured in frequency above 1000MHz were made with an instrument using peak/average detector mode.
3. Average test would be performed if the peak result were greater than the average limit.
4. Data of measurement within this frequency range shown " --- " in the table above means the reading of emissions are attenuated more than 20dB below the permissible limits or the field strength is too small to be measured.
5. Measurements above show only up to 6 maximum emissions noted, or would be lesser, with " N/A " remark, if no specific emissions from the EUT are recorded (ie: margin>20dB from the applicable limit) and considered that's already beyond the background noise floor.
6. Margin (dB) = Remark result (dBuV/m) – Average limit (dBuV/m).

Tx / IEEE 802.11a mode / CH High

Polarity: Vertical

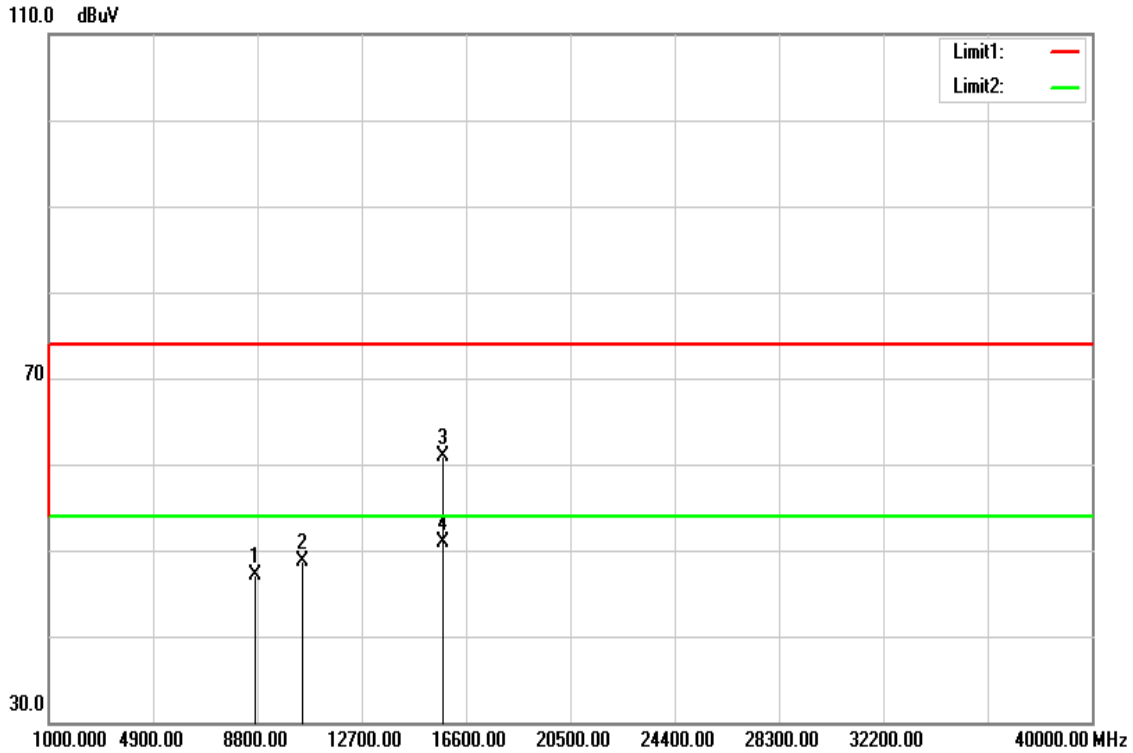

Polarity: Horizontal

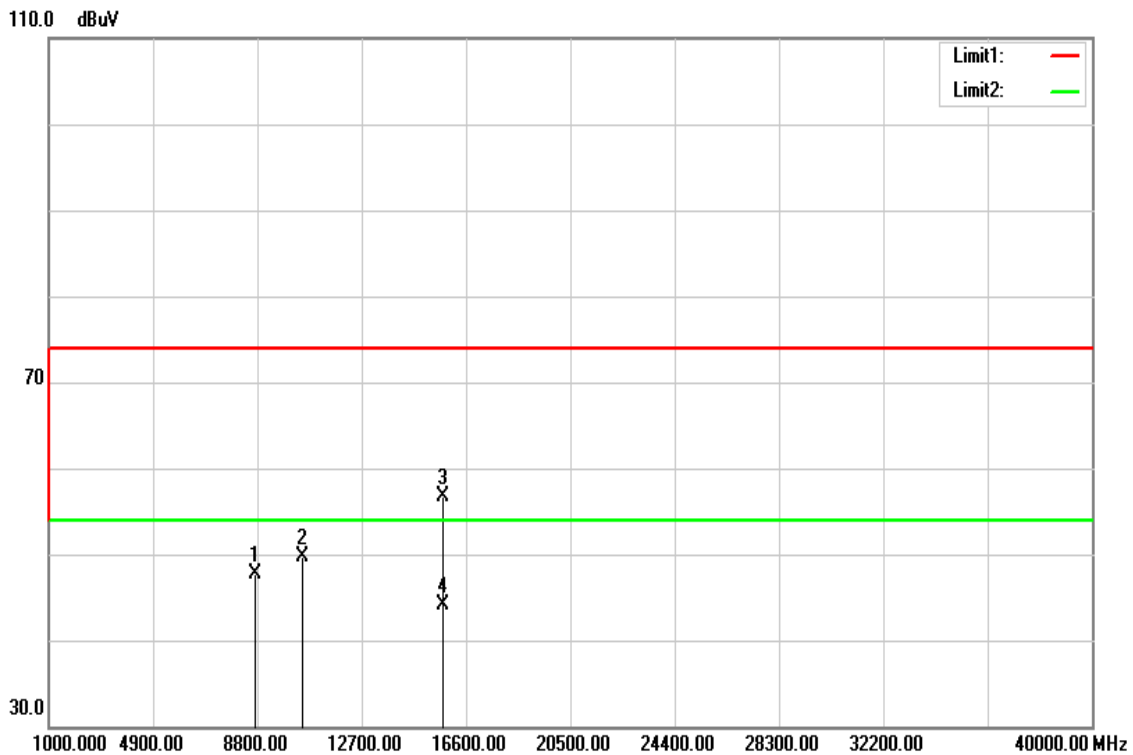

Operation Mode: Tx / IEEE 802.11a mode / CH High **Test Date:** April 13, 2016
Temperature: 27°C **Tested by:** Jason Lu
Humidity: 53% RH **Polarity:** Ver. / Hor.

Frequency (MHz)	Reading (dBuV)	Correction (dB/m)	Result (dBuV/m)	Limit (dBuV/m)	Margin (dB)	Remark	Ant.Pol. (H/V)
8699.000	33.40	13.73	47.13	74.00	-26.87	peak	V
10480.000	31.63	17.07	48.70	74.00	-25.30	peak	V
15720.000	41.71	19.19	60.90	74.00	-13.10	peak	V
15720.000	31.68	19.19	50.87	54.00	-3.13	AVG	V
N/A							
8705.000	34.02	13.73	47.75	74.00	-26.25	peak	H
10480.000	32.71	17.07	49.78	74.00	-24.22	peak	H
15720.000	37.46	19.19	56.65	74.00	-17.35	peak	H
15720.000	24.96	19.19	44.15	54.00	-9.85	AVG	H
N/A							

Remark:

1. Measuring frequencies from 1 GHz to the 10th harmonic of highest fundamental frequency.
2. Radiated emissions measured in frequency above 1000MHz were made with an instrument using peak/average detector mode.
3. Average test would be performed if the peak result were greater than the average limit.
4. Data of measurement within this frequency range shown " --- " in the table above means the reading of emissions are attenuated more than 20dB below the permissible limits or the field strength is too small to be measured.
5. Measurements above show only up to 6 maximum emissions noted, or would be lesser, with " N/A " remark, if no specific emissions from the EUT are recorded (ie: margin>20dB from the applicable limit) and considered that's already beyond the background noise floor.
6. Margin (dB) = Remark result (dBuV/m) – Average limit (dBuV/m).

Tx / IEEE 802.11n HT 20 MHz mode / CH Low

Polarity: Vertical

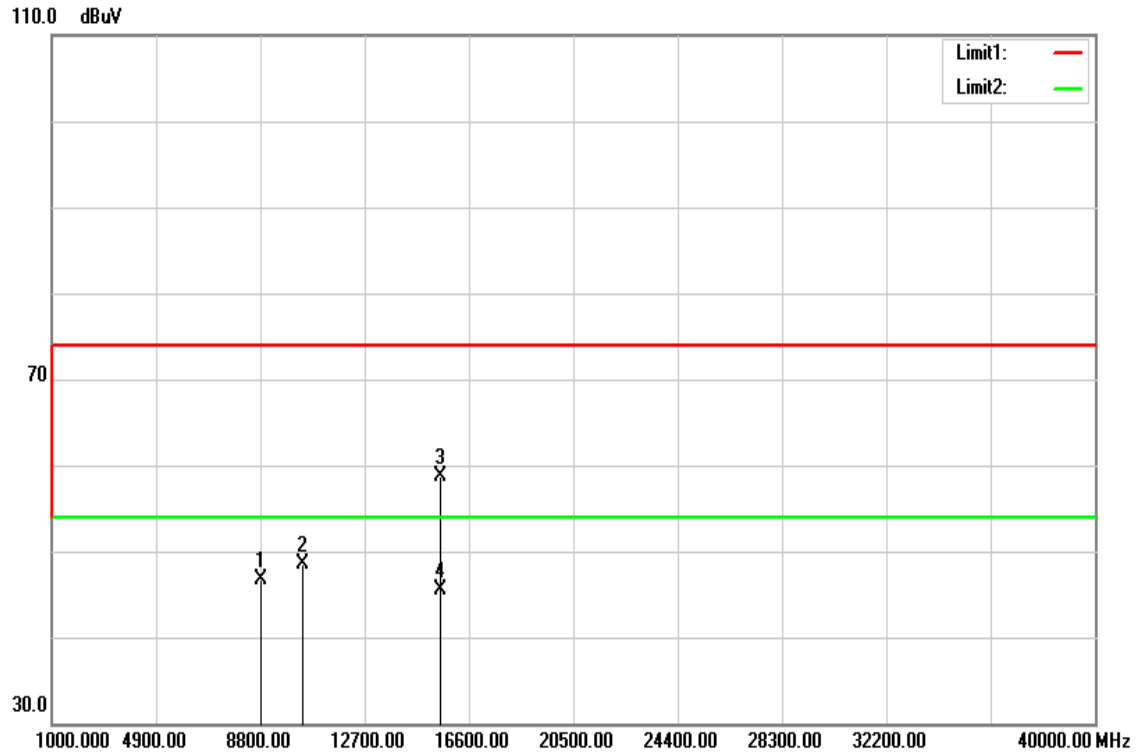

Polarity: Horizontal

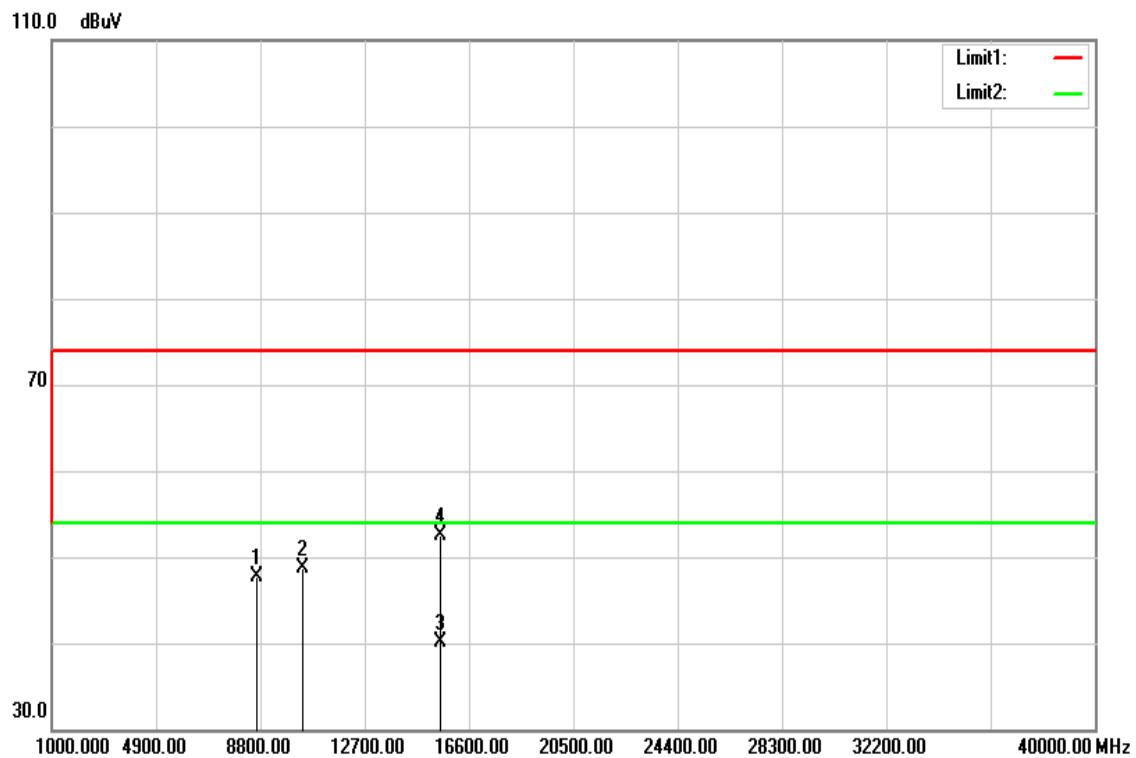

Operation Mode: Tx / IEEE 802.11n HT 20 MHz mode / CH Low
Temperature: 27°C
Humidity: 53% RH

Test Date: April 13, 2016
Tested by: Jason Lu
Polarity: Ver. / Hor.

Frequency (MHz)	Reading (dBuV)	Correction (dB/m)	Result (dBuV/m)	Limit (dBuV/m)	Margin (dB)	Remark	Ant.Pol. (H/V)
8841.000	32.91	13.80	46.71	74.00	-27.29	peak	V
10360.000	31.97	16.52	48.49	74.00	-25.51	peak	V
15540.000	39.64	19.04	58.68	74.00	-15.32	peak	V
15540.000	26.50	19.04	45.54	54.00	-8.46	AVG	V
N/A							
8665.000	34.03	13.72	47.75	74.00	-26.25	peak	H
10360.000	32.10	16.52	48.62	74.00	-25.38	peak	H
15540.000	20.97	19.04	40.01	74.00	-33.99	peak	H
15540.000	33.55	19.04	52.59	54.00	-1.41	AVG	H
N/A							

Remark:

1. Measuring frequencies from 1 GHz to the 10th harmonic of highest fundamental frequency.
2. Radiated emissions measured in frequency above 1000MHz were made with an instrument using peak/average detector mode.
3. Average test would be performed if the peak result were greater than the average limit.
4. Data of measurement within this frequency range shown " --- " in the table above means the reading of emissions are attenuated more than 20dB below the permissible limits or the field strength is too small to be measured.
5. Measurements above show only up to 6 maximum emissions noted, or would be lesser, with " N/A " remark, if no specific emissions from the EUT are recorded (ie: margin>20dB from the applicable limit) and considered that's already beyond the background noise floor.
6. Margin (dB) = Remark result (dBuV/m) – Average limit (dBuV/m).

Tx / IEEE 802.11n HT 20 MHz mode / CH Mid

Polarity: Vertical

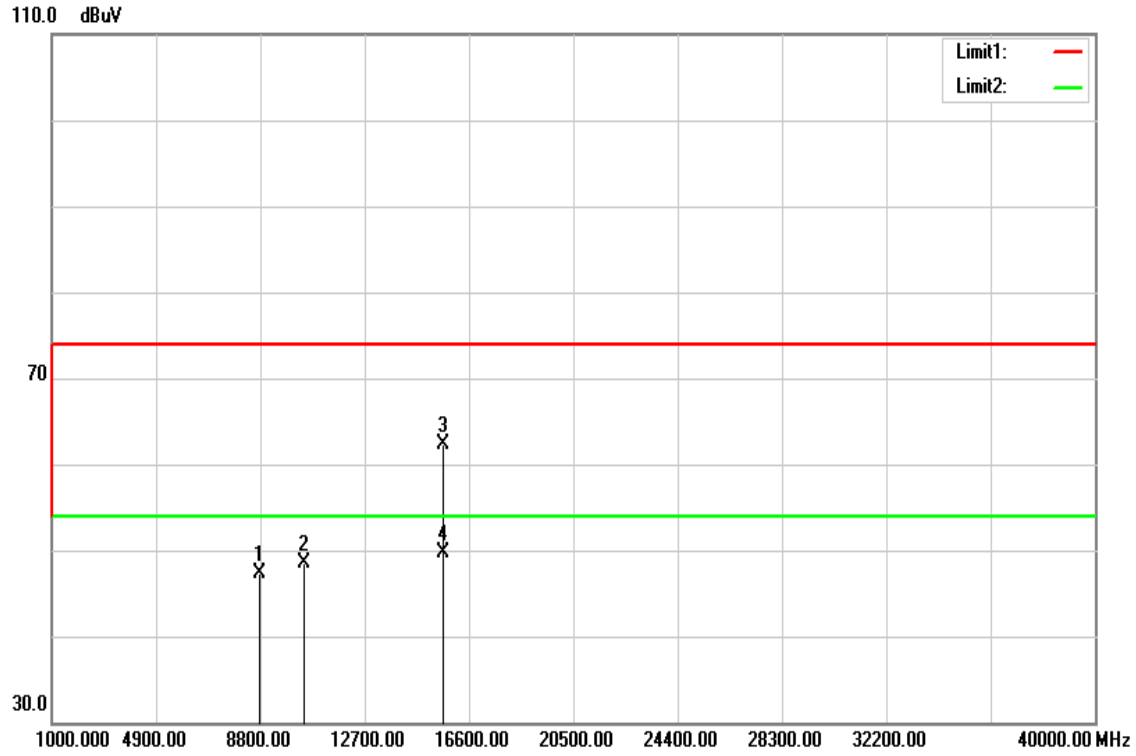

Polarity: Horizontal

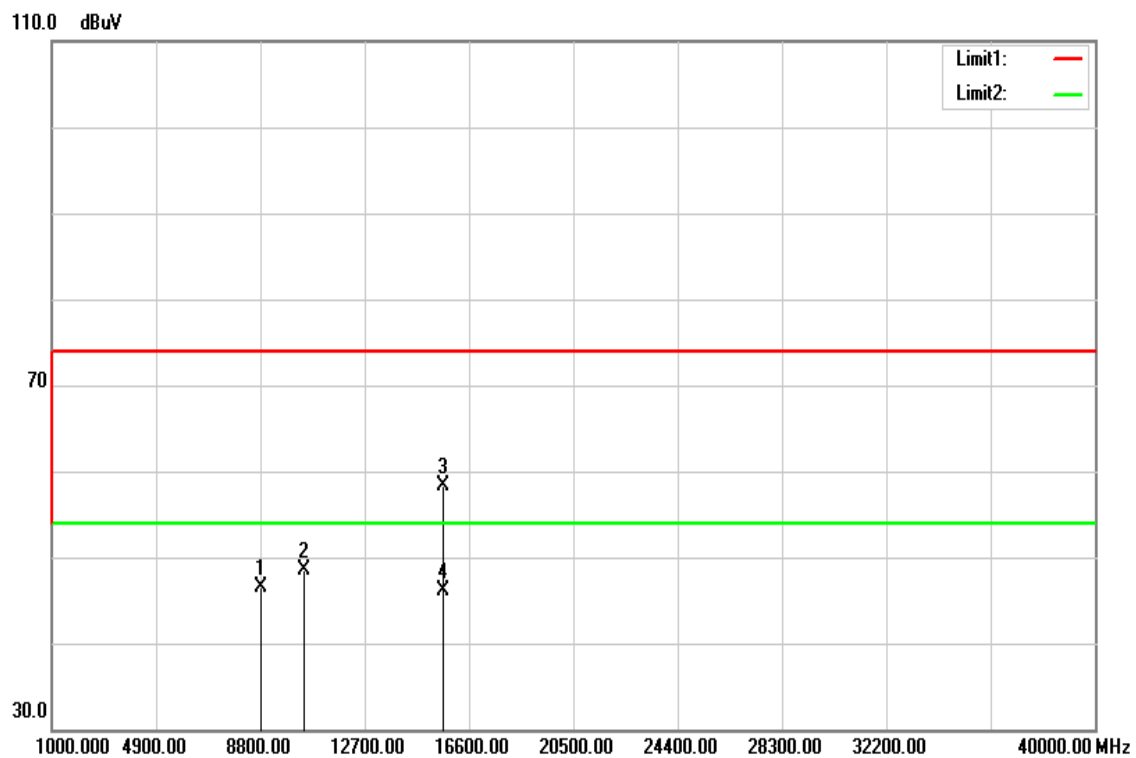

Operation Mode: Tx / IEEE 802.11n HT 20 MHz mode / CH Mid **Test Date:** April 13, 2016
Temperature: 27°C **Tested by:** Jason Lu
Humidity: 53% RH **Polarity:** Ver. / Hor.

Frequency (MHz)	Reading (dBuV)	Correction (dB/m)	Result (dBuV/m)	Limit (dBuV/m)	Margin (dB)	Remark	Ant.Pol. (H/V)
8759.000	33.44	13.76	47.20	74.00	-26.80	peak	V
10440.000	31.66	16.89	48.55	74.00	-25.45	peak	V
15660.000	43.17	19.14	62.31	74.00	-11.69	peak	V
15660.000	30.52	19.14	49.66	54.00	-4.34	AVG	V
N/A							
8824.000	32.78	13.79	46.57	74.00	-27.43	peak	H
10440.000	31.61	16.89	48.50	74.00	-25.50	peak	H
15660.000	39.22	19.14	58.36	74.00	-15.64	peak	H
15660.000	26.97	19.14	46.11	54.00	-7.89	AVG	H
N/A							

Remark:

1. Measuring frequencies from 1 GHz to the 10th harmonic of highest fundamental frequency.
2. Radiated emissions measured in frequency above 1000MHz were made with an instrument using peak/average detector mode.
3. Average test would be performed if the peak result were greater than the average limit.
4. Data of measurement within this frequency range shown " --- " in the table above means the reading of emissions are attenuated more than 20dB below the permissible limits or the field strength is too small to be measured.
5. Measurements above show only up to 6 maximum emissions noted, or would be lesser, with " N/A " remark, if no specific emissions from the EUT are recorded (ie: margin>20dB from the applicable limit) and considered that's already beyond the background noise floor.
6. Margin (dB) = Remark result (dBuV/m) – Average limit (dBuV/m).

Tx / IEEE 802.11n HT 20 MHz mode / CH High

Polarity: Vertical

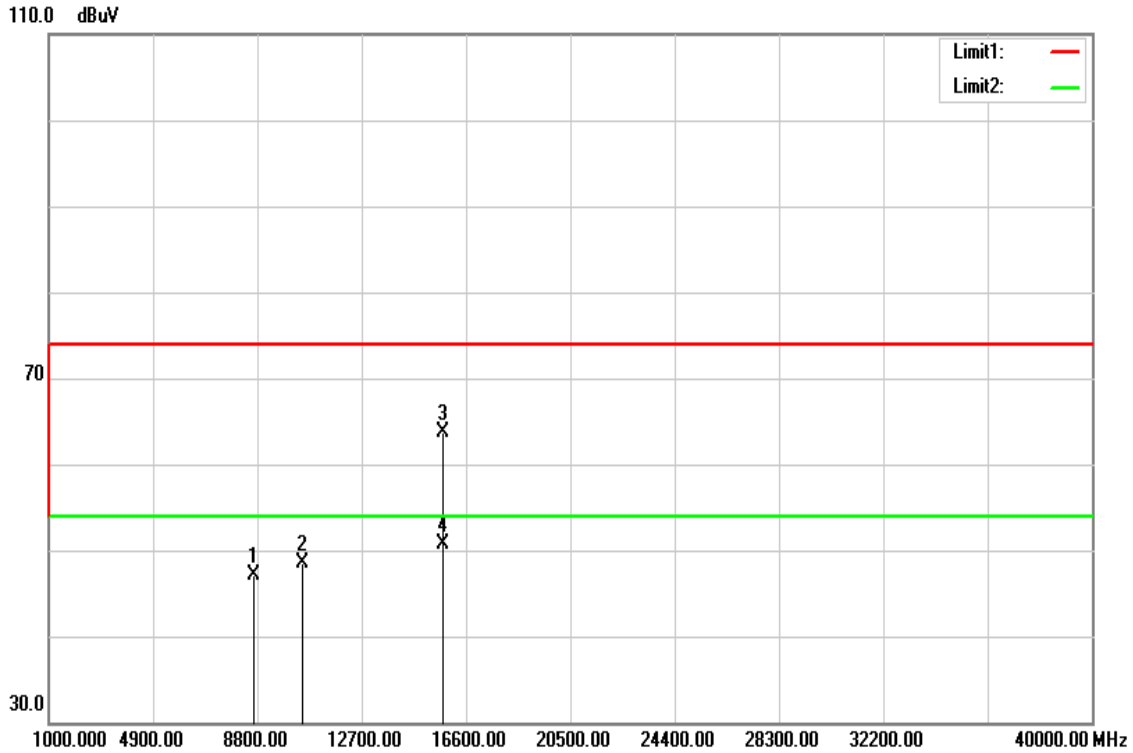

Polarity: Horizontal

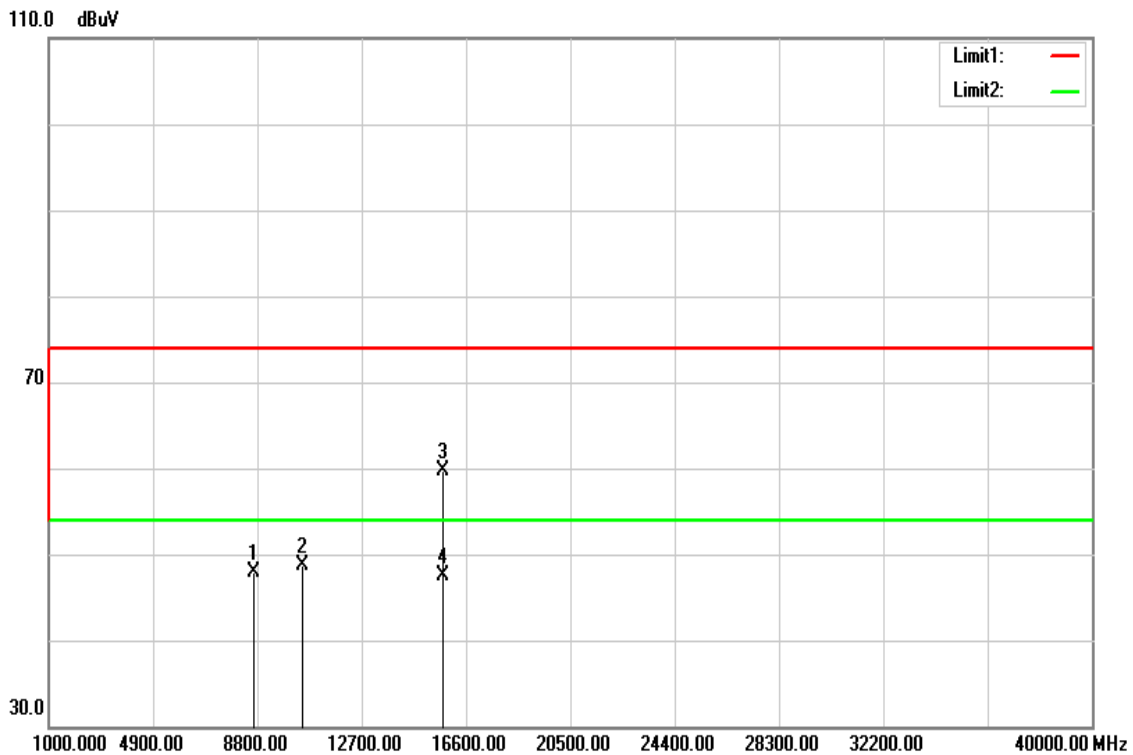

Operation Mode: Tx / IEEE 802.11n HT 20 MHz mode / CH High **Test Date:** April 13, 2016
Temperature: 27°C **Tested by:** Jason Lu
Humidity: 53% RH **Polarity:** Ver. / Hor.

Frequency (MHz)	Reading (dBuV)	Correction (dB/m)	Result (dBuV/m)	Limit (dBuV/m)	Margin (dB)	Remark	Ant.Pol. (H/V)
8688.000	33.34	13.73	47.07	74.00	-26.93	peak	V
10480.000	31.49	17.07	48.56	74.00	-25.44	peak	V
15720.000	44.46	19.19	63.65	74.00	-10.35	peak	V
15720.000	31.54	19.19	50.73	54.00	-3.27	AVG	V
N/A							
8654.000	34.28	13.71	47.99	74.00	-26.01	peak	H
10480.000	31.60	17.07	48.67	74.00	-25.33	peak	H
15720.000	40.45	19.19	59.64	74.00	-14.36	peak	H
15720.000	28.26	19.19	47.45	54.00	-6.55	AVG	H
N/A							

Remark:

1. Measuring frequencies from 1 GHz to the 10th harmonic of highest fundamental frequency.
2. Radiated emissions measured in frequency above 1000MHz were made with an instrument using peak/average detector mode.
3. Average test would be performed if the peak result were greater than the average limit.
4. Data of measurement within this frequency range shown “ --- ” in the table above means the reading of emissions are attenuated more than 20dB below the permissible limits or the field strength is too small to be measured.
5. Measurements above show only up to 6 maximum emissions noted, or would be lesser, with “ N/A ” remark, if no specific emissions from the EUT are recorded (ie: margin>20dB from the applicable limit) and considered that's already beyond the background noise floor.
6. Margin (dB) = Remark result (dBuV/m) – Average limit (dBuV/m).

Tx / IEEE 802.11n HT 40 MHz mode / CH Low

Polarity: Vertical

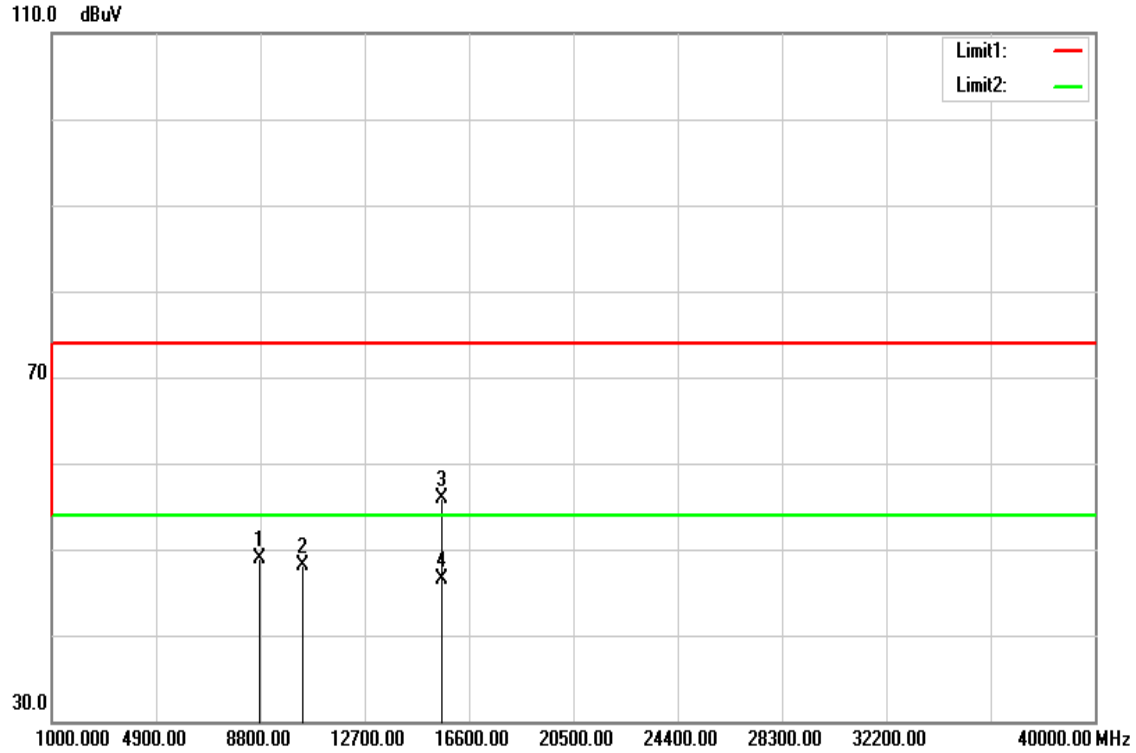

Polarity: Horizontal

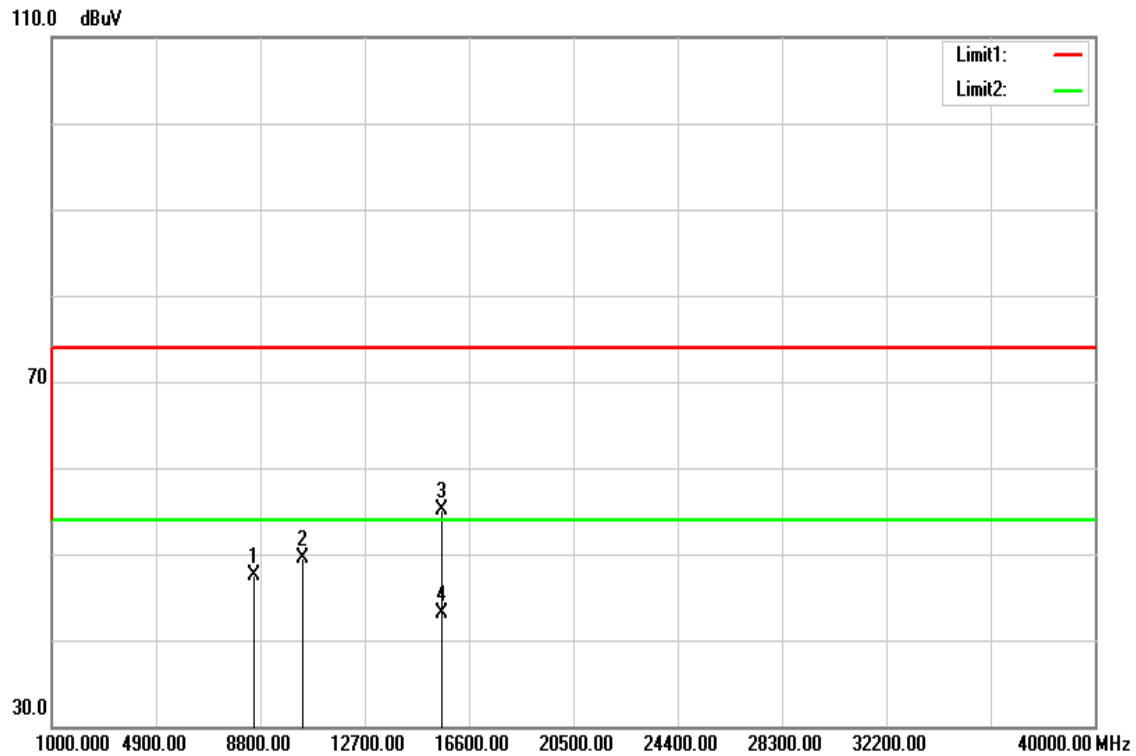

Operation Mode: Tx / IEEE 802.11n HT 40 MHz mode / CH Low
Temperature: 27°C
Humidity: 53% RH

Test Date: April 14, 2016
Tested by: Jason Lu
Polarity: Ver. / Hor.

Frequency (MHz)	Reading (dBuV)	Correction (dB/m)	Result (dBuV/m)	Limit (dBuV/m)	Margin (dB)	Remark	Ant.Pol. (H/V)
8751.000	35.19	13.76	48.95	74.00	-25.05	peak	V
10380.000	31.57	16.62	48.19	74.00	-25.81	peak	V
15570.000	36.83	19.07	55.90	74.00	-18.10	peak	V
15570.000	27.53	19.07	46.60	54.00	-7.40	AVG	V
N/A							
8541.000	33.88	13.66	47.54	74.00	-26.46	peak	H
10380.000	32.83	16.62	49.45	74.00	-24.55	peak	H
15570.000	35.99	19.07	55.06	74.00	-18.94	peak	H
15570.000	23.95	19.07	43.02	54.00	-10.98	AVG	H
N/A							

Remark:

1. Measuring frequencies from 1 GHz to the 10th harmonic of highest fundamental frequency.
2. Radiated emissions measured in frequency above 1000MHz were made with an instrument using peak/average detector mode.
3. Average test would be performed if the peak result were greater than the average limit.
4. Data of measurement within this frequency range shown " --- " in the table above means the reading of emissions are attenuated more than 20dB below the permissible limits or the field strength is too small to be measured.
5. Measurements above show only up to 6 maximum emissions noted, or would be lesser, with " N/A " remark, if no specific emissions from the EUT are recorded (ie: margin>20dB from the applicable limit) and considered that's already beyond the background noise floor.
6. Margin (dB) = Remark result (dBuV/m) – Average limit (dBuV/m).

Tx / IEEE 802.11n HT 40 MHz mode / CH High

Polarity: Vertical

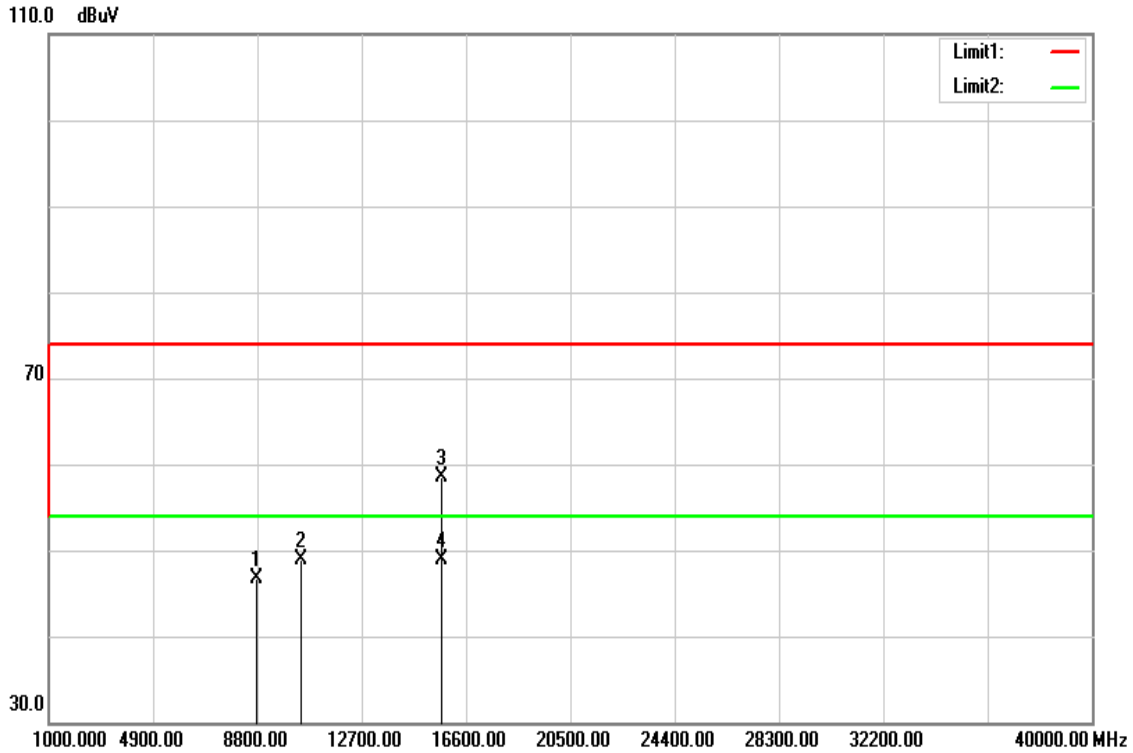

Polarity: Horizontal

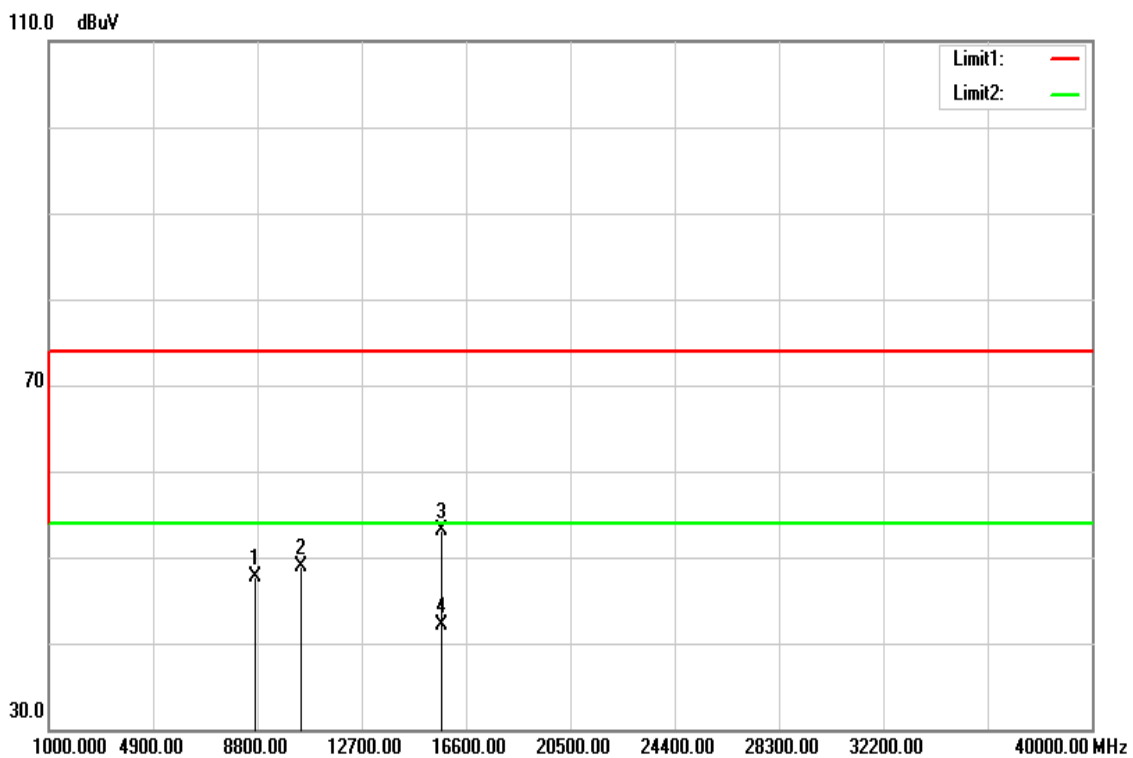

Operation Mode: Tx / IEEE 802.11n HT 40 MHz mode / CH High **Test Date:** April 14, 2016
Temperature: 27°C **Tested by:** Jason Lu
Humidity: 53% RH **Polarity:** Ver. / Hor.

Frequency (MHz)	Reading (dBuV)	Correction (dB/m)	Result (dBuV/m)	Limit (dBuV/m)	Margin (dB)	Remark	Ant.Pol. (H/V)
8754.000	33.04	13.76	46.80	74.00	-27.20	peak	V
10460.000	31.98	16.98	48.96	74.00	-25.04	peak	V
15690.000	39.27	19.17	58.44	74.00	-15.56	peak	V
15690.000	29.83	19.17	49.00	54.00	-5.00	AVG	V
N/A							
8699.000	33.90	13.73	47.63	74.00	-26.37	peak	H
10460.000	31.86	16.98	48.84	74.00	-25.16	peak	H
15690.000	33.95	19.17	53.12	74.00	-20.88	peak	H
15690.000	22.96	19.17	42.13	54.00	-11.87	AVG	H
N/A							

Remark:

1. Measuring frequencies from 1 GHz to the 10th harmonic of highest fundamental frequency.
2. Radiated emissions measured in frequency above 1000MHz were made with an instrument using peak/average detector mode.
3. Average test would be performed if the peak result were greater than the average limit.
4. Data of measurement within this frequency range shown " --- " in the table above means the reading of emissions are attenuated more than 20dB below the permissible limits or the field strength is too small to be measured.
5. Measurements above show only up to 6 maximum emissions noted, or would be lesser, with " N/A " remark, if no specific emissions from the EUT are recorded (ie: margin>20dB from the applicable limit) and considered that's already beyond the background noise floor.
6. Margin (dB) = Remark result (dBuV/m) – Average limit (dBuV/m).

U-NII-2A

Tx / IEEE 802.11a mode / CH Low

Polarity: Vertical

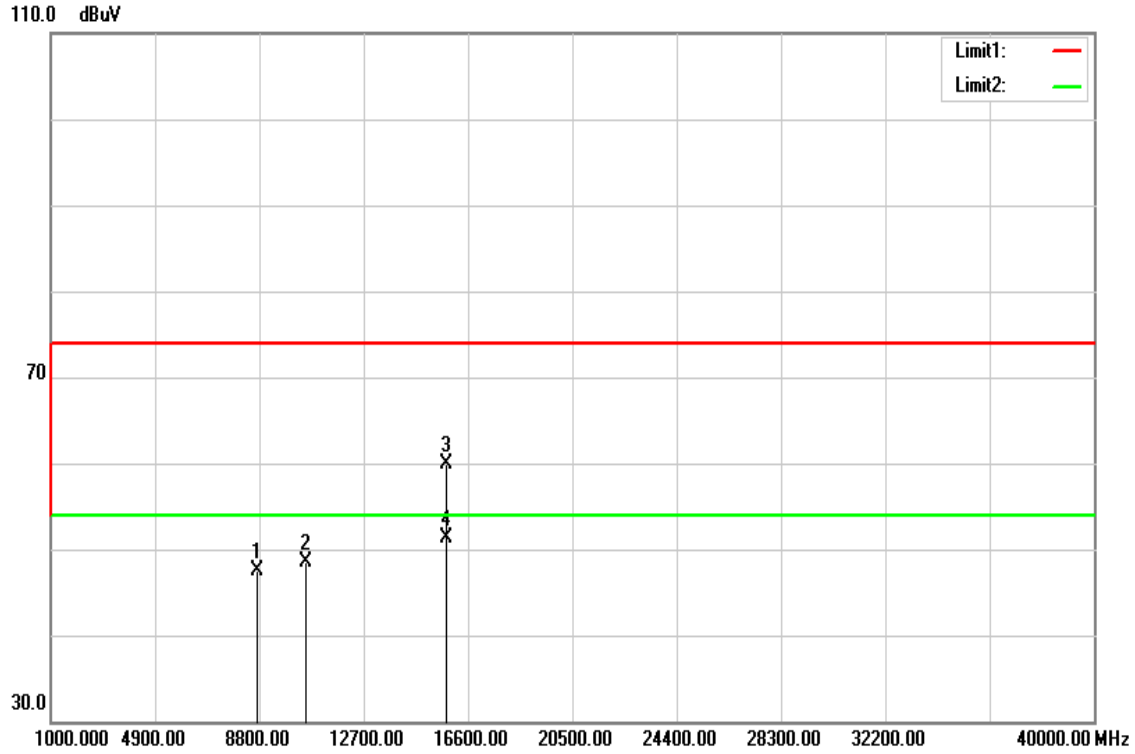

Polarity: Horizontal

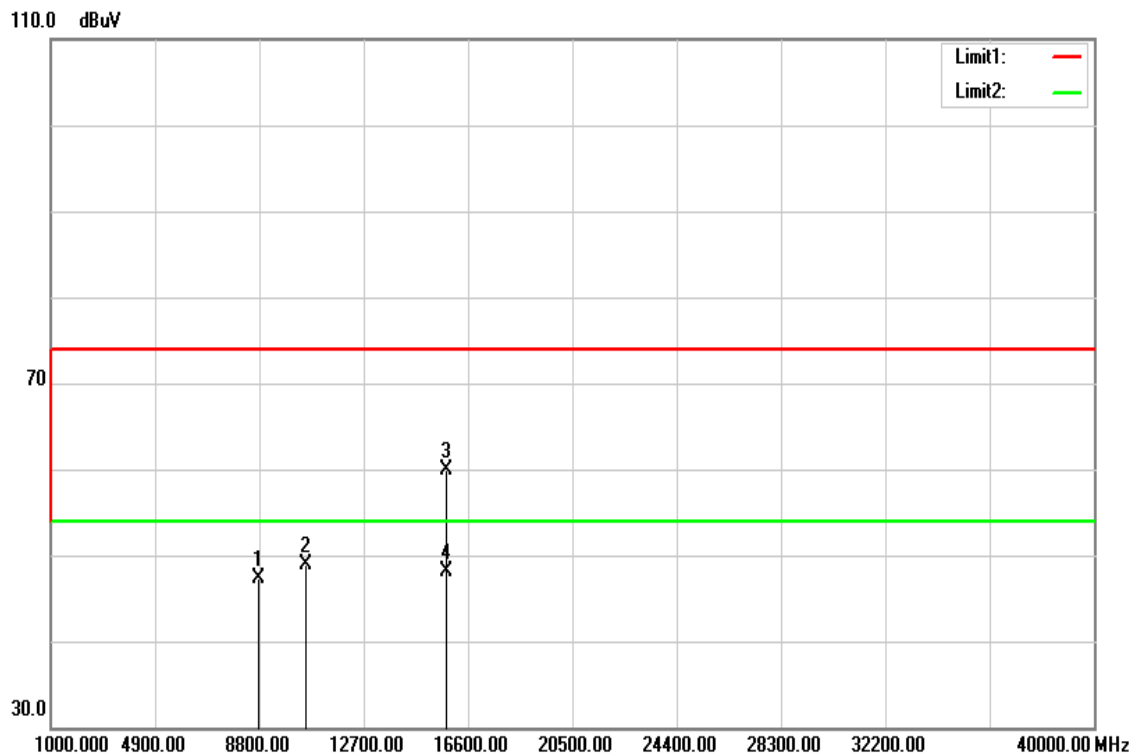

Operation Mode: Tx / IEEE 802.11a mode / CH Low

Test Date: April 13, 2016

Temperature: 27°C

Tested by: Jason Lu

Humidity: 53% RH

Polarity: Ver. / Hor.

Frequency (MHz)	Reading (dBuV)	Correction (dB/m)	Result (dBuV/m)	Limit (dBuV/m)	Margin (dB)	Remark	Ant.Pol. (H/V)
8709.000	33.83	13.74	47.57	74.00	-26.43	peak	V
10520.000	31.37	17.14	48.51	74.00	-25.49	peak	V
15780.000	40.74	19.25	59.99	74.00	-14.01	peak	V
15780.000	31.98	19.25	51.23	54.00	-2.77	AVG	V
N/A							
8754.000	33.51	13.76	47.27	74.00	-26.73	peak	H
10520.000	31.71	17.14	48.85	74.00	-25.15	peak	H
15780.000	40.68	19.25	59.93	74.00	-14.07	peak	H
15780.000	28.94	19.25	48.19	54.00	-5.81	AVG	H
N/A							

Remark:

1. Measuring frequencies from 1 GHz to the 10th harmonic of highest fundamental frequency.
2. Radiated emissions measured in frequency above 1000MHz were made with an instrument using peak/average detector mode.
3. Average test would be performed if the peak result were greater than the average limit.
4. Data of measurement within this frequency range shown " --- " in the table above means the reading of emissions are attenuated more than 20dB below the permissible limits or the field strength is too small to be measured.
5. Measurements above show only up to 6 maximum emissions noted, or would be lesser, with " N/A " remark, if no specific emissions from the EUT are recorded (ie: margin>20dB from the applicable limit) and considered that's already beyond the background noise floor.
6. Margin (dB) = Remark result (dBuV/m) – Average limit (dBuV/m).

Tx / IEEE 802.11a mode / CH Mid

Polarity: Vertical

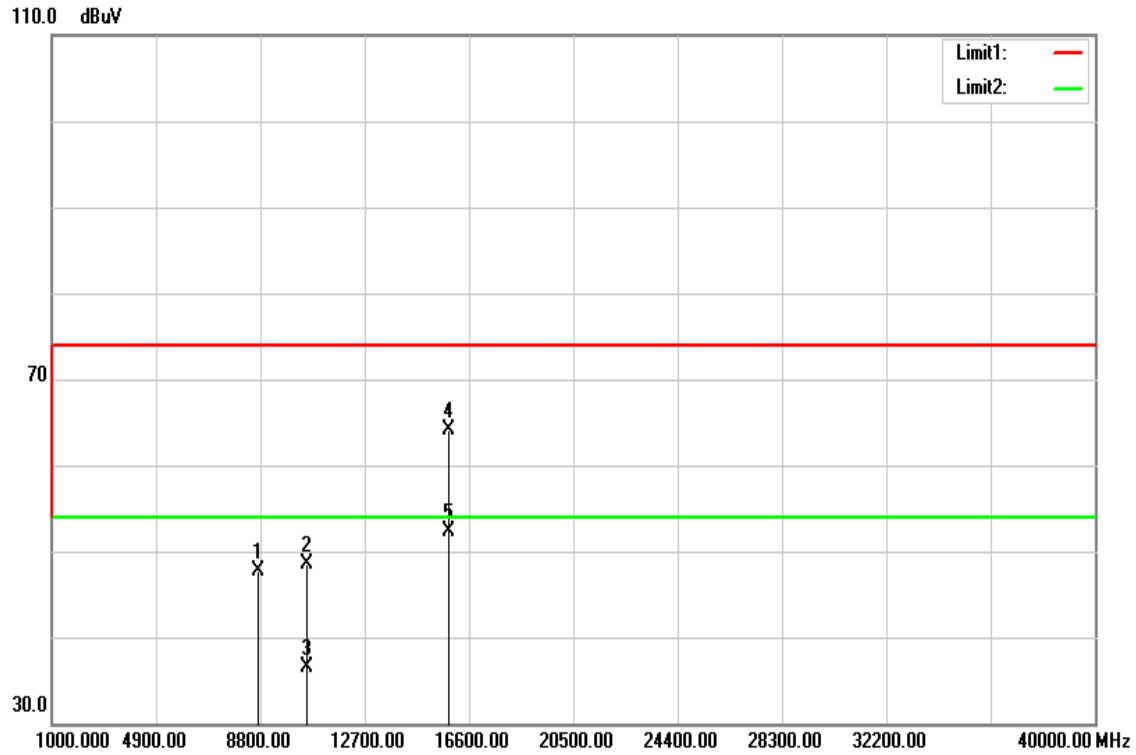

Polarity: Horizontal

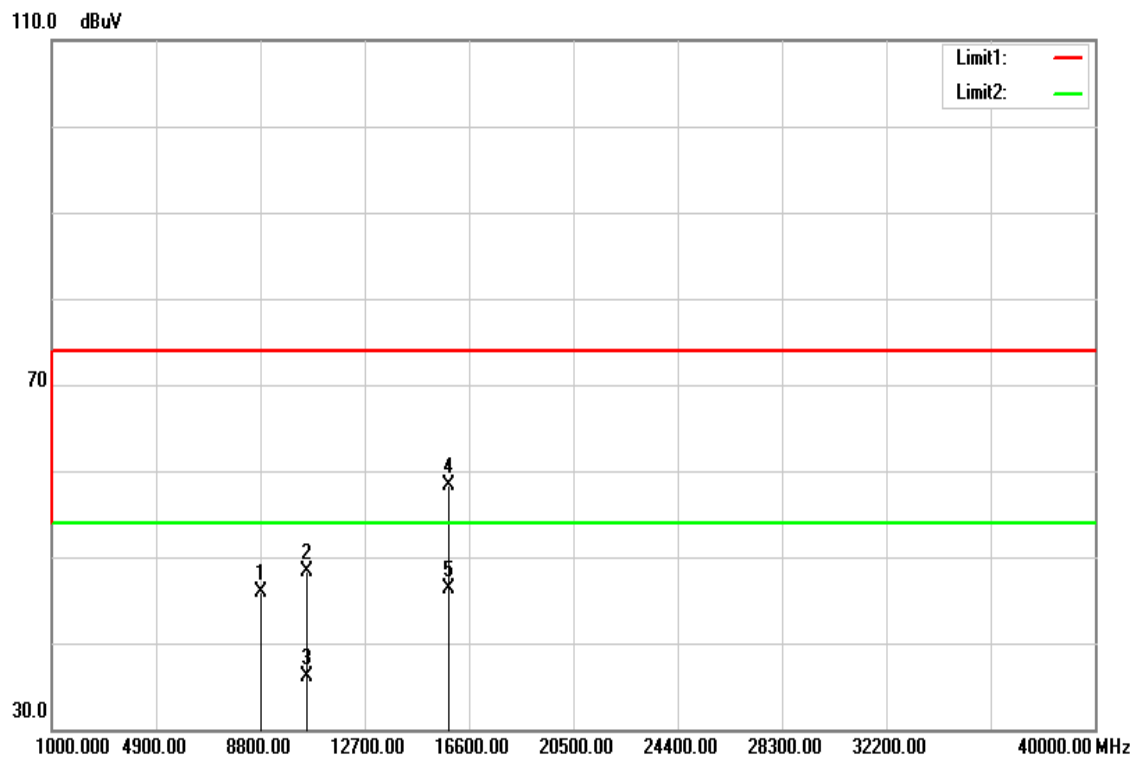

Operation Mode: Tx / IEEE 802.11a mode / CH Mid

Test Date: April 13, 2016

Temperature: 27°C

Tested by: Jason Lu

Humidity: 53% RH

Polarity: Ver. / Hor.

Frequency (MHz)	Reading (dBuV)	Correction (dB/m)	Result (dBuV/m)	Limit (dBuV/m)	Margin (dB)	Remark	Ant.Pol. (H/V)
8729.000	33.95	13.75	47.70	74.00	-26.30	peak	V
10560.000	31.37	17.11	48.48	74.00	-25.52	peak	V
10560.000	19.40	17.11	36.51	54.00	-17.49	AVG	V
15840.000	44.75	19.30	64.05	74.00	-9.95	peak	V
15840.000	33.01	19.30	52.31	54.00	-1.69	AVG	V
N/A							
8821.000	32.05	13.79	45.84	74.00	-28.16	peak	H
10560.000	31.26	17.11	48.37	74.00	-25.63	peak	H
10560.000	19.04	17.11	36.15	54.00	-17.85	AVG	H
15840.000	38.97	19.30	58.27	74.00	-15.73	peak	H
15840.000	26.92	19.30	46.22	54.00	-7.78	AVG	H
N/A							

Remark:

1. Measuring frequencies from 1 GHz to the 10th harmonic of highest fundamental frequency.
2. Radiated emissions measured in frequency above 1000MHz were made with an instrument using peak/average detector mode.
3. Average test would be performed if the peak result were greater than the average limit.
4. Data of measurement within this frequency range shown " --- " in the table above means the reading of emissions are attenuated more than 20dB below the permissible limits or the field strength is too small to be measured.
5. Measurements above show only up to 6 maximum emissions noted, or would be lesser, with " N/A " remark, if no specific emissions from the EUT are recorded (ie: margin>20dB from the applicable limit) and considered that's already beyond the background noise floor.
6. Margin (dB) = Remark result (dBuV/m) – Average limit (dBuV/m).

Tx / IEEE 802.11a mode / CH High

Polarity: Vertical

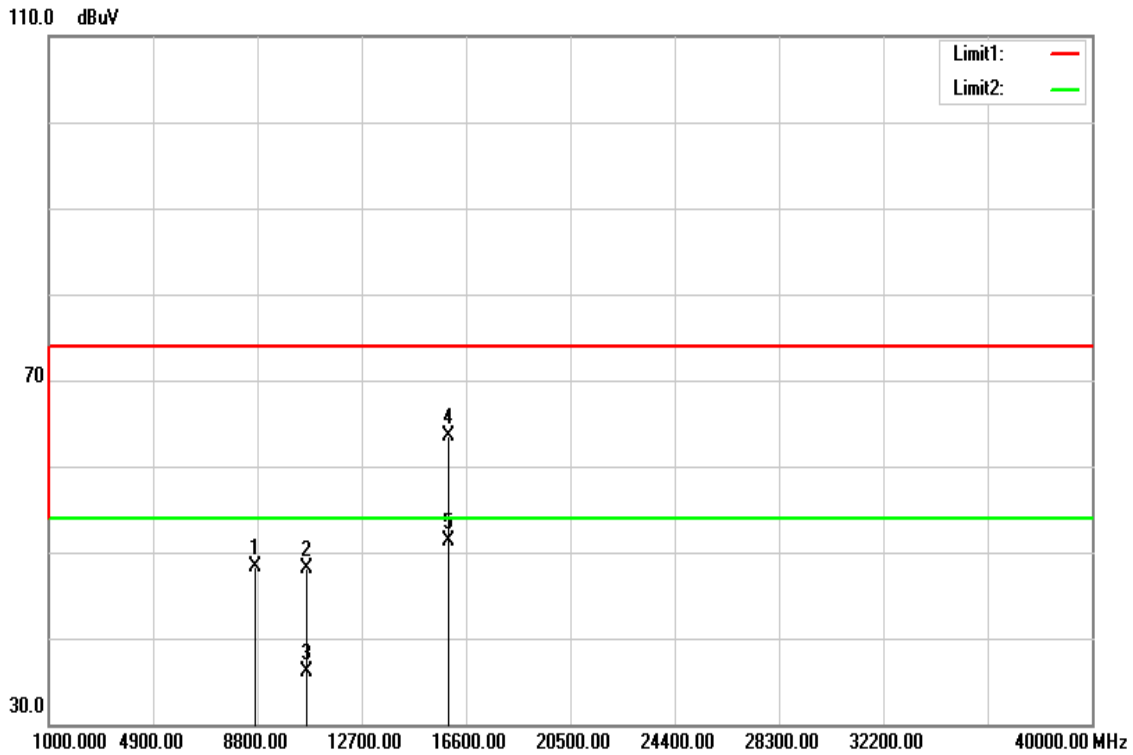

Polarity: Horizontal

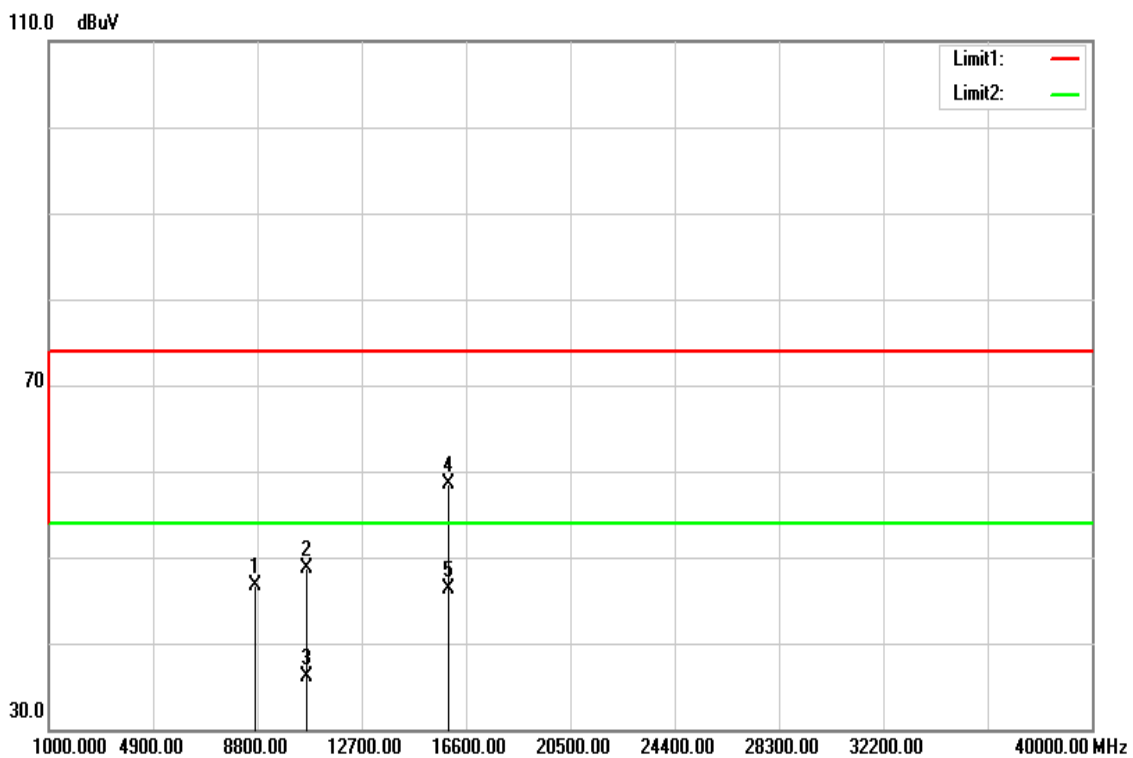

Operation Mode: Tx / IEEE 802.11a mode / CH High

Test Date: April 13, 2016

Temperature: 27°C

Tested by: Jason Lu

Humidity: 53% RH

Polarity: Ver. / Hor.

Frequency (MHz)	Reading (dBuV)	Correction (dB/m)	Result (dBuV/m)	Limit (dBuV/m)	Margin (dB)	Remark	Ant.Pol. (H/V)
8706.000	34.67	13.73	48.40	74.00	-25.60	peak	V
10640.000	31.02	17.04	48.06	74.00	-25.94	peak	V
10640.000	19.11	17.04	36.15	54.00	-17.85	AVG	V
15960.000	44.11	19.40	63.51	74.00	-10.49	peak	V
15960.000	31.92	19.40	51.32	54.00	-2.68	AVG	V
N/A							
8729.000	32.99	13.75	46.74	74.00	-27.26	peak	H
10640.000	31.73	17.04	48.77	74.00	-25.23	peak	H
10640.000	19.15	17.04	36.19	54.00	-17.81	AVG	H
15960.000	39.13	19.40	58.53	74.00	-15.47	peak	H
15960.000	26.98	19.40	46.38	54.00	-7.62	AVG	H
N/A							

Remark:

1. *Measuring frequencies from 1 GHz to the 10th harmonic of highest fundamental frequency.*
2. *Radiated emissions measured in frequency above 1000MHz were made with an instrument using peak/average detector mode.*
3. *Average test would be performed if the peak result were greater than the average limit.*
4. *Data of measurement within this frequency range shown " --- " in the table above means the reading of emissions are attenuated more than 20dB below the permissible limits or the field strength is too small to be measured.*
5. *Measurements above show only up to 6 maximum emissions noted, or would be lesser, with " N/A " remark, if no specific emissions from the EUT are recorded (ie: margin>20dB from the applicable limit) and considered that's already beyond the background noise floor.*
6. *Margin (dB) = Remark result (dBuV/m) – Average limit (dBuV/m).*

Tx / IEEE 802.11n HT 20 MHz mode / CH Low

Polarity: Vertical

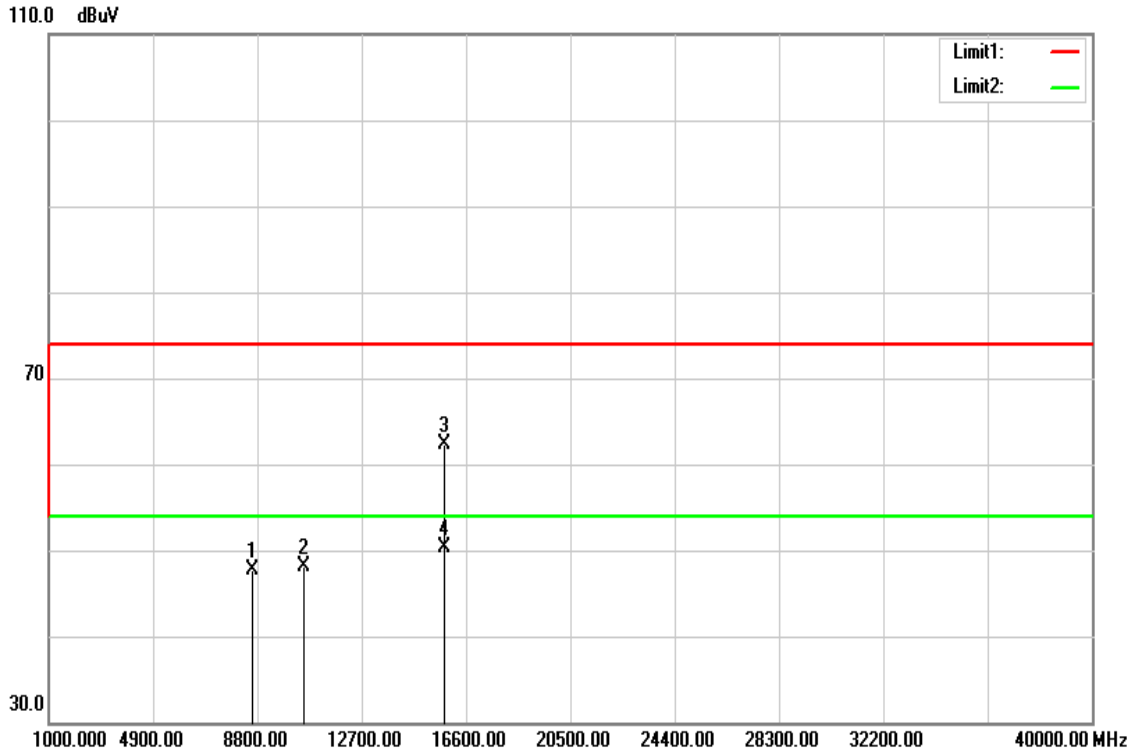

Polarity: Horizontal

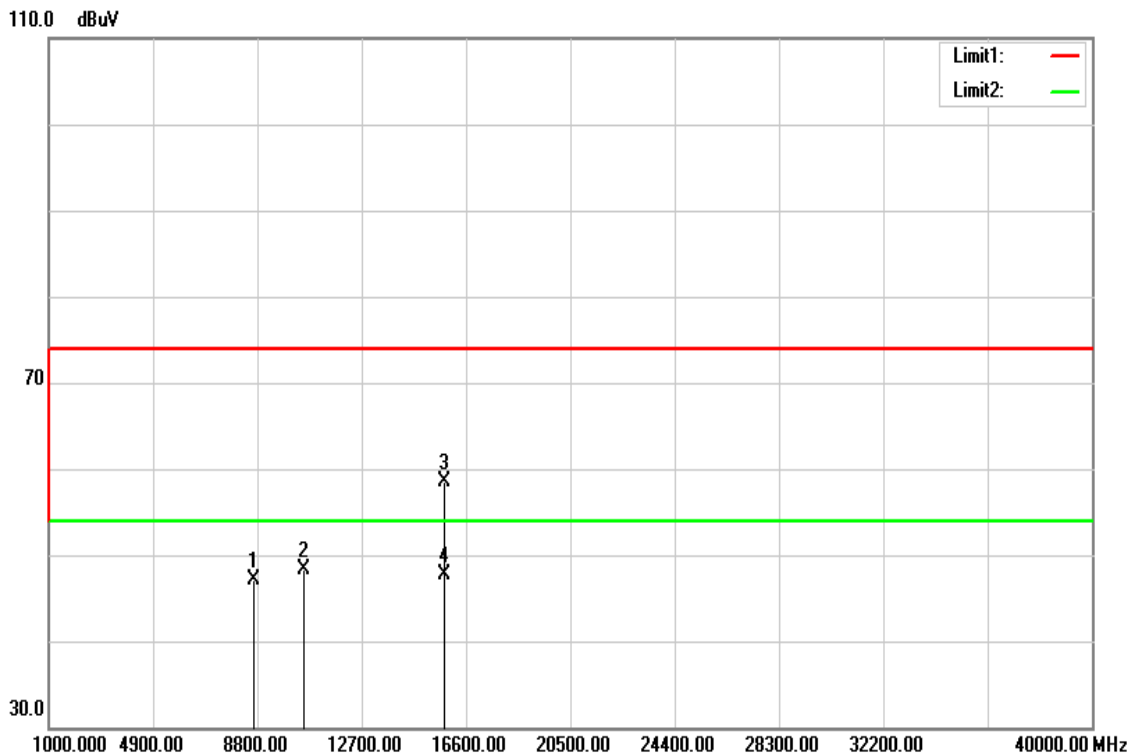

Operation Mode: Tx / IEEE 802.11n HT 20 MHz mode / CH Low **Test Date:** April 13, 2016
Temperature: 27°C **Tested by:** Jason Lu
Humidity: 53% RH **Polarity:** Ver. / Hor.

Frequency (MHz)	Reading (dBuV)	Correction (dB/m)	Result (dBuV/m)	Limit (dBuV/m)	Margin (dB)	Remark	Ant.Pol. (H/V)
8643.000	34.06	13.71	47.77	74.00	-26.23	peak	V
10520.000	30.88	17.14	48.02	74.00	-25.98	peak	V
15780.000	43.12	19.25	62.37	74.00	-11.63	peak	V
15780.000	31.00	19.25	50.25	54.00	-3.75	AVG	V
N/A							
8679.000	33.40	13.72	47.12	74.00	-26.88	peak	H
10520.000	31.22	17.14	48.36	74.00	-25.64	peak	H
15780.000	39.16	19.25	58.41	74.00	-15.59	peak	H
15780.000	28.50	19.25	47.75	54.00	-6.25	AVG	H
N/A							

Remark:

1. Measuring frequencies from 1 GHz to the 10th harmonic of highest fundamental frequency.
2. Radiated emissions measured in frequency above 1000MHz were made with an instrument using peak/average detector mode.
3. Average test would be performed if the peak result were greater than the average limit.
4. Data of measurement within this frequency range shown " --- " in the table above means the reading of emissions are attenuated more than 20dB below the permissible limits or the field strength is too small to be measured.
5. Measurements above show only up to 6 maximum emissions noted, or would be lesser, with " N/A " remark, if no specific emissions from the EUT are recorded (ie: margin>20dB from the applicable limit) and considered that's already beyond the background noise floor.
6. Margin (dB) = Remark result (dBuV/m) – Average limit (dBuV/m).

Tx / IEEE 802.11n HT 20 MHz mode / CH Mid

Polarity: Vertical

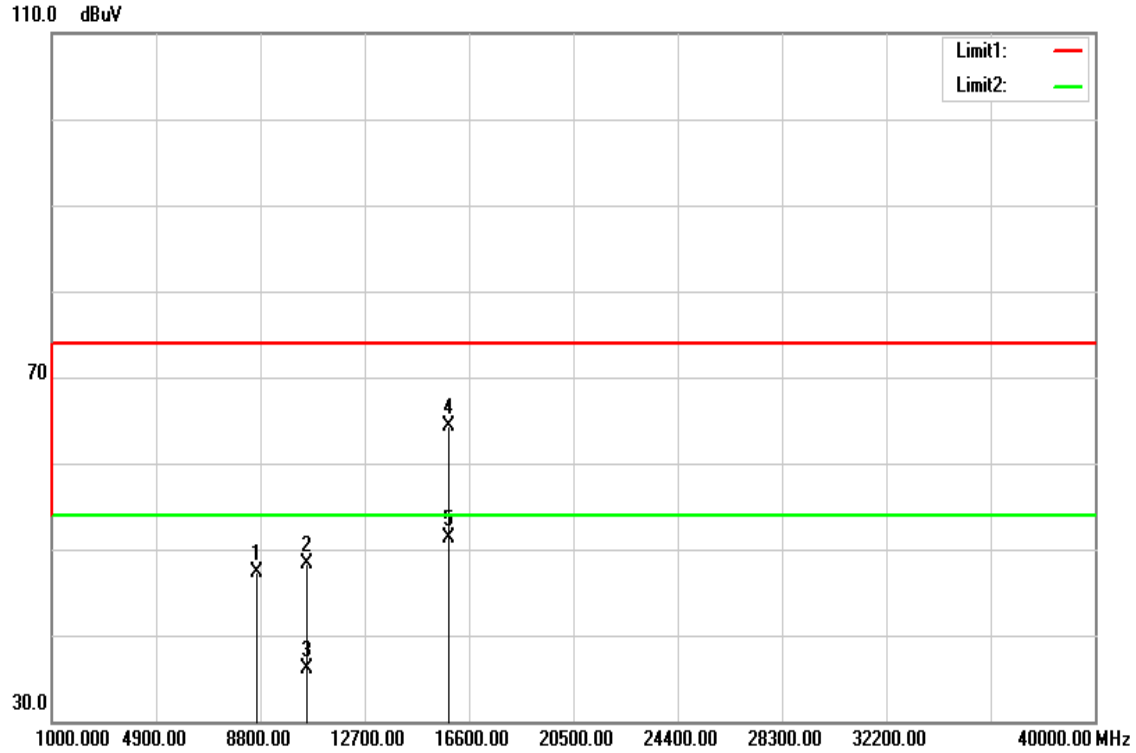

Polarity: Horizontal

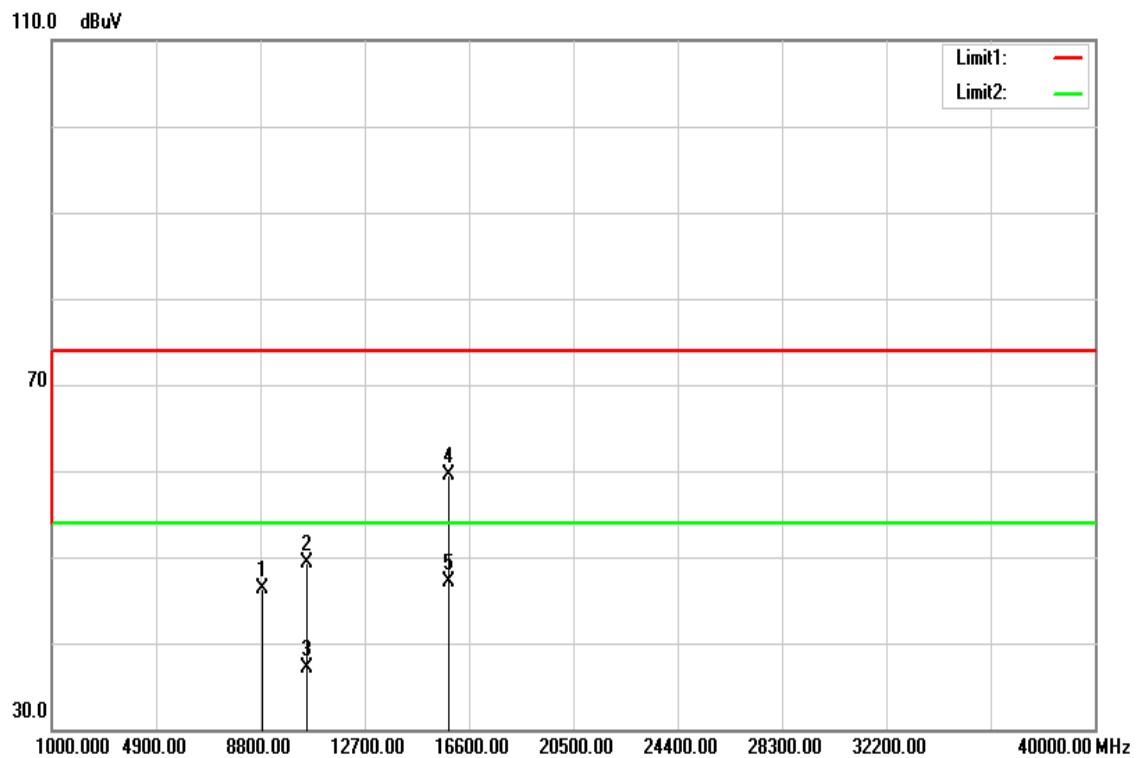

Operation Mode: Tx / IEEE 802.11n HT 20 MHz mode / CH Mid **Test Date:** April 13, 2016
Temperature: 27°C **Tested by:** Jason Lu
Humidity: 53% RH **Polarity:** Ver. / Hor.

Frequency (MHz)	Reading (dBuV)	Correction (dB/m)	Result (dBuV/m)	Limit (dBuV/m)	Margin (dB)	Remark	Ant.Pol. (H/V)
8677.000	33.57	13.72	47.29	74.00	-26.71	peak	V
10560.000	31.26	17.11	48.37	74.00	-25.63	peak	V
10560.000	19.00	17.11	36.11	54.00	-17.89	AVG	V
15840.000	45.00	19.30	64.30	74.00	-9.70	peak	V
15840.000	32.00	19.30	51.30	54.00	-2.70	AVG	V
N/A							
8855.000	32.48	13.80	46.28	74.00	-27.72	peak	H
10560.000	32.11	17.11	49.22	74.00	-24.78	peak	H
10560.000	19.91	17.11	37.02	54.00	-16.98	AVG	H
15840.000	40.22	19.30	59.52	74.00	-14.48	peak	H
15840.000	27.81	19.30	47.11	54.00	-6.89	AVG	H
N/A							

Remark:

1. Measuring frequencies from 1 GHz to the 10th harmonic of highest fundamental frequency.
2. Radiated emissions measured in frequency above 1000MHz were made with an instrument using peak/average detector mode.
3. Average test would be performed if the peak result were greater than the average limit.
4. Data of measurement within this frequency range shown " --- " in the table above means the reading of emissions are attenuated more than 20dB below the permissible limits or the field strength is too small to be measured.
5. Measurements above show only up to 6 maximum emissions noted, or would be lesser, with " N/A " remark, if no specific emissions from the EUT are recorded (ie: margin>20dB from the applicable limit) and considered that's already beyond the background noise floor.
6. Margin (dB) = Remark result (dBuV/m) – Average limit (dBuV/m).

Tx / IEEE 802.11n HT 20 MHz mode / CH High

Polarity: Vertical

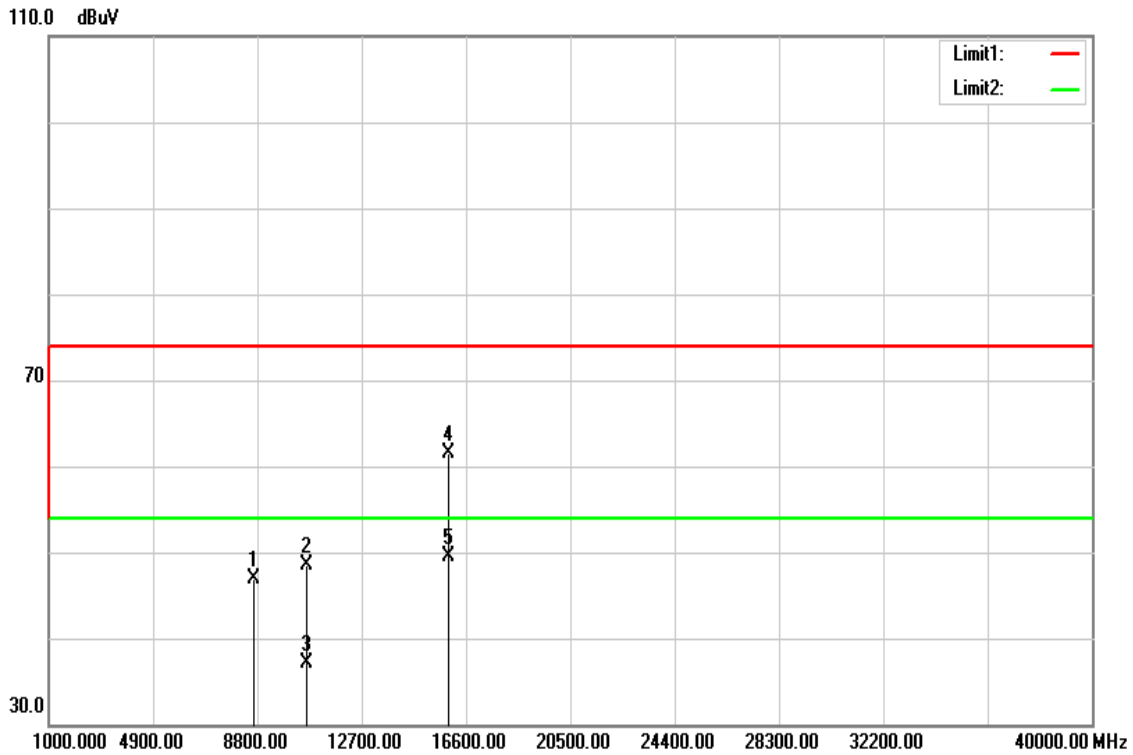

Polarity: Horizontal

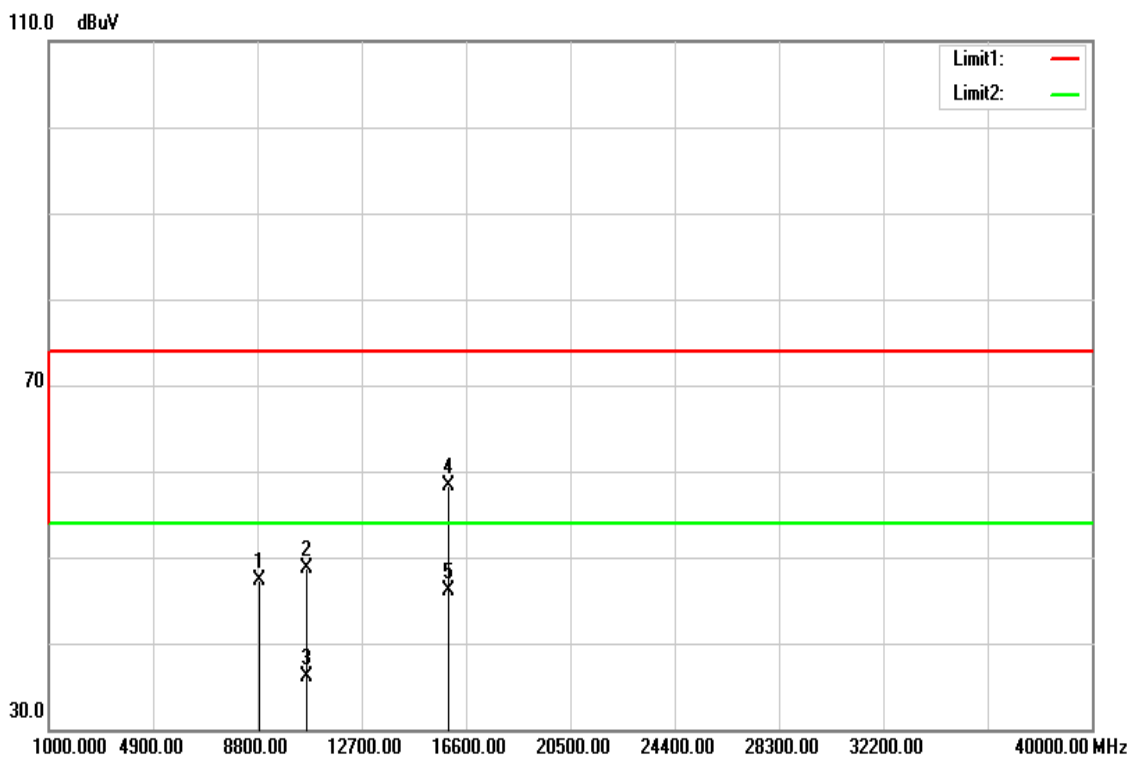

Operation Mode: Tx / IEEE 802.11n HT 20 MHz mode / CH High
Temperature: 27°C
Humidity: 53% RH

Test Date: April 13, 2016
Tested by: Jason Lu
Polarity: Ver. / Hor.

Frequency (MHz)	Reading (dBuV)	Correction (dB/m)	Result (dBuV/m)	Limit (dBuV/m)	Margin (dB)	Remark	Ant.Pol. (H/V)
8667.000	33.22	13.72	46.94	74.00	-27.06	peak	V
10640.000	31.45	17.04	48.49	74.00	-25.51	peak	V
10640.000	20.08	17.04	37.12	54.00	-16.88	AVG	V
15960.000	42.01	19.40	61.41	74.00	-12.59	peak	V
15960.000	30.12	19.40	49.52	54.00	-4.48	AVG	V
N/A							
8852.000	33.55	13.80	47.35	74.00	-26.65	peak	H
10640.000	31.71	17.04	48.75	74.00	-25.25	peak	H
10640.000	18.98	17.04	36.02	54.00	-17.98	AVG	H
15960.000	38.81	19.40	58.21	74.00	-15.79	peak	H
15960.000	26.70	19.40	46.10	54.00	-7.90	AVG	H
N/A							

Remark:

1. Measuring frequencies from 1 GHz to the 10th harmonic of highest fundamental frequency.
2. Radiated emissions measured in frequency above 1000MHz were made with an instrument using peak/average detector mode.
3. Average test would be performed if the peak result were greater than the average limit.
4. Data of measurement within this frequency range shown “ --- ” in the table above means the reading of emissions are attenuated more than 20dB below the permissible limits or the field strength is too small to be measured.
5. Measurements above show only up to 6 maximum emissions noted, or would be lesser, with “ N/A ” remark, if no specific emissions from the EUT are recorded (ie: margin>20dB from the applicable limit) and considered that's already beyond the background noise floor.
6. Margin (dB) = Remark result (dBuV/m) – Average limit (dBuV/m).

Tx / IEEE 802.11n HT 40 MHz mode / CH Low

Polarity: Vertical

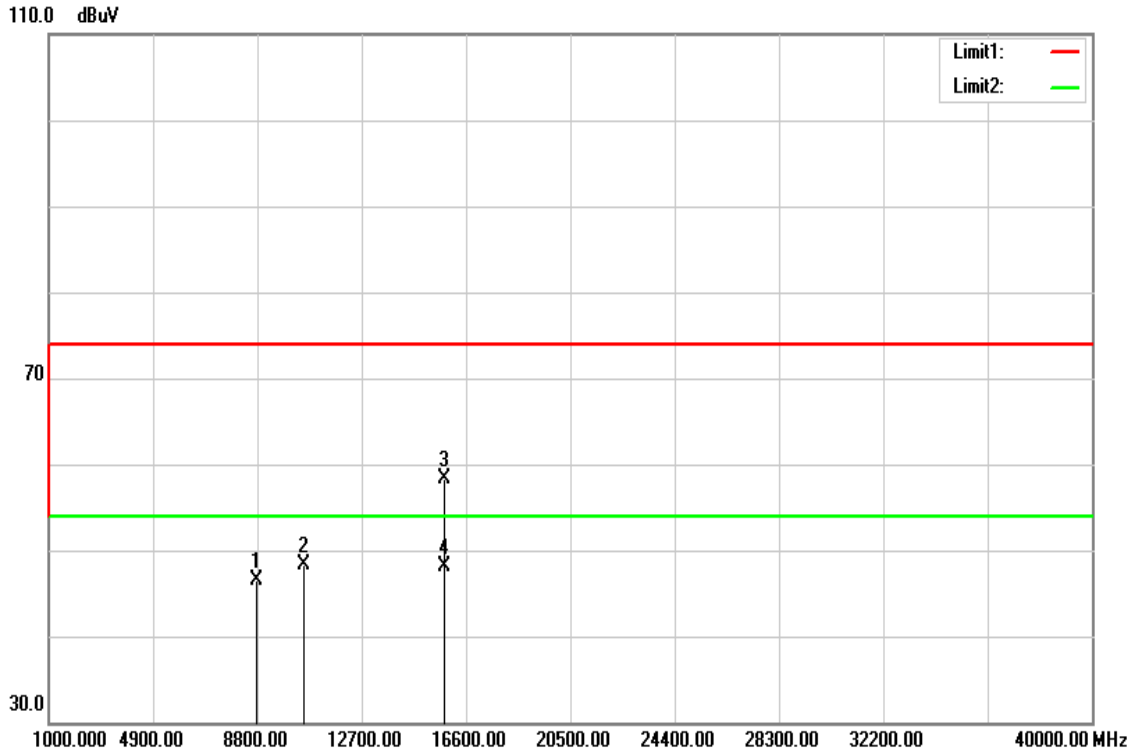

Polarity: Horizontal

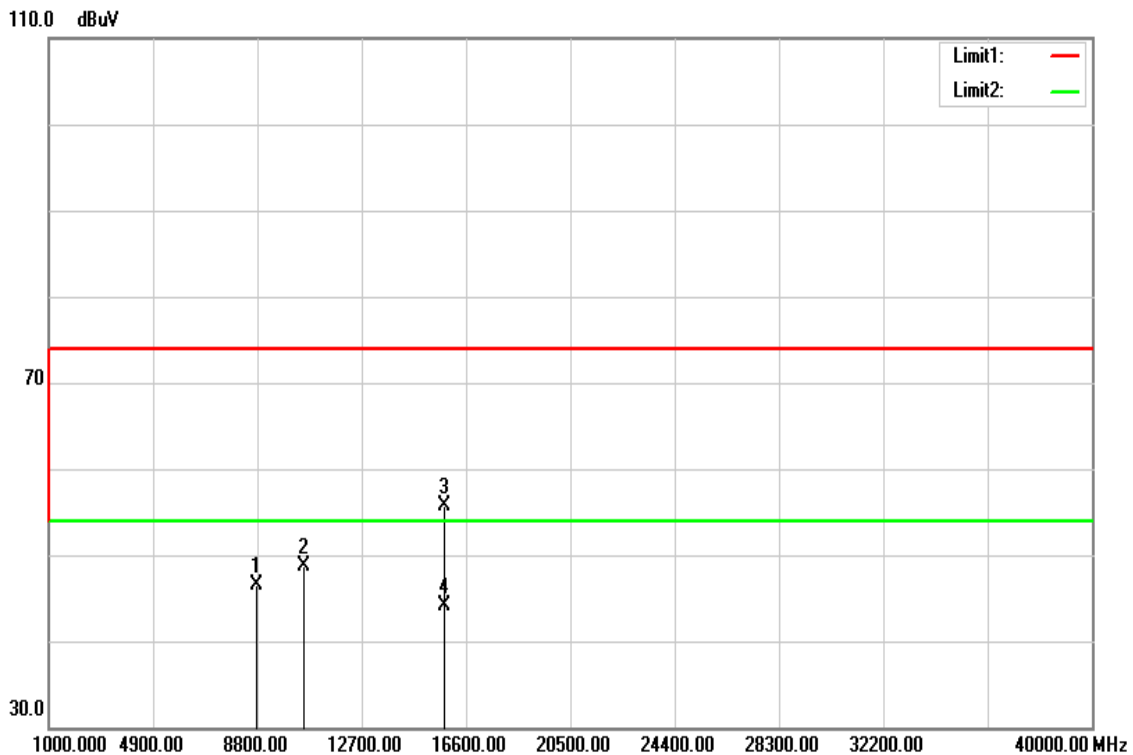

Operation Mode: Tx / IEEE 802.11n HT 40 MHz mode / CH Low **Test Date:** April 14, 2016
Temperature: 27°C **Tested by:** Jason Lu
Humidity: 53% RH **Polarity:** Ver. / Hor.

Frequency (MHz)	Reading (dBuV)	Correction (dB/m)	Result (dBuV/m)	Limit (dBuV/m)	Margin (dB)	Remark	Ant.Pol. (H/V)
8754.000	32.73	13.76	46.49	74.00	-27.51	peak	V
10540.000	31.25	17.13	48.38	74.00	-25.62	peak	V
15810.000	39.04	19.27	58.31	74.00	-15.69	peak	V
15810.000	28.75	19.27	48.02	54.00	-5.98	AVG	V
N/A							
8755.000	32.84	13.76	46.60	74.00	-27.40	peak	H
10540.000	31.63	17.13	48.76	74.00	-25.24	peak	H
15810.000	36.42	19.27	55.69	74.00	-18.31	peak	H
15810.000	24.85	19.27	44.12	54.00	-9.88	AVG	H
N/A							

Remark:

1. Measuring frequencies from 1 GHz to the 10th harmonic of highest fundamental frequency.
2. Radiated emissions measured in frequency above 1000MHz were made with an instrument using peak/average detector mode.
3. Average test would be performed if the peak result were greater than the average limit.
4. Data of measurement within this frequency range shown " --- " in the table above means the reading of emissions are attenuated more than 20dB below the permissible limits or the field strength is too small to be measured.
5. Measurements above show only up to 6 maximum emissions noted, or would be lesser, with " N/A " remark, if no specific emissions from the EUT are recorded (ie: margin>20dB from the applicable limit) and considered that's already beyond the background noise floor.
6. Margin (dB) = Remark result (dBuV/m) – Average limit (dBuV/m).

Tx / IEEE 802.11n HT 40 MHz mode / CH High

Polarity: Vertical

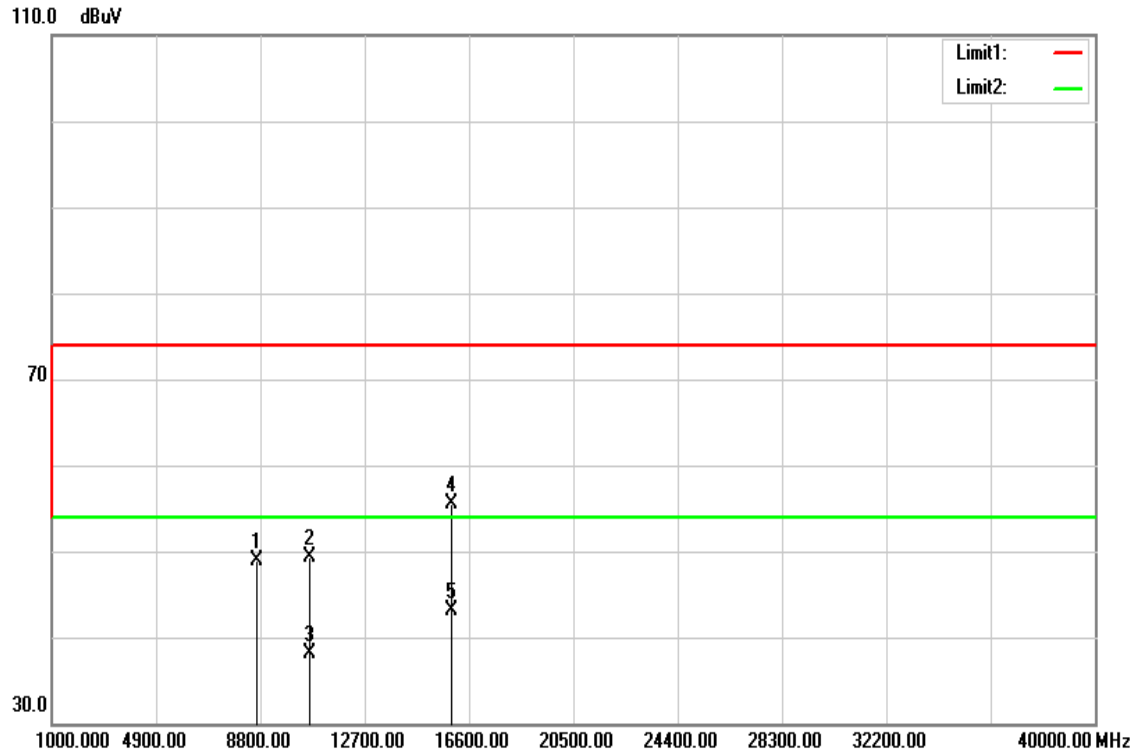

Polarity: Horizontal

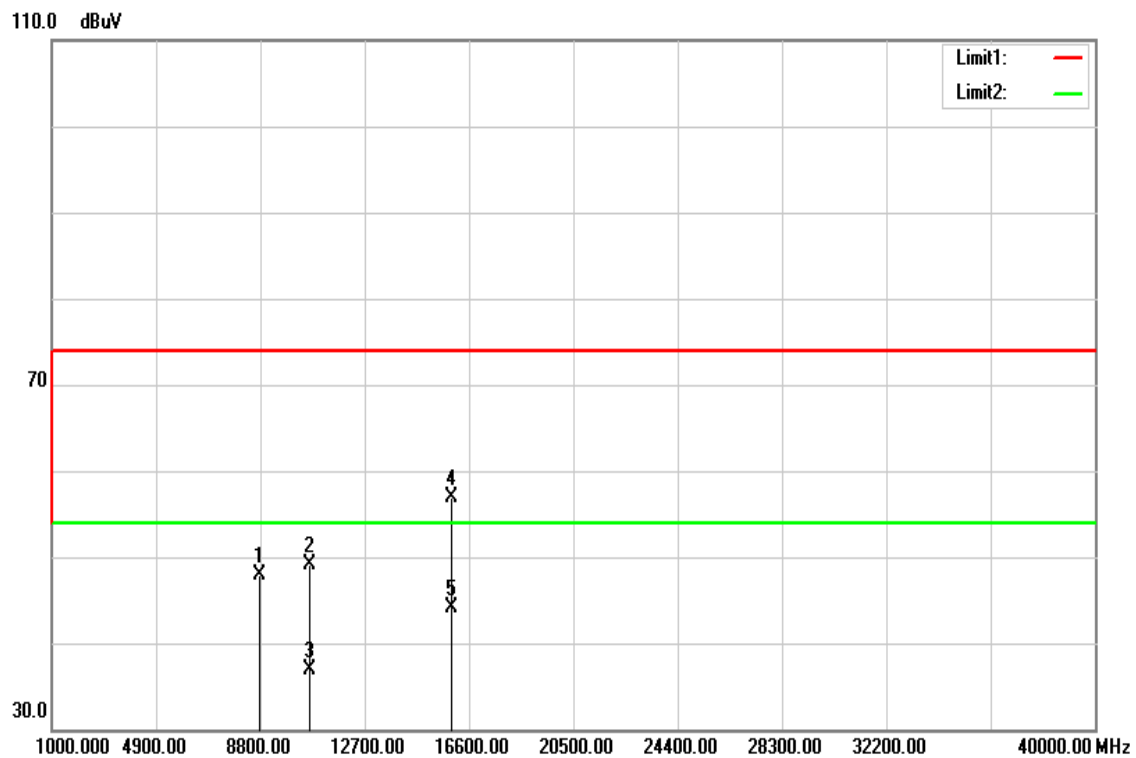

Operation Mode: Tx / IEEE 802.11n HT 40 MHz mode / CH High
Temperature: 27°C
Humidity: 53% RH
Test Date: April 14, 2016
Tested by: Jason Lu
Polarity: Ver. / Hor.

Frequency (MHz)	Reading (dBuV)	Correction (dB/m)	Result (dBuV/m)	Limit (dBuV/m)	Margin (dB)	Remark	Ant.Pol. (H/V)
8695.000	35.23	13.73	48.96	74.00	-25.04	peak	V
10620.000	32.19	17.06	49.25	74.00	-24.75	peak	V
10620.000	21.06	17.06	38.12	74.00	-35.88	peak	V
15930.000	36.06	19.37	55.43	74.00	-18.57	peak	V
15930.000	23.74	19.37	43.11	54.00	-10.89	AVG	V
N/A							
8756.000	34.20	13.76	47.96	74.00	-26.04	peak	H
10620.000	31.97	17.06	49.03	74.00	-24.97	peak	H
10620.000	19.94	17.06	37.00	74.00	-37.00	peak	H
15930.000	37.57	19.37	56.94	74.00	-17.06	peak	H
15930.000	24.74	19.37	44.11	54.00	-9.89	AVG	H
N/A							

Remark:

1. Measuring frequencies from 1 GHz to the 10th harmonic of highest fundamental frequency.
2. Radiated emissions measured in frequency above 1000MHz were made with an instrument using peak/average detector mode.
3. Average test would be performed if the peak result were greater than the average limit.
4. Data of measurement within this frequency range shown “ --- ” in the table above means the reading of emissions are attenuated more than 20dB below the permissible limits or the field strength is too small to be measured.
5. Measurements above show only up to 6 maximum emissions noted, or would be lesser, with “ N/A ” remark, if no specific emissions from the EUT are recorded (ie: margin>20dB from the applicable limit) and considered that's already beyond the background noise floor.
6. Margin (dB) = Remark result (dBuV/m) – Average limit (dBuV/m).

U-NII-2C
Tx / IEEE 802.11a mode / CH Low

Polarity: Vertical

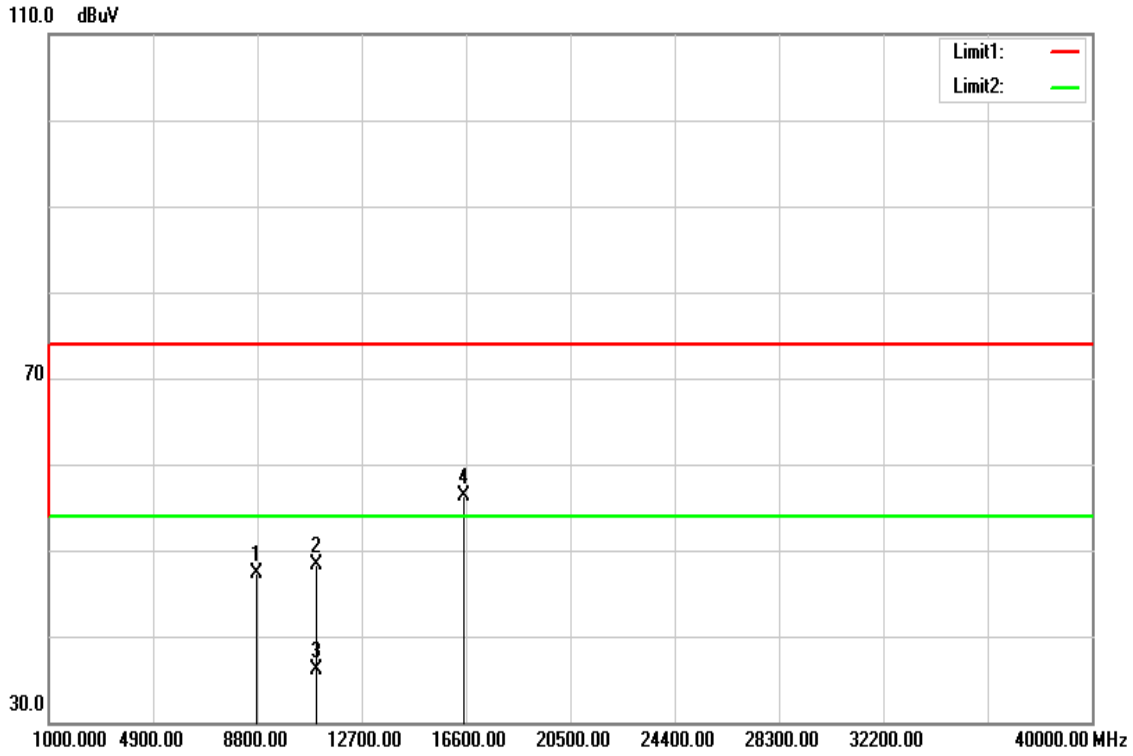

Polarity: Horizontal

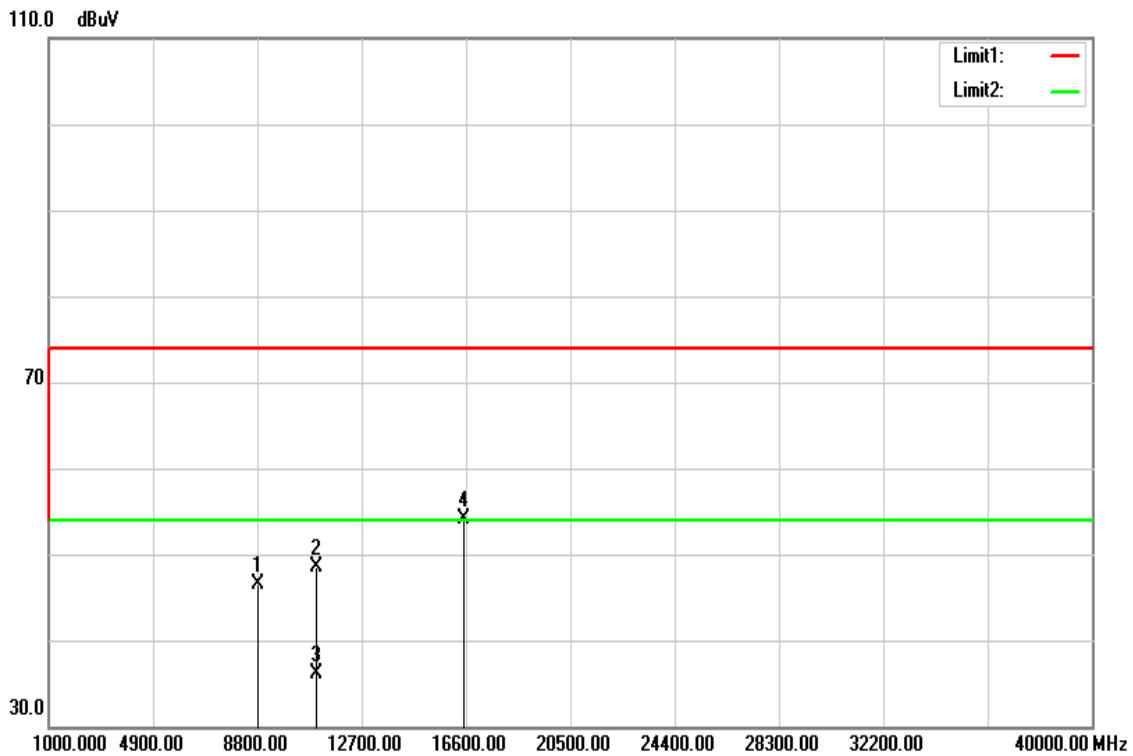

Operation Mode: Tx / IEEE 802.11a mode / CH Low **Test Date:** April 13, 2016
Temperature: 27°C **Tested by:** Jason Lu
Humidity: 53% RH **Polarity:** Ver. / Hor.

Frequency (MHz)	Reading (dBuV)	Correction (dB/m)	Result (dBuV/m)	Limit (dBuV/m)	Margin (dB)	Remark	Ant.Pol. (H/V)
8749.000	33.46	13.75	47.21	74.00	-26.79	peak	V
11000.000	31.64	16.73	48.37	74.00	-25.63	peak	V
11000.000	19.42	16.73	36.15	54.00	-17.85	AVG	V
16500.000	34.88	21.39	56.27	74.00	-17.73	peak	V
N/A							
8831.000	32.71	13.79	46.50	74.00	-27.50	peak	H
11000.000	31.68	16.73	48.41	74.00	-25.59	peak	H
11000.000	19.46	16.73	36.19	54.00	-17.81	AVG	H
16500.000	32.75	21.39	54.14	74.00	-19.86	peak	H
N/A							

Remark:

1. *Measuring frequencies from 1 GHz to the 10th harmonic of highest fundamental frequency.*
2. *Radiated emissions measured in frequency above 1000MHz were made with an instrument using peak/average detector mode.*
3. *Average test would be performed if the peak result were greater than the average limit or as required by the applicant.*
4. *Data of measurement within this frequency range shown “ --- ” in the table above means the reading of emissions are attenuated more than 20dB below the permissible limits or the field strength is too small to be measured.*
5. *Measurements above show only up to 6 maximum emissions noted, or would be lesser, with “ N/A ” remark, if no specific emissions from the EUT are recorded (ie: margin>20dB from the applicable limit) and considered that's already beyond the background noise floor.*
6. *Margin (dB) = Remark result (dBuV/m) – Average limit (dBuV/m).*

Tx / IEEE 802.11a mode / CH Mid

Polarity: Vertical

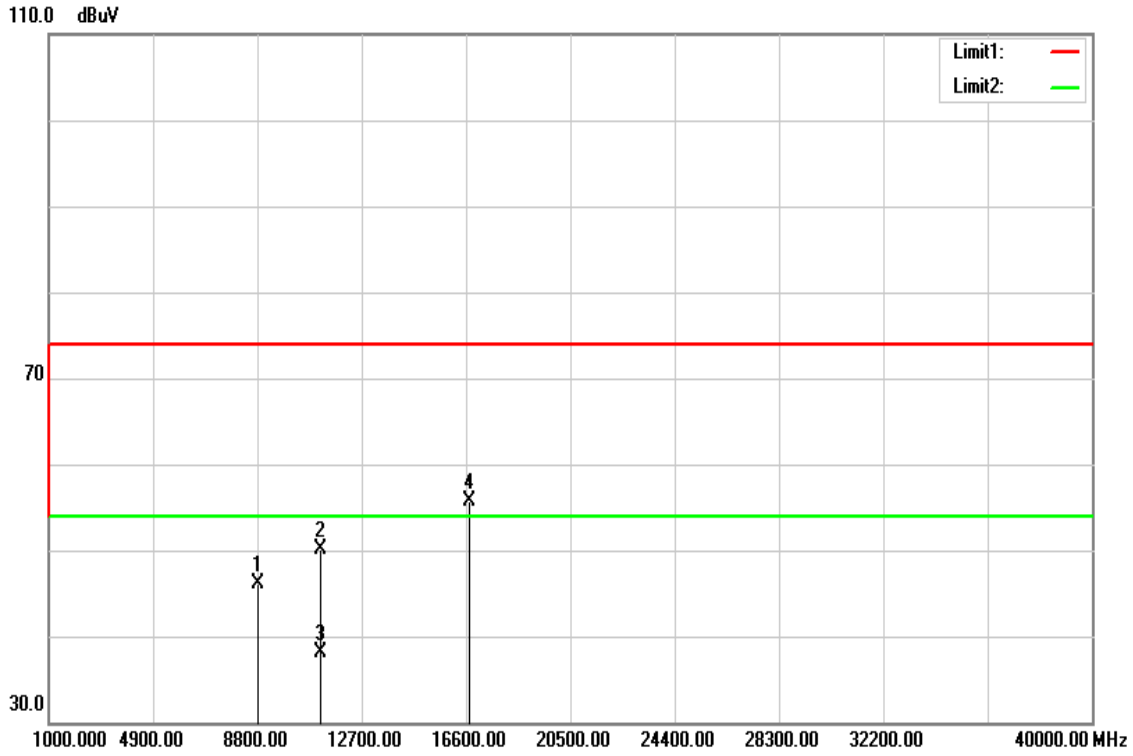

Polarity: Horizontal

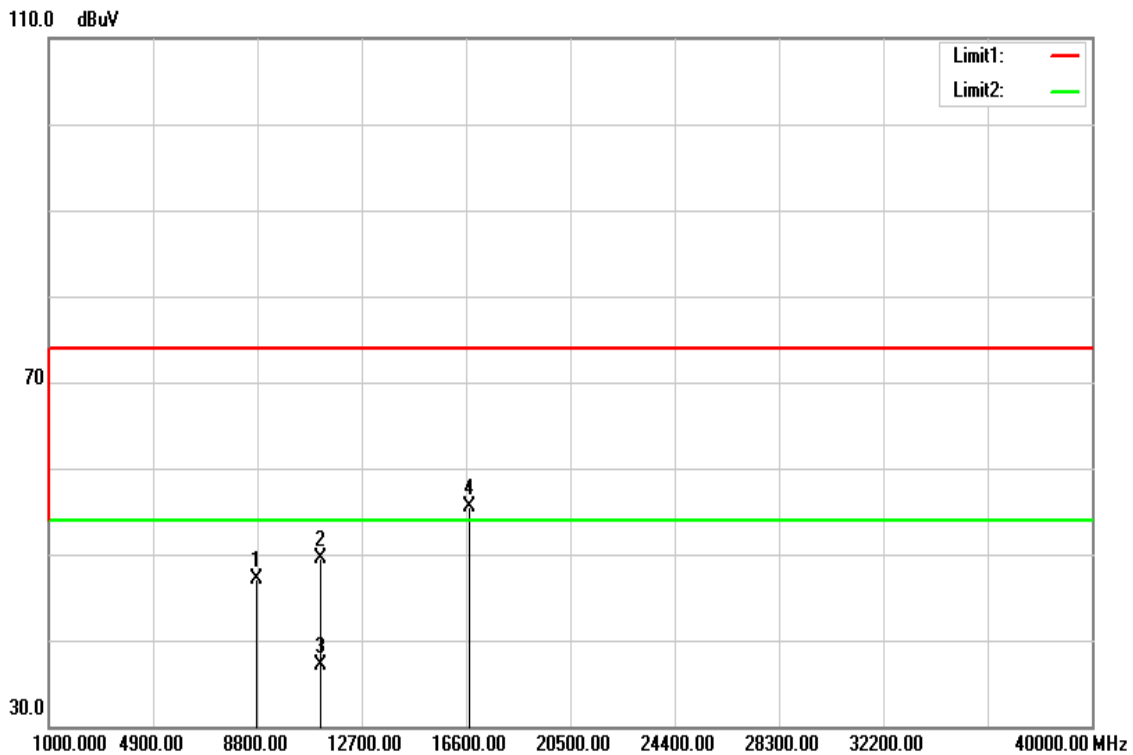

Operation Mode: Tx / IEEE 802.11a mode / CH Mid

Test Date: April 13, 2016

Temperature: 27°C

Tested by: Jason Lu

Humidity: 53% RH

Polarity: Ver. / Hor.

Frequency (MHz)	Reading (dBuV)	Correction (dB/m)	Result (dBuV/m)	Limit (dBuV/m)	Margin (dB)	Remark	Ant.Pol. (H/V)
8806.000	32.41	13.78	46.19	74.00	-27.81	peak	V
11160.000	33.33	16.75	50.08	74.00	-23.92	peak	V
11160.000	21.41	16.75	38.16	54.00	-15.84	AVG	V
16740.000	32.92	22.82	55.74	74.00	-18.26	peak	V
N/A							
8759.000	33.30	13.76	47.06	74.00	-26.94	peak	H
11160.000	32.72	16.75	49.47	74.00	-24.53	peak	H
11160.000	20.44	16.75	37.19	54.00	-16.81	AVG	H
16740.000	32.76	22.82	55.58	74.00	-18.42	peak	H
N/A							

Remark:

1. *Measuring frequencies from 1 GHz to the 10th harmonic of highest fundamental frequency.*
2. *Radiated emissions measured in frequency above 1000MHz were made with an instrument using peak/average detector mode.*
3. *Average test would be performed if the peak result were greater than the average limit or as required by the applicant.*
4. *Data of measurement within this frequency range shown " --- " in the table above means the reading of emissions are attenuated more than 20dB below the permissible limits or the field strength is too small to be measured.*
5. *Measurements above show only up to 6 maximum emissions noted, or would be lesser, with " N/A " remark, if no specific emissions from the EUT are recorded (ie: margin>20dB from the applicable limit) and considered that's already beyond the background noise floor.*
6. *Margin (dB) = Remark result (dBuV/m) – Average limit (dBuV/m).*

Tx / IEEE 802.11a mode / CH High

Polarity: Vertical

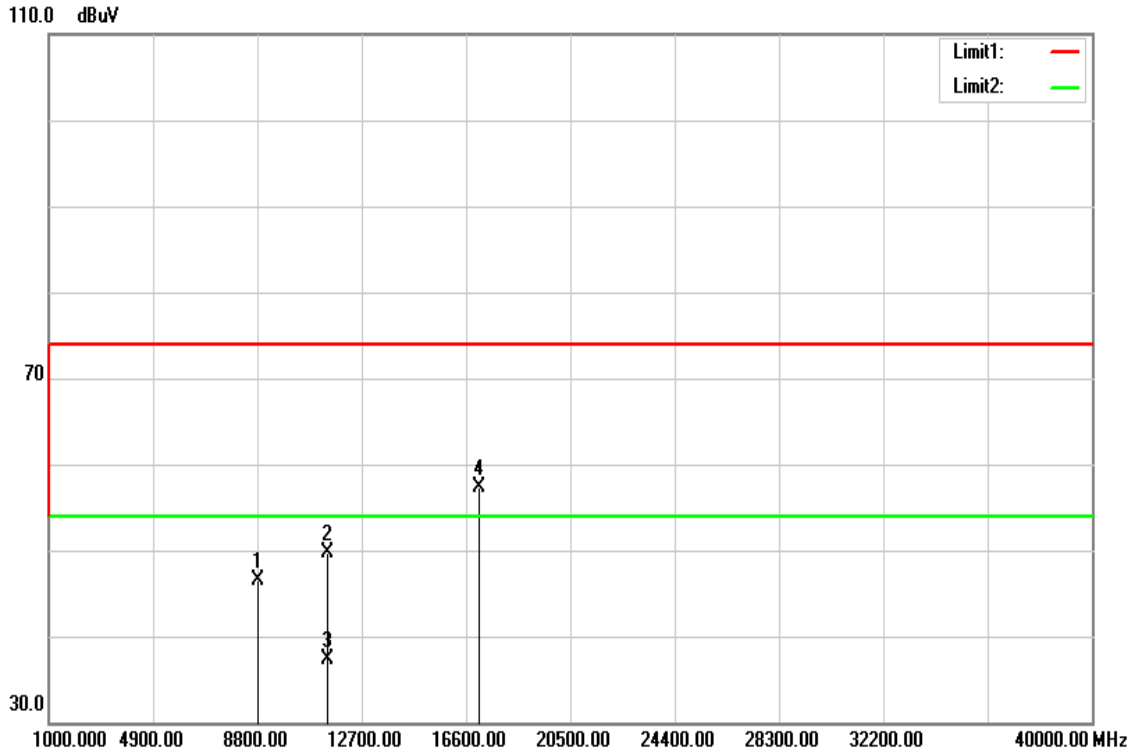

Polarity: Horizontal

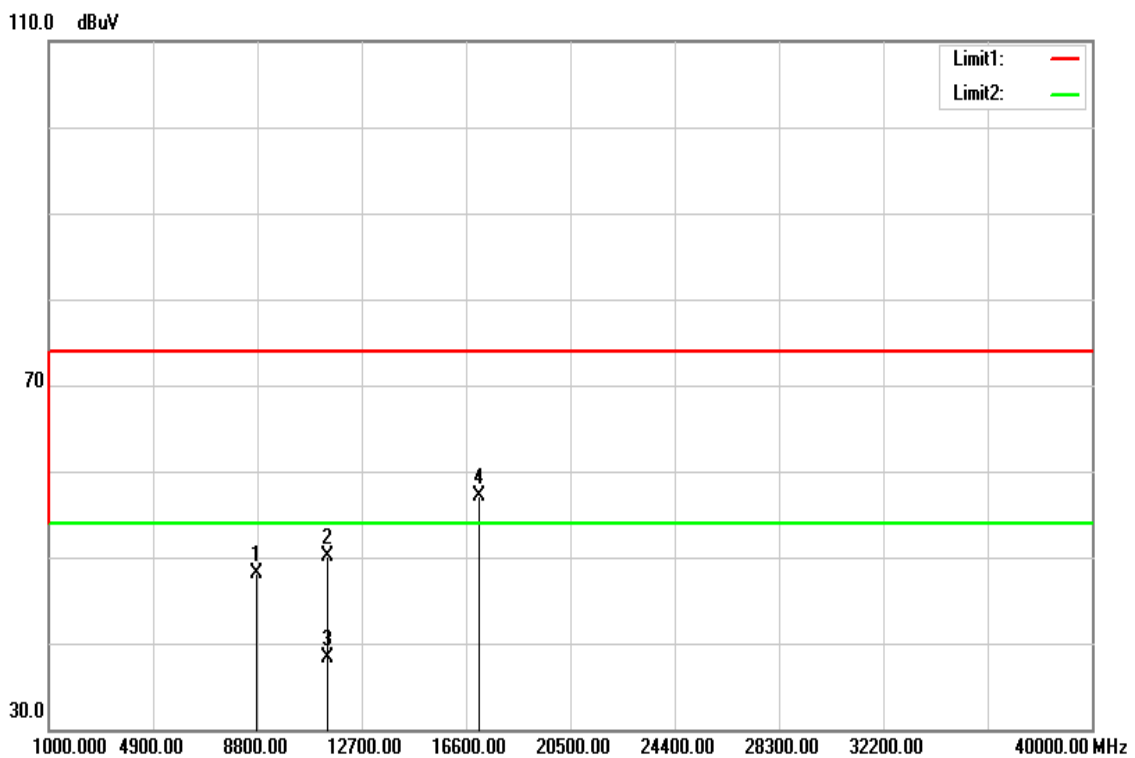

Operation Mode: Tx / IEEE 802.11a mode / CH High

Test Date: December 8, 2015

Temperature: 27°C

Tested by: Jason Lu

Humidity: 53% RH

Polarity: Ver. / Hor.

Frequency (MHz)	Reading (dBuV)	Correction (dB/m)	Result (dBuV/m)	Limit (dBuV/m)	Margin (dB)	Remark	Ant.Pol. (H/V)
8816.000	32.78	13.79	46.57	74.00	-27.43	peak	V
11400.000	32.91	16.77	49.68	74.00	-24.32	peak	V
11400.000	20.49	16.77	37.26	54.00	-16.74	AVG	V
17100.000	32.46	24.75	57.21	74.00	-16.79	peak	V
N/A							
8759.000	34.33	13.76	48.09	74.00	-25.91	peak	H
11400.000	33.32	16.77	50.09	74.00	-23.91	peak	H
11400.000	21.45	16.77	38.22	54.00	-15.78	AVG	H
17100.000	32.42	24.75	57.17	74.00	-16.83	peak	H
N/A							

Remark:

1. Measuring frequencies from 1 GHz to the 10th harmonic of highest fundamental frequency.
2. Radiated emissions measured in frequency above 1000MHz were made with an instrument using peak/average detector mode.
3. Average test would be performed if the peak result were greater than the average limit or as required by the applicant.
4. Data of measurement within this frequency range shown “ --- ” in the table above means the reading of emissions are attenuated more than 20dB below the permissible limits or the field strength is too small to be measured.
5. Measurements above show only up to 6 maximum emissions noted, or would be lesser, with “ N/A ” remark, if no specific emissions from the EUT are recorded (ie: margin>20dB from the applicable limit) and considered that's already beyond the background noise floor.
6. Margin (dB) = Remark result (dBuV/m) – Average limit (dBuV/m).

Tx / IEEE 802.11n HT 20 MHz mode / CH Low

Polarity: Vertical

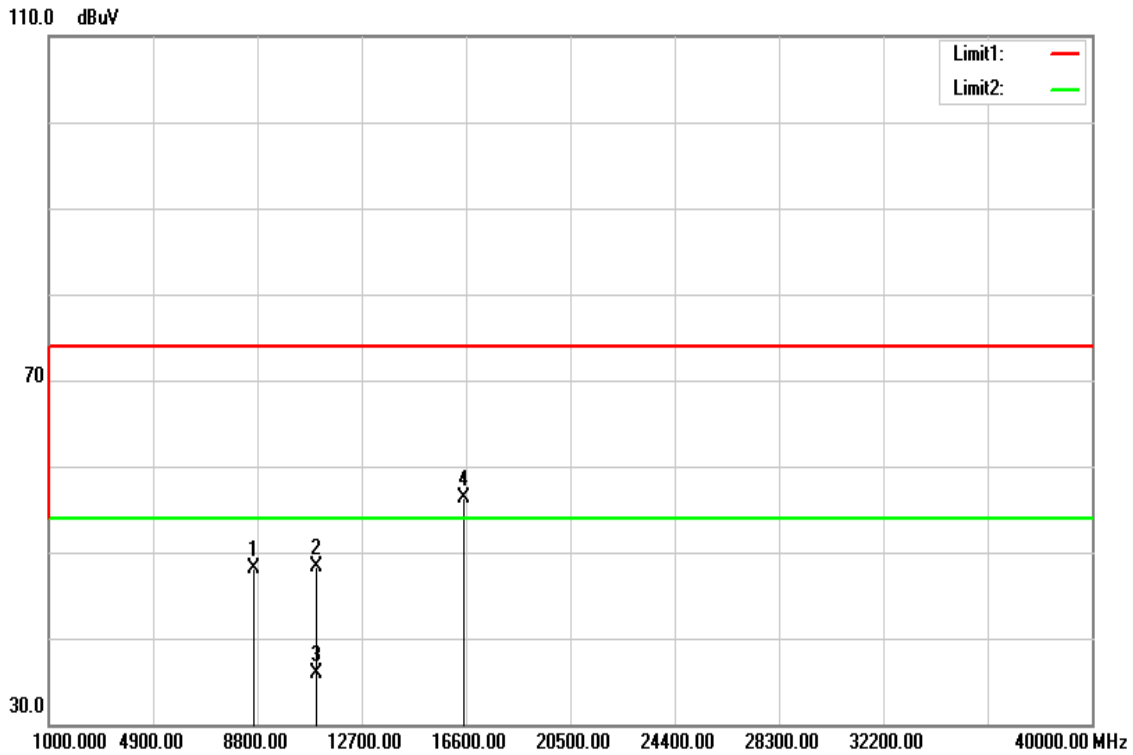

Polarity: Horizontal

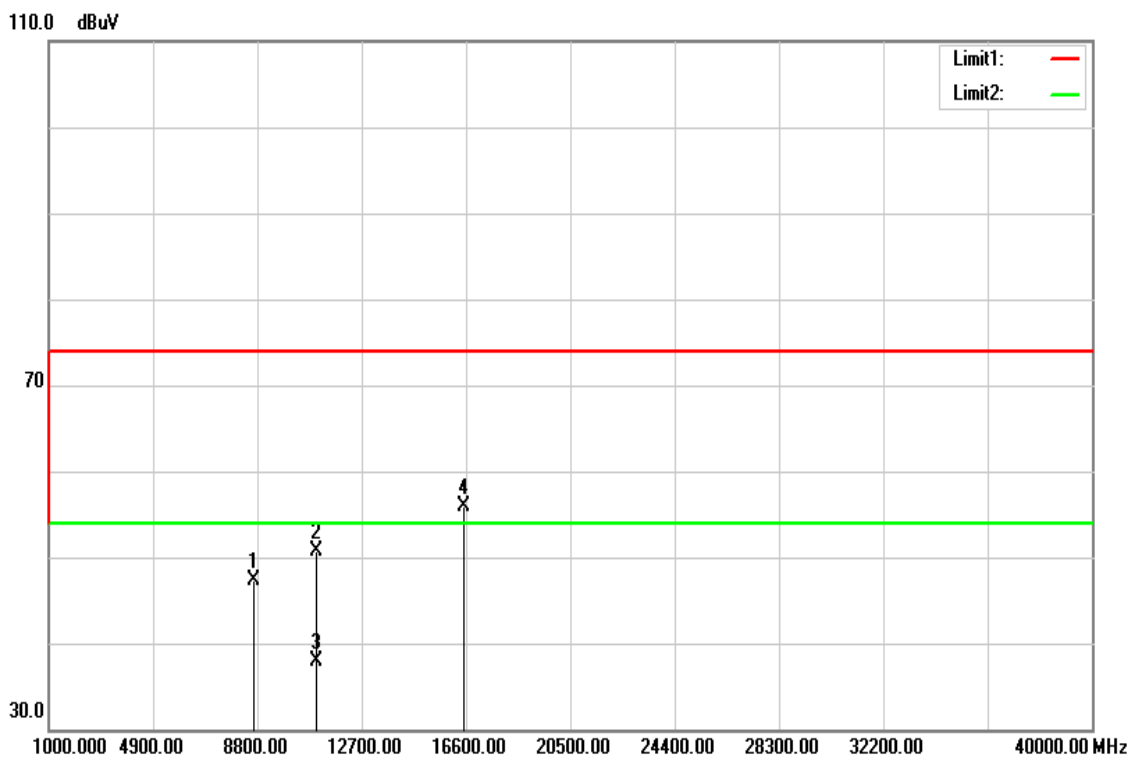

Operation Mode: Tx / IEEE 802.11n HT 20 MHz mode / CH Low **Test Date:** April 13, 2016
Temperature: 27°C **Tested by:** Jason Lu
Humidity: 53% RH **Polarity:** Ver. / Hor.

Frequency (MHz)	Reading (dBuV)	Correction (dB/m)	Result (dBuV/m)	Limit (dBuV/m)	Margin (dB)	Remark	Ant.Pol. (H/V)
8655.000	34.42	13.71	48.13	74.00	-25.87	peak	V
11000.000	31.53	16.73	48.26	74.00	-25.74	peak	V
11000.000	19.22	16.73	35.95	54.00	-18.05	AVG	V
16500.000	35.01	21.39	56.40	74.00	-17.60	peak	V
N/A							
8677.000	33.57	13.72	47.29	74.00	-26.71	peak	H
11000.000	33.89	16.73	50.62	74.00	-23.38	peak	H
11000.000	21.23	16.73	37.96	54.00	-16.04	AVG	H
16500.000	34.42	21.39	55.81	74.00	-18.19	peak	H
N/A							

Remark:

1. Measuring frequencies from 1 GHz to the 10th harmonic of highest fundamental frequency.
2. Radiated emissions measured in frequency above 1000MHz were made with an instrument using peak/average detector mode.
3. Average test would be performed if the peak result were greater than the average limit or as required by the applicant.
4. Data of measurement within this frequency range shown " --- " in the table above means the reading of emissions are attenuated more than 20dB below the permissible limits or the field strength is too small to be measured.
5. Measurements above show only up to 6 maximum emissions noted, or would be lesser, with " N/A " remark, if no specific emissions from the EUT are recorded (ie: margin>20dB from the applicable limit) and considered that's already beyond the background noise floor.
6. Margin (dB) = Remark result (dBuV/m) – Average limit (dBuV/m).

Tx / IEEE 802.11n HT 20 MHz mode / CH Mid

Polarity: Vertical

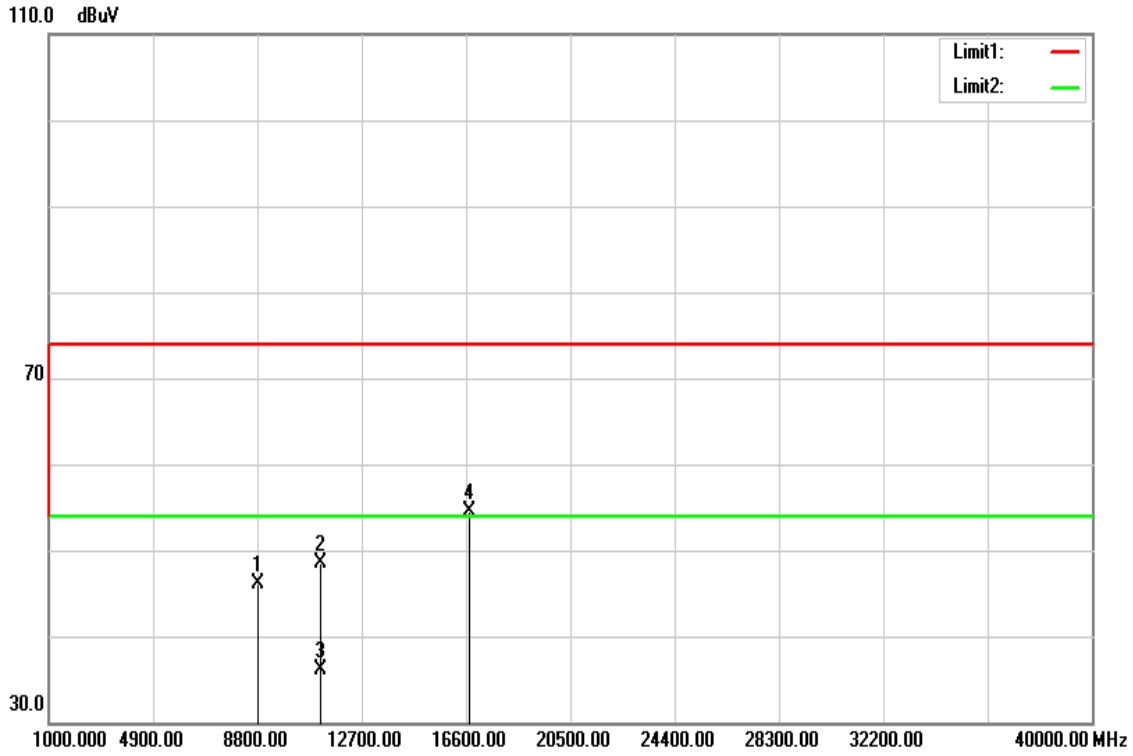

Polarity: Horizontal

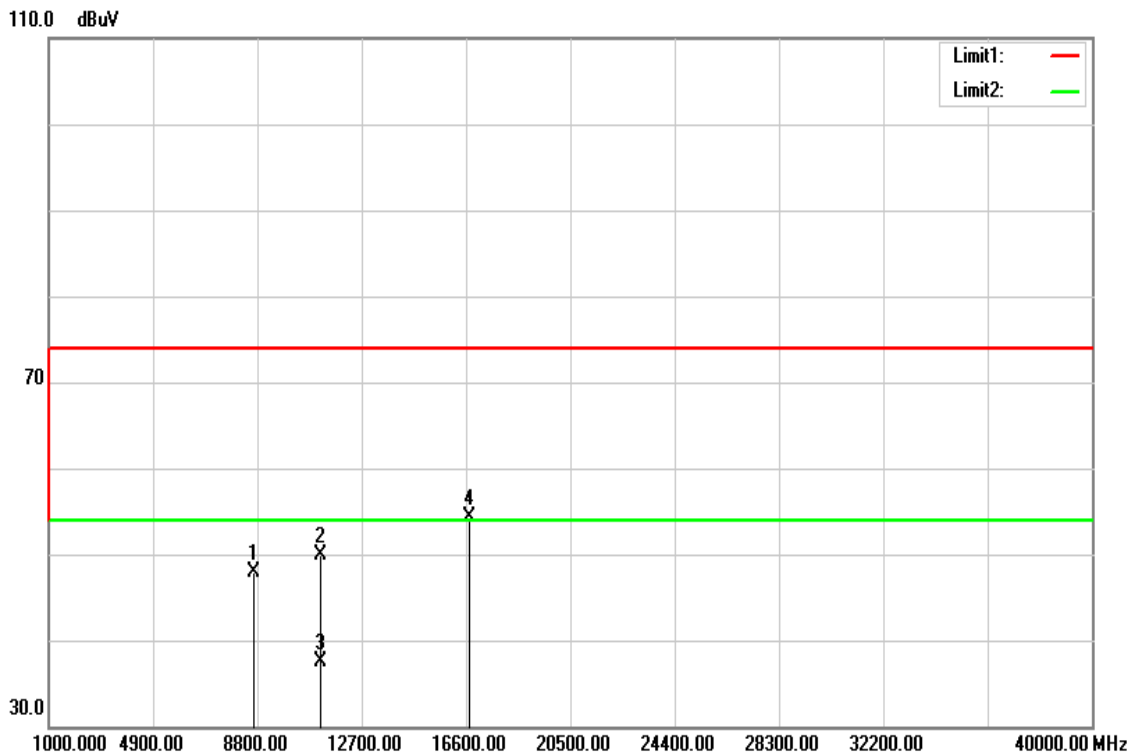

Operation Mode: Tx / IEEE 802.11n HT 20 MHz mode / CH Mid **Test Date:** April 13, 2016
Temperature: 27°C **Tested by:** Jason Lu
Humidity: 53% RH **Polarity:** Ver. / Hor.

Frequency (MHz)	Reading (dBuV)	Correction (dB/m)	Result (dBuV/m)	Limit (dBuV/m)	Margin (dB)	Remark	Ant.Pol. (H/V)
8846.000	32.33	13.80	46.13	74.00	-27.87	peak	V
11160.000	31.71	16.75	48.46	74.00	-25.54	peak	V
11160.000	19.36	16.75	36.11	54.00	-17.89	AVG	V
16740.000	31.76	22.82	54.58	74.00	-19.42	peak	V
N/A							
8645.000	34.17	13.71	47.88	74.00	-26.12	peak	H
11160.000	33.10	16.75	49.85	74.00	-24.15	peak	H
11160.000	20.80	16.75	37.55	54.00	-16.45	AVG	H
16740.000	31.43	22.82	54.25	74.00	-19.75	peak	H
N/A							

Remark:

1. Measuring frequencies from 1 GHz to the 10th harmonic of highest fundamental frequency.
2. Radiated emissions measured in frequency above 1000MHz were made with an instrument using peak/average detector mode.
3. Average test would be performed if the peak result were greater than the average limit or as required by the applicant.
4. Data of measurement within this frequency range shown " --- " in the table above means the reading of emissions are attenuated more than 20dB below the permissible limits or the field strength is too small to be measured.
5. Measurements above show only up to 6 maximum emissions noted, or would be lesser, with " N/A " remark, if no specific emissions from the EUT are recorded (ie: margin>20dB from the applicable limit) and considered that's already beyond the background noise floor.
6. Margin (dB) = Remark result (dBuV/m) – Average limit (dBuV/m).

Tx / IEEE 802.11n HT 20 MHz mode / CH High

Polarity: Vertical

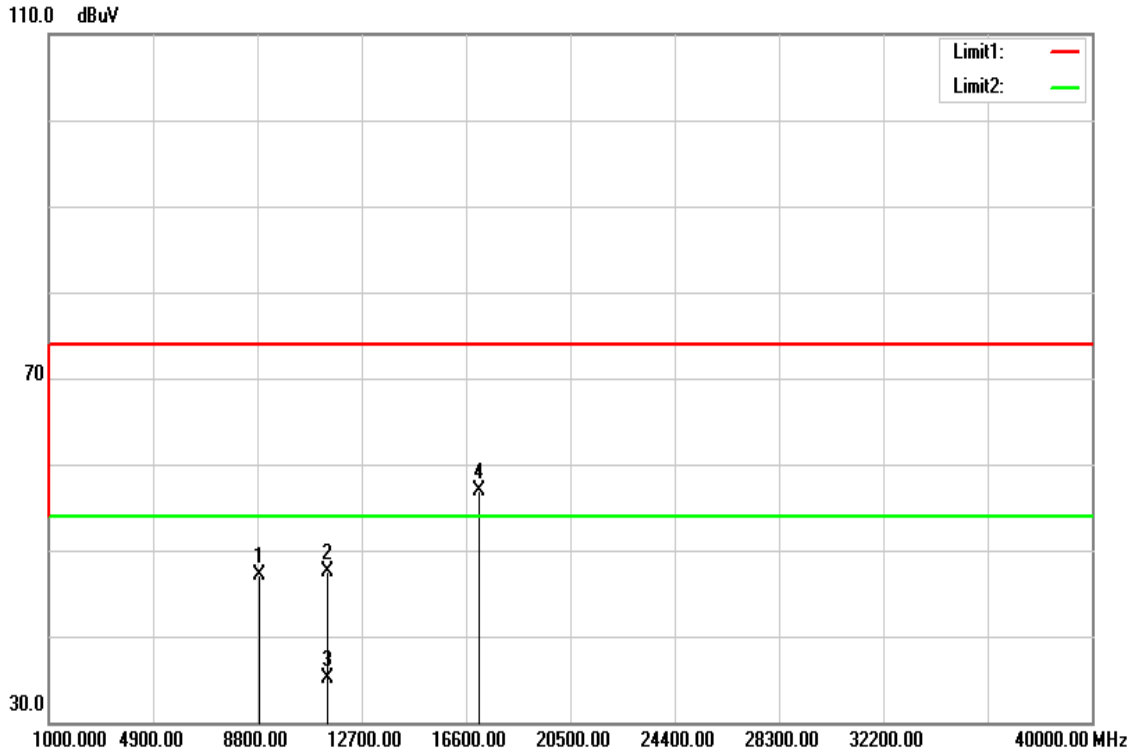

Polarity: Horizontal

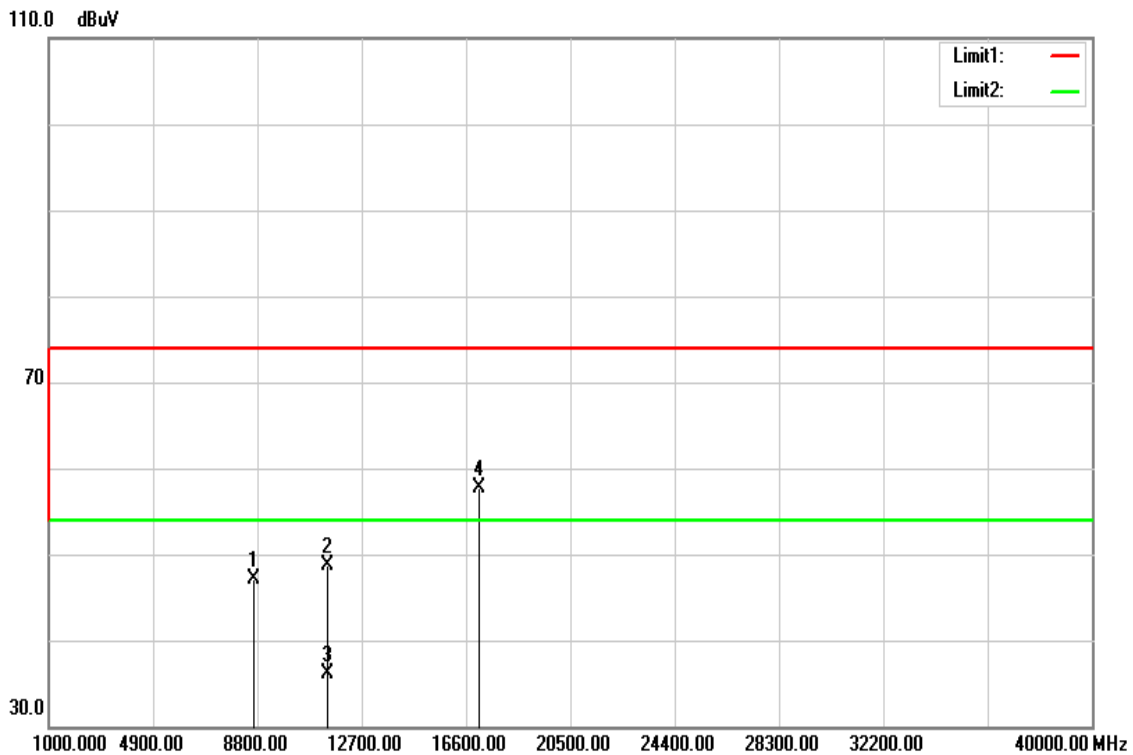

Operation Mode: Tx / IEEE 802.11n HT 20 MHz mode / CH High
Temperature: 27°C
Humidity: 53% RH
Test Date: April 13, 2016
Tested by: Jason Lu
Polarity: Ver. / Hor.

Frequency (MHz)	Reading (dBuV)	Correction (dB/m)	Result (dBuV/m)	Limit (dBuV/m)	Margin (dB)	Remark	Ant.Pol. (H/V)
8861.000	33.26	13.81	47.07	74.00	-26.93	peak	V
11400.000	30.80	16.77	47.57	74.00	-26.43	peak	V
11400.000	18.39	16.77	35.16	54.00	-18.84	AVG	V
17100.000	32.16	24.75	56.91	74.00	-17.09	peak	V
N/A							
8669.000	33.30	13.72	47.02	74.00	-26.98	peak	H
11400.000	31.90	16.77	48.67	74.00	-25.33	peak	H
11400.000	19.25	16.77	36.02	54.00	-17.98	AVG	H
17100.000	32.99	24.75	57.74	74.00	-16.26	peak	H
N/A							

Remark:

1. Measuring frequencies from 1 GHz to the 10th harmonic of highest fundamental frequency.
2. Radiated emissions measured in frequency above 1000MHz were made with an instrument using peak/average detector mode.
3. Average test would be performed if the peak result were greater than the average limit or as required by the applicant.
4. Data of measurement within this frequency range shown " --- " in the table above means the reading of emissions are attenuated more than 20dB below the permissible limits or the field strength is too small to be measured.
5. Measurements above show only up to 6 maximum emissions noted, or would be lesser, with " N/A " remark, if no specific emissions from the EUT are recorded (ie: margin>20dB from the applicable limit) and considered that's already beyond the background noise floor.
6. Margin (dB) = Remark result (dBuV/m) – Average limit (dBuV/m).

Tx / IEEE 802.11n HT 40 MHz mode / CH Low

Polarity: Vertical

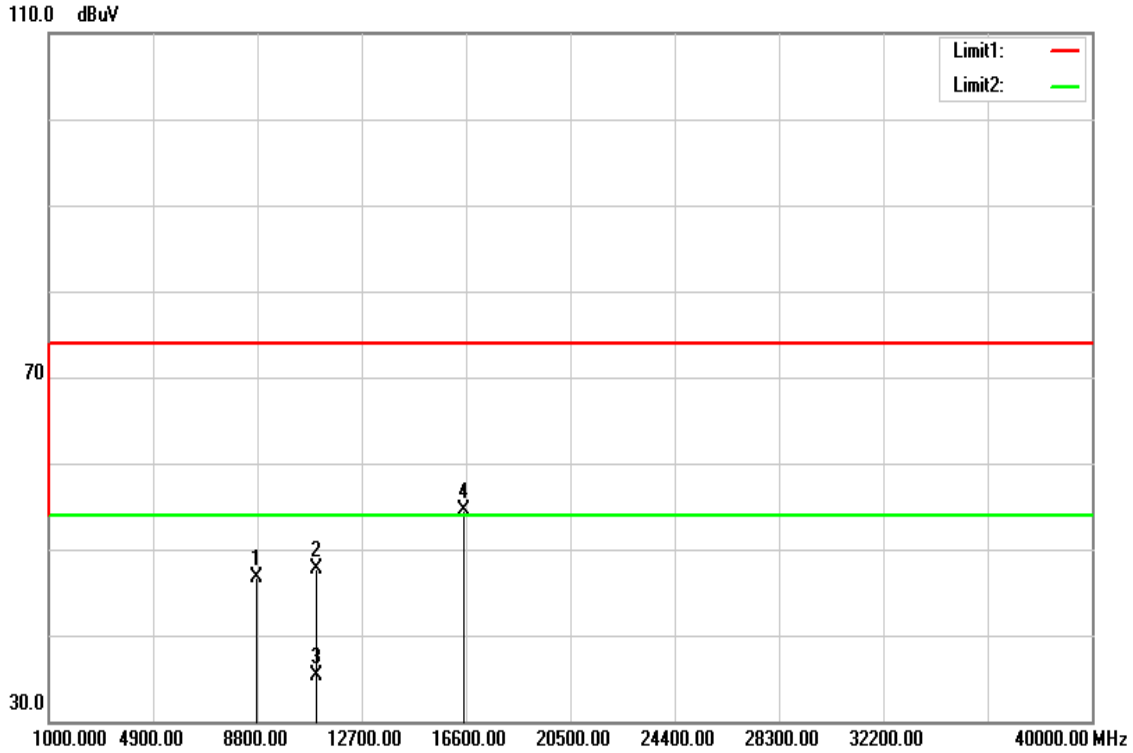

Polarity: Horizontal

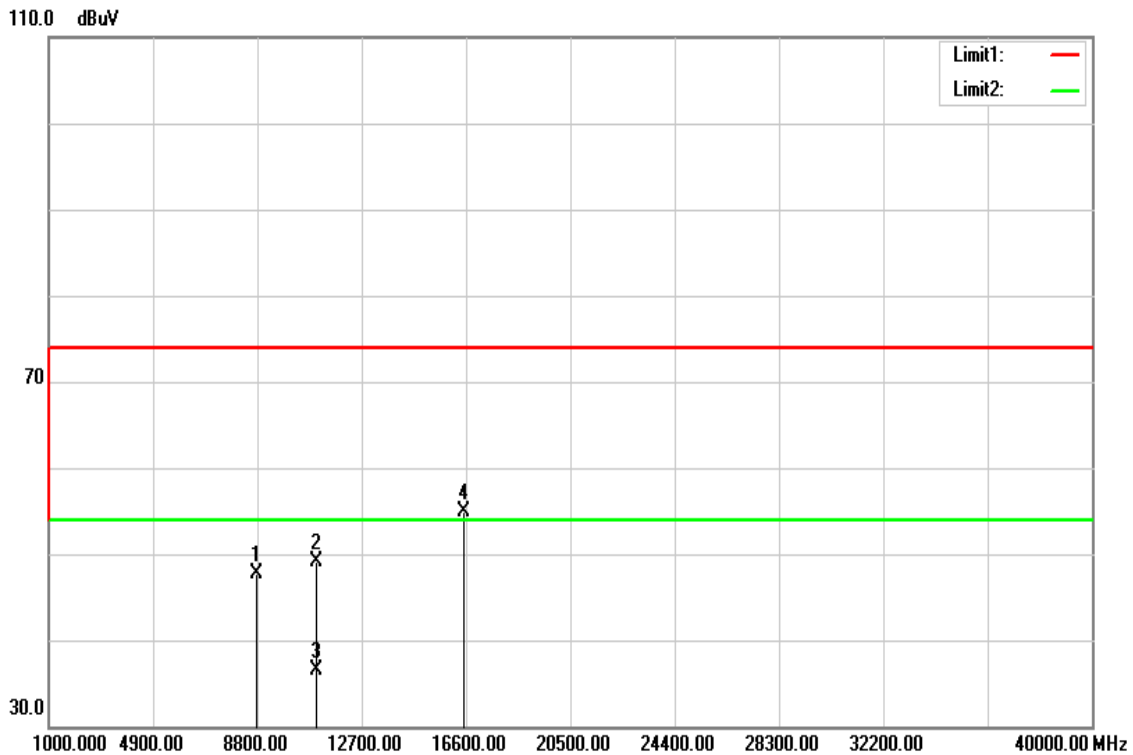

Operation Mode: Tx / IEEE 802.11n HT 40 MHz mode / CH Low **Test Date:** April 14, 2016
Temperature: 27°C **Tested by:** Jason Lu
Humidity: 53% RH **Polarity:** Ver. / Hor.

Frequency (MHz)	Reading (dBuV)	Correction (dB/m)	Result (dBuV/m)	Limit (dBuV/m)	Margin (dB)	Remark	Ant.Pol. (H/V)
8766.000	33.04	13.76	46.80	74.00	-27.20	peak	V
11020.000	30.90	16.73	47.63	74.00	-26.37	peak	V
11020.000	18.50	16.73	35.23	54.00	-18.77	AVG	V
16530.000	32.95	21.57	54.52	74.00	-19.48	peak	V
N/A							
8769.000	33.95	13.76	47.71	74.00	-26.29	peak	H
11020.000	32.30	16.73	49.03	74.00	-24.97	peak	H
11020.000	19.82	16.73	36.55	54.00	-17.45	AVG	H
16530.000	33.34	21.57	54.91	74.00	-19.09	peak	H
N/A							

Remark:

1. Measuring frequencies from 1 GHz to the 10th harmonic of highest fundamental frequency.
2. Radiated emissions measured in frequency above 1000MHz were made with an instrument using peak/average detector mode.
3. Average test would be performed if the peak result were greater than the average limit or as required by the applicant.
4. Data of measurement within this frequency range shown " --- " in the table above means the reading of emissions are attenuated more than 20dB below the permissible limits or the field strength is too small to be measured.
5. Measurements above show only up to 6 maximum emissions noted, or would be lesser, with " N/A " remark, if no specific emissions from the EUT are recorded (ie: margin>20dB from the applicable limit) and considered that's already beyond the background noise floor.
6. Margin (dB) = Remark result (dBuV/m) – Average limit (dBuV/m).

Tx / IEEE 802.11n HT 40 MHz mode / CH Mid

Polarity: Vertical

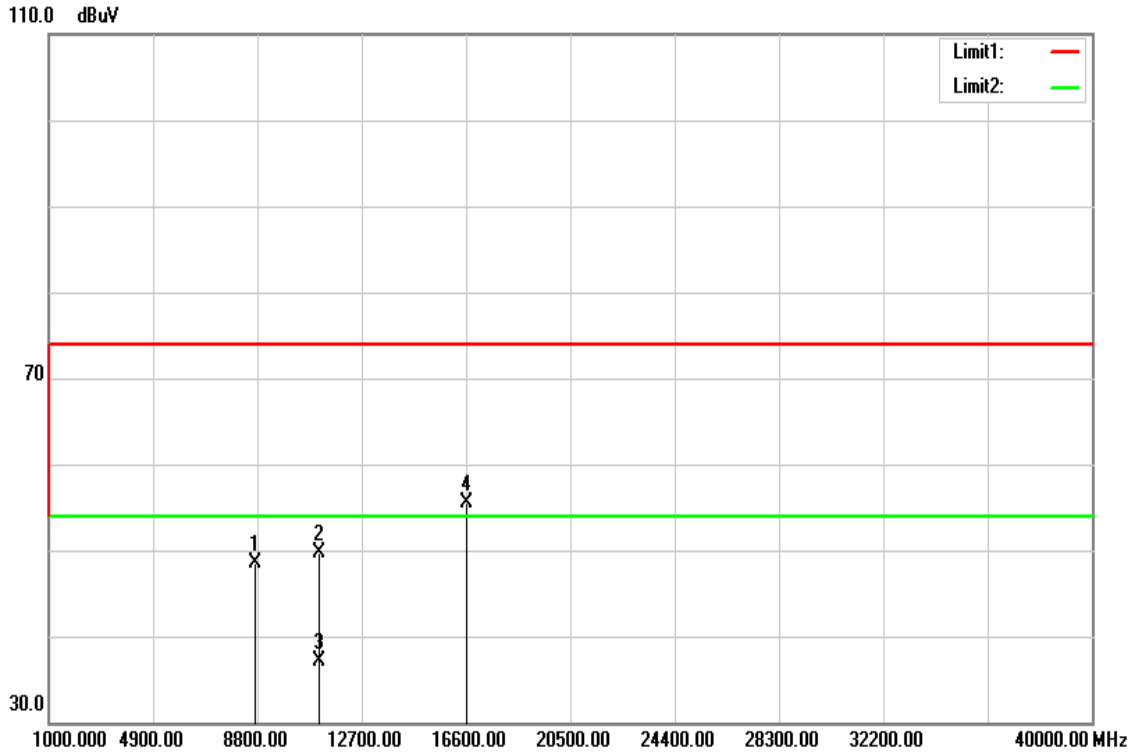

Polarity: Horizontal

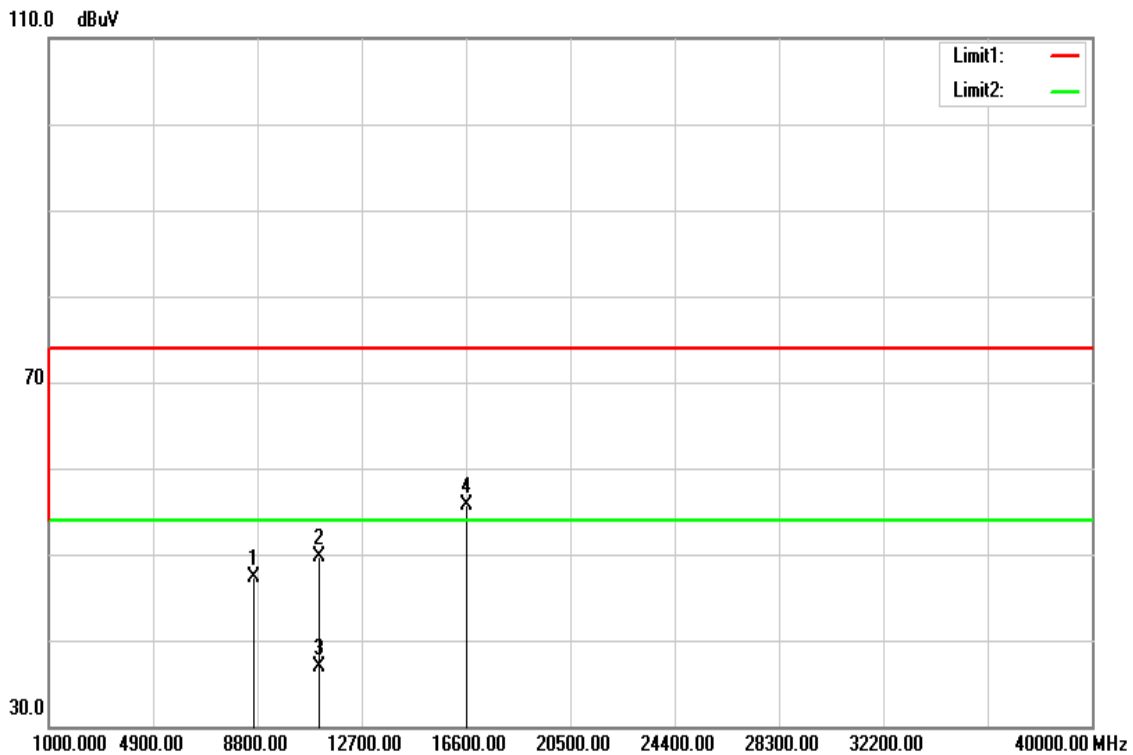

Operation Mode: Tx / IEEE 802.11n HT 40 MHz mode / CH Mid **Test Date:** April 14, 2016
Temperature: 27°C **Tested by:** Jason Lu
Humidity: 53% RH **Polarity:** Ver. / Hor.

Frequency (MHz)	Reading (dBuV)	Correction (dB/m)	Result (dBuV/m)	Limit (dBuV/m)	Margin (dB)	Remark	Ant.Pol. (H/V)
8697.000	34.86	13.73	48.59	74.00	-25.41	peak	V
11100.000	32.92	16.74	49.66	74.00	-24.34	peak	V
11100.000	20.38	16.74	37.12	54.00	-16.88	AVG	V
16650.000	33.22	22.28	55.50	74.00	-18.50	peak	V
N/A							
8679.000	33.67	13.72	47.39	74.00	-26.61	peak	H
11100.000	33.06	16.74	49.80	74.00	-24.20	peak	H
11100.000	20.08	16.74	36.82	54.00	-17.18	AVG	H
16650.000	33.38	22.28	55.66	74.00	-18.34	peak	H
N/A							

Remark:

1. Measuring frequencies from 1 GHz to the 10th harmonic of highest fundamental frequency.
2. Radiated emissions measured in frequency above 1000MHz were made with an instrument using peak/average detector mode.
3. Average test would be performed if the peak result were greater than the average limit or as required by the applicant.
4. Data of measurement within this frequency range shown " --- " in the table above means the reading of emissions are attenuated more than 20dB below the permissible limits or the field strength is too small to be measured.
5. Measurements above show only up to 6 maximum emissions noted, or would be lesser, with " N/A " remark, if no specific emissions from the EUT are recorded (ie: margin>20dB from the applicable limit) and considered that's already beyond the background noise floor.
6. Margin (dB) = Remark result (dBuV/m) – Average limit (dBuV/m).

Tx / IEEE 802.11n HT 40 MHz mode / CH High

Polarity: Vertical

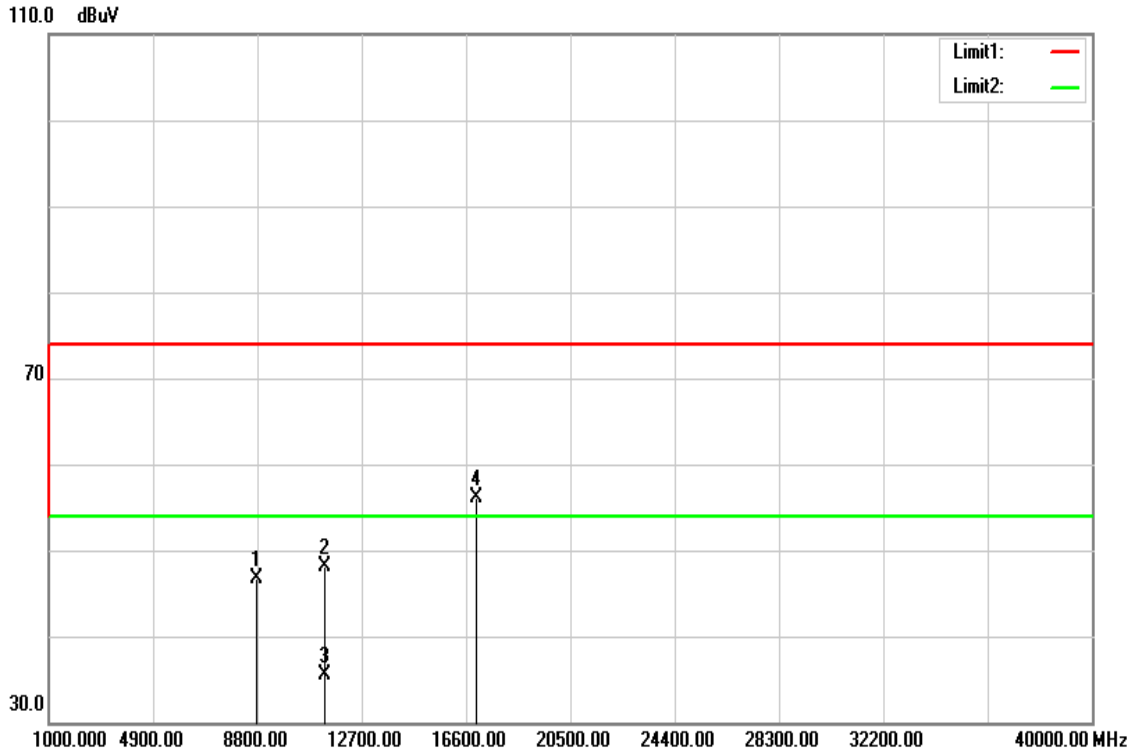

Polarity: Horizontal

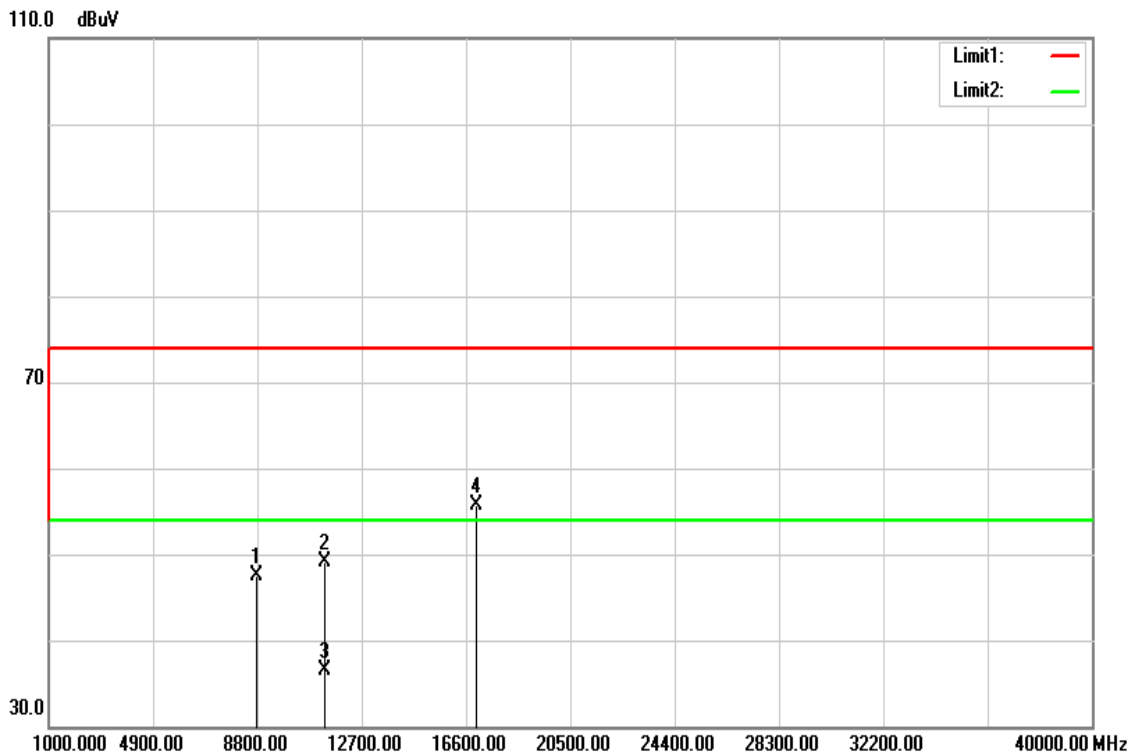

Operation Mode: Tx / IEEE 802.11n HT 40 MHz mode / CH High
Temperature: 27°C
Humidity: 53% RH

Test Date: April 14, 2016
Tested by: Jason Lu
Polarity: Ver. / Hor.

Frequency (MHz)	Reading (dBuV)	Correction (dB/m)	Result (dBuV/m)	Limit (dBuV/m)	Margin (dB)	Remark	Ant.Pol. (H/V)
8759.000	33.01	13.76	46.77	74.00	-27.23	peak	V
11340.000	31.42	16.76	48.18	74.00	-25.82	peak	V
11340.000	18.73	16.76	35.49	54.00	-18.51	AVG	V
17010.000	31.68	24.40	56.08	74.00	-17.92	peak	V
N/A							
8759.000	33.81	13.76	47.57	74.00	-26.43	peak	H
11340.000	32.26	16.76	49.02	74.00	-24.98	peak	H
11340.000	19.79	16.76	36.55	54.00	-17.45	AVG	H
17010.000	31.38	24.40	55.78	74.00	-18.22	peak	H
N/A							

Remark:

1. Measuring frequencies from 1 GHz to the 10th harmonic of highest fundamental frequency.
2. Radiated emissions measured in frequency above 1000MHz were made with an instrument using peak/average detector mode.
3. Average test would be performed if the peak result were greater than the average limit or as required by the applicant.
4. Data of measurement within this frequency range shown “ --- ” in the table above means the reading of emissions are attenuated more than 20dB below the permissible limits or the field strength is too small to be measured.
5. Measurements above show only up to 6 maximum emissions noted, or would be lesser, with “ N/A ” remark, if no specific emissions from the EUT are recorded (ie: margin>20dB from the applicable limit) and considered that's already beyond the background noise floor.
6. Margin (dB) = Remark result (dBuV/m) – Average limit (dBuV/m).

7.7 POWERLINE CONDUCTED EMISSIONS

LIMIT

According to §15.207(a) & RSS-Gen §7.2.4, except as shown in paragraphs (b) and (c) of this section, for an intentional radiator that is designed to be connected to the public utility (AC) power line, the radio frequency voltage that is conducted back onto the AC power line on any frequency or frequencies within the band 150 kHz to 30 MHz shall not exceed the limits in the following table, as measured using a 50 μ H/50 ohms line impedance stabilization network (LISN). Compliance with the provisions of this paragraph shall be based on the measurement of the radio frequency voltage between each power line and ground at the power terminal. The lower limit applies at the boundary between the frequency ranges.

Frequency Range (MHz)	Limits (dB μ V)	
	Quasi-peak	Average
0.15 to 0.50	66 to 56*	56 to 46*
0.50 to 5	56	46
5 to 30	60	50

* Decreases with the logarithm of the frequency.

Test Configuration

See test photographs attached in Appendix II for the actual connections between EUT and support equipment.

TEST PROCEDURE

1. The EUT was placed on a table, which is 0.8m above ground plane.
2. Maximum procedure was performed on the six highest emissions to ensure EUT compliance.
3. Repeat above procedures until all frequency measured were complete.

TEST RESULTS

The initial step in collecting conducted data is a spectrum analyzer peak scan of the measurement range. Significant peaks are then marked as shown on the following data page, and these signals are then quasi-peaked.

Test Data

Operation Mode: Normal Link **Test Date:** April 12, 2016
Temperature: 24°C **Tested by:** Jason Lu
Humidity: 56% RH

Freq. (MHz)	QP Reading (dBuV)	AV Reading (dBuV)	Corr. factor (dB/m)	QP Result (dBuV/m)	AV Result (dBuV/m)	QP Limit (dBuV)	AV Limit (dBuV)	QP Margin (dB)	AV Margin (dB)	Note
0.1700	45.91	34.09	9.77	55.68	43.86	64.96	54.96	-9.28	-11.10	L1
0.1900	44.31	34.05	9.76	54.07	43.81	64.04	54.04	-9.97	-10.23	L1
0.2100	42.15	29.13	9.76	51.91	38.89	63.21	53.21	-11.30	-14.32	L1
0.2340	37.82	24.41	9.76	47.58	34.17	62.31	52.31	-14.73	-18.14	L1
0.3060	35.12	23.43	9.77	44.89	33.20	60.08	50.08	-15.19	-16.88	L1
0.4660	25.44	12.31	9.86	35.30	22.17	56.58	46.58	-21.28	-24.41	L1
0.5380	24.96	14.84	9.96	34.92	24.80	56.00	46.00	-21.08	-21.20	L1
15.1420	25.38	16.63	10.11	35.49	26.74	60.00	50.00	-24.51	-23.26	L1
0.1620	47.18	35.26	9.84	57.02	45.10	65.36	55.36	-8.34	-10.26	L2
0.1700	46.90	36.31	9.84	56.74	46.15	64.96	54.96	-8.22	-8.81	L2
0.1940	46.41	35.04	9.83	56.24	44.87	63.86	53.86	-7.62	-8.99	L2
0.2100	45.16	31.37	9.83	54.99	41.20	63.20	53.21	-8.21	-12.01	L2
0.2380	39.55	25.50	9.83	49.38	35.33	62.16	52.17	-12.78	-16.84	L2
0.2660	39.25	26.22	9.83	49.08	36.05	61.24	51.24	-12.16	-15.19	L2
0.2779	37.23	25.34	9.83	47.06	35.17	60.88	50.88	-13.82	-15.71	L2
0.3060	37.79	24.17	9.83	47.62	34.00	60.08	50.08	-12.46	-16.08	L2
0.4740	29.11	19.43	9.93	39.04	29.36	56.44	46.44	-17.40	-17.08	L2
0.5220	30.41	19.28	10.00	40.41	29.28	56.00	46.00	-15.59	-16.72	L2
0.6100	27.67	15.15	10.12	37.79	25.27	56.00	46.00	-18.21	-20.73	L2

Remark:

1. Measuring frequencies from 0.15 MHz to 30MHz.
2. The emissions measured in frequency range from 0.15 MHz to 30MHz were made with an instrument using Quasi-peak detector and average detector.
3. The IF bandwidth of SPA between 0.15MHz to 30MHz was 10kHz; the IF bandwidth of Test Receiver between 0.15MHz to 30MHz was 9kHz;
4. L1 = Line One (Live Line) / L2 = Line Two (Neutral Line)

Test Plots

Conducted emissions (Line 1)

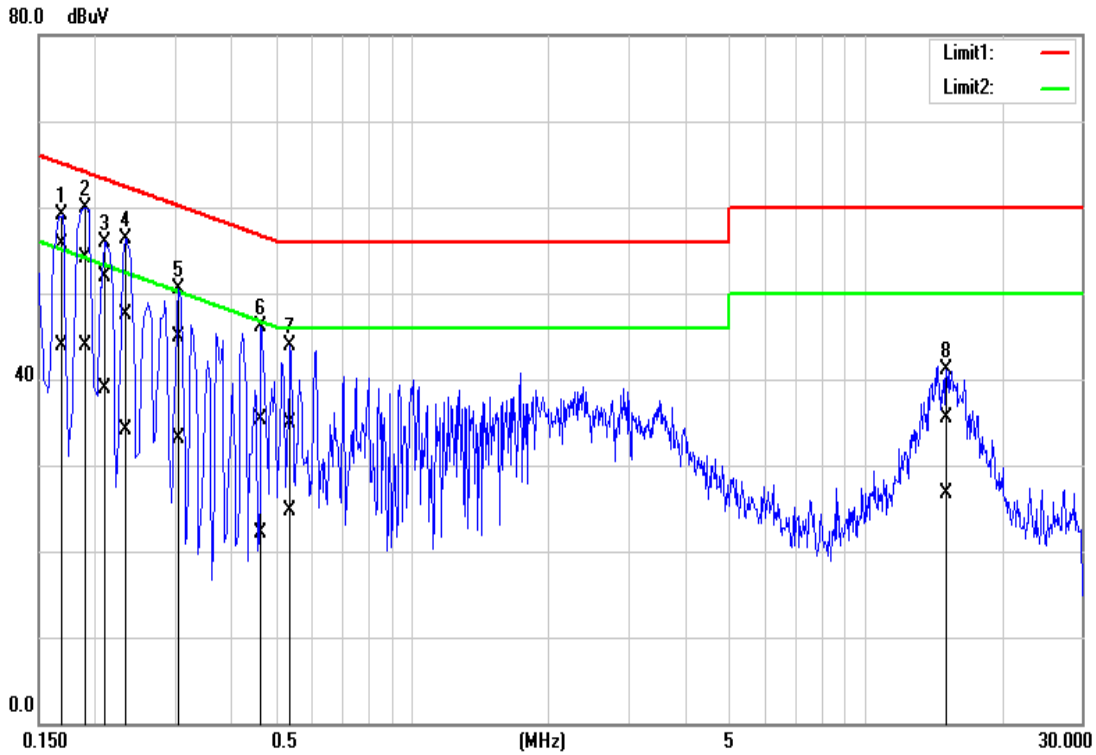

Conducted emissions (Line 2)

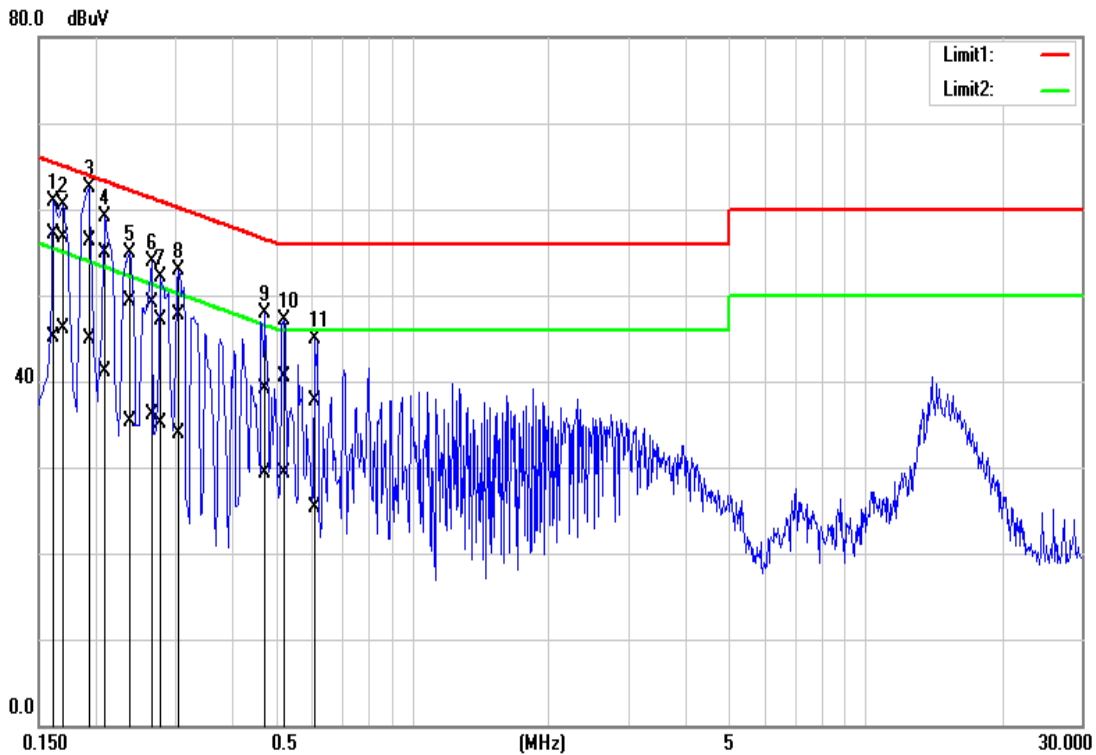

7.8 FREQUENCY STABILITY

LIMIT

According to §15.407(g) & RSS-247, manufacturers of U-NII devices are responsible for ensuring frequency stability such that an emission is maintained within the band of operation under all conditions of normal operation as specified in the operational description.

Test Configuration

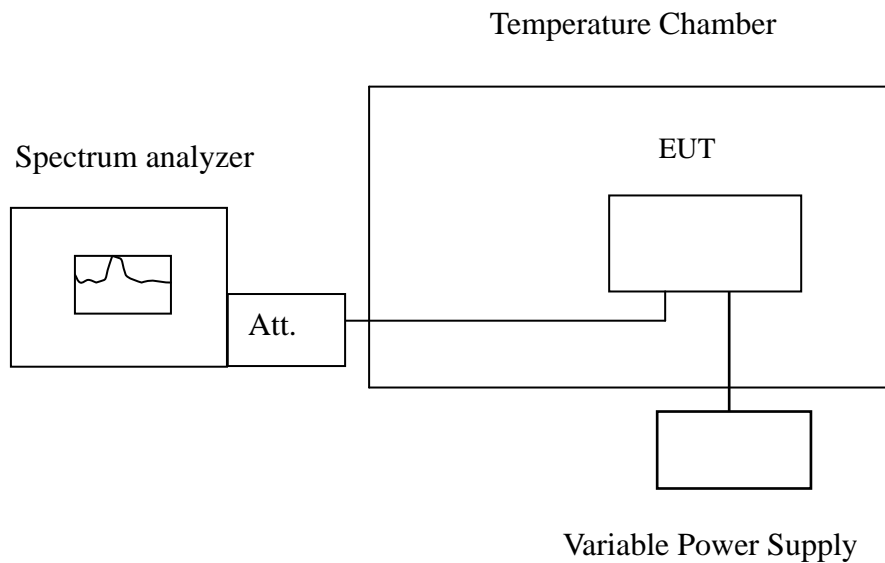

Remark: Measurement setup for testing on Antenna connector

TEST PROCEDURE

The equipment under test was connected to an external AC or DC power supply and input rated voltage. RF output was connected to a frequency counter or spectrum analyzer via feed through attenuators. The EUT was placed inside the temperature chamber. Set the spectrum analyzer RBW low enough to obtain the desired frequency resolution and measure EUT 20°C operating frequency as reference frequency. Turn EUT off and set the chamber temperature to -20°C. After the temperature stabilized for approximately 30 minutes recorded the frequency. Repeat step measure with 10°C increased per stage until the highest temperature of +50°C reached.

TEST RESULTS

No non-compliance noted.

Operating Frequency: 5280 MHz				
Environment Temperature (°C)	Voltage (V)	Measured Frequency (MHz)	Limit (20ppm)	Test Result
50	120	5180.001470	0.283783784	Pass
40	120	5179.994300	-1.1003861	Pass
30	120	5179.995700	-0.83011583	Pass
20	120	5179.999130	-0.167953668	Pass
10	120	5179.998700	-0.250965251	Pass
0	120	5179.998260	-0.335907336	Pass
-10	120	5179.999130	-0.167953668	Pass
-20	120	5179.997400	-0.501930502	Pass

Operating Frequency: 5280 MHz				
Environment Temperature (°C)	Voltage (V)	Measured Frequency (MHz)	Limit (20ppm)	Test Result
20	102	5179.999130	-0.167953668	Pass
	120	5179.999130	-0.167953668	Pass
	138	5179.999130	-0.167953668	Pass

7.9 DYNAMIC FREQUENCY SELECTION

TEST PROCEDURE

According to “KDB 905462 D02 v01r 02” and “KDB 905462 D03 v01r01”

LIMIT

According to §15.407 (h) and FCC 06-96 appendix “compliance measurement procedures for unlicensed-national information infrastructure devices operating in the 5250-5350 MHz and 5470-5725 MHz bands incorporating dynamic frequency selection”.

Remark: IC RSS-247 is closely harmonized with FCC Part 15 DFS rules.

Table 1: Applicability of DFS requirements prior to use of a channel

Requirement	Operational Mode		
	Master	Client (without radar detection)	Client(with radar detection)
Non-Occupancy Period	Yes	Not required	Yes
DFS Detection Threshold	Yes	Not required	Yes
Channel Availability Check Time	Yes	Not required	Not required
U-NII Detection Bandwidth	Yes	Not required	Yes

Table 2: Applicability of DFS requirements during normal operation

Requirement	Operational Mode	
	Master Device or Client with Radar Detection	Client Without Radar Detection
DFS Detection Threshold	Yes	Not required
Channel Closing Transmission Time	Yes	Yes
Channel Move Time	Yes	Yes
U-NII Detection Bandwidth	Yes	Not required

Table 3: Interference Threshold values, Master or Client incorporating In-Service

Maximum Transmit Power	Value (See Notes 1, 2, and 3)
EIRP ≥ 200 milliwatt	-64 dBm
EIRP < 200 milliwatt and power spectral density < 10 dBm/MHz	-62 dBm
EIRP < 200 milliwatt that do not meet the power spectral density requirement	-64 dBm

Note 1: This is the level at the input of the receiver assuming a 0 dBi receive antenna.

Note 2: Throughout these test procedures an additional 1 dB has been added to the amplitude of the test transmission waveforms to account for variations in measurement equipment. This will ensure that the test signal is at or above the detection threshold level to trigger a DFS response.

Note3: EIRP is based on the highest antenna gain. For MIMO devices refer to KDB Publication 662911 D01.

Table 4: DFS Response requirement values

Parameter	Value
Non-occupancy period	Minimum 30 minutes
Channel Availability Check Time	60 seconds
Channel Move Time	10 seconds See Note 1.
Channel Closing Transmission Time	200 milliseconds + an aggregate of 60 milliseconds over remaining 10 second period. See Notes 1 and 2.
U-NII Detection Bandwidth	Minimum 100% of the U-NII 99% transmission power bandwidth. See Note 3.

Note 1: Channel Move Time and the Channel Closing Transmission Time should be performed with Radar Type 0. The measurement timing begins at the end of the Radar Type 0 burst.

Note 2: The Channel Closing Transmission Time is comprised of 200 milliseconds starting at the beginning of the Channel Move Time plus any additional intermittent control signals required to facilitate a Channel move (an aggregate of 60 milliseconds) during the remainder of the 10 second period. The aggregate duration of control signals will not count quiet periods in between transmissions.

Note 3: During the U-NII Detection Bandwidth detection test, radar type 0 should be used. For each frequency step the minimum percentage of detection is 90 percent. Measurements are performed with no data traffic.

Table 5 – Short Pulse Radar Test Waveforms

Radar Type	Pulse Width (µsec)	PRI (µsec)	Number of Pulses	Minimum Percentage of Successful Detection	Minimum Number of Trials
0	1	1428	18	60%	30
1	1	Test A: 15 unique PRI values randomly selected from the list of 23 PRI values in Table 5a	$\text{Roundup} \left\{ \begin{matrix} \left(\frac{1}{360} \right) \cdot \\ \left(\frac{19 \cdot 10^6}{\text{PRI}_{\mu\text{sec}}} \right) \end{matrix} \right\}$	60%	30
		Test B: 15 unique PRI values randomly selected within the range of 518-3066 µsec, with a minimum increment of 1 µsec, excluding PRI values selected in Test A			
2	1-5	150-230	23-29	60%	30
3	6-10	200-500	16-18	60%	30
4	11-20	200-500	12-16	60%	30
Aggregate (Radar Types 1-4)				80%	120

Note 1: Short Pulse Radar Type 0 should be used for the detection bandwidth test, channel move time, and channel closing time tests.

Table 6 – Long Pulse Radar Test Signal

Radar Type	Pulse Width (µsec)	Chirp Width (MHz)	PRI (µsec)	Number of Pulses per Burst	Number of Bursts	Minimum Percentage of Successful Detection	Minimum Number of Trials
5	50-100	5-20	1000-2000	1-3	8-20	80%	30

Table 7 – Frequency Hopping Radar Test Signal

Radar Type	Pulse Width (µsec)	PRI (µsec)	Pulses per Hop	Hopping Rate (kHz)	Hopping Sequence Length (msec)	Minimum Percentage of Successful Detection	Minimum Number of Trials
6	1	333	9	0.333	300	70%	30

DESCRIPTION OF EUT

Overview Of EUT With Respect To §15.407 (H) Requirements

The firmware installed in the EUT during testing was:

Firmware Rev: 3.18.22

The EUT operates over the 5250-5350 MHz range as a Client Device that does not have radar detection capability.

The EUT uses one transmitter connected to two 50-ohm coaxial antenna ports via a diversity switch. Only one antenna port is connected to the test system since the EUT has one antenna only.

The Slave device associated with the EUT during these tests does not have radar detection capability.

WLAN traffic is generated by streaming the video file TestFile.mp2 “6 ½ Magic Hours” from the Master to the Slave in full motion video mode using the media player with the V2.61 Codec package.

The EUT utilizes the 802.11a architecture, with a nominal channel bandwidth of 20 MHz.

The rated output power of the Master unit is < 23dBm (EIRP). Therefore the required interference threshold level is -62 dBm. After correction for antenna gain and procedural adjustments, the required conducted threshold at the antenna port is $-62 + 5 = -57$ dBm.

The calibrated conducted DFS Detection Threshold level is set to -57 dBm. The tested level is lower than the required level hence it provides margin to the limit.

Manufacturer’s Statement Regarding Uniform Channel Spreading

The end product implements an automatic channel selection feature at startup such that operation commences on channels distributed across the entire set of allowed 5GHz channels. This feature will ensure uniform spreading is achieved while avoiding non-allowed channels due to prior radar events.

TEST AND MEASUREMENT SYSTEM

System Overview

The measurement system is based on a conducted test method.

The short pulse and long pulse signal generating system utilizes the NTIA software. The Vector Signal Generator has been validated by the NTIA. The hopping signal generating system utilizes the CCS simulated hopping method and system, which has been validated by the DoD, FCC and NTIA. The software selects waveform parameters from within the bounds of the signal type on a random basis using uniform distribution.

The short pulse types 2, 3 and 4, and the long pulse type 5 parameters are randomized at run-time.

The hopping type 6 pulse parameters are fixed while the hopping sequence is based on the August 2005 NTIA Hopping Frequency List. The initial starting point randomized at run-time and each subsequent starting point is incremented by 475. Each frequency in the 100-length segment is compared to the boundaries of the EUT Detection Bandwidth and the software creates a hopping burst pattern in accordance with Section 7.4.1.3 Method #2 Simulated Frequency Hopping Radar Waveform Generating Subsystem of FCC 06-96 APPENDIX. The frequency of the signal generator is incremented in 1 MHz steps from FL to FH for each successive trial. This incremental sequence is repeated as required to generate a minimum of 30 total trials and to maintain a uniform frequency distribution over the entire Detection Bandwidth.

The signal monitoring equipment consists of a spectrum analyzer set to display 8001 bins on the horizontal axis. The time-domain resolution is 2 msec / bin with a 16 second sweep time, meeting the 10 second short pulse reporting criteria. The aggregate ON time is calculated by multiplying the number of bins above a threshold during a particular observation period by the dwell time per bin, with the analyzer set to peak detection and max hold. The time-domain resolution is 3 msec / bin with a 24 second sweep time, meeting the 22 second long pulse reporting criteria and allowing a minimum of 10 seconds after the end of the long pulse waveform.

Should multiple RF ports be utilized for the Master and/or Slave devices (for example, for diversity or MIMO implementations), 50 ohm termination would be removed from the splitter so that connection can be established between splitter and the Master and/or Slave devices.

Conducted Method System Block Diagram

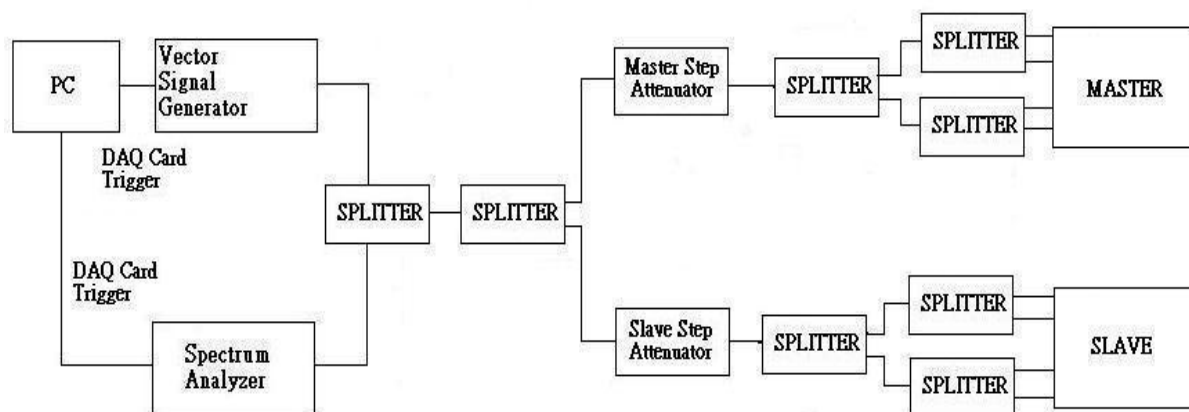

System Calibration

Connect the spectrum analyzer to the test system in place of the master device. Set the signal generator to CW mode. Adjust the amplitude of the signal generator to yield a measured level of -62 dBm on the spectrum analyzer.

Without changing any of the instrument settings, reconnect the spectrum analyzer to the Common port of the Spectrum Analyzer Combiner/Divider and connect a 50 ohm load to the Master Device port of the test system.

Measure the amplitude and calculate the difference from -62 dBm. Adjust the Reference Level Offset of the spectrum analyzer to this difference. Confirm that the signal is displayed at -62 dBm. Readjust the RBW and VBW to 3 MHz, set the span to 10 MHz, and confirm that the signal is still displayed at -62 dBm.

The spectrum analyzer displays the level of the signal generator as received at the antenna ports of the Master Device. The interference detection threshold may be varied from the calibrated value of -62 dBm and the spectrum analyzer will still indicate the level as received by the Master Device.

Set the signal generator to produce a radar waveform, trigger a burst manually and measure the level on the spectrum analyzer. Readjust the amplitude of the signal generator as required so that the peak level of the waveform is at a displayed level equal to the required or desired interference detection threshold. Separate signal generator amplitude settings are determined as required for each radar type.

Adjustment Of Displayed Traffic Level

Establish a link between the Master and Slave, adjusting the Link Step Attenuator as needed to provide a suitable received level at the Master and Slave devices. Stream the video test file to generate WLAN traffic. Confirm that the WLAN traffic level, as displayed on the spectrum analyzer, is at lower amplitude than the radar detection threshold. Confirm that the displayed traffic is from the Master Device. For Master Device testing confirm that the displayed traffic does not include Slave Device traffic. For Slave Device testing confirm that the displayed traffic does not include Master Device traffic.

If a different setting of the Master Step Attenuator is required to meet the above conditions, perform a new System Calibration for the new Master Step Attenuator setting.

Test Setup

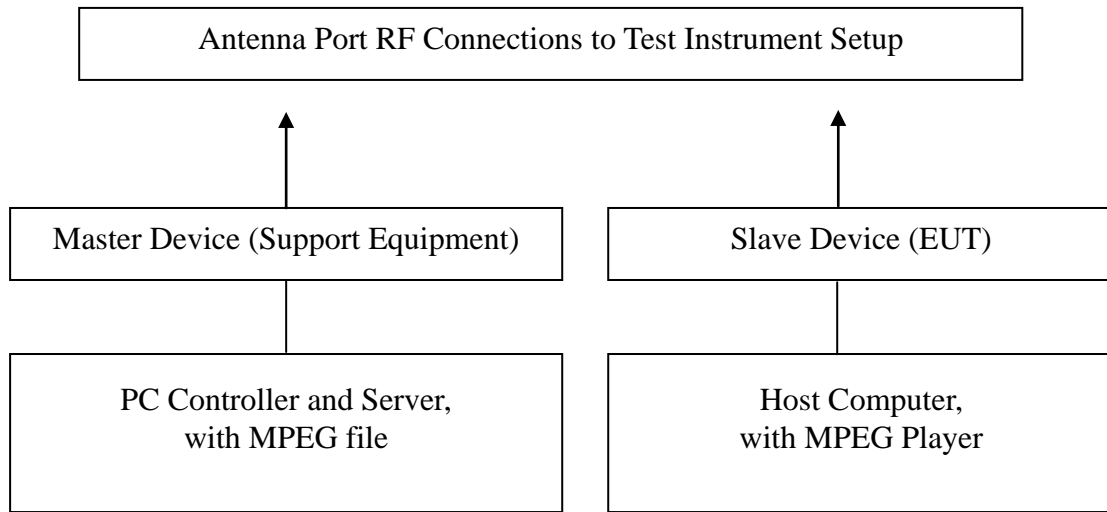

TEST RESULTS

No non-compliance noted

PLOT OF WLAN TRAFFIC FROM SLAVE

IEEE 802.11n HT 20 MHz mode / 5320MHz

Noise Floor

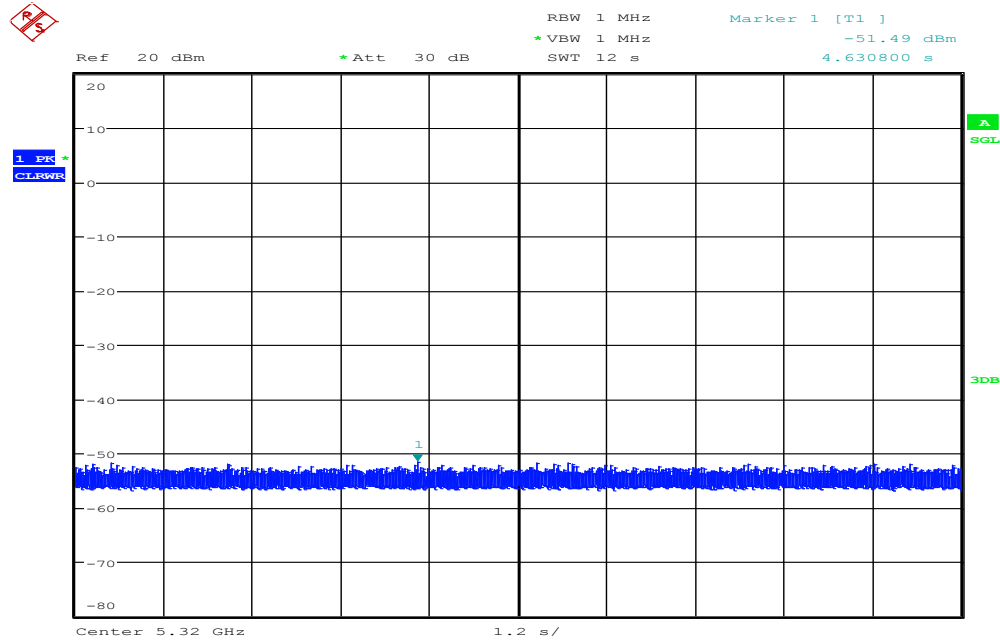

Date: 12.APR.2016 17:36:17

Master Level

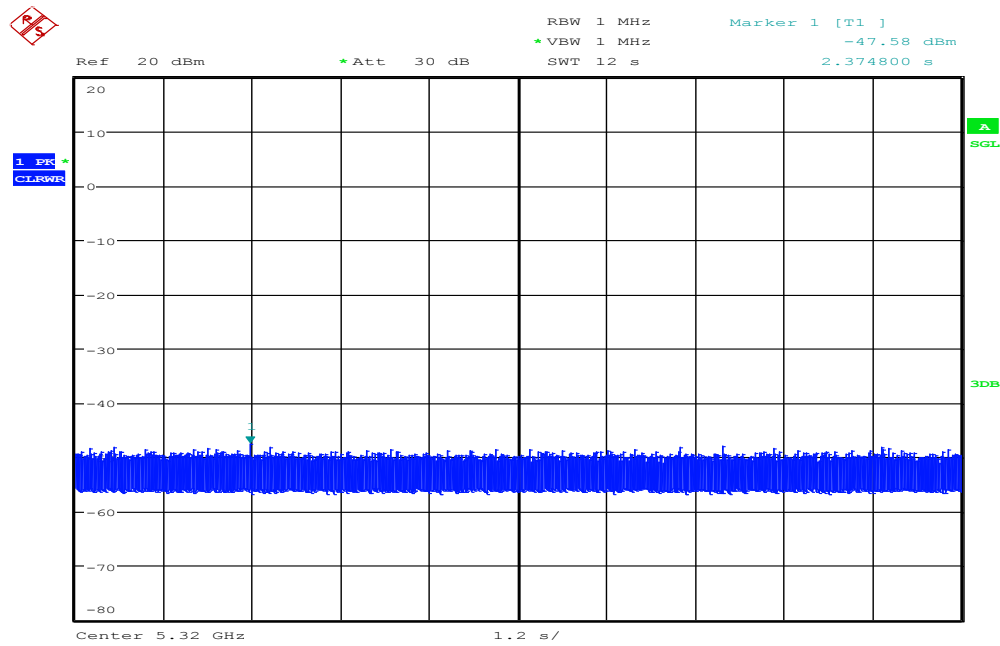

Date: 12.APR.2016 17:52:06

Slave Level

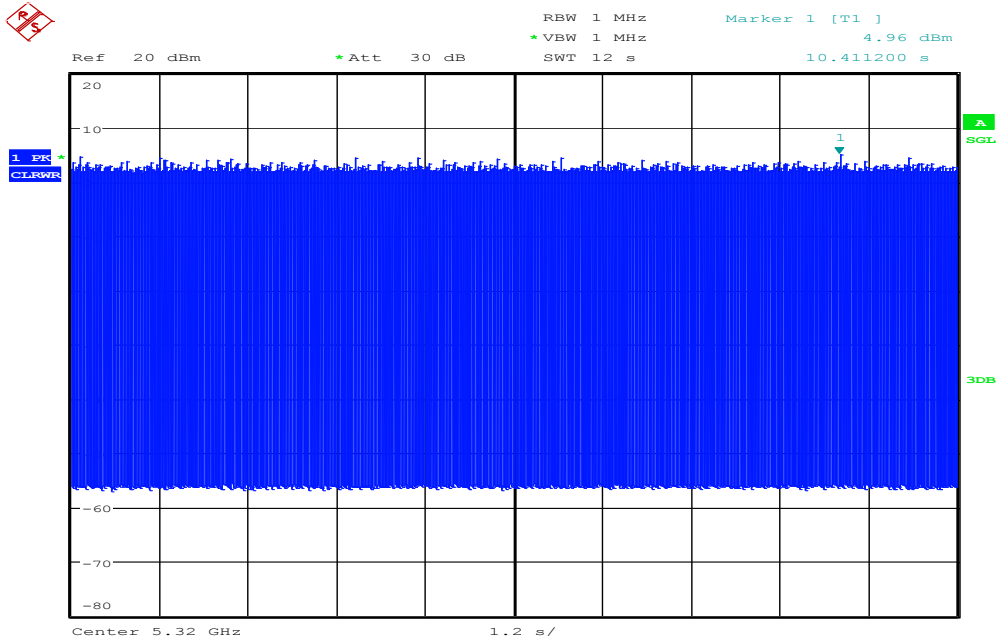

Date: 12.APR.2016 17:40:19

IEEE 802.11n HT 20 MHz mode / 5500MHz

Noise Floor

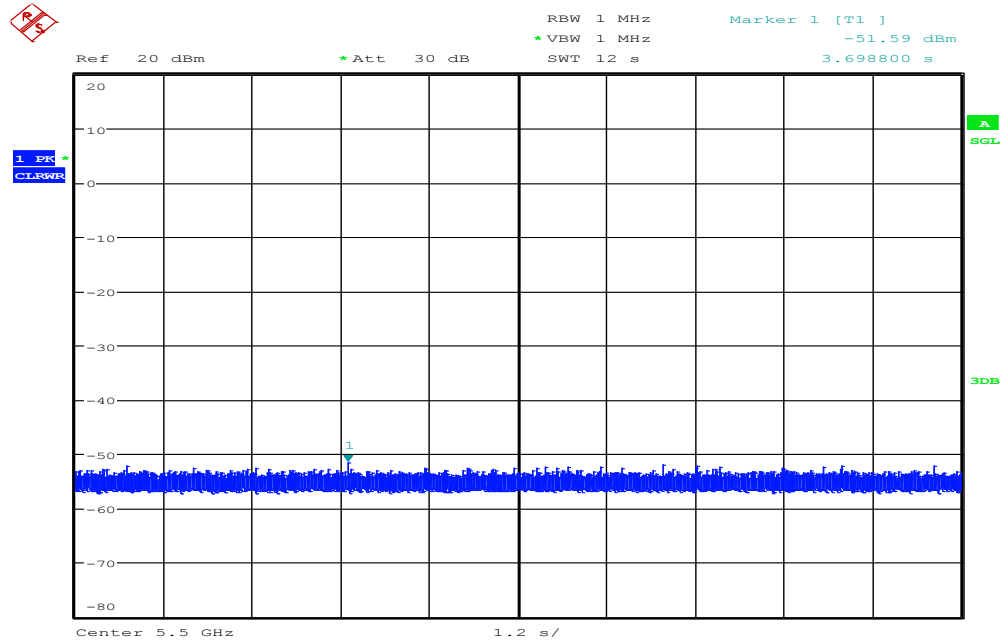

Date: 12.APR.2016 18:18:21

Master Level

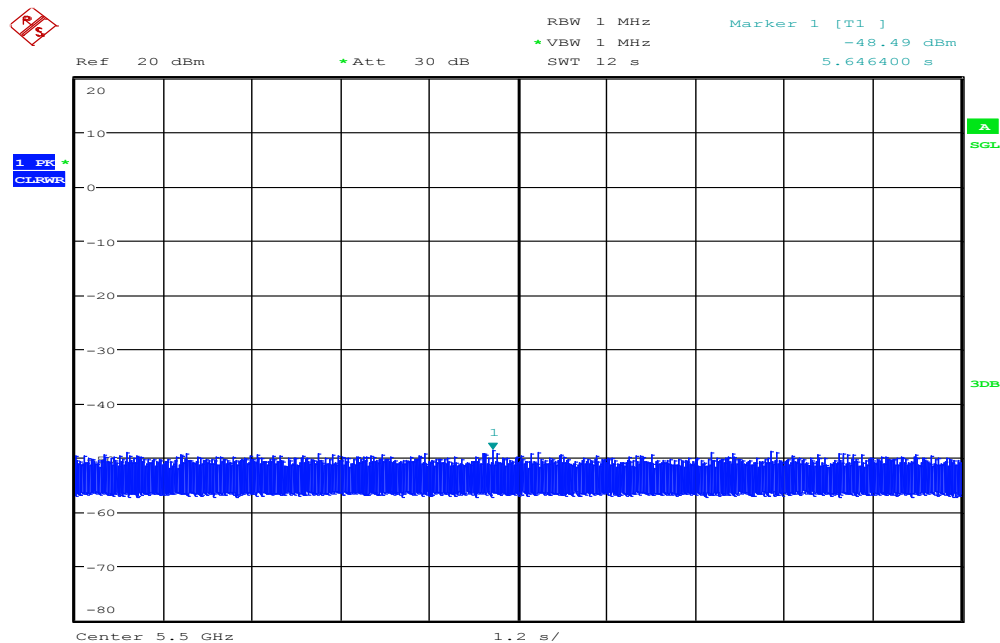

Date: 12.APR.2016 18:17:40

Slave Level

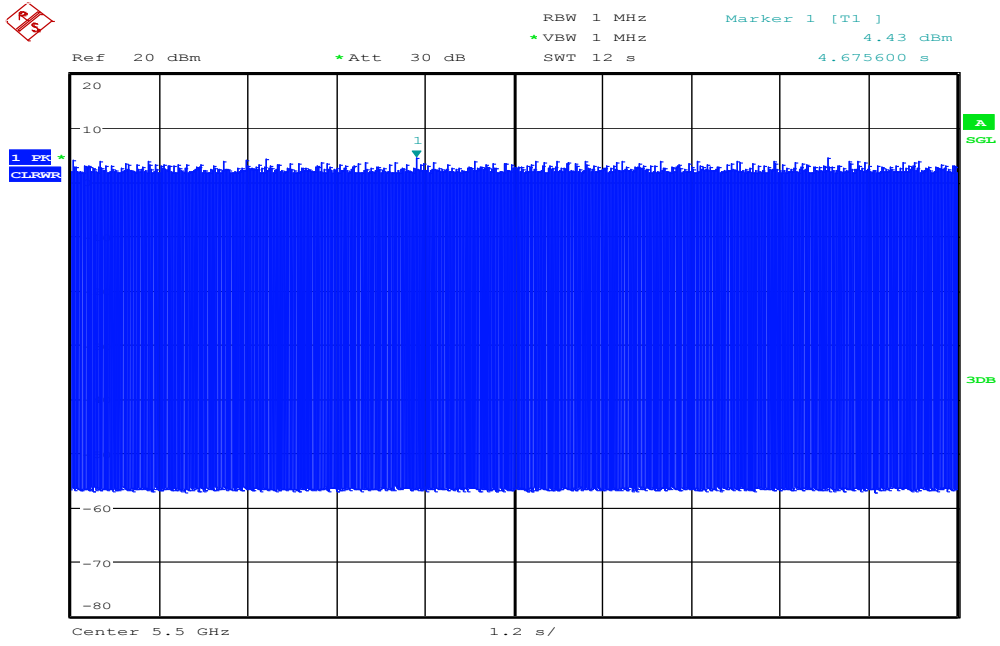

Date: 12.APR.2016 18:16:29

IEEE 802.11n HT 40 MHz mode / 5310MHz

Noise Floor

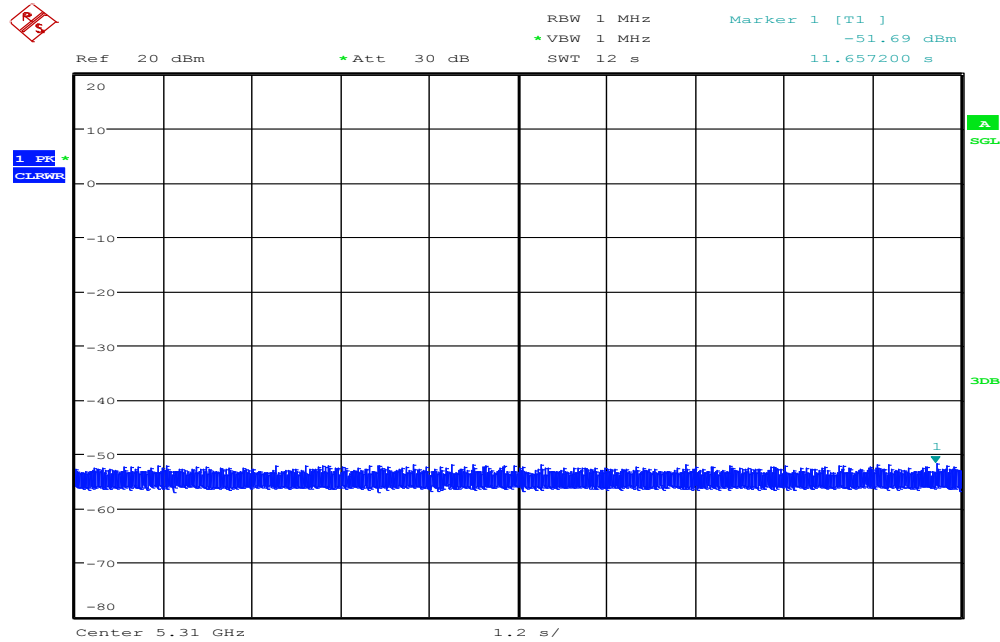

Date: 12.APR.2016 19:25:20

Master Level

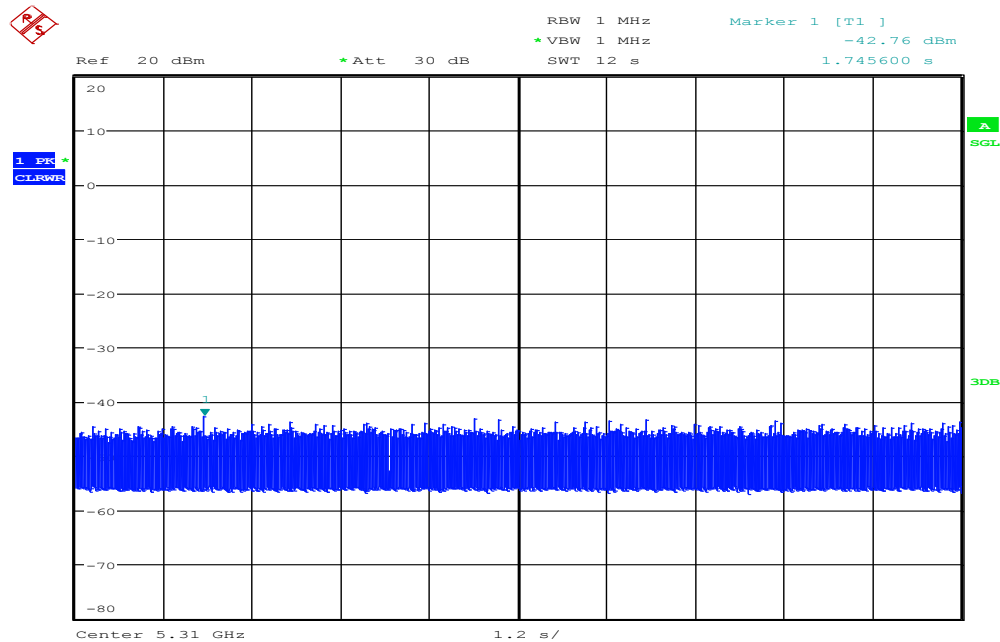

Date: 12.APR.2016 20:08:09

Slave Level

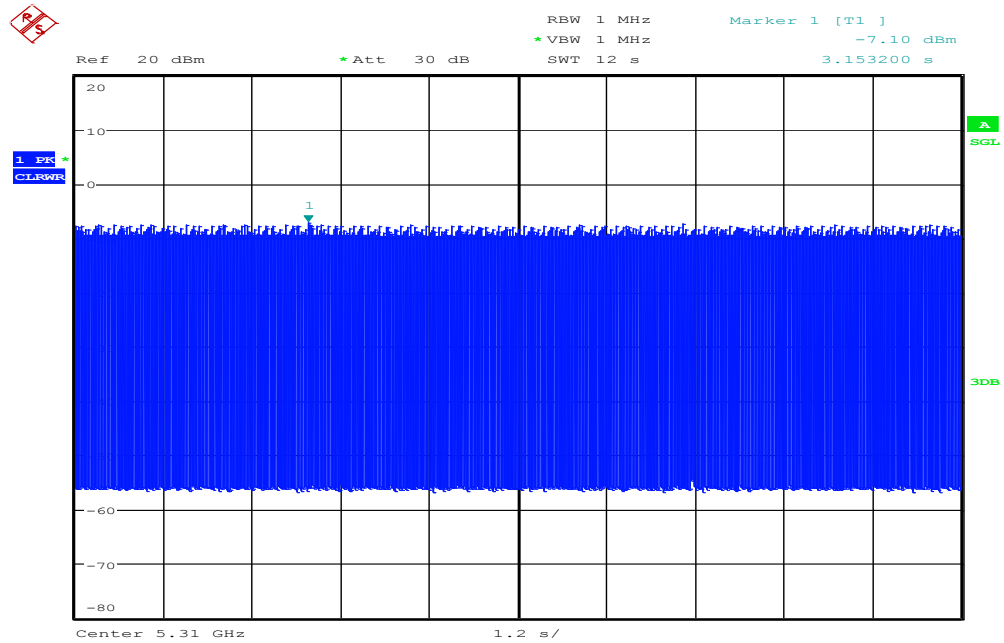

Date: 12.APR.2016 19:22:44

IEEE 802.11n HT 40 MHz mode / 5510MHz

Noise Floor

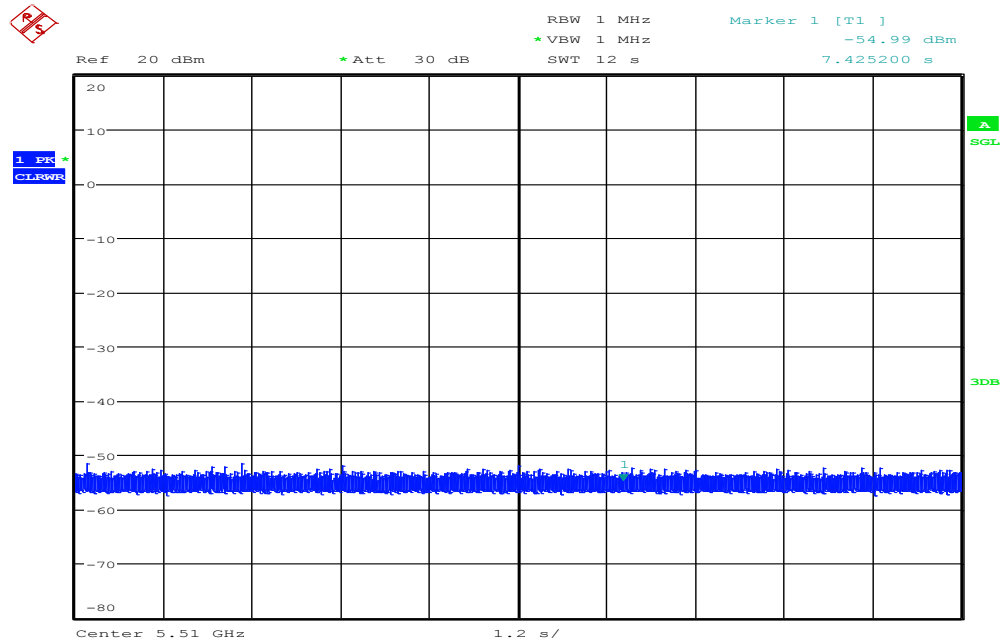

Date: 12.APR.2016 19:49:09

Master Level

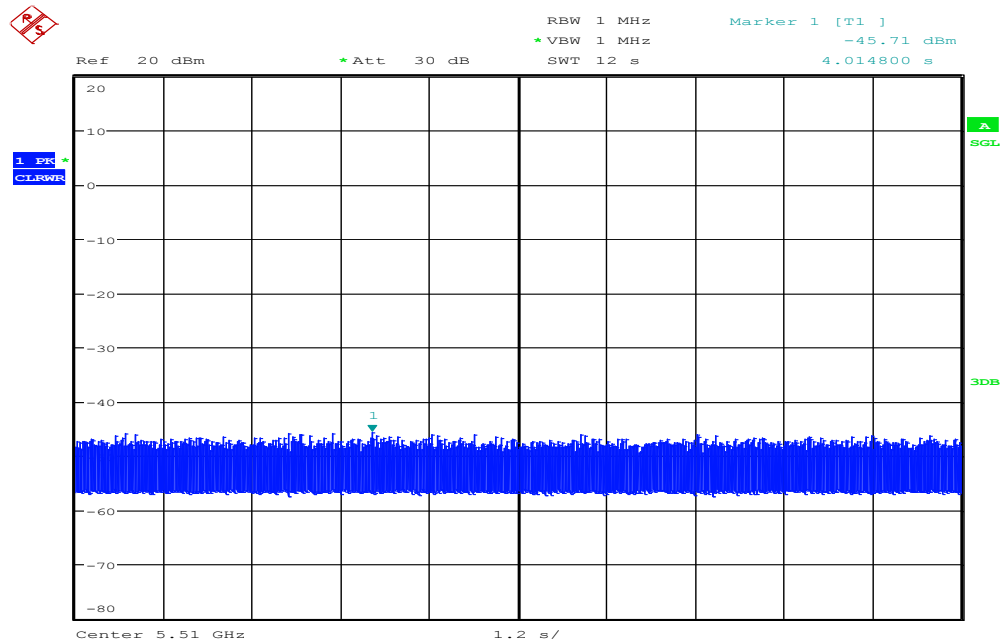

Date: 12.APR.2016 19:50:00

Slave Level

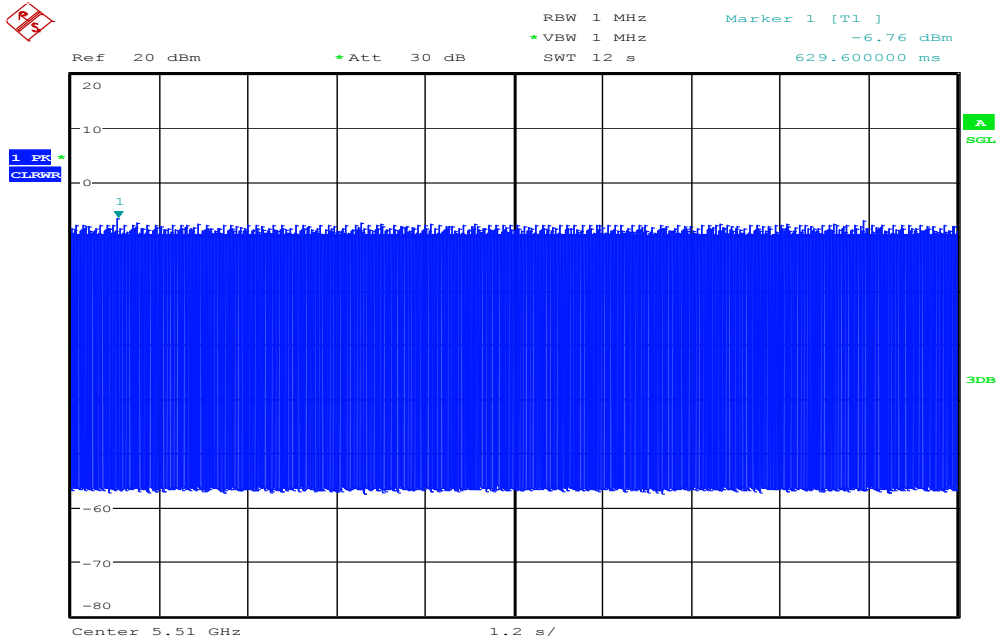

Date: 12.APR.2016 19:46:01

TEST CHANNEL AND METHOD

All tests were performed at a channel center frequency of 5530 MHz utilizing a conducted test method.

CHANNEL MOVE TIME AND CHANNEL CLOSING TRANSMISSION TIME

GENERAL REPORTING NOTES

The reference marker is set at the end of last radar pulse.

The delta marker is set at the end of the last WLAN transmission following the radar pulse. This delta is the channel move time.

The aggregate channel closing transmission time is calculated as follows:

Aggregate Transmission Time =

(Number of analyzer bins showing transmission) * (dwell time per bin)

The observation period over which the aggregate time is calculated

Begins at (Reference Marker + 200 msec) and

Ends no earlier than (Reference Marker + 10 sec).

IEEE 802.11n HT 20 MHz mode / 5320MHz

Type 1 Channel Move Time Results

No non-compliance noted.

Channel Move Time (s)	Limit (s)
-0.2	10

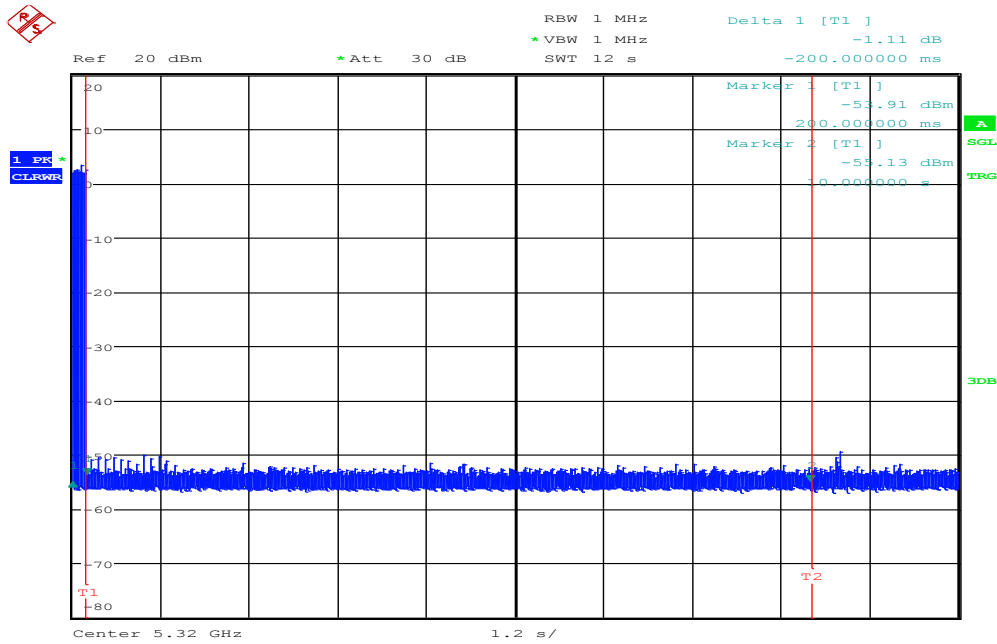

Date: 12.APR.2016 17:55:32

Type 1 Channel Closing Transmission Time Results

No non-compliance noted.

Aggregate Transmission Time (ms)	Limit (ms)	Margin (ms)
0	60	-60

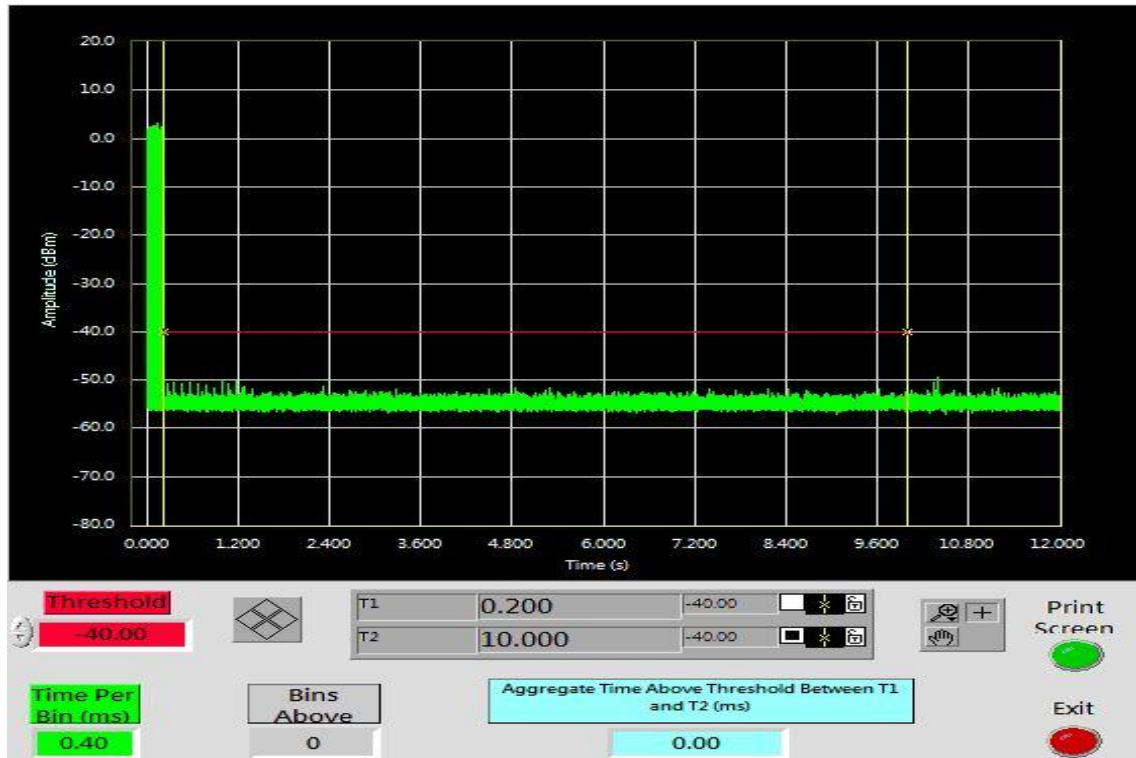

IEEE 802.11n HT 20 MHz mode / 5500MHz

Type 1 Channel Move Time Results

No non-compliance noted.

Channel Move Time (s)	Limit (s)
-0.2	10

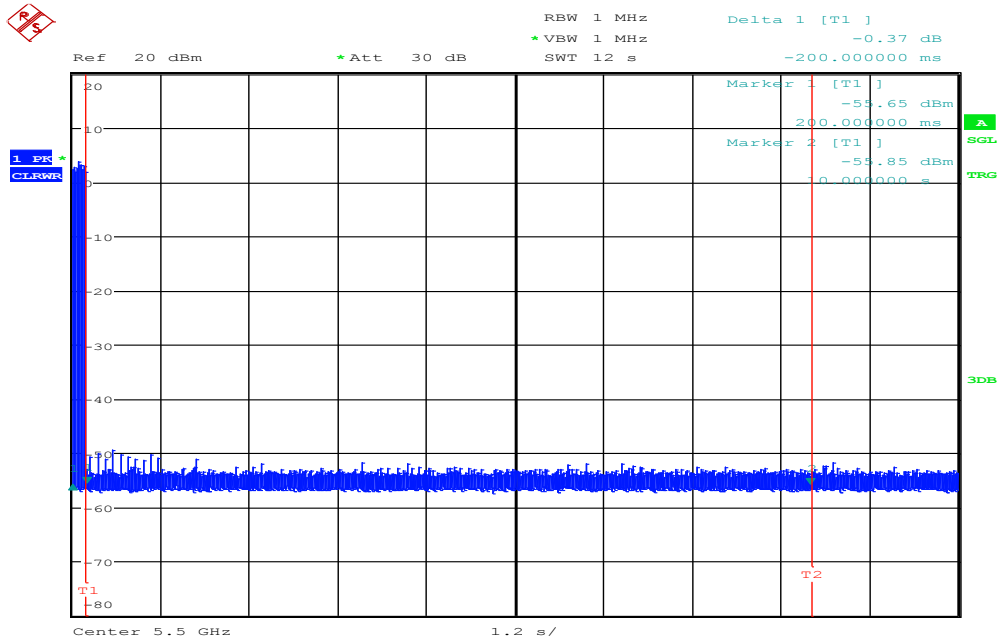

Date: 12.APR.2016 18:26:54

Type 1 Channel Closing Transmission Time Results

No non-compliance noted.

Aggregate Transmission Time (ms)	Limit (ms)	Margin (ms)
0	60	-60

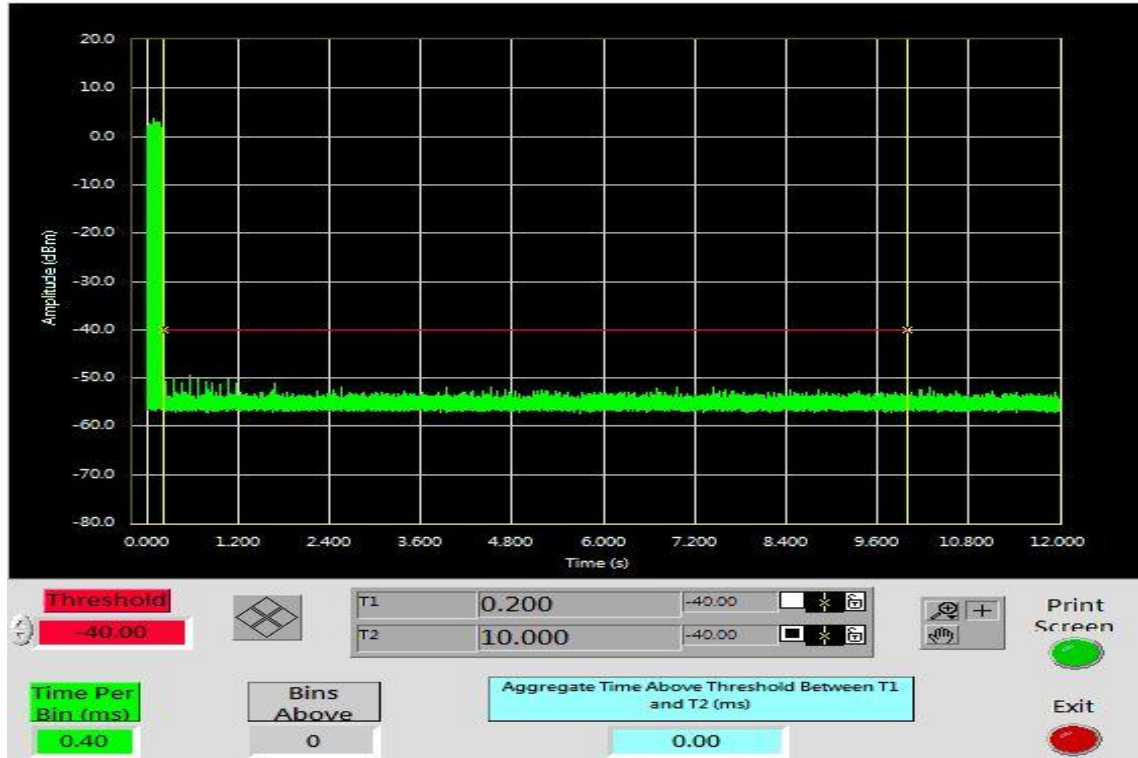

IEEE 802.11n HT 40 MHz mode / 5310MHz

Type 1 Channel Move Time Results

No non-compliance noted.

Channel Move Time (s)	Limit (s)
-0.2	10

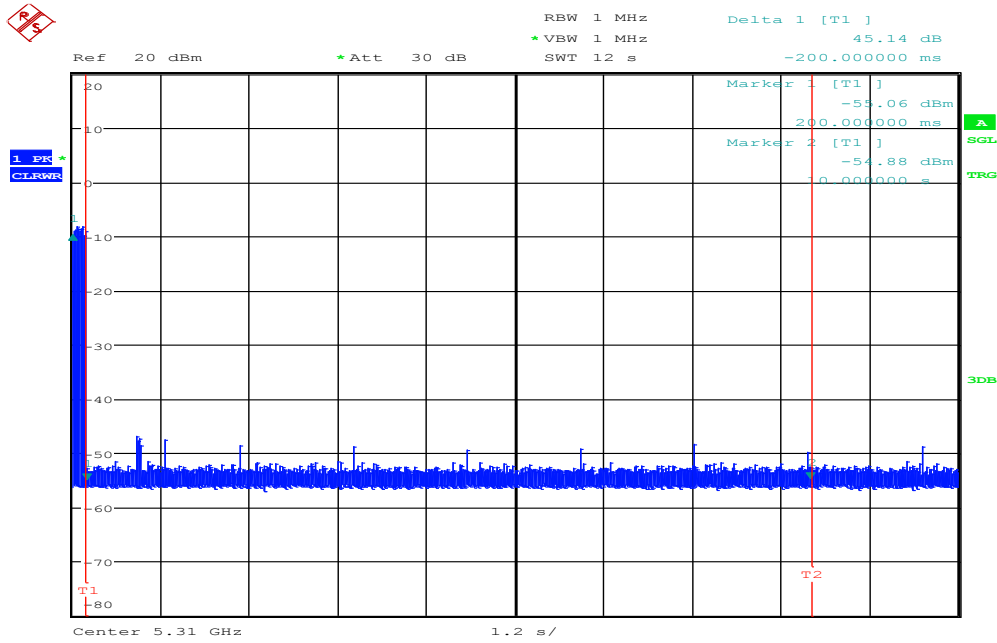

Date: 12.APR.2016 19:33:01

Type 1 Channel Closing Transmission Time Results

No non-compliance noted.

Aggregate Transmission Time (ms)	Limit (ms)	Margin (ms)
0	60	-60

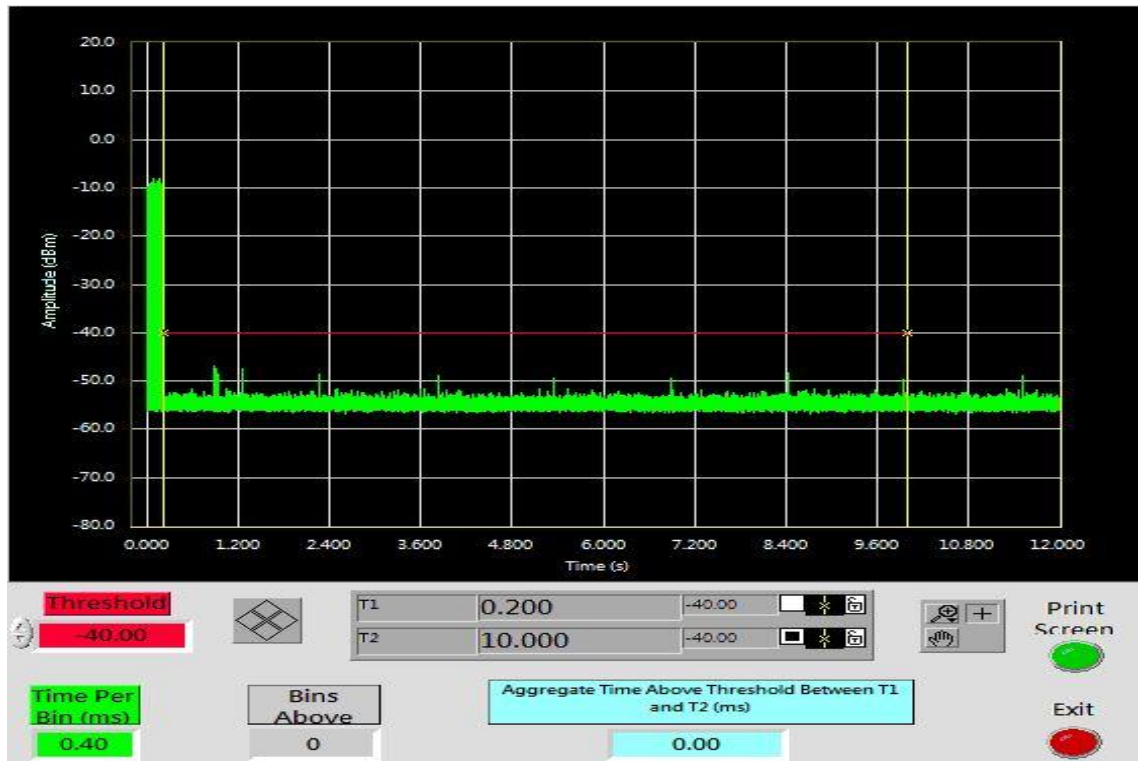

IEEE 802.11n HT 40 MHz mode / 5510MHz

Type 1 Channel Move Time Results

No non-compliance noted.

Channel Move Time (s)	Limit (s)
-0.2	10

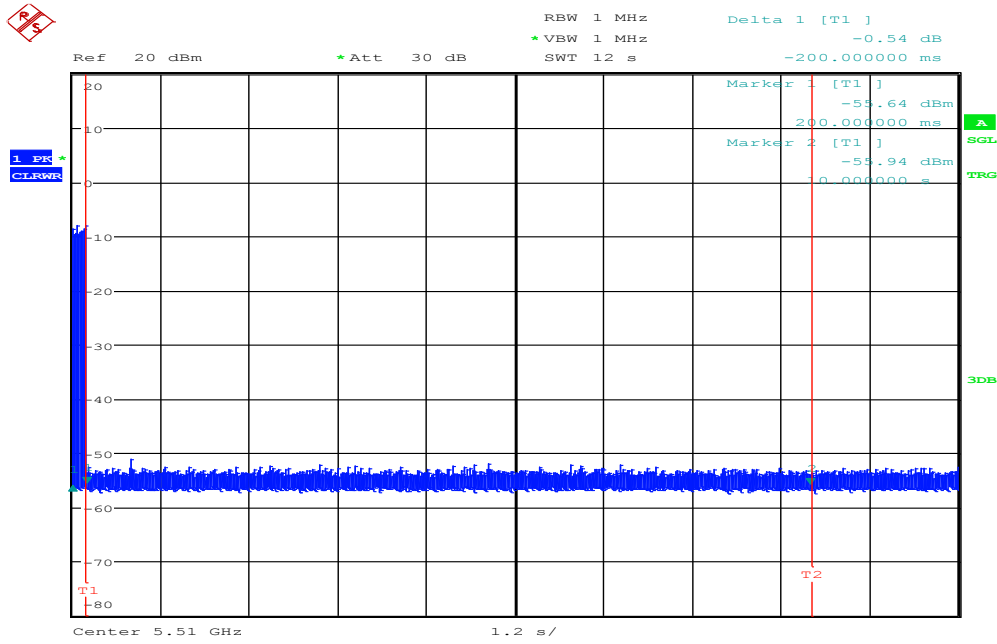

Date: 12.APR.2016 19:53:42

Type 1 Channel Closing Transmission Time Results

No non-compliance noted.

Aggregate Transmission Time (ms)	Limit (ms)	Margin (ms)
0	60	-60

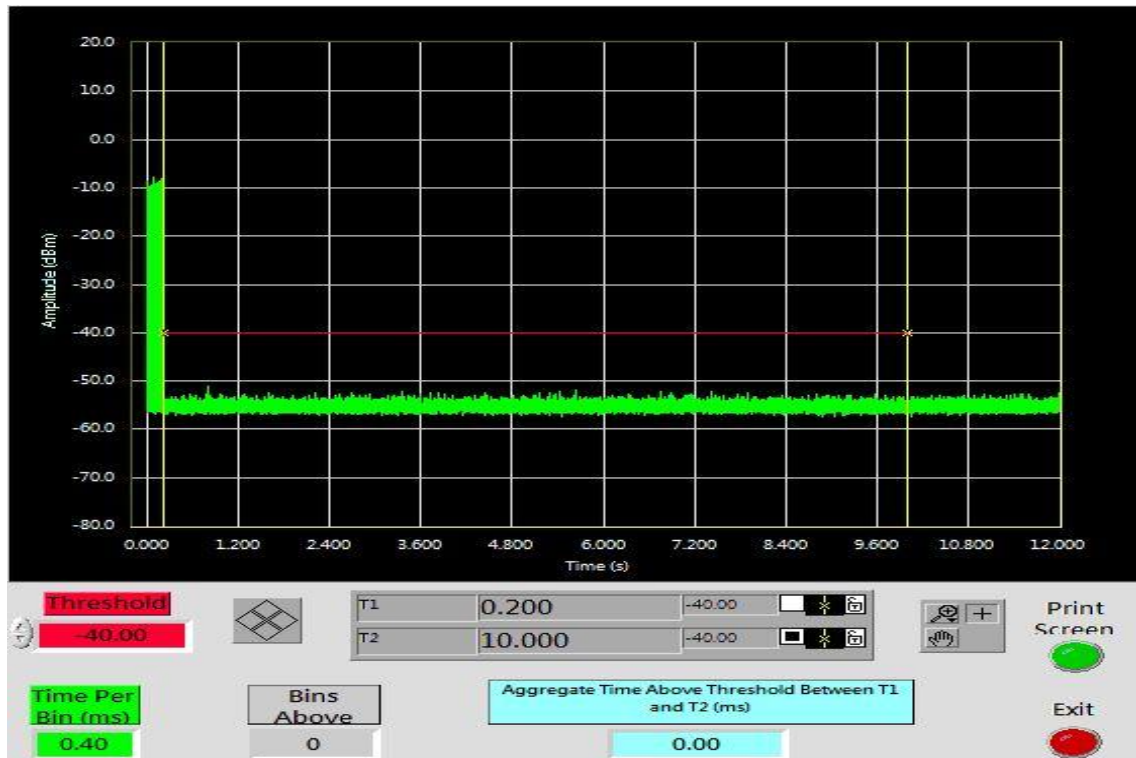

NON-OCCUPANCY PERIOD

IEEE 802.11n HT 20 MHz mode / 5320MHz

Type 1 Non-Occupancy Period Test Results

No non-compliance noted.

No EUT transmissions were observed on the test channel during the 30 minute observation time.

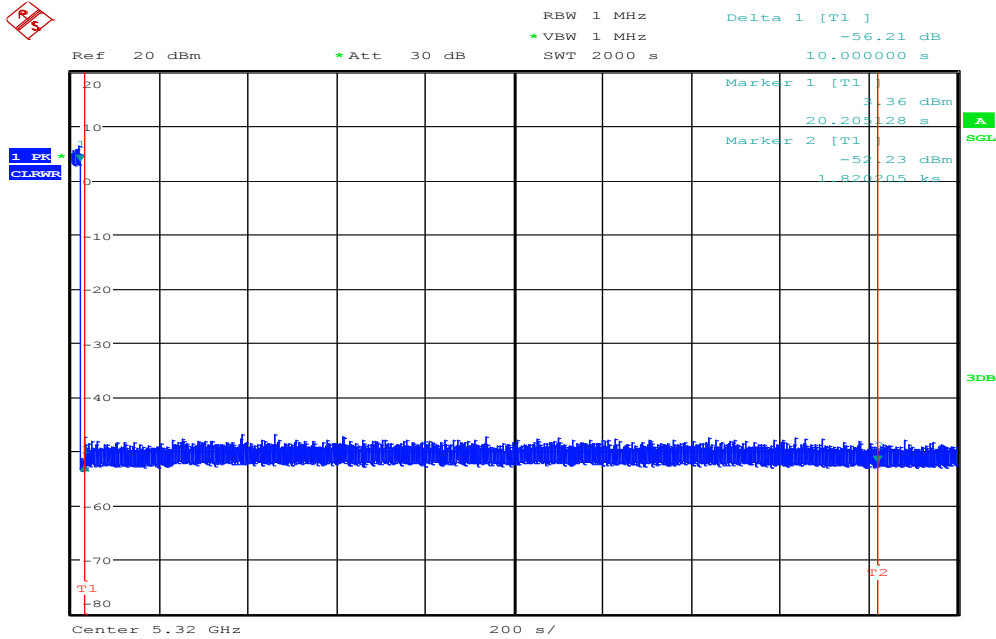

Date: 12.APR.2016 21:45:04

IEEE 802.11n HT 20 MHz mode / 5500MHz

Type 1 Non-Occupancy Period Test Results

No non-compliance noted.

No EUT transmissions were observed on the test channel during the 30 minute observation time.

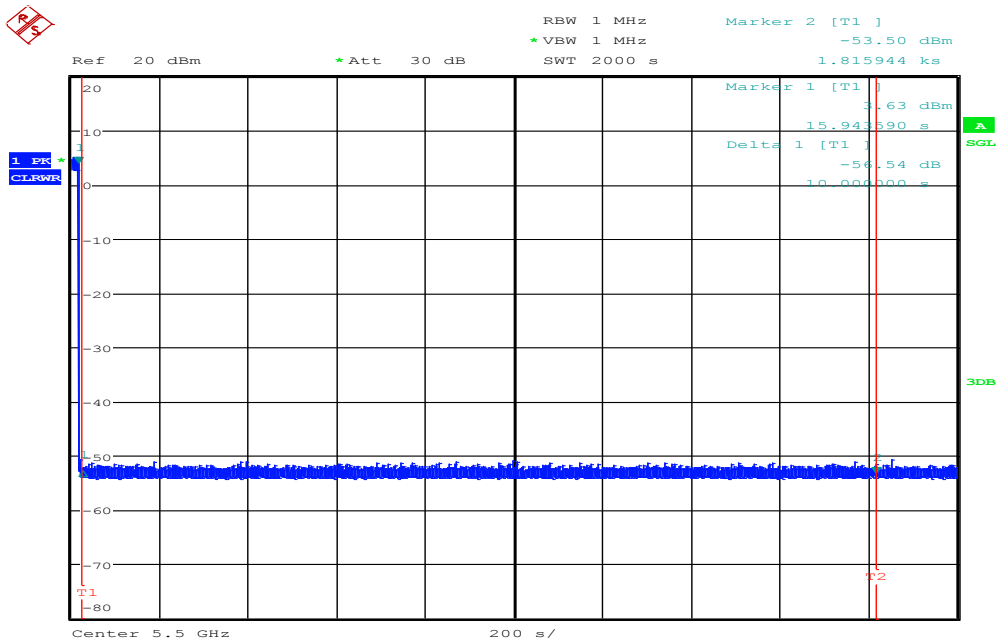

Date: 12.APR.2016 23:03:42

IEEE 802.11n HT 40 MHz mode / 5310MHz

Type 1 Non-Occupancy Period Test Results

No non-compliance noted.

No EUT transmissions were observed on the test channel during the 30 minute observation time.

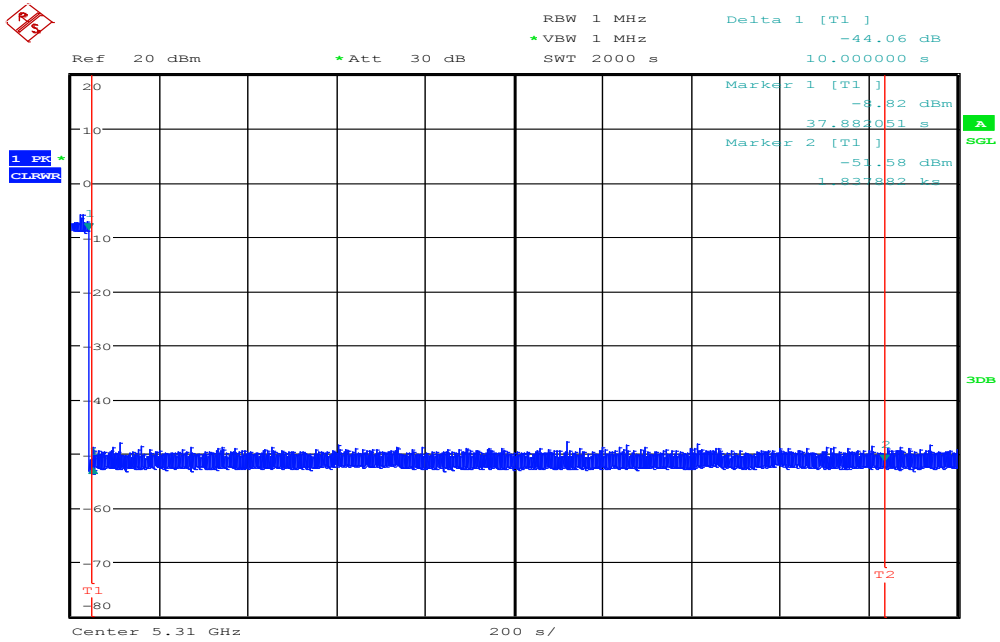

Date: 12.APR.2016 21:08:12

IEEE 802.11n HT 40 MHz mode / 5510MHz

Type 1 Non-Occupancy Period Test Results

No non-compliance noted.

No EUT transmissions were observed on the test channel during the 30 minute observation time.

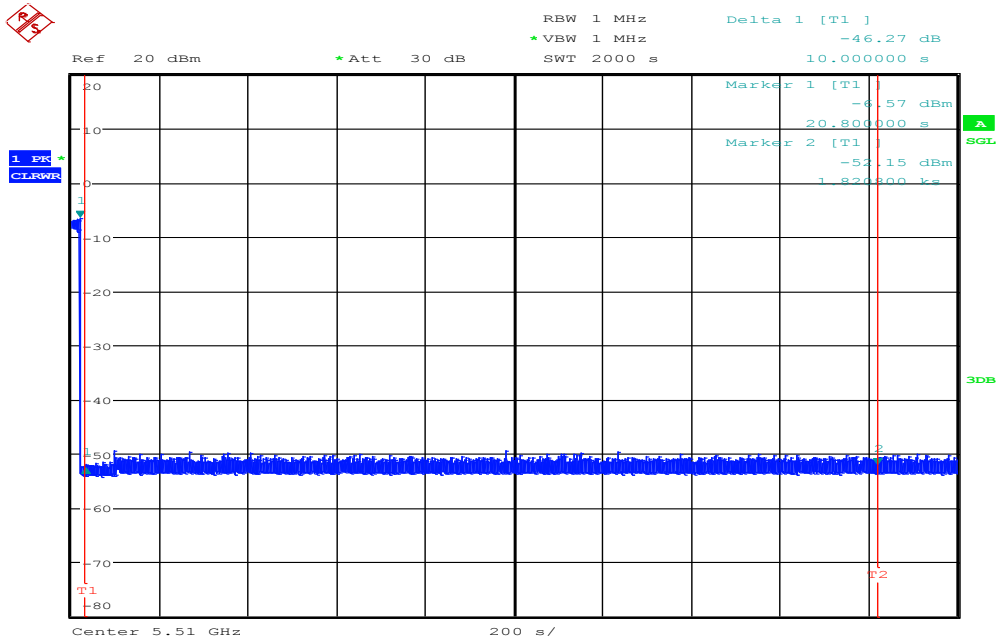

Date: 12.APR.2016 23:52:08