

FCC Test Report

FCC ID : HLZA21001
Equipment : Tablet PC
Marketing name : ENDURO Urban T3 EUT310A-11A
(Refer to item 1.1.1 for more details)
Model No. : A21001
Brand Name : acer
Applicant : Acer Incorporated
Address : 9F, 88, Sec. 1, Xintai 5th Rd., New Taipei City
22181, Taiwan (R.O.C)
Standard : 47 CFR FCC Part 15.247
Received Date : Dec. 03, 2021
Tested Date : Dec. 06 ~ Dec. 21, 2021

We, International Certification Corporation, would like to declare that the tested sample has been evaluated and in compliance with the requirement of the above standards. The test results contained in this report refer exclusively to the product. It may be duplicated completely for legal use with the approval of the applicant. It shall not be reproduced except in full without the written approval of our laboratory.

Reviewed by:

Approved by:



Along Chen / Assistant Manager



Gary Chang / Manager



Table of Contents

1	GENERAL DESCRIPTION	5
1.1	Information.....	5
1.2	Local Support Equipment List	9
1.3	Test Setup Chart	9
1.4	The Equipment List	10
1.5	Test Standards	11
1.6	Reference Guidance	11
1.7	Deviation from Test Standard and Measurement Procedure.....	11
1.8	Measurement Uncertainty	11
2	TEST CONFIGURATION.....	12
2.1	Testing Facility	12
2.2	The Worst Test Modes and Channel Details	12
3	TRANSMITTER TEST RESULTS	13
3.1	Conducted Emissions.....	13
3.2	6dB and Occupied Bandwidth.....	16
3.3	RF Output Power.....	22
3.4	Power Spectral Density	25
3.5	Unwanted Emissions into Restricted Frequency Bands	31
3.6	Emissions in Non-Restricted Frequency Bands.....	59
4	TEST LABORATORY INFORMATION	64

Release Record

Report No.	Version	Description	Issued Date
FR1D0301AC	Rev. 01	Initial issue	Jan. 03, 2022

Summary of Test Results

FCC Rules	Test Items	Measured	Result
15.207	Conducted Emissions	[dBuV]: 0.627MHz 39.84 (Margin -6.16dB) - AV	Pass
15.247(d) 15.209	Radiated Emissions	[dBuV/m at 3m]: 4924.00MHz 50.88 (Margin -3.12dB) - AV	Pass
15.247(b)(3)	Maximum Output Power	Max Power [dBm]: 20.95	Pass
15.247(a)(2)	6dB Bandwidth	Meet the requirement of limit	Pass
15.247(e)	Power Spectral Density	Meet the requirement of limit	Pass
15.203	Antenna Requirement	Meet the requirement of limit	Pass

Declaration of Conformity:

The test results with all measurement uncertainty excluded are presented in accordance with the regulation limits or requirements declared by manufacturers.

Comments and Explanations:

The declared of product specification for EUT presented in the report are provided by the manufacturer, and the manufacturer takes all the responsibilities for the accuracy of product specification.

1 General Description

1.1 Information

1.1.1 Product Details

The following models are provided to this EUT.

Brand Name	Model Name	Marketing name	Description
acer	A21001	ENDURO T1 ET110A-11A	With shockproof housing (plastic housing, without any metal composition)
		ENDURO Urban T3 EUT310A-11A	Without shockproof housing
<ul style="list-style-type: none"> ✦ All models are electrically identical, different model names are for marketing purpose. ✦ The above marketings, marketing ENDURO Urban T3 EUT310A-11A was selected as a representative one for the final test and only its data was recorded in this report. 			

1.1.2 Specification of the Equipment under Test (EUT)

RF General Information					
Frequency Range (MHz)	IEEE Std. 802.11	Ch. Freq. (MHz)	Channel Number	Transmit Chains (N _{TX})	Data Rate / MCS
2400-2483.5	b	2412-2462	1-11 [11]	1	1-11 Mbps
2400-2483.5	g	2412-2462	1-11 [11]	1	6-54 Mbps
2400-2483.5	n (HT20)	2412-2462	1-11 [11]	1	MCS 0-7
2400-2483.5	n (HT40)	2422-2452	3-9 [7]	1	MCS 0-7
<p>Note 1: RF output power specifies that Maximum Peak Conducted Output Power. Note 2: 802.11b uses a combination of DSSS-DBPSK, DQPSK, CCK modulation. Note 3: 802.11g/n uses a combination of OFDM-BPSK, QPSK, 16QAM, 64QAM modulation.</p>					

1.1.3 Antenna Details

Ant. No.	Brand	Model	Type	Connector	Gain (dBi)
1	cxytech	Z16	PIFA	N/A	5.46

1.1.4 Power Supply Type of Equipment under Test (EUT)

Power Supply Type	5Vdc from adapter 3.8V dc from battery
-------------------	---

1.1.5 Accessories

Accessories		
No.	Equipment	Description
1	Adapter	Brand: TIANYIN Model: TPA-23A050200UU01 Power Rating: I/P: 100-240Vac, 50/60Hz, 0.3A O/P: 5Vdc=2.0A
2	Battery	Brand: ZHUHAI GREAT POWER ENERGY CO., LTD. Model: 289392 Rated Capacity: 5900mAh/22.42Wh Topical Capacity: 6000mAh/22.8Wh Nominal Voltage: 3.8V Limited Charge Voltage: 4.35V
3	USB cable	Brand: SHENZHEN BAISITAI COMPUTER Model: USB AM TO Type-C Line: 1m shielded without core

1.1.6 Channel List

Frequency band (MHz)		2400~2483.5	
802.11 b / g / n HT20		802.11n HT40	
Channel	Frequency(MHz)	Channel	Frequency(MHz)
1	2412	3	2422
2	2417	4	2427
3	2422	5	2432
4	2427	6	2437
5	2432	7	2442
6	2437	8	2447
7	2442	9	2452
8	2447	---	---
9	2452	---	---
10	2457	---	---
11	2462	---	---

1.1.7 Test Tool and Duty Cycle

Test Tool	EngineerMode, Version: v4.4.107		
Duty Cycle and Duty Factor	Mode	Duty Cycle (%)	Duty Factor (dB)
	11b	100.00%	0.00
	11g	97.98%	0.09
	HT20	98.27%	0.08
	HT40	95.78%	0.19

1.1.8 Power Index of Test Tool

Modulation Mode	Test Frequency (MHz)	Power Index
11b	2412	11.5
11b	2437	11.5
11b	2462	12.5
11g	2412	13.5
11g	2437	13.5
11g	2462	14
HT20	2412	14
HT20	2437	13.5
HT20	2462	14
HT40	2422	12
HT40	2437	14
HT40	2452	13.5

1.2 Local Support Equipment List

Support Equipment List					
No.	Equipment	Brand	Model	FCC ID	Remarks
1	Earphone	Samsung	EHS64	---	---

1.3 Test Setup Chart

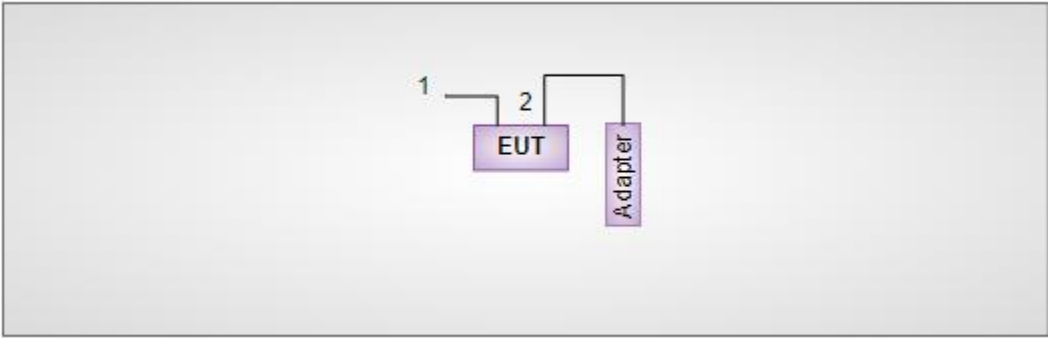
Test Setup Diagram	
	
No.	Signal cable / Length (m)
1	Audio, 1.2m non-shielded.
2	USB, 1m shielded.

1.4 The Equipment List

Test Item	Conducted Emission				
Test Site	Conduction room 1 / (CO01-WS)				
Tested Date	Dec. 08, 2021				
Instrument	Brand	Model No.	Serial No.	Calibration Date	Calibration Until
Receiver	R&S	ESR3	101658	Feb. 08, 2021	Feb. 07, 2022
LISN	R&S	ENV216	101579	Mar. 17, 2021	Mar. 16, 2022
LISN (Support Unit)	SCHWARZBECK	Schwarzbeck 8127	8127-666	Dec. 29, 2020	Dec. 28, 2021
RF Cable-CON	Woken	CFD200-NL	CFD200-NL-001	Oct. 19, 2021	Oct. 18, 2022
50 ohm terminal (Support Unit)	NA	50	04	May 25, 2021	May 24, 2022
Measurement Software	AUDIX	e3	6.120210k	NA	NA
Note: Calibration Interval of instruments listed above is one year.					

Test Item	Radiated Emission				
Test Site	966 chamber1 / (03CH01-WS)				
Tested Date	Dec. 06 ~ Dec. 10, 2021				
Instrument	Brand	Model No.	Serial No.	Calibration Date	Calibration Until
Receiver	R&S	ESR3	101657	Mar. 12, 2021	Mar. 11, 2022
Spectrum Analyzer	R&S	FSV40	101498	Nov. 29, 2021	Nov. 28, 2022
Loop Antenna	R&S	HFH2-Z2	100330	Nov. 08, 2021	Nov. 07, 2022
Bilog Antenna	SCHWARZBECK	VULB9168	VULB9168-522	Jun. 30, 2021	Jun. 29, 2022
Horn Antenna 1G-18G	SCHWARZBECK	BBHA 9120 D	BBHA 9120 D 1096	Dec. 03, 2021	Dec. 02, 2022
Horn Antenna 18G-40G	SCHWARZBECK	BBHA 9170	BBHA 9170508	Dec. 31, 2020	Dec. 30, 2021
Preamplifier	EMC	EMC02325	980225	Jun. 29, 2021	Jun. 28, 2022
Preamplifier	Agilent	83017A	MY39501308	Sep. 28, 2021	Sep. 27, 2022
Preamplifier	EMC	EMC184045B	980192	Jul. 14, 2021	Jul. 13, 2022
Loop Antenna Cable	KOAX KABEL	101354-BW	101354-BW	Oct. 05, 2021	Oct. 04, 2022
LF cable 3M	Woken	CFD400NL-LW	CFD400NL-001	Oct. 05, 2021	Oct. 04, 2022
LF cable 11M	EMC	EMCCFD400-NW-N W-11000	200801	Oct. 05, 2021	Oct. 04, 2022
LF cable 1M	EMC	EMCCFD400-NM-N M-1000	160502	Oct. 05, 2021	Oct. 04, 2022
RF Cable	HUBER+SUHNER	SUCOFLEX104	MY16019/4	Oct. 05, 2021	Oct. 04, 2022
RF Cable	HUBER+SUHNER	SUCOFLEX104	MY16014/4	Oct. 05, 2021	Oct. 04, 2022
Measurement Software	AUDIX	e3	6.120210g	NA	NA
Note: Calibration Interval of instruments listed above is one year.					

Test Item	RF Conducted				
Test Site	(TH01-WS)				
Tested Date	Dec. 21, 2021				
Instrument	Brand	Model No.	Serial No.	Calibration Date	Calibration Until
Spectrum Analyzer	R&S	FSV40	101063	Apr. 19, 2021	Apr. 18, 2022
Power Meter	Anritsu	ML2495A	1241002	Nov. 07, 2021	Nov. 06, 2022
Power Sensor	Anritsu	MA2411B	1207366	Nov. 07, 2021	Nov. 06, 2022
Measurement Software	Sporton	SENSE-15247_DTS	V5.10	NA	NA
Note: Calibration Interval of instruments listed above is one year.					

1.5 Test Standards

47 CFR FCC Part 15.247

ANSI C63.10-2013

1.6 Reference Guidance

FCC KDB 558074 D01 15.247 Meas Guidance v05r02

1.7 Deviation from Test Standard and Measurement Procedure

None

1.8 Measurement Uncertainty

The measurement uncertainties given below are based on a 95% confidence level (based on a coverage factor ($k=2$)).

Measurement Uncertainty	
Parameters	Uncertainty
Bandwidth	± 34.130 Hz
Conducted power	± 0.808 dB
Power density	± 0.583 dB
Conducted emission	± 2.715 dB
AC conducted emission	± 2.92 dB
Radiated emission ≤ 1 GHz	± 3.41 dB
Radiated emission > 1 GHz	± 4.59 dB

2 Test Configuration

2.1 Testing Facility

Test Laboratory	International Certification Corporation
Test Site	CO01-WS, 03CH01-WS, TH01-WS
Address of Test Site	No.3-1, Lane 6, Wen San 3rd St., Kwei Shan Dist., Tao Yuan City 33381, Taiwan (R.O.C.)

- FCC Designation No.: TW2732
- FCC site registration No.: 181692
- ISED#: 10807A
- CAB identifier: TW2732

2.2 The Worst Test Modes and Channel Details

Test item	Modulation Mode	Test Frequency (MHz)	Data Rate	Test Configuration
Conducted Emissions	HT40	2437	MCS 0	---
Radiated Emissions ≤1GHz	HT40	2437	MCS 0	---
Radiated Emissions >1GHz	11b	2412 / 2437 / 2462	1 Mbps	---
Maximum Output Power	11g	2412 / 2437 / 2462	6 Mbps	
6dB bandwidth	HT20	2412 / 2437 / 2462	MCS 0	
Power spectral density	HT40	2422 / 2437 / 2452	MCS 0	

NOTE:

1. The EUT was pretested with 3 orientations placed on the table for the radiated emission measurement – X, Y, and Z-plane. The **Y-plane** results were found as the worst case and were shown in this report.

3 Transmitter Test Results

3.1 Conducted Emissions

3.1.1 Limit of Conducted Emissions

Conducted Emissions Limit		
Frequency Emission (MHz)	Quasi-Peak	Average
0.15-0.5	66 - 56 *	56 - 46 *
0.5-5	56	46
5-30	60	50

Note 1: * Decreases with the logarithm of the frequency.

3.1.2 Test Procedures

1. The device is placed on a test table, raised 80 cm above the reference ground plane. The vertical conducting plane is located 40 cm to the rear of the device.
2. The device is connected to line impedance stabilization network (LISN) and other accessories are connected to other LISN. Measured levels of AC power line conducted emission are across the 50 Ω LISN port.
3. AC conducted emission measurements is made over frequency range from 150 kHz to 30 MHz.
4. This measurement was performed with AC 120V / 60Hz.

3.1.3 Test Setup

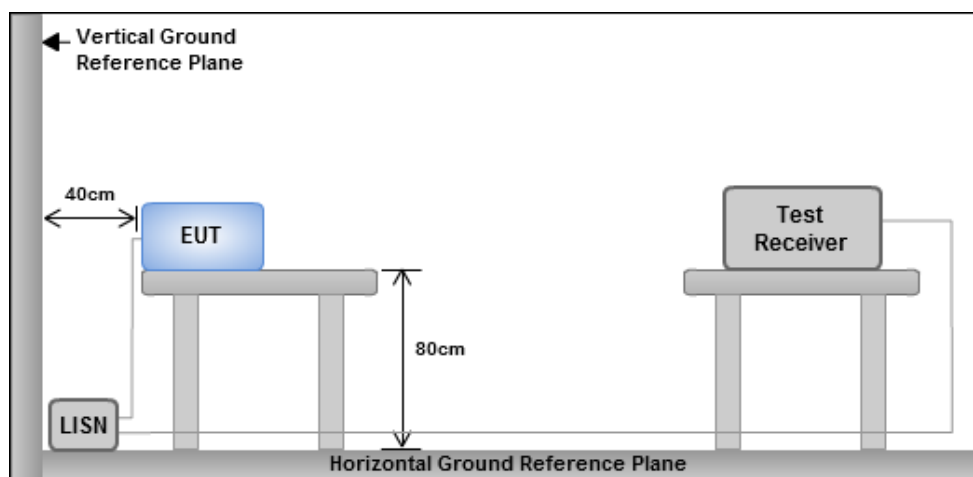

Note: 1. Support units were connected to second LISN.

2. Both of LISNs (AMN) are 80 cm from EUT and at least 80 cm from other units and other metal planes

3.1.4 Test Result of Conducted Emissions

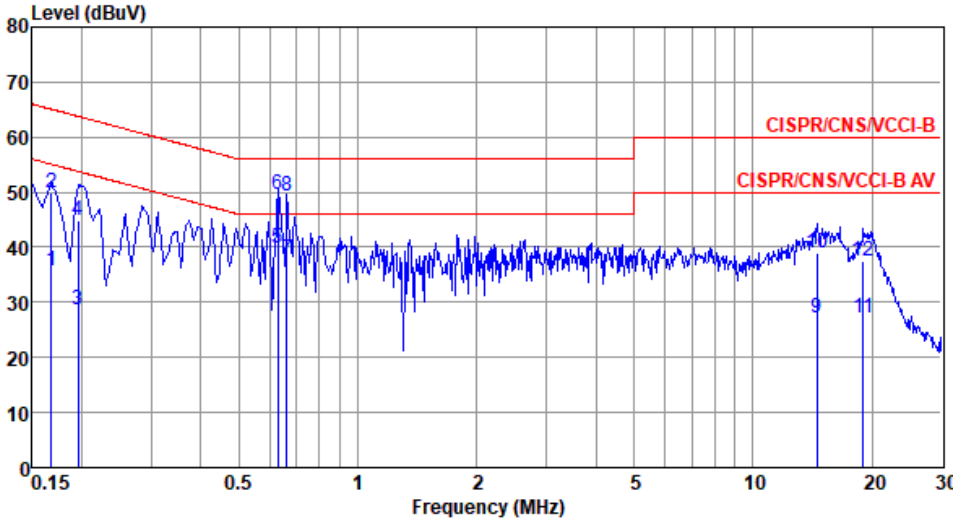
Modulation	HT40	Test Freq. (MHz)	2437																																																																																																																																		
Power Phase	Line																																																																																																																																				
<p>Test by : Roger Lu Temperature: 23°C Humidity: 61%</p>																																																																																																																																					
																																																																																																																																					
<table border="1"> <thead> <tr> <th></th> <th>Freq MHz</th> <th>Level dBuV</th> <th>Limit Line dBuV</th> <th>Over Limit dB</th> <th>Read Level dBuV</th> <th>Factor dB</th> <th>Cable loss dB</th> <th>Aux dB</th> <th>Remark</th> </tr> </thead> <tbody> <tr><td>1</td><td>0.168</td><td>35.82</td><td>55.08</td><td>-19.26</td><td>25.87</td><td>9.66</td><td>0.08</td><td>0.21</td><td>Average</td></tr> <tr><td>2</td><td>0.168</td><td>49.97</td><td>65.08</td><td>-15.11</td><td>40.02</td><td>9.66</td><td>0.08</td><td>0.21</td><td>QP</td></tr> <tr><td>3</td><td>0.195</td><td>28.71</td><td>53.80</td><td>-25.09</td><td>18.76</td><td>9.65</td><td>0.08</td><td>0.22</td><td>Average</td></tr> <tr><td>4</td><td>0.195</td><td>44.73</td><td>63.80</td><td>-19.07</td><td>34.78</td><td>9.65</td><td>0.08</td><td>0.22</td><td>QP</td></tr> <tr><td>5*</td><td>0.627</td><td>39.84</td><td>46.00</td><td>-6.16</td><td>29.72</td><td>9.64</td><td>0.12</td><td>0.36</td><td>Average</td></tr> <tr><td>6</td><td>0.627</td><td>49.66</td><td>56.00</td><td>-6.34</td><td>39.54</td><td>9.64</td><td>0.12</td><td>0.36</td><td>QP</td></tr> <tr><td>7</td><td>0.661</td><td>37.90</td><td>46.00</td><td>-8.10</td><td>27.76</td><td>9.65</td><td>0.12</td><td>0.37</td><td>Average</td></tr> <tr><td>8</td><td>0.661</td><td>49.38</td><td>56.00</td><td>-6.62</td><td>39.24</td><td>9.65</td><td>0.12</td><td>0.37</td><td>QP</td></tr> <tr><td>9</td><td>14.517</td><td>27.17</td><td>50.00</td><td>-22.83</td><td>16.42</td><td>9.69</td><td>0.55</td><td>0.51</td><td>Average</td></tr> <tr><td>10</td><td>14.517</td><td>38.95</td><td>60.00</td><td>-21.05</td><td>28.20</td><td>9.69</td><td>0.55</td><td>0.51</td><td>QP</td></tr> <tr><td>11</td><td>19.021</td><td>27.17</td><td>50.00</td><td>-22.83</td><td>16.22</td><td>9.68</td><td>0.64</td><td>0.63</td><td>Average</td></tr> <tr><td>12</td><td>19.021</td><td>37.38</td><td>60.00</td><td>-22.62</td><td>26.43</td><td>9.68</td><td>0.64</td><td>0.63</td><td>QP</td></tr> </tbody> </table>					Freq MHz	Level dBuV	Limit Line dBuV	Over Limit dB	Read Level dBuV	Factor dB	Cable loss dB	Aux dB	Remark	1	0.168	35.82	55.08	-19.26	25.87	9.66	0.08	0.21	Average	2	0.168	49.97	65.08	-15.11	40.02	9.66	0.08	0.21	QP	3	0.195	28.71	53.80	-25.09	18.76	9.65	0.08	0.22	Average	4	0.195	44.73	63.80	-19.07	34.78	9.65	0.08	0.22	QP	5*	0.627	39.84	46.00	-6.16	29.72	9.64	0.12	0.36	Average	6	0.627	49.66	56.00	-6.34	39.54	9.64	0.12	0.36	QP	7	0.661	37.90	46.00	-8.10	27.76	9.65	0.12	0.37	Average	8	0.661	49.38	56.00	-6.62	39.24	9.65	0.12	0.37	QP	9	14.517	27.17	50.00	-22.83	16.42	9.69	0.55	0.51	Average	10	14.517	38.95	60.00	-21.05	28.20	9.69	0.55	0.51	QP	11	19.021	27.17	50.00	-22.83	16.22	9.68	0.64	0.63	Average	12	19.021	37.38	60.00	-22.62	26.43	9.68	0.64	0.63	QP
	Freq MHz	Level dBuV	Limit Line dBuV	Over Limit dB	Read Level dBuV	Factor dB	Cable loss dB	Aux dB	Remark																																																																																																																												
1	0.168	35.82	55.08	-19.26	25.87	9.66	0.08	0.21	Average																																																																																																																												
2	0.168	49.97	65.08	-15.11	40.02	9.66	0.08	0.21	QP																																																																																																																												
3	0.195	28.71	53.80	-25.09	18.76	9.65	0.08	0.22	Average																																																																																																																												
4	0.195	44.73	63.80	-19.07	34.78	9.65	0.08	0.22	QP																																																																																																																												
5*	0.627	39.84	46.00	-6.16	29.72	9.64	0.12	0.36	Average																																																																																																																												
6	0.627	49.66	56.00	-6.34	39.54	9.64	0.12	0.36	QP																																																																																																																												
7	0.661	37.90	46.00	-8.10	27.76	9.65	0.12	0.37	Average																																																																																																																												
8	0.661	49.38	56.00	-6.62	39.24	9.65	0.12	0.37	QP																																																																																																																												
9	14.517	27.17	50.00	-22.83	16.42	9.69	0.55	0.51	Average																																																																																																																												
10	14.517	38.95	60.00	-21.05	28.20	9.69	0.55	0.51	QP																																																																																																																												
11	19.021	27.17	50.00	-22.83	16.22	9.68	0.64	0.63	Average																																																																																																																												
12	19.021	37.38	60.00	-22.62	26.43	9.68	0.64	0.63	QP																																																																																																																												
<p>Note 1: Level (dBuV) = Read Level (dBuV) + LISN Factor (dB) + Cable Loss (dB) + Aux (dB). 2: Over Limit (dB) = Level (dBuV) – Limit Line (dBuV).</p>																																																																																																																																					

Modulation	HT40	Test Freq. (MHz)	2437
Power Phase	Neutral		

Test by : Roger Lu Temperature: 23°C Humidity: 61%

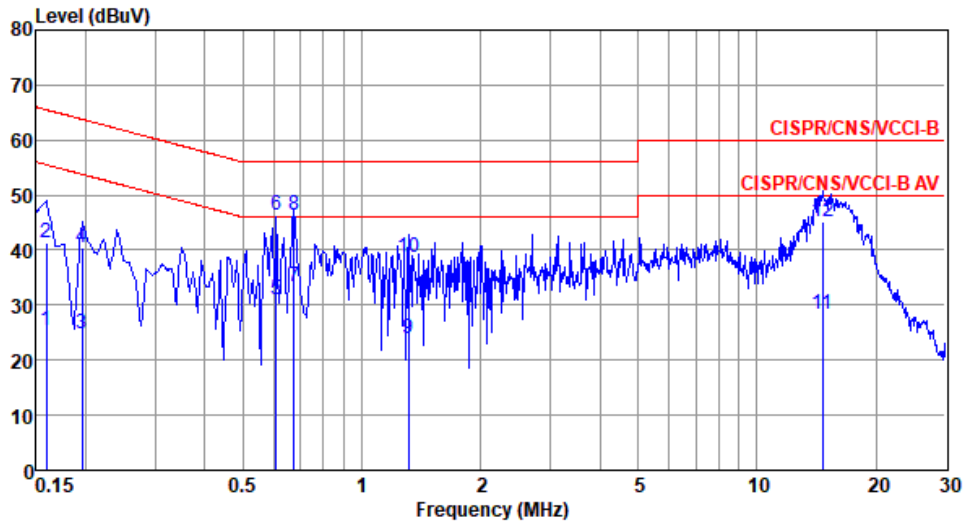

	Freq MHz	Level dBuV	Limit Line dBuV	Over Limit dB	Read Level dBuV	Factor dB	Cable loss dB	Aux dB	Remark
1	0.159	25.44	55.52	-30.08	15.51	9.69	0.08	0.16	Average
2	0.159	41.38	65.52	-24.14	31.45	9.69	0.08	0.16	QP
3	0.195	24.66	53.80	-29.14	14.72	9.68	0.08	0.18	Average
4	0.195	40.48	63.80	-23.32	30.54	9.68	0.08	0.18	QP
5	0.608	30.98	46.00	-15.02	20.96	9.67	0.12	0.23	Average
6*	0.608	46.24	56.00	-9.76	36.22	9.67	0.12	0.23	QP
7	0.672	33.33	46.00	-12.67	23.28	9.68	0.13	0.24	Average
8	0.672	46.24	56.00	-9.76	36.19	9.68	0.13	0.24	QP
9	1.310	23.95	46.00	-22.05	13.80	9.68	0.18	0.29	Average
10	1.310	38.59	56.00	-17.41	28.44	9.68	0.18	0.29	QP
11	14.672	28.23	50.00	-21.77	17.41	9.80	0.55	0.47	Average
12	14.672	45.25	60.00	-14.75	34.43	9.80	0.55	0.47	QP

Note 1: Level (dBuV) = Read Level (dBuV) + LISN Factor (dB) + Cable Loss (dB) + Aux (dB).
 Note 2: Over Limit (dB) = Level (dBuV) – Limit Line (dBuV).

3.2 6dB and Occupied Bandwidth

3.2.1 Limit of 6dB Bandwidth

The minimum 6dB bandwidth shall be at least 500 kHz.

3.2.2 Test Procedures

6dB Bandwidth

1. Set resolution bandwidth (RBW) = 100 kHz, Video bandwidth = 300 kHz.
2. Detector = Peak, Trace mode = max hold.
3. Sweep = auto couple, Allow the trace to stabilize.
4. Measure the maximum width of the emission that is constrained by the frequencies associated with the two outermost amplitude points (upper and lower) that are attenuated by 6dB relative to the maximum level measured in the fundamental emission.

Occupied Bandwidth

1. Set resolution bandwidth (RBW) = 1% ~ 5 % of OBW, Video bandwidth = 3 x RBW
2. Detector = Sample, Trace mode = max hold.
3. Sweep = auto couple, Allow the trace to stabilize.
4. Use the OBW measurement function of spectrum analyzer to measure the occupied bandwidth.

3.2.3 Test Setup

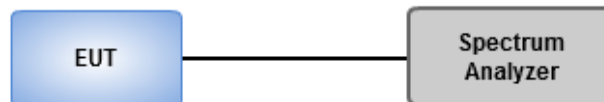

3.2.4 Test Result of 6dB and Occupied Bandwidth

Ambient Condition	22°C / 65%	Tested By	Roger Lu
-------------------	------------	-----------	----------

Summary

Mode	Max-N dB (Hz)	Max-OBW (Hz)	ITU-Code	Min-N dB (Hz)	Min-OBW (Hz)
2.4-2.4835GHz	-	-	-	-	-
802.11b_Nss1,(1Mbps)_1TX	8.116M	12.88M	12M9G1D	8.043M	12.446M
802.11g_Nss1,(6Mbps)_1TX	16.014M	16.498M	16M5D1D	14.203M	16.353M
802.11n HT20_Nss1,(MCS0)_1TX	15.942M	17.583M	17M6D1D	13.841M	17.438M
802.11n HT40_Nss1,(MCS0)_1TX	35.072M	36.469M	36M5D1D	30.145M	35.601M

Max-N dB = Maximum 6dB down bandwidth; **Max-OBW** = Maximum 99% occupied bandwidth;
Min-N dB = Minimum 6dB down bandwidth; **Min-OBW** = Minimum 99% occupied bandwidth;

Result

Mode	Result	Limit (Hz)	Port 1-N dB (Hz)	Port 1-OBW (Hz)
802.11b_Nss1,(1Mbps)_1TX	-	-	-	-
2412MHz	Pass	500k	8.043M	12.446M
2437MHz	Pass	500k	8.116M	12.88M
2462MHz	Pass	500k	8.116M	12.59M
802.11g_Nss1,(6Mbps)_1TX	-	-	-	-
2412MHz	Pass	500k	14.42M	16.353M
2437MHz	Pass	500k	16.014M	16.498M
2462MHz	Pass	500k	14.203M	16.425M
802.11n HT20_Nss1,(MCS0)_1TX	-	-	-	-
2412MHz	Pass	500k	13.841M	17.438M
2437MHz	Pass	500k	15.942M	17.583M
2462MHz	Pass	500k	13.841M	17.511M
802.11n HT40_Nss1,(MCS0)_1TX	-	-	-	-
2422MHz	Pass	500k	30.145M	35.601M
2437MHz	Pass	500k	34.348M	36.469M
2452MHz	Pass	500k	35.072M	35.89M

Port X-N dB = Port X 6dB down bandwidth; **Port X-OBW** = Port X 99% occupied bandwidth;

802.11b_Nss1,(1Mbps)_1TX

EBW

2412MHz

CF
2.412GHz
Span
50MHz
RBW
100kHz
VBW
300kHz
Sweep Time
1.08ms
Detector Type
Peak
Port 1

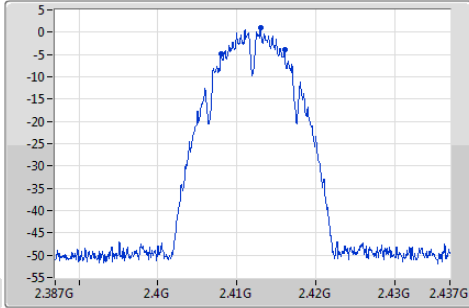

CF
2.412GHz
Span
50MHz
RBW
200kHz
VBW
1MHz
Sweep Time
1.02ms
Detector Type
Sample

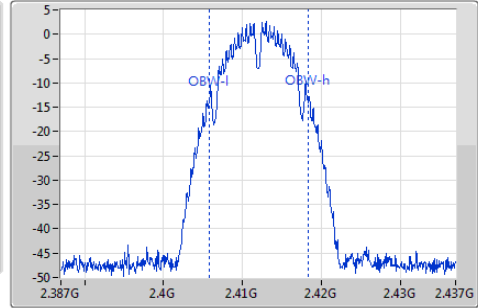

6dB(Hz)	Fl-6dB(Hz)	Fh-6dB(Hz)	OBW(Hz)	Fl-OBW(Hz)	Fh-OBW(Hz)	Limit(Hz)	Port
8.043M	2.408014G	2.416058G	12.446M	2.405849G	2.418295G	500k	1

802.11b_Nss1,(1Mbps)_1TX

EBW

2437MHz

CF
2.437GHz
Span
50MHz
RBW
100kHz
VBW
300kHz
Sweep Time
1.08ms
Detector Type
Peak
Port 1

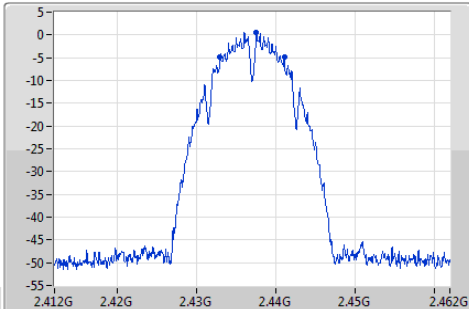

CF
2.437GHz
Span
50MHz
RBW
200kHz
VBW
1MHz
Sweep Time
1.02ms
Detector Type
Sample

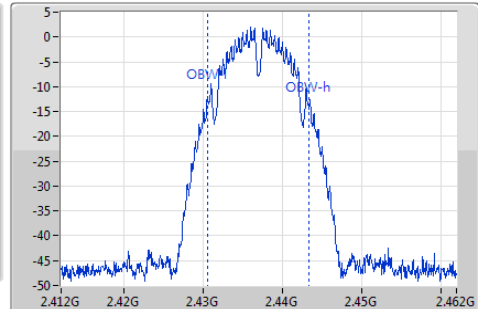

6dB(Hz)	Fl-6dB(Hz)	Fh-6dB(Hz)	OBW(Hz)	Fl-OBW(Hz)	Fh-OBW(Hz)	Limit(Hz)	Port
8.116M	2.432942G	2.441058G	12.88M	2.430488G	2.443368G	500k	1

802.11b_Nss1,(1Mbps)_1TX

EBW

2462MHz

CF
2.462GHz
Span
50MHz
RBW
100kHz
VBW
300kHz
Sweep Time
1.08ms
Detector Type
Peak
Port 1

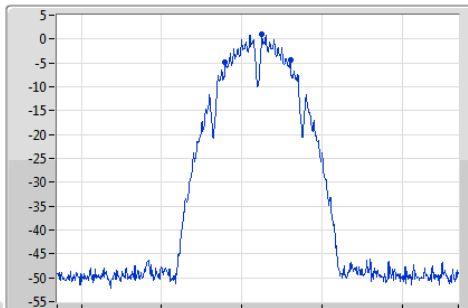

CF
2.462GHz
Span
50MHz
RBW
200kHz
VBW
1MHz
Sweep Time
1.02ms
Detector Type
Sample

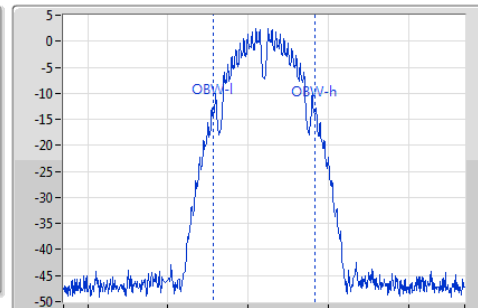

6dB(Hz)	Fl-6dB(Hz)	Fh-6dB(Hz)	OBW(Hz)	Fl-OBW(Hz)	Fh-OBW(Hz)	Limit(Hz)	Port
8.116M	2.457942G	2.466058G	12.59M	2.455705G	2.468295G	500k	1

802.11g_Nss1,(6Mbps)_1TX

EBW

2412MHz

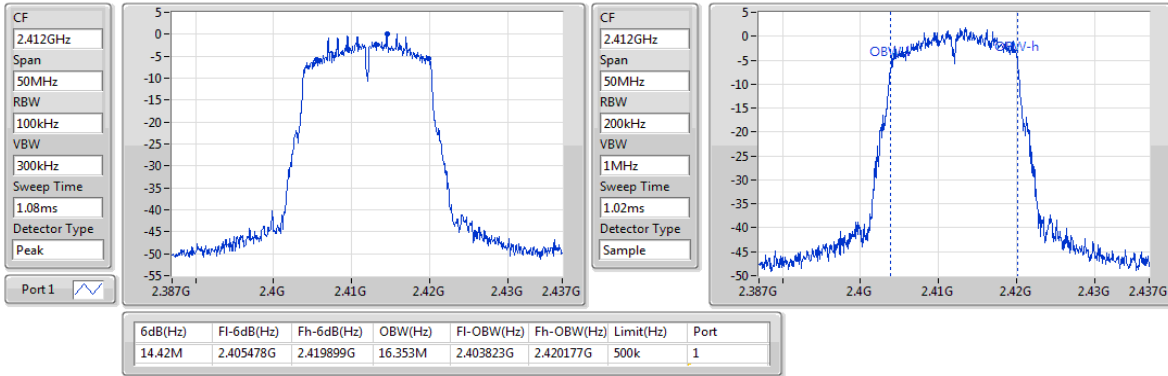

802.11g_Nss1,(6Mbps)_1TX

EBW

2437MHz

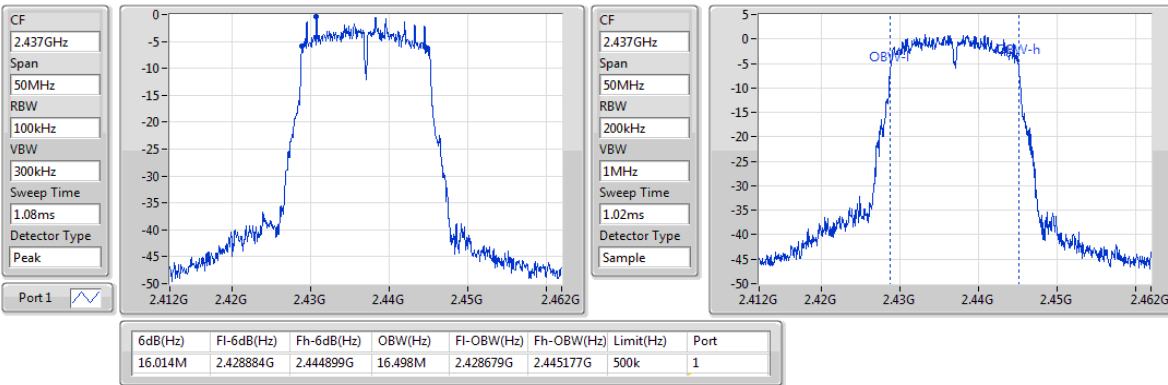

802.11g_Nss1,(6Mbps)_1TX

EBW

2462MHz

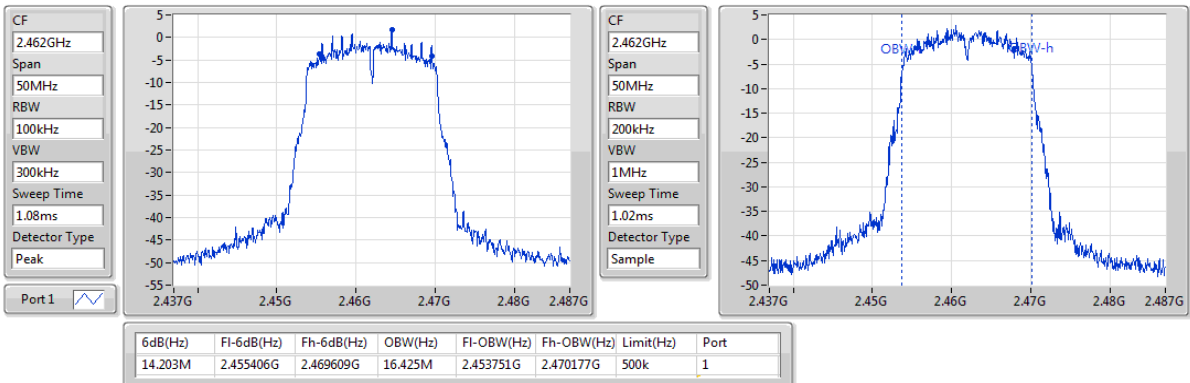

802.11n HT20_Nss1,(MCS0)_1TX

EBW

2412MHz

CF
2.412GHz
Span
50MHz
RBW
100kHz
VBW
300kHz
Sweep Time
1.08ms
Detector Type
Peak
Port 1

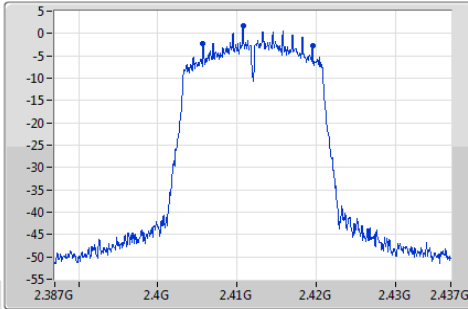

CF
2.412GHz
Span
50MHz
RBW
200kHz
VBW
1MHz
Sweep Time
1.02ms
Detector Type
Sample

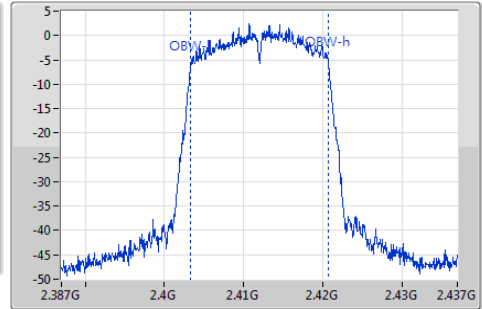

6dB(Hz)	Fl-6dB(Hz)	Fh-6dB(Hz)	OBW(Hz)	Fl-OBW(Hz)	Fh-OBW(Hz)	Limit(Hz)	Port
13.841M	2.405696G	2.419536G	17.438M	2.403317G	2.420755G	500k	1

802.11n HT20_Nss1,(MCS0)_1TX

EBW

2437MHz

CF
2.437GHz
Span
50MHz
RBW
100kHz
VBW
300kHz
Sweep Time
1.08ms
Detector Type
Peak
Port 1

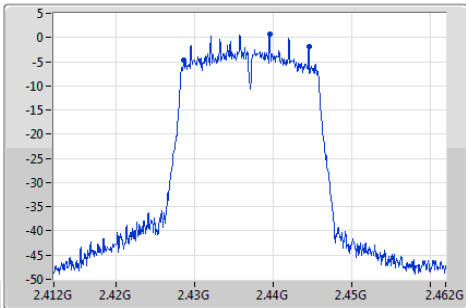

CF
2.437GHz
Span
50MHz
RBW
200kHz
VBW
1MHz
Sweep Time
1.02ms
Detector Type
Sample

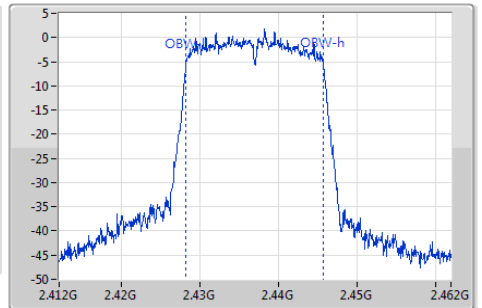

6dB(Hz)	Fl-6dB(Hz)	Fh-6dB(Hz)	OBW(Hz)	Fl-OBW(Hz)	Fh-OBW(Hz)	Limit(Hz)	Port
15.942M	2.428594G	2.444536G	17.583M	2.428172G	2.445755G	500k	1

802.11n HT20_Nss1,(MCS0)_1TX

EBW

2462MHz

CF
2.462GHz
Span
50MHz
RBW
100kHz
VBW
300kHz
Sweep Time
1.08ms
Detector Type
Peak
Port 1

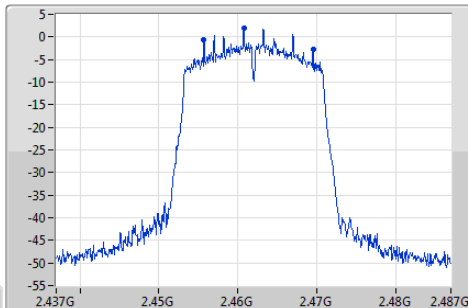

CF
2.462GHz
Span
50MHz
RBW
200kHz
VBW
1MHz
Sweep Time
1.02ms
Detector Type
Sample

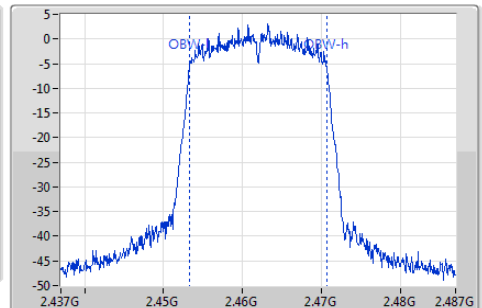

6dB(Hz)	Fl-6dB(Hz)	Fh-6dB(Hz)	OBW(Hz)	Fl-OBW(Hz)	Fh-OBW(Hz)	Limit(Hz)	Port
13.841M	2.455696G	2.469536G	17.511M	2.453245G	2.470755G	500k	1

802.11n HT40_Nss1,(MCS0)_1TX

EBW

2422MHz

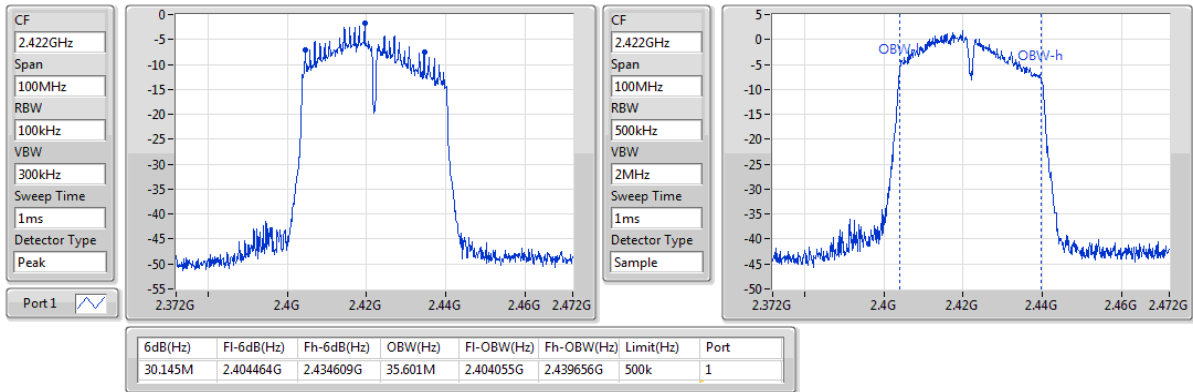

802.11n HT40_Nss1,(MCS0)_1TX

EBW

2437MHz

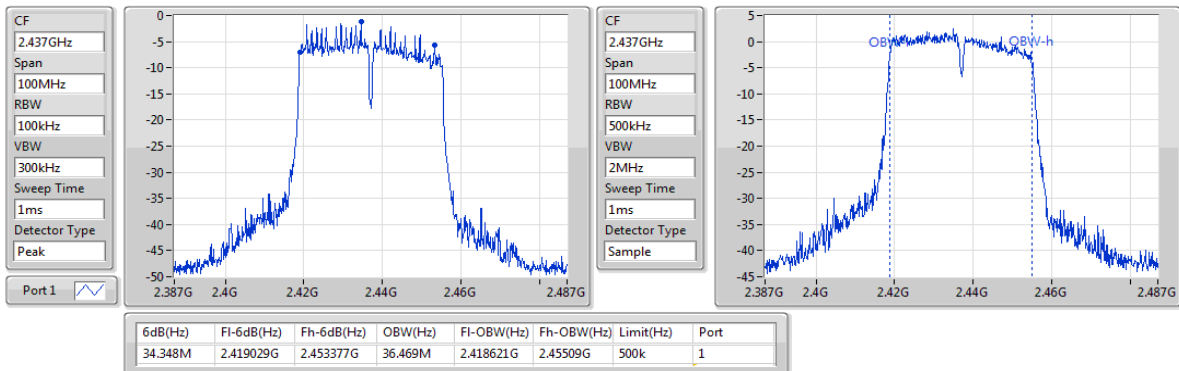

802.11n HT40_Nss1,(MCS0)_1TX

EBW

2452MHz

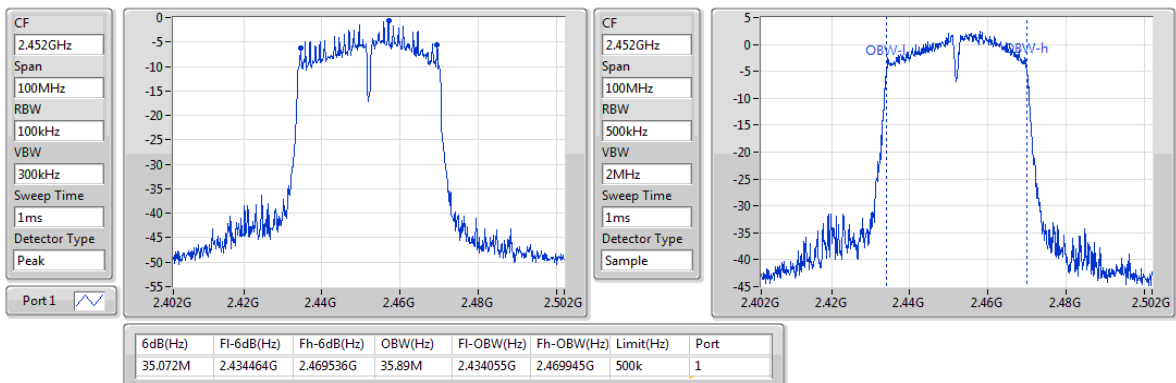

3.3 RF Output Power

3.3.1 Limit of RF Output Power

Conducted power shall not exceed 1Watt.

Antenna gain $\leq 6\text{dBi}$, no any corresponding reduction is in output power limit.

3.3.2 Test Procedures

A broadband RF power meter is used for output power measurement. The video bandwidth of power meter is greater than DTS bandwidth of EUT. If duty cycle of test signal is not 100 %, trigger and gating function of power meter will be enabled to capture transmission burst for measuring output power.

3.3.3 Test Setup

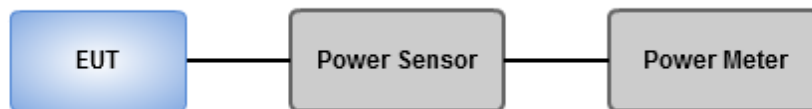

3.3.4 Test Result of Maximum Output Power

Ambient Condition	22°C / 65%	Tested By	Roger Lu
-------------------	------------	-----------	----------

Summary of Peak Conducted Output Power

Mode	Total Power (dBm)	Total Power (W)
2.4-2.4835GHz	-	-
802.11b_Nss1,(1Mbps)_1TX	12.80	0.01905
802.11g_Nss1,(6Mbps)_1TX	20.82	0.12078
802.11n HT20_Nss1,(MCS0)_1TX	20.74	0.11858
802.11n HT40_Nss1,(MCS0)_1TX	20.95	0.12445

Result

Mode	Result	DG (dBi)	Port 1 (dBm)	Total Power (dBm)	Power Limit (dBm)	EIRP (dBm)	EIRP Limit (dBm)
802.11b_Nss1,(1Mbps)_1TX	-	-	-	-	-	-	-
2412MHz	Pass	5.46	12.44	12.44	30.00	17.90	36.00
2437MHz	Pass	5.46	12.56	12.56	30.00	18.02	36.00
2462MHz	Pass	5.46	12.80	12.80	30.00	18.26	36.00
802.11g_Nss1,(6Mbps)_1TX	-	-	-	-	-	-	-
2412MHz	Pass	5.46	20.67	20.67	30.00	26.13	36.00
2437MHz	Pass	5.46	20.75	20.75	30.00	26.21	36.00
2462MHz	Pass	5.46	20.82	20.82	30.00	26.28	36.00
802.11n HT20_Nss1,(MCS0)_1TX	-	-	-	-	-	-	-
2412MHz	Pass	5.46	20.69	20.69	30.00	26.15	36.00
2437MHz	Pass	5.46	20.57	20.57	30.00	26.03	36.00
2462MHz	Pass	5.46	20.74	20.74	30.00	26.20	36.00
802.11n HT40_Nss1,(MCS0)_1TX	-	-	-	-	-	-	-
2422MHz	Pass	5.46	19.28	19.28	30.00	24.74	36.00
2437MHz	Pass	5.46	20.95	20.95	30.00	26.41	36.00
2452MHz	Pass	5.46	20.62	20.62	30.00	26.08	36.00

DG = Directional Gain; **Port X** = Port X output power

Summary of Conducted (Average) Output Power

Mode	Total Power (dBm)	Total Power (W)
2.4-2.4835GHz	-	-
802.11b_Nss1,(1Mbps)_1TX	10.38	0.01091
802.11g_Nss1,(6Mbps)_1TX	11.84	0.01528
802.11n HT20_Nss1,(MCS0)_1TX	11.82	0.01521
802.11n HT40_Nss1,(MCS0)_1TX	11.89	0.01545

Result

Mode	Result	DG (dBi)	Port 1 (dBm)	Total Power (dBm)	Power Limit (dBm)	EIRP (dBm)	EIRP Limit (dBm)
802.11b_Nss1,(1Mbps)_1TX	-	-	-	-	-	-	-
2412MHz	Pass	5.46	9.79	9.79	-	15.25	-
2437MHz	Pass	5.46	10.10	10.10	-	15.56	-
2462MHz	Pass	5.46	10.38	10.38	-	15.84	-
802.11g_Nss1,(6Mbps)_1TX	-	-	-	-	-	-	-
2412MHz	Pass	5.46	11.72	11.72	-	17.18	-
2437MHz	Pass	5.46	11.79	11.79	-	17.25	-
2462MHz	Pass	5.46	11.84	11.84	-	17.30	-
802.11n HT20_Nss1,(MCS0)_1TX	-	-	-	-	-	-	-
2412MHz	Pass	5.46	11.78	11.78	-	17.24	-
2437MHz	Pass	5.46	11.68	11.68	-	17.14	-
2462MHz	Pass	5.46	11.82	11.82	-	17.28	-
802.11n HT40_Nss1,(MCS0)_1TX	-	-	-	-	-	-	-
2422MHz	Pass	5.46	10.12	10.12	-	15.58	-
2437MHz	Pass	5.46	11.89	11.89	-	17.35	-
2452MHz	Pass	5.46	11.58	11.58	-	17.04	-

DG = Directional Gain; **Port X** = Port X output power

Note : Conducted average output power is for reference only

3.4 Power Spectral Density

3.4.1 Limit of Power Spectral Density

Power spectral density shall not be greater than 8 dBm in any 3 kHz band.

3.4.2 Test Procedures

Peak PSD

1. Set the RBW = 3 kHz, VBW = 10 kHz.
2. Detector = Peak, Sweep time = auto couple.
3. Trace mode = max hold, allow trace to fully stabilize.
4. Use the peak marker function to determine the maximum amplitude level.

Average PSD, duty cycle \geq 98%

1. Set the RBW = 30 kHz, VBW = 100 kHz.
2. Detector = RMS, Sweep time = auto couple.
3. Sweep time = auto couple.
4. Employ trace averaging (RMS) mode over a minimum of 100 traces.
5. Use the peak marker function to determine the maximum amplitude level.

Average PSD, duty cycle $<$ 98%

1. Set the RBW = 30 kHz, VBW = 100 kHz. Detector = RMS.
2. Set the sweep time to: ≥ 10 (number of measurement points in sweep) x (total on/off period of the transmitted signal).
3. Perform the measurement over a single sweep.
4. Use the peak marker function to determine the maximum amplitude level.
5. Add $10 \log (1/x)$, where x is the duty cycle.

3.4.3 Test Setup

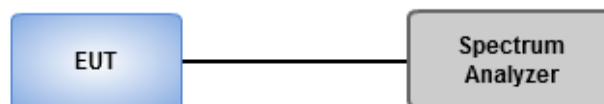

3.4.4 Test Result of Power Spectral Density

Ambient Condition	22°C / 65%	Tested By	Roger Lu
--------------------------	------------	------------------	----------

Summary

Mode	PD (dBm/3kHz)
2.4-2.4835GHz	-
802.11b_Nss1,(1Mbps)_1TX	-13.73
802.11g_Nss1,(6Mbps)_1TX	-12.88
802.11n HT20_Nss1,(MCS0)_1TX	-12.88
802.11n HT40_Nss1,(MCS0)_1TX	-16.23

Result

Mode	Result	DG (dBi)	Port 1 (dBm/3kHz)	PD (dBm/3kHz)	PD Limit (dBm/3kHz)
802.11b_Nss1,(1Mbps)_1TX	-	-	-	-	-
2412MHz	Pass	5.46	-13.73	-13.73	8.00
2437MHz	Pass	5.46	-14.50	-14.50	8.00
2462MHz	Pass	5.46	-14.13	-14.13	8.00
802.11g_Nss1,(6Mbps)_1TX	-	-	-	-	-
2412MHz	Pass	5.46	-14.56	-14.56	8.00
2437MHz	Pass	5.46	-14.63	-14.63	8.00
2462MHz	Pass	5.46	-12.88	-12.88	8.00
802.11n HT20_Nss1,(MCS0)_1TX	-	-	-	-	-
2412MHz	Pass	5.46	-13.25	-13.25	8.00
2437MHz	Pass	5.46	-12.88	-12.88	8.00
2462MHz	Pass	5.46	-14.07	-14.07	8.00
802.11n HT40_Nss1,(MCS0)_1TX	-	-	-	-	-
2422MHz	Pass	5.46	-17.78	-17.78	8.00
2437MHz	Pass	5.46	-17.13	-17.13	8.00
2452MHz	Pass	5.46	-16.23	-16.23	8.00

DG = Directional Gain;

PD = Power density; **Port X** = Port X power density;

802.11b_Nss1,(1Mbps)_1TX

PSD

2412MHz

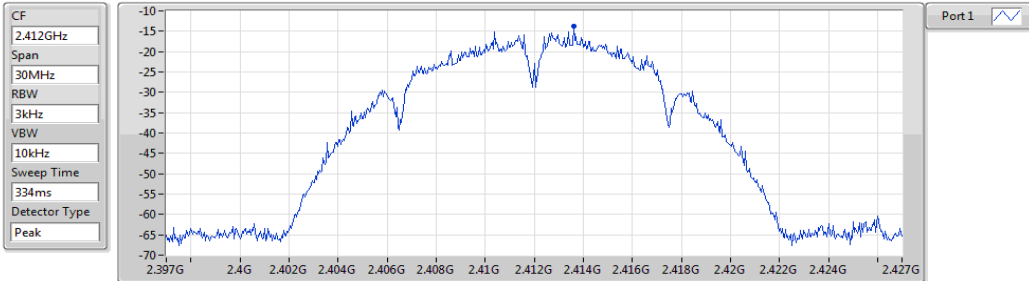

Sum	PD	Port 1
(dBm/RBW)	(dBm/RBW)	(dBm/RBW)
-13.73	-13.73	-13.73

802.11b_Nss1,(1Mbps)_1TX

PSD

2437MHz

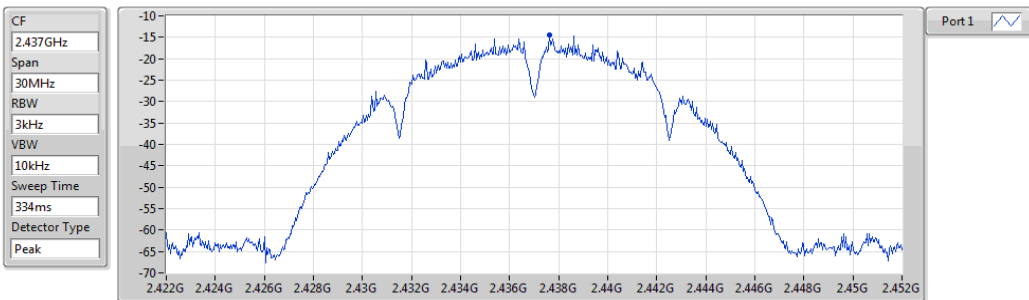

Sum	PD	Port 1
(dBm/RBW)	(dBm/RBW)	(dBm/RBW)
-14.50	-14.50	-14.50

802.11b_Nss1,(1Mbps)_1TX

PSD

2462MHz

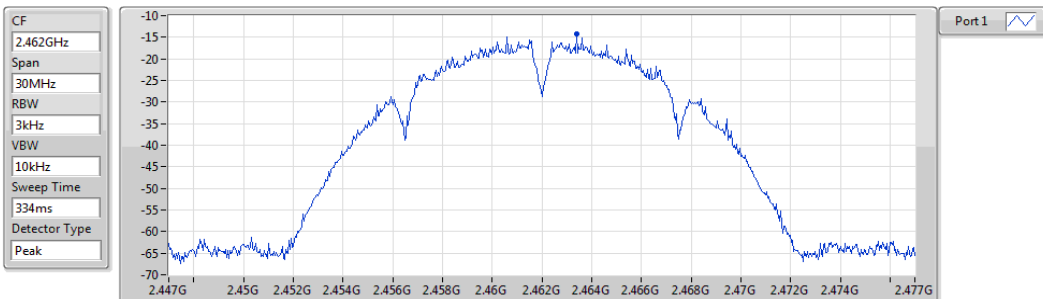

Sum	PD	Port 1
(dBm/RBW)	(dBm/RBW)	(dBm/RBW)
-14.13	-14.13	-14.13

802.11g_Nss1,(6Mbps)_1TX

PSD

2412MHz

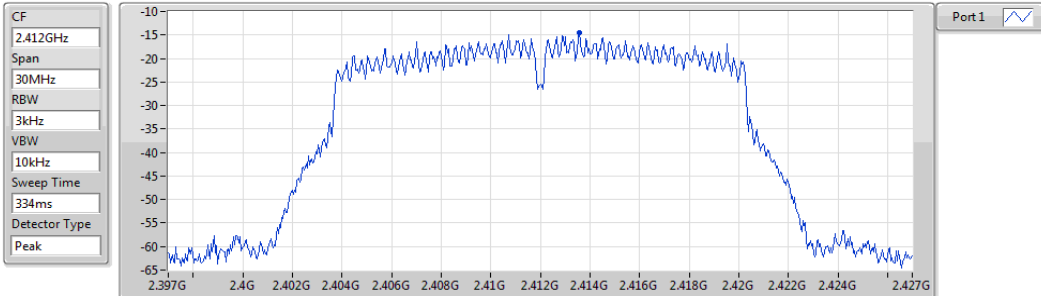

Sum	PD	Port 1
(dBm/RBW)	(dBm/RBW)	(dBm/RBW)
-14.56	-14.56	-14.56

802.11g_Nss1,(6Mbps)_1TX

PSD

2437MHz

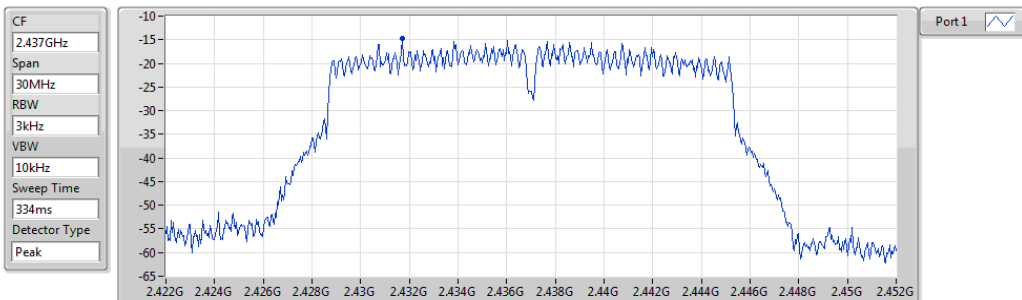

Sum	PD	Port 1
(dBm/RBW)	(dBm/RBW)	(dBm/RBW)
-14.63	-14.63	-14.63

802.11g_Nss1,(6Mbps)_1TX

PSD

2462MHz

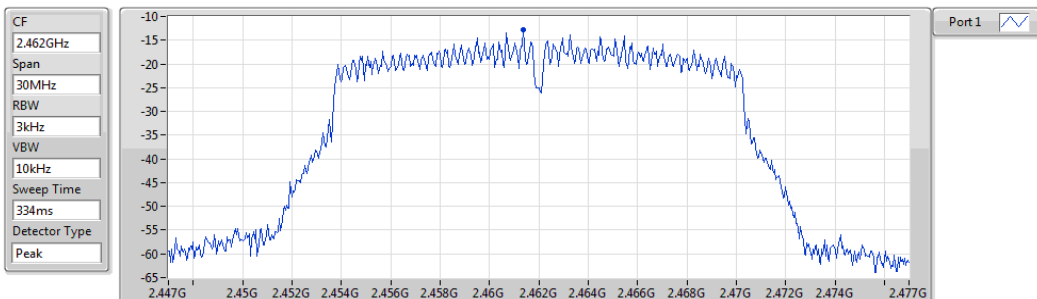

Sum	PD	Port 1
(dBm/RBW)	(dBm/RBW)	(dBm/RBW)
-12.88	-12.88	-12.88

802.11n HT20_Nss1,(MCS0)_1TX

PSD

2412MHz

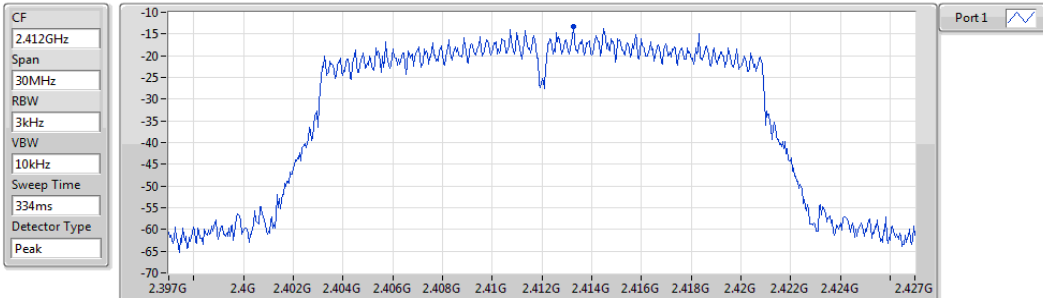

Sum	PD	Port 1
(dBm/RBW)	(dBm/RBW)	(dBm/RBW)
-13.25	-13.25	-13.25

802.11n HT20_Nss1,(MCS0)_1TX

PSD

2437MHz

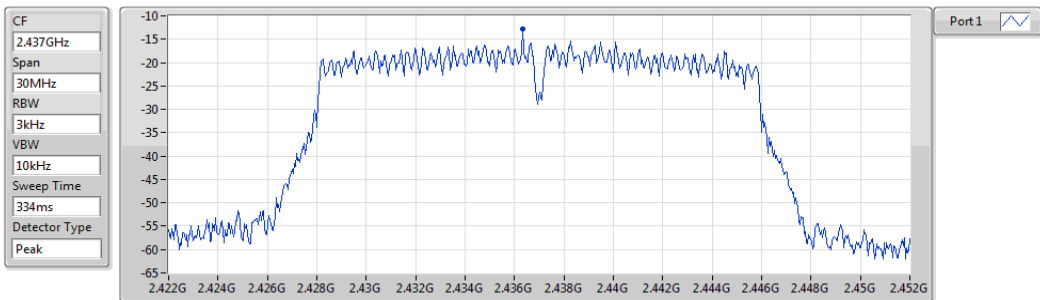

Sum	PD	Port 1
(dBm/RBW)	(dBm/RBW)	(dBm/RBW)
-12.88	-12.88	-12.88

802.11n HT20_Nss1,(MCS0)_1TX

PSD

2462MHz

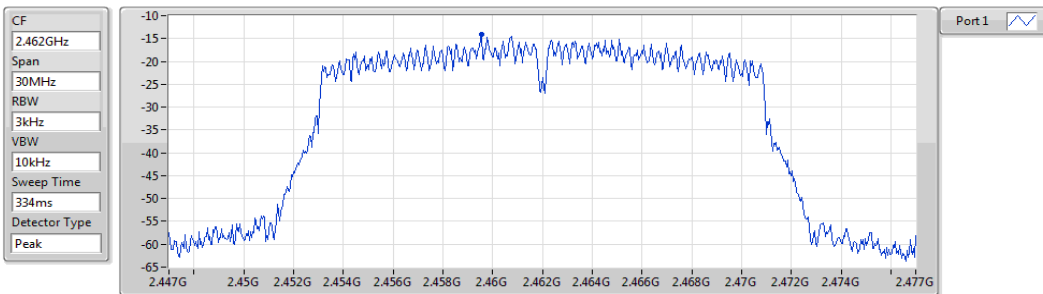

Sum	PD	Port 1
(dBm/RBW)	(dBm/RBW)	(dBm/RBW)
-14.07	-14.07	-14.07

802.11n HT40_Nss1,(MCS0)_1TX

PSD

2422MHz

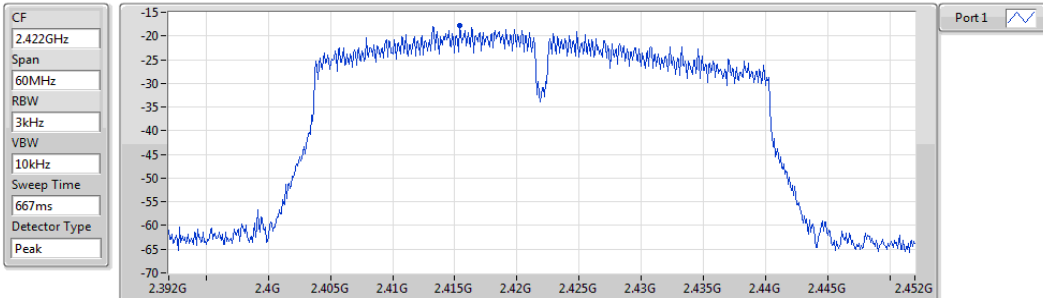

Sum	PD	Port 1
(dBm/RBW)	(dBm/RBW)	(dBm/RBW)
-17.78	-17.78	-17.78

802.11n HT40_Nss1,(MCS0)_1TX

PSD

2437MHz

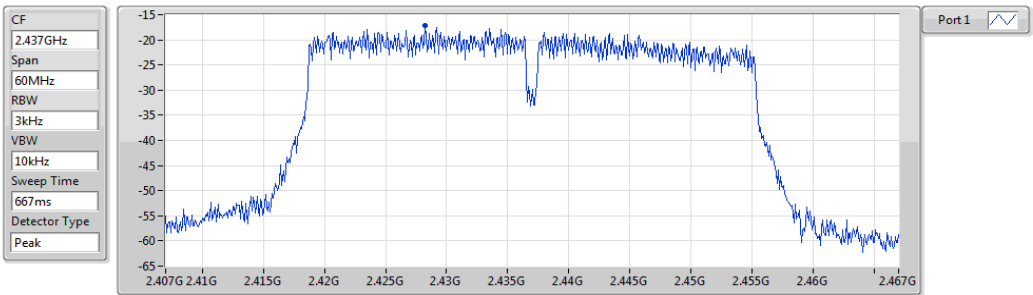

Sum	PD	Port 1
(dBm/RBW)	(dBm/RBW)	(dBm/RBW)
-17.13	-17.13	-17.13

802.11n HT40_Nss1,(MCS0)_1TX

PSD

2452MHz

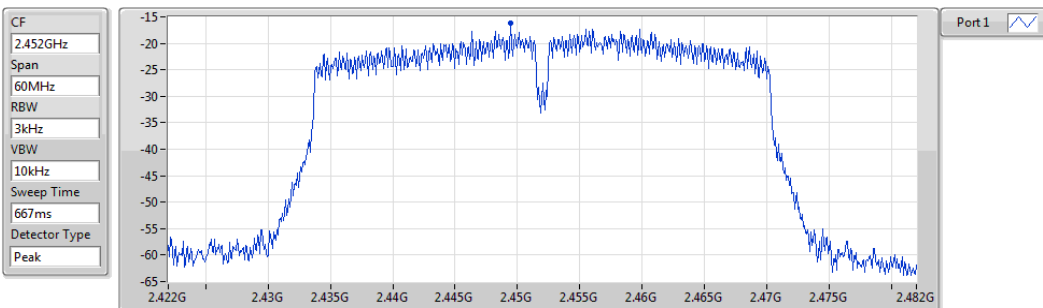

Sum	PD	Port 1
(dBm/RBW)	(dBm/RBW)	(dBm/RBW)
-16.23	-16.23	-16.23

3.5 Unwanted Emissions into Restricted Frequency Bands

3.5.1 Limit of Unwanted Emissions into Restricted Frequency Bands

Restricted Band Emissions Limit			
Frequency Range (MHz)	Field Strength (uV/m)	Field Strength (dBuV/m)	Measure Distance (m)
0.009~0.490	2400/F(kHz)	48.5 - 13.8	300
0.490~1.705	24000/F(kHz)	33.8 - 23	30
1.705~30.0	30	29	30
30~88	100	40	3
88~216	150	43.5	3
216~960	200	46	3
Above 960	500	54	3

Note 1:
Quasi-Peak value is measured for frequency below 1GHz except for 9–90 kHz, 110–490 kHz frequency band. Peak and average value are measured for frequency above 1GHz. The limit on average radio frequency emission is as above table. The limit on peak radio frequency emissions is 20 dB above the maximum permitted average emission limit

Note 2:
Measurements may be performed at a distance other than what is specified provided. When performing measurements at a distance other than that specified, the results shall be extrapolated to the specified distance using an extrapolation factor as below, Frequency at or above 30 MHz: 20 dB/decade Frequency below 30 MHz: 40 dB/decade.

3.5.2 Test Procedures

1. Measurement is made at a semi-anechoic chamber that incorporates a turntable allowing a EUT rotation of 360°. A continuously-rotating, remotely-controlled turntable is installed at the test site to support the EUT and facilitate determination of the direction of maximum radiation for each EUT emission frequency. The EUT is placed at test table. For emissions testing at or below 1 GHz, the table height is 80 cm above the reference ground plane. For emission measurements above 1 GHz, the table height is 1.5 m
2. Measurement is made with the antenna positioned in both the horizontal and vertical planes of polarization. The measurement antenna is varied in height (1m ~ 4m) above the reference ground plane to obtain the maximum signal strength. Distance between EUT and antenna is 3 m.
3. This investigation is performed with the EUT rotated 360°, the antenna height scanned between 1 m and 4 m, and the antenna rotated to repeat the measurements for both the horizontal and vertical antenna polarizations.

Note:

1. 120kHz measurement bandwidth of test receiver and Quasi-peak detector is for radiated emission below 1GHz.
2. RBW=1MHz, VBW=3MHz and Peak detector is for peak measured value of radiated emission above 1GHz.
3. RBW=1MHz, VBW=1/T and Peak detector is for average measured value of radiated emission above 1GHz.

3.5.3 Test Setup

Radiated Emissions below 1 GHz

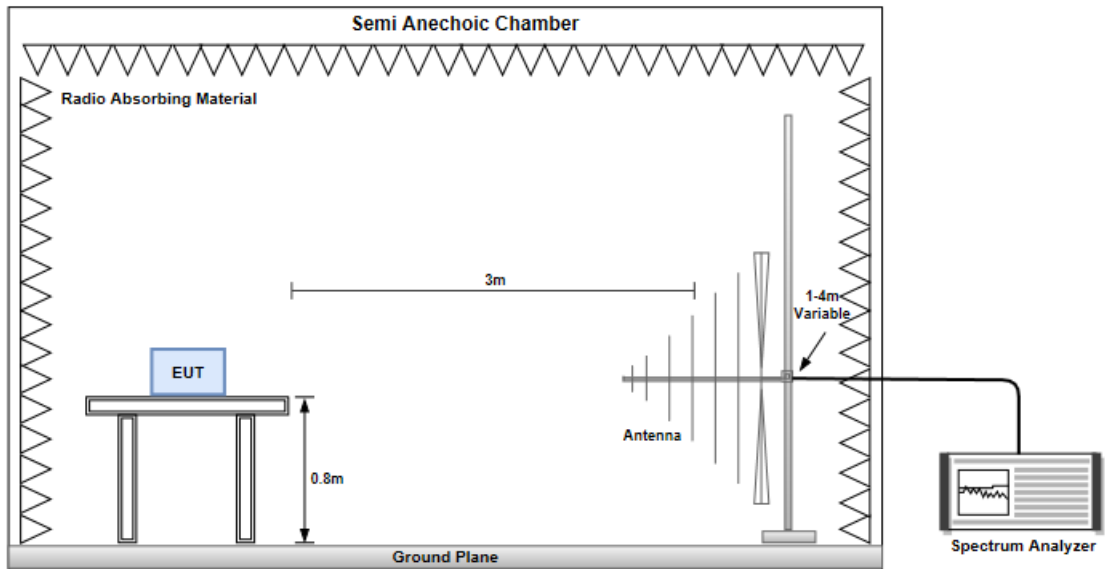

Radiated Emissions above 1 GHz

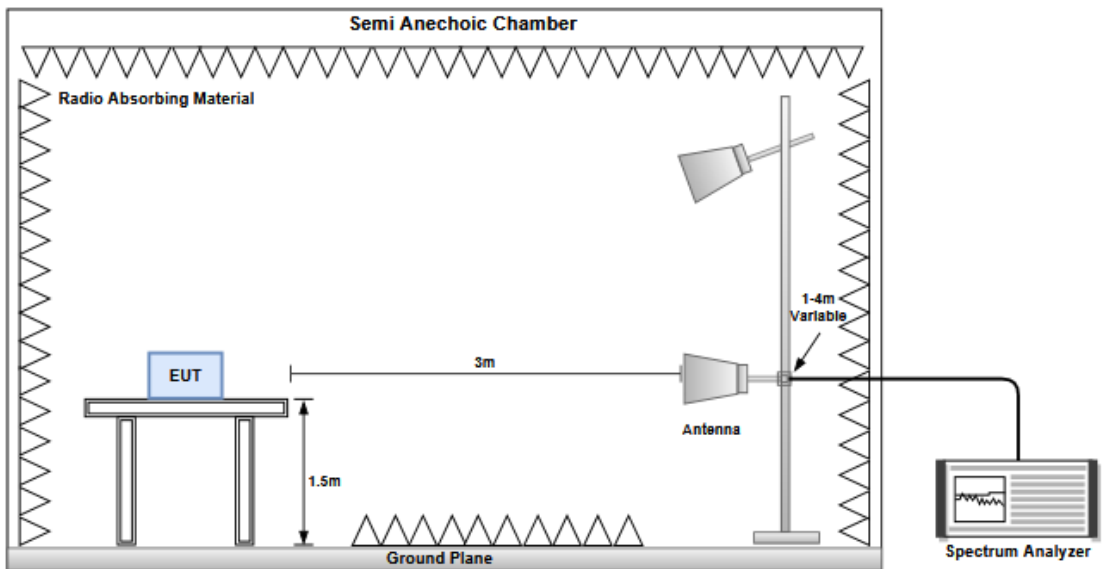

3.5.4 Transmitter Radiated Unwanted Emissions (Below 1GHz)

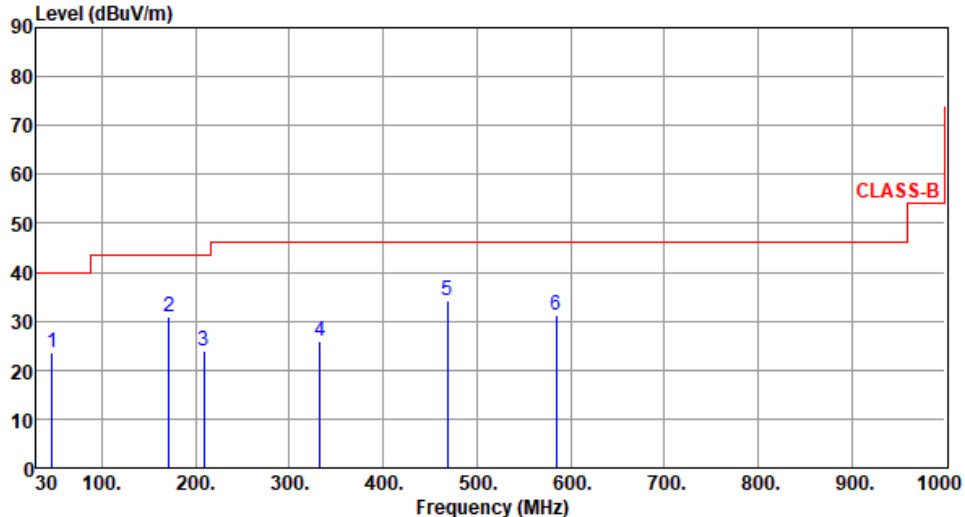
Modulation	HT40	Test Freq. (MHz)	2437						
Polarization	Horizontal								
Test By : Roger Lu Temperature(°C):22 Humidity(%):68									
 <p>The graph plots Level (dBuV/m) on the y-axis (0 to 90) against Frequency (MHz) on the x-axis (30 to 1000). A red line represents the CLASS-B limit, which is approximately 40 dBuV/m from 30 MHz to 100 MHz, 43 dBuV/m from 100 MHz to 200 MHz, and 46 dBuV/m from 200 MHz to 1000 MHz. Six blue vertical lines represent emission peaks labeled 1 through 6, with their respective frequencies and levels indicated in the table below.</p>									
	Freq. MHz	Emission level dBuV/m	Limit dBuV/m	Margin dB	SA reading dBuV	Factor dB/m	Remark	ANT High cm	Turn Table deg
1	46.49	23.42	40.00	-16.58	31.91	-8.49	Peak	---	---
2	171.62	30.99	43.50	-12.51	40.14	-9.15	Peak	---	---
3	208.48	23.98	43.50	-19.52	35.94	-11.96	Peak	---	---
4	332.64	25.82	46.00	-20.18	33.20	-7.38	Peak	---	---
5	468.44	34.36	46.00	-11.64	38.35	-3.99	Peak	---	---
6	584.84	31.15	46.00	-14.85	32.61	-1.46	Peak	---	---

Note 1: Emission Level (dBuV/m) = SA Reading (dBuV) + Factor* (dB/m)
*Factor includes antenna factor , cable loss and amplifier gain
Note 2: Margin (dB) = Emission level (dBuV/m) – Limit (dBuV/m).
Note 3: All spurious emissions below 30MHz are more than 20 dB below the limit.

Modulation	HT40	Test Freq. (MHz)	2437
Polarization	Vertical		

Test By :Roger Lu Temperature(°C):22 Humidity(%):68

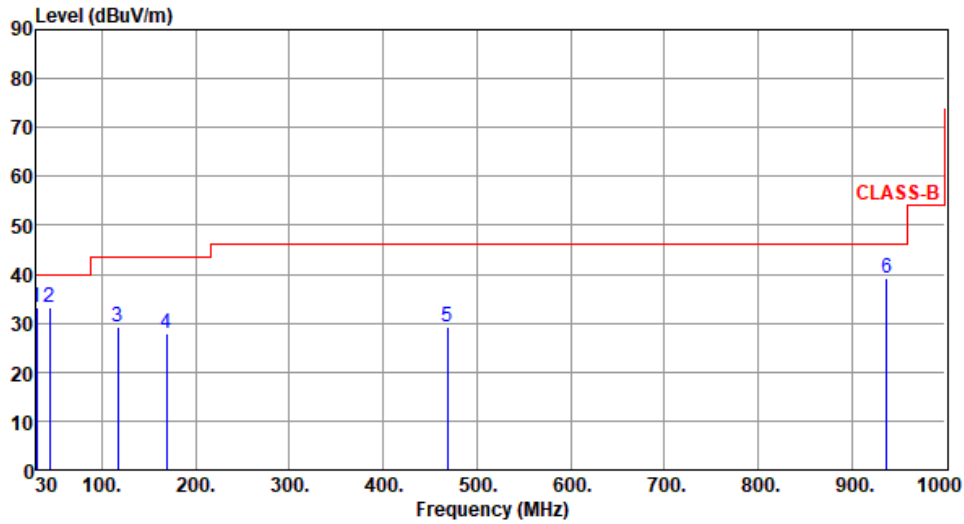

	Freq. MHz	Emission level dBuV/m	Limit dBuV/m	Margin dB	SA reading dBuV	Factor dB/m	Remark	ANT High cm	Turn Table deg
1	30.00	33.20	40.00	-6.80	43.14	-9.94	Peak	---	---
2	44.55	33.29	40.00	-6.71	41.77	-8.48	Peak	---	---
3	117.30	29.11	43.50	-14.39	40.02	-10.91	Peak	---	---
4	168.71	27.86	43.50	-15.64	36.82	-8.96	Peak	---	---
5	468.44	29.24	46.00	-16.76	33.23	-3.99	Peak	---	---
6	936.95	39.23	46.00	-6.77	34.99	4.24	Peak	---	---

Note 1: Emission Level (dBuV/m) = SA Reading (dBuV) + Factor* (dB/m)

*Factor includes antenna factor , cable loss and amplifier gain

Note 2: Margin (dB) = Emission level (dBuV/m) – Limit (dBuV/m).

Note 3: All spurious emissions below 30MHz are more than 20 dB below the limit.

3.5.5 Transmitter Radiated Unwanted Emissions (Above 1GHz) for 11b

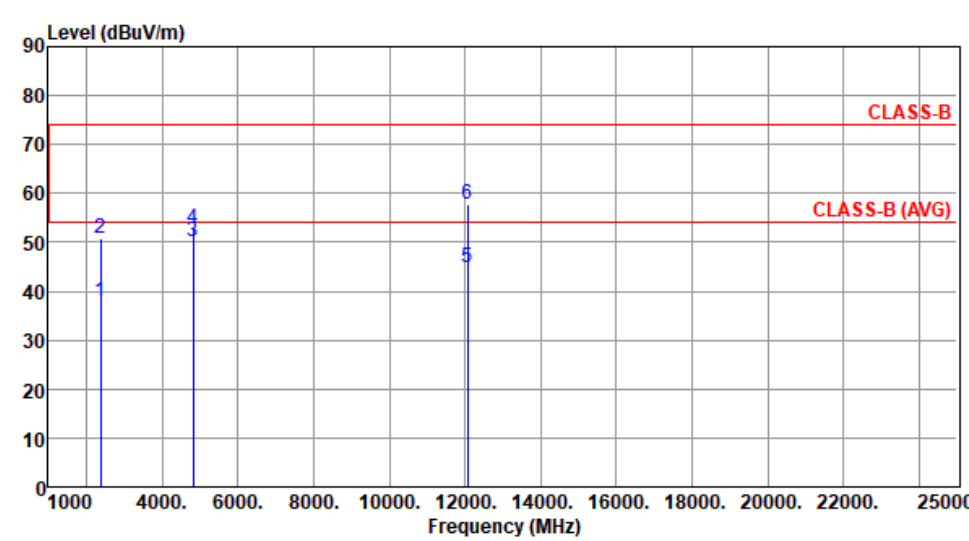
Modulation	11b	Test Freq. (MHz)	2412						
Polarization	Horizontal								
Test By : Roger Lu Temperature(°C):23 Humidity(%):68									
									
	Freq.	Emission level	Limit	Margin	SA reading	Factor	Remark	ANT High	Turn Table
	MHz	dBuV/m	dBuV/m	dB	dBuV	dB/m		cm	deg
1	2390.00	37.82	54.00	-16.18	40.83	-3.01	Average	106	246
2	2390.00	50.71	74.00	-23.29	53.72	-3.01	Peak	106	246
3	4824.00	49.99	54.00	-4.01	46.31	3.68	Average	233	209
4	4824.00	52.67	74.00	-21.33	48.99	3.68	Peak	233	209
5	12060.00	44.71	54.00	-9.29	31.12	13.59	Average	100	200
6	12060.00	57.68	74.00	-16.32	44.09	13.59	Peak	100	200
<p>Note 1: Emission Level (dBuV/m) = SA Reading (dBuV) + Factor* (dB/m) *Factor includes antenna factor , cable loss and amplifier gain Note 2: Margin (dB) = Emission level (dBuV/m) – Limit (dBuV/m).</p>									

Modulation	11b	Test Freq. (MHz)	2412
Polarization	Vertical		

Test By :Roger Lu Temperature(°C):23 Humidity(%):68

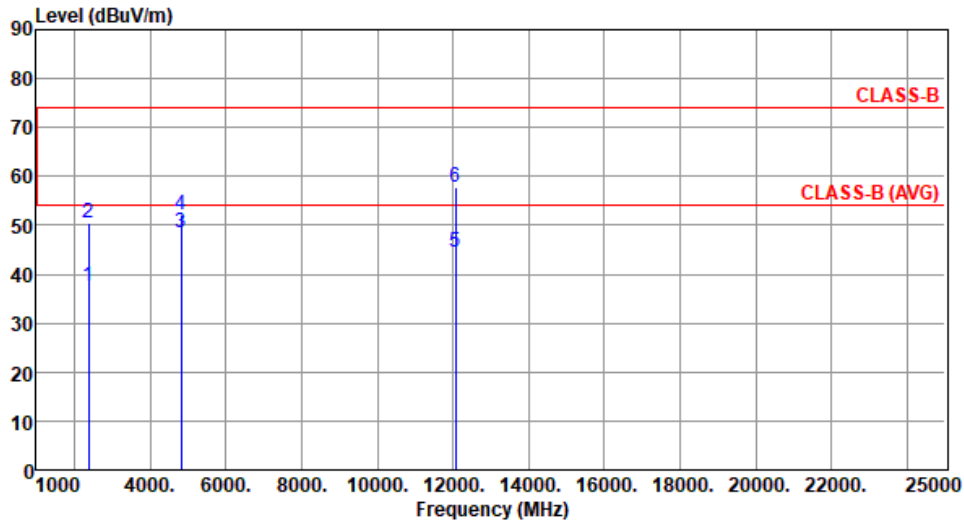

	Freq. MHz	Emission level dBuV/m	Limit dBuV/m	Margin dB	SA reading dBuV	Factor dB/m	Remark	ANT High cm	Turn Table deg
1	2390.00	37.40	54.00	-16.60	40.41	-3.01	Average	110	255
2	2390.00	50.51	74.00	-23.49	53.52	-3.01	Peak	110	255
3	4824.00	48.58	54.00	-5.42	44.90	3.68	Average	248	267
4	4824.00	52.24	74.00	-21.76	48.56	3.68	Peak	248	267
5	12060.00	44.58	54.00	-9.42	30.99	13.59	Average	100	150
6	12060.00	57.63	74.00	-16.37	44.04	13.59	Peak	100	150

Note 1: Emission Level (dBuV/m) = SA Reading (dBuV) + Factor* (dB/m)

*Factor includes antenna factor , cable loss and amplifier gain

Note 2: Margin (dB) = Emission level (dBuV/m) – Limit (dBuV/m).

Modulation	11b	Test Freq. (MHz)	2437
Polarization	Horizontal		

Test By :Roger Lu Temperature(°C):23 Humidity(%):68

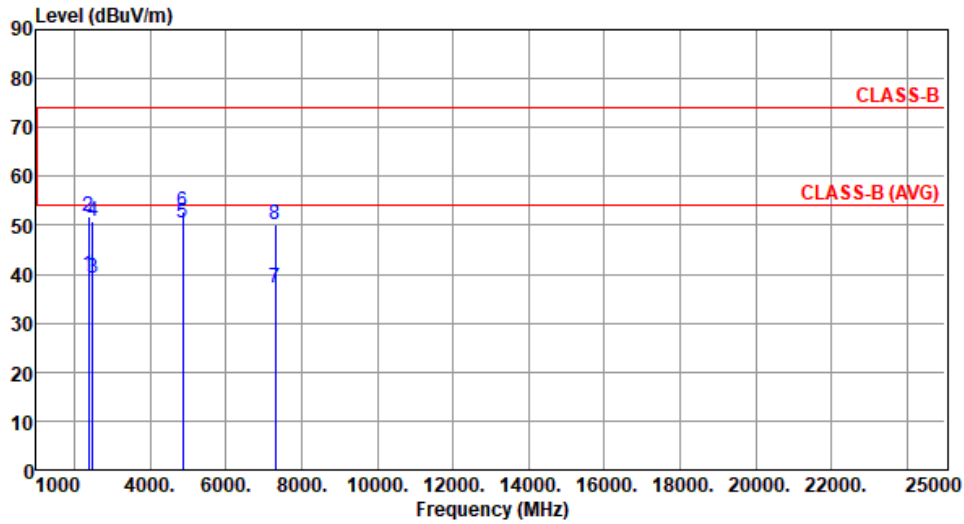

	Freq. MHz	Emission level dBuV/m	Limit dBuV/m	Margin dB	SA reading dBuV	Factor dB/m	Remark	ANT High cm	Turn Table deg
1	2390.00	39.86	54.00	-14.14	42.87	-3.01	Average	102	241
2	2390.00	51.88	74.00	-22.12	54.89	-3.01	Peak	102	241
3	2483.50	39.03	54.00	-14.97	41.98	-2.95	Average	102	241
4	2483.50	50.98	74.00	-23.02	53.93	-2.95	Peak	102	241
5	4874.00	50.47	54.00	-3.53	46.80	3.67	Average	163	210
6	4874.00	52.84	74.00	-21.16	49.17	3.67	Peak	163	210
7	7311.00	37.05	54.00	-16.95	28.08	8.97	Average	100	60
8	7311.00	50.05	74.00	-23.95	41.08	8.97	Peak	100	60

Note 1: Emission Level (dBuV/m) = SA Reading (dBuV) + Factor* (dB/m)

*Factor includes antenna factor , cable loss and amplifier gain

Note 2: Margin (dB) = Emission level (dBuV/m) – Limit (dBuV/m).

Modulation	11b	Test Freq. (MHz)	2437
Polarization	Vertical		

Test By :Roger Lu Temperature(°C):23 Humidity(%):68

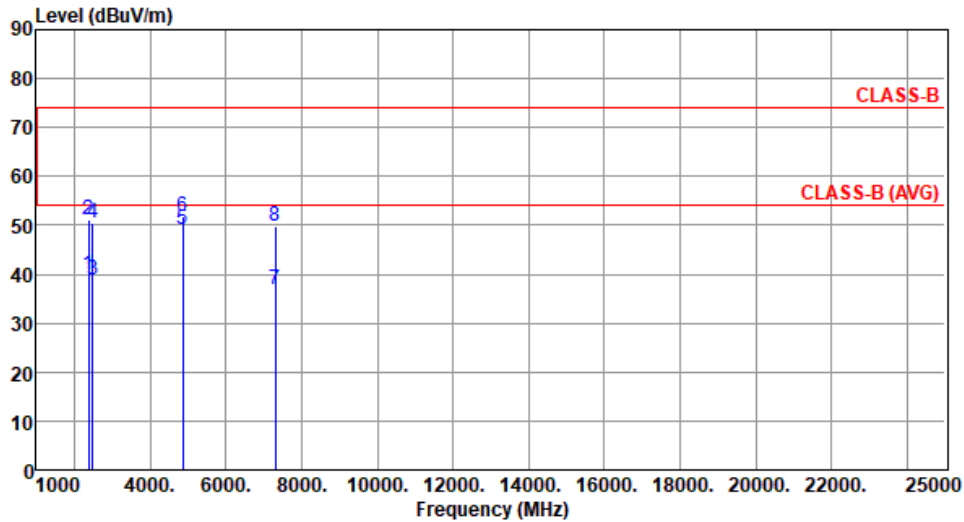

	Freq. MHz	Emission level dBuV/m	Limit dBuV/m	Margin dB	SA reading dBuV	Factor dB/m	Remark	ANT High cm	Turn Table deg
1	2390.00	39.99	54.00	-14.01	43.00	-3.01	Average	108	280
2	2390.00	51.06	74.00	-22.94	54.07	-3.01	Peak	108	280
3	2483.50	38.71	54.00	-15.29	41.66	-2.95	Average	108	280
4	2483.50	50.65	74.00	-23.35	53.60	-2.95	Peak	108	280
5	4874.00	49.30	54.00	-4.70	45.63	3.67	Average	172	159
6	4874.00	51.94	74.00	-22.06	48.27	3.67	Peak	172	159
7	7311.00	36.93	54.00	-17.07	27.96	8.97	Average	100	55
8	7311.00	49.92	74.00	-24.08	40.95	8.97	Peak	100	55

Note 1: Emission Level (dBuV/m) = SA Reading (dBuV) + Factor* (dB/m)

*Factor includes antenna factor , cable loss and amplifier gain

Note 2: Margin (dB) = Emission level (dBuV/m) – Limit (dBuV/m).

Modulation	11b	Test Freq. (MHz)	2462
Polarization	Horizontal		

Test By :Roger Lu Temperature(°C):23 Humidity(%):68

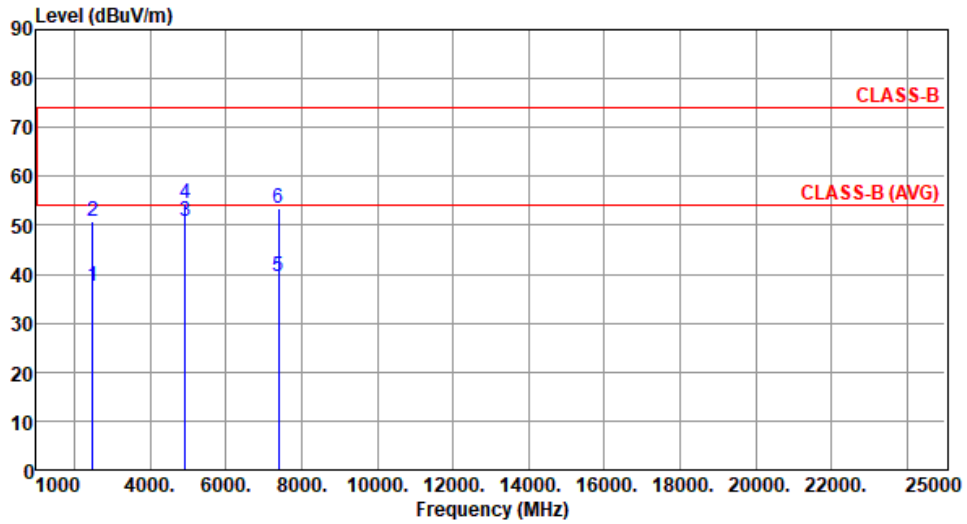

	Freq. MHz	Emission level dBuV/m	Limit dBuV/m	Margin dB	SA reading dBuV	Factor dB/m	Remark	ANT High cm	Turn Table deg
1	2483.50	37.63	54.00	-16.37	40.58	-2.95	Average	104	245
2	2483.50	50.87	74.00	-23.13	53.82	-2.95	Peak	104	245
3	4924.00	50.88	54.00	-3.12	47.28	3.60	Average	165	221
4	4924.00	54.62	74.00	-19.38	51.02	3.60	Peak	165	221
5	7386.00	39.43	54.00	-14.57	30.48	8.95	Average	100	230
6	7386.00	53.46	74.00	-20.54	44.51	8.95	Peak	100	230

Note 1: Emission Level (dBuV/m) = SA Reading (dBuV) + Factor* (dB/m)

*Factor includes antenna factor , cable loss and amplifier gain

Note 2: Margin (dB) = Emission level (dBuV/m) – Limit (dBuV/m).

Modulation	11b	Test Freq. (MHz)	2462
Polarization	Vertical		

Test By :Roger Lu Temperature(°C):23 Humidity(%):68

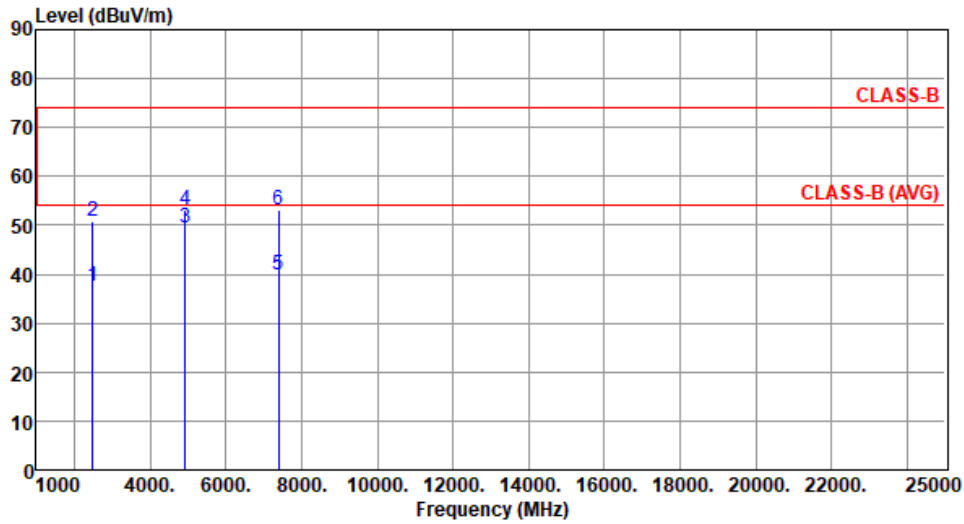

	Freq. MHz	Emission level dBUV/m	Limit dBUV/m	Margin dB	SA reading dBUV	Factor dB/m	Remark	ANT High cm	Turn Table deg
1	2483.50	37.43	54.00	-16.57	40.38	-2.95	Average	100	270
2	2483.50	50.73	74.00	-23.27	53.68	-2.95	Peak	100	270
3	4924.00	49.50	54.00	-4.50	45.90	3.60	Average	174	160
4	4924.00	52.99	74.00	-21.01	49.39	3.60	Peak	174	160
5	7386.00	39.98	54.00	-14.02	31.03	8.95	Average	100	165
6	7386.00	53.02	74.00	-20.98	44.07	8.95	Peak	100	165

Note 1: Emission Level (dBUV/m) = SA Reading (dBUV) + Factor* (dB/m)

*Factor includes antenna factor , cable loss and amplifier gain

Note 2: Margin (dB) = Emission level (dBUV/m) – Limit (dBUV/m).

3.5.6 Transmitter Radiated Unwanted Emissions (Above 1GHz) for 11g

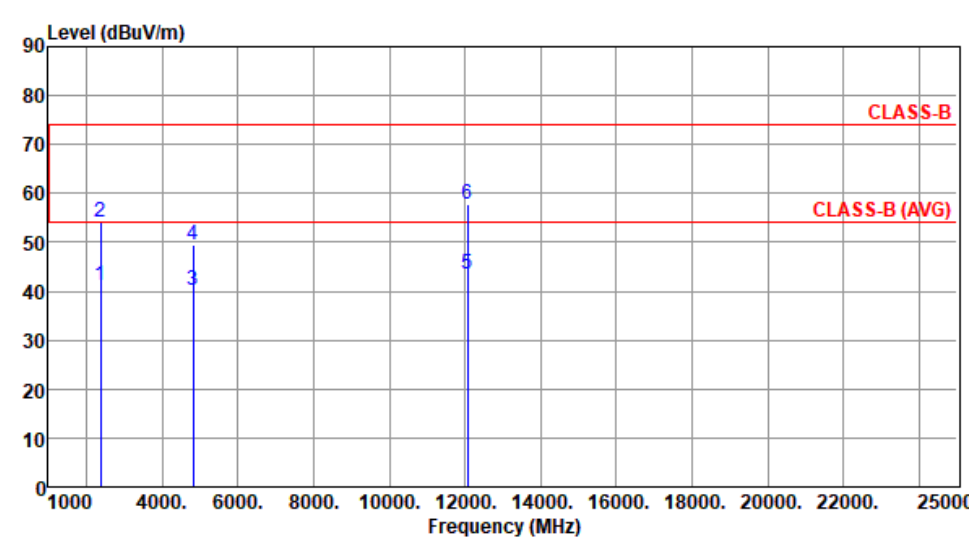
Modulation	11g	Test Freq. (MHz)	2412						
Polarization	Horizontal								
Test By : Roger Lu Temperature(°C):23 Humidity(%):68									
									
	Freq.	Emission level	Limit	Margin	SA reading	Factor	Remark	ANT High	Turn Table
	MHz	dBuV/m	dBuV/m	dB	dBuV	dB/m		cm	deg
1	2390.00	41.05	54.00	-12.95	44.06	-3.01	Average	138	241
2	2390.00	54.17	74.00	-19.83	57.18	-3.01	Peak	138	241
3	4824.00	40.09	54.00	-13.91	36.41	3.68	Average	153	217
4	4824.00	49.37	74.00	-24.63	45.69	3.68	Peak	153	217
5	12060.00	43.65	54.00	-10.35	30.06	13.59	Average	100	215
6	12060.00	57.66	74.00	-16.34	44.07	13.59	Peak	100	215

Note 1: Emission Level (dBuV/m) = SA Reading (dBuV) + Factor* (dB/m)
*Factor includes antenna factor , cable loss and amplifier gain
Note 2: Margin (dB) = Emission level (dBuV/m) – Limit (dBuV/m).

Modulation	11g	Test Freq. (MHz)	2412
Polarization	Vertical		

Test By :Roger Lu Temperature(°C):23 Humidity(%):68

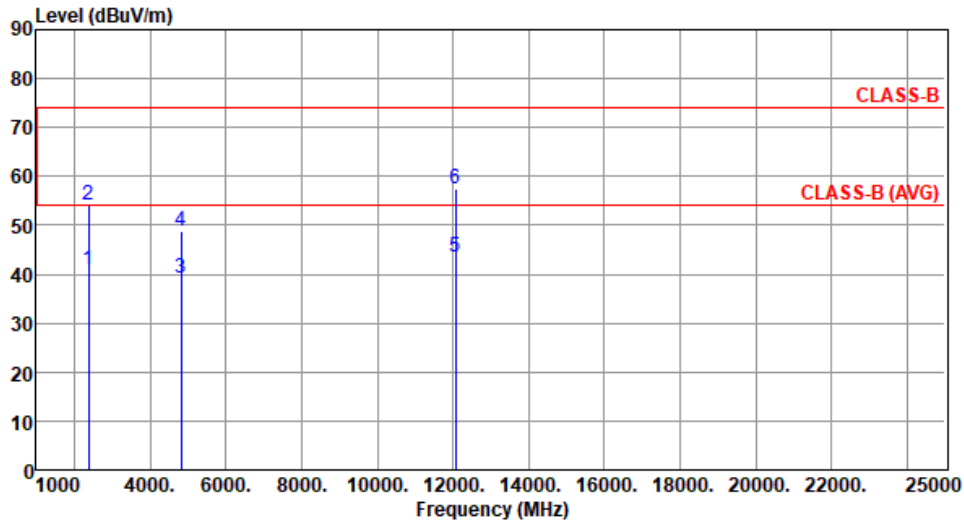

	Freq. MHz	Emission level dBuV/m	Limit dBuV/m	Margin dB	SA reading dBuV	Factor dB/m	Remark	ANT High cm	Turn Table deg
1	2390.00	40.82	54.00	-13.18	43.83	-3.01	Average	103	278
2	2390.00	54.03	74.00	-19.97	57.04	-3.01	Peak	103	278
3	4824.00	39.18	54.00	-14.82	35.50	3.68	Average	180	158
4	4824.00	48.97	74.00	-25.03	45.29	3.68	Peak	180	158
5	12060.00	43.48	54.00	-10.52	29.89	13.59	Average	100	160
6	12060.00	57.53	74.00	-16.47	43.94	13.59	Peak	100	160

Note 1: Emission Level (dBuV/m) = SA Reading (dBuV) + Factor* (dB/m)

*Factor includes antenna factor , cable loss and amplifier gain

Note 2: Margin (dB) = Emission level (dBuV/m) – Limit (dBuV/m).

Modulation	11g	Test Freq. (MHz)	2437
Polarization	Horizontal		

Test By :Roger Lu Temperature(°C):23 Humidity(%):68

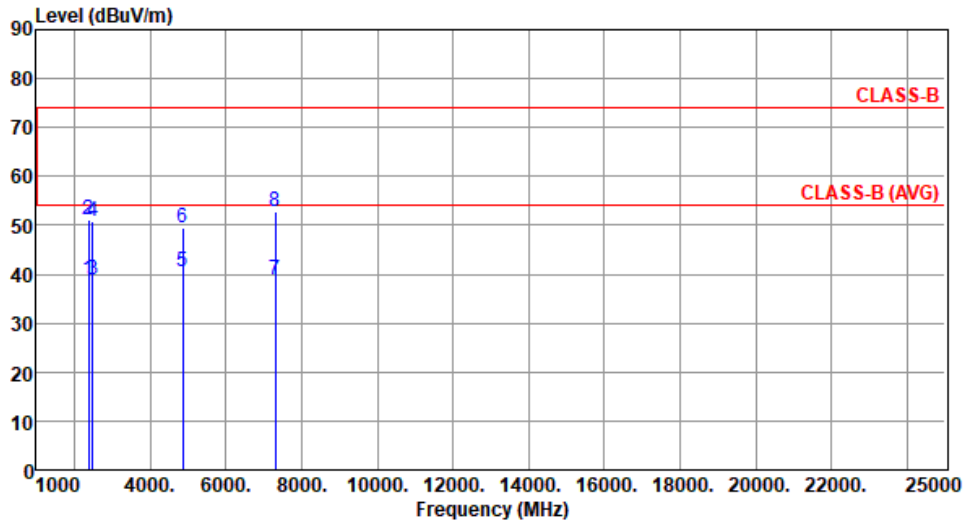

	Freq. MHz	Emission level dBuV/m	Limit dBuV/m	Margin dB	SA reading dBuV	Factor dB/m	Remark	ANT High cm	Turn Table deg
1	2390.00	38.96	54.00	-15.04	41.97	-3.01	Average	142	244
2	2390.00	51.15	74.00	-22.85	54.16	-3.01	Peak	142	244
3	2483.50	38.94	54.00	-15.06	41.89	-2.95	Average	142	244
4	2483.50	50.97	74.00	-23.03	53.92	-2.95	Peak	142	244
5	4874.00	40.46	54.00	-13.54	36.79	3.67	Average	166	204
6	4874.00	49.43	74.00	-24.57	45.76	3.67	Peak	166	204
7	7311.00	39.01	54.00	-14.99	30.04	8.97	Average	100	200
8	7311.00	52.89	74.00	-21.11	43.92	8.97	Peak	100	200

Note 1: Emission Level (dBuV/m) = SA Reading (dBuV) + Factor* (dB/m)

*Factor includes antenna factor , cable loss and amplifier gain

Note 2: Margin (dB) = Emission level (dBuV/m) – Limit (dBuV/m).

Modulation	11g	Test Freq. (MHz)	2437
Polarization	Vertical		

Test By :Roger Lu Temperature(°C):23 Humidity(%):68

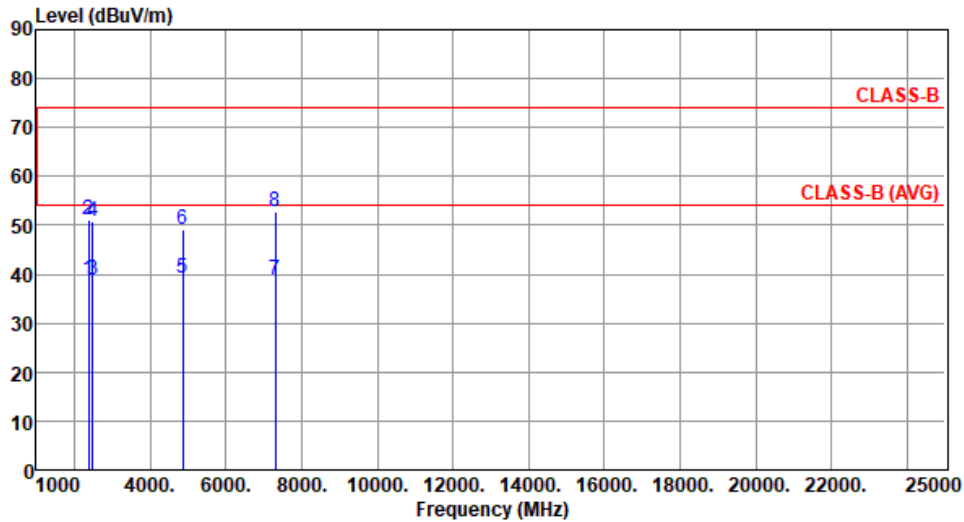

	Freq. MHz	Emission level dBuV/m	Limit dBuV/m	Margin dB	SA reading dBuV	Factor dB/m	Remark	ANT High cm	Turn Table deg
1	2390.00	38.83	54.00	-15.17	41.84	-3.01	Average	100	275
2	2390.00	51.03	74.00	-22.97	54.04	-3.01	Peak	100	275
3	2483.50	38.89	54.00	-15.11	41.84	-2.95	Average	100	275
4	2483.50	50.86	74.00	-23.14	53.81	-2.95	Peak	100	275
5	4874.00	39.27	54.00	-14.73	35.60	3.67	Average	184	158
6	4874.00	49.06	74.00	-24.94	45.39	3.67	Peak	184	158
7	7311.00	39.00	54.00	-15.00	30.03	8.97	Average	100	165
8	7311.00	52.95	74.00	-21.05	43.98	8.97	Peak	100	165

Note 1: Emission Level (dBuV/m) = SA Reading (dBuV) + Factor* (dB/m)

*Factor includes antenna factor , cable loss and amplifier gain

Note 2: Margin (dB) = Emission level (dBuV/m) – Limit (dBuV/m).

Modulation	11g	Test Freq. (MHz)	2462
Polarization	Horizontal		

Test By :Roger Lu Temperature(°C):23 Humidity(%):68

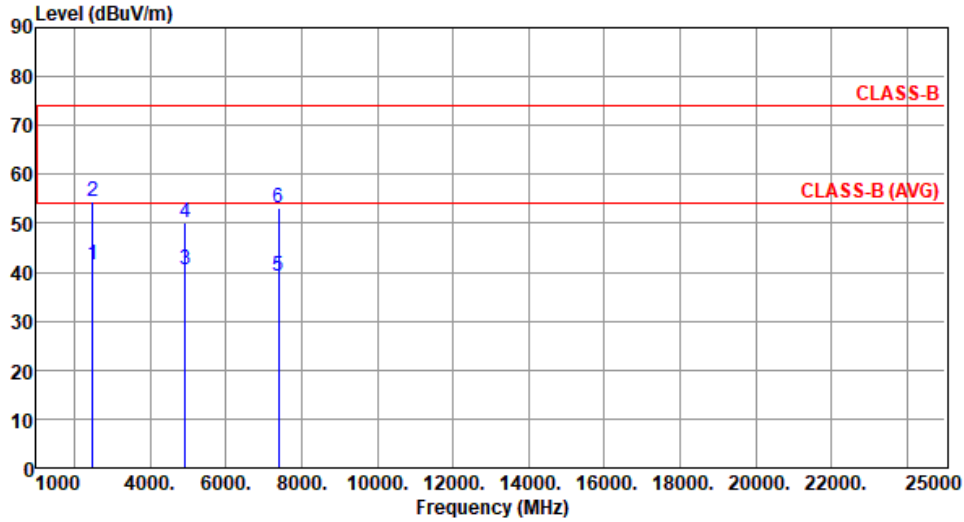

	Freq. MHz	Emission level dBuV/m	Limit dBuV/m	Margin dB	SA reading dBuV	Factor dB/m	Remark	ANT High cm	Turn Table deg
1	2483.50	41.37	54.00	-12.63	44.32	-2.95	Average	115	239
2	2483.50	54.54	74.00	-19.46	57.49	-2.95	Peak	115	239
3	4924.00	40.47	54.00	-13.53	36.87	3.60	Average	157	203
4	4924.00	50.10	74.00	-23.90	46.50	3.60	Peak	157	203
5	7386.00	39.13	54.00	-14.87	30.18	8.95	Average	100	210
6	7386.00	53.15	74.00	-20.85	44.20	8.95	Peak	100	210

Note 1: Emission Level (dBuV/m) = SA Reading (dBuV) + Factor* (dB/m)
 *Factor includes antenna factor , cable loss and amplifier gain
 Note 2: Margin (dB) = Emission level (dBuV/m) – Limit (dBuV/m).

Modulation	11g	Test Freq. (MHz)	2462
Polarization	Vertical		

Test By :Roger Lu Temperature(°C):23 Humidity(%):68

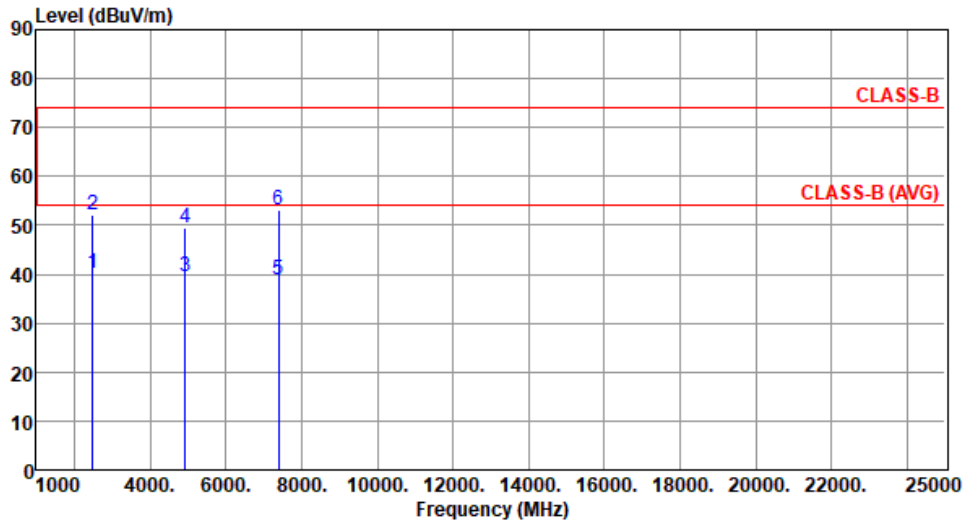

	Freq. MHz	Emission level dBuV/m	Limit dBuV/m	Margin dB	SA reading dBuV	Factor dB/m	Remark	ANT High cm	Turn Table deg
1	2483.50	40.20	54.00	-13.80	43.15	-2.95	Average	104	280
2	2483.50	51.99	74.00	-22.01	54.94	-2.95	Peak	104	280
3	4924.00	39.45	54.00	-14.55	35.85	3.60	Average	180	155
4	4924.00	49.47	74.00	-24.53	45.87	3.60	Peak	180	155
5	7386.00	39.02	54.00	-14.98	30.07	8.95	Average	100	149
6	7386.00	52.99	74.00	-21.01	44.04	8.95	Peak	100	149

Note 1: Emission Level (dBuV/m) = SA Reading (dBuV) + Factor* (dB/m)

*Factor includes antenna factor , cable loss and amplifier gain

Note 2: Margin (dB) = Emission level (dBuV/m) – Limit (dBuV/m).

3.5.7 Transmitter Radiated Unwanted Emissions (Above 1GHz) for HT20

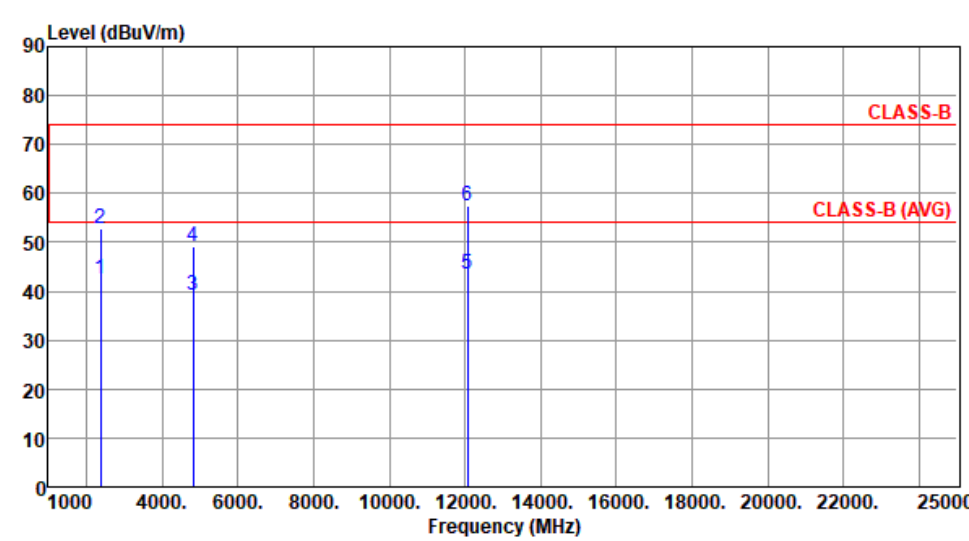
Modulation	HT20	Test Freq. (MHz)	2412						
Polarization	Horizontal								
Test By : Roger Lu Temperature(°C):23 Humidity(%):68									
									
	Freq.	Emission level	Limit	Margin	SA reading	Factor	Remark	ANT High	Turn Table
	MHz	dBuV/m	dBuV/m	dB	dBuV	dB/m		cm	deg
1	2390.00	42.38	54.00	-11.62	45.39	-3.01	Average	117	245
2	2390.00	52.89	74.00	-21.11	55.90	-3.01	Peak	117	245
3	4824.00	39.07	54.00	-14.93	35.39	3.68	Average	156	208
4	4824.00	49.06	74.00	-24.94	45.38	3.68	Peak	156	208
5	12060.00	43.53	54.00	-10.47	29.94	13.59	Average	100	200
6	12060.00	57.48	74.00	-16.52	43.89	13.59	Peak	100	200

Note 1: Emission Level (dBuV/m) = SA Reading (dBuV) + Factor* (dB/m)
*Factor includes antenna factor , cable loss and amplifier gain
Note 2: Margin (dB) = Emission level (dBuV/m) – Limit (dBuV/m).

Modulation	HT20	Test Freq. (MHz)	2412
Polarization	Vertical		

Test By :Roger Lu Temperature(°C):23 Humidity(%):68

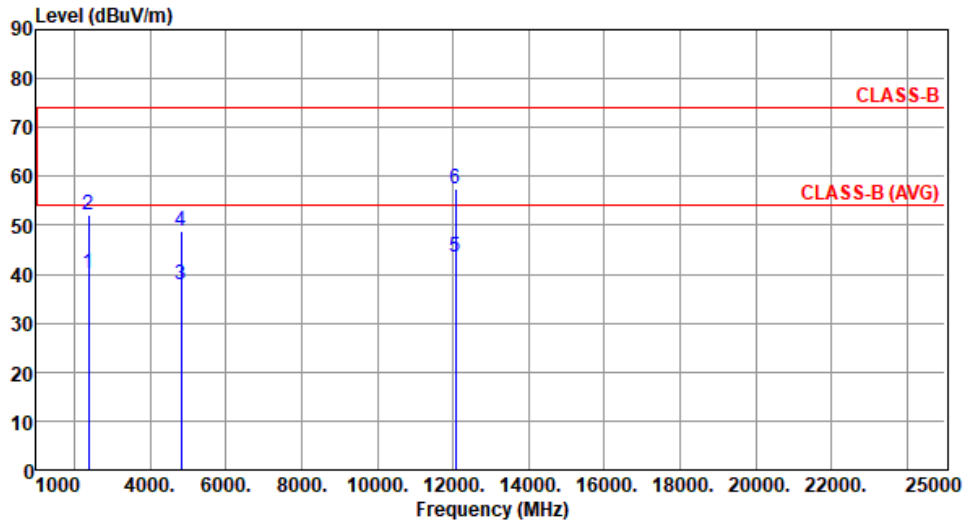

	Freq. MHz	Emission level dBuV/m	Limit dBuV/m	Margin dB	SA reading dBuV	Factor dB/m	Remark	ANT High cm	Turn Table deg
1	2390.00	40.03	54.00	-13.97	43.04	-3.01	Average	136	277
2	2390.00	52.15	74.00	-21.85	55.16	-3.01	Peak	136	277
3	4824.00	37.94	54.00	-16.06	34.26	3.68	Average	174	154
4	4824.00	48.87	74.00	-25.13	45.19	3.68	Peak	174	154
5	12060.00	43.42	54.00	-10.58	29.83	13.59	Average	100	145
6	12060.00	57.42	74.00	-16.58	43.83	13.59	Peak	100	145

Note 1: Emission Level (dBuV/m) = SA Reading (dBuV) + Factor* (dB/m)

*Factor includes antenna factor , cable loss and amplifier gain

Note 2: Margin (dB) = Emission level (dBuV/m) – Limit (dBuV/m).

Modulation	HT20	Test Freq. (MHz)	2437
Polarization	Horizontal		

Test By :Roger Lu Temperature(°C):23 Humidity(%):68

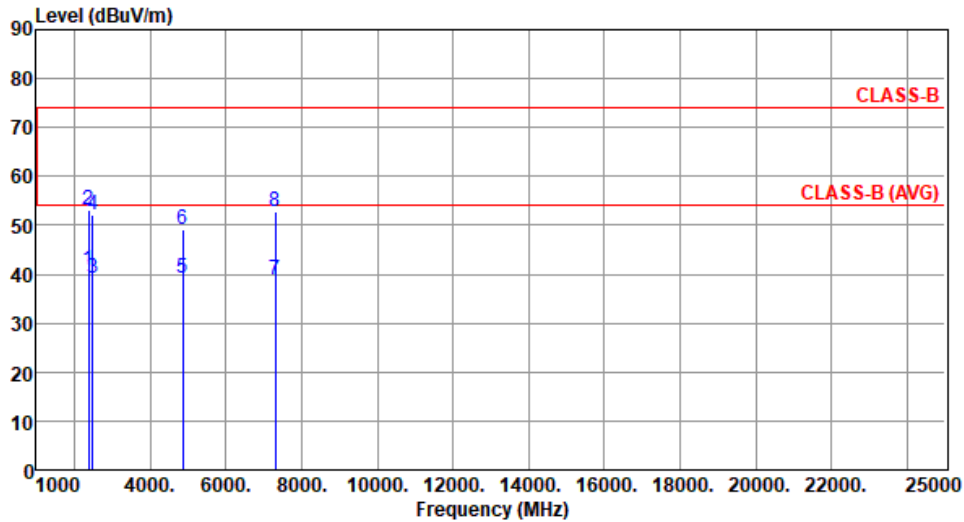

	Freq. MHz	Emission level dBuV/m	Limit dBuV/m	Margin dB	SA reading dBuV	Factor dB/m	Remark	ANT High cm	Turn Table deg
1	2390.00	40.86	54.00	-13.14	43.87	-3.01	Average	123	241
2	2390.00	53.13	74.00	-20.87	56.14	-3.01	Peak	123	241
3	2483.50	39.10	54.00	-14.90	42.05	-2.95	Average	123	241
4	2483.50	51.98	74.00	-22.02	54.93	-2.95	Peak	123	241
5	4874.00	39.24	54.00	-14.76	35.57	3.67	Average	171	212
6	4874.00	49.18	74.00	-24.82	45.51	3.67	Peak	171	212
7	7311.00	38.93	54.00	-15.07	29.96	8.97	Average	100	215
8	7311.00	52.91	74.00	-21.09	43.94	8.97	Peak	100	215

Note 1: Emission Level (dBuV/m) = SA Reading (dBuV) + Factor* (dB/m)

*Factor includes antenna factor , cable loss and amplifier gain

Note 2: Margin (dB) = Emission level (dBuV/m) – Limit (dBuV/m).

Modulation	HT20	Test Freq. (MHz)	2437
Polarization	Vertical		

Test By :Roger Lu Temperature(°C):23 Humidity(%):68

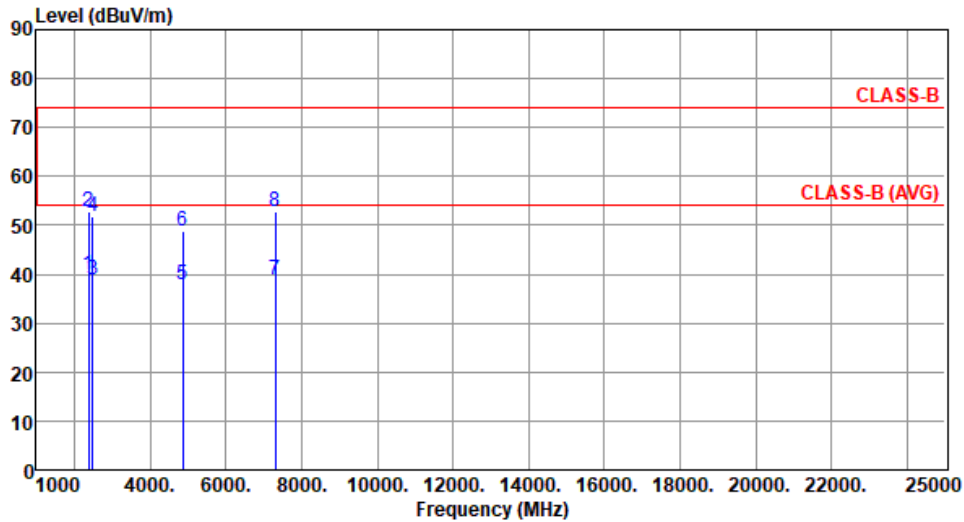

	Freq. MHz	Emission level dBuV/m	Limit dBuV/m	Margin dB	SA reading dBuV	Factor dB/m	Remark	ANT High cm	Turn Table deg
1	2390.00	39.94	54.00	-14.06	42.95	-3.01	Average	115	286
2	2390.00	52.86	74.00	-21.14	55.87	-3.01	Peak	115	286
3	2483.50	38.95	54.00	-15.05	41.90	-2.95	Average	115	286
4	2483.50	51.76	74.00	-22.24	54.71	-2.95	Peak	115	286
5	4874.00	37.99	54.00	-16.01	34.32	3.67	Average	170	159
6	4874.00	48.96	74.00	-25.04	45.29	3.67	Peak	170	159
7	7311.00	38.72	54.00	-15.28	29.75	8.97	Average	100	169
8	7311.00	52.70	74.00	-21.30	43.73	8.97	Peak	100	169

Note 1: Emission Level (dBuV/m) = SA Reading (dBuV) + Factor* (dB/m)

*Factor includes antenna factor , cable loss and amplifier gain

Note 2: Margin (dB) = Emission level (dBuV/m) – Limit (dBuV/m).

Modulation	HT20	Test Freq. (MHz)	2462
Polarization	Horizontal		

Test By :Roger Lu Temperature(°C):23 Humidity(%):68

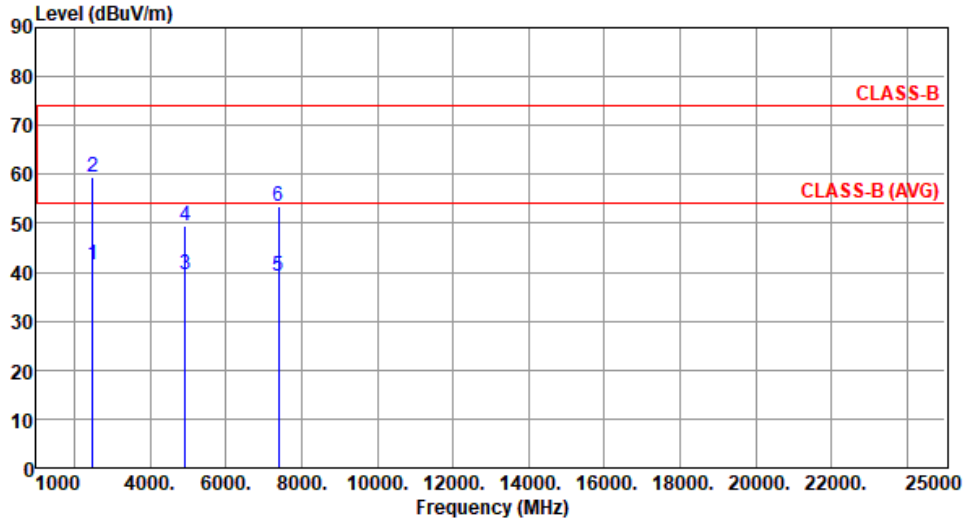

	Freq. MHz	Emission level dBuV/m	Limit dBuV/m	Margin dB	SA reading dBuV	Factor dB/m	Remark	ANT High cm	Turn Table deg
1	2483.50	41.43	54.00	-12.57	44.38	-2.95	Average	114	239
2	2483.50	59.29	74.00	-14.71	62.24	-2.95	Peak	114	239
3	4924.00	39.46	54.00	-14.54	35.86	3.60	Average	176	208
4	4924.00	49.53	74.00	-24.47	45.93	3.60	Peak	176	208
5	7386.00	39.14	54.00	-14.86	30.19	8.95	Average	100	201
6	7386.00	53.35	74.00	-20.65	44.40	8.95	Peak	100	201

Note 1: Emission Level (dBuV/m) = SA Reading (dBuV) + Factor* (dB/m)
 *Factor includes antenna factor , cable loss and amplifier gain
 Note 2: Margin (dB) = Emission level (dBuV/m) – Limit (dBuV/m).

Modulation	HT20	Test Freq. (MHz)	2462
Polarization	Vertical		

Test By :Roger Lu Temperature(°C):23 Humidity(%):68

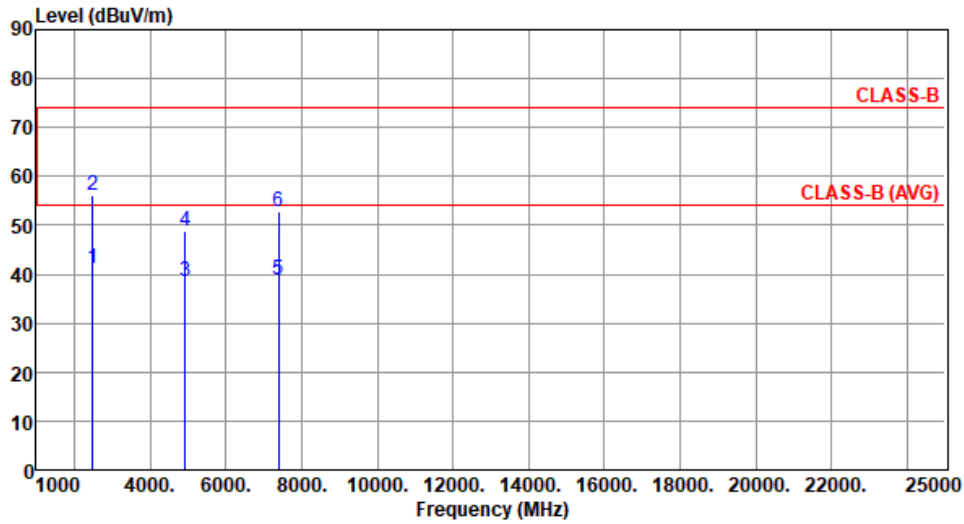

	Freq. MHz	Emission level dBuV/m	Limit dBuV/m	Margin dB	SA reading dBuV	Factor dB/m	Remark	ANT High cm	Turn Table deg
1	2483.50	41.19	54.00	-12.81	44.14	-2.95	Average	119	271
2	2483.50	56.17	74.00	-17.83	59.12	-2.95	Peak	119	271
3	4924.00	38.41	54.00	-15.59	34.81	3.60	Average	174	156
4	4924.00	48.93	74.00	-25.07	45.33	3.60	Peak	174	156
5	7386.00	38.82	54.00	-15.18	29.87	8.95	Average	100	163
6	7386.00	52.92	74.00	-21.08	43.97	8.95	Peak	100	163

Note 1: Emission Level (dBuV/m) = SA Reading (dBuV) + Factor* (dB/m)

*Factor includes antenna factor , cable loss and amplifier gain

Note 2: Margin (dB) = Emission level (dBuV/m) – Limit (dBuV/m).

3.5.8 Transmitter Radiated Unwanted Emissions (Above 1GHz) for HT40

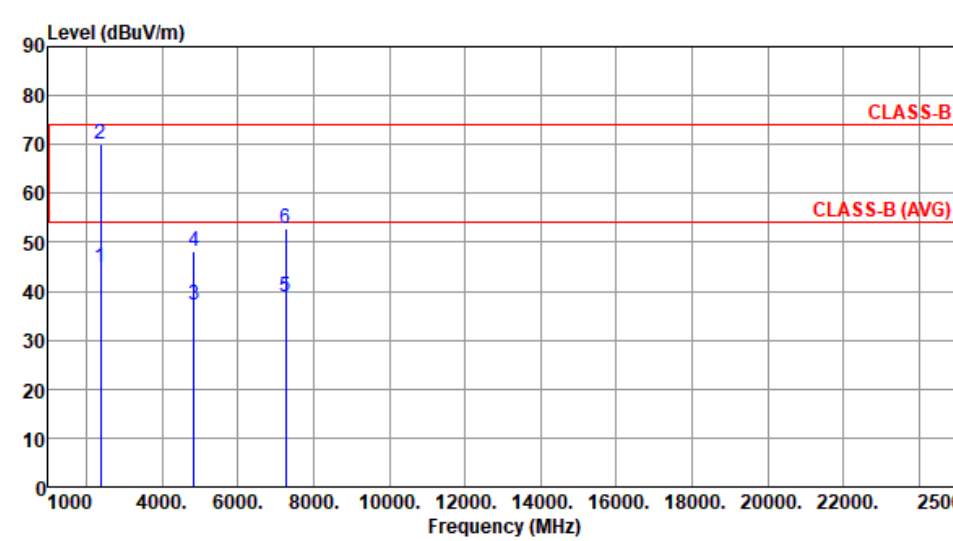
Modulation	HT40	Test Freq. (MHz)	2422						
Polarization	Horizontal								
Test By : Roger Lu Temperature(°C):23 Humidity(%):68									
									
	Freq.	Emission level	Limit	Margin	SA reading	Factor	Remark	ANT High	Turn Table
	MHz	dBuV/m	dBuV/m	dB	dBuV	dB/m		cm	deg
1	2390.00	44.99	54.00	-9.01	48.00	-3.01	Average	121	241
2	2390.00	69.93	74.00	-4.07	72.94	-3.01	Peak	121	241
3	4844.00	37.17	54.00	-16.83	33.47	3.70	Average	150	200
4	4844.00	48.22	74.00	-25.78	44.52	3.70	Peak	150	200
5	7266.00	38.85	54.00	-15.15	29.94	8.91	Average	100	205
6	7266.00	52.90	74.00	-21.10	43.99	8.91	Peak	100	205

Note 1: Emission Level (dBuV/m) = SA Reading (dBuV) + Factor* (dB/m)
*Factor includes antenna factor , cable loss and amplifier gain
Note 2: Margin (dB) = Emission level (dBuV/m) – Limit (dBuV/m).

Modulation	HT40	Test Freq. (MHz)	2422
Polarization	Vertical		

Test By :Roger Lu Temperature(°C):23 Humidity(%):68

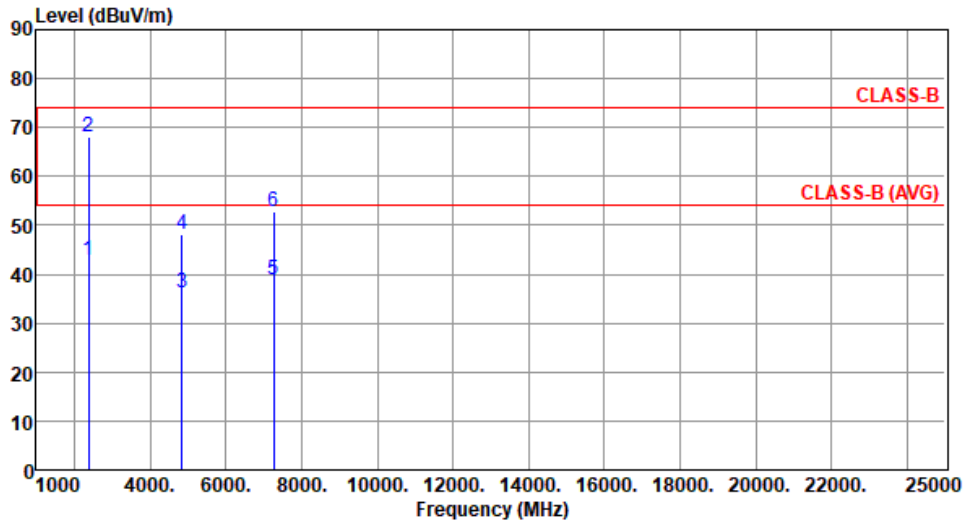

	Freq. MHz	Emission level dBuV/m	Limit dBuV/m	Margin dB	SA reading dBuV	Factor dB/m	Remark	ANT High cm	Turn Table deg
1	2390.00	42.83	54.00	-11.17	45.84	-3.01	Average	118	290
2	2390.00	68.03	74.00	-5.97	71.04	-3.01	Peak	118	290
3	4844.00	36.08	54.00	-17.92	32.38	3.70	Average	100	160
4	4844.00	47.99	74.00	-26.01	44.29	3.70	Peak	100	160
5	7266.00	38.75	54.00	-15.25	29.84	8.91	Average	100	155
6	7266.00	52.73	74.00	-21.27	43.82	8.91	Peak	100	155

Note 1: Emission Level (dBuV/m) = SA Reading (dBuV) + Factor* (dB/m)
 *Factor includes antenna factor , cable loss and amplifier gain
 Note 2: Margin (dB) = Emission level (dBuV/m) – Limit (dBuV/m).

Modulation	HT40	Test Freq. (MHz)	2437
Polarization	Horizontal		

Test By :Roger Lu Temperature(°C):23 Humidity(%):68

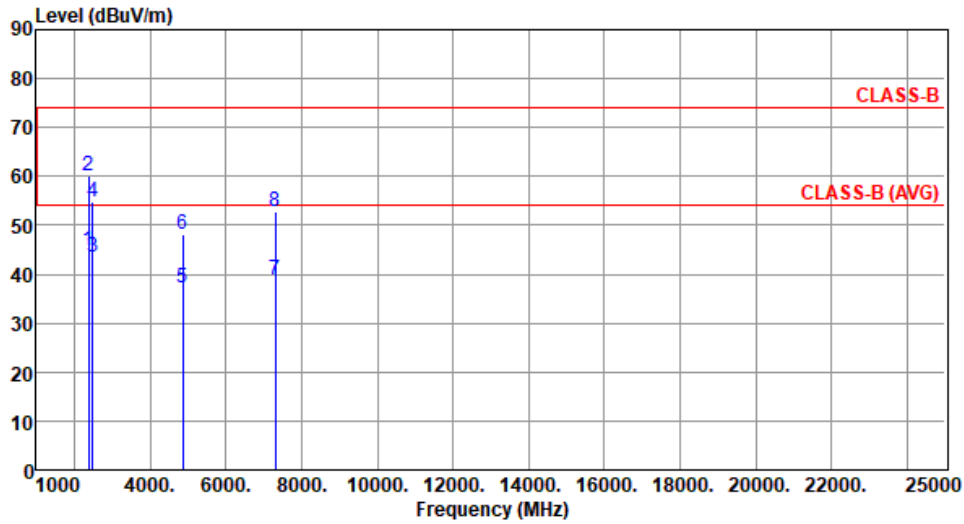

	Freq. MHz	Emission level dBuV/m	Limit dBuV/m	Margin dB	SA reading dBuV	Factor dB/m	Remark	ANT High cm	Turn Table deg
1	2390.00	44.94	54.00	-9.06	47.95	-3.01	Average	122	241
2	2390.00	60.08	74.00	-13.92	63.09	-3.01	Peak	122	241
3	2483.50	43.41	54.00	-10.59	46.36	-2.95	Average	122	241
4	2483.50	54.74	74.00	-19.26	57.69	-2.95	Peak	122	241
5	4874.00	37.18	54.00	-16.82	33.51	3.67	Average	158	207
6	4874.00	48.18	74.00	-25.82	44.51	3.67	Peak	158	207
7	7311.00	38.75	54.00	-15.25	29.78	8.97	Average	100	204
8	7311.00	52.77	74.00	-21.23	43.80	8.97	Peak	100	204

Note 1: Emission Level (dBuV/m) = SA Reading (dBuV) + Factor* (dB/m)

*Factor includes antenna factor , cable loss and amplifier gain

Note 2: Margin (dB) = Emission level (dBuV/m) – Limit (dBuV/m).

Modulation	HT40	Test Freq. (MHz)	2437
Polarization	Vertical		

Test By :Roger Lu Temperature(°C):23 Humidity(%):68

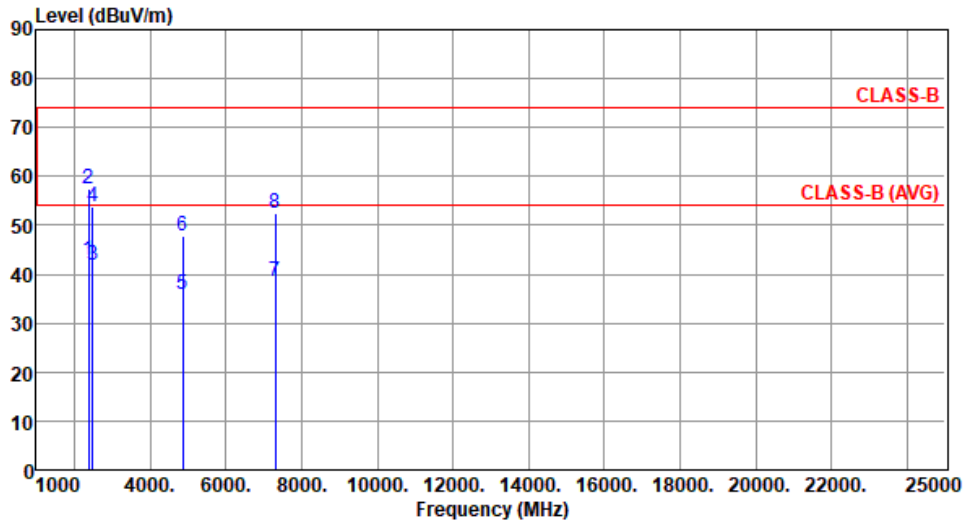

	Freq. MHz	Emission level dBuV/m	Limit dBuV/m	Margin dB	SA reading dBuV	Factor dB/m	Remark	ANT High cm	Turn Table deg
1	2390.00	42.99	54.00	-11.01	46.00	-3.01	Average	110	274
2	2390.00	57.42	74.00	-16.58	60.43	-3.01	Peak	110	274
3	2483.50	41.70	54.00	-12.30	44.65	-2.95	Average	110	274
4	2483.50	53.78	74.00	-20.22	56.73	-2.95	Peak	110	274
5	4874.00	35.76	54.00	-18.24	32.09	3.67	Average	158	155
6	4874.00	47.98	74.00	-26.02	44.31	3.67	Peak	158	155
7	7311.00	38.56	54.00	-15.44	29.59	8.97	Average	100	150
8	7311.00	52.53	74.00	-21.47	43.56	8.97	Peak	100	150

Note 1: Emission Level (dBuV/m) = SA Reading (dBuV) + Factor* (dB/m)

*Factor includes antenna factor , cable loss and amplifier gain

Note 2: Margin (dB) = Emission level (dBuV/m) – Limit (dBuV/m).

Modulation	HT40	Test Freq. (MHz)	2452
Polarization	Horizontal		

Test By :Roger Lu Temperature(°C):23 Humidity(%):68

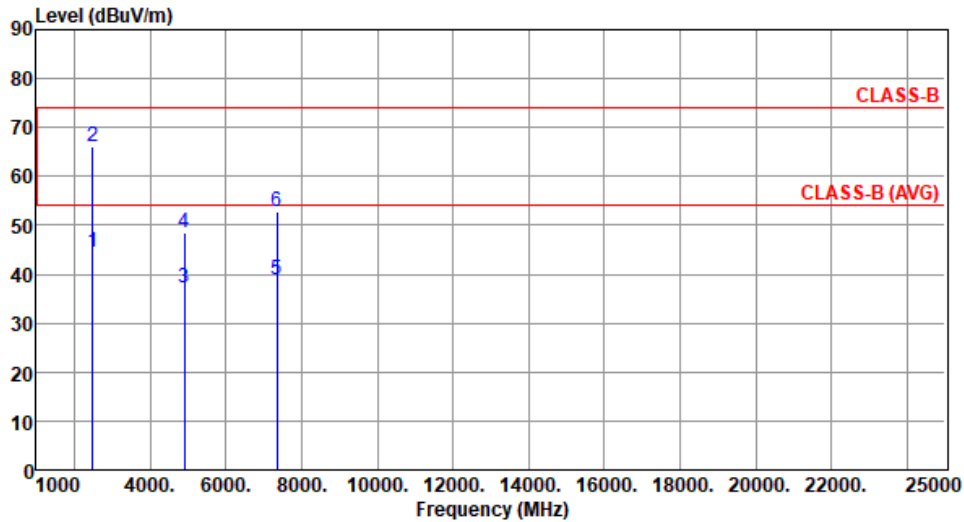

	Freq. MHz	Emission level dBuV/m	Limit dBuV/m	Margin dB	SA reading dBuV	Factor dB/m	Remark	ANT High cm	Turn Table deg
1	2483.50	44.40	54.00	-9.60	47.35	-2.95	Average	111	242
2	2483.50	66.09	74.00	-7.91	69.04	-2.95	Peak	111	242
3	4904.00	37.30	54.00	-16.70	33.67	3.63	Average	158	208
4	4904.00	48.45	74.00	-25.55	44.82	3.63	Peak	158	208
5	7356.00	38.81	54.00	-15.19	29.85	8.96	Average	100	219
6	7356.00	52.83	74.00	-21.17	43.87	8.96	Peak	100	219

Note 1: Emission Level (dBuV/m) = SA Reading (dBuV) + Factor* (dB/m)

*Factor includes antenna factor , cable loss and amplifier gain

Note 2: Margin (dB) = Emission level (dBuV/m) – Limit (dBuV/m).

Modulation	HT40	Test Freq. (MHz)	2452
Polarization	Vertical		

Test By :Roger Lu Temperature(°C):23 Humidity(%) :68

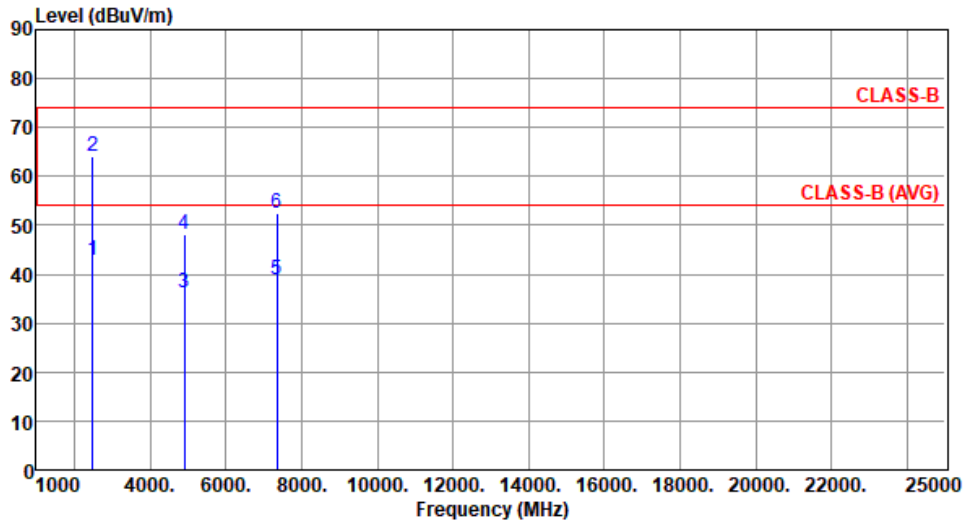

	Freq. MHz	Emission level dBuV/m	Limit dBuV/m	Margin dB	SA reading dBuV	Factor dB/m	Remark	ANT High cm	Turn Table deg
1	2483.50	42.87	54.00	-11.13	45.82	-2.95	Average	119	286
2	2483.50	64.19	74.00	-9.81	67.14	-2.95	Peak	119	286
3	4904.00	36.27	54.00	-17.73	32.64	3.63	Average	170	160
4	4904.00	48.05	74.00	-25.95	44.42	3.63	Peak	170	160
5	7356.00	38.76	54.00	-15.24	29.80	8.96	Average	100	169
6	7356.00	52.58	74.00	-21.42	43.62	8.96	Peak	100	169

Note 1: Emission Level (dBuV/m) = SA Reading (dBuV) + Factor* (dB/m)

*Factor includes antenna factor , cable loss and amplifier gain

Note 2: Margin (dB) = Emission level (dBuV/m) – Limit (dBuV/m).

3.6 Emissions in Non-Restricted Frequency Bands

3.6.1 Emissions in Non-Restricted Frequency Bands Limit

Peak power in any 100 kHz bandwidth outside of the authorized frequency band shall be attenuated by at least 20 dB relative to the maximum in-band peak PSD level in 100 kHz.

3.6.2 Test Procedures

Reference level measurement

1. Set RBW=100kHz, VBW = 300kHz , Detector = Peak, Sweep time = Auto
2. Trace = max hold , Allow Trace to fully stabilize
3. Use the peak marker function to determine the maximum PSD level

Emission level measurement

1. Set RBW=100kHz, VBW = 300kHz , Detector = Peak, Sweep time = Auto
2. Trace = max hold , Allow Trace to fully stabilize
3. Scan Frequency range is up to 25GHz
4. Use the peak marker function to determine the maximum amplitude level

3.6.3 Test Setup

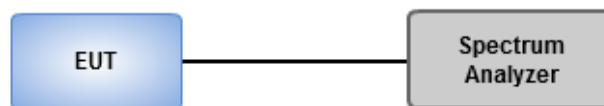

3.6.4 Unwanted Emissions into Non-Restricted Frequency Bands

Ambient Condition	22°C / 65%	Tested By	Roger Lu
-------------------	------------	-----------	----------



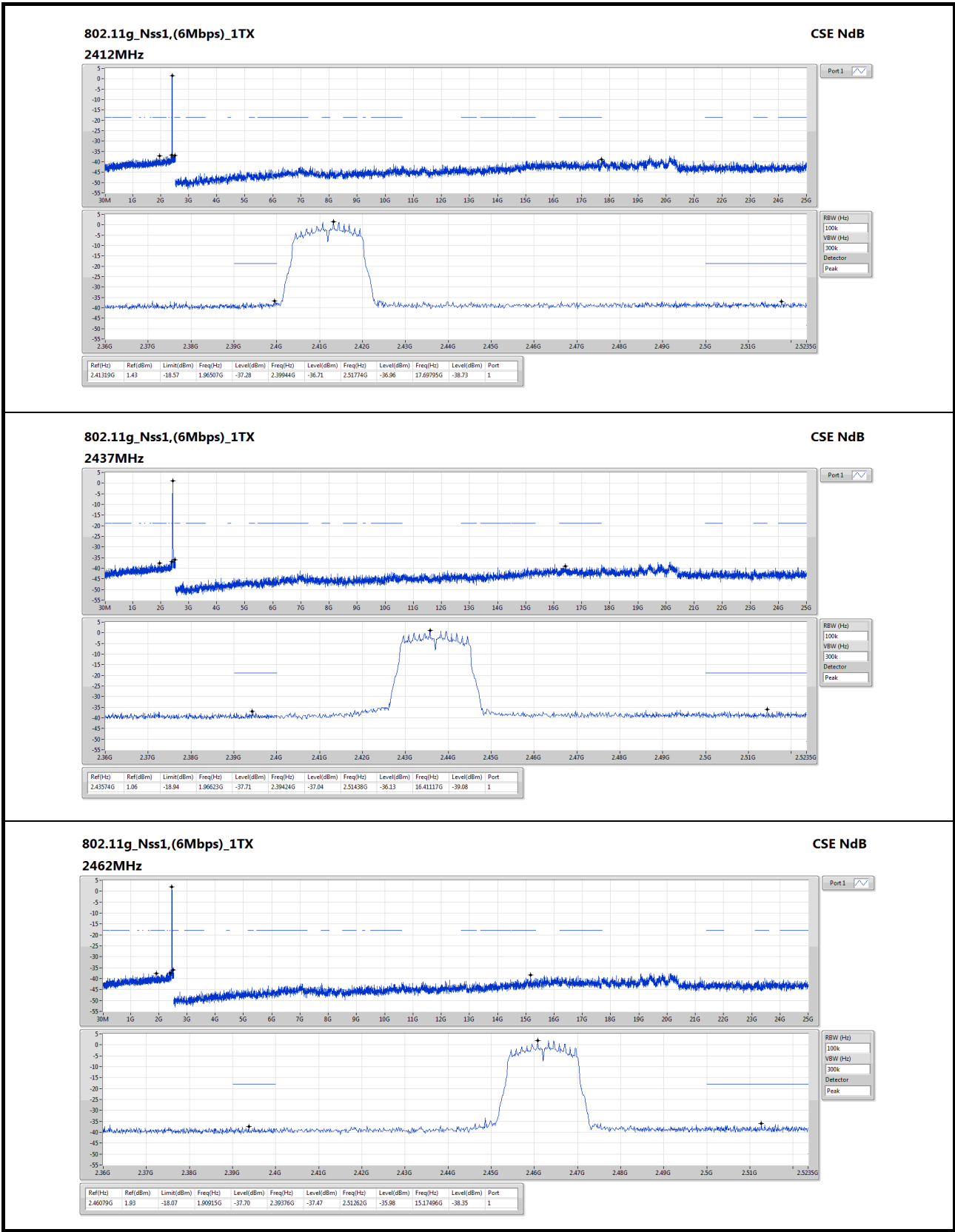

802.11n HT20_Nss1,(MCS0)_1TX
2412MHz

CSE NdB

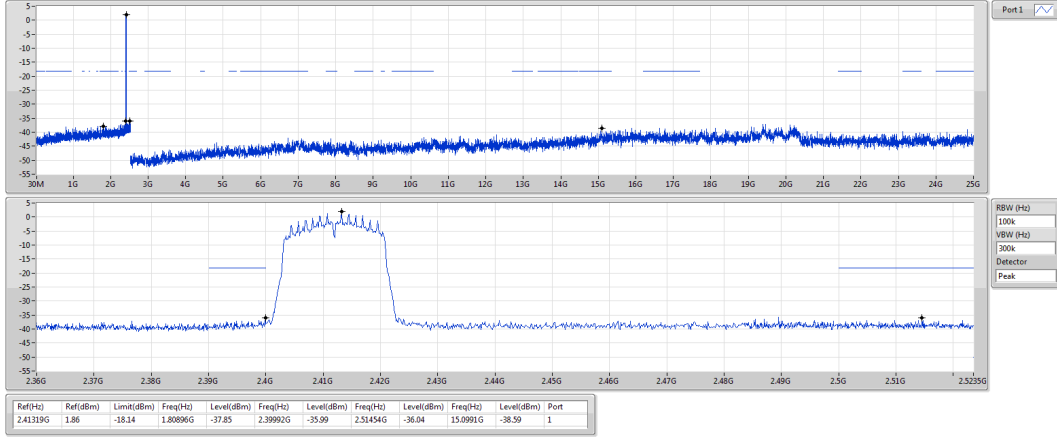

802.11n HT20_Nss1,(MCS0)_1TX
2437MHz

CSE NdB

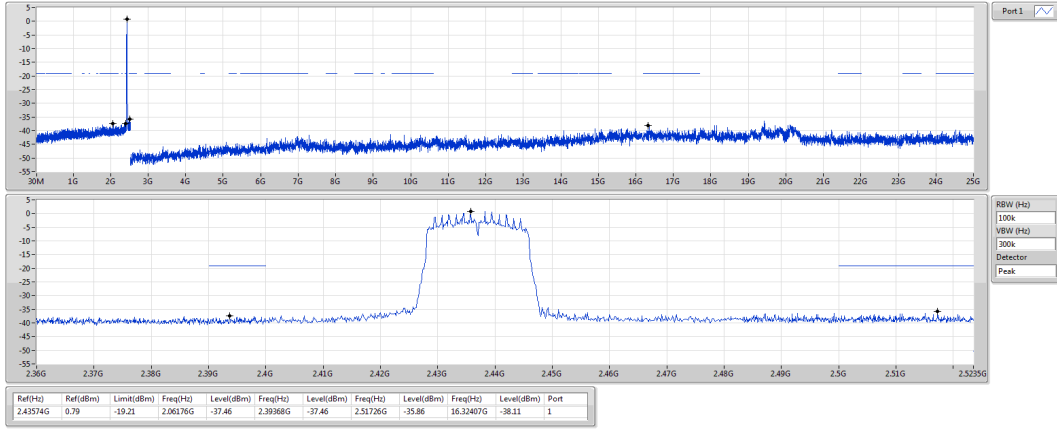

802.11n HT20_Nss1,(MCS0)_1TX
2462MHz

CSE NdB

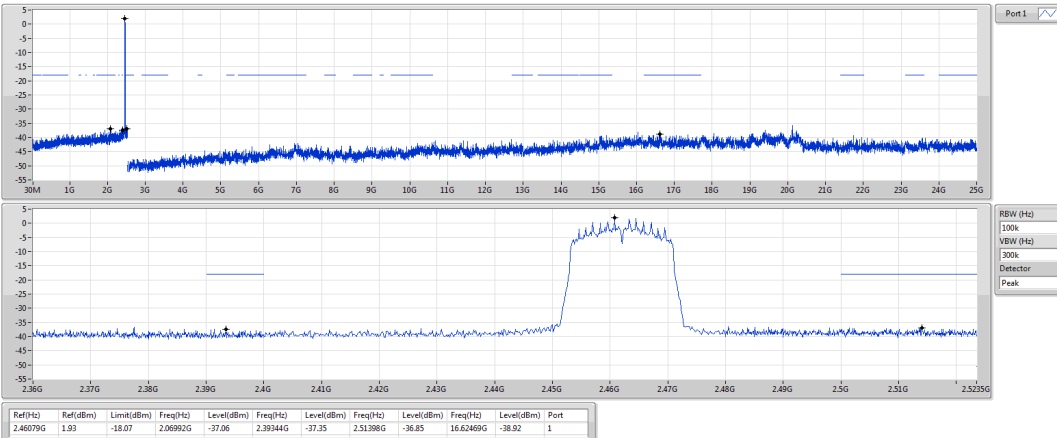

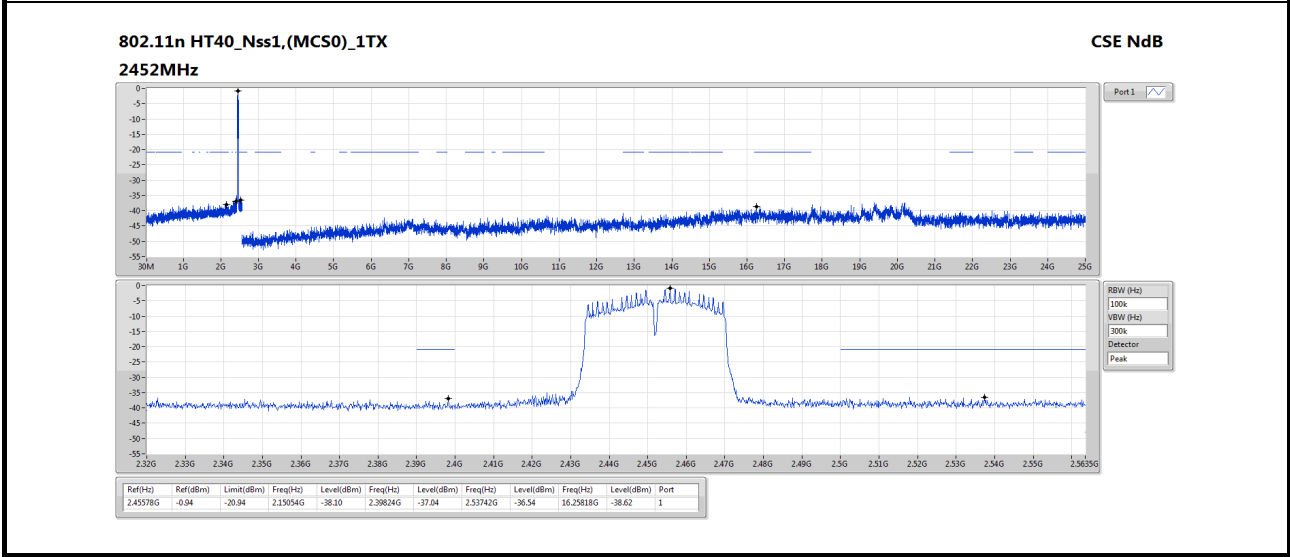
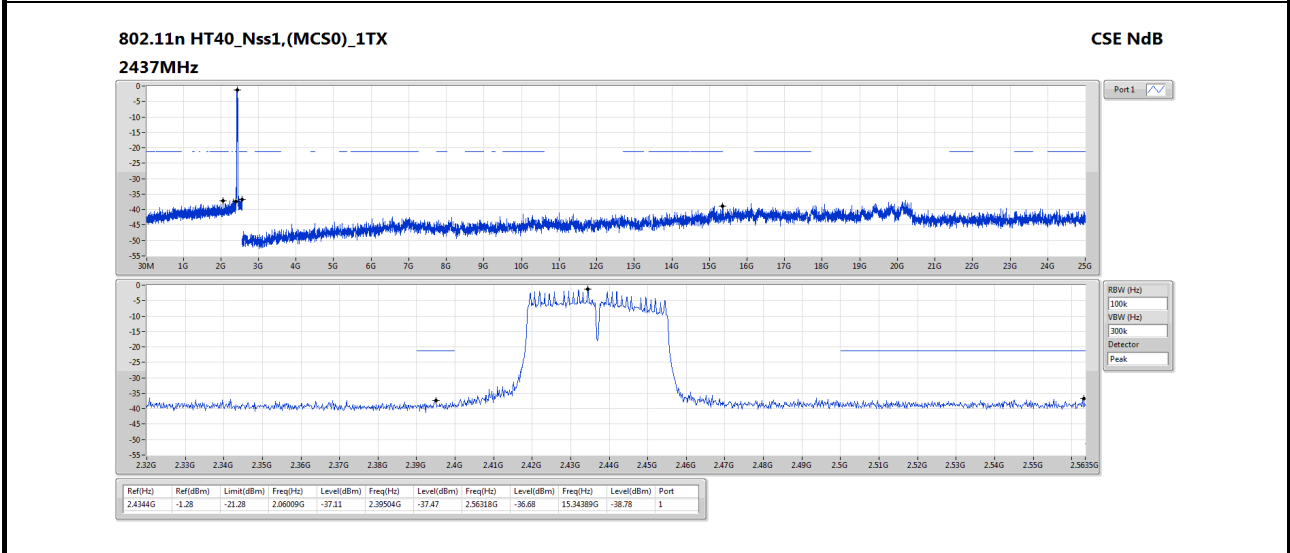
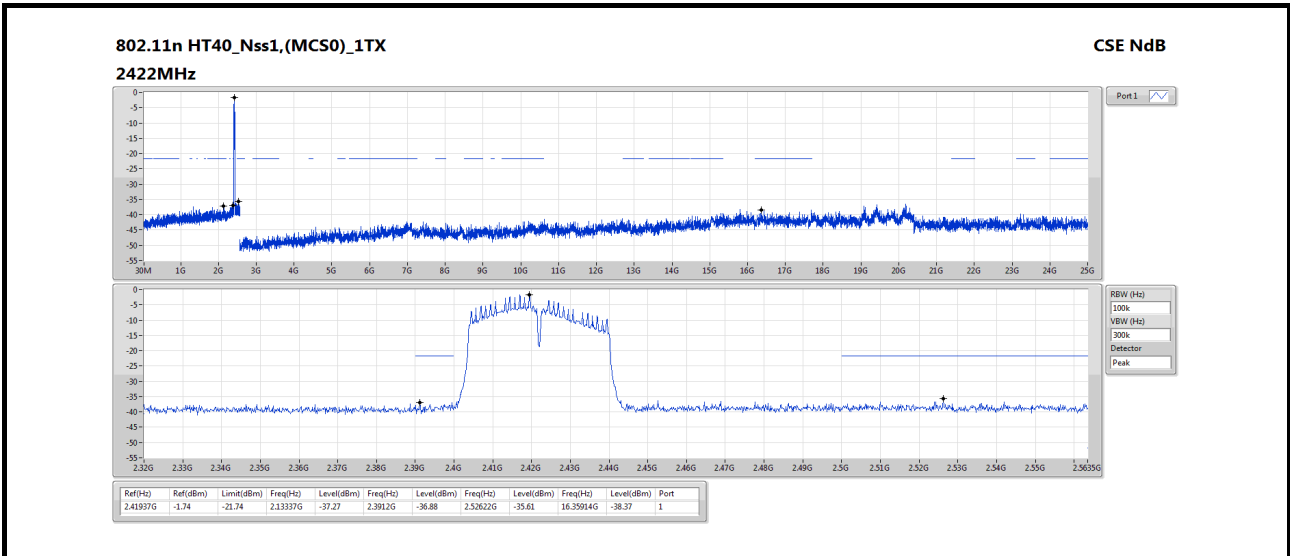

4 Test laboratory information

Established in 2012, ICC provides foremost EMC & RF Testing and advisory consultation services by our skilled engineers and technicians. Our services employ a wide variety of advanced edge test equipment and one of the widest certification extents in the business.

International Certification Corporation (EMC and Wireless Communication Laboratory), it is our definitive objective is to institute long term, trust-based associations with our clients. The expectation we set up with our clients is based on outstanding service, practical expertise and devotion to a certified value structure. Our passion is to grant our clients with best EMC / RF services by oriented knowledgeable and accommodating staff.

Our Test sites are located at Linkou District and Kwei Shan District. Location map can be found on our website <http://www.icertifi.com.tw>.

Linkou

Tel: 886-2-2601-1640

No.30-2, Ding Fwu Tsuen, Lin Kou
District, New Taipei City, Taiwan
(R.O.C.)

Kwei Shan

Tel: 886-3-271-8666

No.3-1, Lane 6, Wen San 3rd
St., Kwei Shan Dist., Tao Yuan
City 33381, Taiwan (R.O.C.)
No.2-1, Lane 6, Wen San 3rd
St., Kwei Shan Dist., Tao Yuan
City 33381, Taiwan (R.O.C.)

Kwei Shan Site II

Tel: 886-3-271-8640

No.14-1, Lane 19, Wen San 3rd
St., Kwei Shan Dist., Tao Yuan
City 333, Taiwan (R.O.C.)

If you have any suggestion, please feel free to contact us as below information.

Tel: 886-3-271-8666

Fax: 886-3-318-0345

Email: ICC_Service@icertifi.com.tw

==END==