

TEST REPORT

of

FCC Part 15 Subpart B & C

Product : **802.11b/g/n RTL8191SE miniCard**

Model(s): **RTL8191SE**

Applicant: **Acer Inc.**

Address: **8F, 88, Sec. 1, Hsin Tai Wu Rd.,
Hsichih, Taipei Hsien 221
Taiwan, R. O. C.**

Test Performed by:

International Standards Laboratory

<Lung-Tan LAB>

*Site Registration No.

BSMI: SL2-IN-E-0013; TAF: 0997; IC: IC4164-1 ;

VCCI: R-1435, C-1440, T-299, R-2598, C-2845; NEMKO: ELA 113B

*Address:

No. 120, Lane 180, San Ho Tsuen, Hsin Ho Rd.

Lung-Tan Hsiang, Tao Yuan County 325, Taiwan

*Tel : 886-3-407-1718; Fax: 886-3-407-1738

Report No.: **ISL-10LR016FC**

Issue Date : **2010/05/04**

Contents of Report

1.	General	1
1.1	Certification of Accuracy of Test Data	1
1.2	Test Results Summary	2
1.3	Test Frequencies of the WLAN of EUT.....	2
1.4	Test Conditions.....	3
2.	Description of Equipment Under Test (EUT)	4
3.	Description of Support Equipment.....	8
3.1	Description of Support Equipment	8
3.1.1	Software for Controlling Support Unit	8
4.	TEST RESULTS	9
4.1	Powerline Conducted Emissions [Section 15.207]	9
4.1.1	EUT Configuration	9
4.1.2	Test Procedure	9
4.1.3	EMI Receiver/Spectrum Analyzer Configuration (for the frequencies tested).....	9
4.1.4	802.11b Test Data:.....	10
4.1.5	802.11g Test Data:.....	12
4.1.6	802.11n(HT20) Test Data:.....	14
4.1.7	802.11n(HT40) Test Data:.....	16
4.2	DSSS Maximum Peak Output Power [Section 15.247 (b)(1)].....	18
4.2.1	Test Procedure The Transmitter output of EUT was connected to the spectrum analyzer.	18
4.2.2	Test Setup	18
4.2.3	802.11b Test Data.....	18
4.2.4	802.11g Test Data.....	21
4.2.5	802.11n(HT20) Test Data.....	23
4.2.6	802.11n(HT40) Test Data.....	25
4.3	Radiated Emission Measurement [Section [15.247(c)(4)]	27
4.3.1	EUT Configuration	27
4.3.2	Test Procedure	27
4.3.3	EMI Receiver/Spectrum Analyzer Configuration (for the frequencies tested).....	27
4.3.4	802.11b Test Data (30MHz – 1GHz):	28
4.3.5	802.11g Test Data.....	36
4.3.6	802.11n(HT20) Test Data (30MHz – 1GHz):	44
4.3.7	802.11n(HT40) Test Data.....	52
4.4	Band Edge Measurement.....	60
4.4.1	Test Procedure	60
4.4.2	Test Setup	60
4.4.3	802.11b Test Data:.....	61
4.4.4	802.11g Test Data:.....	63
4.4.5	802.11n(HT20) Test Data:.....	65
4.4.6	802.11n(HT40) Test Data:.....	67
4.5.1	Test Procedure (Radiated)	69
4.5.2	Test Setup (Radiated)	69
4.5.3	802.11b Test Data.....	70
4.5.4	802.11g Test Data.....	73
4.5.5	802.11n(HT20) Test Data.....	76
4.5.6	802.11n(HT40) Test Data.....	79
4.6	RF Exposure Measurement [Section 15.247(b)(4) & 1.1307(b)].....	82
5.	Appendix	83
5.1	Appendix A: Measurement Procedure for Power line Conducted Emissions.....	83
5.2	Appendix B: Test Procedure for Radiated Emissions	84
5.3	Appendix C: Test Equipment	85



5.3.1 Test Equipment List..... 85

5.3.2 Software for Controlling Spectrum/Receiver and Calculating Test Data..... 85

5.4 Appendix D: Layout of EUT and Support Equipment..... 86

5.4.1 General Conducted Test Configuration..... 86

5.4.2 General Radiation Test Configuration..... 87

5.5 Appendix E: Accuracy of Measurement 88

5.6 Appendix F: Photographs of EUT Configuration Test Set Up..... 89

5.7 Appendix G: Antenna Spec. 92

1. General

1.1 Certification of Accuracy of Test Data

Standards: CFR 47 Part 15 Subpart B Class B
CFR 47 Part 15 Subpart C (Section 15.247)

Test Procedure: ANSI C63.4:2003

Equipment Tested: 802.11b/g/n RTL8191SE miniCard

Model: RTL8191SE

Applied by: Acer Inc.

Sample received Date: 2010/04/20

Final test Date : 2010/05/03

Test Result PASS

Test Site: Chamber 14, Conduction 02

Temperature Refer to each site test data

Humidity: Refer to each site test data

Test Engineer:

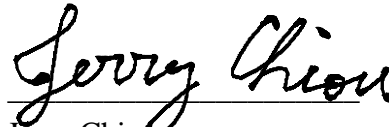
Jerry Chiou

All the tests in this report have been performed and recorded in accordance with the standards described above and performed by an independent electromagnetic compatibility consultant, International Standards Laboratory.

The test results contained in this report accurately represent the measurements of the characteristics and the energy generated by sample equipment under test at the time of the test. The sample equipment tested as described in this report is in compliance with the limits of above standards.

Approve & Signature

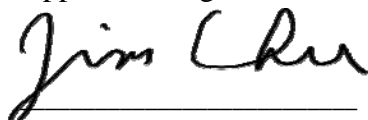

Jim Chu/ Director

Test results given in this report apply only to the specific sample(s) tested under stated test conditions. This report shall not be reproduced other than in full without the explicit written consent of ISL. This report totally contains 95 pages, including 1 cover page, 2 contents page, and 92 pages for the test description.

1.2 Test Results Summary

The 802.11b/g/n functions of EUT has been tested according to the FCC regulations listed below:

Tested Standards: 47 CFR Part 15 Subpart C			
Standard Section	Test Type	Result	Remarks
15.207	AC Power Line Emissions	Pass	
15.247(b)	Max. Peak Output Power	Pass	
15.247(c)	Radiated Emissions 30MHz – 25 GHz	Pass	
15.247 (c)	Band Edge Measurement	Pass	
15.247(b)(4)	Radiation Exposure	Pass	SAR report attached

1.3 Test Frequencies of the WLAN of EUT

Frequency of 802.11b, 802.11g and draft 802.11n Standard-20 MHz functions of EUT

EUT Channel	Test Frequency (MHz)
1	2412
6	2437
11	2462

Frequency of draft 802.11n Standard-40 MHz functions of EUT

EUT Channel	Test Frequency (MHz)
3	2422
6	2437
9	2452

1.4 Test Conditions

- a. Normal test conditions:
Temperature: 25 °C
Relative Humidity: 50% to 75%
- b. During the test, the EUT was set in continuously transmitting mode with a duty cycle of 100% (maximum allowed).
- c. The channel 1, 6, 11 of 802.11b , 802.11g and draft 802.11n Standard-20 MHz of EUT were all tested
- d. The channel 3, 6, 9 of draft 802.11n Standard-40 MHz of EUT were all tested
- e. 802.11g allows data rates 6Mbps to 54 Mbps. The EUT was tested in the data rate that produced the highest output power (6 Mbps). 802.11b allows data rates 1Mbps to 11 Mbps. The EUT was tested in the data rate that produced the highest output power (1 Mbps).
- f. draft 802.11n Standard-20 MHz allows data rates 6.5Mbps to 565Mbps. The EUT was tested in the data rate that produced the highest output power (MCS0 6.5 Mbps). draft 802.11n Standard-40 MHz allows data rates 13.5Mbps to 150 Mbps. The EUT was tested in the data rate that produced the highest output power (MCS0 13.5 Mbps).

2. Description of Equipment Under Test (EUT)

Description:	802.11b/g/n RTL8191SE miniCard
Condition:	Pre-Production
Model:	RTL8191SE
Frequency Range of 802.11b/g/n:	2400 - 2483.5 MHz
Support channel:	
802.11b/g	11 Channels
draft 802.11n-20MHz	11 Channels
draft 802.11n-40MHz	7 Channels
Modulation Skill:	
802.11b	DBPSK(1Mbps), DQPSK(2Mbps), CCK(5.5/11Mbps)
802.11g	OFDM (6M - 54Mbps)
Draft 802.11n	BPSK, QPSK, 16-QAM, 64-QAM
Antennas Type:	
Main antenna	PCB Antenna,made by WNC. Model: ZH9 WiFi Main Antenna
Aux antenna	PCB Antenna,made by WNC. Model: ZH9 WiFi Aux Antenna
Antenna Connected:	Connected to RF connector on the PCB of the 802.11b/g/n WLAN Adapter .The user is not possible to change the antenna without disassembling the personal computer.
Antenna peak Gain:	
Main antenna	2.39 dBi.
Aux antenna	-0.53 dBi
Power Type of wireless module:	3.3V DC from host
Output Power:	802.11b: 18.23dBm 802.11g: 16.61dBm 802.11n(HT20): 16.53dBm 802.11n(HT40): 16.57dBm

The channel and the operation frequency of 802.11b, 802.11g and draft 802.11n Standard-20 MHz is listed below:

Channel	Frequency(MHz)	Channel	Frequency(MHz)
01	2412	07	2442
02	2417	08	2447
03	2422	09	2452
04	2427	10	2457
05	2432	11	2462
06	2437		

The channels and the operation frequency of draft 802.11n Standard-40 MHz is listed below:

Channel	Frequency(MHz)	Channel	Frequency(MHz)
03	2422	07	2442
04	2427	08	2447
05	2432	09	2452
06	2437		

The EUT was installed in a Notebook Computer . There are several models and trade names for marketing demands and none of RF characteristics were changed among these models, and all models have built the same transmitted antenna (WLAN Antenna) and RF module in the same positions.

Product	Notebook Computer		
Trade Name	acer, Gateway, packard bell		
Model Name	AO521, LT22, dot s, ZH9, ZH9A, ZH9B		
Housing Type	Plastic		
AC Power Adapter	DELTA	Model	ADP-40 TH AA
	LEADER	Model	IU40-11190-011S
AC Power Adapter Rating	I/P: 100-240VAC O/P: 19Vdc, 2.15A		
AC Power Cord Type	2-pin without power cord		
DC Power Cable Type	Non-shielded DC (2.5m) with one ferrite core		
CPU	AMD	Model	K125 (1.7GHz)
			K325 (1.3GHz)
			K625 (1.5GHz)
			V105 (1.2GHz)
Memory Capacity	1GB/2GB		
10.1" LED Panel	AUO	Model	B101AW06 V0 B101AW06 V1
	LPL	Model	LP101WSB-TLN1 LP101WSB-TLP2
	SAMSUNG	Model	LTN101NT05-A01
	CMO	Model	N101L6-L0D
HDD	SEAGATE	Model	ST9160314AS (160GB)
			ST9250315AS (250GB)
			ST9320325AS (320GB)
	TOSHIBA	Model	MK1665GSX (160GB)
			MK2565GSX (250GB)
			MK3265GSX (320GB)
HGST	Model	HTS545016B9A300 (160GB)	
		HTS545025B9A300 (250GB)	
		HTS545032B9A300 (320GB)	
	WD	Model	WD1600BEVT-22A23T0 (160GB)
			WD2500BEVT-22A23T0 (250GB)
			WD3200BEVT-22A23T0 (320GB)
Camera	Suyin	Model	SY9665SN
	Chicony	Model	CH9665SN
	Liteon	Model	LT9665AL

3G Card (Optional)	Huawei	Model	EM770W
	Ericsson	Model	F3307
	QUALCOMM	Model	Gobi2000
Bluetooth (Optional)	Broadcom (Foxconn)	Model	BCM92046 (T60H928.33)
	Broadcom (Foxconn)	Model	BCM92070 (T77H114.01)
	Atheros (Foxconn)	Model	AR3011 (T77H056.00)
Modem (Optional)	Agere	Model	A40
Battery	SIMPLO	Model	UM09E70

The I/O ports of EUT are listed below:

I/O Port Types	Quantity
DC In port	1
MIC In port	1
Headphone/SPDIF port	1
LAN port	1
USB port	3
VGA port	1
Card reader	1
HDMI port	1

The final test configuration:

AC Power Adapter	DELTA (Model: ADP-40 TH AA)
CPU	AMD Athlon (tm) II Neo K325 Dual-Core Processor 1.30GHz
LED Panel	LPL (Model: LP101WSB-TLN1)
HDD	Seagate (Model: ST9250315AS) 250GB
Battery	SIMPLO (Model: UM09E70)

3. Description of Support Equipment

3.1 Description of Support Equipment

None

3.1.1 Software for Controlling Support Unit

Test programs exercising various part of EUT were used. The programs were executed as follows:

- A. Read and write to the disk drives.
- B. The RF software makes the transmitter continuously sending RF signals
- C. Repeat the above steps.

	Filename	Issued Date
Realtek v0.27.525.2009	MP819xVC.exe	05/25/2009

4. TEST RESULTS

4.1 Powerline Conducted Emissions [Section 15.207]

4.1.1 EUT Configuration

The EUT was set up on the non-conductive table that is 1.0 by 1.5 meter, 80cm above ground. The wall of the shielded room was located 40cm to the rear of the EUT.

Power to the EUT was provided through the LISN. The impedance vs. frequency characteristic of the LISN is complied with the limit used.

Both lines (neutral and hot) were connected to the LISN in series at testing. A coaxial-type connector which provides one 50 ohms terminating impedance was provided for connecting the test instrument. The excess length of the power cord was folded back and forth at the center of the lead so as to form a bundle not exceeding 40cm in length.

Any changes made to the configuration, or modifications made to the EUT, during testing are noted in the following test record.

If the EUT is a Personal Computer or a peripheral of personal computer, and the personal computer has an auxiliary AC outlet which can be used for providing power to an external monitor, then all measurements will be made with the monitor power from first the computer-mounted AC outlet and then a floor-mounted AC outlet.

4.1.2 Test Procedure

The system was set up as described above, with the EMI diagnostic software running. The main power line conducted EMI tests were run on the hot and neutral conductors of the power cord and the results were recorded. The effect of varying the position of the interface cables has been investigated to find the configuration that produces maximum emission.

At the frequencies where the peak values of the emissions were higher than 6dB below the applicable limits, the emissions were also measured with the quasi-peak detectors. At the frequencies where the quasi-peak values of the emissions were higher than 6dB below the applicable average limits, the emissions were also measured with the average detectors.

The highest emissions were analyzed in details by operating the spectrum analyzer in fixed tuned mode to determine the nature of the emissions and to provide information which could be useful in reducing their amplitude.

4.1.3 EMI Receiver/Spectrum Analyzer Configuration (for the frequencies tested)

Frequency Range	150 KHz--30MHz
Detector Function	Quasi-Peak/Average
Bandwidth (RBW)	9KHz

4.1.4 802.11b Test Data:

Power Line Conducted Emissions (Hot) Lowest, Middle, Highest channel

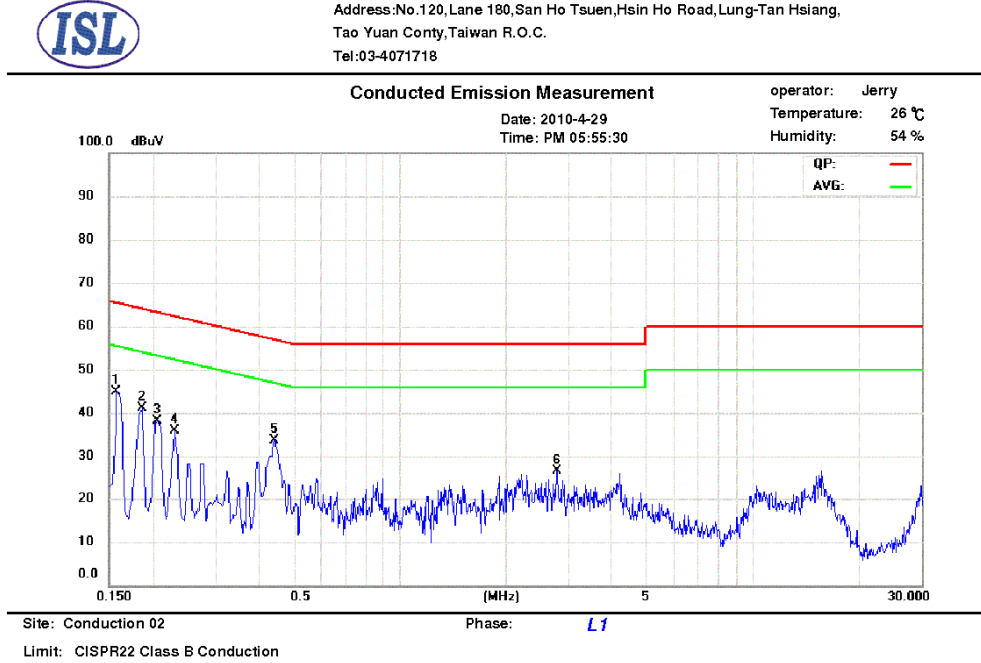

No.	Frequency MHz	LISN Loss dB	Cable Loss dB	QP Correct. dBuV	QP Limit dBuV	QP Margin dB	AVG Correct. dBuV	AVG Limit dBuV	AVG Margin dB	Note
1	0.1580	0.14	0.02	44.70	65.5	-20.8	27.48	55.5	-28.0	
2	0.1860	0.14	0.02	39.75	64.2	-24.4	23.87	54.2	-30.3	
3	0.2060	0.14	0.02	33.98	63.3	-29.3	17.26	53.3	-36.1	
4	0.2300	0.14	0.03	36.01	62.4	-26.4	17.82	52.4	-34.6	
5	0.4420	0.15	0.04	31.24	57.0	-25.7	23.64	47.0	-23.3	
6	2.7860	0.23	0.1	21.47	56.0	-34.5	15.84	46.0	-30.1	

Power Line Conducted Emissions (Neutral) Lowest, Middle, Highest channel



Address: No.120, Lane 180, San Ho Tsuen, Hsin Ho Road, Lung-Tan Hsiang,
Tao Yuan Conty, Taiwan R.O.C.
Tel: 03-4071718

Conducted Emission Measurement

operator: Jerry
Temperature: 26 °C
Humidity: 54 %

Date: 2010-4-29
Time: PM 05:57:49

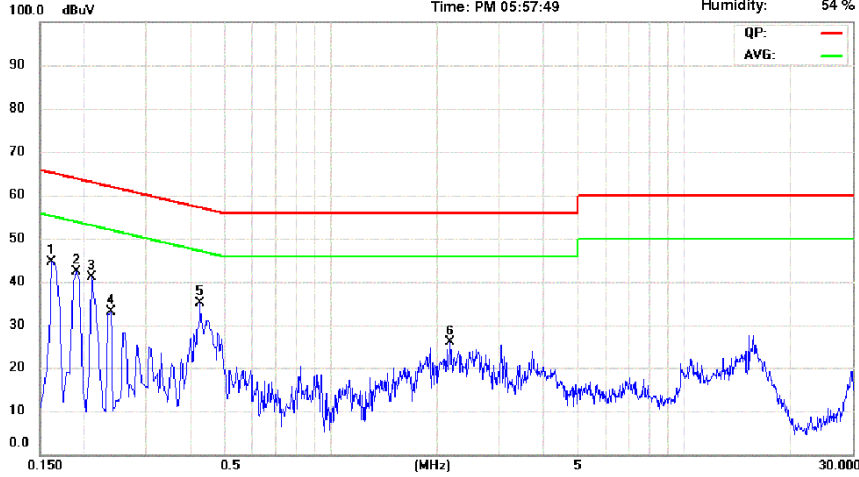

Site: Conduction 02

Phase: *N*

Limit: CISPR22 Class B Conduction

No.	Frequency MHz	LISN Loss dB	Cable Loss dB	QP Correct. dBuV	QP Limit dBuV	QP Margin dB	AVG Correct. dBuV	AVG Limit dBuV	AVG Margin dB	Note
1	0.1620	0.24	0.02	44.14	65.3	-21.2	26.41	55.3	-28.9	
2	0.1900	0.24	0.02	38.17	64.0	-25.8	20.74	54.0	-33.3	
3	0.2100	0.24	0.02	37.11	63.2	-26.1	20.63	53.2	-32.5	
4	0.2380	0.24	0.03	32.14	62.1	-30.0	14.15	52.1	-38.0	
5	0.4260	0.25	0.04	29.94	57.3	-27.3	24.58	47.3	-22.7	
6	2.1820	0.31	0.08	18.01	56.0	-37.9	11.27	46.0	-34.7	

* NOTE: During the test, the EMI receiver was set to Max. Hold then switch the EUT Channel between Lowest, Middle, Highest to get the maximum reading of all these channels.
Margin = Amplitude + Insertion Loss- Limit
A margin of -8dB means that the emission is 8dB below the limit

4.1.5 802.11g Test Data:

Power Line Conducted Emissions (Hot) Lowest, Middle, Highest channel

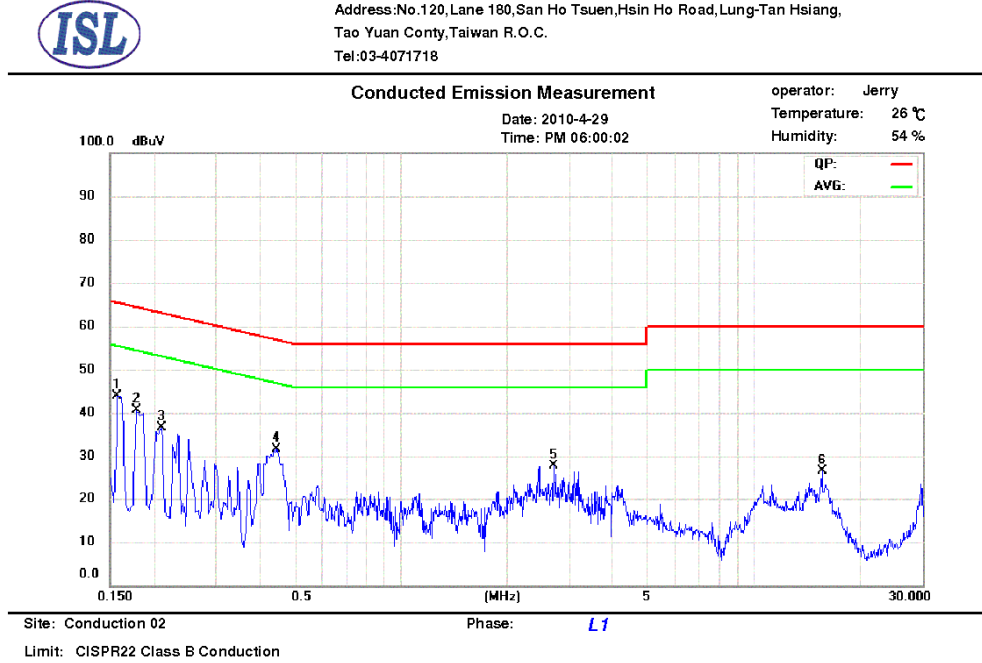

Power Line Conducted Emissions (Neutral) Lowest, Middle, Highest channel



Address: No.120, Lane 180, San Ho Tsuen, Hsin Ho Road, Lung-Tan Hsiang,
Tao Yuan Conty, Taiwan R.O.C.
Tel: 03-4071718

Conducted Emission Measurement

operator: Jerry
Temperature: 26 °C
Humidity: 54 %

Date: 2010-4-29
Time: PM 06:01:57

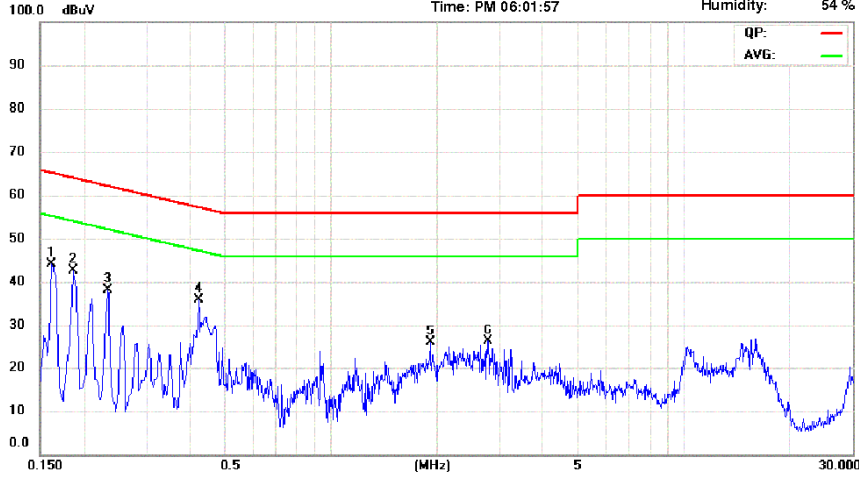

Site: Conduction 02

Phase: N

Limit: CISPR22 Class B Conduction

No.	Frequency MHz	LISN Loss dB	Cable Loss dB	QP Correct. dBuV	QP Limit dBuV	QP Margin dB	AVG Correct. dBuV	AVG Limit dBuV	AVG Margin dB	Note
1	0.1620	0.24	0.02	43.10	65.3	-22.2	26.13	55.3	-29.2	
2	0.1860	0.24	0.02	38.89	64.2	-25.3	23.28	54.2	-30.9	
3	0.2340	0.24	0.03	30.87	62.3	-31.4	16.82	52.3	-35.4	
4	0.4220	0.25	0.04	30.19	57.4	-27.2	25.71	47.4	-21.7	
5	1.9180	0.31	0.08	19.84	56.0	-36.1	15.75	46.0	-30.2	
6	2.7860	0.33	0.1	19.37	56.0	-36.6	12.94	46.0	-33.0	

* NOTE: During the test, the EMI receiver was set to Max. Hold then switch the EUT Channel between Lowest, Middle, Highest to get the maximum reading of all these channels.
Margin = Amplitude + Insertion Loss- Limit
A margin of -8dB means that the emission is 8dB below the limit

4.1.6 802.11n(HT20) Test Data:

Power Line Conducted Emissions (Hot) Lowest, Middle, Highest channel

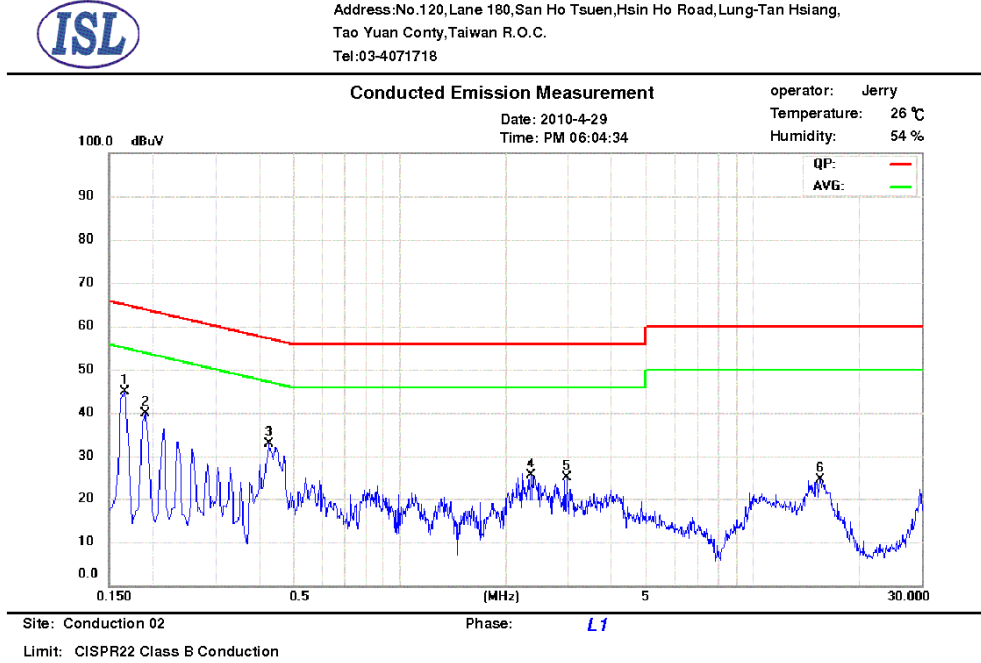

No.	Frequency MHz	LISN Loss dB	Cable Loss dB	QP Correct. dBuV	QP Limit dBuV	QP Margin dB	AVG Correct. dBuV	AVG Limit dBuV	AVG Margin dB	Note
1	0.1660	0.14	0.02	41.48	65.1	-23.6	25.09	55.1	-30.0	
2	0.1900	0.14	0.02	37.18	64.0	-26.8	21.28	54.0	-32.7	
3	0.4260	0.15	0.04	31.28	57.3	-26.0	26.53	47.3	-20.8	
4	2.3500	0.22	0.09	19.04	56.0	-36.9	13.05	46.0	-32.9	
5	2.9620	0.24	0.1	18.34	56.0	-37.6	11.03	46.0	-34.9	
6	15.5140	0.65	0.2	17.97	60.0	-42.0	11.06	50.0	-38.9	

Power Line Conducted Emissions (Neutral) Lowest, Middle, Highest channel



Address: No.120, Lane 180, San Ho Tsuen, Hsin Ho Road, Lung-Tan Hsiang,
Tao Yuan Conty, Taiwan R.O.C.
Tel: 03-4071718

Conducted Emission Measurement

operator: Jerry
Temperature: 26 °C
Humidity: 54 %

Date: 2010-4-29
Time: PM 06:06:19

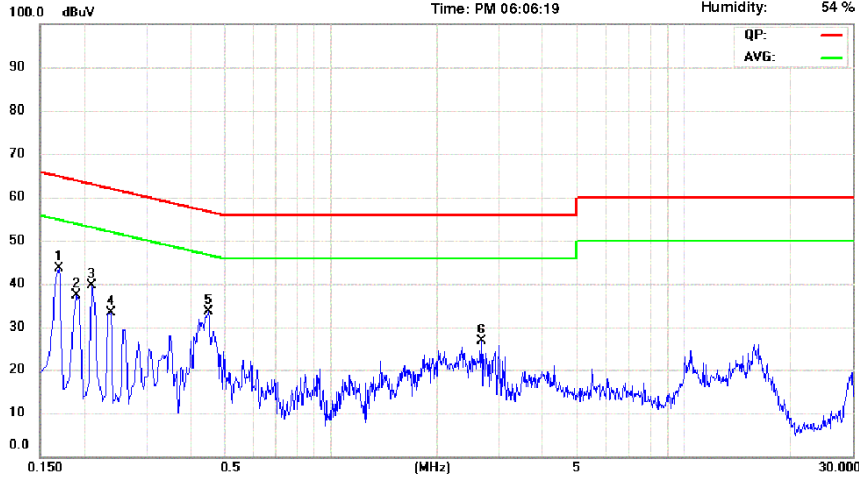

Site: Conduction 02

Phase: N

Limit: CISPR22 Class B Conduction

No.	Frequency MHz	LISN Loss dB	Cable Loss dB	QP Correct. dBuV	QP Limit dBuV	QP Margin dB	AVG Correct. dBuV	AVG Limit dBuV	AVG Margin dB	Note
1	0.1700	0.24	0.02	38.68	64.9	-26.2	20.12	54.9	-34.8	
2	0.1900	0.24	0.02	36.68	64.0	-27.3	21.36	54.0	-32.6	
3	0.2100	0.24	0.02	30.81	63.2	-32.4	15.32	53.2	-37.8	
4	0.2380	0.24	0.03	29.78	62.1	-32.3	13.96	52.1	-38.2	
5	0.4500	0.25	0.04	30.40	56.8	-26.4	26.14	46.8	-20.7	
6	2.6740	0.33	0.09	17.04	56.0	-38.9	9.95	46.0	-36.0	

* NOTE: During the test, the EMI receiver was set to Max. Hold then switch the EUT Channel between Lowest, Middle, Highest to get the maximum reading of all these channels.
Margin = Amplitude + Insertion Loss- Limit
A margin of -8dB means that the emission is 8dB below the limit

4.1.7 802.11n(HT40) Test Data:

Power Line Conducted Emissions (Hot) Lowest, Middle, Highest channel

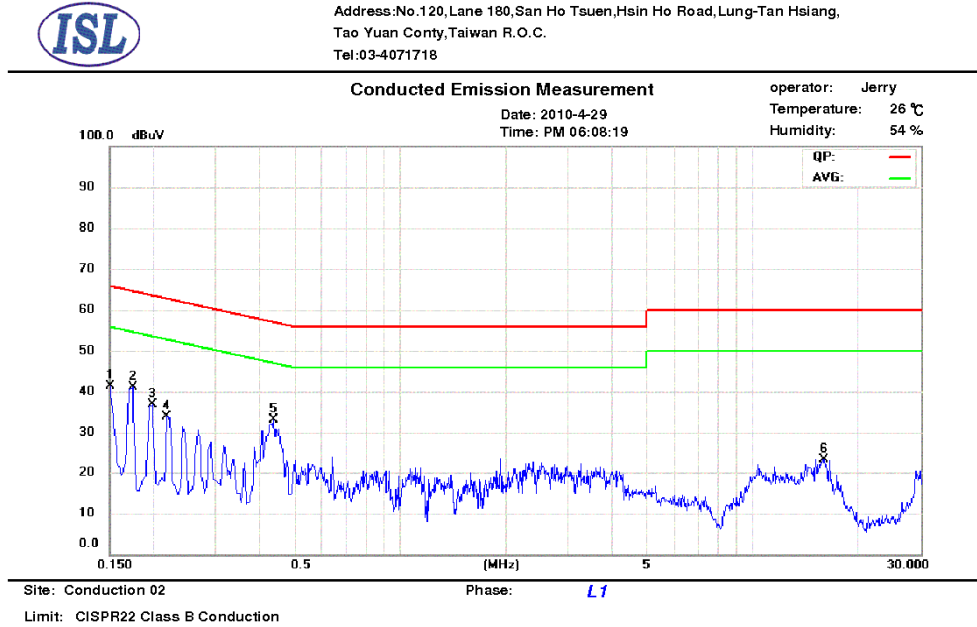

No.	Frequency MHz	LISN Loss dB	Cable Loss dB	QP Correct dBuV	QP Limit dBuV	QP Margin dB	AVG Correct dBuV	AVG Limit dBuV	AVG Margin dB	Note
1	0.1500	0.14	0.02	42.64	66.0	-23.3	22.89	56.0	-33.1	
2	0.1740	0.14	0.02	37.56	64.7	-27.2	17.61	54.7	-37.1	
3	0.1980	0.14	0.02	33.27	63.6	-30.4	16.25	53.6	-37.4	
4	0.2180	0.14	0.02	32.61	62.8	-30.2	18.13	52.8	-34.7	
5	0.4380	0.15	0.04	30.19	57.1	-26.9	22.53	47.1	-24.5	
6	16.0340	0.69	0.2	18.93	60.0	-41.0	11.97	50.0	-38.0	

Power Line Conducted Emissions (Neutral) Lowest, Middle, Highest channel



Address: No.120, Lane 180, San Ho Tsuen, Hsin Ho Road, Lung-Tan Hsiang,
Tao Yuan Conty, Taiwan R.O.C.
Tel: 03-4071718

Conducted Emission Measurement

operator: Jerry
Temperature: 26 °C
Humidity: 54 %

Date: 2010-4-29
Time: PM 06:10:10

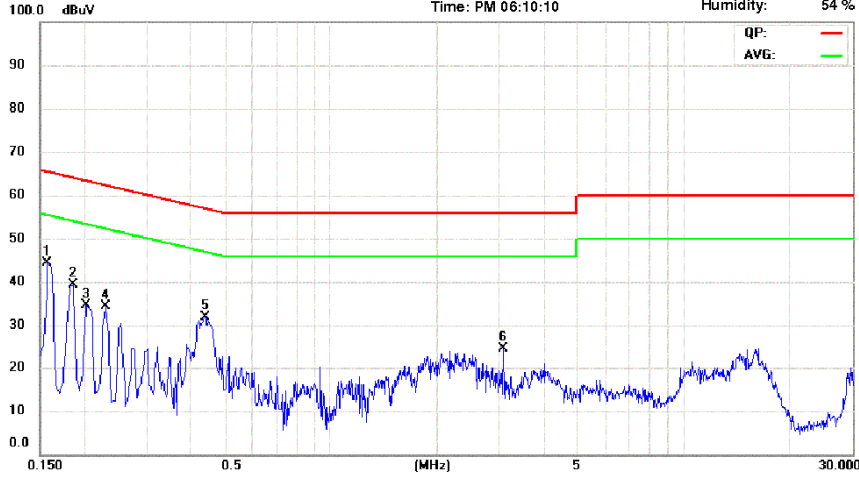

Site: Conduction 02

Phase: N

Limit: CISPR22 Class B Conduction

No.	Frequency MHz	LISN Loss dB	Cable Loss dB	QP Correct. dBuV	QP Limit dBuV	QP Margin dB	AVG Correct. dBuV	AVG Limit dBuV	AVG Margin dB	Note
1	0.1580	0.24	0.02	42.93	65.5	-22.6	26.26	55.5	-29.3	
2	0.1860	0.24	0.02	38.05	64.2	-26.1	22.25	54.2	-31.9	
3	0.2030	0.24	0.02	32.00	63.4	-31.4	13.55	53.4	-39.9	
4	0.2300	0.24	0.03	27.35	62.4	-35.1	10.56	52.4	-41.8	
5	0.4420	0.25	0.04	28.22	57.0	-28.8	22.16	47.0	-24.8	
6	3.0740	0.34	0.1	14.05	56.0	-41.9	6.88	46.0	-39.1	

* NOTE: During the test, the EMI receiver was set to Max. Hold then switch the EUT Channel between Lowest, Middle, Highest to get the maximum reading of all these channels.
Margin = Amplitude + Insertion Loss- Limit
A margin of -8dB means that the emission is 8dB below the limit

4.2 DSSS Maximum Peak Output Power [Section 15.247 (b)(1)]

4.2.1 Test Procedure

The Transmitter output of EUT was connected to the spectrum analyzer.

The test is performed in accordance with FCC document KDB558074 “Measurement of Digital Transmission Systems Operating under Section 15.247”, March 23, 2005. The transmitter operates continuously therefore Power Output Option 2, Method # 1 is used.

Equipment mode	Spectrum analyzer
Detector function	Channel Power
Channel BW	25MHz / 45MHz
RBW	1MHz
VBW	3MHz
Center frequency	fundamental frequency tested
Sweep time	auto

4.2.2 Test Setup



4.2.3 802.11b Test Data

802.11b Maximum Peak Output Power

Temp. (° C): 25

Test Engr: Jerry

Humidity (%): 55

Channel	Frequency (MHz)	Analyzer Reading (dBm)	Cable Loss (dB)	Peak Power Output (mW)	Peak Power Output (dBm)	Limit (dBm)	Pass/Fail
1	2412	17.13	1.1	66.53	18.23	30	Pass
6	2437	16.68	1.1	59.98	17.78	30	Pass
11	2462	16.62	1.1	59.16	17.72	30	Pass

802.11b Lowest Channel:

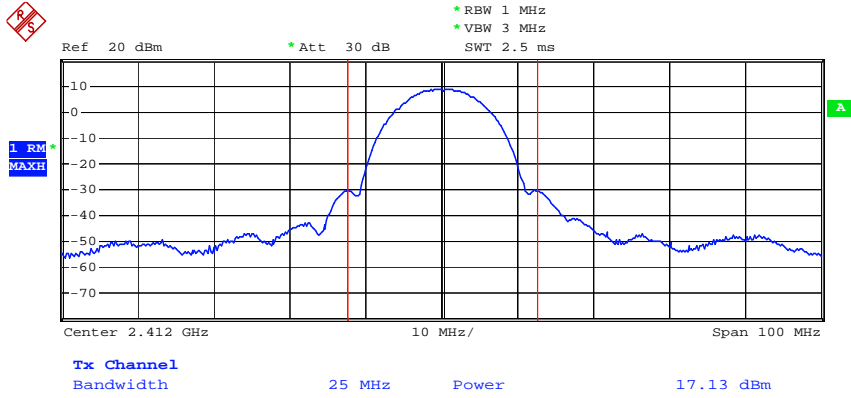

Date: 26.APR.2010 11:22:17

802.11b Middle Channel:

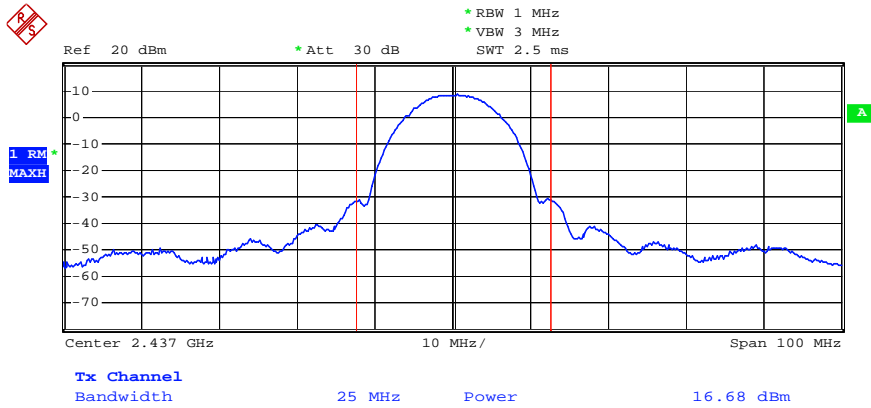

Date: 26.APR.2010 11:43:57

802.11b Highest Channel:

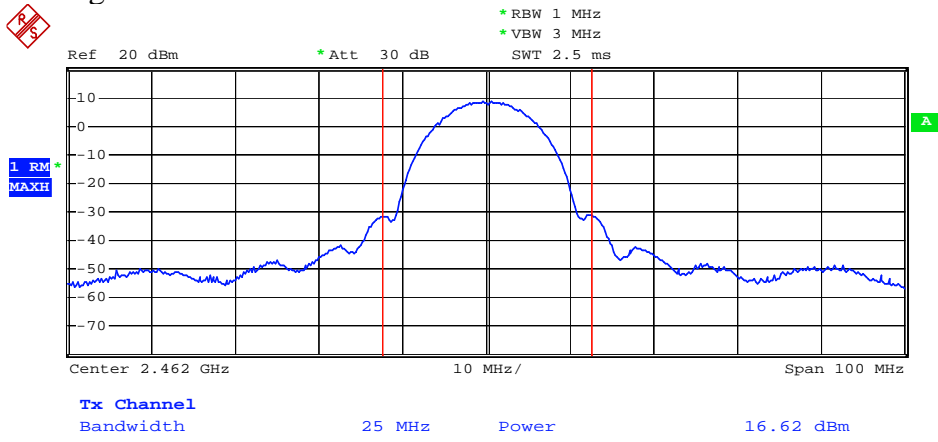

Date: 26.APR.2010 11:48:30

4.2.4 802.11g Test Data

802.11g Maximum Peak Output Power

Temp. (° C): 25

Test Engr: Jerry

Humidity (%): 55

Channel	Frequency (MHz)	Analyzer Reading (dBm)	Cable Loss (dB)	Peak Power Output (mW)	Peak Power Output (dBm)	Limit (dBm)	Pass/Fail
1	2412	15.51	1.1	45.81	16.61	30	Pass
6	2437	15.43	1.1	44.98	16.53	30	Pass
11	2462	14.06	1.1	32.81	15.16	30	Pass

802.11g Lowest Channel:

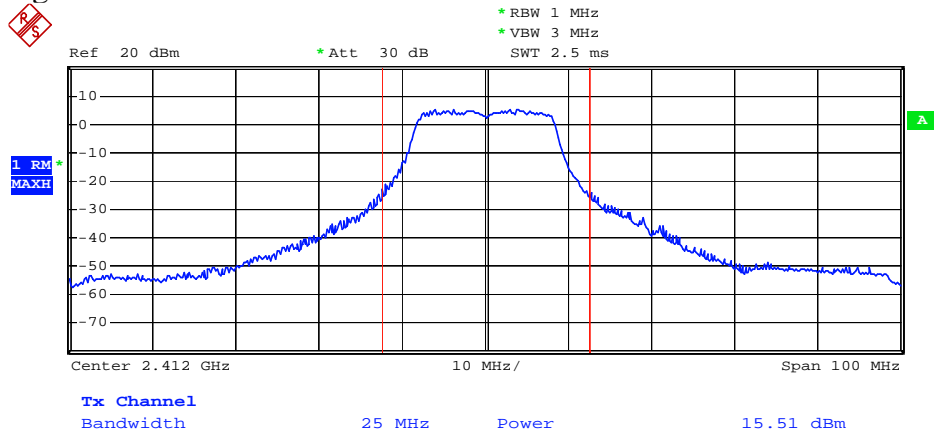

Date: 26.APR.2010 12:34:25

802.11g Middle Channel:

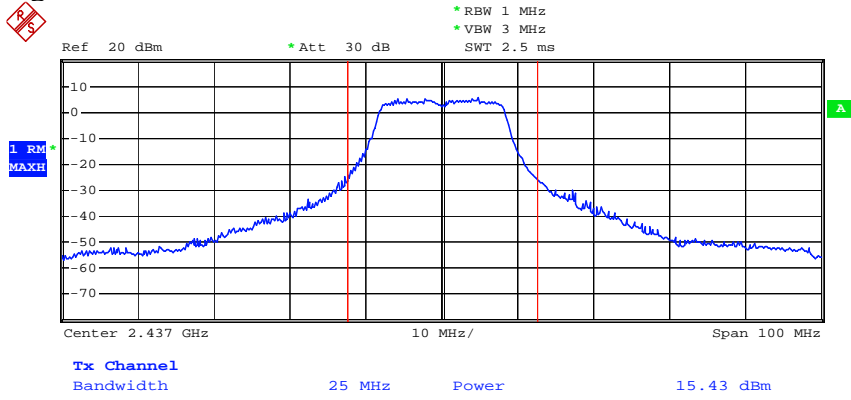

Date: 26.APR.2010 12:26:14

802.11g Highest Channel:

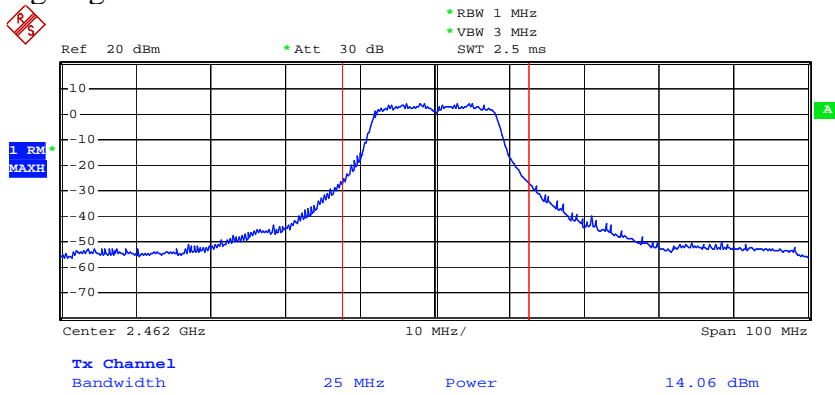

Date: 26.APR.2010 12:32:35

4.2.5 802.11n(HT20) Test Data

802.11n(HT20) Maximum Peak Output Power

Temp. (° C): 25

Test Engr: Jerry

Humidity (%): 55

Channel	Frequency (MHz)	Analyzer Reading (dBm)	Cable Loss (dB)	Peak Power Output (mW)	Peak Power Output (dBm)	Limit (dBm)	Pass/Fail
1	2412	15.36	1.1	44.26	16.46	30	Pass
6	2437	15.43	1.1	44.98	16.53	30	Pass
11	2462	14.02	1.1	32.51	15.12	30	Pass

802.11n (HT20) Lowest Channel:

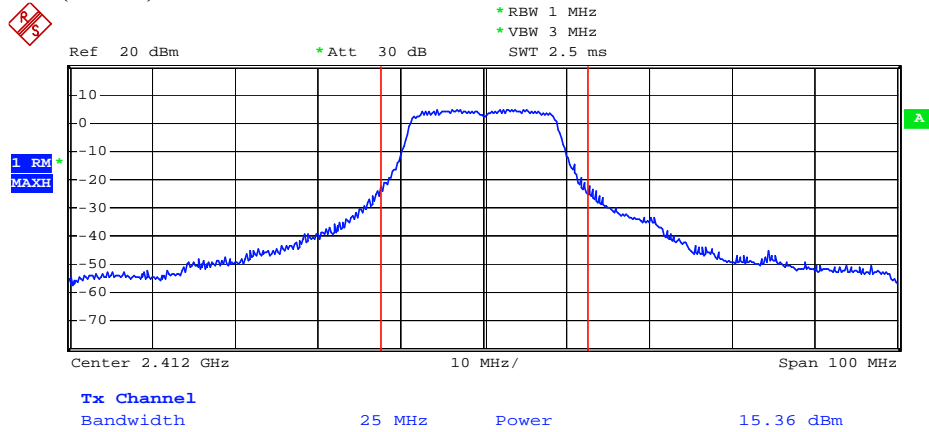

Date: 26.APR.2010 14:22:14

802.11n (HT20) Middle Channel:

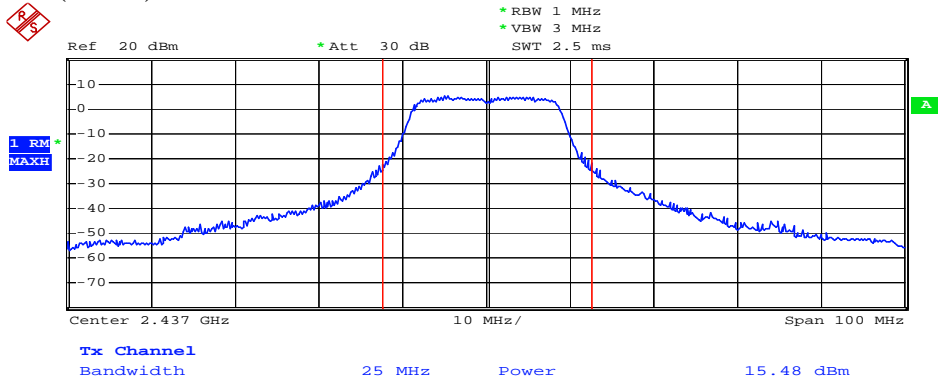

Date: 26.APR.2010 14:23:29

802.11n (HT20) Highest Channel:

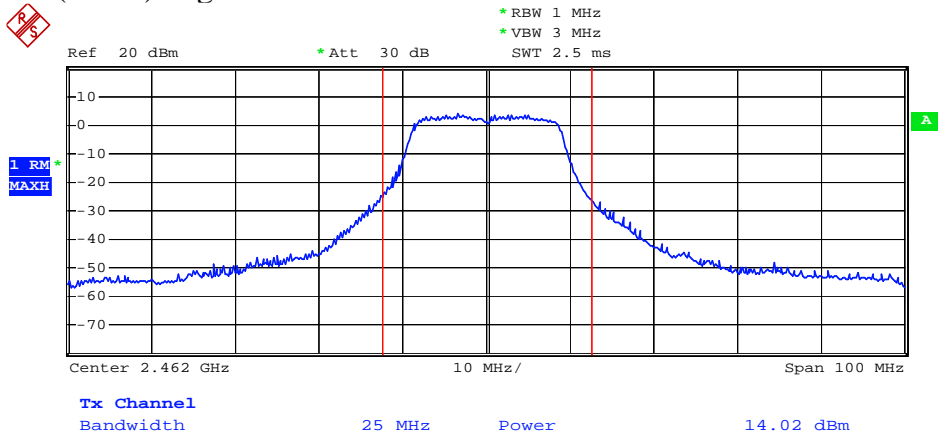

Date: 26.APR.2010 14:24:42

4.2.6 802.11n(HT40) Test Data

802.11n(HT40) Maximum Peak Output Power

Temp. (° C): 25

Test Engr: Jerry

Humidity (%): 55

Channel	Frequency (MHz)	Analyzer Reading (dBm)	Cable Loss (dB)	Peak Power Output (mW)	Peak Power Output (dBm)	Limit (dBm)	Pass/Fail
3	2422	15.47	1.1	45.39	16.57	30	Pass
6	2437	15.41	1.1	44.77	16.51	30	Pass
9	2452	13.49	1.1	28.77	14.59	30	Pass

802.11n (HT40) Lowest Channel:

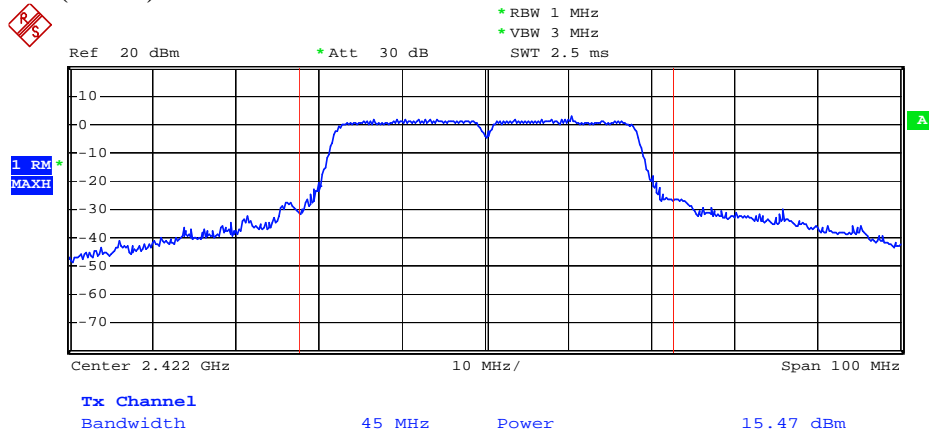

Date: 26.APR.2010 14:30:42

802.11n (HT40) Middle Channel:

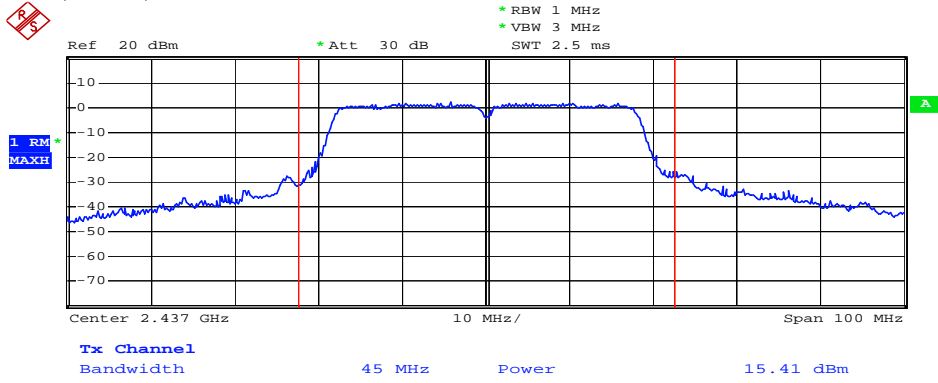

Date: 26.APR.2010 14:33:32

802.11n (HT40) Highest Channel:

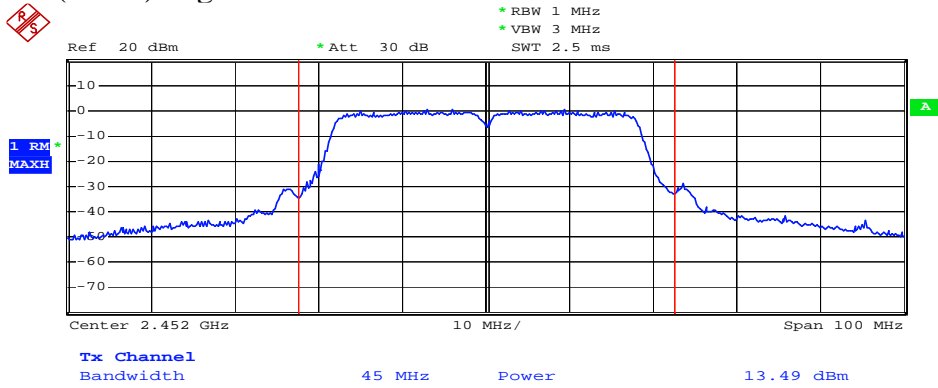

Date: 26.APR.2010 14:36:05

4.3 Radiated Emission Measurement [Section [15.247(c)(4)]

4.3.1 EUT Configuration

The equipment under test was set up on the 10 meter chamber with measurement distance of 3 meters. The EUT was placed on a non-conductive table 80cm above ground.

Any changes made to the configuration, or modifications made to the EUT, during testing are noted in the following test record.

4.3.2 Test Procedure

The system was set up as described above, with the EMI diagnostic software running. We found the maximum readings by varying the height of antenna and then rotating the turntable. Both polarization of antenna, horizontal and vertical, are measured.

30M to 1GHz: The highest emissions between 30 MHz to 1000 MHz were also analyzed in details by operating the spectrum analyzer and/or EMI receiver in quasi-peak mode to determine the precise amplitude of the emissions. While doing so, the interconnecting cables and major parts of the system were moved around, the antenna height was varied between one and four meters, its polarization was varied between vertical and horizontal, and the turntable was slowly rotated, to maximize the emission.

1GHz – 25GHz: The highest emissions were also analyzed in details by operating the spectrum analyzer and/or EMI receiver in peak mode to determine the precise amplitude of the emission. While doing so, the interconnecting cables and major parts of the system were moved around, the antenna height was varied between one and four meters, its polarization was varied between vertical and horizontal, and the turntable was slowly rotated, to maximize the emission. During test the EMI receiver and spectrum was setup according to *EMI Receiver/Spectrum Analyzer Configuration*.

For the test of 2nd to 10th harmonics frequencies, the equipment setup was also refer to EMI Receiver/Spectrum Analyzer Configuration. The frequencies were tested using Peak mode first, if the test data is higher than the emissions limit, an additional measurement using Average mode will be performed and the average reading will be compared to the limit and record in test report.

4.3.3 EMI Receiver/Spectrum Analyzer Configuration (for the frequencies tested)

Frequency Range Tested:	30MHz~1000MHz
Detector Function:	Quasi-Peak Mode
Resolution Bandwidth (RBW):	120KHz
Video Bandwidth (VBW)	360KHz
Frequency Range Tested:	1GHz – 25 GHz
Detector Function:	Peak Mode
Resolution Bandwidth (RBW):	1MHz
Video Bandwidth (VBW)	3MHz
Frequency Range Tested:	1GHz – 25 GHz
Detector Function:	Average Mode
Resolution Bandwidth (RBW):	1MHz
Video Bandwidth (VBW)	10 Hz

4.3.4 802.11b Test Data (30MHz – 1GHz):

30M – 1GHz Open Field Radiated Emissions (Horizontal) Lowest, Middle, Highest channel

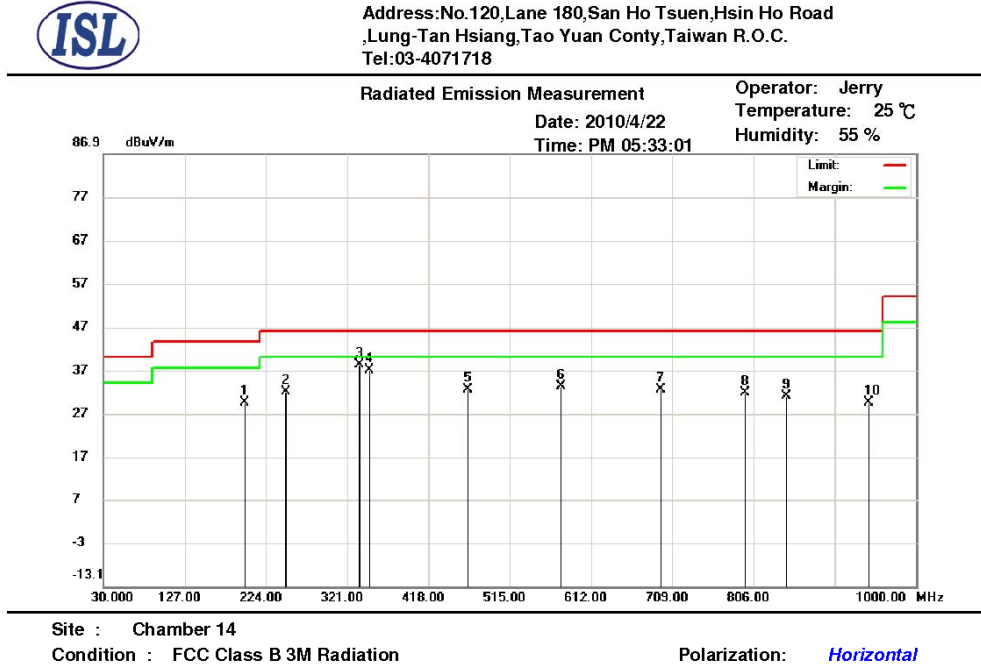

Mk.	Frequency (MHz)	RX_R (dBuV/m)	Ant_F (dB)	Cab_L (dB)	PreAmp (dB)	Emission (dBuV/m)	Limit (dBuV/m)	Margin (dB)	Ant.Pos (cm)	Tab.Pos (deg.)	Detector
1	198.7800	49.55	10.21	0.9	31.02	29.64	43.50	-13.86	264	133	peak
2	248.2500	49.29	12.66	1	30.88	32.07	46.00	-13.93	283	7	peak
3	335.5500	53.05	14.8	1.07	30.71	38.21	46.00	-7.79	256	179	peak
4	347.1900	51.50	15.12	1.09	30.71	37.00	46.00	-9.00	154	276	peak
5	464.5600	44.51	17.27	1.3	30.6	32.48	46.00	-13.52	358	297	peak
6	576.1100	43.53	18.86	1.45	30.56	33.28	46.00	-12.72	288	351	peak
7	695.4200	41.92	19.57	1.59	30.5	32.58	46.00	-13.42	243	184	peak
8	796.3000	40.03	20.56	1.69	30.54	31.74	46.00	-14.26	357	5	peak
9	845.7700	38.47	21.15	1.79	30.48	30.93	46.00	-15.07	100	344	peak
10	943.7400	36.10	21.94	1.89	30.37	29.56	46.00	-16.44	262	0	peak

*:Maximum data x:Over limit !:over margin

30M – 1GHz Open Field Radiated Emissions (Vertical) Lowest, Middle, Highest channel

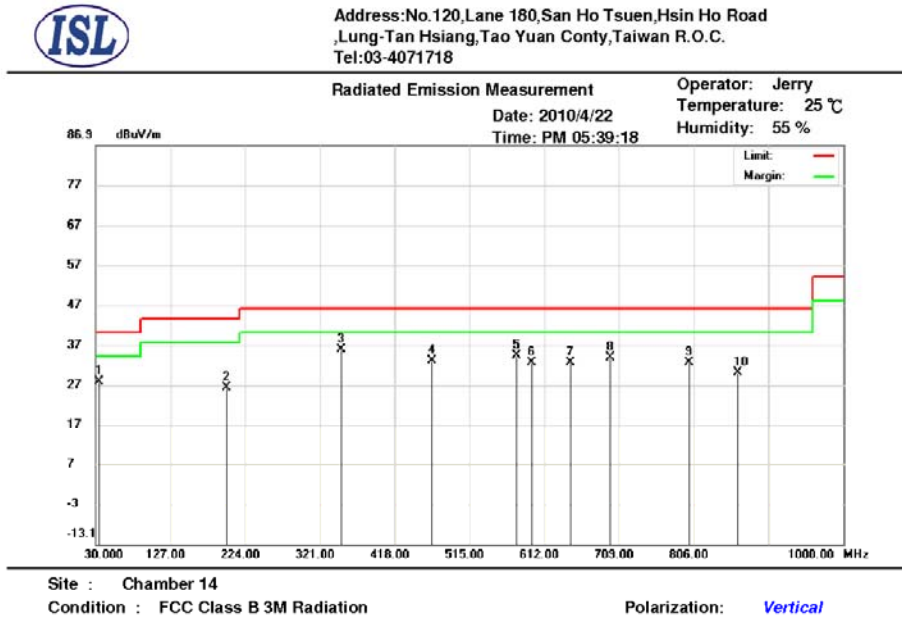

Mk.	Frequency (MHz)	RX_R (dBuV/m)	Ant_LF (dB)	Cab_L (dB)	PreAmp (dB)	Emission (dBuV/m)	Limit (dBuV/m)	Margin (dB)	Ant.Pos (cm)	Tab.Pos (deg.)	Detector
1	34.8500	41.72	16.79	0.4	31.11	27.80	40.00	-12.20	100	140	peak
2	199.7500	46.16	10.28	0.9	31.02	26.32	43.50	-17.18	199	77	peak
3	348.1600	50.29	15.15	1.1	30.71	35.83	46.00	-10.17	100	205	peak
4	466.5000	45.07	17.3	1.3	30.59	33.08	46.00	-12.92	170	94	peak
5	576.1100	44.49	18.86	1.45	30.56	34.24	46.00	-11.76	370	160	peak
6	595.5100	42.67	18.97	1.49	30.56	32.57	46.00	-13.43	120	307	peak
7	645.9500	42.20	19.28	1.5	30.53	32.45	46.00	-13.55	100	349	peak
8	697.3600	43.10	19.58	1.59	30.5	33.77	46.00	-12.23	106	175	peak
9	800.1800	40.71	20.6	1.7	30.54	32.47	46.00	-13.53	327	36	peak
10	863.2300	37.49	21.28	1.8	30.46	30.11	46.00	-15.89	100	251	peak

*:Maximum data x:Over limit !:over margin

NOTE:

- During the Pre-test, the EUT has been tested for Lowest, Middle, Highest channel transmit from Main and Aux antenna respectively to get all the critical emission frequencies. In the final test all the critical emission frequencies has been tested and the test data are listed above.
- Margin = Corrected Amplitude – Limit
Corrected Amplitude = Radiated Amplitude + Antenna Correction Factor + Cable Loss - Pre-Amplifier Gain
A margin of -8dB means that the emission is 8dB below the limit

All frequencies from 30MHz to 1GHz have been tested

1GHz~ 25 GHz (Horizontal), Lowest Channel



Address: No.120, Lane 180, San Ho Tsuen, Hsin Ho Road
.Lung-Tan Hsiang, Tao Yuan Conty, Taiwan R.O.C.
Tel: 03-4071718

Radiated Emission Measurement

Date: 2010/4/26
Time: PM 01:10:25

Operator: Jerry
Temperature: 25 °C
Humidity: 55 %

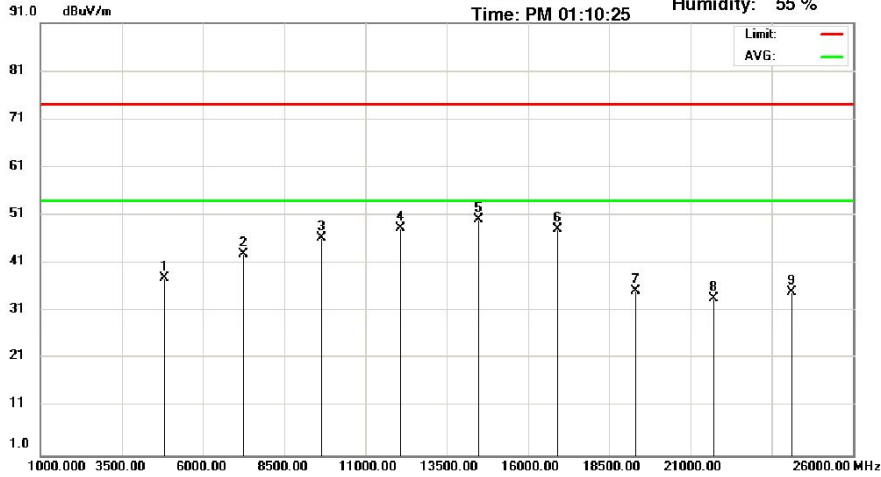

Site : Chamber 14

Condition : FCC Class B Radiation(Peak)

Polarization: *Horizontal*

Mk.	Frequency (MHz)	RX_R (dBuV/m)	Ant_F (dB)	Cab_L (dB)	PreAmp (dB)	Emission (dBuV/m)	Limit (dBuV/m)	Margin (dB)	Ant.Pos (cm)	Tab.Pos (deg.)	Detector
1	4824.000	37.03	33.34	2.83	35.24	37.96	74.00	-36.04	352	107	peak
2	7236.000	37.20	37.78	3.39	35.45	42.92	74.00	-31.08	152	77	peak
3	9646.000	38.38	39.77	3.93	35.77	46.31	74.00	-27.69	226	153	peak
4	12060.000	37.63	41.44	4.41	35.03	48.45	74.00	-25.55	105	140	peak
5	14472.000	35.89	43.69	4.71	34.06	50.23	74.00	-23.77	100	84	peak
6	16884.000	35.04	41.87	5.28	33.96	48.23	74.00	-25.77	100	66	peak
7	19296.000	31.86	32.02	5.7	34.31	35.27	74.00	-38.73	289	106	peak
8	21708.000	29.89	32.48	6.04	34.72	33.69	74.00	-40.31	247	11	peak
9	24120.000	30.63	33.15	6.42	35.22	34.98	74.00	-39.02	100	333	peak

*:Maximum data x:Over limit !:over margin

1GHz~ 25 GHz (Vertical), Lowest Channel

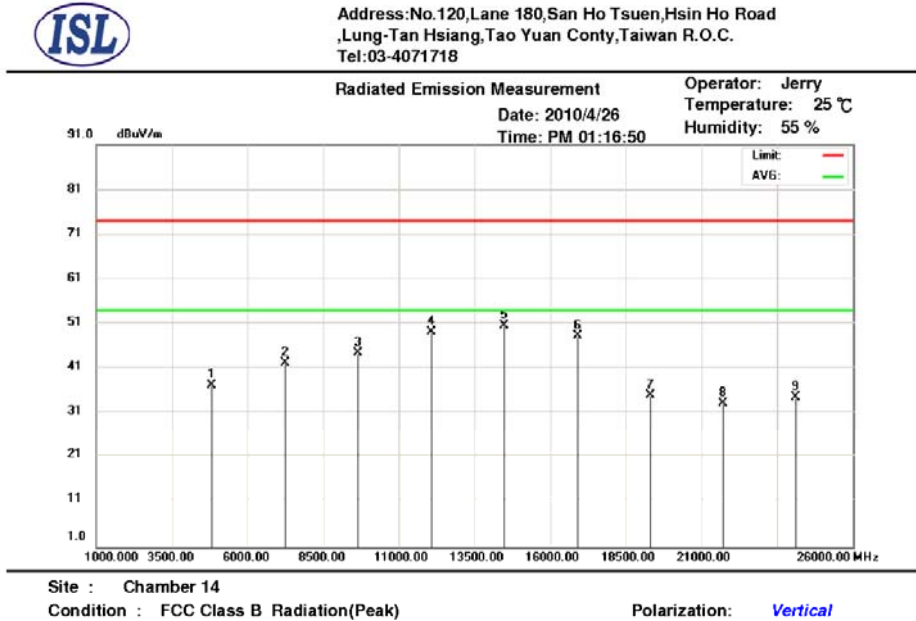

Mk.	Frequency (MHz)	RX_R (dBuV/m)	Ant_F (dB)	Cab_L (dB)	PreAmp (dB)	Emission (dBuV/m)	Limit (dBuV/m)	Margin (dB)	Ant.Pos (cm)	Tab.Pos (deg.)	Detector
1	4824.000	36.37	33.34	2.83	35.24	37.30	74.00	-36.70	134	110	peak
2	7236.000	36.55	37.78	3.39	35.45	42.27	74.00	-31.73	100	20	peak
3	9646.000	36.62	39.77	3.93	35.77	44.55	74.00	-29.45	365	249	peak
4	12060.000	38.45	41.44	4.41	35.03	49.27	74.00	-24.73	202	306	peak
5	14472.000	36.27	43.69	4.71	34.06	50.61	74.00	-23.39	384	204	peak
6	16884.000	35.08	41.87	5.28	33.96	48.27	74.00	-25.73	100	52	peak
7	19296.000	31.61	32.02	5.7	34.31	35.02	74.00	-38.98	100	305	peak
8	21708.000	29.55	32.48	6.04	34.72	33.35	74.00	-40.65	121	184	peak
9	24120.000	30.25	33.15	6.42	35.22	34.60	74.00	-39.40	100	247	peak

*:Maximum data x:Over limit !:over margin

Note:

- According to the standards used, Where limits are specified by agencies for both average and peak (or quasi-peak) detection, if the peak (or quasi-peak) measured value complies with the average limit, it is unnecessary to perform an average measurement.
- “peak”: peak mode; “avg”: average mode
- The Spectrum noise level+Correction Factor < Limit - 6 dB
- Margin=Corrected Amplitude - Limit
- Corrected Amplitude=Radiated Amplitude+Antenna Correction Factor+Cable Loss-Pre-Amplifier Gain
- A margin of -8dB means that the emission is 8dB below the limit.

All frequencies from 1GHz to 25 GHz have been tested.

1GHz~ 25 GHz (Horizontal), Middle Channel



Address: No.120, Lane 180, San Ho Tsuen, Hsin Ho Road
Lung-Tan Hsiang, Tao Yuan Conty, Taiwan R.O.C.
Tel: 03-4071718

Radiated Emission Measurement

Operator: Jerry
Temperature: 25 °C
Humidity: 55 %

Date: 2010/4/26

Time: PM 01:23:12

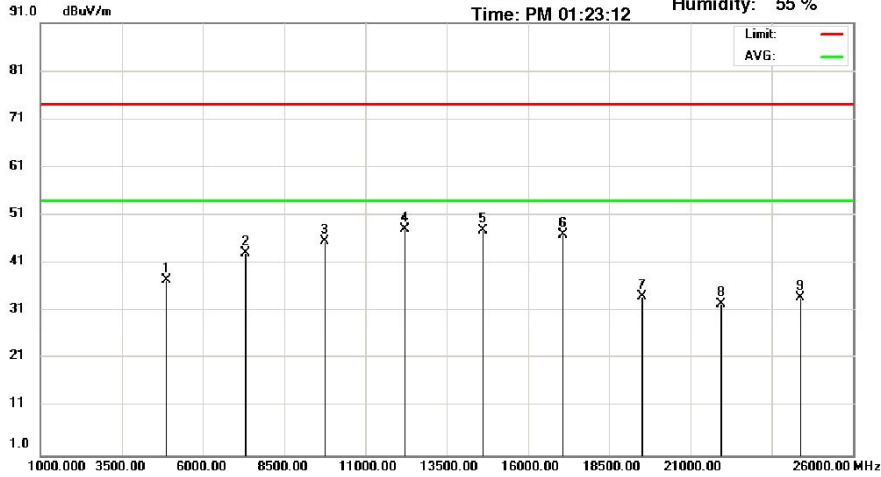

Site : Chamber 14

Condition : FCC Class B Radiation(Peak)

Polarization: *Horizontal*

Mk.	Frequency (MHz)	RX_R (dBuV/m)	Ant_F (dB)	Cab_L (dB)	PreAmp (dB)	Emission (dBuV/m)	Limit (dBuV/m)	Margin (dB)	Ant.Pos (cm)	Tab.Pos (deg.)	Detector
1	4874.000	36.57	33.47	2.85	35.23	37.66	74.00	-36.34	100	190	peak
2	7311.000	37.44	37.9	3.42	35.46	43.30	74.00	-30.70	341	235	peak
3	9748.000	37.77	39.75	3.95	35.75	45.72	74.00	-28.28	100	166	peak
4	12185.000	37.13	41.51	4.44	34.88	48.20	74.00	-25.80	352	109	peak
5	14622.000	34.03	43.43	4.75	34.22	47.99	74.00	-26.01	281	82	peak
6	17059.000	32.75	42.85	5.31	33.85	47.06	74.00	-26.94	111	344	peak
7	19496.000	30.97	32.1	5.7	34.59	34.18	74.00	-39.82	238	186	peak
8	21933.000	28.73	32.57	6.09	34.86	32.53	74.00	-41.47	100	2	peak
9	24370.000	29.91	33.25	6.47	35.67	33.96	74.00	-40.04	281	27	peak

*:Maximum data x:Over limit !:over margin

1GHz~ 25 GHz (Vertical), Middle Channel

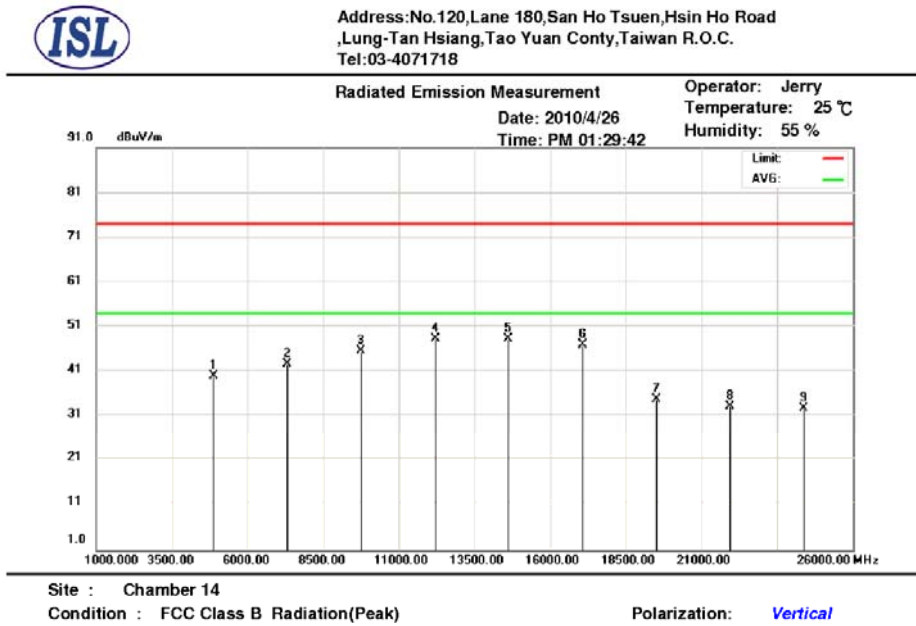

Mk.	Frequency (MHz)	RX_R (dBuV/m)	Ant_F (dB)	Cab_L (dB)	PreAmp (dB)	Emission (dBuV/m)	Limit (dBuV/m)	Margin (dB)	Ant.Pos (cm)	Tab.Pos (deg.)	Detector
1	4874.000	39.02	33.47	2.85	35.23	40.11	74.00	-33.89	153	104	peak
2	7311.000	36.98	37.9	3.42	35.46	42.84	74.00	-31.16	377	63	peak
3	9748.000	37.82	39.75	3.95	35.75	45.77	74.00	-28.23	206	179	peak
4	12185.000	37.20	41.51	4.44	34.88	48.27	74.00	-25.73	174	78	peak
5	14622.000	34.33	43.43	4.75	34.22	48.29	74.00	-25.71	356	214	peak
6	17059.000	32.75	42.85	5.31	33.85	47.06	74.00	-26.94	237	168	peak
7	19496.000	31.76	32.1	5.7	34.59	34.97	74.00	-39.03	132	338	peak
8	21933.000	29.51	32.57	6.09	34.86	33.31	74.00	-40.69	348	147	peak
9	24370.000	28.87	33.25	6.47	35.67	32.92	74.00	-41.08	145	310	peak

*:Maximum data x:Over limit !:over margin

Note:

- According to the standards used, where limits are specified by agencies for both average and peak (or quasi-peak) detection, if the peak (or quasi-peak) measured value complies with the average limit, it is unnecessary to perform an average measurement.
- “peak”: peak mode; “avg”: average mode
- The Spectrum noise level+Correction Factor < Limit - 6 dB
- Margin=Corrected Amplitude - Limit
- Corrected Amplitude=Radiated Amplitude+Antenna Correction Factor+Cable Loss-Pre-Amplifier Gain
- A margin of -8dB means that the emission is 8dB below the limit.

All frequencies from 1GHz to 25 GHz have been tested.

1GHz~ 25 GHz (Horizontal), Highest Channel

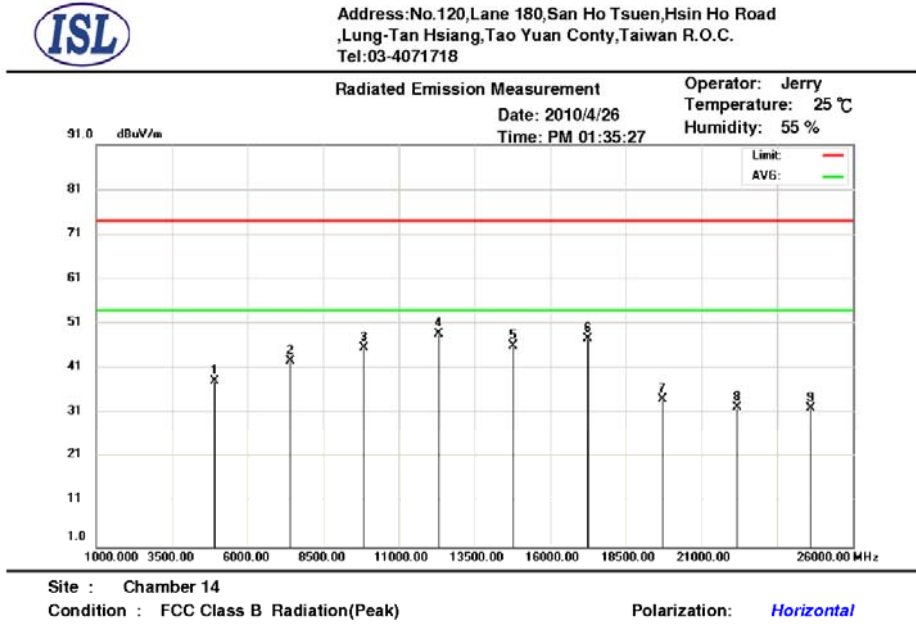

Mk.	Frequency (MHz)	RX_R (dBuV/m)	Ant_F (dB)	Cab_L (dB)	PreAmp (dB)	Emission (dBuV/m)	Limit (dBuV/m)	Margin (dB)	Ant.Pos (cm)	Tab.Pos (deg.)	Detector
1	4924.000	36.91	33.6	2.87	35.22	38.16	74.00	-35.84	263	30	peak
2	7386.000	36.81	38.02	3.45	35.48	42.80	74.00	-31.20	390	9	peak
3	9848.000	37.72	39.73	3.97	35.73	45.69	74.00	-28.31	398	74	peak
4	12310.000	37.58	41.59	4.46	34.73	48.90	74.00	-25.10	249	94	peak
5	14772.000	32.66	42.98	4.81	34.37	46.08	74.00	-27.92	397	358	peak
6	17234.000	32.53	43.9	5.35	33.99	47.79	74.00	-26.21	162	115	peak
7	19696.000	31.05	32.1	5.74	34.76	34.13	74.00	-39.87	100	347	peak
8	22158.000	28.66	32.66	6.1	34.99	32.43	74.00	-41.57	100	267	peak
9	24620.000	28.18	33.37	6.52	35.8	32.27	74.00	-41.73	361	103	peak

*:Maximum data x:Over limit !:over margin

1GHz~ 25 GHz (Vertical), Highest Channel

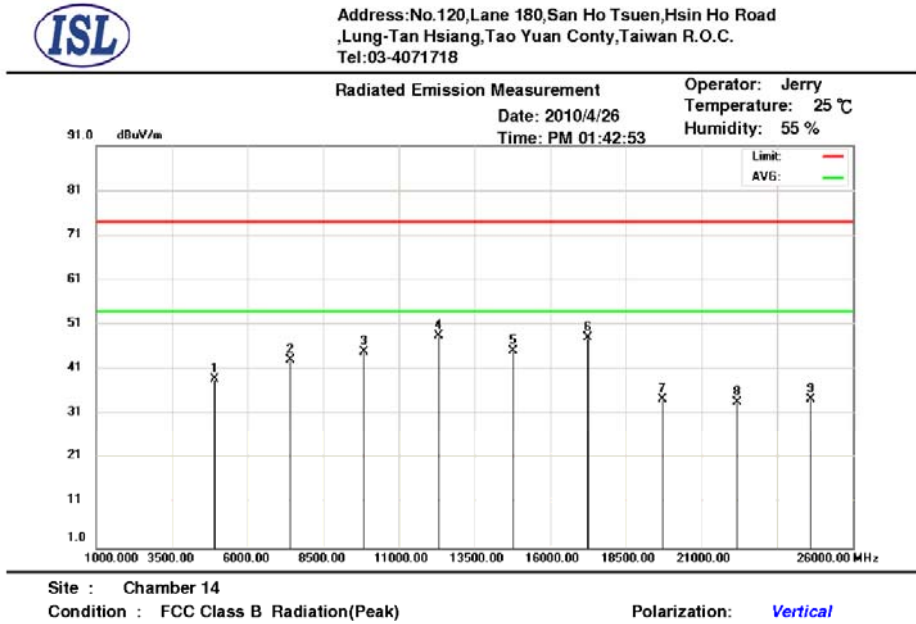

Mk.	Frequency (MHz)	RX_R (dBuV/m)	Ant_F (dB)	Cab_L (dB)	PreAmp (dB)	Emission (dBuV/m)	Limit (dBuV/m)	Margin (dB)	Ant.Pos (cm)	Tab.Pos (deg.)	Detector
1	4924.000	37.63	33.6	2.87	35.22	38.88	74.00	-35.12	100	304	peak
2	7386.000	37.25	38.02	3.45	35.48	43.24	74.00	-30.76	378	69	peak
3	9848.000	36.91	39.73	3.97	35.73	44.88	74.00	-29.12	173	215	peak
4	12310.000	37.16	41.59	4.46	34.73	48.48	74.00	-25.52	119	63	peak
5	14772.000	31.71	42.98	4.81	34.37	45.13	74.00	-28.87	100	130	peak
6	17234.000	32.82	43.9	5.35	33.99	48.08	74.00	-25.92	288	66	peak
7	19696.000	31.40	32.1	5.74	34.76	34.48	74.00	-39.52	305	10	peak
8	22158.000	29.95	32.66	6.1	34.99	33.72	74.00	-40.28	100	284	peak
9	24620.000	30.35	33.37	6.52	35.8	34.44	74.00	-39.56	226	25	peak

*:Maximum data x:Over limit !:over margin

Note:

- According to the standards used, where limits are specified by agencies for both average and peak (or quasi-peak) detection, if the peak (or quasi-peak) measured value complies with the average limit, it is unnecessary to perform an average measurement.
- “peak”: peak mode; “avg”: average mode
- The Spectrum noise level+Correction Factor < Limit - 6 dB
- Margin=Corrected Amplitude - Limit
- Corrected Amplitude=Radiated Amplitude+Antenna Correction Factor+Cable Loss-Pre-Amplifier Gain
- A margin of -8dB means that the emission is 8dB below the limit.

All frequencies from 1GHz to 25 GHz have been tested.

4.3.5 802.11g Test Data

30M – 1GHz Open Field Radiated Emissions (Horizontal) Lowest, Middle, Highest channel

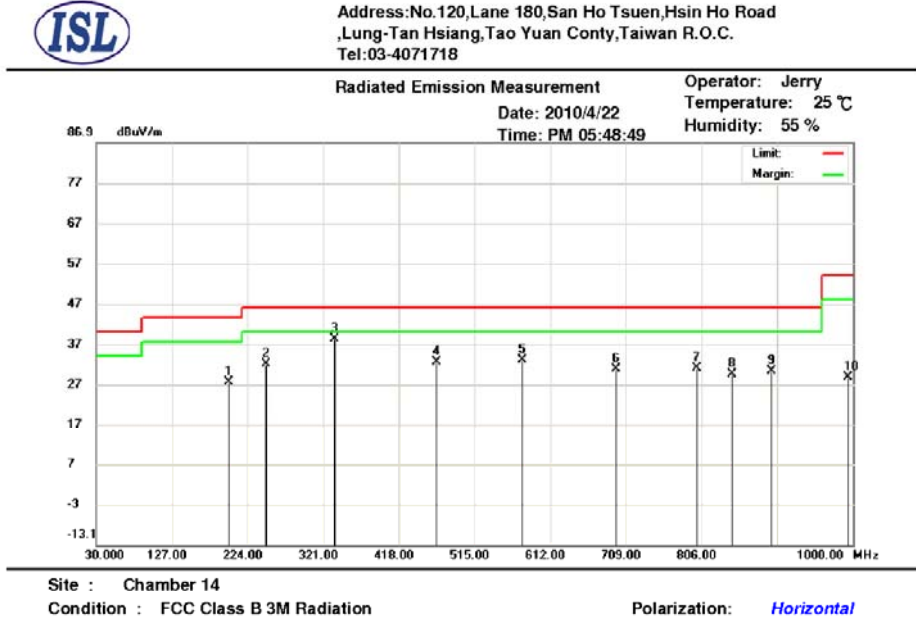

Mk.	Frequency (MHz)	RX_R (dBuV/m)	Ant_F (dB)	Cab_L (dB)	PreAmp (dB)	Emission (dBuV/m)	Limit (dBuV/m)	Margin (dB)	Ant.Pos (cm)	Tab.Pos (deg.)	Detector
1	199.7500	47.36	10.28	0.9	31.02	27.52	43.50	-15.98	367	315	peak
2	248.2500	49.24	12.66	1	30.88	32.02	46.00	-13.98	208	58	peak
3	335.5500	53.05	14.8	1.07	30.71	38.21	46.00	-7.79	272	270	peak
4	466.5000	44.51	17.3	1.3	30.59	32.52	46.00	-13.48	342	67	peak
5	576.1100	43.20	18.86	1.45	30.56	32.95	46.00	-13.05	100	266	peak
6	696.3900	40.06	19.58	1.59	30.5	30.73	46.00	-15.27	124	143	peak
7	800.1800	39.22	20.6	1.7	30.54	30.98	46.00	-15.02	100	342	peak
8	844.8000	36.97	21.14	1.79	30.48	29.42	46.00	-16.58	244	237	peak
9	895.2400	37.34	21.47	1.8	30.42	30.19	46.00	-15.81	238	125	peak
10	994.1800	34.82	22.18	1.99	30.33	28.66	54.00	-25.34	282	65	peak

*:Maximum data x:Over limit !:over margin

30M – 1GHz Open Field Radiated Emissions (Vertical) Lowest, Middle, Highest channel

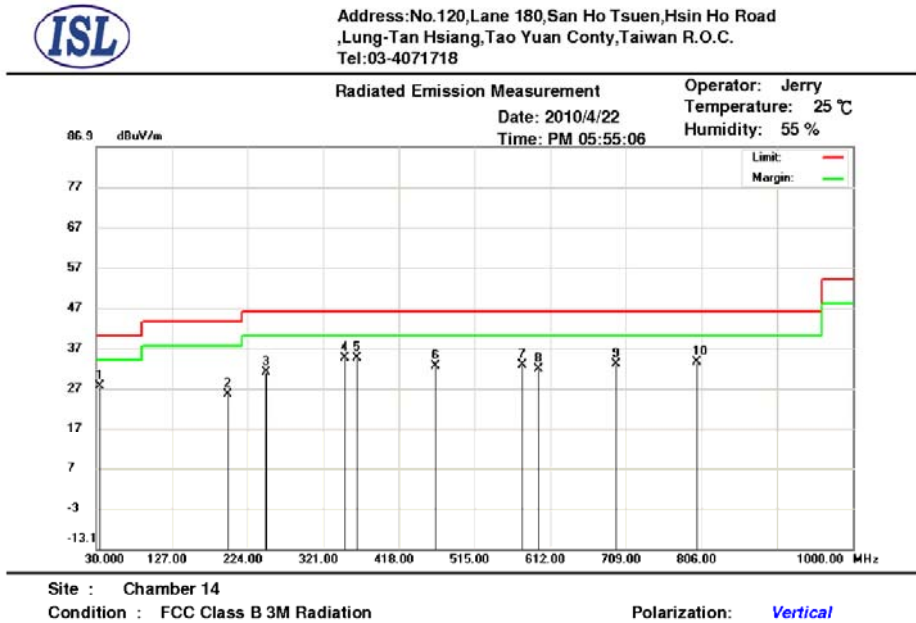

Mk.	Frequency (MHz)	RX_R (dBuV/m)	Ant_F (dB)	Cab_L (dB)	PreAmp (dB)	Emission (dBuV/m)	Limit (dBuV/m)	Margin (dB)	Ant.Pos (cm)	Tab.Pos (deg.)	Detector
1	33.8800	40.90	17.37	0.4	31.1	27.57	40.00	-12.43	221	155	peak
2	198.7800	45.55	10.21	0.9	31.02	25.64	43.50	-17.86	256	65	peak
3	248.2500	48.16	12.66	1	30.88	30.94	46.00	-15.06	239	306	peak
4	348.1600	48.88	15.15	1.1	30.71	34.42	46.00	-11.58	287	53	peak
5	364.6500	48.46	15.58	1.13	30.71	34.46	46.00	-11.54	257	183	peak
6	464.5600	44.63	17.27	1.3	30.6	32.60	46.00	-13.40	223	273	peak
7	576.1100	43.11	18.86	1.45	30.56	32.86	46.00	-13.14	258	14	peak
8	596.4800	41.98	18.98	1.49	30.56	31.89	46.00	-14.11	251	142	peak
9	696.3900	42.36	19.58	1.59	30.5	33.03	46.00	-12.97	367	200	peak
10	800.1800	41.85	20.6	1.7	30.54	33.61	46.00	-12.39	350	355	peak

*:Maximum data x:Over limit !:over margin

NOTE:

- During the Pre-test, the EUT has been tested for Channel Lowest, Middle, Highest transmit from Main and Aux antenna respectively to get all the critical emission frequencies. In the final test all the critical emission frequencies has been tested and the test data are listed above.

- Margin = Corrected Amplitude – Limit

Corrected Amplitude = Radiated Amplitude + Antenna Correction Factor + Cable Loss - Pre-Amplifier Gain

A margin of -8dB means that the emission is 8dB below the limit

All frequencies from 30MHz to 1GHz have been tested

1GHz~ 25 GHz (Horizontal), Lowest Channel



Address: No.120, Lane 180, San Ho Tsuen, Hsin Ho Road
, Lung-Tan Hsiang, Tao Yuan Conty, Taiwan R.O.C.
Tel: 03-4071718

Radiated Emission Measurement

Date: 2010/4/26

Time: PM 01:48:06

Operator: Jerry

Temperature: 25 °C

Humidity: 55 %

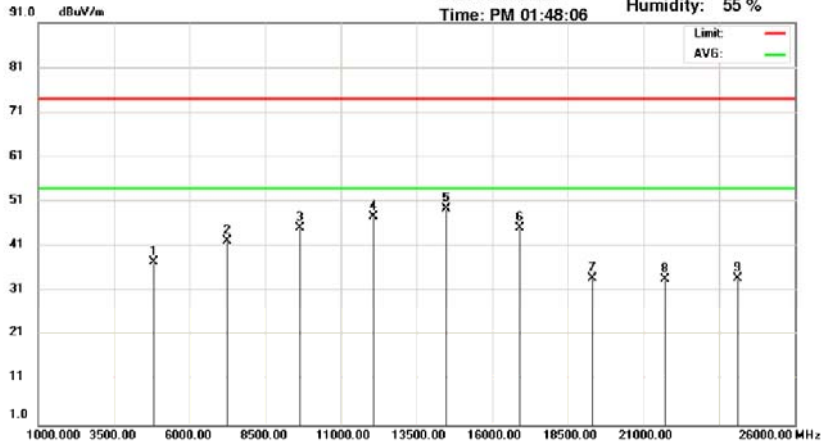

Site : Chamber 14

Condition : FCC Class B Radiation(Peak)

Polarization: Horizontal

Mk.	Frequency (MHz)	RX_R (dBuV/m)	Ant F (dB)	Cab L (dB)	PreAmp (dB)	Emission (dBuV/m)	Limit (dBuV/m)	Margin (dB)	Ant.Pos (cm)	Tab.Pos (deg.)	Detector
1	4824.000	36.73	33.34	2.83	35.24	37.66	74.00	-36.34	100	15	peak
2	7236.000	36.56	37.78	3.39	35.45	42.28	74.00	-31.72	329	248	peak
3	9646.000	37.33	39.77	3.93	35.77	45.26	74.00	-28.74	313	262	peak
4	12060.000	36.89	41.44	4.41	35.03	47.71	74.00	-26.29	214	171	peak
5	14472.000	35.17	43.69	4.71	34.06	49.51	74.00	-24.49	215	91	peak
6	16884.000	32.09	41.87	5.28	33.96	45.28	74.00	-28.72	392	261	peak
7	19296.000	30.65	32.02	5.7	34.31	34.06	74.00	-39.94	100	109	peak
8	21708.000	30.00	32.48	6.04	34.72	33.80	74.00	-40.20	108	354	peak
9	24120.000	29.71	33.15	6.42	35.22	34.06	74.00	-39.94	295	216	peak

*:Maximum data x:Over limit !:over margin

1GHz~ 25 GHz (Vertical), Lowest Channel

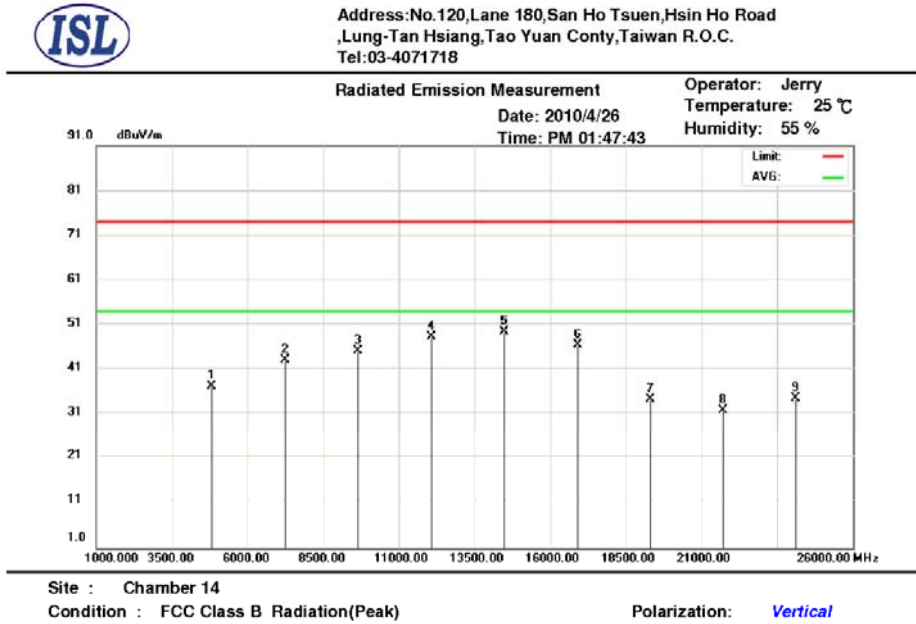

Mk.	Frequency (MHz)	RX_R (dBuV/m)	Ant_F (dB)	Cab_L (dB)	PreAmp (dB)	Emission (dBuV/m)	Limit (dBuV/m)	Margin (dB)	Ant.Pos (cm)	Tab.Pos (deg.)	Detector
1	4824.000	36.32	33.34	2.83	35.24	37.25	74.00	-36.75	323	234	peak
2	7236.000	37.48	37.78	3.39	35.45	43.20	74.00	-30.80	335	350	peak
3	9646.000	37.36	39.77	3.93	35.77	45.29	74.00	-28.71	350	293	peak
4	12060.000	37.47	41.44	4.41	35.03	48.29	74.00	-25.71	170	253	peak
5	14472.000	35.16	43.69	4.71	34.06	49.50	74.00	-24.50	100	342	peak
6	16884.000	33.38	41.87	5.28	33.96	46.57	74.00	-27.43	333	188	peak
7	19296.000	31.06	32.02	5.7	34.31	34.47	74.00	-39.53	269	208	peak
8	21708.000	28.18	32.48	6.04	34.72	31.98	74.00	-42.02	234	148	peak
9	24120.000	30.23	33.15	6.42	35.22	34.58	74.00	-39.42	100	99	peak

*:Maximum data x:Over limit !:over margin

Note:

- According to the standards used, Where limits are specified by agencies for both average and peak (or quasi-peak) detection, if the peak (or quasi-peak) measured value complies with the average limit, it is unnecessary to perform an average measurement.
- “peak”: peak mode; “avg”: average mode
- The Spectrum noise level+Correction Factor < Limit - 6 dB
- Margin=Corrected Amplitude - Limit
- Corrected Amplitude=Radiated Amplitude+Antenna Correction Factor+Cable Loss-Pre-Amplifier Gain
- A margin of -8dB means that the emission is 8dB below the limit.

All frequencies from 1GHz to 25 GHz have been tested.

1GHz~ 25 GHz (Horizontal) , Middle Channel

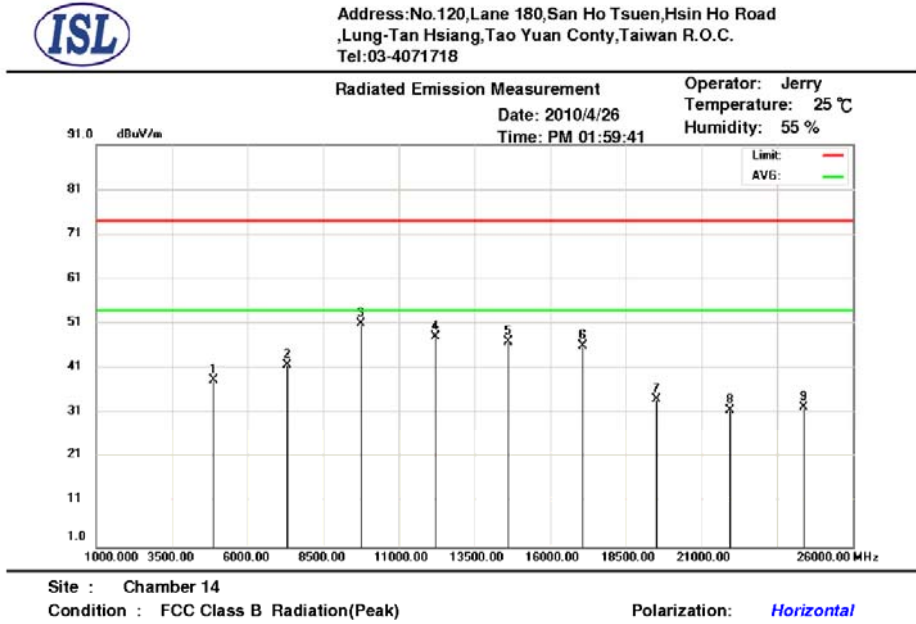

Mk.	Frequency (MHz)	RX_R (dBuV/m)	Ant_F (dB)	Cab_L (dB)	PreAmp (dB)	Emission (dBuV/m)	Limit (dBuV/m)	Margin (dB)	Ant.Pos (cm)	Tab.Pos (deg.)	Detector
1	4874.000	37.30	33.47	2.85	35.23	38.39	74.00	-35.61	100	149	peak
2	7311.000	36.01	37.9	3.42	35.46	41.87	74.00	-32.13	323	49	peak
3	9748.000	43.17	39.75	3.95	35.75	51.12	74.00	-22.88	172	305	peak
4	12185.000	36.99	41.51	4.44	34.88	48.06	74.00	-25.94	392	222	peak
5	14622.000	33.11	43.43	4.75	34.22	47.07	74.00	-26.93	154	114	peak
6	17059.000	31.89	42.85	5.31	33.85	46.20	74.00	-27.80	100	12	peak
7	19496.000	31.01	32.1	5.7	34.59	34.22	74.00	-39.78	115	359	peak
8	21933.000	28.02	32.57	6.09	34.86	31.82	74.00	-42.18	137	293	peak
9	24370.000	28.39	33.25	6.47	35.67	32.44	74.00	-41.56	100	22	peak

*:Maximum data x:Over limit !:over margin

1GHz~ 25 GHz (Vertical), Middle Channel

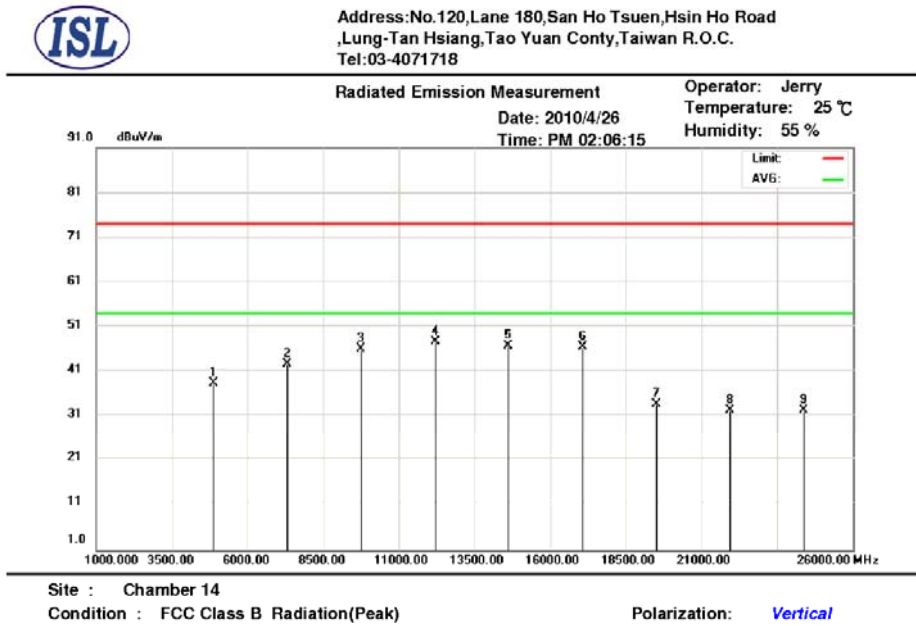

Mk.	Frequency (MHz)	RX_R (dBuV/m)	Ant_F (dB)	Cab_L (dB)	PreAmp (dB)	Emission (dBuV/m)	Limit (dBuV/m)	Margin (dB)	Ant.Pos (cm)	Tab.Pos (deg.)	Detector
1	4874.000	37.33	33.47	2.85	35.23	38.42	74.00	-35.58	327	116	peak
2	7311.000	36.83	37.9	3.42	35.46	42.69	74.00	-31.31	238	28	peak
3	9748.000	38.14	39.75	3.95	35.75	46.09	74.00	-27.91	192	314	peak
4	12185.000	36.57	41.51	4.44	34.88	47.64	74.00	-26.36	100	159	peak
5	14622.000	32.93	43.43	4.75	34.22	46.89	74.00	-27.11	180	62	peak
6	17059.000	32.23	42.85	5.31	33.85	46.54	74.00	-27.46	352	137	peak
7	19496.000	30.56	32.1	5.7	34.59	33.77	74.00	-40.23	100	186	peak
8	21933.000	28.48	32.57	6.09	34.86	32.28	74.00	-41.72	100	100	peak
9	24370.000	28.28	33.25	6.47	35.67	32.33	74.00	-41.67	258	325	peak

*:Maximum data x:Over limit !:over margin

Note:

- According to the standards used, Where limits are specified by agencies for both average and peak (or quasi-peak) detection, if the peak (or quasi-peak) measured value complies with the average limit, it is unnecessary to perform an average measurement.
- “peak”: peak mode; “avg”: average mode
- The Spectrum noise level+Correction Factor < Limit - 6 dB
- Margin=Corrected Amplitude - Limit
- Corrected Amplitude=Radiated Amplitude+Antenna Correction Factor+Cable Loss-Pre-Amplifier Gain
- A margin of -8dB means that the emission is 8dB below the limit.

All frequencies from 1GHz to 25 GHz have been tested.

1GHz~ 25 GHz (Horizontal), Highest Channel

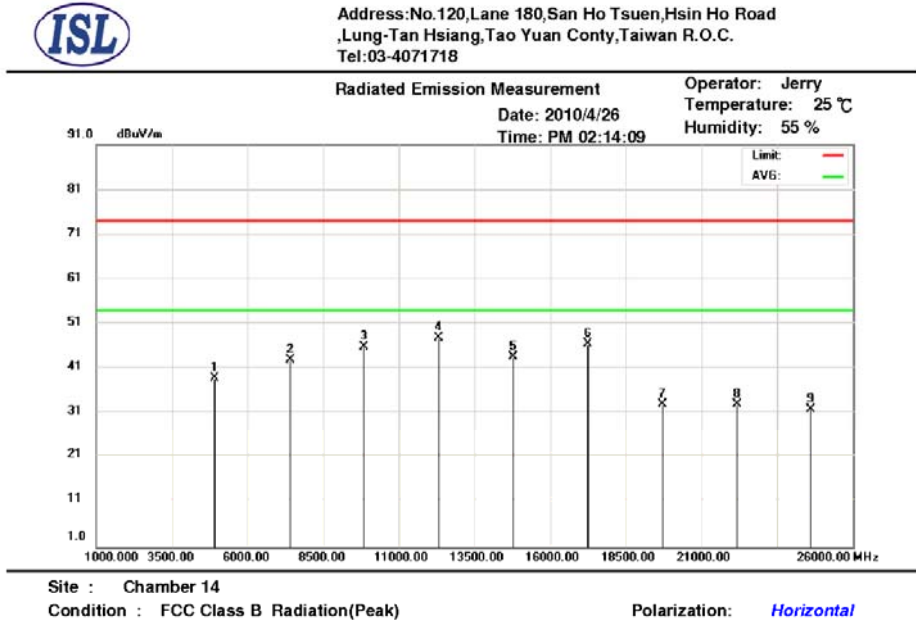

Mk.	Frequency (MHz)	RX_R (dBuV/m)	Ant_F (dB)	Cab_L (dB)	PreAmp (dB)	Emission (dBuV/m)	Limit (dBuV/m)	Margin (dB)	Ant.Pos (cm)	Tab.Pos (deg.)	Detector
1	4924.000	37.74	33.6	2.87	35.22	38.99	74.00	-35.01	100	243	peak
2	7386.000	36.95	38.02	3.45	35.48	42.94	74.00	-31.06	317	121	peak
3	9848.000	37.91	39.73	3.97	35.73	45.88	74.00	-28.12	295	100	peak
4	12310.000	36.70	41.59	4.46	34.73	48.02	74.00	-25.98	296	160	peak
5	14772.000	30.28	42.98	4.81	34.37	43.70	74.00	-30.30	106	220	peak
6	17234.000	31.25	43.9	5.35	33.99	46.51	74.00	-27.49	139	60	peak
7	19696.000	29.87	32.1	5.74	34.76	32.95	74.00	-41.05	352	143	peak
8	22158.000	29.19	32.66	6.1	34.99	32.96	74.00	-41.04	281	229	peak
9	24620.000	27.88	33.37	6.52	35.8	31.97	74.00	-42.03	100	311	peak

*:Maximum data x:Over limit !:over margin

1GHz~ 25 GHz (Vertical), Highest Channel

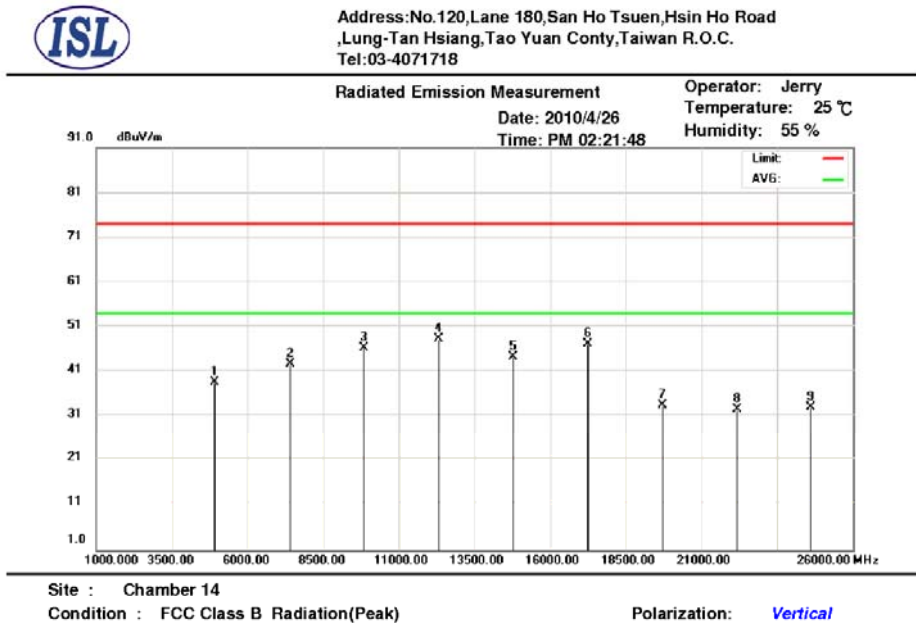

Mk.	Frequency (MHz)	RX_R (dBuV/m)	Ant_F (dB)	Cab_L (dB)	PreAmp (dB)	Emission (dBuV/m)	Limit (dBuV/m)	Margin (dB)	Ant.Pos (cm)	Tab.Pos (deg.)	Detector
1	4924.000	37.38	33.6	2.87	35.22	38.63	74.00	-35.37	105	237	peak
2	7386.000	36.76	38.02	3.45	35.48	42.75	74.00	-31.25	238	292	peak
3	9848.000	38.39	39.73	3.97	35.73	46.36	74.00	-27.64	100	29	peak
4	12310.000	37.14	41.59	4.46	34.73	48.46	74.00	-25.54	268	60	peak
5	14772.000	30.93	42.98	4.81	34.37	44.35	74.00	-29.65	100	102	peak
6	17234.000	32.08	43.9	5.35	33.99	47.34	74.00	-26.66	361	175	peak
7	19696.000	30.39	32.1	5.74	34.76	33.47	74.00	-40.53	100	176	peak
8	22158.000	28.89	32.66	6.1	34.99	32.66	74.00	-41.34	108	320	peak
9	24620.000	29.05	33.37	6.52	35.8	33.14	74.00	-40.86	116	14	peak

*:Maximum data x:Over limit !:over margin

Note:

- According to the standards used, Where limits are specified by agencies for both average and peak (or quasi-peak) detection, if the peak (or quasi-peak) measured value complies with the average limit, it is unnecessary to perform an average measurement.
- “peak”: peak mode; “avg”: average mode
- The Spectrum noise level+Correction Factor < Limit - 6 dB
- Margin=Corrected Amplitude - Limit
- Corrected Amplitude=Radiated Amplitude+Antenna Correction Factor+Cable Loss-Pre-Amplifier Gain
- A margin of -8dB means that the emission is 8dB below the limit.

All frequencies from 1GHz to 25 GHz have been tested.

4.3.6 802.11n(HT20) Test Data (30MHz – 1GHz):

30M – 1GHz Open Field Radiated Emissions (Horizontal) Lowest, Middle, Highest channel



Address: No.120, Lane 180, San Ho Tsuen, Hsin Ho Road
Lung-Tan Hsiang, Tao Yuan Conty, Taiwan R.O.C.
Tel: 03-4071718

Radiated Emission Measurement

Operator: Jerry
Temperature: 25 °C
Humidity: 55 %

Date: 2010/4/22
Time: PM 06:04:12

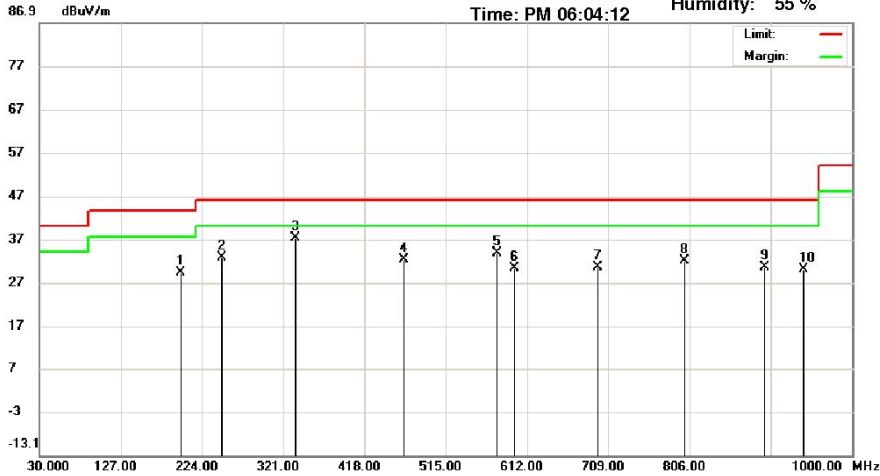

Site : Chamber 14

Condition : FCC Class B 3M Radiation

Polarization: Horizontal

Mk.	Frequency (MHz)	RX_R (dBuV/m)	Ant_F (dB)	Cab_L (dB)	PreAmp (dB)	Emission (dBuV/m)	Limit (dBuV/m)	Margin (dB)	Ant.Pos (cm)	Tab.Pos (deg.)	Detector
1	198.7800	49.13	10.21	0.9	31.02	29.22	43.50	-14.28	100	153	peak
2	248.2500	50.02	12.66	1	30.88	32.80	46.00	-13.20	100	50	peak
3	335.5500	52.10	14.8	1.07	30.71	37.26	46.00	-8.74	171	332	peak
4	464.5600	44.19	17.27	1.3	30.6	32.16	46.00	-13.84	356	351	peak
5	576.1100	44.01	18.86	1.45	30.56	33.76	46.00	-12.24	180	184	peak
6	597.4500	40.32	18.98	1.49	30.56	30.23	46.00	-15.77	376	143	peak
7	696.3900	39.74	19.58	1.59	30.5	30.41	46.00	-15.59	100	247	peak
8	800.1800	40.34	20.6	1.7	30.54	32.10	46.00	-13.90	100	278	peak
9	895.2400	37.66	21.47	1.8	30.42	30.51	46.00	-15.49	100	177	peak
10	942.7700	36.69	21.93	1.89	30.37	30.14	46.00	-15.86	176	84	peak

*:Maximum data x:Over limit !:over margin

30M – 1GHz Open Field Radiated Emissions (Vertical) Lowest, Middle, Highest channel

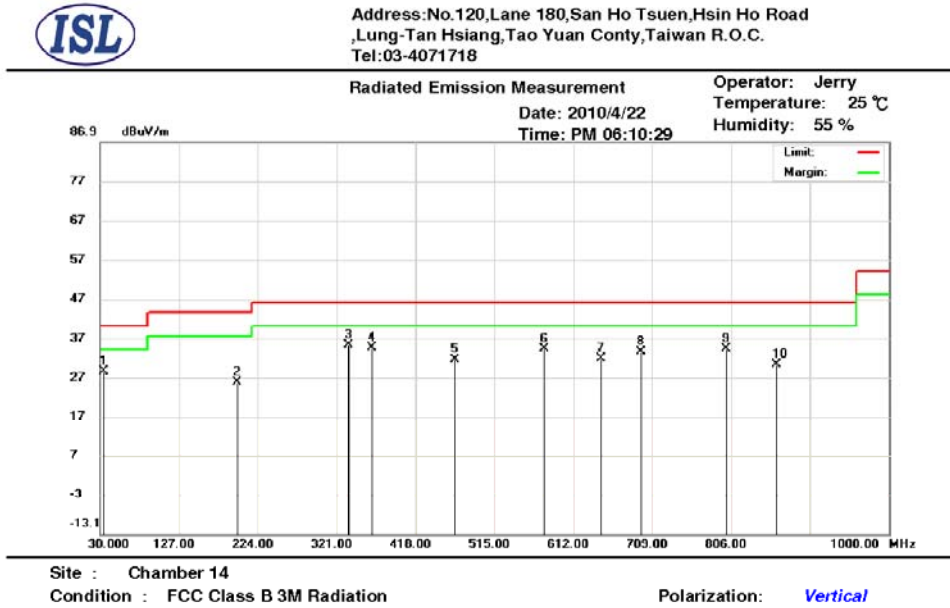

Mk.	Frequency (MHz)	RX_R (dBuV/m)	Ant_F (dB)	Cab_L (dB)	PreAmp (dB)	Emission (dBuV/m)	Limit (dBuV/m)	Margin (dB)	Ant.Pos (cm)	Tab.Pos (deg.)	Detector
1	34.8500	42.40	16.79	0.4	31.11	28.48	40.00	-11.52	263	12	peak
2	198.7800	45.70	10.21	0.9	31.02	25.79	43.50	-17.71	100	24	peak
3	335.5500	50.02	14.8	1.07	30.71	35.18	46.00	-10.82	256	235	peak
4	364.6500	48.50	15.58	1.13	30.71	34.50	46.00	-11.50	312	73	peak
5	466.5000	43.48	17.3	1.3	30.59	31.49	46.00	-14.51	100	202	peak
6	576.1100	44.55	18.86	1.45	30.56	34.30	46.00	-11.70	366	70	peak
7	645.9500	41.42	19.28	1.5	30.53	31.67	46.00	-14.33	294	346	peak
8	695.4200	42.90	19.57	1.59	30.5	33.56	46.00	-12.44	100	71	peak
9	800.1800	42.52	20.6	1.7	30.54	34.28	46.00	-11.72	251	60	peak
10	862.2600	37.73	21.27	1.8	30.46	30.34	46.00	-15.66	103	175	peak

*:Maximum data x:Over limit !:over margin

NOTE:

- During the Pre-test, the EUT has been tested for Lowest, Middle, Highest channel transmit from Main and Aux antenna respectively to get all the critical emission frequencies. In the final test all the critical emission frequencies has been tested and the test data are listed above.
- Margin = Corrected Amplitude – Limit
Corrected Amplitude = Radiated Amplitude + Antenna Correction Factor + Cable Loss - Pre-Amplifier Gain
A margin of -8dB means that the emission is 8dB below the limit

All frequencies from 30MHz to 1GHz have been tested

1GHz~ 25 GHz (Horizontal), Lowest Channel



Address: No.120, Lane 180, San Ho Tsuen, Hsin Ho Road
Lung-Tan Hsiang, Tao Yuan Conty, Taiwan R.O.C.
Tel: 03-4071718

Radiated Emission Measurement

Date: 2010/4/26
Time: PM 02:29:11

Operator: Jerry
Temperature: 25 °C
Humidity: 55 %

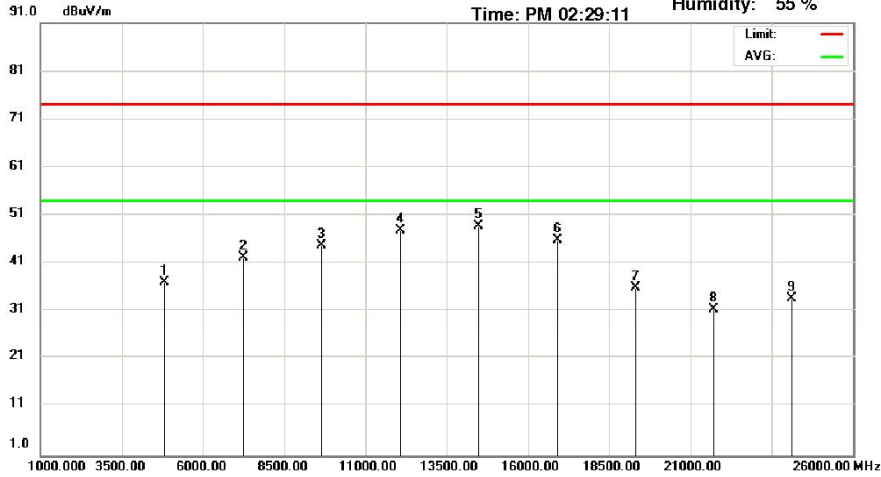

Site : Chamber 14

Condition : FCC Class B Radiation(Peak)

Polarization: *Horizontal*

Mk.	Frequency (MHz)	RX_R (dBuV/m)	Ant_F (dB)	Cab_L (dB)	PreAmp (dB)	Emission (dBuV/m)	Limit (dBuV/m)	Margin (dB)	Ant.Pos (cm)	Tab.Pos (deg.)	Detector
1	4824.000	36.10	33.34	2.83	35.24	37.03	74.00	-36.97	100	62	peak
2	7236.000	36.48	37.78	3.39	35.45	42.20	74.00	-31.80	100	257	peak
3	9646.000	36.77	39.77	3.93	35.77	44.70	74.00	-29.30	100	354	peak
4	12060.000	37.05	41.44	4.41	35.03	47.87	74.00	-26.13	238	65	peak
5	14472.000	34.49	43.69	4.71	34.06	48.83	74.00	-25.17	380	38	peak
6	16884.000	32.70	41.87	5.28	33.96	45.89	74.00	-28.11	154	102	peak
7	19296.000	32.53	32.02	5.7	34.31	35.94	74.00	-38.06	265	179	peak
8	21708.000	27.65	32.48	6.04	34.72	31.45	74.00	-42.55	390	26	peak
9	24120.000	29.42	33.15	6.42	35.22	33.77	74.00	-40.23	100	309	peak

*:Maximum data x:Over limit !:over margin

1GHz~ 25 GHz (Vertical), Lowest Channel

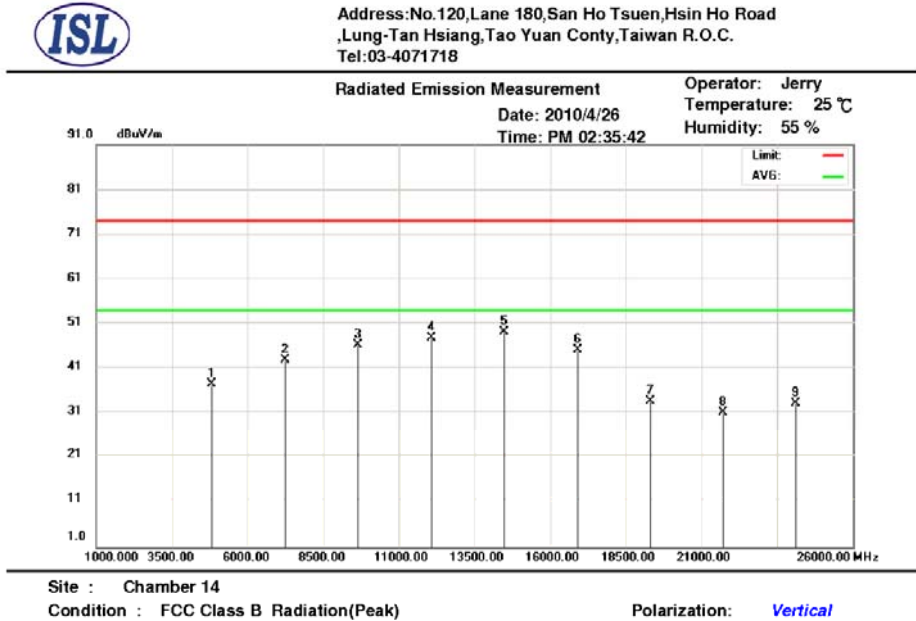

Mk.	Frequency (MHz)	RX_R (dBuV/m)	Ant_F (dB)	Cab_L (dB)	PreAmp (dB)	Emission (dBuV/m)	Limit (dBuV/m)	Margin (dB)	Ant.Pos (cm)	Tab.Pos (deg.)	Detector
1	4824.000	36.71	33.34	2.83	35.24	37.64	74.00	-36.36	146	208	peak
2	7236.000	37.22	37.78	3.39	35.45	42.94	74.00	-31.06	100	85	peak
3	9646.000	38.40	39.77	3.93	35.77	46.33	74.00	-27.67	246	134	peak
4	12060.000	37.06	41.44	4.41	35.03	47.88	74.00	-26.12	100	162	peak
5	14472.000	34.87	43.69	4.71	34.06	49.21	74.00	-24.79	100	170	peak
6	16884.000	32.08	41.87	5.28	33.96	45.27	74.00	-28.73	232	54	peak
7	19296.000	30.26	32.02	5.7	34.31	33.67	74.00	-40.33	111	330	peak
8	21708.000	27.52	32.48	6.04	34.72	31.32	74.00	-42.68	293	171	peak
9	24120.000	29.02	33.15	6.42	35.22	33.37	74.00	-40.63	346	232	peak

*:Maximum data x:Over limit !:over margin

Note:

- According to the standards used, Where limits are specified by agencies for both average and peak (or quasi-peak) detection, if the peak (or quasi-peak) measured value complies with the average limit, it is unnecessary to perform an average measurement.
- “peak”: peak mode; “avg”: average mode
- The Spectrum noise level+Correction Factor < Limit - 6 dB
- Margin=Corrected Amplitude - Limit
- Corrected Amplitude=Radiated Amplitude+Antenna Correction Factor+Cable Loss-Pre-Amplifier Gain
- A margin of -8dB means that the emission is 8dB below the limit.

All frequencies from 1GHz to 25 GHz have been tested.

1GHz~ 25 GHz (Horizontal), Middle Channel



Address: No.120, Lane 180, San Ho Tsuen, Hsin Ho Road
Lung-Tan Hsiang, Tao Yuan Conty, Taiwan R.O.C.
Tel: 03-4071718

Radiated Emission Measurement

Operator: Jerry
Temperature: 25 °C
Humidity: 55 %

Date: 2010/4/26

Time: PM 02:37:44

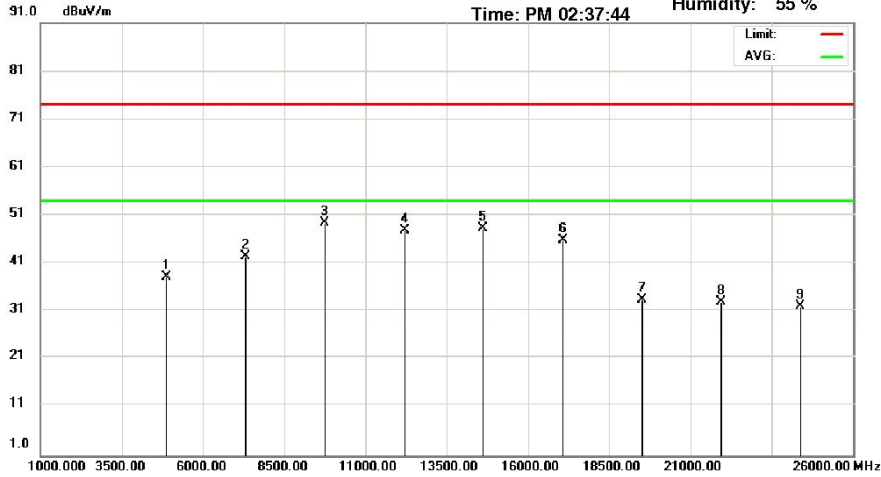

Site : Chamber 14

Condition : FCC Class B Radiation(Peak)

Polarization: Horizontal

Mk.	Frequency (MHz)	RX_R (dBuV/m)	Ant_F (dB)	Cab_L (dB)	PreAmp (dB)	Emission (dBuV/m)	Limit (dBuV/m)	Margin (dB)	Ant.Pos (cm)	Tab.Pos (deg.)	Detector
1	4874.000	37.11	33.47	2.85	35.23	38.20	74.00	-35.80	276	142	peak
2	7311.000	36.73	37.9	3.42	35.46	42.59	74.00	-31.41	100	240	peak
3	9748.000	41.44	39.75	3.95	35.75	49.39	74.00	-24.61	139	270	peak
4	12185.000	36.78	41.51	4.44	34.88	47.85	74.00	-26.15	340	228	peak
5	14622.000	34.46	43.43	4.75	34.22	48.42	74.00	-25.58	277	275	peak
6	17059.000	31.65	42.85	5.31	33.85	45.96	74.00	-28.04	250	34	peak
7	19496.000	30.36	32.1	5.7	34.59	33.57	74.00	-40.43	100	60	peak
8	21933.000	29.26	32.57	6.09	34.86	33.06	74.00	-40.94	315	333	peak
9	24370.000	28.03	33.25	6.47	35.67	32.08	74.00	-41.92	327	90	peak

*:Maximum data x:Over limit !:over margin

1GHz~ 25 GHz (Vertical), Middle Channel

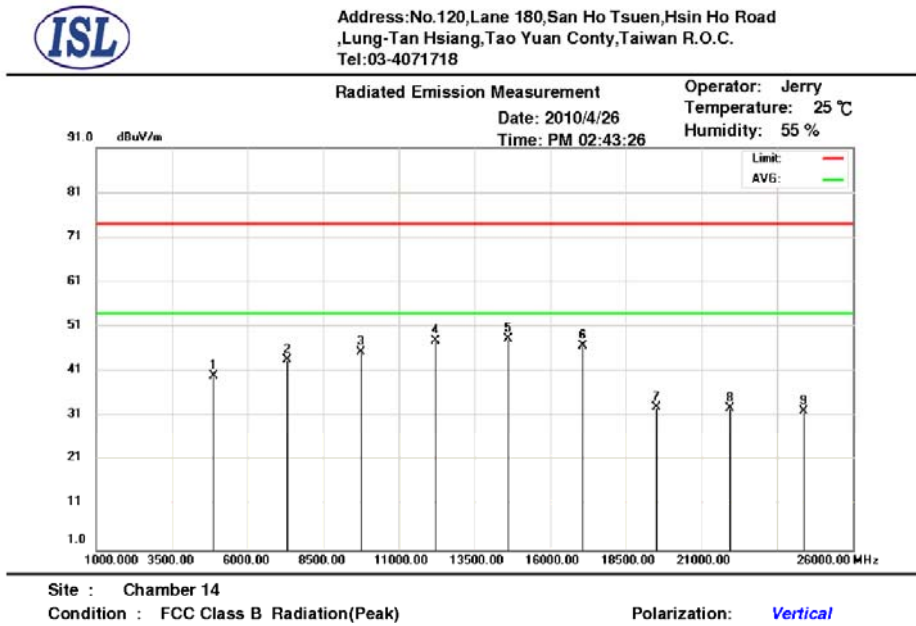

Mk.	Frequency (MHz)	RX_R (dBuV/m)	Ant_F (dB)	Cab_L (dB)	PreAmp (dB)	Emission (dBuV/m)	Limit (dBuV/m)	Margin (dB)	Ant.Pos (cm)	Tab.Pos (deg.)	Detector
1	4874.000	38.91	33.47	2.85	35.23	40.00	74.00	-34.00	100	289	peak
2	7311.000	37.71	37.9	3.42	35.46	43.57	74.00	-30.43	391	68	peak
3	9748.000	37.55	39.75	3.95	35.75	45.50	74.00	-28.50	314	283	peak
4	12185.000	36.83	41.51	4.44	34.88	47.90	74.00	-26.10	209	325	peak
5	14622.000	34.37	43.43	4.75	34.22	48.33	74.00	-25.67	352	47	peak
6	17059.000	32.43	42.85	5.31	33.85	46.74	74.00	-27.26	328	218	peak
7	19496.000	29.75	32.1	5.7	34.59	32.96	74.00	-41.04	320	212	peak
8	21933.000	29.08	32.57	6.09	34.86	32.88	74.00	-41.12	217	350	peak
9	24370.000	28.22	33.25	6.47	35.67	32.27	74.00	-41.73	192	12	peak

*:Maximum data x:Over limit !:over margin

Note:

- According to the standards used, where limits are specified by agencies for both average and peak (or quasi-peak) detection, if the peak (or quasi-peak) measured value complies with the average limit, it is unnecessary to perform an average measurement.
- “peak”: peak mode; “avg”: average mode
- The Spectrum noise level+Correction Factor < Limit - 6 dB
- Margin=Corrected Amplitude - Limit
- Corrected Amplitude=Radiated Amplitude+Antenna Correction Factor+Cable Loss-Pre-Amplifier Gain
- A margin of -8dB means that the emission is 8dB below the limit.

All frequencies from 1GHz to 25 GHz have been tested.

1GHz~ 25 GHz (Horizontal), Highest Channel

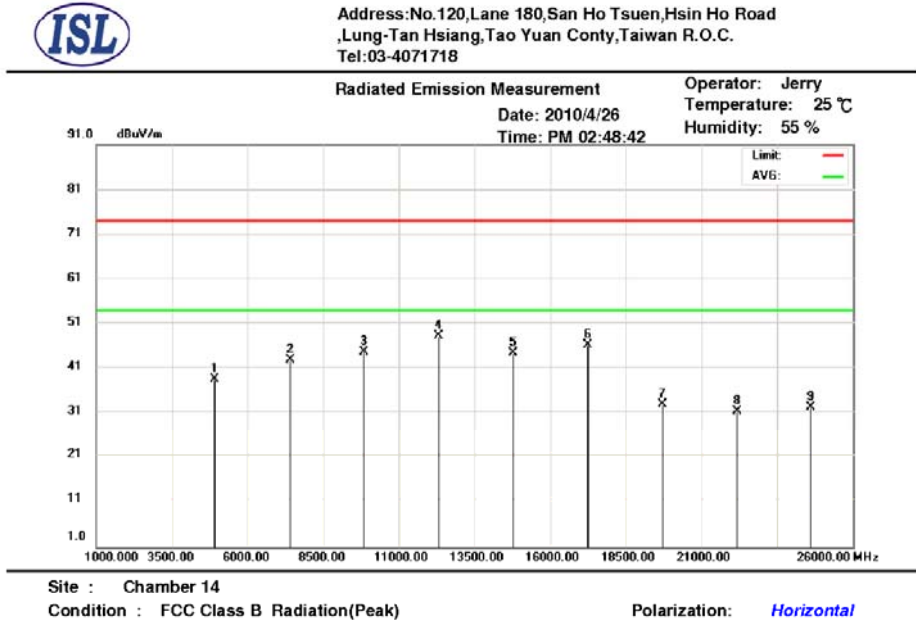

Mk.	Frequency (MHz)	RX_R (dBuV/m)	Ant_F (dB)	Cab_L (dB)	PreAmp (dB)	Emission (dBuV/m)	Limit (dBuV/m)	Margin (dB)	Ant.Pos (cm)	Tab.Pos (deg.)	Detector
1	4924.000	37.55	33.6	2.87	35.22	38.80	74.00	-35.20	165	203	peak
2	7386.000	36.89	38.02	3.45	35.48	42.88	74.00	-31.12	379	128	peak
3	9848.000	36.84	39.73	3.97	35.73	44.81	74.00	-29.19	100	64	peak
4	12310.000	37.13	41.59	4.46	34.73	48.45	74.00	-25.55	100	62	peak
5	14772.000	31.02	42.98	4.81	34.37	44.44	74.00	-29.56	100	179	peak
6	17234.000	31.12	43.9	5.35	33.99	46.38	74.00	-27.62	100	169	peak
7	19696.000	29.87	32.1	5.74	34.76	32.95	74.00	-41.05	215	235	peak
8	22158.000	27.79	32.66	6.1	34.99	31.56	74.00	-42.44	168	135	peak
9	24620.000	28.39	33.37	6.52	35.8	32.48	74.00	-41.52	100	294	peak

*:Maximum data x:Over limit !:over margin

1GHz~ 25 GHz (Vertical), Highest Channel

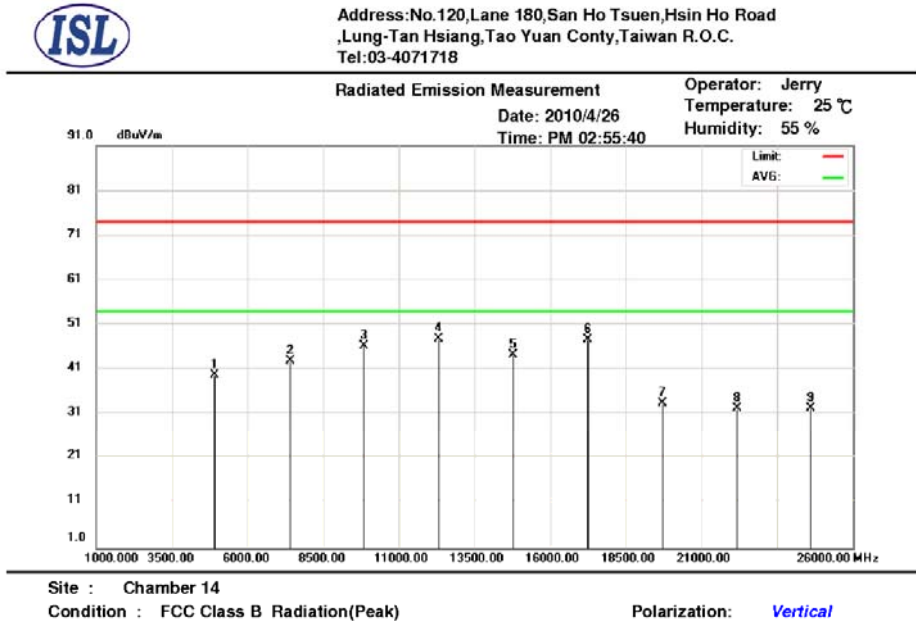

Mk.	Frequency (MHz)	RX_R (dBuV/m)	Ant_F (dB)	Cab_L (dB)	PreAmp (dB)	Emission (dBuV/m)	Limit (dBuV/m)	Margin (dB)	Ant.Pos (cm)	Tab.Pos (deg.)	Detector
1	4924.000	38.66	33.6	2.87	35.22	39.91	74.00	-34.09	100	42	peak
2	7386.000	36.86	38.02	3.45	35.48	42.85	74.00	-31.15	100	262	peak
3	9848.000	38.40	39.73	3.97	35.73	46.37	74.00	-27.63	100	99	peak
4	12310.000	36.69	41.59	4.46	34.73	48.01	74.00	-25.99	328	48	peak
5	14772.000	30.95	42.98	4.81	34.37	44.37	74.00	-29.63	143	96	peak
6	17234.000	32.37	43.9	5.35	33.99	47.63	74.00	-26.37	105	68	peak
7	19696.000	30.46	32.1	5.74	34.76	33.54	74.00	-40.46	387	267	peak
8	22158.000	28.66	32.66	6.1	34.99	32.43	74.00	-41.57	176	40	peak
9	24620.000	28.39	33.37	6.52	35.8	32.48	74.00	-41.52	186	10	peak

*:Maximum data x:Over limit !:over margin

Note:

- According to the standards used, where limits are specified by agencies for both average and peak (or quasi-peak) detection, if the peak (or quasi-peak) measured value complies with the average limit, it is unnecessary to perform an average measurement.
- “peak”: peak mode; “avg”: average mode
- The Spectrum noise level+Correction Factor < Limit - 6 dB
- Margin=Corrected Amplitude - Limit
- Corrected Amplitude=Radiated Amplitude+Antenna Correction Factor+Cable Loss-Pre-Amplifier Gain
- A margin of -8dB means that the emission is 8dB below the limit.

All frequencies from 1GHz to 25 GHz have been tested.

4.3.7 802.11n(HT40) Test Data

30M – 1GHz Open Field Radiated Emissions (Horizontal) Lowest, Middle, Highest channel

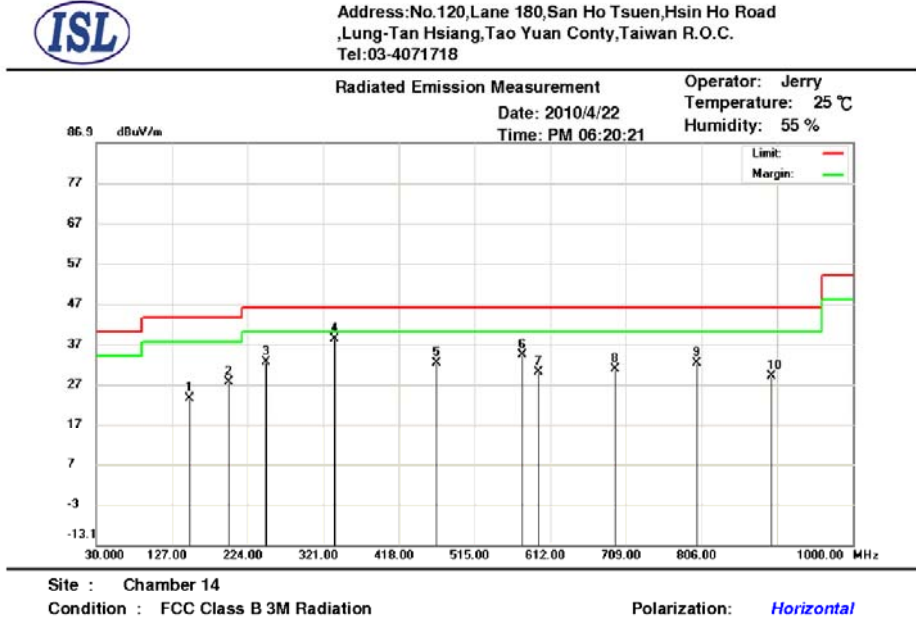

Mk.	Frequency (MHz)	RX_R (dBuV/m)	Ant_F (dB)	Cab_L (dB)	PreAmp (dB)	Emission (dBuV/m)	Limit (dBuV/m)	Margin (dB)	Ant.Pos (cm)	Tab.Pos (deg.)	Detector
1	149.3100	42.82	11.15	0.8	31.16	23.61	43.50	-19.89	398	188	peak
2	199.7500	47.43	10.28	0.9	31.02	27.59	43.50	-15.91	337	346	peak
3	248.2500	49.85	12.66	1	30.88	32.63	46.00	-13.37	343	160	peak
4	335.5500	53.13	14.8	1.07	30.71	38.29	46.00	-7.71	109	172	peak
5	466.5000	44.20	17.3	1.3	30.59	32.21	46.00	-13.79	366	28	peak
6	576.1100	44.48	18.86	1.45	30.56	34.23	46.00	-11.77	353	359	peak
7	596.4800	40.01	18.98	1.49	30.56	29.92	46.00	-16.08	100	182	peak
8	695.4200	40.12	19.57	1.59	30.5	30.78	46.00	-15.22	266	57	peak
9	800.1800	40.51	20.6	1.7	30.54	32.27	46.00	-13.73	302	16	peak
10	896.2100	36.19	21.48	1.8	30.41	29.06	46.00	-16.94	272	158	peak

*:Maximum data x:Over limit !:over margin

30M – 1GHz Open Field Radiated Emissions (Vertical) Lowest, Middle, Highest channel

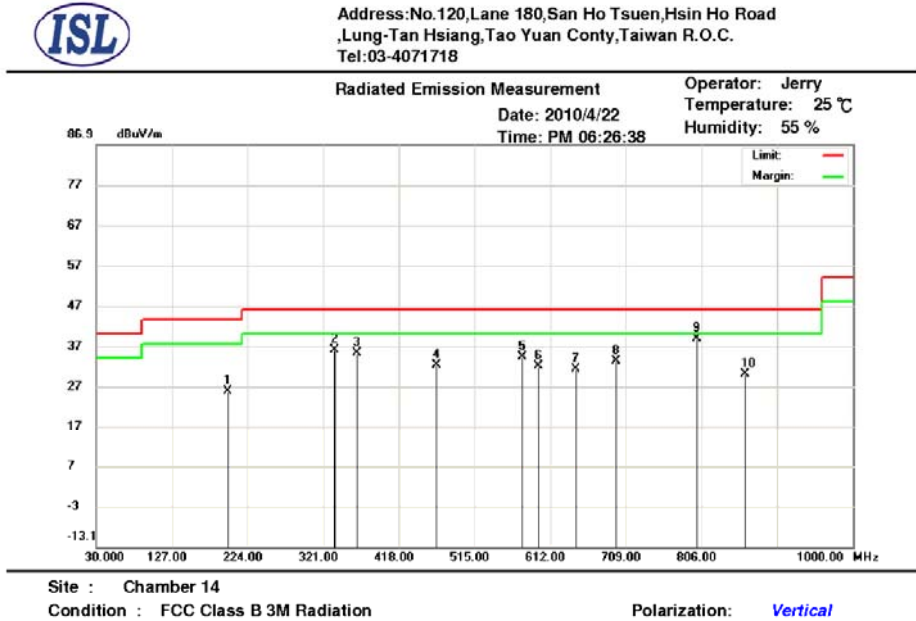

Mk.	Frequency (MHz)	RX_R (dBuV/m)	Ant_F (dB)	Cab_L (dB)	PreAmp (dB)	Emission (dBuV/m)	Limit (dBuV/m)	Margin (dB)	Ant.Pos (cm)	Tab.Pos (deg.)	Detector
1	198.7800	45.75	10.21	0.9	31.02	25.84	43.50	-17.66	287	249	peak
2	335.5500	50.98	14.8	1.07	30.71	36.14	46.00	-9.86	313	234	peak
3	364.6500	49.20	15.58	1.13	30.71	35.20	46.00	-10.80	291	314	peak
4	466.5000	44.23	17.3	1.3	30.59	32.24	46.00	-13.76	200	6	peak
5	576.1100	44.58	18.86	1.45	30.56	34.33	46.00	-11.67	116	164	peak
6	596.4800	42.00	18.98	1.49	30.56	31.91	46.00	-14.09	158	262	peak
7	644.9800	40.98	19.27	1.5	30.53	31.22	46.00	-14.78	208	357	peak
8	696.3900	42.65	19.58	1.59	30.5	33.32	46.00	-12.68	120	347	peak
9	800.1800	46.92	20.6	1.7	30.54	38.68	46.00	-7.32	100	221	peak
10	862.2600	37.35	21.27	1.8	30.46	29.96	46.00	-16.04	142	313	peak

*:Maximum data x:Over limit !:over margin

NOTE:

- During the Pre-test, the EUT has been tested for Channel Lowest, Middle, Highest transmit from Main and Aux antenna respectively to get all the critical emission frequencies. In the final test all the critical emission frequencies has been tested and the test data are listed above.
- Margin = Corrected Amplitude – Limit
Corrected Amplitude = Radiated Amplitude + Antenna Correction Factor + Cable Loss - Pre-Amplifier Gain
A margin of -8dB means that the emission is 8dB below the limit

All frequencies from 30MHz to 1GHz have been tested

1GHz~ 25 GHz (Horizontal), Lowest Channel

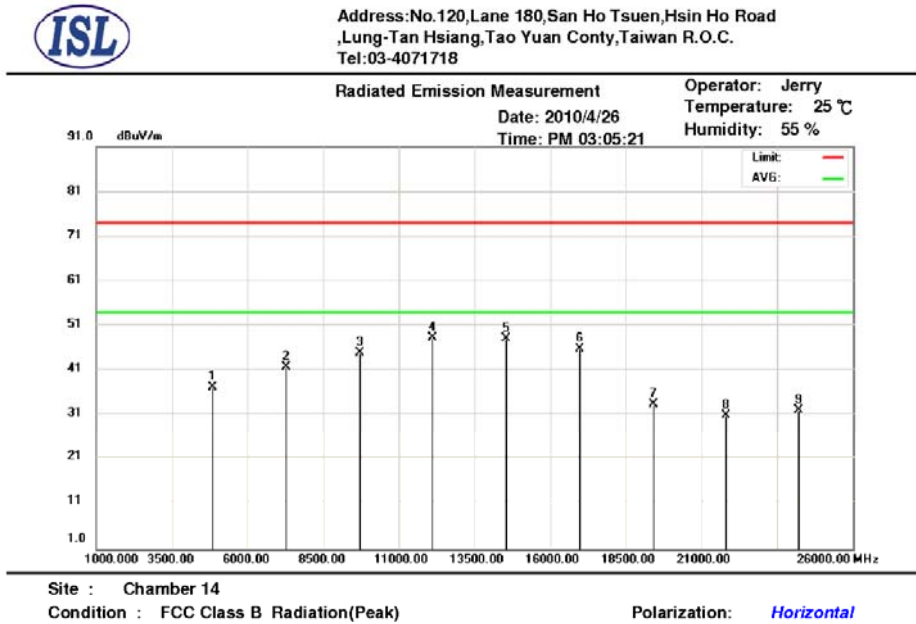

Mk.	Frequency (MHz)	RX_R (dBuV/m)	Ant F (dB)	Cab L (dB)	PreAmp (dB)	Emission (dBuV/m)	Limit (dBuV/m)	Margin (dB)	Ant.Pos (cm)	Tab.Pos (deg.)	Detector
1	4844.000	36.41	33.39	2.84	35.23	37.41	74.00	-36.59	250	160	peak
2	7266.000	36.02	37.83	3.41	35.45	41.81	74.00	-32.19	231	110	peak
3	9686.000	36.97	39.76	3.94	35.76	44.91	74.00	-29.09	175	274	peak
4	12110.000	37.44	41.47	4.42	34.97	48.36	74.00	-25.64	100	155	peak
5	14532.000	33.86	43.7	4.71	34.13	48.14	74.00	-25.86	251	283	peak
6	16954.000	32.15	42.25	5.29	33.86	45.83	74.00	-28.17	388	243	peak
7	19376.000	30.28	32.05	5.7	34.43	33.60	74.00	-40.40	154	1	peak
8	21798.000	27.15	32.52	6.06	34.78	30.95	74.00	-43.05	113	90	peak
9	24220.000	27.98	33.19	6.44	35.4	32.21	74.00	-41.79	301	300	peak

*:Maximum data x:Over limit !:over margin

1GHz~ 25 GHz (Vertical), Lowest Channel

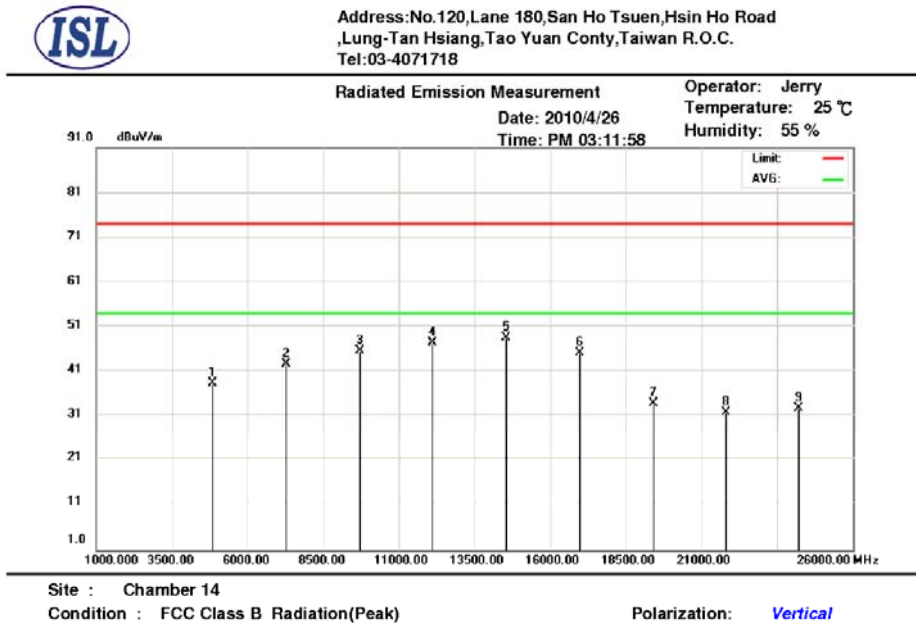

Mk.	Frequency (MHz)	RX_R (dBuV/m)	Ant_F (dB)	Cab_L (dB)	PreAmp (dB)	Emission (dBuV/m)	Limit (dBuV/m)	Margin (dB)	Ant.Pos (cm)	Tab.Pos (deg.)	Detector
1	4844.000	37.54	33.39	2.84	35.23	38.54	74.00	-35.46	100	315	peak
2	7266.000	36.85	37.83	3.41	35.45	42.64	74.00	-31.36	104	147	peak
3	9686.000	37.73	39.76	3.94	35.76	45.67	74.00	-28.33	100	168	peak
4	12110.000	36.45	41.47	4.42	34.97	47.37	74.00	-26.63	100	69	peak
5	14532.000	34.20	43.7	4.71	34.13	48.48	74.00	-25.52	100	248	peak
6	16954.000	31.44	42.25	5.29	33.86	45.12	74.00	-28.88	111	227	peak
7	19376.000	30.75	32.05	5.7	34.43	34.07	74.00	-39.93	100	233	peak
8	21798.000	28.04	32.52	6.06	34.78	31.84	74.00	-42.16	285	276	peak
9	24220.000	28.65	33.19	6.44	35.4	32.88	74.00	-41.12	235	287	peak

*:Maximum data x:Over limit !:over margin

Note:

- According to the standards used, Where limits are specified by agencies for both average and peak (or quasi-peak) detection, if the peak (or quasi-peak) measured value complies with the average limit, it is unnecessary to perform an average measurement.
- “peak”: peak mode; “avg”: average mode
- The Spectrum noise level+Correction Factor < Limit - 6 dB
- Margin=Corrected Amplitude - Limit
- Corrected Amplitude=Radiated Amplitude+Antenna Correction Factor+Cable Loss-Pre-Amplifier Gain
- A margin of -8dB means that the emission is 8dB below the limit.

All frequencies from 1GHz to 25 GHz have been tested.

1GHz~ 25 GHz (Horizontal) , Middle Channel

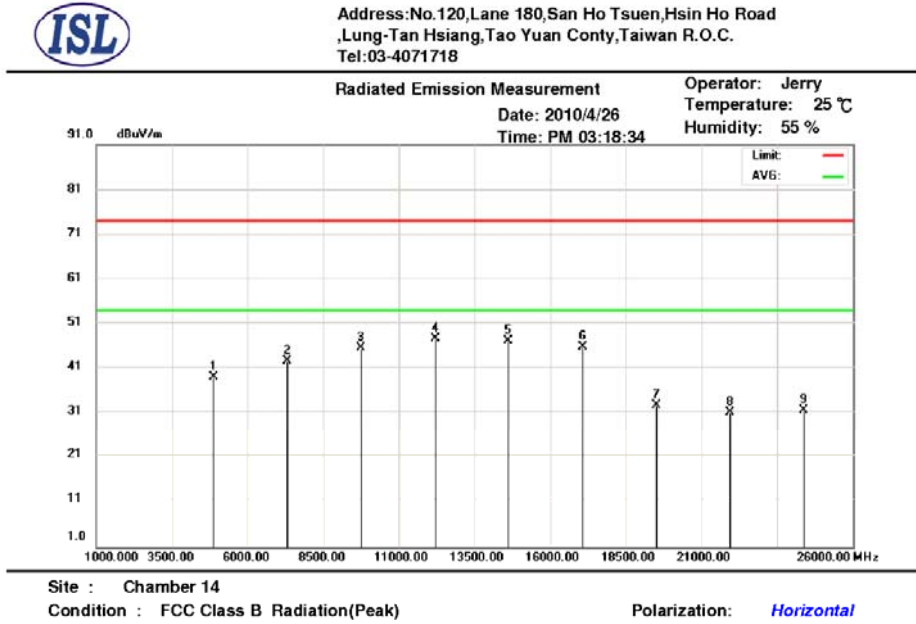

Mk.	Frequency (MHz)	RX_R (dBuV/m)	Ant_F (dB)	Cab_L (dB)	PreAmp (dB)	Emission (dBuV/m)	Limit (dBuV/m)	Margin (dB)	Ant.Pos (cm)	Tab.Pos (deg.)	Detector
1	4874.000	38.06	33.47	2.85	35.23	39.15	74.00	-34.85	160	101	peak
2	7311.000	36.85	37.9	3.42	35.46	42.71	74.00	-31.29	100	335	peak
3	9748.000	37.69	39.75	3.95	35.75	45.64	74.00	-28.36	177	180	peak
4	12185.000	36.73	41.51	4.44	34.88	47.80	74.00	-26.20	320	167	peak
5	14622.000	33.19	43.43	4.75	34.22	47.15	74.00	-26.85	134	20	peak
6	17059.000	31.59	42.85	5.31	33.85	45.90	74.00	-28.10	237	51	peak
7	19496.000	29.66	32.1	5.7	34.59	32.87	74.00	-41.13	332	24	peak
8	21933.000	27.52	32.57	6.09	34.86	31.32	74.00	-42.68	236	61	peak
9	24370.000	27.66	33.25	6.47	35.67	31.71	74.00	-42.29	100	209	peak

*:Maximum data x:Over limit !:over margin

1GHz~ 25 GHz (Vertical), Middle Channel

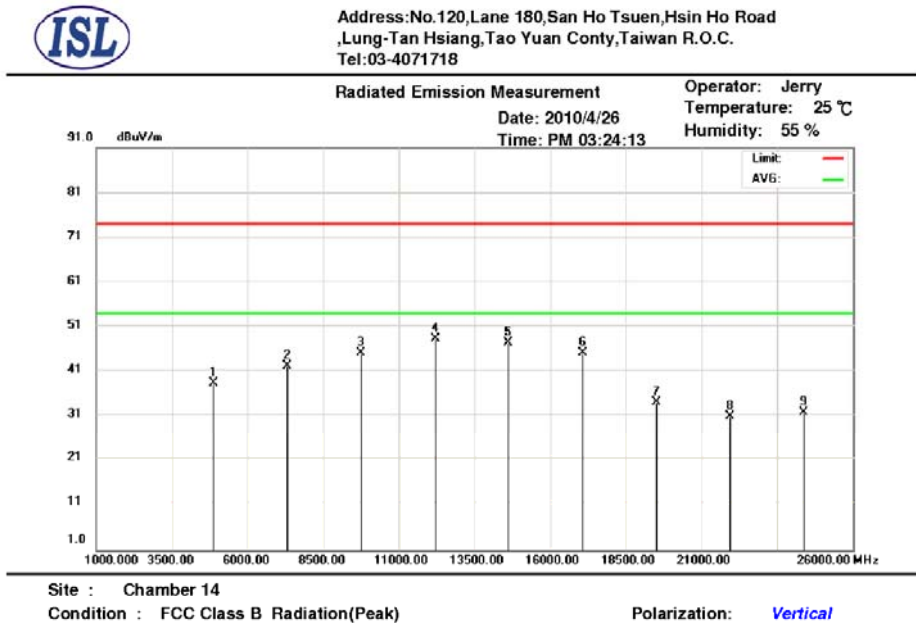

Mk.	Frequency (MHz)	RX_R (dBuV/m)	Ant_F (dB)	Cab_L (dB)	PreAmp (dB)	Emission (dBuV/m)	Limit (dBuV/m)	Margin (dB)	Ant.Pos (cm)	Tab.Pos (deg.)	Detector
1	4874.000	37.39	33.47	2.85	35.23	38.48	74.00	-35.52	304	247	peak
2	7311.000	36.48	37.9	3.42	35.46	42.34	74.00	-31.66	100	35	peak
3	9748.000	37.27	39.75	3.95	35.75	45.22	74.00	-28.78	351	321	peak
4	12185.000	37.22	41.51	4.44	34.88	48.29	74.00	-25.71	141	136	peak
5	14622.000	33.56	43.43	4.75	34.22	47.52	74.00	-26.48	208	24	peak
6	17059.000	30.97	42.85	5.31	33.85	45.28	74.00	-28.72	315	3	peak
7	19496.000	30.96	32.1	5.7	34.59	34.17	74.00	-39.83	178	48	peak
8	21933.000	27.33	32.57	6.09	34.86	31.13	74.00	-42.87	139	206	peak
9	24370.000	27.86	33.25	6.47	35.67	31.91	74.00	-42.09	365	131	peak

*:Maximum data x:Over limit !:over margin

Note:

- According to the standards used, Where limits are specified by agencies for both average and peak (or quasi-peak) detection, if the peak (or quasi-peak) measured value complies with the average limit, it is unnecessary to perform an average measurement.
- “peak”: peak mode; “avg”: average mode
- The Spectrum noise level+Correction Factor < Limit - 6 dB
- Margin=Corrected Amplitude - Limit
- Corrected Amplitude=Radiated Amplitude+Antenna Correction Factor+Cable Loss-Pre-Amplifier Gain
- A margin of -8dB means that the emission is 8dB below the limit.

All frequencies from 1GHz to 25 GHz have been tested.

1GHz~ 25 GHz (Horizontal), Highest Channel

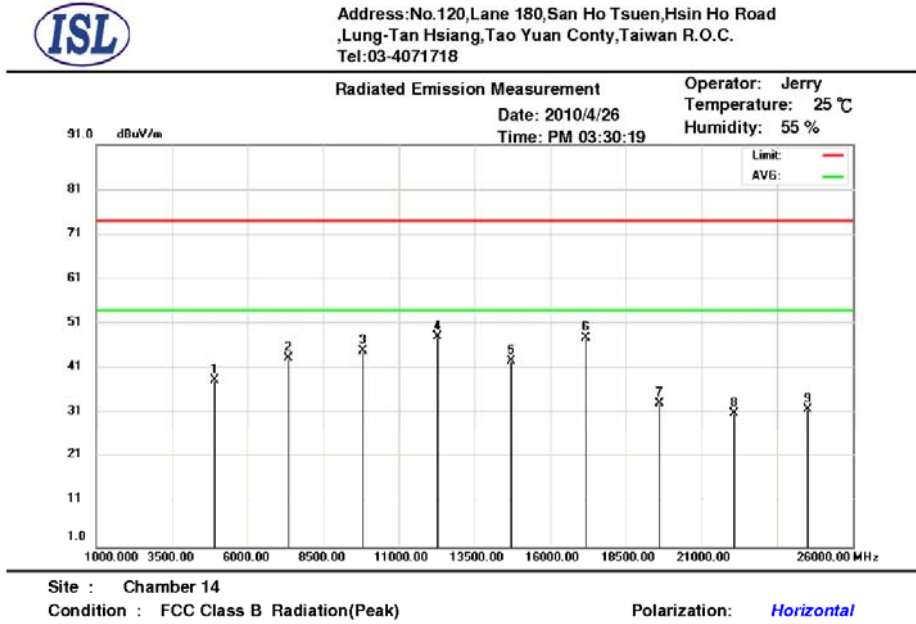

Mk.	Frequency (MHz)	RX_R (dBuV/m)	Ant_F (dB)	Cab_L (dB)	PreAmp (dB)	Emission (dBuV/m)	Limit (dBuV/m)	Margin (dB)	Ant.Pos (cm)	Tab.Pos (deg.)	Detector
1	4904.000	37.21	33.55	2.86	35.22	38.40	74.00	-35.60	100	162	peak
2	7336.000	37.58	37.94	3.43	35.47	43.48	74.00	-30.52	100	223	peak
3	9808.000	36.96	39.74	3.96	35.74	44.92	74.00	-29.08	125	102	peak
4	12260.000	36.86	41.56	4.45	34.79	48.08	74.00	-25.92	100	233	peak
5	14712.000	29.01	43.16	4.78	34.31	42.64	74.00	-31.36	283	156	peak
6	17164.000	33.07	43.48	5.33	33.93	47.95	74.00	-26.05	100	314	peak
7	19616.000	30.25	32.1	5.72	34.69	33.38	74.00	-40.62	100	199	peak
8	22068.000	27.20	32.63	6.1	34.94	30.99	74.00	-43.01	100	223	peak
9	24520.000	28.06	33.31	6.5	35.88	31.99	74.00	-42.01	229	181	peak

*:Maximum data x:Over limit !:over margin

1GHz~ 25 GHz (Vertical), Highest Channel

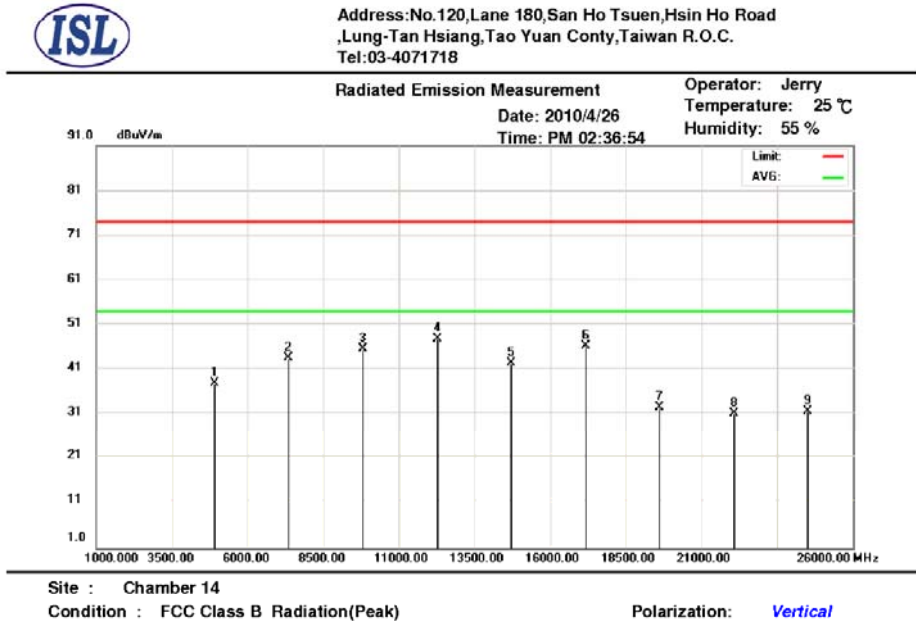

Mk.	Frequency (MHz)	RX_R (dBuV/m)	Ant_F (dB)	Cab_L (dB)	PreAmp (dB)	Emission (dBuV/m)	Limit (dBuV/m)	Margin (dB)	Ant.Pos (cm)	Tab.Pos (deg.)	Detector
1	4904.000	36.92	33.55	2.86	35.22	38.11	74.00	-35.89	255	288	peak
2	7336.000	37.68	37.94	3.43	35.47	43.58	74.00	-30.42	147	83	peak
3	9808.000	37.73	39.74	3.96	35.74	45.69	74.00	-28.31	228	247	peak
4	12260.000	36.71	41.56	4.45	34.79	47.93	74.00	-26.07	221	106	peak
5	14712.000	28.96	43.16	4.78	34.31	42.59	74.00	-31.41	161	315	peak
6	17164.000	31.55	43.48	5.33	33.93	46.43	74.00	-27.57	229	237	peak
7	19616.000	29.57	32.1	5.72	34.69	32.70	74.00	-41.30	346	156	peak
8	22068.000	27.46	32.63	6.1	34.94	31.25	74.00	-42.75	321	120	peak
9	24520.000	27.77	33.31	6.5	35.88	31.70	74.00	-42.30	100	168	peak

*:Maximum data x:Over limit !:over margin

Note:

- According to the standards used, Where limits are specified by agencies for both average and peak (or quasi-peak) detection, if the peak (or quasi-peak) measured value complies with the average limit, it is unnecessary to perform an average measurement.
- “peak”: peak mode; “avg”: average mode
- The Spectrum noise level+Correction Factor < Limit - 6 dB
- Margin=Corrected Amplitude - Limit
- Corrected Amplitude=Radiated Amplitude+Antenna Correction Factor+Cable Loss-Pre-Amplifier Gain
- A margin of -8dB means that the emission is 8dB below the limit.

All frequencies from 1GHz to 25 GHz have been tested.

4.4 Band Edge Measurement

4.4.1 Test Procedure

Radiated

1. Antenna and Turntable test procedure same as Radiated Emission Measurement.
Equipment mode: Spectrum analyzer
Detector function: Peak mode
SPAN: 60MHz
RBW: 100KHz
VBW: 100KHz
Center frequency: 2.4GHz, 2.4835GHz.
2. Using Peak Search to read the peak power of Carrier frequencies after Maximum Hold function is completed
3. Find the next peak frequency outside the operation frequency band

4.4.2 Test Setup

Radiated

Same as *Radiated Emission Measurement*

4.4.3 802.11b Test Data:

Table: Band Edge measurement

Radiated Test

Temp. (° C): 25

Test Engr: Jerry

Humidity (%): 55

Channel	Frequency (MHz)	Spectrum Reading (dBuV)	Carrier - Outsideband Limit: >30dB (dB)	Pass/Fail
1	2412.48	66.3	---	---
Outside band	2400	27.4	38.9	Pass
11	2462.38	65.42	---	---
Outside band	2483.5	18.21	47.21	Pass

Band Edge Radiated Measurement

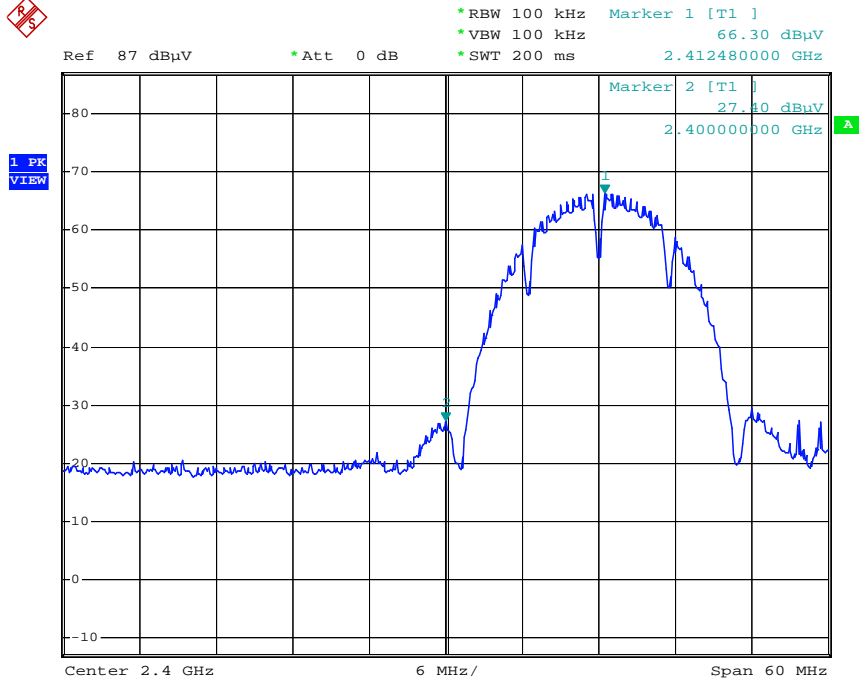

Date: 26.APR.2010 15:14:42

Band Edge Radiated Measurement

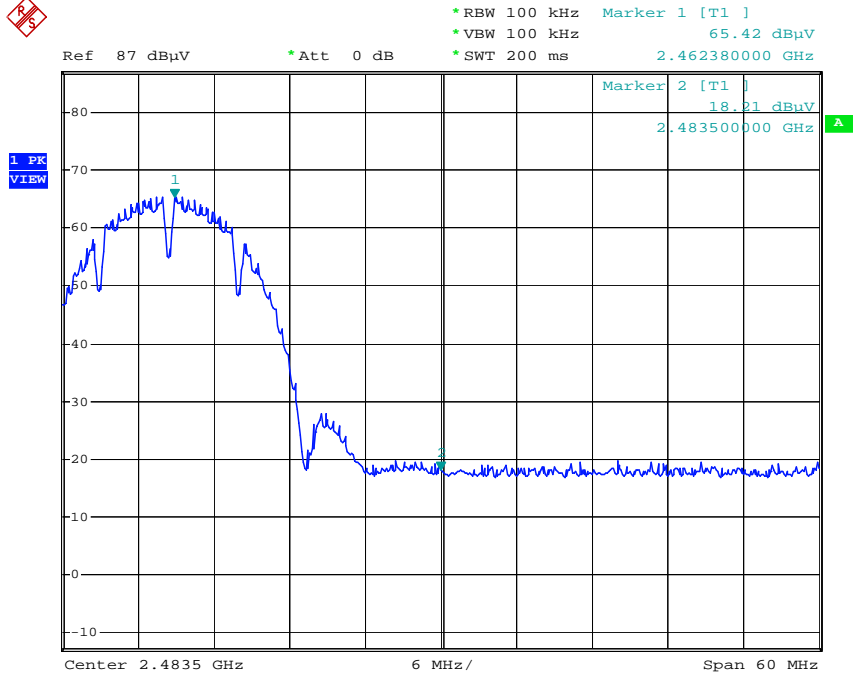

Date: 26.APR.2010 15:39:12

4.4.4 802.11g Test Data:

Table: Band Edge measurement

Radiated Test

Temp. (° C): 25

Test Engr: Jerry

Humidity (%): 55

Channel	Frequency (MHz)	Spectrum Reading (dBuV)	Carrier - Outsideband Limit: >30dB (dB)	Pass/Fail
1	2416.2	60.53	---	---
Outside band	2400	26.93	33.6	Pass
11	2459.86	58.17	---	---
Outside band	2483.5	18.99	39.18	Pass

Band Edge Radiated Measurement

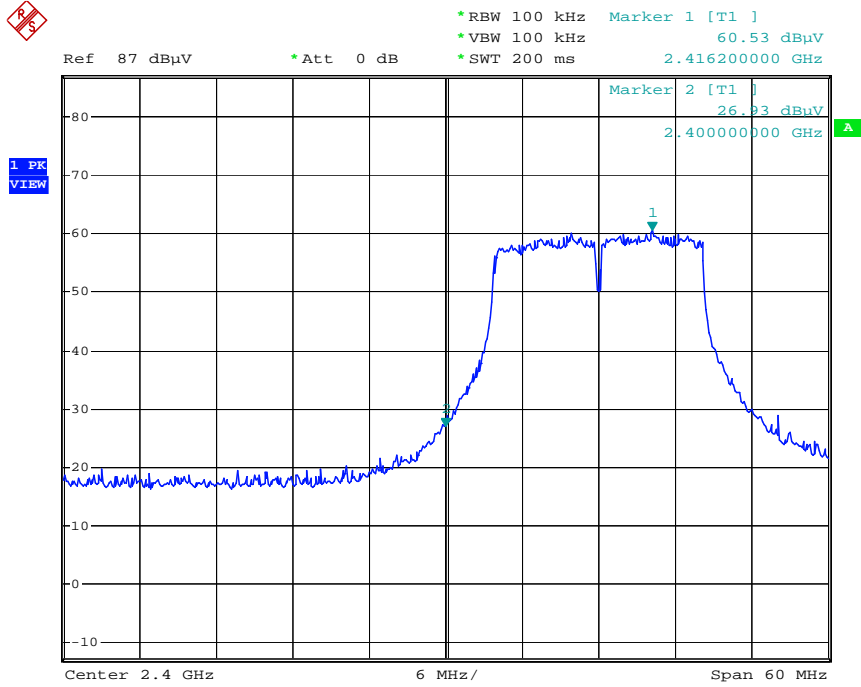

Date: 26.APR.2010 15:41:57

Band Edge Radiated Measurement

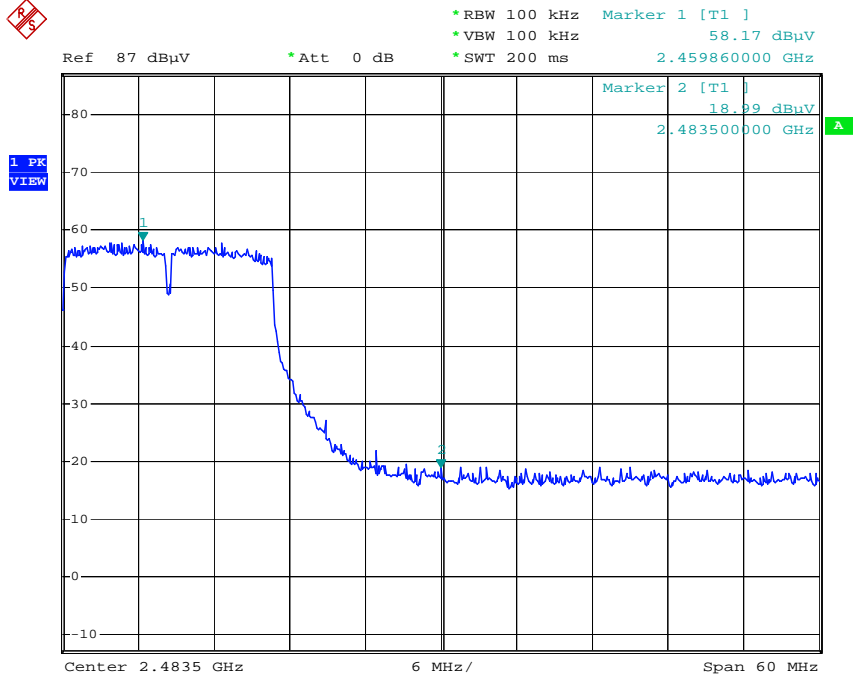

Date: 26.APR.2010 16:11:12

4.4.5 802.11n(HT20) Test Data:

Table: Band Edge measurement

Radiated Test

Temp. (° C): 25

Test Engr: Jerry

Humidity (%): 55

Channel	Frequency (MHz)	Spectrum Reading (dBuV)	Carrier - Outsideband Limit: >30dB (dB)	Pass/Fail
1	2409.12	59.57	---	---
Outside band	2400	27.88	31.69	Pass
11	2456.5	58.35	---	---
Outside band	2483.5	18.52	39.83	Pass

Band Edge Radiated Measurement

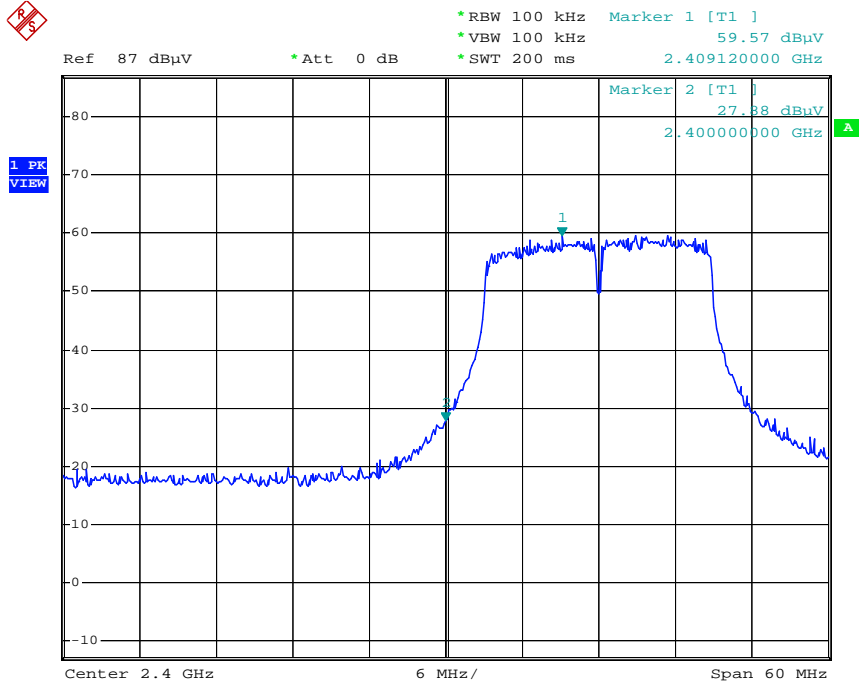

Date: 26.APR.2010 15:44:00

Band Edge Radiated Measurement

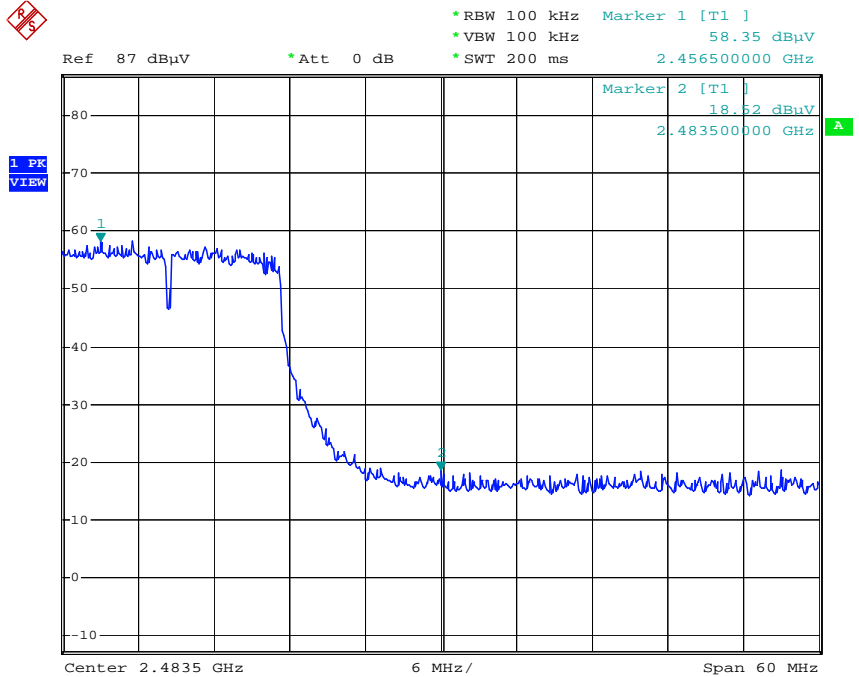

Date: 26.APR.2010 16:13:59

4.4.6 802.11n(HT40) Test Data:

Table: Band Edge measurement

Radiated Test

Temp. (° C): 25

Test Engr: Jerry

Humidity (%): 55

Channel	Frequency (MHz)	Spectrum Reading (dBuV)	Carrier - Outsideband Limit: >30dB (dB)	Pass/Fail
3	2425.6	57.85	---	---
Outside band	2398.6	26.87	30.98	Pass
9	2444.1	55.19	---	---
Outside band	2483.5	18.58	36.61	Pass

Band Edge Radiated Measurement

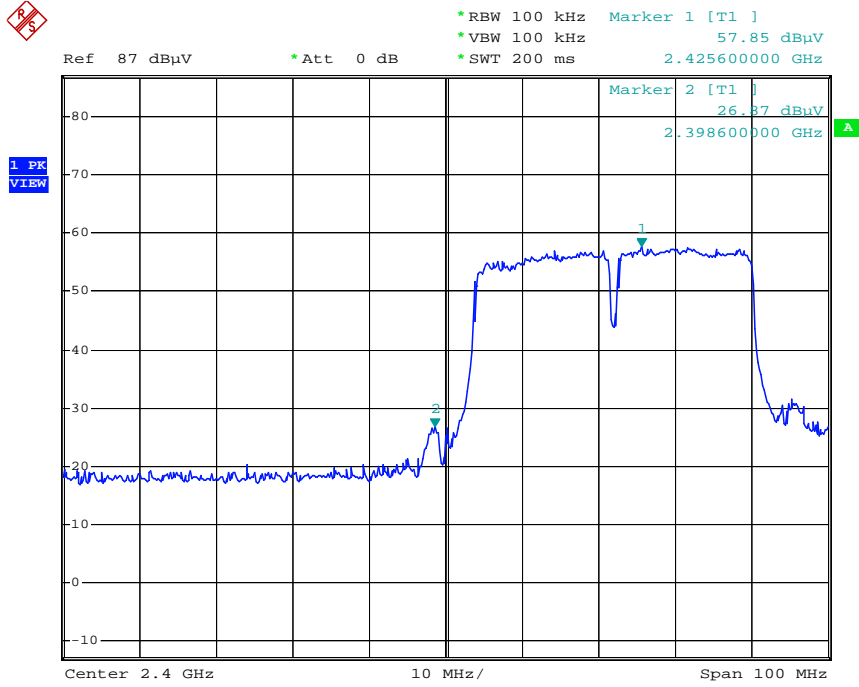

Date: 26.APR.2010 15:49:15

Band Edge Radiated Measurement

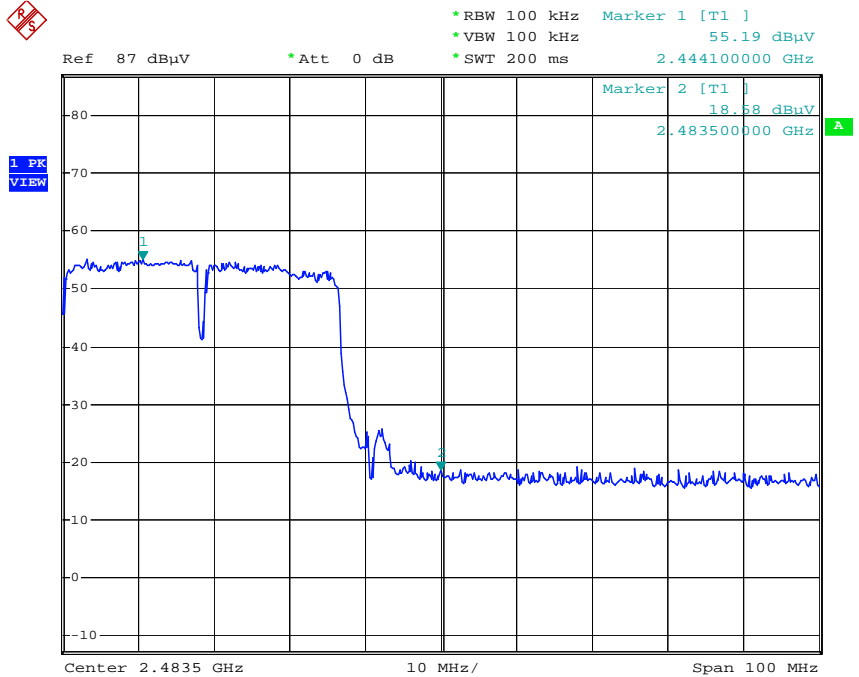

Date: 26.APR.2010 16:20:18

4.5 Band Edge Restricted Bands Measurement

4.5.1 Test Procedure (Radiated)

1. Antenna and Turntable test procedure same as Radiated Emission Measurement.
Equipment mode: Spectrum analyzer
Detector function: Peak mode
SPAN: 100MHz
RBW: 1MHz
VBW: 3MHz
Center frequency: 2.39GHz, 2.4835GHz.
2. Using Peak Search to read the peak power of Carrier frequencies after Maximum Hold function is completed.
3. Find the next peak frequency outside the operation frequency band
4. For peak frequency emission level measurement in Restricted Band
Change RBW: 1MHz
VBW: 10Hz
5. Get the spectrum reading after Maximum Hold function is completed.

4.5.2 Test Setup (Radiated)

Same as *Radiated Emission Measurement*

4.5.3 802.11b Test Data

Table Band Edge Measurement (Radiated)

Temp. (° C): 25

Test Engr: Jerry

Humidity (%): 55

Description	Frequency (MHz)	Spectrum Reading (dBuV)	Correction Factor (dB/m)	Emission Level (dBuV/m)	Limit (dBuV/m)	Equip. Setup VBW	Pass or Fail
Channel_1 (peak mode)	2413.2	72.44	36.85	109.29	---	3MHz	---
Channel_1 (average mode)	2412.8	67.69	36.85	104.54	---	10Hz	---
Channel_11 (peak mode)	2460.9	71.58	36.88	108.46	---	3MHz	---
Channel_11 (average mode)	2461.3	66.91	36.88	103.79	---	10Hz	---
Channel_1 Restricted band (peak mode)	2390	24.66	36.84	61.5	74	3MHz	Pass
Restricted band (average mode)	2390	11.89	36.84	48.73	54	10Hz	Pass
Channel_11 Restricted band (peak mode)	2483.5	24.71	36.91	61.62	74	3MHz	Pass
Restricted band (average mode)	2483.5	12.38	36.91	49.29	54	10Hz	Pass

Note:

- The spectrum plot of emission level measurement in restricted band is attached.
- Emission Level=Spectrum Reading+Correction Factor
- Correction Factor=Antenna Factor+cable loss–amplifier gain
- Both Horizontal and Vertical polarizaion have been tested and the worst data is listed above.

Band Edge measurement for radiated emission in Restricted Band (Radiated) Peak Mode (Lowest Channel)

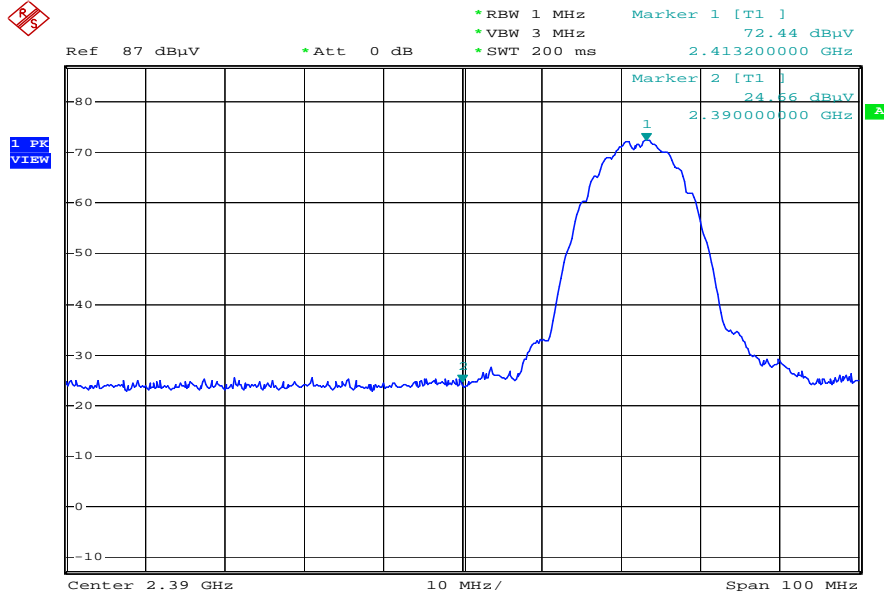

Date: 26.APR.2010 15:16:55

Band Edge measurement for radiated emission in Restricted Band (Radiated) Average Mode (Lowest Channel)

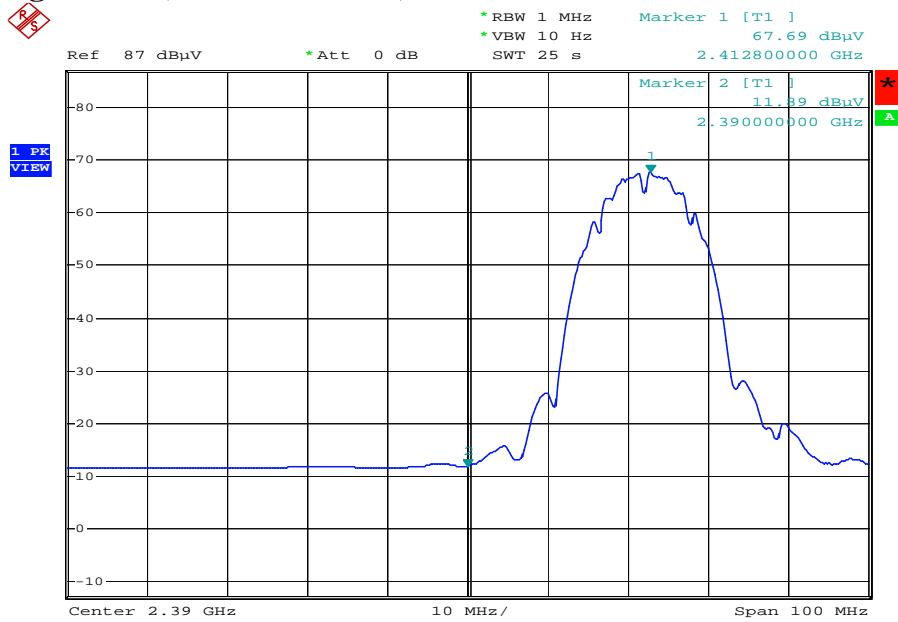

Date: 26.APR.2010 15:34:34

Band Edge measurement for radiated emission in Restricted Band (Radiated) Peak Mode (Highest Channel)

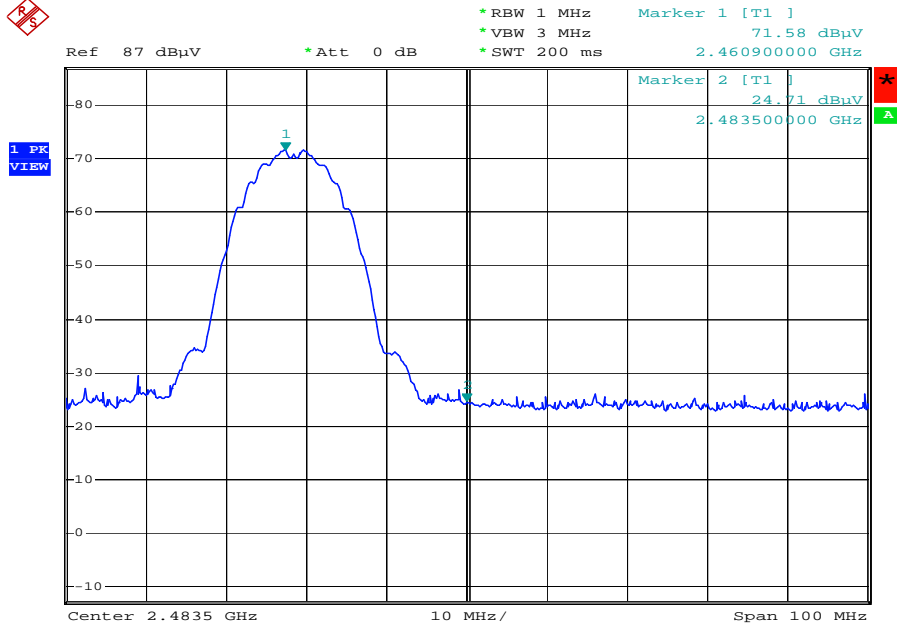

Date: 26.APR.2010 15:38:06

Band Edge measurement for radiated emission in Restricted Band (Radiated) Average Mode (Highest Channel)

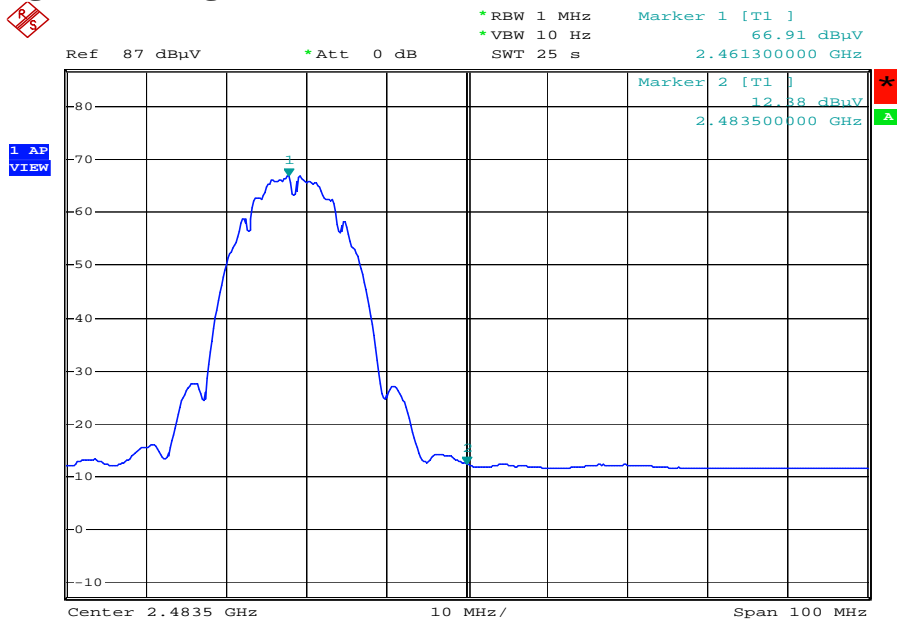

Date: 26.APR.2010 15:36:08

4.5.4 802.11g Test Data

Table Band Edge Measurement (Radiated)

Temp. (° C): 25

Test Engr: Jerry

Humidity (%): 55

Description	Frequency (MHz)	Spectrum Reading (dBUV)	Correction Factor (dB/m)	Emission Level (dBUV/m)	Limit (dBUV/m)	Equip. Setup VBW	Pass or Fail
Channel_1 (peak mode)	2416.6	71.54	36.85	108.39	---	3MHz	---
Channel_1 (average mode)	2418.2	61.14	36.85	97.99	---	10Hz	---
Channel_11 (peak mode)	2458.1	69.6	36.88	106.48	---	3MHz	---
Channel_11 (average mode)	2458.7	59.07	36.88	95.95	---	10Hz	---
Channel_1 Restricted band (peak mode)	2390	26.2	36.84	63.04	74	3MHz	Pass
Restricted band (average mode)	2390	12.62	36.84	49.46	54	10Hz	Pass
Channel_11 Restricted band (peak mode)	2483.5	25.52	36.91	62.43	74	3MHz	Pass
Restricted band (average mode)	2483.5	12.41	36.91	49.32	54	10Hz	Pass

Note:

- The Spectrum plot of emission level measurement in restricted band is attached.
- Emission Level=Spectrum Reading+Correction Factor
- Correction Factor=Antenna Factor+cable loss–amplifier gain
- Both Horizontal and Vertical polarizaion have been tested and the worst data is listed above.

Band Edge measurement for radiated emission in Restricted Band (Radiated) Peak Mode (Lowest Channel)

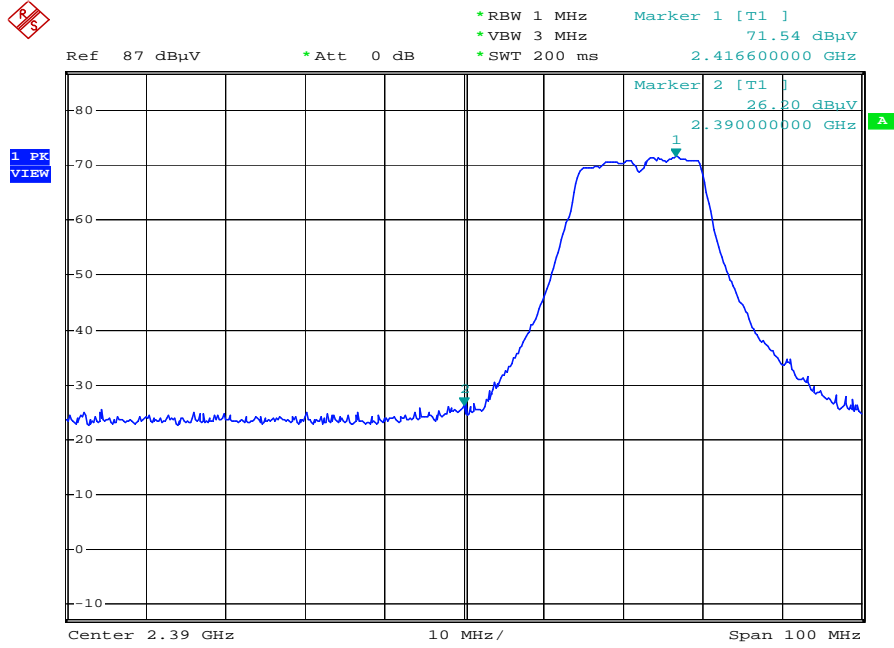

Date: 26.APR.2010 16:02:51

Band Edge measurement for radiated emission in Restricted Band (Radiated) Average Mode (Lowest Channel)

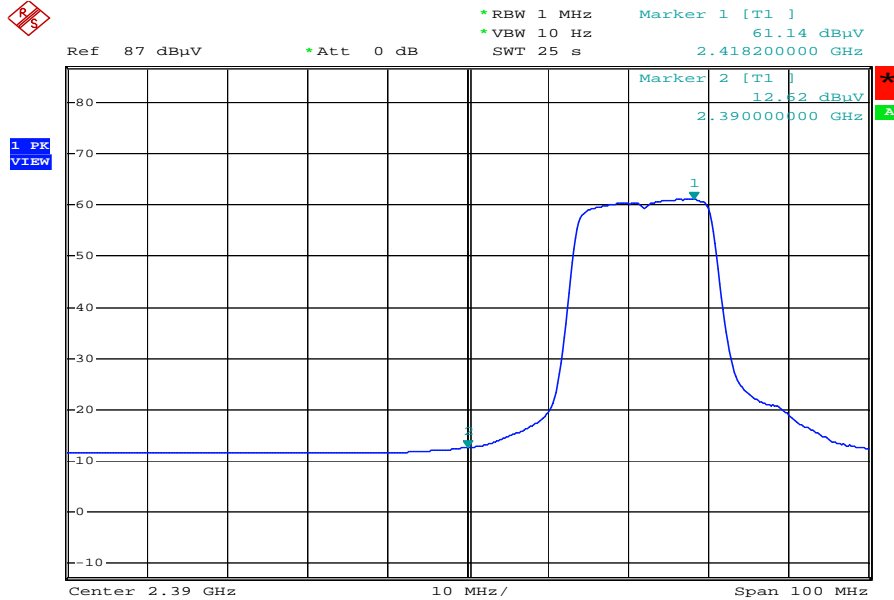

Date: 26.APR.2010 16:01:40

Band Edge measurement for radiated emission in Restricted Band (Radiated) Peak Mode (Highest Channel)

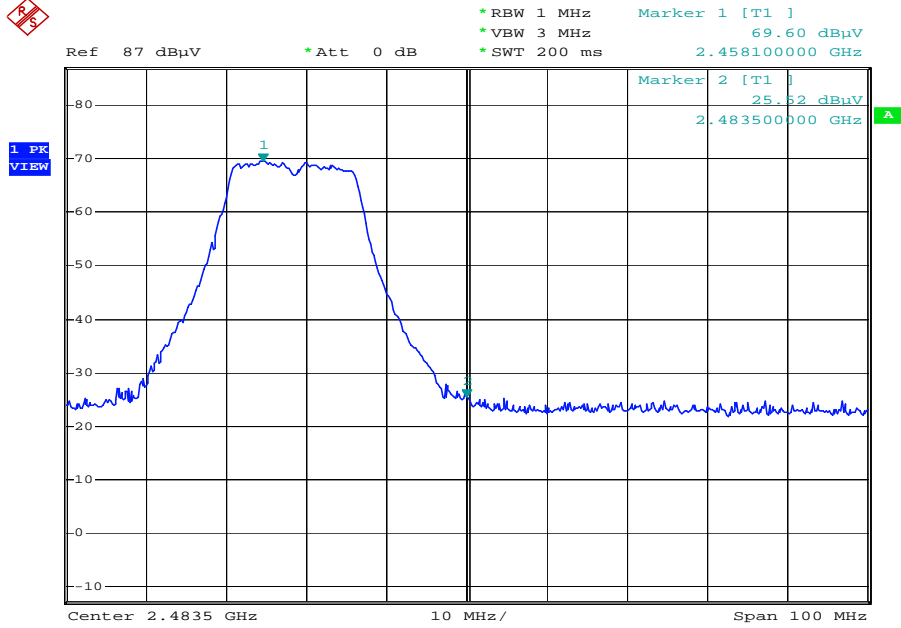

Date: 26.APR.2010 16:09:38

Band Edge measurement for radiated emission in Restricted Band (Radiated) Average Mode (Highest Channel)

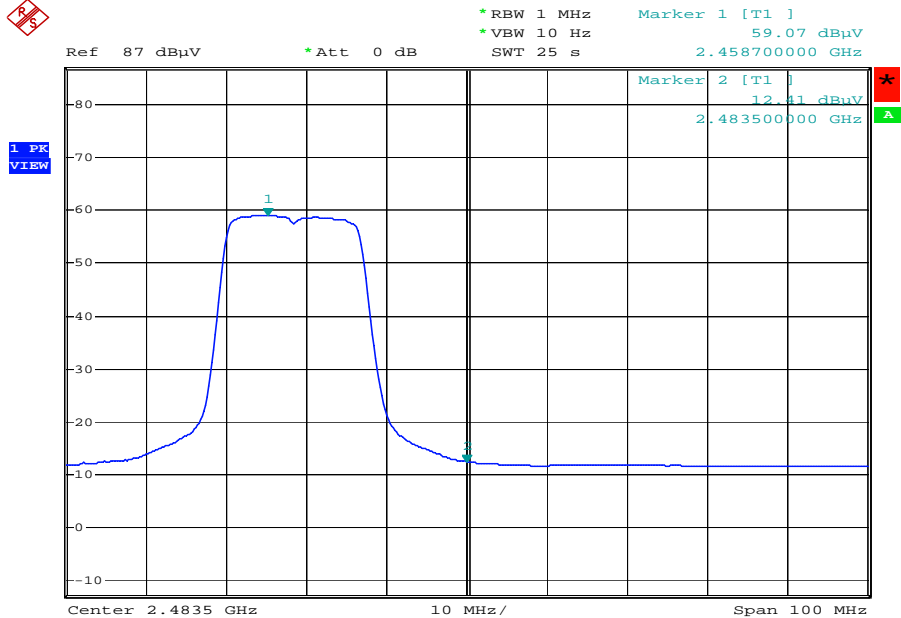

Date: 26.APR.2010 16:08:41

4.5.5 802.11n(HT20) Test Data

Table Band Edge Measurement (Radiated)

Temp. (° C): 25

Test Engr: Jerry

Humidity (%): 55

Description	Frequency (MHz)	Spectrum Reading (dBuV)	Correction Factor (dB/m)	Emission Level (dBuV/m)	Limit (dBuV/m)	Equip. Setup VBW	Pass or Fail
Channel_1 (peak mode)	2415.4	71.22	36.85	108.07	---	3MHz	---
Channel_1 (average mode)	2417.4	60.22	36.85	97.07	---	10Hz	---
Channel_11 (peak mode)	2458.7	70.06	36.88	106.94	---	3MHz	---
Channel_11 (average mode)	2458.7	58.58	36.88	95.46	---	10Hz	---
Channel_1 Restricted band (peak mode)	2390	25.4	36.84	62.24	74	3MHz	Pass
Restricted band (average mode)	2390	12.32	36.84	49.16	54	10Hz	Pass
Channel_11 Restricted band (peak mode)	2483.5	24.94	36.91	61.85	74	3MHz	Pass
Restricted band (average mode)	2483.5	12.32	36.91	49.23	54	10Hz	Pass

Note:

- The spectrum plot of emission level measurement in restricted band is attached.
- Emission Level=Spectrum Reading+Correction Factor
- Correction Factor=Antenna Factor+cable loss–amplifier gain
- Both Horizontal and Vertical polarizaion have been tested and the worst data is listed above.

Band Edge measurement for radiated emission in Restricted Band (Radiated) Peak Mode (Lowest Channel)

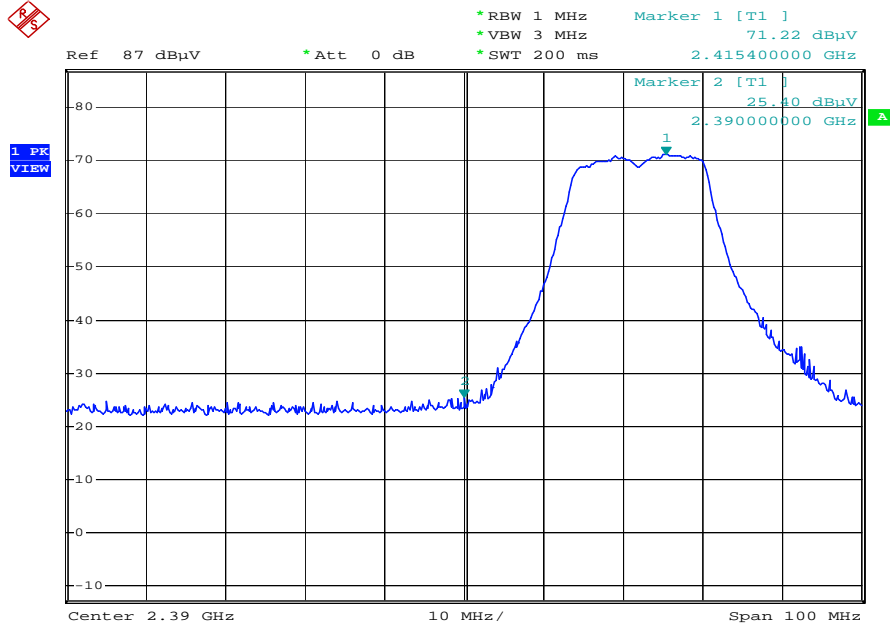

Date: 26.APR.2010 16:04:58

Band Edge measurement for radiated emission in Restricted Band (Radiated) Average Mode (Lowest Channel)

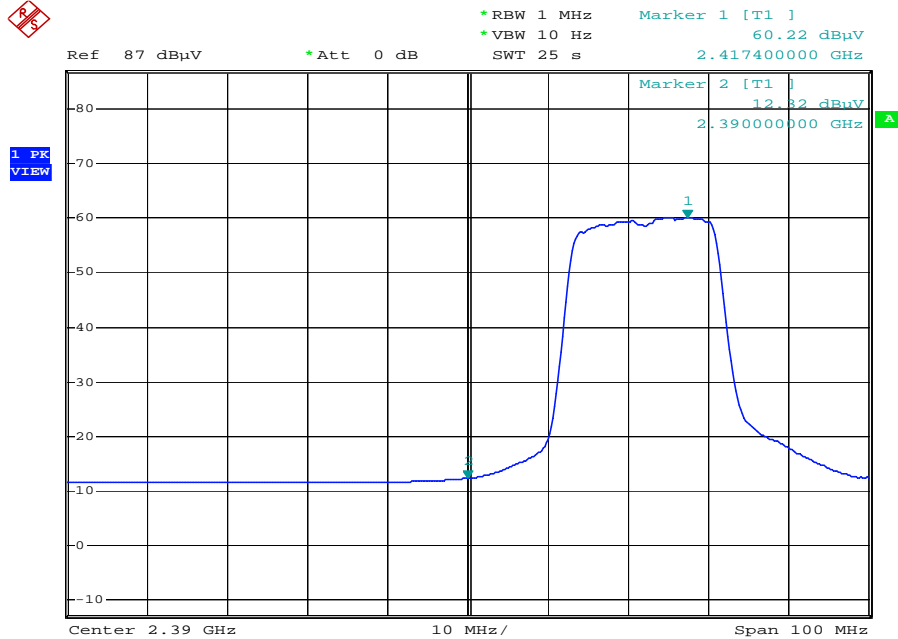

Date: 26.APR.2010 16:06:08

Band Edge measurement for radiated emission in Restricted Band (Radiated) Peak Mode (Highest Channel)

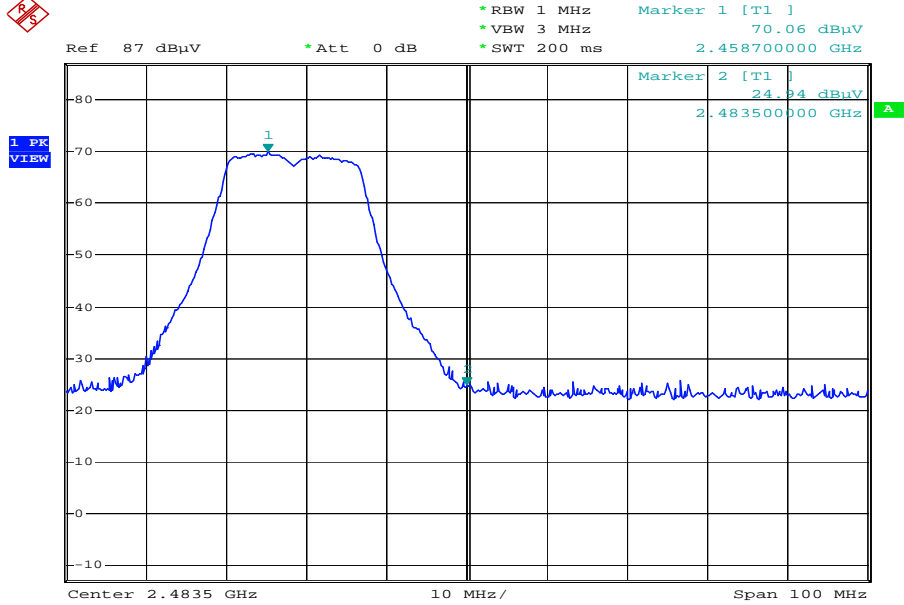

Date: 26.APR.2010 16:15:32

Band Edge measurement for radiated emission in Restricted Band (Radiated) Average Mode (Highest Channel)

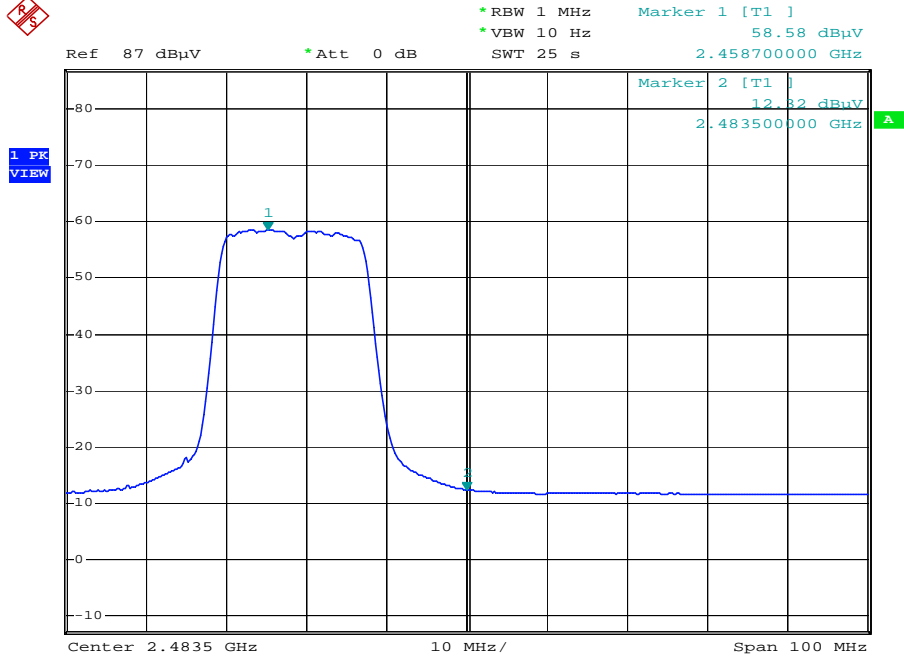

Date: 26.APR.2010 16:16:48

4.5.6 802.11n(HT40) Test Data

Table Band Edge Measurement (Radiated)

Temp. (° C): 25

Test Engr: Jerry

Humidity (%): 55

Description	Frequency (MHz)	Spectrum Reading (dBuV)	Correction Factor (dB/m)	Emission Level (dBuV/m)	Limit (dBuV/m)	Equip. Setup VBW	Pass or Fail
Channel_3 (peak mode)	2431.2	69.57	36.85	106.42	---	3MHz	---
Channel_1 (average mode)	2431.4	58.59	36.85	95.44	---	10Hz	---
Channel_9 (peak mode)	2448.3	67.13	36.88	104.01	---	3MHz	---
Channel_9 (average mode)	2443.3	56.42	36.88	93.3	---	10Hz	---
Channel_3 Restricted band (peak mode)	2390	28.28	36.84	65.12	74	3MHz	Pass
Restricted band (average mode)	2390	13.25	36.84	50.09	54	10Hz	Pass
Channel_9 Restricted band (peak mode)	2483.5	30.3	36.91	67.21	74	3MHz	Pass
Restricted band (average mode)	2483.5	13.51	36.91	50.42	54	10Hz	Pass

Note:

- The Spectrum plot of emission level measurement in restricted band is attached.
- Emission Level=Spectrum Reading+Correction Factor
- Correction Factor=Antenna Factor+cable loss–amplifier gain
- Both Horizontal and Vertical polarizaion have been tested and the worst data is listed above.

Band Edge measurement for radiated emission in Restricted Band (Radiated) Peak Mode (Lowest Channel)

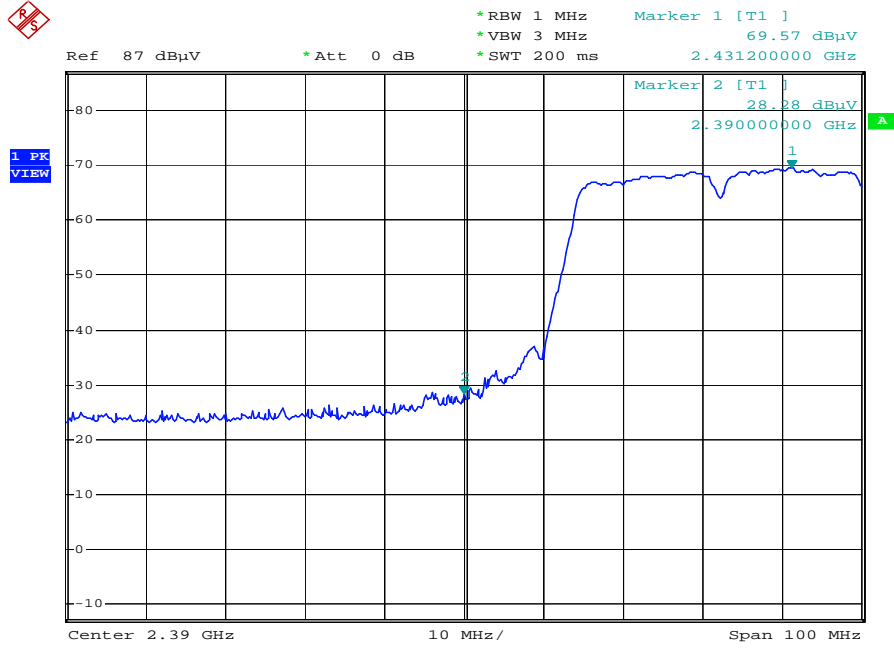

Date: 26.APR.2010 15:53:18

Band Edge measurement for radiated emission in Restricted Band (Radiated) Average Mode (Lowest Channel)

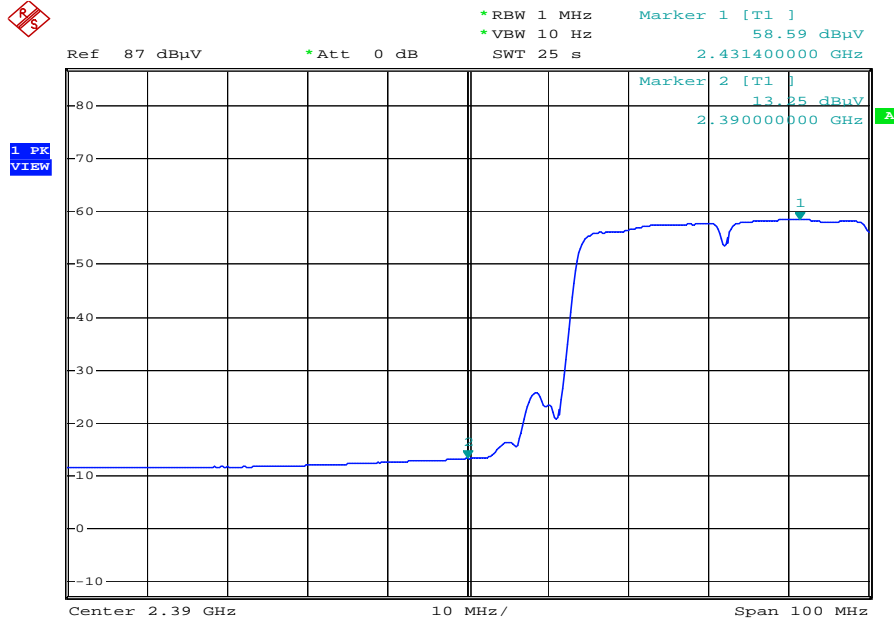

Date: 26.APR.2010 15:54:12

Band Edge measurement for radiated emission in Restricted Band (Radiated) Peak Mode (Highest Channel)

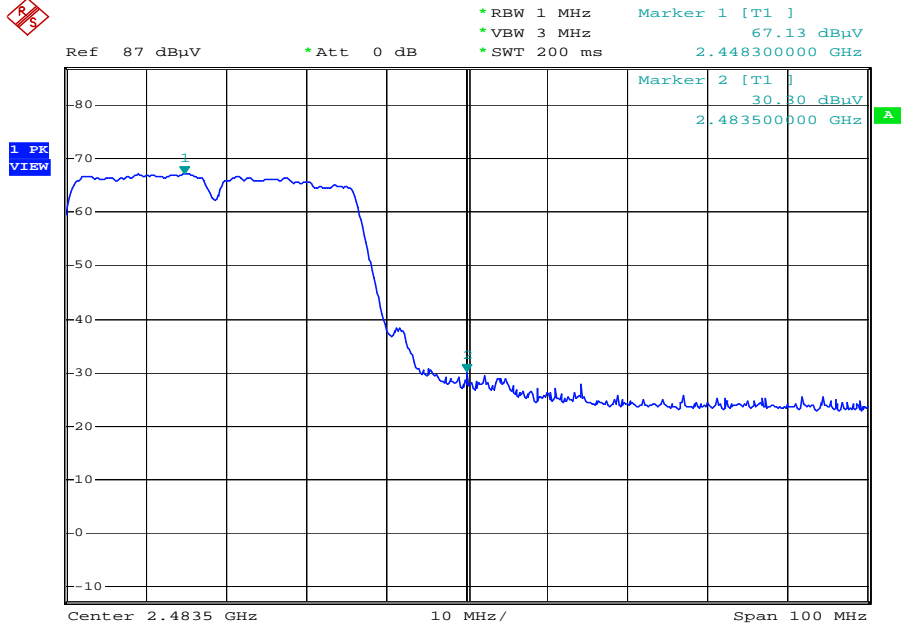

Date: 26.APR.2010 16:19:14

Band Edge measurement for radiated emission in Restricted Band (Radiated) Average Mode (Highest Channel)



Date: 26.APR.2010 16:18:26

4.6 RF Exposure Measurement [Section 15.247(b)(4) & 1.1307(b)]

See SAR report

5. Appendix

5.1 Appendix A: Measurement Procedure for Power line Conducted Emissions

The measurements are performed in a 3.5m x 3.4m x 2.5m shielded room, which referred as Conduction 01 test site, or a 3m x 3m x 2.3m test site, which referred as Conduction 02 test site. The EUT was placed on non-conduction 1.0m x 1.5m table, which is 0.8 meters above an earth-grounded.

Power to the EUT was provided through the LISN which has the Impedance (50ohm/50uH) vs. Frequency Characteristic in accordance with the required standard. Power to the LISNs were filtered to eliminate ambient signal interference and these filters were bonded to the ground plane. Peripheral equipment required to provide a functional system (support equipment) for EUT testing was powered from the second LISN through a ganged, metal power outlet box which is bonded to the ground plane at the LISN.

If the EUT is supplied with a flexible power cord, the power cord length in excess of the distance separating the EUT from the LISN shall be folded back and forth at the center of the lead so as to form a bundle not exceeding 40cm in length. If the EUT is provided with a permanently coiled power cord, bundling of the cord is not required. If the EUT is supplied without a power cord, the EUT shall be connected to the LISN by a power cord of the type specified by the manufacturer which shall not be longer than 1 meter. The excess power cord shall be bundled as described above. If a non-flexible power cord is provided with the EUT, it shall be cut to the length necessary to attach the EUT to the LISN and shall not be bundled.

The interconnecting cables were arranged and moved to get the maximum emission. Both the line of power cord, hot and neutral, were measured.

The highest emissions were analyzed in details by operating the spectrum analyzer in fixed tuned mode to determine the nature of the emissions and to provide information which could be useful in reducing their amplitude.

5.2 Appendix B: Test Procedure for Radiated Emissions

Preliminary Measurements in the Anechoic Chamber

The radiated emissions are initially measured in the anechoic chamber at a measurement distance of 3 meters. Desktop EUT are placed on a wooden stand 0.8 meter in height. The measurement antenna is 3 meters from the EUT. The test setup in anechoic chamber is the same as open site. The turntable rotated 360°. The antenna height is varied from 1-2.5m. The primary objective of the radiated measurements in the anechoic chamber is to identify the frequency spectrum in the absence of the electromagnetic environment existing on the open test site. The frequencies can then be pre-selected on the open test site to obtain the corresponding amplitude. The initial scan is made with the spectrum analyzer in automatic sweep mode. The spectrum peaks are then measured manually to determine the exact frequencies.

Measurements on the Open Site or 10m EMC Chamber

The radiated emissions test will then be repeated on the open site or 10m EMC chamber to measure the amplitudes accurately and without the multiple reflections existing in the shielded room. The EUT and support equipment are set up on the turntable of one of the 3 or 10 meter open field sites. Desktop EUT are set up on a wooden stand 0.8 meter above the ground.

For the initial measurements, the receiving antenna is varied from 1-4 meter height and is changed in the vertical plane from vertical to horizontal polarization at each frequency. Both reading are recorded with the quasi-peak detector with 120KHz bandwidth. For frequency between 30 MHz and 1000MHz, the reading is recorded with peak detector or quasi-peak detector. For frequency above 1 GHz, the reading is recorded with peak detector or average detector with 1 MHz bandwidth.

At the highest amplitudes observed, the EUT is rotated in the horizontal plane while changing the antenna polarization in the vertical plane to maximize the reading. The interconnecting cables were arranged and moved to get the maximum emission. Once the maximum reading is obtained, the antenna elevation and polarization will be varied between specified limits to maximize the readings.

5.3 Appendix C: Test Equipment

5.3.1 Test Equipment List

Location	Equipment Name	Brand	Model	S/N	Last Cal. Date	Next Cal. Date
Con02						
Conduction 02	Conduction 02 -1 Cable	WOKEN	CFD 300-NL	Conduction 02 -1	06/15/2009	06/15/2010
Conduction 02	EMI Receiver 14	ROHDE&SCHWARZ	ESCI	101034	03/02/2010	03/02/2011
Conduction 02	ISN T2 01	FCC	FCC-TLISN-T 2-02	20253	07/20/2009	07/20/2010
Conduction 02	ISN T4 03	FCC	FCC-TLISN-T 4-02	20254	07/20/2009	07/20/2010
Conduction 02	ISN T8 01	FCC	FCC-TLINS-T 8-02	20255	07/20/2009	07/20/2010
Conduction 02	LISN 01	R&S	ESH2-Z5	890485/013	01/07/2010	01/07/2011
Conduction 02	LISN 04	EMCO	3810/2	9604-1429	05/13/2009	05/13/2010

Location	Equipment Name	Brand	Model	S/N	Last Cal. Date	Next Cal. Date
Chmb14						
Radiation (Chamber14)	BILOG Antenna 14	Schaffner	CBL6112D	22612	03/19/2010	03/19/2011
Radiation (Chamber14)	Coaxial Cable Chmb 14-3M	NOKIA KABEL	M17/74-RG21 3	Chmb 14-3M	07/08/2009	07/08/2010
Radiation (Chamber14)	EMI Receiver 06	Schwarzbeck Mess-Elektronik	FCVU 1534	1534-149	07/02/2009	07/02/2010
Radiation (Chamber14)	Spectrum Analyzer 21	Agilent	N9010A	MY49060537	07/03/2009	07/03/2010
Rad. Above 1GHz (Chamber14)	SUCOFLEX 1GHz~18GHz cable	HUBER+SUHN ER AG.	Sucoflex 106 & 104	60404/6 & 286303/4	07/06/2009	07/06/2010
Rad. Above 1GHz (Chamber14)	SUCOFLEX 1GHz~40GHz cable	HUBER+SUHN ER AG.	Sucoflex 102	27963/2	09/16/2009	09/16/2010

Note: Calibration is traceable to NIST or national or international standards.

5.3.2 Software for Controlling Spectrum/Receiver and Calculating Test Data

Radiation/Conduction	Filename	Version	Issued Date
Lung_Tan Conduction	EZ EMC	1.1.4.2	2/10/2007
Lung_Tan Radiation	EZ EMC	1.1.4.2	1/24/2007

5.4 Appendix D: Layout of EUT and Support Equipment

5.4.1 General Conducted Test Configuration

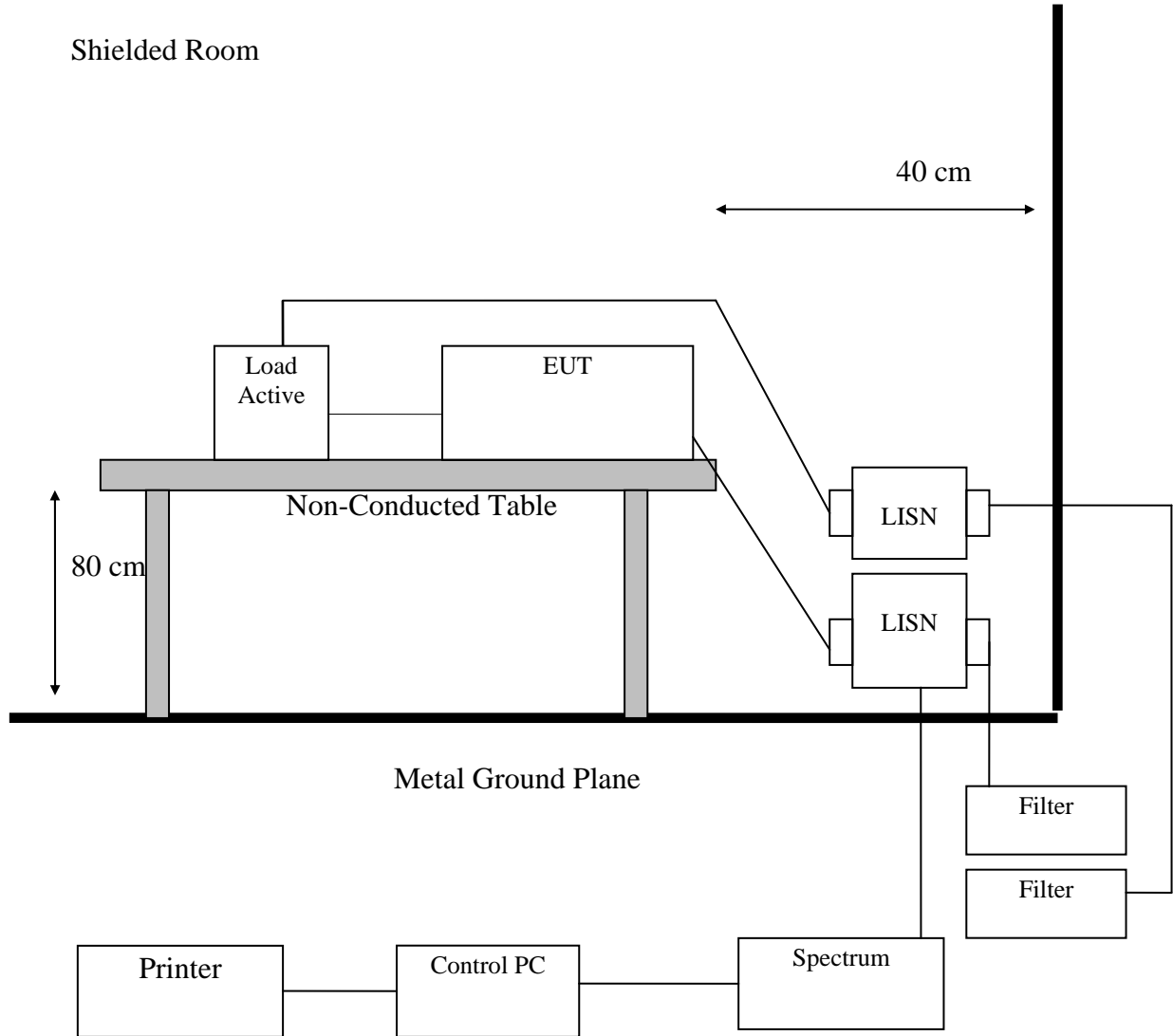

5.4.2 General Radiation Test Configuration

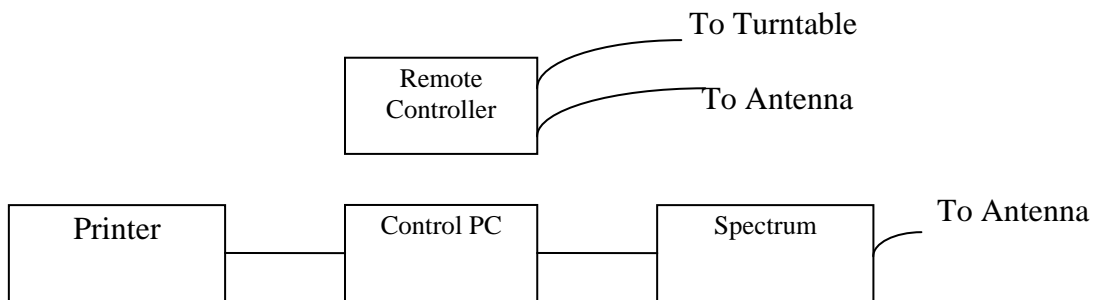
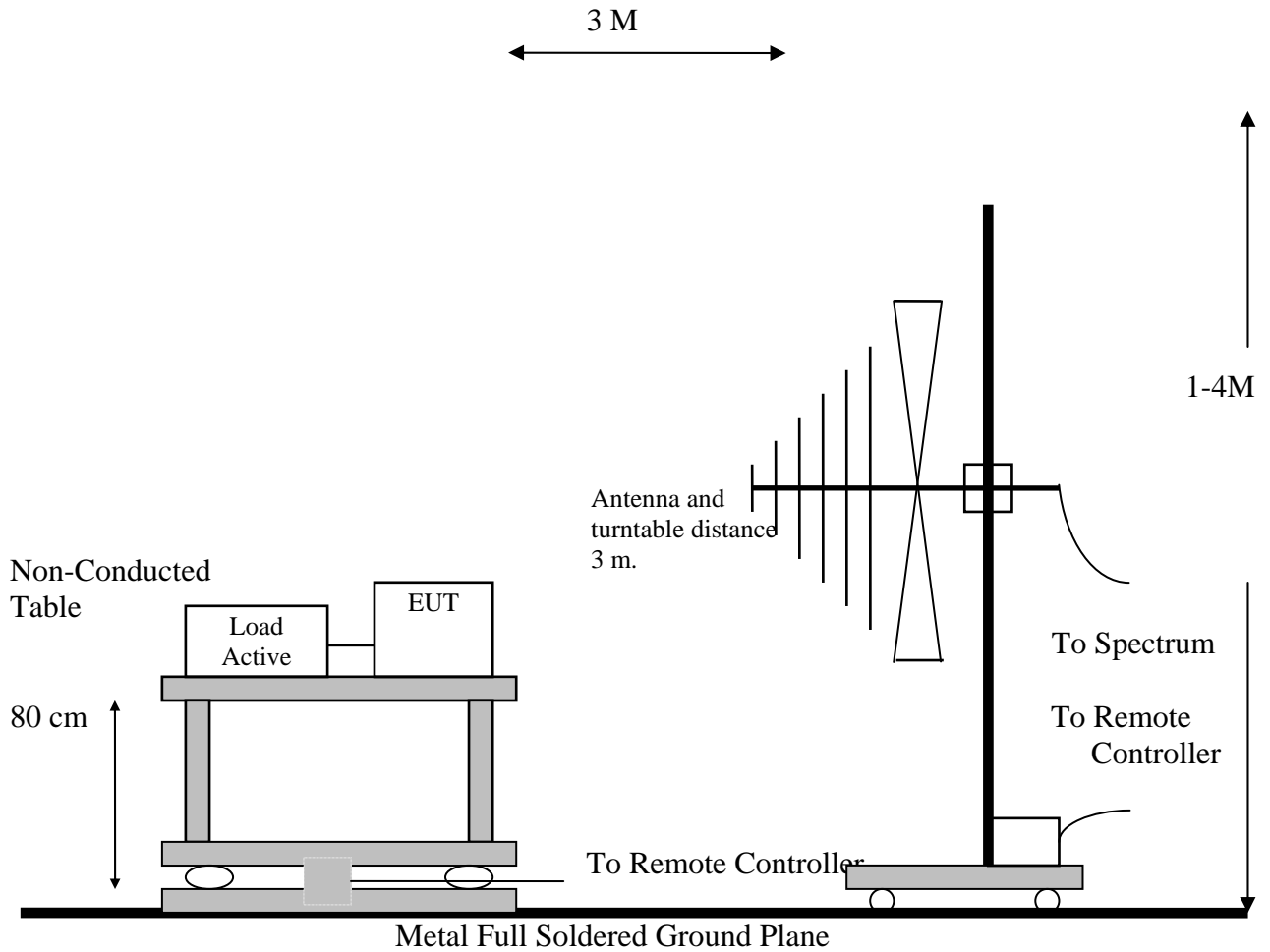

5.5 Appendix E: Accuracy of Measurement

The measurement uncertainty refers to CISPR 16-4-2:2003. The coverage factor $k = 2$ yields approximately a 95 % level of confidence.

<Conduction 02>: ± 3.263 dB

<Chamber 14 (3M)>

Horizontal

30MHz~200MHz: ± 4.316 dB

200MHz~1GHz: ± 4.587 dB

Vertically

30MHz~200MHz: ± 4.420 dB

200MHz~1GHz: ± 4.573 dB

1GHz~26.5GHz ± 3.722 dB

5.6 Appendix F: Photographs of EUT Configuration Test Set Up

The Front View of Highest Conducted Set-up For EUT



The Back View of Highest Conducted Set-up For EUT



The Front View of Highest Radiated Set-up For EUT

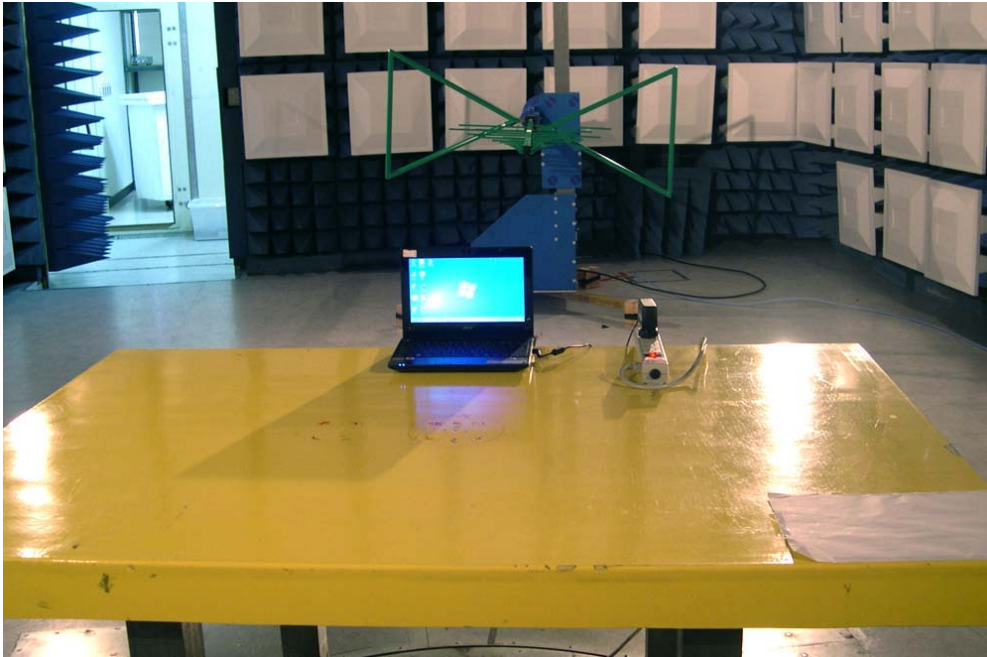

The Back View of Highest Radiated Set-up For EUT

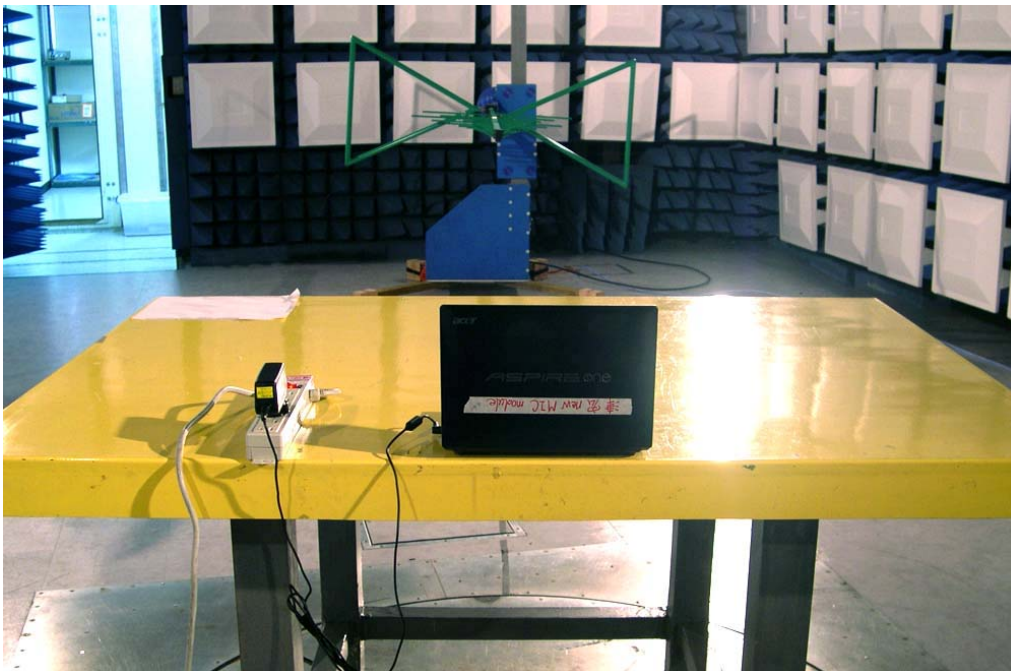

5.7 Appendix G: Antenna Spec.

Please refer to the attached file.