

FCC 47 CFR PART 15 SUBPART C

Product Type : WLAN module
Applicant : Acer Incorporated
Address : 8F, 88, Sec.1, Hsin Tai Wu Rd. Hsichih, Taipei Hsien 221
Taiwan, R.O.C.
Trade Name : acer
Model Number : AR5B97
Test Specification : FCC 47 CFR PART 15 SUBPART C: Oct., 2010
Canada RSS-210 ISSUE 8: Dec., 2010
Canada RSS-Gen ISSUE 3: Dec., 2010
ANSI C63.4-2003
Application Purpose : Class II Permissive Change
Issue Date : Apr. 01, 2011

Issue by

A Test Lab Techno Corp.
No. 140-1, Changan Street, Bade City,
Taoyuan Country 334, Taiwan R.O.C.
Tel : +86-3-2710188 / Fax : +86-3-2710190



Taiwan Accreditation Foundation accreditation number: 1330

Note: This report shall not be reproduced except in full, without the written approval of A Test Lab Techno Corp. This document may be altered or revised by A Test Lab Techno Corp. personnel only, and shall be noted in the revision section of the document. The client should not use it to claim product endorsement by TAF, or any government agencies. The test results in the report only apply to the tested sample.

Revision History

Rev.	Issue Date	Revisions	Revised By
00	Apr. 01, 2011	Initial Issue	

Verification

Issued Date: 2011/04/01

Product Type : WLAN module
Applicant : Acer Incorporated
Address : 8F, 88, Sec.1, Hsin Tai Wu Rd. Hsichih, Taipei Hsien 221
Taiwan, R.O.C.
Trade Name : acer
Model Number : AR5B97
FCC ID : HLZ-AR5B97
EUT Rated Voltage : DC 19V, 2.15A
Test Voltage : 120 Vac / 60 Hz
Applicable : FCC 47 CFR PART 15 SUBPART C: Oct., 2010
Standard : Canada RSS-210 ISSUE 8: Dec., 2010
Canada RSS-Gen ISSUE 3: Dec., 2010
ANSI C63.4-2003
Application Purpose : Class II Permissive Change
Test Result : Complied
Performed Lab. : A Test Lab Techno Corp.

No. 140-1, Changan Street, Bade City,
Taoyuan Country 334, Taiwan R.O.C.

Tel : +86-3-2710188 / Fax : +86-3-2710190

Taiwan Accreditation Foundation accreditation number:
1330



<http://www.atl-lab.com.tw/e-index.htm>

The above equipment has been tested by A Test Lab Techno Corp., and found compliance with the requirements set forth in the Electromagnetic Compatibility Directive 2004/108/EC and technical standards mentioned above. The results of testing in this report apply only to the product/system, which was tested. Other similar equipment will not necessarily produce the same results due to production tolerance and measurement uncertainties.

Approved By : 
(Manager) (Miller Lee)

Reviewed By : 
(Testing Engineer) (Gary Wu)

TABLE OF CONTENTS

1 General Information.....	5
2 EUT Description.....	6
3 Test Methodology.....	7
3.1. Mode of Operation	7
3.2. EUT Exercise Software.....	7
3.3. Configuration of Test System Details	7
3.4. Test Site Environment.....	8
4 Maximum Conducted Output Power Measurement	9
4.1. Limit	9
4.2. Test Setup	9
4.3. Test Instruments.....	9
4.4. Test Procedure.....	9
4.5. Test Result	10
5 Transmitter Radiated Emissions Measurement	11
5.1. Limit	11
5.2. Test Instruments.....	11
5.3. Setup.....	12
5.4. Test Procedure.....	12
5.5. Test Result	14
6 Band Edges Measurement.....	23
6.1. Limit	23
6.2. Test Setup	23
6.3. Test Instruments.....	23
6.4. Test Procedure.....	24
6.5. Test Result	25
7 Antenna Requirements	41
7.1. Limit	41
7.2. Antenna Connector Construction.....	41

1 General Information

1.1 Summary of Test Result

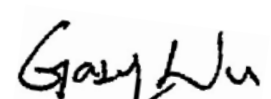
Standard		Item	Result	Remark
15.247	RSS-210			
15.247(b)(3)	A8.4	Max. Output Power	PASS	-----
15.247(d)	A8.5	Transmitter Radiated Emissions	PASS	-----
15.247(d)	A8.5	Band Edge Measurement	PASS	-----
15.203	-	Antenna Requirement	PASS	-----

The test results of this report relate only to the tested sample(s) identified in this report. Manufacturer or whom it may concern should recognize the pass or fail of the test result.

1.2 Measurement Uncertainty

Conducted Emission

The measurement uncertainty is evaluated as ± 2.24 dB.

Radiated Emission

The measurement uncertainty of 30 MHz - 1GHz is evaluated as ± 3.072 dB.

2 EUT Description

Product	:	WLAN module
Trade Name	:	acer
Model Number	:	AR5B97
Applicant	:	Acer Incorporated 8F, 88, Sec.1, Hsin Tai Wu Rd. Hsichih, Taipei Hsien 221 Taiwan, R.O.C.
FCC ID	:	HLZ-AR5B97
Frequency Range	:	IEEE 802.11b / IEEE 802.11g: 2412MHz~2462MHz draft 802.11n Standard-20MHz: 2412MHz~2462MHz draft 802.11n Wide-40MHz: 2422MHz~2452MHz
Modulation Type	:	IEEE 802.11b:DSSS(CCK, DQPSK, DBPSK) IEEE 802.11g:DSSS(CCK, DQPSK, DBPSK)+ OFDM(QPSK, BPSK, 16-QAM, 64-QAM) draft 802.11n Standard-20MHz channel mode: OFDM(6.5,7.2, 13,14.4, 14.44, 19.5,217,26,28.89,28.9,39.43.3,43.33,52,57.78, 57.8, 58.5, 65.0, 72.2, 78, 86.67,104,115.56,117,130 and 144.44 Mbps) draft 802.11n Wide-40MHz channel mode: OFDM(13.5,15,27,30,40.5, 45,54,60,81,90,108,120, 121.5,135,150,162,180,216,240,243,270 and 300 Mbps)
Antenna Type	:	PIFA Type
Antenna Gain	:	With Cable loss: Main: -2.85 dBi, Aux: -1.07dBi Without Cable loss: Main: -1.45 dBi, Aux: 0.24dBi
Max. RF Output Power	:	IEEE 802.11b: 0.167 W / 22.23 dBm IEEE 802.11g: 0.501 W / 27.00 dBm draft 802.11n Standard-20MHz: 0.498 W / 26.97 dBm draft 802.11n Wide-40MHz: 0.499 W / 26.98 dBm
Host Used	:	acer, P1VE6
Component		
Power Adapter	:	LEI, IU40-11190-011S Input: 100-240 Vac, 50-60 Hz, 1 A Output: 19Vdc, 2.15A Cable out: Non-Shielded, 2.5 m with one core
Battery	:	acer, AL10A31 11.1 Vdc, 2200mAh

3 Test Methodology

3.1. Mode of Operation

Decision of Test ATL has verified the construction and function in typical operation. All the test modes were carried out with the EUT in normal operation, which was shown in this test report and defined as:

Test Mode
Mode 1: Normal Operation Mode
Mode 2: IEEE 802.11b Link Mode
Mode 3: IEEE 802.11g Link Mode
Mode 4: draft 802.11n Standard-20MHz Link Mode
Mode 5: draft 802.11n Wide-40MHz Link Mode
Mode 6: Receiver Mode

3.2. EUT Exercise Software

1.	Turn on the power of all equipment.
2.	EUT run ART test program.

3.3. Configuration of Test System Details

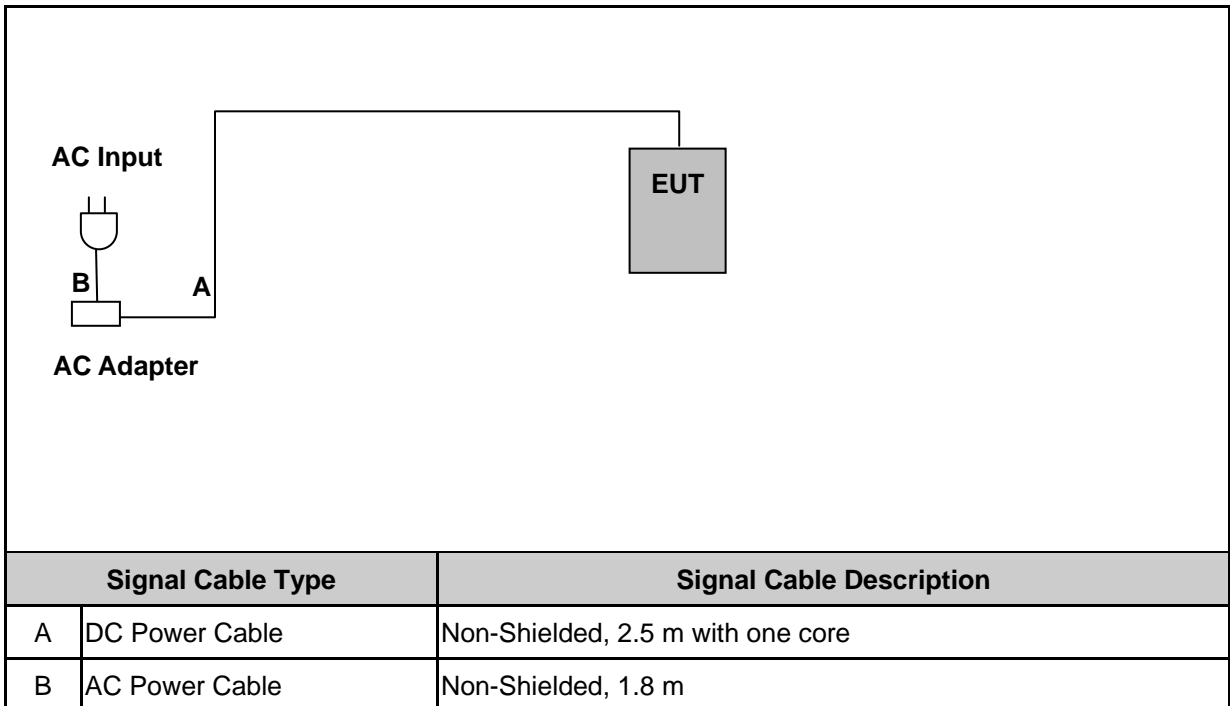

3.4. Test Site Environment

Items	Required (IEC 68-1)	Actual
Temperature (°C)	15-35	26
Humidity (%RH)	25-75	60
Barometric pressure (mbar)	860-1060	950-1000

4 Maximum Conducted Output Power Measurement

4.1. Limit

For systems using digital modulation in the 2400-2483.5MHz, the limit for peak output power is 30dBm.

4.2. Test Setup

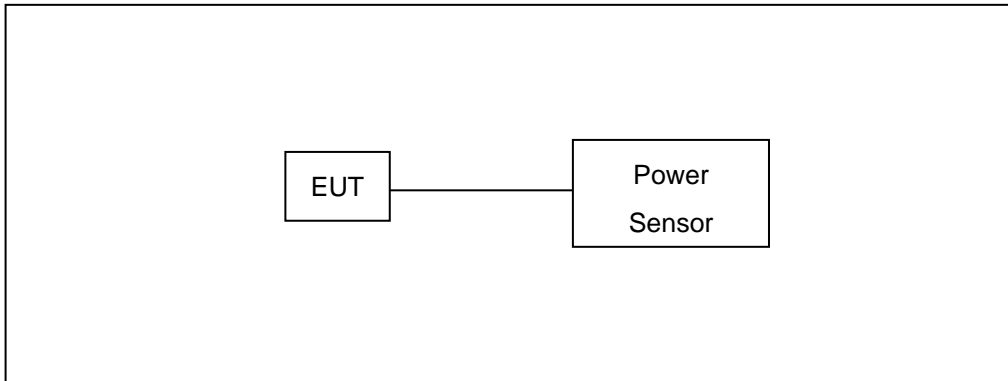

4.3. Test Instruments

Equipment	Manufacturer	Model Number	Serial Number	Cal. Date	Remark
Power Sensor	R&S	NRP-Z81	100017	05/17/2009	(2)
Test Site	ATL	TE06	TE06	N.C.R.	-----

Remark: ⁽¹⁾ Calibration period 1 year. ⁽²⁾ Calibration period 2 years.

NOTE: N.C.R. = No Calibration Request.

4.4. Test Procedure

The tests below are run with the EUT's transmitter set at high power in TX mode. The EUT is needed to force selection of output power level and channel number. While testing, EUT was set to transmit continuously. Remove the Subjective device's antenna and connect the RF output port to power sensor.

The maximum peak output power shall not exceed 1 watt.

Use a direct connection between the antenna port of transmitter and the power sensor, for prevent the power sensor input attenuation 40-50 dB. Set the RBW Bandwidth of the emission or use a channel power meter mode.

For antennas with gains of 6 dBi or less, maximum allowed transmitter output is 1 watt (+30 dBm). For antennas with gains greater than 6 dBi, transmitter output level must be decreased by an amount equal to $(\text{GAIN} - 6)/3$ dBm.

The antenna port of the EUT was connected to the input of a power sensor. Power was read directly and cable loss correction was added to the reading to obtain power at the EUT antenna terminals.

4.5. Test Result

Product	WLAN module													
Test Item	Maximum Conducted Output Power													
Test Mode	Mode 2: IEEE 802.11b Link Mode													
Date of Test	03/30/2011							Test Site			TE06			
Frequency (MHz)	Data Rate	Average						Peak						Limit (dBm)
		Chain 0		Chain 1		Total		Chain 0		Chain 1		Total		
		dBm	W	dBm	W	dBm	W	dBm	W	dBm	W	dBm	W	
2412	1	16.45	0.044	16.87	0.049	19.68	0.093	19.18	0.083	18.87	0.077	22.04	0.160	< 30
2437	1	16.75	0.047	17.10	0.051	19.94	0.099	19.14	0.082	19.29	0.085	22.23	0.167	< 30
2462	1	15.87	0.039	16.25	0.042	19.07	0.081	18.30	0.068	18.37	0.069	21.35	0.136	< 30

Product	WLAN module													
Test Item	Maximum Conducted Output Power													
Test Mode	Mode 3: IEEE 802.11g Link Mode													
Date of Test	03/30/2011							Test Site			TE06			
Frequency (MHz)	Data Rate	Average						Peak						Limit (dBm)
		Chain 0		Chain 1		Total		Chain 0		Chain 1		Total		
		dBm	W	dBm	W	dBm	W	dBm	W	dBm	W	dBm	W	
2412	6	13.99	0.025	14.95	0.031	17.51	0.056	22.76	0.189	22.86	0.193	25.82	0.382	< 30
2437	6	17.18	0.052	17.58	0.057	20.39	0.109	23.91	0.246	24.06	0.255	27.00	0.501	< 30
2462	6	12.21	0.017	11.84	0.015	15.04	0.032	21.57	0.144	20.62	0.115	24.13	0.259	< 30

Product	WLAN module													
Test Item	Maximum Conducted Output Power													
Test Mode	Mode 4: draft 802.11n Standard-20MHz Link Mode													
Date of Test	03/30/2011							Test Site			TE06			
Frequency (MHz)	Data Rate	Average						Peak						Limit (dBm)
		Chain 0		Chain 1		Total		Chain 0		Chain 1		Total		
		dBm	W	dBm	W	dBm	W	dBm	W	dBm	W	dBm	W	
2412	6.5	13.86	0.024	14.19	0.026	17.04	0.051	22.49	0.177	22.36	0.172	25.44	0.350	< 30
2437	6.5	17.11	0.051	17.55	0.057	20.35	0.108	23.50	0.224	24.38	0.274	26.97	0.498	< 30
2462	6.5	10.90	0.012	11.72	0.015	14.34	0.027	20.46	0.111	21.31	0.135	23.92	0.246	< 30

Product	WLAN module													
Test Item	Maximum Conducted Output Power													
Test Mode	Mode 5: draft 802.11n Wide-40MHz Link Mode													
Date of Test	03/30/2011							Test Site			TE06			
Frequency (MHz)	Data Rate	Average						Peak						Limit (dBm)
		Chain 0		Chain 1		Total		Chain 0		Chain 1		Total		
		dBm	W	dBm	W	dBm	W	dBm	W	dBm	W	dBm	W	
2422	13.5	12.40	0.017	12.36	0.017	15.39	0.035	22.44	0.175	22.83	0.192	25.65	0.367	< 30
2437	13.5	14.70	0.030	15.11	0.032	17.92	0.062	23.61	0.230	24.30	0.269	26.98	0.499	< 30
2452	13.5	9.96	0.010	9.83	0.010	12.91	0.020	21.15	0.130	21.03	0.127	24.10	0.257	< 30

5 Transmitter Radiated Emissions Measurement

5.1. Limit

Frequency Range (MHz)	Peak (dBuV/m)
30 to 88	40
88 to 216	43.5
216 to 960	46
Above 960	54

5.2. Test Instruments

3 Meter Chamber					
Equipment	Manufacturer	Model Number	Serial Number	Cal. Date	Remark
RF Pre-selector	Agilent	N9039A	MY46520256	01/18/2011	(2)
Spectrum Analyzer	Agilent	E4446A	MY46180578	01/18/2011	(2)
Pre Amplifier	Agilent	8449B	3008A02237	02/23/2011	(1)
Pre Amplifier	Agilent	8447D	2944A10961	02/23/2011	(1)
Broadband Antenna (30MHz~1GHz)	SCHWARZBECK MESS-ELEKTRONIK	VULB9163	9163-270	06/23/2009	(2)
Horn Antenna (1~18GHz)	SCHWARZBECK MESS-ELEKTRONIK	BBHA9120D	9120D-550	07/01/2009	(2)
Horn Antenna (18~40GHz)	SCHWARZBECK MESS-ELEKTRONIK	BBHA9170	9170-320	06/30/2009	(2)
Test Site	ATL	TE01	TE01	N.C.R.	-----

Remark: ⁽¹⁾ Calibration period 1 year. ⁽²⁾ Calibration period 2 years.

NOTE: N.C.R. = No Calibration Request.

5.3. Setup

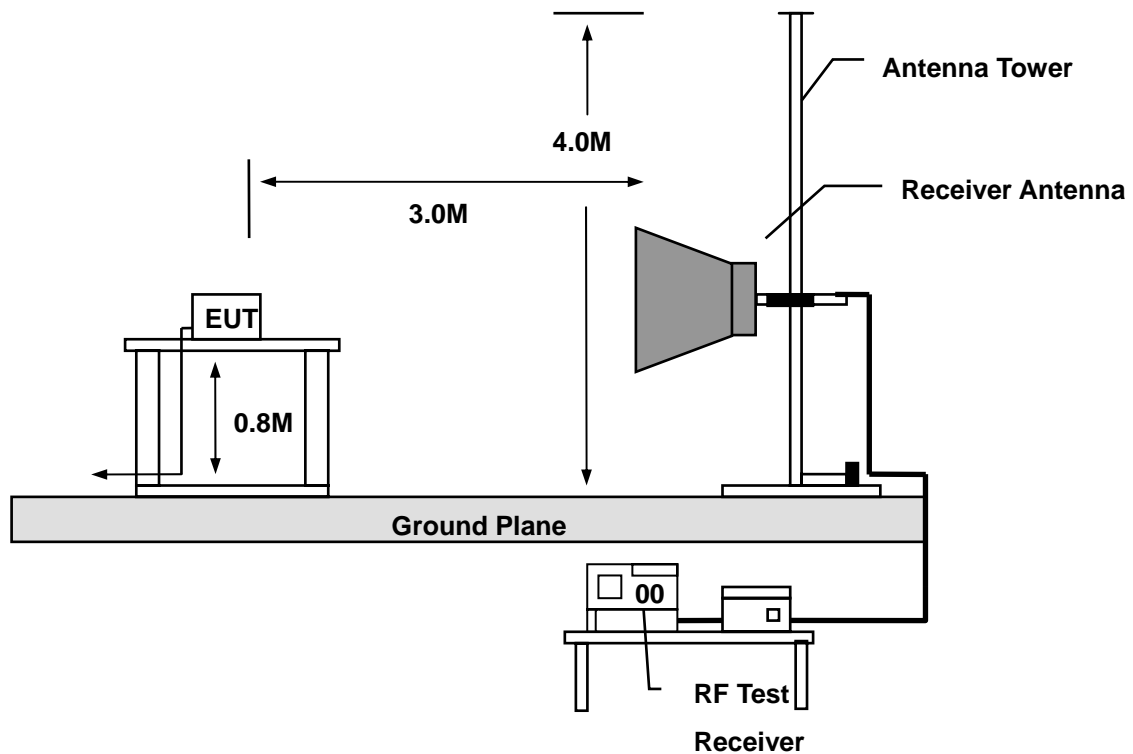

5.4. Test Procedure

Final radiation measurements were made on a three-meter, Semi Anechoic Chamber. The EUT system was placed on a nonconductive turntable which is 0.8 meters height, top surface 1.0 x 1.5 meter. The spectrum was examined from 250 MHz to 2.5 GHz in order to cover the whole spectrum below 10th harmonic which could generate from the EUT. During the test, EUT was set to transmit continuously & Measurements spectrum range from 30 MHz to 26.5 GHz is investigated.

For measurements below 1 GHz the resolution bandwidth is set to 100 kHz for peak detection measurements or 120 kHz for quasi-peak detection measurements. Peak detection is used unless otherwise noted as quasi-peak.

For measurements above 1 GHz the resolution bandwidth is set to 1 MHz, and then the video bandwidth is set to 1 MHz for peak measurements and 10 Hz for average measurements.

A nonconductive material surrounded the EUT to supporting the EUT for standing on three orthogonal planes. At each condition, the EUT was rotated 360 degrees, and the antenna was raised and lowered from one to four meters to find the maximum emission levels. Measurements were taken using both horizontal and vertical antenna polarization.

SCHWARZBECK MESS-ELEKTRONIK Biconilog Antenna (mode VULB9163) at 3 Meter and the SCHWARZBECK Double Ridged Guide Antenna (model BBHA9120D&9170) was used in frequencies 1 – 26.5 GHz at a distance of 1 meter. All test results were extrapolated to equivalent signal at 3 meters utilizing an inverse linear distance extrapolation Factor (20dB/decade).

For testing above 1GHz, the emission level of the EUT in peak mode was 20dB lower than average limit (that means the emission level in peak mode also complies with the limit in average mode), then testing will be stopped and peak values of EUT will be reported, otherwise, the emissions will be measured in average mode again and reported.

Appropriate preamplifiers were used for improving sensitivity and precautions were taken to avoid overloading or desensitizing the spectrum analyzer. No post – detector video filters were used in the test.

The spectrum analyzer's 6 dB bandwidth was set to 1 MHz, and the analyzer was operated in the peak detection mode, for frequencies both below and up 1 GHz. The average levels were obtained by subtracting the duty cycle correction factor from the peak readings.

The following procedures were used to convert the emission levels measured in decibels referenced to 1 microvolt (dBuV) into field intensity in micro volts per meter (uV/m).

The actual field intensity in decibels referenced to 1 microvolt in to field intensity in micro volts per meter (dBuV/m).

The actual field intensity in decibels referenced to 1 microvolt per meter (dBuV/m) is determined by algebraically adding the measured reading in dBuV, the antenna factor (dB), and cable loss (dB) and Subtracting the gain of preamplifier (dB) is auto calculate in spectrum analyzer.

$$(1) \text{ Amplitude (dBuV/m) = FI (dBuV) +AF (dBuV) +CL (dBuV)-Gain (dB)}$$

FI= Reading of the field intensity.

AF= Antenna factor.

CL= Cable loss.

P.S Amplitude is auto calculate in spectrum analyzer.

$$(2) \text{ Actual Amplitude (dBuV/m) = Amplitude (dBuV)-Dis(dB)}$$

The FCC specified emission limits were calculated according the EUT operating frequency and by following linear interpolation equations:

(a) For fundamental frequency : Transmitter Output < +30dBm

(b) For spurious frequency : Spurious emission limits = fundamental emission limit /10

5.5. Test Result

Below 1GHz

Standard:	FCC Part 15C	Test Distance:	3m
Test item:	Radiated Emission	Power:	AC 120V/60Hz
Model Number:	AR5B97	Temp.(°C)/Hum.(%RH):	26(°C)/60%RH
Mode:	Mode 1	Date:	2011/03/30
Ant.Polar.:	Horizontal	Test By:	Gary Wu

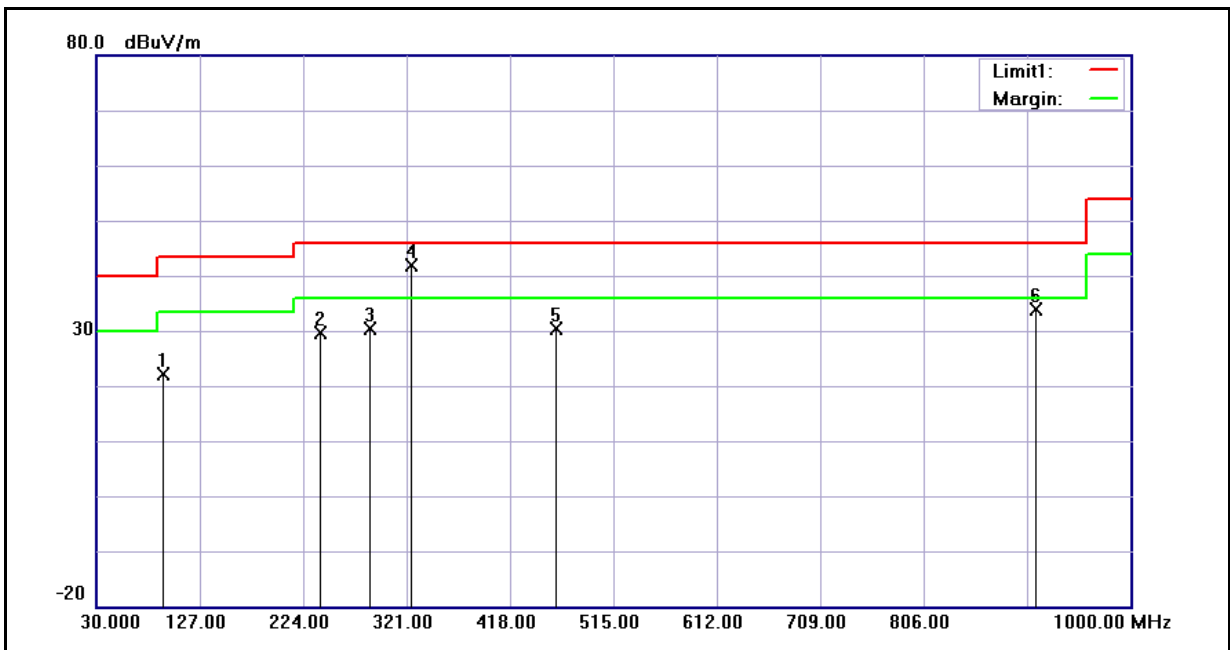

No.	Frequency (MHz)	Reading (dBuV)	Correct Factor(dB/m)	Result (dBuV/m)	Limit (dBuV/m)	Margin (dB)	Remark
1	92.5000	37.24	-15.23	22.01	43.50	-21.49	QP
2	240.0000	41.69	-12.15	29.54	46.00	-16.46	QP
3	288.0000	41.15	-10.85	30.30	46.00	-15.70	QP
4	326.5000	51.37	-9.47	41.90	46.00	-4.10	QP
5	461.0000	38.01	-7.65	30.36	46.00	-15.64	QP
6	912.0000	33.52	0.42	33.94	46.00	-12.06	QP

Standard:	FCC Part 15C	Test Distance:	3m
Test item:	Radiated Emission	Power:	AC 120V/60Hz
Model Number:	AR5B97	Temp.(°C)/Hum.(%RH):	26(°C)/60%RH
Mode:	Mode 1	Date:	2011/03/30
Ant.Polar.:	Vertical	Test By:	Gary Wu

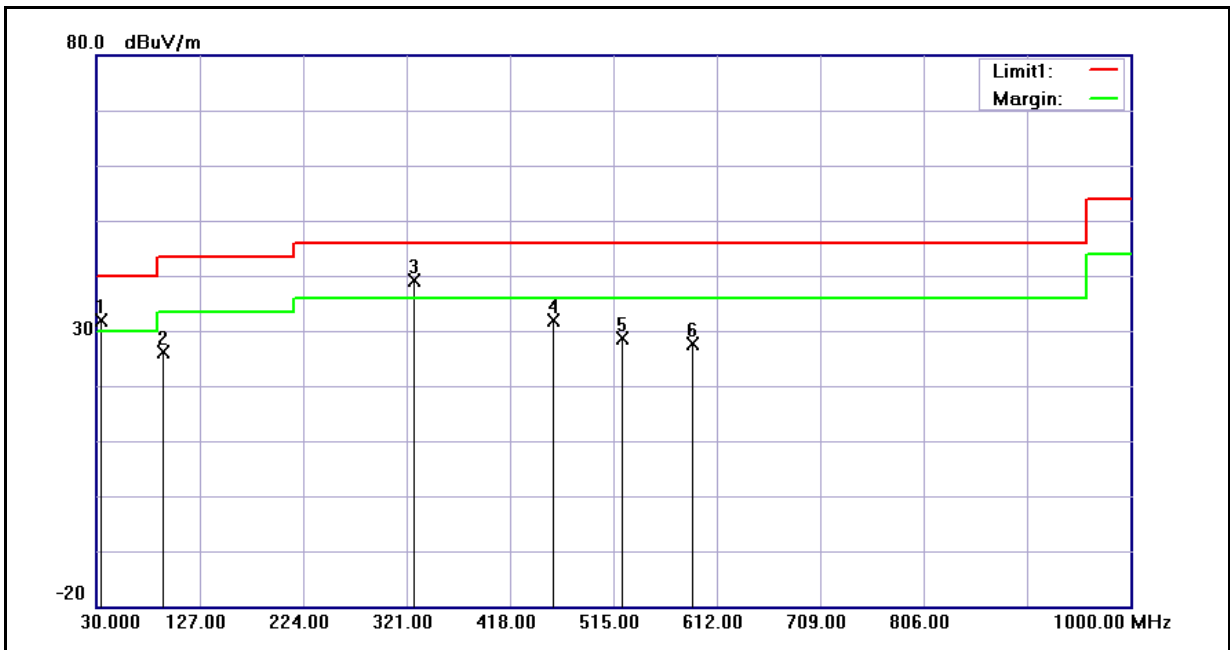

No.	Frequency (MHz)	Reading (dBuV)	Correct Factor(dB/m)	Result (dBuV/m)	Limit (dBuV/m)	Margin (dB)	Remark
1	35.0000	45.02	-13.15	31.87	40.00	-8.13	QP
2	92.5000	41.25	-15.23	26.02	43.50	-17.48	QP
3	328.0000	48.43	-9.40	39.03	46.00	-6.97	QP
4	459.0000	39.66	-7.71	31.95	46.00	-14.05	QP
5	524.5000	35.12	-6.47	28.65	46.00	-17.35	QP
6	590.0000	32.83	-5.12	27.71	46.00	-18.29	QP

Above 1GHz

Standard:	FCC Part 15C			Test Distance:	3m		
Test item:	Radiated Emission			Power:	AC 120V/60Hz		
Model Number:	AR5B97			Temp.(°C)/Hum.(%RH):	26(°C)/60%RH		
Mode:	Mode 2			Date:	2011/03/30		
Frequency:	2412MHz			Test By:	Gary Wu		
Frequency (MHz)	Reading (dBuV)	Correct Factor(dB/m)	Result (dBuV/m)	Limit (dBuV/m)	Margin (dB)	Remark	Ant.Polar. H / V
1602.000	52.35	-3.20	49.15	74.00	-24.85	peak	H
2120.000	45.99	-1.30	44.69	74.00	-29.31	peak	H
6838.000	35.88	13.93	49.81	74.00	-24.19	peak	H
1994.000	48.98	-1.81	47.17	74.00	-26.83	peak	V
2127.000	50.63	-1.28	49.35	74.00	-24.65	AVG	V
4824.000	46.74	7.92	54.66	74.00	-19.34	peak	V
4824.000	45.01	7.92	52.93	54.00	-1.07	AVG	V

Standard:	FCC Part 15C			Test Distance:	3m		
Test item:	Radiated Emission			Power:	AC 120V/60Hz		
Model Number:	AR5B97			Temp.(°C)/Hum.(%RH):	26(°C)/60%RH		
Mode:	Mode 2			Date:	2011/03/30		
Frequency:	2437MHz			Test By:	Gary Wu		
Frequency (MHz)	Reading (dBuV)	Correct Factor(dB/m)	Result (dBuV/m)	Limit (dBuV/m)	Margin (dB)	Remark	Ant.Polar. H / V
1602.000	52.16	-3.20	48.96	74.00	-25.04	peak	H
1994.000	45.70	-1.81	43.89	74.00	-30.11	peak	H
6887.000	36.17	14.06	50.23	74.00	-23.77	peak	H
2127.000	50.55	-1.28	49.27	74.00	-24.73	peak	V
4874.000	40.70	8.09	48.79	74.00	-25.21	peak	V
4990.000	41.21	8.47	49.68	74.00	-24.32	peak	V

Standard:	FCC Part 15C			Test Distance:	3m		
Test item:	Radiated Emission			Power:	AC 120V/60Hz		
Model Number:	AR5B97			Temp.(°C)/Hum.(%RH):	26(°C)/60%RH		
Mode:	Mode 2			Date:	2011/03/30		
Frequency:	2462MHz			Test By:	Gary Wu		
Frequency (MHz)	Reading (dBuV)	Correct Factor(dB/m)	Result (dBuV/m)	Limit (dBuV/m)	Margin (dB)	Remark	Ant.Polar. H / V
1329.000	48.60	-4.51	44.09	74.00	-29.91	peak	H
1595.000	50.38	-3.22	47.16	74.00	-26.84	peak	H
2127.000	44.94	-1.28	43.66	74.00	-30.34	peak	H
1994.000	49.77	-1.81	47.96	74.00	-26.04	peak	V
2127.000	50.94	-1.28	49.66	74.00	-24.34	peak	V
4924.000	40.18	8.25	48.43	74.00	-25.57	peak	V

Standard:	FCC Part 15C			Test Distance:	3m		
Test item:	Radiated Emission			Power:	AC 120V/60Hz		
Model Number:	AR5B97			Temp.(°C)/Hum.(%RH):	26(°C)/60%RH		
Mode:	Mode 3			Date:	2011/03/30		
Frequency:	2412MHz			Test By:	Gary Wu		
Frequency (MHz)	Reading (dBuV)	Correct Factor(dB/m)	Result (dBuV/m)	Limit (dBuV/m)	Margin (dB)	Remark	Ant.Polar. H / V
1595.000	49.79	-3.22	46.57	74.00	-27.43	peak	H
2127.000	46.86	-1.28	45.58	74.00	-28.42	peak	H
7083.000	36.77	14.63	51.40	74.00	-22.60	peak	H
1994.000	51.93	-1.81	50.12	74.00	-23.88	peak	V
2120.000	49.99	-1.30	48.69	74.00	-25.31	peak	V
4824.000	40.60	7.92	48.52	74.00	-25.48	peak	V

Standard:	FCC Part 15C			Test Distance:	3m		
Test item:	Radiated Emission			Power:	AC 120V/60Hz		
Model Number:	AR5B97			Temp.(°C)/Hum.(%RH):	26(°C)/60%RH		
Mode:	Mode 3			Date:	2011/03/30		
Frequency:	2437MHz			Test By:	Gary Wu		
Frequency (MHz)	Reading (dBuV)	Correct Factor(dB/m)	Result (dBuV/m)	Limit (dBuV/m)	Margin (dB)	Remark	Ant.Polar. H / V
1329.000	50.76	-4.51	46.25	74.00	-27.75	peak	H
1595.000	51.18	-3.22	47.96	74.00	-26.04	peak	H
2001.000	47.15	-1.79	45.36	74.00	-28.64	peak	H
1329.000	56.35	-4.51	51.84	74.00	-22.16	peak	V
2127.000	50.65	-1.28	49.37	74.00	-24.63	peak	V
4874.000	42.38	8.09	50.47	74.00	-23.53	peak	V

Standard:	FCC Part 15C			Test Distance:	3m		
Test item:	Radiated Emission			Power:	AC 120V/60Hz		
Model Number:	AR5B97			Temp.(°C)/Hum.(%RH):	26(°C)/60%RH		
Mode:	Mode 3			Date:	2011/03/30		
Frequency:	2462MHz			Test By:	Gary Wu		
Frequency (MHz)	Reading (dBuV)	Correct Factor(dB/m)	Result (dBuV/m)	Limit (dBuV/m)	Margin (dB)	Remark	Ant.Polar. H / V
1595.000	52.12	-3.22	48.90	74.00	-25.10	peak	H
2127.000	48.10	-1.28	46.82	74.00	-27.18	peak	H
6999.000	37.06	14.41	51.47	74.00	-22.53	peak	H
1994.000	50.56	-1.81	48.75	74.00	-25.25	peak	V
2134.000	49.26	-1.25	48.01	74.00	-25.99	peak	V
4990.000	39.94	8.47	48.41	74.00	-25.59	peak	V

Standard:	FCC Part 15C			Test Distance:	3m		
Test item:	Radiated Emission			Power:	AC 120V/60Hz		
Model Number:	AR5B97			Temp.(°C)/Hum.(%RH):	26(°C)/60%RH		
Mode:	Mode 4			Date:	2011/03/30		
Frequency:	2412MHz			Test By:	Gary Wu		
Frequency (MHz)	Reading (dBuV)	Correct Factor(dB/m)	Result (dBuV/m)	Limit (dBuV/m)	Margin (dB)	Remark	Ant.Polar. H / V
1595.000	52.70	-3.22	49.48	74.00	-24.52	peak	H
2127.000	46.16	-1.28	44.88	74.00	-29.12	peak	H
6747.000	36.17	13.64	49.81	74.00	-24.19	peak	H
1994.000	50.12	-1.81	48.31	74.00	-25.69	peak	V
2127.000	50.03	-1.28	48.75	74.00	-25.25	peak	V
4983.000	43.18	8.45	51.63	74.00	-22.37	peak	V

Standard:	FCC Part 15C			Test Distance:	3m		
Test item:	Radiated Emission			Power:	AC 120V/60Hz		
Model Number:	AR5B97			Temp.(°C)/Hum.(%RH):	26(°C)/60%RH		
Mode:	Mode 4			Date:	2011/03/30		
Frequency:	2437MHz			Test By:	Gary Wu		
Frequency (MHz)	Reading (dBuV)	Correct Factor(dB/m)	Result (dBuV/m)	Limit (dBuV/m)	Margin (dB)	Remark	Ant.Polar. H / V
1595.000	52.55	-3.22	49.33	74.00	-24.67	peak	H
1994.000	47.90	-1.81	46.09	74.00	-27.91	peak	H
2127.000	48.14	-1.28	46.86	74.00	-27.14	peak	H
2127.000	50.96	-1.28	49.68	74.00	-24.32	peak	V
4874.000	43.22	8.09	51.31	74.00	-22.69	peak	V
4990.000	42.22	8.47	50.69	74.00	-23.31	peak	V

Standard:	FCC Part 15C			Test Distance:	3m		
Test item:	Radiated Emission			Power:	AC 120V/60Hz		
Model Number:	AR5B97			Temp.(°C)/Hum.(%RH):	26(°C)/60%RH		
Mode:	Mode 4			Date:	2011/03/30		
Frequency:	2462MHz			Test By:	Gary Wu		
Frequency (MHz)	Reading (dBuV)	Correct Factor(dB/m)	Result (dBuV/m)	Limit (dBuV/m)	Margin (dB)	Remark	Ant.Polar. H / V
1336.000	53.54	-4.48	49.06	74.00	-24.94	peak	H
1595.000	52.91	-3.22	49.69	74.00	-24.31	peak	H
2134.000	46.32	-1.25	45.07	74.00	-28.93	peak	H
1994.000	50.96	-1.81	49.15	74.00	-24.85	peak	V
2127.000	50.67	-1.28	49.39	74.00	-24.61	peak	V
4976.000	43.50	8.42	51.92	74.00	-22.08	peak	V

Standard:	FCC Part 15C			Test Distance:	3m		
Test item:	Radiated Emission			Power:	AC 120V/60Hz		
Model Number:	AR5B97			Temp.(°C)/Hum.(%RH):	26(°C)/60%RH		
Mode:	Mode 5			Date:	2011/03/30		
Frequency:	2422MHz			Test By:	Gary Wu		
Frequency (MHz)	Reading (dBuV)	Correct Factor(dB/m)	Result (dBuV/m)	Limit (dBuV/m)	Margin (dB)	Remark	Ant.Polar. H / V
1595.000	52.96	-3.22	49.74	74.00	-24.26	peak	H
2120.000	50.21	-1.30	48.91	74.00	-25.09	peak	H
6782.000	36.06	13.74	49.80	74.00	-24.20	peak	H
1994.000	50.63	-1.81	48.82	74.00	-25.18	peak	V
2127.000	49.11	-1.28	47.83	74.00	-26.17	peak	V
4983.000	43.13	8.45	51.58	74.00	-22.42	peak	V

Standard:	FCC Part 15C			Test Distance:	3m		
Test item:	Radiated Emission			Power:	AC 120V/60Hz		
Model Number:	AR5B97			Temp.(°C)/Hum.(%RH):	26(°C)/60%RH		
Mode:	Mode 5			Date:	2011/03/30		
Frequency:	2437MHz			Test By:	Gary Wu		
Frequency (MHz)	Reading (dBuV)	Correct Factor(dB/m)	Result (dBuV/m)	Limit (dBuV/m)	Margin (dB)	Remark	Ant.Polar. H / V
1595.000	50.51	-3.22	47.29	74.00	-26.71	peak	H
2127.000	47.00	-1.28	45.72	74.00	-28.28	peak	H
6775.000	36.99	13.73	50.72	74.00	-23.28	peak	H
1329.000	54.82	-4.51	50.31	74.00	-23.69	peak	V
1994.000	50.57	-1.81	48.76	74.00	-25.24	peak	V
4997.000	43.18	8.49	51.67	74.00	-22.33	peak	V

Standard:	FCC Part 15C			Test Distance:	3m		
Test item:	Radiated Emission			Power:	AC 120V/60Hz		
Model Number:	AR5B97			Temp.(°C)/Hum.(%RH):	26(°C)/60%RH		
Mode:	Mode 5			Date:	2011/03/30		
Frequency:	2452MHz			Test By:	Gary Wu		
Frequency (MHz)	Reading (dBuV)	Correct Factor(dB/m)	Result (dBuV/m)	Limit (dBuV/m)	Margin (dB)	Remark	Ant.Polar. H / V
1595.000	49.12	-3.22	45.90	74.00	-28.10	peak	H
2127.000	45.52	-1.28	44.24	74.00	-29.76	peak	H
7055.000	36.72	14.56	51.28	74.00	-22.72	peak	H
1994.000	49.14	-1.81	47.33	74.00	-26.67	peak	V
2127.000	49.28	-1.28	48.00	74.00	-26.00	peak	V
4997.000	39.54	8.49	48.03	74.00	-25.97	peak	V

Standard:	FCC Part 15B		Test Distance:	3m				
Test item:	Radiated Emission		Power:	AC 120V/60Hz				
Model Number:	AR5B97		Temp.(°C)/Hum.(%RH):	26(°C)/60%RH				
Mode:	Mode 6		Date:	2011/03/30				
Frequency:	2437MHz		Test By:	Gary Wu				
Frequency (MHz)	Reading (dBuV)	Correct Factor(dB/m)	Result (dBuV/m)	Peak Limit (dBuV/m)	AVG. Limit (dBuV/m)	Margin (dB)	Remark	Ant.Polar. H / V
1595.000	50.12	-3.22	46.90	74.00	54.00	-27.10	peak	H
4920.000	36.38	8.24	44.62	74.00	54.00	-29.38	peak	H
7076.000	36.18	14.61	50.79	74.00	54.00	-23.21	peak	H
2127.000	48.76	-1.28	47.48	74.00	54.00	-26.52	peak	V
3191.000	42.18	2.72	44.90	74.00	54.00	-29.10	peak	V
6705.000	35.49	13.51	49.00	74.00	54.00	-25.00	peak	V

6 Band Edges Measurement

6.1. Limit

In any 100 kHz bandwidth outside the intentional radiation frequency band, the radio frequency power shall be at least 20 dB below the highest level of the radiated power. In addition, radiated emissions which fall in the restricted bands must also comply with the radiated emission limits.

6.2. Test Setup

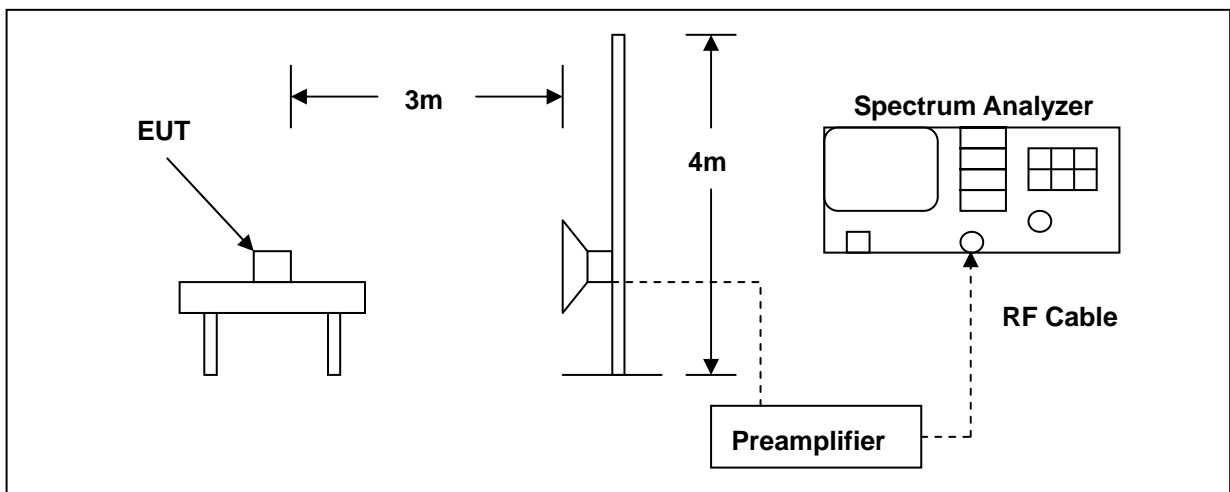

6.3. Test Instruments

Equipment	Manufacturer	Model Number	Serial Number	Cal. Date	Remark
Spectrum Analyzer	Agilent	E4408B	MY45107753	06/24/2010	(1)
Pre Amplifier	Agilent	8449B	3008A02237	02/23/2011	(1)
Horn Antenna	SCHWARZBECK MESS-ELEKTRONIK	9120D	9120D-550	06/29/2010	(2)
Test Site	ATL	TE06	TE06	N.C.R.	-----

Remark: ⁽¹⁾ Calibration period 1 year. ⁽²⁾ Calibration period 2 years.

NOTE: N.C.R. = No Calibration Request.

6.4. Test Procedure

The EUT was setup to ANSI C63.4, 2003; tested to DTS test procedure of Oct 2002 KDB558074 for compliance to FCC 47CFR 15.247 requirements.

The emissions on the harmonics frequencies, the limits, and the margin of compliance are presented. These tests were made when the transmitter was in full radiated power. The additional test was performed to show compliance with the requirement at the band-edge frequency 2483.5 MHz and up to 2500 MHz and at 2390.0 MHz.

The transmitter was configured with the worst case antenna and setup to transmit at the highest channel. Then the field strength was measured at 2483.5 MHz.

The transmitter was then configured with the worst case antenna and setup to transmit at the lowest channel. Then the field strength was measured at 2390.0 MHz. These tests were performed at 4 different bit rates.

6.5. Test Result

Standard:	FCC Part 15C	Test Distance:	3m
Test item:	Radiated Emission	Power:	AC 120V/60Hz
Model Number:	AR5B97	Temp.(°C)/Hum.(%RH):	26(°C)/60%RH
Mode:	Mode 2	Date:	2011/03/30
Frequency:	2412 MHz	Test By:	Gary Wu
Ant.Polar.:	Horizontal		

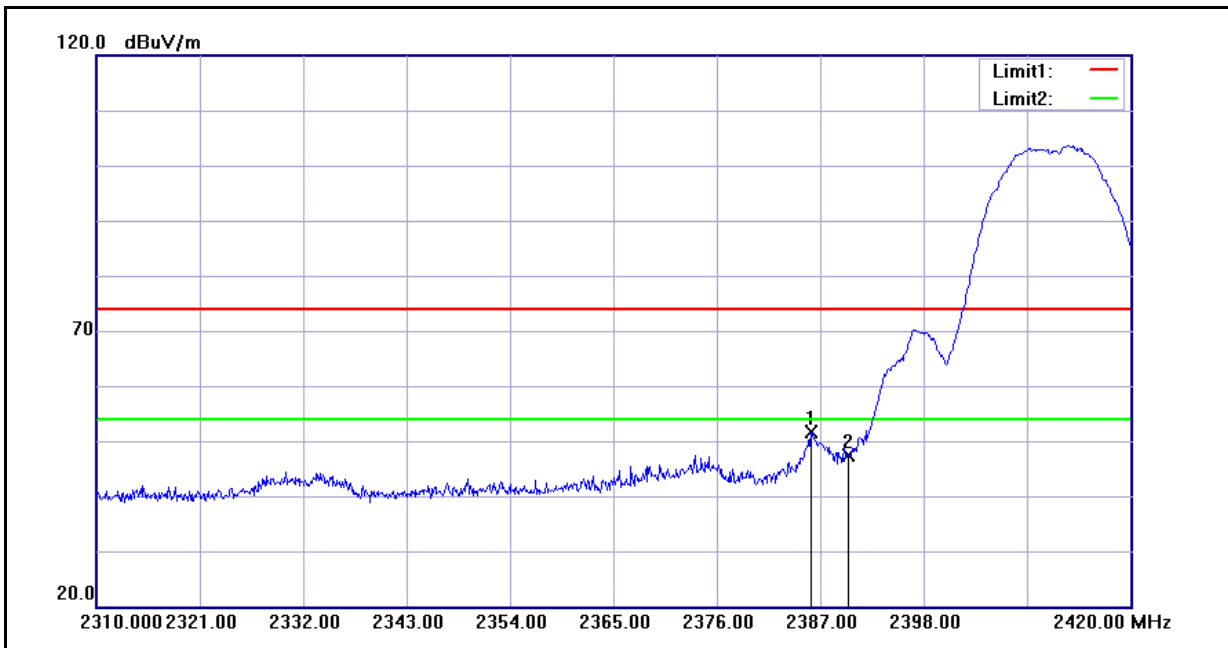

No.	Frequency (MHz)	Reading (dBuV)	Correct Factor(dB/m)	Result (dBuV/m)	Limit (dBuV/m)	Margin (dB)	Remark
1	2386.010	51.97	-0.24	51.73	74.00	-22.27	peak
2	2390.000	47.63	-0.22	47.41	74.00	-26.59	peak

Standard:	FCC Part 15C	Test Distance:	3m
Test item:	Radiated Emission	Power:	AC 120V/60Hz
Model Number:	AR5B97	Temp.(°C)/Hum.(%RH):	26(°C)/60%RH
Mode:	Mode 2	Date:	2011/03/30
Frequency:	2412 MHz	Test By:	Gary Wu
Ant.Polar.:	Vertical		

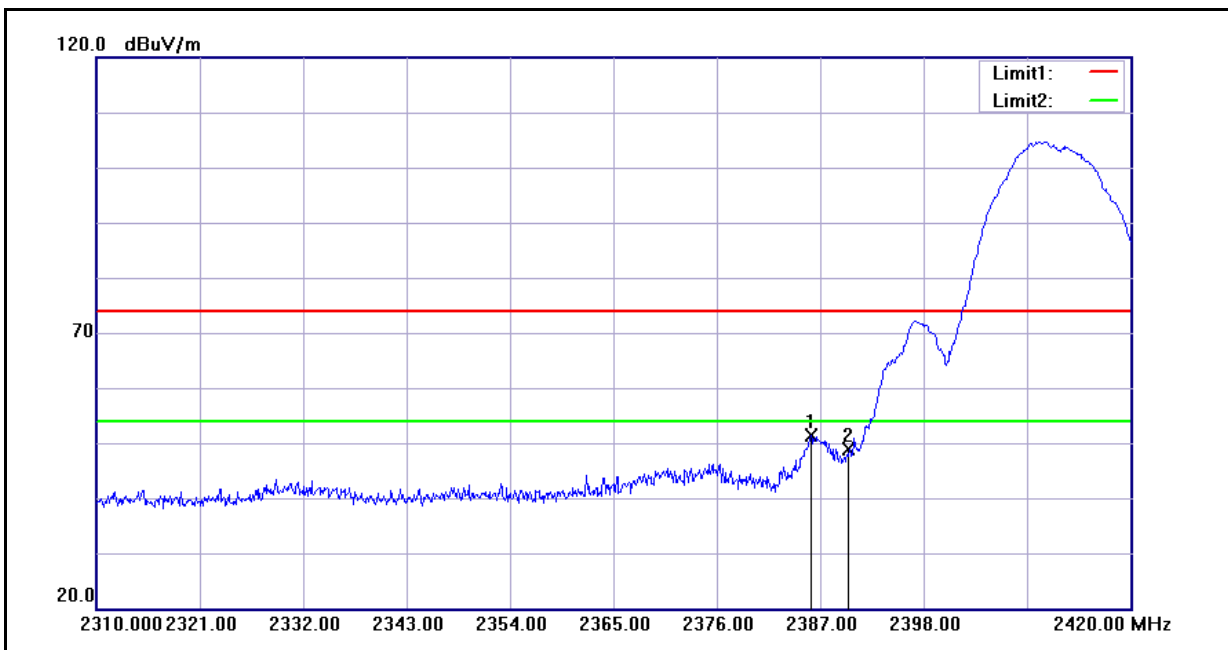

No.	Frequency (MHz)	Reading (dBuV)	Correct Factor(dB/m)	Result (dBuV/m)	Limit (dBuV/m)	Margin (dB)	Remark
1	2386.010	51.63	-0.24	51.39	74.00	-22.61	peak
2	2390.000	49.17	-0.22	48.95	74.00	-25.05	peak

Standard:	FCC Part 15C	Test Distance:	3m
Test item:	Radiated Emission	Power:	AC 120V/60Hz
Model Number:	AR5B97	Temp.(°C)/Hum.(%RH):	26(°C)/60%RH
Mode:	Mode 2	Date:	2011/03/30
Frequency:	2462 MHz	Test By:	Gary Wu
Ant.Polar.:	Horizontal		

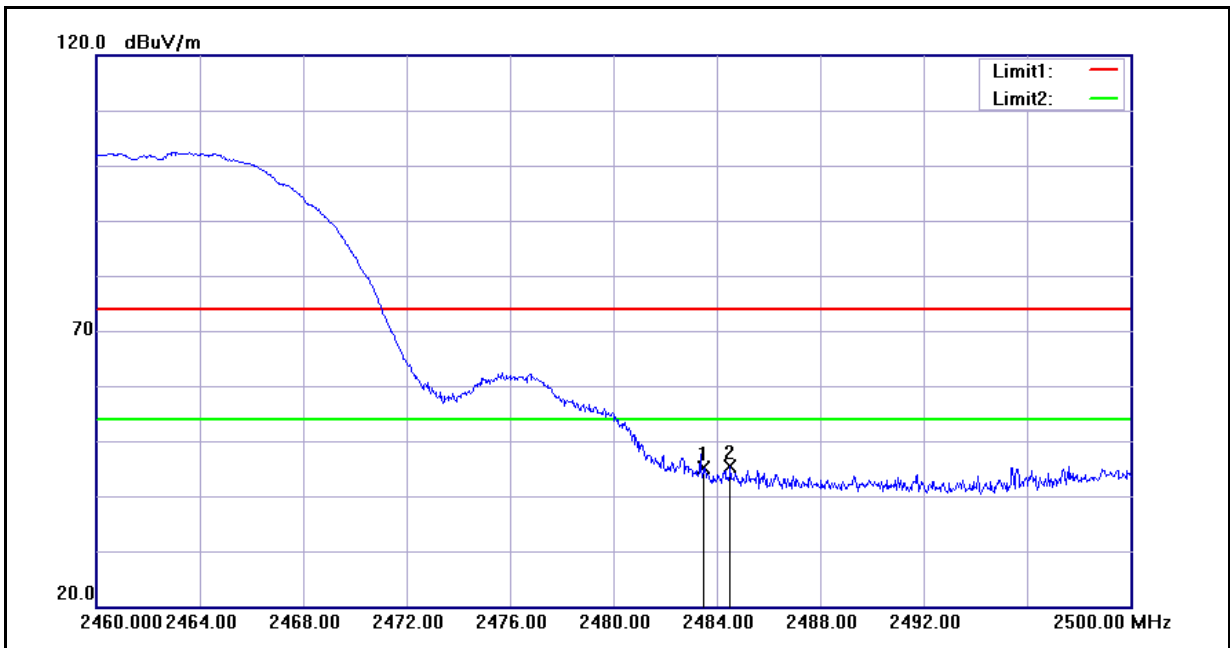

No.	Frequency (MHz)	Reading (dBuV)	Correct Factor(dB/m)	Result (dBuV/m)	Limit (dBuV/m)	Margin (dB)	Remark
1	2483.500	44.88	0.16	45.04	74.00	-28.96	peak
2	2484.520	45.18	0.16	45.34	74.00	-28.66	peak

Standard:	FCC Part 15C	Test Distance:	3m
Test item:	Radiated Emission	Power:	AC 120V/60Hz
Model Number:	AR5B97	Temp.(°C)/Hum.(%RH):	26(°C)/60%RH
Mode:	Mode 2	Date:	2011/03/30
Frequency:	2462 MHz	Test By:	Gary Wu
Ant.Polar.:	Vertical		

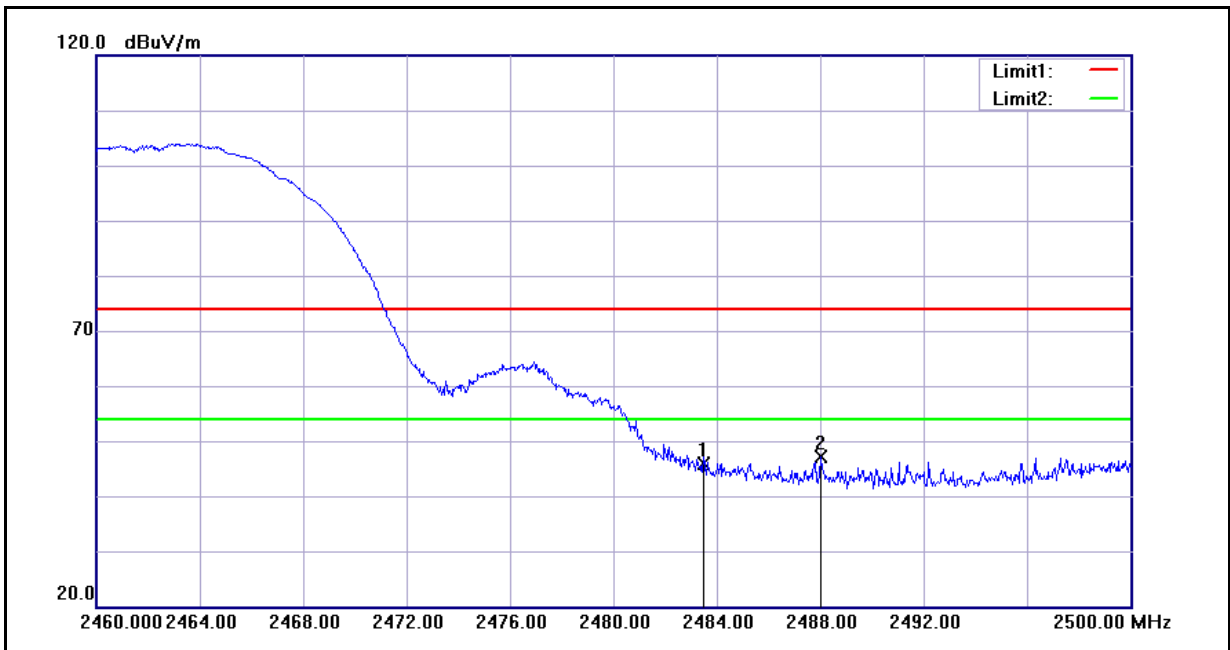

No.	Frequency (MHz)	Reading (dBuV)	Correct Factor(dB/m)	Result (dBuV/m)	Limit (dBuV/m)	Margin (dB)	Remark
1	2483.500	45.84	0.16	46.00	74.00	-28.00	peak
2	2488.040	47.00	0.18	47.18	74.00	-26.82	peak

Standard:	FCC Part 15C	Test Distance:	3m
Test item:	Radiated Emission	Power:	AC 120V/60Hz
Model Number:	AR5B97	Temp.(°C)/Hum.(%RH):	26(°C)/60%RH
Mode:	Mode 3	Date:	2011/03/30
Frequency:	2412 MHz	Test By:	Gary Wu
Ant.Polar.:	Horizontal		

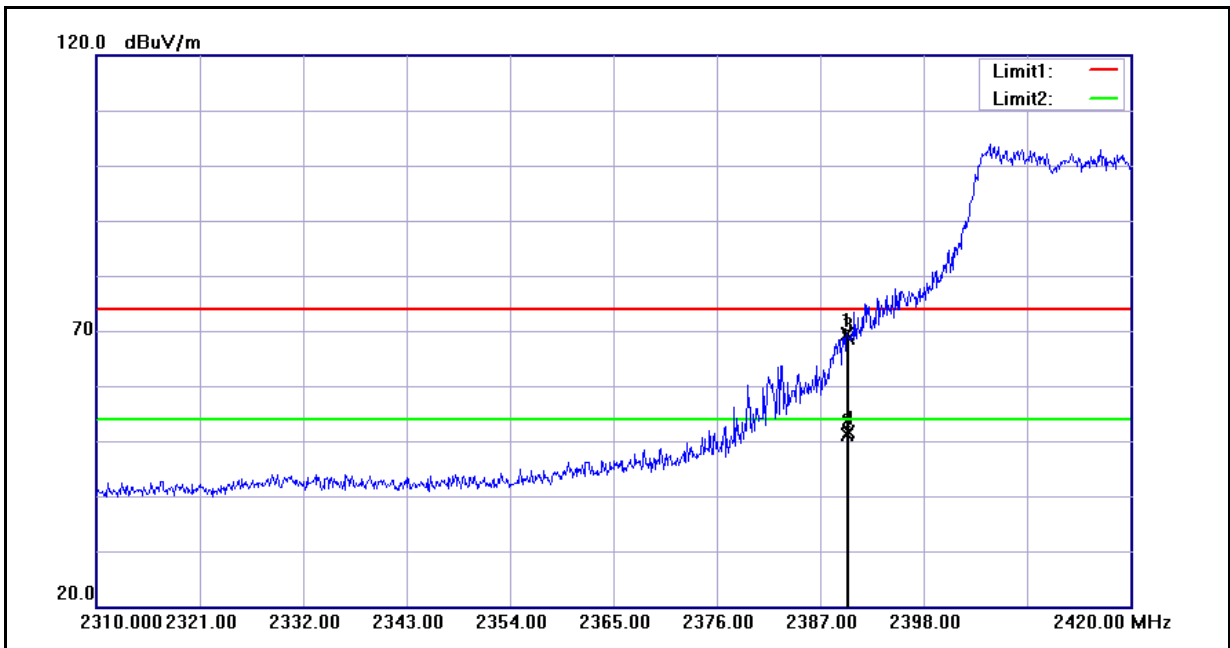

No.	Frequency (MHz)	Reading (dBuV)	Correct Factor(dB/m)	Result (dBuV/m)	Limit (dBuV/m)	Margin (dB)	Remark
1	2389.860	69.70	-0.22	69.48	74.00	-4.52	peak
2	2389.860	51.37	-0.22	51.15	54.00	-2.85	AVG
3	2390.000	68.88	-0.22	68.66	74.00	-5.34	peak
4	2390.000	51.74	-0.22	51.52	54.00	-2.48	AVG

Standard:	FCC Part 15C	Test Distance:	3m
Test item:	Radiated Emission	Power:	AC 120V/60Hz
Model Number:	AR5B97	Temp.(°C)/Hum.(%RH):	26(°C)/60%RH
Mode:	Mode 3	Date:	2011/03/30
Frequency:	2412 MHz	Test By:	Gary Wu
Ant.Polar.:	Vertical		

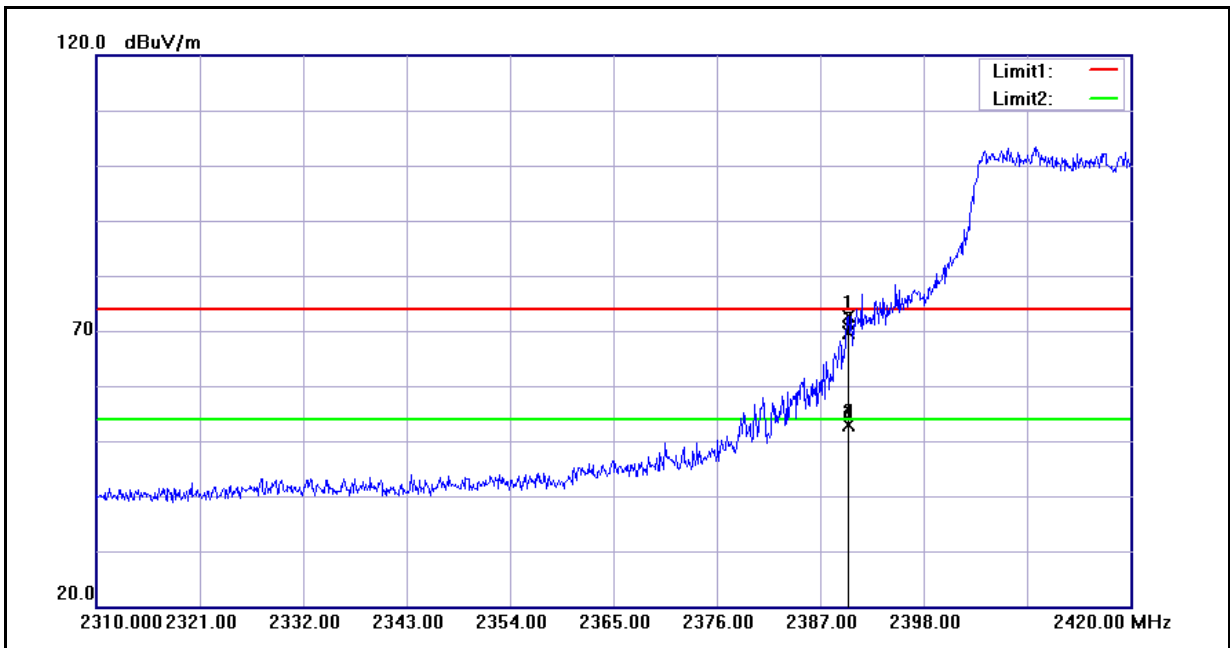

No.	Frequency (MHz)	Reading (dBuV)	Correct Factor(dB/m)	Result (dBuV/m)	Limit (dBuV/m)	Margin (dB)	Remark
1	2389.970	72.97	-0.22	72.75	74.00	-1.25	peak
2	2389.970	52.98	-0.22	52.76	54.00	-1.24	AVG
3	2390.000	69.88	-0.22	69.66	74.00	-4.34	peak
4	2390.000	52.98	-0.22	52.76	54.00	-1.24	AVG

Standard:	FCC Part 15C	Test Distance:	3m
Test item:	Radiated Emission	Power:	AC 120V/60Hz
Model Number:	AR5B97	Temp.(°C)/Hum.(%RH):	26(°C)/60%RH
Mode:	Mode 3	Date:	2011/03/30
Frequency:	2462 MHz	Test By:	Gary Wu
Ant.Polar.:	Horizontal		

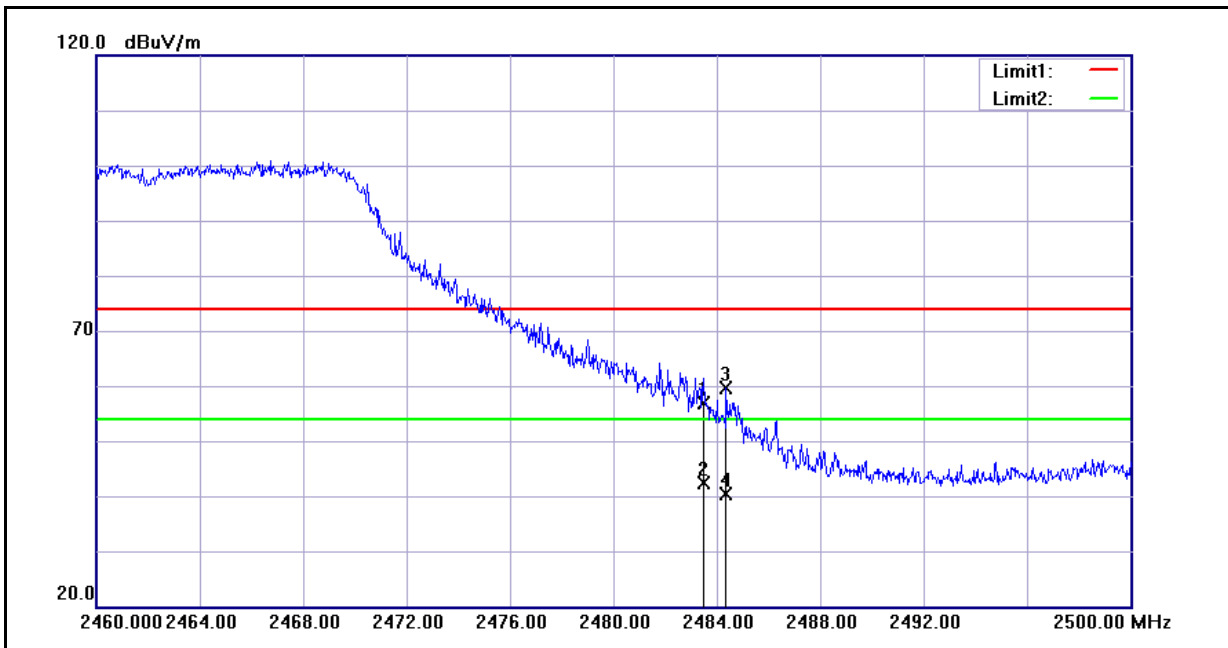

No.	Frequency (MHz)	Reading (dBuV)	Correct Factor(dB/m)	Result (dBuV/m)	Limit (dBuV/m)	Margin (dB)	Remark
1	2483.500	56.81	0.16	56.97	74.00	-17.03	peak
2	2483.500	42.23	0.16	42.39	54.00	-11.61	AVG
3	2484.360	59.50	0.16	59.66	74.00	-14.34	peak
4	2484.360	40.15	0.16	40.31	54.00	-13.69	AVG

Standard:	FCC Part 15C	Test Distance:	3m
Test item:	Radiated Emission	Power:	AC 120V/60Hz
Model Number:	AR5B97	Temp.(°C)/Hum.(%RH):	26(°C)/60%RH
Mode:	Mode 3	Date:	2011/03/30
Frequency:	2462 MHz	Test By:	Gary Wu
Ant.Polar.:	Vertical		

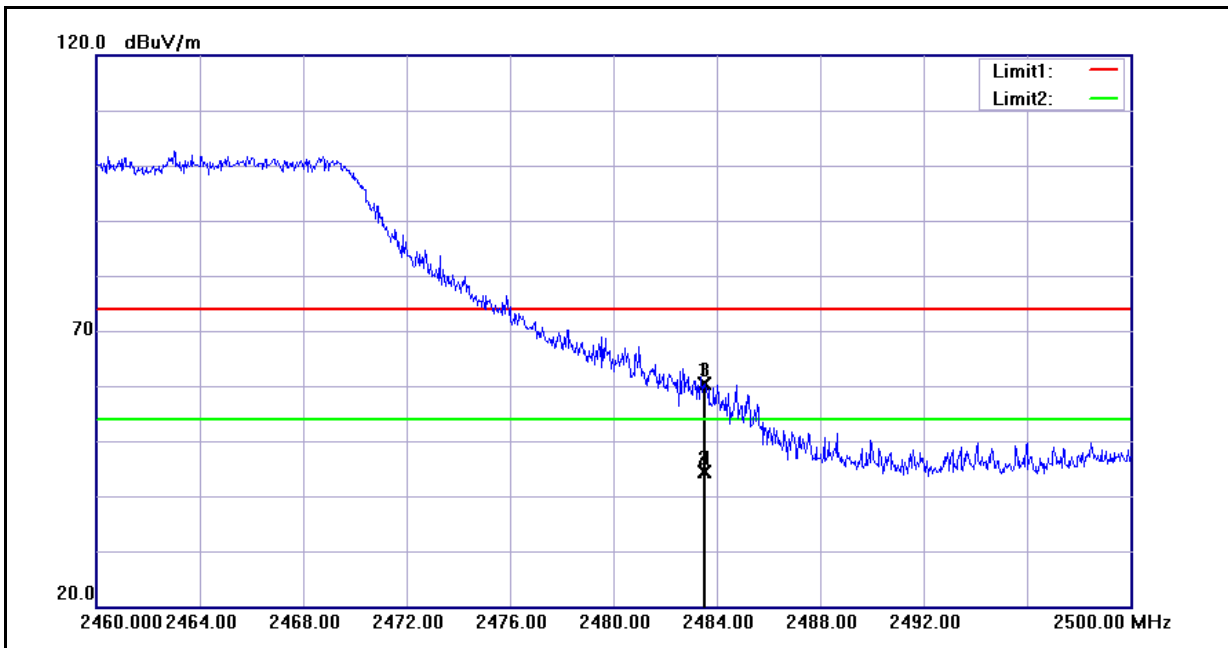

No.	Frequency (MHz)	Reading (dBuV)	Correct Factor(dB/m)	Result (dBuV/m)	Limit (dBuV/m)	Margin (dB)	Remark
1	2483.500	60.16	0.16	60.32	74.00	-13.68	peak
2	2483.500	44.18	0.16	44.34	54.00	-9.66	AVG
3	2483.520	60.16	0.16	60.32	74.00	-13.68	peak
4	2483.520	44.19	0.16	44.35	54.00	-9.65	AVG

Standard:	FCC Part 15C	Test Distance:	3m
Test item:	Radiated Emission	Power:	AC 120V/60Hz
Model Number:	AR5B97	Temp.(°C)/Hum.(%RH):	26(°C)/60%RH
Mode:	Mode 4	Date:	2011/03/30
Frequency:	2412 MHz	Test By:	Gary Wu
Ant.Polar.:	Horizontal		

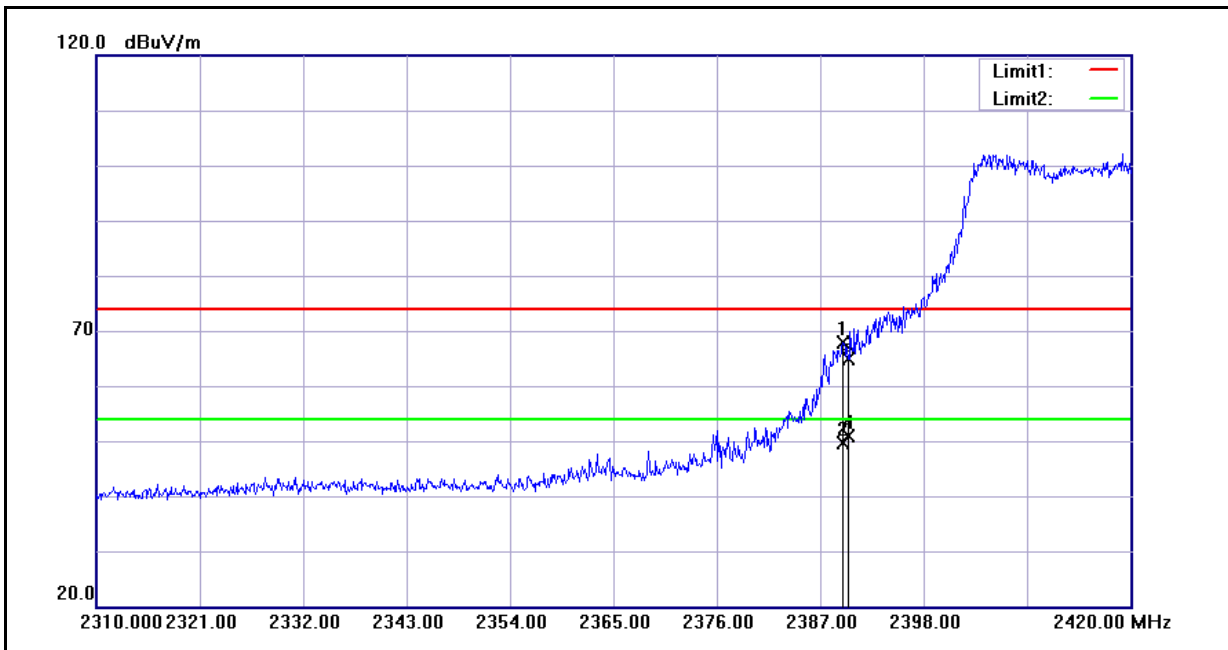

No.	Frequency (MHz)	Reading (dBuV)	Correct Factor(dB/m)	Result (dBuV/m)	Limit (dBuV/m)	Margin (dB)	Remark
1	2389.420	68.15	-0.22	67.93	74.00	-6.07	peak
2	2389.420	49.75	-0.22	49.53	54.00	-4.47	AVG
3	2390.000	65.14	-0.22	64.92	74.00	-9.08	peak
4	2390.000	50.99	-0.22	50.77	54.00	-3.23	AVG

Standard:	FCC Part 15C	Test Distance:	3m
Test item:	Radiated Emission	Power:	AC 120V/60Hz
Model Number:	AR5B97	Temp.(°C)/Hum.(%RH):	26(°C)/60%RH
Mode:	Mode 4	Date:	2011/03/30
Frequency:	2412 MHz	Test By:	Gary Wu
Ant.Polar.:	Vertical		

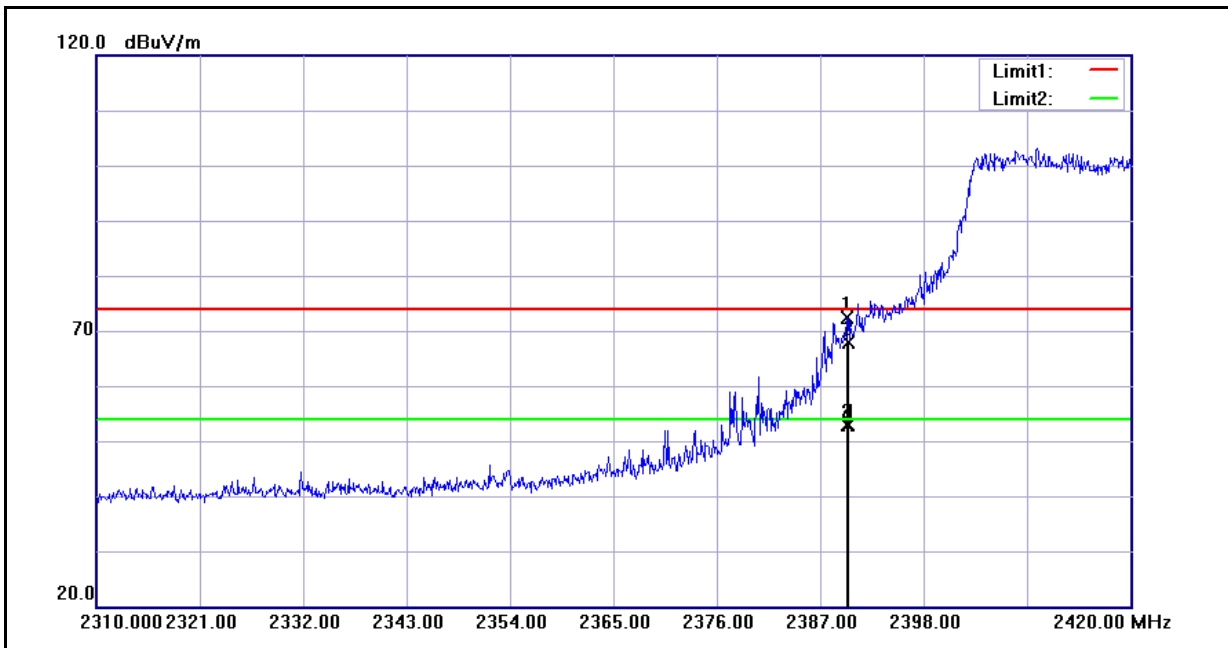

No.	Frequency (MHz)	Reading (dBuV)	Correct Factor(dB/m)	Result (dBuV/m)	Limit (dBuV/m)	Margin (dB)	Remark
1	2389.860	72.63	-0.22	72.41	74.00	-1.59	peak
2	2389.860	53.11	-0.22	52.89	54.00	-1.11	AVG
3	2390.000	68.22	-0.22	68.00	74.00	-6.00	peak
4	2390.000	53.14	-0.22	52.92	54.00	-1.08	AVG

Standard:	FCC Part 15C	Test Distance:	3m
Test item:	Radiated Emission	Power:	AC 120V/60Hz
Model Number:	AR5B97	Temp.(°C)/Hum.(%RH):	26(°C)/60%RH
Mode:	Mode 4	Date:	2011/03/30
Frequency:	2462 MHz	Test By:	Gary Wu
Ant.Polar.:	Horizontal		

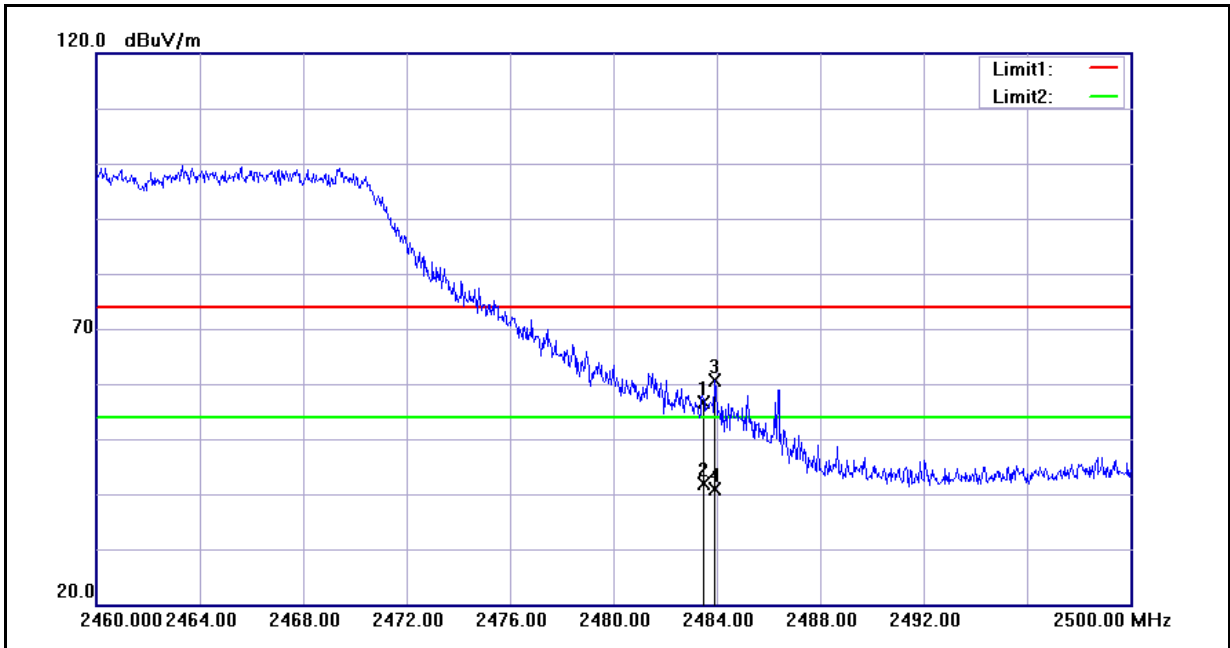

No.	Frequency (MHz)	Reading (dBuV)	Correct Factor(dB/m)	Result (dBuV/m)	Limit (dBuV/m)	Margin (dB)	Remark
1	2483.500	56.50	0.16	56.66	74.00	-17.34	peak
2	2483.500	41.68	0.16	41.84	54.00	-12.16	AVG
3	2483.920	60.51	0.16	60.67	74.00	-13.33	peak
4	2483.920	40.84	0.16	41.00	54.00	-13.00	AVG

Standard:	FCC Part 15C	Test Distance:	3m
Test item:	Radiated Emission	Power:	AC 120V/60Hz
Model Number:	AR5B97	Temp.(°C)/Hum.(%RH):	26(°C)/60%RH
Mode:	Mode 4	Date:	2011/03/30
Frequency:	2462 MHz	Test By:	Gary Wu
Ant.Polar.:	Vertical		

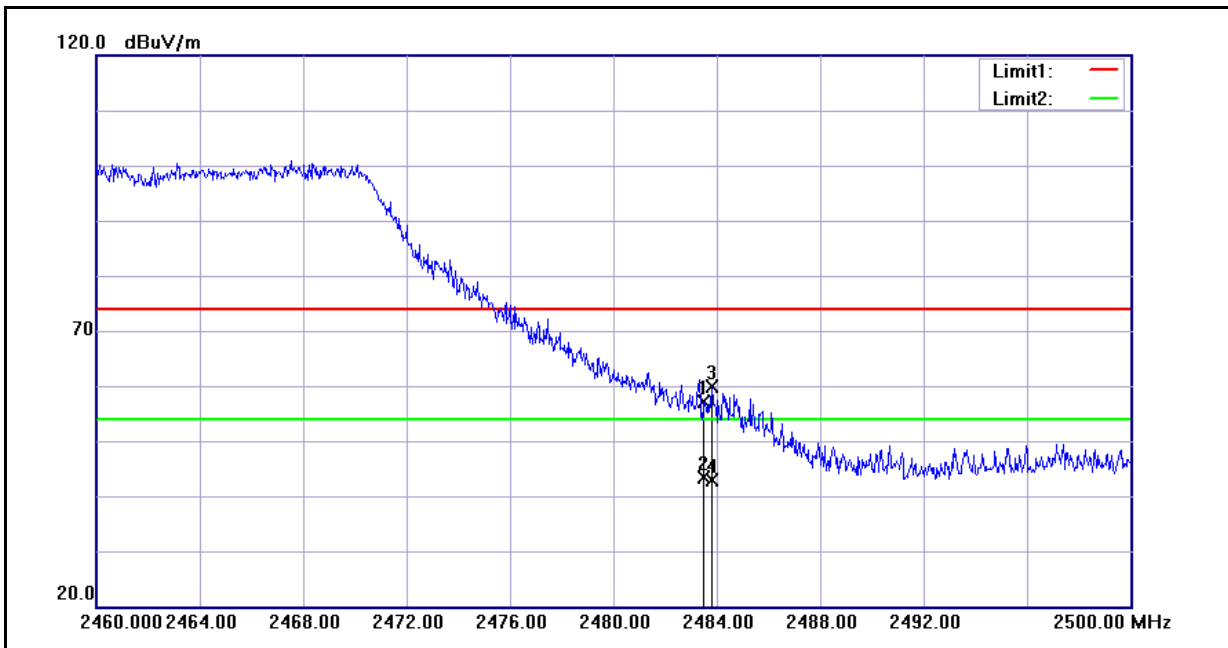

No.	Frequency (MHz)	Reading (dBuV)	Correct Factor(dB/m)	Result (dBuV/m)	Limit (dBuV/m)	Margin (dB)	Remark
1	2483.500	56.85	0.16	57.01	74.00	-16.99	peak
2	2483.500	43.10	0.16	43.26	54.00	-10.74	AVG
3	2483.800	59.69	0.16	59.85	74.00	-14.15	peak
4	2483.800	42.75	0.16	42.91	54.00	-11.09	AVG

Standard:	FCC Part 15C	Test Distance:	3m
Test item:	Radiated Emission	Power:	AC 120V/60Hz
Model Number:	AR5B97	Temp.(°C)/Hum.(%RH):	26(°C)/60%RH
Mode:	Mode 5	Date:	2011/03/30
Frequency:	2422 MHz	Test By:	Gary Wu
Ant.Polar.:	Horizontal		

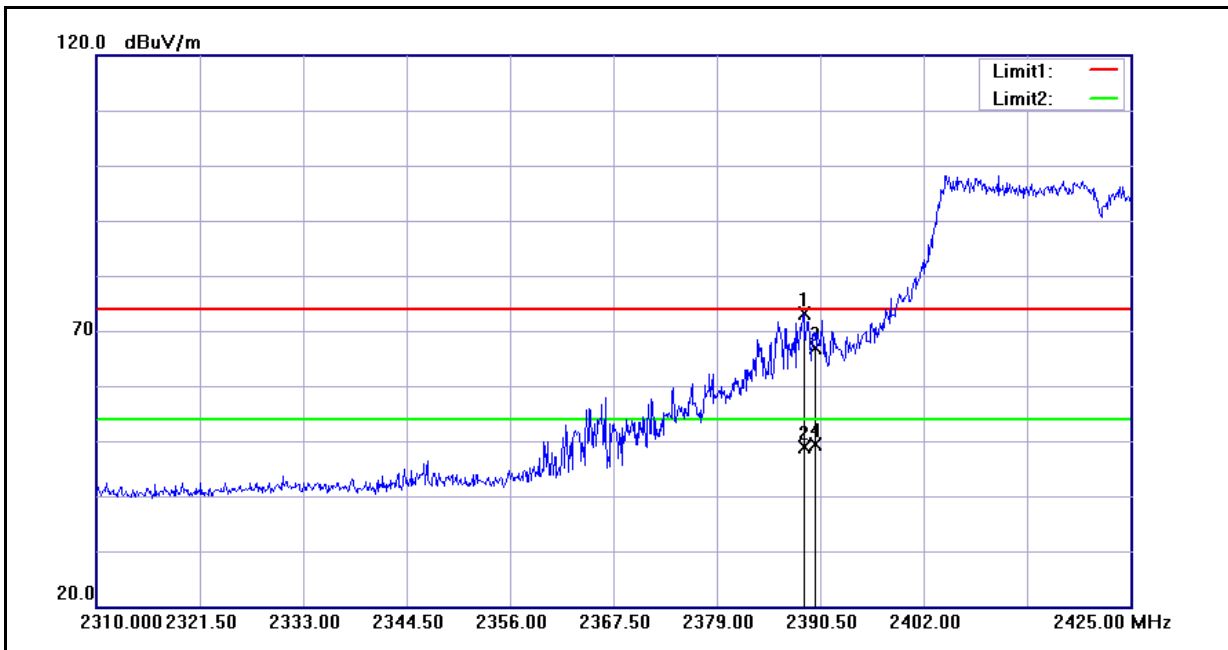

No.	Frequency (MHz)	Reading (dBuV)	Correct Factor(dB/m)	Result (dBuV/m)	Limit (dBuV/m)	Margin (dB)	Remark
1	2388.660	73.27	-0.22	73.05	74.00	-0.95	peak
2	2388.660	49.20	-0.22	48.98	54.00	-5.02	AVG
3	2390.000	67.05	-0.22	66.83	74.00	-7.17	peak
4	2390.000	49.59	-0.22	49.37	54.00	-4.63	AVG

Standard:	FCC Part 15C	Test Distance:	3m
Test item:	Radiated Emission	Power:	AC 120V/60Hz
Model Number:	AR5B97	Temp.(°C)/Hum.(%RH):	26(°C)/60%RH
Mode:	Mode 5	Date:	2011/03/30
Frequency:	2422 MHz	Test By:	Gary Wu
Ant.Polar.:	Vertical		

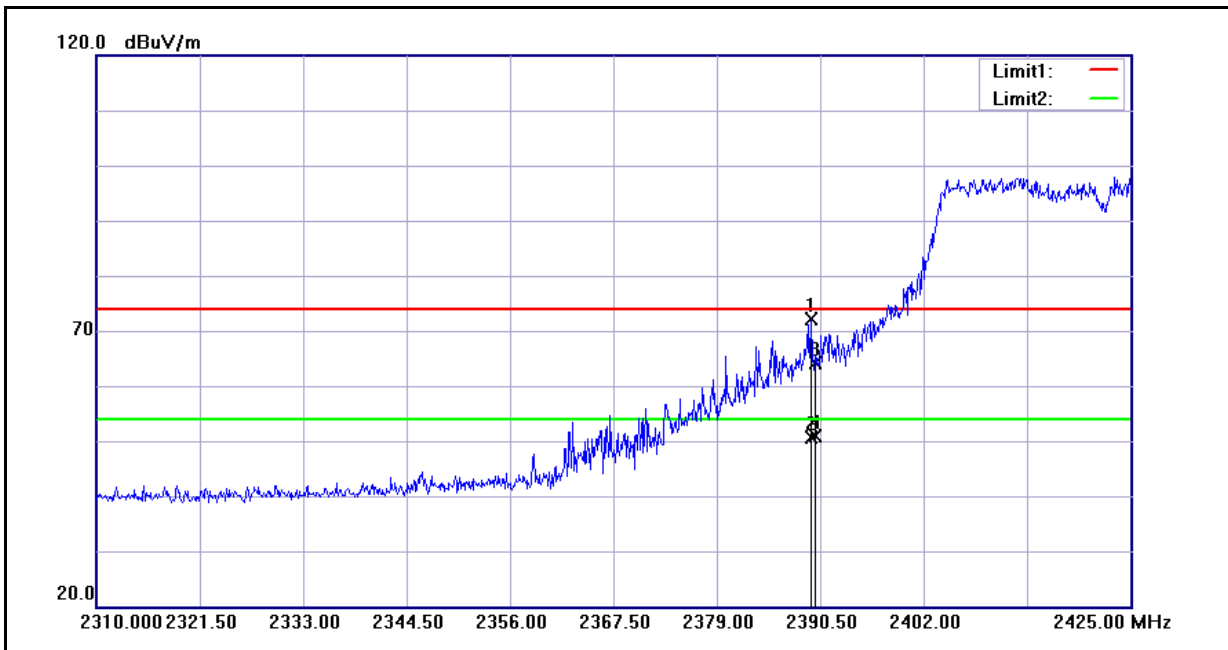

No.	Frequency (MHz)	Reading (dBuV)	Correct Factor(dB/m)	Result (dBuV/m)	Limit (dBuV/m)	Margin (dB)	Remark
1	2389.465	72.46	-0.22	72.24	74.00	-1.76	peak
2	2389.465	50.86	-0.22	50.64	54.00	-3.36	AVG
3	2390.000	64.32	-0.22	64.10	74.00	-9.90	peak
4	2390.000	51.08	-0.22	50.86	54.00	-3.14	AVG

Standard:	FCC Part 15C	Test Distance:	3m
Test item:	Radiated Emission	Power:	AC 120V/60Hz
Model Number:	AR5B97	Temp.(°C)/Hum.(%RH):	26(°C)/60%RH
Mode:	Mode 5	Date:	2011/03/30
Frequency:	2452 MHz	Test By:	Gary Wu
Ant.Polar.:	Horizontal		

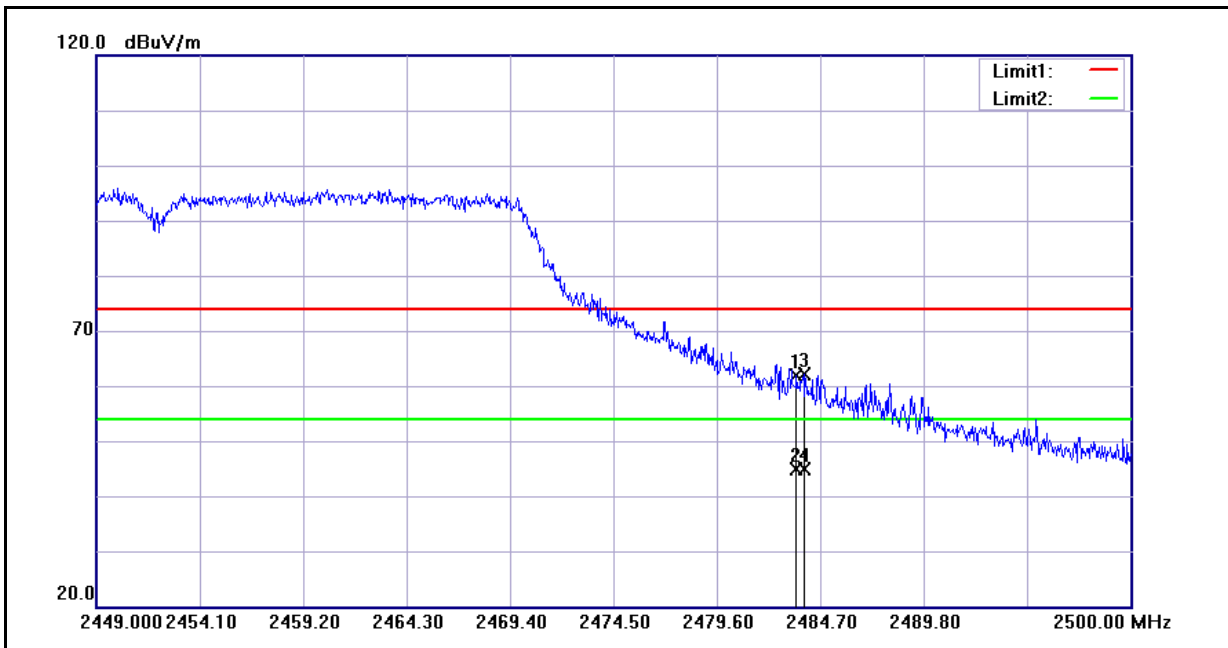

No.	Frequency (MHz)	Reading (dBuV)	Correct Factor(dB/m)	Result (dBuV/m)	Limit (dBuV/m)	Margin (dB)	Remark
1	2483.500	61.83	0.16	61.99	74.00	-12.01	peak
2	2483.500	44.79	0.16	44.95	54.00	-9.05	AVG
3	2483.884	61.88	0.16	62.04	74.00	-11.96	peak
4	2483.884	44.65	0.16	44.81	54.00	-9.19	AVG

Standard:	FCC Part 15C	Test Distance:	3m
Test item:	Radiated Emission	Power:	AC 120V/60Hz
Model Number:	AR5B97	Temp.(°C)/Hum.(%RH):	26(°C)/60%RH
Mode:	Mode 5	Date:	2011/03/30
Frequency:	2452 MHz	Test By:	Gary Wu
Ant.Polar.:	Vertical		

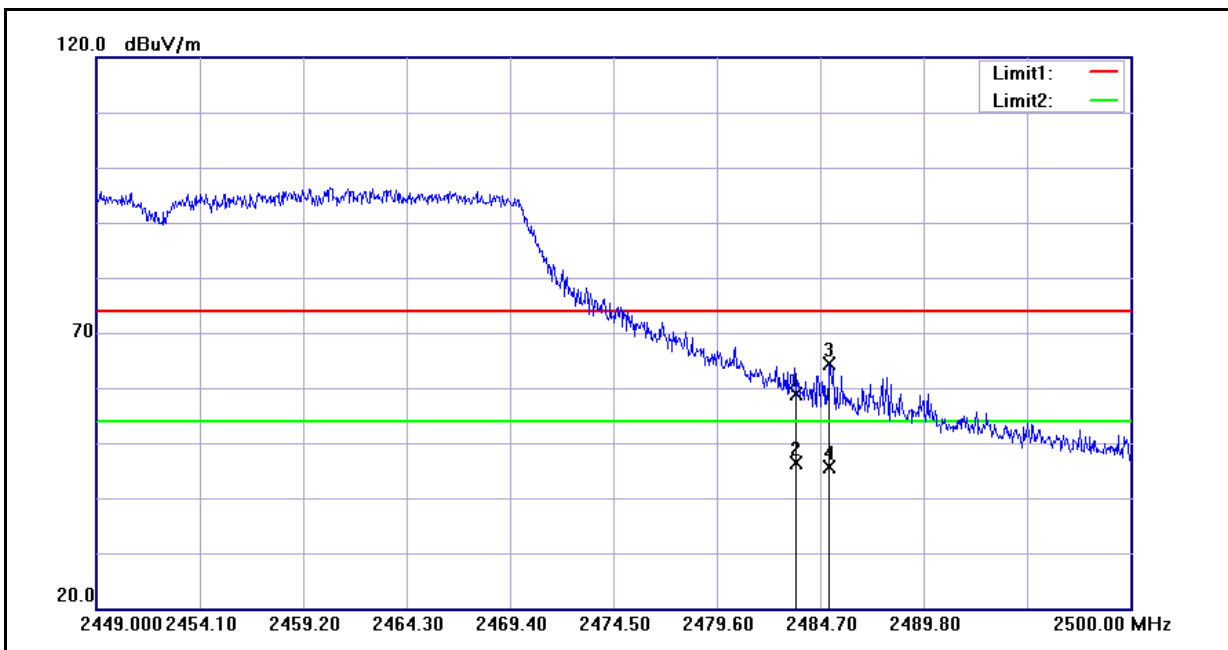

No.	Frequency (MHz)	Reading (dBuV)	Correct Factor(dB/m)	Result (dBuV/m)	Limit (dBuV/m)	Margin (dB)	Remark
1	2483.500	58.64	0.16	58.80	74.00	-15.20	peak
2	2483.500	46.10	0.16	46.26	54.00	-7.74	AVG
3	2485.159	64.14	0.16	64.30	74.00	-9.70	peak
4	2485.159	45.55	0.16	45.71	54.00	-8.29	AVG

7 Antenna Requirements

7.1. Limit

For intentional device, according to 15.203, an intentional radiator shall be designed to ensure that no antenna other than that furnished by the responsible party shall be used with the device.

And According to 15.247 (b), if transmitting antennas of directional gain greater than 6 dBi are used, the power shall be reduced by the amount in dB that the directional gain of the antenna exceeds 6dBi.

7.2. Antenna Connector Construction

The antenna used in this product is **PIFA antenna**. The gain of the main antenna is -1.45dBi and aux antenna is 0.24dBi.