

# TEST REPORT

**Product Name** : Rugged Tablet Computer  
**Model Number** : TB170  
**FCC ID** : HLETB170BTNL

**Prepared for** : Unitech Electronics Co., Ltd.  
**Address** : 5F, No. 136, Lane 235, Pao-Chiao Rd., Hsin-Tien Dist.,  
New Taipei City, Taiwan

**Prepared by** : EMTEK (SHENZHEN) CO., LTD.  
**Address** : Building 69, Majialong Industry Zone, Nanshan District,  
Shenzhen, Guangdong, China

Tel: (0755) 26954280  
Fax: (0755) 26954282

**Report Number** : ENS2205200174W00305R  
**Date(s) of Tests** : December 25, 2020 to March 26, 2021  
**Date of issue** : July 7, 2022

## TABLE OF CONTENTS

<b>1. TEST RESULT CERTIFICATION.....</b>	<b>3</b>
<b>2. EUT DESCRIPTION.....</b>	<b>4</b>
<b>3. SUMMARY OF TEST RESULT.....</b>	<b>6</b>
<b>4. TEST METHODOLOGY.....</b>	<b>7</b>
4.1 GENERAL DESCRIPTION OF APPLIED STANDARDS.....	7
4.2 MEASUREMENT EQUIPMENT USED.....	7
4.3 DESCRIPTION OF TEST MODES.....	8
<b>5. FACILITIES AND ACCREDITATIONS.....</b>	<b>11</b>
5.1 FACILITIES.....	11
5.2 EQUIPMENT.....	11
5.3 LABORATORY ACCREDITATIONS AND LISTINGS.....	11
<b>6. SETUP OF EQUIPMENT UNDER TEST.....</b>	<b>12</b>
6.1 SETUP CONFIGURATION OF EUT.....	12
6.2 CALIBRATION OF DFS DETECTION THRESHOLD LEVEL:.....	12
6.3 SUPPORT EQUIPMENT.....	13
<b>7. DYNAMIC FREQUENCY SELECTION REQUIREMENTS.....</b>	<b>14</b>
7.1 APPLICABLE STANDARD.....	14
7.2 CONFORMANCE LIMIT.....	14
7.3 TEST CONFIGURATION.....	14
7.4 TEST PARAMETERS OF DFS TEST SIGNAL.....	15
7.5 TRANSMITTER OUTPUT POWER.....	16
7.6 OPERATION MODES AND REQUIREMENT TEST ITEMS.....	17
7.7 TEST PROCEDURE.....	17
<b>8. TEST RESULT.....</b>	<b>18</b>
8.1 DETAILED TEST RESULTS.....	18
8.2 RADAR WAVEFORM.....	19
8.3 IN-SERVICE MONITORING.....	21

**1. TEST RESULT CERTIFICATION**

Applicant : Unitech Electronics Co., Ltd.  
 Address : 5F, No. 136, Lane 235, Pao-Chiao Rd., Hsin-Tien Dist., New Taipei City, Taiwan  
 Manufacturer : Unitech Electronics Co., Ltd.  
 Address : 5F, No. 136, Lane 235, Pao-Chiao Rd., Hsin-Tien Dist., New Taipei City, Taiwan  
 EUT : Rugged Tablet Computer  
 Model Name : TB170  
 Trademark : unitech

Measurement Procedure Used:

APPLICABLE STANDARDS	
STANDARD	TEST RESULT
FCC 06-96 FCC 47 CFR Part 15, Subpart E	PASS

The above equipment was tested by EMTEK(SHENZHEN) CO., LTD.. The test data, data evaluation, test procedures, and equipment configurations shown in this report were made in accordance with the procedures given in ANSI C63.10 (2013) and the energy emitted by the sample EUT tested as described in this report is in compliance with the requirements of FCC Rules Part 2 and Part 15.407.

The test results of this report relate only to the tested sample identified in this report.

Date of Test : December 25, 2020 to March 26, 2021

Prepared by : *Una Yu*  
 Una Yu/Editor

Reviewer : *Joe Xia*  
 Joe Xia/Supervisor

Approved & Authorized Signer : *Lisa Wang*  
 Lisa Wang/Manager



**2. EUT DESCRIPTION**

Characteristics	Description																																																						
Device style	5G WIFI (Slave equipment without radar detection function)																																																						
Model Number	TB170																																																						
IEEE 802.11 WLAN Mode Supported	<input checked="" type="checkbox"/> 802.11a(20MHz channel bandwidth) <input checked="" type="checkbox"/> 802.11n(20MHz channel bandwidth) <input checked="" type="checkbox"/> 802.11n(40MHz channel bandwidth) <input checked="" type="checkbox"/> 802.11ac(20MHz channel bandwidth) <input checked="" type="checkbox"/> 802.11ac(40MHz channel bandwidth) <input checked="" type="checkbox"/> 802.11ac(80MHz channel bandwidth) <input checked="" type="checkbox"/> 802.11ac(160MHz channel bandwidth)																																																						
Data Rate	WIFI: 802.11 a:6,9,12,18,24,36,48,54Mbps; 802.11n(HT20)/ac(HT20): MCS0-MCS15; 802.11n(HT40): MCS0-MCS15; 802.11ac(HT40):MCS0-MCS15; 802.11ac(VHT80):MCS0-MCS15; 802.11ac(VHT160):MCS0-MCS9;																																																						
Modulation	<input checked="" type="checkbox"/> OFDM with BPSK/QPSK/16QAM/64QAM for 802.11a/n; <input checked="" type="checkbox"/> OFDM with BPSK/QPSK/16QAM/64QAM/256QAM for 802.11ac;																																																						
Operating Frequency Rang	<table border="1"> <thead> <tr> <th>WIFI 5G Band</th> <th>Mode</th> <th>Frequency Range(MHz)</th> <th>Number of channels</th> </tr> </thead> <tbody> <tr> <td rowspan="4">UNII Band I</td> <td>802.11a/n(HT20)/ac(VHT20)</td> <td>5180-5240</td> <td>4</td> </tr> <tr> <td>802.11n(HT40)/ac(VHT40)</td> <td>5190-5230</td> <td>2</td> </tr> <tr> <td>802.11 ac(VHT80)</td> <td>5210</td> <td>1</td> </tr> <tr> <td>802.11 ac(VHT160)</td> <td>5250</td> <td>1</td> </tr> <tr> <td rowspan="3">UNII Band II-A</td> <td>802.11a/n(HT20)/ac(VHT20)</td> <td>5260-5320</td> <td>4</td> </tr> <tr> <td>802.11n(HT40)/ac(VHT40)</td> <td>5270-5310</td> <td>2</td> </tr> <tr> <td>802.11 ac(VHT80)</td> <td>5290</td> <td>1</td> </tr> <tr> <td rowspan="4">UNII Band II-C</td> <td>802.11a/n(HT20)/ac(VHT20)</td> <td>5500-5700</td> <td>11</td> </tr> <tr> <td>802.11n(HT40)/ac(VHT40)</td> <td>5510-5670</td> <td>5</td> </tr> <tr> <td>802.11 ac(VHT80)</td> <td>5530-5610</td> <td>2</td> </tr> <tr> <td>802.11 ac(VHT160)</td> <td>5570</td> <td>1</td> </tr> <tr> <td rowspan="3">UNII Band III</td> <td>802.11a/n(HT20)/ac(VHT20)</td> <td>5745-5825</td> <td>5</td> </tr> <tr> <td>802.11n(HT40)/ac(VHT40)</td> <td>5755-5795</td> <td>2</td> </tr> <tr> <td>802.11 ac(VHT80)</td> <td>5775</td> <td>1</td> </tr> <tr> <td colspan="4">For DFS frequency band: UNII Band II-A. UNII Band II-C</td> </tr> </tbody> </table>	WIFI 5G Band	Mode	Frequency Range(MHz)	Number of channels	UNII Band I	802.11a/n(HT20)/ac(VHT20)	5180-5240	4	802.11n(HT40)/ac(VHT40)	5190-5230	2	802.11 ac(VHT80)	5210	1	802.11 ac(VHT160)	5250	1	UNII Band II-A	802.11a/n(HT20)/ac(VHT20)	5260-5320	4	802.11n(HT40)/ac(VHT40)	5270-5310	2	802.11 ac(VHT80)	5290	1	UNII Band II-C	802.11a/n(HT20)/ac(VHT20)	5500-5700	11	802.11n(HT40)/ac(VHT40)	5510-5670	5	802.11 ac(VHT80)	5530-5610	2	802.11 ac(VHT160)	5570	1	UNII Band III	802.11a/n(HT20)/ac(VHT20)	5745-5825	5	802.11n(HT40)/ac(VHT40)	5755-5795	2	802.11 ac(VHT80)	5775	1	For DFS frequency band: UNII Band II-A. UNII Band II-C			
	WIFI 5G Band	Mode	Frequency Range(MHz)	Number of channels																																																			
	UNII Band I	802.11a/n(HT20)/ac(VHT20)	5180-5240	4																																																			
		802.11n(HT40)/ac(VHT40)	5190-5230	2																																																			
		802.11 ac(VHT80)	5210	1																																																			
		802.11 ac(VHT160)	5250	1																																																			
	UNII Band II-A	802.11a/n(HT20)/ac(VHT20)	5260-5320	4																																																			
		802.11n(HT40)/ac(VHT40)	5270-5310	2																																																			
		802.11 ac(VHT80)	5290	1																																																			
	UNII Band II-C	802.11a/n(HT20)/ac(VHT20)	5500-5700	11																																																			
		802.11n(HT40)/ac(VHT40)	5510-5670	5																																																			
		802.11 ac(VHT80)	5530-5610	2																																																			
		802.11 ac(VHT160)	5570	1																																																			
	UNII Band III	802.11a/n(HT20)/ac(VHT20)	5745-5825	5																																																			
802.11n(HT40)/ac(VHT40)		5755-5795	2																																																				
802.11 ac(VHT80)		5775	1																																																				
For DFS frequency band: UNII Band II-A. UNII Band II-C																																																							
Antenna Type	PIFA antenna																																																						
Smart system	<input checked="" type="checkbox"/> SISO <span style="margin-left: 200px;"><input checked="" type="checkbox"/> MIMO</span>																																																						
Antenna Gain	Main(Antenna 1)	AUX(Antenna 2)																																																					
	5150-5350: 3.4 dBi 5500-5700: 3.8 dBi	5150-5350: 2.0 dBi 5500-5700: 4.9 dBi																																																					

	5725-5825: 3.8 dBi	5725-5825: 4.9 dBi
<b>Direction Gain</b>	5150-5350: 5.77 dBi 5500-5700: 7.40 dBi 5725-5825: 7.40 dBi	
<b>Power Supply</b>	Battery: DC 7.6V internal rechargeable li-ion polymer battery Model: IP575399-2S Rating: DC 7.6V, 4800mAh, 36.5Wh Adapter 1: Model: ADP-65JH HB INPUT: 100-240V~1.5A 50-60Hz OUTPUT: DC 19V, 3.42A Adapter 2: Model: A18-065N3A INPUT: 100-240V~1.7A 50-60Hz OUTPUT: DC 19V, 3.42A, 65W	
<b>Temperature Range</b>	-20°C ~ +60°C	

**Note:** for more details, please refer to the user's manual of the EUT.

### 3. SUMMARY OF TEST RESULT

FCC Part Clause	Test Parameter	Verdict	Remark
15.407 (h) (i) (j)	Dynamic Frequency Selection	PASS	
<p>NOTE1: N/A (Not Applicable)</p> <p>NOTE2: According to FCC OET KDB 905462 D02 UNII DFS Compliance Procedures New Rules v02, In addition, the radiated test is also performed to ensure the emissions emanating from the device cabinet also comply with the applicable limits.</p> <p>NOTE3: This report only add adapter2 information and update model name, trademark, applicant and manufacturer information, all test data refer to report No. ES201225029W05.</p>			



#### 4. TEST METHODOLOGY

##### 4.1 GENERAL DESCRIPTION OF APPLIED STANDARDS

According to its specifications, the EUT must comply with the requirements of the following standards:

FCC 06-96

FCC 47 CFR Part 15, Subpart E

FCC KDB 905462 D02 UNII DFS Compliance Procedures New Rules v02

##### 4.2 MEASUREMENT EQUIPMENT USED

###### For Spurious Emissions Test

Equipment	Manufacturer	Model No.	Serial No.	Last Cal.	Cal. Interval
EMI Test Receiver	Rohde & Schwarz	ESU 26	100154	May 17, 2020	1 Year
Pre-Amplifie	Lunar EM	LNA30M3G-25	J10100000070	May 17, 2020	1 Year
Bilog Antenna	Schwarzbeck	VULB9163	659	Sep 22, 2019	2 Year
Horn antenna	Schwarzbeck	BBHA9120D	9120D-1177	May 17, 2020	2 Year
Pre-Amplifie	SKET	LNPA_0118G-45	SK2019051801	May 17, 2020	1 Year
Loop Antenna	Schwarzbeck	FMZB1519	1519-012	July 14, 2019	2 Year
Spectrum Analyzer	Rohde & Schwarz	FSV40	100967	May 17, 2020	1 Year
Horn antenna	Schwarzbeck	BBHA9120D	9120D-1198	May 17, 2020	2 Year
Bilog Antenna	Schwarzbeck	VULB9163	660	July 16, 2019	2 Year
Cable	H+B	NmSm-05-C15052	N/A	May 17, 2020	1 Year
Cable	H+B	NmSm-2-C15201	N/A	May 17, 2020	1 Year
Cable	H+B	NmNm-7-C15702	N/A	May 17, 2020	1 Year
Cable	H+B	SAC-40G-1	414	May 17, 2020	1 Year
Cable	H+B	SUCOFLEX104	MY14871/4	May 17, 2020	
Cable	H+B	BLU18A-NmSm-6500	D8501	May 17, 2020	1 Year
Band reject Filter(50dB)	WI/DE	WRCGV-2400(2400-2485MHz)	2	May 17, 2020	1 Year

###### For other test items:

Equipment	Manufacturer	Model No.	Serial No.	Last Cal.	Cal. Interval
Vector Signal Generater	Agilent	N5182B	My53050553	May 17, 2020	1 Year
Analog Signal Generator	Agilent	N5171B	My53050878	May 17, 2020	1 Year
Signal Analyzer	Agilent	N9010A	My53470879	May 17, 2020	1 Year
Power Analyzer	Agilent	PS-X10-200	N/A	May 17, 2020	1 Year
Wideband Radio Communication Tester	R&S	CMW500	1201.0002K50-140822zk	May 17, 2020	1 Year
Test Accessories	Agilent	PS-X10-100	N/A	May 17, 2020	1 Year
Temperature&Humidity test chamber	ESPEC	EL-02KA	12107166	May 17, 2020	1 Year
Blocking Box	Agilent	AD211	N/A	May 17, 2020	1 Year

### 4.3 DESCRIPTION OF TEST MODES

The EUT has been tested under its typical operating condition.

The EUT configuration for testing is installed on RF field strength measurement to meet the Commissions requirement and operating in a manner which intends to maximize its emission characteristics in a continuous normal application.

The Transmitter was operated in the normal operating mode. The TX frequency was fixed which was for the purpose of the measurements.

Test of channel included the lowest and middle and highest frequency to perform the test, then record on this report.

Those data rates ( 802.11a: 6 Mbps;  802.11n (HT20): MCS0;  802.11n (HT20): MCS7;  802.11n (HT40): MCS0;  802.11n (HT40): MCS7;  802.11ac (HT20): MCS0;  802.11ac (HT20): MCS7;  802.11ac (HT40): MCS0;  802.11ac (HT40): MCS7;  802.11ac (HT80): MCS0;  802.11ac (HT80): MCS7,  802.11ac (HT160): MCS9) were used for all test.

Pre-defined engineering program for regulatory testing used to control the EUT for staying in continuous transmitting and receiving mode is programmed.





Wifi 5G with U-NII -2A

Frequency and Channel list for 802.11a/n (HT20)/802.11ac (HT20):

Channel	Frequency (MHz)	Channel	Frequency (MHz)	Channel	Frequency (MHz)
52	5260	60	5300		
56	5280	64	5320		

Frequency and Channel list for 802.11n (HT40)/ 802.11ac (HT40):

Channel	Frequency (MHz)	Channel	Frequency (MHz)	Channel	Frequency (MHz)
54	5270				
62	5310				

Frequency and Channel list for 802.11ac (HT80):

Channel	Frequency (MHz)	Channel	Frequency (MHz)	Channel	Frequency (MHz)
58	5290				

Test Frequency and Channel for 802.11a/n (HT20)/802.11ac (HT20):

Lowest Frequency		Middle Frequency		Highest Frequency	
Channel	Frequency (MHz)	Channel	Frequency (MHz)	Channel	Frequency (MHz)
52	5260	56	5280	64	5320

Test Frequency and channel for 802.11n (HT40)/ 802.11ac (HT40):

Lowest Frequency		Middle Frequency		Highest Frequency	
Channel	Frequency (MHz)	Channel	Frequency (MHz)	Channel	Frequency (MHz)
54	5270	N/A	N/A	62	5310

Test Frequency and channel for 802.11ac (HT80):

Lowest Frequency		Middle Frequency		Highest Frequency	
Channel	Frequency (MHz)	Channel	Frequency (MHz)	Channel	Frequency (MHz)
58	5290				

Wifi 5G with U-NII -2C

Frequency and Channel list for 802.11a/n (HT20)/802.11ac (HT20):

Channel	Frequency (MHz)	Channel	Frequency (MHz)	Channel	Frequency (MHz)
100	5500	116	5580	132	5660
104	5520	120	5600	136	5680
108	5540	124	5620	140	5700
112	5560	128	5640		

Frequency and Channel list for 802.11n (HT40)/ 802.11ac (HT40):

Channel	Frequency (MHz)	Channel	Frequency (MHz)	Channel	Frequency (MHz)
102	5510	118	5590	134	5670
110	5550	126	5630		

Frequency and Channel list for 802.11ac (HT80):

Channel	Frequency (MHz)	Channel	Frequency (MHz)	Channel	Frequency (MHz)
106	5530	122	5610		

Frequency and Channel list for 802.11ac (HT160):

Channel	Frequency (MHz)	Channel	Frequency (MHz)	Channel	Frequency (MHz)
114	5570				

**Test** Frequency and Channel for 802.11a/n (HT20)/802.11ac (HT20):

Lowest Frequency		Middle Frequency		Highest Frequency	
Channel	Frequency (MHz)	Channel	Frequency (MHz)	Channel	Frequency (MHz)
100	5500	116	5580	140	5700

**Test** Frequency and channel for 802.11n (HT40)/ 802.11ac (HT40):

Lowest Frequency		Middle Frequency		Highest Frequency	
Channel	Frequency (MHz)	Channel	Frequency (MHz)	Channel	Frequency (MHz)
102	5510			134	5670

**Test** Frequency and channel for 802.11ac (HT80):

Lowest Frequency		Middle Frequency		Highest Frequency	
Channel	Frequency (MHz)	Channel	Frequency (MHz)	Channel	Frequency (MHz)
106	5530				

**Test** Frequency and channel for 802.11ac (HT160):

Lowest Frequency		Middle Frequency		Highest Frequency	
Channel	Frequency (MHz)	Channel	Frequency (MHz)	Channel	Frequency (MHz)
114	5570				

## 5. FACILITIES AND ACCREDITATIONS

### 5.1 FACILITIES

All measurement facilities used to collect the measurement data are located at

Bldg 69, Majialong Industry Zone District, Nanshan District, Shenzhen, China

The sites are constructed in conformance with the requirements of ANSI C63.7, ANSI C63.4 and CISPR Publication 22.

### 5.2 EQUIPMENT

Radiated emissions are measured with one or more of the following types of linearly polarized antennas: tuned dipole, biconical, log periodic, bi-log, and/or ridged waveguide, horn. Spectrum analyzers with preselectors and quasi-peak detectors are used to perform radiated measurements.

Conducted emissions are measured with Line Impedance Stabilization Networks and EMI Test Receivers.

Calibrated wideband preamplifiers, coaxial cables, and coaxial attenuators are also used for making measurements.

All receiving equipment conforms to CISPR Publication 16-1, "Radio Interference Measuring Apparatus and Measurement Methods."

### 5.3 LABORATORY ACCREDITATIONS AND LISTINGS

Site Description  
EMC Lab.

: **Accredited by CNAS**  
The Certificate Registration Number is L2291  
The Laboratory has been assessed and proved to be in compliance with  
CNAS-CL01 (identical to ISO/IEC 17025:2017)

**Accredited by FCC**  
Designation Number: CN1204  
Test Firm Registration Number: 882943

**Accredited by A2LA**  
The Certificate Number is 4321.01

**Accredited by Industry Canada**  
The Conformity Assessment Body Identifier is CN0008

Name of Firm : EMTEK (SHENZHEN) CO., LTD.  
Site Location : Building 69, Majialong Industry Zone, Nanshan District, Shenzhen,  
Guangdong, China

## 6. SETUP OF EQUIPMENT UNDER TEST

### 6.1 SETUP CONFIGURATION OF EUT

#### Master Modes

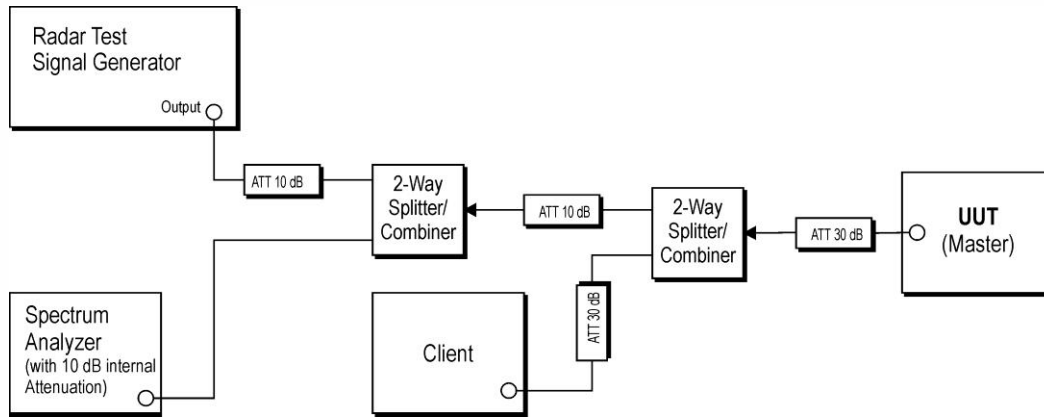

#### Slave Mode

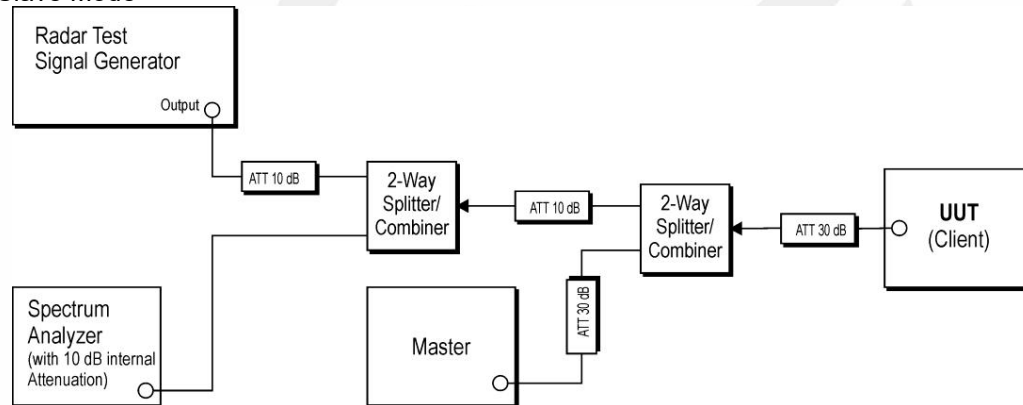

### 6.2 CALIBRATION OF DFS DETECTION THRESHOLD LEVEL:

A 50 ohm load is connected in place of the spectrum analyzer, and the spectrum analyzer is connected in place of the master device and the signal generator is set to CW mode. The amplitude of the signal generator is adjusted to yield a level of  $-62$  dBm as measured on the spectrum analyzer. Without changing any of the instrument settings, the spectrum analyzer is reconnected to the Common port of the Spectrum Analyzer Combiner/Divider. Measure the amplitude and calculate the difference from  $-62$  dBm. Adjust the Reference Level Offset of the spectrum analyzer to this difference. The spectrum analyzer displays the level of the signal generator as received at the antenna ports of the Master Device. The interference detection threshold may be varied from the calibrated value of  $-62$  dBm and the spectrum analyzer will still indicate the level as received by the Master Device. Set the signal generator to produce a radar waveform, trigger a burst manually and measure the level on the spectrum analyzer. Readjust the amplitude of the signal generator as required so that the peak level of the waveform is at a displayed level equal to the required or desired interference detection threshold. Separate signal generator amplitude settings are determined as required for each radar type.

### 6.3 SUPPORT EQUIPMENT

Item	Equipment	Mfr/Brand	Model/Type No.	Series No.	Note
1.	Wireless Access Point	Cisco	AIR-CAP3702E-A-K9	FTX182276QD	FCC ID: LDK102087 IC:2461B-102087
Note: Software for transferring data between master and slave devices is TFGEN-1.00					

**Notes:**

1. All the equipment/cables were placed in the worst-case configuration to maximize the emission during the test.
2. Grounding was established in accordance with the manufacturer's requirements and conditions for the intended use.



## 7. DYNAMIC FREQUENCY SELECTION REQUIREMENTS

### 7.1 APPLICABLE STANDARD

According to 15.407

### 7.2 CONFORMANCE LIMIT

The dynamic frequency selection requirement

Parameter	Value
Non-occupancy period	Minimum 30 minutes
Channel Availability Check Time	60 seconds
Channel Move Time	10 seconds See Note 1.
Channel Closing Transmission Time	200 milliseconds + an aggregate of 60 milliseconds over remaining 10 second period. See Notes 1 and 2.
U-NII Detection Bandwidth	Minimum 100% of the U-NII 99% transmission power bandwidth. See Note 3.
<p><b>Note 1:</b> <i>Channel Move Time</i> and the <i>Channel Closing Transmission Time</i> should be performed with Radar Type 0. The measurement timing begins at the end of the Radar Type 0 burst.</p> <p><b>Note 2:</b> The <i>Channel Closing Transmission Time</i> is comprised of 200 milliseconds starting at the beginning of the <i>Channel Move Time</i> plus any additional intermittent control signals required to facilitate a <i>Channel</i> move (an aggregate of 60 milliseconds) during the remainder of the 10 second period. The aggregate duration of control signals will not count quiet periods in between transmissions.</p> <p><b>Note 3:</b> During the <i>U-NII Detection Bandwidth</i> detection test, radar type 0 should be used. For each frequency step the minimum percentage of detection is 90 percent. Measurements are performed with no data traffic.</p>	

The following table lists the DFS The detection threshold values

Maximum Transmit Power	Value (See Notes 1, 2, and 3)
EIRP $\geq$ 200 milliwatt	-64 dBm
EIRP < 200 milliwatt and power spectral density < 10 dBm/MHz	-62 dBm
EIRP < 200 milliwatt that do not meet the power spectral density requirement	-64 dBm
<p><b>Note 1:</b> This is the level at the input of the receiver assuming a 0 dBi receive antenna.</p> <p><b>Note 2:</b> Throughout these test procedures an additional 1 dB has been added to the amplitude of the test transmission waveforms to account for variations in measurement equipment. This will ensure that the test signal is at or above the detection threshold level to trigger a DFS response.</p> <p><b>Note3:</b> EIRP is based on the highest antenna gain. For MIMO devices refer to KDB Publication 662911 D01.</p>	

### 7.3 TEST CONFIGURATION

Conducted measurements shall be used for DFS test

## 7.4 TEST PARAMETERS OF DFS TEST SIGNAL

The following table lists the parameters of radar test signals

### Short Pulse Radar Test Waveforms

Radar Type	Pulse Width (μsec)	PRI (μsec)	Number of Pulses	Minimum Percentage of Successful Detection	Minimum Number of Trials
0	1	1428	18	See Note 1	See Note 1
1	1	Test A: 15 unique PRI values randomly selected from the list of 23 PRI values in Table 5a	Roundup $\left\{ \begin{array}{l} \left( \frac{1}{360} \right) \cdot \\ \left( \frac{19 \cdot 10^6}{\text{PRI}_{\mu\text{sec}}} \right) \end{array} \right\}$	60%	30
		Test B: 15 unique PRI values randomly selected within the range of 518-3066 μsec, with a minimum increment of 1 μsec, excluding PRI values selected in Test A			
2	1-5	150-230	23-29	60%	30
3	6-10	200-500	16-18	60%	30
4	11-20	200-500	12-16	60%	30
Aggregate (Radar Types 1-4)				80%	120
<b>Note 1:</b> Short Pulse Radar Type 0 should be used for the detection bandwidth test, channel move time, and channel closing time tests.					

### Long Pulse Radar Test Waveform

Radar Type	Pulse Width (μsec)	Chirp Width (MHz)	PRI (μsec)	Number of Pulses per Burst	Number of Bursts	Minimum Percentage of Successful Detection	Minimum Number of Trials
5	50-100	5-20	1000-2000	1-3	8-20	80%	30

### Frequency Hopping Radar Test Waveform

Radar Type	Pulse Width (μsec)	PRI (μsec)	Pulses per Hop	Hopping Rate (kHz)	Hopping Sequence Length (msec)	Minimum Percentage of Successful Detection	Minimum Number of Trials
6	1	333	9	0.333	300	70%	30

**7.5 TRANSMITTER OUTPUT POWER**

25°C

**Humidity:**

55 % RH

Band	Max Power	
	Conducted Output Power	E.I.R.P
5250MHz-5350MHz	16.29dBm(42.56mW)	22.06dBm(160.69mW)
5470MHz-5725MHz	17.16dBm(52.00mW)	24.56dBm(285.76mW)





### 7.6 OPERATION MODES AND REQUIREMENT TEST ITEMS

The manufacture shall state whether the EUT is capable of operating as a Master or a Slave modes,if the EUT is capable of operating in more than one operational mode then every operating mode shall be assessed separately.

Applicability of DFS Requirements Prior to Use of a Channel

Requirement	Operational Mode		
	Master	Client Without Radar Detection	Client With Radar Detection
Non-Occupancy Period	Yes	Not required	Yes
DFS Detection Threshold	Yes	Not required	Yes
Channel Availability Check Time	Yes	Not required	Not required
Uniform Spreading	Yes	Not required	Not required
U-NII Detection Bandwidth	Yes	Not required	Yes

Applicability of DFS requirements during normal operation

Requirement	Operational Mode		
	Master	Client Without Radar Detection	Client With Radar Detection
DFS Detection Threshold	Yes	Not required	Yes
Channel Closing Transmission Time	Yes	Yes	Yes
Channel Move Time	Yes	Yes	Yes
U-NII Detection Bandwidth	Yes	Not required	Yes

### 7.7 TEST PROCEDURE

According to KDB 905462 D02v02 Section 7.

## 8. TEST RESULT

### 8.1 DETAILED TEST RESULTS

Clause	MODES	Test Parameter	Remark	Verdict
15.407	<input type="checkbox"/> Master	DFS Detection Threshold	N/A	N/A
15.407		Channel Availability Check Time	N/A	N/A
15.407		Channel Move Time	N/A	N/A
15.407		Channel Closing Transmission Time	N/A	N/A
15.407		Non-Occupancy Period	N/A	N/A
15.407		Uniform Spreading	N/A	N/A
15.407		U-NII Detection Bandwidth	N/A	N/A
15.407	<input checked="" type="checkbox"/> Slave	Radar Detection Threshold	N/A	N/A
15.407		Channel Move Time	Applicable	PASS
15.407		Channel Closing Transmission Time	Applicable	PASS
15.407		Non-Occupancy Period	N/A	N/A
15.407		U-NII Detection Bandwidth	N/A	N/A

## 8.2 RADAR WAVEFORM

Calibration:

Maximum Transmit Power is 200 mW to 1 W in this report, so detection threshold level is -64dBm.

The 801.11a/n/ac have been tested, and the worst result have been recorded in the below page.



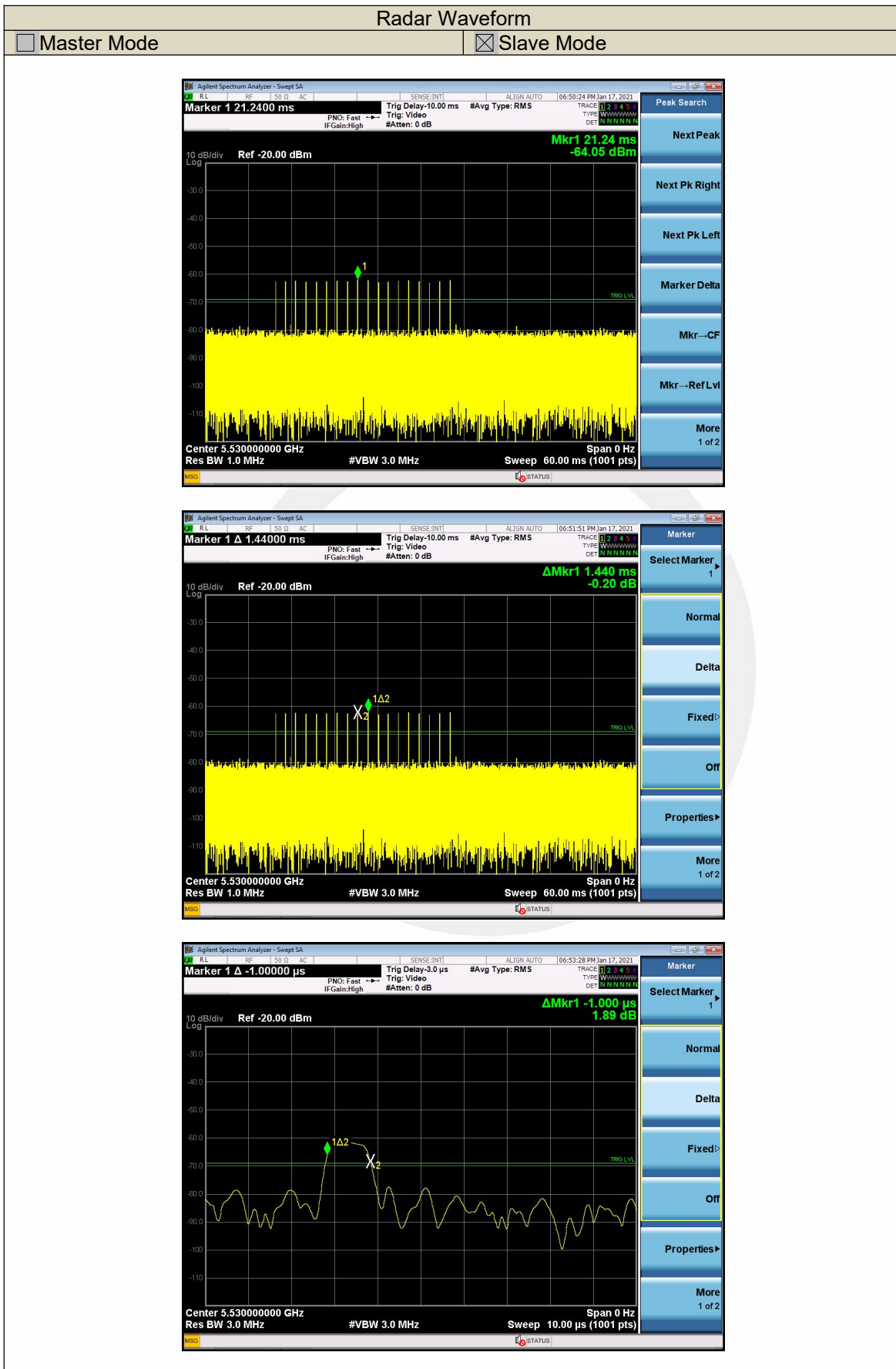

### 8.3 IN-SERVICE MONITORING

UNII Band II-A

Radar test signal type 0					Detection(Y/N)
Trial ID	Pulse Width(us)	PRI(us)	Number of Pulses	Waveform Length(us)	
0	1.0	1428.0	18	25704.0	Y
1	1.0	1428.0	18	25704.0	Y
2	1.0	1428.0	18	25704.0	Y
3	1.0	1428.0	18	25704.0	Y
4	1.0	1428.0	18	25704.0	Y
5	1.0	1428.0	18	25704.0	Y
6	1.0	1428.0	18	25704.0	Y
7	1.0	1428.0	18	25704.0	Y
8	1.0	1428.0	18	25704.0	Y
9	1.0	1428.0	18	25704.0	Y
10	1.0	1428.0	18	25704.0	Y
11	1.0	1428.0	18	25704.0	Y
12	1.0	1428.0	18	25704.0	Y
13	1.0	1428.0	18	25704.0	Y
14	1.0	1428.0	18	25704.0	Y
15	1.0	1428.0	18	25704.0	N
16	1.0	1428.0	18	25704.0	Y
17	1.0	1428.0	18	25704.0	Y
18	1.0	1428.0	18	25704.0	N
19	1.0	1428.0	18	25704.0	Y
20	1.0	1428.0	18	25704.0	N
21	1.0	1428.0	18	25704.0	Y
22	1.0	1428.0	18	25704.0	Y
23	1.0	1428.0	18	25704.0	Y
24	1.0	1428.0	18	25704.0	Y
25	1.0	1428.0	18	25704.0	Y
26	1.0	1428.0	18	25704.0	Y
27	1.0	1428.0	18	25704.0	Y
28	1.0	1428.0	18	25704.0	Y
29	1.0	1428.0	18	25704.0	Y
<b>Detection Rate</b>					<b>90%</b>

## UNII Band II-C

Radar test singal type 0					Detection(Y/N)
Trial ID	Pulse Width(us)	PRI(us)	Number of Pulses	Waveform Length(us)	
0	1.0	1428.0	18	25704.0	Y
1	1.0	1428.0	18	25704.0	Y
2	1.0	1428.0	18	25704.0	Y
3	1.0	1428.0	18	25704.0	Y
4	1.0	1428.0	18	25704.0	Y
5	1.0	1428.0	18	25704.0	Y
6	1.0	1428.0	18	25704.0	Y
7	1.0	1428.0	18	25704.0	Y
8	1.0	1428.0	18	25704.0	Y
9	1.0	1428.0	18	25704.0	Y
10	1.0	1428.0	18	25704.0	Y
11	1.0	1428.0	18	25704.0	Y
12	1.0	1428.0	18	25704.0	Y
13	1.0	1428.0	18	25704.0	Y
14	1.0	1428.0	18	25704.0	Y
15	1.0	1428.0	18	25704.0	Y
16	1.0	1428.0	18	25704.0	N
17	1.0	1428.0	18	25704.0	Y
18	1.0	1428.0	18	25704.0	Y
19	1.0	1428.0	18	25704.0	Y
20	1.0	1428.0	18	25704.0	Y
21	1.0	1428.0	18	25704.0	Y
22	1.0	1428.0	18	25704.0	Y
23	1.0	1428.0	18	25704.0	Y
24	1.0	1428.0	18	25704.0	Y
25	1.0	1428.0	18	25704.0	Y
26	1.0	1428.0	18	25704.0	Y
27	1.0	1428.0	18	25704.0	N
28	1.0	1428.0	18	25704.0	Y
29	1.0	1428.0	18	25704.0	Y
<b>Detection Rate</b>					<b>93.3%</b>

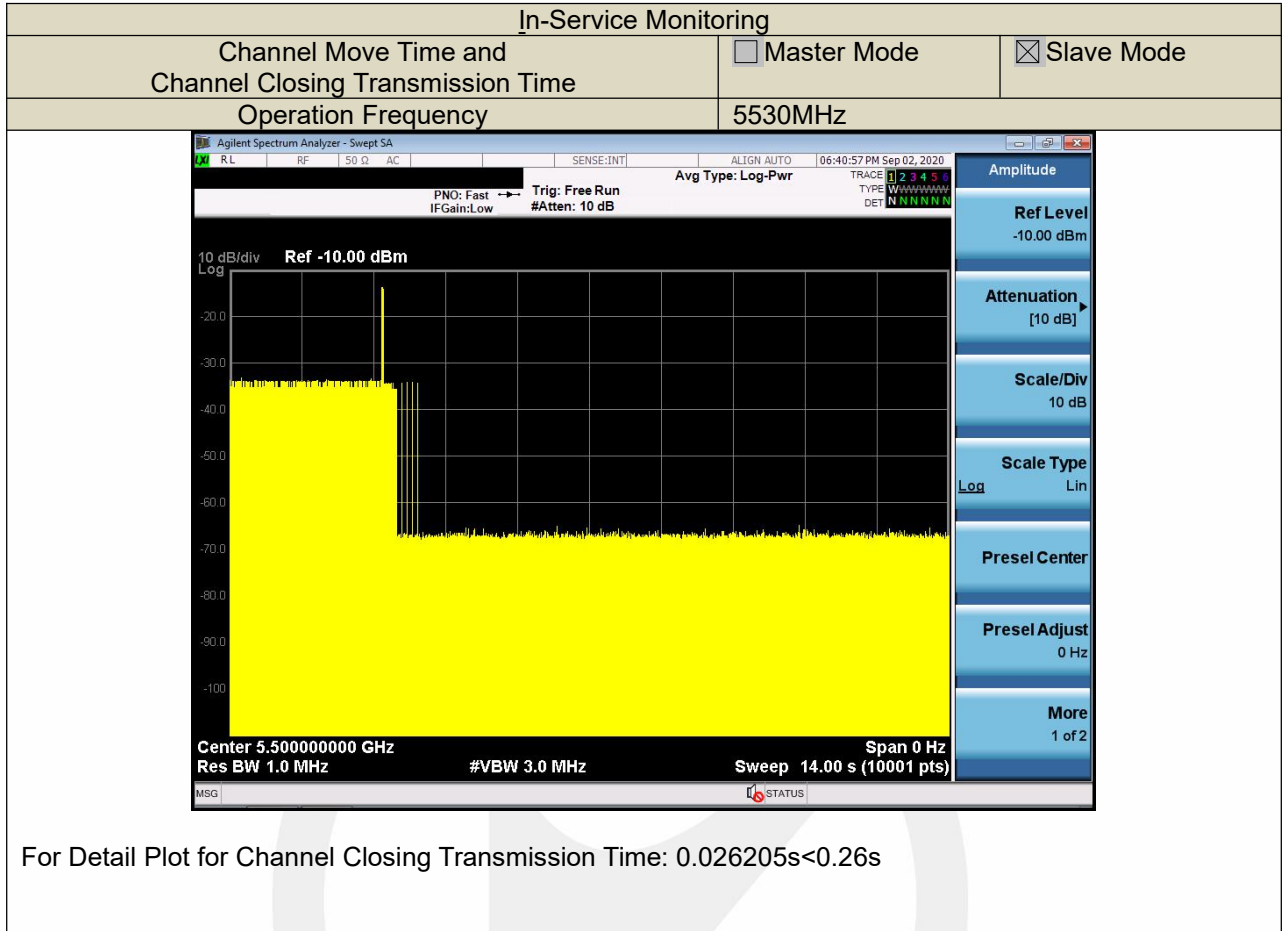

--- End of Report ---