

A Versatile Multi-Function Terminal

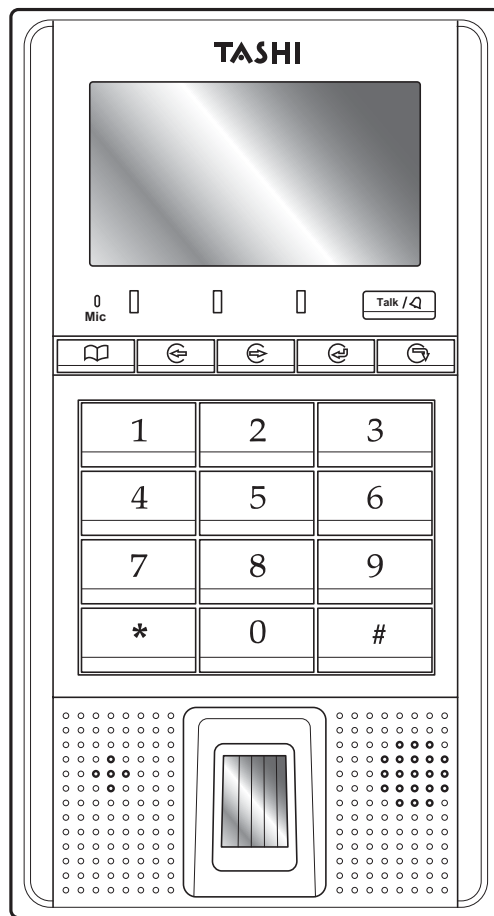

User Manual

400664G Version 3.0



About This Manual

This manual explains how to install, operate and maintain MT180 IP-based Access Control Terminal.

No part of this publication may be reproduced or used in any form, or by any electrical or mechanical means, without permission in writing from the manufacturer, which includes but is not limited to photocopying, recording, or information storage and retrieval systems. The material in this manual is subject to change without notice.

© Copyright 2009 Unitech Electronics Co., Ltd. All rights reserved.

Unitech TASHI Website: <http://www.unitech-sbd.com>

Unitech Global Website: <http://www.unitech-adc.com>

Regulatory Compliance Statements

FCC Warning Statement

This equipment has been tested and found to comply with the limits for a Class B digital device, pursuant to part 15 of the FCC rules. These limits are designed to provide reasonable protection against harmful interference in a residential installation.

This equipment generates, uses and can radiate radio frequency energy and, if not installed and used in accordance with the instructions, may cause harmful interference to radio communications. However, there is no guarantee that interference will not occur in a particular installation. If this equipment does cause harmful interference to radio or television reception, which can be determined by turning the equipment off and on, the user is encouraged to try to correct the interference by one or more of the following measures:

- Reorient or relocate the receiving antenna.
- Increase the separation between the equipment and receiver.
- Connect the equipment into an outlet on a circuit different from that to which the receiver is connected.
- Consult the dealer or an experienced radio/TV technician for help.

Any changes or modifications (including the antennas) made to this device that are not expressly approved by the manufacturer may void the user's authority to operate the equipment.

Canadian Compliance Statement

Industry Canada Notice Operation is subject to the following two conditions: (1) This device may not cause interference and (2) This device must accept any interference, including interference that may cause undesired operation of the device.

European Conformity Statement

Declaration of Conformity with Regard to the R&TTE 1999/5/EC and EMC 89/336/ EEC directives.

RoHS Statement



This device conforms to RoHS (Restriction of Hazardous Substances) European Union regulations that set maximum concentration limits on hazardous materials used in electrical and electronic equipment.

Taiwan NCC Warning Statement

根據 NCC 低功率電波輻射性電機管理辦法 規定：

第十二條 經型式認證合格之低功率射頻電機，非經許可，公司、商號或使用者均不得擅自變更頻率、加大功率或變更原設計之特性及功能。

第十四條 低功率射頻電機之使用不得影響飛航安全及干擾合法通信；經發現有干擾現象時，應立即停用，並改善至無干擾時方得繼續使用。

前項合法通信，指依電信法規定作業之無線電通信。低功率射頻電機須忍受合法通信或工業、科學及醫療用電波輻射性電機設備之干擾。



Warranty

Under Unitech limited Warranty, the following items are covered:

- MT180 IP-based Access Control Terminal - 1-year limited warranty.
- Cables - three month limited warranty.

Table of Contents

Preface

About This Manual	i
Regulatory Compliance Statements	i
FCC Warning Statement	i
Canadian Compliance Statement.....	ii
European Conformity Statement.....	ii
RoHS Statement.....	ii
Taiwan NCC Warning Statement	ii
Warranty	ii

Chapter 1

Getting Started	1
Introducing MT180.....	1
Features	1
Setting up MT180	2
Connecting Power	2
Identifying LED Indicator Lights.....	2
Establishing Terminal-PC Connection.....	3
Setting Date and Time.....	4
Utilizing Software.....	4

Chapter 2

Using the Hardware	5
Using the Keypad	5
Using Proximity Reader.....	6
Using Fingerprint Reader.....	8
Using DECT Phone (Optional).....	11

Chapter 3

Onscreen Setting	12
General Settings.....	12
Advanced Settings.....	13

Chapter 4

Advanced Setting	15
Shift Attendance	15
Scenario I - Swipe Card to Clock In.....	25
Security Operation	26
Scenario I - Place Security Ban.....	33
Scenario II - Lift Security Ban.....	33
Scenario III - Trigger Security Alarm	34
Anti-Pass Back Setting	34
Scenario I - Normal Entrance and Exit.....	43
Scenario II - Re-Entering.....	43
Scenario III - Re-Exiting.....	43

Appendix A

System Specification	45
----------------------------	----

Appendix B

Worldwide Support..... 46

Getting Started

Introducing MT180

MT180 is a TASHI (Time & Attendance, Access Control, Security, Home Automation and Intercom) terminal. It communicates with a central host security and T&A system through a standard Ethernet network. The built-in proximity and fingerprint readers provide strict access control to a secure area. Thanks for purchasing one of the most compact and cost-efficient access control and time and attendance management solutions on the market.

Features

Powerful System

- 72 Mhz ARM7TDMI-S.

System Memory

- 8 MB Flash ROM.

Display

- COG/FSTN LCD with White Backlight.
- 128 x 64 Pixel Resolution.

User Interface

- 18 Hard Keys.
- LED Indicators (3).

Fingerprint Reader

- Fingerprint Capacity: 7,000.

Proximity Reader

- Card Capacity: 40,960.
- Supports reader types:
 - EM, 125kHz.
 - HID, 125kHz.
 - MiFare, 13.56MHz.

Communication

- Ethernet 10/100M.
- RS485.
- Digital Inputs (3).
- Relay (2).
- DECT Voice (Optional).

I/O Expansion

- RS232 Drive (Secondary Reader).
- Digital Inputs (3).
- Digital Outputs (3).

Software Tools

- JanitorLite.
- MTTool.
- Communication Software Development Kit.

Setting up MT180

Connecting Power

Connect power to MT180 through the following:

1. Connect the AC Adapter into MT180's DC Connector Port (1). Plug the AC Adapter into an electrical outlet (2).

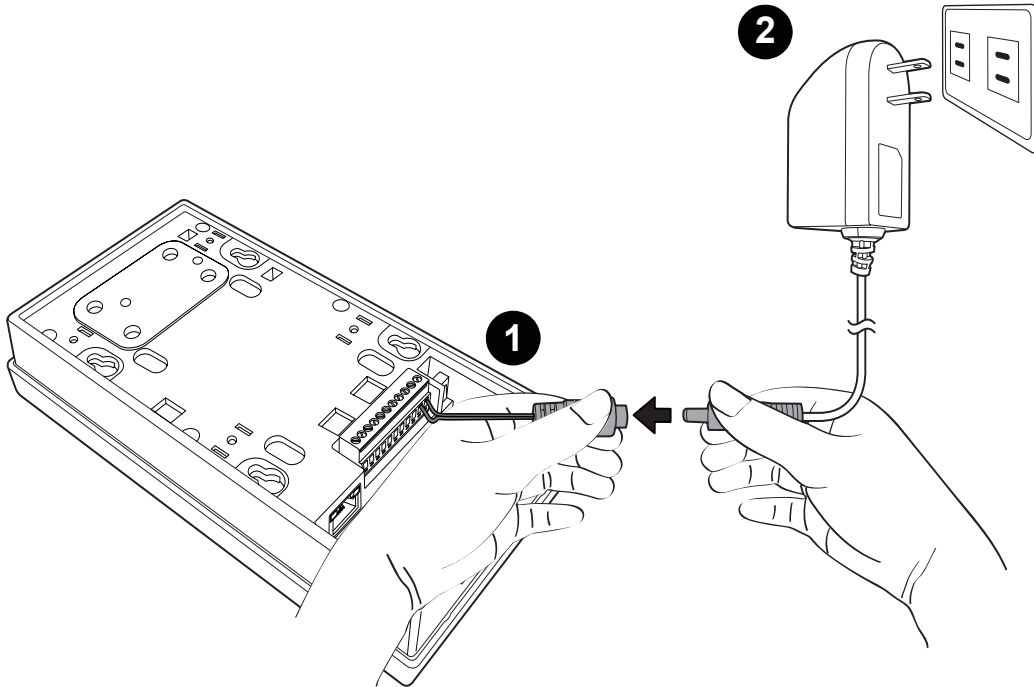

2. MT180 automatically starts when the AC Adapter connects to an external power source. The welcome screen appears before MT180 runs the module checking process.

NOTE: MT180 comes with an antitheft sensor inside the back panel. To setup MT180 before installation, disable the alarm buzzer through one of the following:

1. Attach a magnet behind the sensor on the back panel.
2. Disable the antitheft function in the MT180 firmware (See *Advanced Setting* on page 15).
3. Open the case and short circuit pin2 and pin3 of the J5 connector.

NOTE: When MT180 is installed or used, be sure that you set the backup battery switch to the left to power ON MT180; if you do not use MT180 over a long period of time, please right switch OFF the battery switch located above the terminal block to save the backup battery power.

Identifying LED Indicator Lights

MT180 contains three LED indicators. For detailed descriptions, refer to the following:

Indicator Light	Description
Blinking Yellow	CPU normal operation.
Solid Yellow	Terminal crash.
Solid Green	Operation success. For example: Swipe card success and enter the password success.
Solid Red	Error occurred during operation. For example: Invalid card.

Establishing Terminal-PC Connection

Configure MT180 system settings after connecting power through an external power source. MT180 enables users to link to a host computer via Ethernet or RS485 interfaces for data communication. MT180 can setup through MTTTool or JanitorLite.

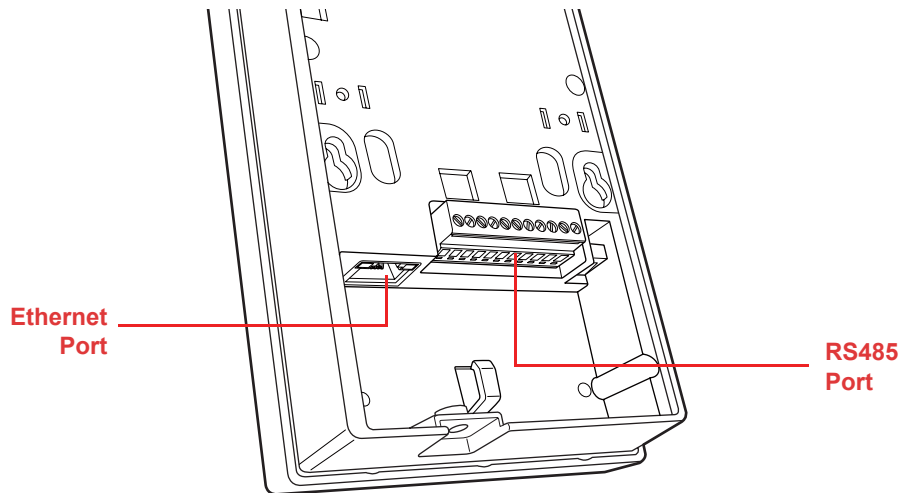

Unitech MTTTool is a development program designed to help technical engineers customize access control, attendance control and manage function modules in a specified terminal (i.e. MT180). Connect MTTTool to MT180 through the following:

1. Connect MT180 and a computer to the network.
2. MT180's default IP address is **192.168.2.127**. Set the computer on the same subnet with MT180.
For example, IP Address **192.168.2.100**; Network Mask **255.255.255.0**.
3. Make sure the TCP port **10002** is not occupied. If yJanitorLite is installed, stop the Unitech MT Service in the Control Panel.
4. Disable any firewalls and execute MTTTool.
5. In MTTTool, on the computer screen, under the **SysSet1** tab, select **WinSocket**. In the **IP/Name** field, input MT180's default IP address **192.168.2.127** and in the **Port** field, input the default port **10002**.
6. Click **Connect**. The status bar at the bottom of MTTTool displays **Connection succeed**, which means MTTTool has successfully connected to MT180.

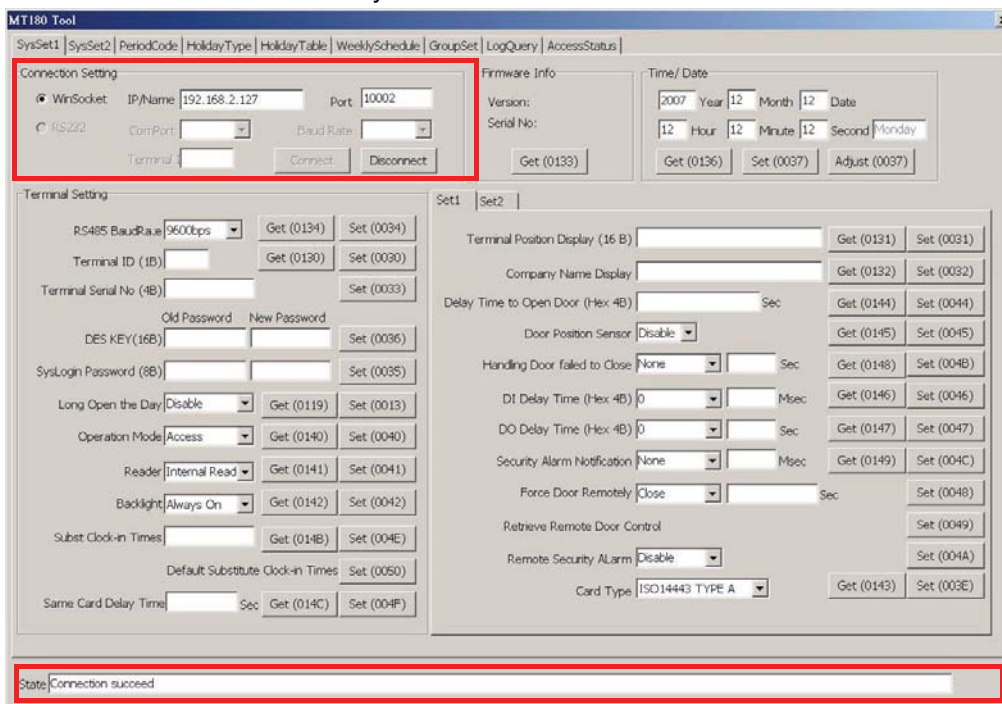

Setting Date and Time

Correct MT180 date and time in MTTTool through the following:

- In MTTTool and under the **SysSet1** tab, locate the **Time / Date** field.
- Input the current date and time.
- Click **Set**.

NOTE: Click **Adjust** to synchronize MT180's time with the computer's time.

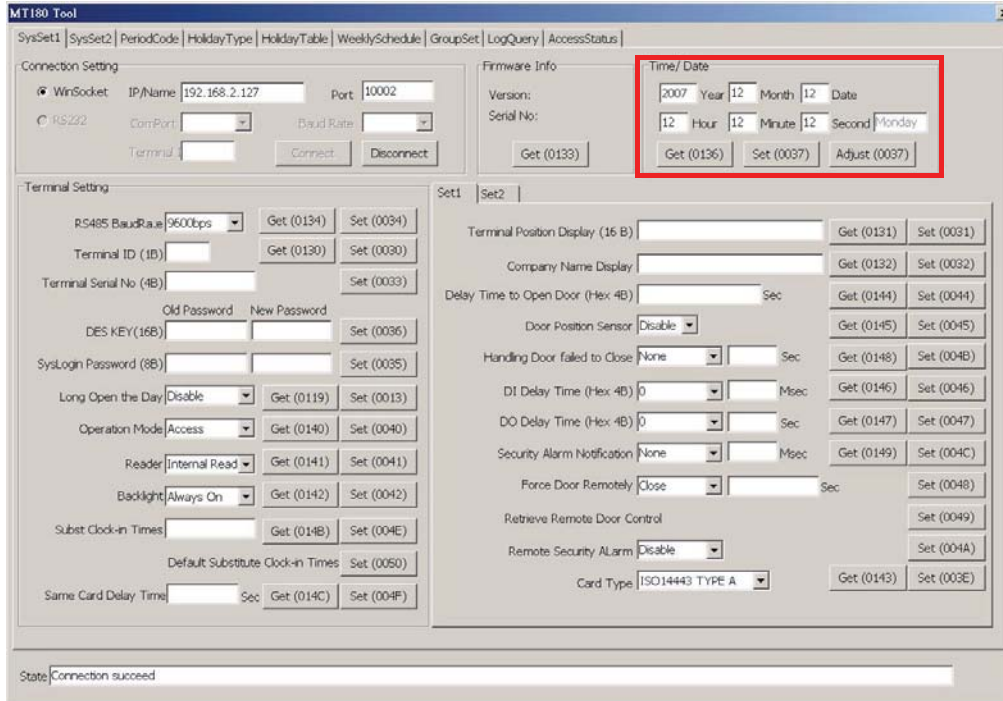

Utilizing Software

JanitorLite allows end users to apply a wide range of applications in the TASHI network. Learn about the main differences between MTTTool and JanitorLite through the following:

Software	MTTool (Free)	JanitorLite (Optional)
Target	Computer/Software Engineering.	End User.
Operation System	Windows on Computer (PC/ Notebook)	Windows on the Computer (PC/Notebook). Windows CE for MT380.
Network	Standalone Terminal.	Terminals/Controllers (As A Server).
Function	Setting/Debugging/Maintenance.	Setting/Managing Small to Large Scale TASHI Networks.
Model	MT180/MT380.	MT180/MT380.

Please contact a Unitech representative to acquire MTTTool. For more details please refer to the MTTTool User's Manual or the JanitorLite User's Manual.

Using the Hardware

Using the Keypad

MT180 contains five function keys and 12 numeric keys.

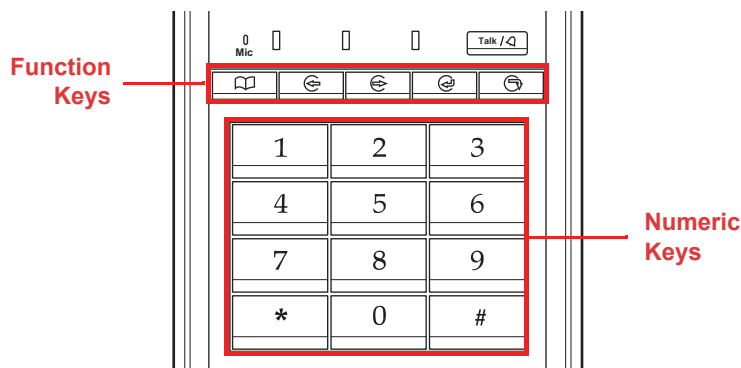

MT180's key functions are described in the following:

Key	Main Function
	Menu. [F1]: Open menu options.
	Clock in. [F2]: Move upward through menu items.
	Clock out. [F3]: Move downward through menu items.
	Break in. [F4]: Returns to the previous menu item.
	Break out. [F5]: Enters a menu item or confirms a setting.

After powering on MT180, the standby screen displays the company name, system time and date, which are configurable by pressing **F1** button to enter the menu options.

While in standby status, press **#** during the password access period, and then follow the onscreen prompt to input 2-digit group number and a 4-digit group access password to open the door.

In Access+Attendance Mode, press **F2** or **F3** to switch into Attendance Mode. Press **F2** or **F3** to choose the work shift and swipe an ID card to clock in. To use the substitute clock in, press any key and follow the onscreen prompt to input a user clock in number.

Using Proximity Reader

MT180 features a standard proximity reader, which is compatible with all 125kHz EM, 125kHz HID, and 13.56MHz MiFare cards.

Utilize MTTool to add a card through the following:

1. Connect MT180 to a computer network. See *Establishing Terminal-PC Connection* on page 3.
2. Execute MTTool on the computer.
3. Enter the correct IP address and port number. Click **Connect**.
4. Follow MT180 onscreen instructions to enter the Card Info Query option. See *General Settings* on page 12. Swipe the card over the Proximity Reader. MT180 beeps three times. The screen displays **Invalid Card** with the card number.
5. In MTTool, under the **SysSet2** tab, in the **Card Setting** box input the card number, user name, group number, password and etc.
6. Click **Add a Card No.** The status bar at the bottom of the MTTool screen displays **Successful terminal response** informing that MTTool has successfully send the card to MT180.

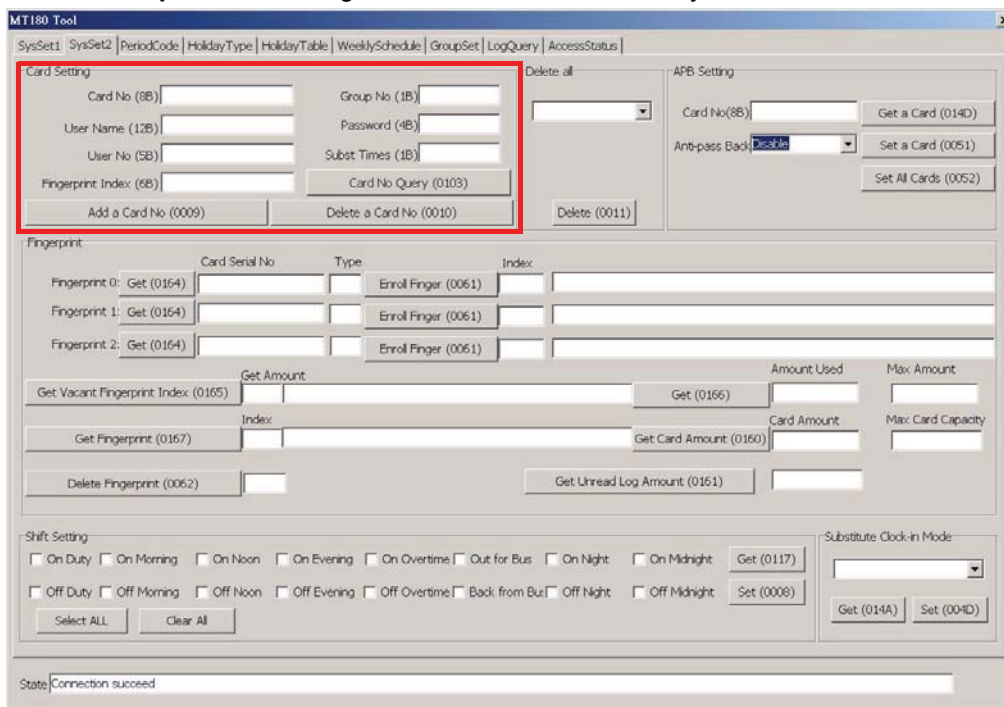
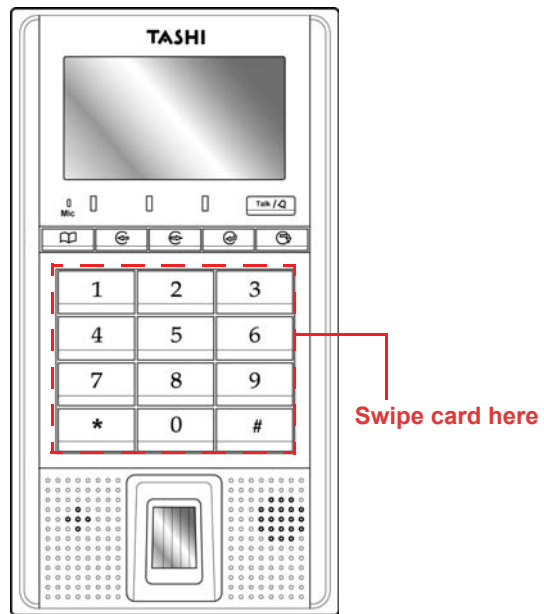

NOTE: When adding a card, it is necessary to at least fill in the card number, user name, group number and password. Otherwise, a prompt appears to ask for this specific information.

Utilize JanitorLite to add a card through the following:

1. Connect MT180 to a computer network. See *Establishing Terminal-PC Connection* on page 3.
2. Enable Unitech MT Service in the Control Panel.
3. Click **start** → **All Programs** → **JanitorLite** → **JanitorLite**.

4. Click **User** → **User Management**.
Right-click **All group**. Select **Append** → **Group**. The UserGroup Setting window appears.
Enter a group name (for example, **DEMO**). Click **Apply** → **OK**.

5. Right-click **DEMO**. Select **Append** → **Entity**. The User setting window appears.
Enter a user name (for example, **DEMOUSER**). In the **CardNo.** field, click **+**. The Card setting window appears.

NOTE: Make sure the card type is compatible with the reader.

6. Follow MT180's onscreen instructions to enter the Card Info Query. See *General Settings* on page 12. Swipe the card over the Proximity Reader. MT180 beeps three times. The screen displays **Invalid Card** with the card number.
7. Input the card number in the **Card No.**
8. Click **Apply** → **OK** to return to the User setting window.
9. Click **Apply** → **OK**.

NOTE: The card will not immediately be to MT180, but it will be sent periodically via Unitech MT Service. The default value is five minutes. It is optional to modify the interval setting in the MT Service Tool.

Using Fingerprint Reader

MT180 has an optional integrated Fingerprint reader that enrolls and verifies fingerprints. The reader can store up to 7,000 fingerprint templates. Each user is allowed to have a maximum of three fingerprints.

NOTE: Make sure the card is valid.

Enroll a fingerprint through the following:

1. Press **F1**.
2. Select **General** → **Add Finger**.
3. Swipe the card.
4. Place a finger in the Fingerprint Reader and adjust the finger placement according to the onscreen instructions.
The screen may inform that the finger is too high, too low, too left, too right, too small or no finger. Remove and place the finger on the fingerprint reader three times.
5. Press **F3** to enroll another fingerprint when the screen displays **Collect finger OK. Continue?**. Press **F5** to stop.
6. After enrolling the finger on the fingerprint Reader three times, the screen displays **CollectFinger OK** and return to the standby screen.

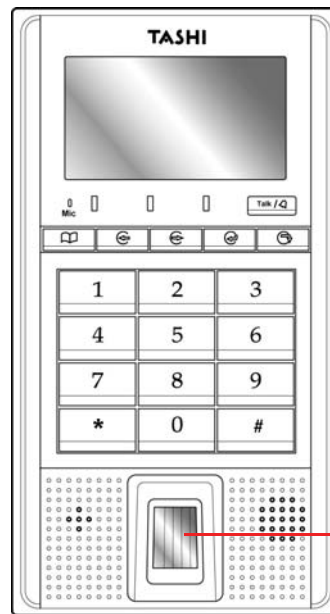

Utilize MTTool to collect fingerprints through the following:

1. Connect MT180 to a computer network. See *Establishing Terminal-PC Connection* on page 3.
2. Execute MTTool on the computer.
3. Enter the correct IP address and port number. Click **Connect**.
4. Under the **SysSet2** tab, enter a card number in the **Card No.** field and click **Card No Query**. Value **FFFFFFFFFFFF** displays in the **Fingerprint Index** field, which indicates empty fingerprint data for the card.
In the **Card Serial No** field, input the card number and click **Get**. Now fingerprint data can extract from this card.

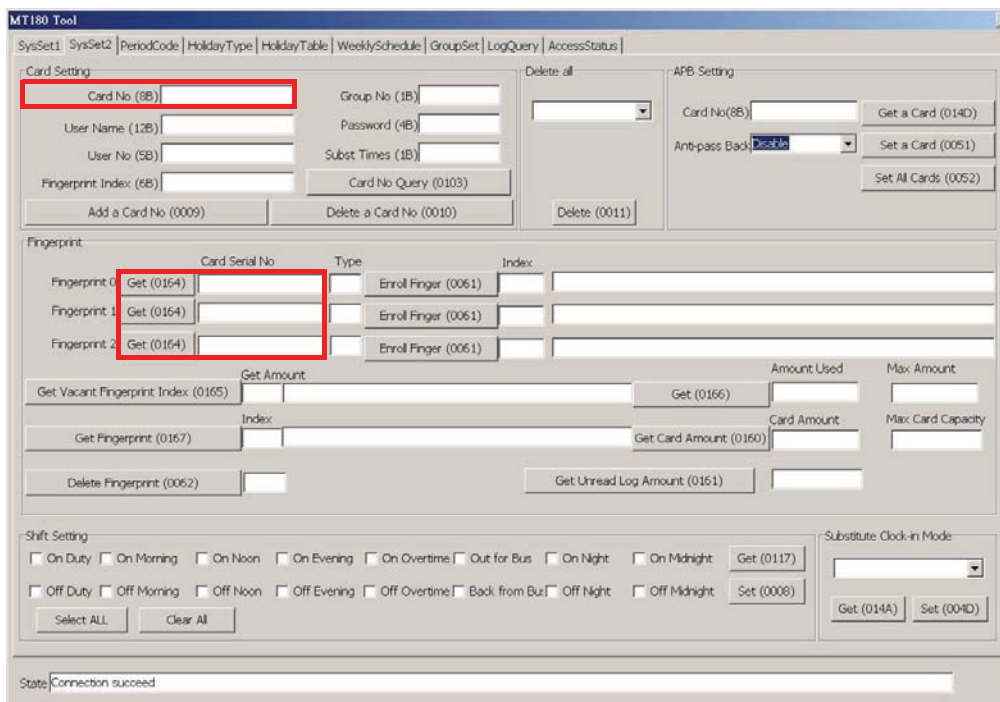

5. To enroll the first fingerprint for this card, input **0000** in the **Index** field and click **Enroll Finger** (1). Input **00000000000** in the **Fingerprint Index** field and click **Add a Card No** (2).

Utilize JanitorLite to collect fingerprints through the following:

1. Connect MT180 to a computer network. See *Establishing Terminal-PC Connection* on page 3.
2. Enable Unitech MT Service in the Control Panel.
3. On the computer screen, click **start** → **All Programs** → **JanitorLite** → **JanitorLite**.
4. Click **System** → **SysParams Setting**. The SetParams window appears. Specify the IP address and port number of the fingerprint reader. Click **OK**.

- Click **User** → **User Management**.
Double-click **DEMOUSER**. The User setting window appears.
Click **FingerPrint**. The FingerPrint window appears.

- To collect fingerprint data from MT180, click **Read**. The value **Not set** changes into **Already Setting**, if the fingerprint reading is successful. Click **Apply**.

- Click **Apply**, and then **OK**.

Using DECT Phone (Optional)

MT180 has an optional DECT module that can make intercom calls. The procedures for registering MT180 to DECT base stations may vary between phone service providers. MT180 can register up to four base stations.

Register MT180 to an AWTEK base station through the following:

NOTE: Before registration, make sure the voice module is properly installed while MT180 powers on through the running module checking process.

1. Press and hold  on the back panel of the base station for 15 - 20 seconds. The LED indicator on the front panel flashes.
2. Press **F1** to enter the terminal menu.
3. Press **F3** to select the **Advanced** option.
4. Press **F5** to enter the **Advanced** option.
5. Enter the system login password (**12345678**, by default) and press **F5** to confirm.
6. Enter the **Voice Park** option. The screen displays **Voice Module Parking OK** when registration is completed.

Make an intercom call by using an AWTEK DECT phone through the following:



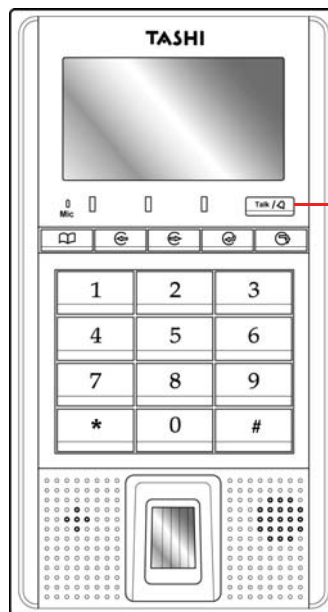







1. Press **Talk/Doorbell**. MT180 connects to the DECT phone while the screen displays **Connect... Please wait!**.
The LED indicator on the DECT phone flashes and the phone rings with the MT180's HS number (**HS1**, by default) shown onscreen.
2. Press answer  to receive the call. MT180 beeps while the screen displays **Calling...**, the duration of this call is shown on the DECT phone screen.
3. Press ***** on the DECT phone, to trigger the door open.



NOTE: Ensure the relay wiring is ready.

Cancel registration by using a registered handset.

Cancel MT180's registration on an AWTEK DECT phone handset through the following:

1. Press  to enter the main menu.
2. Press  or  to select the **BS setting** option. Press  to confirm. The screen displays **Waiting...**
3. Follow the onscreen prompt to input the base station's Master PIN (**0000**, by default) and press  to confirm. A confirmation sound beeps, and the sub menu opens.
4. Press  or  to select the **Remove HS** option. Press  to confirm. The screen displays **Remove HS1/2/3/4/5?**
5. Follow the onscreen prompt to input MT180's HS number (**1/2/3/4/5**, by default) or press  to cancel.
1. Press  to confirm. A confirmation sound beeps, and the screen displays **Not sub** when this setting is done.

Onscreen Setting

This chapter introduces MT180's general and advanced settings.

General Settings

Press **F1** to enter the terminal menu.

Press **F5** to enter the **General** option.

Five options are available:

- SysInfoQuery.
- CardInfoQuery.
- AddFinger.
- ModifyCardPIN.
- LongTimeDoor.

```
>OperationSel<
>>General
X Advanced
```

Enter the **SysInfoQuery** option to get the terminal information.

The five options are described through the following:

Sys Info Query	Description
Location	Displays the terminal location (#Controller 01 , by default).
Version&SNR	Displays the terminal firmware version and serial number.
WorkMode	Displays current operation mode (Access Mode , by default).
ModuleStatus	Displays the modules status of Flash1, Flash2, Finger, Reader1, Reader2, Voice and Network. If the module operates normally, the screen displays ok ; if not, the screen displays error .
Card&Finger	Displays the maximum card/fingerprint capacity and current card/fingerprint count.

Enter the **CardInfoQuery** option. Follow the onscreen prompt to swipe a card. The screen displays the card number, user name, user number and group number preset in JanitorLite or MTTool.

Enter the **AddFinger** option. Follow the onscreen prompt to swipe a card. The screen displays an Operation Notice. Follow the operation notice and place a finger on the fingerprint reader. Each card allows to enroll a maximum of three fingerprints.

Enter the **ModifyCardPIN** option. Follow the onscreen prompt to swipe a card. The screen displays **Input old PIN**. Using the numeric keypad to enter the card password and press **F5** to confirm. The screen displays **Input new PIN**. And **Input again**. The screen displays **Modify Card PIN Success** upon successful modification.

Enter the **LongTimeDoor** option. It is possible to enable/disable the open door function for a select period of time. Follow the onscreen prompt to swipe the card before this setting is activated (Whether **Turn on** or **Turn off** is selected) and the screen displays **Auto-OpeningDoorTurn on/off**.

Advanced Settings

Press **F1** to enter the terminal menu.

Press **F3** to select the **Advanced** option.

Press **F5** to enter the **Advanced** option.

Using the numeric keypad to enter the default system login password **12345678**, and press **F5** to confirm. Ten options are available:

```

>OperationSel<
X General
>> Advanced
    
```

- Set Device ID.
- SetBaudrate.
- SetLanguage.
- SetBacklight.
- SetNetwork.
- VoicePark.
- Reboot.
- ResumeDefault.
- Anti-thief.
- Exit.

Enter the **Set Device ID** option. Specify the terminal ID (**001**, by default).

Enter the **SetBaudrate** option. Select a baud rate (**115200 bps**, by default) to match the computer. Available rates are **9600**, **19200**, **38400** and **115200** bps. The larger number equates to a faster connection speed.

Enter the **SetLanguage** option to switch the terminal language. Current supported languages are English, Simplified Chinese and Traditional Chinese.

Enter the **SetBacklight** option to set the backlight behavior. Select **AlwaysTurnOn**, to have the backlight to stay on all the time. Select **AlwaysTurnOff**, to have the backlight turn off all the time. Select **TurnOnOnwork**, to have the backlight turn on when a button is pressed.

Enter the **SetNetwork** option to configure the network settings.

Set Network	Description
Set Net Password	Enter the network password.
Set IP Address	Enter the IP address (192.168.2.127 , by default).
Set Net Mask	Enter the network mask (255.255.255.0 , by default).
Set Gateway	Configure the network gateway.
Set Port Number	Specify a local port number (10002 , by default). The maximum valid port number is 65535 .
Set Baud Rate	Select a serial port baud rate (115200 bps , by default). Available rates are 9600 , 19200 , 38400 , 57600 and 115200 bps . The larger number equates to a faster connection speed.
Confirm Setting	Select Yes to confirm the network settings. The screen displays Modify network success! . Select No to go back to SetNetwork options.

Enter the **VoicePark** option to detect the optional DECT function. If the DECT phone is properly installed, the screen displays **ParkOK**. If not, the screen displays **ParkError**. If the voice module is not installed or installed improperly, the screen displays **VoiceModuleParkingError**.

Enter the **Reboot** option. Select **Yes** to reboot the system. The screen displays **Device reboot. Please wait!** and the system reboots itself. Select **No** to go back to the **Advanced** options.

Enter the **ResumeDefault** option. Select **Yes** to reset the factory defaults. The screen displays **Resume default. Please wait!** and MT180 reboots itself. Select **No** to go back to the **Advanced** options.

Enter the **Anti-thief** option. Select **Yes** to enable the sensor and go back into the **Advanced** options. Select **No** to disable the sensor and go back to the **Advanced** options.

Enter the **Exit** option. Log out the system advanced settings and return to the standby screen.

Advanced Setting

This chapter introduces how to utilize MT180 configuration software for diverse applications.

Shift Attendance

Utilize MTTool to manage time and attendance through the following:

1. Set MT180 to a computer on the same subnet network.
2. Execute MTTool on the computer.
3. In MTTool and under the **SysSet1** tab, select **WinSocket**. Input the IP address (for example, **192.168.110.230**). Click **Connect**.

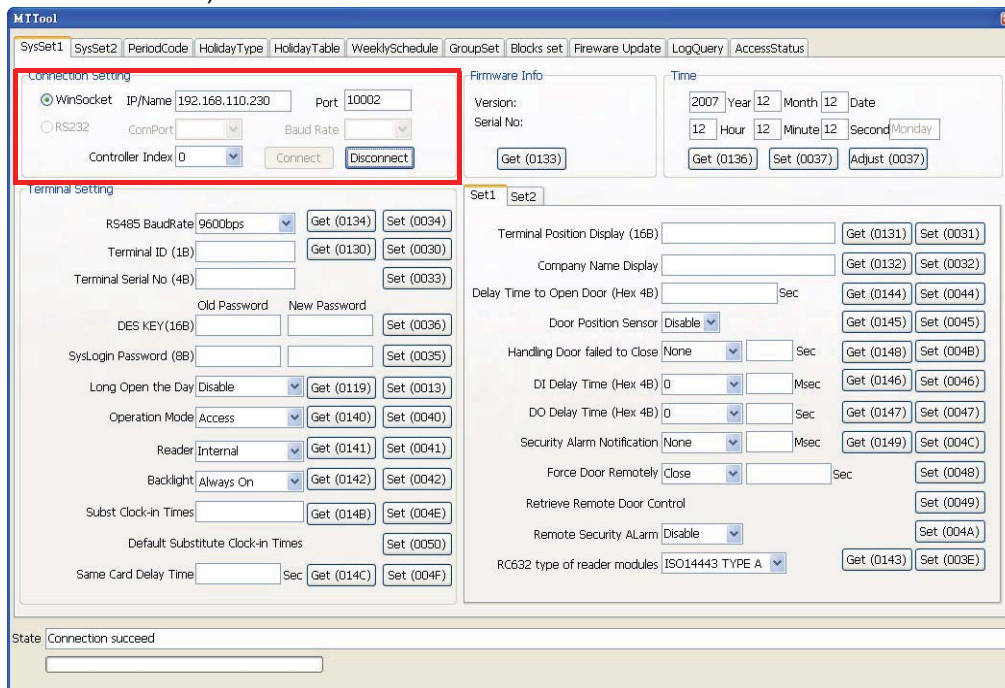

NOTE: See *Advanced Settings* on page 13 to set MT180's IP address.

- In the **Time** box, click **Adjust** to synchronize the system time with the computer.

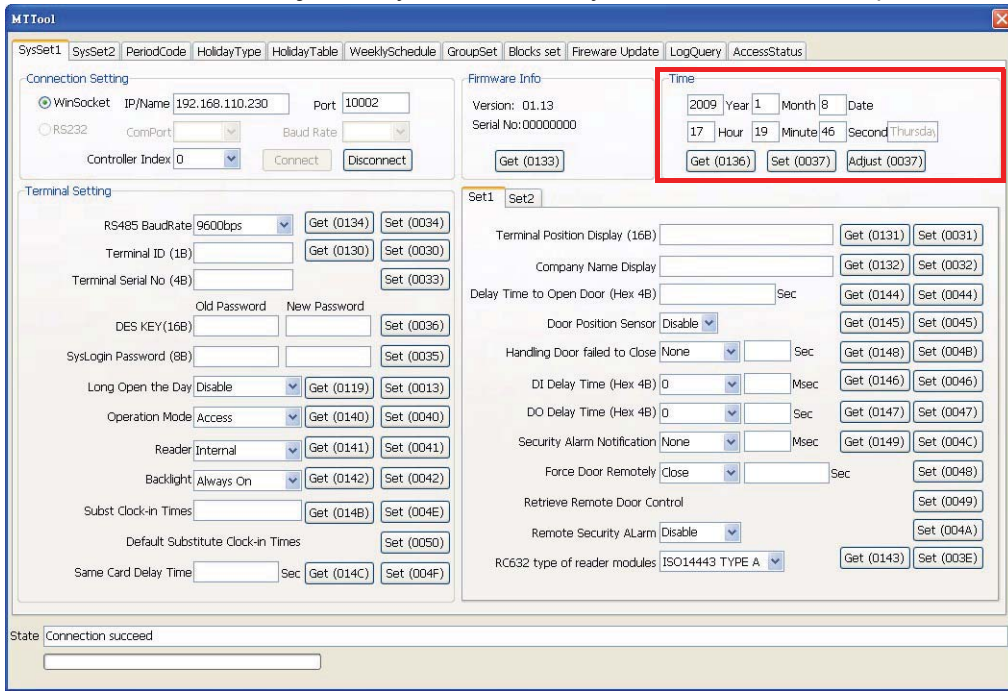

- Click **Get** to double check MT180's date and time settings.
- In the **Terminal Setting** box, select **Attendance** from the **Operation Mode** drop down menu. Click **Set**.

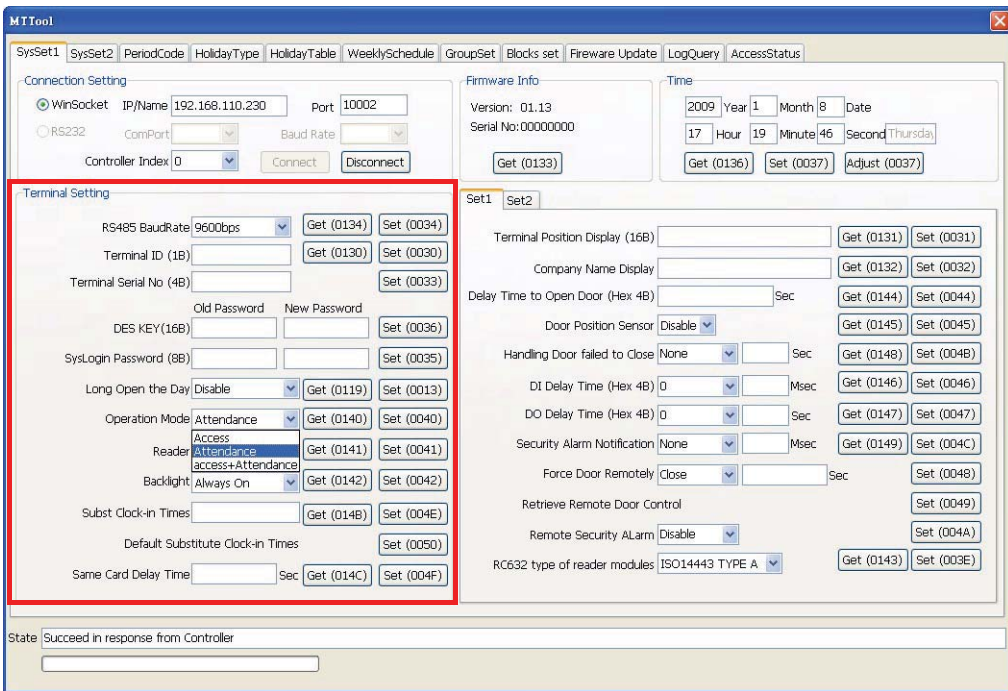

- Under the **SysSet2** tab, in the **Shift Setting** box, check a desired work shift (for example, **On Morning**). Click **Set**.

The screenshot shows the MTTool application window with the SysSet2 tab selected. The 'Shift Setting' section is highlighted with a red box. It contains several radio button options for work shifts: On Duty, **On Morning** (selected), On Noon, On Evening, On Overtime, Out for Business, On Night, On Midnight, Off Duty, Off Morning, Off Noon, Off Evening, Off Overtime, Back from Business, Off Night, and Off Midnight. There are 'Get (0117)', 'Set (0008)', 'Select ALL', and 'Clear All' buttons. The 'Card Setting' section is also visible, with fields for Card No (8B), Group No (1B), User Name (12B), Password (4B), User No (5B), and Subst Times (1B). There are buttons for 'Add a Card No (0009)', 'Delete a Card No (0010)', and 'Delete (0011)'. The 'APB Setting' section has fields for Card No (8B) and buttons for 'Get a Card (014D)', 'Set a Card (0051)', and 'Set All Cards (0052)'. The 'Fingerprint' section has fields for Fingerprint 0, 1, and 2, and buttons for 'Get (0164)', 'Enroll Finger (0061)', 'Get Vacant Fingerprint Index (0165)', 'Get (0166)', 'Get Fingerprint (0167)', 'Index', 'Get Card Amount (0160)', 'Delete Fingerprint (0062)', and 'Get Unread Log Amount (0161)'. The 'State' field shows 'Connection succeed'.

- In the **Card Setting** field, input the card number, user name, user number, group number and etc. Click **Add a Card No**.

The screenshot shows the MTTool application window with the SysSet2 tab selected. The 'Card Setting' section is highlighted with a red box. It contains fields for Card No (8B) with the value '00000000ACEA9F9E', Group No (1B) with the value '0', User Name (12B) with the value 'Attendance', Password (4B) with the value '12345678', User No (5B) with the value '000000000000000001', and Subst Times (1B) with the value '5'. There are buttons for 'Add a Card No (0009)', 'Delete a Card No (0010)', and 'Delete (0011)'. The 'APB Setting' section has fields for Card No (8B) and buttons for 'Get a Card (014D)', 'Set a Card (0051)', and 'Set All Cards (0052)'. The 'Fingerprint' section has fields for Fingerprint 0, 1, and 2, and buttons for 'Get (0164)', 'Enroll Finger (0061)', 'Get Vacant Fingerprint Index (0165)', 'Get (0166)', 'Get Fingerprint (0167)', 'Index', 'Get Card Amount (0160)', 'Delete Fingerprint (0062)', and 'Get Unread Log Amount (0161)'. The 'Shift Setting' section is visible with 'On Morning' selected. The 'State' field shows 'Connection succeed'.

NOTE: See *General Settings* on page 12 to acquire the card number.

- Under the **WeeklySchedule** tab, in the **Weekly Schedule Setting** box, select **Weekly Attendance Schedule**.

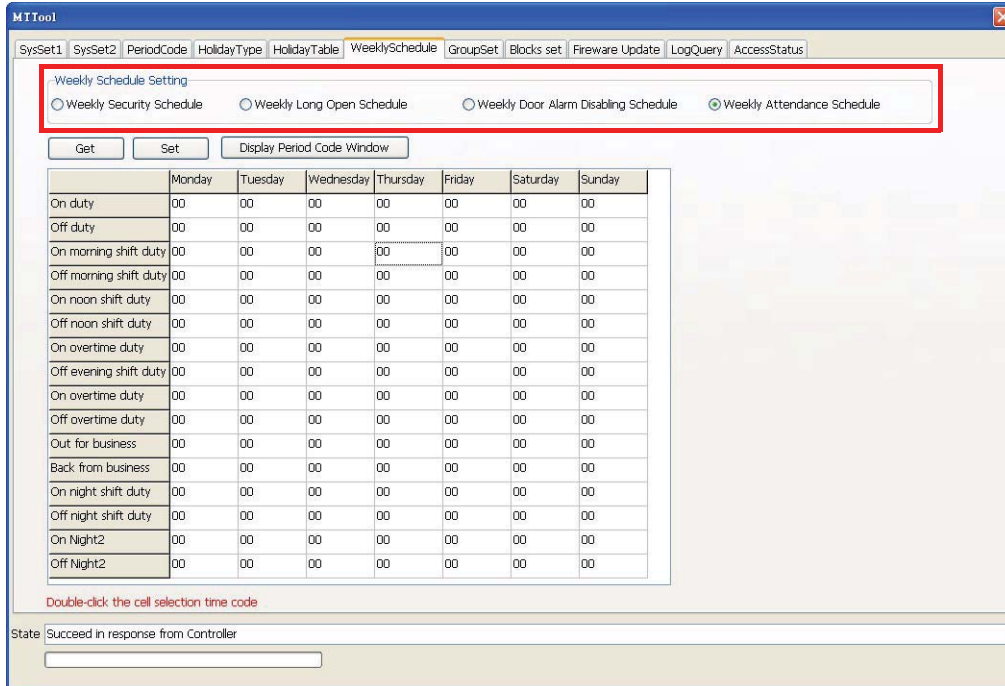

- Double-click a time code cell (for example, **On morning shift duty**). The Period Code window appears.
- Click a desired time period (for example, **00002359**) to set for 24 hours of access during this weekday. Click **OK**.

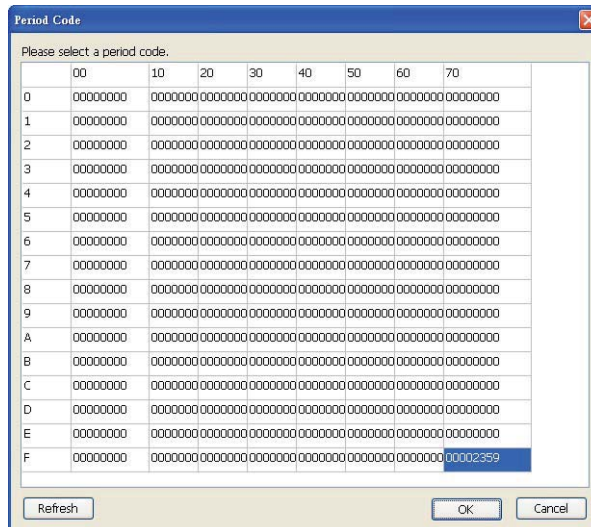

12. Select time period codes for this work shift in other weekdays. The period code **7F** displays on the shift row. Click **Set**.

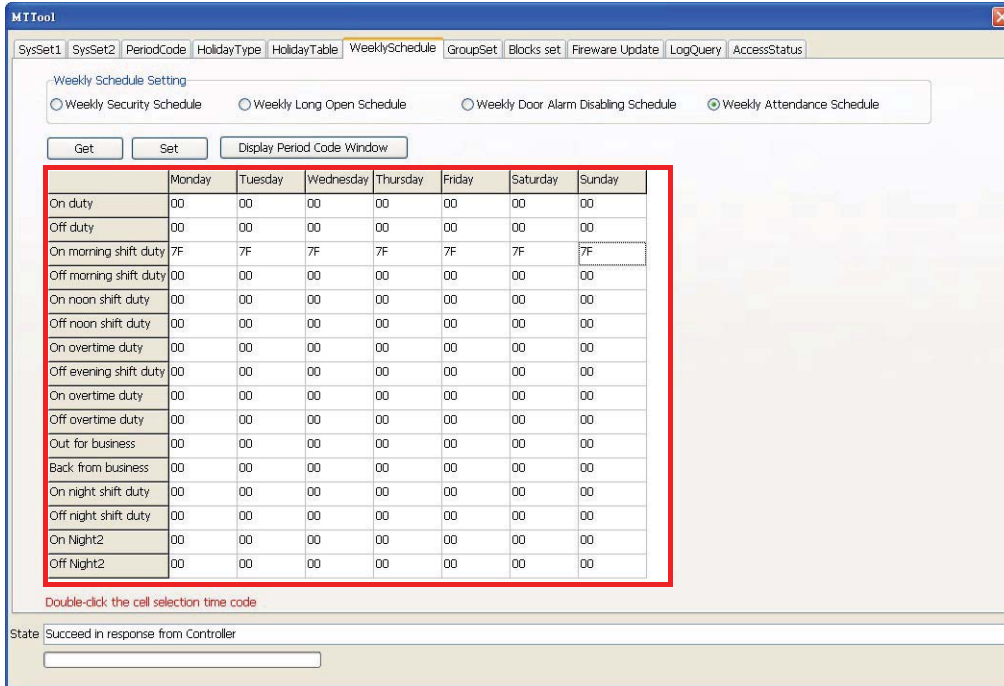

13. In the **GroupSet** tab, select the desired group (for example, **0**).

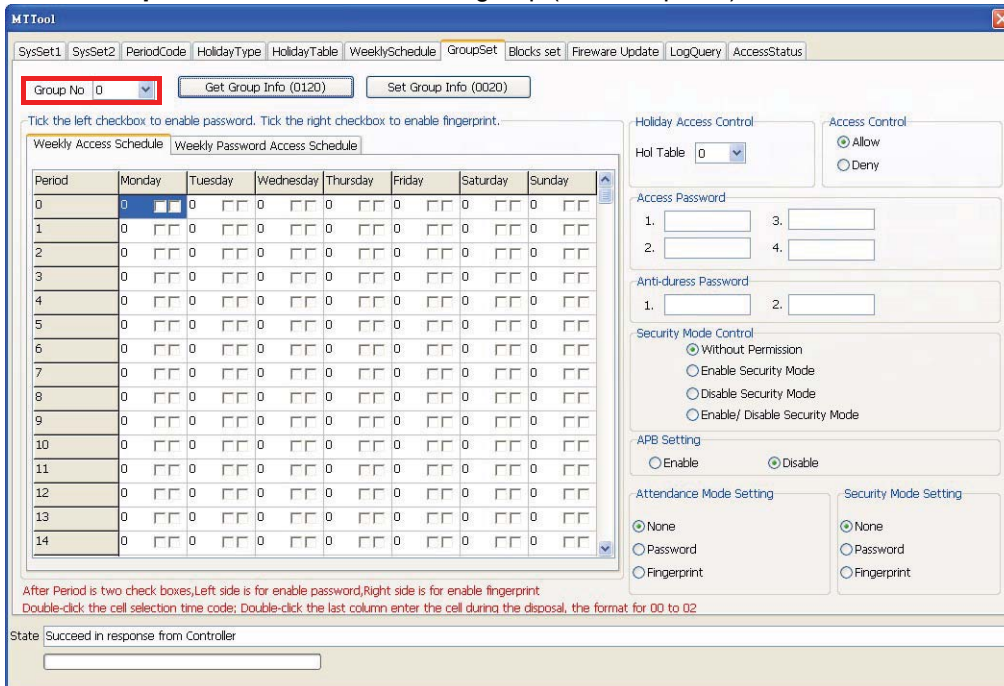

14. Double-click on a desired table cell (for example, **row 1 / column Thursday**). The Period Code window appears.

- Click a desired time period (for example, **00002359**) to set for 24 hours of access in this week-day. Click **OK**. The period code **7F** displays on the table cell.

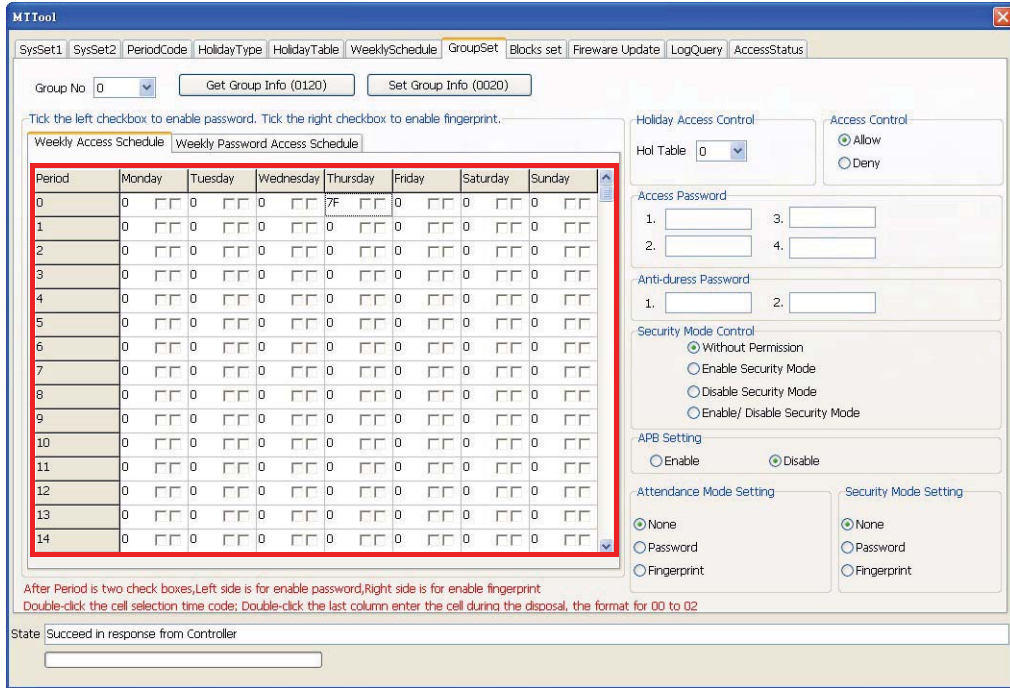

- In the **Attendance Mode Setting** box, select **None**.

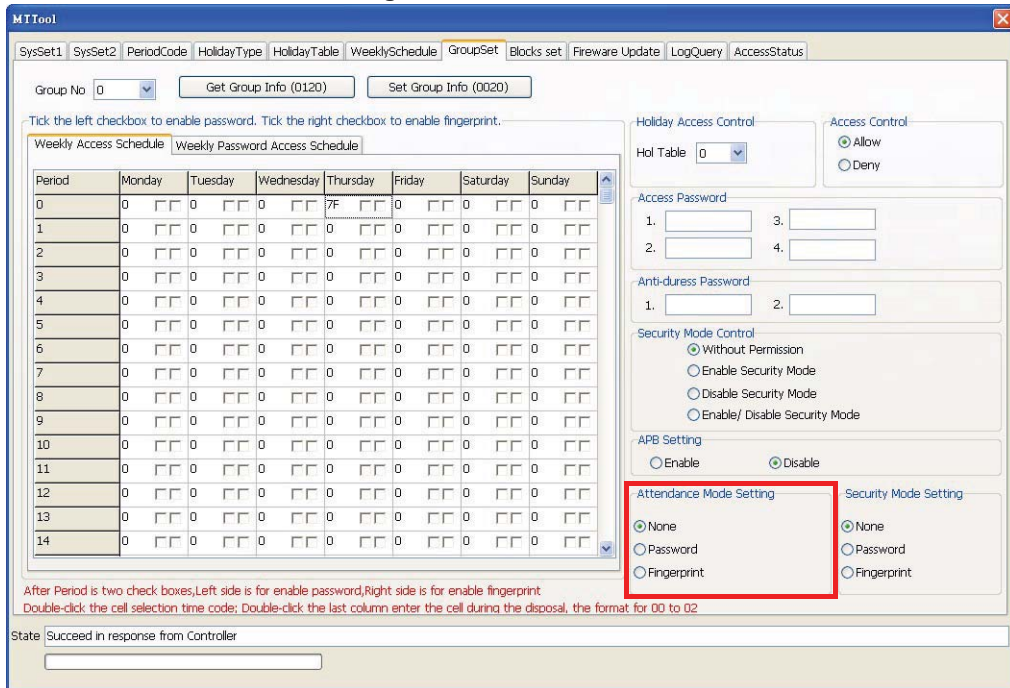

- Click **Set Group Info**, on the top center of the screen.

Utilize JanitorLite to manage time and attendance through the following:

- Set MT180 to a computer on the same subnet network.

NOTE: Switch the controller operation mode to **Attendance**, and synchronize the date and time in MTTool.

- On the computer screen click **start** → **All Programs** → **JanitorLite** → **JanitorLite**.
- Click **Controller** → **Controller Management**.

4. Right-click **All Groups**, and click **Append** → **Group** to add a new controller group. The Controller Group Management window appears.
5. Enter the controller group name (for example, **DEMO**). Click **Apply**, and then **OK** to return to the Controller Group Management window.

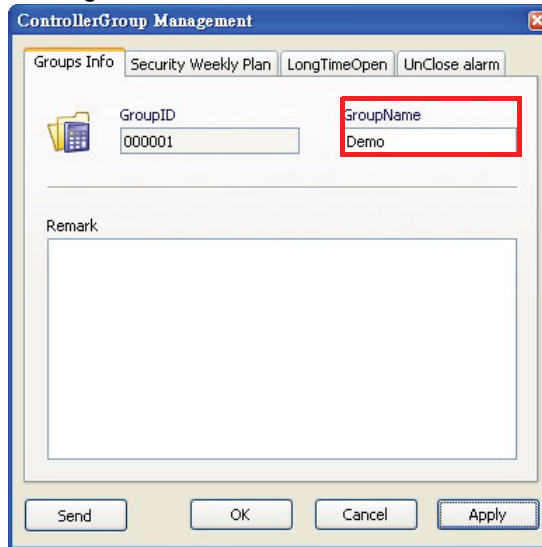

6. Right-click the desired group (for example, **DEMO**), and click **Append** → **Entity** to add a new controller. The Controller Management screen appears.
7. Enter the controller name (for example, **No.1**) in the **ContorllerName** field.
8. Input MT180's IP address (for example, **192.168.110.230**) in the **IPHost** field. Click **Apply**.

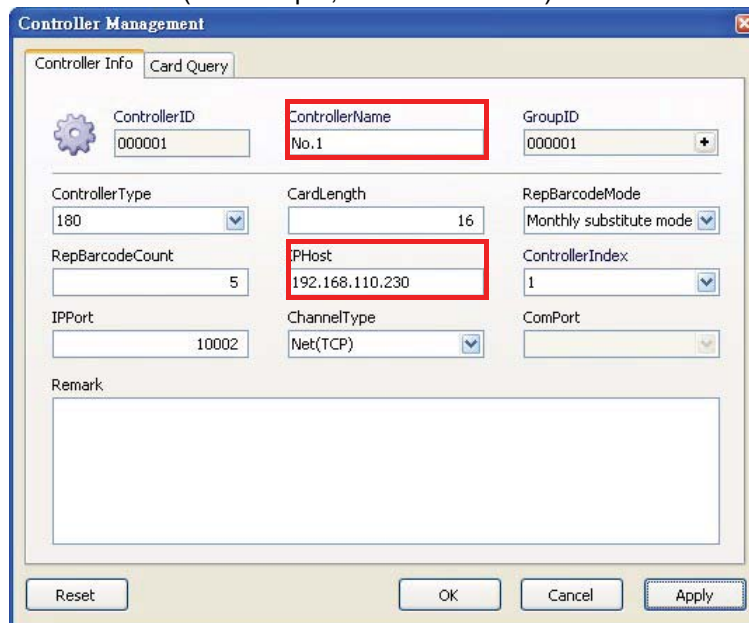

9. Click **Reset** to reset data in this controller. A window appears, asking to reset. Click **Yes**. MT180 screen displays messages **Please wait! EraseFingerInfo.**, **Please wait! Erase Log...** and **Please wait! EraseCardInfo**. MT180 returns to the standby screen when the reset process is complete.

NOTE: Alternatively, reset data under the **SysSet2** tab in MTTTool. In the **Delete all** field, select to delete all cards, logs, fingerprints, and click **Delete**. In the **Shift Setting** field, click **Clear All** and then **Set**.

10. Click **OK** to return to the Controller Group Management window.
11. Click **User(U)** → **User Management**.
12. Right-click **All Groups**, and click **Append** → **Group** to add a new user group. The User Group Setting window appears.

13. Enter the user group name (for example, **DEMO**). Click **Apply**, and then **OK** to return to the User Group Setting window.

The screenshot shows a dialog box titled "UserGroup Setting" with a "Group Info" tab. It contains two input fields: "GroupID" with the value "000001" and "GroupName" with the value "Demo". The "GroupName" field is highlighted with a red rectangular box. Below these fields is a "Remark" text area. At the bottom, there are buttons for "Send", "OK", "Cancel", and "Apply".

14. Right-click the desired group (for example, **DEMO**), and click **Append** → **Entity** to add a new user. The User setting window appears.
15. Enter the user name (for example, **TAttendance**) in the **UserName** field.

The screenshot shows a dialog box titled "User setting" with a "User Info" tab. It contains several input fields: "UserID" (0000000001), "UserName" (TAttendance), "CardNo" (with +/- buttons), "CardKey" (12345678), "GroupID" (000001), "GroupName" (Demo), "ID No.", "Email", "Mobile", "Telephone", "Address", "Account", and "Remark". The "UserName" field is highlighted with a red rectangular box. There are also radio buttons for "Male" and "Female". At the bottom, there are buttons for "FingerPrint", "OK", "Cancel", and "Apply".

16. Inside the **CardNo** field, click **+**. The Card Setting window appears.

17. Input the card number in the **Card No.** field. Click **Apply**, and then **OK** to return to the User setting window.

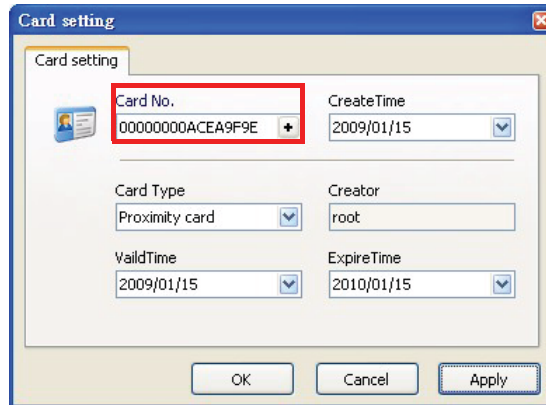

NOTE: See *General Settings* on page 12 to acquire the card number.

18. Click **OK** to return to the User Group Setting window.
19. Click **Permit(P)** → **Permit Management**.
20. Select the desired user group (for example, **DEMO**), and click **Setting** on the toolbar. The Selected Controllers window appears.
21. Select the desired controllers (for example, **No.1 DEMO**), and click **OK** to return to the Janitor-Lite - [Permit Management] window.

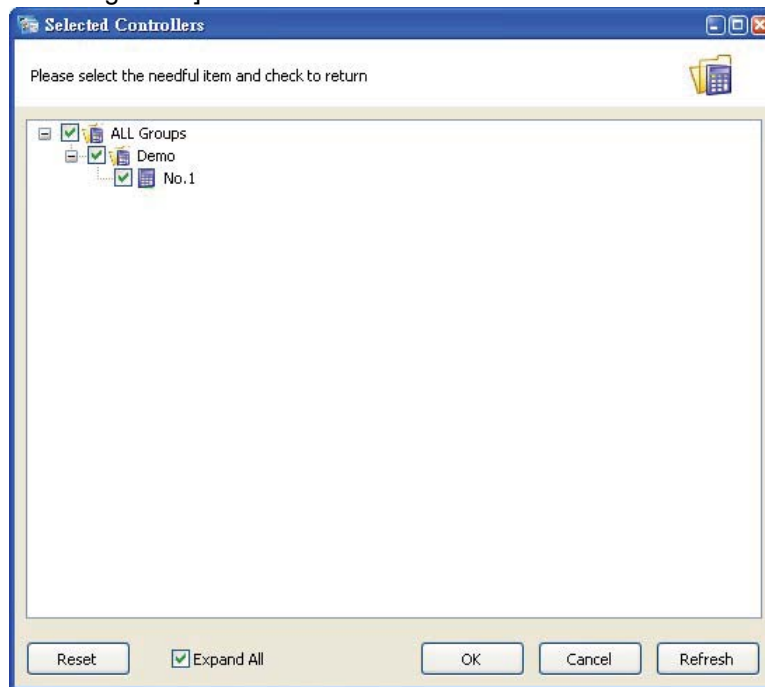

22. Click **Attendance** → **Duty Management**.

23. Under the **Usable Shift** tab, select a desired work shift (for example, **On Morning**).

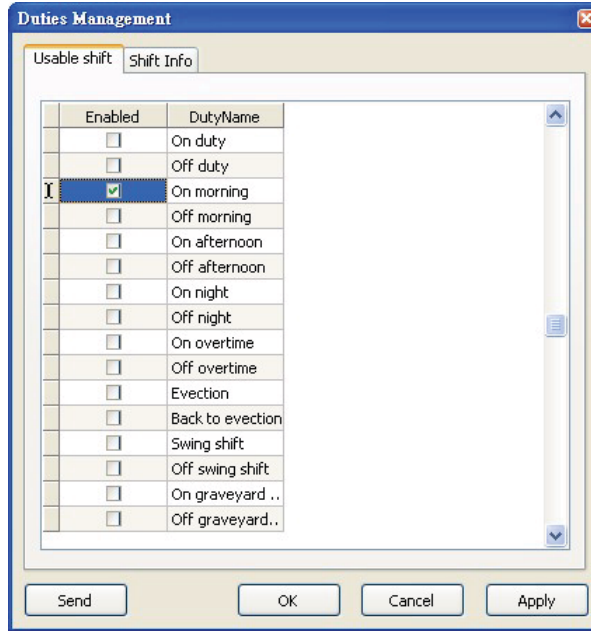

24. Under the **Shift Info** tab, select a desired weekday from the drop down menu (for example, **Thursday**).
25. Double-click **+** inside the **PeriodID** field. The Selected periods window appears.
26. Click a desired time period (for example, PeriodID **127**) to set for 24 hours of access in this weekday. Click **OK** to return to the Duty Management window.

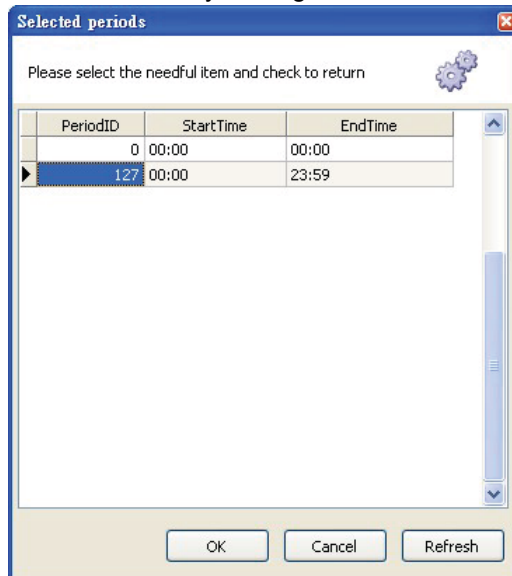

- Click **Apply** → **Send** to immediately send the command to the controller. A window appears with the message **Setting Successfully**.

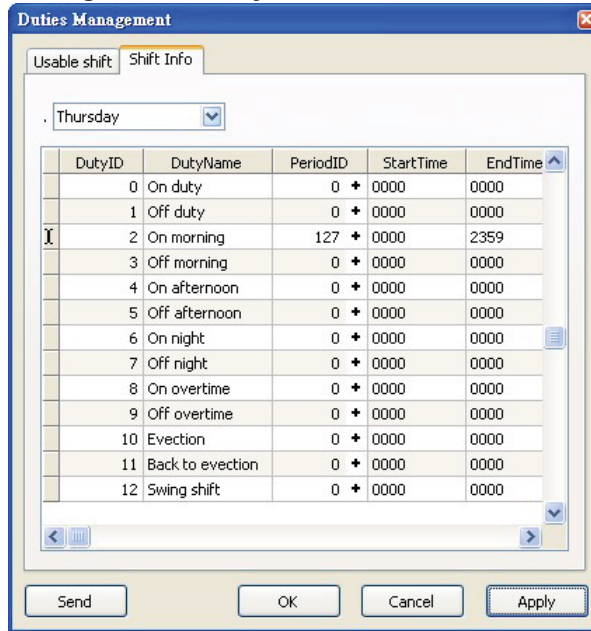

- Click **OK** to exit.

Scenario I - Swipe Card to Clock In

Swipe a card on the Proximity Reader while the standby screen on MT180 displays the desired work shift name (for example, **morning shift work**).

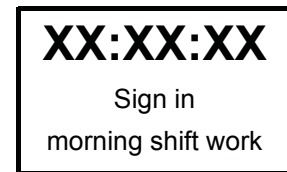

The user name (for example, **TAttendance**) and the clock in time display onscreen.

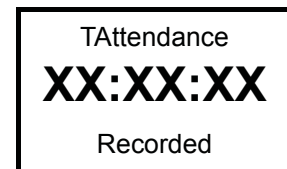

In MTTool, under the **LogQuery** tab, click **Get Latest Log**. Find the attendance record.

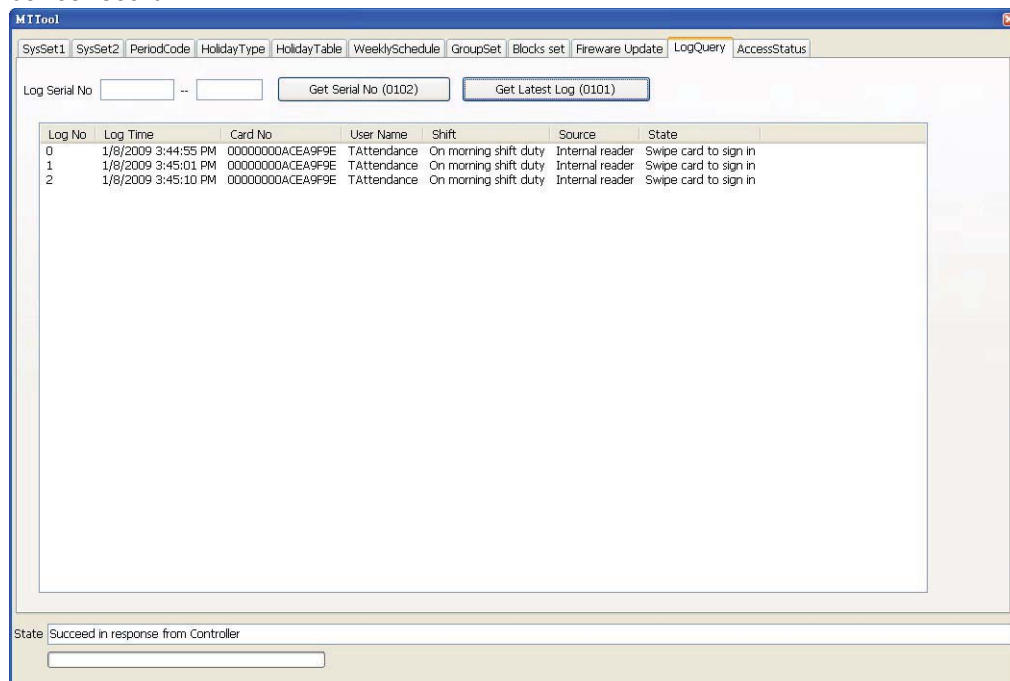

In JanitorLite, click **Report** → **Attendance Report**. Under the **Conditions** tab, filter the user, controller, and date, and click **OK**. The attendance record displays under the **Preview** tab.

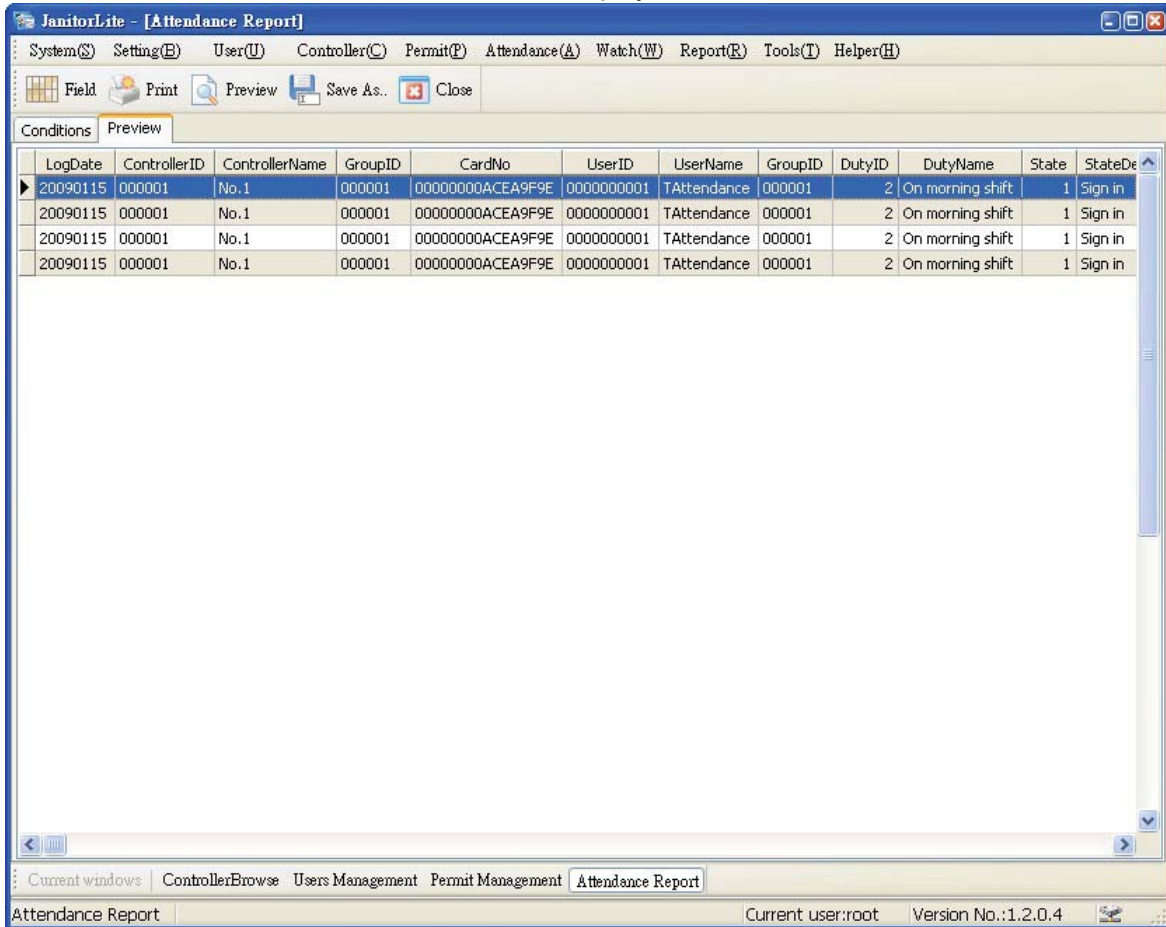

Security Operation

To prevent unauthorized access, MT180 can setup a secure area which is enclosed by the terminal and surrounding sensors. The following security system architecture demonstrates a closed-loop connection through the terminal, door sensor and window sensor.

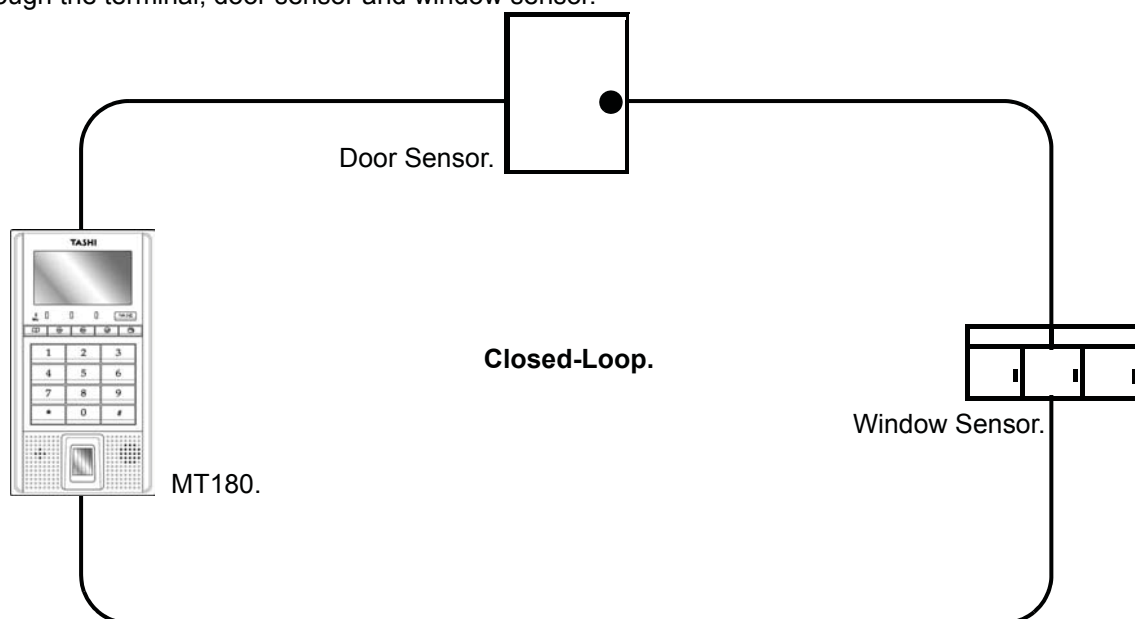

The following security system architecture demonstrates an open-loop system, which disconnects the door sensor and triggers MT180's security alarm.

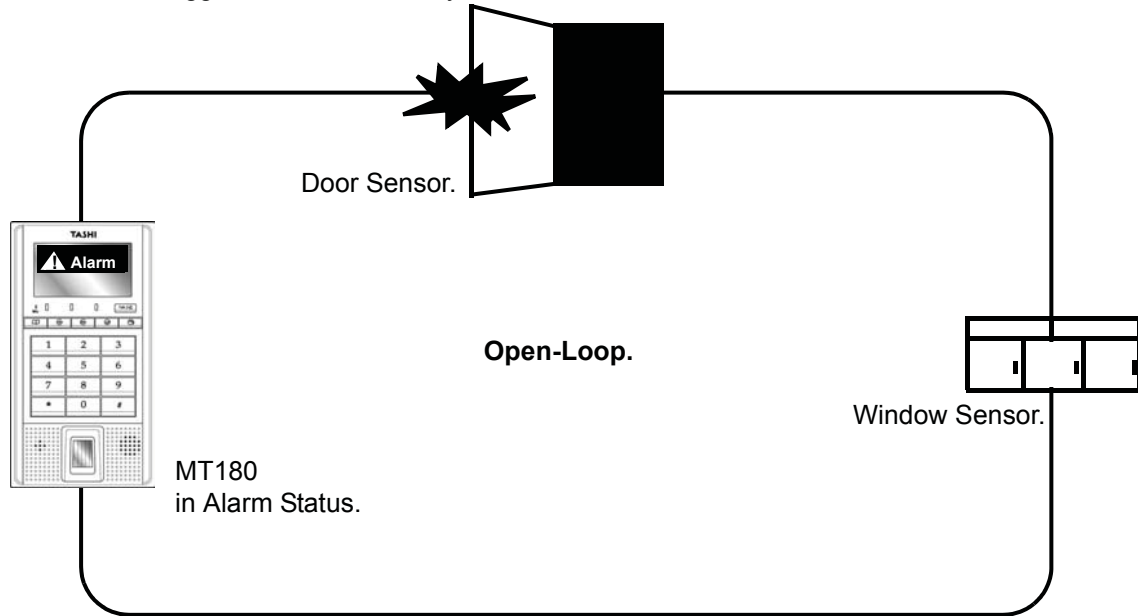

It is possible to place or lift security bars by the same proximity card used for access control or time attendance mode. Utilize MTTool to optimize security settings through the following:

1. Connect Pin 4 (CHECK) to Pin 9 (GND).
2. Connect Pin 5 (SAFE) to Pin 10 (GND).

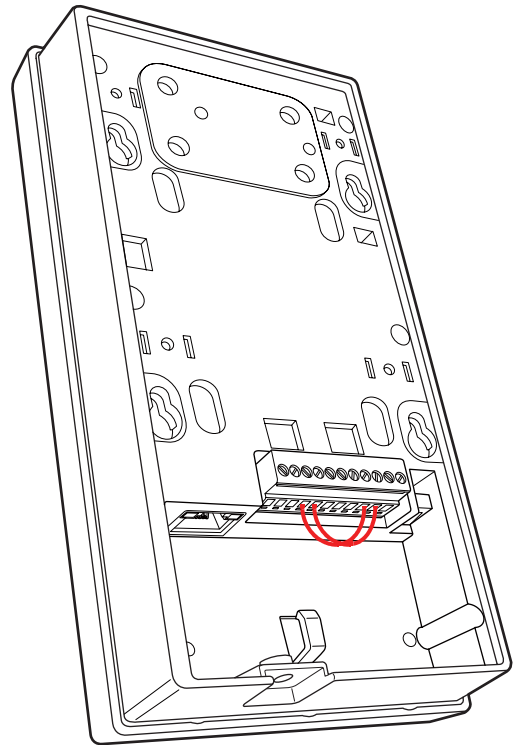

3. Set MT180 and the computer on the same subnet network.
4. Execute MTTool on the computer.

- In MTTool, under the **SysSet1** tab, select **WinSocket** and input the IP address (for example, **192.168.110.230**). Click **Connect**.

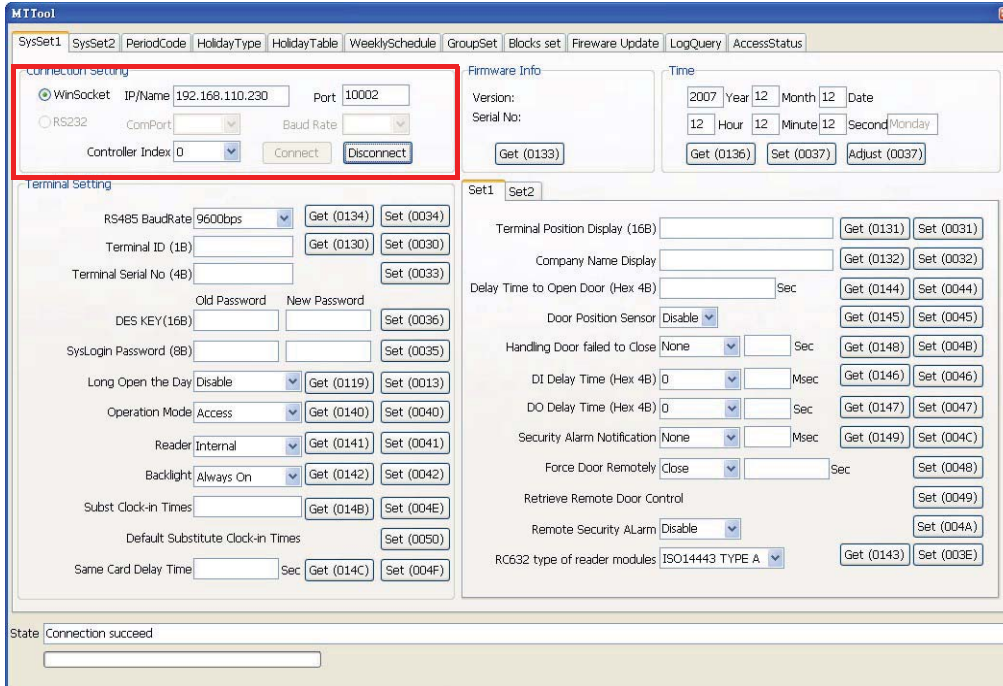

NOTE: See *Advanced Settings* on page 13 to set MT180's IP address.

- Click **Adjust** to synchronize the system time with the computer.

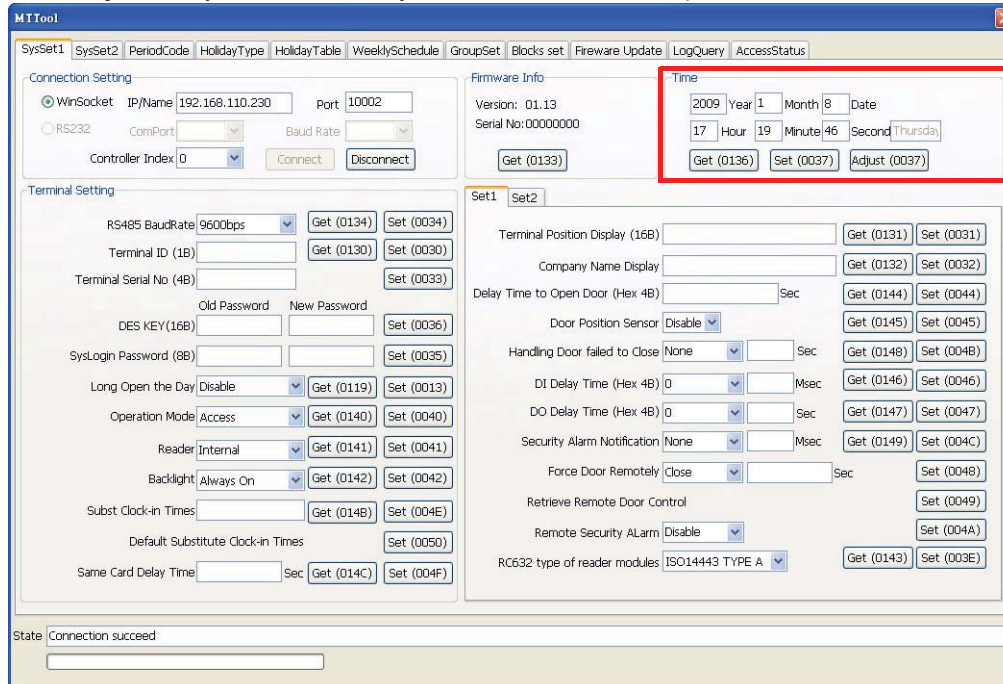

- Click **Get** to double check the date and time set on MT180.

- In the **Set1** tab, select **Buzzer** from the **System Alarm Notification** drop down menu. Click **Set**.

The screenshot shows the MTTool interface with the **Set1** tab selected. The **Terminal Setting** section is visible, and the **Security Alarm Notification** dropdown menu is set to **Buzzer**. The **Set** button is highlighted in red.

- Under the **SysSet2** tab in the **Card Setting** box, input the card number, user name, user number, group number and etc. Click **Add a Card No.**

The screenshot shows the MTTool interface with the **SysSet2** tab selected. The **Card Setting** box is highlighted in red, showing fields for **Card No (8B)**, **User Name (12B)**, **User No (5B)**, **Group No (1B)**, **Password (4B)**, and **Subst Times (1B)**. The **Add a Card No (0009)** button is highlighted in red.

10. Under the **WeeklySchedule** tab, select **Weekly Security Schedule**.

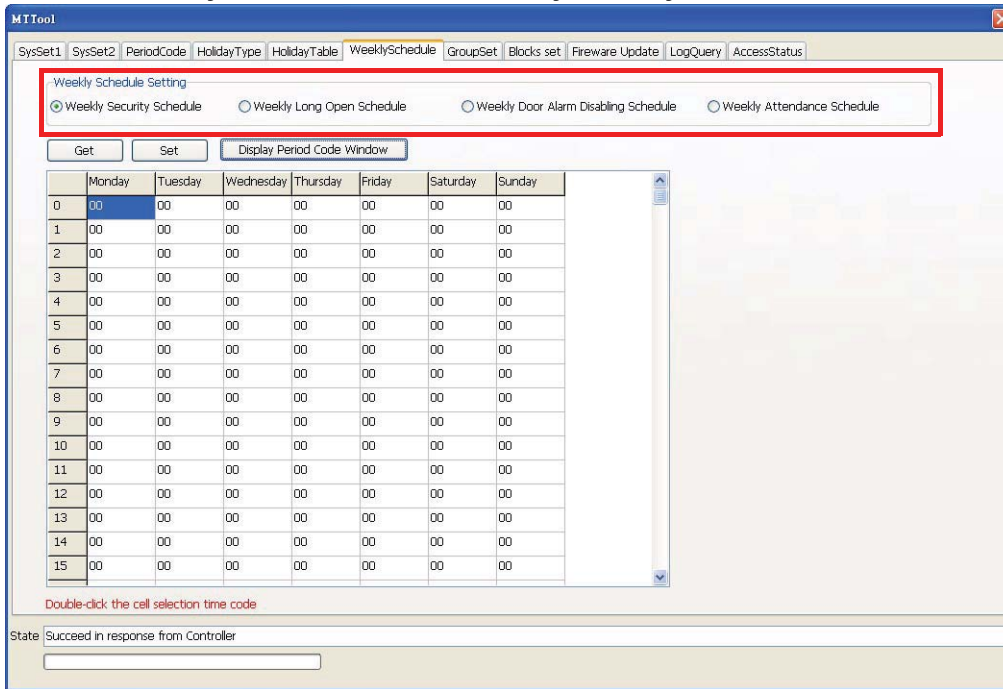

11. Double-click on a desired table cell (for example, **row 1 / column Thursday**). The Period Code window appears.
12. Click a desired time period (for example, **00002359**) to set for 24 hours in this weekday. Click **OK**.

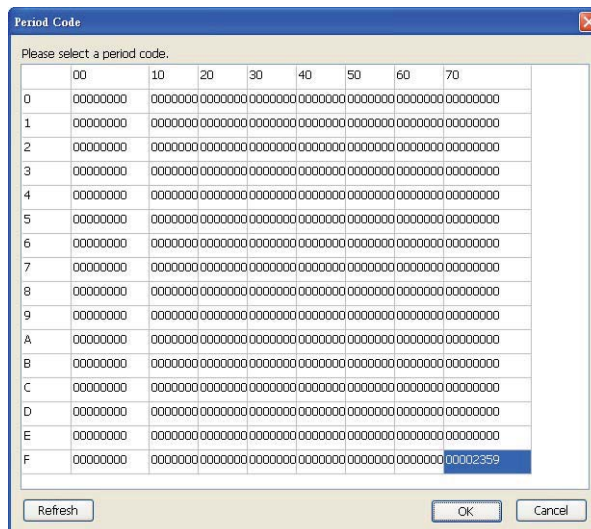

13. The period code **7F** displays on the table cell. Click **Set**.

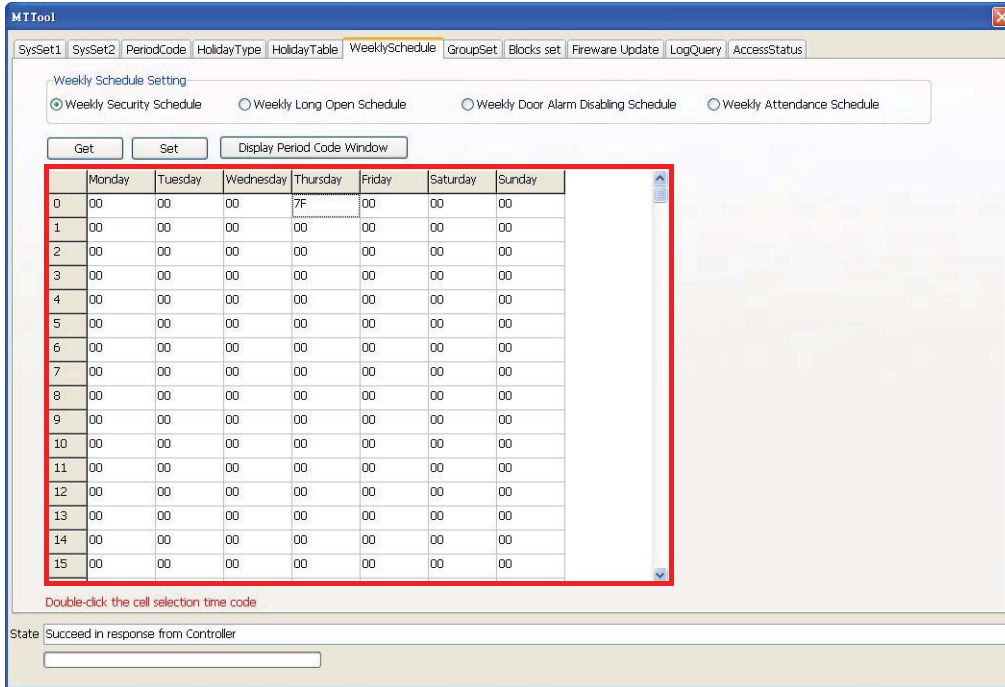

14. Under the **GroupSet** tab, select the desired group (**0**).

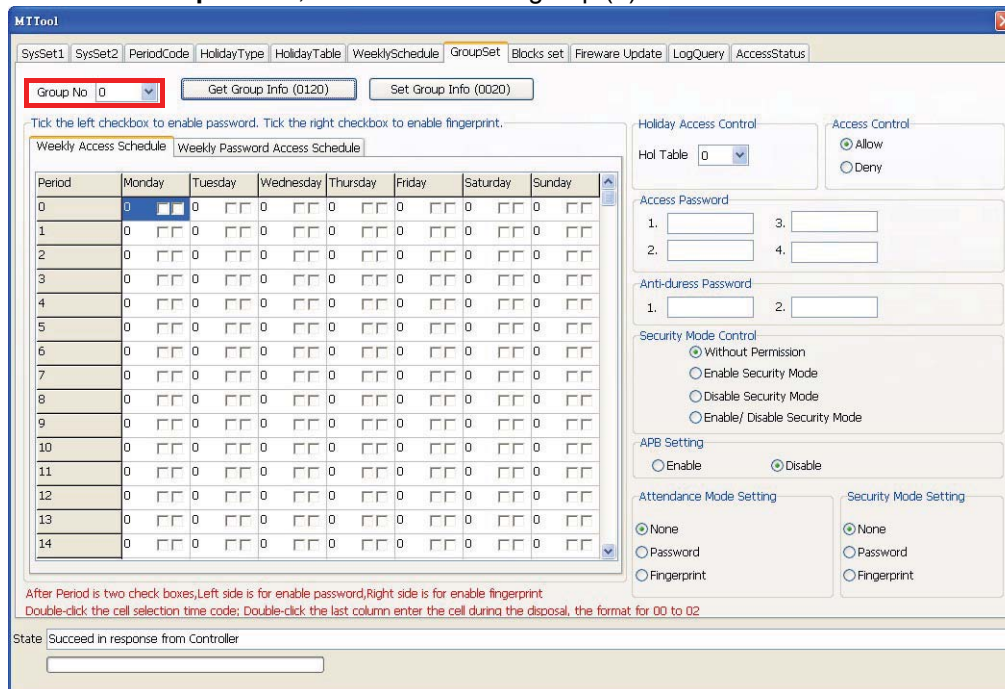

15. Double-click on a desired table cell (**row 1 / column Thursday**). The Period Code window appears.

- Click a desired time period (for example, **00002359**) to set for 24 hours in this weekday. Click **OK**. The period code **7F** displays on the table cell.

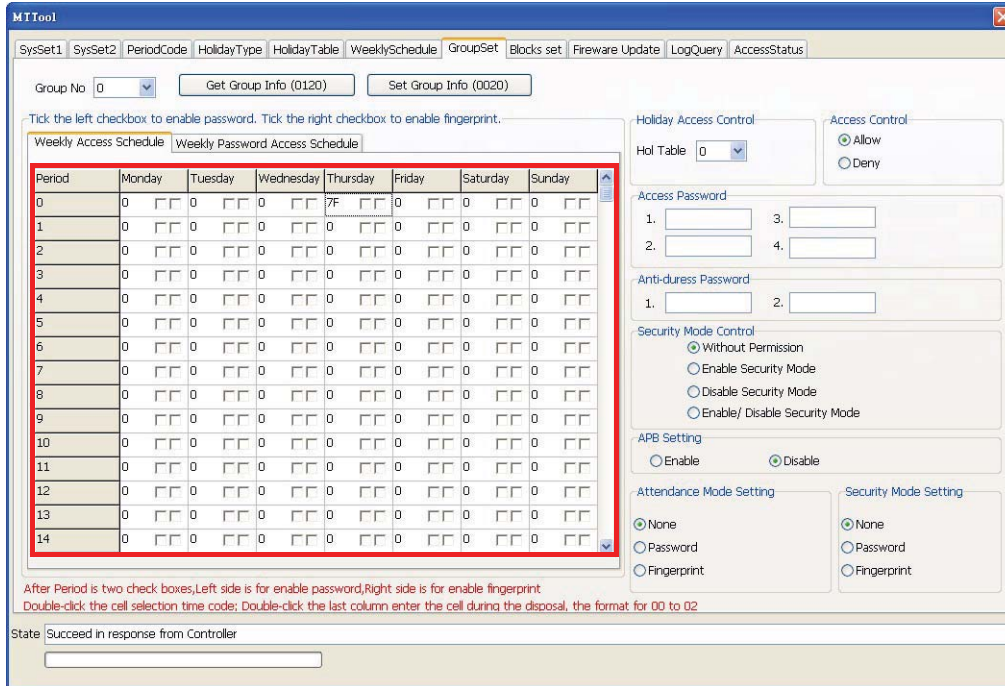

- In the **Security Mode Control** box, select **Enable/ Disable Security Mode**.

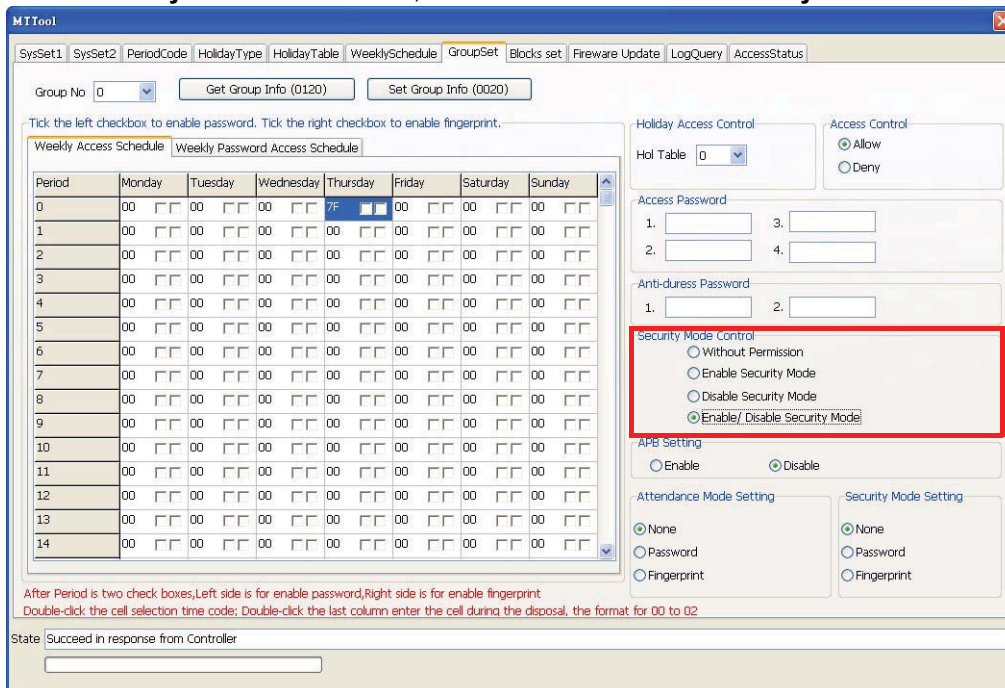

- Click **Set Group Info**.
- Under the **AccessStatus** tab, click **Get Latest Status**.
- Check the **Byte0** box values, **Security Mode** highlights **Enable** in blue.

21. Check the **Byte1** box values, **Door** highlights **Close** in blue, and **Security Trigger** highlights **Close** in blue.

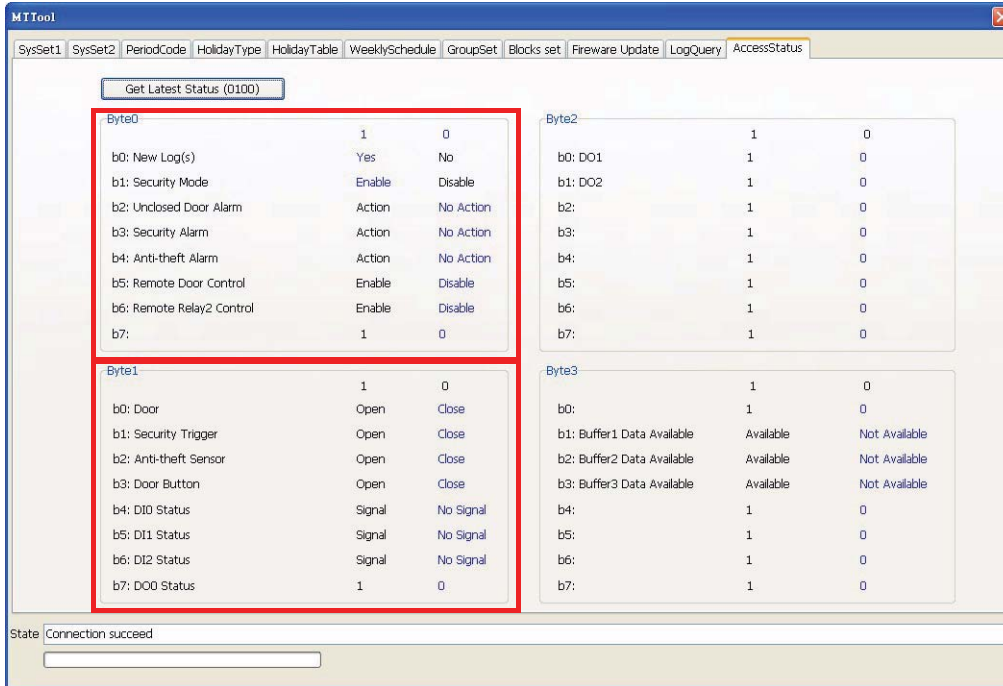

Scenario I - Place Security Ban

Press * to enter the security setting screen, while in standby status. The current security status, **SecuredRelease** displays onscreen.

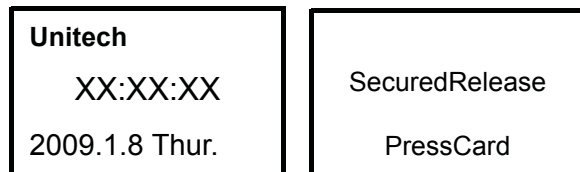

Swipe the card on the Proximity Reader, and the security status switches to **Secured**. **SecuredStatus** displays on the standby screen indicating a security ban.

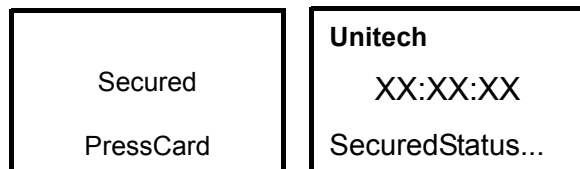

Scenario II - Lift Security Ban

Press * to enter the security setting screen while in standby status and **SecuredStatus** displays onscreen. The current security status, **Secured** displays onscreen.

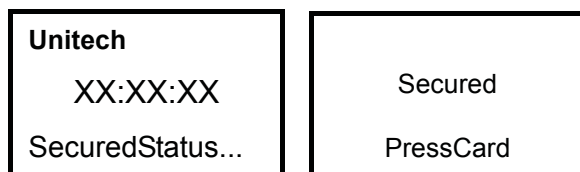

Swipe the card on the Proximity Reader, and the security status switches to **SecuredRelease**. **SecuredStatus** disappears on the standby screen indicating the security ban is lifted.

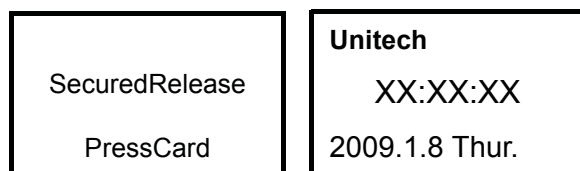

Scenario III - Trigger Security Alarm

Disconnect Pin 5 (SAFE) to Pin 10 (GND) to loosen the loop while the security ban is set. The loosened loop triggers the security alarm, and **SecuredAlarm** displays on the standby screen.

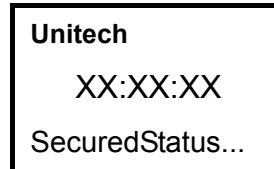

Press * to enter the security setting screen. The current security status, **Secured** displays onscreen. Swipe the card on the Proximity Reader, the security status switches to **SecuredRelease** indicating that the security ban is lifted.

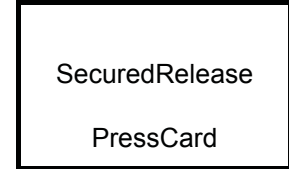
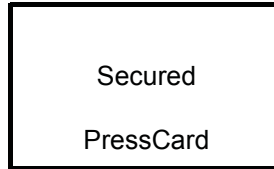

SecuredAlarm disappears on the standby screen. Check the loop and reconnect Pin 5 (SAFE) to Pin 10 (GND).

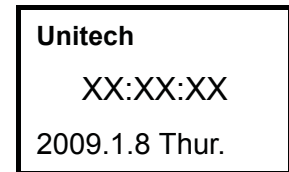

Anti-Pass Back Setting

Enforce Anti-Pass Back to control the entrance/exit behavior and prevent unauthorized access. Utilize MTTool to prohibit same card reentry and re-exit through the same door.

1. Connect a secondary reader to MT180 via RS232 Drive.

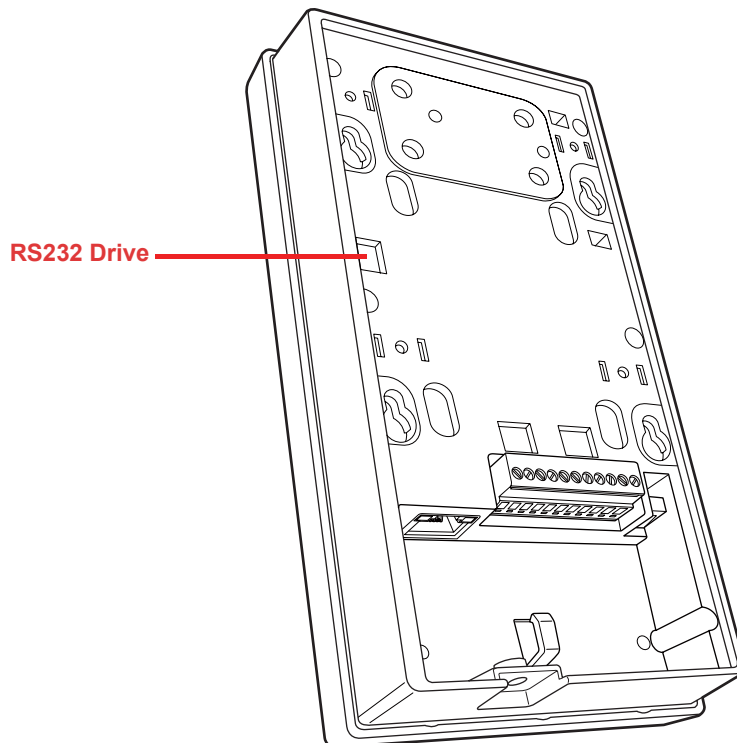

NOTE: While MT180 serves as an internal reader, the secondary reader is the external reader. Ensure the card type is compatible with the internal/external reader.

2. Set MT180 and the computer on the same subnet network.
3. Execute MTTool on the computer.

- In MTTool, under the **SysSet1** tab, select **WinSocket** and input the IP address (for example, **192.168.110.230**). Click **Connect**.

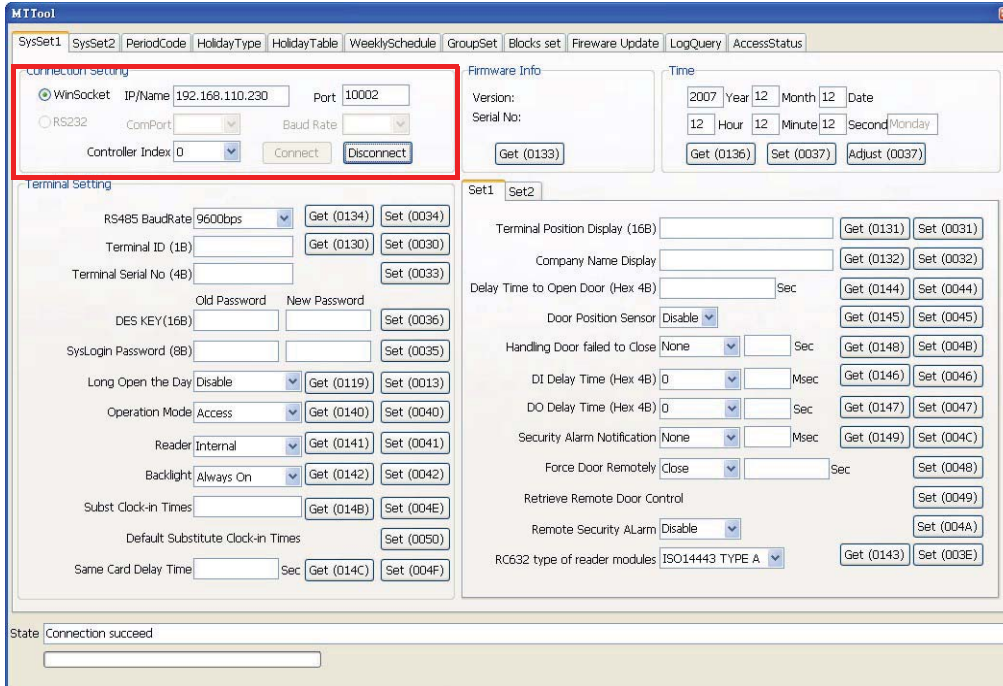

NOTE: See *Advanced Settings* on page 13 to set MT180's IP address.

- Click **Adjust** to synchronize the system time with the computer.

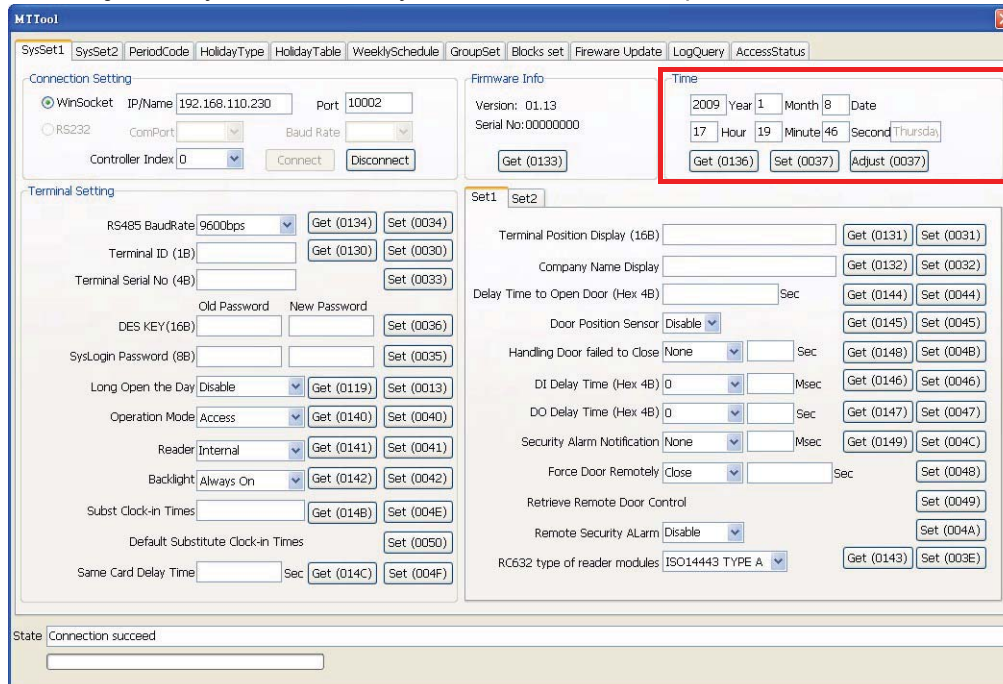

- Click **Get** to double check the date and time set on MT180.

- In the **Terminal Setting** box, select **Internal+External** from the **Reader** drop-down menu. Click **Set**.

The screenshot shows the MTTool software interface with the 'Terminal Setting' tab selected. The 'Reader' dropdown menu is set to 'Internal+External'. The 'Set' button is highlighted. The interface includes various configuration options for the terminal, such as baud rate, terminal ID, and password settings.

- Under the **SysSet2** tab, in the **Card Setting** box, input the card number, user name, user number, group number and etc. Click **Add a Card No.**

The screenshot shows the MTTool software interface with the 'Card Setting' tab selected. The 'Add a Card No.' button is highlighted. The interface includes various configuration options for the card, such as card number, user name, and password settings.

- Under the **GroupSet** tab, select the desired group (**0**).

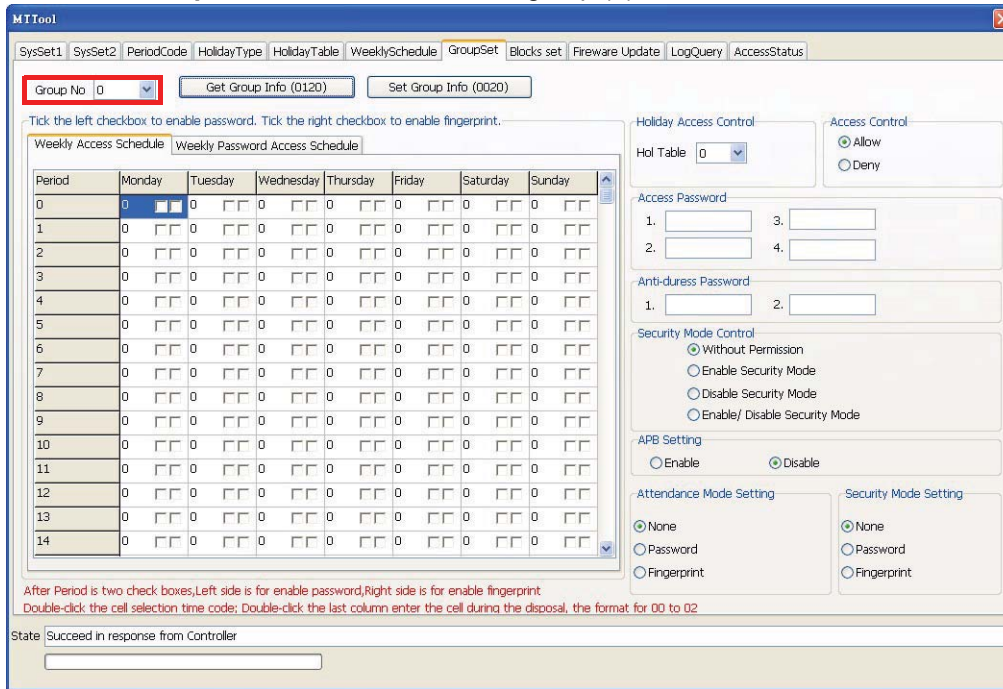

- Double-click on a desired table cell (**row 1 / column Thursday**). The Period Code window appears.
- Click a desired time period (for example, **00002359**) to set for 24 hours of access in this week-day. Click **OK**. The period code **7F** displays on the table cell.

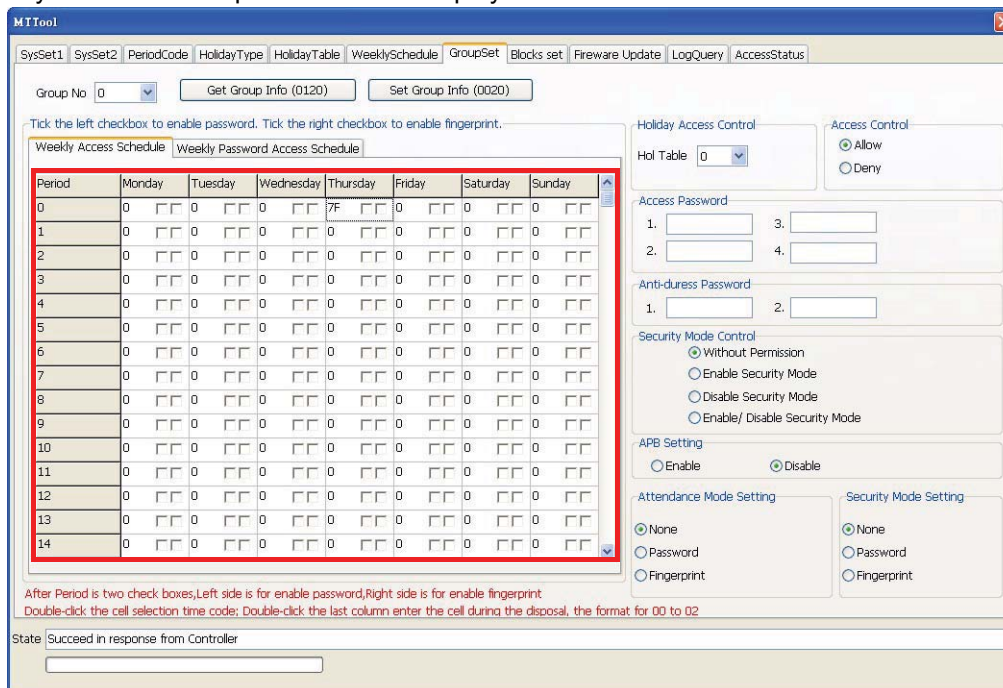

12. In the **APB Setting** box, select **Enable**.

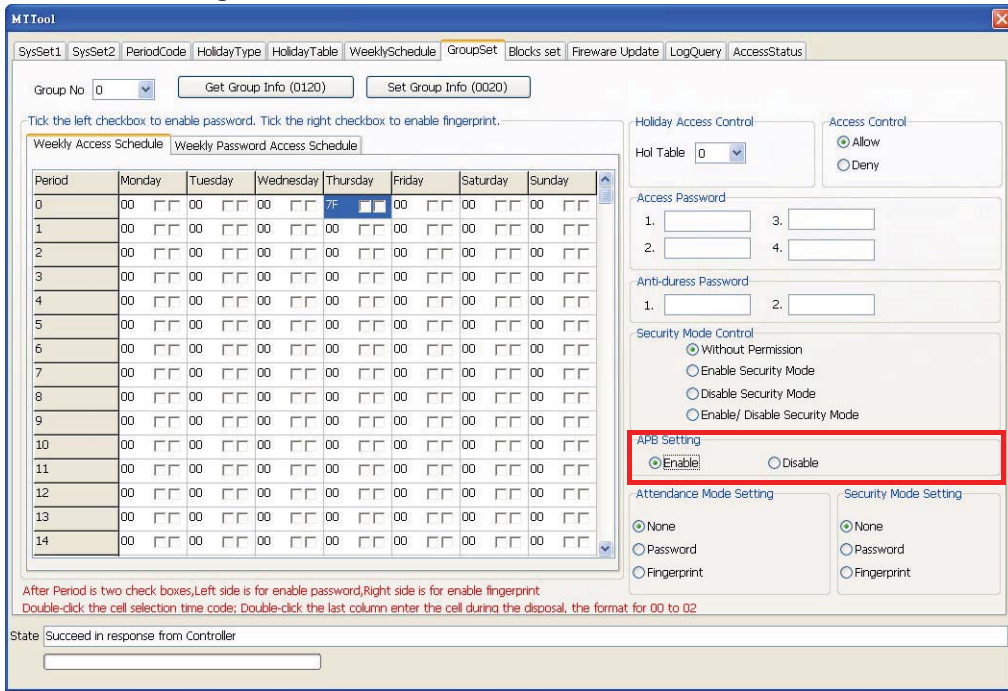

13. Click **Set Group Info**.

Utilize JanitorLite to prohibit same card reentry and re-exit through the same door.

1. Connect a secondary reader to MT180 via Drive RS232.

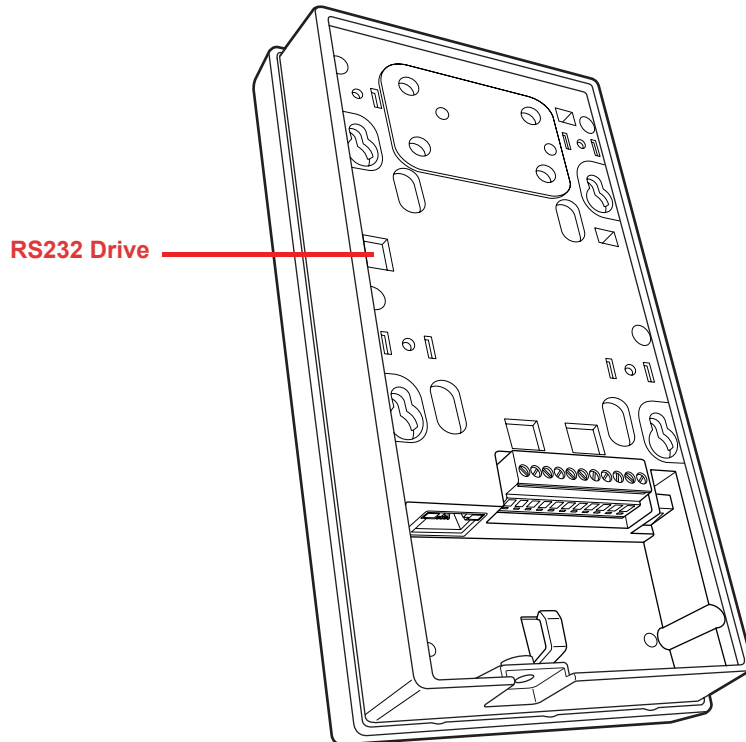

NOTE: While MT180 serves as an internal reader, the secondary reader is the external reader. Ensure the card type is compatible with the internal/external reader.

2. Set MT180 and the computer on the same subnet network.

NOTE: Switch the controller operation mode to be Access, and synchronize the date and time in MTTool.

3. Execute JanitorLite on the computer.
4. Click **Controller(C)** → **Controller Management**.
5. Right-click **All Groups**, and click **Append** → **Group** to add a new controller group. The Controller Group Management window appears.
6. Enter the controller group name (for example, **Demo**). Click **Apply** → **OK** to return to the Controller Group Management window.

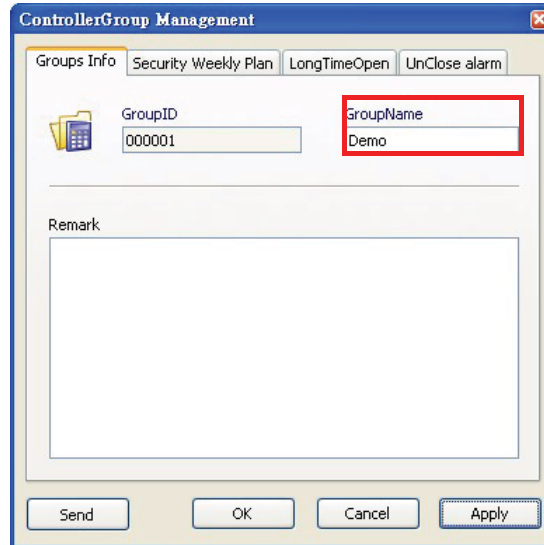

7. Right-click the desired group (**Demo**), and click **Append** → **Entity** to add a new controller. The Controller Management window appears.
8. In the **ControllerName** field, enter the controller name (for example, **MT180**).
9. In the **IPHost** field, input the controller's IP address (**192.168.110.230**). Click **Apply**.

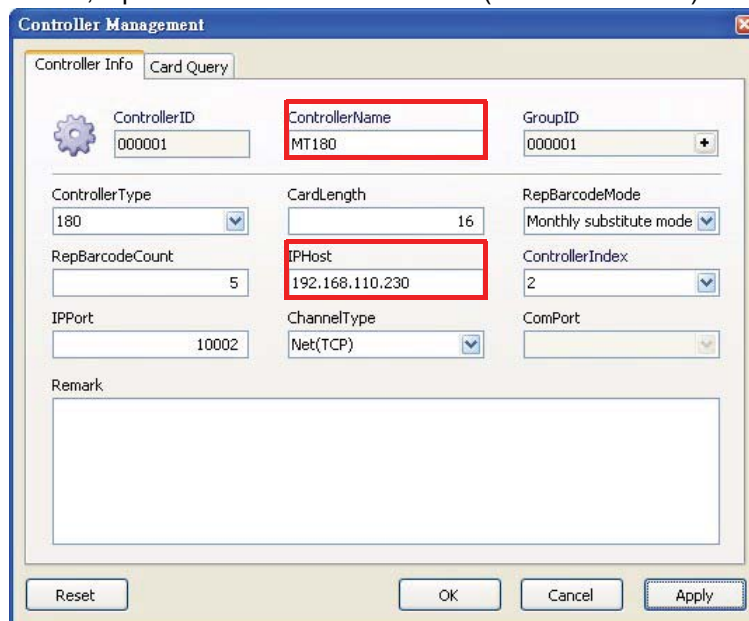

10. Click **Reset** to reset data in this controller. A window appears, asking to reset. Click **Yes**. MT180 screen displays messages **Please wait! EraseFingerInfo.**, **Please wait! Erase Log...** and **Please wait! EraseCardInfo.** MT180 returns to the standby status when complete.

NOTE: Alternatively, reset data under the **SysSet2** tab in MTTTool. In the **Delete all** field, select to delete all cards, logs, fingerprints, and click **Delete**. In the **Shift Setting** field, click **Clear All** → **Set**.

11. Click **OK** to return to the Controller Group Management window.
12. Click **User(U)** → **User Management**.

13. Right-click **All Groups**, and click **Append** → **Group** to add a new user group. The UserGroup Setting window appears.
14. In the **GroupName** field, enter the user group name (**Demo**). Click **Apply** → **OK** to return to the JanitorLite - [Users Management] window.

The screenshot shows a dialog box titled "UserGroup Setting" with a "Group Info" tab. It contains a "GroupID" field with the value "000001" and a "GroupName" field with the value "Demo". The "GroupName" field is highlighted with a red rectangular box. Below these fields is a "Remark" text area. At the bottom of the dialog, there are four buttons: "Send", "OK", "Cancel", and "Apply".

15. Right-click the desired group (**Demo**), and click **Append** → **Entity** to add a new user. The User Setting window appears.
16. In the **UserName** field, enter the user name (for example, **APB**).

The screenshot shows a dialog box titled "User setting" with a "User Info" tab. It contains a "UserID" field with the value "0000000001" and a "UserName" field with the value "APB". The "UserName" field is highlighted with a red rectangular box. To the right of the "UserName" field are radio buttons for "Male" (selected) and "Female". Below these are fields for "CardNo", "CardKey" (value: 12345678), "GroupID" (value: 000001), "GroupNo", "ID No.", "E-Mail", "Mobile", "Telephone", "Address", and "Account". A "Remark" text area is at the bottom. At the bottom of the dialog, there are four buttons: "FingerPrint", "OK", "Cancel", and "Apply".

17. Inside the **CardNo** field, click **+**. The Card setting window appears.

18. Input the card number in the **Card No.** field. Click **Apply** → **OK** to return to the User setting window.

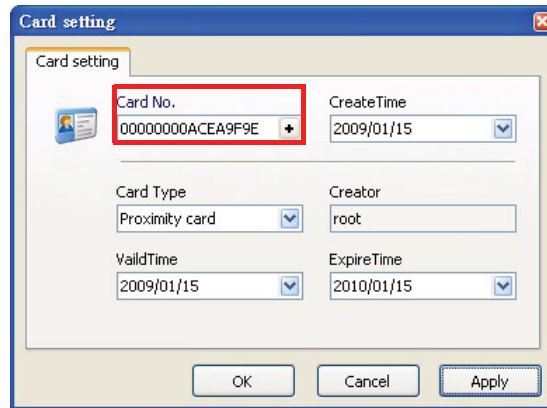

NOTE: See *General Settings* on page 12 to acquire the card number.

19. Click **OK** to return to the JanitorLite - [Users Management] window.
20. Click **Permit(P)** → **Permit Management**.
21. Select the desired user group (**Demo**), and click **Setting** on the toolbar. The Selected Controllers window appears.
22. Select the desired controllers (**MT180** and **Demo**), and click **OK** to return to the JanitorLite - [Permit Management] window.

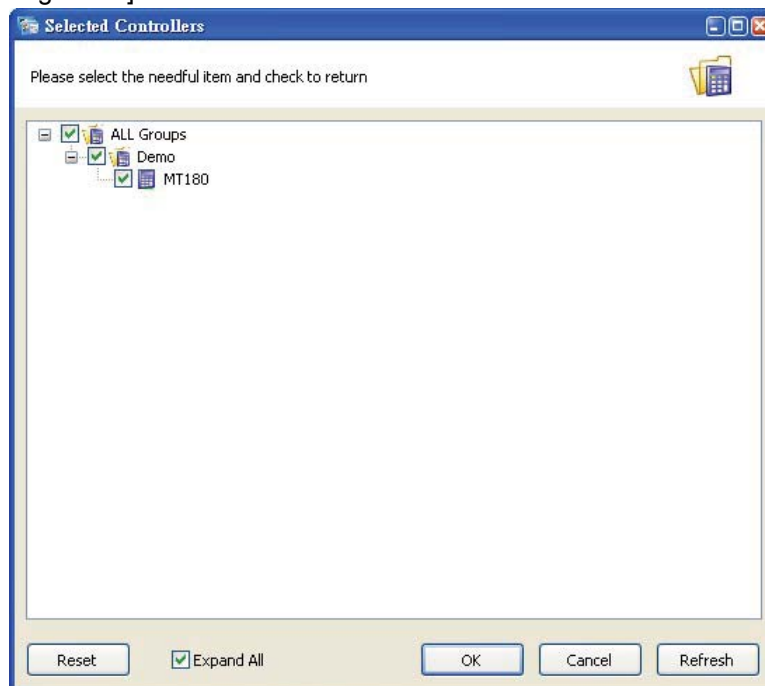

23. Double-click the desired user group (**Demo**). The UserGroup Setting window appears.

- Under the **Permit Setting** tab, check **Anti-back**. Click **Apply** → **Send** to immediately send this command to the controller. A window appears with the message **Setting Successfully**.

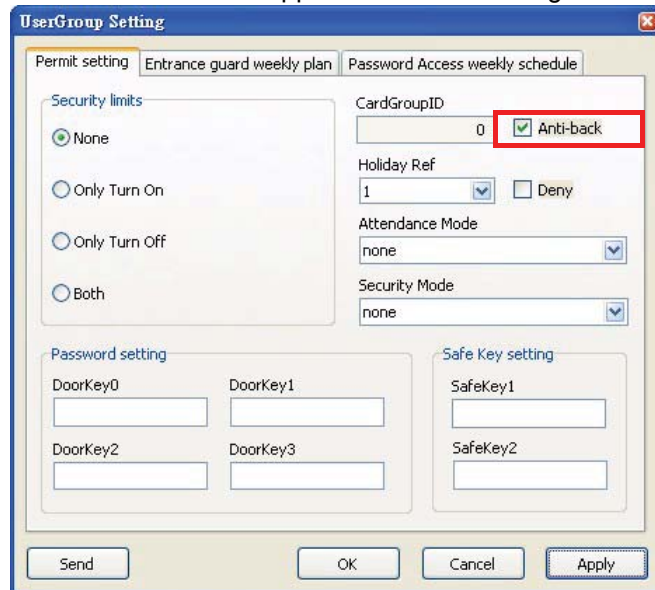

- Under the **Entrance guard weekly plan** tab, select a desired weekday from the drop down menu.
- Inside the **PeriodID** field, double-click **+**. The Selected periods window appears.
- Click a desired time period (for example, PeriodID **127**) to set for 24 hours of access in this weekday, and click **OK**.

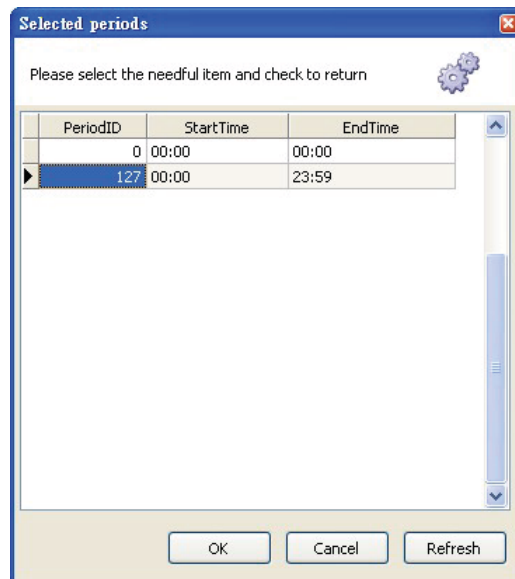

28. Click **Apply** → **Send** to send the command to the controller immediately.

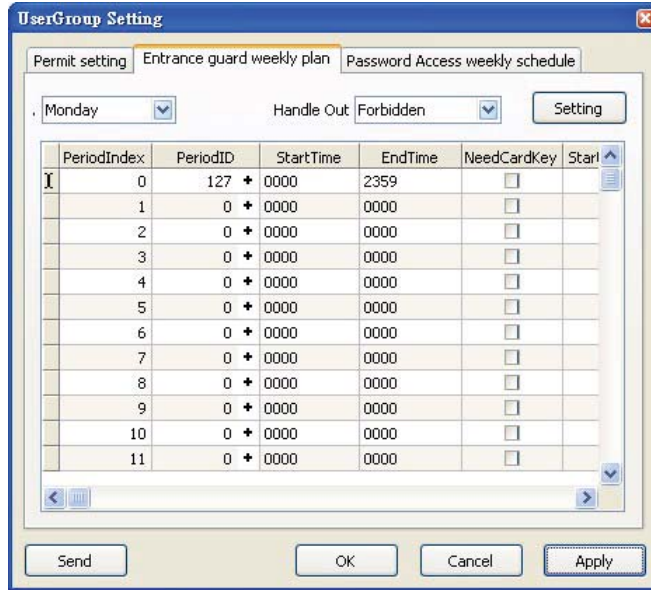

29. Click **OK** to return to the JanitorLite - [Permit Management] window.

Scenario I - Normal Entrance and Exit

Swipe the card on the internal reader, while in standby status. **Entrance** with the user name **APB** displays on the standby screen indicating that reentry is not allowed.

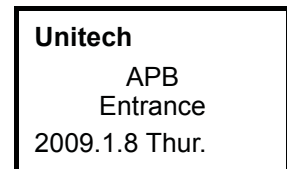

Swipe the card on the external reader, **Exit** with the user name **APB** displays on the standby screen indicating that re-exiting is not allowed.

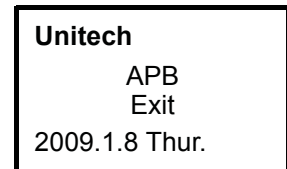

Scenario II - Re-Entering

Swipe the card on the internal reader, **Entrance** with the user name **APB** displays on the standby screen.

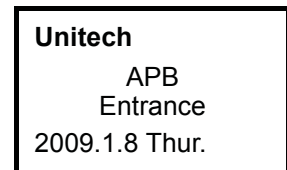

Swipe the card again on the internal reader, **Re-Entering** with the user name **APB** displays on the standby screen indicating that reentry occurred.

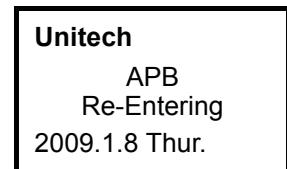

Scenario III - Re-Exiting

Swipe the card on the external reader, **Exit** with the user name **APB** displays on the standby screen.

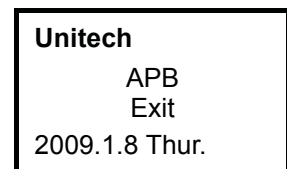

Swipe the card again on the external reader, **Re-Exiting** with the user name **APB** displays on the standby screen indicating that re-exiting occurred.

Unitech
 APB
 Re-Exiting
 2009.1.8 Thur.

If utilizing JanitorLite, Click **Report(R)** → **Access Report**. Under the **Conditions** tab, filter the user, controller, and date, and click **OK**. The access record displays under the Preview tab.

LogDate	ControllerID	ControllerName	GroupID	UserID	UserName	GroupID	CardNo	AccessTime	StateDescription
20090119	000001	MT180	000001	0000000001	APB	000001	00000000ACEA9F9E	1/19/2009 2:12:49 PM	Entry check
20090119	000001	MT180	000001	0000000001	APB	000001	00000000ACEA9F9E	1/19/2009 2:12:51 PM	Egress check
20090119	000001	MT180	000001	0000000001	APB	000001	00000000ACEA9F9E	1/19/2009 2:12:53 PM	Entry check
20090119	000001	MT180	000001	0000000001	APB	000001	00000000ACEA9F9E	1/19/2009 2:12:53 PM	Re-enter
20090119	000001	MT180	000001	0000000001	APB	000001	00000000ACEA9F9E	1/19/2009 2:12:55 PM	Egress check
20090119	000001	MT180	000001	0000000001	APB	000001	00000000ACEA9F9E	1/19/2009 2:12:56 PM	Re-go out
20090119	000001	MT180	000001	0000000001	APB	000001	00000000ACEA9F9E	1/19/2009 2:13:12 PM	Entry check
20090119	000001	MT180	000001	0000000001	APB	000001	00000000ACEA9F9E	1/19/2009 2:13:13 PM	Egress check
20090119	000001	MT180	000001	0000000001	APB	000001	00000000ACEA9F9E	1/19/2009 2:13:29 PM	Entry check
20090119	000001	MT180	000001	0000000001	APB	000001	00000000ACEA9F9E	1/19/2009 4:10:03 PM	Entry check
20090119	000001	MT180	000001	0000000001	APB	000001	00000000ACEA9F9E	1/19/2009 4:10:11 PM	Re-enter
20090119	000001	MT180	000001	0000000001	APB	000001	00000000ACEA9F9E	1/19/2009 4:10:17 PM	Egress check
20090119	000001	MT180	000001	0000000001	APB	000001	00000000ACEA9F9E	1/19/2009 4:10:19 PM	Re-go out
20090119	000001	MT180	000001	0000000001	APB	000001	00000000ACEA9F9E	1/19/2009 4:10:23 PM	Entry check
20090119	000001	MT180	000001	0000000001	APB	000001	00000000ACEA9F9E	1/19/2009 4:10:24 PM	Egress check
20090119	000001	MT180	000001	0000000001	APB	000001	00000000ACEA9F9E	1/19/2009 4:10:25 PM	Re-go out
20090119	000001	MT180	000001	0000000001	APB	000001	00000000ACEA9F9E	1/19/2009 4:10:26 PM	Entry check
20090119	000001	MT180	000001	0000000001	APB	000001	00000000ACEA9F9E	1/19/2009 4:10:27 PM	Egress check
20090119	000001	MT180	000001	0000000001	APB	000001	00000000ACEA9F9E	1/19/2009 4:10:33 PM	Entry check
20090119	000001	MT180	000001	0000000001	APB	000001	00000000ACEA9F9E	1/19/2009 4:10:34 PM	Egress check
20090119	000001	MT180	000001	0000000001	APB	000001	00000000ACEA9F9E	1/19/2009 4:10:35 PM	Entry check
20090119	000001	MT180	000001	0000000001	APB	000001	00000000ACEA9F9E	1/19/2009 4:10:36 PM	Re-enter
20090119	000001	MT180	000001	0000000001	APB	000001	00000000ACEA9F9E	1/19/2009 4:10:37 PM	Egress check

Appendix A

System Specification

Processing/Memory	CPU	ARM7TDMI-S
	Memory	8MB External Flash
Display	128 × 64 Pixel COG/FSTN LCD with White Backlight	
Keypad	18-key, Including Talk Key, Function Key and Numeric Key	
Communication	Ethernet10/100M, RS485 and Optional DECT Voice	
I/O	Digital Inputs (3): Door Open, Door Position and Security Trigger Relay (2): Electrical Door Lock and Alarm	
I/O Expansion	RS232 Drive (1) - Secondary Reader Digital Inputs (3) Digital Outputs (3)	
Proximity Reader (Optional)	EM, 125kHz HID, 125kHz MiFare, 13.56MHz (ISO 14443A/B, ISO 15693)	
Power Supply	DC 12V, 2.0A	
Enclosure	Weight	410 g. (14.46 oz.)
	Dimension	188.09mmL X 38.67mmH X 99.94mmW (7.4"L X 1.5"H X 3.9"W)
Environmental	Operating Temperature	-10°C - 50°C (14°F - 122°F)
	Storage Temperature	-20°C - 60°C (-4°F - 140°F)
	Relative Humidity	35% - 95%
Certification	CE, FCC, NCC, CCC, RoHS compliant	
Software	JanitorLite, MTTool, Communication SDK	
Accessories	On Wall Mounting Kit	

Appendix B

Worldwide Support

Region	Website
Global Operation Center	www.unitech-adc.com
Unitech Asia Pacific & Middle	www.unitech-utp.com.tw
Greater China Division	www.unitech-sbd.com
Unitech Japan	www.unitech-japan.co.jp
Unitech America	www.ute.com
Unitech Latin America	www.latin.ute.com
Unitech Europe	www.unitech-europe.nl