

## FCC Test Report (ENDC: n71 + LTE B2/B66)

**Report No.:** RFBCKT-WTW-P22010886-13

**FCC ID:** HFSQTAD53N

**Test Model:** QTAD53

**Received Date:** Feb. 10, 2022

**Test Date:** Feb. 27 ~ Mar. 06, 2022

**Issued Date:** Mar. 30, 2022

**Applicant:** Quanta Computer Inc.

**Address:** NO. 188, Wenhua 2nd Rd., Guishan Dist., Taoyuan City 33377, Taiwan  
(R.O.C)

**Issued By:** Bureau Veritas Consumer Products Services (H.K.) Ltd., Taoyuan Branch  
Lin Kou Laboratories

**Lab Address:** No. 47-2, 14th Ling, Chia Pau Vil., Lin Kou Dist., New Taipei City, Taiwan

**Test Location:** No. 19, Hwa Ya 2nd Rd., Wen Hwa Vil., Kwei Shan Dist., Taoyuan City  
33383, Taiwan

**FCC Registration /  
Designation Number:** 788550 / TW0003



This report is for your exclusive use. Any copying or replication of this report to or for any other person or entity, or use of our name or trademark, is permitted only with our prior written permission. This report sets forth our findings solely with respect to the test samples identified herein. The results set forth in this report are not indicative or representative of the quality or characteristics of the lot from which a test sample was taken or any similar or identical product unless specifically and expressly noted. Our report includes all of the tests requested by you and the results thereof based upon the information that you provided to us. You have 60 days from date of issuance of this report to notify us of any material error or omission caused by our negligence, provided, however, that such notice shall be in writing and shall specifically address the issue you wish to raise. A failure to raise such issue within the prescribed time shall constitute your unqualified acceptance of the completeness of this report, the tests conducted and the correctness of the report contents. Unless specific mention, the uncertainty of measurement has been explicitly taken into account to declare the compliance or non-compliance to the specification.

## Table of Contents

<b>Release Control Record</b> .....	<b>4</b>
<b>1 Certificate of Conformity</b> .....	<b>5</b>
<b>2 Summary of Test Results</b> .....	<b>6</b>
2.1 Measurement Uncertainty.....	8
2.2 Test Site and Instruments.....	9
<b>3 General Information</b> .....	<b>9</b>
3.1 General Description of EUT.....	10
3.2 Configuration of System under Test.....	13
3.2.1 Description of Support Units.....	13
3.3 Test Mode Applicability and Tested Channel Detail.....	14
3.4 EUT Operating Conditions.....	21
3.5 General Description of Applied Standards and References.....	21
<b>4 Test Types and Results</b> .....	<b>22</b>
4.1 Output Power Measurement.....	22
4.1.1 Limits of Output Power Measurement.....	22
4.1.2 Test Procedures.....	22
4.1.3 Test Setup.....	22
4.1.4 Test Results.....	23
4.2 Modulation Characteristics Measurement.....	51
4.2.1 Limits of Modulation Characteristics.....	51
4.2.2 Test Procedure.....	51
4.2.3 Test Setup.....	51
4.2.4 Test Results.....	52
4.3 Frequency Stability Measurement.....	53
4.3.1 Limits of Frequency Stability Measurement.....	53
4.3.2 Test Procedure.....	53
4.3.3 Test Setup.....	53
4.3.4 Test Results.....	54
4.4 Occupied Bandwidth Measurement.....	58
4.4.1 Limits of Occupied Bandwidth Measurement.....	58
4.4.2 Test Procedure.....	58
4.4.3 Test Setup.....	58
4.4.4 Test Result.....	59
4.5 Band Edge Measurement.....	63
4.5.1 Limits of Band Edge Measurement.....	63
4.5.2 Test Setup.....	63
4.5.3 Test Procedures.....	63
4.5.4 Test Results.....	64
4.6 Peak to Average Ratio.....	68
4.6.1 Limits of Peak to Average Ratio Measurement.....	68
4.6.2 Test Setup.....	68
4.6.3 Test Procedures.....	68
4.6.4 Test Results.....	69
4.7 Conducted Spurious Emissions.....	71
4.7.1 Limits of Conducted Spurious Emissions Measurement.....	71
4.7.2 Test Setup.....	71
4.7.3 Test Procedure.....	71
4.7.4 Test Results.....	72
4.8 Radiated Emission Measurement.....	76
4.8.1 Limits of Radiated Emission Measurement.....	76
4.8.2 Test Procedure.....	76
4.8.3 Deviation from Test Standard.....	76
4.8.4 Test Setup.....	77

4.8.5 Test Results .....	78
<b>5 Pictures of Test Arrangements.....</b>	<b>100</b>
<b>Appendix – Information of the Testing Laboratories .....</b>	<b>101</b>

### Release Control Record

Issue No.	Description	Date Issued
RFBCKT-WTW-P22010886-13	Original release	Mar. 30, 2022

## 1 Certificate of Conformity

**Product:** 5G Hotspot

**Brand:** T-Mobile

**Test Model:** QTAD53

**Sample Status:** Engineering sample

**Applicant:** Quanta Computer Inc.

**Test Date:** Feb. 27 ~ Mar. 06, 2022

**Standards:** FCC Part 24, Subpart E  
FCC Part 27, Subpart C, L, N

The above equipment has been tested by **Bureau Veritas Consumer Products Services (H.K.) Ltd., Taoyuan Branch**, and found compliance with the requirement of the above standards. The test record, data evaluation & Equipment Under Test (EUT) configurations represented herein are true and accurate accounts of the measurements of the sample's RF characteristics under the conditions specified in this report.

**Prepared by :** Pettie Chen, **Date:** Mar. 30, 2022  
Pettie Chen / Senior Specialist

**Approved by :** Jeremy Lin, **Date:** Mar. 30, 2022  
Jeremy Lin / Project Engineer

## 2 Summary of Test Results

For n71

Applied Standard: FCC Part 27 & Part 2			
FCC Clause	Test Item	Result	Remarks
2.1046 27.50 (c)	Equivalent Radiated Power	Pass	Meet the requirement of limit.
2.1047	Modulation Characteristics	Pass	Meet the requirement of limit.
----	Peak To Average Ratio	Pass	Meet the requirement of limit.
2.1055 27.54	Frequency Stability Stay with the authorized bands of operation	Pass	Meet the requirement of limit.
2.1049	Occupied Bandwidth	Pass	Meet the requirement of limit.
2.1051 27.53 (g)	Band Edge Measurements	Pass	Meet the requirement of limit.
2.1051 27.53 (g)	Conducted Spurious Emissions	Pass	Meet the requirement of limit.
2.1053 27.53 (g)	Radiated Spurious Emissions	Pass	Meet the requirement of limit. Minimum passing margin is -38.97dB at 773.02, 992.24MHz.

Note: Determining compliance based on the results of the compliance measurement, not taking into account measurement instrumentation uncertainty.

For LTE Band 2

Applied Standard: FCC Part 24 & Part 2			
FCC Clause	Test Item	Result	Remarks
2.1046 24.232	Effective Isotropically Radiated Power	Pass	Meet the requirement of limit.
2.1046 24.232 (d)	Peak To Average Ratio	Pass	Refer to Note 1
2.1047	Modulation Characteristics	Pass	Refer to Note 1
2.1055 24.235	Frequency Stability	Pass	Refer to Note 1
2.1049	Occupied Bandwidth	Pass	Refer to Note 1
24.238	Band Edge Measurements	Pass	Refer to Note 1
2.1051 24.238	Conducted Spurious Emissions	Pass	Refer to Note 1
2.1053 24.238	Radiated Spurious Emissions	Pass	Meet the requirement of limit. Minimum passing margin is -32.13dB at 3800.00MHz.

Note:

1. This report is a partial report. Therefore, only test item of Transmitter Output Power and Equivalent Isotropically Radiated Power and Radiated Spurious Emissions tests were performed for this report. Other testing data please refer to BV CPS report no.: RFBCKT-WTW-P22010886-4.
2. Determining compliance based on the results of the compliance measurement, not taking into account measurement instrumentation uncertainty.

For LTE Band 66

Applied Standard: FCC Part 27 & Part 2			
FCC Clause	Test Item	Result	Remarks
2.1046 27.50 (d)(4)	Equivalent Isotropically Radiated Power	Pass	Meet the requirement of limit.
2.1047	Modulation Characteristics	Pass	Refer to Note 1
27.50 (d)(5)	Peak To Average Ratio	Pass	Refer to Note 1
2.1055 27.54	Frequency Stability Stay with the authorized bands of operation	Pass	Refer to Note 1
2.1049	Occupied Bandwidth	Pass	Refer to Note 1
2.1051 27.53 (h)	Band Edge / Out of Band Emissions Measurements	Pass	Refer to Note 1
2.1051 27.53 (h)	Conducted Spurious Emissions	Pass	Refer to Note 1
2.1053 27.53 (h)	Radiated Spurious Emissions	Pass	Meet the requirement of limit. Minimum passing margin is -33.39dB at 3540.00MHz.

Note:

1. This report is a partial report. Therefore, only test item of Transmitter Output Power and Equivalent Isotropically Radiated Power and Radiated Spurious Emissions tests were performed for this report. Other testing data please refer to BV CPS report no.: RFBCKT-WTW-P22010886-5.
2. Determining compliance based on the results of the compliance measurement, not taking into account measurement instrumentation uncertainty.

## 2.1 Measurement Uncertainty

Where relevant, the following measurement uncertainty levels have been estimated for tests performed on the EUT as specified in CISPR 16-4-2:

Measurement	Frequency	Expanded Uncertainty (k=2) ( $\pm$ )
Radiated Emissions up to 1 GHz	9kHz ~ 30MHz	3.04 dB
	30MHz ~ 200MHz	3.86 dB
	200MHz ~ 1000MHz	3.87 dB
Radiated Emissions above 1 GHz	1GHz ~ 18GHz	2.29 dB
	18GHz ~ 40GHz	2.29 dB



## 2.2 Test Site and Instruments

Description & Manufacturer	Model No.	Serial No.	Cal. Date	Cal. Due
Test Receiver KEYSIGHT	N9038A	MY55420137	Apr. 09, 2021	Apr. 08, 2022
Spectrum Analyzer ROHDE & SCHWARZ	FSP40	100039	Jun. 10, 2021	Jun. 09, 2022
MXG Vector signal generator Agilent	N5182B	MY53050430	Nov. 25, 2021	Nov. 24, 2022
Radio Communication Analyzer Anritsu	MT8821C	6261806803	Feb. 16, 2022	Feb. 15, 2023
BILOG Antenna SCHWARZBECK	VULB9168	9168-160	Oct. 28, 2021	Oct. 27, 2022
HORN Antenna SCHWARZBECK	BBHA 9120 D	9120D-1169	Nov. 14, 2021	Nov. 13, 2022
HORN Antenna SCHWARZBECK	BBHA 9170	BBHA9170241	Oct. 26, 2021	Oct. 25, 2022
Loop Antenna TESEQ	HLA 6121	45745	Jul. 21, 2021	Jul. 20, 2022
Preamplifier Agilent (Below 1GHz)	8447D	2944A10638	Jun. 05, 2021	Jun. 04, 2022
Preamplifier Agilent (Above 1GHz)	8449B	3008A01887	Feb. 17, 2022	Feb. 16, 2023
RF signal cable HUBER+SUHNER&EMCI	SUCOFLEX 104 & EMC104-SM- SM8000	CABLE-CH9-02 (248780+171006)	Jan. 15, 2022	Jan. 14, 2023
RF signal cable HUBER+SUHNER	SUCOFLEX 104	CABLE-CH9- (250795/4)	Jan. 15, 2022	Jan. 14, 2023
RF signal cable Woken	8D-FB	Cable-CH9-01	Jun. 05, 2021	Jun. 04, 2022
Software BV ADT	ADT_Radiated_ V7.6.15.9.5	NA	NA	NA
Antenna Tower & Turn BV ADT	AT100	AT93021705	NA	NA
Turn Table BV ADT	TT100	TT93021705	NA	NA
Turn Table Controller BV ADT	SC100	SC93021705	NA	NA
Boresight Antenna Fixture	FBA-01	FBA-SIP01	NA	NA
Standard Temperature And Humidity Chamber GIANT FORCE	GTH-120-40-CP-AR	MAA1306-019	Sep. 10, 2021	Sep. 09, 2022
JFW 20dB attenuation	50HF-020-SMA	NA	NA	NA
True RMS Clamp Meter Fluke	325	31130711WS	Jun. 02, 2021	Jun. 01, 2022
DC power supply Keysight	U8002A	MY56330015	NA	NA

Note: 1. The calibration interval of the above test instruments is 12 months and the calibrations are traceable to NML/ROC and NIST/USA.  
2. The test was performed in HwaYa Chamber 9.

### 3 General Information

#### 3.1 General Description of EUT

Product	5G Hotspot
Brand	T-Mobile
Test Model	QTAD53
Sample Status	Engineering sample
Power Supply	5Vdc / 9Vdc / 12Vdc (Adapter)
Rating	3.85Vdc (Battery)

#### n71

Modulation Type	$\pi/2$ BPSK, QPSK, 16QAM, 64QAM, 256QAM					
Waveform Type	CP-OFDM, DFT-s-OFDM					
Operating Frequency	n71 (Channel Bandwidth 5MHz)	665.5MHz ~ 695.5MHz				
	n71 (Channel Bandwidth 10MHz)	668.0MHz ~ 693.0MHz				
	n71 (Channel Bandwidth 15MHz)	670.5MHz ~ 690.5MHz				
	n71 (Channel Bandwidth 20MHz)	673.0MHz ~ 688.0MHz				
Max. ERP Power		$\pi/2$ BPSK	QPSK	16QAM	64QAM	256QAM
	n71 (Channel Bandwidth 5MHz)	186.638mW (22.71dBm)	185.353mW (22.68dBm)	143.219mW (21.56dBm)	90.782mW (19.58dBm)	65.766mW (18.18dBm)
	n71 (Channel Bandwidth 10MHz)	185.780mW (22.69dBm)	187.068mW (22.72dBm)	143.880mW (21.58dBm)	91.411mW (19.61dBm)	64.863mW (18.12dBm)
	n71 (Channel Bandwidth 15MHz)	185.780mW (22.69dBm)	187.068mW (22.72dBm)	142.561mW (21.54dBm)	92.683mW (19.67dBm)	64.714mW (18.11dBm)
	n71 (Channel Bandwidth 20MHz)	187.068mW (22.72dBm)	189.234mW (22.77dBm)	144.544mW (21.60dBm)	92.897mW (19.68dBm)	65.766mW (18.18dBm)
Emission Designator		$\pi/2$ BPSK	QPSK	16QAM	64QAM	256QAM
	n71 (Channel Bandwidth 5MHz)	4M47G7D	4M46G7D	4M46D7W	4M46D7W	4M46D7W
	n71 (Channel Bandwidth 10MHz)	8M92G7D	8M93G7D	8M92D7W	8M93D7W	8M94D7W
	n71 (Channel Bandwidth 15MHz)	13M4G7D	13M4G7D	13M4D7W	13M4D7W	13M4D7W
	n71 (Channel Bandwidth 20MHz)	17M8G7D	17M9G7D	17M9D7W	17M9D7W	17M9D7W

### LTE Band

Modulation Type	QPSK, 16QAM, 64QAM, 256QAM				
Operating Frequency	LTE Band 2 (Channel Bandwidth 1.4MHz)	1850.7MHz ~ 1909.3MHz			
	LTE Band 2 (Channel Bandwidth 3MHz)	1851.5MHz ~ 1908.5MHz			
	LTE Band 2 (Channel Bandwidth 5MHz)	1852.5MHz ~ 1907.5MHz			
	LTE Band 2 (Channel Bandwidth 10MHz)	1855.0MHz ~ 1905.0MHz			
	LTE Band 2 (Channel Bandwidth 15MHz)	1857.5MHz ~ 1902.5MHz			
	LTE Band 2 (Channel Bandwidth 20MHz)	1860.0MHz ~ 1900.0MHz			
	LTE Band 66 (Channel Bandwidth 1.4MHz)	1710.7MHz ~ 1779.3MHz			
	LTE Band 66 (Channel Bandwidth 3MHz)	1711.5MHz ~ 1778.5MHz			
	LTE Band 66 (Channel Bandwidth 5MHz)	1712.5MHz ~ 1777.5MHz			
	LTE Band 66 (Channel Bandwidth 10MHz)	1715.0MHz ~ 1775.0MHz			
	LTE Band 66 (Channel Bandwidth 15MHz)	1717.5MHz ~ 1772.5MHz			
	LTE Band 66 (Channel Bandwidth 20MHz)	1720.0MHz ~ 1770.0MHz			
Max. EIRP Power		QPSK	16QAM	64QAM	256QAM
	LTE Band 2 (Channel Bandwidth 1.4MHz)	309.742mW (24.91dBm)	241.546mW (23.83dBm)	192.752mW (22.85dBm)	98.628mW (19.94dBm)
	LTE Band 2 (Channel Bandwidth 3MHz)	299.226mW (24.76dBm)	244.343mW (23.88dBm)	187.499mW (22.73dBm)	96.605mW (19.85dBm)
	LTE Band 2 (Channel Bandwidth 5MHz)	298.538mW (24.75dBm)	243.220mW (23.86dBm)	187.499mW (22.73dBm)	95.060mW (19.78dBm)
	LTE Band 2 (Channel Bandwidth 10MHz)	297.167mW (24.73dBm)	239.332mW (23.79dBm)	186.638mW (22.71dBm)	97.051mW (19.87dBm)
	LTE Band 2 (Channel Bandwidth 15MHz)	298.538mW (24.75dBm)	241.546mW (23.83dBm)	188.799mW (22.76dBm)	96.383mW (19.84dBm)
	LTE Band 2 (Channel Bandwidth 20MHz)	300.608mW (24.78dBm)	246.037mW (23.91dBm)	188.799mW (22.76dBm)	97.949mW (19.91dBm)
	LTE Band 66 (Channel Bandwidth 1.4MHz)	574.116mW (27.59dBm)	615.177mW (27.89dBm)	490.908mW (26.91dBm)	216.770mW (23.36dBm)
	LTE Band 66 (Channel Bandwidth 3MHz)	440.555mW (26.44dBm)	431.519mW (26.35dBm)	339.625mW (25.31dBm)	169.434mW (22.29dBm)
	LTE Band 66 (Channel Bandwidth 5MHz)	481.948mW (26.83dBm)	490.908mW (26.91dBm)	388.150mW (25.89dBm)	169.044mW (22.28dBm)
	LTE Band 66 (Channel Bandwidth 10MHz)	468.813mW (26.71dBm)	492.040mW (26.92dBm)	385.478mW (25.86dBm)	168.655mW (22.27dBm)
	LTE Band 66 (Channel Bandwidth 15MHz)	488.652mW (26.89dBm)	509.331mW (27.07dBm)	380.189mW (25.80dBm)	170.216mW (22.31dBm)
LTE Band 66 (Channel Bandwidth 20MHz)	480.839mW (26.82dBm)	505.825mW (27.04dBm)	383.707mW (25.84dBm)	172.982mW (22.38dBm)	
Antenna Type	Refer to Note as below				
Antenna Connector	Refer to Note as below				
Accessory Device	Refer to Note as below				
Cable Supplied	Refer to Note as below				

Note:

1. The EUT contains following accessory devices.

Product	Brand	Model	Description
Adapter 1	TEN PAO INTERNATIONAL LTD.	S018BYU1200150	I/P: 100-240Vac, 50/60Hz, 600mA O/P: 5Vdc/9Vdc/12Vdc=3A/2A/1.5A
Adapter 2	Aohai Technology Co., Ltd	A138A-120150U-US2	I/P: 100-240V~50/60Hz, 0.5A O/P: 5Vdc, 2.5A/9Vdc, 2A/12Vdc, 1.5A
USB Cable 1	Electronics Taiwai Ltd.	DDEMU110079	0.95m shielded USB cable without core
USB Cable 2	IMEX INC	60-6382-520-FA	0.97m shielded USB cable without core
Battery	VEKEN	141033	3.85Vdc, 6460mAh, 24.87Wh

\* After pre-tested, adapter 2 and USB cable 1 were the worst case and chosen for final test.

2. There are two sources for EUT's memory. Only the supplier is different and the rest of the specifications are the same.

Sample	Item	Brand	Model
A	Memory - Main	Nanya Technology Corporation	NM4888KSPAXAI-3E
B	Memory - Second	Jeju Semiconductor Corp.	JSFDDQ5QHAFGD-405

\* After pre-tested, sample A was the worse and chosen for final test.

3. The following antennas were provided to the EUT.

LTE Band														
Ant. No.	Type	Connector	Gain (dBi)											
			B2	B4	B5	B7	B12	B13	B25	B26	B38	B41	B66	B71
0	PIFA	MUR	1.23871	3.16163	0.345671	1.15435	0.154297	-3.23099	1.23871	0.702007	0.371642	1.15435	3.16163	0.426023
1	PIFA	IPEX	-	-	-	-	-	-	-	-	-	-	-	-
2	PIFA	IPEX	0.861738	0.805343	-	-	-	-	-	-	-	-	0.805343	-
3	PIFA	MUR	-	-	-	-	-	-	-	-	-	-	-	-
4	PIFA	IPEX	-	-	-	-	-	-	-	-	-	-	-	-

5G FR1 Band							
Ant. No.	Type	Connector	Gain (dBi)				
			n25	n41	n66	n71	
0	PIFA	MUR	1.23871	-	3.16163	0.426023	
1	PIFA	IPEX	-	-	-	-	
2	PIFA	IPEX	-	0.854078	-	-	
3	PIFA	MUR	-	-	-	-	
4	PIFA	IPEX	-	-0.283214	-	-	

\* The above Antenna information is declared by manufacturer and for more detailed features description, please refer to the manufacturer's specifications, the laboratory shall not be held responsible.

4. The EUT supports the following ENDC configuration.

5G NR	FCC 5G FR1			ENDC
	Band	SCS	Bandwidth (MHz)	
	n25	15kHz	5/10/15/20	Band 66
	n41	30kHz	10/15/20/40/50/60/80/90/100	Band 2/66
	n66	15kHz	5/10/15/20/40	Band 2
	n71	15kHz	5/10/15/20	Band 2/66

### 3.2 Configuration of System under Test

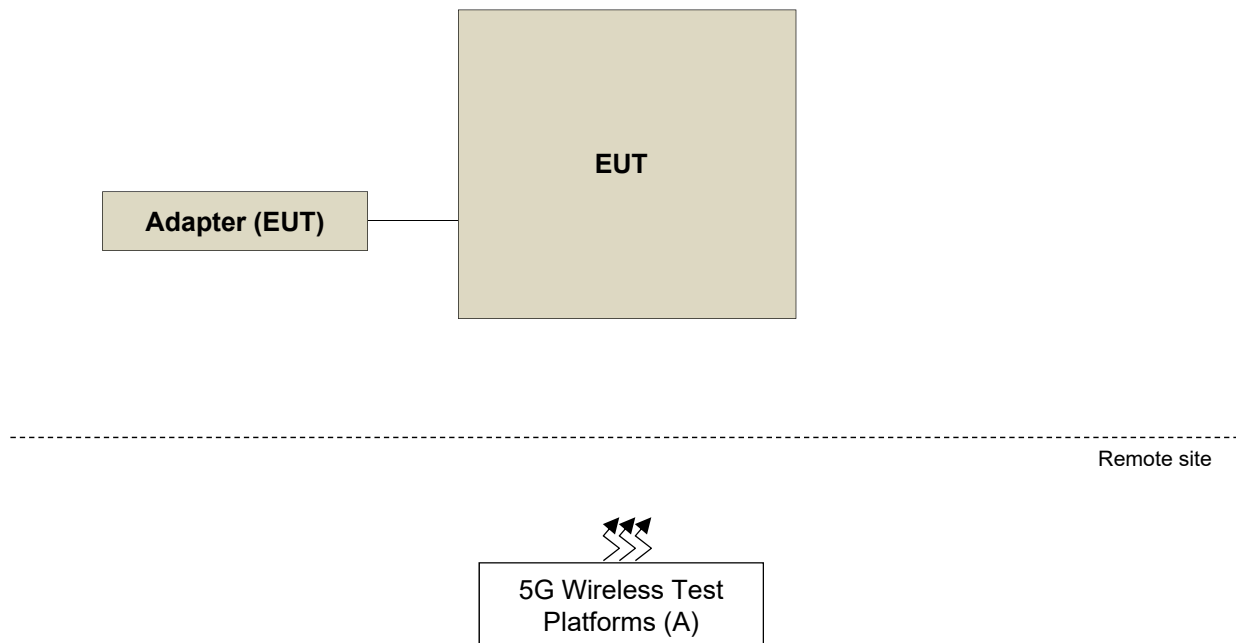

#### 3.2.1 Description of Support Units

The EUT has been tested as an independent unit together with other necessary accessories or support units. The following support units or accessories were used to form a representative test configuration during the tests.

ID	Product	Brand	Model No.	Serial No.	FCC ID	Remarks
A.	5G Wireless Test Platforms	Keysight	E7515B	MY58300759	NA	-

Note:

1. All power cords of the above support units are non-shielded (1.8m).
2. Item A acted as a communication partner to transfer data.

### 3.3 Test Mode Applicability and Tested Channel Detail

Pre-Scan has been conducted to determine the worst-case mode from all possible combinations between available modulations, data rates, XYZ axis and antenna ports. The worst case was found when positioned as the table below. Following channel(s) was (were) selected for the final test as listed below:

Band	Radiated Emission
n71	X-plane
LTE Band 2	X-plane
LTE Band 66	X-plane

n71

EUT Configure Mode	Test item	Available channel	Tested channel	Channel Bandwidth	Modulation	Mode
-	ERP	133100 to 139100	133100 (665.5MHz), 136100 (680.5MHz), 139100 (695.5MHz)	5MHz	$\pi/2$ BPSK / QPSK / 16QAM / 64QAM / 256QAM	1 RB / 1 RB Offset 1 RB / 13 RB Offset 1 RB / 23 RB Offset 12 RB / 0 RB Offset 12 RB / 7 RB Offset 12 RB / 13 RB Offset 25 RB / 0 RB Offset
		133600 to 138600	133600 (668.0MHz), 136100 (680.5MHz), 138600 (693.0MHz)	10MHz	$\pi/2$ BPSK / QPSK / 16QAM / 64QAM / 256QAM	1 RB / 1 RB Offset 1 RB / 26 RB Offset 1 RB / 50 RB Offset 25 RB / 0 RB Offset 25 RB / 14 RB Offset 25 RB / 27 RB Offset 50 RB / 0 RB Offset
		134100 to 138100	134100 (670.5MHz), 136100 (680.5MHz), 138100 (690.5MHz)	15MHz	$\pi/2$ BPSK / QPSK / 16QAM / 64QAM / 256QAM	1 RB / 1 RB Offset 1 RB / 40 RB Offset 1 RB / 77 RB Offset 36 RB / 0 RB Offset 36 RB / 22 RB Offset 36 RB / 43 RB Offset 75 RB / 0 RB Offset
		134600 to 137600	134600 (673.0MHz), 136100 (680.5MHz), 137600 (688.0MHz)	20MHz	$\pi/2$ BPSK / QPSK / 16QAM / 64QAM / 256QAM	1 RB / 1 RB Offset 1 RB / 53 RB Offset 1 RB / 104 RB Offset 50RB / 0 RB Offset 50 RB / 28 RB Offset 50 RB / 56 RB Offset 100 RB / 0 RB Offset
-	Modulation Characteristics	134600 to 137600	136100 (680.5MHz)	20MHz	$\pi/2$ BPSK / QPSK / 16QAM / 64QAM / 256QAM	106 RB / 0 RB Offset
-	Frequency Stability	133100 to 139100	133100 (665.5MHz), 139100 (695.5MHz)	5MHz	$\pi/2$ BPSK	25 RB / 0 RB Offset
		133600 to 138600	133600 (668.0MHz), 138600 (693.0MHz)	10MHz	$\pi/2$ BPSK	52 RB / 0 RB Offset
		134100 to 138100	134100 (670.5MHz), 138100 (690.5MHz)	15MHz	$\pi/2$ BPSK	79 RB / 0 RB Offset
		134600 to 137600	134600 (673.0MHz), 137600 (688.0MHz)	20MHz	$\pi/2$ BPSK	106 RB / 0 RB Offset

EUT Configure Mode	Test item	Available channel	Tested channel	Channel Bandwidth	Modulation	Mode
-	Emission Bandwidth	133100 to 139100	133100 (665.5MHz), 136100 (680.5MHz), 139100 (695.5MHz)	5MHz	$\pi/2$ BPSK / QPSK / 16QAM / 64QAM / 256QAM	25 RB / 0 RB Offset
		133600 to 138600	133600 (668.0MHz), 136100 (680.5MHz), 138600 (693.0MHz)	10MHz	$\pi/2$ BPSK / QPSK / 16QAM / 64QAM / 256QAM	52 RB / 0 RB Offset
		134100 to 138100	134100 (670.5MHz), 136100 (680.5MHz), 138100 (690.5MHz)	15MHz	$\pi/2$ BPSK / QPSK / 16QAM / 64QAM / 256QAM	79 RB / 0 RB Offset
		134600 to 137600	134600 (673.0MHz), 136100 (680.5MHz), 137600 (688.0MHz)	20MHz	$\pi/2$ BPSK / QPSK / 16QAM / 64QAM / 256QAM	106 RB / 0 RB Offset
-	Band Edge	133100 to 139100	133100 (665.5MHz), 139100 (695.5MHz)	5MHz	$\pi/2$ BPSK	1 RB / 0 RB Offset 1 RB / 24 RB Offset 25 RB / 0 RB Offset
		133600 to 138600	133600 (668.0MHz), 138600 (693.0MHz)	10MHz	$\pi/2$ BPSK	1 RB / 0 RB Offset 1 RB / 51 RB Offset 52 RB / 0 RB Offset
		134100 to 138100	134100 (670.5MHz), 138100 (690.5MHz)	15MHz	$\pi/2$ BPSK	1 RB / 0 RB Offset 1 RB / 78 RB Offset 79 RB / 0 RB Offset
		134600 to 137600	134600 (673.0MHz), 137600 (688.0MHz)	20MHz	$\pi/2$ BPSK	1 RB / 0 RB Offset 1 RB / 105 RB Offset 106 RB / 0 RB Offset
-	Peak to Average Ratio	133100 to 139100	133100 (665.5MHz), 136100 (680.5MHz), 139100 (695.5MHz)	5MHz	$\pi/2$ BPSK / QPSK / 16QAM / 64QAM / 256QAM	1 RB / 1 RB Offset
		133600 to 138600	133600 (668.0MHz), 136100 (680.5MHz), 138600 (693.0MHz)	10MHz	$\pi/2$ BPSK / QPSK / 16QAM / 64QAM / 256QAM	1 RB / 1 RB Offset
		134100 to 138100	134100 (670.5MHz), 136100 (680.5MHz), 138100 (690.5MHz)	15MHz	$\pi/2$ BPSK / QPSK / 16QAM / 64QAM / 256QAM	1 RB / 1 RB Offset
		134600 to 137600	134600 (673.0MHz), 136100 (680.5MHz), 137600 (688.0MHz)	20MHz	$\pi/2$ BPSK / QPSK / 16QAM / 64QAM / 256QAM	1 RB / 1 RB Offset

EUT Configure Mode	Test item	Available channel	Tested channel	Channel Bandwidth	Modulation	Mode
-	Conducted Emission	133100 to 139100	133100 (665.5MHz), 136100 (680.5MHz), 139100 (695.5MHz)	5MHz	$\pi/2$ BPSK	1 RB / 1 RB Offset
		133600 to 138600	133600 (668.0MHz), 136100 (680.5MHz), 138600 (693.0MHz)	10MHz	QPSK	1 RB / 1 RB Offset
		134100 to 138100	134100 (670.5MHz), 136100 (680.5MHz), 138100 (690.5MHz)	15MHz	QPSK	1 RB / 1 RB Offset
		134600 to 137600	134600 (673.0MHz), 136100 (680.5MHz), 137600 (688.0MHz)	20MHz	QPSK	1 RB / 1 RB Offset
-	Radiated Emission Below 1GHz	134600 to 137600	136100 (680.5MHz)	20MHz	QPSK	1 RB / 1 RB Offset
-	Radiated Emission Above 1GHz	133100 to 139100	133100 (665.5MHz), 136100 (680.5MHz), 139100 (695.5MHz)	5MHz	$\pi/2$ BPSK	1 RB / 1 RB Offset
		134600 to 137600	134600 (673.0MHz), 136100 (680.5MHz), 137600 (688.0MHz)	20MHz	QPSK	1 RB / 1 RB Offset

Note:

1. For radiated emission below 1GHz, select the worst radiated emission channel (above 1GHz) for final testing.
2. For radiated emission above 1GHz, according to 3GPP 38.521-1 Section 6.5.3.1.4, choose the lowest and highest channel bandwidth for final test.
3. Only output power, modulation characteristics, occupied bandwidth and Peak to average ratio items had been tested under  $\pi/2$  BPSK, QPSK, 16QAM, 64QAM and 256QAM modes, the other test items were performed under worse mode according to the maximum output power.



## LTE Band 2

EUT Configure Mode	Test item	Available channel	Tested Channel	Channel Bandwidth	Modulation	Mode
-	EIRP	18607 to 19193	18607 (1850.7MHz), 18900 (1880.0MHz), 19193 (1909.3MHz)	1.4MHz	QPSK / 16QAM / 64QAM / 256QAM	1 RB / 0 RB Offset 1 RB / 2 RB Offset 1 RB / 5 RB Offset 3 RB / 0 RB Offset 3 RB / 1 RB Offset 3 RB / 3 RB Offset 6 RB / 0 RB Offset
		18615 to 19185	18615 (1851.5MHz), 18900 (1880.0MHz), 19185 (1908.5MHz)	3MHz	QPSK / 16QAM / 64QAM / 256QAM	1 RB / 0 RB Offset 1 RB / 7 RB Offset 1 RB / 14 RB Offset 8 RB / 0 RB Offset 8 RB / 3 RB Offset 8 RB / 7 RB Offset 15 RB / 0 RB Offset
		18625 to 19175	18625 (1852.5MHz), 18900 (1880.0MHz), 19175 (1907.5MHz)	5MHz	QPSK / 16QAM / 64QAM / 256QAM	1 RB / 0 RB Offset 1 RB / 12 RB Offset 1 RB / 24 RB Offset 12 RB / 0 RB Offset 12 RB / 6 RB Offset 12 RB / 13 RB Offset 25 RB / 0 RB Offset
		18650 to 19150	18650 (1855.0MHz), 18900 (1880.0MHz), 19150 (1905.0MHz)	10MHz	QPSK / 16QAM / 64QAM / 256QAM	1 RB / 0 RB Offset 1 RB / 24 RB Offset 1 RB / 49 RB Offset 25 RB / 0 RB Offset 25 RB / 12 RB Offset 25 RB / 25 RB Offset 50 RB / 0 RB Offset
		18675 to 19125	18675 (1857.5MHz), 18900 (1880.0MHz), 19125 (1902.5MHz)	15MHz	QPSK / 16QAM / 64QAM / 256QAM	1 RB / 0 RB Offset 1 RB / 37 RB Offset 1 RB / 74 RB Offset 36 RB / 0 RB Offset 36 RB / 19 RB Offset 36 RB / 39 RB Offset 75 RB / 0 RB Offset
		18700 to 19100	18700 (1860.0MHz), 18900 (1880.0MHz), 19100 (1900.0MHz)	20MHz	QPSK / 16QAM / 64QAM / 256QAM	1 RB / 0 RB Offset 1 RB / 50 RB Offset 1 RB / 99 RB Offset 50 RB / 0 RB Offset 50 RB / 25 RB Offset 50 RB / 50 RB Offset 100 RB / 0 RB Offset

EUT Configure Mode	Test item	Available channel	Tested Channel	Channel Bandwidth	Modulation	Mode
-	Radiated Emission Below 1GHz	18700 to 19100	19100 (1900.0MHz)	20MHz	QPSK	1 RB / 0 RB Offset
-	Radiated Emission Above 1GHz	18607 to 19193	18607 (1850.7MHz), 18900 (1880.0MHz), 19193 (1909.3MHz)	1.4MHz	QPSK	1 RB / 0 RB Offset
		18625 to 19175	18625 (1852.5MHz), 18900 (1880.0MHz), 19175 (1907.5MHz)	5MHz	QPSK	1 RB / 0 RB Offset
		18700 to 19100	18700 (1860.0MHz), 18900 (1880.0MHz), 19100 (1900.0MHz)	20MHz	QPSK	1 RB / 0 RB Offset

Note:

1. For radiated emission below 1GHz, select the worst radiated emission channel (above 1GHz) for final testing.
2. For radiated emission above 1GHz, according to 3GPP 36.521 Section 6.6.3.1.4, choose the lowest, 5MHz & highest channel bandwidth for final test.
3. The output power for QPSK, 16QAM, 64QAM and 256QAM, measured value of QPSK is higher than 16QAM, 64QAM and 256QAM mode. Therefore the radiated emission test items was performed under QPSK mode only.

## LTE Band 66

EUT Configure Mode	Test Item	Available Channel	Tested Channel	Channel Bandwidth	Modulation	Mode
-	EIRP	131979 to 132665	131979 (1710.7MHz), 132322 (1745.0MHz), 132665 (1779.3MHz)	1.4MHz	QPSK / 16QAM / 64QAM / 256QAM	1 RB / 0 RB Offset 1 RB / 2 RB Offset 1 RB / 5 RB Offset 3 RB / 0 RB Offset 3 RB / 1 RB Offset 3 RB / 3 RB Offset 6 RB / 0 RB Offset
		131987 to 132657	131987 (1711.5MHz), 132322 (1745.0MHz), 132657 (1778.5MHz)	3MHz	QPSK / 16QAM / 64QAM / 256QAM	1 RB / 0 RB Offset 1 RB / 7 RB Offset 1 RB / 14 RB Offset 8 RB / 0 RB Offset 8 RB / 3 RB Offset 8 RB / 7 RB Offset 15 RB / 0 RB Offset
		131997 to 132647	131997 (1712.5MHz), 132322 (1745.0MHz), 132647 (1777.5MHz)	5MHz	QPSK / 16QAM / 64QAM / 256QAM	1 RB / 0 RB Offset 1 RB / 12 RB Offset 1 RB / 24 RB Offset 12 RB / 0 RB Offset 12 RB / 6 RB Offset 12 RB / 13 RB Offset 25 RB / 0 RB Offset
		132022 to 132622	132022 (1715.0MHz), 132322 (1745.0MHz), 132622 (1775.0MHz)	10MHz	QPSK / 16QAM / 64QAM / 256QAM	1 RB / 0 RB Offset 1 RB / 24 RB Offset 1 RB / 49 RB Offset 25 RB / 0 RB Offset 25 RB / 12 RB Offset 25 RB / 25 RB Offset 50 RB / 0 RB Offset
		132047 to 132597	132047 (1717.5MHz), 132322 (1745.0MHz), 132597 (1772.5MHz)	15MHz	QPSK / 16QAM / 64QAM / 256QAM	1 RB / 0 RB Offset 1 RB / 37 RB Offset 1 RB / 74 RB Offset 36 RB / 0 RB Offset 36 RB / 19 RB Offset 36 RB / 39 RB Offset 75 RB / 0 RB Offset
		132072 to 132572	132072 (1720.0MHz), 132322 (1745.0MHz), 132572 (1770.0MHz)	20MHz	QPSK / 16QAM / 64QAM / 256QAM	1 RB / 0 RB Offset 1 RB / 50 RB Offset 1 RB / 99 RB Offset 50 RB / 0 RB Offset 50 RB / 25 RB Offset 50 RB / 50 RB Offset 100 RB / 0 RB Offset

EUT Configure Mode	Test Item	Available Channel	Tested Channel	Channel Bandwidth	Modulation	Mode
-	Radiated Emission Below 1GHz	132072 to 132572	132572 (1770.0MHz)	20MHz	16QAM	1 RB / 0 RB Offset
-	Radiated Emission Above 1GHz	131979 to 132665	131979 (1710.7MHz), 132322 (1745.0MHz), 132665 (1779.3MHz)	1.4MHz	16QAM	1 RB / 0 RB Offset
		131997 to 132647	131997 (1712.5MHz), 132322 (1745.0MHz), 132647 (1777.5MHz)	5MHz	16QAM	1 RB / 0 RB Offset
		132072 to 132572	132072 (1720.0MHz), 132322 (1745.0MHz), 132572 (1770.0MHz)	20MHz	16QAM	1 RB / 0 RB Offset

**Note:**

1. For radiated emission below 1GHz, select the worst radiated emission channel (above 1GHz) for final testing.
2. For radiated emission above 1GHz, according to 3GPP 36.521 Section 6.6.3.1.4, choose the lowest, 5MHz & highest channel bandwidth for final test.
3. The output power for QPSK, 16QAM, 64QAM and 256QAM, measured value of 16QAM is higher than QPSK, 64QAM and 256QAM mode. Therefore the radiated emission test items was performed under 16QAM mode only.

**Test Condition:**

Test Item	Environmental Conditions	Input Power	Tested By
ERP / EIRP	25deg. C, 60%RH	120Vac, 60Hz	James Yang
Modulation Characteristics	25deg. C, 60%RH	120Vac, 60Hz	James Yang
Frequency Stability	25deg. C, 60%RH	3.85Vdc	James Yang
Occupied Bandwidth	25deg. C, 60%RH	120Vac, 60Hz	James Yang
Band Edge	25deg. C, 60%RH	120Vac, 60Hz	James Yang
Peak To Average Ratio	25deg. C, 60%RH	120Vac, 60Hz	James Yang
Conducted Emission	25deg. C, 60%RH	120Vac, 60Hz	James Yang
Radiated Emission	23deg. C, 65%RH 22deg. C, 66%RH	120Vac, 60Hz	Jones Chang Rex Wang

### **3.4 EUT Operating Conditions**

The EUT makes a call to the communication simulator. The communication simulator station system controlled a EUT to export maximum output power under transmission mode and specific channel frequency

### **3.5 General Description of Applied Standards and References**

The EUT is a RF Product. According to the specifications of the manufacturer, it must comply with the requirements of the following standards and References:

#### **Test Standard:**

**FCC 47 CFR Part 2**

**FCC 47 CFR Part 24**

**FCC 47 CFR Part 27**

**ANSI/TIA/EIA-603-D-2010**

**ANSI/TIA/EIA-603-E 2016**

ANSI 63.26-2015

All test items have been performed and recorded as per the above standards.

#### **References Test Guidance:**

**KDB 971168 D01 Power Meas License Digital Systems v03r01**

**KDB 971168 D02 Misc Rev Approv License Devices v02r01**

All test items have been performed and recorded as per the above standards.

## 4 Test Types and Results

### 4.1 Output Power Measurement

#### 4.1.1 Limits of Output Power Measurement

For n71:

Portable stations (hand-held devices) in the 600 MHz uplink band and the 698-746 MHz band, and fixed and mobile stations in the 600 MHz uplink band are limited to 3 watts ERP.

For LTE Band 2:

Mobile / Portable station are limited to 2 watts e.i.r.p.

For LTE Band 66:

Mobile / Portable station are limited to 1 watts e.i.r.p.

#### 4.1.2 Test Procedures

##### Conducted Power Measurement:

The EUT was set up for the maximum power with 5GNR and LTE link data modulation and link up with simulator. Set the EUT to transmit under low, middle and high channel and record the power level shown on simulator.

##### Maximum EIRP / ERP

The relevant equation for determining the maximum ERP or EIRP from the measured RF output power is

given in Equation as follows:

$$\text{EIRP} = P_{\text{Meas}} + G_{\text{T}}$$

$$\text{ERP} = P_{\text{Meas}} + G_{\text{T}} - 2.15$$

where

ERP or EIRP effective radiated power or equivalent isotropically radiated power, respectively  
(expressed in the same units as  $P_{\text{Meas}}$ , e.g., dBm or dBW)

$P_{\text{Meas}}$  measured transmitter output power or PSD, in dBm or dBW

$G_{\text{T}}$  gain of the transmitting antenna, in dBd (ERP) or dBi (EIRP)

#### 4.1.3 Test Setup

Conducted Power Measurement:

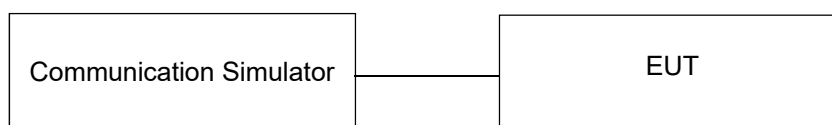

#### 4.1.4 Test Results

##### Conducted Output Power (dBm)

NR Band 71						
BW	MCS Index	RB Size	RB Offset	Low	Mid	High
		Channel		134600	136100	137600
		Frequency (MHz)		673	680.5	688
20M	$\pi/2$ BPSK	1	1	24.44	24.38	24.24
20M	QPSK	1	1	24.49	24.39	24.39
		1	53	24.48	24.44	24.38
		1	104	24.46	24.42	24.36
		50	0	23.40	23.39	23.33
		50	28	23.43	23.36	23.30
		50	56	23.40	23.36	23.30
		100	0	23.45	23.41	23.35
20M	16QAM	1	1	23.32	23.28	23.22
20M	64QAM	1	1	21.40	21.36	21.30
20M	256QAM	1	1	19.90	19.86	19.80
BW	MCS Index	Channel		134100	136100	138100
		Frequency (MHz)		670.5	680.5	690.5
15M	$\pi/2$ BPSK	1	1	24.41	24.36	24.29
15M	QPSK	1	1	24.34	24.43	24.37
		1	40	24.44	24.32	24.29
		1	77	24.38	24.24	24.19
		36	0	23.36	23.37	23.22
		36	22	23.21	23.18	23.22
		36	43	23.32	23.30	23.12
		75	0	23.39	23.35	23.28
15M	16QAM	1	1	23.26	23.24	23.20
15M	64QAM	1	1	21.39	21.28	21.20
15M	256QAM	1	1	19.83	19.77	19.71
BW	MCS Index	Channel		133600	136100	138600
		Frequency (MHz)		668	680.5	693
10M	$\pi/2$ BPSK	1	1	24.41	24.34	24.24
10M	QPSK	1	1	24.37	24.32	24.24
		1	26	24.44	24.37	24.25
		1	50	24.29	24.30	24.29
		25	0	23.27	23.36	23.19
		25	14	23.26	23.30	23.22
		25	27	23.31	23.18	23.26
		50	0	23.39	23.31	23.24
10M	16QAM	1	1	23.30	23.22	23.16
10M	64QAM	1	1	21.33	21.31	21.28
10M	256QAM	1	1	19.81	19.84	19.80

NR Band 71						
BW	MCS Index	RB Size	RB Offset	Low	Mid	High
		Channel		133100	136100	139100
		Frequency (MHz)		665.5	680.5	695.5
5M	$\pi/2$ BPSK	1	1	24.40	24.43	24.34
5M	QPSK	1	1	24.31	24.35	24.29
		1	13	24.40	24.32	24.23
		1	23	24.28	24.35	24.25
		12	0	23.29	23.35	23.20
		12	7	23.29	23.29	23.19
		12	13	23.29	23.31	23.13
		25	0	23.41	23.28	23.19
5M	16QAM	1	1	23.28	23.24	23.22
5M	64QAM	1	1	21.30	21.26	21.27
5M	256QAM	1	1	19.90	19.80	19.72



LTE Band 2						
BW	MCS Index	RB Size	RB Offset	Low	Mid	High
		Channel		18700	18900	19100
		Frequency (MHz)		1860	1880	1900
20M	QPSK	1	0	23.54	23.50	23.47
		1	50	23.48	23.47	23.39
		1	99	23.46	23.42	23.31
		50	0	22.66	22.66	22.55
		50	25	22.62	22.53	22.52
		50	50	22.52	22.50	22.53
		100	0	22.56	22.48	22.43
20M	16QAM	1	0	22.67	22.57	22.58
		1	50	22.60	22.62	22.52
		1	99	22.56	22.59	22.55
		50	0	21.56	21.58	21.56
		50	25	21.50	21.48	21.48
		50	50	21.55	21.50	21.49
		100	0	21.48	21.46	21.42
20M	64QAM	1	0	21.48	21.44	21.48
		1	50	21.49	21.49	21.36
		1	99	21.52	21.41	21.41
		50	0	20.72	20.63	20.64
		50	25	20.67	20.54	20.49
		50	50	20.62	20.56	20.52
		100	0	20.60	20.56	20.48
20M	256QAM	1	0	18.59	18.58	18.51
		1	50	18.67	18.61	18.58
		1	99	18.54	18.48	18.48
		50	0	18.57	18.58	18.50
		50	25	18.59	18.57	18.51
		50	50	18.58	18.51	18.45
		100	0	18.61	18.53	18.45

LTE Band 2						
BW	MCS Index	RB Size	RB Offset	Low	Mid	High
		Channel		18675	18900	19125
		Frequency (MHz)		1857.5	1880	1902.5
15M	QPSK	1	0	23.51	23.43	23.37
		1	37	23.39	23.48	23.27
		1	74	23.35	23.37	23.25
		36	0	22.63	22.54	22.50
		36	19	22.51	22.47	22.54
		36	39	22.53	22.50	22.40
		75	0	22.57	22.53	22.49
15M	16QAM	1	0	22.50	22.51	22.46
		1	37	22.51	22.59	22.43
		1	74	22.48	22.45	22.44
		36	0	21.53	21.49	21.38
		36	19	21.44	21.47	21.34
		36	39	21.41	21.38	21.43
		75	0	21.39	21.42	21.29
15M	64QAM	1	0	21.52	21.39	21.43
		1	37	21.34	21.44	21.28
		1	74	21.37	21.34	21.35
		36	0	20.69	20.52	20.50
		36	19	20.56	20.59	20.56
		36	39	20.65	20.42	20.52
		75	0	20.57	20.45	20.47
15M	256QAM	1	0	18.54	18.44	18.49
		1	37	18.60	18.48	18.46
		1	74	18.50	18.48	18.37
		36	0	18.57	18.41	18.45
		36	19	18.53	18.42	18.34
		36	39	18.39	18.51	18.49
		75	0	18.56	18.44	18.43

LTE Band 2						
BW	MCS Index	RB Size	RB Offset	Low	Mid	High
		Channel		18650	18900	19150
		Frequency (MHz)		1855	1880	1905
10M	QPSK	1	0	23.49	23.33	23.41
		1	24	23.40	23.35	23.17
		1	49	23.40	23.22	23.16
		25	0	22.64	22.52	22.40
		25	12	22.57	22.53	22.35
		25	25	22.56	22.45	22.28
		50	0	22.55	22.34	22.33
10M	16QAM	1	0	22.55	22.46	22.51
		1	24	22.41	22.41	22.39
		1	49	22.53	22.40	22.38
		25	0	21.51	21.53	21.47
		25	12	21.44	21.38	21.39
		25	25	21.56	21.31	21.40
		50	0	21.39	21.48	21.35
10M	64QAM	1	0	21.40	21.47	21.30
		1	24	21.35	21.42	21.35
		1	49	21.30	21.39	21.33
		25	0	20.70	20.50	20.59
		25	12	20.45	20.47	20.36
		25	25	20.50	20.43	20.43
		50	0	20.46	20.43	20.31
10M	256QAM	1	0	18.59	18.57	18.50
		1	24	18.53	18.52	18.41
		1	49	18.55	18.33	18.34
		25	0	18.55	18.43	18.39
		25	12	18.63	18.58	18.39
		25	25	18.47	18.49	18.43
		50	0	18.60	18.45	18.50

LTE Band 2						
BW	MCS Index	RB Size	RB Offset	Low	Mid	High
		Channel		18625	18900	19175
		Frequency (MHz)		1852.5	1880	1907.5
5M	QPSK	1	0	23.51	23.47	23.28
		1	12	23.47	23.38	23.17
		1	24	23.46	23.28	23.25
		12	0	22.55	22.52	22.44
		12	6	22.56	22.61	22.42
		12	13	22.42	22.58	22.29
		25	0	22.57	22.48	22.29
5M	16QAM	1	0	22.50	22.46	22.44
		1	12	22.62	22.46	22.46
		1	24	22.48	22.43	22.46
		12	0	21.52	21.41	21.41
		12	6	21.45	21.40	21.47
		12	13	21.52	21.42	21.42
		25	0	21.46	21.37	21.38
5M	64QAM	1	0	21.41	21.38	21.33
		1	12	21.31	21.38	21.35
		1	24	21.46	21.49	21.30
		12	0	20.56	20.62	20.61
		12	6	20.55	20.55	20.47
		12	13	20.64	20.54	20.41
		25	0	20.49	20.40	20.50
5M	256QAM	1	0	18.54	18.43	18.51
		1	12	18.47	18.50	18.52
		1	24	18.53	18.32	18.27
		12	0	18.44	18.38	18.45
		12	6	18.52	18.46	18.33
		12	13	18.34	18.44	18.34
		25	0	18.49	18.46	18.38

LTE Band 2						
BW	MCS Index	RB Size	RB Offset	Low	Mid	High
		Channel		18615	18900	19185
		Frequency (MHz)		1851.5	1880	1908.5
3M	QPSK	1	0	23.52	23.51	23.42
		1	7	23.48	23.41	23.29
		1	14	23.33	23.26	23.20
		8	0	22.53	22.54	22.47
		8	3	22.47	22.60	22.48
		8	7	22.50	22.37	22.39
		15	0	22.47	22.55	22.36
3M	16QAM	1	0	22.64	22.55	22.38
		1	7	22.54	22.50	22.50
		1	14	22.44	22.54	22.44
		8	0	21.52	21.52	21.52
		8	3	21.40	21.40	21.40
		8	7	21.44	21.38	21.29
		15	0	21.50	21.31	21.41
3M	64QAM	1	0	21.49	21.41	21.41
		1	7	21.49	21.35	21.37
		1	14	21.41	21.31	21.41
		8	0	20.56	20.58	20.50
		8	3	20.63	20.48	20.38
		8	7	20.47	20.46	20.39
		15	0	20.52	20.38	20.39
3M	256QAM	1	0	18.58	18.52	18.43
		1	7	18.49	18.59	18.38
		1	14	18.46	18.39	18.39
		8	0	18.49	18.44	18.39
		8	3	18.61	18.44	18.37
		8	7	18.48	18.41	18.34
		15	0	18.53	18.43	18.35

LTE Band 2						
BW	MCS Index	RB Size	RB Offset	Low	Mid	High
		Channel		18607	18900	19193
		Frequency (MHz)		1850.7	1880	1909.3
1.4M	QPSK	1	0	23.47	23.45	23.42
		1	2	23.40	23.31	23.44
		1	5	23.32	23.37	23.22
		3	0	23.67	23.46	23.48
		3	1	23.58	23.42	23.51
		3	3	23.48	23.52	23.32
		6	0	22.55	22.44	22.43
1.4M	16QAM	1	0	22.47	22.49	22.54
		1	2	22.55	22.43	22.47
		1	5	22.53	22.47	22.39
		3	0	22.58	22.59	22.36
		3	1	22.40	22.49	22.38
		3	3	22.39	22.40	22.46
		6	0	21.37	21.39	21.24
1.4M	64QAM	1	0	21.59	21.61	21.45
		1	2	21.48	21.50	21.47
		1	5	21.50	21.45	21.40
		3	0	21.58	21.49	21.37
		3	1	21.39	21.47	21.47
		3	3	21.49	21.33	21.44
		6	0	20.49	20.29	20.23
1.4M	256QAM	1	0	18.47	18.51	18.39
		1	2	18.51	18.40	18.36
		1	5	18.41	18.38	18.41
		3	0	18.70	18.55	18.64
		3	1	18.56	18.46	18.43
		3	3	18.52	18.50	18.56
		6	0	18.50	18.49	18.42

LTE Band 66						
BW	MCS Index	RB Size	RB Offset	Low	Mid	High
		Channel		132072	132322	132572
		Frequency (MHz)		1720	1745	1770
20M	QPSK	1	0	23.30	23.66	23.62
		1	50	22.93	23.51	23.35
		1	99	23.06	23.53	23.42
		50	0	22.83	23.20	22.99
		50	25	22.96	23.52	23.34
		50	50	22.74	23.21	23.06
		100	0	22.82	23.16	23.09
20M	16QAM	1	0	23.54	23.88	23.59
		1	50	22.94	23.58	23.36
		1	99	23.14	23.61	23.56
		50	0	22.25	22.71	22.68
		50	25	23.79	23.81	23.72
		50	50	22.31	22.77	22.69
		100	0	22.24	22.75	22.67
20M	64QAM	1	0	22.23	22.68	22.53
		1	50	20.76	21.29	21.11
		1	99	18.82	19.30	19.18
		50	0	21.90	22.22	22.19
		50	25	21.28	21.77	21.60
		50	50	19.76	20.33	20.10
		100	0	16.81	17.27	17.15
20M	256QAM	1	0	19.20	18.77	19.22
		1	50	18.17	18.21	18.23
		1	99	17.97	17.99	18.10
		50	0	19.10	18.78	19.11
		50	25	18.10	18.14	18.19
		50	50	17.88	17.97	18.05
		100	0	17.93	17.96	17.98

LTE Band 66						
BW	MCS Index	RB Size	RB Offset	Low	Mid	High
		Channel		132047	132322	132597
		Frequency (MHz)		1717.5	1745	1772.5
15M	QPSK	1	0	23.20	23.73	23.49
		1	37	22.99	23.32	23.31
		1	74	23.12	23.42	23.25
		36	0	22.67	23.29	22.89
		36	19	22.84	23.46	23.22
		36	39	22.72	22.98	22.97
		75	0	22.81	22.99	22.94
15M	16QAM	1	0	23.39	23.91	23.47
		1	37	22.96	23.49	23.26
		1	74	23.07	23.61	23.46
		36	0	22.21	22.63	22.66
		36	19	23.58	23.68	23.68
		36	39	22.27	22.69	22.55
		75	0	22.24	22.71	22.49
15M	64QAM	1	0	22.27	22.64	22.45
		1	37	20.70	21.24	21.12
		1	74	18.80	19.18	19.04
		36	0	21.85	22.16	22.04
		36	19	21.29	21.77	21.56
		36	39	19.65	20.22	20.10
		75	0	16.71	17.24	17.08
15M	256QAM	1	0	19.12	18.76	19.15
		1	37	18.11	18.03	18.07
		1	74	17.98	17.97	18.09
		36	0	19.12	18.76	19.07
		36	19	18.04	18.11	18.04
		36	39	17.96	17.94	18.00
		75	0	17.93	17.91	18.00



LTE Band 66						
BW	MCS Index	RB Size	RB Offset	Low	Mid	High
		Channel		132022	132322	132622
		Frequency (MHz)		1715	1745	1775
10M	QPSK	1	0	23.18	23.55	23.52
		1	24	22.88	23.50	23.09
		1	49	22.96	23.41	23.26
		25	0	22.77	23.20	22.83
		25	12	22.76	23.43	23.21
		25	25	22.72	23.01	22.97
		50	0	22.70	23.05	22.85
10M	16QAM	1	0	23.37	23.76	23.50
		1	24	22.91	23.50	23.23
		1	49	23.03	23.61	23.43
		25	0	22.18	22.61	22.63
		25	12	23.70	23.76	23.62
		25	25	22.26	22.73	22.53
		50	0	22.28	22.64	22.54
10M	64QAM	1	0	22.11	22.70	22.50
		1	24	20.75	21.26	21.12
		1	49	18.77	19.11	18.99
		25	0	21.79	22.21	22.05
		25	12	21.28	21.82	21.52
		25	25	19.65	20.27	20.15
		50	0	16.78	17.31	17.02
10M	256QAM	1	0	19.06	18.83	19.04
		1	24	18.01	18.22	18.11
		1	49	17.91	17.83	18.09
		25	0	19.11	18.69	19.07
		25	12	18.09	18.05	18.13
		25	25	17.96	17.77	18.08
		50	0	17.99	17.90	17.97

LTE Band 66						
BW	MCS Index	RB Size	RB Offset	Low	Mid	High
		Channel		131997	132322	132647
		Frequency (MHz)		1712.5	1745	1777.5
5M	QPSK	1	0	23.22	23.67	23.50
		1	12	22.97	23.51	23.27
		1	24	22.95	23.55	23.31
		12	0	22.64	23.09	22.72
		12	6	22.95	23.43	23.04
		12	13	22.61	23.13	22.93
		25	0	22.62	23.01	23.00
5M	16QAM	1	0	23.46	23.71	23.54
		1	12	22.95	23.44	23.21
		1	24	22.99	23.61	23.57
		12	0	22.22	22.60	22.65
		12	6	23.75	23.73	23.62
		12	13	22.19	22.71	22.52
		25	0	22.14	22.59	22.61
5M	64QAM	1	0	22.11	22.73	22.43
		1	12	20.75	21.16	21.11
		1	24	18.66	19.29	19.13
		12	0	21.78	22.23	22.04
		12	6	21.25	21.78	21.56
		12	13	19.68	20.18	20.03
		25	0	16.73	17.11	16.95
5M	256QAM	1	0	19.09	18.73	19.05
		1	12	18.07	18.08	18.20
		1	24	17.83	17.89	17.94
		12	0	19.12	18.69	19.05
		12	6	18.03	18.11	18.01
		12	13	17.76	17.91	18.01
		25	0	17.79	17.86	17.94

LTE Band 66						
BW	MCS Index	RB Size	RB Offset	Low	Mid	High
		Channel		131987	132322	132657
		Frequency (MHz)		1711.5	1745	1778.5
3M	QPSK	1	0	23.19	23.28	23.24
		1	7	23.14	23.19	23.20
		1	14	22.98	23.01	23.12
		8	0	22.90	23.07	23.12
		8	3	22.88	22.92	22.97
		8	7	22.88	22.92	22.95
		15	0	22.92	23.01	23.02
3M	16QAM	1	0	23.17	22.77	23.19
		1	7	22.12	22.17	22.18
		1	14	21.96	21.99	22.10
		8	0	21.88	22.05	22.10
		8	3	21.86	21.90	21.95
		8	7	21.86	21.90	21.93
		15	0	21.90	21.99	22.00
3M	64QAM	1	0	22.13	21.73	22.15
		1	7	21.08	21.13	21.14
		1	14	20.92	20.95	21.06
		8	0	20.84	21.01	21.06
		8	3	20.82	20.86	20.91
		8	7	20.82	20.86	20.89
		15	0	20.86	20.95	20.96
3M	256QAM	1	0	19.11	18.71	19.13
		1	7	18.06	18.11	18.12
		1	14	17.90	17.93	18.04
		8	0	19.06	18.66	19.08
		8	3	18.01	18.06	18.07
		8	7	17.85	17.88	17.99
		15	0	17.89	17.90	17.93

LTE Band 66						
BW	MCS Index	RB Size	RB Offset	Low	Mid	High
		Channel		131979	132322	132665
		Frequency (MHz)		1710.7	1745	1779.3
1.4M	QPSK	1	0	23.16	23.59	23.47
		1	2	22.96	23.48	23.13
		1	5	23.08	23.49	23.32
		3	0	23.70	24.24	23.82
		3	1	23.79	24.43	24.26
		3	3	23.74	24.00	23.95
		6	0	22.63	23.06	23.04
1.4M	16QAM	1	0	23.37	23.81	23.48
		1	2	22.76	23.45	23.27
		1	5	23.06	23.63	23.41
		3	0	23.21	23.55	23.74
		3	1	24.62	24.60	24.73
		3	3	23.24	23.77	23.71
		6	0	22.10	22.53	22.51
1.4M	64QAM	1	0	22.41	22.83	22.48
		1	2	21.87	22.51	22.24
		1	5	21.97	22.60	22.45
		3	0	22.17	22.64	22.67
		3	1	23.63	23.70	23.75
		3	3	22.23	22.66	22.57
		6	0	21.20	21.56	21.58
1.4M	256QAM	1	0	19.15	19.67	19.49
		1	2	17.63	18.24	18.05
		1	5	15.66	16.18	16.07
		3	0	19.81	20.20	19.99
		3	1	19.31	19.67	19.46
		3	3	17.69	18.16	18.06
		6	0	14.72	15.23	15.09

**ERP / EIRP Power (dBm)**

NR Band 71						
BW	MCS Index	RB Size	RB Offset	Low	Mid	High
		Channel		134600	136100	137600
		Frequency (MHz)		673	680.5	688
20M	$\pi/2$ BPSK	1	1	22.72	22.66	22.52
20M	QPSK	1	1	22.77	22.67	22.67
		1	53	22.76	22.72	22.66
		1	104	22.74	22.70	22.64
		50	0	21.68	21.67	21.61
		50	28	21.71	21.64	21.58
		50	56	21.68	21.64	21.58
		100	0	21.73	21.69	21.63
20M	16QAM	1	1	21.60	21.56	21.50
20M	64QAM	1	1	19.68	19.64	19.58
20M	256QAM	1	1	18.18	18.14	18.08
BW	MCS Index	Channel		134100	136100	138100
		Frequency (MHz)		670.5	680.5	690.5
15M	$\pi/2$ BPSK	1	1	22.69	22.64	22.57
15M	QPSK	1	1	22.62	22.71	22.65
		1	40	22.72	22.60	22.57
		1	77	22.66	22.52	22.47
		36	0	21.64	21.65	21.50
		36	22	21.49	21.46	21.50
		36	43	21.60	21.58	21.40
		75	0	21.67	21.63	21.56
15M	16QAM	1	1	21.54	21.52	21.48
15M	64QAM	1	1	19.67	19.56	19.48
15M	256QAM	1	1	18.11	18.05	17.99
BW	MCS Index	Channel		133600	136100	138600
		Frequency (MHz)		668	680.5	693
10M	$\pi/2$ BPSK	1	1	22.69	22.62	22.52
10M	QPSK	1	1	22.65	22.60	22.52
		1	26	22.72	22.65	22.53
		1	50	22.57	22.58	22.57
		25	0	21.55	21.64	21.47
		25	14	21.54	21.58	21.50
		25	27	21.59	21.46	21.54
		50	0	21.67	21.59	21.52
10M	16QAM	1	1	21.58	21.50	21.44
10M	64QAM	1	1	19.61	19.59	19.56
10M	256QAM	1	1	18.09	18.12	18.08

NR Band 71						
BW	MCS Index	RB Size	RB Offset	Low	Mid	High
		Channel		133100	136100	139100
		Frequency (MHz)		665.5	680.5	695.5
5M	$\pi/2$ BPSK	1	1	22.68	22.71	22.62
5M	QPSK	1	1	22.59	22.63	22.57
		1	13	22.68	22.60	22.51
		1	23	22.56	22.63	22.53
		12	0	21.57	21.63	21.48
		12	7	21.57	21.57	21.47
		12	13	21.57	21.59	21.41
		25	0	21.69	21.56	21.47
5M	16QAM	1	1	21.56	21.52	21.50
5M	64QAM	1	1	19.58	19.54	19.55
5M	256QAM	1	1	18.18	18.08	18.00

LTE Band 2						
BW	MCS Index	RB Size	RB Offset	Low	Mid	High
		Channel		18700	18900	19100
		Frequency (MHz)		1860	1880	1900
20M	QPSK	1	0	24.78	24.74	24.71
		1	50	24.72	24.71	24.63
		1	99	24.70	24.66	24.55
		50	0	23.90	23.90	23.79
		50	25	23.86	23.77	23.76
		50	50	23.76	23.74	23.77
		100	0	23.80	23.72	23.67
20M	16QAM	1	0	23.91	23.81	23.82
		1	50	23.84	23.86	23.76
		1	99	23.80	23.83	23.79
		50	0	22.80	22.82	22.80
		50	25	22.74	22.72	22.72
		50	50	22.79	22.74	22.73
		100	0	22.72	22.70	22.66
20M	64QAM	1	0	22.72	22.68	22.72
		1	50	22.73	22.73	22.60
		1	99	22.76	22.65	22.65
		50	0	21.96	21.87	21.88
		50	25	21.91	21.78	21.73
		50	50	21.86	21.80	21.76
		100	0	21.84	21.80	21.72
20M	256QAM	1	0	19.83	19.82	19.75
		1	50	19.91	19.85	19.82
		1	99	19.78	19.72	19.72
		50	0	19.81	19.82	19.74
		50	25	19.83	19.81	19.75
		50	50	19.82	19.75	19.69
		100	0	19.85	19.77	19.69

LTE Band 2						
BW	MCS Index	RB Size	RB Offset	Low	Mid	High
		Channel		18675	18900	19125
		Frequency (MHz)		1857.5	1880	1902.5
15M	QPSK	1	0	24.75	24.67	24.61
		1	37	24.63	24.72	24.51
		1	74	24.59	24.61	24.49
		36	0	23.87	23.78	23.74
		36	19	23.75	23.71	23.78
		36	39	23.77	23.74	23.64
		75	0	23.81	23.77	23.73
15M	16QAM	1	0	23.74	23.75	23.70
		1	37	23.75	23.83	23.67
		1	74	23.72	23.69	23.68
		36	0	22.77	22.73	22.62
		36	19	22.68	22.71	22.58
		36	39	22.65	22.62	22.67
		75	0	22.63	22.66	22.53
15M	64QAM	1	0	22.76	22.63	22.67
		1	37	22.58	22.68	22.52
		1	74	22.61	22.58	22.59
		36	0	21.93	21.76	21.74
		36	19	21.80	21.83	21.80
		36	39	21.89	21.66	21.76
		75	0	21.81	21.69	21.71
15M	256QAM	1	0	19.78	19.68	19.73
		1	37	19.84	19.72	19.70
		1	74	19.74	19.72	19.61
		36	0	19.81	19.65	19.69
		36	19	19.77	19.66	19.58
		36	39	19.63	19.75	19.73
		75	0	19.80	19.68	19.67



LTE Band 2						
BW	MCS Index	RB Size	RB Offset	Low	Mid	High
		Channel		18650	18900	19150
		Frequency (MHz)		1855	1880	1905
10M	QPSK	1	0	24.73	24.57	24.65
		1	24	24.64	24.59	24.41
		1	49	24.64	24.46	24.40
		25	0	23.88	23.76	23.64
		25	12	23.81	23.77	23.59
		25	25	23.80	23.69	23.52
		50	0	23.79	23.58	23.57
10M	16QAM	1	0	23.79	23.70	23.75
		1	24	23.65	23.65	23.63
		1	49	23.77	23.64	23.62
		25	0	22.75	22.77	22.71
		25	12	22.68	22.62	22.63
		25	25	22.80	22.55	22.64
		50	0	22.63	22.72	22.59
10M	64QAM	1	0	22.64	22.71	22.54
		1	24	22.59	22.66	22.59
		1	49	22.54	22.63	22.57
		25	0	21.94	21.74	21.83
		25	12	21.69	21.71	21.60
		25	25	21.74	21.67	21.67
		50	0	21.70	21.67	21.55
10M	256QAM	1	0	19.83	19.81	19.74
		1	24	19.77	19.76	19.65
		1	49	19.79	19.57	19.58
		25	0	19.79	19.67	19.63
		25	12	19.87	19.82	19.63
		25	25	19.71	19.73	19.67
		50	0	19.84	19.69	19.74

LTE Band 2						
BW	MCS Index	RB Size	RB Offset	Low	Mid	High
		Channel		18625	18900	19175
		Frequency (MHz)		1852.5	1880	1907.5
5M	QPSK	1	0	24.75	24.71	24.52
		1	12	24.71	24.62	24.41
		1	24	24.70	24.52	24.49
		12	0	23.79	23.76	23.68
		12	6	23.80	23.85	23.66
		12	13	23.66	23.82	23.53
		25	0	23.81	23.72	23.53
5M	16QAM	1	0	23.74	23.70	23.68
		1	12	23.86	23.70	23.70
		1	24	23.72	23.67	23.70
		12	0	22.76	22.65	22.65
		12	6	22.69	22.64	22.71
		12	13	22.76	22.66	22.66
		25	0	22.70	22.61	22.62
5M	64QAM	1	0	22.65	22.62	22.57
		1	12	22.55	22.62	22.59
		1	24	22.70	22.73	22.54
		12	0	21.80	21.86	21.85
		12	6	21.79	21.79	21.71
		12	13	21.88	21.78	21.65
		25	0	21.73	21.64	21.74
5M	256QAM	1	0	19.78	19.67	19.75
		1	12	19.71	19.74	19.76
		1	24	19.77	19.56	19.51
		12	0	19.68	19.62	19.69
		12	6	19.76	19.70	19.57
		12	13	19.58	19.68	19.58
		25	0	19.73	19.70	19.62

LTE Band 2						
BW	MCS Index	RB Size	RB Offset	Low	Mid	High
		Channel		18615	18900	19185
		Frequency (MHz)		1851.5	1880	1908.5
3M	QPSK	1	0	24.76	24.75	24.66
		1	7	24.72	24.65	24.53
		1	14	24.57	24.50	24.44
		8	0	23.77	23.78	23.71
		8	3	23.71	23.84	23.72
		8	7	23.74	23.61	23.63
		15	0	23.71	23.79	23.60
3M	16QAM	1	0	23.88	23.79	23.62
		1	7	23.78	23.74	23.74
		1	14	23.68	23.78	23.68
		8	0	22.76	22.76	22.76
		8	3	22.64	22.64	22.64
		8	7	22.68	22.62	22.53
		15	0	22.74	22.55	22.65
3M	64QAM	1	0	22.73	22.65	22.65
		1	7	22.73	22.59	22.61
		1	14	22.65	22.55	22.65
		8	0	21.80	21.82	21.74
		8	3	21.87	21.72	21.62
		8	7	21.71	21.70	21.63
		15	0	21.76	21.62	21.63
3M	256QAM	1	0	19.82	19.76	19.67
		1	7	19.73	19.83	19.62
		1	14	19.70	19.63	19.63
		8	0	19.73	19.68	19.63
		8	3	19.85	19.68	19.61
		8	7	19.72	19.65	19.58
		15	0	19.77	19.67	19.59

LTE Band 2						
BW	MCS Index	RB Size	RB Offset	Low	Mid	High
		Channel		18607	18900	19193
		Frequency (MHz)		1850.7	1880	1909.3
1.4M	QPSK	1	0	24.71	24.69	24.66
		1	2	24.64	24.55	24.68
		1	5	24.56	24.61	24.46
		3	0	24.91	24.70	24.72
		3	1	24.82	24.66	24.75
		3	3	24.72	24.76	24.56
		6	0	23.79	23.68	23.67
1.4M	16QAM	1	0	23.71	23.73	23.78
		1	2	23.79	23.67	23.71
		1	5	23.77	23.71	23.63
		3	0	23.82	23.83	23.60
		3	1	23.64	23.73	23.62
		3	3	23.63	23.64	23.70
		6	0	22.61	22.63	22.48
1.4M	64QAM	1	0	22.83	22.85	22.69
		1	2	22.72	22.74	22.71
		1	5	22.74	22.69	22.64
		3	0	22.82	22.73	22.61
		3	1	22.63	22.71	22.71
		3	3	22.73	22.57	22.68
		6	0	21.73	21.53	21.47
1.4M	256QAM	1	0	19.71	19.75	19.63
		1	2	19.75	19.64	19.60
		1	5	19.65	19.62	19.65
		3	0	19.94	19.79	19.88
		3	1	19.80	19.70	19.67
		3	3	19.76	19.74	19.80
		6	0	19.74	19.73	19.66

LTE Band 66						
BW	MCS Index	RB Size	RB Offset	Low	Mid	High
		Channel		132072	132322	132572
		Frequency (MHz)		1720	1745	1770
20M	QPSK	1	0	26.46	26.82	26.78
		1	50	26.09	26.67	26.51
		1	99	26.22	26.69	26.58
		50	0	25.99	26.36	26.15
		50	25	26.12	26.68	26.50
		50	50	25.90	26.37	26.22
		100	0	25.98	26.32	26.25
20M	16QAM	1	0	26.70	27.04	26.75
		1	50	26.10	26.74	26.52
		1	99	26.30	26.77	26.72
		50	0	25.41	25.87	25.84
		50	25	26.95	26.97	26.88
		50	50	25.47	25.93	25.85
		100	0	25.40	25.91	25.83
20M	64QAM	1	0	25.39	25.84	25.69
		1	50	23.92	24.45	24.27
		1	99	21.98	22.46	22.34
		50	0	25.06	25.38	25.35
		50	25	24.44	24.93	24.76
		50	50	22.92	23.49	23.26
		100	0	19.97	20.43	20.31
20M	256QAM	1	0	22.36	21.93	22.38
		1	50	21.33	21.37	21.39
		1	99	21.13	21.15	21.26
		50	0	22.26	21.94	22.27
		50	25	21.26	21.30	21.35
		50	50	21.04	21.13	21.21
		100	0	21.09	21.12	21.14

LTE Band 66						
BW	MCS Index	RB Size	RB Offset	Low	Mid	High
		Channel		132047	132322	132597
		Frequency (MHz)		1717.5	1745	1772.5
15M	QPSK	1	0	26.36	26.89	26.65
		1	37	26.15	26.48	26.47
		1	74	26.28	26.58	26.41
		36	0	25.83	26.45	26.05
		36	19	26.00	26.62	26.38
		36	39	25.88	26.14	26.13
		75	0	25.97	26.15	26.10
15M	16QAM	1	0	26.55	27.07	26.63
		1	37	26.12	26.65	26.42
		1	74	26.23	26.77	26.62
		36	0	25.37	25.79	25.82
		36	19	26.74	26.84	26.84
		36	39	25.43	25.85	25.71
		75	0	25.40	25.87	25.65
15M	64QAM	1	0	25.43	25.80	25.61
		1	37	23.86	24.40	24.28
		1	74	21.96	22.34	22.20
		36	0	25.01	25.32	25.20
		36	19	24.45	24.93	24.72
		36	39	22.81	23.38	23.26
		75	0	19.87	20.40	20.24
15M	256QAM	1	0	22.28	21.92	22.31
		1	37	21.27	21.19	21.23
		1	74	21.14	21.13	21.25
		36	0	22.28	21.92	22.23
		36	19	21.20	21.27	21.20
		36	39	21.12	21.10	21.16
		75	0	21.09	21.07	21.16

LTE Band 66						
BW	MCS Index	RB Size	RB Offset	Low	Mid	High
		Channel		132022	132322	132622
		Frequency (MHz)		1715	1745	1775
10M	QPSK	1	0	26.34	26.71	26.68
		1	24	26.04	26.66	26.25
		1	49	26.12	26.57	26.42
		25	0	25.93	26.36	25.99
		25	12	25.92	26.59	26.37
		25	25	25.88	26.17	26.13
		50	0	25.86	26.21	26.01
10M	16QAM	1	0	26.53	26.92	26.66
		1	24	26.07	26.66	26.39
		1	49	26.19	26.77	26.59
		25	0	25.34	25.77	25.79
		25	12	26.86	26.92	26.78
		25	25	25.42	25.89	25.69
		50	0	25.44	25.80	25.70
10M	64QAM	1	0	25.27	25.86	25.66
		1	24	23.91	24.42	24.28
		1	49	21.93	22.27	22.15
		25	0	24.95	25.37	25.21
		25	12	24.44	24.98	24.68
		25	25	22.81	23.43	23.31
		50	0	19.94	20.47	20.18
10M	256QAM	1	0	22.22	21.99	22.20
		1	24	21.17	21.38	21.27
		1	49	21.07	20.99	21.25
		25	0	22.27	21.85	22.23
		25	12	21.25	21.21	21.29
		25	25	21.12	20.93	21.24
		50	0	21.15	21.06	21.13

LTE Band 66						
BW	MCS Index	RB Size	RB Offset	Low	Mid	High
		Channel		131997	132322	132647
		Frequency (MHz)		1712.5	1745	1777.5
5M	QPSK	1	0	26.38	26.83	26.66
		1	12	26.13	26.67	26.43
		1	24	26.11	26.71	26.47
		12	0	25.80	26.25	25.88
		12	6	26.11	26.59	26.20
		12	13	25.77	26.29	26.09
		25	0	25.78	26.17	26.16
5M	16QAM	1	0	26.62	26.87	26.70
		1	12	26.11	26.60	26.37
		1	24	26.15	26.77	26.73
		12	0	25.38	25.76	25.81
		12	6	26.91	26.89	26.78
		12	13	25.35	25.87	25.68
		25	0	25.30	25.75	25.77
5M	64QAM	1	0	25.27	25.89	25.59
		1	12	23.91	24.32	24.27
		1	24	21.82	22.45	22.29
		12	0	24.94	25.39	25.20
		12	6	24.41	24.94	24.72
		12	13	22.84	23.34	23.19
		25	0	19.89	20.27	20.11
5M	256QAM	1	0	22.25	21.89	22.21
		1	12	21.23	21.24	21.36
		1	24	20.99	21.05	21.10
		12	0	22.28	21.85	22.21
		12	6	21.19	21.27	21.17
		12	13	20.92	21.07	21.17
		25	0	20.95	21.02	21.10



LTE Band 66						
BW	MCS Index	RB Size	RB Offset	Low	Mid	High
		Channel		131987	132322	132657
		Frequency (MHz)		1711.5	1745	1778.5
3M	QPSK	1	0	26.35	26.44	26.40
		1	7	26.30	26.35	26.36
		1	14	26.14	26.17	26.28
		8	0	26.06	26.23	26.28
		8	3	26.04	26.08	26.13
		8	7	26.04	26.08	26.11
		15	0	26.08	26.17	26.18
3M	16QAM	1	0	26.33	25.93	26.35
		1	7	25.28	25.33	25.34
		1	14	25.12	25.15	25.26
		8	0	25.04	25.21	25.26
		8	3	25.02	25.06	25.11
		8	7	25.02	25.06	25.09
		15	0	25.06	25.15	25.16
3M	64QAM	1	0	25.29	24.89	25.31
		1	7	24.24	24.29	24.30
		1	14	24.08	24.11	24.22
		8	0	24.00	24.17	24.22
		8	3	23.98	24.02	24.07
		8	7	23.98	24.02	24.05
		15	0	24.02	24.11	24.12
3M	256QAM	1	0	22.27	21.87	22.29
		1	7	21.22	21.27	21.28
		1	14	21.06	21.09	21.20
		8	0	22.22	21.82	22.24
		8	3	21.17	21.22	21.23
		8	7	21.01	21.04	21.15
		15	0	21.05	21.06	21.09

LTE Band 66						
BW	MCS Index	RB Size	RB Offset	Low	Mid	High
		Channel		131979	132322	132665
		Frequency (MHz)		1710.7	1745	1779.3
1.4M	QPSK	1	0	26.32	26.75	26.63
		1	2	26.12	26.64	26.29
		1	5	26.24	26.65	26.48
		3	0	26.86	27.40	26.98
		3	1	26.95	27.59	27.42
		3	3	26.90	27.16	27.11
		6	0	25.79	26.22	26.20
1.4M	16QAM	1	0	26.53	26.97	26.64
		1	2	25.92	26.61	26.43
		1	5	26.22	26.79	26.57
		3	0	26.37	26.71	26.90
		3	1	27.78	27.76	27.89
		3	3	26.40	26.93	26.87
		6	0	25.26	25.69	25.67
1.4M	64QAM	1	0	25.57	25.99	25.64
		1	2	25.03	25.67	25.40
		1	5	25.13	25.76	25.61
		3	0	25.33	25.80	25.83
		3	1	26.79	26.86	26.91
		3	3	25.39	25.82	25.73
		6	0	24.36	24.72	24.74
1.4M	256QAM	1	0	22.31	22.83	22.65
		1	2	20.79	21.40	21.21
		1	5	18.82	19.34	19.23
		3	0	22.97	23.36	23.15
		3	1	22.47	22.83	22.62
		3	3	20.85	21.32	21.22
		6	0	17.88	18.39	18.25

## 4.2 Modulation Characteristics Measurement

### 4.2.1 Limits of Modulation Characteristics

N/A

### 4.2.2 Test Procedure

Connect the EUT to Communication Simulator via the antenna connector, The frequency band is set as EUT supported Modulation and Channels, the EUT output is matched with 50 ohm load, the waveform quality and constellation of the EUT was tested.

### 4.2.3 Test Setup

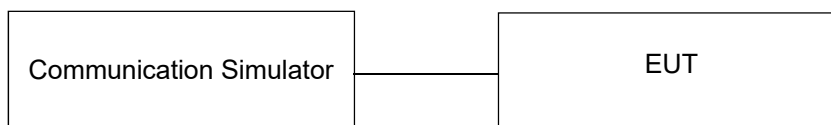

## 4.2.4 Test Results

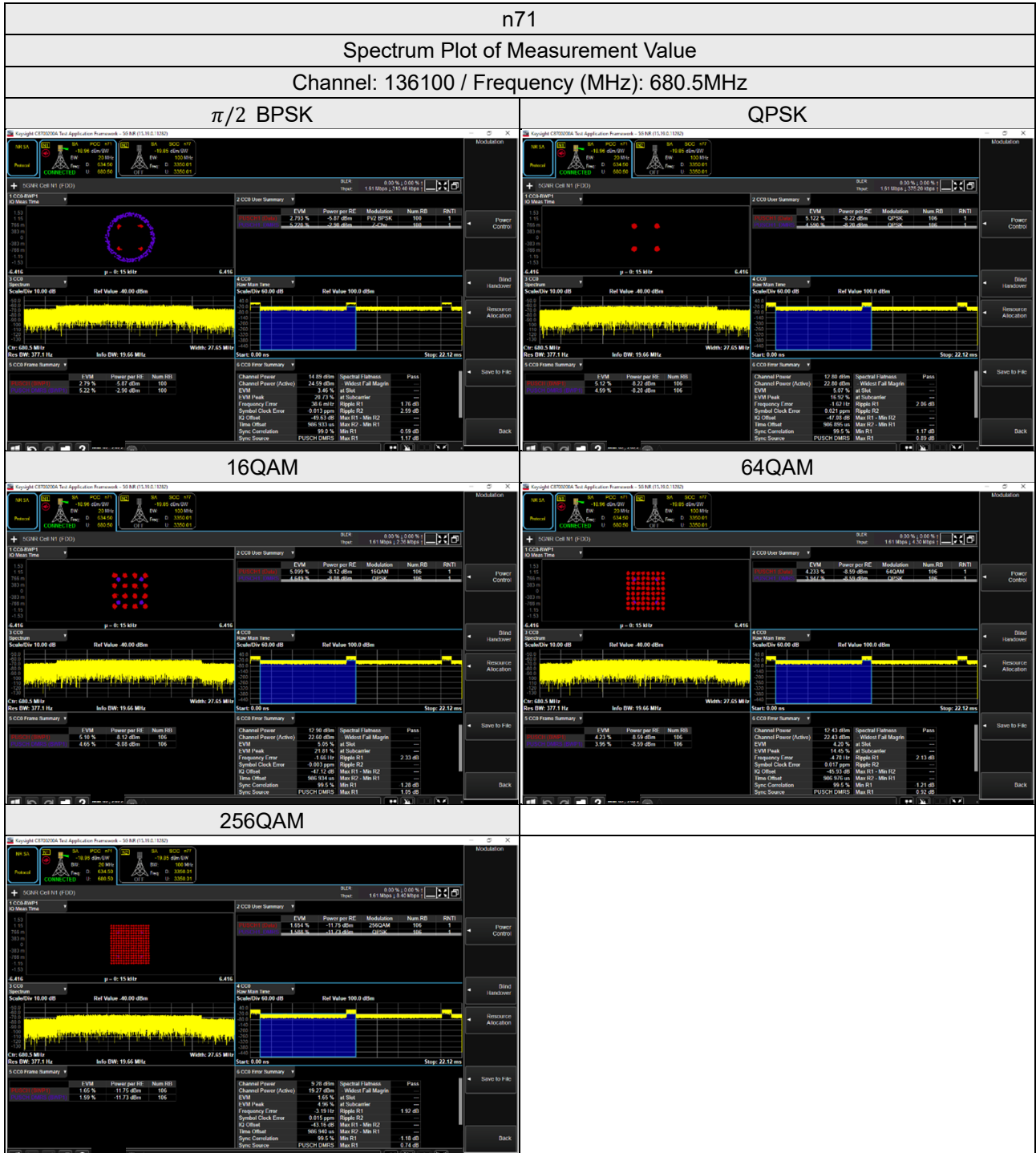

### 4.3 Frequency Stability Measurement

#### 4.3.1 Limits of Frequency Stability Measurement

According to the FCC part 2.1055 shall be tested the frequency stability. The rule is defined that "The frequency stability shall be sufficient to ensure that the fundamental emission stays within the authorized frequency block." The test extreme voltage is according to the 2.1055(d)(1) Vary primary supply voltage from 85 to 115 percent of the nominal value for other than hand carried battery equipment and the extreme temperature rule is comply with specification of EUT  $-30^{\circ}\text{C} \sim 50^{\circ}\text{C}$ .

#### 4.3.2 Test Procedure

- Device is placed at the oven room. The oven room could control the temperatures and humidity. Power warm up is at least 15 min and power applied should perform before recording frequency error.
- EUT is connected the external power supply to control the DC input power. The test voltage range is from minimum to maximum working voltage. Each step shall be record the frequency error rate.
- The temperature range step is 10 degrees in this test items. All temperature levels shall be hold the  $\pm 0.5^{\circ}\text{C}$  during the measurement testing. The each temperature step shall be at least 0.5 hours, consider the EUT could be test under the stability condition.

Note: The frequency error was recorded frequency error from the communication simulator.

#### 4.3.3 Test Setup

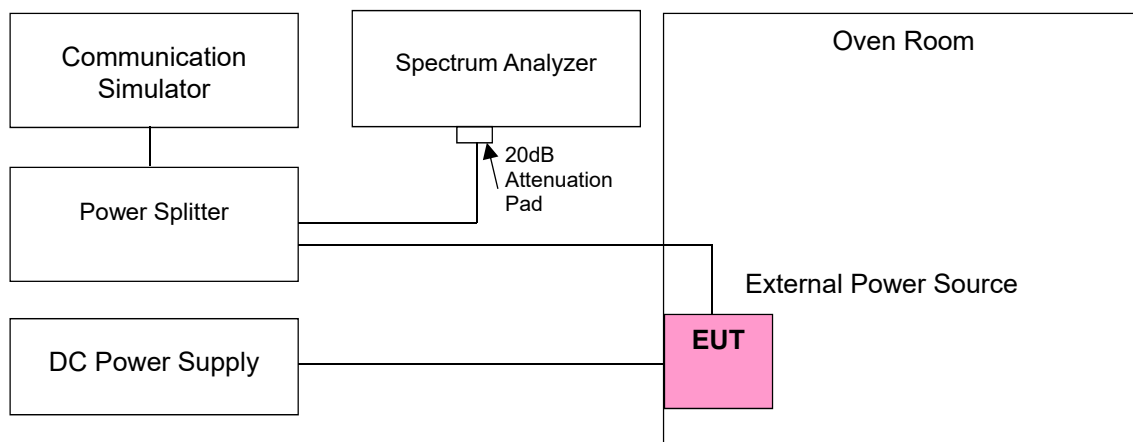

#### 4.3.4 Test Results

##### Frequency Error vs. Voltage

Voltage (Vdc)	n71			
	Channel Bandwidth 5 MHz			
	Low Channel		High Channel	
	Frequency (MHz)	Frequency Error (ppm)	Frequency (MHz)	Frequency Error (ppm)
3.85	665.500003	0.005	695.500000	0.001
3.28	665.499996	-0.006	695.500000	0.006
4.43	665.499998	-0.003	695.500000	-0.003

Note: The applicant defined the normal working voltage is from 3.28Vdc to 4.43Vdc.

##### Frequency Error vs. Temperature

Temp. (°C)	n71			
	Channel Bandwidth 5 MHz			
	Low Channel		High Channel	
	Frequency (MHz)	Frequency Error (ppm)	Frequency (MHz)	Frequency Error (ppm)
-30	665.500002	0.003	695.500000	-0.003
-20	665.499996	-0.006	695.500000	-0.001
-10	665.499997	-0.005	695.500000	0.001
0	665.499996	-0.006	695.500000	-0.004
10	665.500002	0.003	695.500000	-0.001
20	665.500004	0.006	695.500000	-0.004
30	665.500001	0.002	695.500000	0.003
40	665.499997	-0.005	695.500000	-0.004
50	665.499997	-0.005	695.500000	-0.004

Frequency Error vs. Voltage

Voltage (Vdc)	n71			
	Channel Bandwidth 10 MHz			
	Low Channel		High Channel	
	Frequency (MHz)	Frequency Error (ppm)	Frequency (MHz)	Frequency Error (ppm)
3.85	667.999996	-0.006	692.999998	-0.003
3.28	668.000001	0.002	692.999999	-0.001
4.43	668.000004	0.006	692.999997	-0.004

Note: The applicant defined the normal working voltage is from 3.28Vdc to 4.43Vdc.

Frequency Error vs. Temperature

Temp. (°C)	n71			
	Channel Bandwidth 10 MHz			
	Low Channel		High Channel	
	Frequency (MHz)	Frequency Error (ppm)	Frequency (MHz)	Frequency Error (ppm)
-30	667.999998	-0.003	693.000002	0.003
-20	667.999997	-0.005	693.000002	0.003
-10	668.000002	0.003	692.999999	-0.001
0	667.999998	-0.003	693.000001	0.001
10	668.000002	0.003	693.000002	0.003
20	668.000001	0.002	692.999997	-0.004
30	667.999999	-0.002	692.999997	-0.004
40	667.999999	-0.002	692.999999	-0.001
50	668.000002	0.003	692.999999	-0.001

Frequency Error vs. Voltage

Voltage (Vdc)	n71			
	Channel Bandwidth 15 MHz			
	Low Channel		High Channel	
	Frequency (MHz)	Frequency Error (ppm)	Frequency (MHz)	Frequency Error (ppm)
3.85	670.499996	-0.006	690.500004	0.006
3.28	670.500003	0.005	690.499997	-0.004
4.43	670.499999	-0.002	690.499999	-0.001

Note: The applicant defined the normal working voltage is from 3.28Vdc to 4.43Vdc.

Frequency Error vs. Temperature

Temp. (°C)	n71			
	Channel Bandwidth 15 MHz			
	Low Channel		High Channel	
	Frequency (MHz)	Frequency Error (ppm)	Frequency (MHz)	Frequency Error (ppm)
-30	670.500003	0.005	690.499996	-0.006
-20	670.499999	-0.002	690.499999	-0.001
-10	670.500004	0.006	690.500003	0.004
0	670.499997	-0.005	690.499999	-0.001
10	670.499998	-0.003	690.499999	-0.001
20	670.499999	-0.002	690.499998	-0.003
30	670.500003	0.005	690.499997	-0.004
40	670.499998	-0.003	690.499996	-0.006
50	670.499999	-0.002	690.499998	-0.003



## Frequency Error vs. Voltage

Voltage (Vdc)	n71			
	Channel Bandwidth 20 MHz			
	Low Channel		High Channel	
	Frequency (MHz)	Frequency Error (ppm)	Frequency (MHz)	Frequency Error (ppm)
3.85	673.000001	0.002	688.000002	0.003
3.28	672.999997	-0.005	687.999999	-0.001
4.43	672.999999	-0.002	687.999996	-0.006

Note: The applicant defined the normal working voltage is from 3.28Vdc to 4.43Vdc.

## Frequency Error vs. Temperature

Temp. (°C)	n71			
	Channel Bandwidth 20 MHz			
	Low Channel		High Channel	
	Frequency (MHz)	Frequency Error (ppm)	Frequency (MHz)	Frequency Error (ppm)
-30	673.000003	0.005	688.000003	0.004
-20	672.999999	-0.002	687.999996	-0.006
-10	673.000002	0.003	687.999996	-0.006
0	672.999999	-0.002	687.999998	-0.003
10	672.999999	-0.002	687.999999	-0.001
20	673.000003	0.005	688.000001	0.001
30	672.999997	-0.005	687.999998	-0.003
40	672.999998	-0.003	688.000003	0.004
50	672.999998	-0.003	687.999997	-0.004

## 4.4 Occupied Bandwidth Measurement

### 4.4.1 Limits of Occupied Bandwidth Measurement

The occupied bandwidth (OBW), that is the frequency bandwidth such that, below its lower and above its upper frequency limits, the mean powers radiated are each equal to 0.5 % of the total mean power radiated by a given emission.

### 4.4.2 Test Procedure

The EUT makes a call to the communication simulator. All measurements were done at low, middle and high operational frequency range. The communication simulator station system controlled a EUT to export maximum output power under transmission mode and specific channel frequency. Measurement method, please refer to section 5.4.4 of ANSI C63.26. Use OBW measurement function of Spectrum analyzer to measure 99 % occupied bandwidth.

For the 26dBc bandwidth measurement method, please refer to section 5.4.3 of ANSI C63.26.

### 4.4.3 Test Setup

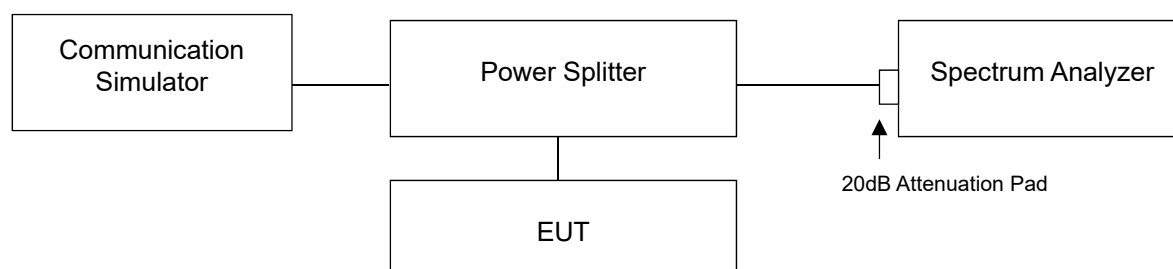

#### 4.4.4 Test Result

##### Occupied Bandwidth

n71, Channel Bandwidth 5MHz						
Channel	Frequency (MHz)	99% Occupied Bandwidth (MHz)				
		$\pi/2$ BPSK	QPSK	16QAM	64QAM	256QAM
133100	665.5	4.47	4.46	4.46	4.46	4.46
136100	680.5	4.47	4.46	4.46	4.46	4.46
139100	695.5	4.46	4.46	4.46	4.46	4.46
n71, Channel Bandwidth 10MHz						
Channel	Frequency (MHz)	99% Occupied Bandwidth (MHz)				
		$\pi/2$ BPSK	QPSK	16QAM	64QAM	256QAM
133600	668.0	8.92	8.93	8.92	8.93	8.93
136100	680.5	8.92	8.93	8.92	8.93	8.94
138600	693.0	8.91	8.91	8.91	8.91	8.92
n71 Channel Bandwidth 15MHz						
Channel	Frequency (MHz)	99% Occupied Bandwidth (MHz)				
		$\pi/2$ BPSK	QPSK	16QAM	64QAM	256QAM
134100	670.5	13.37	13.35	13.37	13.38	13.37
136100	680.5	13.40	13.38	13.39	13.40	13.40
138100	690.5	13.36	13.34	13.35	13.36	13.35
n71, Channel Bandwidth 20MHz						
Channel	Frequency (MHz)	99% Occupied Bandwidth (MHz)				
		$\pi/2$ BPSK	QPSK	16QAM	64QAM	256QAM
134600	673.0	17.79	17.80	17.84	17.81	17.82
136100	680.5	17.84	17.85	17.88	17.85	17.87
137600	688.0	17.79	17.81	17.84	17.81	17.83

### Spectrum Plot of Worst Value

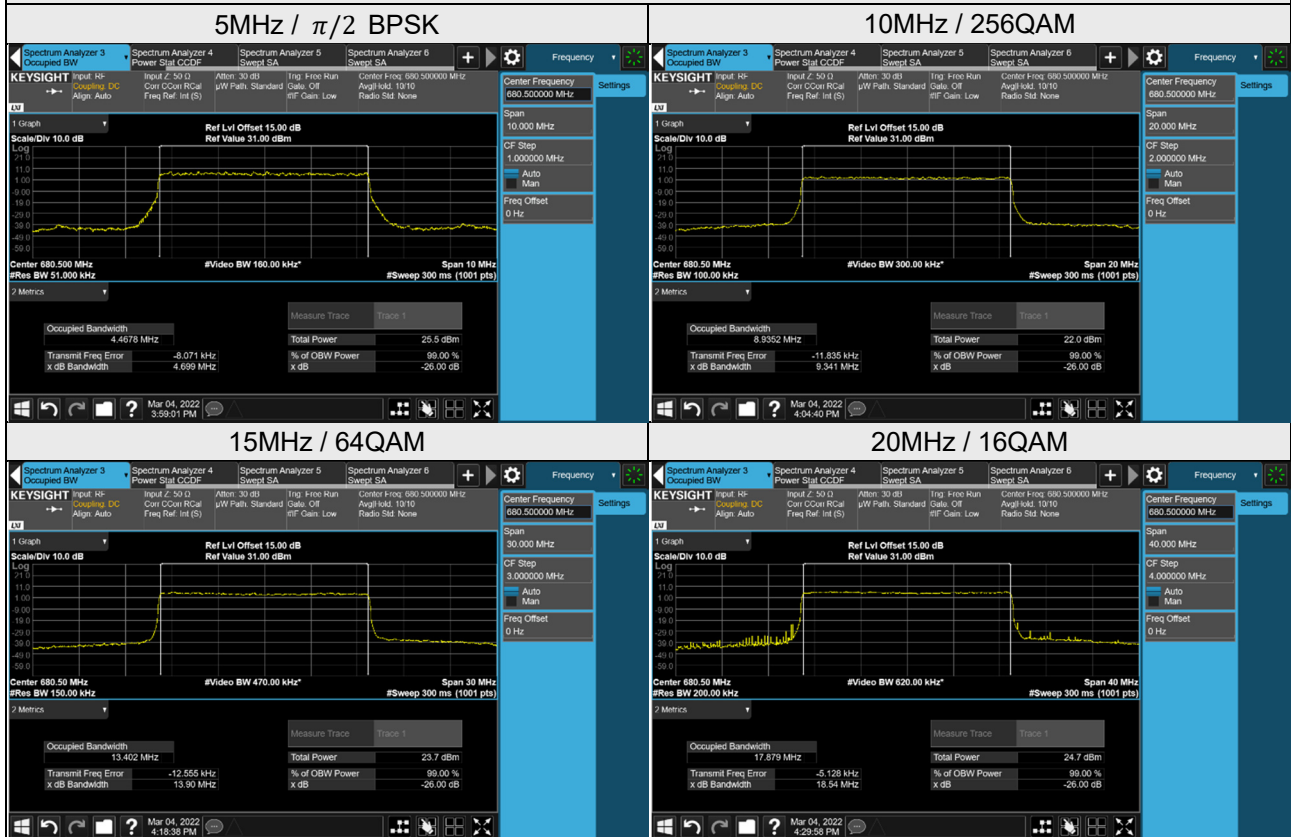

### 26dB Bandwidth

n71, Channel Bandwidth 5MHz						
Channel	Frequency (MHz)	26dB Bandwidth (MHz)				
		$\pi/2$ BPSK	QPSK	16QAM	64QAM	256QAM
133100	665.5	4.71	4.74	4.74	4.70	4.71
136100	680.5	4.70	4.74	4.72	4.70	4.72
139100	695.5	4.68	4.73	4.73	4.69	4.71
n71, Channel Bandwidth 10MHz						
Channel	Frequency (MHz)	26dB Bandwidth (MHz)				
		$\pi/2$ BPSK	QPSK	16QAM	64QAM	256QAM
133600	668.0	9.26	9.30	9.33	9.33	9.33
136100	680.5	9.29	9.27	9.34	9.34	9.34
138600	693.0	9.28	9.29	9.28	9.31	9.29
n71 Channel Bandwidth 15MHz						
Channel	Frequency (MHz)	26dB Bandwidth (MHz)				
		$\pi/2$ BPSK	QPSK	16QAM	64QAM	256QAM
134100	670.5	13.87	13.90	13.87	13.89	13.89
136100	680.5	13.91	13.91	13.88	13.90	13.91
138100	690.5	13.87	13.89	13.87	13.88	13.88
n71, Channel Bandwidth 20MHz						
Channel	Frequency (MHz)	26dB Bandwidth (MHz)				
		$\pi/2$ BPSK	QPSK	16QAM	64QAM	256QAM
134600	673.0	18.52	18.48	18.50	18.51	18.53
136100	680.5	18.55	18.52	18.54	18.53	18.56
137600	688.0	18.50	18.49	18.51	18.51	18.53

### Spectrum Plot of Worst Value

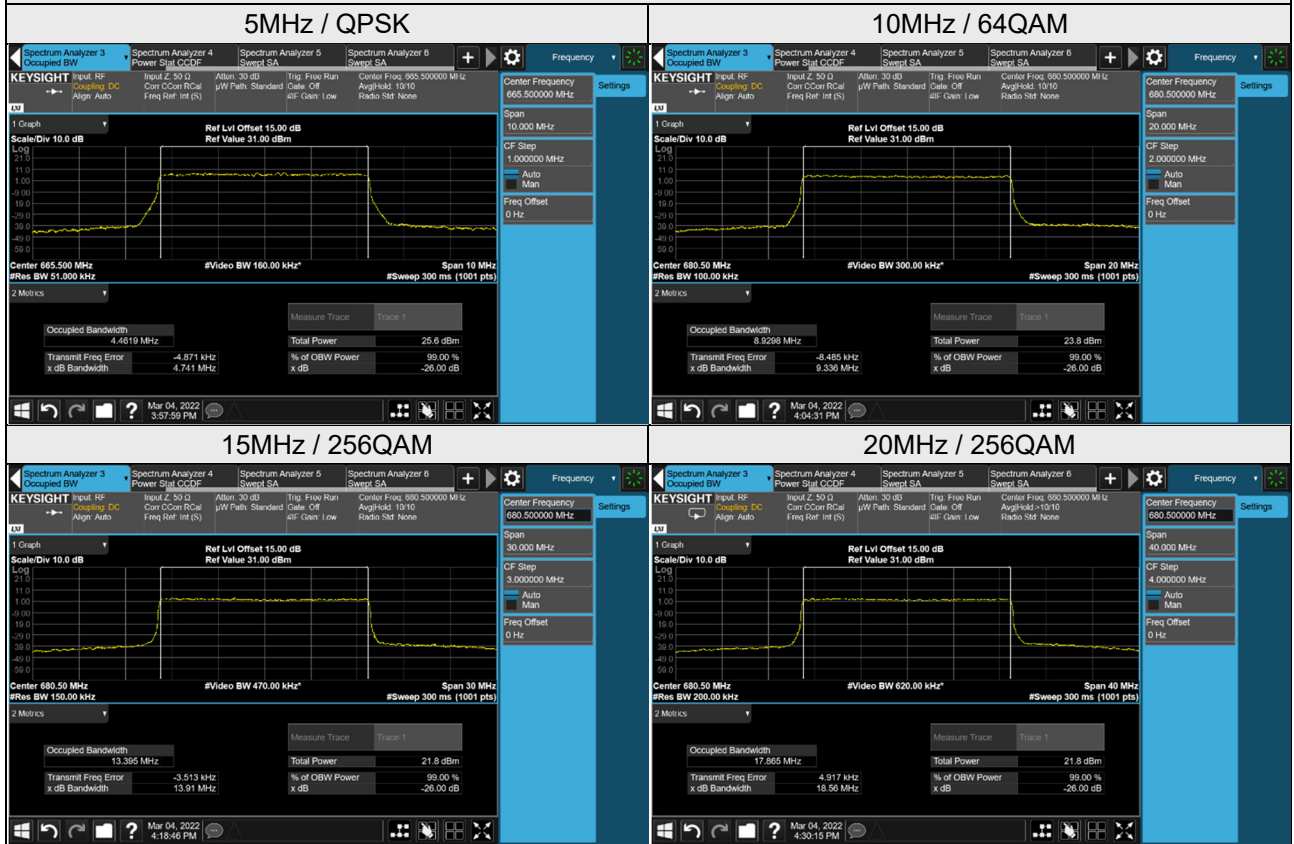

## 4.5 Band Edge Measurement

### 4.5.1 Limits of Band Edge Measurement

According to FCC 27.53(g) for operations in the 600 MHz band and the 698-746 MHz band, the power of any emission outside a licensee's frequency band(s) of operation shall be attenuated below the transmitter power (P) within the licensed band(s) of operation, measured in watts, by at least  $43 + 10 \log (P)$  dB. Compliance with this provision is based on the use of measurement instrumentation employing a resolution bandwidth of 100 kilohertz or greater.

### 4.5.2 Test Setup

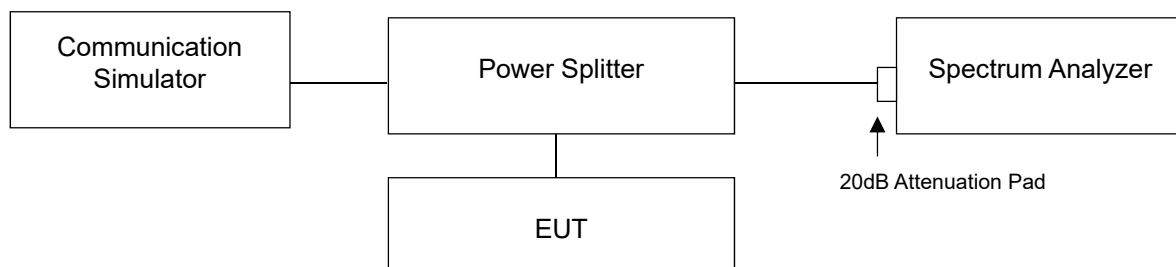

### 4.5.3 Test Procedures

- a. The testing follows ANSI C63.26 section 5.7
- b. The EUT was connected to spectrum analyzer and system simulator via a power divider.
- c. The band edges of low and high channels for the highest RF powers were measured.
- d. Set RBW  $\geq$  1% EBW in the 1MHz band immediately outside and adjacent to the band edge.
- e. Beyond the 1 MHz band from the band edge, RBW=100kHz or 1MHz was used.
- f. Set spectrum analyzer with RMS detector.
- g. Checked that all the results comply with the emission limit line.

### 4.5.4 Test Results

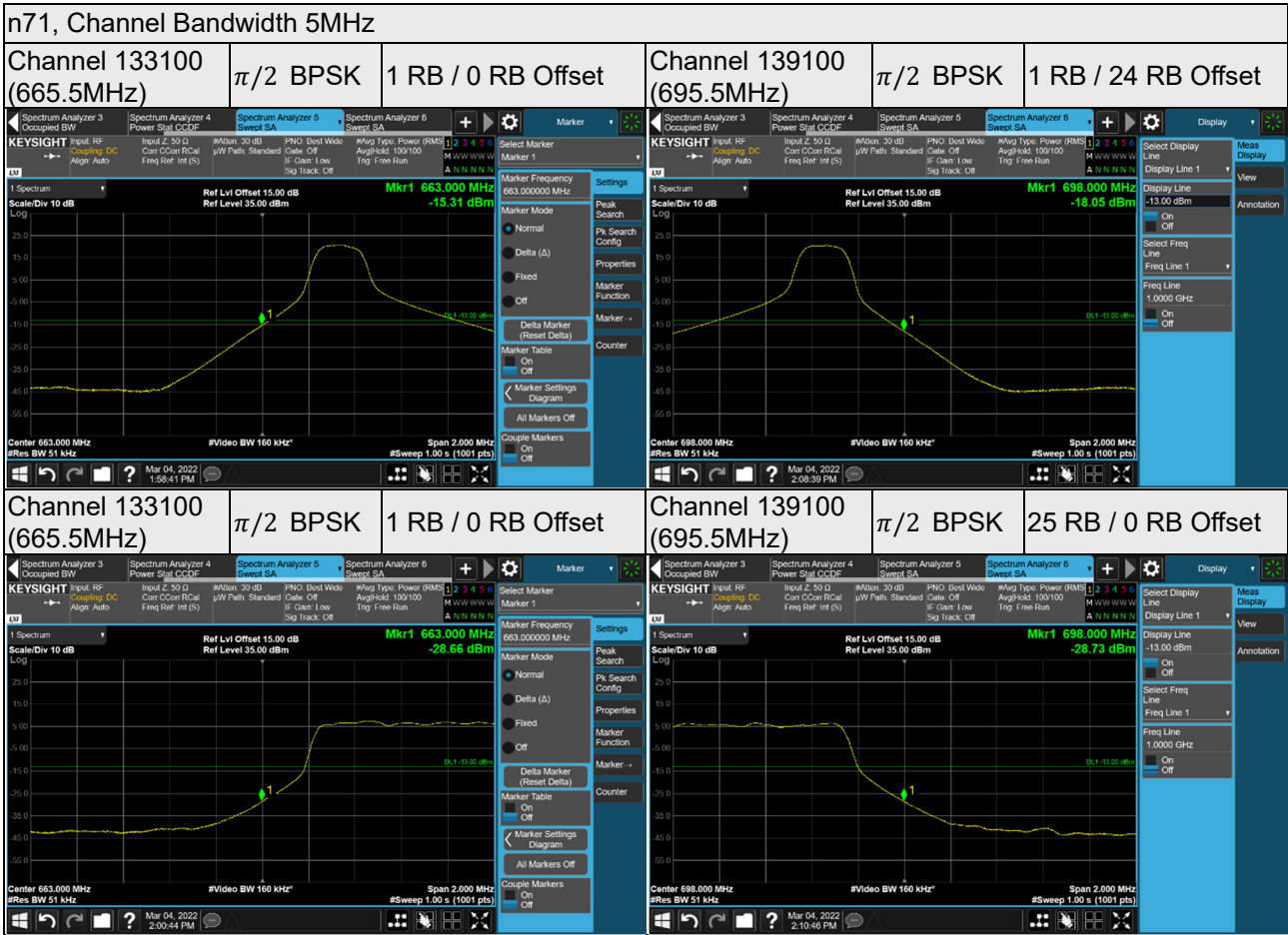



n71, Channel Bandwidth 10MHz

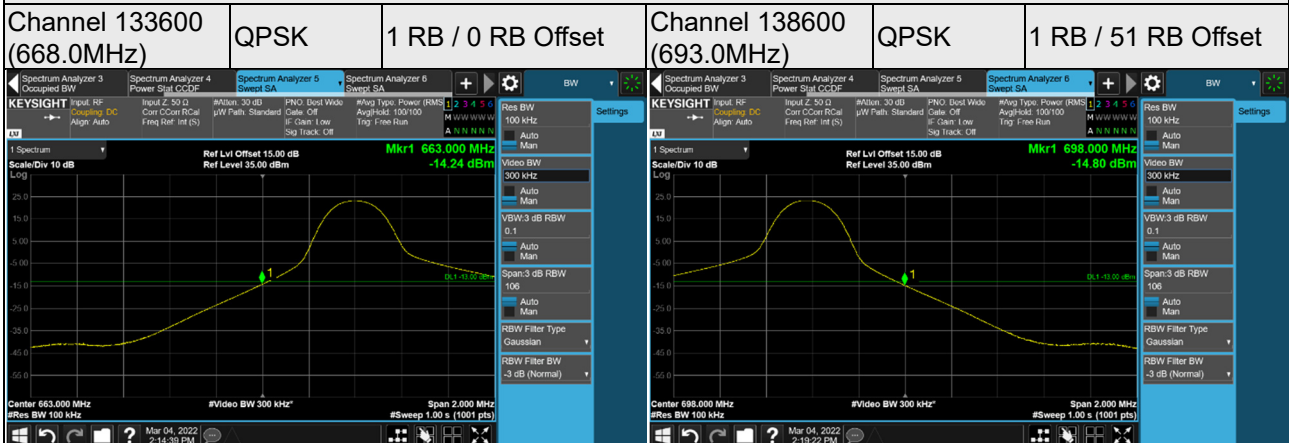

n71, Channel Bandwidth 15MHz

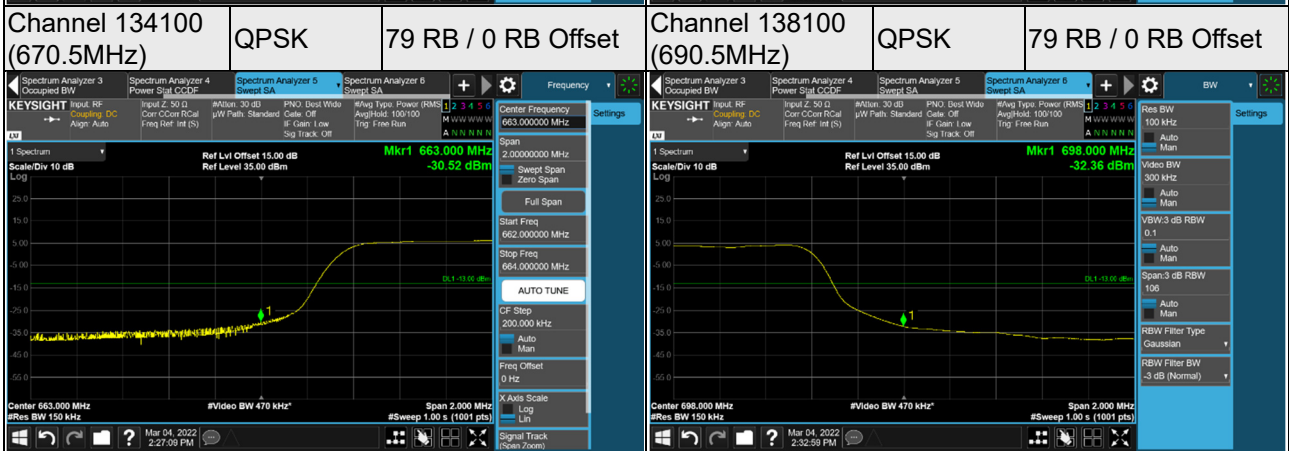
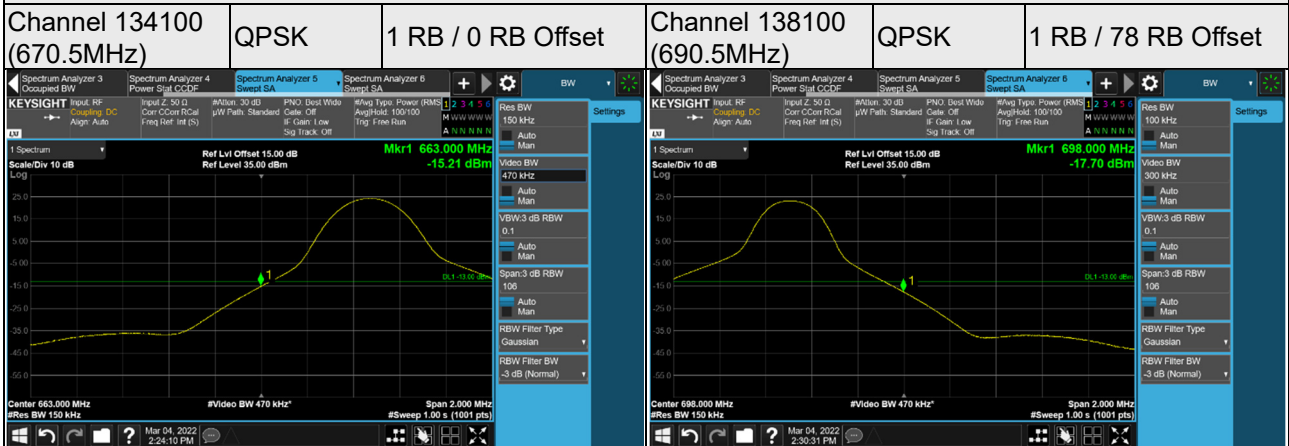

n71, Channel Bandwidth 20MHz

Channel 134600 (673.0MHz)	QPSK	1 RB / 0 RB Offset	Channel 137600 (688.0MHz)	QPSK	1 RB / 105 RB Offset
------------------------------	------	--------------------	------------------------------	------	----------------------

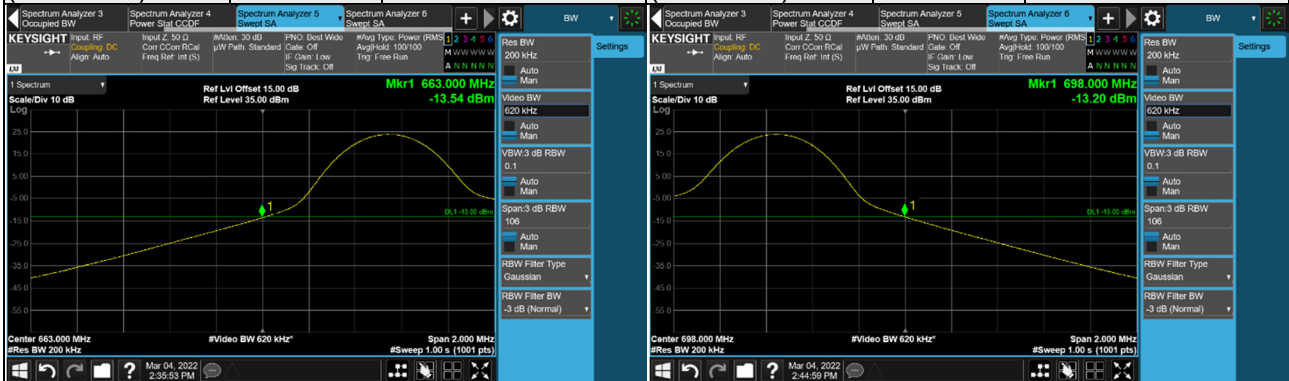

Channel 134600 (673.0MHz)	QPSK	106 RB / 0 RB Offset	Channel 137600 (688.0MHz)	QPSK	106 RB / 0 RB Offset
------------------------------	------	----------------------	------------------------------	------	----------------------

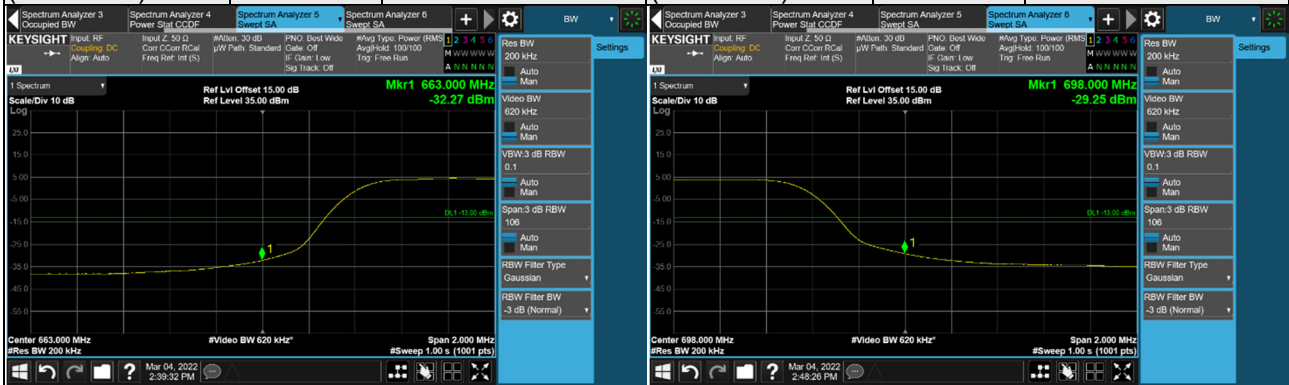

## 4.6 Peak to Average Ratio

### 4.6.1 Limits of Peak to Average Ratio Measurement

In measuring transmissions in this band using an average power technique, the peak to-average ratio (PAR) of the transmission may not exceed 13 dB

### 4.6.2 Test Setup

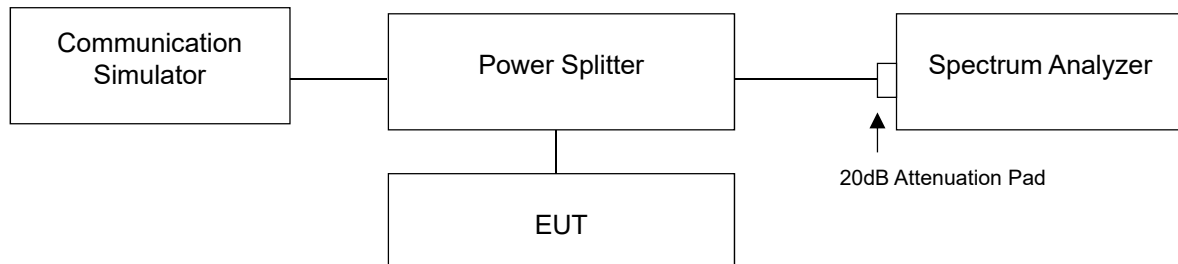

### 4.6.3 Test Procedures

- Set resolution/measurement bandwidth  $\geq$  signal's occupied bandwidth;
- Set the number of counts to a value that stabilizes the measured CCDF curve;
- Record the maximum PAPR level associated with a probability of 0.1%.

#### 4.6.4 Test Results

n71, Channel Bandwidth 5MHz						
Channel	Frequency (MHz)	Peak To Average Ratio (dB)				
		$\pi/2$ BPSK	QPSK	16QAM	64QAM	256QAM
133100	665.5	4.28	4.88	5.36	6.35	6.38
136100	680.5	4.35	5.17	5.71	6.63	6.34
139100	695.5	4.17	4.85	5.30	6.35	6.25
n71, Channel Bandwidth 10MHz						
Channel	Frequency (MHz)	Peak To Average Ratio (dB)				
		$\pi/2$ BPSK	QPSK	16QAM	64QAM	256QAM
133600	668.0	4.16	4.90	5.42	6.38	6.41
136100	680.5	4.33	5.07	5.52	6.56	6.35
138600	693.0	4.36	5.14	5.57	6.61	6.40
n71 Channel Bandwidth 15MHz						
Channel	Frequency (MHz)	Peak To Average Ratio (dB)				
		$\pi/2$ BPSK	QPSK	16QAM	64QAM	256QAM
134100	670.5	4.20	4.98	5.46	6.45	6.41
136100	680.5	4.38	5.20	5.60	6.66	6.41
138100	690.5	4.45	5.33	5.71	6.77	6.43
n71, Channel Bandwidth 20MHz						
Channel	Frequency (MHz)	Peak To Average Ratio (dB)				
		$\pi/2$ BPSK	QPSK	16QAM	64QAM	256QAM
134600	673.0	4.37	5.36	5.76	6.62	6.59
136100	680.5	4.38	5.19	5.59	6.66	6.39
137600	688.0	4.41	5.28	5.82	6.73	6.39