

FCC Test Report (Part 27 – 5G NR n41/n66/n71)

Report No.: RFBCKT-WTW-P21031102-9

FCC ID: HFSQTAD53

Test Model: QTAD53

Received Date: Mar. 31, 2021

Test Date: Apr. 28 ~ May 25, 2021

Issued Date: May 25, 2021

Applicant: QUANTA COMPUTER INC

Address: No. 211, Wenhua 2nd Rd., Guishan Dist., Taoyuan City 33377, Taiwan

Issued By: Bureau Veritas Consumer Products Services (H.K.) Ltd., Taoyuan Branch
Lin Kou Laboratories

Lab Address: No. 47-2, 14th Ling, Chia Pau Vil., Lin Kou Dist., New Taipei City, Taiwan

Test Location: No. 19, Hwa Ya 2nd Rd., Wen Hwa Vil., Kwei Shan Dist., Taoyuan City
33383, TAIWAN

**FCC Registration /
Designation Number:** 788550 / TW0003



This report is for your exclusive use. Any copying or replication of this report to or for any other person or entity, or use of our name or trademark, is permitted only with our prior written permission. This report sets forth our findings solely with respect to the test samples identified herein. The results set forth in this report are not indicative or representative of the quality or characteristics of the lot from which a test sample was taken or any similar or identical product unless specifically and expressly noted. Our report includes all of the tests requested by you and the results thereof based upon the information that you provided to us. You have 60 days from date of issuance of this report to notify us of any material error or omission caused by our negligence, provided, however, that such notice shall be in writing and shall specifically address the issue you wish to raise. A failure to raise such issue within the prescribed time shall constitute your unqualified acceptance of the completeness of this report, the tests conducted and the correctness of the report contents. Unless specifically mentioned, the uncertainty of measurement has been explicitly taken into account to declare the compliance or non-compliance to the specification.

Table of Contents

Release Control Record	4
1 Certificate of Conformity	5
2 Summary of Test Results	6
2.1 Measurement Uncertainty.....	6
2.2 Test Site and Instruments.....	7
3 General Information	8
3.1 General Description of EUT.....	8
3.2 Configuration of System under Test.....	11
3.2.1 Description of Support Units.....	11
3.3 Test Mode Applicability and Tested Channel Detail.....	12
3.4 EUT Operating Conditions.....	25
3.5 General Description of Applied Standards and References.....	25
4 Test Types and Results	26
4.1 Output Power Measurement.....	26
4.1.1 Limits of Output Power Measurement.....	26
4.1.2 Test Procedures.....	26
4.1.3 Test Setup.....	26
4.1.4 Test Results.....	27
4.2 Modulation Characteristics Measurement.....	47
4.2.1 Limits of Modulation Characteristics.....	47
4.2.2 Test Procedure.....	47
4.2.3 Test Setup.....	47
4.2.4 Test Results.....	48
4.3 Frequency Stability Measurement.....	51
4.3.1 Limits of Frequency Stability Measurement.....	51
4.3.2 Test Procedure.....	51
4.3.3 Test Setup.....	51
4.3.4 Test Results.....	52
4.4 Occupied Bandwidth Measurement.....	70
4.4.1 Limits of Occupied Bandwidth Measurement.....	70
4.4.2 Test Procedure.....	70
4.4.3 Test Setup.....	70
4.4.4 Test Result.....	71
4.5 Band Edge / Out-of-Band Emissions Measurement.....	87
4.5.1 Limits of Band Edge / Out-of-Band Emissions Measurement.....	87
4.5.2 Test Setup.....	87
4.5.3 Test Procedures.....	87
4.5.4 Test Results.....	88
4.6 Peak to Average Ratio.....	106
4.6.1 Limits of Peak to Average Ratio Measurement.....	106
4.6.2 Test Setup.....	106
4.6.3 Test Procedures.....	106
4.6.4 Test Results.....	107
4.7 Conducted Spurious Emissions.....	115
4.7.1 Limits of Conducted Spurious Emissions Measurement.....	115
4.7.2 Test Setup.....	115
4.7.3 Test Procedure.....	115
4.7.4 Test Results.....	116
4.8 Radiated Emission Measurement.....	134
4.8.1 Limits of Radiated Emission Measurement.....	134
4.8.2 Test Procedure.....	134
4.8.3 Deviation from Test Standard.....	134
4.8.4 Test Setup.....	135

4.8.5 Test Results	136
5 Pictures of Test Arrangements.....	158
Appendix – Information of the Testing Laboratories	159

Release Control Record

Issue No.	Description	Date Issued
RFBCKT-WTW-P21031102-9	Original release	May 25, 2021

1 Certificate of Conformity

Product: 5G Hotspot

Brand: T-Mobile

Test Model: QTAD53

Sample Status: Engineering sample

Applicant: QUANTA COMPUTER INC

Test Date: Apr. 28 ~ May 25, 2021

Standards: FCC Part 27, Subpart C, L, M, N

The above equipment has been tested by **Bureau Veritas Consumer Products Services (H.K.) Ltd., Taoyuan Branch**, and found compliance with the requirement of the above standards. The test record, data evaluation & Equipment Under Test (EUT) configurations represented herein are true and accurate accounts of the measurements of the sample's RF characteristics under the conditions specified in this report.

Prepared by : Celine Chou , **Date:** May 25, 2021
Celine Chou / Senior Specialist

Approved by : Bruce Chen , **Date:** May 25, 2021
Bruce Chen / Senior Project Engineer

2 Summary of Test Results

Applied Standard: FCC Part 27 & Part 2					
FCC Clause			Test Item	Result	Remarks
n41	n66	n71			
2.1046 27.50 (h)(2)	2.1046 27.50 (d)(4)	2.1046 27.50 (c)	Equivalent Isotropically Radiated Power / Equivalent Radiated Power	Pass	Meet the requirement of limit.
2.1047	2.1047	2.1047	Modulation Characteristics	Pass	Meet the requirement of limit.
----	27.50 (d)(5)	----	Peak To Average Ratio	Pass	Meet the requirement of limit.
2.1055 27.54	2.1055 27.54	2.1055 27.54	Frequency Stability Stay with the authorized bands of operation	Pass	Meet the requirement of limit.
2.1049	2.1049	2.1049	Occupied Bandwidth	Pass	Meet the requirement of limit.
2.1051 27.53 (m)(4)(6)	2.1051 27.53 (h)	2.1051 27.53 (g)	Band Edge / Out of Band Emissions Measurements	Pass	Meet the requirement of limit.
2.1051 27.53 (m)(4)(6)	2.1051 27.53 (h)	2.1051 27.53 (g)	Conducted Spurious Emissions	Pass	Meet the requirement of limit.
2.1053 27.53 (m)(4)(6)	2.1053 27.53 (h)	2.1053 27.53 (g)	Radiated Spurious Emissions	Pass	Meet the requirement of limit. Minimum passing margin is -20.05dB at 5092.02MHz.

Note: Determining compliance based on the results of the compliance measurement, not taking into account measurement instrumentation uncertainty.

2.1 Measurement Uncertainty

Where relevant, the following measurement uncertainty levels have been estimated for tests performed on the EUT as specified in CISPR 16-4-2:

Measurement	Frequency	Expanded Uncertainty (k=2) (\pm)
Radiated Emissions up to 1 GHz	9kHz ~ 30MHz	3.04 dB
	30MHz ~ 200MHz	3.86 dB
	200MHz ~ 1000MHz	3.87 dB
Radiated Emissions above 1 GHz	1GHz ~ 18GHz	2.29 dB
	18GHz ~ 40GHz	2.29 dB

2.2 Test Site and Instruments

Description & Manufacturer	Model No.	Serial No.	Cal. Date	Cal. Due
Test Receiver ROHDE & SCHWARZ	ESR3	102579	Jul. 07, 2020	Jul. 06, 2021
Spectrum Analyzer ROHDE & SCHWARZ	FSP40	100269	Jun. 09, 2020	Jun. 08, 2021
MXG Vector signal generator Agilent	N5182B	MY53050430	Nov. 25, 2020	Nov. 24, 2021
5G Wireless Test Platforms Keysight	E7515B	MY60102114	May 28, 2020	May 27, 2021
BILOG Antenna SCHWARZBECK	VULB9168	9168-171	Nov. 04, 2020	Nov. 03, 2021
HORN Antenna SCHWARZBECK	9120D	209	Nov. 22, 2020	Nov. 21, 2021
HORN Antenna SCHWARZBECK	BBHA 9170	BBHA9170241	Nov. 22, 2020	Nov. 21, 2021
Loop Antenna TESEQ	HLA 6121	45745	Jul. 06, 2020	Jul. 05, 2021
Preamplifier Agilent (Below 1GHz)	8447D	2944A10738	Aug. 16, 2020	Aug. 15, 2021
Preamplifier Agilent (Above 1GHz)	8449B	3008A02465	Mar. 22, 2021	Mar. 21, 2022
RF Coaxial Cable WOKEN With 5dB PAD	8D-FB	Cable-CH3-01	Aug. 16, 2020	Aug. 15, 2021
RF signal cable HUBER+SUHNER	SUCOFLEX 104	Cable-CH3-03 (223653/4)	Aug. 16, 2020	Aug. 15, 2021
RF signal cable HUBER+SUHNER& EMCI	SUCOFLEX 104&EMC104-SM-S M-8000	Cable-CH3-03 (309224+170907)	Aug. 16, 2020	Aug. 15, 2021
Software BV ADT	ADT_Radiated_ V7.6.15.9.5	NA	NA	NA
Antenna Tower inn-co GmbH	MA 4000	013303	NA	NA
Antenna Tower Controller BV ADT	AT100	AT93021702	NA	NA
Turn Table BV ADT	TT100	TT93021702	NA	NA
Turn Table Controller BV ADT	SC100	SC93021702	NA	NA
Boresight Antenna Fixture	FBA-01	FBA-SIP01	NA	NA
Standard Temperature And Humidity Chamber GIANT FORCE	GTH-120-40-CP-AR	MAA1306-019	Sep. 10, 2020	Sep. 09, 2021
JFW 20dB attenuation	50HF-020-SMA	NA	NA	NA
True RMS Clamp Meter Fluke	325	31130711WS	Jun 06, 2020	Jun 05, 2021
DC power supply Keysight	U8002A	MY56330015	NA	NA

Note: 1. The calibration interval of the above test instruments is 12 months and the calibrations are traceable to NML/ROC and NIST/USA.
2. The test was performed in HwaYa Chamber 3.

3 General Information

3.1 General Description of EUT

Product	5G Hotspot	
Brand	T-Mobile	
Test Model	QTAD53	
Sample Status	Engineering sample	
Power Supply Rating	5Vdc / 9Vdc / 12Vdc (Adapter) 3.85Vdc (Battery)	
Modulation Type	$\pi/2$ BPSK, QPSK, 16QAM, 64QAM, 256QAM	
Waveform Type	CP-OFDM, DFT-s-OFDM	
Operating Frequency	n41 (Channel Bandwidth 10MHz)	2501.01MHz ~ 2685.00MHz
	n41 (Channel Bandwidth 15MHz)	2503.50MHz ~ 2682.48MHz
	n41 (Channel Bandwidth 20MHz)	2506.02MHz ~ 2679.99MHz
	n41 (Channel Bandwidth 40MHz)	2516.01MHz ~ 2670.00MHz
	n41 (Channel Bandwidth 50MHz)	2521.02MHz ~ 2664.99MHz
	n41 (Channel Bandwidth 60MHz)	2526.00MHz ~ 2659.98MHz
	n41 (Channel Bandwidth 80MHz)	2536.02MHz ~ 2649.99MHz
	n41 (Channel Bandwidth 90MHz)	2541.00MHz ~ 2644.98MHz
	n41 (Channel Bandwidth 100MHz)	2546.01MHz ~ 2640.00MHz
	n66 (Channel Bandwidth 5MHz)	1712.5MHz ~ 1777.5MHz
	n66 (Channel Bandwidth 10MHz)	1715.0MHz ~ 1775.0MHz
	n66 (Channel Bandwidth 15MHz)	1717.5MHz ~ 1772.5MHz
	n66 (Channel Bandwidth 20MHz)	1720.0MHz ~ 1770.0MHz
	n66 (Channel Bandwidth 40MHz)	1730.0MHz ~ 1760.0MHz
	n71 (Channel Bandwidth 5MHz)	665.5MHz ~ 695.5MHz
	n71 (Channel Bandwidth 10MHz)	668.0MHz ~ 693.0MHz
	n71 (Channel Bandwidth 15MHz)	670.5MHz ~ 690.5MHz
n71 (Channel Bandwidth 20MHz)	673.0MHz ~ 688.0MHz	

		$\pi/2$ BPSK	QPSK	16QAM	64QAM	256QAM	
		Max. EIRP Power	n41 (Channel Bandwidth 10MHz)	558.470mW (27.47dBm)	566.239mW (27.53dBm)	240.436mW (23.81dBm)	210.863mW (23.24dBm)
	n41 (Channel Bandwidth 15MHz)	561.048mW (27.49dBm)	568.853mW (27.55dBm)	241.546mW (23.83dBm)	211.836mW (23.26dBm)	168.655mW (22.27dBm)	
	n41 (Channel Bandwidth 20MHz)	564.937mW (27.52dBm)	572.796mW (27.58dBm)	243.220mW (23.86dBm)	213.304mW (23.29dBm)	169.824mW (22.30dBm)	
	n41 (Channel Bandwidth 40MHz)	571.479mW (27.57dBm)	579.429mW (27.63dBm)	246.037mW (23.91dBm)	215.774mW (23.34dBm)	171.791mW (22.35dBm)	
	n41 (Channel Bandwidth 50MHz)	574.116mW (27.59dBm)	582.103mW (27.65dBm)	247.172mW (23.93dBm)	216.770mW (23.36dBm)	172.584mW (22.37dBm)	
	n41 (Channel Bandwidth 60MHz)	576.766mW (27.61dBm)	584.790mW (27.67dBm)	248.313mW (23.95dBm)	217.771mW (23.38dBm)	173.380mW (22.39dBm)	
	n41 (Channel Bandwidth 80MHz)	583.445mW (27.66dBm)	591.562mW (27.72dBm)	251.189mW (24.00dBm)	220.293mW (23.43dBm)	175.388mW (22.44dBm)	
	n41 (Channel Bandwidth 90MHz)	588.844mW (27.70dBm)	597.035mW (27.76dBm)	253.513mW (24.04dBm)	222.331mW (23.47dBm)	177.011mW (22.48dBm)	
	n41 (Channel Bandwidth 100MHz)	592.925mW (27.73dBm)	601.174mW (27.79dBm)	255.270mW (24.07dBm)	223.872mW (23.50dBm)	178.238mW (22.51dBm)	
	n66 (Channel Bandwidth 5MHz)	442.588mW (26.46dBm)	452.898mW (26.56dBm)	327.341mW (25.15dBm)	308.319mW (24.89dBm)	190.985mW (22.81dBm)	
	n66 (Channel Bandwidth 10MHz)	444.631mW (26.48dBm)	454.988mW (26.58dBm)	328.852mW (25.17dBm)	309.742mW (24.91dBm)	191.867mW (22.83dBm)	
	n66 (Channel Bandwidth 15MHz)	448.745mW (26.52dBm)	459.198mW (26.62dBm)	331.894mW (25.21dBm)	312.608mW (24.95dBm)	193.642mW (22.87dBm)	
	n66 (Channel Bandwidth 20MHz)	451.856mW (26.55dBm)	462.381mW (26.65dBm)	334.195mW (25.24dBm)	314.775mW (24.98dBm)	194.984mW (22.90dBm)	
	n66 (Channel Bandwidth 40MHz)	460.257mW (26.63dBm)	470.977mW (26.73dBm)	340.408mW (25.32dBm)	320.627mW (25.06dBm)	198.609mW (22.98dBm)	
Max. ERP Power		$\pi/2$ BPSK	QPSK	16QAM	64QAM	256QAM	
		n71 (Channel Bandwidth 5MHz)	182.390mW (22.61dBm)	185.353mW (22.68dBm)	143.219mW (21.56dBm)	90.782mW (19.58dBm)	65.766mW (18.18dBm)
		n71 (Channel Bandwidth 10MHz)	185.780mW (22.69dBm)	187.068mW (22.72dBm)	143.880mW (21.58dBm)	91.411mW (19.61dBm)	64.863mW (18.12dBm)
		n71 (Channel Bandwidth 15MHz)	185.780mW (22.69dBm)	187.068mW (22.72dBm)	142.561mW (21.54dBm)	92.683mW (19.67dBm)	64.714mW (18.11dBm)
	n71 (Channel Bandwidth 20MHz)	187.068mW (22.72dBm)	189.671mW (22.78dBm)	144.544mW (21.60dBm)	92.897mW (19.68dBm)	65.766mW (18.18dBm)	

Emission Designator		$\pi/2$ BPSK	QPSK	16QAM	64QAM	256QAM
	n41 (Channel Bandwidth 10MHz)	8M56G7D	8M56G7D	8M56D7W	8M57D7W	8M56D7W
	n41 (Channel Bandwidth 15MHz)	13M5G7D	13M5G7D	13M6D7W	13M5D7W	13M6D7W
	n41 (Channel Bandwidth 20MHz)	18M3G7D	18M3G7D	18M3D7W	18M3D7W	18M3D7W
	n41 (Channel Bandwidth 40MHz)	37M8G7D	37M8G7D	37M8D7W	37M8D7W	37M8D7W
	n41 (Channel Bandwidth 50MHz)	47M4G7D	47M4G7D	47M4D7W	47M4D7W	47M4D7W
	n41 (Channel Bandwidth 60MHz)	57M7G7D	57M7G7D	57M7D7W	57M7D7W	57M7D7W
	n41 (Channel Bandwidth 80MHz)	77M4G7D	77M3G7D	77M3D7W	77M3D7W	77M3D7W
	n41 (Channel Bandwidth 90MHz)	87M3G7D	87M3G7D	87M3D7W	87M3D7W	87M3D7W
	n41 (Channel Bandwidth 100MHz)	97M2G7D	97M3G7D	97M3D7W	97M2D7W	97M2D7W
	n66 (Channel Bandwidth 5MHz)	4M46G7D	4M46G7D	4M46D7W	4M46D7W	4M46D7W
	n66 (Channel Bandwidth 10MHz)	9M28G7D	9M27G7D	9M28D7W	9M27D7W	9M26D7W
	n66 (Channel Bandwidth 15MHz)	14M1G7D	14M1G7D	14M1D7W	14M1D7W	14M1D7W
	n66 (Channel Bandwidth 20MHz)	18M9G7D	18M9G7D	18M9D7W	18M9D7W	18M9D7W
	n66 (Channel Bandwidth 40MHz)	38M6G7D	38M6G7D	38M6D7W	38M6D7W	38M6D7W
	n71 (Channel Bandwidth 5MHz)	4M46G7D	4M46G7D	4M46D7W	4M46D7W	4M46D7W
	n71 (Channel Bandwidth 10MHz)	9M27G7D	9M27G7D	9M28D7W	9M27D7W	9M26D7W
n71 (Channel Bandwidth 15MHz)	14M1G7D	14M1G7D	14M1D7W	14M1D7W	14M1D7W	
n71 (Channel Bandwidth 20MHz)	18M9G7D	18M9G7D	18M9D7W	18M9D7W	18M9D7W	
Antenna Type	Refer to Note as below					
Antenna Connector	Refer to Note as below					
Accessory Device	Refer to Note as below					
Cable Supplied	Refer to Note as below					

Note:

1. The EUT contains following accessory devices.

Product	Brand	Model	Description
Adapter 1	TEN PAO INTERNATIONAL LTD.	S018BYU1200150	I/P: 100-240Vac, 50/60Hz, 600mA O/P: 5Vdc/9Vdc/12Vdc=3A/2A/1.5A
Adapter 2	Aohai Technology Co., Ltd	A138A-120150U-US2	I/P: 100-240V~50/60Hz, 0.5A O/P: 5Vdc, 2.5A/9Vdc, 2A/12Vdc, 1.5A
USB Cable	Electronics Taiwan Ltd.	DDEMU110079	0.95m shielded USB cable without core
Battery	VEKEN	141033	3.85Vdc, 6240mAh, 24.02Wh

2. There are two sources for EUT's main board and memory. Only the supplier is different and the rest of the specifications are the same.

Sample	Item	Brand	Model
A	PCB - Main	Unimicron Technology Corporation.	12VPL4024C for MODEM board, 06VPL4028C for Main board
	Memory - Main	Nanya Technology Corporation	NM4888KSPAXAI-3E
B	PCB -Second	AKM Meadville	HI12C124A for MODEM board, HI06T221A for Main board
	Memory - Second	Jeju Semiconductor Corp.	JSFDDQ5QHAFGD-405

* After pre-tested, sample A was the worse and chosen for final test.

3. The following antennas were provided to the EUT.

5G FR1 Band						
Ant. No.	Type	Connector	Gain (dBi)			
			n25	n41	n66	n71
0	PIFA	MUR	1.23871	-	3.16163	0.426023
1	PIFA	IPEX	-	-	-	-
2	PIFA	IPEX	-	0.854078	-	-
3	PIFA	MUR	-	-	-	-
4	PIFA	IPEX	-	-0.283214	-	-

* The above Antenna information is declared by manufacturer and for more detailed features description, please refer to the manufacturer's specifications, the laboratory shall not be held responsible.

* The Ant. No. 2 and Ant. No. 4 output power were evaluated for the n41 frequency band, and it was found that the worst power was in the Ant. No. 2. Therefore chosen for the final test and record in the test report.

*Evaluated the output power of SCS 15kHz and SCS 30kHz on the n41 frequency band, and found that the worst power is in SCS 30kHz. Therefore, the final test is selected and recorded in the test report.

3.2 Configuration of System under Test

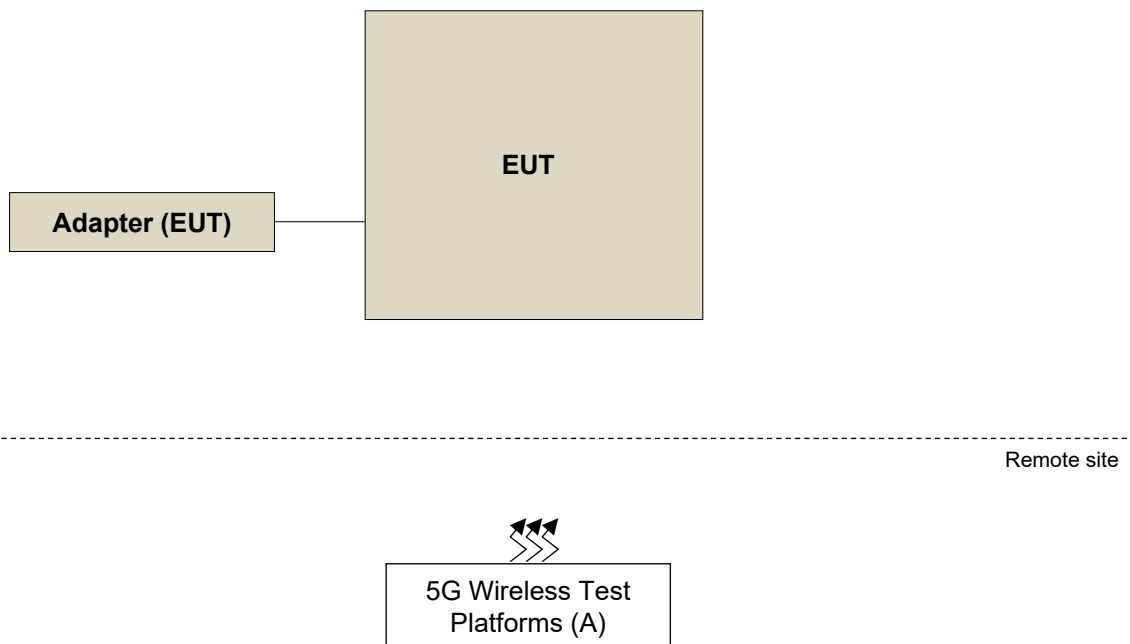

3.2.1 Description of Support Units

The EUT has been tested as an independent unit together with other necessary accessories or support units. The following support units or accessories were used to form a representative test configuration during the tests.

ID	Product	Brand	Model No.	Serial No.	FCC ID	Remarks
A.	5G Wireless Test Platforms	Keysight	E7515B	MY58300759	NA	-

Note:

1. All power cords of the above support units are non-shielded (1.8m).
2. Item A acted as a communication partner to transfer data.

3.3 Test Mode Applicability and Tested Channel Detail

Pre-Scan has been conducted to determine the worst-case mode from all possible combinations between available modulations, data rates, XYZ axis and antenna ports. The worst case was found when positioned as the table below. Following channel(s) was (were) selected for the final test as listed below:

Band	Radiated Emission
n41	X-plane
n66	X-plane
n71	X-plane

n41

EUT Configure Mode	Test item	Available channel	Tested channel	Channel Bandwidth	Modulation	Mode
-	EIRP	500202 to 537000	500202 (2501.01MHz), 518598 (2592.99MHz), 537000 (2685.00MHz)	10MHz	$\pi/2$ BPSK / QPSK / 16QAM / 64QAM / 256QAM	1 RB / 1 RB Offset 1 RB / 11 RB Offset 1 RB / 22 RB Offset 12 RB / 0 RB Offset 12 RB / 6 RB Offset 12 RB / 12 RB Offset 24 RB / 0 RB Offset
		500700 to 536496	500700 (2503.50MHz), 518598 (2592.99MHz), 536496 (2682.48MHz)	15MHz	$\pi/2$ BPSK / QPSK / 16QAM / 64QAM / 256QAM	1 RB / 1 RB Offset 1 RB / 19 RB Offset 1 RB / 36 RB Offset 18 RB / 0 RB Offset 18 RB / 10 RB Offset 18 RB / 20 RB Offset 36 RB / 0 RB Offset
		501204 to 535998	501204 (2506.02MHz), 518598 (2592.99MHz), 535998 (2679.99MHz)	20MHz	$\pi/2$ BPSK / QPSK / 16QAM / 64QAM / 256QAM	1 RB / 1 RB Offset 1 RB / 26 RB Offset 1 RB / 49 RB Offset 25 RB / 0 RB Offset 25 RB / 13 RB Offset 25 RB / 26 RB Offset 50 RB / 0 RB Offset
		503202 to 534000	503202 (2516.01MHz), 518598 (2592.99MHz), 534000 (2670.00MHz)	40MHz	$\pi/2$ BPSK / QPSK / 16QAM / 64QAM / 256QAM	1 RB / 1 RB Offset 1 RB / 53 RB Offset 1 RB / 104 RB Offset 50 RB / 0 RB Offset 50 RB / 28 RB Offset 50 RB / 56 RB Offset 100 RB / 0 RB Offset
		504204 to 532998	504204 (2521.02MHz), 518598 (2592.99MHz), 532998 (2664.99MHz)	50MHz	$\pi/2$ BPSK / QPSK / 16QAM / 64QAM / 256QAM	1 RB / 1 RB Offset 1 RB / 67 RB Offset 1 RB / 131 RB Offset 64 RB / 0 RB Offset 64 RB / 35 RB Offset 64 RB / 69 RB Offset 128 RB / 0 RB Offset

EUT Configure Mode	Test item	Available channel	Tested channel	Channel Bandwidth	Modulation	Mode
-	EIRP	505200 to 531996	505200 (2526.00MHz), 518598 (2592.99MHz), 531996 (2659.98MHz)	60MHz	$\pi/2$ BPSK / QPSK / 16QAM / 64QAM / 256QAM	1 RB / 1 RB Offset 1 RB / 81 RB Offset 1 RB / 160 RB Offset 81 RB / 0 RB Offset 81 RB / 41 RB Offset 81 RB / 81 RB Offset 162 RB / 0 RB Offset
		507204 to 529998	507204 (2536.02MHz), 518598 (2592.99MHz), 529998 (2649.99MHz)	80MHz	$\pi/2$ BPSK / QPSK / 16QAM / 64QAM / 256QAM	1 RB / 1 RB Offset 1 RB / 109 RB Offset 1 RB / 215 RB Offset 108 RB / 0 RB Offset 108 RB / 55 RB Offset 108 RB / 109 RB Offset 216 RB / 0 RB Offset
		508200 to 528996	508200 (2541.00MHz), 518598 (2592.99MHz), 528996 (2644.98MHz)	90MHz	$\pi/2$ BPSK / QPSK / 16QAM / 64QAM / 256QAM	1 RB / 1 RB Offset 1 RB / 123 RB Offset 1 RB / 243 RB Offset 120 RB / 0 RB Offset 120 RB / 63 RB Offset 120 RB / 125 RB Offset 243 RB / 0 RB Offset
-	EIRP	509202 to 528000	509202 (2546.01MHz), 518598 (2592.99MHz), 528000 (2640.00MHz)	100MHz	$\pi/2$ BPSK / QPSK / 16QAM / 64QAM / 256QAM	1 RB / 1 RB Offset 1 RB / 137 RB Offset 1 RB / 271 RB Offset 135 RB / 0 RB Offset 135 RB / 69 RB Offset 135 RB / 138 RB Offset 270 RB / 0 RB Offset
-	Modulation Characteristics	509202 to 528000	518598 (2592.99MHz)	100MHz	$\pi/2$ BPSK / QPSK / 16QAM / 64QAM / 256QAM	273 RB / 0 RB Offset
-	Frequency Stability	500202 to 537000	500202 (2501.01MHz), 537000 (2685.00MHz)	10MHz	QPSK	24 RB / 0 RB Offset
		500700 to 536496	500700 (2503.50MHz), 536496 (2682.48MHz)	15MHz	QPSK	38 RB / 0 RB Offset
		501204 to 535998	501204 (2506.02MHz), 535998 (2679.99MHz)	20MHz	QPSK	51 RB / 0 RB Offset
		503202 to 534000	503202 (2516.01MHz), 534000 (2670.00MHz)	40MHz	QPSK	106 RB / 0 RB Offset
		504204 to 532998	504204 (2521.02MHz), 532998 (2664.99MHz)	50MHz	QPSK	133 RB / 0 RB Offset
		505200 to 531996	505200 (2526.00MHz), 531996 (2659.98MHz)	60MHz	QPSK	162 RB / 0 RB Offset
		507204 to 529998	507204 (2536.02MHz), 529998 (2649.99MHz)	80MHz	QPSK	217 RB / 0 RB Offset
		508200 to 528996	508200 (2541.00MHz), 528996 (2644.98MHz)	90MHz	QPSK	245 RB / 0 RB Offset
		509202 to 528000	509202 (2546.01MHz), 528000 (2640.00MHz)	100MHz	QPSK	273 RB / 0 RB Offset

EUT Configure Mode	Test item	Available channel	Tested channel	Channel Bandwidth	Modulation	Mode
-	Emission Bandwidth	500202 to 537000	500202 (2501.01MHz), 518598 (2592.99MHz), 537000 (2685.00MHz)	10MHz	$\pi/2$ BPSK / QPSK / 16QAM / 64QAM / 256QAM	24 RB / 0 RB Offset
		500700 to 536496	500700 (2503.50MHz), 518598 (2592.99MHz), 536496 (2682.48MHz)	15MHz	$\pi/2$ BPSK / QPSK / 16QAM / 64QAM / 256QAM	38 RB / 0 RB Offset
		501204 to 535998	501204 (2506.02MHz), 518598 (2592.99MHz), 535998 (2679.99MHz)	20MHz	$\pi/2$ BPSK / QPSK / 16QAM / 64QAM / 256QAM	51 RB / 0 RB Offset
		503202 to 534000	503202 (2516.01MHz), 518598 (2592.99MHz), 534000 (2670.00MHz)	40MHz	$\pi/2$ BPSK / QPSK / 16QAM / 64QAM / 256QAM	106 RB / 0 RB Offset
		504204 to 532998	504204 (2521.02MHz), 518598 (2592.99MHz), 532998 (2664.99MHz)	50MHz	$\pi/2$ BPSK / QPSK / 16QAM / 64QAM / 256QAM	133 RB / 0 RB Offset
		505200 to 531996	505200 (2526.00MHz), 518598 (2592.99MHz), 531996 (2659.98MHz)	60MHz	$\pi/2$ BPSK / QPSK / 16QAM / 64QAM / 256QAM	162 RB / 0 RB Offset
		507204 to 529998	507204 (2536.02MHz), 518598 (2592.99MHz), 529998 (2649.99MHz)	80MHz	$\pi/2$ BPSK / QPSK / 16QAM / 64QAM / 256QAM	217 RB / 0 RB Offset
		508200 to 528996	508200 (2541.00MHz), 518598 (2592.99MHz), 528996 (2644.98MHz)	90MHz	$\pi/2$ BPSK / QPSK / 16QAM / 64QAM / 256QAM	245 RB / 0 RB Offset
		509202 to 528000	509202 (2546.01MHz), 518598 (2592.99MHz), 528000 (2640.00MHz)	100MHz	$\pi/2$ BPSK / QPSK / 16QAM / 64QAM / 256QAM	273 RB / 0 RB Offset

EUT Configure Mode	Test item	Available channel	Tested channel	Channel Bandwidth	Modulation	Mode
-	Out-of-Band Emissions	500202 to 537000	500202 (2501.01MHz), 537000 (2685.00MHz)	10MHz	QPSK	1 RB / 0 RB Offset 1 RB / 23 RB Offset 24 RB / 0 RB Offset
		500700 to 536496	500700 (2503.50MHz), 536496 (2682.48MHz)	15MHz	QPSK	1 RB / 0 RB Offset 1 RB / 37 RB Offset 38 RB / 0 RB Offset
		501204 to 535998	501204 (2506.02MHz), 535998 (2679.99MHz)	20MHz	QPSK	1 RB / 0 RB Offset 1 RB / 50 RB Offset 51 RB / 0 RB Offset
		503202 to 534000	503202 (2516.01MHz), 534000 (2670.00MHz)	40MHz	QPSK	1 RB / 0 RB Offset 1 RB / 105 RB Offset 106 RB / 0 RB Offset
		504204 to 532998	504204 (2521.02MHz), 532998 (2664.99MHz)	50MHz	QPSK	1 RB / 0 RB Offset 1 RB / 132 RB Offset 133 RB / 0 RB Offset
		505200 to 531996	505200 (2526.00MHz), 531996 (2659.98MHz)	60MHz	QPSK	1 RB / 0 RB Offset 1 RB / 161 RB Offset 162 RB / 0 RB Offset
		507204 to 529998	507204 (2536.02MHz), 529998 (2649.99MHz)	80MHz	QPSK	1 RB / 0 RB Offset 1 RB / 216 RB Offset 217 RB / 0 RB Offset
		508200 to 528996	508200 (2541.00MHz), 528996 (2644.98MHz)	90MHz	QPSK	1 RB / 0 RB Offset 1 RB / 244 RB Offset 245 RB / 0 RB Offset
		509202 to 528000	509202 (2546.01MHz), 528000 (2640.00MHz)	100MHz	QPSK	1 RB / 0 RB Offset 1 RB / 272 RB Offset 273 RB / 0 RB Offset

EUT Configure Mode	Test item	Available channel	Tested channel	Channel Bandwidth	Modulation	Mode
-	Peak to Average Ratio	500202 to 537000	500202 (2501.01MHz), 518598 (2592.99MHz), 537000 (2685.00MHz)	10MHz	$\pi/2$ BPSK / QPSK / 16QAM / 64QAM / 256QAM	1 RB / 1 RB Offset
		500700 to 536496	500700 (2503.50MHz), 518598 (2592.99MHz), 536496 (2682.48MHz)	15MHz	$\pi/2$ BPSK / QPSK / 16QAM / 64QAM / 256QAM	1 RB / 1 RB Offset
		501204 to 535998	501204 (2506.02MHz), 518598 (2592.99MHz), 535998 (2679.99MHz)	20MHz	$\pi/2$ BPSK / QPSK / 16QAM / 64QAM / 256QAM	1 RB / 1 RB Offset
		503202 to 534000	503202 (2516.01MHz), 518598 (2592.99MHz), 534000 (2670.00MHz)	40MHz	$\pi/2$ BPSK / QPSK / 16QAM / 64QAM / 256QAM	1 RB / 1 RB Offset
		504204 to 532998	504204 (2521.02MHz), 518598 (2592.99MHz), 532998 (2664.99MHz)	50MHz	$\pi/2$ BPSK / QPSK / 16QAM / 64QAM / 256QAM	1 RB / 1 RB Offset
		505200 to 531996	505200 (2526.00MHz), 518598 (2592.99MHz), 531996 (2659.98MHz)	60MHz	$\pi/2$ BPSK / QPSK / 16QAM / 64QAM / 256QAM	1 RB / 1 RB Offset
		507204 to 529998	507204 (2536.02MHz), 518598 (2592.99MHz), 529998 (2649.99MHz)	80MHz	$\pi/2$ BPSK / QPSK / 16QAM / 64QAM / 256QAM	1 RB / 1 RB Offset
		508200 to 528996	508200 (2541.00MHz), 518598 (2592.99MHz), 528996 (2644.98MHz)	90MHz	$\pi/2$ BPSK / QPSK / 16QAM / 64QAM / 256QAM	1 RB / 1 RB Offset
		509202 to 528000	509202 (2546.01MHz), 518598 (2592.99MHz), 528000 (2640.00MHz)	100MHz	$\pi/2$ BPSK / QPSK / 16QAM / 64QAM / 256QAM	1 RB / 1 RB Offset

EUT Configure Mode	Test item	Available channel	Tested channel	Channel Bandwidth	Modulation	Mode
-	Conducted Emission	500202 to 537000	500202 (2501.01MHz), 518598 (2592.99MHz), 537000 (2685.00MHz)	10MHz	QPSK	1 RB / 1 RB Offset
		500700 to 536496	500700 (2503.50MHz), 518598 (2592.99MHz), 536496 (2682.48MHz)	15MHz	QPSK	1 RB / 1 RB Offset
		501204 to 535998	501204 (2506.02MHz), 518598 (2592.99MHz), 535998 (2679.99MHz)	20MHz	QPSK	1 RB / 1 RB Offset
		503202 to 534000	503202 (2516.01MHz), 518598 (2592.99MHz), 534000 (2670.00MHz)	40MHz	QPSK	1 RB / 1 RB Offset
		504204 to 532998	504204 (2521.02MHz), 518598 (2592.99MHz), 532998 (2664.99MHz)	50MHz	QPSK	1 RB / 1 RB Offset
		505200 to 531996	505200 (2526.00MHz), 518598 (2592.99MHz), 531996 (2659.98MHz)	60MHz	QPSK	1 RB / 1 RB Offset
		507204 to 529998	507204 (2536.02MHz), 518598 (2592.99MHz), 529998 (2649.99MHz)	80MHz	QPSK	1 RB / 1 RB Offset
		508200 to 528996	508200 (2541.00MHz), 518598 (2592.99MHz), 528996 (2644.98MHz)	90MHz	QPSK	1 RB / 1 RB Offset
		509202 to 528000	509202 (2546.01MHz), 518598 (2592.99MHz), 528000 (2640.00MHz)	100MHz	QPSK	1 RB / 1 RB Offset
-	Radiated Emission Below 1GHz	509202 to 528000	509202 (2546.01MHz)	100MHz	QPSK	1 RB / 1 RB Offset
-	Radiated Emission Above 1GHz	500202 to 537000	500202 (2501.01MHz), 518598 (2592.99MHz), 537000 (2685.00MHz)	10MHz	QPSK	1 RB / 1 RB Offset
		504204 to 532998	504204 (2521.02MHz), 518598 (2592.99MHz), 532998 (2664.99MHz)	50MHz	QPSK	1 RB / 1 RB Offset
		509202 to 528000	509202 (2546.01MHz), 518598 (2592.99MHz), 528000 (2640.00MHz)	100MHz	QPSK	1 RB / 1 RB Offset

Note:

1. For radiated emission below 1GHz, select the worst radiated emission channel (above 1GHz) for final testing.
2. For radiated emission above 1GHz, according to 3GPP 38.521-1 Section 6.5.3.1.4, choose the lowest, mid and highest channel bandwidth for final test.
3. Only output power, modulation characteristics, occupied bandwidth and Peak to average ratio items had been tested under $\pi/2$ BPSK, QPSK, 16QAM, 64QAM and 256QAM modes, the other test items were performed under worse mode according to the maximum output power.

n66

EUT Configure Mode	Test item	Available channel	Tested channel	Channel Bandwidth	Modulation	Mode
-	EIRP	342500 to 355500	342500 (1712.5MHz), 349000 (1745.0MHz), 355500 (1777.5MHz)	5MHz	$\pi/2$ BPSK / QPSK / 16QAM / 64QAM / 256QAM	1 RB / 1 RB Offset 1 RB / 13 RB Offset 1 RB / 23 RB Offset 12 RB / 0 RB Offset 12 RB / 7 RB Offset 12 RB / 13 RB Offset 25 RB / 0 RB Offset
		343000 to 355000	343000 (1715.0MHz), 349000 (1745.0MHz), 355000 (1775.0MHz)	10MHz	$\pi/2$ BPSK / QPSK / 16QAM / 64QAM / 256QAM	1 RB / 1 RB Offset 1 RB / 26 RB Offset 1 RB / 50 RB Offset 25 RB / 0 RB Offset 25 RB / 14 RB Offset 25 RB / 27 RB Offset 50 RB / 0 RB Offset
		343500 to 354500	343500 (1717.5MHz), 349000 (1745.0MHz), 354500 (1772.5MHz)	15MHz	$\pi/2$ BPSK / QPSK / 16QAM / 64QAM / 256QAM	1 RB / 1 RB Offset 1 RB / 40 RB Offset 1 RB / 77 RB Offset 36 RB / 0 RB Offset 36 RB / 22 RB Offset 36 RB / 43 RB Offset 75 RB / 0 RB Offset
		344000 to 354000	344000 (1720.0MHz), 349000 (1745.0MHz), 354000 (1770.0MHz)	20MHz	$\pi/2$ BPSK / QPSK / 16QAM / 64QAM / 256QAM	1 RB / 1 RB Offset 1 RB / 53 RB Offset 1 RB / 104 RB Offset 50RB / 0 RB Offset 50 RB / 28 RB Offset 50 RB / 56 RB Offset 100 RB / 0 RB Offset
		346000 to 352000	346000 (1730.0MHz), 349000 (1745.0MHz), 352000 (1760.0MHz)	40MHz	$\pi/2$ BPSK / QPSK / 16QAM / 64QAM / 256QAM	1 RB / 1 RB Offset 1 RB / 108 RB Offset 1 RB / 214 RB Offset 108RB / 0 RB Offset 108 RB / 54 RB Offset 108 RB / 108 RB Offset 216 RB / 0 RB Offset
-	Modulation characteristics	346000 to 352000	349000 (1745.0MHz)	40MHz	$\pi/2$ BPSK / QPSK / 16QAM / 64QAM / 256QAM	216 RB / 0 RB Offset
-	Frequency Stability	342500 to 355500	342500 (1712.5MHz), 355500 (1777.5MHz)	5MHz	QPSK	25 RB / 0 RB Offset
		343000 to 355000	343000 (1715.0MHz), 355000 (1775.0MHz)	10MHz	QPSK	52 RB / 0 RB Offset
		343500 to 354500	343500 (1717.5MHz), 354500 (1772.5MHz)	15MHz	QPSK	79 RB / 0 RB Offset
		344000 to 354000	344000 (1720.0MHz), 354000 (1770.0MHz)	20MHz	QPSK	106 RB / 0 RB Offset
		346000 to 352000	346000 (1730.0MHz), 352000 (1760.0MHz)	40MHz	QPSK	216 RB / 0 RB Offset

EUT Configure Mode	Test item	Available channel	Tested channel	Channel Bandwidth	Modulation	Mode
-	Occupied Bandwidth	342500 to 355500	342500 (1712.5MHz), 349000 (1745.0MHz), 355500 (1777.5MHz)	5MHz	$\pi/2$ BPSK / QPSK / 16QAM / 64QAM / 256QAM	25 RB / 0 RB Offset
		343000 to 355000	343000 (1715.0MHz), 349000 (1745.0MHz), 355000 (1775.0MHz)	10MHz	$\pi/2$ BPSK / QPSK / 16QAM / 64QAM / 256QAM	52 RB / 0 RB Offset
		343500 to 354500	343500 (1717.5MHz), 349000 (1745.0MHz), 354500 (1772.5MHz)	15MHz	$\pi/2$ BPSK / QPSK / 16QAM / 64QAM / 256QAM	79 RB / 0 RB Offset
		344000 to 354000	344000 (1720.0MHz), 349000 (1745.0MHz), 354000 (1770.0MHz)	20MHz	$\pi/2$ BPSK / QPSK / 16QAM / 64QAM / 256QAM	106 RB / 0 RB Offset
		346000 to 352000	346000 (1730.0MHz), 349000 (1745.0MHz), 352000 (1760.0MHz)	40MHz	$\pi/2$ BPSK / QPSK / 16QAM / 64QAM / 256QAM	216 RB / 0 RB Offset
-	Band Edge	342500 to 355500	342500 (1712.5MHz), 355500 (1777.5MHz)	5MHz	QPSK	1 RB / 0 RB Offset 1 RB / 24 RB Offset 25 RB / 0 RB Offset
		343000 to 355000	343000 (1715.0MHz), 355000 (1775.0MHz)	10MHz	QPSK	1 RB / 0 RB Offset 1 RB / 51 RB Offset 52 RB / 0 RB Offset
		343500 to 354500	343500 (1717.5MHz), 354500 (1772.5MHz)	15MHz	QPSK	1 RB / 0 RB Offset 1 RB / 78 RB Offset 79 RB / 0 RB Offset
		344000 to 354000	344000 (1720.0MHz), 354000 (1770.0MHz)	20MHz	QPSK	1 RB / 0 RB Offset 1 RB / 105 RB Offset 106 RB / 0 RB Offset
		346000 to 352000	346000 (1730.0MHz), 352000 (1760.0MHz)	40MHz	QPSK	1 RB / 0 RB Offset 1 RB / 215 RB Offset 216 RB / 0 RB Offset

EUT Configure Mode	Test item	Available channel	Tested channel	Channel Bandwidth	Modulation	Mode
-	Peak to Average Ratio	342500 to 355500	342500 (1712.5MHz), 349000 (1745.0MHz), 355500 (1777.5MHz)	5MHz	$\pi/2$ BPSK / QPSK / 16QAM / 64QAM / 256QAM	1 RB / 1 RB Offset
		343000 to 355000	343000 (1715.0MHz), 349000 (1745.0MHz), 355000 (1775.0MHz)	10MHz	$\pi/2$ BPSK / QPSK / 16QAM / 64QAM / 256QAM	1 RB / 1 RB Offset
		343500 to 354500	343500 (1717.5MHz), 349000 (1745.0MHz), 354500 (1772.5MHz)	15MHz	$\pi/2$ BPSK / QPSK / 16QAM / 64QAM / 256QAM	1 RB / 1 RB Offset
		344000 to 354000	344000 (1720.0MHz), 349000 (1745.0MHz), 354000 (1770.0MHz)	20MHz	$\pi/2$ BPSK / QPSK / 16QAM / 64QAM / 256QAM	1 RB / 1 RB Offset
		346000 to 352000	346000 (1730.0MHz), 349000 (1745.0MHz), 352000 (1760.0MHz)	40MHz	$\pi/2$ BPSK / QPSK / 16QAM / 64QAM / 256QAM	1 RB / 1 RB Offset
-	Conducted Emission	342500 to 355500	342500 (1712.5MHz), 349000 (1745.0MHz), 355500 (1777.5MHz)	5MHz	QPSK	1 RB / 1 RB Offset
		343000 to 355000	343000 (1715.0MHz), 349000 (1745.0MHz), 355000 (1775.0MHz)	10MHz	QPSK	1 RB / 1 RB Offset
		343500 to 354500	343500 (1717.5MHz), 349000 (1745.0MHz), 354500 (1772.5MHz)	15MHz	QPSK	1 RB / 1 RB Offset
		344000 to 354000	344000 (1720.0MHz), 349000 (1745.0MHz), 354000 (1770.0MHz)	20MHz	QPSK	1 RB / 1 RB Offset
		346000 to 352000	346000 (1730.0MHz), 349000 (1745.0MHz), 352000 (1760.0MHz)	40MHz	QPSK	1 RB / 1 RB Offset

EUT Configure Mode	Test item	Available channel	Tested channel	Channel Bandwidth	Modulation	Mode
-	Radiated Emission Below 1GHz	344000 to 354000	344000 (1720.0MHz)	20MHz	QPSK	1 RB / 1 RB Offset
-	Radiated Emission Above 1GHz	342500 to 355500	342500 (1712.5MHz), 349000 (1745.0MHz), 355500 (1777.5MHz)	5MHz	QPSK	1 RB / 1 RB Offset
		344000 to 354000	344000 (1720.0MHz), 349000 (1745.0MHz), 354000 (1770.0MHz)	20MHz	QPSK	1 RB / 1 RB Offset
		346000 to 352000	346000 (1730.0MHz), 349000 (1745.0MHz), 352000 (1760.0MHz)	40MHz	QPSK	1 RB / 1 RB Offset

Note:

1. For radiated emission below 1GHz, select the worst radiated emission channel (above 1GHz) for final testing.
2. For radiated emission above 1GHz, according to 3GPP 38.521-1 Section 6.5.3.1.4, choose the lowest, mid and highest channel bandwidth for final test.
3. Only output power, modulation characteristics, occupied bandwidth and Peak to average ratio items had been tested under $\pi/2$ BPSK, QPSK, 16QAM, 64QAM and 256QAM modes, the other test items were performed under worse mode according to the maximum output power.

n71

EUT Configure Mode	Test item	Available channel	Tested channel	Channel Bandwidth	Modulation	Mode
-	ERP	133100 to 139100	133100 (665.5MHz), 136100 (680.5MHz), 139100 (695.5MHz)	5MHz	$\pi/2$ BPSK / QPSK / 16QAM / 64QAM / 256QAM	1 RB / 1 RB Offset 1 RB / 13 RB Offset 1 RB / 23 RB Offset 12 RB / 0 RB Offset 12 RB / 7 RB Offset 12 RB / 13 RB Offset 25 RB / 0 RB Offset
		133600 to 138600	133600 (668.0MHz), 136100 (680.5MHz), 138600 (693.0MHz)	10MHz	$\pi/2$ BPSK / QPSK / 16QAM / 64QAM / 256QAM	1 RB / 1 RB Offset 1 RB / 26 RB Offset 1 RB / 50 RB Offset 25 RB / 0 RB Offset 25 RB / 14 RB Offset 25 RB / 27 RB Offset 50 RB / 0 RB Offset
		134100 to 138100	134100 (670.5MHz), 136100 (680.5MHz), 138100 (690.5MHz)	15MHz	$\pi/2$ BPSK / QPSK / 16QAM / 64QAM / 256QAM	1 RB / 1 RB Offset 1 RB / 40 RB Offset 1 RB / 77 RB Offset 36 RB / 0 RB Offset 36 RB / 22 RB Offset 36 RB / 43 RB Offset 75 RB / 0 RB Offset
		134600 to 137600	134600 (673.0MHz), 136100 (680.5MHz), 137600 (688.0MHz)	20MHz	$\pi/2$ BPSK / QPSK / 16QAM / 64QAM / 256QAM	1 RB / 1 RB Offset 1 RB / 53 RB Offset 1 RB / 104 RB Offset 50RB / 0 RB Offset 50 RB / 28 RB Offset 50 RB / 56 RB Offset 100 RB / 0 RB Offset
-	Modulation Characteristics	134600 to 137600	136100 (680.5MHz)	20MHz	$\pi/2$ BPSK / QPSK / 16QAM / 64QAM / 256QAM	106 RB / 0 RB Offset
-	Frequency Stability	133100 to 139100	133100 (665.5MHz), 139100 (695.5MHz)	5MHz	QPSK	25 RB / 0 RB Offset
		133600 to 138600	133600 (668.0MHz), 138600 (693.0MHz)	10MHz	QPSK	52 RB / 0 RB Offset
		134100 to 138100	134100 (670.5MHz), 138100 (690.5MHz)	15MHz	QPSK	79 RB / 0 RB Offset
		134600 to 137600	134600 (673.0MHz), 137600 (688.0MHz)	20MHz	QPSK	106 RB / 0 RB Offset

EUT Configure Mode	Test item	Available channel	Tested channel	Channel Bandwidth	Modulation	Mode
-	Emission Bandwidth	133100 to 139100	133100 (665.5MHz), 136100 (680.5MHz), 139100 (695.5MHz)	5MHz	$\pi/2$ BPSK / QPSK / 16QAM / 64QAM / 256QAM	25 RB / 0 RB Offset
		133600 to 138600	133600 (668.0MHz), 136100 (680.5MHz), 138600 (693.0MHz)	10MHz	$\pi/2$ BPSK / QPSK / 16QAM / 64QAM / 256QAM	52 RB / 0 RB Offset
		134100 to 138100	134100 (670.5MHz), 136100 (680.5MHz), 138100 (690.5MHz)	15MHz	$\pi/2$ BPSK / QPSK / 16QAM / 64QAM / 256QAM	79 RB / 0 RB Offset
		134600 to 137600	134600 (673.0MHz), 136100 (680.5MHz), 137600 (688.0MHz)	20MHz	$\pi/2$ BPSK / QPSK / 16QAM / 64QAM / 256QAM	106 RB / 0 RB Offset
-	Band Edge	133100 to 139100	133100 (665.5MHz), 139100 (695.5MHz)	5MHz	QPSK	1 RB / 0 RB Offset 1 RB / 24 RB Offset 25 RB / 0 RB Offset
		133600 to 138600	133600 (668.0MHz), 138600 (693.0MHz)	10MHz	QPSK	1 RB / 0 RB Offset 1 RB / 51 RB Offset 52 RB / 0 RB Offset
		134100 to 138100	134100 (670.5MHz), 138100 (690.5MHz)	15MHz	QPSK	1 RB / 0 RB Offset 1 RB / 78 RB Offset 79 RB / 0 RB Offset
		134600 to 137600	134600 (673.0MHz), 137600 (688.0MHz)	20MHz	QPSK	1 RB / 0 RB Offset 1 RB / 105 RB Offset 106 RB / 0 RB Offset
-	Peak to Average Ratio	133100 to 139100	133100 (665.5MHz), 136100 (680.5MHz), 139100 (695.5MHz)	5MHz	$\pi/2$ BPSK / QPSK / 16QAM / 64QAM / 256QAM	1 RB / 1 RB Offset
		133600 to 138600	133600 (668.0MHz), 136100 (680.5MHz), 138600 (693.0MHz)	10MHz	$\pi/2$ BPSK / QPSK / 16QAM / 64QAM / 256QAM	1 RB / 1 RB Offset
		134100 to 138100	134100 (670.5MHz), 136100 (680.5MHz), 138100 (690.5MHz)	15MHz	$\pi/2$ BPSK / QPSK / 16QAM / 64QAM / 256QAM	1 RB / 1 RB Offset
		134600 to 137600	134600 (673.0MHz), 136100 (680.5MHz), 137600 (688.0MHz)	20MHz	$\pi/2$ BPSK / QPSK / 16QAM / 64QAM / 256QAM	1 RB / 1 RB Offset

EUT Configure Mode	Test item	Available channel	Tested channel	Channel Bandwidth	Modulation	Mode
-	Conducted Emission	133100 to 139100	133100 (665.5MHz), 136100 (680.5MHz), 139100 (695.5MHz)	5MHz	QPSK	1 RB / 1 RB Offset
		133600 to 138600	133600 (668.0MHz), 136100 (680.5MHz), 138600 (693.0MHz)	10MHz	QPSK	1 RB / 1 RB Offset
		134100 to 138100	134100 (670.5MHz), 136100 (680.5MHz), 138100 (690.5MHz)	15MHz	QPSK	1 RB / 1 RB Offset
		134600 to 137600	134600 (673.0MHz), 136100 (680.5MHz), 137600 (688.0MHz)	20MHz	QPSK	1 RB / 1 RB Offset
-	Radiated Emission Below 1GHz	133100 to 139100	139100 (695.5MHz)	5MHz	QPSK	1 RB / 1 RB Offset
-	Radiated Emission Above 1GHz	133100 to 139100	133100 (665.5MHz), 136100 (680.5MHz), 139100 (695.5MHz)	5MHz	QPSK	1 RB / 1 RB Offset
		134600 to 137600	134600 (673.0MHz), 136100 (680.5MHz), 137600 (688.0MHz)	20MHz	QPSK	1 RB / 1 RB Offset

Note:

1. For radiated emission below 1GHz, select the worst radiated emission channel (above 1GHz) for final testing.
2. For radiated emission above 1GHz, according to 3GPP 38.521-1 Section 6.5.3.1.4, choose the lowest and highest channel bandwidth for final test.
3. Only output power, modulation characteristics, occupied bandwidth and Peak to average ratio items had been tested under $\pi/2$ BPSK, QPSK, 16QAM, 64QAM and 256QAM modes, the other test items were performed under worse mode according to the maximum output power.

Test Condition:

Test Item	Environmental Conditions	Input Power	Tested By
EIRP / ERP	25deg. C, 60%RH	120Vac, 60Hz	James Yang
Modulation Characteristics	25deg. C, 60%RH	120Vac, 60Hz	James Yang
Frequency Stability	25deg. C, 60%RH	3.85Vdc	James Yang
Occupied Bandwidth	25deg. C, 60%RH	120Vac, 60Hz	James Yang
Band Edge	25deg. C, 60%RH	120Vac, 60Hz	James Yang
Peak To Average Ratio	25deg. C, 60%RH	120Vac, 60Hz	James Yang
Conducted Emission	25deg. C, 60%RH	120Vac, 60Hz	James Yang
Radiated Emission	23deg. C, 67%RH 23deg. C, 66%RH	120Vac, 60Hz	Adair Peng Titan Hsu

3.4 EUT Operating Conditions

The EUT makes a call to the communication simulator. The communication simulator station system controlled a EUT to export maximum output power under transmission mode and specific channel frequency

3.5 General Description of Applied Standards and References

The EUT is a RF Product. According to the specifications of the manufacturer, it must comply with the requirements of the following standards and References:

Test Standard:

FCC 47 CFR Part 2

FCC 47 CFR Part 27

ANSI/TIA/EIA-603-E 2016

ANSI 63.26-2015

All test items have been performed and recorded as per the above standards.

References Test Guidance:

KDB 971168 D01 Power Meas License Digital Systems v03r01

All test items have been performed as a reference to the above KDB test guidance.

4 Test Types and Results

4.1 Output Power Measurement

4.1.1 Limits of Output Power Measurement

For n41:

Mobile stations are limited to 2.0 watts EIRP. All user stations are limited to 2.0 watts transmitter output power.

For n66:

Mobile / Portable station are limited to 1 watts e.i.r.p.

For n71:

Portable stations (hand-held devices) in the 600 MHz uplink band and the 698-746 MHz band, and fixed and mobile stations in the 600 MHz uplink band are limited to 3 watts ERP.

4.1.2 Test Procedures

Conducted Power Measurement:

The EUT was set up for the maximum power with 5GNR link data modulation and link up with simulator.

Set the EUT to transmit under low, middle and high channel and record the power level shown on simulator.

Maximum EIRP / ERP

The relevant equation for determining the maximum ERP or EIRP from the measured RF output power is given in Equation as follows:

$$\text{EIRP} = P_{\text{Meas}} + G_{\text{T}}$$

$$\text{ERP} = P_{\text{Meas}} + G_{\text{T}} - 2.15$$

where

ERP or EIRP effective radiated power or equivalent isotropically radiated power, respectively

(expressed in the same units as P_{Meas} , e.g., dBm or dBW)

P_{Meas} measured transmitter output power or PSD, in dBm or dBW

G_{T} gain of the transmitting antenna, in dBd (ERP) or dBi (EIRP)

4.1.3 Test Setup

Conducted Power Measurement:



4.1.4 Test Results

Conducted Output Power (dBm)

NR Band 41 (Power Class 2)						
BW	MCS Index	RB Size	RB Offset	Low	Mid	High
		Channel		509202	518598	528000
		Frequency (MHz)		2546.01	2592.99	2640
100M	$\pi/2$ BPSK	1	1	26.81	26.88	25.47
100M	QPSK	1	1	26.94	26.91	25.81
		1	137	25.38	25.32	25.41
		1	271	26.58	25.88	25.32
		135	0	25.84	25.64	25.33
		135	69	25.77	25.26	25.27
		135	138	25.05	25.11	25.11
		270	0	25.88	25.68	25.47
100M	16QAM	1	1	23.12	22.85	23.22
100M	64QAM	1	1	22.34	22.65	22.43
100M	256QAM	1	1	21.45	21.66	21.42
BW	MCS Index	Channel		508200	518598	528996
		Frequency (MHz)		2541	2592.99	2644.98
		90M	$\pi/2$ BPSK	1	1	26.78
90M	QPSK	1	1	26.91	26.88	25.78
		1	123	25.35	25.29	25.38
		1	243	26.55	25.85	25.29
		120	0	25.74	25.61	25.30
		120	63	25.09	25.23	25.24
		120	125	25.02	25.08	25.08
		243	0	25.71	25.65	25.44
90M	16QAM	1	1	23.09	22.82	23.19
90M	64QAM	1	1	22.31	22.62	22.40
90M	256QAM	1	1	21.42	21.63	21.39
BW	MCS Index	Channel		507204	518598	529998
		Frequency (MHz)		2536.02	2592.99	2649.99
		80M	$\pi/2$ BPSK	1	1	26.74
80M	QPSK	1	1	26.87	26.84	25.74
		1	109	25.31	25.25	25.34
		1	215	26.51	25.81	25.25
		108	0	25.70	25.57	25.26
		108	55	25.05	25.19	25.20
		108	109	24.98	25.04	25.04
		216	0	25.67	25.61	25.40
80M	16QAM	1	1	23.05	22.78	23.15
80M	64QAM	1	1	22.27	22.58	22.36
80M	256QAM	1	1	21.38	21.59	21.35

NR Band 41 (Power Class 2)						
BW	MCS Index	RB Size	RB Offset	Low	Mid	High
		Channel		505200	518598	531996
		Frequency (MHz)		2526	2592.99	2659.98
60M	$\pi/2$ BPSK	1	1	26.69	26.76	25.35
60M	QPSK	1	1	26.82	26.79	25.69
		1	81	25.26	25.20	25.29
		1	160	26.46	25.76	25.20
		81	0	25.65	25.52	25.21
		81	41	25.00	25.14	25.15
		81	81	24.93	24.99	24.99
		162	0	25.62	25.56	25.35
60M	16QAM	1	1	23.00	22.73	23.10
60M	64QAM	1	1	22.22	22.53	22.31
60M	256QAM	1	1	21.33	21.54	21.30
BW	MCS Index	Channel		504204	518598	532998
		Frequency (MHz)		2521.02	2592.99	2664.99
		50M	$\pi/2$ BPSK	1	1	26.67
50M	QPSK	1	1	26.80	26.77	25.67
		1	67	25.24	25.18	25.27
		1	131	26.44	25.74	25.18
		64	0	25.63	25.50	25.19
		64	35	24.98	25.12	25.13
		64	69	24.91	24.97	24.97
		128	0	25.60	25.54	25.33
50M	16QAM	1	1	22.98	22.71	23.08
50M	64QAM	1	1	22.20	22.51	22.29
50M	256QAM	1	1	21.31	21.52	21.28
BW	MCS Index	Channel		503202	518598	534000
		Frequency (MHz)		2516.01	2592.99	2670
		40M	$\pi/2$ BPSK	1	1	26.65
40M	QPSK	1	1	26.78	26.75	25.65
		1	53	25.22	25.16	25.25
		1	104	26.42	25.72	25.16
		50	0	25.61	25.48	25.17
		50	28	24.96	25.10	25.11
		50	56	24.89	24.95	24.95
		100	0	25.58	25.52	25.31
40M	16QAM	1	1	22.96	22.69	23.06
40M	64QAM	1	1	22.18	22.49	22.27
40M	256QAM	1	1	21.29	21.50	21.26

NR Band 41 (Power Class 2)						
BW	MCS Index	RB Size	RB Offset	Low	Mid	High
		Channel		501204	518598	535998
		Frequency (MHz)		2506.02	2592.99	2679.99
20M	$\pi/2$ BPSK	1	1	26.60	26.67	25.26
20M	QPSK	1	1	26.73	26.70	25.60
		1	26	25.17	25.11	25.20
		1	49	26.37	25.67	25.11
		25	0	25.56	25.43	25.12
		25	13	24.91	25.05	25.06
		25	26	24.84	24.90	24.90
		50	0	25.53	25.47	25.26
20M	16QAM	1	1	22.91	22.64	23.01
20M	64QAM	1	1	22.13	22.44	22.22
20M	256QAM	1	1	21.24	21.45	21.21
BW	MCS Index	Channel		500700	518598	536496
		Frequency (MHz)		2503.5	2592.99	2682.48
		15M	$\pi/2$ BPSK	1	1	26.57
15M	QPSK	1	1	26.70	26.67	25.57
		1	19	25.14	25.08	25.17
		1	36	26.34	25.64	25.08
		18	0	25.53	25.40	25.09
		18	10	24.88	25.02	25.03
		18	20	24.81	24.87	24.87
		36	0	25.50	25.44	25.23
15M	16QAM	1	1	22.88	22.61	22.98
15M	64QAM	1	1	22.10	22.41	22.19
15M	256QAM	1	1	21.21	21.42	21.18
BW	MCS Index	Channel		500202	518598	537000
		Frequency (MHz)		2501.01	2592.99	2685
		10M	$\pi/2$ BPSK	1	1	26.55
10M	QPSK	1	1	26.68	26.65	25.55
		1	11	25.12	25.06	25.15
		1	22	26.32	25.62	25.06
		12	0	25.51	25.38	25.07
		12	6	24.86	25.00	25.01
		12	12	24.79	24.85	24.85
		24	0	25.48	25.42	25.21
10M	16QAM	1	1	22.86	22.59	22.96
10M	64QAM	1	1	22.08	22.39	22.17
10M	256QAM	1	1	21.19	21.40	21.16

NR Band 41 (Power Class 3)						
BW	MCS Index	RB Size	RB Offset	Low	Mid	High
		Channel		509202	518598	528000
		Frequency (MHz)		2546.01	2592.99	2640
100M	$\pi/2$ BPSK	1	1	23.62	23.49	22.13
100M	QPSK	1	1	23.71	23.54	22.37
		1	137	21.99	22.03	22.01
		1	271	23.45	22.46	21.86
		135	0	22.43	22.53	21.94
		135	69	22.36	21.89	21.82
		135	138	21.59	21.88	21.75
		270	0	22.63	22.42	22.13
100M	16QAM	1	1	19.92	19.57	20.01
100M	64QAM	1	1	18.91	19.37	19.19
100M	256QAM	1	1	18.21	18.29	18.01
BW	MCS Index	Channel		508200	518598	528996
		Frequency (MHz)		2541	2592.99	2644.98
90M	$\pi/2$ BPSK	1	1	23.58	23.47	22.14
90M	QPSK	1	1	23.44	23.68	22.63
		1	123	22.05	21.81	22.15
		1	243	23.39	22.48	21.80
		120	0	22.49	22.51	22.08
		120	63	21.76	21.86	21.95
		120	125	21.74	21.79	21.69
		243	0	22.37	22.52	22.09
90M	16QAM	1	1	19.96	19.53	19.89
90M	64QAM	1	1	18.97	19.46	19.26
90M	256QAM	1	1	18.06	18.26	18.07
BW	MCS Index	Channel		507204	518598	529998
		Frequency (MHz)		2536.02	2592.99	2649.99
80M	$\pi/2$ BPSK	1	1	23.45	23.56	21.95
80M	QPSK	1	1	23.43	23.68	22.44
		1	109	21.82	21.90	22.11
		1	215	23.33	22.43	21.86
		108	0	22.55	22.38	21.79
		108	55	21.64	22.02	21.81
		108	109	21.54	21.63	21.94
		216	0	22.19	22.29	22.08
80M	16QAM	1	1	19.70	19.33	19.73
80M	64QAM	1	1	18.80	19.23	19.05
80M	256QAM	1	1	17.88	18.20	18.01

NR Band 41 (Power Class 3)						
BW	MCS Index	RB Size	RB Offset	Low	Mid	High
		Channel		505200	518598	531996
		Frequency (MHz)		2526	2592.99	2659.98
60M	$\pi/2$ BPSK	1	1	23.21	23.32	22.01
60M	QPSK	1	1	23.56	23.33	22.48
		1	81	21.90	21.74	21.92
		1	160	23.33	22.28	21.97
		81	0	22.15	22.19	21.81
		81	41	21.66	21.83	21.79
		81	81	21.69	21.77	21.83
		162	0	22.39	22.20	22.06
60M	16QAM	1	1	19.60	19.62	19.93
60M	64QAM	1	1	19.04	19.38	18.87
60M	256QAM	1	1	17.96	18.06	18.13
BW	MCS Index	Channel		504204	518598	532998
		Frequency (MHz)		2521.02	2592.99	2664.99
		50M	$\pi/2$ BPSK	1	1	23.57
50M	QPSK	1	1	23.58	23.40	22.32
		1	67	22.11	22.06	21.83
		1	131	23.11	22.38	21.78
		64	0	22.24	22.11	21.84
		64	35	21.50	21.96	21.92
		64	69	21.55	21.62	21.61
		128	0	22.11	22.14	21.90
50M	16QAM	1	1	19.87	19.52	19.69
50M	64QAM	1	1	18.91	19.20	18.80
50M	256QAM	1	1	17.96	18.25	18.18
BW	MCS Index	Channel		503202	518598	534000
		Frequency (MHz)		2516.01	2592.99	2670
		40M	$\pi/2$ BPSK	1	1	23.19
40M	QPSK	1	1	23.60	23.41	22.24
		1	53	22.07	21.94	21.98
		1	104	23.23	22.46	21.70
		50	0	22.12	22.15	21.89
		50	28	21.63	21.85	21.74
		50	56	21.67	21.72	21.64
		100	0	22.22	22.34	22.10
40M	16QAM	1	1	19.72	19.56	19.87
40M	64QAM	1	1	18.77	19.21	18.85
40M	256QAM	1	1	17.88	18.35	18.11

NR Band 41 (Power Class 3)						
BW	MCS Index	RB Size	RB Offset	Low	Mid	High
		Channel		501204	518598	535998
		Frequency (MHz)		2506.02	2592.99	2679.99
20M	$\pi/2$ BPSK	1	1	23.16	23.46	22.06
20M	QPSK	1	1	23.57	23.37	22.28
		1	26	21.75	21.95	21.71
		1	49	23.25	22.54	22.01
		25	0	22.09	22.16	21.80
		25	13	21.72	21.81	21.76
		25	26	21.67	21.62	21.48
		50	0	22.25	22.08	21.99
20M	16QAM	1	1	19.72	19.14	19.90
20M	64QAM	1	1	19.02	19.02	18.81
20M	256QAM	1	1	17.83	18.07	17.97
BW	MCS Index	Channel		500700	518598	536496
		Frequency (MHz)		2503.5	2592.99	2682.48
		15M	$\pi/2$ BPSK	1	1	23.42
15M	QPSK	1	1	23.56	23.57	22.36
		1	19	21.83	21.87	21.82
		1	36	23.07	22.14	21.87
		18	0	22.05	21.92	21.63
		18	10	21.55	21.58	21.62
		18	20	21.44	21.37	21.70
		36	0	22.30	22.33	22.05
15M	16QAM	1	1	19.40	19.49	19.68
15M	64QAM	1	1	18.65	19.14	19.08
15M	256QAM	1	1	17.74	18.07	17.74
BW	MCS Index	Channel		500202	518598	537000
		Frequency (MHz)		2501.01	2592.99	2685
		10M	$\pi/2$ BPSK	1	1	23.29
10M	QPSK	1	1	23.19	23.17	22.31
		1	11	21.78	21.75	21.66
		1	22	23.20	22.52	21.81
		12	0	22.14	22.08	21.67
		12	6	21.42	21.77	21.58
		12	12	21.59	21.45	21.66
		24	0	22.09	22.16	21.85
10M	16QAM	1	1	19.71	19.31	19.49
10M	64QAM	1	1	18.84	19.20	18.80
10M	256QAM	1	1	17.75	17.97	17.93

NR Band 66						
BW	MCS Index	RB Size	RB Offset	Low	Mid	High
		Channel		346000	349000	352000
		Frequency (MHz)		1730	1745	1760
40M	$\pi/2$ BPSK	1	1	23.44	23.33	23.47
40M	QPSK	1	1	23.52	23.42	23.57
		1	108	23.42	23.39	23.41
		1	214	23.32	23.31	23.40
		108	0	22.27	22.33	22.41
		108	54	23.37	23.32	23.48
		108	108	22.16	22.22	22.30
		216	0	22.26	22.32	22.40
40M	16QAM	1	1	22.02	22.08	22.16
40M	64QAM	1	1	21.76	21.82	21.90
40M	256QAM	1	1	19.68	19.74	19.82
BW	MCS Index	Channel		344000	349000	354000
		Frequency (MHz)		1720	1745	1770
		20M	$\pi/2$ BPSK	1	1	23.36
20M	QPSK	1	1	23.44	23.34	23.49
		1	53	23.34	23.31	23.33
		1	104	23.24	23.23	23.32
		50	0	22.19	22.25	22.33
		50	28	23.29	23.24	23.30
		50	56	22.08	22.14	22.22
		100	0	22.18	22.24	22.32
20M	16QAM	1	1	21.94	22.00	22.08
20M	64QAM	1	1	21.68	21.74	21.82
20M	256QAM	1	1	19.60	19.66	19.74
BW	MCS Index	Channel		343500	349000	354500
		Frequency (MHz)		1717.5	1745	1772.5
		15M	$\pi/2$ BPSK	1	1	23.33
15M	QPSK	1	1	23.41	23.31	23.46
		1	40	23.31	23.28	23.30
		1	77	23.21	23.20	23.29
		36	0	22.16	22.22	22.30
		36	22	23.26	23.21	23.27
		36	43	22.05	22.11	22.19
		75	0	22.15	22.21	22.29
15M	16QAM	1	1	21.91	21.97	22.05
15M	64QAM	1	1	21.65	21.71	21.79
15M	256QAM	1	1	19.57	19.63	19.71

NR Band 66						
BW	MCS Index	RB Size	RB Offset	Low	Mid	High
		Channel		343000	349000	355000
		Frequency (MHz)		1715	1745	1775
10M	$\pi/2$ BPSK	1	1	23.29	23.18	23.32
10M	QPSK	1	1	23.37	23.27	23.42
		1	26	23.27	23.24	23.26
		1	50	23.17	23.16	23.25
		25	0	22.12	22.18	22.26
		25	14	23.22	23.17	23.23
		25	27	22.01	22.07	22.15
		50	0	22.11	22.17	22.25
10M	16QAM	1	1	21.87	21.93	22.01
10M	64QAM	1	1	21.61	21.67	21.75
10M	256QAM	1	1	19.53	19.59	19.67
BW	MCS Index	Channel		342500	349000	355500
		Frequency (MHz)		1712.5	1745	1777.5
5M	$\pi/2$ BPSK	1	1	23.27	23.16	23.30
5M	QPSK	1	1	23.35	23.25	23.40
		1	13	23.25	23.22	23.24
		1	23	23.15	23.14	23.23
		12	0	22.10	22.16	22.24
		12	7	23.20	23.15	23.21
		12	13	21.99	22.05	22.13
		25	0	22.09	22.15	22.23
5M	16QAM	1	1	21.85	21.91	21.99
5M	64QAM	1	1	21.59	21.65	21.73
5M	256QAM	1	1	19.51	19.57	19.65

NR Band 71						
BW	MCS Index	RB Size	RB Offset	Low	Mid	High
		Channel		134600	136100	137600
		Frequency (MHz)		673	680.5	688
20M	$\pi/2$ BPSK	1	1	24.44	24.38	24.24
20M	QPSK	1	1	24.50	24.46	24.40
		1	53	24.48	24.44	24.38
		1	104	24.46	24.42	24.36
		50	0	23.40	23.39	23.33
		50	28	23.43	23.36	23.30
		50	56	23.40	23.36	23.30
		100	0	23.45	23.41	23.35
20M	16QAM	1	1	23.32	23.28	23.22
20M	64QAM	1	1	21.40	21.36	21.30
20M	256QAM	1	1	19.90	19.86	19.80
BW	MCS Index	Channel		134100	136100	138100
		Frequency (MHz)		670.5	680.5	690.5
15M	$\pi/2$ BPSK	1	1	24.41	24.36	24.29
15M	QPSK	1	1	24.34	24.43	24.37
		1	40	24.44	24.32	24.29
		1	77	24.38	24.24	24.19
		36	0	23.36	23.37	23.22
		36	22	23.21	23.18	23.22
		36	43	23.32	23.30	23.12
		75	0	23.39	23.35	23.28
15M	16QAM	1	1	23.26	23.24	23.20
15M	64QAM	1	1	21.39	21.28	21.20
15M	256QAM	1	1	19.83	19.77	19.71
BW	MCS Index	Channel		133600	136100	138600
		Frequency (MHz)		668	680.5	693
10M	$\pi/2$ BPSK	1	1	24.41	24.34	24.24
10M	QPSK	1	1	24.37	24.32	24.24
		1	26	24.44	24.37	24.25
		1	50	24.29	24.30	24.29
		25	0	23.27	23.36	23.19
		25	14	23.26	23.30	23.22
		25	27	23.31	23.18	23.26
		50	0	23.39	23.31	23.24
10M	16QAM	1	1	23.30	23.22	23.16
10M	64QAM	1	1	21.33	21.31	21.28
10M	256QAM	1	1	19.81	19.84	19.80

NR Band 71						
BW	MCS Index	RB Size	RB Offset	Low	Mid	High
		Channel		133100	136100	139100
		Frequency (MHz)		665.5	680.5	695.5
5M	$\pi/2$ BPSK	1	1	24.29	24.33	24.26
5M	QPSK	1	1	24.40	24.35	24.29
		1	13	24.31	24.32	24.23
		1	23	24.28	24.35	24.25
		12	0	23.29	23.35	23.20
		12	7	23.29	23.29	23.19
		12	13	23.29	23.31	23.13
		25	0	23.41	23.28	23.19
5M	16QAM	1	1	23.28	23.24	23.22
5M	64QAM	1	1	21.30	21.26	21.27
5M	256QAM	1	1	19.90	19.80	19.72

EIRP / ERP Power (dBm)

NR Band 41 (Power Class 2)						
BW	MCS Index	RB Size	RB Offset	Low	Mid	High
		Channel		509202	518598	528000
		Frequency (MHz)		2546.01	2592.99	2640
100M	$\pi/2$ BPSK	1	1	27.66	27.73	26.32
100M	QPSK	1	1	27.79	27.76	26.66
		1	137	26.23	26.17	26.26
		1	271	27.43	26.73	26.17
		135	0	26.69	26.49	26.18
		135	69	26.62	26.11	26.12
		135	138	25.90	25.96	25.96
		270	0	26.73	26.53	26.32
100M	16QAM	1	1	23.97	23.70	24.07
100M	64QAM	1	1	23.19	23.50	23.28
100M	256QAM	1	1	22.30	22.51	22.27
BW	MCS Index	Channel		508200	518598	528996
		Frequency (MHz)		2541	2592.99	2644.98
90M	$\pi/2$ BPSK	1	1	27.63	27.70	26.29
90M	QPSK	1	1	27.76	27.73	26.63
		1	123	26.20	26.14	26.23
		1	243	27.40	26.70	26.14
		120	0	26.59	26.46	26.15
		120	63	25.94	26.08	26.09
		120	125	25.87	25.93	25.93
		243	0	26.56	26.50	26.29
90M	16QAM	1	1	23.94	23.67	24.04
90M	64QAM	1	1	23.16	23.47	23.25
90M	256QAM	1	1	22.27	22.48	22.24
BW	MCS Index	Channel		507204	518598	529998
		Frequency (MHz)		2536.02	2592.99	2649.99
80M	$\pi/2$ BPSK	1	1	27.59	27.66	26.25
80M	QPSK	1	1	27.72	27.69	26.59
		1	109	26.16	26.10	26.19
		1	215	27.36	26.66	26.10
		108	0	26.55	26.42	26.11
		108	55	25.90	26.04	26.05
		108	109	25.83	25.89	25.89
		216	0	26.52	26.46	26.25
80M	16QAM	1	1	23.90	23.63	24.00
80M	64QAM	1	1	23.12	23.43	23.21
80M	256QAM	1	1	22.23	22.44	22.20

NR Band 41 (Power Class 2)						
BW	MCS Index	RB Size	RB Offset	Low	Mid	High
		Channel		505200	518598	531996
		Frequency (MHz)		2526	2592.99	2659.98
60M	$\pi/2$ BPSK	1	1	27.54	27.61	26.20
60M	QPSK	1	1	27.67	27.64	26.54
		1	81	26.11	26.05	26.14
		1	160	27.31	26.61	26.05
		81	0	26.50	26.37	26.06
		81	41	25.85	25.99	26.00
		81	81	25.78	25.84	25.84
		162	0	26.47	26.41	26.20
60M	16QAM	1	1	23.85	23.58	23.95
60M	64QAM	1	1	23.07	23.38	23.16
60M	256QAM	1	1	22.18	22.39	22.15
BW	MCS Index	Channel		504204	518598	532998
		Frequency (MHz)		2521.02	2592.99	2664.99
50M	$\pi/2$ BPSK	1	1	27.52	27.59	26.18
50M	QPSK	1	1	27.65	27.62	26.52
		1	67	26.09	26.03	26.12
		1	131	27.29	26.59	26.03
		64	0	26.48	26.35	26.04
		64	35	25.83	25.97	25.98
		64	69	25.76	25.82	25.82
		128	0	26.45	26.39	26.18
50M	16QAM	1	1	23.83	23.56	23.93
50M	64QAM	1	1	23.05	23.36	23.14
50M	256QAM	1	1	22.16	22.37	22.13
BW	MCS Index	Channel		503202	518598	534000
		Frequency (MHz)		2516.01	2592.99	2670
40M	$\pi/2$ BPSK	1	1	27.50	27.57	26.16
40M	QPSK	1	1	27.63	27.60	26.50
		1	53	26.07	26.01	26.10
		1	104	27.27	26.57	26.01
		50	0	26.46	26.33	26.02
		50	28	25.81	25.95	25.96
		50	56	25.74	25.80	25.80
		100	0	26.43	26.37	26.16
40M	16QAM	1	1	23.81	23.54	23.91
40M	64QAM	1	1	23.03	23.34	23.12
40M	256QAM	1	1	22.14	22.35	22.11

NR Band 41 (Power Class 2)						
BW	MCS Index	RB Size	RB Offset	Low	Mid	High
		Channel		501204	518598	535998
		Frequency (MHz)		2506.02	2592.99	2679.99
20M	$\pi/2$ BPSK	1	1	27.45	27.52	26.11
20M	QPSK	1	1	27.58	27.55	26.45
		1	26	26.02	25.96	26.05
		1	49	27.22	26.52	25.96
		25	0	26.41	26.28	25.97
		25	13	25.76	25.90	25.91
		25	26	25.69	25.75	25.75
		50	0	26.38	26.32	26.11
20M	16QAM	1	1	23.76	23.49	23.86
20M	64QAM	1	1	22.98	23.29	23.07
20M	256QAM	1	1	22.09	22.30	22.06
BW	MCS Index	Channel		500700	518598	536496
		Frequency (MHz)		2503.5	2592.99	2682.48
		15M	$\pi/2$ BPSK	1	1	27.42
15M	QPSK	1	1	27.55	27.52	26.42
		1	19	25.99	25.93	26.02
		1	36	27.19	26.49	25.93
		18	0	26.38	26.25	25.94
		18	10	25.73	25.87	25.88
		18	20	25.66	25.72	25.72
		36	0	26.35	26.29	26.08
15M	16QAM	1	1	23.73	23.46	23.83
15M	64QAM	1	1	22.95	23.26	23.04
15M	256QAM	1	1	22.06	22.27	22.03
BW	MCS Index	Channel		500202	518598	537000
		Frequency (MHz)		2501.01	2592.99	2685
		10M	$\pi/2$ BPSK	1	1	27.40
10M	QPSK	1	1	27.53	27.50	26.40
		1	11	25.97	25.91	26.00
		1	22	27.17	26.47	25.91
		12	0	26.36	26.23	25.92
		12	6	25.71	25.85	25.86
		12	12	25.64	25.70	25.70
		24	0	26.33	26.27	26.06
10M	16QAM	1	1	23.71	23.44	23.81
10M	64QAM	1	1	22.93	23.24	23.02
10M	256QAM	1	1	22.04	22.25	22.01

NR Band 41 (Power Class 3)						
BW	MCS Index	RB Size	RB Offset	Low	Mid	High
		Channel		509202	518598	528000
		Frequency (MHz)		2546.01	2592.99	2640
100M	$\pi/2$ BPSK	1	1	24.47	24.34	22.98
100M	QPSK	1	1	24.56	24.39	23.22
		1	137	22.84	22.88	22.86
		1	271	24.30	23.31	22.71
		135	0	23.28	23.38	22.79
		135	69	23.21	22.74	22.67
		135	138	22.44	22.73	22.60
		270	0	23.48	23.27	22.98
100M	16QAM	1	1	20.77	20.42	20.86
100M	64QAM	1	1	19.76	20.22	20.04
100M	256QAM	1	1	19.06	19.14	18.86
BW	MCS Index	Channel		508200	518598	528996
		Frequency (MHz)		2541	2592.99	2644.98
90M	$\pi/2$ BPSK	1	1	24.43	24.32	22.99
90M	QPSK	1	1	24.29	24.53	23.48
		1	123	22.90	22.66	23.00
		1	243	24.24	23.33	22.65
		120	0	23.34	23.36	22.93
		120	63	22.61	22.71	22.80
		120	125	22.59	22.64	22.54
		243	0	23.22	23.37	22.94
90M	16QAM	1	1	20.81	20.38	20.74
90M	64QAM	1	1	19.82	20.31	20.11
90M	256QAM	1	1	18.91	19.11	18.92
BW	MCS Index	Channel		507204	518598	529998
		Frequency (MHz)		2536.02	2592.99	2649.99
80M	$\pi/2$ BPSK	1	1	24.30	24.41	22.80
80M	QPSK	1	1	24.28	24.53	23.29
		1	109	22.67	22.75	22.96
		1	215	24.18	23.28	22.71
		108	0	23.40	23.23	22.64
		108	55	22.49	22.87	22.66
		108	109	22.39	22.48	22.79
		216	0	23.04	23.14	22.93
80M	16QAM	1	1	20.55	20.18	20.58
80M	64QAM	1	1	19.65	20.08	19.90
80M	256QAM	1	1	18.73	19.05	18.86

NR Band 41 (Power Class 3)						
BW	MCS Index	RB Size	RB Offset	Low	Mid	High
		Channel		505200	518598	531996
		Frequency (MHz)		2526	2592.99	2659.98
60M	$\pi/2$ BPSK	1	1	24.06	24.17	22.86
60M	QPSK	1	1	24.41	24.18	23.33
		1	81	22.75	22.59	22.77
		1	160	24.18	23.13	22.82
		81	0	23.00	23.04	22.66
		81	41	22.51	22.68	22.64
		81	81	22.54	22.62	22.68
		162	0	23.24	23.05	22.91
60M	16QAM	1	1	20.45	20.47	20.78
60M	64QAM	1	1	19.89	20.23	19.72
60M	256QAM	1	1	18.81	18.91	18.98
BW	MCS Index	Channel		504204	518598	532998
		Frequency (MHz)		2521.02	2592.99	2664.99
		50M	$\pi/2$ BPSK	1	1	24.42
50M	QPSK	1	1	24.43	24.25	23.17
		1	67	22.96	22.91	22.68
		1	131	23.96	23.23	22.63
		64	0	23.09	22.96	22.69
		64	35	22.35	22.81	22.77
		64	69	22.40	22.47	22.46
		128	0	22.96	22.99	22.75
50M	16QAM	1	1	20.72	20.37	20.54
50M	64QAM	1	1	19.76	20.05	19.65
50M	256QAM	1	1	18.81	19.10	19.03
BW	MCS Index	Channel		503202	518598	534000
		Frequency (MHz)		2516.01	2592.99	2670
		40M	$\pi/2$ BPSK	1	1	24.04
40M	QPSK	1	1	24.45	24.26	23.09
		1	53	22.92	22.79	22.83
		1	104	24.08	23.31	22.55
		50	0	22.97	23.00	22.74
		50	28	22.48	22.70	22.59
		50	56	22.52	22.57	22.49
		100	0	23.07	23.19	22.95
40M	16QAM	1	1	20.57	20.41	20.72
40M	64QAM	1	1	19.62	20.06	19.70
40M	256QAM	1	1	18.73	19.20	18.96

NR Band 41 (Power Class 3)						
BW	MCS Index	RB Size	RB Offset	Low	Mid	High
		Channel		501204	518598	535998
		Frequency (MHz)		2506.02	2592.99	2679.99
20M	$\pi/2$ BPSK	1	1	24.01	24.31	22.91
20M	QPSK	1	1	24.42	24.22	23.13
		1	26	22.60	22.80	22.56
		1	49	24.10	23.39	22.86
		25	0	22.94	23.01	22.65
		25	13	22.57	22.66	22.61
		25	26	22.52	22.47	22.33
		50	0	23.10	22.93	22.84
20M	16QAM	1	1	20.57	19.99	20.75
20M	64QAM	1	1	19.87	19.87	19.66
20M	256QAM	1	1	18.68	18.92	18.82
BW	MCS Index	Channel		500700	518598	536496
		Frequency (MHz)		2503.5	2592.99	2682.48
		15M	$\pi/2$ BPSK	1	1	24.27
15M	QPSK	1	1	24.41	24.42	23.21
		1	19	22.68	22.72	22.67
		1	36	23.92	22.99	22.72
		18	0	22.90	22.77	22.48
		18	10	22.40	22.43	22.47
		18	20	22.29	22.22	22.55
		36	0	23.15	23.18	22.90
15M	16QAM	1	1	20.25	20.34	20.53
15M	64QAM	1	1	19.50	19.99	19.93
15M	256QAM	1	1	18.59	18.92	18.59
BW	MCS Index	Channel		500202	518598	537000
		Frequency (MHz)		2501.01	2592.99	2685
		10M	$\pi/2$ BPSK	1	1	24.14
10M	QPSK	1	1	24.04	24.02	23.16
		1	11	22.63	22.60	22.51
		1	22	24.05	23.37	22.66
		12	0	22.99	22.93	22.52
		12	6	22.27	22.62	22.43
		12	12	22.44	22.30	22.51
		24	0	22.94	23.01	22.70
10M	16QAM	1	1	20.56	20.16	20.34
10M	64QAM	1	1	19.69	20.05	19.65
10M	256QAM	1	1	18.60	18.82	18.78

NR Band 66						
BW	MCS Index	RB Size	RB Offset	Low	Mid	High
		Channel		346000	349000	352000
		Frequency (MHz)		1730	1745	1760
40M	$\pi/2$ BPSK	1	1	26.60	26.49	26.63
40M	QPSK	1	1	26.68	26.58	26.73
		1	108	26.58	26.55	26.57
		1	214	26.48	26.47	26.56
		108	0	25.43	25.49	25.57
		108	54	26.53	26.48	26.64
		108	108	25.32	25.38	25.46
		216	0	25.42	25.48	25.56
40M	16QAM	1	1	25.18	25.24	25.32
40M	64QAM	1	1	24.92	24.98	25.06
40M	256QAM	1	1	22.84	22.90	22.98
BW	MCS Index	Channel		344000	349000	354000
		Frequency (MHz)		1720	1745	1770
20M	$\pi/2$ BPSK	1	1	26.52	26.41	26.55
20M	QPSK	1	1	26.60	26.50	26.65
		1	53	26.50	26.47	26.49
		1	104	26.40	26.39	26.48
		50	0	25.35	25.41	25.49
		50	28	26.45	26.40	26.46
		50	56	25.24	25.30	25.38
		100	0	25.34	25.40	25.48
20M	16QAM	1	1	25.10	25.16	25.24
20M	64QAM	1	1	24.84	24.90	24.98
20M	256QAM	1	1	22.76	22.82	22.90
BW	MCS Index	Channel		343500	349000	354500
		Frequency (MHz)		1717.5	1745	1772.5
15M	$\pi/2$ BPSK	1	1	26.49	26.38	26.52
15M	QPSK	1	1	26.57	26.47	26.62
		1	40	26.47	26.44	26.46
		1	77	26.37	26.36	26.45
		36	0	25.32	25.38	25.46
		36	22	26.42	26.37	26.43
		36	43	25.21	25.27	25.35
		75	0	25.31	25.37	25.45
15M	16QAM	1	1	25.07	25.13	25.21
15M	64QAM	1	1	24.81	24.87	24.95
15M	256QAM	1	1	22.73	22.79	22.87

NR Band 66						
BW	MCS Index	RB Size	RB Offset	Low	Mid	High
		Channel		343000	349000	355000
		Frequency (MHz)		1715	1745	1775
10M	$\pi/2$ BPSK	1	1	26.45	26.34	26.48
10M	QPSK	1	1	26.53	26.43	26.58
		1	26	26.43	26.40	26.42
		1	50	26.33	26.32	26.41
		25	0	25.28	25.34	25.42
		25	14	26.38	26.33	26.39
		25	27	25.17	25.23	25.31
		50	0	25.27	25.33	25.41
10M	16QAM	1	1	25.03	25.09	25.17
10M	64QAM	1	1	24.77	24.83	24.91
10M	256QAM	1	1	22.69	22.75	22.83
BW	MCS Index	Channel		342500	349000	355500
		Frequency (MHz)		1712.5	1745	1777.5
5M	$\pi/2$ BPSK	1	1	26.43	26.32	26.46
5M	QPSK	1	1	26.51	26.41	26.56
		1	13	26.41	26.38	26.40
		1	23	26.31	26.30	26.39
		12	0	25.26	25.32	25.40
		12	7	26.36	26.31	26.37
		12	13	25.15	25.21	25.29
		25	0	25.25	25.31	25.39
5M	16QAM	1	1	25.01	25.07	25.15
5M	64QAM	1	1	24.75	24.81	24.89
5M	256QAM	1	1	22.67	22.73	22.81

NR Band 71						
BW	MCS Index	RB Size	RB Offset	Low	Mid	High
		Channel		134600	136100	137600
		Frequency (MHz)		673	680.5	688
20M	$\pi/2$ BPSK	1	1	22.72	22.66	22.52
20M	QPSK	1	1	22.78	22.74	22.68
		1	53	22.76	22.72	22.66
		1	104	22.74	22.70	22.64
		50	0	21.68	21.67	21.61
		50	28	21.71	21.64	21.58
		50	56	21.68	21.64	21.58
		100	0	21.73	21.69	21.63
20M	16QAM	1	1	21.60	21.56	21.50
20M	64QAM	1	1	19.68	19.64	19.58
20M	256QAM	1	1	18.18	18.14	18.08
BW	MCS Index	Channel		134100	136100	138100
		Frequency (MHz)		670.5	680.5	690.5
15M	$\pi/2$ BPSK	1	1	22.69	22.64	22.57
15M	QPSK	1	1	22.62	22.71	22.65
		1	40	22.72	22.60	22.57
		1	77	22.66	22.52	22.47
		36	0	21.64	21.65	21.50
		36	22	21.49	21.46	21.50
		36	43	21.60	21.58	21.40
		75	0	21.67	21.63	21.56
15M	16QAM	1	1	21.54	21.52	21.48
15M	64QAM	1	1	19.67	19.56	19.48
15M	256QAM	1	1	18.11	18.05	17.99
BW	MCS Index	Channel		133600	136100	138600
		Frequency (MHz)		668	680.5	693
10M	$\pi/2$ BPSK	1	1	22.69	22.62	22.52
10M	QPSK	1	1	22.65	22.60	22.52
		1	26	22.72	22.65	22.53
		1	50	22.57	22.58	22.57
		25	0	21.55	21.64	21.47
		25	14	21.54	21.58	21.50
		25	27	21.59	21.46	21.54
		50	0	21.67	21.59	21.52
10M	16QAM	1	1	21.58	21.50	21.44
10M	64QAM	1	1	19.61	19.59	19.56
10M	256QAM	1	1	18.09	18.12	18.08

NR Band 71						
BW	MCS Index	RB Size	RB Offset	Low	Mid	High
		Channel		133100	136100	139100
		Frequency (MHz)		665.5	680.5	695.5
5M	$\pi/2$ BPSK	1	1	22.57	22.61	22.54
5M	QPSK	1	1	22.68	22.63	22.57
		1	13	22.59	22.60	22.51
		1	23	22.56	22.63	22.53
		12	0	21.57	21.63	21.48
		12	7	21.57	21.57	21.47
		12	13	21.57	21.59	21.41
		25	0	21.69	21.56	21.47
5M	16QAM	1	1	21.56	21.52	21.50
5M	64QAM	1	1	19.58	19.54	19.55
5M	256QAM	1	1	18.18	18.08	18.00

4.2 Modulation Characteristics Measurement

4.2.1 Limits of Modulation Characteristics

N/A

4.2.2 Test Procedure

Connect the EUT to Communication Simulator via the antenna connector, The frequency band is set as EUT supported Modulation and Channels, the EUT output is matched with 50 ohm load, the waveform quality and constellation of the EUT was tested.

4.2.3 Test Setup

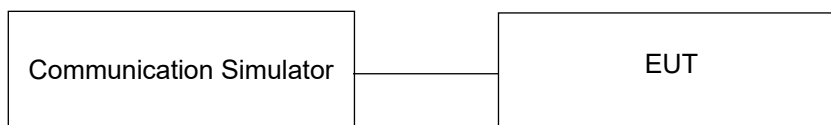

4.2.4 Test Results



n66

Spectrum Plot of Measurement Value

Channel: 349000 / Frequency (MHz): 1745.0MHz

$\pi/2$ BPSK

QPSK

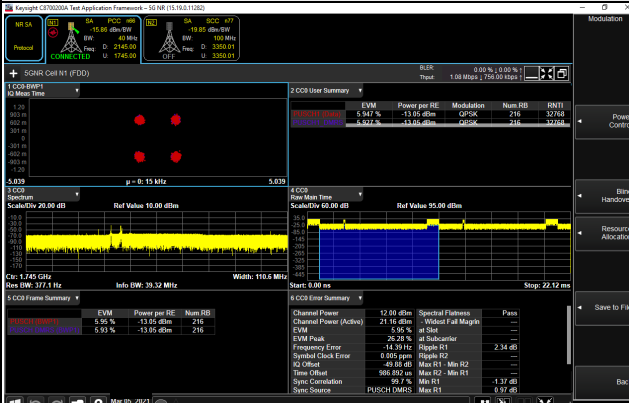
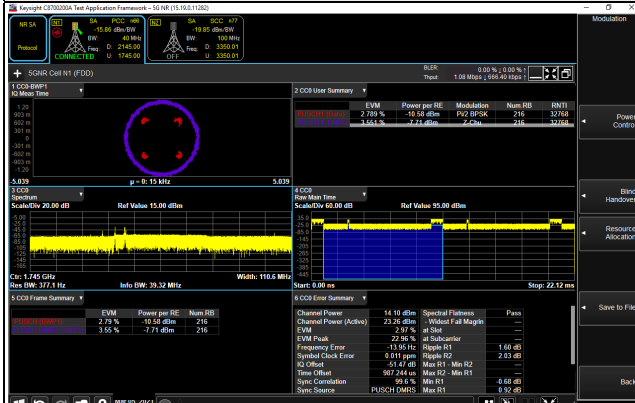

16QAM

64QAM

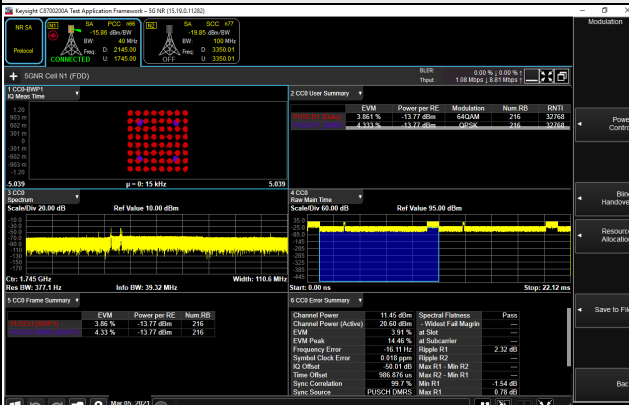
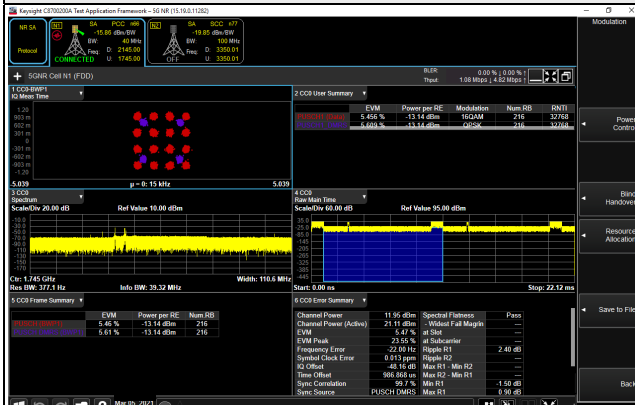

256QAM

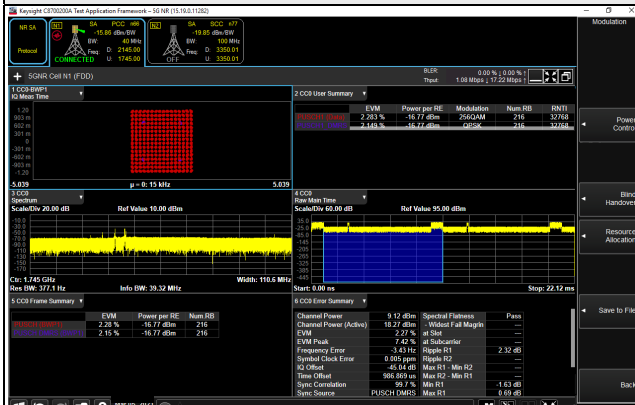

n71

Spectrum Plot of Measurement Value

Channel: 136100 / Frequency (MHz): 680.5MHz

$\pi/2$ BPSK

QPSK

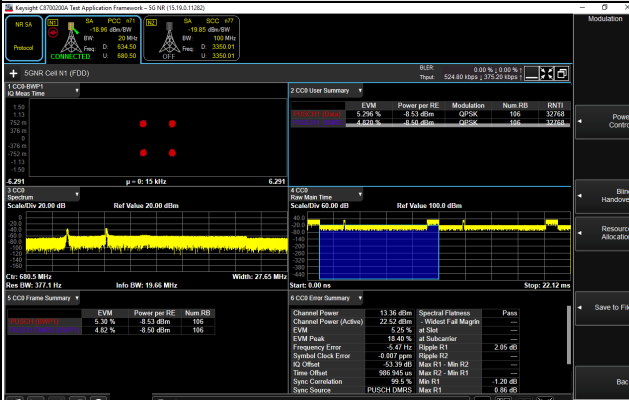
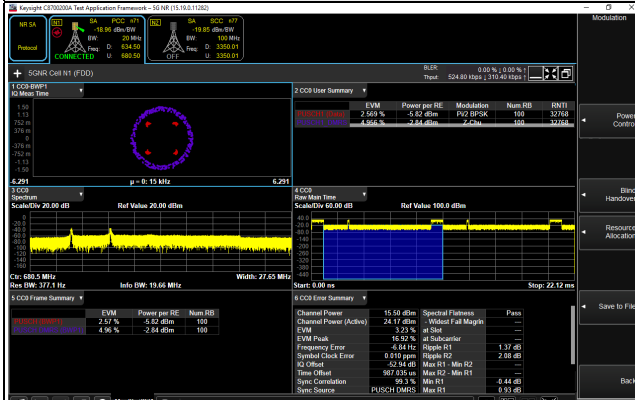

16QAM

64QAM

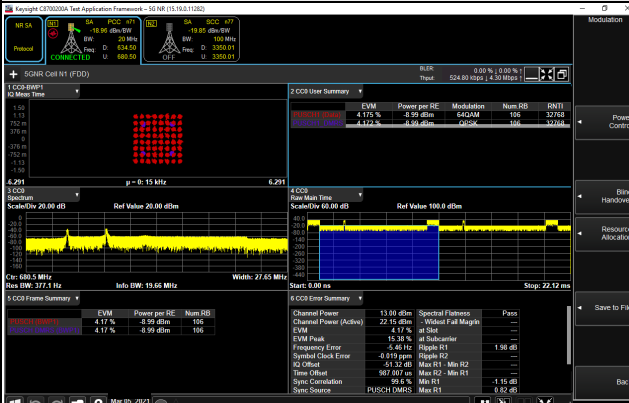
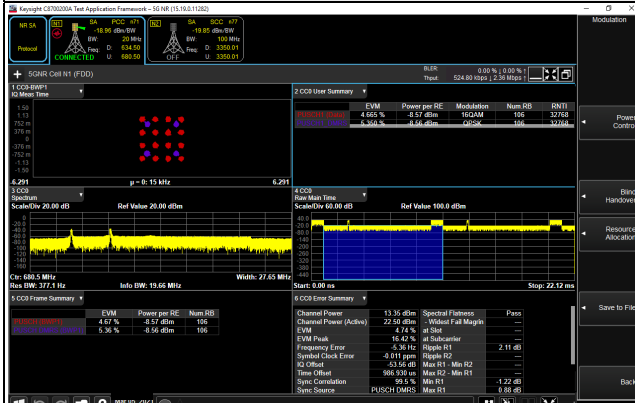

256QAM

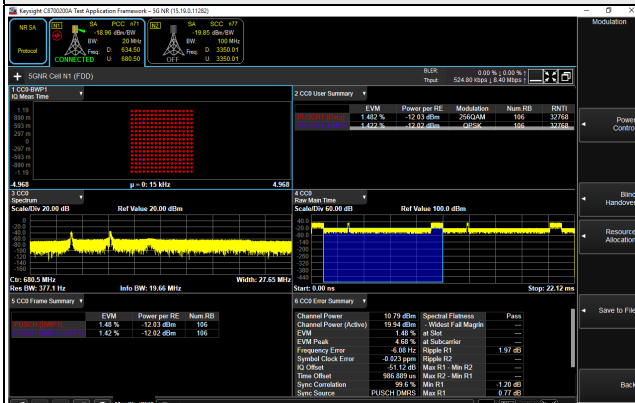

4.3 Frequency Stability Measurement

4.3.1 Limits of Frequency Stability Measurement

According to the FCC part 2.1055 shall be tested the frequency stability. The rule is defined that "The frequency stability shall be sufficient to ensure that the fundamental emission stays within the authorized frequency block." The test extreme voltage is according to the 2.1055(d)(1) Vary primary supply voltage from 85 to 115 percent of the nominal value for other than hand carried battery equipment and the extreme temperature rule is comply with specification of EUT $-30^{\circ}\text{C} \sim 50^{\circ}\text{C}$.

4.3.2 Test Procedure

- Device is placed at the oven room. The oven room could control the temperatures and humidity. Power warm up is at least 15 min and power applied should perform before recording frequency error.
- EUT is connected the external power supply to control the DC input power. The test voltage range is from minimum to maximum working voltage. Each step shall be record the frequency error rate.
- The temperature range step is 10 degrees in this test items. All temperature levels shall be hold the $\pm 0.5^{\circ}\text{C}$ during the measurement testing. The each temperature step shall be at least 0.5 hours, consider the EUT could be test under the stability condition.

Note: The frequency error was recorded frequency error from the communication simulator.

4.3.3 Test Setup

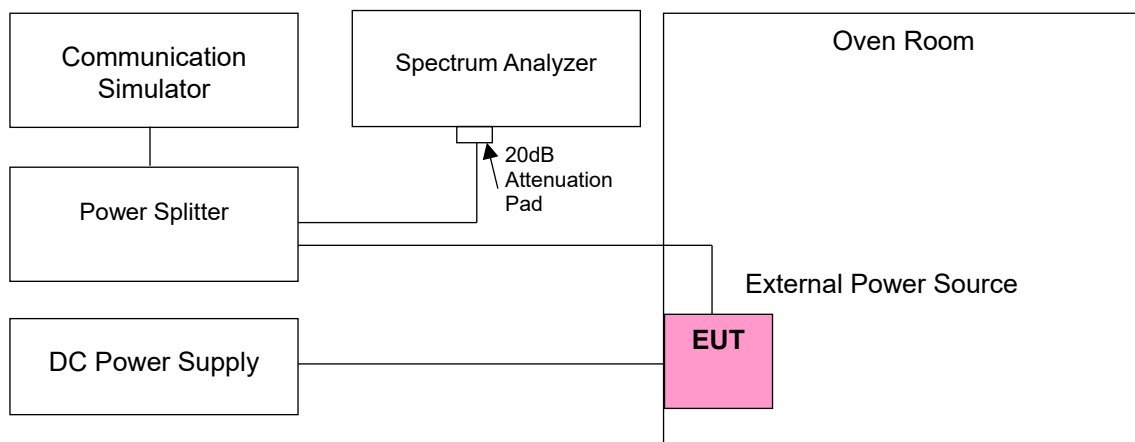

4.3.4 Test Results

Frequency Error vs. Voltage

Voltage (Vdc)	n41			
	Channel Bandwidth 10 MHz			
	Low Channel		High Channel	
	Frequency (MHz)	Frequency Error (ppm)	Frequency (MHz)	Frequency Error (ppm)
4.43	2501.010003	0.001	2685.000003	0.001
3.85	2501.010004	0.001	2685.000003	0.001
3.28	2501.010004	0.002	2685.000003	0.001

Note: The applicant defined the normal working voltage is from 3.28Vdc to 4.43Vdc.

Frequency Error vs. Temperature

Temp. (°C)	n41			
	Channel Bandwidth 10 MHz			
	Low Channel		High Channel	
	Frequency (MHz)	Frequency Error (ppm)	Frequency (MHz)	Frequency Error (ppm)
-30	2501.010002	0.001	2685.000003	0.001
-20	2501.010001	0.000	2685.000002	0.001
-10	2501.010003	0.001	2685.000002	0.001
0	2501.010004	0.001	2685.000002	0.001
10	2501.009999	-0.001	2684.999998	-0.001
20	2501.009997	-0.001	2684.999997	-0.001
30	2501.009999	-0.001	2684.999998	-0.001
40	2501.009996	-0.002	2684.999998	-0.001
50	2501.009999	-0.001	2684.999998	-0.001

Frequency Error vs. Voltage

Voltage (Vdc)	n41			
	Channel Bandwidth 15 MHz			
	Low Channel		High Channel	
	Frequency (MHz)	Frequency Error (ppm)	Frequency (MHz)	Frequency Error (ppm)
4.43	2503.500002	0.001	2682.480003	0.001
3.85	2503.500002	0.001	2682.480004	0.001
3.28	2503.500001	0.001	2682.480002	0.001

Note: The applicant defined the normal working voltage is from 3.28Vdc to 4.43Vdc.

Frequency Error vs. Temperature

Temp. (°C)	n41			
	Channel Bandwidth 15 MHz			
	Low Channel		High Channel	
	Frequency (MHz)	Frequency Error (ppm)	Frequency (MHz)	Frequency Error (ppm)
-30	2506.020003	0.001	2682.480003	0.001
-20	2503.500003	0.001	2682.480004	0.001
-10	2503.500002	0.001	2682.480001	0.000
0	2503.500003	0.001	2682.480003	0.001
10	2503.499997	-0.001	2682.479998	-0.001
20	2503.499997	-0.001	2682.479998	-0.001
30	2503.499996	-0.002	2682.479999	0.000
40	2503.499999	0.000	2682.479997	-0.001
50	2503.499996	-0.002	2682.479996	-0.001

Frequency Error vs. Voltage

Voltage (Vdc)	n41			
	Channel Bandwidth 20 MHz			
	Low Channel		High Channel	
	Frequency (MHz)	Frequency Error (ppm)	Frequency (MHz)	Frequency Error (ppm)
4.43	2506.020002	0.001	2679.990003	0.001
3.85	2506.020004	0.001	2679.990003	0.001
3.28	2506.020002	0.001	2679.990001	0.000

Note: The applicant defined the normal working voltage is from 3.28Vdc to 4.43Vdc.

Frequency Error vs. Temperature

Temp. (°C)	n41			
	Channel Bandwidth 20 MHz			
	Low Channel		High Channel	
	Frequency (MHz)	Frequency Error (ppm)	Frequency (MHz)	Frequency Error (ppm)
-30	2506.020003	0.001	2679.990002	0.001
-20	2506.020004	0.001	2679.990004	0.001
-10	2506.020003	0.001	2679.990003	0.001
0	2506.020002	0.001	2679.990002	0.001
10	2506.019997	-0.001	2679.989999	-0.001
20	2506.019997	-0.001	2679.989998	-0.001
30	2506.019998	-0.001	2679.989997	-0.001
40	2506.019998	-0.001	2679.989997	-0.001
50	2506.019998	-0.001	2679.989997	-0.001

Frequency Error vs. Voltage

Voltage (Vdc)	n41			
	Channel Bandwidth 40 MHz			
	Low Channel		High Channel	
	Frequency (MHz)	Frequency Error (ppm)	Frequency (MHz)	Frequency Error (ppm)
4.43	2516.010002	0.001	2670.000002	0.001
3.85	2516.010003	0.001	2670.000003	0.001
3.28	2516.010003	0.001	2670.000001	0.000

Note: The applicant defined the normal working voltage is from 3.28Vdc to 4.43Vdc.

Frequency Error vs. Temperature

Temp. (°C)	n41			
	Channel Bandwidth 40 MHz			
	Low Channel		High Channel	
	Frequency (MHz)	Frequency Error (ppm)	Frequency (MHz)	Frequency Error (ppm)
-30	2516.010004	0.001	2670.000003	0.001
-20	2516.010002	0.001	2670.000001	0.000
-10	2516.010002	0.001	2670.000001	0.000
0	2516.010002	0.001	2670.000004	0.001
10	2516.009997	-0.001	2669.999999	0.000
20	2516.009997	-0.001	2669.999997	-0.001
30	2516.009997	-0.001	2669.999997	-0.001
40	2516.009999	-0.001	2669.999997	-0.001
50	2516.009997	-0.001	2669.999996	-0.001

Frequency Error vs. Voltage

Voltage (Vdc)	n41			
	Channel Bandwidth 50 MHz			
	Low Channel		High Channel	
	Frequency (MHz)	Frequency Error (ppm)	Frequency (MHz)	Frequency Error (ppm)
4.43	2521.020002	0.001	2664.990004	0.001
3.85	2521.020002	0.001	2664.990003	0.001
3.28	2521.020004	0.002	2664.990002	0.001

Note: The applicant defined the normal working voltage is from 3.28Vdc to 4.43Vdc.

Frequency Error vs. Temperature

Temp. (°C)	n41			
	Channel Bandwidth 50 MHz			
	Low Channel		High Channel	
	Frequency (MHz)	Frequency Error (ppm)	Frequency (MHz)	Frequency Error (ppm)
-30	2521.020001	0.000	2664.990004	0.001
-20	2521.020002	0.001	2664.990004	0.001
-10	2521.020001	0.000	2664.990003	0.001
0	2521.020003	0.001	2664.990003	0.001
10	2521.019999	-0.001	2664.989997	-0.001
20	2521.019998	-0.001	2664.989998	-0.001
30	2521.019997	-0.001	2664.989996	-0.001
40	2521.019996	-0.002	2664.989999	-0.001
50	2521.019999	-0.001	2664.989996	-0.001

Frequency Error vs. Voltage

Voltage (Vdc)	n41			
	Channel Bandwidth 60 MHz			
	Low Channel		High Channel	
	Frequency (MHz)	Frequency Error (ppm)	Frequency (MHz)	Frequency Error (ppm)
4.43	2526.000003	0.001	2659.980001	0.001
3.85	2526.000004	0.001	2659.980002	0.001
3.28	2526.000002	0.001	2659.980002	0.001

Note: The applicant defined the normal working voltage is from 3.28Vdc to 4.43Vdc.

Frequency Error vs. Temperature

Temp. (°C)	n41			
	Channel Bandwidth 60 MHz			
	Low Channel		High Channel	
	Frequency (MHz)	Frequency Error (ppm)	Frequency (MHz)	Frequency Error (ppm)
-30	2526.000003	0.001	2659.980004	0.001
-20	2526.000001	0.000	2659.980003	0.001
-10	2526.000002	0.001	2659.980004	0.001
0	2526.000002	0.001	2659.980003	0.001
10	2525.999997	-0.001	2659.979999	0.000
20	2525.999999	0.000	2659.979997	-0.001
30	2525.999997	-0.001	2659.979996	-0.001
40	2525.999998	-0.001	2659.979997	-0.001
50	2525.999998	-0.001	2659.979996	-0.001

Frequency Error vs. Voltage

Voltage (Vdc)	n41			
	Channel Bandwidth 80 MHz			
	Low Channel		High Channel	
	Frequency (MHz)	Frequency Error (ppm)	Frequency (MHz)	Frequency Error (ppm)
4.43	2536.020004	0.002	2649.990002	0.001
3.85	2536.020003	0.001	2649.990004	0.001
3.28	2536.020001	0.001	2649.990003	0.001

Note: The applicant defined the normal working voltage is from 3.28Vdc to 4.43Vdc.

Frequency Error vs. Temperature

Temp. (°C)	n41			
	Channel Bandwidth 80 MHz			
	Low Channel		High Channel	
	Frequency (MHz)	Frequency Error (ppm)	Frequency (MHz)	Frequency Error (ppm)
-30	2536.020002	0.001	2649.990003	0.001
-20	2536.020002	0.001	2649.990002	0.001
-10	2536.020002	0.001	2649.990004	0.001
0	2536.020002	0.001	2649.990004	0.001
10	2536.019999	-0.001	2649.989999	-0.001
20	2536.019997	-0.001	2649.989998	-0.001
30	2536.019998	-0.001	2649.989999	0.000
40	2536.019998	-0.001	2649.989999	0.000
50	2536.019998	-0.001	2649.989997	-0.001

Frequency Error vs. Voltage

Voltage (Vdc)	n41			
	Channel Bandwidth 90 MHz			
	Low Channel		High Channel	
	Frequency (MHz)	Frequency Error (ppm)	Frequency (MHz)	Frequency Error (ppm)
4.43	2541.000001	0.000	2644.980004	0.001
3.85	2541.000002	0.001	2644.980003	0.001
3.28	2541.000001	0.000	2644.980001	0.000

Note: The applicant defined the normal working voltage is from 3.28Vdc to 4.43Vdc.

Frequency Error vs. Temperature

Temp. (°C)	n41			
	Channel Bandwidth 90 MHz			
	Low Channel		High Channel	
	Frequency (MHz)	Frequency Error (ppm)	Frequency (MHz)	Frequency Error (ppm)
-30	2541.000001	0.001	2644.980001	0.000
-20	2541.000002	0.001	2644.980001	0.000
-10	2541.000002	0.001	2644.980003	0.001
0	2541.000003	0.001	2644.980004	0.001
10	2540.999998	-0.001	2644.979998	-0.001
20	2540.999998	-0.001	2644.979999	-0.001
30	2540.999998	-0.001	2644.979999	0.000
40	2540.999996	-0.002	2644.979998	-0.001
50	2540.999997	-0.001	2644.979999	0.000

Frequency Error vs. Voltage

Voltage (Vdc)	n41			
	Channel Bandwidth 100 MHz			
	Low Channel		High Channel	
	Frequency (MHz)	Frequency Error (ppm)	Frequency (MHz)	Frequency Error (ppm)
4.43	2546.010004	0.002	2640.000003	0.001
3.85	2546.010002	0.001	2640.000002	0.001
3.28	2546.010001	0.001	2640.000003	0.001

Note: The applicant defined the normal working voltage is from 3.28Vdc to 4.43Vdc.

Frequency Error vs. Temperature

Temp. (°C)	n41			
	Channel Bandwidth 100 MHz			
	Low Channel		High Channel	
	Frequency (MHz)	Frequency Error (ppm)	Frequency (MHz)	Frequency Error (ppm)
-30	2546.010003	0.001	2640.000003	0.001
-20	2546.010004	0.001	2640.000003	0.001
-10	2546.010001	0.000	2640.000002	0.001
0	2546.010001	0.000	2640.000003	0.001
10	2546.009997	-0.001	2639.999997	-0.001
20	2546.009997	-0.001	2639.999998	-0.001
30	2546.009998	-0.001	2639.999999	-0.001
40	2546.009997	-0.001	2639.999998	-0.001
50	2546.009999	-0.001	2639.999999	0.000

Frequency Error vs. Voltage

Voltage (Vdc)	n66			
	Channel Bandwidth 5 MHz			
	Low Channel		High Channel	
	Frequency (MHz)	Frequency Error (ppm)	Frequency (MHz)	Frequency Error (ppm)
4.43	1712.500004	0.002	1777.500000	0.001
3.85	1712.500004	0.002	1777.500000	0.002
3.28	1712.500002	0.001	1777.500000	0.001

Note: The applicant defined the normal working voltage is from 3.28Vdc to 4.43Vdc.

Frequency Error vs. Temperature

Temp. (°C)	n66			
	Channel Bandwidth 5 MHz			
	Low Channel		High Channel	
	Frequency (MHz)	Frequency Error (ppm)	Frequency (MHz)	Frequency Error (ppm)
-30	1712.500003	0.002	1777.500000	0.002
-20	1712.500002	0.001	1777.500000	0.001
-10	1712.500002	0.001	1777.500000	0.002
0	1712.500003	0.002	1777.500000	0.001
10	1712.499997	-0.002	1777.500000	-0.001
20	1712.499998	-0.001	1777.500000	-0.001
30	1712.499997	-0.002	1777.500000	-0.001
40	1712.499998	-0.001	1777.500000	-0.001
50	1712.499998	-0.001	1777.500000	-0.001

Frequency Error vs. Voltage

Voltage (Vdc)	n66			
	Channel Bandwidth 10 MHz			
	Low Channel		High Channel	
	Frequency (MHz)	Frequency Error (ppm)	Frequency (MHz)	Frequency Error (ppm)
4.43	1715.000001	0.001	1775.000003	0.001
3.85	1715.000003	0.002	1775.000001	0.001
3.28	1715.000004	0.002	1775.000002	0.001

Note: The applicant defined the normal working voltage is from 3.28Vdc to 4.43Vdc.

Frequency Error vs. Temperature

Temp. (°C)	n66			
	Channel Bandwidth 10 MHz			
	Low Channel		High Channel	
	Frequency (MHz)	Frequency Error (ppm)	Frequency (MHz)	Frequency Error (ppm)
-30	1715.000001	0.001	1775.000003	0.002
-20	1715.000002	0.001	1775.000002	0.001
-10	1715.000002	0.001	1775.000001	0.001
0	1715.000004	0.002	1775.000002	0.001
10	1714.999999	-0.001	1774.999996	-0.002
20	1714.999997	-0.002	1774.999999	-0.001
30	1714.999997	-0.002	1774.999996	-0.002
40	1714.999996	-0.002	1774.999998	-0.001
50	1714.999998	-0.001	1774.999997	-0.002

Frequency Error vs. Voltage

Voltage (Vdc)	n66			
	Channel Bandwidth 15 MHz			
	Low Channel		High Channel	
	Frequency (MHz)	Frequency Error (ppm)	Frequency (MHz)	Frequency Error (ppm)
4.43	1717.500002	0.001	1772.500003	0.002
3.85	1717.500002	0.001	1772.500003	0.001
3.28	1717.500003	0.002	1772.500002	0.001

Note: The applicant defined the normal working voltage is from 3.28Vdc to 4.43Vdc.

Frequency Error vs. Temperature

Temp. (°C)	n66			
	Channel Bandwidth 15 MHz			
	Low Channel		High Channel	
	Frequency (MHz)	Frequency Error (ppm)	Frequency (MHz)	Frequency Error (ppm)
-30	1717.500004	0.002	1772.500004	0.002
-20	1717.500003	0.002	1772.500001	0.001
-10	1717.500002	0.001	1772.500003	0.002
0	1717.500003	0.002	1772.500003	0.001
10	1717.499998	-0.001	1772.499999	-0.001
20	1717.499998	-0.001	1772.499998	-0.001
30	1717.499997	-0.002	1772.499997	-0.002
40	1717.499999	-0.001	1772.499997	-0.002
50	1717.499996	-0.002	1772.499998	-0.001

Frequency Error vs. Voltage

Voltage (Vdc)	n66			
	Channel Bandwidth 20 MHz			
	Low Channel		High Channel	
	Frequency (MHz)	Frequency Error (ppm)	Frequency (MHz)	Frequency Error (ppm)
4.43	1720.000002	0.001	1770.000003	0.001
3.85	1720.000001	0.001	1770.000002	0.001
3.28	1720.000002	0.001	1770.000002	0.001

Note: The applicant defined the normal working voltage is from 3.28Vdc to 4.43Vdc.

Frequency Error vs. Temperature

Temp. (°C)	n66			
	Channel Bandwidth 20 MHz			
	Low Channel		High Channel	
	Frequency (MHz)	Frequency Error (ppm)	Frequency (MHz)	Frequency Error (ppm)
-30	1720.000003	0.002	1770.000002	0.001
-20	1720.000002	0.001	1770.000002	0.001
-10	1720.000003	0.002	1770.000002	0.001
0	1720.000003	0.001	1770.000001	0.001
10	1719.999997	-0.002	1769.999997	-0.002
20	1719.999996	-0.002	1769.999997	-0.002
30	1719.999998	-0.001	1769.999997	-0.002
40	1719.999998	-0.001	1769.999996	-0.002
50	1719.999997	-0.002	1769.999997	-0.002

Frequency Error vs. Voltage

Voltage (Vdc)	n66			
	Channel Bandwidth 40 MHz			
	Low Channel		High Channel	
	Frequency (MHz)	Frequency Error (ppm)	Frequency (MHz)	Frequency Error (ppm)
4.43	1730.000002	0.001	1760.000002	0.001
3.85	1730.000002	0.001	1760.000004	0.002
3.28	1730.000002	0.001	1760.000003	0.002

Note: The applicant defined the normal working voltage is from 3.28Vdc to 4.43Vdc.

Frequency Error vs. Temperature

Temp. (°C)	n66			
	Channel Bandwidth 40 MHz			
	Low Channel		High Channel	
	Frequency (MHz)	Frequency Error (ppm)	Frequency (MHz)	Frequency Error (ppm)
-30	1730.000003	0.002	1760.000003	0.002
-20	1730.000004	0.002	1760.000003	0.002
-10	1730.000003	0.002	1760.000003	0.002
0	1730.000002	0.001	1760.000003	0.002
10	1729.999998	-0.001	1759.999997	-0.002
20	1729.999997	-0.002	1759.999999	-0.001
30	1729.999998	-0.001	1759.999998	-0.001
40	1729.999998	-0.001	1759.999998	-0.001
50	1729.999999	-0.001	1759.999999	-0.001

Frequency Error vs. Voltage

Voltage (Vdc)	n71			
	Channel Bandwidth 5 MHz			
	Low Channel		High Channel	
	Frequency (MHz)	Frequency Error (ppm)	Frequency (MHz)	Frequency Error (ppm)
4.43	665.500004	0.005	695.500000	0.004
3.85	665.500003	0.004	695.500000	0.006
3.28	665.500003	0.005	695.500000	0.004

Note: The applicant defined the normal working voltage is from 3.28Vdc to 4.43Vdc.

Frequency Error vs. Temperature

Temp. (°C)	n71			
	Channel Bandwidth 5 MHz			
	Low Channel		High Channel	
	Frequency (MHz)	Frequency Error (ppm)	Frequency (MHz)	Frequency Error (ppm)
-30	665.500003	0.004	695.500000	0.002
-20	665.500001	0.002	695.500000	0.004
-10	665.500001	0.002	695.500000	0.006
0	665.500002	0.003	695.500000	0.002
10	665.499999	-0.002	695.500000	-0.002
20	665.499998	-0.004	695.500000	-0.005
30	665.499998	-0.003	695.500000	-0.003
40	665.499998	-0.002	695.500000	-0.004
50	665.499996	-0.006	695.500000	-0.004

Frequency Error vs. Voltage

Voltage (Vdc)	n71			
	Channel Bandwidth 10 MHz			
	Low Channel		High Channel	
	Frequency (MHz)	Frequency Error (ppm)	Frequency (MHz)	Frequency Error (ppm)
4.43	668.000004	0.006	693.000002	0.002
3.85	668.000001	0.002	693.000004	0.005
3.28	668.000002	0.003	693.000002	0.003

Note: The applicant defined the normal working voltage is from 3.28Vdc to 4.43Vdc.

Frequency Error vs. Temperature

Temp. (°C)	n71			
	Channel Bandwidth 10 MHz			
	Low Channel		High Channel	
	Frequency (MHz)	Frequency Error (ppm)	Frequency (MHz)	Frequency Error (ppm)
-30	668.000003	0.004	693.000003	0.005
-20	668.000002	0.003	693.000002	0.003
-10	668.000003	0.004	693.000002	0.003
0	668.000003	0.005	693.000003	0.004
10	667.999997	-0.005	692.999997	-0.004
20	667.999998	-0.003	692.999999	-0.002
30	667.999999	-0.002	692.999998	-0.003
40	667.999996	-0.006	692.999997	-0.004
50	667.999999	-0.002	692.999996	-0.005

Frequency Error vs. Voltage

Voltage (Vdc)	n71			
	Channel Bandwidth 15 MHz			
	Low Channel		High Channel	
	Frequency (MHz)	Frequency Error (ppm)	Frequency (MHz)	Frequency Error (ppm)
4.43	670.500003	0.005	690.500002	0.002
3.85	670.500002	0.004	690.500004	0.005
3.28	670.500001	0.002	690.500002	0.003

Note: The applicant defined the normal working voltage is from 3.28Vdc to 4.43Vdc.

Frequency Error vs. Temperature

Temp. (°C)	n71			
	Channel Bandwidth 15 MHz			
	Low Channel		High Channel	
	Frequency (MHz)	Frequency Error (ppm)	Frequency (MHz)	Frequency Error (ppm)
-30	670.500001	0.002	690.500002	0.003
-20	670.500001	0.002	690.500002	0.003
-10	670.500002	0.003	690.500004	0.006
0	670.500003	0.004	690.500002	0.003
10	670.499998	-0.003	690.499997	-0.005
20	670.499996	-0.006	690.499999	-0.002
30	670.499999	-0.002	690.499997	-0.004
40	670.499998	-0.003	690.499997	-0.005
50	670.499997	-0.004	690.499997	-0.004

Frequency Error vs. Voltage

Voltage (Vdc)	n71			
	Channel Bandwidth 20 MHz			
	Low Channel		High Channel	
	Frequency (MHz)	Frequency Error (ppm)	Frequency (MHz)	Frequency Error (ppm)
4.43	673.000004	0.005	688.000003	0.004
3.85	673.000004	0.006	688.000003	0.004
3.28	673.000003	0.005	688.000003	0.005

Note: The applicant defined the normal working voltage is from 3.28Vdc to 4.43Vdc.

Frequency Error vs. Temperature

Temp. (°C)	n71			
	Channel Bandwidth 20 MHz			
	Low Channel		High Channel	
	Frequency (MHz)	Frequency Error (ppm)	Frequency (MHz)	Frequency Error (ppm)
-30	673.000002	0.003	688.000003	0.005
-20	673.000003	0.005	688.000001	0.002
-10	673.000001	0.002	688.000001	0.002
0	673.000001	0.002	688.000002	0.002
10	672.999998	-0.003	687.999998	-0.003
20	672.999996	-0.006	687.999996	-0.006
30	672.999997	-0.004	687.999998	-0.002
40	672.999998	-0.003	687.999998	-0.003
50	672.999996	-0.006	687.999999	-0.002

4.4 Occupied Bandwidth Measurement

4.4.1 Limits of Occupied Bandwidth Measurement

The occupied bandwidth (OBW), that is the frequency bandwidth such that, below its lower and above its upper frequency limits, the mean powers radiated are each equal to 0.5 % of the total mean power radiated by a given emission.

4.4.2 Test Procedure

The EUT makes a call to the communication simulator. All measurements were done at low, middle and high operational frequency range. The communication simulator station system controlled a EUT to export maximum output power under transmission mode and specific channel frequency. Measurement method, please refer to section 5.4.4 of ANSI C63.26. Use OBW measurement function of Spectrum analyzer to measure 99 % occupied bandwidth.

For the 26dBc bandwidth measurement method, please refer to section 5.4.3 of ANSI C63.26.

4.4.3 Test Setup

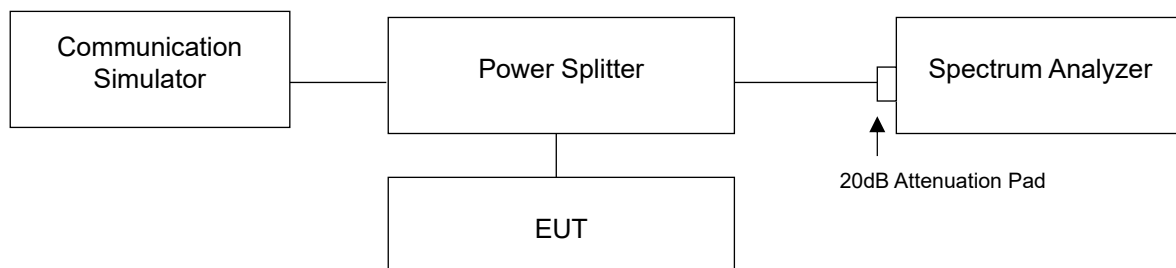

4.4.4 Test Result

Occupied Bandwidth

n41, Channel Bandwidth: 10MHz						
Channel	Frequency (MHz)	99% Occupied Bandwidth (MHz)				
		$\pi/2$ BPSK	QPSK	16QAM	64QAM	256QAM
500202	2501.01	8.56	8.56	8.56	8.57	8.56
518598	2592.99	8.56	8.56	8.56	8.57	8.56
537000	2685.00	8.56	8.56	8.56	8.57	8.56
n41, Channel Bandwidth: 15MHz						
Channel	Frequency (MHz)	99% Occupied Bandwidth (MHz)				
		$\pi/2$ BPSK	QPSK	16QAM	64QAM	256QAM
500700	2503.50	13.54	13.54	13.54	13.51	13.56
518598	2592.99	13.54	13.54	13.55	13.52	13.56
536496	2682.48	13.54	13.54	13.54	13.51	13.55
n41, Channel Bandwidth 20MHz						
Channel	Frequency (MHz)	99% Occupied Bandwidth (MHz)				
		$\pi/2$ BPSK	QPSK	16QAM	64QAM	256QAM
501204	2506.02	18.29	18.29	18.29	18.28	18.28
518598	2592.99	18.30	18.30	18.30	18.29	18.30
535998	2679.99	18.28	18.28	18.29	18.28	18.28
n41, Channel Bandwidth 40MHz						
Channel	Frequency (MHz)	99% Occupied Bandwidth (MHz)				
		$\pi/2$ BPSK	QPSK	16QAM	64QAM	256QAM
503202	2516.01	37.81	37.82	37.80	37.80	37.79
518598	2592.99	37.84	37.84	37.82	37.83	37.82
534000	2670.00	37.74	37.74	37.27	37.74	37.72
n41, Channel Bandwidth 50MHz						
Channel	Frequency (MHz)	99% Occupied Bandwidth (MHz)				
		$\pi/2$ BPSK	QPSK	16QAM	64QAM	256QAM
504204	2521.02	47.35	47.36	47.35	47.35	47.34
518598	2592.99	47.40	47.41	47.40	47.40	47.40
532998	2664.99	47.23	47.24	47.24	47.23	47.24

n41, Channel Bandwidth 60MHz						
Channel	Frequency (MHz)	99% Occupied Bandwidth (MHz)				
		$\pi/2$ BPSK	QPSK	16QAM	64QAM	256QAM
505200	2526.00	57.61	57.62	57.61	57.61	57.62
518598	2592.99	57.71	57.72	57.70	57.70	57.72
531996	2659.98	57.46	57.47	57.45	57.46	57.47
n41, Channel Bandwidth 80MHz						
Channel	Frequency (MHz)	99% Occupied Bandwidth (MHz)				
		$\pi/2$ BPSK	QPSK	16QAM	64QAM	256QAM
507204	2536.02	77.13	77.11	77.11	77.10	77.09
518598	2592.99	77.36	77.34	77.34	77.33	77.31
529998	2649.99	76.98	76.96	76.96	76.94	76.94
n41, Channel Bandwidth 90MHz						
Channel	Frequency (MHz)	99% Occupied Bandwidth (MHz)				
		$\pi/2$ BPSK	QPSK	16QAM	64QAM	256QAM
508200	2541.00	87.01	87.00	86.96	86.97	87.03
518598	2592.99	87.30	87.31	87.26	87.28	87.32
528996	2644.98	86.87	86.87	86.82	86.82	86.90
n41, Channel Bandwidth 100MHz						
Channel	Frequency (MHz)	99% Occupied Bandwidth (MHz)				
		$\pi/2$ BPSK	QPSK	16QAM	64QAM	256QAM
509202	2546.01	96.88	96.89	96.89	96.87	96.86
518598	2592.99	97.24	97.25	97.26	97.23	97.22
528000	2640.00	96.75	96.76	96.77	96.73	96.72

Spectrum Plot of Worst Value

10MHz / 64QAM

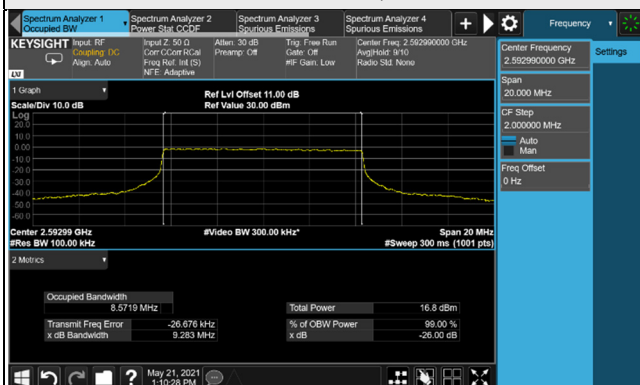

15MHz / 256QAM

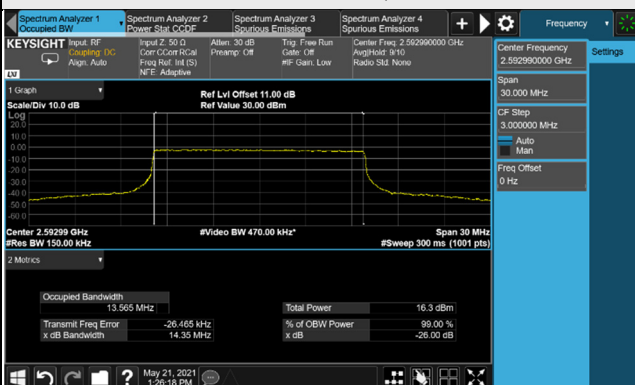

20MHz / 16QAM

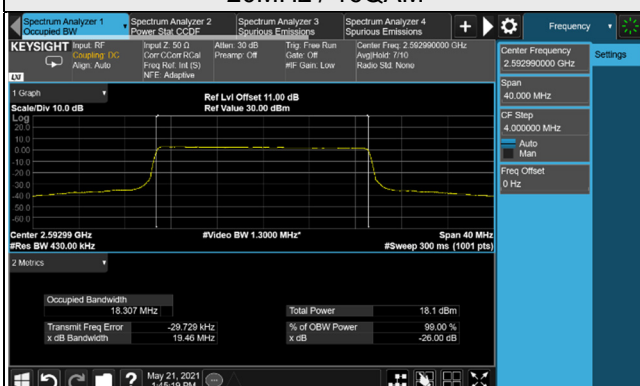

40MHz / QPSK

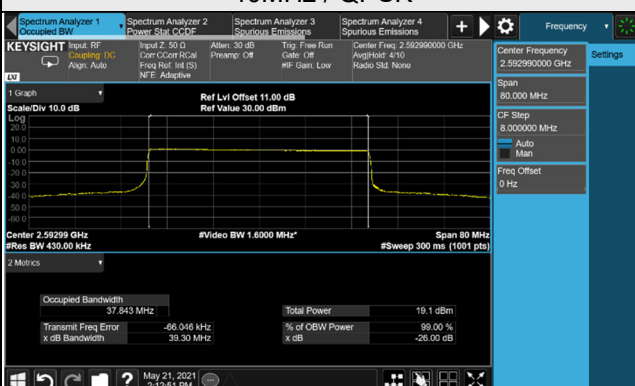

50MHz / QPSK

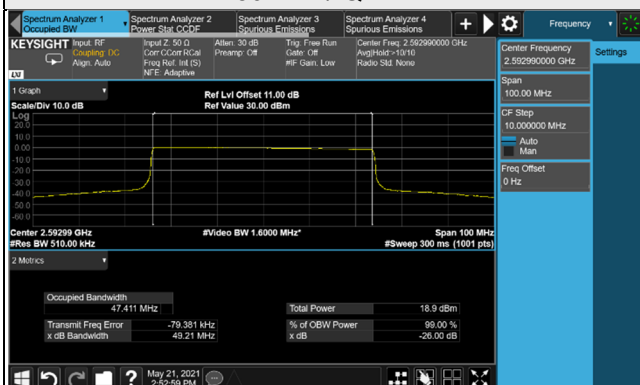

60MHz / QPSK

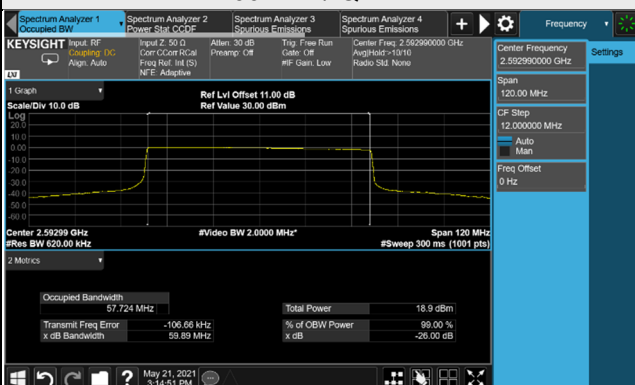

80MHz / $\pi/2$ BPSK

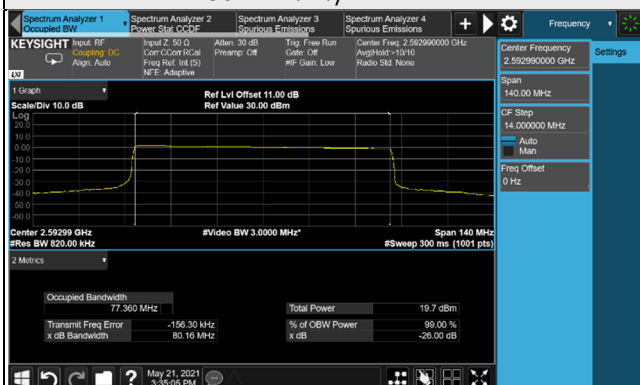

90MHz / 256QAM

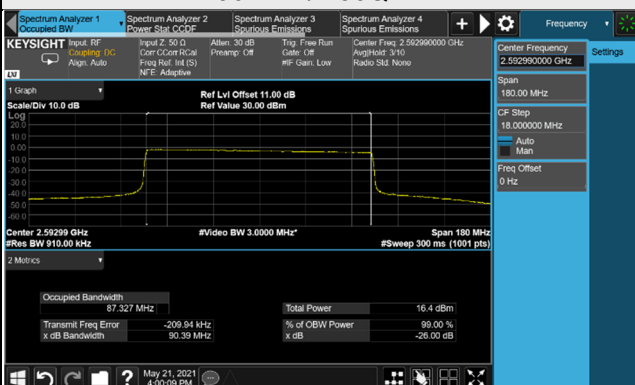

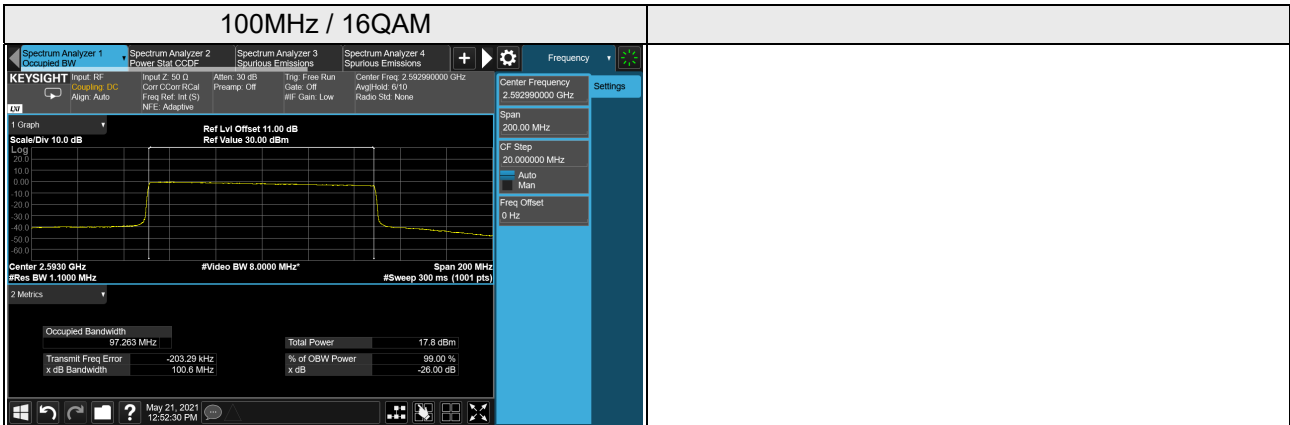

n66, Channel Bandwidth 5MHz						
Channel	Frequency (MHz)	99% Occupied Bandwidth (MHz)				
		$\pi/2$ BPSK	QPSK	16QAM	64QAM	256QAM
342500	1712.5	4.46	4.46	4.46	4.46	4.46
349000	1745.0	4.46	4.46	4.46	4.45	4.46
355500	1777.5	4.46	4.46	4.46	4.46	4.46
n66, Channel Bandwidth 10MHz						
Channel	Frequency (MHz)	99% Occupied Bandwidth (MHz)				
		$\pi/2$ BPSK	QPSK	16QAM	64QAM	256QAM
343000	1715.0	9.28	9.27	9.28	9.27	9.26
349000	1745.0	9.28	9.27	9.28	9.27	9.26
355000	1775.0	9.28	9.27	9.28	9.27	9.26
n66, Channel Bandwidth 15MHz						
Channel	Frequency (MHz)	99% Occupied Bandwidth (MHz)				
		$\pi/2$ BPSK	QPSK	16QAM	64QAM	256QAM
343500	1717.5	14.08	14.08	14.07	14.08	14.08
349000	1745.0	14.08	14.08	14.07	14.08	14.08
354500	1772.5	14.08	14.08	14.07	14.08	14.07
n66, Channel Bandwidth 20MHz						
Channel	Frequency (MHz)	99% Occupied Bandwidth (MHz)				
		$\pi/2$ BPSK	QPSK	16QAM	64QAM	256QAM
344000	1720.0	18.91	18.91	18.90	18.90	18.92
349000	1745.0	18.92	18.91	18.91	18.91	18.92
354000	1770.0	18.91	18.90	18.90	18.90	18.90
n66, Channel Bandwidth 40MHz						
Channel	Frequency (MHz)	99% Occupied Bandwidth (MHz)				
		$\pi/2$ BPSK	QPSK	16QAM	64QAM	256QAM
346000	1730.0	38.56	38.52	38.51	38.51	38.52
349000	1745.0	38.61	38.58	38.58	38.58	38.57
352000	1760.0	38.57	38.55	38.54	38.56	38.56

Spectrum Plot of Worst Value

5MHz / 256QAM

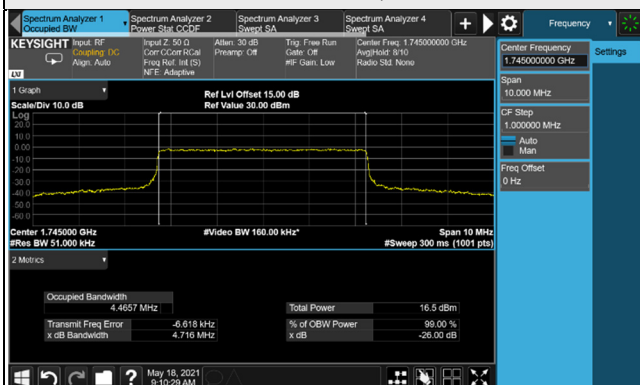

10MHz / $\pi/2$ BPSK

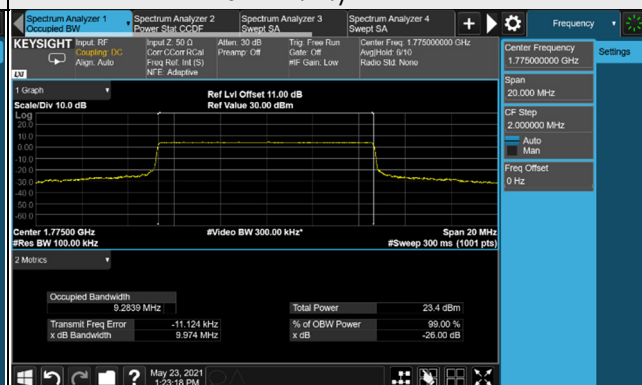

15MHz / $\pi/2$ BPSK

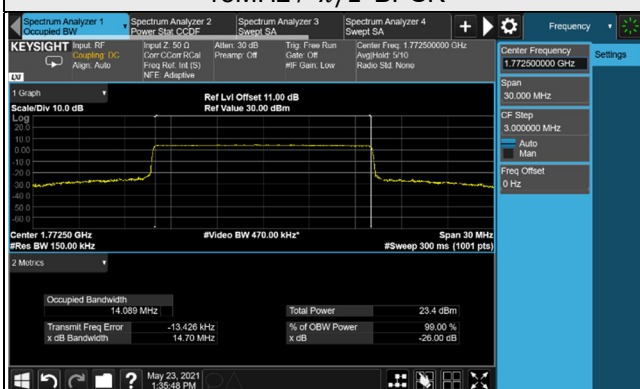

20MHz / $\pi/2$ BPSK

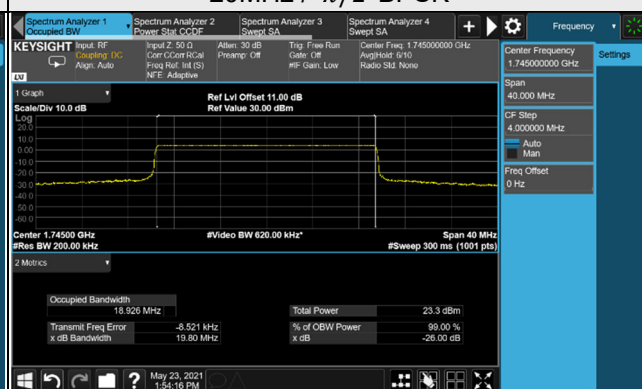

40MHz / $\pi/2$ BPSK

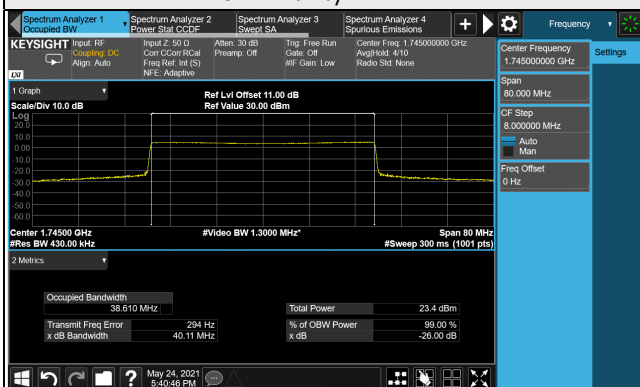

n71, Channel Bandwidth 5MHz						
Channel	Frequency (MHz)	99% Occupied Bandwidth (MHz)				
		$\pi/2$ BPSK	QPSK	16QAM	64QAM	256QAM
133100	665.5	4.46	4.46	4.46	4.46	4.46
136100	680.5	4.46	4.46	4.46	4.46	4.46
139100	695.5	4.46	4.45	4.46	4.46	4.46
n71, Channel Bandwidth 10MHz						
Channel	Frequency (MHz)	99% Occupied Bandwidth (MHz)				
		$\pi/2$ BPSK	QPSK	16QAM	64QAM	256QAM
133600	668.0	9.27	9.26	9.27	9.26	9.25
136100	680.5	9.27	9.27	9.28	9.27	9.26
138600	693.0	9.27	9.27	9.27	9.27	9.26
n71 Channel Bandwidth 15MHz						
Channel	Frequency (MHz)	99% Occupied Bandwidth (MHz)				
		$\pi/2$ BPSK	QPSK	16QAM	64QAM	256QAM
134100	670.5	14.05	14.05	14.04	14.04	14.04
136100	680.5	14.07	14.06	14.06	14.07	14.06
138100	690.5	14.07	14.07	14.06	14.07	14.06
n71, Channel Bandwidth 20MHz						
Channel	Frequency (MHz)	99% Occupied Bandwidth (MHz)				
		$\pi/2$ BPSK	QPSK	16QAM	64QAM	256QAM
134600	673.0	18.87	18.87	18.86	18.86	18.87
136100	680.5	18.91	18.91	18.91	18.91	18.91
137600	688.0	18.89	18.89	18.89	18.89	18.90

Spectrum Plot of Worst Value

5MHz / $\pi/2$ BPSK

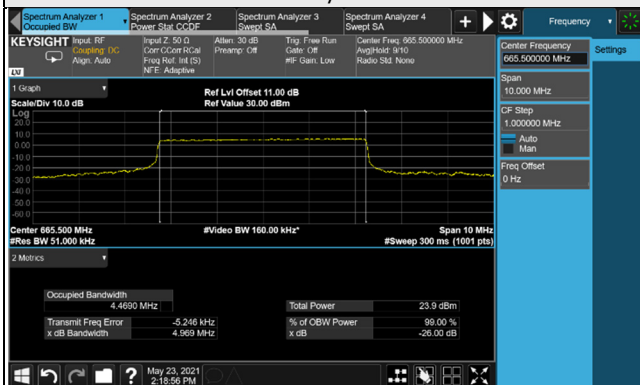

10MHz / 16QAM

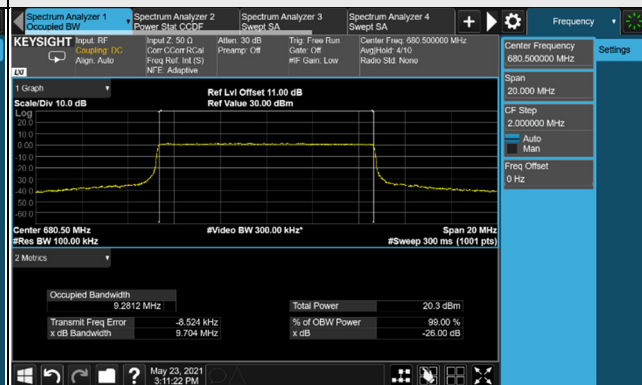

15MHz / 64QAM

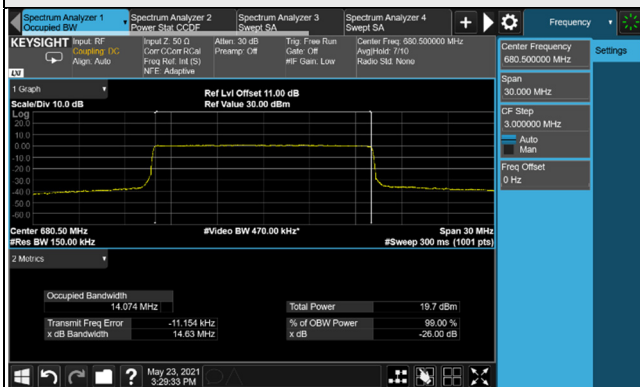

20MHz / $\pi/2$ BPSK

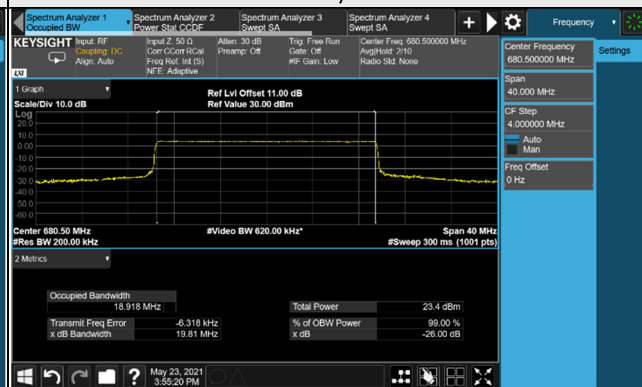

26dB Bandwidth

n41, Channel Bandwidth: 10MHz						
Channel	Frequency (MHz)	26dB Bandwidth (MHz)				
		$\pi/2$ BPSK	QPSK	16QAM	64QAM	256QAM
500202	2501.01	9.22	9.37	9.23	9.26	9.24
518598	2592.99	9.20	9.38	9.23	9.28	9.25
537000	2685.00	9.17	9.40	9.23	9.26	9.23
n41, Channel Bandwidth: 15MHz						
Channel	Frequency (MHz)	26dB Bandwidth (MHz)				
		$\pi/2$ BPSK	QPSK	16QAM	64QAM	256QAM
500700	2503.50	14.26	14.39	14.45	14.16	14.38
518598	2592.99	14.29	14.36	14.50	14.18	14.35
536496	2682.48	14.28	14.38	14.47	14.17	14.35
n41, Channel Bandwidth 20MHz						
Channel	Frequency (MHz)	26dB Bandwidth (MHz)				
		$\pi/2$ BPSK	QPSK	16QAM	64QAM	256QAM
501204	2506.02	19.49	19.46	19.47	19.41	19.42
518598	2592.99	19.45	19.44	19.46	19.42	19.40
535998	2679.99	19.41	19.41	19.43	19.38	19.37
n41, Channel Bandwidth 40MHz						
Channel	Frequency (MHz)	26dB Bandwidth (MHz)				
		$\pi/2$ BPSK	QPSK	16QAM	64QAM	256QAM
503202	2516.01	39.41	39.32	39.43	39.41	39.29
518598	2592.99	39.32	39.30	39.32	39.30	39.25
534000	2670.00	39.30	39.27	39.25	39.25	39.20
n41, Channel Bandwidth 50MHz						
Channel	Frequency (MHz)	26dB Bandwidth (MHz)				
		$\pi/2$ BPSK	QPSK	16QAM	64QAM	256QAM
504204	2521.02	49.22	49.20	49.16	49.18	49.16
518598	2592.99	49.24	49.21	49.17	49.19	49.18
532998	2664.99	49.17	49.16	49.11	49.13	49.11

n41, Channel Bandwidth 60MHz						
Channel	Frequency (MHz)	26dB Bandwidth (MHz)				
		$\pi/2$ BPSK	QPSK	16QAM	64QAM	256QAM
505200	2526.00	59.85	59.84	59.81	59.82	59.85
518598	2592.99	59.86	59.89	59.85	59.85	59.86
531996	2659.98	59.80	59.81	59.79	59.80	59.80
n41, Channel Bandwidth 80MHz						
Channel	Frequency (MHz)	26dB Bandwidth (MHz)				
		$\pi/2$ BPSK	QPSK	16QAM	64QAM	256QAM
507204	2536.02	80.12	80.03	80.04	80.10	80.03
518598	2592.99	80.16	80.07	80.12	80.15	80.11
529998	2649.99	80.09	79.98	80.03	80.06	79.99
n41, Channel Bandwidth 90MHz						
Channel	Frequency (MHz)	26dB Bandwidth (MHz)				
		$\pi/2$ BPSK	QPSK	16QAM	64QAM	256QAM
508200	2541.00	90.34	90.38	90.30	90.29	90.30
518598	2592.99	90.40	90.44	90.38	90.39	90.39
528996	2644.98	90.32	90.35	90.28	90.28	90.31
n41, Channel Bandwidth 100MHz						
Channel	Frequency (MHz)	26dB Bandwidth (MHz)				
		$\pi/2$ BPSK	QPSK	16QAM	64QAM	256QAM
509202	2546.01	100.60	100.60	100.50	100.50	100.50
518598	2592.99	100.60	100.60	100.60	100.60	100.60
528000	2640.00	100.60	100.60	100.50	100.60	100.50

Spectrum Plot of Worst Value

10MHz / QPSK

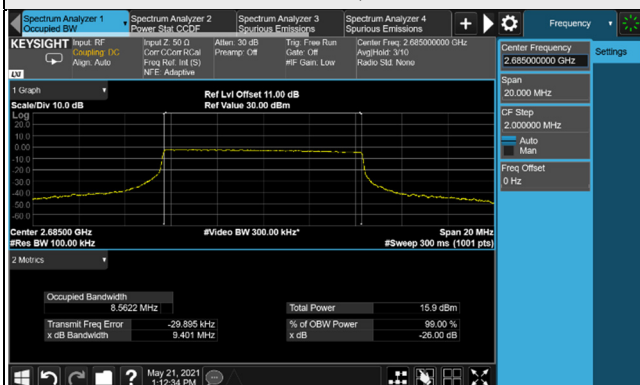

15MHz / 16QAM

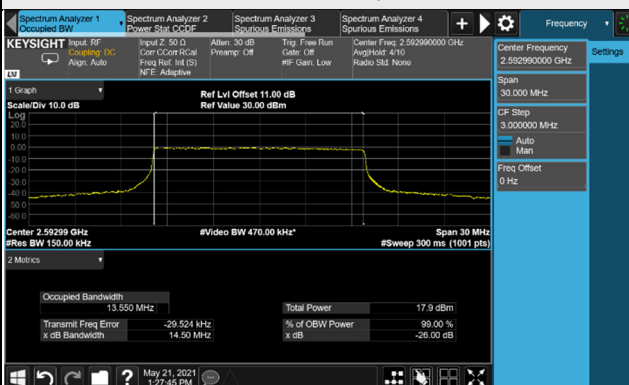

20MHz / $\pi/2$ BPSK

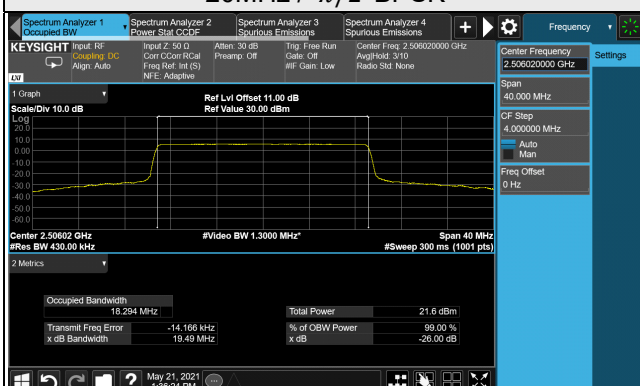

40MHz / 16QAM

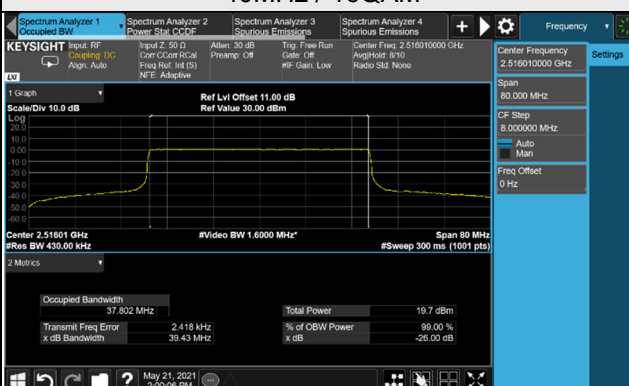

50MHz / $\pi/2$ BPSK

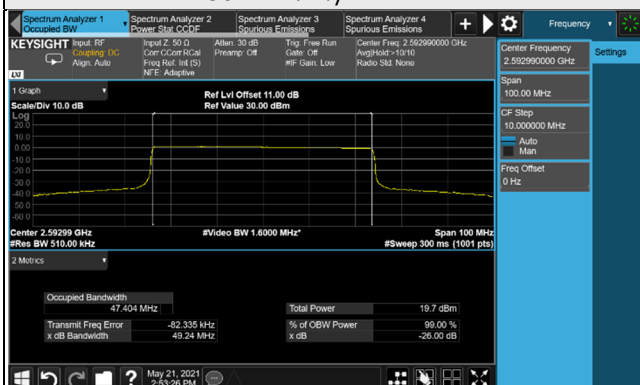

60MHz / QPSK

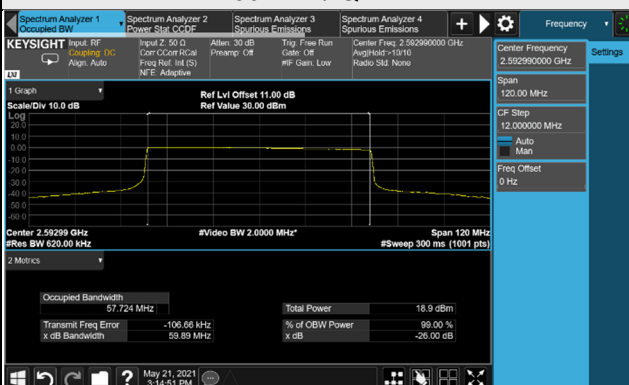

80MHz / $\pi/2$ BPSK

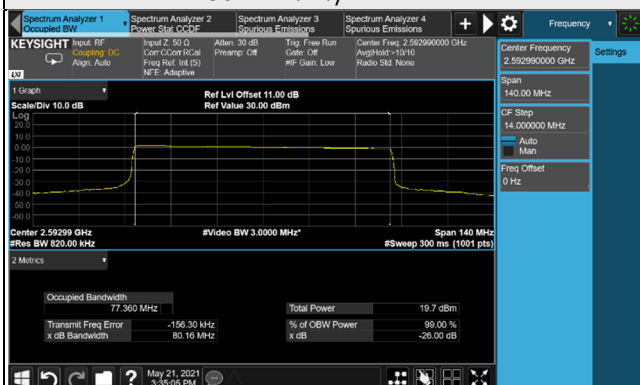

90MHz / QPSK

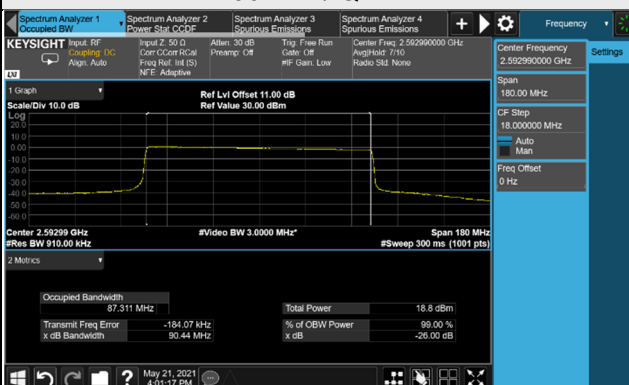

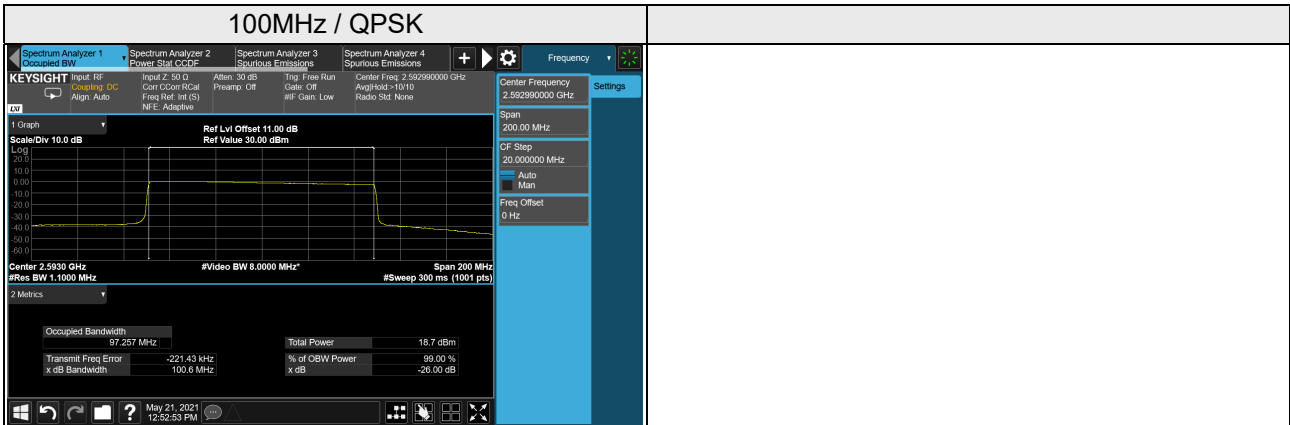

n66, Channel Bandwidth 5MHz						
Channel	Frequency (MHz)	26dB Bandwidth (MHz)				
		$\pi/2$ BPSK	QPSK	16QAM	64QAM	256QAM
342500	1712.5	4.87	4.74	4.73	4.72	4.74
349000	1745.0	4.90	4.74	4.75	4.71	4.71
355500	1777.5	4.88	4.70	4.70	4.67	4.69
n66, Channel Bandwidth 10MHz						
Channel	Frequency (MHz)	26dB Bandwidth (MHz)				
		$\pi/2$ BPSK	QPSK	16QAM	64QAM	256QAM
343000	1715.0	9.79	9.71	9.69	9.66	9.75
349000	1745.0	9.89	9.70	9.71	9.65	9.73
355000	1775.0	9.97	9.70	9.70	9.64	9.75
n66, Channel Bandwidth 15MHz						
Channel	Frequency (MHz)	26dB Bandwidth (MHz)				
		$\pi/2$ BPSK	QPSK	16QAM	64QAM	256QAM
343500	1717.5	14.66	14.63	14.62	14.64	14.66
349000	1745.0	14.68	14.63	14.64	14.64	14.66
354500	1772.5	14.70	14.62	14.62	14.63	14.64
n66, Channel Bandwidth 20MHz						
Channel	Frequency (MHz)	26dB Bandwidth (MHz)				
		$\pi/2$ BPSK	QPSK	16QAM	64QAM	256QAM
344000	1720.0	19.73	19.64	19.60	19.66	19.64
349000	1745.0	19.80	19.64	19.63	19.69	19.66
354000	1770.0	19.83	19.66	19.61	19.61	19.63
n66, Channel Bandwidth 40MHz						
Channel	Frequency (MHz)	26dB Bandwidth (MHz)				
		$\pi/2$ BPSK	QPSK	16QAM	64QAM	256QAM
346000	1730.0	40.27	39.96	39.95	39.95	39.93
349000	1745.0	40.11	39.96	39.98	39.95	39.95
352000	1760.0	40.08	39.96	39.98	39.95	39.94