

FCC Test Report (Part 27 – CA mode: LTE Band 41C)

Report No.: RFBCKT-WTW-P21031102-7

FCC ID: HFSQTAD53

Test Model: QTAD53

Received Date: Mar. 31, 2021

Test Date: Apr. 28 ~ May 25, 2021

Issued Date: May 25, 2021

Applicant: QUANTA COMPUTER INC

Address: No. 211, Wenhua 2nd Rd., Guishan Dist., Taoyuan City 33377, Taiwan

Issued By: Bureau Veritas Consumer Products Services (H.K.) Ltd., Taoyuan Branch
Lin Kou Laboratories

Lab Address: No. 47-2, 14th Ling, Chia Pau Vil., Lin Kou Dist., New Taipei City, Taiwan

Test Location: No. 19, Hwa Ya 2nd Rd., Wen Hwa Vil., Kwei Shan Dist., Taoyuan City
33383, TAIWAN

**FCC Registration /
Designation Number:** 788550 / TW0003



This report is for your exclusive use. Any copying or replication of this report to or for any other person or entity, or use of our name or trademark, is permitted only with our prior written permission. This report sets forth our findings solely with respect to the test samples identified herein. The results set forth in this report are not indicative or representative of the quality or characteristics of the lot from which a test sample was taken or any similar or identical product unless specifically and expressly noted. Our report includes all of the tests requested by you and the results thereof based upon the information that you provided to us. You have 60 days from date of issuance of this report to notify us of any material error or omission caused by our negligence, provided, however, that such notice shall be in writing and shall specifically address the issue you wish to raise. A failure to raise such issue within the prescribed time shall constitute your unqualified acceptance of the completeness of this report, the tests conducted and the correctness of the report contents. Unless specifically mentioned, the uncertainty of measurement has been explicitly taken into account to declare the compliance or non-compliance to the specification.

Table of Contents

Release Control Record	3
1 Certificate of Conformity	4
2 Summary of Test Results	5
2.1 Measurement Uncertainty.....	5
2.2 Test Site and Instruments.....	6
3 General Information	7
3.1 General Description of EUT.....	7
3.2 Configuration of System under Test.....	9
3.2.1 Description of Support Units.....	9
3.3 Test Mode Applicability and Tested Channel Detail.....	10
3.4 EUT Operating Conditions.....	12
3.5 General Description of Applied Standards and References.....	12
4 Test Types and Results	13
4.1 Output Power Measurement.....	13
4.1.1 Limits of Output Power Measurement.....	13
4.1.2 Test Procedures.....	13
4.1.3 Test Setup.....	13
4.1.4 Test Results.....	14
4.2 Frequency Stability Measurement.....	16
4.2.1 Limits of Frequency Stability Measurement.....	16
4.2.2 Test Procedure.....	16
4.2.3 Test Setup.....	16
4.2.4 Test Results.....	17
4.3 Occupied Bandwidth Measurement.....	18
4.3.1 Limits of Occupied Bandwidth Measurement.....	18
4.3.2 Test Procedure.....	18
4.3.3 Test Setup.....	18
4.3.4 Test Result.....	19
4.4 Channel Edge Measurement.....	20
4.4.1 Limits of Band Edge Measurement.....	20
4.4.2 Test Setup.....	20
4.4.3 Test Procedures.....	20
4.4.4 Test Results.....	21
4.5 Peak to Average Ratio.....	22
4.5.1 Limits of Peak to Average Ratio Measurement.....	22
4.5.2 Test Setup.....	22
4.5.3 Test Procedures.....	22
4.5.4 Test Results.....	23
4.6 Conducted Spurious Emissions.....	24
4.6.1 Limits of Conducted Spurious Emissions Measurement.....	24
4.6.2 Test Setup.....	24
4.6.3 Test Procedure.....	24
4.6.4 Test Results.....	25
4.7 Radiated Emission Measurement.....	28
4.7.1 Limits of Radiated Emission Measurement.....	28
4.7.2 Test Procedure.....	28
4.7.3 Deviation from Test Standard.....	28
4.7.4 Test Setup.....	29
4.7.5 Test Results.....	30
5 Pictures of Test Arrangements	35
Appendix – Information of the Testing Laboratories	36

Release Control Record

Issue No.	Description	Date Issued
RFBCKT-WTW-P21031102-7	Original release	May 25, 2021

1 Certificate of Conformity

Product: 5G Hotspot
Brand: T-Mobile
Test Model: QTAD53
Sample Status: Engineering sample
Applicant: QUANTA COMPUTER INC
Test Date: Apr. 28 ~ May 25, 2021
Standards: FCC Part 27, Subpart C, M

The above equipment has been tested by **Bureau Veritas Consumer Products Services (H.K.) Ltd., Taoyuan Branch**, and found compliance with the requirement of the above standards. The test record, data evaluation & Equipment Under Test (EUT) configurations represented herein are true and accurate accounts of the measurements of the sample's RF characteristics under the conditions specified in this report.

Prepared by : Celine Chou , **Date:** May 25, 2021
Celine Chou / Senior Specialist

Approved by : Bruce Chen , **Date:** May 25, 2021
Bruce Chen / Senior Project Engineer

2 Summary of Test Results

Applied Standard: FCC Part 27 & Part 2			
FCC Clause	Test Item	Result	Remarks
2.1046 27.50 (h)(2)	Equivalent Isotropically Radiated Power	Pass	Meet the requirement of limit.
2.1047	Modulation Characteristics	Pass	Refer to Note 2
---	Peak To Average Ratio	Pass	Meet the requirement of limit.
2.1055 27.54	Frequency Stability Stay with the authorized bands of operation	Pass	Meet the requirement of limit.
2.1049	Emission Bandwidth	Pass	Meet the requirement of limit.
2.1051 27.53 (m)(4)(6)	Band Edge Measurements	Pass	Meet the requirement of limit.
2.1051 27.53 (m)(4)(6)	Conducted Spurious Emissions	Pass	Meet the requirement of limit.
2.1053 27.53 (m)(4)(6)	Radiated Spurious Emissions	Pass	Meet the requirement of limit. Minimum passing margin is -23.80dB at 51.09MHz.

Note:

- Determining compliance based on the results of the compliance measurement, not taking into account measurement instrumentation uncertainty.
- LTE CA mode is similar to digital modulation in LTE single frequency band, so please refer to BV CPS report no.: RFBCKT-WTW-P21031102-5 for the modulation characteristics data of CA mode.

2.1 Measurement Uncertainty

Where relevant, the following measurement uncertainty levels have been estimated for tests performed on the EUT as specified in CISPR 16-4-2:

Measurement	Frequency	Expanded Uncertainty (k=2) (±)
Radiated Emissions up to 1 GHz	9kHz ~ 30MHz	3.04 dB
	30MHz ~ 200MHz	3.86 dB
	200MHz ~ 1000MHz	3.87 dB
Radiated Emissions above 1 GHz	1GHz ~ 18GHz	2.29 dB
	18GHz ~ 40GHz	2.29 dB

2.2 Test Site and Instruments

Description & Manufacturer	Model No.	Serial No.	Cal. Date	Cal. Due
Test Receiver ROHDE & SCHWARZ	ESR3	102579	Jul. 07, 2020	Jul. 06, 2021
Spectrum Analyzer ROHDE & SCHWARZ	FSP40	100269	Jun. 09, 2020	Jun. 08, 2021
MXG Vector signal generator Agilent	N5182B	MY53050430	Nov. 25, 2020	Nov. 24, 2021
Radio Communication Analyzer Anritsu	MT8821C	6261806803	Jan. 22, 2021	Jan. 21, 2022
BILOG Antenna SCHWARZBECK	VULB9168	9168-171	Nov. 04, 2020	Nov. 03, 2021
HORN Antenna SCHWARZBECK	9120D	209	Nov. 22, 2020	Nov. 21, 2021
HORN Antenna SCHWARZBECK	BBHA 9170	BBHA9170241	Nov. 22, 2020	Nov. 21, 2021
Loop Antenna TESEQ	HLA 6121	45745	Jul. 06, 2020	Jul. 05, 2021
Preamplifier Agilent (Below 1GHz)	8447D	2944A10738	Aug. 16, 2020	Aug. 15, 2021
Preamplifier Agilent (Above 1GHz)	8449B	3008A02465	Mar. 22, 2021	Mar. 21, 2022
RF Coaxial Cable WOKEN With 5dB Pad	8D-FB	Cable-CH3-01	Aug. 16, 2020	Aug. 15, 2021
RF signal cable HUBER+SUHNER	SUCOFLEX 104	Cable-CH3-03 (223653/4)	Aug. 16, 2020	Aug. 15, 2021
RF signal cable HUBER+SUHNER& EMCI	SUCOFLEX 104&EMC104-SM-S M-8000	Cable-CH3-03 (309224+170907)	Aug. 16, 2020	Aug. 15, 2021
Software BV ADT	ADT_Radiated_ V7.6.15.9.5	NA	NA	NA
Antenna Tower inn-co GmbH	MA 4000	013303	NA	NA
Antenna Tower Controller BV ADT	AT100	AT93021702	NA	NA
Turn Table BV ADT	TT100	TT93021702	NA	NA
Turn Table Controller BV ADT	SC100	SC93021702	NA	NA
Boresight Antenna Fixture	FBA-01	FBA-SIP01	NA	NA
Standard Temperature And Humidity Chamber GIANT FORCE	GTH-120-40-CP-AR	MAA1306-019	Sep. 10, 2020	Sep. 09, 2021
JFW 20dB attenuation	50HF-020-SMA	NA	NA	NA
True RMS Clamp Meter Fluke	325	31130711WS	Jun 06, 2020	Jun 05, 2021
DC power supply Keysight	U8002A	MY56330015	NA	NA

Note: 1. The calibration interval of the above test instruments is 12 months and the calibrations are traceable to NML/ROC and NIST/USA.
2. The test was performed in HwaYa Chamber 3.

3 General Information

3.1 General Description of EUT

Product	5G Hotspot				
Brand	T-Mobile				
Test Model	QTAD53				
Sample Status	Engineering sample				
Power Supply Rating	5Vdc / 9Vdc / 12Vdc (Adapter) 3.85Vdc (Battery)				
Modulation Type	QPSK, 16QAM, 64QAM, 256QAM				
Operating Frequency	LTE Band 41C (20MHz + 20MHz)	2506.0MHz ~ 2680.0MHz			
Max. EIRP Power		QPSK	16QAM	64QAM	256QAM
	LTE Band 41C (20MHz + 20MHz)	283.792mW (24.53dBm)	225.424mW (23.53dBm)	179.473mW (22.54dBm)	90.157mW (19.55dBm)
Emission Designator		QPSK	16QAM	64QAM	256QAM
	LTE Band 41C (20MHz + 20MHz)	37M5G7D	37M5D7W	37M5D7W	37M5D7W
Antenna Type	Refer to Note as below				
Antenna Connector	Refer to Note as below				
Accessory Device	Refer to Note as below				
Cable Supplied	Refer to Note as below				

Note:

1. The EUT contains following accessory devices.

Product	Brand	Model	Description
Adapter 1	TEN PAO INTERNATIONAL LTD.	S018BYU1200150	I/P: 100-240Vac, 50/60Hz, 600mA O/P: 5Vdc/9Vdc/12Vdc=3A/2A/1.5A
Adapter 2	Aohai Technology Co., Ltd	A138A-120150U-US2	I/P: 100-240V~50/60Hz, 0.5A O/P: 5Vdc, 2.5A/9Vdc, 2A/12Vdc, 1.5A
USB Cable	Electronics Taiwan Ltd.	DDEMU110079	0.95m shielded USB cable without core
Battery	VEKEN	141033	3.85Vdc, 6240mAh, 24.02Wh

2. There are two sources for EUT's main board and memory. Only the supplier is different and the rest of the specifications are the same.

Sample	Item	Brand	Model
A	PCB - Main	Unimicron Technology Corporation.	12VPL4024C for MODEM board, 06VPL4028C for Main board
	Memory - Main	Nanya Technology Corporation	NM4888KSPAXAI-3E
B	PCB -Second	AKM Meadville	HI12C124A for MODEM board, HI06T221A for Main board
	Memory - Second	Jeju Semiconductor Corp.	JSFDDQ5QHAFGD-405

* After pre-tested, sample A was the worse and chosen for final test.

3. The following antennas were provided to the EUT.

LTE Band														
Ant. No.	Type	Connector	Gain (dBi)											
			B2	B4	B5	B7	B12	B13	B25	B26	B38	B41	B66	B71
0	PIFA	MUR	1.23871	3.16163	0.345671	1.15435	0.154297	-3.23099	1.23871	0.702007	0.371642	1.15435	3.16163	0.426023
1	PIFA	IPEX	-	-	-	-	-	-	-	-	-	-	-	-
2	PIFA	IPEX	0.861738	0.805343	-	-	-	-	-	-	-	-	0.805343	-
3	PIFA	MUR	-	-	-	-	-	-	-	-	-	-	-	-
4	PIFA	IPEX	-	-	-	-	-	-	-	-	-	-	-	-

* The above Antenna information is declared by manufacturer and for more detailed features description, please refer to the manufacturer's specifications, the laboratory shall not be held responsible.

4. For CA mode configuration, please consult the manufacturer to declare the test mode.

5. The EUT support the following CA Configuration.

Band Configuration
41C

6. E-UTRA CA configuration / Bandwidth combination set.

E-UTRA CA configuration / Bandwidth combination set					
E-UTRA CA configuration	Uplink CA configurations	Component carriers in order of increasing carrier frequency		Maximum aggregated bandwidth [MHz]	Bandwidth combination set
		Channel bandwidths for carrier [MHz]	Channel bandwidths for carrier [MHz]		
CA_41C	CA_41C	10	20	40	0
		15	15, 20		
		20	10, 15, 20		
		5, 10	20	40	1
		15	15, 20		
		20	5, 10, 15, 20		
		10	15, 20	40	2
		15	10, 15, 20		
		20	10, 15, 20		
		10	20	40	3
		20	20		

*41C is continuous CA and maximum combination is 20M+20M.

3.2 Configuration of System under Test

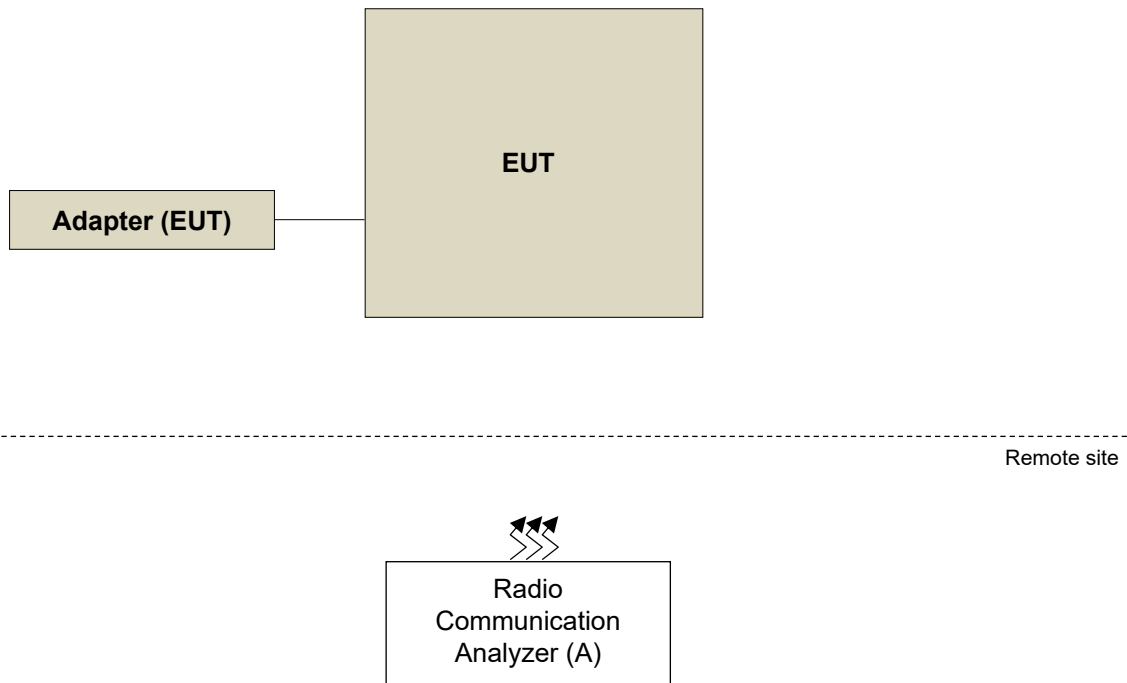

3.2.1 Description of Support Units

The EUT has been tested as an independent unit together with other necessary accessories or support units. The following support units or accessories were used to form a representative test configuration during the tests.

ID	Product	Brand	Model No.	Serial No.	FCC ID	Remarks
A.	Radio Communication Analyzer	Anritsu	MT8821C	6261806803	NA	-

Note:

1. All power cords of the above support units are non-shielded (1.8m).
2. Item A acted as a communication partner to transfer data.

3.3 Test Mode Applicability and Tested Channel Detail

Pre-Scan has been conducted to determine the worst-case mode from all possible combinations between available modulations, data rates, XYZ axis and antenna ports. The worst case was found when positioned as the table below. Following channel(s) was (were) selected for the final test as listed below:

Band	Radiated Emission
LTE Band 41C	X-plane

LTE Band 41 (CA 41C)

EUT Configure Mode	Test item	Available channel	Tested channel	Channel Bandwidth	Modulation	Mode
-	EIRP	39750 to 41292 39948 to 41490	39750 (2506.0MHz) + 39948 (2525.8MHz), 40521 (2583.1MHz) + 40719 (2602.9MHz), 41292 (2660.2MHz) + 41490 (2680.0MHz)	20MHz + 20MHz	QPSK / 16QAM / 64QAM / 256QAM	1 RB / 0 RB Offset 1 RB / 99 RB Offset
-	Frequency Stability	39750 to 41292 39948 to 41490	41292 (2660.2MHz)+ 41490 (2680.0MHz)	20MHz + 20MHz	QPSK	100 RB / 0 RB Offset
-	Occupied Bandwidth	39750 to 41292 39948 to 41490	39750 (2506.0MHz) + 39948 (2525.8MHz), 40521 (2583.1MHz) + 40719 (2602.9MHz), 41292 (2660.2MHz) + 41490 (2680.0MHz)	20MHz + 20MHz	QPSK / 16QAM / 64QAM / 256QAM	1 RB / 0 RB Offset 1 RB / 99 RB Offset
-	Emission Mask	39750 to 41292 39948 to 41490	39750 (2506.0MHz) + 39948 (2525.8MHz), 40521 (2583.1MHz) + 40719 (2602.9MHz), 41292 (2660.2MHz) + 41490 (2680.0MHz)	20MHz + 20MHz	QPSK	1 RB / 0 RB Offset 1 RB / 99 RB Offset 100 RB / 0 RB Offset
-	Peak to Average Ratio	39750 to 41292 39948 to 41490	39750 (2506.0MHz) + 39948 (2525.8MHz), 40521 (2583.1MHz) + 40719 (2602.9MHz), 41292 (2660.2MHz) + 41490 (2680.0MHz)	20MHz + 20MHz	QPSK / 16QAM / 64QAM / 256QAM	1 RB / 0 RB Offset 1 RB / 99 RB Offset
-	Conducted Emission	39750 to 41292 39948 to 41490	39750 (2506.0MHz) + 39948 (2525.8MHz), 40521 (2583.1MHz) + 40719 (2602.9MHz), 41292 (2660.2MHz) + 41490 (2680.0MHz)	20MHz + 20MHz	QPSK	1 RB / 0 RB Offset 1 RB / 99 RB Offset

EUT Configure Mode	Test item	Available channel	Tested channel	Channel Bandwidth	Modulation	Mode
-	Radiated Emission Below 1GHz	39750 to 41292 39948 to 41490	40521 (2583.1MHz) + 40719 (2602.9MHz)	20MHz + 20MHz	QPSK	1 RB / 0 RB Offset 1 RB / 99 RB Offset
-	Radiated Emission Above 1GHz	39750 to 41292 39948 to 41490	39750 (2506.0MHz) + 39948 (2525.8MHz), 40521 (2583.1MHz) + 40719 (2602.9MHz), 41292 (2660.2MHz) + 41490 (2680.0MHz)	20MHz + 20MHz	QPSK	1 RB / 0 RB Offset 1 RB / 99 RB Offset

Note:

1. This device was tested under all bandwidths, RB configurations and modulations. The worst case was found in QPSK modulation.
2. LTE CA mode is similar to digital modulation in LTE single frequency band, so please refer to BV CPS report no.: RFBCKT-WTW-P21031102-5 for the modulation characteristics data of CA mode.

Test Condition:

Test Item	Environmental Conditions	Input Power	Tested By
EIRP	25deg. C, 60%RH	120Vac, 60Hz	James Yang
Frequency Stability	25deg. C, 60%RH	3.85Vdc	James Yang
Occupied Bandwidth	25deg. C, 60%RH	120Vac, 60Hz	James Yang
Band Edge	25deg. C, 60%RH	120Vac, 60Hz	James Yang
Peak To Average Ratio	25deg. C, 60%RH	120Vac, 60Hz	James Yang
Conducted Emission	25deg. C, 60%RH	120Vac, 60Hz	James Yang
Radiated Emission	23deg. C, 66%RH	120Vac, 60Hz	Titan Hsu

3.4 EUT Operating Conditions

The EUT makes a call to the communication simulator. The communication simulator station system controlled a EUT to export maximum output power under transmission mode and specific channel frequency

3.5 General Description of Applied Standards and References

The EUT is a RF Product. According to the specifications of the manufacturer, it must comply with the requirements of the following standards and References:

Test Standard:

FCC 47 CFR Part 2

FCC 47 CFR Part 27

ANSI/TIA/EIA-603-E 2016

ANSI 63.26-2015

All test items have been performed and recorded as per the above standards.

References Test Guidance:

KDB 971168 D01 Power Meas License Digital Systems v03r01

All test items have been performed as a reference to the above KDB test guidance.

4 Test Types and Results

4.1 Output Power Measurement

4.1.1 Limits of Output Power Measurement

Mobile stations are limited to 2.0 watts EIRP. All user stations are limited to 2.0 watts transmitter output power.

4.1.2 Test Procedures

Conducted Power Measurement:

The EUT was set up for the maximum power with LTE link data modulation and link up with simulator. Set the EUT to transmit under low, middle and high channel and record the power level shown on simulator.

Maximum EIRP

The relevant equation for determining the maximum ERP or EIRP from the measured RF output power is given in Equation as follows:

$$\text{ERP or EIRP} = P_{\text{Meas}} + G_{\text{T}}$$

where

ERP or EIRP effective radiated power or equivalent isotropically radiated power, respectively
(expressed in the same units as P_{Meas} , e.g., dBm or dBW)

P_{Meas} measured transmitter output power or PSD, in dBm or dBW

G_{T} gain of the transmitting antenna, in dBd (ERP) or dBi (EIRP)

4.1.3 Test Setup

Conducted Power Measurement:



4.1.4 Test Results

Conducted Output Power (dBm)

LTE Band 41 (CA 41C)

Con- figure	Com- bination	PCC							SCC							Measurement Power	
		Band	BW (MHz)	Modu- lation	RB Size	RB Offset	UL Chan.	UL Freq. (MHz)	Band	BW (MHz)	Modu- lation	RB Size	RB Offset	UL Chan.	UL Freq. (MHz)	Tx Power with UL-CA Active (dBm)	
																Total	
Intra Band Conti- guous	CA_41C	41	20	QPSK	1	0	39750	2506	41	20	QPSK	1	99	39948	2525.8	14.49	
					1	99						23.27					
		41	20	QPSK	1	0	40521	2583.1	41	20	QPSK	1	99	40719	2602.9	14.57	
					1	99						23.38					
		41	20	QPSK	1	0	41292	2660.2	41	20	QPSK	1	99	41490	2680	14.56	
					1	99						23.11					
Intra Band Conti- guous	CA_41C	41	20	16QAM	1	0	39750	2506	41	20	16QAM	1	99	39948	2525.8	13.5	
					1	99						22.29					
		41	20	16QAM	1	0	40521	2583.1	41	20	16QAM	1	99	40719	2602.9	13.63	
					1	99						22.38					
		41	20	16QAM	1	0	41292	2660.2	41	20	16QAM	1	99	41490	2680	13.61	
					1	99						22.11					
Intra Band Conti- guous	CA_41C	41	20	64QAM	1	0	39750	2506	41	20	64QAM	1	99	39948	2525.8	12.59	
					1	99						21.33					
		41	20	64QAM	1	0	40521	2583.1	41	20	64QAM	1	99	40719	2602.9	12.55	
					1	99						21.39					
		41	20	64QAM	1	0	41292	2660.2	41	20	64QAM	1	99	41490	2680	12.59	
					1	99						21.1					
Intra Band Conti- guous	CA_41C	41	20	256QAM	1	0	39750	2506	41	20	256QAM	1	99	39948	2525.8	9.69	
					1	99						18.4					
		41	20	256QAM	1	0	40521	2583.1	41	20	256QAM	1	99	40719	2602.9	9.7	
					1	99						18.38					
		41	20	256QAM	1	0	41292	2660.2	41	20	256QAM	1	99	41490	2680	9.66	
					1	99						18.12					

EIRP Power (dBm)
LTE Band 41 (CA 41C)

Con- figure	Com- bination	PCC							SCC							Measurement Power
		Band	BW (MHz)	EIRP (dBm)	RB Size	RB Offset	UL Chan.	UL Freq. (MHz)	Band	BW (MHz)	Modu- lation	RB Size	RB Offset	UL Chan.	UL Freq. (MHz)	EIRP (dBm)
																Total
Intra Band Conti- guous	CA_41C	41	20	QPSK	1	0	39750	2506	41	20	QPSK	1	99	39948	2525.8	15.64
					1	99						24.42				
		41	20	QPSK	1	0	40521	2583.1	41	20	QPSK	1	99	40719	2602.9	15.72
					1	99						24.53				
		41	20	QPSK	1	0	41292	2660.2	41	20	QPSK	1	99	41490	2680	15.71
					1	99						24.26				
Intra Band Conti- guous	CA_41C	41	20	16QAM	1	0	39750	2506	41	20	16QAM	1	99	39948	2525.8	14.65
					1	99						23.44				
		41	20	16QAM	1	0	40521	2583.1	41	20	16QAM	1	99	40719	2602.9	14.78
					1	99						23.53				
		41	20	16QAM	1	0	41292	2660.2	41	20	16QAM	1	99	41490	2680	14.76
					1	99						23.26				
Intra Band Conti- guous	CA_41C	41	20	64QAM	1	0	39750	2506	41	20	64QAM	1	99	39948	2525.8	13.74
					1	99						22.48				
		41	20	64QAM	1	0	40521	2583.1	41	20	64QAM	1	99	40719	2602.9	13.7
					1	99						22.54				
		41	20	64QAM	1	0	41292	2660.2	41	20	64QAM	1	99	41490	2680	13.74
					1	99						22.25				
Intra Band Conti- guous	CA_41C	41	20	256QAM	1	0	39750	2506	41	20	256QAM	1	99	39948	2525.8	10.84
					1	99						19.55				
		41	20	256QAM	1	0	40521	2583.1	41	20	256QAM	1	99	40719	2602.9	10.85
					1	99						19.53				
		41	20	256QAM	1	0	41292	2660.2	41	20	256QAM	1	99	41490	2680	10.81
					1	99						19.27				

4.2 Frequency Stability Measurement

4.2.1 Limits of Frequency Stability Measurement

According to the FCC part 2.1055 shall be tested the frequency stability. The rule is defined that "The frequency stability shall be sufficient to ensure that the fundamental emission stays within the authorized frequency block." The test extreme voltage is according to the 2.1055(d)(1) Vary primary supply voltage from 85 to 115 percent of the nominal value for other than hand carried battery equipment and the extreme temperature rule is comply with specification of EUT $-30^{\circ}\text{C} \sim 50^{\circ}\text{C}$.

4.2.2 Test Procedure

- Device is placed at the oven room. The oven room could control the temperatures and humidity. Power warm up is at least 15 min and power applied should perform before recording frequency error.
- EUT is connected the external power supply to control the DC input power. The test voltage range is from minimum to maximum working voltage. Each step shall be record the frequency error rate.
- The temperature range step is 10 degrees in this test items. All temperature levels shall be hold the $\pm 0.5^{\circ}\text{C}$ during the measurement testing. The each temperature step shall be at least 0.5 hours, consider the EUT could be test under the stability condition.

Note: The frequency error was recorded frequency error from the communication simulator.

4.2.3 Test Setup

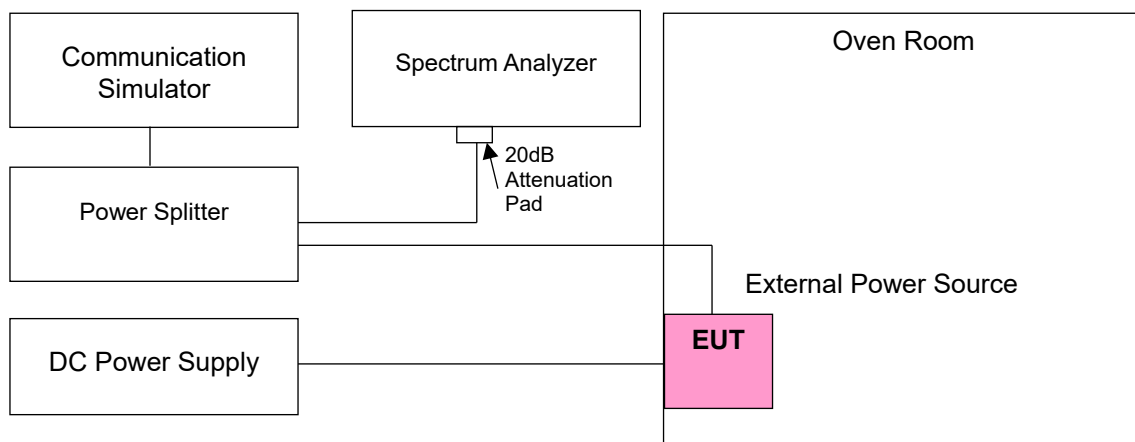

4.2.4 Test Results

Frequency Error vs. Voltage

Voltage (Volts)	LTE Band 41 (CA 41C), Channel Bandwidth 20MHz + 20MHz			
	Low Channel		High Channel	
	Frequency (MHz)	Frequency Error (ppm)	Frequency (MHz)	Frequency Error (ppm)
4.43	2660.200002	0.001	2680.000004	0.001
3.85	2660.200003	0.001	2680.000004	0.001
3.28	2660.200003	0.001	2680.000001	0.001

Note: The applicant defined the normal working voltage is from 3.28Vdc to 4.43Vdc.

Frequency Error vs. Temperature

Temp. (°C)	LTE Band 41 (CA 41C), Channel Bandwidth 20MHz + 20MHz			
	Low Channel		High Channel	
	Frequency (MHz)	Frequency Error (ppm)	Frequency (MHz)	Frequency Error (ppm)
-30	2660.200003	0.001	2680.000002	0.001
-20	2660.200002	0.001	2680.000002	0.001
-10	2660.200002	0.001	2680.000003	0.001
0	2660.200001	0.001	2680.000003	0.001
10	2660.199997	-0.001	2679.999997	-0.001
20	2660.199998	-0.001	2679.999997	-0.001
30	2660.199997	-0.001	2679.999999	-0.001
40	2660.199998	-0.001	2679.999999	0.000
50	2660.199998	-0.001	2679.999996	-0.001

4.3 Occupied Bandwidth Measurement

4.3.1 Limits of Occupied Bandwidth Measurement

The occupied bandwidth, that is the frequency bandwidth such that, below its lower and above its upper frequency limits, the mean powers radiated are each equal to 0.5 percent of the total mean power radiated by a given emission

4.3.2 Test Procedure

The transmitter output was connected to the spectrum analyzer through an attenuator. The bandwidth of the fundamental frequency was measured by spectrum analyzer with RBW = 430kHz and VBW = 1.3MHz (Channel Bandwidth: 20MHz + 20MHz). The 26dB bandwidth is defined as the total spectrum the power of which is higher than peak power minus 26dB.

4.3.3 Test Setup

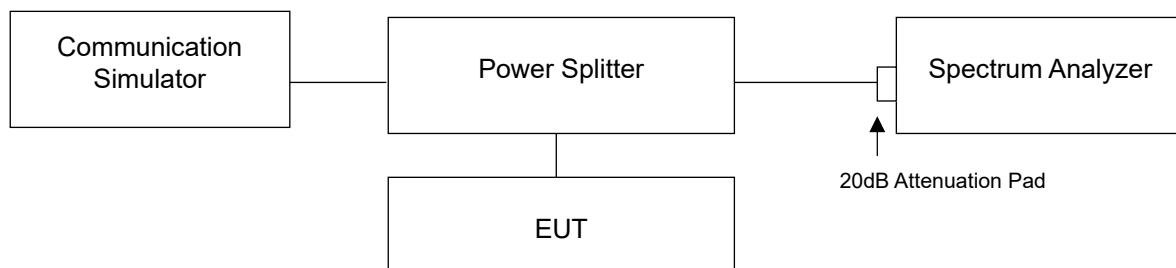

4.3.4 Test Result

Occupied Bandwidth

LTE Band 41 (CA 41C), Channel Bandwidth 20MHz + 20MHz					
Channel	Frequency (MHz)	99% Occupied Bandwidth (MHz)			
		QPSK	16QAM	64QAM	256QAM
39750 + 39948	2506.0 + 2525.8	37.45	37.49	37.49	37.48
40521 + 40719	2583.1 + 2602.9	37.53	37.51	37.52	37.52
41292 + 41490	2660.2 + 2680.0	37.37	37.30	37.43	37.34

26dB Bandwidth

LTE Band 41 (CA 41C), Channel Bandwidth 20MHz + 20MHz					
Channel	Frequency (MHz)	26dB Bandwidth (MHz)			
		QPSK	16QAM	64QAM	256QAM
39750 + 39948	2506.0 + 2525.8	39.42	39.46	39.45	39.45
40521 + 40719	2583.1 + 2602.9	39.46	39.43	39.43	39.44
41292 + 41490	2660.2 + 2680.0	38.78	38.78	38.74	38.74

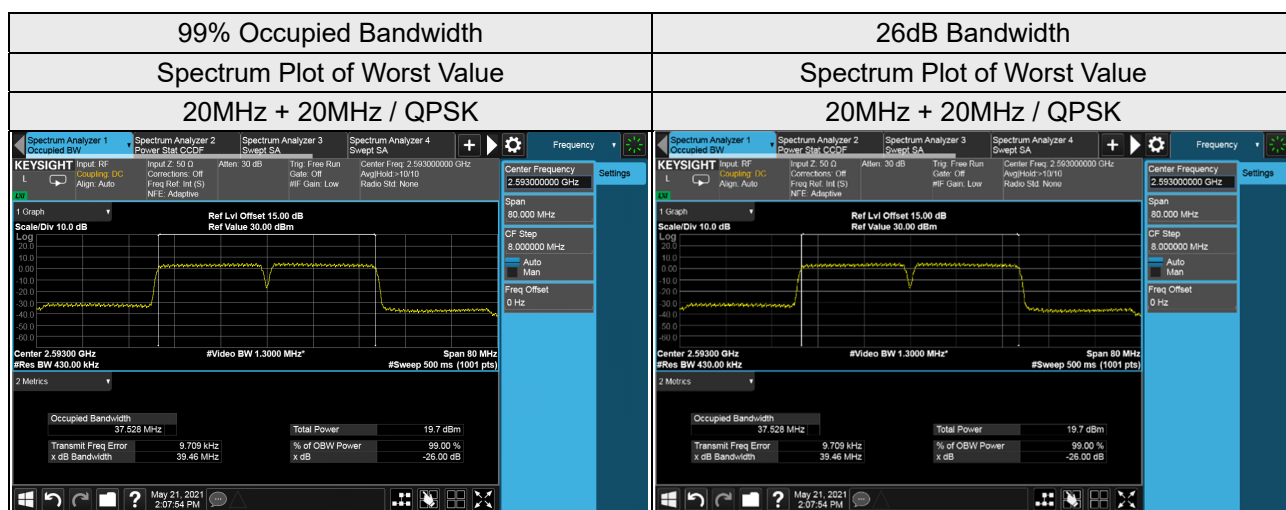

4.4 Channel Edge Measurement

4.4.1 Limits of Band Edge Measurement

According to FCC 27.53(m)(4) specified that power of any emission outside of the channel edge must be attenuated below the transmitting power (P) by a factor shall be not less than $40 + 10 \log (P)$ dB on all frequencies between the channel edge and 5 megahertz from the channel edge, $43 + 10 \log (P)$ dB on all frequencies between 5 megahertz and X megahertz from the channel edge, and $55 + 10 \log (P)$ dB on all frequencies more than X megahertz from the channel edge, where X is the greater of 6 megahertz or the actual emission bandwidth. In addition, the attenuation factor shall not be less that $43 + 10 \log (P)$ dB on all frequencies between 2490.5 MHz and 2496 MHz and $55 + 10 \log (P)$ dB at or below 2490.5 MHz. In the 1 MHz bands immediately outside and adjacent to the frequency block a resolution bandwidth of at least two percent may be employed, except when the 1 megahertz band is 2495-2496 MHz, in which case a resolution bandwidth of at least one percent may be employed.

4.4.2 Test Setup

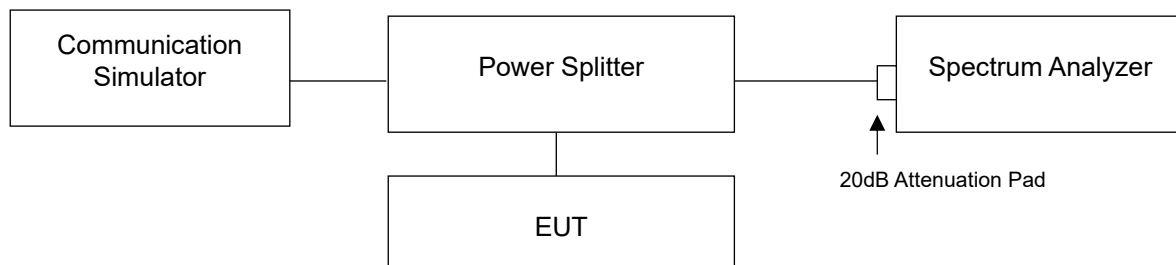

4.4.3 Test Procedures

- The EUT was set up for the rated peak power. The power was measured with Spectrum Analyzer. All measurements were done at 2 channels: low and high operational frequency range.
- For the measurement method of LTE Band 41C, please refer to 27.53(m)(4)(6).
- Record the max trace plot into the test report.

4.4.4 Test Results

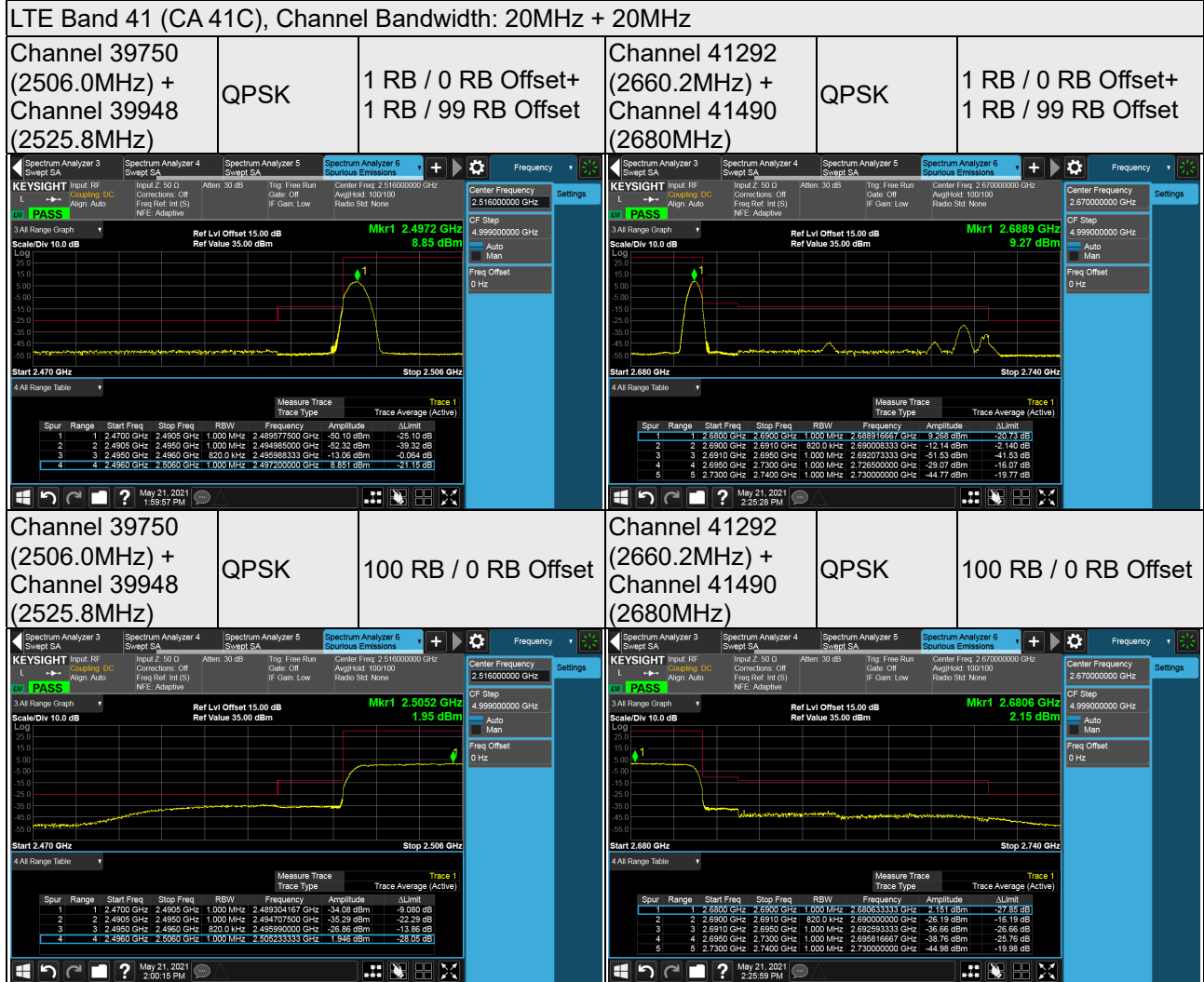

4.5 Peak to Average Ratio

4.5.1 Limits of Peak to Average Ratio Measurement

In measuring transmissions in this band using an average power technique, the peak to-average ratio (PAR) of the transmission may not exceed 13 dB

4.5.2 Test Setup

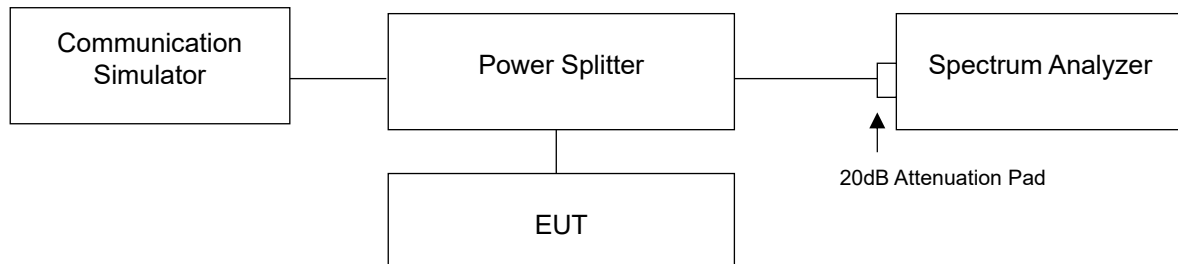

4.5.3 Test Procedures

- Set resolution/measurement bandwidth \geq signal's occupied bandwidth;
- Set the number of counts to a value that stabilizes the measured CCDF curve;
- Record the maximum PAPR level associated with a probability of 0.1%.

4.5.4 Test Results

LTE Band 41 (CA 41C), Channel Bandwidth 20MHz + 20MHz					
Channel	Frequency (MHz)	Peak To Average Ratio (dB)			
		QPSK	16QAM	64QAM	256QAM
39750 + 39948	2506.0 + 2525.8	7.01	8.12	8.90	9.38
40521 + 40719	2583.1 + 2602.9	6.07	7.52	8.07	8.38
41292 + 41490	2660.2 + 2680.0	6.42	8.03	8.34	7.98

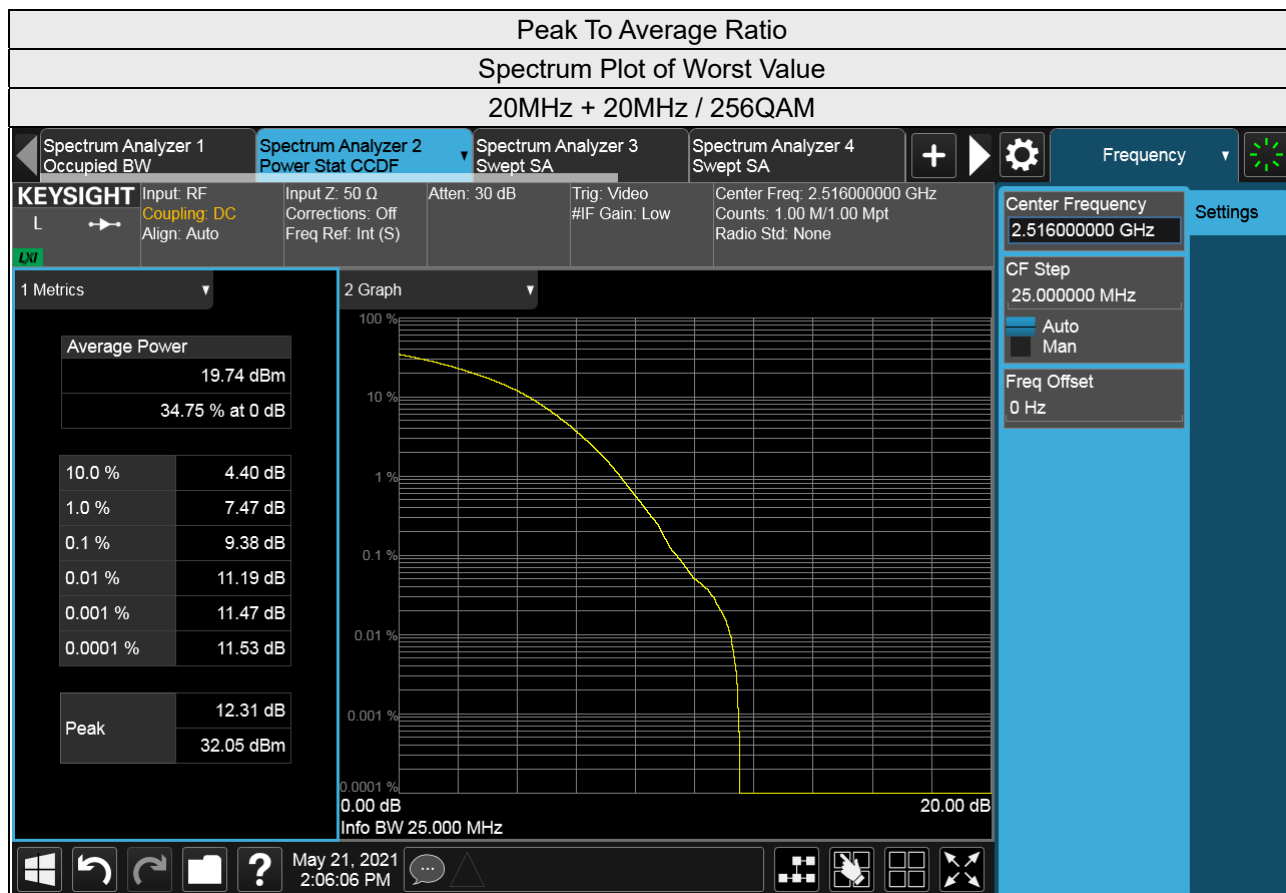

4.6 Conducted Spurious Emissions

4.6.1 Limits of Conducted Spurious Emissions Measurement

In the FCC 27.53(m)(4), On any frequency outside a licensee's frequency block, The power of any emission shall be attenuated below the transmitter power (P) by at least $55 + 10 \log (P)$ dB. The emission limit equal to -25dBm .

4.6.2 Test Setup

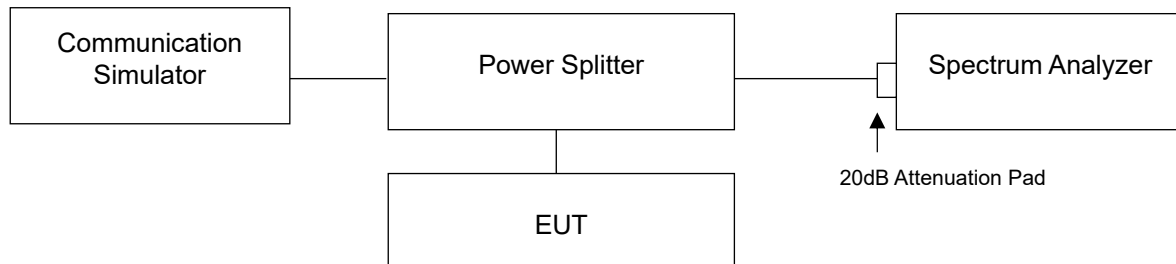

4.6.3 Test Procedure

- All measurements were done at 3 channels: low, middle and high operational frequency range.
- When the spectrum scanned from 9kHz to 40GHz, it shall be connected to the attenuator with the carried frequency.

4.6.4 Test Results

LTE Band 41 (CA 41C), Channel Band width: 20MHz + 20MHz

Channel 39750 (2506.0MHz) + 39948 (2525.8MHz)

Frequency Range : 9kHz ~ 1GHz

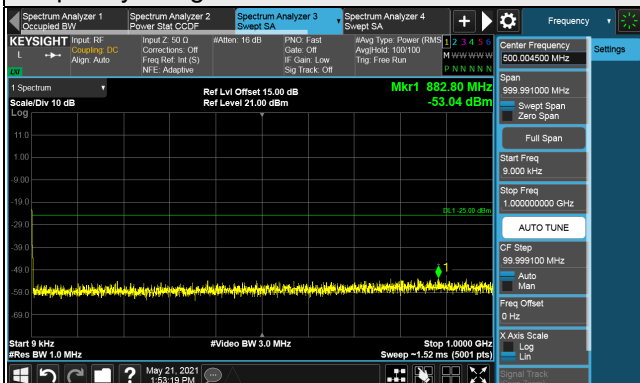

Frequency Range : 1GHz ~ 10GHz

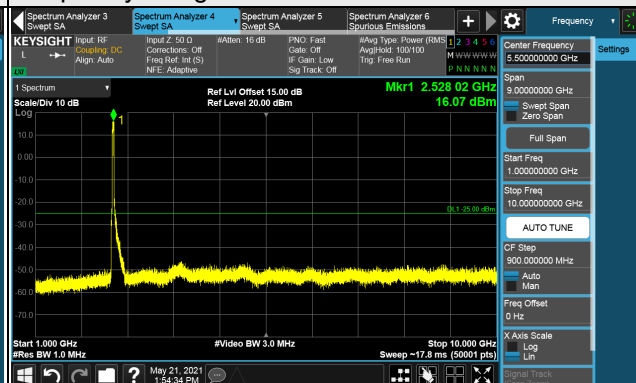

Frequency Range : 10GHz ~ 40GHz

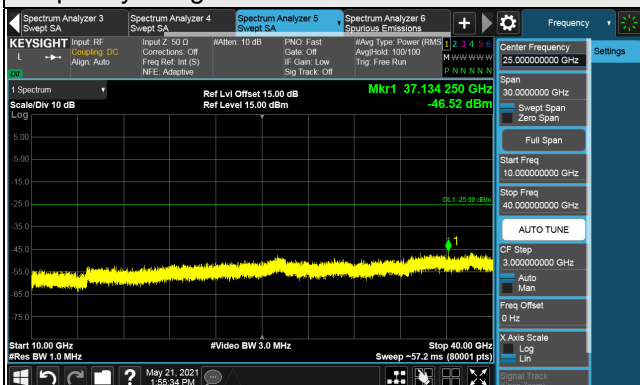

*The 9kHz signal over the limit is from Spectrum.

LTE Band 41 (CA 41C), Channel 40521 (2583.1MHz) + 40719 (2602.9MHz)

Frequency Range : 9kHz ~ 1GHz

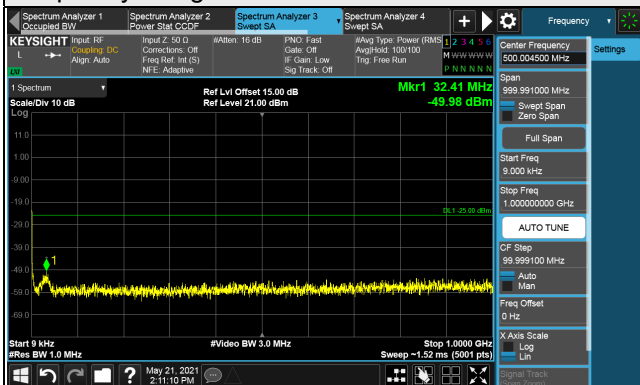

Frequency Range : 1GHz ~ 10GHz

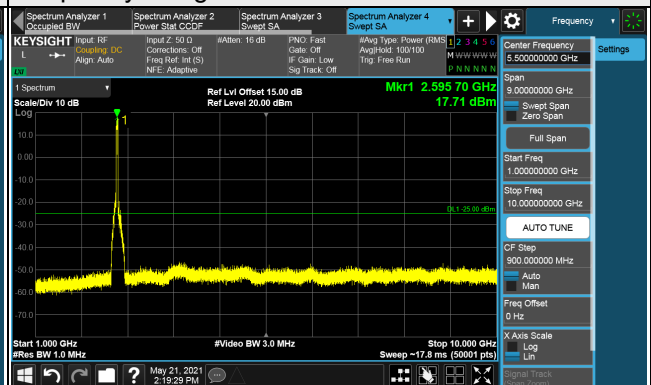

Frequency Range : 10GHz ~ 40GHz

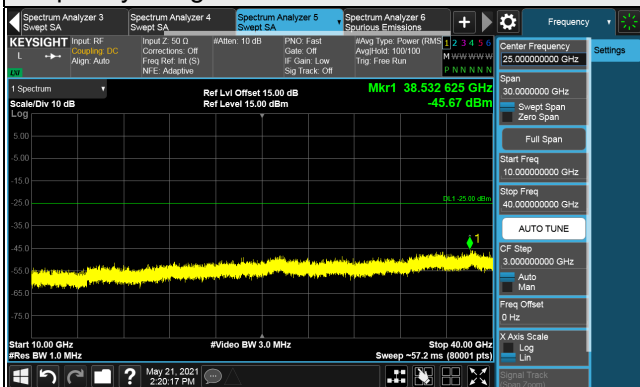

*The 9kHz signal over the limit is from Spectrum.

LTE Band 41 (CA 41C), Channel 41292 (2660.2MHz) + 41490 (2680.0MHz)

Frequency Range : 9kHz ~ 1GHz

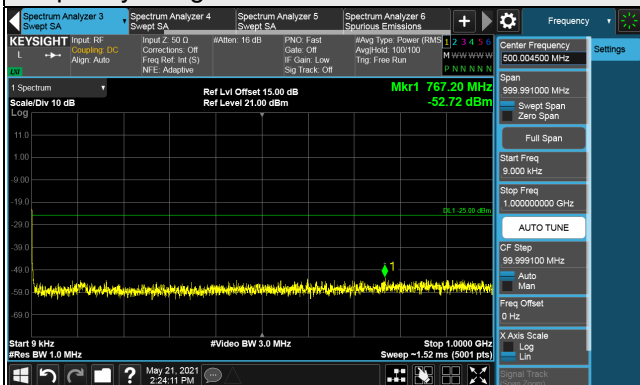

Frequency Range : 1GHz ~ 10GHz

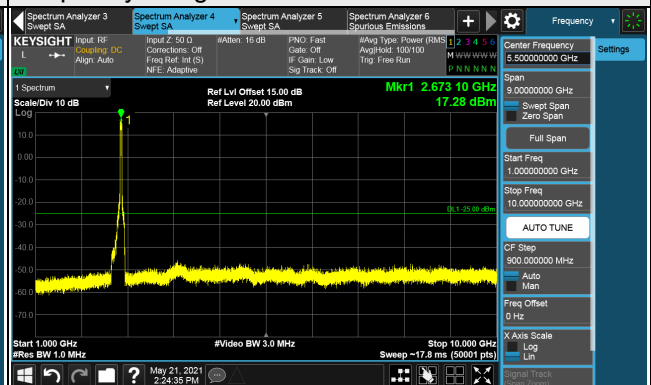

Frequency Range : 10GHz ~ 40GHz

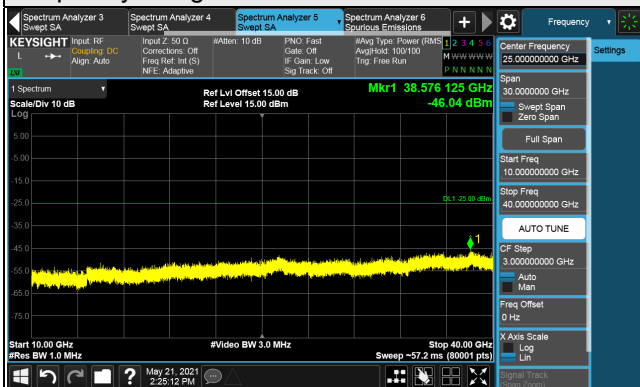

*The 9kHz signal over the limit is from Spectrum.

4.7 Radiated Emission Measurement

4.7.1 Limits of Radiated Emission Measurement

In the FCC 27.53(m) (4)(6), On any frequency outside a licensee's frequency block, The power of any emission shall be attenuated below the transmitter power (P) by at least $55 + 10 \log (P)$ dB. The emission limit equal to -25dBm .

4.7.2 Test Procedure

- a. Substitution method is used for E.I.R.P measurement. In the semi-anechoic chamber, EUT placed on the 0.8m(below or equal 1GHz) and/or 1.5m(above 1GHz) height of Turn Table, rotated the table around 360 degrees to search the maximum radiation power and receiver antenna shall be rotated vertical and horizontal polarization and moved height from 1m to 4m to find the maximum polar radiated power. The "Read Value" is the spectrum reading the maximum power value.
- b. The height of antenna is varied from one meter to four meters above the ground to determine the maximum value of the field strength. Both horizontal and vertical polarizations of the antenna are set to make the measurement.
- c. Perform a field strength measurement and record the worse read value, is the field strength value via a spectrum reading obtained corrected for antenna factor, cable loss and pre-amplifier factor and then mathematically convert the measured field strength level to EIRP/ERP level.
- d. Following C63.26 section 5.5 and 5.2.7
 - $\text{EIRP (dBm)} = E (\text{dB}\mu\text{V/m}) + 20\log(D) - 104.8$; where D is the measurement distance (in the far field region) in m.
 - $\text{ERP (dBm)} = E (\text{dB}\mu\text{V/m}) + 20\log(D) - 104.8 - 2.15$; where D is the measurement distance (in the far field region) in m.

Note:

1. The resolution bandwidth and video bandwidth of test receiver/spectrum analyzer is 1MHz/3MHz.
2. The emission levels were against the limit of frequency range 9 kHz ~ 30 MHz:
The amplitude of spurious emissions attenuated more than 20 dB below the permissible value is not required to be report.

4.7.3 Deviation from Test Standard

No deviation.

4.7.4 Test Setup

For radiated emission 30MHz to 1GHz

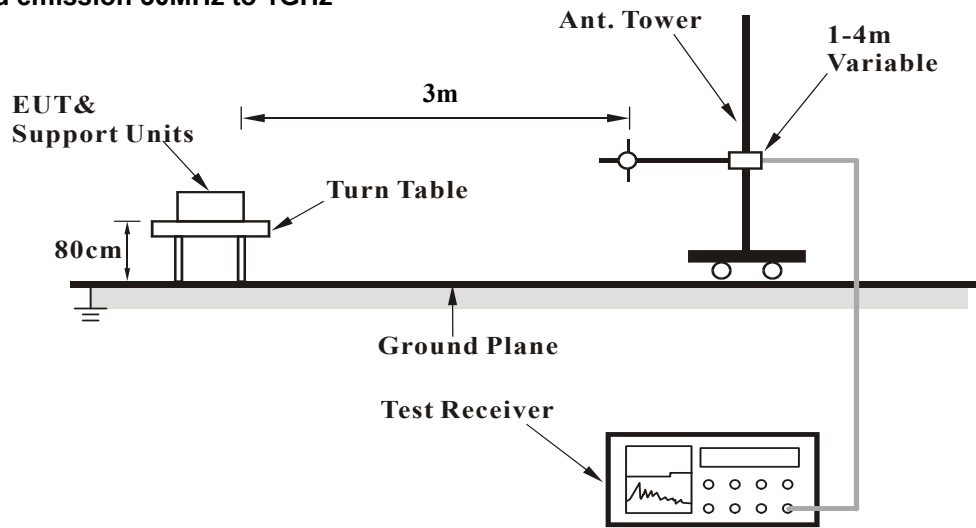

For radiated emission above 1GHz

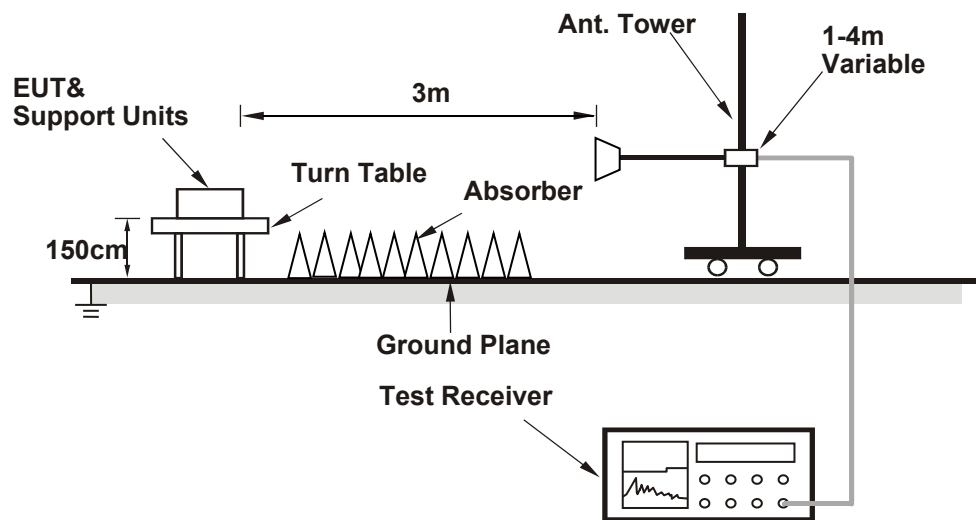

For the actual test configuration, please refer to the attached file (Test Setup Photo).

4.7.5 Test Results

Below 1GHz

LTE Band 41 (CA 41C)

Mode	TX channel 40521 (2583.1MHz) + 40719 (2602.9MHz)	Frequency Range	Below 1000 MHz
Environmental Conditions	23deg. C, 66%RH	Input Power	120Vac, 60Hz
Tested By	Titan Hsu		

Antenna Polarity & Test Distance : Horizontal at 3 m								
No	Frequency (MHz)	EIRP (dBm)	Limit (dBm)	Margin (dB)	Antenna Height (m)	Table Angle (Degree)	Raw Value (dBuV)	Correction Factor (dB/m)
1	164.96	-54.04	-25.00	-29.04	1.50 H	130	59.55	-113.59
2	280.23	-56.71	-25.00	-31.71	1.50 H	351	56.65	-113.36
3	533.28	-57.56	-25.00	-32.56	1.00 H	313	49.96	-107.52
4	770.86	-56.27	-25.00	-31.27	1.50 H	186	46.76	-103.03
5	959.23	-56.26	-25.00	-31.26	1.50 H	212	44.51	-100.77
6	1000.00	-56.31	-25.00	-31.31	1.50 H	109	43.67	-99.98

Remarks:

1. $EIRP(dBm) = Raw\ Value(dBuV) + Correction\ Factor(dB/m)$
2. $Correction\ Factor(dB/m) = Antenna\ Factor(dB/m) + Cable\ Factor(dB) - Pre-Amplifier\ Factor(dB) + 20\log(D) - 104.8$
3. $Margin\ value = EIRP - Limit\ value$
4. The other EIRP levels were very low against the limit.

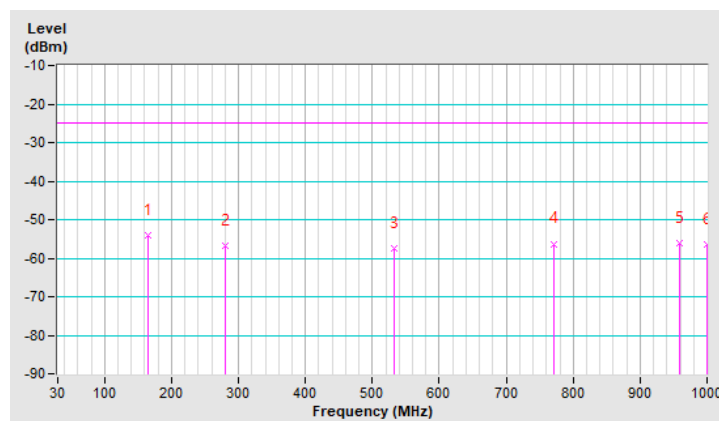

Mode	TX channel 40521 (2583.1MHz) + 40719 (2602.9MHz)	Frequency Range	Below 1000 MHz
Environmental Conditions	23deg. C, 66%RH	Input Power	120Vac, 60Hz
Tested By	Titan Hsu		

Antenna Polarity & Test Distance : Vertical at 3m								
No	Frequency (MHz)	EIRP (dBm)	Limit (dBm)	Margin (dB)	Antenna Height (m)	Table Angle (Degree)	Raw Value (dBuV)	Correction Factor (dB/m)
1	51.09	-48.80	-25.00	-23.80	1.50 V	157	65.03	-113.83
2	84.83	-50.34	-25.00	-25.34	1.00 V	132	69.28	-119.62
3	222.59	-57.68	-25.00	-32.68	1.50 V	25	59.12	-116.80
4	371.61	-61.64	-25.00	-36.64	1.50 V	200	49.40	-111.04
5	775.07	-54.53	-25.00	-29.53	1.00 V	95	48.56	-103.09
6	997.19	-55.95	-25.00	-30.95	1.50 V	157	44.12	-100.07

Remarks:

1. $EIRP(dBm) = Raw\ Value(dBuV) + Correction\ Factor(dB/m)$
2. $Correction\ Factor(dB/m) = Antenna\ Factor(dB/m) + Cable\ Factor(dB) - Pre-Amplifier\ Factor(dB) + 20\log(D) - 104.8$
3. $Margin\ value = EIRP - Limit\ value$
4. The other EIRP levels were very low against the limit.

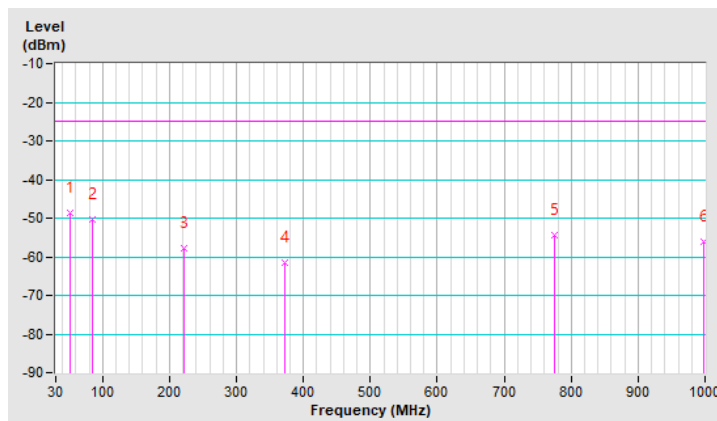

Above 1GHz
 LTE Band 41 (CA 41C)

Mode	TX channel 39750 (2506.0MHz) + 39948 (2525.8MHz)	Frequency Range	1GHz ~ 40GHz
Environmental Conditions	23deg. C, 66%RH	Input Power	120Vac, 60Hz
Tested By	Titan Hsu		

Antenna Polarity & Test Distance : Horizontal at 3 m								
No	Frequency (MHz)	EIRP (dBm)	Limit (dBm)	Margin (dB)	Antenna Height (m)	Table Angle (Degree)	Raw Value (dBuV)	Correction Factor (dB/m)
1	5012.00	-50.44	-25.00	-25.44	1.69 H	39	42.93	-93.37
2	5051.60	-50.39	-25.00	-25.39	1.59 H	54	42.97	-93.36
Antenna Polarity & Test Distance : Vertical at 3m								
No	Frequency (MHz)	EIRP (dBm)	Limit (dBm)	Margin (dB)	Antenna Height (m)	Table Angle (Degree)	Raw Value (dBuV)	Correction Factor (dB/m)
1	5012.00	-51.49	-25.00	-26.49	2.60 V	149	41.88	-93.37
2	5051.60	-51.74	-25.00	-26.74	2.59 V	155	41.62	-93.36

Remarks:

1. $EIRP(dBm) = Raw\ Value(dBuV) + Correction\ Factor(dB/m)$
2. $Correction\ Factor(dB/m) = Antenna\ Factor(dB/m) + Cable\ Factor(dB) - Pre-Amplifier\ Factor(dB) + 20\log(D) - 104.8$
3. Margin value = EIRP – Limit value
4. The other EIRP levels were very low against the limit.

Mode	TX channel 40521 (2583.1MHz) + 40719 (2602.9MHz)	Frequency Range	1GHz ~ 40GHz
Environmental Conditions	23deg. C, 66%RH	Input Power	120Vac, 60Hz
Tested By	Titan Hsu		

Antenna Polarity & Test Distance : Horizontal at 3 m								
No	Frequency (MHz)	EIRP (dBm)	Limit (dBm)	Margin (dB)	Antenna Height (m)	Table Angle (Degree)	Raw Value (dBuV)	Correction Factor (dB/m)
1	5166.20	-50.01	-25.00	-25.01	1.63 H	44	43.34	-93.35
2	5205.80	-49.50	-25.00	-24.50	1.60 H	56	43.87	-93.37
Antenna Polarity & Test Distance : Vertical at 3m								
No	Frequency (MHz)	EIRP (dBm)	Limit (dBm)	Margin (dB)	Antenna Height (m)	Table Angle (Degree)	Raw Value (dBuV)	Correction Factor (dB/m)
1	5166.20	-51.10	-25.00	-26.10	2.69 V	188	42.25	-93.35
2	5205.80	-51.50	-25.00	-26.50	2.65 V	179	41.87	-93.37

Remarks:

1. $EIRP(dBm) = Raw\ Value(dBuV) + Correction\ Factor(dB/m)$
2. $Correction\ Factor(dB/m) = Antenna\ Factor(dB/m) + Cable\ Factor(dB) - Pre-Amplifier\ Factor(dB) + 20\log(D) - 104.8$
3. $Margin\ value = EIRP - Limit\ value$
4. The other EIRP levels were very low against the limit.

Mode	TX channel 41292 (2660.2MHz) + 41490 (2680.0MHz)	Frequency Range	1GHz ~ 40GHz
Environmental Conditions	23deg. C, 66%RH	Input Power	120Vac, 60Hz
Tested By	Titan Hsu		

Antenna Polarity & Test Distance : Horizontal at 3 m								
No	Frequency (MHz)	EIRP (dBm)	Limit (dBm)	Margin (dB)	Antenna Height (m)	Table Angle (Degree)	Raw Value (dBuV)	Correction Factor (dB/m)
1	5320.40	-50.69	-25.00	-25.69	1.73 H	33	42.67	-93.36
2	5360.00	-50.30	-25.00	-25.30	1.56 H	50	43.08	-93.38
Antenna Polarity & Test Distance : Vertical at 3m								
No	Frequency (MHz)	EIRP (dBm)	Limit (dBm)	Margin (dB)	Antenna Height (m)	Table Angle (Degree)	Raw Value (dBuV)	Correction Factor (dB/m)
1	5320.40	-51.49	-25.00	-26.49	2.71 V	139	41.87	-93.36
2	5360.00	-51.97	-25.00	-26.97	2.59 V	154	41.41	-93.38

Remarks:

1. $EIRP(dBm) = Raw\ Value(dBuV) + Correction\ Factor(dB/m)$
2. $Correction\ Factor(dB/m) = Antenna\ Factor(dB/m) + Cable\ Factor(dB) - Pre-Amplifier\ Factor(dB) + 20\log(D) - 104.8$
3. $Margin\ value = EIRP - Limit\ value$
4. The other EIRP levels were very low against the limit.

5 Pictures of Test Arrangements

Please refer to the attached file (Test Setup Photo).

Appendix – Information of the Testing Laboratories

We, Bureau Veritas Consumer Products Services (H.K.) Ltd., Taoyuan Branch, were founded in 1988 to provide our best service in EMC, Radio, Telecom and Safety consultation. Our laboratories are FCC recognized accredited test firms and accredited and approved according to ISO/IEC 17025.

If you have any comments, please feel free to contact us at the following:

Lin Kou EMC/RF Lab

Tel: 886-2-26052180

Fax: 886-2-26051924

Hsin Chu EMC/RF/Telecom Lab

Tel: 886-3-6668565

Fax: 886-3-6668323

Hwa Ya EMC/RF/Safety Lab

Tel: 886-3-3183232

Fax: 886-3-3270892

Email: service.adt@tw.bureauveritas.com

Web Site: www.bureauveritas-adt.com

The address and road map of all our labs can be found in our web site also.

--- END ---