

FCC Test Report (Part 90 – LTE B26)

Report No.: RFBCKT-WTW-P21031102-6

FCC ID: HFSQTAD53

Test Model: QTAD53

Received Date: Mar. 31, 2021

Test Date: Apr. 28 ~ May 25, 2021

Issued Date: May 25, 2021

Applicant: QUANTA COMPUTER INC

Address: No. 211, Wenhua 2nd Rd., Guishan Dist., Taoyuan City 33377, Taiwan

Issued By: Bureau Veritas Consumer Products Services (H.K.) Ltd., Taoyuan Branch
Lin Kou Laboratories

Lab Address: No. 47-2, 14th Ling, Chia Pau Vil., Lin Kou Dist., New Taipei City, Taiwan

Test Location: No. 19, Hwa Ya 2nd Rd., Wen Hwa Vil., Kwei Shan Dist., Taoyuan City
33383, TAIWAN

**FCC Registration /
Designation Number:** 788550 / TW0003



This report is for your exclusive use. Any copying or replication of this report to or for any other person or entity, or use of our name or trademark, is permitted only with our prior written permission. This report sets forth our findings solely with respect to the test samples identified herein. The results set forth in this report are not indicative or representative of the quality or characteristics of the lot from which a test sample was taken or any similar or identical product unless specifically and expressly noted. Our report includes all of the tests requested by you and the results thereof based upon the information that you provided to us. You have 60 days from date of issuance of this report to notify us of any material error or omission caused by our negligence, provided, however, that such notice shall be in writing and shall specifically address the issue you wish to raise. A failure to raise such issue within the prescribed time shall constitute your unqualified acceptance of the completeness of this report, the tests conducted and the correctness of the report contents. Unless specific mention, the uncertainty of measurement has been explicitly taken into account to declare the compliance or non-compliance to the specification.

Table of Contents

Release Control Record	3
1 Certificate of Conformity	4
2 Summary of Test Results	5
2.1 Measurement Uncertainty.....	5
2.2 Test Site and Instruments.....	6
3 General Information	7
3.1 General Description of EUT.....	7
3.2 Configuration of System under Test.....	9
3.2.1 Description of Support Units.....	9
3.3 Test Mode Applicability and Tested Channel Detail.....	10
3.4 EUT Operating Conditions.....	13
3.5 General Description of Applied Standards and References.....	13
4 Test Types and Results	14
4.1 Output Power Measurement.....	14
4.1.1 Limits of Output Power Measurement.....	14
4.1.2 Test Procedures.....	14
4.1.3 Test Setup.....	14
4.1.4 Test Results.....	15
4.2 Modulation Characteristics Measurement.....	23
4.2.1 Limits of Modulation Characteristics.....	23
4.2.2 Test Procedure.....	23
4.2.3 Test Setup.....	23
4.2.4 Test Results.....	24
4.3 Frequency Stability Measurement.....	25
4.3.1 Limits of Frequency Stability Measurement.....	25
4.3.2 Test Procedure.....	25
4.3.3 Test Setup.....	25
4.3.4 Test Results.....	26
4.4 Occupied Bandwidth Measurement.....	30
4.4.1 Limits of Occupied Bandwidth Measurement.....	30
4.4.2 Test Procedure.....	30
4.4.3 Test Setup.....	30
4.4.4 Test Result.....	31
4.5 Emission Mask Measurement.....	35
4.5.1 Limits of Emission Mask Measurement.....	35
4.5.2 Test Setup.....	35
4.5.3 Test Procedures.....	35
4.5.4 Test Results.....	36
4.6 Conducted Spurious Emissions.....	40
4.6.1 Limits of Conducted Spurious Emissions Measurement.....	40
4.6.2 Test Setup.....	40
4.6.3 Test Procedure.....	40
4.6.4 Test Results.....	41
4.7 Radiated Emission Measurement.....	45
4.7.1 Limits of Radiated Emission Measurement.....	45
4.7.2 Test Procedure.....	45
4.7.3 Deviation from Test Standard.....	45
4.7.4 Test Setup.....	46
4.7.5 Test Results.....	47
5 Pictures of Test Arrangements	54
Appendix – Information of the Testing Laboratories	55

Release Control Record

Issue No.	Description	Date Issued
RFBCKT-WTW-P21031102-6	Original release	May 25, 2021

1 Certificate of Conformity

Product: 5G Hotspot

Brand: T-Mobile

Test Model: QTAD53

Sample Status: Engineering sample

Applicant: QUANTA COMPUTER INC

Test Date: Apr. 28 ~ May 25, 2021

Standards: FCC Part 90, Subpart S

The above equipment has been tested by **Bureau Veritas Consumer Products Services (H.K.) Ltd., Taoyuan Branch**, and found compliance with the requirement of the above standards. The test record, data evaluation & Equipment Under Test (EUT) configurations represented herein are true and accurate accounts of the measurements of the sample's RF characteristics under the conditions specified in this report.

Prepared by : Celine Chou , **Date:** May 25, 2021
Celine Chou / Senior Specialist

Approved by : Bruce Chen , **Date:** May 25, 2021
Bruce Chen / Senior Project Engineer

2 Summary of Test Results

Applied Standard: FCC Part 90 & Part 2			
FCC Clause	Test Item	Result	Remarks
2.1046 90.635 (b)	Effective Radiated Power	Pass	Meet the requirement of limit.
2.1047	Modulation Characteristics	Pass	Meet the requirement of limit.
2.1055 90.213	Frequency Stability	Pass	Meet the requirement of limit.
2.1049 90.209	Occupied Bandwidth	Pass	Meet the requirement of limit.
2.1051 90.691	Emission Masks	Pass	Meet the requirement of limit.
-	Band Edge Measurements	Pass	Meet the requirement of limit.
2.1051 90.691	Conducted Spurious Emissions	Pass	Meet the requirement of limit.
2.1053 90.691	Radiated Spurious Emissions	Pass	Meet the requirement of limit. Minimum passing margin is -32.70dB at 51.09MHz.

Note: Determining compliance based on the results of the compliance measurement, not taking into account measurement instrumentation uncertainty.

2.1 Measurement Uncertainty

Where relevant, the following measurement uncertainty levels have been estimated for tests performed on the EUT as specified in CISPR 16-4-2:

Measurement	Frequency	Expanded Uncertainty (k=2) (±)
Radiated Emissions up to 1 GHz	9kHz ~ 30MHz	3.04 dB
	30MHz ~ 200MHz	3.86 dB
	200MHz ~ 1000MHz	3.87 dB
Radiated Emissions above 1 GHz	1GHz ~ 18GHz	2.29 dB
	18GHz ~ 40GHz	2.29 dB

2.2 Test Site and Instruments

Description & Manufacturer	Model No.	Serial No.	Cal. Date	Cal. Due
Test Receiver ROHDE & SCHWARZ	ESR3	102579	Jul. 07, 2020	Jul. 06, 2021
Spectrum Analyzer ROHDE & SCHWARZ	FSP40	100269	Jun. 09, 2020	Jun. 08, 2021
MXG Vector signal generator Agilent	N5182B	MY53050430	Nov. 25, 2020	Nov. 24, 2021
Radio Communication Analyzer Anritsu	MT8821C	6261806803	Jan. 22, 2021	Jan. 21, 2022
BILOG Antenna SCHWARZBECK	VULB9168	9168-171	Nov. 04, 2020	Nov. 03, 2021
HORN Antenna SCHWARZBECK	9120D	209	Nov. 22, 2020	Nov. 21, 2021
HORN Antenna SCHWARZBECK	BBHA 9170	BBHA9170241	Nov. 22, 2020	Nov. 21, 2021
Loop Antenna TESEQ	HLA 6121	45745	Jul. 06, 2020	Jul. 05, 2021
Preamplifier Agilent (Below 1GHz)	8447D	2944A10738	Aug. 16, 2020	Aug. 15, 2021
Preamplifier Agilent (Above 1GHz)	8449B	3008A02465	Mar. 22, 2021	Mar. 21, 2022
RF Coaxial Cable WOKEN With 5dB Pad	8D-FB	Cable-CH3-01	Aug. 16, 2020	Aug. 15, 2021
RF signal cable HUBER+SUHNER	SUCOFLEX 104	Cable-CH3-03 (223653/4)	Aug. 16, 2020	Aug. 15, 2021
RF signal cable HUBER+SUHNER& EMCI	SUCOFLEX 104&EMC104-SM-S M-8000	Cable-CH3-03 (309224+170907)	Aug. 16, 2020	Aug. 15, 2021
Software BV ADT	ADT_Radiated_ V7.6.15.9.5	NA	NA	NA
Antenna Tower inn-co GmbH	MA 4000	013303	NA	NA
Antenna Tower Controller BV ADT	AT100	AT93021702	NA	NA
Turn Table BV ADT	TT100	TT93021702	NA	NA
Turn Table Controller BV ADT	SC100	SC93021702	NA	NA
Boresight Antenna Fixture	FBA-01	FBA-SIP01	NA	NA
Standard Temperature And Humidity Chamber GIANT FORCE	GTH-120-40-CP-AR	MAA1306-019	Sep. 10, 2020	Sep. 09, 2021
JFW 20dB attenuation	50HF-020-SMA	NA	NA	NA
True RMS Clamp Meter Fluke	325	31130711WS	Jun 06, 2020	Jun 05, 2021
DC power supply Keysight	U8002A	MY56330015	NA	NA

Note: 1. The calibration interval of the above test instruments is 12 months and the calibrations are traceable to NML/ROC and NIST/USA.
2. The test was performed in HwaYa Chamber 3.

3 General Information

3.1 General Description of EUT

Product	5G Hotspot				
Brand	T-Mobile				
Test Model	QTAD53				
Sample Status	Engineering sample				
Power Supply Rating	5Vdc / 9Vdc / 12Vdc (Adapter) 3.85Vdc (Battery)				
Modulation Type	QPSK, 16QAM, 64QAM, 256QAM				
Operating Frequency	LTE Band 26 (Channel Bandwidth 1.4MHz)	814.7MHz ~ 823.3MHz			
	LTE Band 26 (Channel Bandwidth 3MHz)	815.5MHz ~ 822.5MHz			
	LTE Band 26 (Channel Bandwidth 5MHz)	816.5MHz ~ 821.5MHz			
	LTE Band 26 (Channel Bandwidth 10MHz)	819.0MHz			
Max. ERP Power		QPSK	16QAM	64QAM	256QAM
	LTE Band 26 (Channel Bandwidth 1.4MHz)	166.341mW (22.21dBm)	130.317mW (21.15dBm)	105.439mW (20.23dBm)	64.417mW (18.09dBm)
	LTE Band 26 (Channel Bandwidth 3MHz)	163.682mW (22.14dBm)	131.220mW (21.18dBm)	102.329mW (20.10dBm)	52.000mW (17.16dBm)
	LTE Band 26 (Channel Bandwidth 5MHz)	164.816mW (22.17dBm)	131.522mW (21.19dBm)	102.565mW (20.11dBm)	52.481mW (17.20dBm)
	LTE Band 26 (Channel Bandwidth 10MHz)	164.437mW (22.16dBm)	130.918mW (21.17dBm)	101.625mW (20.07dBm)	52.119mW (17.17dBm)
Emission Designator		QPSK	16QAM	64QAM	256QAM
	LTE Band 26 (Channel Bandwidth 1.4MHz)	1M09G7D	1M09D7W	1M09D7W	1M09D7W
	LTE Band 26 (Channel Bandwidth 3MHz)	2M70G7D	2M70D7W	2M70D7W	2M69D7W
	LTE Band 26 (Channel Bandwidth 5MHz)	4M49G7D	4M49D7W	4M49D7W	4M49D7W
	LTE Band 26 (Channel Bandwidth 10MHz)	8M99G7D	8M97D7W	8M98D7W	8M97D7W
Antenna Type	Refer to Note as below				
Antenna Connector	Refer to Note as below				
Accessory Device	Refer to Note as below				
Cable Supplied	Refer to Note as below				

Note:

1. The EUT contains following accessory devices.

Product	Brand	Model	Description
Adapter 1	TEN PAO INTERNATIONAL LTD.	S018BYU1200150	I/P: 100-240Vac, 50/60Hz, 600mA O/P: 5Vdc/9Vdc/12Vdc=3A/2A/1.5A
Adapter 2	Aohai Technology Co., Ltd	A138A-120150U-US2	I/P: 100-240V~50/60Hz, 0.5A O/P: 5Vdc, 2.5A/9Vdc, 2A/12Vdc, 1.5A
USB Cable	Electronics Taiwan Ltd.	DDEMU110079	0.95m shielded USB cable without core
Battery	VEKEN	141033	3.85Vdc, 6240mAh, 24.02Wh

2. There are two sources for EUT's main board and memory. Only the supplier is different and the rest of the specifications are the same.

Sample	Item	Brand	Model
A	PCB - Main	Unimicron Technology Corporation.	12VPL4024C for MODEM board, 06VPL4028C for Main board
	Memory - Main	Nanya Technology Corporation	NM4888KSPAXAI-3E
B	PCB -Second	AKM Meadville	HI12C124A for MODEM board, HI06T221A for Main board
	Memory - Second	Jeju Semiconductor Corp.	JSFDDQ5QHAFGD-405

* After pre-tested, sample A was the worse and chosen for final test.

3. The following antennas were provided to the EUT.

LTE Band														
Ant. No.	Type	Connector	Gain (dBi)											
			B2	B4	B5	B7	B12	B13	B25	B26	B38	B41	B66	B71
0	PIFA	MUR	1.23871	3.16163	0.345671	1.15435	0.154297	-3.23099	1.23871	0.702007	0.371642	1.15435	3.16163	0.426023
1	PIFA	IPEX	-	-	-	-	-	-	-	-	-	-	-	-
2	PIFA	IPEX	0.861738	0.805343	-	-	-	-	-	-	-	-	0.805343	-
3	PIFA	MUR	-	-	-	-	-	-	-	-	-	-	-	-
4	PIFA	IPEX	-	-	-	-	-	-	-	-	-	-	-	-

* The above Antenna information is declared by manufacturer and for more detailed features description, please refer to the manufacturer's specifications, the laboratory shall not be held responsible.

3.2 Configuration of System under Test

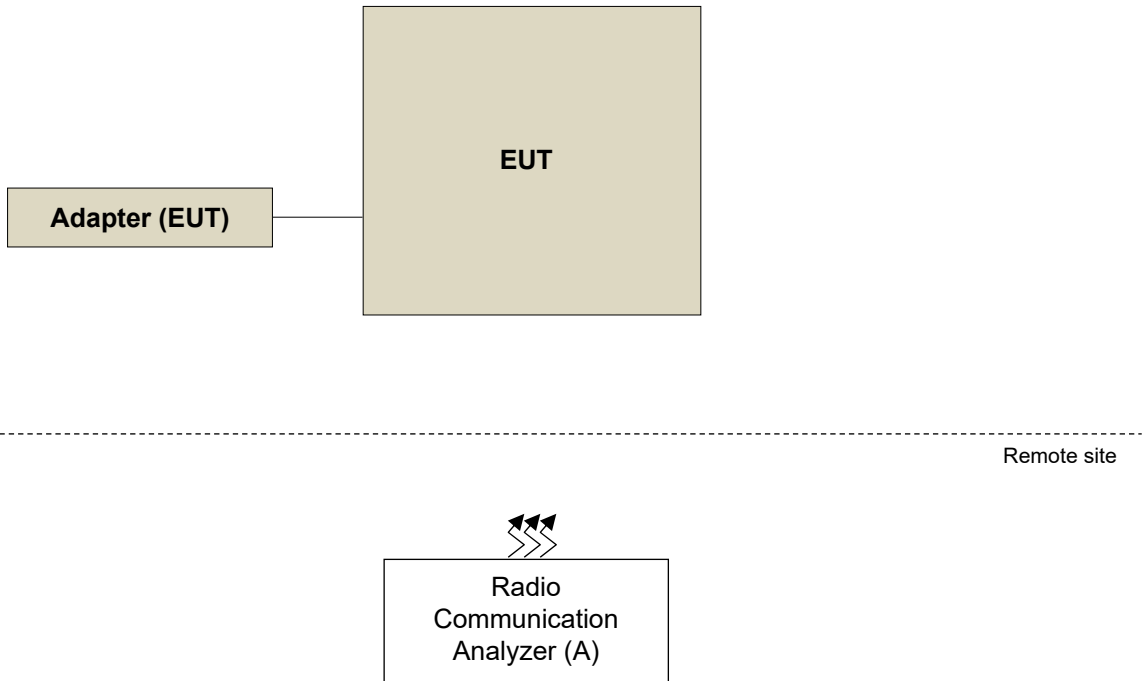

3.2.1 Description of Support Units

The EUT has been tested as an independent unit together with other necessary accessories or support units. The following support units or accessories were used to form a representative test configuration during the tests.

ID	Product	Brand	Model No.	Serial No.	FCC ID	Remarks
A.	Radio Communication Analyzer	Anritsu	MT8821C	6261806803	NA	-

Note:

1. All power cords of the above support units are non-shielded (1.8m).
2. Item A acted as a communication partner to transfer data.

3.3 Test Mode Applicability and Tested Channel Detail

Pre-Scan has been conducted to determine the worst-case mode from all possible combinations between available modulations, data rates, XYZ axis and antenna ports. The worst case was found when positioned as the table below. Following channel(s) was (were) selected for the final test as listed below:

Band	Radiated Emission
LTE Band 26	X-plane

LTE Band 26

EUT Configure Mode	Test item	Available channel	Tested channel	Channel Bandwidth	Modulation	Mode
-	ERP	26697 to 26783	26697 (814.7MHz), 26740 (819.0MHz), 26783 (823.3MHz)	1.4MHz	QPSK / 16QAM / 64QAM / 256QAM	1 RB / 0 RB Offset 1 RB / 2 RB Offset 1 RB / 5 RB Offset 3 RB / 0 RB Offset 3 RB / 1 RB Offset 3 RB / 3 RB Offset 6 RB / 0 RB Offset
		26705 to 26775	26705 (815.5MHz), 26740 (819.0MHz), 26775 (822.5MHz)	3MHz	QPSK / 16QAM / 64QAM / 256QAM	1 RB / 0 RB Offset 1 RB / 7 RB Offset 1 RB / 14 RB Offset 8 RB / 0 RB Offset 8 RB / 3 RB Offset 8 RB / 7 RB Offset 15 RB / 0 RB Offset
		26715 to 26765	26715 (816.5MHz), 26740 (819.0MHz), 26765 (821.5MHz)	5MHz	QPSK / 16QAM / 64QAM / 256QAM	1 RB / 0 RB Offset 1 RB / 12 RB Offset 1 RB / 24 RB Offset 12 RB / 0 RB Offset 12 RB / 6 RB Offset 12 RB / 13 RB Offset 25 RB / 0 RB Offset
		26740	26740 (819.0MHz)	10MHz	QPSK / 16QAM / 64QAM / 256QAM	1 RB / 0 RB Offset 1 RB / 24 RB Offset 1 RB / 49 RB Offset 25 RB / 0 RB Offset 25 RB / 12 RB Offset 25 RB / 25 RB Offset 50 RB / 0 RB Offset
-	Modulation Characteristics	26740	26740 (819.0MHz)	10MHz	QPSK / 16QAM / 64QAM / 256QAM	50 RB / 0 RB Offset
-	Frequency Stability	26697 to 26783	26697 (814.7MHz), 26783 (823.3MHz)	1.4MHz	QPSK	6 RB / 0 RB Offset
		26705 to 26775	26705 (815.5MHz), 26775 (822.5MHz)	3MHz	QPSK	15 RB / 0 RB Offset
		26715 to 26765	26715 (816.5MHz), 26765 (821.5MHz)	5MHz	QPSK	25 RB / 0 RB Offset
		26740	26740 (819.0MHz)	10MHz	QPSK	50 RB / 0 RB Offset

EUT Configure Mode	Test item	Available channel	Tested channel	Channel Bandwidth	Modulation	Mode
-	Occupied Bandwidth	26697 to 26783	26697 (814.7MHz), 26740 (819.0MHz), 26783 (823.3MHz)	1.4MHz	QPSK / 16QAM / 64QAM / 256QAM	6 RB / 0 RB Offset
		26705 to 26775	26705 (815.5MHz), 26740 (819.0MHz), 26775 (822.5MHz)	3MHz	QPSK / 16QAM / 64QAM / 256QAM	15 RB / 0 RB Offset
		26715 to 26765	26715 (816.5MHz), 26740 (819.0MHz), 26765 (821.5MHz)	5MHz	QPSK / 16QAM / 64QAM / 256QAM	25 RB / 0 RB Offset
		26740	26740 (819.0MHz)	10MHz	QPSK / 16QAM / 64QAM / 256QAM	50 RB / 0 RB Offset
-	Emission Masks	26697 to 26783	26697 (814.7MHz), 26783 (823.3MHz)	1.4MHz	QPSK	1 RB / 0 RB Offset 1 RB / 5 RB Offset 6 RB / 0 RB Offset
		26705 to 26775	26705 (815.5MHz), 26775 (822.5MHz)	3MHz	QPSK	1 RB / 0 RB Offset 1 RB / 14 RB Offset 15 RB / 0 RB Offset
		26715 to 26765	26715 (816.5MHz), 26765 (821.5MHz)	5MHz	QPSK	1 RB / 0 RB Offset 1 RB / 24 RB Offset 25 RB / 0 RB Offset
		26740	26740 (819.0MHz)	10MHz	QPSK	1 RB / 0 RB Offset 1 RB / 49 RB Offset 50 RB / 0 RB Offset
-	Conducted Emission	26697 to 26783	26697 (814.7MHz), 26740 (819.0MHz), 26783 (823.3MHz)	1.4MHz	QPSK	1 RB / 0 RB Offset
		26705 to 26775	26705 (815.5MHz), 26740 (819.0MHz), 26775 (822.5MHz)	3MHz	QPSK	1 RB / 0 RB Offset
		26715 to 26765	26715 (816.5MHz), 26740 (819.0MHz), 26765 (821.5MHz)	5MHz	QPSK	1 RB / 0 RB Offset
		26740	26740 (819.0MHz)	10MHz	QPSK	1 RB / 0 RB Offset

EUT Configure Mode	Test item	Available channel	Tested channel	Channel Bandwidth	Modulation	Mode
-	Radiated Emission Below 1GHz	26715 to 26765	26740 (819.0MHz)	5MHz	QPSK	1 RB / 0 RB Offset
-	Radiated Emission Above 1GHz	26697 to 26783	26697 (814.7MHz), 26740 (819.0MHz), 26783 (823.3MHz)	1.4MHz	QPSK	1 RB / 0 RB Offset
		26715 to 26765	26715 (816.5MHz), 26740 (819.0MHz), 26765 (821.5MHz)	5MHz	QPSK	1 RB / 0 RB Offset
		26740	26740 (819.0MHz)	10MHz	QPSK	1 RB / 0 RB Offset

Note:

1. For radiated emission below 1GHz, select the worst radiated emission channel (above 1GHz) for final testing.
2. For radiated emission above 1GHz, according to 3GPP 36.521 Section 6.6.3.1.4, choose the lowest, 5MHz & highest channel bandwidth for final test.
3. The output power for QPSK, 16QAM, 64QAM and 256QAM, measured value of QPSK is higher than 16QAM, 64QAM and 256QAM mode. Therefore, only Modulation characteristics, occupied bandwidth items had been tested under QPSK, 16QAM, 64QAM and 256QAM modes, the other test items were performed under QPSK mode only.

Test Condition:

Test Item	Environmental Conditions	Input Power	Tested By
ERP	25deg. C, 60%RH	120Vac, 60Hz	James Yang
Modulation characteristics	25deg. C, 60%RH	120Vac, 60Hz	James Yang
Frequency Stability	25deg. C, 60%RH	3.85Vdc	James Yang
Occupied Bandwidth	25deg. C, 60%RH	120Vac, 60Hz	James Yang
Emission Mask	25deg. C, 60%RH	120Vac, 60Hz	James Yang
Conducted Emission	25deg. C, 60%RH	120Vac, 60Hz	James Yang
Radiated Emission	25deg. C, 70%RH	120Vac, 60Hz	Edison Lee

3.4 EUT Operating Conditions

The EUT makes a call to the communication simulator. The communication simulator station system controlled a EUT to export maximum output power under transmission mode and specific channel frequency

3.5 General Description of Applied Standards and References

The EUT is a RF Product. According to the specifications of the manufacturer, it must comply with the requirements of the following standards:

Test Standard:

FCC 47 CFR Part 2

FCC 47 CFR Part 90

ANSI/TIA/EIA-603-E 2016

ANSI 63.26-2015

All test items have been performed and recorded as per the above standards.

References Test Guidance:

KDB 971168 D01 Power Meas License Digital Systems v03r01

KDB 971168 D02 Misc Rev Approv License Devices v02r01

All test items have been performed as a reference to the above KDB test guidance.

4 Test Types and Results

4.1 Output Power Measurement

4.1.1 Limits of Output Power Measurement

The output power shall be according to the specific rule Part 90.635 that “Mobile station are limited to 100 watts e.r.p”.

4.1.2 Test Procedures

Conducted Power Measurement:

The EUT was set up for the maximum power with LTE link data modulation and link up with simulator. Set the EUT to transmit under low, middle and high channel and record the power level shown on simulator.

Maximum EIRP / ERP

The relevant equation for determining the maximum ERP or EIRP from the measured RF output power is given in Equation as follows:

$$\text{EIRP} = P_{\text{Meas}} + G_{\text{T}}$$

$$\text{ERP} = P_{\text{Meas}} + G_{\text{T}} - 2.15$$

where

ERP or EIRP effective radiated power or equivalent isotropically radiated power, respectively
(expressed in the same units as P_{Meas} , e.g., dBm or dBW)

P_{Meas} measured transmitter output power or PSD, in dBm or dBW

G_{T} gain of the transmitting antenna, in dBd (ERP) or dBi (EIRP)

4.1.3 Test Setup

Conducted Power Measurement:

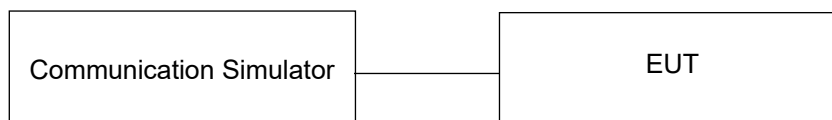

4.1.4 Test Results

Conducted Output Power (dBm)

LTE Band 26				
BW	MCS Index	RB Size	RB Offset	Mid
		Channel		26740
		Frequency (MHz)		819
10M	QPSK	1	0	23.61
		1	24	23.57
		1	49	23.48
		25	0	22.69
		25	12	22.64
		25	25	22.55
		50	0	22.55
10M	16QAM	1	0	22.62
		1	24	22.57
		1	49	22.56
		25	0	21.50
		25	12	21.53
		25	25	21.45
		50	0	21.49
10M	64QAM	1	0	21.52
		1	24	21.48
		1	49	21.46
		25	0	20.67
		25	12	20.63
		25	25	20.59
		50	0	20.57
10M	256QAM	1	0	18.57
		1	24	18.62
		1	49	18.60
		25	0	18.57
		25	12	18.48
		25	25	18.50
		50	0	18.46

LTE Band 26						
BW	MCS Index	RB Size	RB Offset	Low	Mid	High
		Channel		26715	26740	26765
		Frequency (MHz)		816.5	819	821.5
5M	QPSK	1	0	23.60	23.61	23.62
		1	12	23.59	23.57	23.59
		1	24	23.46	23.48	23.56
		12	0	22.66	22.69	22.74
		12	6	22.65	22.64	22.69
		12	13	22.61	22.55	22.65
		25	0	22.51	22.55	22.58
5M	16QAM	1	0	22.55	22.62	22.64
		1	12	22.57	22.57	22.63
		1	24	22.48	22.56	22.58
		12	0	21.52	21.50	21.59
		12	6	21.52	21.53	21.57
		12	13	21.48	21.45	21.54
		25	0	21.45	21.49	21.51
5M	64QAM	1	0	21.52	21.52	21.56
		1	12	21.47	21.48	21.53
		1	24	21.50	21.46	21.51
		12	0	20.67	20.67	20.73
		12	6	20.70	20.63	20.71
		12	13	20.54	20.59	20.62
		25	0	20.52	20.57	20.61
5M	256QAM	1	0	18.62	18.57	18.65
		1	12	18.54	18.62	18.63
		1	24	18.55	18.60	18.61
		12	0	18.56	18.57	18.58
		12	6	18.52	18.48	18.56
		12	13	18.47	18.50	18.53
		25	0	18.41	18.46	18.51

LTE Band 26						
BW	MCS Index	RB Size	RB Offset	Low	Mid	High
		Channel		26705	26740	26775
		Frequency (MHz)		815.5	819	822.5
3M	QPSK	1	0	23.59	23.46	23.56
		1	7	23.57	23.47	23.57
		1	14	23.48	23.44	23.53
		8	0	22.64	22.58	22.68
		8	3	22.63	22.52	22.67
		8	7	22.65	22.50	22.53
		15	0	22.53	22.55	22.45
3M	16QAM	1	0	22.63	22.53	22.56
		1	7	22.57	22.50	22.50
		1	14	22.52	22.49	22.47
		8	0	21.59	21.37	21.44
		8	3	21.50	21.49	21.44
		8	7	21.52	21.34	21.45
		15	0	21.45	21.39	21.36
3M	64QAM	1	0	21.48	21.51	21.55
		1	7	21.49	21.46	21.42
		1	14	21.44	21.31	21.46
		8	0	20.63	20.64	20.71
		8	3	20.70	20.51	20.57
		8	7	20.59	20.59	20.51
		15	0	20.59	20.48	20.49
3M	256QAM	1	0	18.60	18.51	18.61
		1	7	18.53	18.47	18.55
		1	14	18.52	18.59	18.60
		8	0	18.49	18.50	18.46
		8	3	18.50	18.37	18.50
		8	7	18.43	18.47	18.45
		15	0	18.48	18.35	18.39

LTE Band 26						
BW	MCS Index	RB Size	RB Offset	Low	Mid	High
		Channel		26697	26740	26783
		Frequency (MHz)		814.7	819	823.3
1.4M	QPSK	1	0	23.60	23.54	23.49
		1	2	23.59	23.50	23.49
		1	5	23.51	23.42	23.45
		3	0	22.65	23.66	23.64
		3	1	22.66	23.61	23.61
		3	3	22.65	23.46	23.62
		6	0	22.49	22.40	22.52
1.4M	16QAM	1	0	22.60	22.47	22.55
		1	2	22.57	22.43	22.49
		1	5	22.56	22.41	22.53
		3	0	21.58	22.35	22.47
		3	1	21.51	22.44	22.51
		3	3	21.45	22.42	22.49
		6	0	21.49	21.34	21.37
1.4M	64QAM	1	0	21.48	21.45	21.50
		1	2	21.45	21.45	21.50
		1	5	21.43	21.37	21.41
		3	0	20.70	21.66	21.62
		3	1	20.63	21.58	21.68
		3	3	20.55	21.53	21.47
		6	0	20.60	20.47	20.58
1.4M	256QAM	1	0	18.55	18.54	18.63
		1	2	18.62	18.54	18.56
		1	5	18.60	18.54	18.58
		3	0	18.55	19.48	19.54
		3	1	18.53	19.38	19.46
		3	3	18.47	19.37	19.46
		6	0	18.48	18.45	18.46

ERP Power (dBm)

LTE Band 26				
BW	MCS Index	RB Size	RB Offset	Mid
		Channel		26740
		Frequency (MHz)		819
10M	QPSK	1	0	22.16
		1	24	22.12
		1	49	22.03
		25	0	21.24
		25	12	21.19
		25	25	21.10
		50	0	21.10
10M	16QAM	1	0	21.17
		1	24	21.12
		1	49	21.11
		25	0	20.05
		25	12	20.08
		25	25	20.00
		50	0	20.04
10M	64QAM	1	0	20.07
		1	24	20.03
		1	49	20.01
		25	0	19.22
		25	12	19.18
		25	25	19.14
		50	0	19.12
10M	256QAM	1	0	17.12
		1	24	17.17
		1	49	17.15
		25	0	17.12
		25	12	17.03
		25	25	17.05
		50	0	17.01

LTE Band 26						
BW	MCS Index	RB Size	RB Offset	Low	Mid	High
		Channel		26715	26740	26765
		Frequency (MHz)		816.5	819	821.5
5M	QPSK	1	0	22.15	22.16	22.17
		1	12	22.14	22.12	22.14
		1	24	22.01	22.03	22.11
		12	0	21.21	21.24	21.29
		12	6	21.20	21.19	21.24
		12	13	21.16	21.10	21.20
		25	0	21.06	21.10	21.13
5M	16QAM	1	0	21.10	21.17	21.19
		1	12	21.12	21.12	21.18
		1	24	21.03	21.11	21.13
		12	0	20.07	20.05	20.14
		12	6	20.07	20.08	20.12
		12	13	20.03	20.00	20.09
		25	0	20.00	20.04	20.06
5M	64QAM	1	0	20.07	20.07	20.11
		1	12	20.02	20.03	20.08
		1	24	20.05	20.01	20.06
		12	0	19.22	19.22	19.28
		12	6	19.25	19.18	19.26
		12	13	19.09	19.14	19.17
		25	0	19.07	19.12	19.16
5M	256QAM	1	0	17.17	17.12	17.20
		1	12	17.09	17.17	17.18
		1	24	17.10	17.15	17.16
		12	0	17.11	17.12	17.13
		12	6	17.07	17.03	17.11
		12	13	17.02	17.05	17.08
		25	0	16.96	17.01	17.06

LTE Band 26						
BW	MCS Index	RB Size	RB Offset	Low	Mid	High
		Channel		26705	26740	26775
		Frequency (MHz)		815.5	819	822.5
3M	QPSK	1	0	22.14	22.01	22.11
		1	7	22.12	22.02	22.12
		1	14	22.03	21.99	22.08
		8	0	21.19	21.13	21.23
		8	3	21.18	21.07	21.22
		8	7	21.20	21.05	21.08
		15	0	21.08	21.10	21.00
3M	16QAM	1	0	21.18	21.08	21.11
		1	7	21.12	21.05	21.05
		1	14	21.07	21.04	21.02
		8	0	20.14	19.92	19.99
		8	3	20.05	20.04	19.99
		8	7	20.07	19.89	20.00
		15	0	20.00	19.94	19.91
3M	64QAM	1	0	20.03	20.06	20.10
		1	7	20.04	20.01	19.97
		1	14	19.99	19.86	20.01
		8	0	19.18	19.19	19.26
		8	3	19.25	19.06	19.12
		8	7	19.14	19.14	19.06
		15	0	19.14	19.03	19.04
3M	256QAM	1	0	17.15	17.06	17.16
		1	7	17.08	17.02	17.10
		1	14	17.07	17.14	17.15
		8	0	17.04	17.05	17.01
		8	3	17.05	16.92	17.05
		8	7	16.98	17.02	17.00
		15	0	17.03	16.90	16.94

LTE Band 26						
BW	MCS Index	RB Size	RB Offset	Low	Mid	High
		Channel		26697	26740	26783
		Frequency (MHz)		814.7	819	823.3
1.4M	QPSK	1	0	22.15	22.09	22.04
		1	2	22.14	22.05	22.04
		1	5	22.06	21.97	22.00
		3	0	21.20	22.21	22.19
		3	1	21.21	22.16	22.16
		3	3	21.20	22.01	22.17
		6	0	21.04	20.95	21.07
1.4M	16QAM	1	0	21.15	21.02	21.10
		1	2	21.12	20.98	21.04
		1	5	21.11	20.96	21.08
		3	0	20.13	20.90	21.02
		3	1	20.06	20.99	21.06
		3	3	20.00	20.97	21.04
		6	0	20.04	19.89	19.92
1.4M	64QAM	1	0	20.03	20.00	20.05
		1	2	20.00	20.00	20.05
		1	5	19.98	19.92	19.96
		3	0	19.25	20.21	20.17
		3	1	19.18	20.13	20.23
		3	3	19.10	20.08	20.02
		6	0	19.15	19.02	19.13
1.4M	256QAM	1	0	17.10	17.09	17.18
		1	2	17.17	17.09	17.11
		1	5	17.15	17.09	17.13
		3	0	17.10	18.03	18.09
		3	1	17.08	17.93	18.01
		3	3	17.02	17.92	18.01
		6	0	17.03	17.00	17.01

4.2 Modulation Characteristics Measurement

4.2.1 Limits of Modulation Characteristics

N/A

4.2.2 Test Procedure

Connect the EUT to Communication Simulator via the antenna connector, The frequency band is set as EUT supported Modulation and Channels, the EUT output is matched with 50 ohm load, the waveform quality and constellation of the EUT was tested.

4.2.3 Test Setup



4.2.4 Test Results

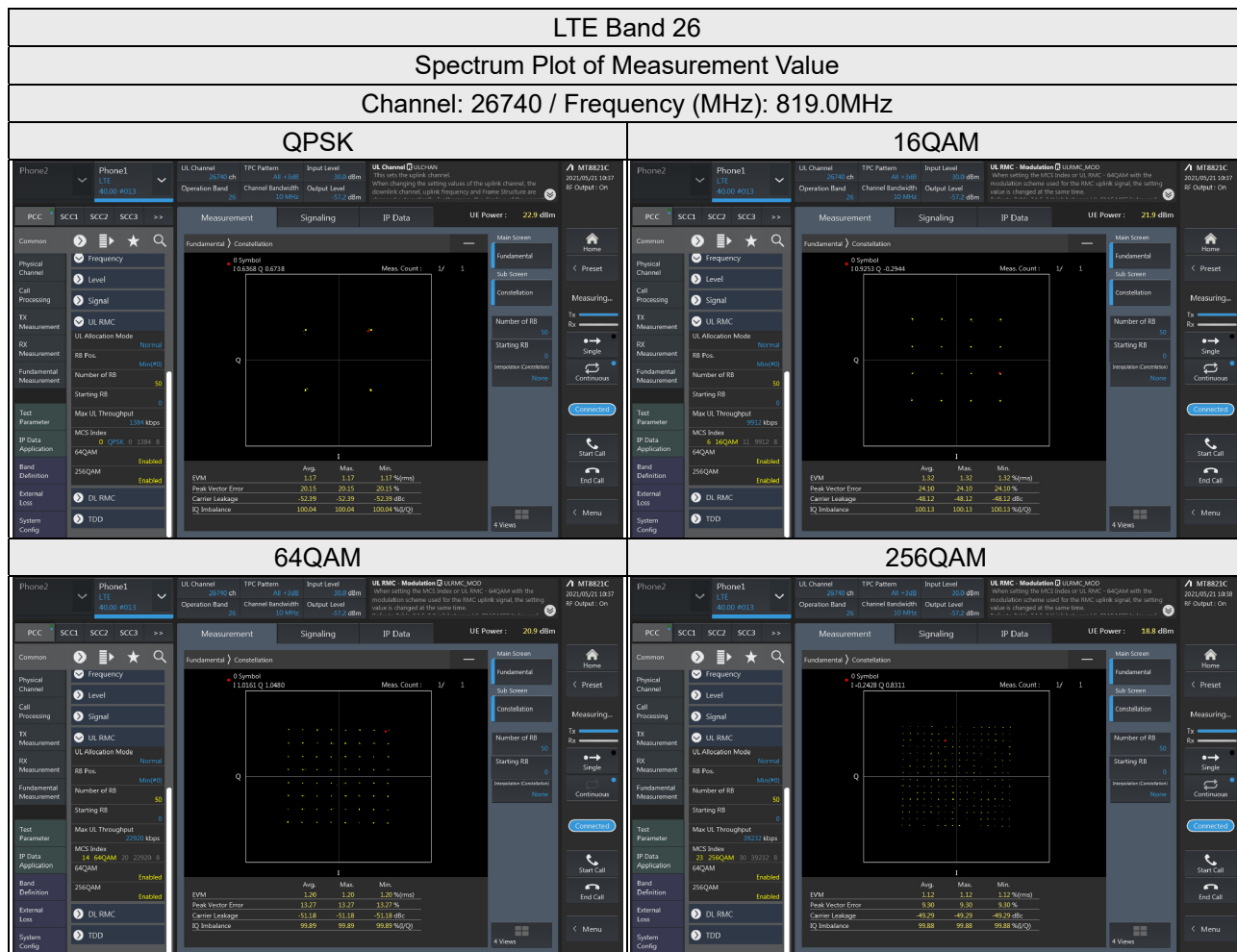

4.3 Frequency Stability Measurement

4.3.1 Limits of Frequency Stability Measurement

1.5 ppm is for base and fixed station. 2.5 ppm is for mobile station.

4.3.2 Test Procedure

- Device is placed at the oven room. The oven room could control the temperatures and humidity. Power warm up is at least 15 min and power applied should perform before recording frequency error.
- EUT is connected the external power supply to control the DC input power. The test voltage range is from minimum to maximum working voltage. Each step shall be record the frequency error rate.
- The temperature range step is 10 degrees in this test items. All temperature levels shall be hold the ± 0.5 °C during the measurement testing. The each temperature step shall be at least 0.5 hours, consider the EUT could be test under the stability condition.

Note: The frequency error was recorded frequency error from the communication simulator.

4.3.3 Test Setup

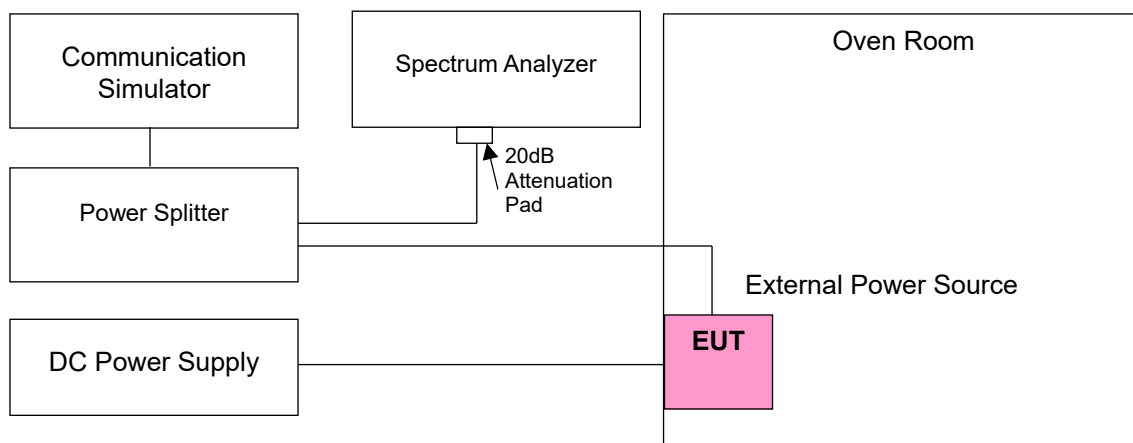

4.3.4 Test Results

Frequency Error vs. Voltage

Voltage (Vdc)	LTE Band 26			
	Channel Bandwidth: 1.4 MHz			
	Low Channel		High Channel	
	Frequency (MHz)	Frequency Error (ppm)	Frequency (MHz)	Frequency Error (ppm)
4.43	814.700003	0.004	823.300002	0.003
3.85	814.700003	0.004	823.300003	0.003
3.28	814.700004	0.005	823.300001	0.002

Note: The applicant defined the normal working voltage is from 3.28Vdc to 4.43Vdc.

Frequency Error vs. Temperature

Temp. (°C)	LTE Band 26			
	Channel Bandwidth: 1.4 MHz			
	Low Channel		High Channel	
	Frequency (MHz)	Frequency Error (ppm)	Frequency (MHz)	Frequency Error (ppm)
-30	814.700001	0.001	823.300001	0.002
-20	814.700004	0.004	823.300001	0.002
-10	814.700002	0.003	823.300004	0.005
0	814.700003	0.004	823.300003	0.003
10	814.699998	-0.003	823.299998	-0.003
20	814.699998	-0.003	823.299996	-0.004
30	814.699999	-0.001	823.299998	-0.002
40	814.699997	-0.004	823.299997	-0.004
50	814.699998	-0.003	823.299998	-0.002

Frequency Error vs. Voltage

Voltage (Vdc)	LTE Band 26			
	Channel Bandwidth: 3MHz			
	Low Channel		High Channel	
	Frequency (MHz)	Frequency Error (ppm)	Frequency (MHz)	Frequency Error (ppm)
4.43	815.500003	0.003	822.500002	0.003
3.85	815.500004	0.005	822.500003	0.003
3.28	815.500003	0.004	822.500004	0.004

Note: The applicant defined the normal working voltage is from 3.28Vdc to 4.43Vdc.

Frequency Error vs. Temperature

Temp. (°C)	LTE Band 26			
	Channel Bandwidth: 3MHz			
	Low Channel		High Channel	
	Frequency (MHz)	Frequency Error (ppm)	Frequency (MHz)	Frequency Error (ppm)
-30	815.500004	0.004	822.500004	0.005
-20	815.500002	0.002	822.500002	0.002
-10	815.500004	0.005	822.500001	0.001
0	815.500002	0.002	822.500003	0.004
10	815.499998	-0.003	822.499998	-0.003
20	815.499998	-0.003	822.499998	-0.003
30	815.499997	-0.003	822.499998	-0.003
40	815.499998	-0.003	822.499999	-0.002
50	815.499996	-0.005	822.499998	-0.003

Frequency Error vs. Voltage

Voltage (Vdc)	LTE Band 26			
	Channel Bandwidth: 5MHz			
	Low Channel		High Channel	
	Frequency (MHz)	Frequency Error (ppm)	Frequency (MHz)	Frequency Error (ppm)
4.43	816.500002	0.003	821.500002	0.002
3.85	816.500001	0.002	821.500001	0.001
3.28	816.500002	0.002	821.500001	0.001

Note: The applicant defined the normal working voltage is from 3.28Vdc to 4.43Vdc.

Frequency Error vs. Temperature

Temp. (°C)	LTE Band 26			
	Channel Bandwidth: 5MHz			
	Low Channel		High Channel	
	Frequency (MHz)	Frequency Error (ppm)	Frequency (MHz)	Frequency Error (ppm)
-30	816.500003	0.004	821.500003	0.004
-20	816.500002	0.002	821.500002	0.002
-10	816.500004	0.005	821.500002	0.002
0	816.500002	0.003	821.500004	0.005
10	816.499997	-0.004	821.499999	-0.001
20	816.499998	-0.002	821.499996	-0.005
30	816.499996	-0.005	821.499996	-0.005
40	816.499996	-0.005	821.499996	-0.005
50	816.499999	-0.002	821.499997	-0.004

Frequency Error vs. Voltage

Voltage (Vdc)	LTE Band 26	
	Channel Bandwidth: 10 MHz	
	Frequency (MHz)	Frequency Error (ppm)
4.43	819.000002	0.002
3.85	819.000001	0.001
3.28	819.000002	0.002

Note: The applicant defined the normal working voltage is from 3.28Vdc to 4.43Vdc.

Frequency Error vs. Temperature

Temp. (°C)	LTE Band 26	
	Channel Bandwidth: 10 MHz	
	Frequency (MHz)	Frequency Error (ppm)
-30	819.000002	0.003
-20	819.000003	0.004
-10	819.000004	0.004
0	819.000003	0.004
10	818.999998	-0.002
20	818.999997	-0.004
30	818.999997	-0.004
40	818.999997	-0.004
50	818.999996	-0.005

4.4 Occupied Bandwidth Measurement

4.4.1 Limits of Occupied Bandwidth Measurement

The width of a frequency band such that, below the lower and above the upper frequency limits, the mean powers emitted are each equal to a specified percentage 0.5 % of the total mean power of a given emission.

4.4.2 Test Procedure

The EUT makes a call to the communication simulator. All measurements were done at low, middle and high operational frequency range. The communication simulator station system controlled a EUT to export maximum output power under transmission mode and specific channel frequency. Measurement method, please refer to section 5.4.4 of ANSI C63.26. Use OBW measurement function of Spectrum analyzer to measure 99 % occupied bandwidth.

For the 26dBc bandwidth measurement method, please refer to section 5.4.3 of ANSI C63.26.

4.4.3 Test Setup

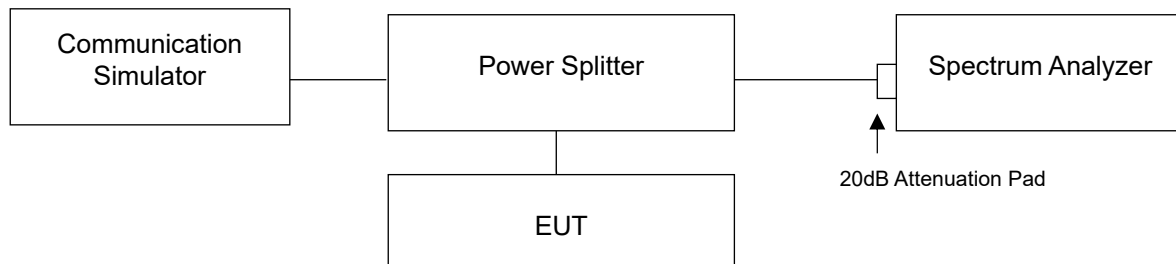

4.4.4 Test Result

Occupied Bandwidth

LTE Band 26, Channel Bandwidth 1.4MHz					
Channel	Frequency (MHz)	99% Occupied Bandwidth (MHz)			
		QPSK	16QAM	64QAM	256QAM
26697	814.7	1.09	1.09	1.09	1.08
26740	819.0	1.09	1.09	1.09	1.09
26783	823.3	1.09	1.09	1.09	1.08
LTE Band 26, Channel Bandwidth 3MHz					
Channel	Frequency (MHz)	99% Occupied Bandwidth (MHz)			
		QPSK	16QAM	64QAM	256QAM
26705	815.5	2.70	2.70	2.70	2.69
26740	819.0	2.70	2.70	2.70	2.69
26775	822.5	2.70	2.70	2.70	2.69
LTE Band 26, Channel Bandwidth 5MHz					
Channel	Frequency (MHz)	99% Occupied Bandwidth (MHz)			
		QPSK	16QAM	64QAM	256QAM
26715	816.5	4.49	4.49	4.49	4.49
26740	819.0	4.49	4.49	4.49	4.49
26765	821.5	4.49	4.49	4.49	4.49
LTE Band 26, Channel Bandwidth 10MHz					
Channel	Frequency (MHz)	99% Occupied Bandwidth (MHz)			
		QPSK	16QAM	64QAM	256QAM
26740	819.0	8.99	8.97	8.98	8.97

Spectrum Plot of Worst Value

1.4MHz / 64QAM

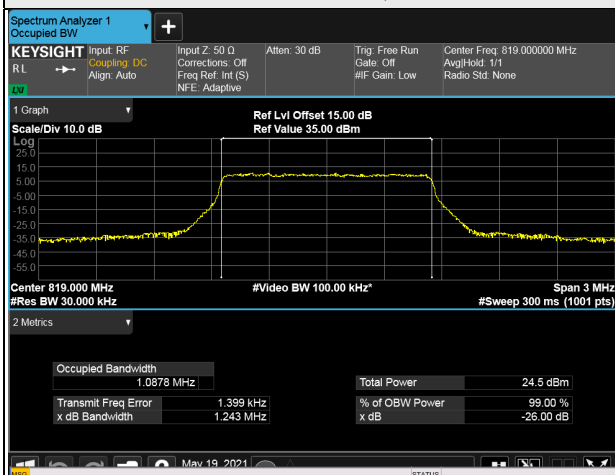

3MHz / 16QAM

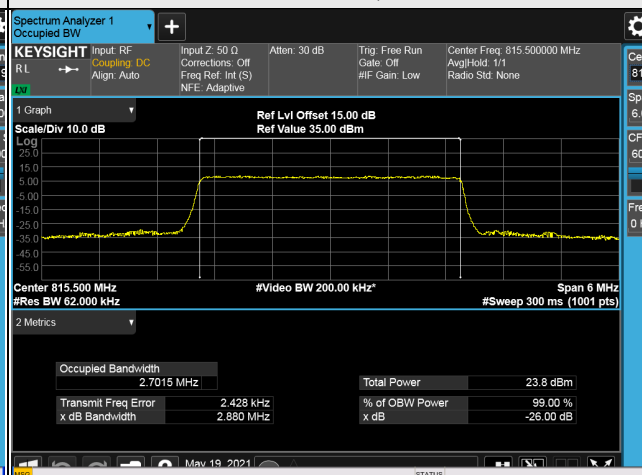

5MHz / QPSK

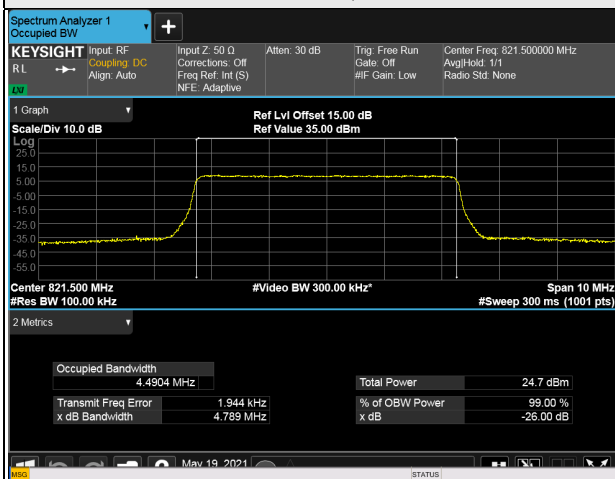

10MHz / QPSK

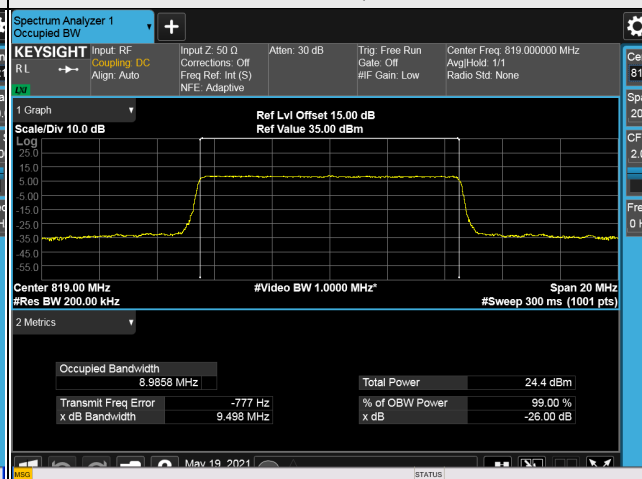

26dB Bandwidth

LTE Band 26, Channel Bandwidth 1.4MHz					
Channel	Frequency (MHz)	26dB Bandwidth (MHz)			
		QPSK	16QAM	64QAM	256QAM
26697	814.7	1.23	1.25	1.25	1.23
26740	819.0	1.24	1.25	1.24	1.24
26783	823.3	1.25	1.25	1.25	1.22
LTE Band 26, Channel Bandwidth 3MHz					
Channel	Frequency (MHz)	26dB Bandwidth (MHz)			
		QPSK	16QAM	64QAM	256QAM
26705	815.5	2.89	2.88	2.88	2.88
26740	819.0	2.89	2.87	2.87	2.88
26775	822.5	2.88	2.88	2.88	2.87
LTE Band 26, Channel Bandwidth 5MHz					
Channel	Frequency (MHz)	26dB Bandwidth (MHz)			
		QPSK	16QAM	64QAM	256QAM
26715	816.5	4.79	4.78	4.80	4.77
26740	819.0	4.78	4.79	4.79	4.77
26765	821.5	4.79	4.80	4.79	4.78
LTE Band 26, Channel Bandwidth 10MHz					
Channel	Frequency (MHz)	26dB Bandwidth (MHz)			
		QPSK	16QAM	64QAM	256QAM
26740	819.0	9.50	9.51	9.51	9.49

Spectrum Plot of Worst Value

1.4MHz / 16QAM

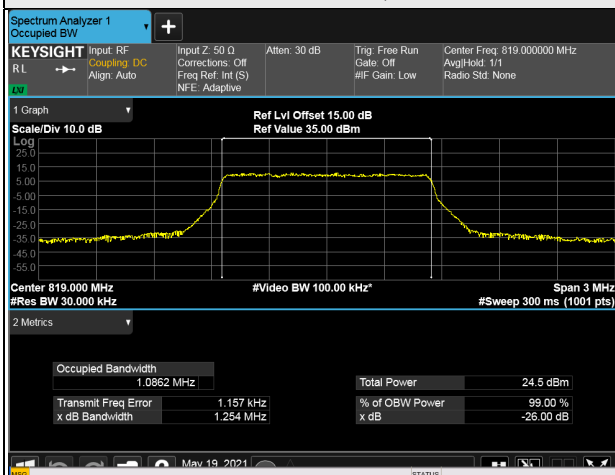

3MHz / QPSK

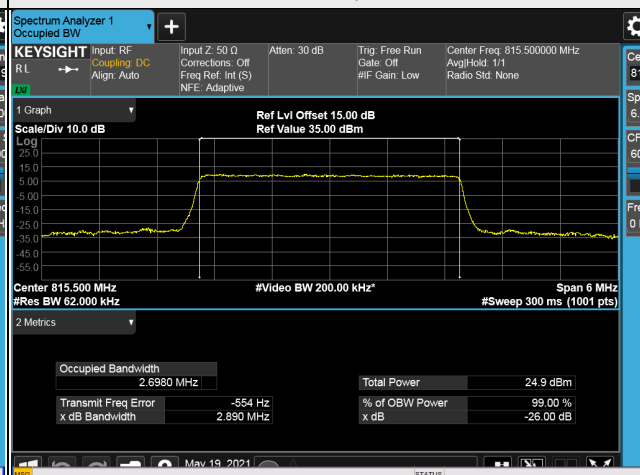

5MHz / 16QAM

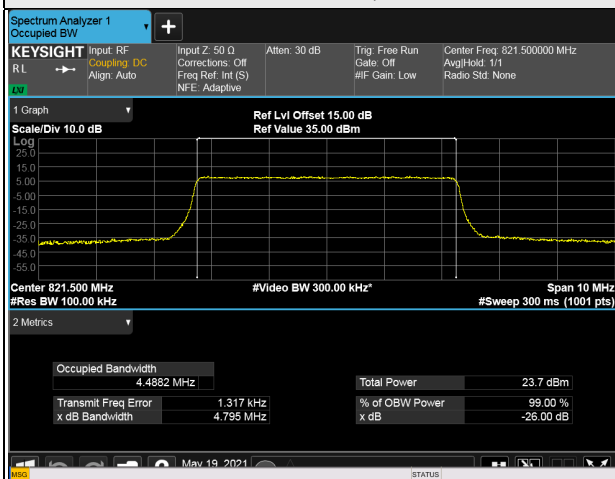

10MHz / 64QAM

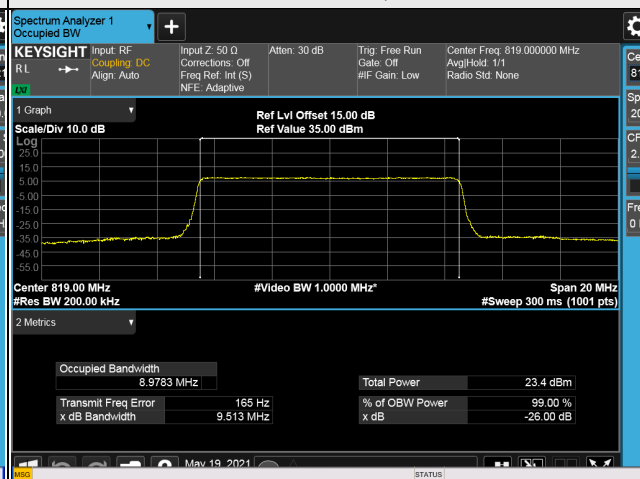

4.5 Emission Mask Measurement

4.5.1 Limits of Emission Mask Measurement

According to FCC part 90.691 shall be tested the emission mask. For any frequency removed from the EA licensee's frequency block by up to and including 37.5 kHz, the power of any emission shall be attenuated below the transmitter power (P) in watts by at least $116 \text{ Log}_{10}(f/6.1)$ decibels or $50 + 10\text{Log}_{10}(P)$ decibels or 80 decibels, whichever is the lesser attenuation, where f is the frequency removed from the center of the outer channel in the block in kilohertz and where f is greater than 12.5 kHz.

For any frequency removed from the EA licensee's frequency block greater than 37.5 kHz, the power of any emission shall be attenuated below the transmitter power (P) in watts by at least $43 + 10\text{Log}_{10}(P)$ decibels or 80 decibels, whichever is the lesser attenuation, where f is the frequency removed from the center of the outer channel in the block in kilohertz and where f is greater than 37.5 kHz.

For § 90.691(a), RBW=300 Hz for offset less than 37.5 kHz from channel edge and RBW=100 kHz for offsets greater than 37.5 kHz is allowed, tested in accordance with FCC KDB 971168 D02 section VIII.

4.5.2 Test Setup

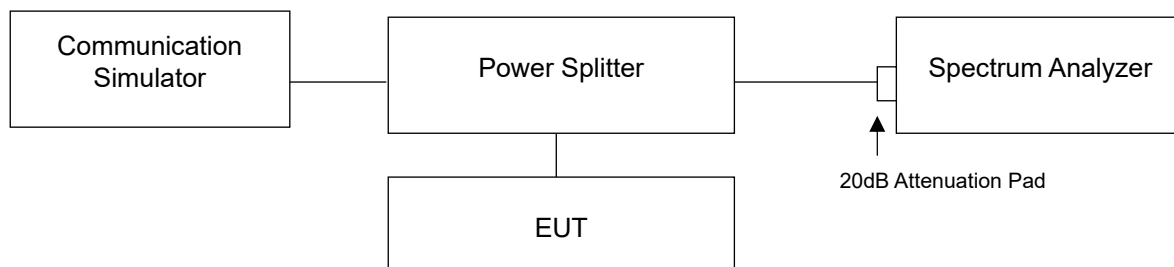

4.5.3 Test Procedures

- The measurement used the power splitter via EUT RF power connector between simulation base station and spectrum analyzer.
- Record the test plot.

4.5.4 Test Results



LTE Band 26, Channel Bandwidth 3MHz

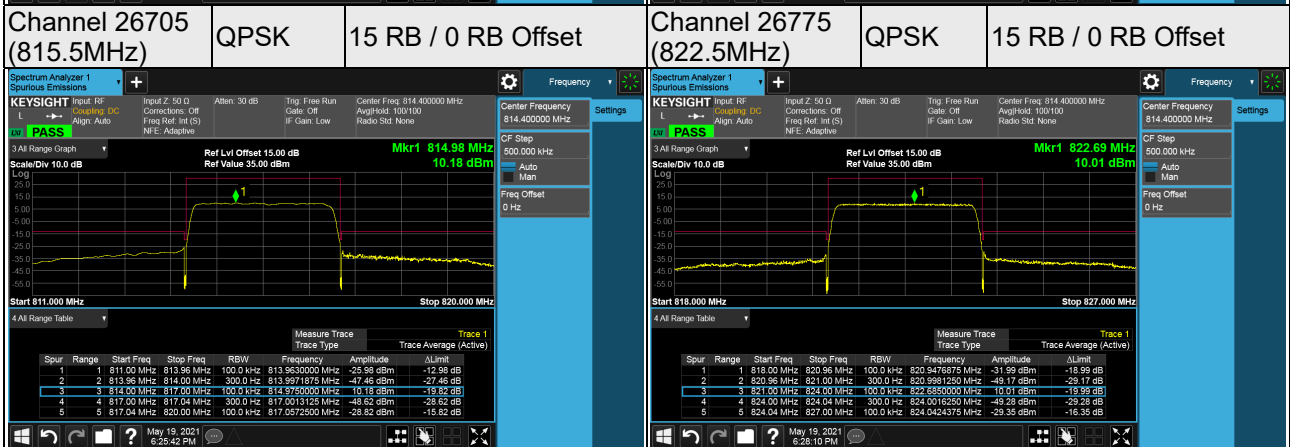
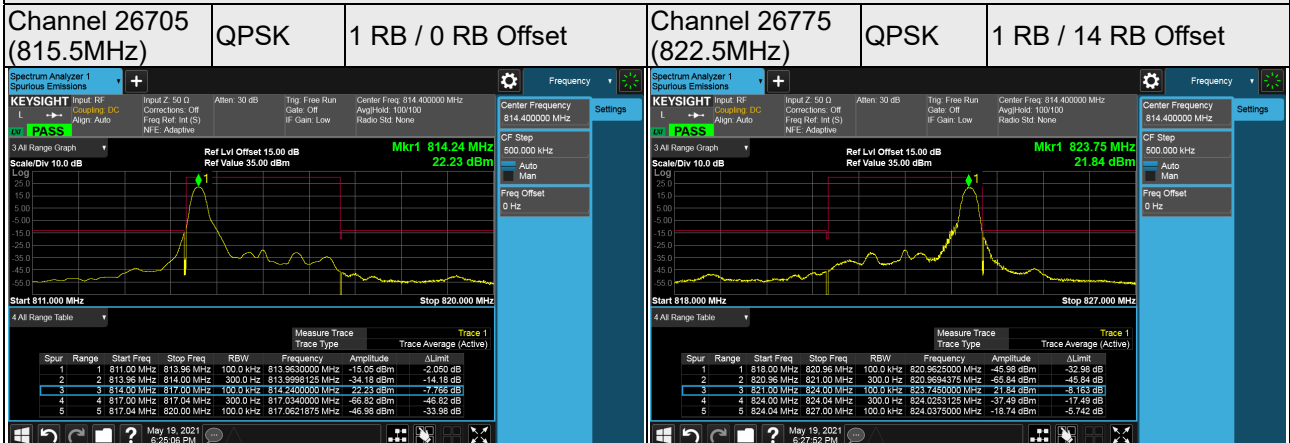

LTE Band 26, Channel Bandwidth 5MHz

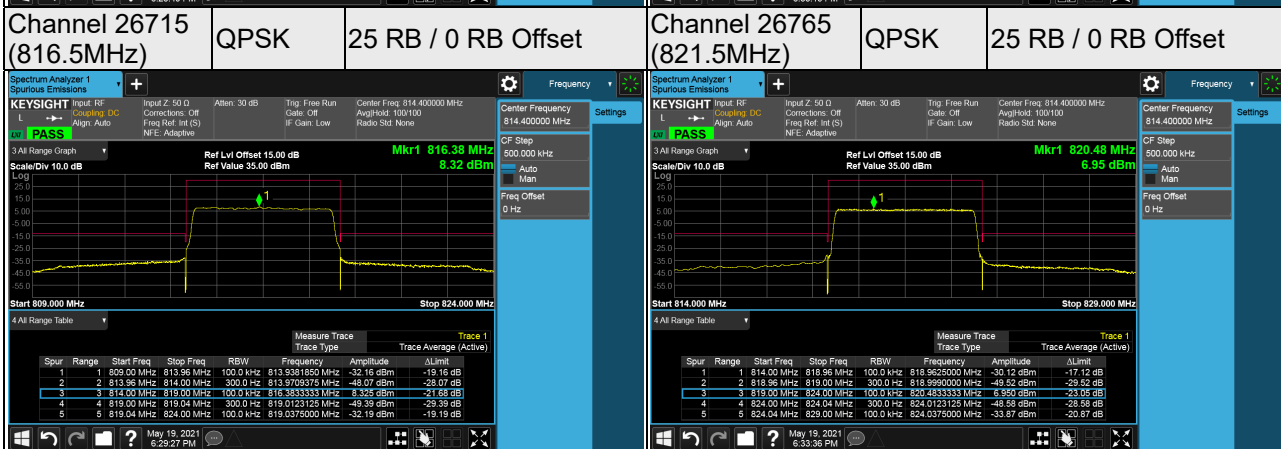
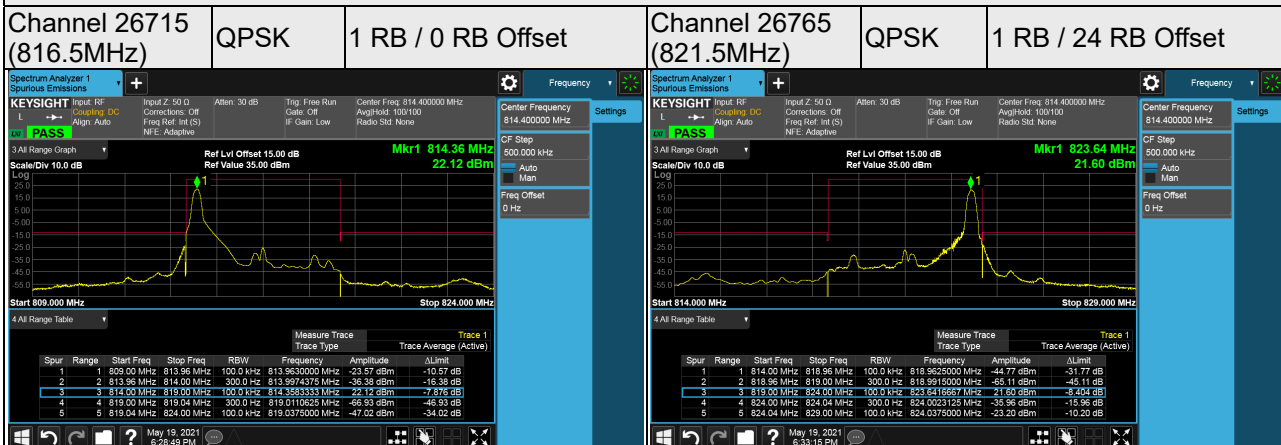

LTE Band 26, Channel Bandwidth 10MHz

Channel 26740 (819.0MHz)	QPSK	1 RB / 0 RB Offset	Channel 26740 (819.0MHz)	QPSK	1 RB / 49 RB Offset
-----------------------------	------	--------------------	-----------------------------	------	---------------------

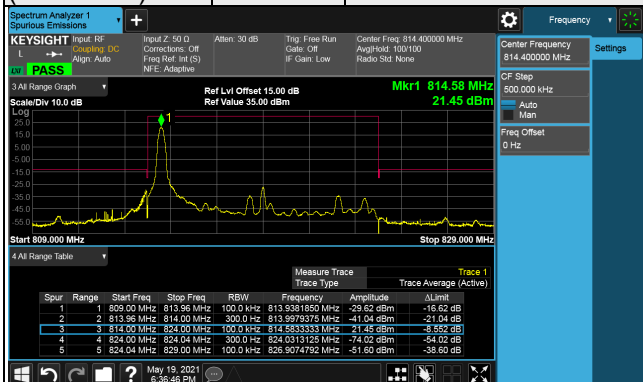

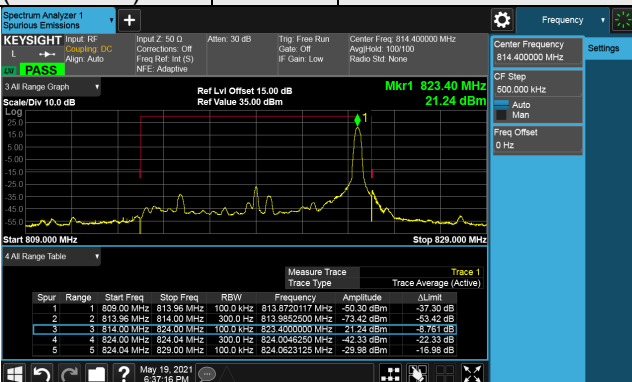

Channel 26740 (819.0MHz)	QPSK	50 RB / 0 RB Offset			
-----------------------------	------	---------------------	--	--	--

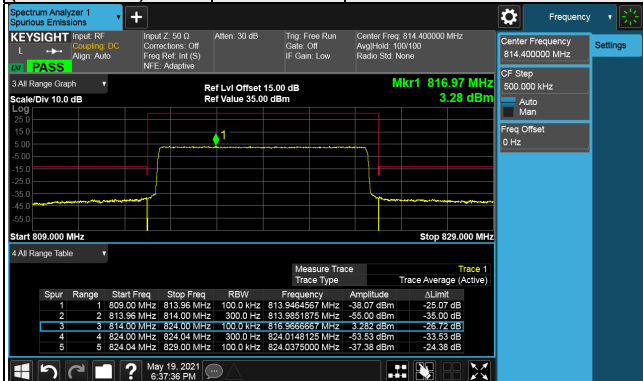

4.6 Conducted Spurious Emissions

4.6.1 Limits of Conducted Spurious Emissions Measurement

The power of any emission outside a licensee's frequency block shall be attenuated below the transmitter power (P) by at least $43 + 10 \log_{10}(P)$ dB. The limit of emission equal to -13dBm .

4.6.2 Test Setup

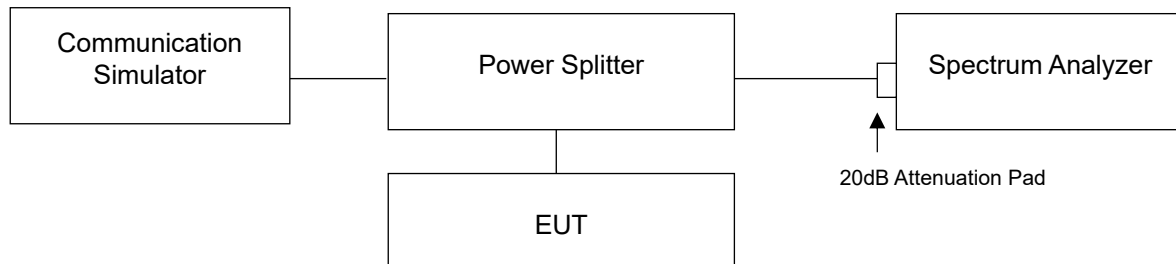

4.6.3 Test Procedure

- The EUT makes a phone call to the communication simulator. All measurements were done at low, middle and high operational frequency range.
- Measuring frequency range is from 9kHz to 9GHz. 20dB attenuation pad is connected with spectrum. RBW=100kHz and VBW=300kHz for 9kHz to 1GHz and RBW=1MHz and VBW=3MHz for 1 GHz to 9GHz are used for LTE band conducted emission measurement.

4.6.4 Test Results

LTE Band 26, Channel Bandwidth 1.4MHz

Channel 26697 (814.7MHz)

Frequency Range : 9kHz ~ 1GHz

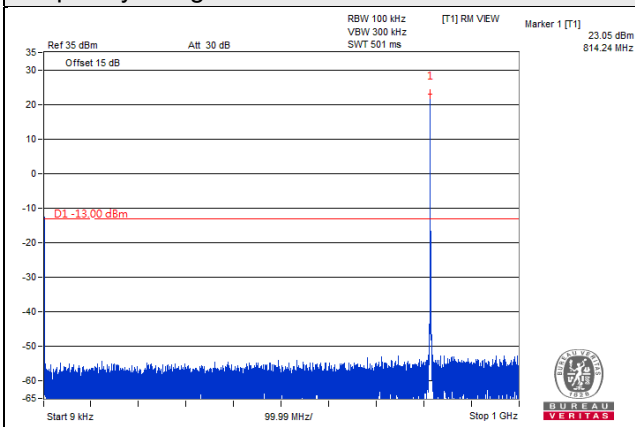

Frequency Range : 1GHz ~ 9GHz

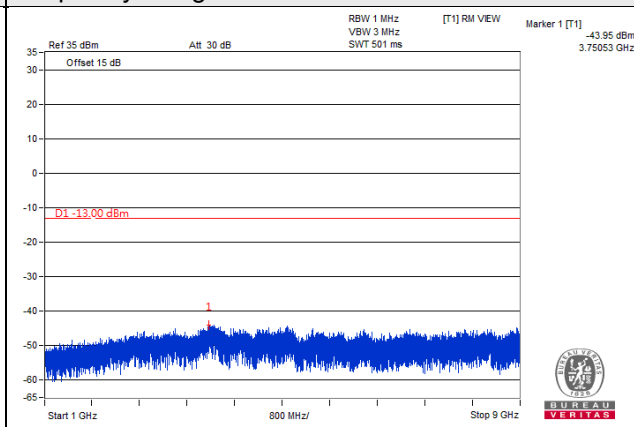

Channel 26740 (819.0MHz)

Frequency Range : 9kHz ~ 1GHz

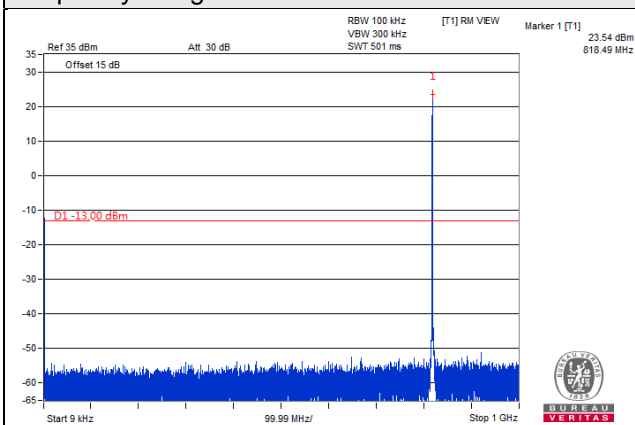

Frequency Range : 1GHz ~ 9GHz

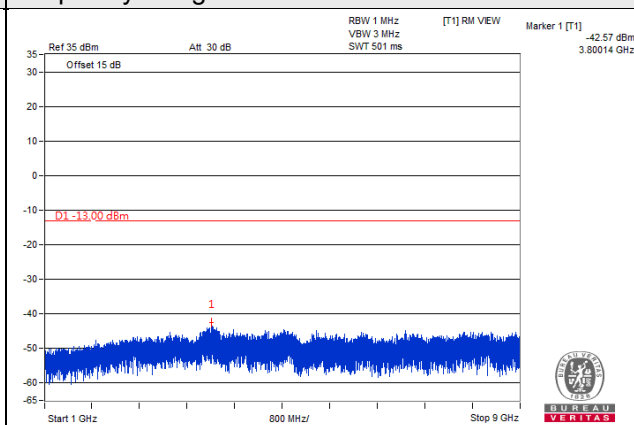

Channel 26783 (823.3MHz)

Frequency Range : 9kHz ~ 1GHz

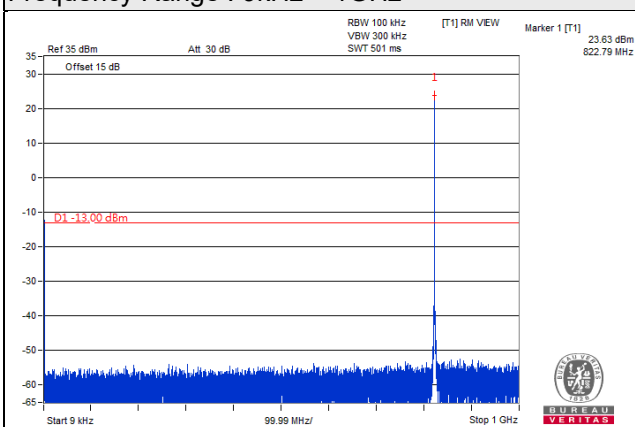

Frequency Range : 1GHz ~ 9GHz

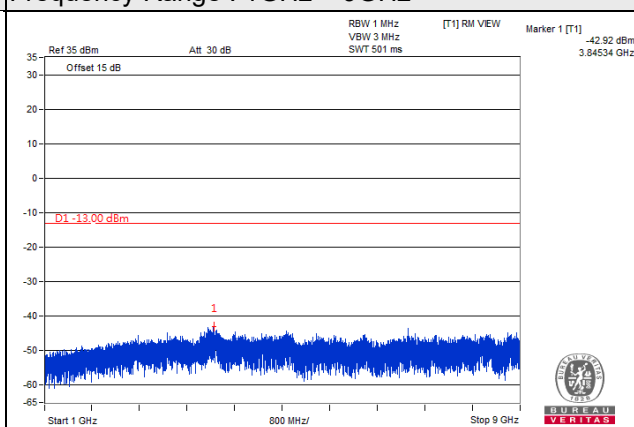

*The 9kHz signal over the limit is from Spectrum.

LTE Band 26, Channel Bandwidth 3MHz

Channel 26705 (815.5MHz)

Frequency Range : 9kHz ~ 1GHz

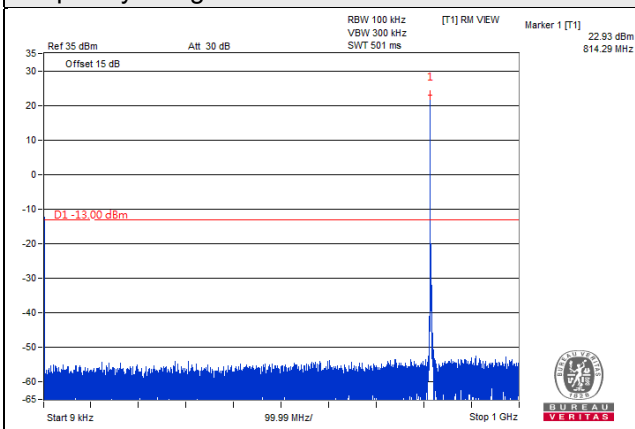

Frequency Range : 1GHz ~ 9GHz

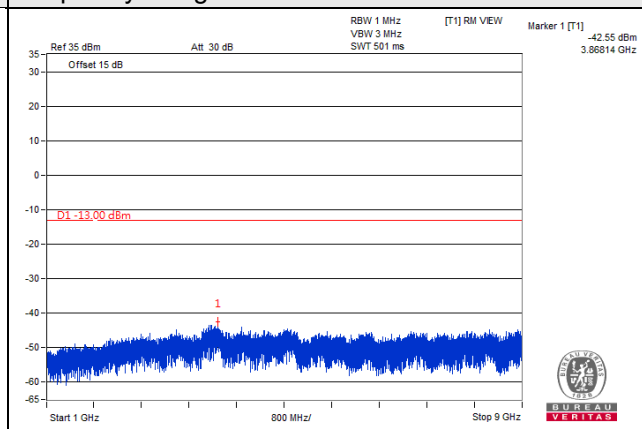

Channel 26740 (819.0MHz)

Frequency Range : 9kHz ~ 1GHz

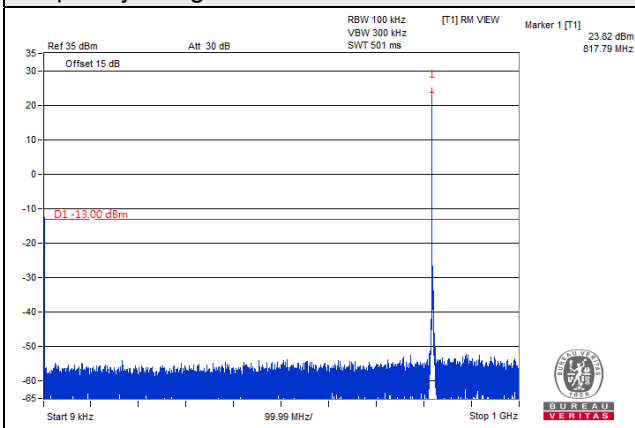

Frequency Range : 1GHz ~ 9GHz

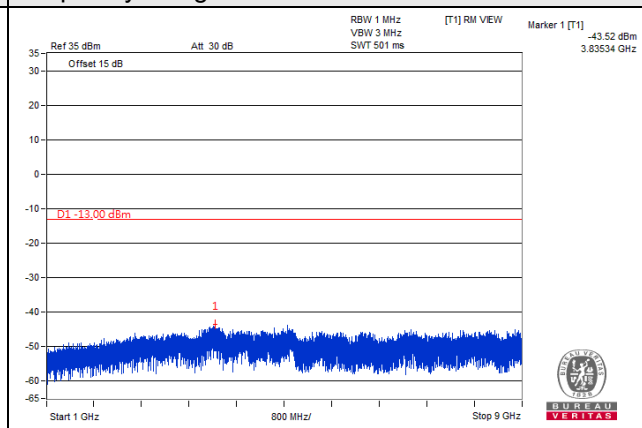

Channel 26775 (822.5MHz)

Frequency Range : 9kHz ~ 1GHz

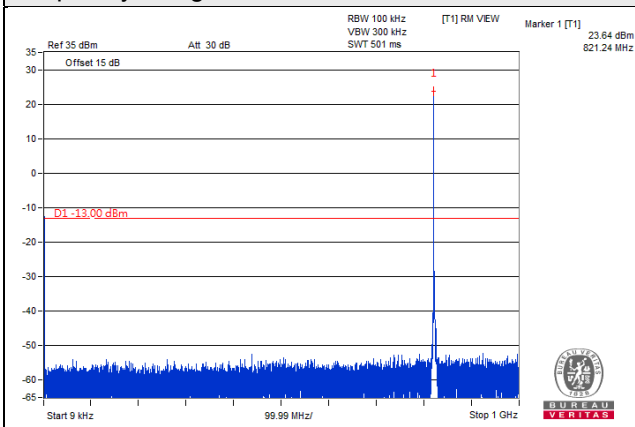

Frequency Range : 1GHz ~ 9GHz

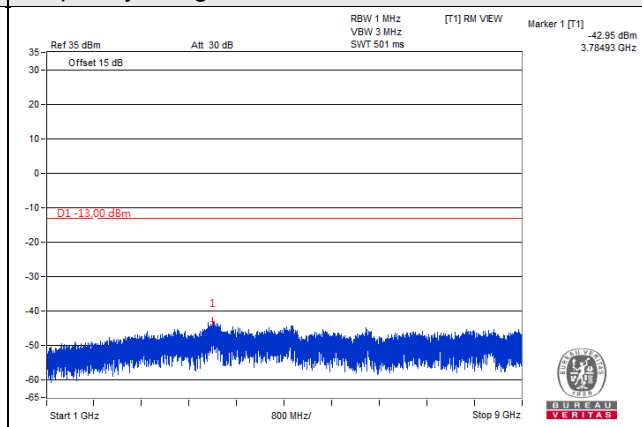

*The 9kHz signal over the limit is from Spectrum.

LTE Band 26, Channel Bandwidth 5MHz

Channel 26715 (816.5MHz)

Frequency Range : 9kHz ~ 1GHz

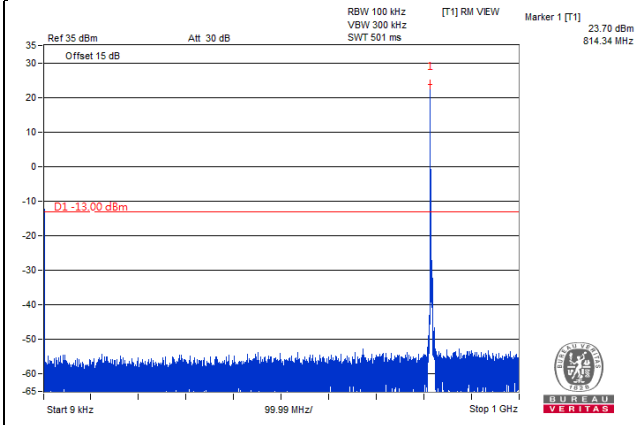

Frequency Range : 1GHz ~ 9GHz

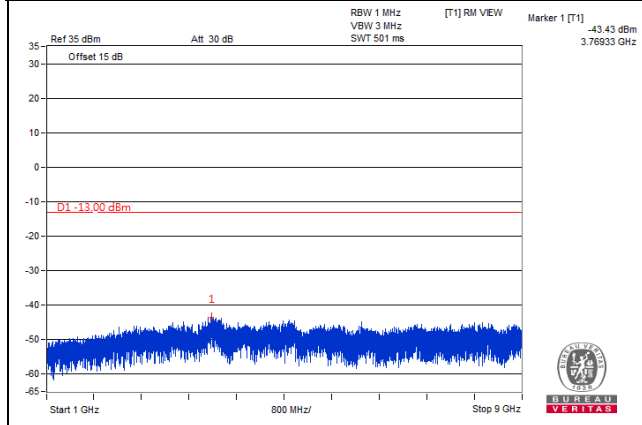

Channel 26740 (819.0MHz)

Frequency Range : 9kHz ~ 1GHz

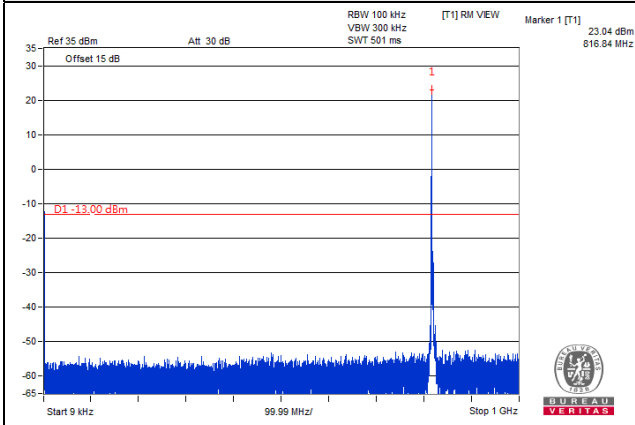

Frequency Range : 1GHz ~ 9GHz

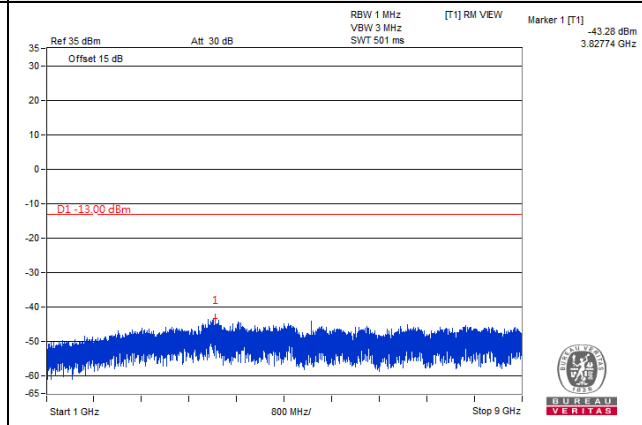

Channel 26765 (821.5MHz)

Frequency Range : 9kHz ~ 1GHz

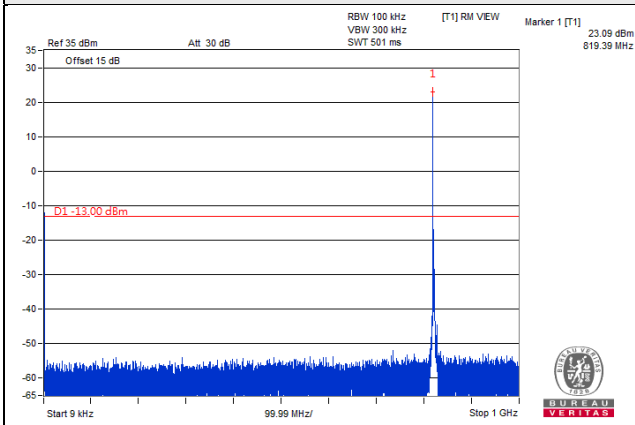

Frequency Range : 1GHz ~ 9GHz

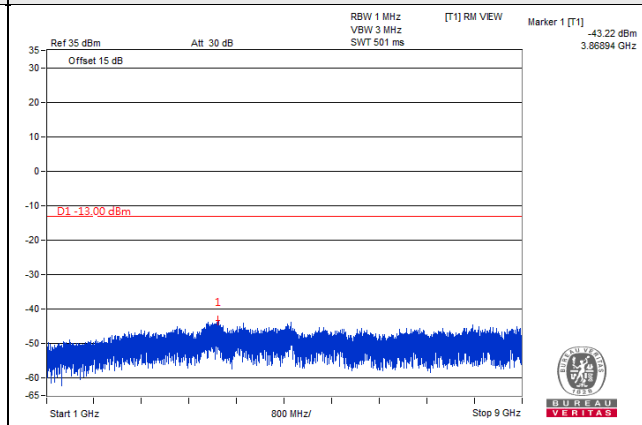

*The 9kHz signal over the limit is from Spectrum.

LTE Band 26, Channel Bandwidth 10MHz

Channel 26740 (819.0MHz)

Frequency Range : 9kHz ~ 1GHz

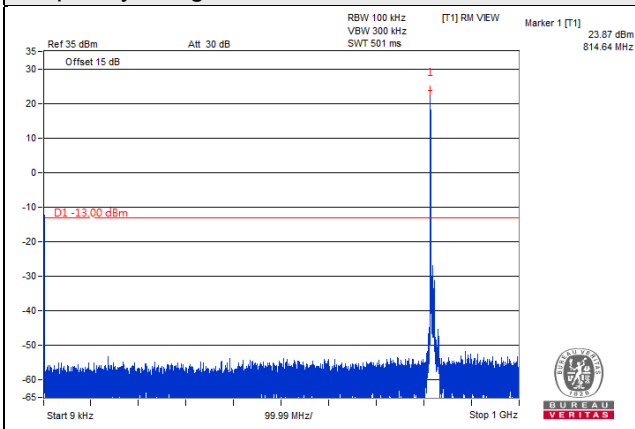

Frequency Range : 1GHz ~ 9GHz

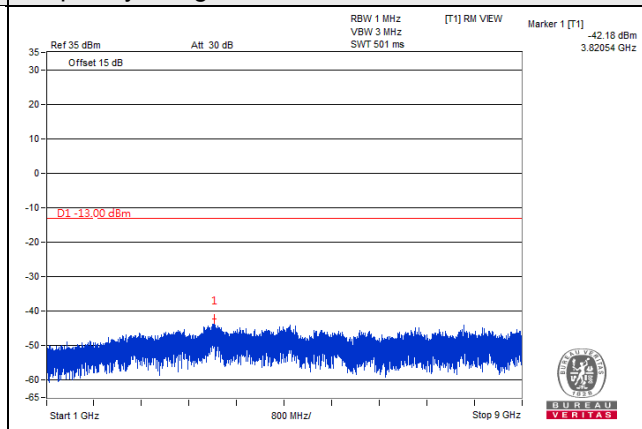

*The 9kHz signal over the limit is from Spectrum.

4.7 Radiated Emission Measurement

4.7.1 Limits of Radiated Emission Measurement

The power of any emission outside a licensee's frequency block shall be attenuated below the transmitter power (P) by at least $43 + 10 \log_{10}(P)$ dB. The limit of emission equal to -13 dBm.

4.7.2 Test Procedure

- a. Substitution method is used for E.I.R.P measurement. In the semi-anechoic chamber, EUT placed on the 0.8m(below or equal 1GHz) and/or 1.5m(above 1GHz) height of Turn Table, rotated the table around 360 degrees to search the maximum radiation power and receiver antenna shall be rotated vertical and horizontal polarization and moved height from 1m to 4m to find the maximum polar radiated power. The "Read Value" is the spectrum reading the maximum power value.
- b. The height of antenna is varied from one meter to four meters above the ground to determine the maximum value of the field strength. Both horizontal and vertical polarizations of the antenna are set to make the measurement.
- c. Perform a field strength measurement and record the worse read value, is the field strength value via a spectrum reading obtained corrected for antenna factor, cable loss and pre-amplifier factor and then mathematically convert the measured field strength level to EIRP/ERP level.
- d. Following C63.26 section 5.5 and 5.2.7
 - $EIRP (dBm) = E (dB\mu V/m) + 20\log(D) - 104.8$; where D is the measurement distance (in the far field region) in m.
 - $ERP (dBm) = E (dB\mu V/m) + 20\log(D) - 104.8 - 2.15$; where D is the measurement distance (in the far field region) in m.

Note:

1. The resolution bandwidth and video bandwidth of test receiver/spectrum analyzer is 1MHz/3MHz.
2. The emission levels were against the limit of frequency range 9 kHz ~ 30 MHz:
The amplitude of spurious emissions attenuated more than 20 dB below the permissible value is not required to be report.

4.7.3 Deviation from Test Standard

No deviation.

4.7.4 Test Setup

For radiated emission 30MHz to 1GHz

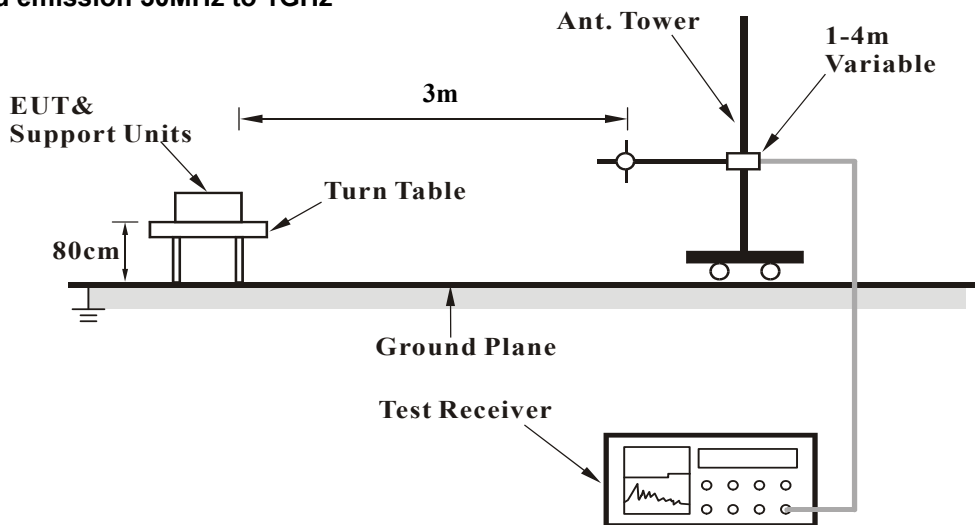

For radiated emission above 1GHz

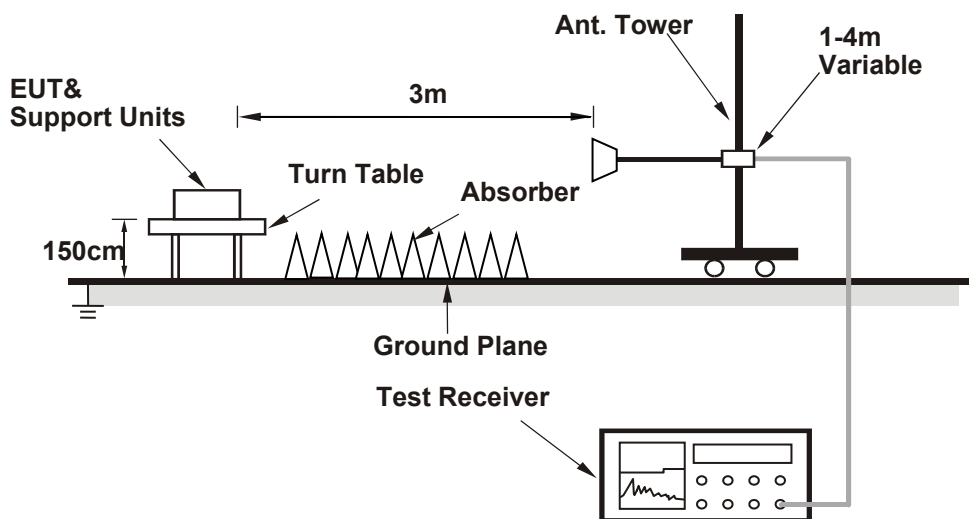

For the actual test configuration, please refer to the attached file (Test Setup Photo).

4.7.5 Test Results

Below 1GHz

LTE Band 26, Channel Bandwidth 5MHz

Mode	TX channel 26740 (819.0MHz)	Frequency Range	Below 1000 MHz
Environmental Conditions	25deg. C, 70%RH	Input Power	120Vac, 60Hz
Tested By	Edison Lee		

Antenna Polarity & Test Distance : Horizontal at 3 m								
No	Frequency (MHz)	ERP (dBm)	Limit (dBm)	Margin (dB)	Antenna Height (m)	Table Angle (Degree)	Raw Value (dBuV)	Correction Factor (dB/m)
1	51.09	-65.60	-13.00	-52.60	1.00 H	125	40.90	-106.50
2	80.61	-66.70	-13.00	-53.70	1.49 H	281	44.30	-111.00
3	183.23	-67.00	-13.00	-54.00	1.49 H	231	40.70	-107.70
4	263.36	-65.40	-13.00	-52.40	1.00 H	30	39.80	-105.20
5	361.77	-71.70	-13.00	-58.70	1.49 H	151	31.20	-102.90
6	723.06	-69.20	-13.00	-56.20	1.49 H	107	25.90	-95.10

Remarks:

1. $ERP(dBm) = Raw\ Value(dBuV) + Correction\ Factor(dB/m)$.
2. $Correction\ Factor(dB/m) = Antenna\ Factor(dB/m) + Cable\ Factor(dB) - Pre-Amplifier\ Factor(dB) + 20\log(D) - 104.8 - 2.15$
3. $Margin\ value = ERP - Limit\ value$.
4. The other ERP levels were very low against the limit.

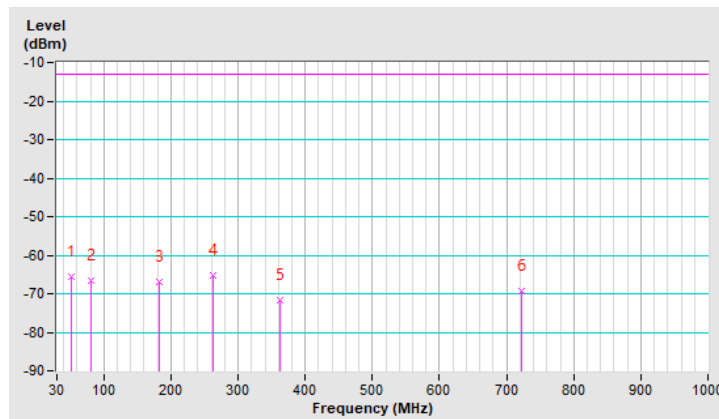

Mode	TX channel 26740 (819.0MHz)	Frequency Range	Below 1000 MHz
Environmental Conditions	25deg. C, 70%RH	Input Power	120Vac, 60Hz
Tested By	Edison Lee		

Antenna Polarity & Test Distance : Vertical at 3m								
No	Frequency (MHz)	ERP (dBm)	Limit (dBm)	Margin (dB)	Antenna Height (m)	Table Angle (Degree)	Raw Value (dBuV)	Correction Factor (dB/m)
1	51.09	-45.70	-13.00	-32.70	2.00 V	289	60.80	-106.50
2	80.61	-51.30	-13.00	-38.30	1.00 V	121	59.70	-111.00
3	103.10	-55.10	-13.00	-42.10	2.00 V	58	55.10	-110.20
4	364.58	-61.90	-13.00	-48.90	1.00 V	111	40.70	-102.60
5	429.25	-67.50	-13.00	-54.50	1.49 V	168	33.70	-101.20
6	572.64	-67.70	-13.00	-54.70	1.50 V	126	30.50	-98.20

Remarks:

1. $ERP(dBm) = Raw\ Value(dBuV) + Correction\ Factor(dB/m)$.
2. $Correction\ Factor(dB/m) = Antenna\ Factor(dB/m) + Cable\ Factor(dB) - Pre-Amplifier\ Factor(dB) + 20\log(D) - 104.8 - 2.15$
3. Margin value = ERP – Limit value.
4. The other ERP levels were very low against the limit.

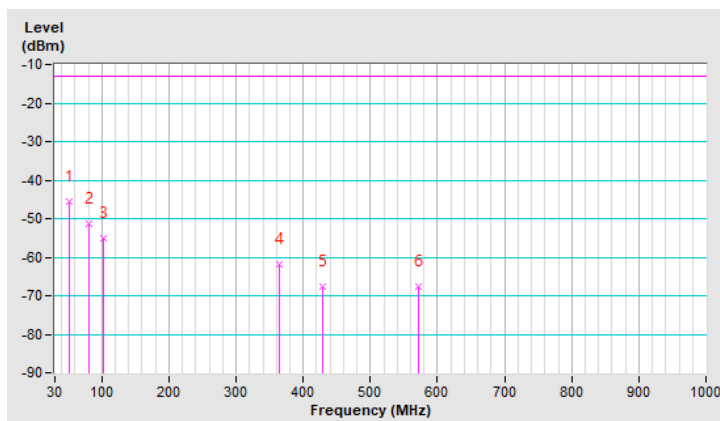

Above 1GHz

LTE Band 26, Channel Bandwidth 1.4MHz

Mode	TX channel 26697 (814.7MHz)	Frequency Range	1GHz ~ 9GHz
Environmental Conditions	25deg. C, 70%RH	Input Power	120Vac, 60Hz
Tested By	Edison Lee		

Antenna Polarity & Test Distance : Horizontal at 3 m								
No	Frequency (MHz)	ERP (dBm)	Limit (dBm)	Margin (dB)	Antenna Height (m)	Table Angle (Degree)	Raw Value (dBuV)	Correction Factor (dB/m)
1	1629.40	-58.50	-13.00	-45.50	2.63 H	31	44.30	-102.80
Antenna Polarity & Test Distance : Vertical at 3m								
No	Frequency (MHz)	ERP (dBm)	Limit (dBm)	Margin (dB)	Antenna Height (m)	Table Angle (Degree)	Raw Value (dBuV)	Correction Factor (dB/m)
1	1629.40	-57.10	-13.00	-44.10	1.88 V	345	45.70	-102.80

Remarks:

1. $ERP(dBm) = Raw\ Value(dBuV) + Correction\ Factor(dB/m)$.
2. $Correction\ Factor(dB/m) = Antenna\ Factor(dB/m) + Cable\ Factor(dB) - Pre-Amplifier\ Factor(dB) + 20\log(D) - 104.8 - 2.15$
3. Margin value = ERP – Limit value.
4. The other ERP levels were very low against the limit.

Mode	TX channel 26740 (819.0MHz)	Frequency Range	1GHz ~ 9GHz
Environmental Conditions	25deg. C, 70%RH	Input Power	120Vac, 60Hz
Tested By	Edison Lee		

Antenna Polarity & Test Distance : Horizontal at 3 m								
No	Frequency (MHz)	ERP (dBm)	Limit (dBm)	Margin (dB)	Antenna Height (m)	Table Angle (Degree)	Raw Value (dBuV)	Correction Factor (dB/m)
1	1638.00	-60.10	-13.00	-47.10	2.67 H	43	42.70	-102.80
Antenna Polarity & Test Distance : Vertical at 3m								
No	Frequency (MHz)	ERP (dBm)	Limit (dBm)	Margin (dB)	Antenna Height (m)	Table Angle (Degree)	Raw Value (dBuV)	Correction Factor (dB/m)
1	1638.00	-57.50	-13.00	-44.50	1.90 V	359	45.30	-102.80

Remarks:

1. $ERP(dBm) = Raw\ Value(dBuV) + Correction\ Factor(dB/m)$.
2. $Correction\ Factor(dB/m) = Antenna\ Factor(dB/m) + Cable\ Factor(dB) - Pre-Amplifier\ Factor(dB) + 20\log(D) - 104.8 - 2.15$
3. Margin value = ERP – Limit value.
4. The other ERP levels were very low against the limit.

Mode	TX channel 26783 (823.3MHz)	Frequency Range	1GHz ~ 9GHz
Environmental Conditions	25deg. C, 70%RH	Input Power	120Vac, 60Hz
Tested By	Edison Lee		

Antenna Polarity & Test Distance : Horizontal at 3 m								
No	Frequency (MHz)	ERP (dBm)	Limit (dBm)	Margin (dB)	Antenna Height (m)	Table Angle (Degree)	Raw Value (dBuV)	Correction Factor (dB/m)
1	1646.60	-59.40	-13.00	-46.40	2.54 H	17	43.10	-102.50
Antenna Polarity & Test Distance : Vertical at 3m								
No	Frequency (MHz)	ERP (dBm)	Limit (dBm)	Margin (dB)	Antenna Height (m)	Table Angle (Degree)	Raw Value (dBuV)	Correction Factor (dB/m)
1	1646.60	-56.60	-13.00	-43.60	1.79 V	338	45.90	-102.50

Remarks:

1. $ERP(dBm) = Raw\ Value(dBuV) + Correction\ Factor(dB/m)$.
2. $Correction\ Factor(dB/m) = Antenna\ Factor(dB/m) + Cable\ Factor(dB) - Pre-Amplifier\ Factor(dB) + 20\log(D) - 104.8 - 2.15$
3. Margin value = ERP – Limit value.
4. The other ERP levels were very low against the limit.

LTE Band 26, Channel Bandwidth 5MHz

Mode	TX channel 26715 (816.5MHz)	Frequency Range	1GHz ~ 9GHz
Environmental Conditions	25deg. C, 70%RH	Input Power	120Vac, 60Hz
Tested By	Edison Lee		

Antenna Polarity & Test Distance : Horizontal at 3 m								
No	Frequency (MHz)	ERP (dBm)	Limit (dBm)	Margin (dB)	Antenna Height (m)	Table Angle (Degree)	Raw Value (dBuV)	Correction Factor (dB/m)
1	1633.00	-58.90	-13.00	-45.90	2.40 H	18	43.90	-102.80
Antenna Polarity & Test Distance : Vertical at 3m								
No	Frequency (MHz)	ERP (dBm)	Limit (dBm)	Margin (dB)	Antenna Height (m)	Table Angle (Degree)	Raw Value (dBuV)	Correction Factor (dB/m)
1	1633.00	-56.90	-13.00	-43.90	1.88 V	337	45.90	-102.80

Remarks:

1. $ERP(dBm) = Raw\ Value(dBuV) + Correction\ Factor(dB/m)$.
2. $Correction\ Factor(dB/m) = Antenna\ Factor(dB/m) + Cable\ Factor(dB) - Pre-Amplifier\ Factor(dB) + 20\log(D) - 104.8 - 2.15$
3. Margin value = ERP – Limit value.
4. The other ERP levels were very low against the limit.

Mode	TX channel 26740 (819.0MHz)	Frequency Range	1GHz ~ 9GHz
Environmental Conditions	25deg. C, 70%RH	Input Power	120Vac, 60Hz
Tested By	Edison Lee		

Antenna Polarity & Test Distance : Horizontal at 3 m								
No	Frequency (MHz)	ERP (dBm)	Limit (dBm)	Margin (dB)	Antenna Height (m)	Table Angle (Degree)	Raw Value (dBuV)	Correction Factor (dB/m)
1	1638.00	-58.50	-13.00	-45.50	2.56 H	22	44.30	-102.80
Antenna Polarity & Test Distance : Vertical at 3m								
No	Frequency (MHz)	ERP (dBm)	Limit (dBm)	Margin (dB)	Antenna Height (m)	Table Angle (Degree)	Raw Value (dBuV)	Correction Factor (dB/m)
1	1638.00	-56.50	-13.00	-43.50	1.65 V	337	46.30	-102.80

Remarks:

1. $ERP(dBm) = Raw\ Value(dBuV) + Correction\ Factor(dB/m)$.
2. $Correction\ Factor(dB/m) = Antenna\ Factor(dB/m) + Cable\ Factor(dB) - Pre-Amplifier\ Factor(dB) + 20\log(D) - 104.8 - 2.15$
3. Margin value = ERP – Limit value.
4. The other ERP levels were very low against the limit.

Mode	TX channel 26765 (821.5MHz)	Frequency Range	1GHz ~ 9GHz
Environmental Conditions	25deg. C, 70%RH	Input Power	120Vac, 60Hz
Tested By	Edison Lee		

Antenna Polarity & Test Distance : Horizontal at 3 m								
No	Frequency (MHz)	ERP (dBm)	Limit (dBm)	Margin (dB)	Antenna Height (m)	Table Angle (Degree)	Raw Value (dBuV)	Correction Factor (dB/m)
1	1643.00	-59.10	-13.00	-46.10	2.71 H	30	43.50	-102.60
Antenna Polarity & Test Distance : Vertical at 3m								
No	Frequency (MHz)	ERP (dBm)	Limit (dBm)	Margin (dB)	Antenna Height (m)	Table Angle (Degree)	Raw Value (dBuV)	Correction Factor (dB/m)
1	1643.00	-56.50	-13.00	-43.50	1.69 V	351	46.10	-102.60

Remarks:

1. $ERP(dBm) = Raw\ Value(dBuV) + Correction\ Factor(dB/m)$.
2. $Correction\ Factor(dB/m) = Antenna\ Factor(dB/m) + Cable\ Factor(dB) - Pre-Amplifier\ Factor(dB) + 20\log(D) - 104.8 - 2.15$
3. Margin value = ERP – Limit value.
4. The other ERP levels were very low against the limit.

LTE Band 26, Channel Bandwidth 10MHz

Mode	TX channel 26740 (819.0MHz)	Frequency Range	1GHz ~ 9GHz
Environmental Conditions	25deg. C, 70%RH	Input Power	120Vac, 60Hz
Tested By	Edison Lee		

Antenna Polarity & Test Distance : Horizontal at 3 m								
No	Frequency (MHz)	ERP (dBm)	Limit (dBm)	Margin (dB)	Antenna Height (m)	Table Angle (Degree)	Raw Value (dBuV)	Correction Factor (dB/m)
1	1638.00	-58.60	-13.00	-45.60	2.66 H	46	44.20	-102.80
Antenna Polarity & Test Distance : Vertical at 3m								
No	Frequency (MHz)	ERP (dBm)	Limit (dBm)	Margin (dB)	Antenna Height (m)	Table Angle (Degree)	Raw Value (dBuV)	Correction Factor (dB/m)
1	1638.00	-57.00	-13.00	-44.00	1.71 V	332	45.80	-102.80

Remarks:

1. $ERP(dBm) = Raw\ Value(dBuV) + Correction\ Factor(dB/m)$.
2. $Correction\ Factor(dB/m) = Antenna\ Factor(dB/m) + Cable\ Factor(dB) - Pre-Amplifier\ Factor(dB) + 20\log(D) - 104.8 - 2.15$
3. Margin value = ERP – Limit value.
4. The other ERP levels were very low against the limit.

5 Pictures of Test Arrangements

Please refer to the attached file (Test Setup Photo).

Appendix – Information of the Testing Laboratories

We, Bureau Veritas Consumer Products Services (H.K.) Ltd., Taoyuan Branch, were founded in 1988 to provide our best service in EMC, Radio, Telecom and Safety consultation. Our laboratories are FCC recognized accredited test firms and accredited and approved according to ISO/IEC 17025.

If you have any comments, please feel free to contact us at the following:

Linko EMC/RF Lab

Tel: 886-2-26052180
Fax: 886-2-26051924

Hsin Chu EMC/RF/Telecom Lab

Tel: 886-3-6668565
Fax: 886-3-6668323

Hwa Ya EMC/RF/Safety Lab

Tel: 886-3-3183232
Fax: 886-3-3270892

Email: service.adt@tw.bureauveritas.com

Web Site: www.bureauveritas-adt.com

The address and road map of all our labs can be found in our web site also.

--- END ---