

FCC Radio Test Report

FCC ID: HFSQTA-TP00126A

Report No. : BTL-FCCP-4-2006T132
Equipment : Notebook Computer
Model Name : TP00126A, Lenovo ThinkPad C13 Yoga Gen 1 Chromebook*****
(x=0~9, A~z, "-" or blank)
Brand Name : Lenovo
Applicant : Quanta Computer Inc.
Address : No. 188, Wenhua 2nd Rd., Guishan Dist., Taoyuan City 33377, Taiwan
Manufacturer : Quanta Computer Inc.
Address : No. 188, Wenhua 2nd Rd., Guishan Dist., Taoyuan City 33377, Taiwan

Radio Function : RLAN 5 GHz (U-NII 1, U-NII 2A, U-NII 2C, U-NII 3)

FCC Rule Part(s) : FCC Part15, Subpart E (15.407)
Measurement Procedure(s) : ANSI C63.10-2013

Date of Receipt : 2020/6/24
Date of Test : 2020/6/24 ~ 2020/7/30
Issued Date : 2020/10/7

The above equipment has been tested and found in compliance with the requirement of the above standards by BTL Inc.

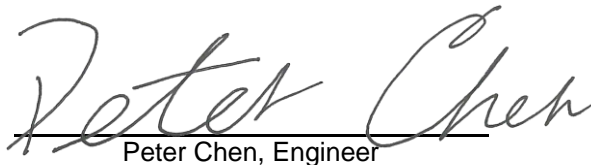
Prepared by :
Peter Chen, Engineer**Approved by** :
Scott Hsu, Manager**BTL Inc.**

No.18, Ln. 171, Sec. 2, Jiuzong Rd., Neihu Dist., Taipei City 114, Taiwan

Tel: +886-2-2657-3299

Fax: +886-2-2657-3331

Web: www.newbtl.com

Declaration

BTL represents to the client that testing is done in accordance with standard procedures as applicable and that test instruments used has been calibrated with standards traceable to international standard(s) and/or national standard(s).

BTL's reports apply only to the specific samples tested under conditions. It is manufacture's responsibility to ensure that additional production units of this model are manufactured with the identical electrical and mechanical components. **BTL** shall have no liability for any declarations, inferences or generalizations drawn by the client or others from **BTL** issued reports.

The report must not be used by the client to claim product certification, approval, or endorsement by NIST, A2LA, or any agency of the U.S. Government.

This report is the confidential property of the client. As a mutual protection to the clients, the public and ourselves, the test report shall not be reproduced, except in full, without our written approval.

BTL's laboratory quality assurance procedures are in compliance with the **ISO/IEC 17025** requirements, and accredited by the conformity assessment authorities listed in this test report.

BTL is not responsible for the sampling stage, so the results only apply to the sample as received.

The information, data and test plan are provided by manufacturer which may affect the validity of results, so it is manufacturer's responsibility to ensure that the apparatus meets the essential requirements of applied standards and in all the possible configurations as representative of its intended use.

Limitation

For the use of the authority's logo is limited unless the Test Standard(s)/Scope(s)/Item(s) mentioned in this test report is (are) included in the conformity assessment authorities acceptance respective.

Please note that the measurement uncertainty is provided for informational purpose only and are not use in determining the Pass/Fail results.

CONTENTS

REPORT ISSUED HISTORY	5
1 SUMMARY OF TEST RESULTS	6
1.1 TEST FACILITY	7
1.2 MEASUREMENT UNCERTAINTY	7
1.3 TEST ENVIRONMENT CONDITIONS	7
1.4 TABLE OF PARAMETERS OF TEST SOFTWARE SETTING	8
1.5 DUTY CYCLE	10
2 GENERAL INFORMATION	13
2.1 DESCRIPTION OF EUT	13
2.2 TEST MODES	18
2.3 BLOCK DIAGRAM SHOWING THE CONFIGURATION OF SYSTEM TESTED	20
2.4 SUPPORT UNITS	20
3 AC POWER LINE CONDUCTED EMISSIONS TEST	21
3.1 LIMIT	21
3.2 TEST PROCEDURE	21
3.3 DEVIATION FROM TEST STANDARD	21
3.4 TEST SETUP	22
3.5 TEST RESULT	22
4 RADIATED EMISSIONS TEST	23
4.1 LIMIT	23
4.2 TEST PROCEDURE	24
4.3 DEVIATION FROM TEST STANDARD	24
4.4 TEST SETUP	25
4.5 EUT OPERATING CONDITIONS	26
4.6 TEST RESULT – 30 MHZ TO 1 GHZ	26
4.7 TEST RESULT – ABOVE 1 GHZ	26
5 BANDWIDTH TEST	27
5.1 LIMIT	27
5.2 TEST PROCEDURE	27
5.3 DEVIATION FROM TEST STANDARD	27
5.4 TEST SETUP	27
5.5 EUT OPERATING CONDITIONS	27
5.6 TEST RESULT	27
6 OUTPUT POWER TEST	28
6.1 LIMIT	28
6.2 TEST PROCEDURE	28
6.3 DEVIATION FROM TEST STANDARD	28
6.4 TEST SETUP	28
6.5 EUT OPERATING CONDITIONS	28
6.6 TEST RESULT	28
7 POWER SPECTRAL DENSITY	29
7.1 LIMIT	29
7.2 TEST PROCEDURE	29
7.3 DEVIATION FROM TEST STANDARD	29
7.4 TEST SETUP	29
7.5 EUT OPERATING CONDITIONS	29
7.6 TEST RESULT	29

8	LIST OF MEASURING EQUIPMENTS	30
9	EUT TEST PHOTO	31
10	EUT PHOTOS	31
APPENDIX A	AC POWER LINE CONDUCTED EMISSIONS	32
APPENDIX B	RADIATED EMISSIONS - 30 MHZ TO 1 GHZ	37
APPENDIX C	RADIATED EMISSIONS - ABOVE 1 GHZ	40
APPENDIX D	BANDWIDTH	231
APPENDIX E	CONDUCTED OUTPUT POWER	278
APPENDIX F	POWER SPECTRAL DENSITY	302

REPORT ISSUED HISTORY

Report Version	Description	Issued Date
R00	Original Issue.	2020/8/11
R01	Revised typo.	2020/8/28
R02	Revised report to address TCB's comments.	2020/9/14
R03	Revised report to address TCB's comments.	2020/10/7

1 SUMMARY OF TEST RESULTS

Test procedures according to the technical standards.

FCC Part 15, Subpart E (15.407)				
Standard(s) Section	Description	Test Result	Judgement	Remark
15.207	AC Power Line Conducted Emissions	APPENDIX A	Pass	-----
15.205 15.209 15.407(b)	Radiated Emissions	APPENDIX B APPENDIX C	Pass	-----
15.407(a)	Bandwidth	APPENDIX D	Pass	-----
15.407(a)	Output Power	APPENDIX E	Pass	-----
15.407(a)	Power Spectral Density	APPENDIX F	Pass	-----
15.203	Antenna Requirement	-----	Pass	-----
15.407(c)	Automatically Discontinue Transmission	-----	Pass	NOTE (3)

NOTE:

- (1) "N/A" denotes test is not applicable in this Test Report.
- (2) The report format version is TP.1.1.1.
- (3) The EUT can detect the controlling signal of ACK message transmitting from remote device and verify whether it shall resend or discontinue transmission.

1.1 TEST FACILITY

The test facilities used to collect the test data in this report:

No. 68-1, Ln. 169, Sec. 2, Datong Rd., Xizhi Dist., New Taipei City 221, Taiwan

The test sites and facilities are covered under FCC RN: 674415 and DN: TW0659.

- C05 CB08 CB11 CB15 CB16
 SR06

1.2 MEASUREMENT UNCERTAINTY

The reported uncertainty of measurement $y \pm U$, where expanded uncertainty U is based on a standard uncertainty multiplied by a coverage factor of $k = 2$, providing a level of confidence of approximately **95 %**. The measurement instrumentation uncertainty considerations contained in CISPR 16-4-2. The BTL measurement uncertainty is less than the CISPR 16-4-2 U_{cispr} requirement.

A. AC power line conducted emissions test:

Test Site	Method	Measurement Frequency Range	U (dB)
C05	CISPR	150 kHz ~ 30MHz	3.44

B. Radiated emissions test :

Test Site	Measurement Frequency Range	U,(dB)
CB15	0.03 GHz ~ 0.2 GHz	4.17
	0.2 GHz ~ 1 GHz	4.72
	1 GHz ~ 6 GHz	5.21
	6 GHz ~ 18 GHz	5.51
	18 GHz ~ 26 GHz	3.69
	26 GHz ~ 40 GHz	4.23

C. Conducted test :

Test Item	U,(dB)
Bandwidth	1.13
Output power	1.07
Power Spectral Density	1.20
Conducted Band edges	1.13
Frequency Stability	1.13

NOTE:

Unless specifically mentioned, the uncertainty of measurement has not been taken into account to declare the compliance or non-compliance to the specification.

1.3 TEST ENVIRONMENT CONDITIONS

Test Item	Environment Condition	Test Voltage	Tested by
AC Power Line Conducted Emissions	24 °C, 57 %	AC 120V	William Wei
Radiated emissions below 1 GHz	22 °C, 61 %	AC 120V	John Chuang
Radiated emissions above 1 GHz	22 °C, 60~61 %	AC 120V	John Chuang
Bandwidth	23.4 °C, 50 %	AC 120V	Tim Lee
Output Power	23.4 °C, 50 %	AC 120V	Tim Lee
Power Spectral Density	23.4 °C, 50 %	AC 120V	Tim Lee

1.4 TABLE OF PARAMETERS OF TEST SOFTWARE SETTING

UNII-1				
Test Software	DRTU V12.1947.0-10428			
Mode	5180 MHz	5200 MHz	5240 MHz	Data Rate
IEEE 802.11a	12.25	12.375	12.25	6 Mbps
IEEE 802.11n (HT20)	9.5	9.5	9.375	MCS 0
IEEE 802.11ac (VHT20)	9.125	9.125	9	MCS 0
IEEE 802.11ax (HE20)	9.75	9.75	9.75	MCS 0
Mode	5190 MHz	5230 MHz		Data Rate
IEEE 802.11n (HT40)	9.125	9.125		MCS 0
IEEE 802.11ac (VHT40)	9.125	9.125		MCS 0
IEEE 802.11ax (HE40)	10	10		MCS 0
Mode	5210 MHz			Data Rate
IEEE 802.11ac (VHT80)	9.125			MCS 0
IEEE 802.11ax (HE80)	9.875			MCS 0
Mode	5250 MHz			Data Rate
IEEE 802.11ac (VHT160)	8.875			MCS 0
IEEE 802.11ax (HE160)	9.375			MCS 0

UNII-2A				
Test Software	DRTU V12.1947.0-10428			
Mode	5260 MHz	5300 MHz	5320 MHz	Data Rate
IEEE 802.11a	12.25	12.375	12.5	6 Mbps
IEEE 802.11n (HT20)	9.375	9.375	9.375	MCS 0
IEEE 802.11ac (VHT20)	9	9.125	9.25	MCS 0
IEEE 802.11ax (HE20)	9.625	9.75	10	MCS 0
Mode	5270 MHz	5310 MHz		Data Rate
IEEE 802.11n (HT40)	9.125	9.125		MCS 0
IEEE 802.11ac (VHT40)	9.125	9.125		MCS 0
IEEE 802.11ax (HE40)	9.875	10.25		MCS 0
Mode	5290 MHz			Data Rate
IEEE 802.11ac (VHT80)	9			MCS 0
IEEE 802.11ax (HE80)	9.75			MCS 0

UNII-2C				
Test Software	DRTU V12.1947.0-10428			
Mode	5500 MHz	5580 MHz	5700 MHz	Data Rate
IEEE 802.11a	12.375	12.375	12.25	6 Mbps
IEEE 802.11n (HT20)	9.375	9.375	9.5	MCS 0
IEEE 802.11ac (VHT20)	9	9.125	9.25	MCS 0
IEEE 802.11ax (HE20)	9.875	10	10	MCS 0
Mode	5510 MHz	5550 MHz	5670 MHz	Data Rate
IEEE 802.11n (HT40)	9.125	9.125	9.125	MCS 0
IEEE 802.11ac (VHT40)	9.125	9.125	9.125	MCS 0
IEEE 802.11ax (HE40)	10.25	10.375	10.375	MCS 0
Mode	5530 MHz	5610 MHz		Data Rate
IEEE 802.11ac (VHT80)	9.125	9.125		MCS 0
IEEE 802.11ax (HE80)	9.75	9.875		MCS 0
Mode	5570 MHz			Data Rate
IEEE 802.11ac (VHT160)	9			MCS 0
IEEE 802.11ax (HE160)	9.625			MCS 0

UNII-3				
Test Software	DRTU V12.1947.0-10428			
Mode	5745 MHz	5785 MHz	5825 MHz	Data Rate
IEEE 802.11a	12.125	12	12.375	6 Mbps
IEEE 802.11n (HT20)	9.5	9.5	9.625	MCS 0
IEEE 802.11ac (VHT20)	9.125	9.125	9.375	MCS 0
IEEE 802.11ax (HE20)	10	10	10.25	MCS 0
Mode	5755 MHz	5795 MHz		Data Rate
IEEE 802.11n (HT40)	9.125	9.125		MCS 0
IEEE 802.11ac (VHT40)	9.125	9.125		MCS 0
IEEE 802.11ax (HE40)	10.25	10.25		MCS 0
Mode	5775 MHz			Data Rate
IEEE 802.11ac (VHT80)	9.125			MCS 0
IEEE 802.11ax (HE80)	10			MCS 0

1.5 DUTY CYCLE

If duty cycle is $\geq 98\%$, duty factor is not required.

If duty cycle is $< 98\%$, duty factor shall be considered.

Remark	Delta 1			Delta 2	On Time/Period	10 log(1/Duty Cycle)
Mode	ON (ms)	Numbers (ON)	On Time (B) (ms)	Period (ON+OFF) (ms)	Duty Cycle (%)	Duty Factor (dB)
IEEE 802.11a	2.072	1	2.072	2.136	97.00%	0.13
IEEE 802.11n (HT20)	3.976	1	3.976	4.032	98.61%	0.06
IEEE 802.11n (HT40)	3.960	1	3.960	4.060	97.54%	0.11
IEEE 802.11ac (VHT20)	4.147	1	4.147	4.213	98.43%	0.07
IEEE 802.11ac (VHT40)	1.040	1	1.040	1.090	95.41%	0.20
IEEE 802.11ac (VHT80)	0.465	1	0.465	0.550	84.55%	0.73
IEEE 802.11ac (VHT160)	0.275	1	0.275	0.320	85.94%	0.66
IEEE 802.11ax (HE20)	3.965	1	3.965	4.025	98.51%	0.07
IEEE 802.11ax (HE40)	3.940	1	3.940	4.020	98.01%	0.09
IEEE 802.11ax (HE80)	3.940	1	3.940	4.020	98.01%	0.09
IEEE 802.11ax (HE160)	3.970	1	3.970	4.050	98.02%	0.09

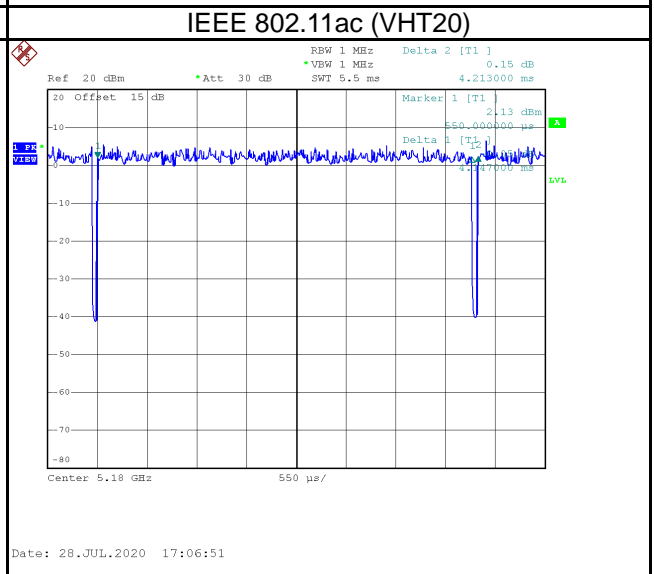
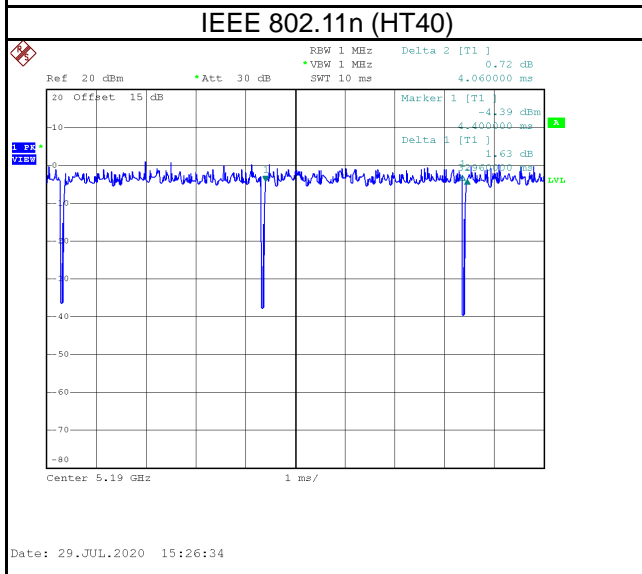
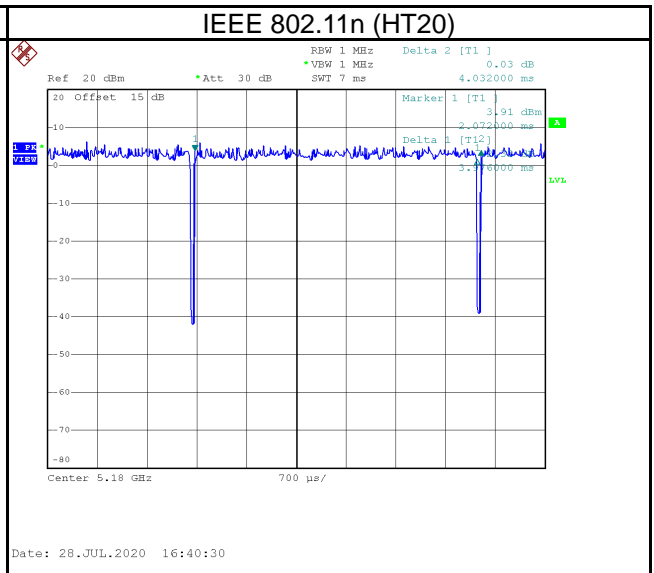
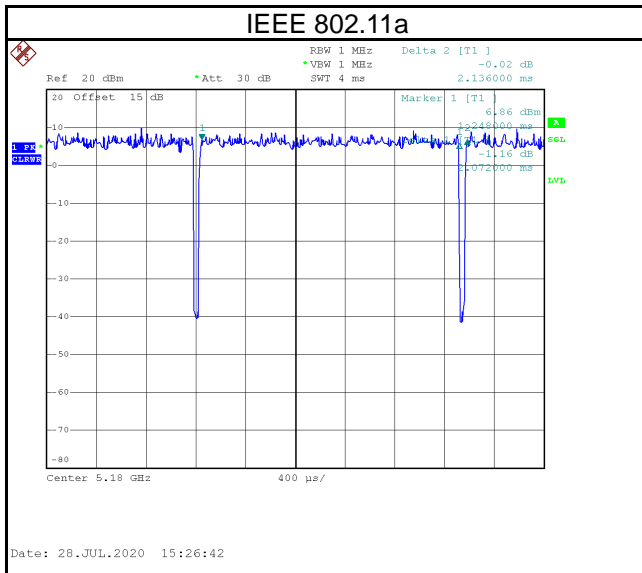

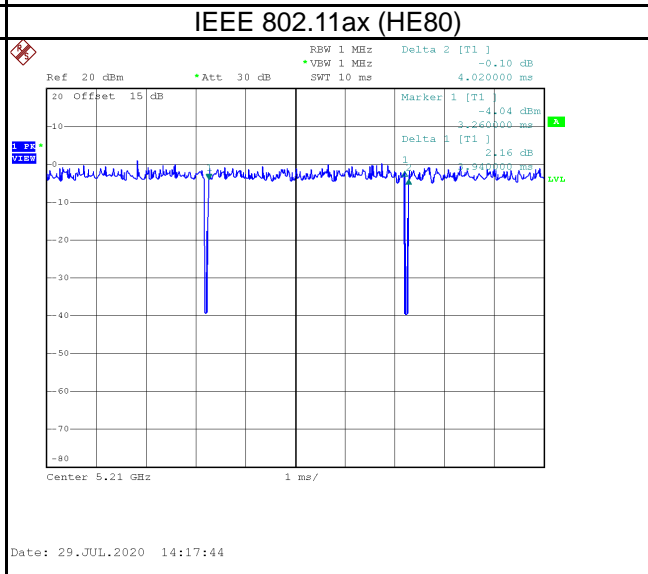
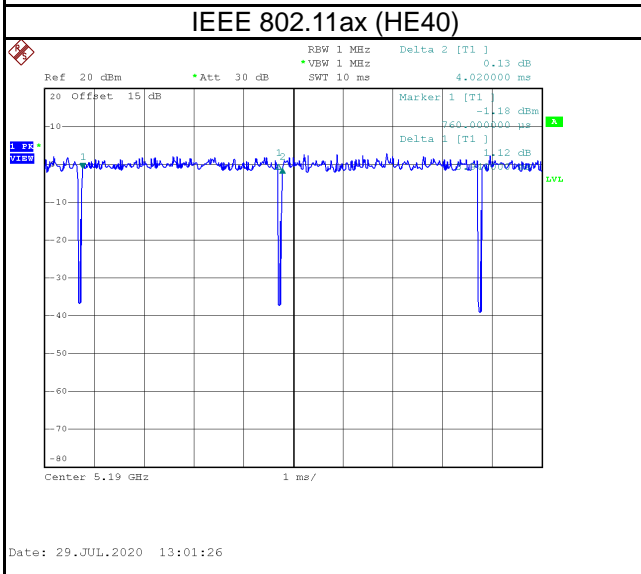
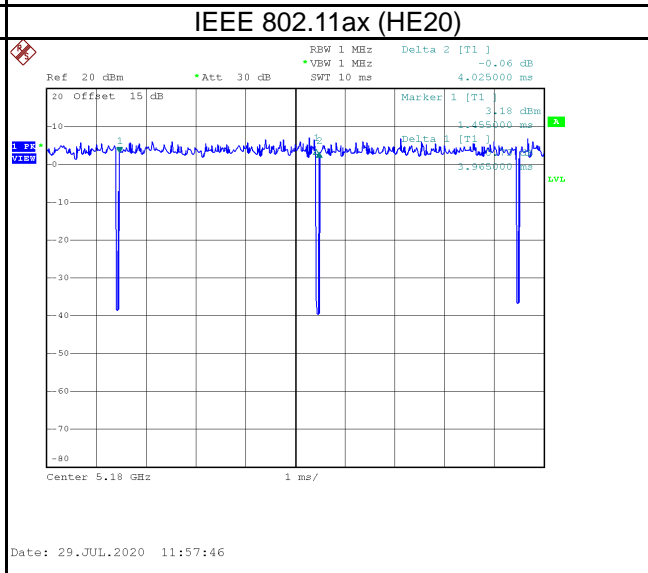
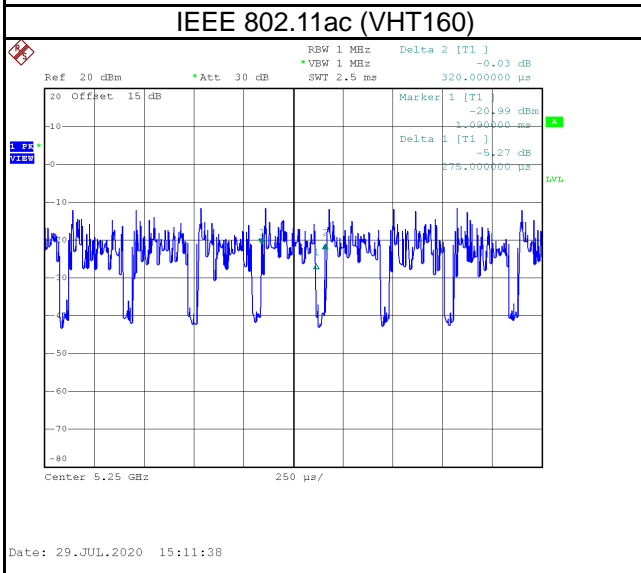
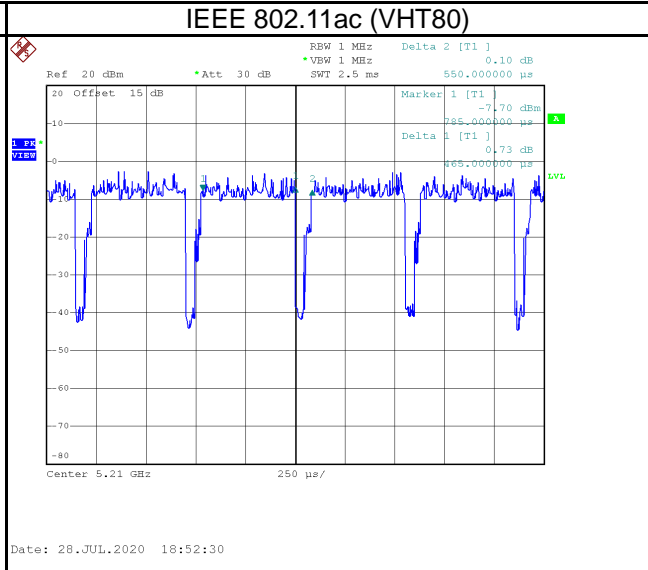
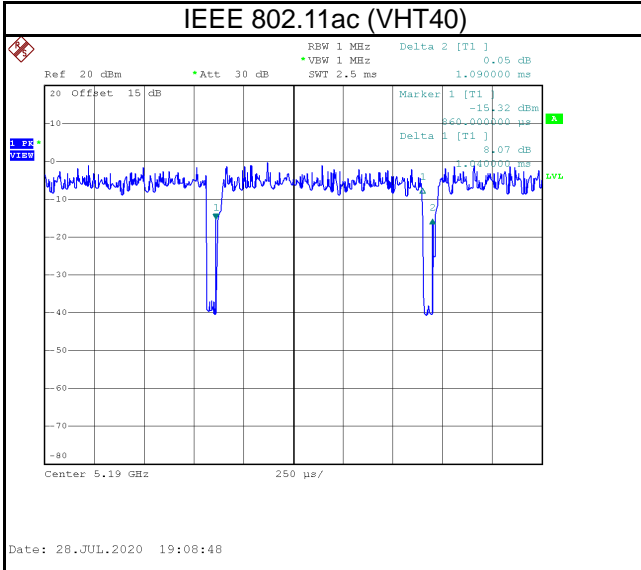

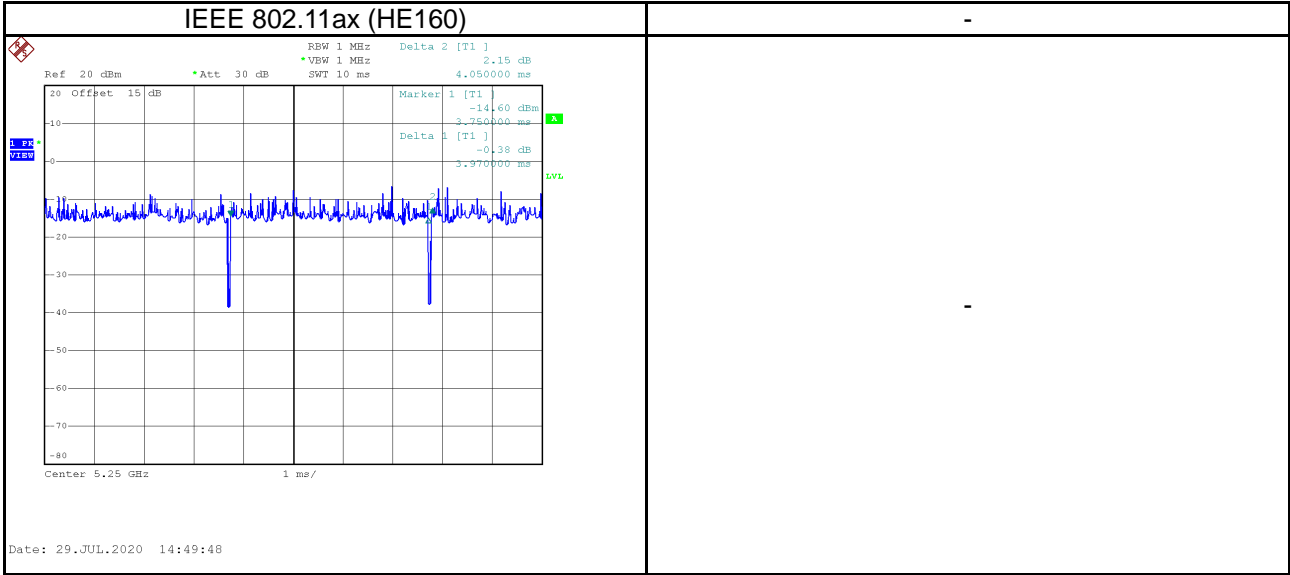

2 GENERAL INFORMATION

2.1 DESCRIPTION OF EUT

Equipment	Notebook Computer
Model Name	TP00126A, Lenovo ThinkPad C13 Yoga Gen 1 Chromebook***** (x=0~9, A~Z, "-" or blank)
Brand Name	Lenovo
Model Difference	Differ in Market proposal.
Power Source	DC voltage supplied from AC/DC Adapter.
Power Rating	20Vdc 3.25A/20Vdc 2.25A / 15Vdc 3.0A / 9Vdc 2.0A / 5Vdc 2.0A
Power Adapter Power Rating	1. I/P: 100-240V~1.3A 50-60Hz O/P: 20Vdc 2.25A / 15Vdc 3A / 9Vdc 2A / 5Vdc 2A 2. I/O: 100-240V~1.8A 50-60Hz O/P: 20Vdc 3.25A 65.0W / 15Vdc 3.0A / 9Vdc 2.0A / 5Vdc 2.0A 10.0W
Power Adapter	1. Chicony / ADLX45YCC3F 2. Liteon / ADLX65YLC3D
Frequency Range	UNII-1: 5150 MHz to 5250 MHz UNII-2A: 5250 MHz to 5350 MHz UNII-2C: 5470 MHz to 5725 MHz UNII-3: 5725 MHz to 5850 MHz
Operation Frequency	UNII-1: 5180 MHz to 5240 MHz UNII-2A: 5260 MHz to 5320 MHz UNII-2C: 5500 MHz to 5700 MHz UNII-3: 5745 MHz to 5825 MHz
Modulation Technology	OFDM
Transfer Rate	802.11a: 54/48/36/24/18/12/9/6 Mbps 802.11n: Up to 300Mbps 802.11ac: Up to 866.7 Mbps 802.11ax: Up to 2402 Mbps
Output Power Max. for UNII-1	IEEE 802.11a: 13.45 dBm (0.0221 W) IEEE 802.11n (HT20): 13.48 dBm (0.0223 W) IEEE 802.11n (HT40): 13.41 dBm (0.0219 W) IEEE 802.11ac (VHT20): 13.44 dBm (0.0221 W) IEEE 802.11ac (VHT40): 13.41 dBm (0.0219 W) IEEE 802.11ac (VHT80): 13.41 dBm (0.0219 W) IEEE 802.11ax (HE20): 13.45 dBm (0.0221 W) IEEE 802.11ax (HE40): 13.42 dBm (0.0220 W) IEEE 802.11ax (HE80): 13.45 dBm (0.0221 W) IEEE 802.11ac (VHT160): 13.42 dBm (0.0220 W) IEEE 802.11ax (HE160): 13.31 dBm (0.0214 W)
Output Power Max. for UNII-2A	IEEE 802.11a: 13.46 dBm (0.0222 W) IEEE 802.11n (HT20): 13.49 dBm (0.0223 W) IEEE 802.11n (HT40): 13.49 dBm (0.0223 W) IEEE 802.11ac (VHT20): 13.42 dBm (0.0220 W) IEEE 802.11ac (VHT40): 13.48 dBm (0.0223 W) IEEE 802.11ac (VHT80): 13.44 dBm (0.0221 W) IEEE 802.11ax (HE20): 13.45 dBm (0.0222 W) IEEE 802.11ax (HE40): 13.39 dBm (0.0218 W) IEEE 802.11ax (HE80): 13.44 dBm (0.0221 W)

Output Power Max. for UNII-2C	IEEE 802.11a: 13.48 dBm (0.0223 W) IEEE 802.11n (HT20): 13.47 dBm (0.0222 W) IEEE 802.11n (HT40): 13.36 dBm (0.0217 W) IEEE 802.11ac (VHT20): 13.36 dBm (0.0217 W) IEEE 802.11ac (VHT40): 13.49 dBm (0.0223 W) IEEE 802.11ac (VHT80): 13.43 dBm (0.0220 W) IEEE 802.11ax (HE20): 13.49 dBm (0.0223 W) IEEE 802.11ax (HE40): 13.48 dBm (0.0223 W) IEEE 802.11ax (HE80): 13.43 dBm (0.0220 W) IEEE 802.11ac (VHT160): 13.39 dBm (0.0218 W) IEEE 802.11ax (HE160): 13.43 dBm (0.0220 W)
Output Power Max. for UNII-3	IEEE 802.11a: 13.47 dBm (0.0222 W) IEEE 802.11n (HT20): 13.46 dBm (0.0222 W) IEEE 802.11n (HT40): 13.31 dBm (0.0214 W) IEEE 802.11ac (VHT20): 13.45 dBm (0.0221 W) IEEE 802.11ac (VHT40): 13.41 dBm (0.0219 W) IEEE 802.11ac (VHT80): 13.38 dBm (0.0218 W) IEEE 802.11ax (HE20): 13.47 dBm (0.0222 W) IEEE 802.11ax (HE40): 13.36 dBm (0.0217 W) IEEE 802.11ax (HE80): 13.47 dBm (0.0222 W)
Test Model	TP00126A
Sample Status	Engineering Sample
EUT Modification(s)	N/A

NOTE:

(1) For a more detailed features description, please refer to the manufacturer's specifications or the user's manual.

(2) Channel List:

IEEE 802.11a IEEE 802.11n (HT20) IEEE 802.11ac (VHT20) IEEE 802.11ax (HE20)		IEEE 802.11n (HT40) IEEE 802.11ac (VHT40) IEEE 802.11ax (HE40)		IEEE 802.11ac (VHT80) IEEE 802.11ax (HE80)	
UNII-1		UNII-1		UNII-1	
Channel	Frequency (MHz)	Channel	Frequency (MHz)	Channel	Frequency (MHz)
36	5180	38	5190	42	5210
40	5200	46	5230		
44	5220				
48	5240				

IEEE 802.11a IEEE 802.11n (HT20) IEEE 802.11ac (VHT20) IEEE 802.11ax (HE20)		IEEE 802.11n (HT40) IEEE 802.11ac (VHT40) IEEE 802.11ax (HE40)		IEEE 802.11ac (VHT80) IEEE 802.11ax (HE80)	
UNII-2A		UNII-2A		UNII-2A	
Channel	Frequency (MHz)	Channel	Frequency (MHz)	Channel	Frequency (MHz)
52	5260	54	5270	58	5290
56	5280	62	5310		
60	5300				
64	5320				

IEEE 802.11a IEEE 802.11n (HT20) IEEE 802.11ac (VHT20) IEEE 802.11ax (HE20)		IEEE 802.11n (HT40) IEEE 802.11ac (VHT40) IEEE 802.11ax (HE40)		IEEE 802.11ac (VHT80) IEEE 802.11ax (HE80)	
UNII-2C		UNII-2C		UNII-2C	
Channel	Frequency (MHz)	Channel	Frequency (MHz)	Channel	Frequency (MHz)
100	5500	102	5510	106	5530
104	5520	110	5550	122	5610
108	5540	118	5590		
112	5560	126	5630		
116	5580	134	5670		
120	5600				
124	5620				
128	5640				
132	5660				
136	5680				
140	5700				

IEEE 802.11a IEEE 802.11n (HT20) IEEE 802.11ac (VHT20) IEEE 802.11ax (HE20)		IEEE 802.11n (HT40) IEEE 802.11ac (VHT40) IEEE 802.11ax (HE40)		IEEE 802.11ac (VHT80) IEEE 802.11ax (HE80)	
UNII-3		UNII-3		UNII-3	
Channel	Frequency (MHz)	Channel	Frequency (MHz)	Channel	Frequency (MHz)
149	5745	151	5755	155	5775
153	5765	159	5795		
157	5785				
161	5805				
165	5825				

802.11ac (VHT160) 802.11ax (HE160)	
Channel	Frequency (MHz)
50	5250
114	5570

(3) Table for Filed Antenna:

Tablet Mode

Ant.	Brand	Model	Type	Frequency Range (MHz)	Gain (dBi)
Main	ICT	SA30Z18922	PIFA Antenna	2400-2500	-2.6
				5150-5350	-0.9
				5740-5725	-2.5
				5725-5875	-2.5
Aux	ICT	SA30Z18923	PIFA Antenna	2400-2500	-1.1
				5150-5350	-2.6
				5740-5725	-3.6
				5725-5875	-5.7

Ant.	Brand	Model	Type	Frequency Range (MHz)	Gain (dBi)
Main	AWAN	SA30Z18927	PIFA Antenna	2400-2500	-0.39
				5150-5350	0.21
				5740-5725	-1.28
				5725-5875	-0.64
Aux	AWAN	SA30Z18928	PIFA Antenna	2400-2500	-1.48
				5150-5350	-0.25
				5740-5725	-1.22
				5725-5875	-1.22

NB Mode

Ant.	Brand	Model	Type	Frequency Range (MHz)	Gain (dBi)
Main	ICT	SA30Z18922	PIFA Antenna	2400-2500	-2.3
				5150-5350	1.6
				5740-5725	1.9
				5725-5875	1.9
Aux	ICT	SA30Z18923	PIFA Antenna	2400-2500	-2.3
				5150-5350	1.1
				5740-5725	1.2
				5725-5875	2.0

Ant.	Brand	Model	Type	Frequency Range (MHz)	Gain (dBi)
Main	AWAN	SA30Z18927	PIFA Antenna	2400-2500	-2.11
				5150-5350	1.94
				5740-5725	1.61
				5725-5875	1.47
Aux	AWAN	SA30Z18928	PIFA Antenna	2400-2500	-1.73
				5150-5350	1.78
				5740-5725	0.71
				5725-5875	0.52

Note:

(1) The EUT incorporates a MIMO function. Physically, the EUT provides two completed transmitters and receivers (2T2R).

(2) For Power Spectral Density

5150 MHz -5250 MHz, 5250 MHz -5350 MHz:

$$\text{Directional Gain} = 10 \cdot \log\{[10^{G1/20} + 10^{G2/20} + \dots + 10^{Gn/20}]^2 / NANT\} = 4.87 \text{ dBi} < 6 \text{ dBi}$$

5740 MHz -5725 MHz:

$$\text{Directional Gain} = 10 \cdot \log\{[10^{G1/20} + 10^{G2/20} + \dots + 10^{Gn/20}]^2 / NANT\} = 4.57 \text{ dBi} < 6 \text{ dBi}$$

5725 MHz -5875 MHz:

$$\text{Directional Gain} = 10 \cdot \log\{[10^{G1/20} + 10^{G2/20} + \dots + 10^{Gn/20}]^2 / NANT\} = 4.96 \text{ dBi} < 6 \text{ dBi}$$

(3) For Conducted Output Power

$$\text{Gain} = 2 \text{ dBi} < 6 \text{ dBi}$$

(4) Operating Mode and Antenna Configuration

TX Mode \ Operating Mode	1TX	2TX
IEEE 802.11a	V (Main or Aux)	-
IEEE 802.11n (HT20)	-	V (Main+Aux)
IEEE 802.11n (HT40)	-	V (Main+Aux)
IEEE 802.11ac (VHT20)	-	V (Main+Aux)
IEEE 802.11ac (VHT40)	-	V (Main+Aux)
IEEE 802.11ac (VHT80)	-	V (Main+Aux)
IEEE 802.11ac (VHT160)	-	V (Main+Aux)
IEEE 802.11ax (HE20)	-	V (Main+Aux)
IEEE 802.11ax (HE40)	-	V (Main+Aux)
IEEE 802.11ax (HE80)	-	V (Main+Aux)
IEEE 802.11ax (HE160)	-	V (Main+Aux)

2.2 TEST MODES

Test Items	Test mode	Channel	Note
AC power line conducted emissions	Normal/Idle	-	-
Transmitter Radiated Emissions (below 1GHz)	TX Mode_IEEE 802.11ax (HE80)	155	-
Transmitter Radiated Emissions (above 1GHz)	TX Mode_IEEE 802.11a	36/48, 52/64	Bandedge
	TX Mode_IEEE 802.11ac (VHT20)	100/140, 149/165	
	TX Mode_IEEE 802.11ax (HE20)		
	TX Mode_IEEE 802.11ac (VHT40)	38/46, 54/62	
	TX Mode_IEEE 802.11ax (HE40)	102/134, 151/159	
	TX Mode_IEEE 802.11ac (VHT80)	42, 58	Harmonic
	TX Mode_IEEE 802.11ax (HE80)	106/122, 155	
	TX Mode_IEEE 802.11ac (VHT160)	50	
	TX Mode_IEEE 802.11ax (HE160)	114	
	TX Mode_IEEE 802.11a	36/40/48	
TX Mode_IEEE 802.11ac (VHT20)	52/60/64	Harmonic	
TX Mode_IEEE 802.11ax (HE20)	100/116/140		
TX Mode_IEEE 802.11ax (HE20)	149/157/165		
TX Mode_IEEE 802.11ac (VHT40)	38/46/ 54/62		
TX Mode_IEEE 802.11ax (HE40)	102/110/134 151/159		
TX Mode_IEEE 802.11ac (VHT80)	42, 58	-	
TX Mode_IEEE 802.11ax (HE80)	106/122, 155		
TX Mode_IEEE 802.11ac (VHT160)	50		
TX Mode_IEEE 802.11ax (HE160)	114		
TX Mode_IEEE 802.11a	36/40/48		-
TX Mode_IEEE 802.11ac (VHT20)	52/60/64		
TX Mode_IEEE 802.11ax (HE20)	100/116/140		
TX Mode_IEEE 802.11ax (HE20)	149/157/165		
TX Mode_IEEE 802.11ac (VHT40)	38/46/ 54/62		
TX Mode_IEEE 802.11ax (HE40)	102/110/134 151/159	-	
TX Mode_IEEE 802.11ac (VHT80)	42, 58		
TX Mode_IEEE 802.11ax (HE80)	106/122, 155		
TX Mode_IEEE 802.11ac (VHT160)	50		
TX Mode_IEEE 802.11ax (HE160)	114		
Output Power	TX Mode_IEEE 802.11a	36/40/48	-
	TX Mode_IEEE 802.11n (HT20)	52/60/64	
	TX Mode_IEEE 802.11ac (VHT20)	100/116/140	
	TX Mode_IEEE 802.11ax (HE20)	149/157/165	
	TX Mode_IEEE 802.11n (HT40)	38/46/ 54/62	
	TX Mode_IEEE 802.11ac (VHT40)	102/110/134 151/159	
TX Mode_IEEE 802.11ax (HE40)			
TX Mode_IEEE 802.11ac (VHT80)	42, 58	-	
TX Mode_IEEE 802.11ax (HE80)	106/122, 155		
TX Mode_IEEE 802.11ac (VHT160)	50	-	
TX Mode_IEEE 802.11ax (HE160)	114		

NOTE:

- (1) The Radiated emissions test was verified based on the worst conducted power and Bandwidth test results reported in the original report.
- (2) For radiated emission band edge test, both Vertical and Horizontal are evaluated, but only the worst case (Vertical) is recorded.
- (3) All X, Y and Z axes are evaluated, but only the worst case (Y axis) is recorded.
- (4) There were no emissions found below 30 MHz within 20 dB of the limit.
- (5) All adapter are evaluated, the ADLX65YLC3D is the worst and recorded as below test data.
- (6) The RU value of output power testing on AX modes is Fully RU.

2.3 BLOCK DIAGRAM SHOWING THE CONFIGURATION OF SYSTEM TESTED

Equipment letters and Cable numbers refer to item numbers described in the tables of clause 2.4.

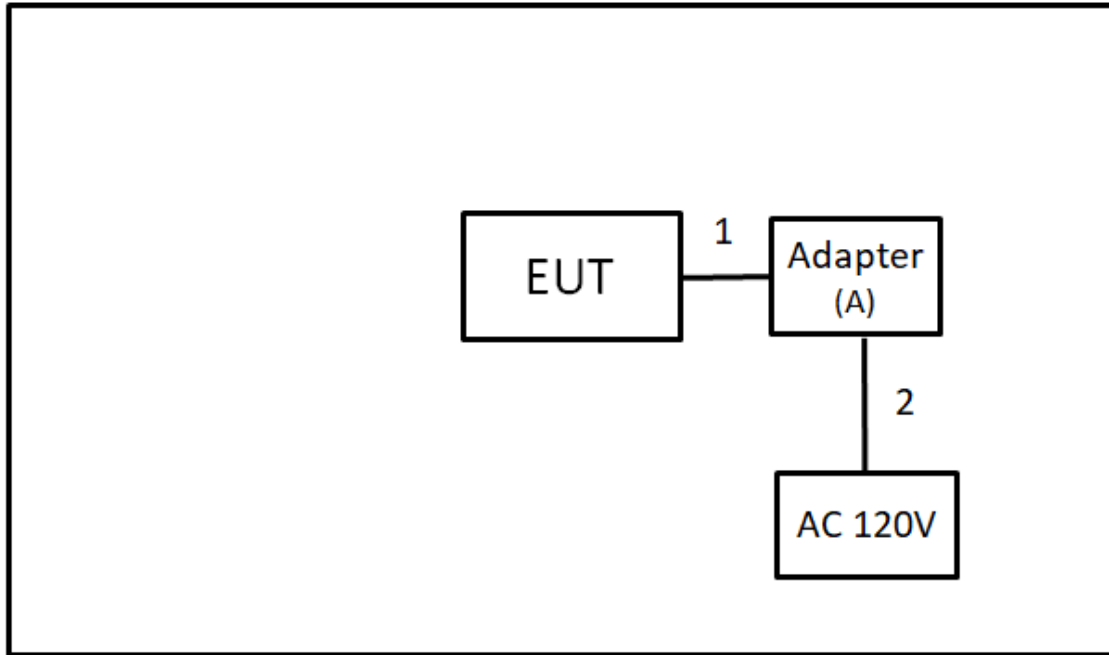

2.4 SUPPORT UNITS

Item	Equipment	Brand	Model No.	Series No.	Remarks
A	Adapter	Lenove	ADLX65YLC3D	N/A	Supplied by test requester

Item	Shielded	Ferrite Core	Length	Cable Type	Remarks
1	N/A	N/A	1.6m	Adapter Cable	Supplied by test requester
2	N/A	N/A	0.9m	power core	Supplied by test requester

3 AC POWER LINE CONDUCTED EMISSIONS TEST

3.1 LIMIT

Frequency (MHz)	Limit (dB μ V)	
	Quasi-peak	Average
0.15 - 0.5	66 - 56 *	56 - 46 *
0.50 - 5.0	56	46
5.0 - 30.0	60	50

NOTE:

- (1) The tighter limit applies at the band edges.
- (2) The limit of " * " marked band means the limitation decreases linearly with the logarithm of the frequency in the range.
- (3) The test result calculated as following:
 Measurement Value = Reading Level + Correct Factor
 Correct Factor = Insertion Loss + Cable Loss + Attenuator Factor (if use)
 Margin Level = Measurement Value – Limit Value
 Calculation example:

Reading Level		Correct Factor		Measurement Value
38.22	+	3.45	=	41.67

Measurement Value		Limit Value		Margin Level
41.67	-	60	=	-18.33

The following table is the setting of the receiver.

Receiver Parameter	Setting
Attenuation	10 dB
Start Frequency	0.15 MHz
Stop Frequency	30 MHz
IF Bandwidth	9 KHz

3.2 TEST PROCEDURE

- a. The EUT was placed 0.8 m above the horizontal ground plane with the EUT being connected to the power mains through a line impedance stabilization network (LISN).
 All other support equipment were powered from an additional LISN(s).
 The LISN provides 50 Ohm/50uH of impedance for the measuring instrument.
- b. Interconnecting cables that hang closer than 40 cm to the ground plane shall be folded back and forth in the center forming a bundle to keep the cable above 40 cm.
- c. Excess I/O cables that are not connected to a peripheral shall be bundled in the center.
 The end of the cable will be terminated, using the correct terminating impedance.
 The overall length shall not exceed 1 m.
- d. The LISN is spaced at least 80 cm from the nearest part of the EUT chassis.
- e. For the actual test configuration, please refer to the related Item – EUT TEST PHOTO.

NOTE:

- (1) In the results, each reading is marked as Peak, QP or AVG per the detector used.
 BW=9 kHz (6 dB Bandwidth)
- (2) All readings are Peak unless otherwise stated QP or AVG in column of Note. Both the QP and the AVG readings must be less than the limit for compliance.

3.3 DEVIATION FROM TEST STANDARD

No deviation.

3.4 TEST SETUP

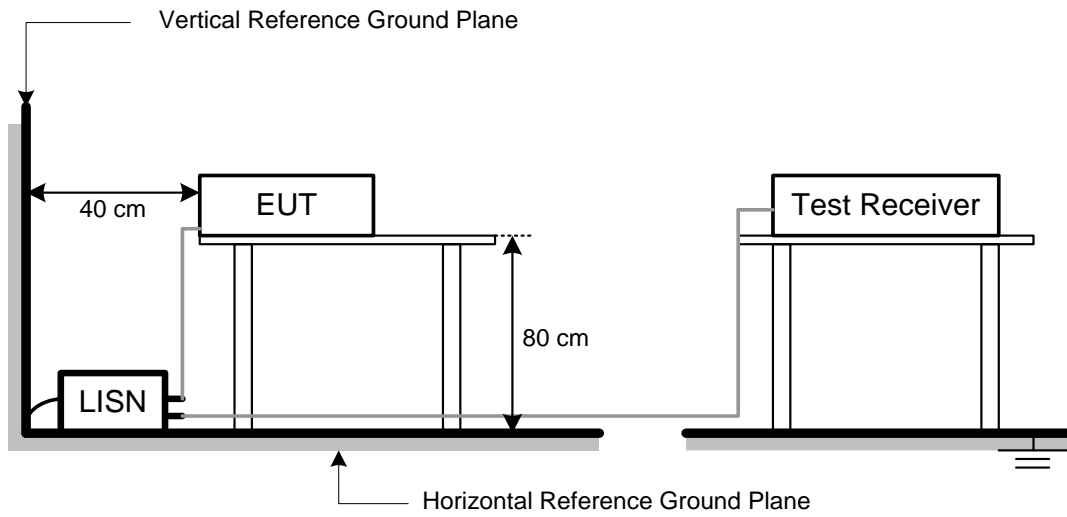

3.5 TEST RESULT

Please refer to the APPENDIX A.

4 RADIATED EMISSIONS TEST

4.1 LIMIT

In case the emission fall within the restricted band specified on 15.205, then the 15.209 limit in the table below has to be followed.

LIMITS OF RADIATED EMISSIONS MEASUREMENT (9 kHz to 1000 MHz)

Frequency (MHz)	Field Strength (microvolts/meter)	Measurement Distance (meters)
0.009~0.490	2400/F(KHz)	300
0.490~1.705	24000/F(KHz)	30
1.705~30.0	30	30
30~88	100	3
88~216	150	3
216~960	200	3
960~1000	500	3

LIMITS OF UNWANTED EMISSION OUT OF THE RESTRICTED BANDS

Frequency (MHz)	EIRP Limit (dBm)	Equivalent Field Strength at 3m (dBμV/m)
5150-5250	-27	68.3
5250-5350	-27	68.3
5470-5725	-27	68.3
5725-5850	-27 (NOTE 2)	68.3
	10 (NOTE 2)	105.3
	15.6 (NOTE 2)	110.9
	27 (NOTE 2)	122.3

NOTE:

(1) The following formula is used to convert the equipment isotropic radiated power (eirp) to field strength:

$$E = \frac{1000000\sqrt{30P}}{3} \mu\text{V/m, where P is the eirp (Watts)}$$

(2) According to FCC 16-24, All emissions shall be limited to a level of -27 dBm/MHz at 75 MHz or more above or below the band edge increasing linearly to 10 dBm/MHz at 25 MHz above or below the band edge, and from 25 MHz above or below the band edge increasing linearly to a level of 15.6 dBm/MHz at 5 MHz above or below the band edge, and from 5 MHz above or below the band edge increasing linearly to a level of 27 dBm/MHz at the band edge.

(3) The test result calculated as following:

Measurement Value = Reading Level + Correct Factor

Correct Factor = Antenna Factor + Cable Loss - Amplifier Gain(if use)

Margin Level = Measurement Value - Limit Value

Calculation example:

Reading Level		Correct Factor		Measurement Value
36.23	+	-11.97	=	24.26

Measurement Value		Limit Value		Margin Level
24.26	-	40	=	-15.74

Spectrum Parameter	Setting
Attenuation	Auto
Start Frequency	1000 MHz
Stop Frequency	10th carrier harmonic
RBW / VBW (Emission in restricted band)	1MHz / 3MHz for Peak, 1MHz / 1/T for Average

Spectrum Parameter	Setting
Attenuation	Auto
Start ~ Stop Frequency	9KHz~90KHz for PK/AVG detector
Start ~ Stop Frequency	90KHz~110KHz for QP detector
Start ~ Stop Frequency	110KHz~490KHz for PK/AVG detector
Start ~ Stop Frequency	490KHz~30MHz for QP detector
Start ~ Stop Frequency	30MHz~1000MHz for QP detector

4.2 TEST PROCEDURE

- a. The measuring distance of 3 m shall be used for measurements. The EUT was placed on the top of a rotating table 0.8 meter above the ground at a 3 meter semi-anechoic chamber. The table was rotated 360 degrees to determine the position of the highest radiation.(below 1GHz)
- b. The measuring distance of 3 m shall be used for measurements. The EUT was placed on the top of a rotating table 1.5 meter above the ground at a 3 meter semi-anechoic chamber. The table was rotated 360 degrees to determine the position of the highest radiation.(above 1GHz)
- c. The height of the equipment or of the substitution antenna shall be 0.8 m or 1.5 m, the height of the test antenna shall vary between 1 m to 4 m. Both horizontal and vertical polarizations of the antenna are set to make the measurement.
- d. For each suspected emission, the EUT was arranged to its worst case and then the antenna was tuned to heights find the maximum reading (used Bore sight function).
- e. The receiver system was set to peak and average detect function and specified bandwidth with maximum hold mode when the test frequency is above 1GHz.
- f. The initial step in collecting radiated emission data is a receiver peak detector mode pre-scanning the measurement frequency range. Significant peaks are then marked and then Quasi Peak detector mode re-measured.
- g. All readings are Peak unless otherwise stated QP in column of Note. Peak denotes that the Peak reading compliance with the QP Limits and then QP Mode measurement didn't perform. (below 1GHz)
- h. All readings are Peak Mode value unless otherwise stated AVG in column of Note. If the Peak Mode Measured value compliance with the Peak Limits and lower than AVG Limits, the EUT shall be deemed to meet both Peak & AVG Limits and then only Peak Mode was measured, but AVG Mode didn't perform. (above 1GHz)
- i. For the actual test configuration, please refer to the related Item – EUT TEST PHOTO.

4.3 DEVIATION FROM TEST STANDARD

No deviation.

4.4 TEST SETUP

30 MHz to 1 GHz

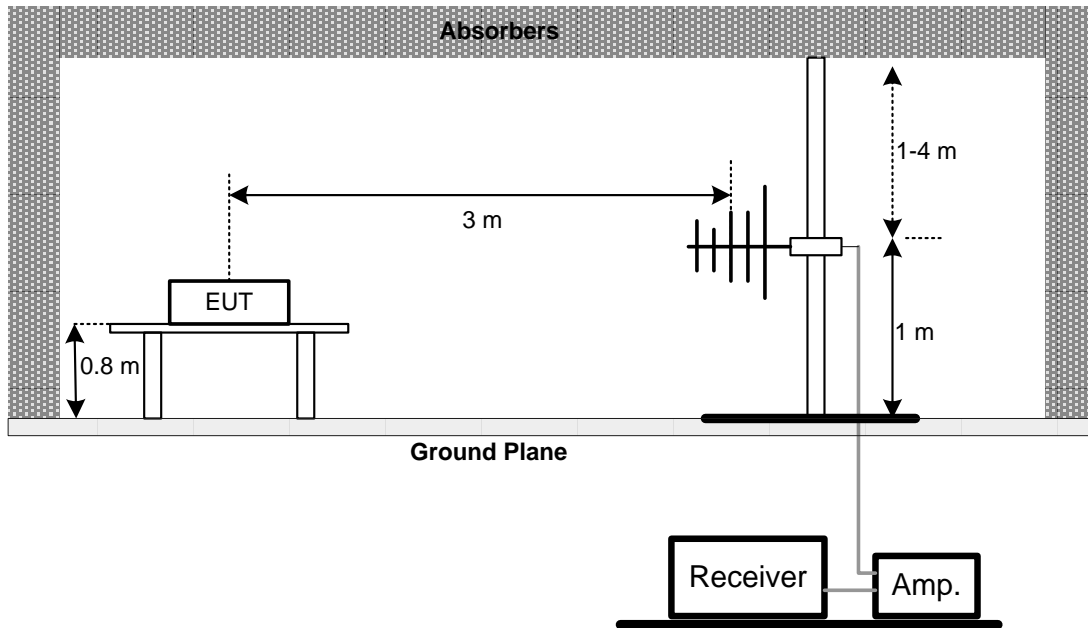

Above 1 GHz

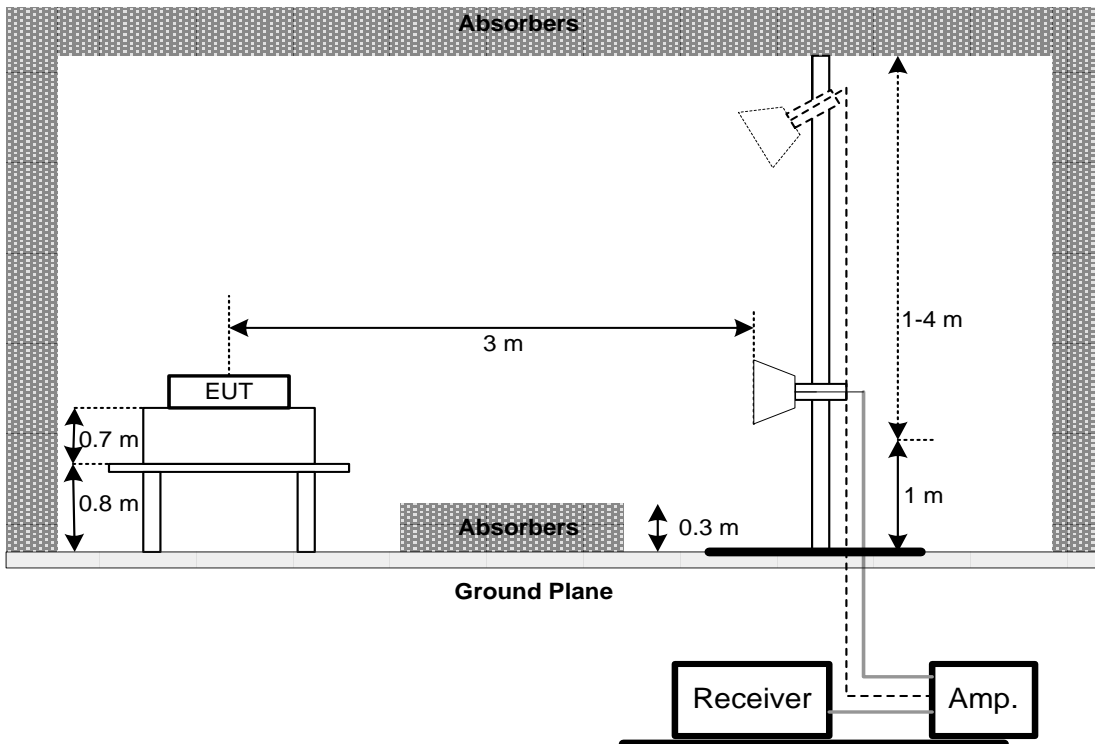

4.5 EUT OPERATING CONDITIONS

The EUT was programmed to be in continuously transmitting mode.

4.6 TEST RESULT – 30 MHZ TO 1 GHZ

Please refer to the APPENDIX B.

4.7 TEST RESULT – ABOVE 1 GHZ

Please refer to the APPENDIX C.

NOTE:

- (1) No limit: This is fundamental signal, the judgment is not applicable.
For fundamental signal judgment was referred to Peak output test.

5 BANDWIDTH TEST

5.1 LIMIT

FCC Part15, Subpart E (15.407)		
Section	Test Item	Frequency Range (MHz)
15.407(a)	26 dB Bandwidth	5150-5250
		5250-5350
		5470-5725
	Minimum 500 kHz 6 dB Bandwidth	5725-5850

5.2 TEST PROCEDURE

- a. The EUT was directly connected to the spectrum analyzer and antenna output port as show in the block diagram below.
- b. Spectrum Setting:

Spectrum Parameter	Setting
Attenuation	Auto
Span Frequency	> 26 dB Bandwidth
RBW	300 kHz(Bandwidth 20 MHz) 1 MHz(Bandwidth 40 MHz and 80 MHz)
VBW	1 MHz(Bandwidth 20 MHz) 3 MHz(Bandwidth 40 MHz and 80 MHz)
Detector	Peak
Trace	Max Hold
Sweep Time	Auto

5.3 DEVIATION FROM TEST STANDARD

No deviation.

5.4 TEST SETUP

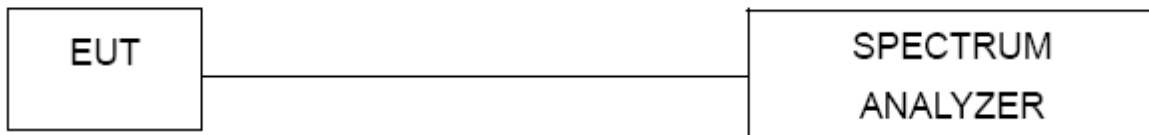

5.5 EUT OPERATING CONDITIONS

The EUT was programmed to be in continuously transmitting mode.

5.6 TEST RESULT

Please refer to the APPENDIX D.

6 OUTPUT POWER TEST

6.1 LIMIT

FCC Part15, Subpart E (15.407)			
Section	Test Item	Limit	Frequency Range (MHz)
15.407(a)	Maximum Output Power	Fixed:1 Watt (30 dBm) Mobile and portable: 250 mW (24 dBm)	5150-5250
		250 mW (24 dBm)	5250-5350
			5470-5725
		1 Watt (30dBm)	5725-5850

Note: The maximum e.i.r.p at any elevation angle above 30 degrees as measured from the horizon must not exceed 125 mW(21 dBm).

6.2 TEST PROCEDURE

- a. The EUT was directly connected to the power meter and antenna output port as show in the block diagram below.
- b. Spectrum Setting:

Spectrum Parameter	Setting
Attenuation	Auto
Span Frequency	Encompass the entire emissions bandwidth (EBW) of the signal
RBW	= 1 MHz
VBW	≥ 3 MHz
Detector	RMS
Trace	Max Hold
Sweep Time	auto

- c. The maximum peak conducted output power was performed in accordance with method of FCC KDB 789033 D02 General UNII Test Procedures New Rules v02r01.

6.3 DEVIATION FROM TEST STANDARD

No deviation.

6.4 TEST SETUP



6.5 EUT OPERATING CONDITIONS

The EUT was programmed to be in continuously transmitting mode.

6.6 TEST RESULT

Please refer to the APPENDIX E.

7 POWER SPECTRAL DENSITY

7.1 LIMIT

FCC Part15, Subpart E (15.407)			
Section	Test Item	Limit	Frequency Range (MHz)
15.407(a)	Power Spectral Density	Other than Mobile and portable: 17 dBm/MHz	5150-5250
		Mobile and portable: 11 dBm/MHz	
		11 dBm/MHz	5250-5350
		30 dBm/500 kHz	5470-5725
			5725-5850

7.2 TEST PROCEDURE

- a. The EUT was directly connected to the spectrum analyzer and antenna output port as show in the block diagram below.
- b. Spectrum Setting:

Spectrum Parameter	Setting
Attenuation	Auto
Span Frequency	Encompass the entire emissions bandwidth (EBW) of the signal
RBW	= 1 MHz
VBW	≥ 3 MHz
Detector	RMS
Trace	Max Hold
Sweep Time	Auto

7.3 DEVIATION FROM TEST STANDARD

No deviation.

7.4 TEST SETUP

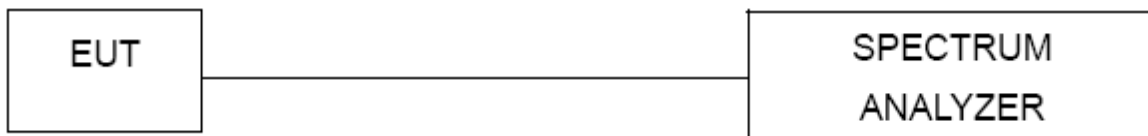

7.5 EUT OPERATING CONDITIONS

The EUT was programmed to be in continuously transmitting mode.

7.6 TEST RESULT

Please refer to the APPENDIX F.

8 LIST OF MEASURING EQUIPMENTS

AC Power Line Conducted Emissions						
Item	Kind of Equipment	Manufacturer	Type No.	Serial No.	Calibrated Date	Calibrated Until
1	TWO-LINE V-NETWORK	R&S	ENV216	101050	2020/6/11	2021/6/11
2	Test Cable	EMCI	EMC400-BM-BM-5000	170501	2019/8/15	2020/8/14
3	EMI Test Receiver	R&S	ESR7	101433	2019/12/13	2020/12/11
4	Measurement Software	EZ	EZ EMC (Version NB-03A1-01)	N/A	N/A	N/A

Radiated Emissions						
Item	Kind of Equipment	Manufacturer	Type No.	Serial No.	Calibrated Date	Calibrated Until
1	Preamplifier	EMCI	EMC001340	980555	2020/4/10	2021/4/9
2	Preamplifier	EMCI	EMC02325B	980217	2020/4/10	2021/4/9
3	Preamplifier	EMCI	EMC012645B	980267	2020/4/10	2021/4/9
4	Preamplifier	EMCI	EMC2654045	980030	2020/1/31	2021/1/30
5	Test Cable	EMCI	EMC104-SM-SM-800	150207	2020/4/10	2021/4/9
6	Test Cable	EMCI	EMC104-SM-SM-3000	151205	2020/4/10	2021/4/9
7	Test Cable	EMCI	EMC-SM-SM-7000	180408	2020/4/10	2021/4/9
8	MXE EMI Receiver	Agilent	N9038A	MY554200087	2020/6/10	2021/6/9
9	Signal Analyzer	Agilent	N9010A	MY56480554	2020/6/4	2021/6/3
10	Loop Ant	EMCO	6502	274	2020/6/16	2021/6/15
11	Horn Ant	SCHWARZBECK	BBHA 9120D	9120D-1342	2020/6/12	2021/6/11
12	Horn Ant	Schwarzbeck	BBHA 9170	187	2019/12/21	2020/12/20
13	Trilog-Broadband Antenna	Schwarzbeck	VULB 9168	0992	2020/7/10	2021/7/9
14	5dB Attenuator	EMCI	EMCI-N-6-05	AT-N0508	2020/7/10	2021/7/9

Bandwidth						
Item	Kind of Equipment	Manufacturer	Type No.	Serial No.	Calibrated Date	Calibrated Until
1	Spectrum Analyzer	R&S	FSP 40	100129	2020/6/15	2021/6/14

Output Power						
Item	Kind of Equipment	Manufacturer	Type No.	Serial No.	Calibrated Date	Calibrated Until
1	Power Meter	Keysight	8990B	MY51000517	2020/4/6	2021/4/5
2	Power Sensor	Keysight	N1923A	MY58310005	2020/4/6	2021/4/5

Power Spectral Density						
Item	Kind of Equipment	Manufacturer	Type No.	Serial No.	Calibrated Date	Calibrated Until
1	Spectrum Analyzer	R&S	FSP 40	100129	2020/6/15	2021/6/14

Remark: "N/A" denotes no model name, no serial no. or no calibration specified.
All calibration period of equipment list is one year.

9 EUT TEST PHOTO

Please refer to document Appendix No.: TP-2006T132-FCCP-1 (APPENDIX-TEST PHOTOS).

10 EUT PHOTOS

Please refer to document Appendix No.: EP-2006T132-1 (APPENDIX-EUT PHOTOS).

APPENDIX A AC POWER LINE CONDUCTED EMISSIONS

Test Mode	Normal	Tested Date	2020/7/30
Test Frequency	-	Phase	Line

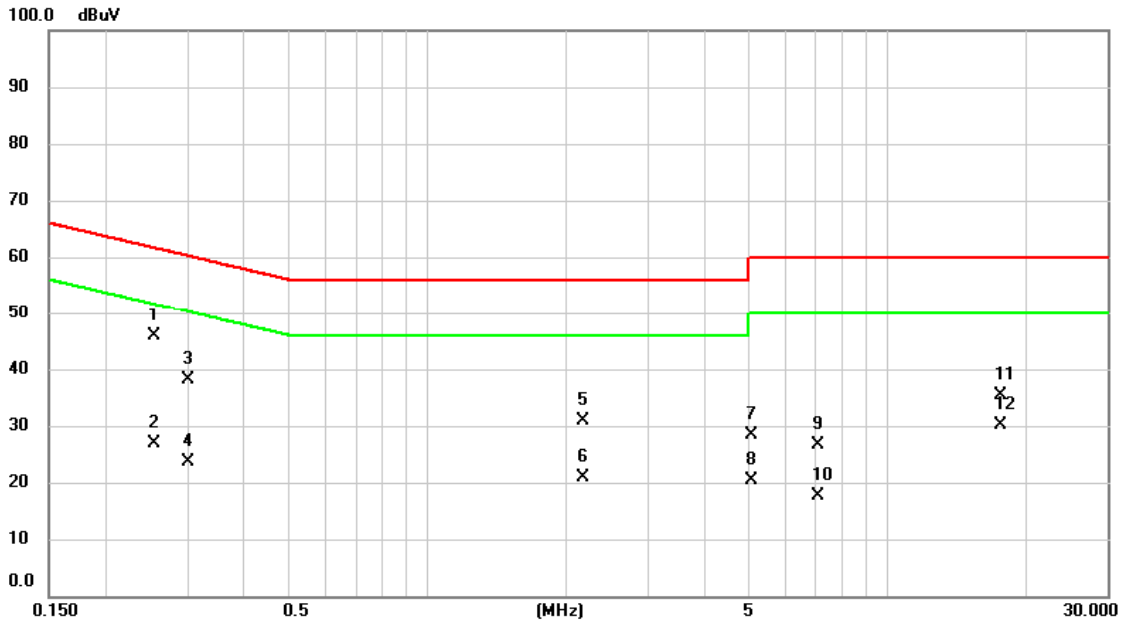

No.	Mk.	Freq. MHz	Reading Level dBuV	Correct Factor dB	Measure- ment dBuV	Limit dBuV	Over dB	Detector	Comment
1	*	0.2535	36.25	9.68	45.93	61.64	-15.71	QP	
2		0.2535	17.30	9.68	26.98	51.64	-24.66	AVG	
3		0.3007	28.52	9.68	38.20	60.22	-22.02	QP	
4		0.3007	14.05	9.68	23.73	50.22	-26.49	AVG	
5		2.1795	21.14	9.74	30.88	56.00	-25.12	QP	
6		2.1795	11.13	9.74	20.87	46.00	-25.13	AVG	
7		5.0843	18.48	9.83	28.31	60.00	-31.69	QP	
8		5.0843	10.43	9.83	20.26	50.00	-29.74	AVG	
9		7.0665	16.76	9.87	26.63	60.00	-33.37	QP	
10		7.0665	7.72	9.87	17.59	50.00	-32.41	AVG	
11		17.5785	25.48	9.96	35.44	60.00	-24.56	QP	
12		17.5785	20.23	9.96	30.19	50.00	-19.81	AVG	

REMARKS:

- (1) Measurement Value = Reading Level + Correct Factor.
- (2) Margin Level = Measurement Value - Limit Value.

Test Mode	Normal	Tested Date	2020/7/30
Test Frequency	-	Phase	Neutral

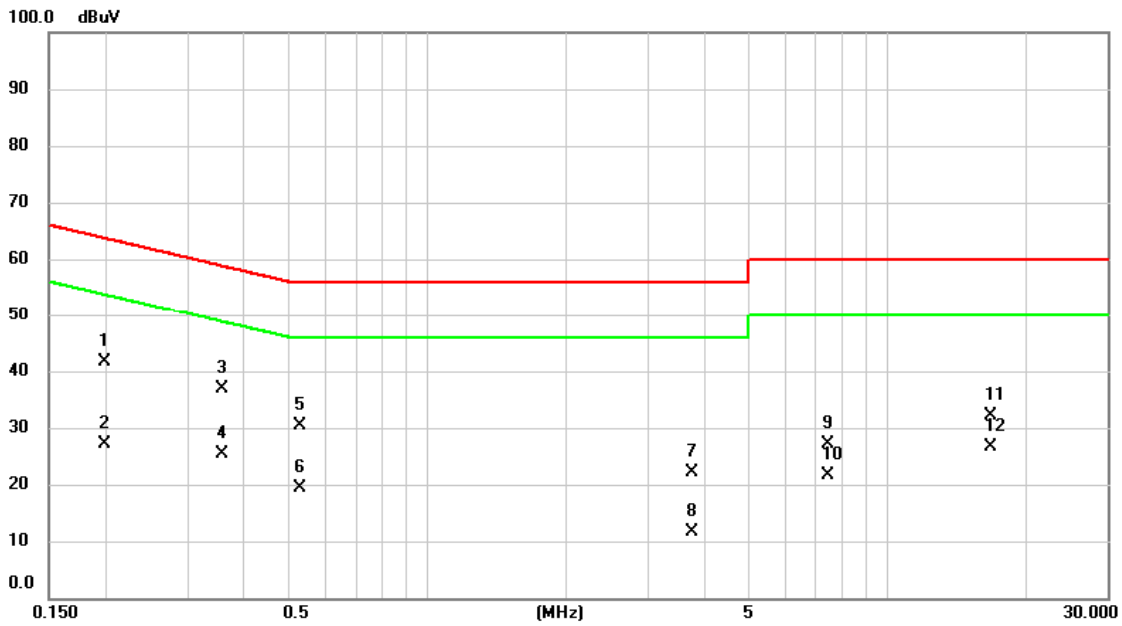

No.	Mk.	Freq. MHz	Reading Level dBuV	Correct Factor dB	Measure- ment dBuV	Limit dBuV	Over dB	Detector	Comment
1		0.1976	32.00	9.67	41.67	63.71	-22.04	QP	
2		0.1976	17.49	9.67	27.16	53.71	-26.55	AVG	
3	*	0.3592	27.11	9.68	36.79	58.75	-21.96	QP	
4		0.3592	15.80	9.68	25.48	48.75	-23.27	AVG	
5		0.5302	20.70	9.68	30.38	56.00	-25.62	QP	
6		0.5302	9.77	9.68	19.45	46.00	-26.55	AVG	
7		3.7343	12.31	9.79	22.10	56.00	-33.90	QP	
8		3.7343	1.95	9.79	11.74	46.00	-34.26	AVG	
9		7.4535	17.28	9.87	27.15	60.00	-32.85	QP	
10		7.4535	11.72	9.87	21.59	50.00	-28.41	AVG	
11		16.7663	22.06	9.95	32.01	60.00	-27.99	QP	
12		16.7663	16.80	9.95	26.75	50.00	-23.25	AVG	

REMARKS:

- (1) Measurement Value = Reading Level + Correct Factor.
- (2) Margin Level = Measurement Value - Limit Value.

Test Mode	Idle	Tested Date	2020/7/30
Test Frequency	-	Phase	Line

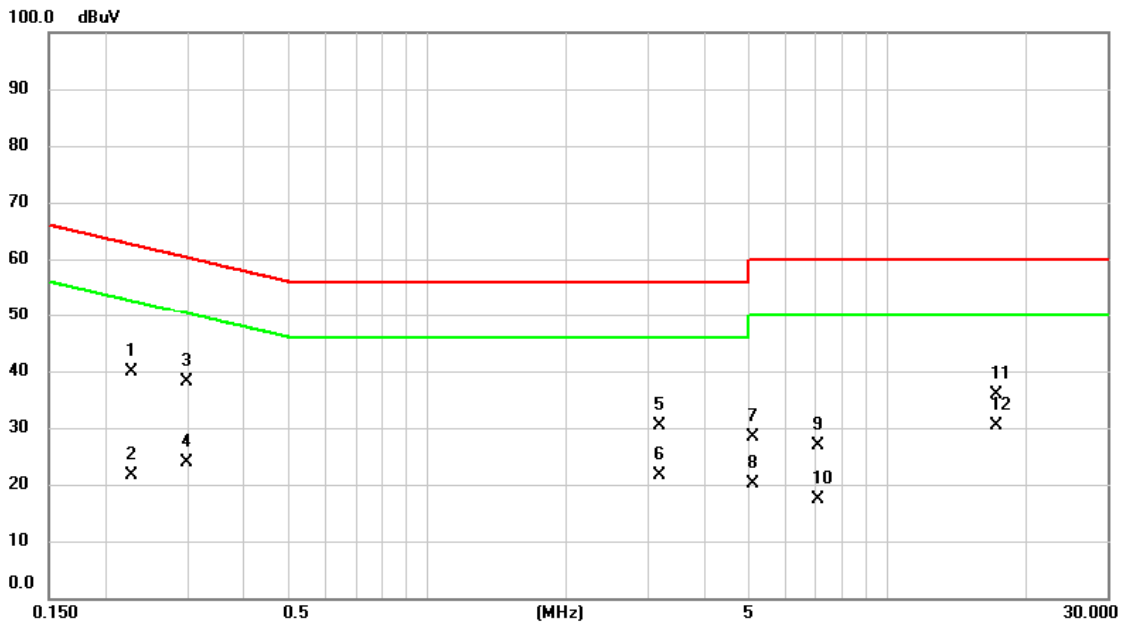

No.	Mk.	Freq. MHz	Reading Level dBuV	Correct Factor dB	Measure- ment dBuV	Limit dBuV	Over dB	Detector	Comment
1		0.2265	30.23	9.68	39.91	62.58	-22.67	QP	
2		0.2265	11.90	9.68	21.58	52.58	-31.00	AVG	
3		0.2985	28.51	9.69	38.20	60.28	-22.08	QP	
4		0.2985	14.08	9.69	23.77	50.28	-26.51	AVG	
5		3.1762	20.53	9.76	30.29	56.00	-25.71	QP	
6		3.1762	11.96	9.76	21.72	46.00	-24.28	AVG	
7		5.1180	18.44	9.83	28.27	60.00	-31.73	QP	
8		5.1180	10.26	9.83	20.09	50.00	-29.91	AVG	
9		7.0665	17.10	9.87	26.97	60.00	-33.03	QP	
10		7.0665	7.57	9.87	17.44	50.00	-32.56	AVG	
11		17.1983	25.84	9.95	35.79	60.00	-24.21	QP	
12	*	17.1983	20.41	9.95	30.36	50.00	-19.64	AVG	

REMARKS:

- (1) Measurement Value = Reading Level + Correct Factor.
- (2) Margin Level = Measurement Value - Limit Value.

Test Mode	Idle	Tested Date	2020/7/30
Test Frequency	-	Phase	Neutral

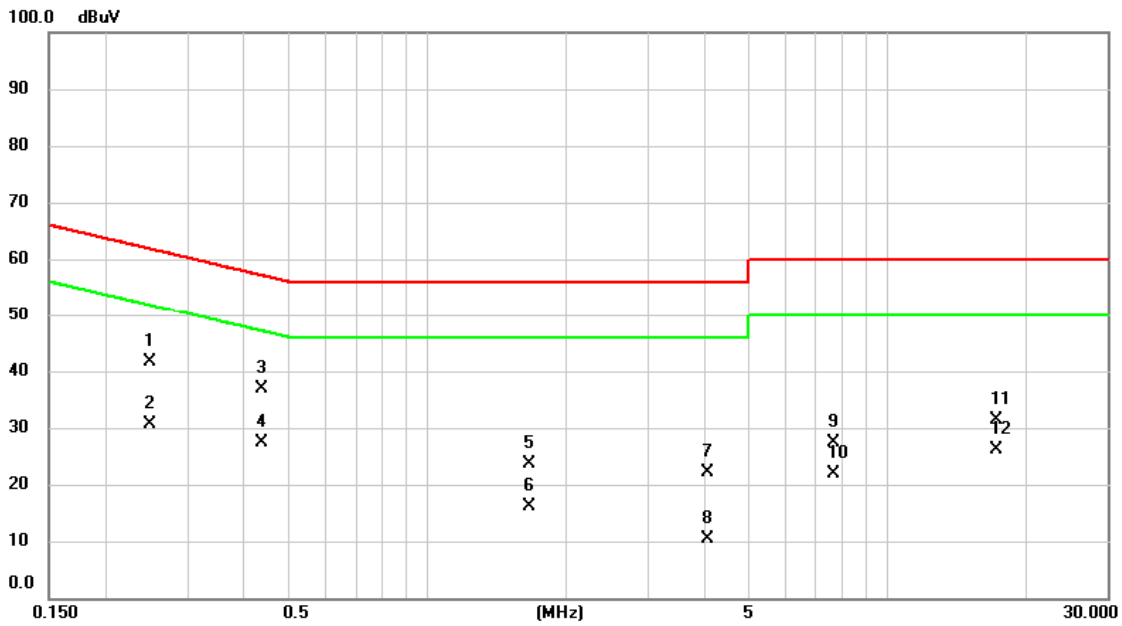

No.	Mk.	Freq. MHz	Reading Level dBuV	Correct Factor dB	Measure- ment dBuV	Limit dBuV	Over dB	Detector	Comment
1		0.2490	32.07	9.68	41.75	61.79	-20.04	QP	
2		0.2490	20.91	9.68	30.59	51.79	-21.20	AVG	
3		0.4380	27.29	9.68	36.97	57.10	-20.13	QP	
4	*	0.4380	17.65	9.68	27.33	47.10	-19.77	AVG	
5		1.6620	13.83	9.73	23.56	56.00	-32.44	QP	
6		1.6620	6.28	9.73	16.01	46.00	-29.99	AVG	
7		4.0538	12.24	9.80	22.04	56.00	-33.96	QP	
8		4.0538	0.58	9.80	10.38	46.00	-35.62	AVG	
9		7.6403	17.51	9.88	27.39	60.00	-32.61	QP	
10		7.6403	12.04	9.88	21.92	50.00	-28.08	AVG	
11		17.2162	21.35	9.95	31.30	60.00	-28.70	QP	
12		17.2162	16.14	9.95	26.09	50.00	-23.91	AVG	

REMARKS:

- (1) Measurement Value = Reading Level + Correct Factor.
- (2) Margin Level = Measurement Value - Limit Value.

APPENDIX B RADIATED EMISSIONS - 30 MHZ TO 1 GHZ

Test Mode	UNII-3_IEEE 802.11ax (HE80)	Test Date	2020/7/27
Test Frequency	CH155: 5775 MHz	Polarization	Vertical

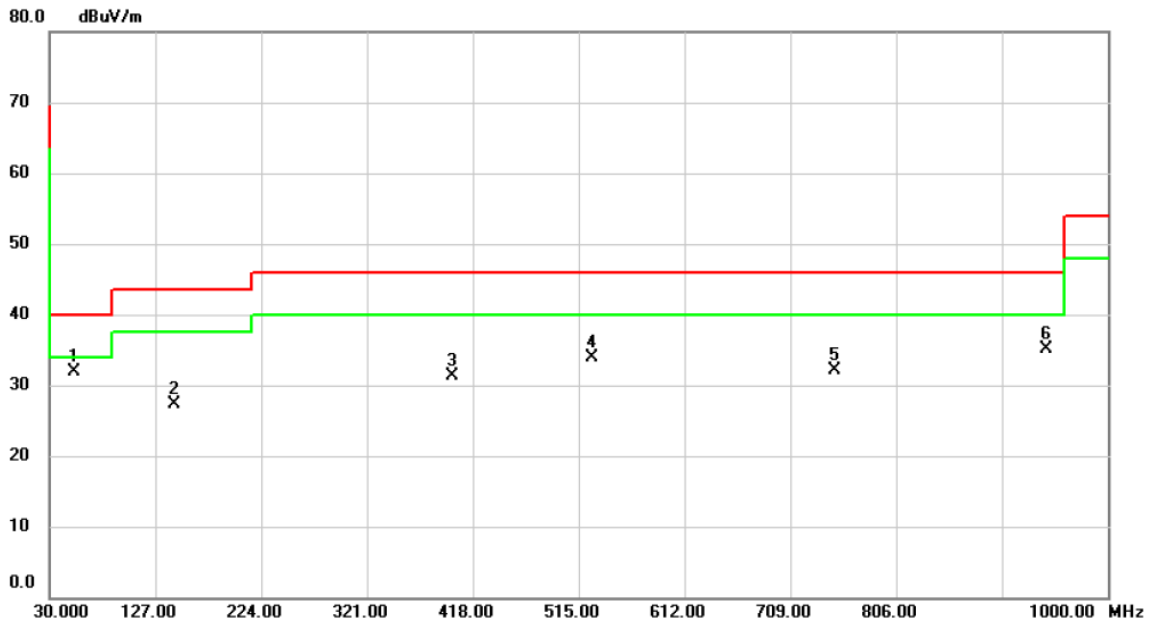

No.	Mk.	Freq. MHz	Reading Level dBuV	Correct Factor dB	Measure- ment dBuV/m	Limit dBuV/m	Over dB	Detector	Comment
1	*	52.3100	39.70	-7.84	31.86	40.00	-8.14	peak	
2		144.4600	35.37	-8.08	27.29	43.50	-16.21	peak	
3		398.6000	36.19	-4.95	31.24	46.00	-14.76	peak	
4		527.6100	35.98	-2.12	33.86	46.00	-12.14	peak	
5		749.7400	29.97	2.13	32.10	46.00	-13.90	peak	
6		943.7400	30.17	4.88	35.05	46.00	-10.95	peak	

REMARKS:

- (1) Measurement Value = Reading Level + Correct Factor.
- (2) Margin Level = Measurement Value - Limit Value.

Test Mode	UNII-3_IEEE 802.11ax (HE80)	Test Date	2020/7/27
Test Frequency	CH155: 5775 MHz	Polarization	Horizontal

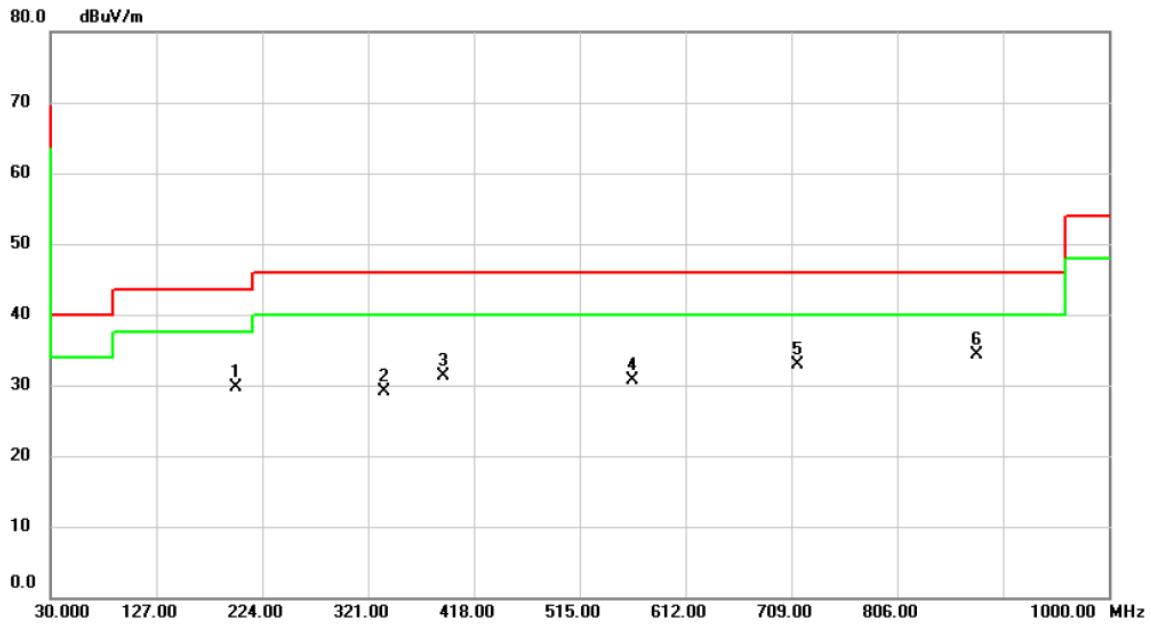

No.	Mk.	Freq. MHz	Reading Level dBuV	Correct Factor dB	Measure- ment dBuV/m	Limit dBuV/m	Over dB	Detector	Comment
1		199.7500	40.37	-10.64	29.73	43.50	-13.77	peak	
2		335.5500	35.36	-6.23	29.13	46.00	-16.87	peak	
3		389.8700	36.46	-5.11	31.35	46.00	-14.65	peak	
4		563.5000	31.99	-1.24	30.75	46.00	-15.25	peak	
5		714.8200	31.40	1.42	32.82	46.00	-13.18	peak	
6	*	878.7500	30.46	3.79	34.25	46.00	-11.75	peak	

REMARKS:

- (1) Measurement Value = Reading Level + Correct Factor.
- (2) Margin Level = Measurement Value - Limit Value.

APPENDIX C RADIATED EMISSIONS - ABOVE 1 GHZ

Test Mode	UNII-1_IEEE 802.11a	Test Date	2020/7/25
Test Frequency	CH36: 5180 MHz	Polarization	Vertical

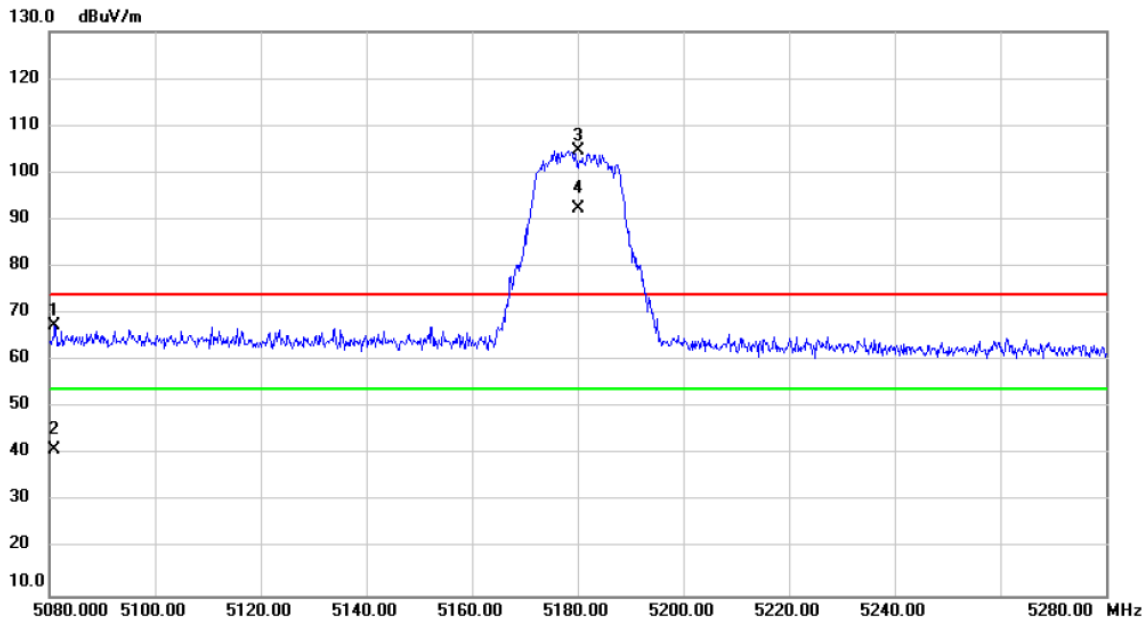

No.	Mk.	Freq.	Reading Level	Correct Factor	Measurement	Limit	Over	Detector	Comment
		MHz	dBuV	dB	dBuV/m	dBuV/m	dB		
1		5081.000	30.13	37.24	67.37	74.00	-6.63	peak	
2		5081.000	3.75	37.24	40.99	54.00	-13.01	AVG	
3	X	5180.000	67.32	37.33	104.65	74.00	30.65	peak	No Limit
4	*	5180.000	55.03	37.33	92.36	54.00	38.36	AVG	No Limit

REMARKS:

- (1) Measurement Value = Reading Level + Correct Factor.
- (2) Margin Level = Measurement Value - Limit Value.

Test Mode	UNII-1_IEEE 802.11a	Test Date	2020/7/25
Test Frequency	CH48: 5240 MHz	Polarization	Vertical

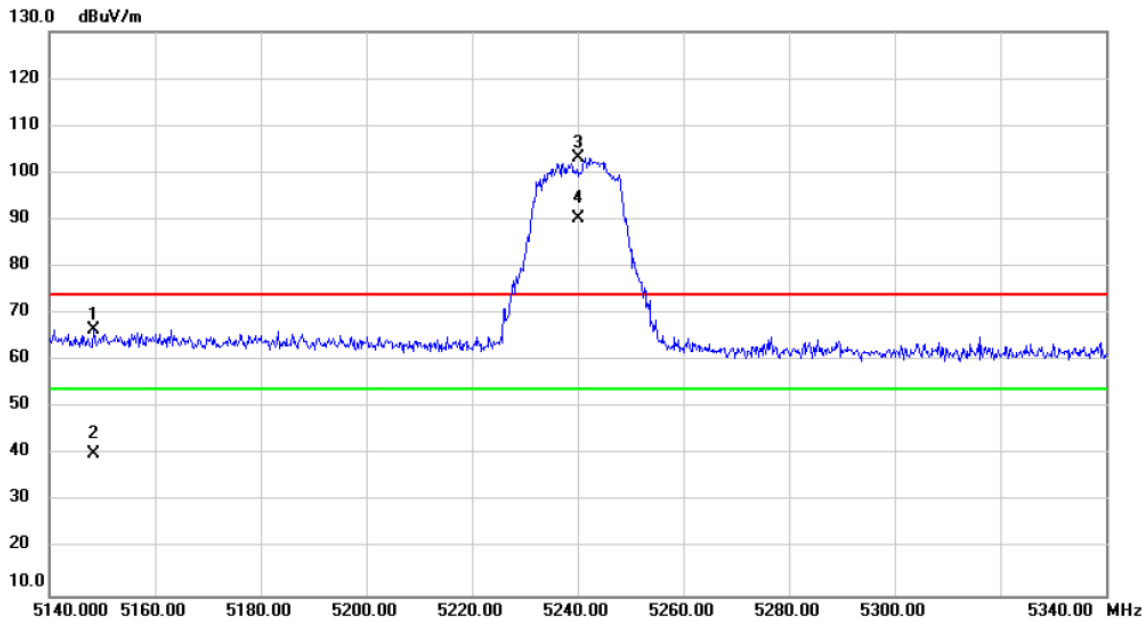

No.	Mk.	Freq.	Reading Level	Correct Factor	Measurement	Limit	Over	Detector	Comment
		MHz	dBuV	dB	dBuV/m	dBuV/m	dB		
1		5148.400	29.33	37.30	66.63	74.00	-7.37	peak	
2		5148.400	2.74	37.30	40.04	54.00	-13.96	AVG	
3	X	5240.000	65.88	37.38	103.26	74.00	29.26	peak	No Limit
4	*	5240.000	52.79	37.38	90.17	54.00	36.17	AVG	No Limit

REMARKS:

- (1) Measurement Value = Reading Level + Correct Factor.
- (2) Margin Level = Measurement Value - Limit Value.

Test Mode	UNII-2A_IEEE 802.11a	Test Date	2020/7/25
Test Frequency	CH52: 5260 MHz	Polarization	Vertical

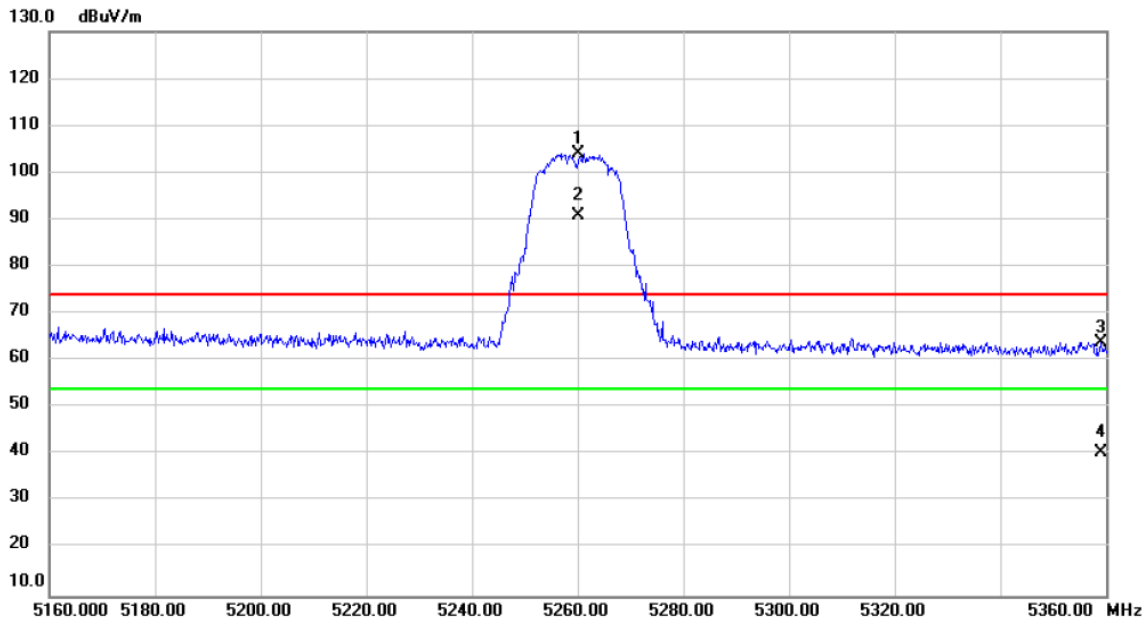

No.	Mk.	Freq.	Reading Level	Correct Factor	Measurement	Limit	Over	Detector	Comment
		MHz	dBuV	dB	dBuV/m	dBuV/m	dB		
1	X	5260.000	66.68	37.40	104.08	74.00	30.08	peak	No Limit
2	*	5260.000	53.55	37.40	90.95	54.00	36.95	AVG	No Limit
3		5359.000	26.47	37.49	63.96	74.00	-10.04	peak	
4		5359.000	3.08	37.49	40.57	54.00	-13.43	AVG	

REMARKS:

- (1) Measurement Value = Reading Level + Correct Factor.
- (2) Margin Level = Measurement Value - Limit Value.

Test Mode	UNII-2A_ IEEE 802.11a	Test Date	2020/7/25
Test Frequency	CH64: 5320 MHz	Polarization	Vertical

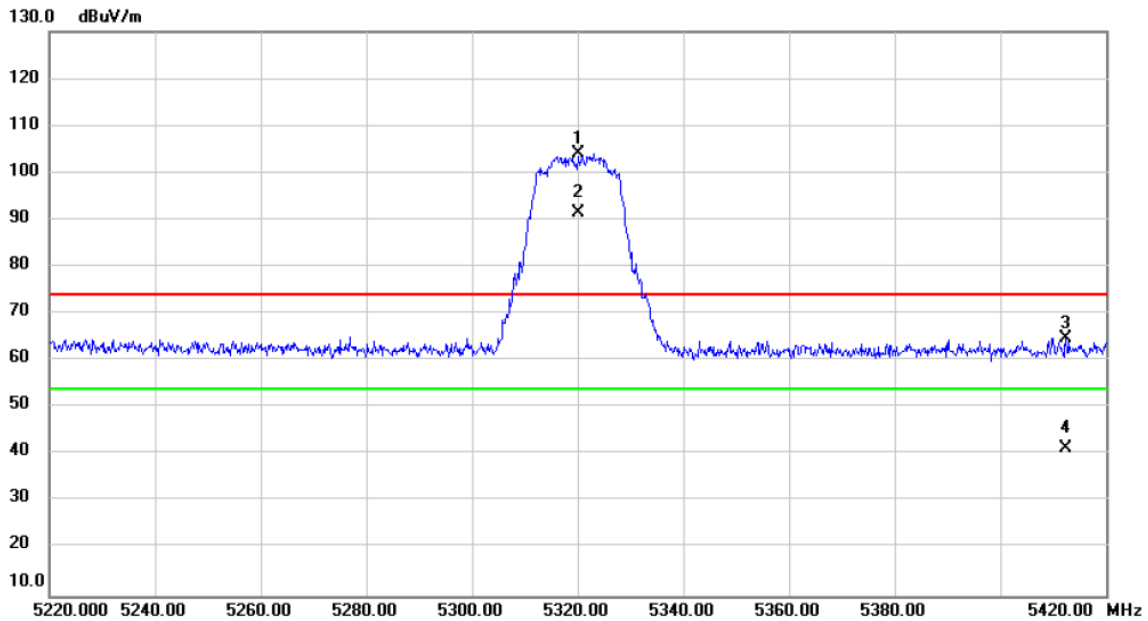

No.	Mk.	Freq.	Reading Level	Correct Factor	Measurement	Limit	Over	Detector	Comment
		MHz	dBuV	dB	dBuV/m	dBuV/m	dB		
1	X	5320.000	66.59	37.45	104.04	74.00	30.04	peak	No Limit
2	*	5320.000	53.86	37.45	91.31	54.00	37.31	AVG	No Limit
3		5412.400	27.30	37.54	64.84	74.00	-9.16	peak	
4		5412.400	3.89	37.54	41.43	54.00	-12.57	AVG	

REMARKS:

- (1) Measurement Value = Reading Level + Correct Factor.
- (2) Margin Level = Measurement Value - Limit Value.

Test Mode	UNII-2C_IEEE 802.11a	Test Date	2020/7/25
Test Frequency	CH100: 5500 MHz	Polarization	Vertical

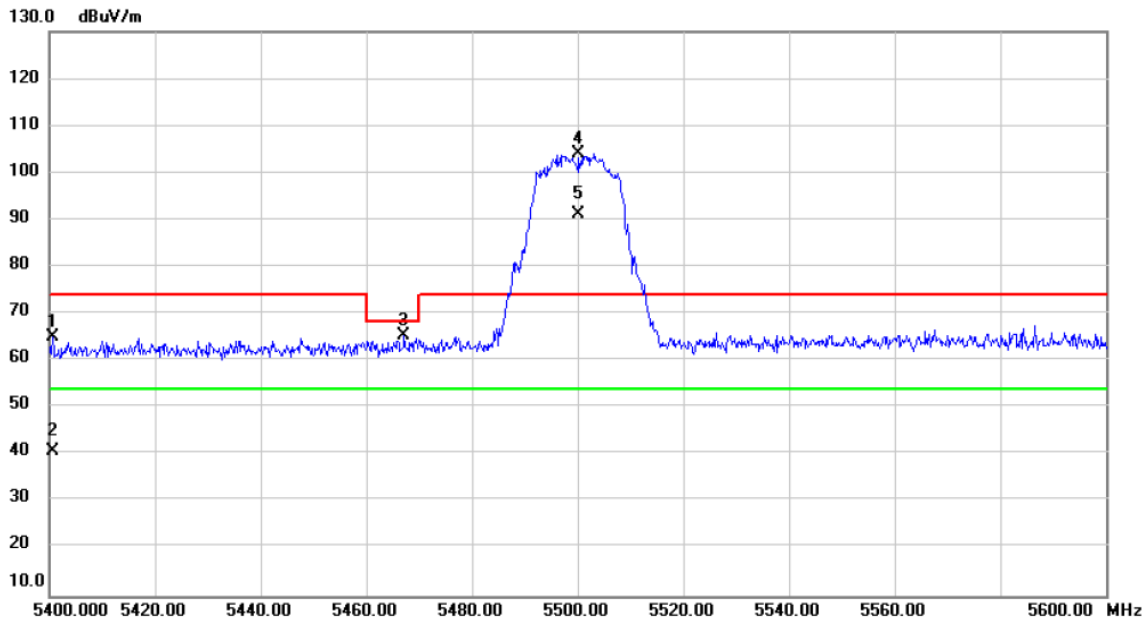

No.	Mk.	Freq.	Reading Level	Correct Factor	Measurement	Limit	Over	Detector	Comment
		MHz	dBuV	dB	dBuV/m	dBuV/m	dB		
1		5400.600	27.42	37.52	64.94	74.00	-9.06	peak	
2		5400.600	3.10	37.52	40.62	54.00	-13.38	AVG	
3		5467.200	27.64	37.58	65.22	68.20	-2.98	peak	
4	X	5500.000	66.33	37.61	103.94	74.00	29.94	peak	No Limit
5	*	5500.000	53.40	37.61	91.01	54.00	37.01	AVG	No Limit

REMARKS:

- (1) Measurement Value = Reading Level + Correct Factor.
- (2) Margin Level = Measurement Value - Limit Value.

Test Mode	UNII-2C_IEEE 802.11a	Test Date	2020/7/25
Test Frequency	CH140: 5700 MHz	Polarization	Vertical

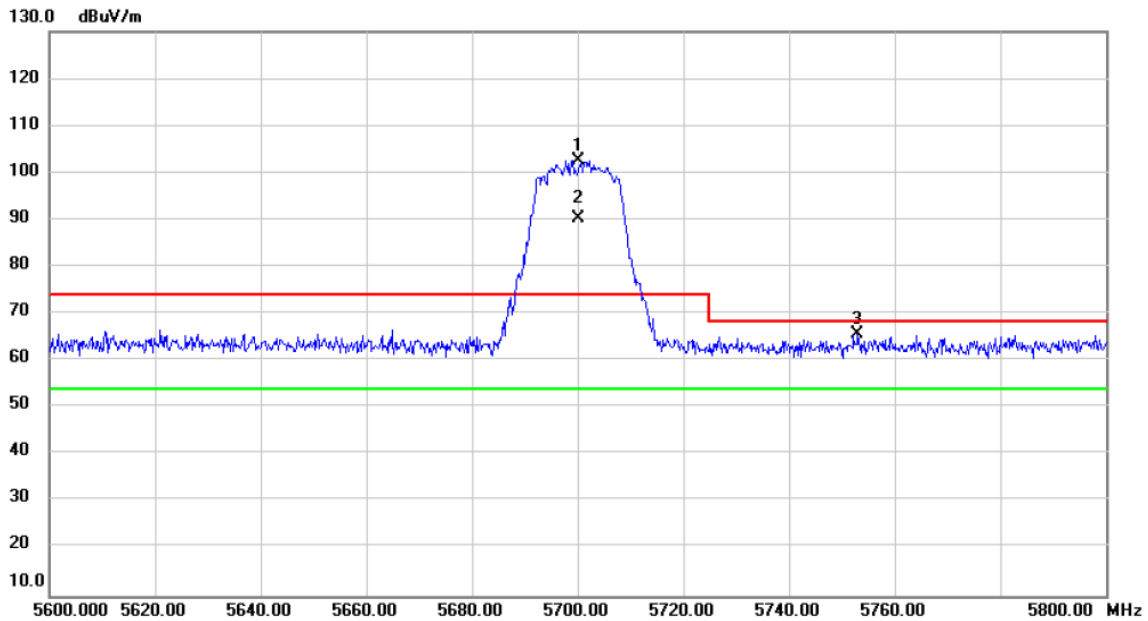

No.	Mk.	Freq.	Reading Level	Correct Factor	Measurement	Limit	Over	Detector	Comment
		MHz	dBuV	dB	dBuV/m	dBuV/m	dB		
1	X	5700.000	64.57	38.04	102.61	74.00	28.61	peak	No Limit
2	*	5700.000	52.24	38.04	90.28	54.00	36.28	AVG	No Limit
3		5753.000	27.36	38.15	65.51	68.20	-2.69	peak	

REMARKS:

- (1) Measurement Value = Reading Level + Correct Factor.
- (2) Margin Level = Measurement Value - Limit Value.

Test Mode	UNII-3_IIEEE 802.11a	Test Date	2020/7/25
Test Frequency	CH149: 5745 MHz	Polarization	Vertical

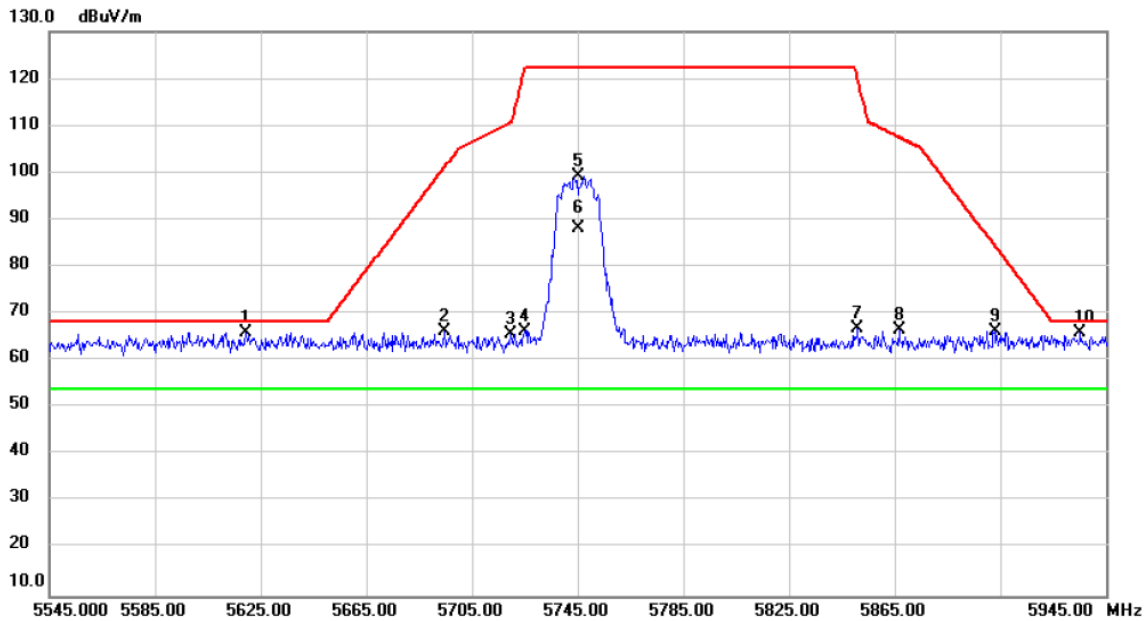

No. Mk.	Freq. MHz	Reading Level dBuV	Correct Factor dB	Measurement dBuV/m	Limit dBuV/m	Over dB	Detector	Comment
1	5619.400	28.17	37.86	66.03	68.20	-2.17	peak	
2	5694.600	28.24	38.02	66.26	101.22	-34.96	peak	
3	5719.800	27.65	38.08	65.73	110.74	-45.01	peak	
4	5725.000	28.28	38.09	66.37	122.20	-55.83	peak	
5	5745.000	61.02	38.13	99.15	122.20	-23.05	peak	No Limit
6 *	5745.000	49.95	38.13	88.08	54.00	34.08	AVG	No Limit
7	5851.000	28.55	38.36	66.91	119.92	-53.01	peak	
8	5866.600	28.13	38.39	66.52	107.55	-41.03	peak	
9	5903.000	27.77	38.47	66.24	84.44	-18.20	peak	
10	5935.400	27.47	38.54	66.01	68.20	-2.19	peak	

REMARKS:

- (1) Measurement Value = Reading Level + Correct Factor.
- (2) Margin Level = Measurement Value - Limit Value.

Test Mode	UNII-3_IEEE 802.11a	Test Date	2020/7/25
Test Frequency	CH165: 5825 MHz	Polarization	Vertical

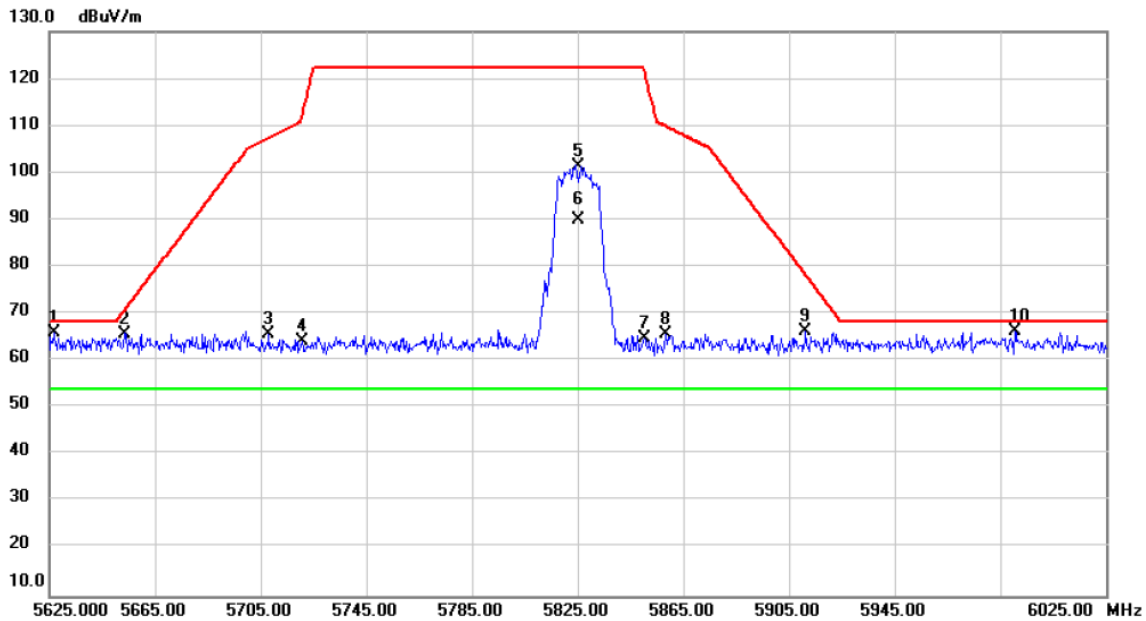

No.	Mk.	Freq.	Reading Level	Correct Factor	Measurement	Limit	Over	Detector	Comment
		MHz	dBuV	dB	dBuV/m	dBuV/m	dB		
1		5626.600	28.06	37.88	65.94	68.20	-2.26	peak	
2		5653.400	27.87	37.93	65.80	70.73	-4.93	peak	
3		5708.200	27.54	38.06	65.60	107.50	-41.90	peak	
4		5720.600	26.14	38.08	64.22	112.17	-47.95	peak	
5		5825.000	63.19	38.31	101.50	122.20	-20.70	peak	No Limit
6	*	5825.000	51.59	38.31	89.90	54.00	35.90	AVG	No Limit
7		5850.200	26.49	38.36	64.85	121.74	-56.89	peak	
8		5858.200	27.32	38.38	65.70	109.90	-44.20	peak	
9		5911.400	27.69	38.49	66.18	78.23	-12.05	peak	
10		5990.600	27.53	38.66	66.19	68.20	-2.01	peak	

REMARKS:

- (1) Measurement Value = Reading Level + Correct Factor.
- (2) Margin Level = Measurement Value - Limit Value.

Test Mode	UNII-1_IEEE 802.11ac (VHT20)	Test Date	2020/7/25
Test Frequency	CH36: 5180 MHz	Polarization	Vertical

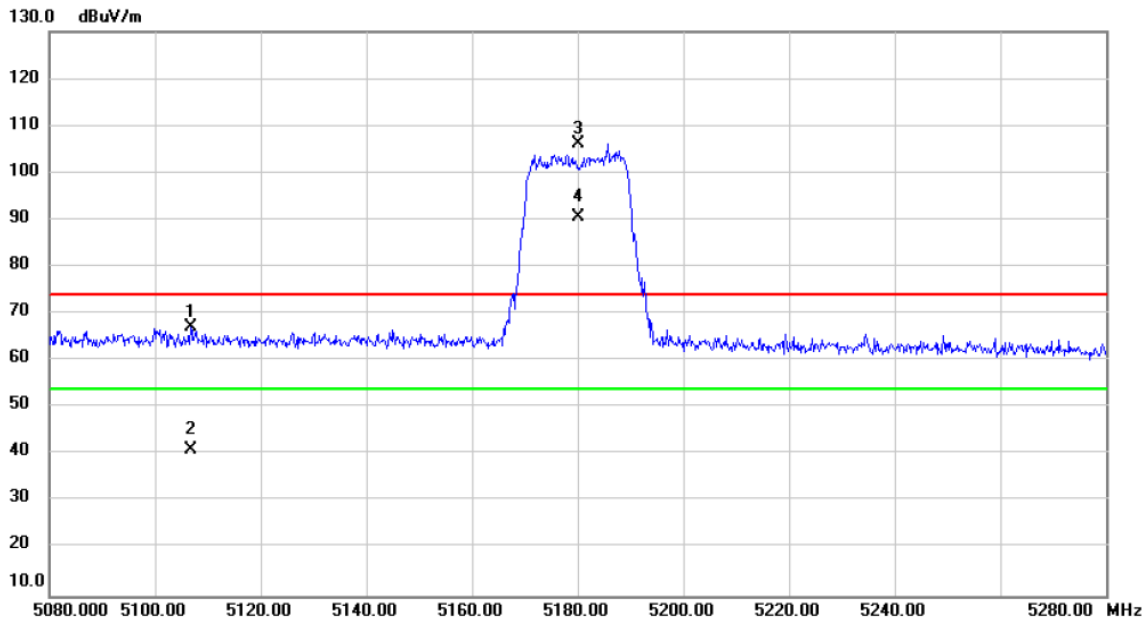

No.	Mk.	Freq.	Reading Level	Correct Factor	Measurement	Limit	Over	Detector	Comment
		MHz	dBuV	dB	dBuV/m	dBuV/m	dB		
1		5106.800	29.79	37.26	67.05	74.00	-6.95	peak	
2		5106.800	3.65	37.26	40.91	54.00	-13.09	AVG	
3	X	5180.000	68.90	37.33	106.23	74.00	32.23	peak	No Limit
4	*	5180.000	53.37	37.33	90.70	54.00	36.70	AVG	No Limit

REMARKS:

- (1) Measurement Value = Reading Level + Correct Factor.
- (2) Margin Level = Measurement Value - Limit Value.

Test Mode	UNII-1_IEEE 802.11ac (VHT20)	Test Date	2020/7/25
Test Frequency	CH48: 5240 MHz	Polarization	Vertical

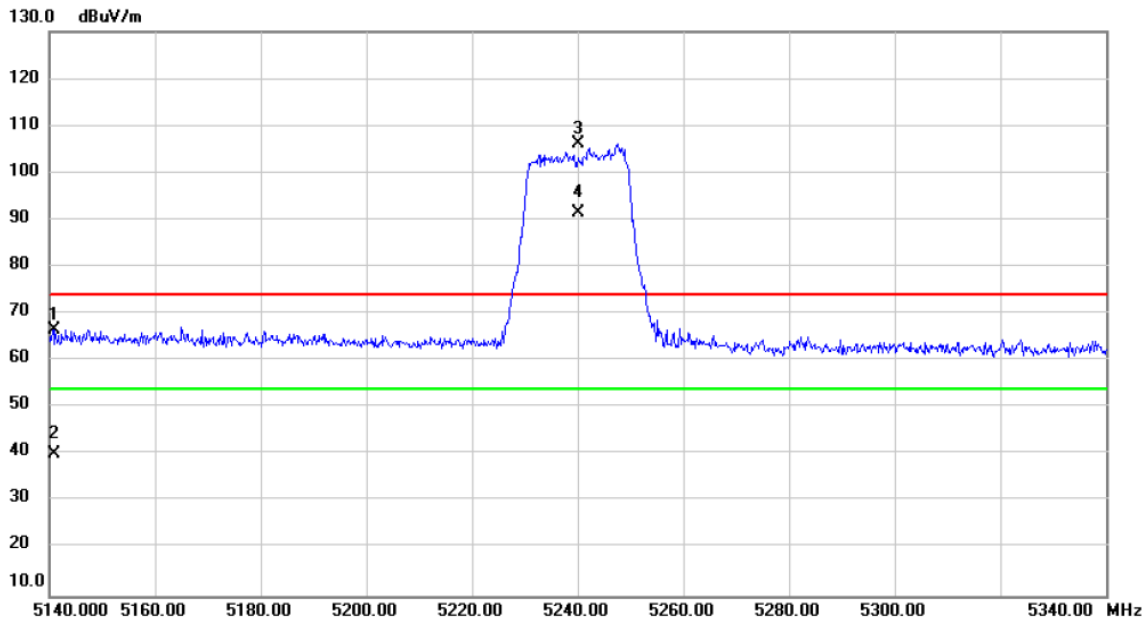

No.	Mk.	Freq.	Reading Level	Correct Factor	Measurement	Limit	Over	Detector	Comment
		MHz	dBuV	dB	dBuV/m	dBuV/m	dB		
1		5140.800	29.29	37.29	66.58	74.00	-7.42	peak	
2		5140.800	2.90	37.29	40.19	54.00	-13.81	AVG	
3	X	5240.000	68.80	37.38	106.18	74.00	32.18	peak	No Limit
4	*	5240.000	53.96	37.38	91.34	54.00	37.34	AVG	No Limit

REMARKS:

- (1) Measurement Value = Reading Level + Correct Factor.
- (2) Margin Level = Measurement Value - Limit Value.

Test Mode	UNII-2A_IEEE 802.11ac (VHT20)	Test Date	2020/7/25
Test Frequency	CH52: 5260 MHz	Polarization	Vertical

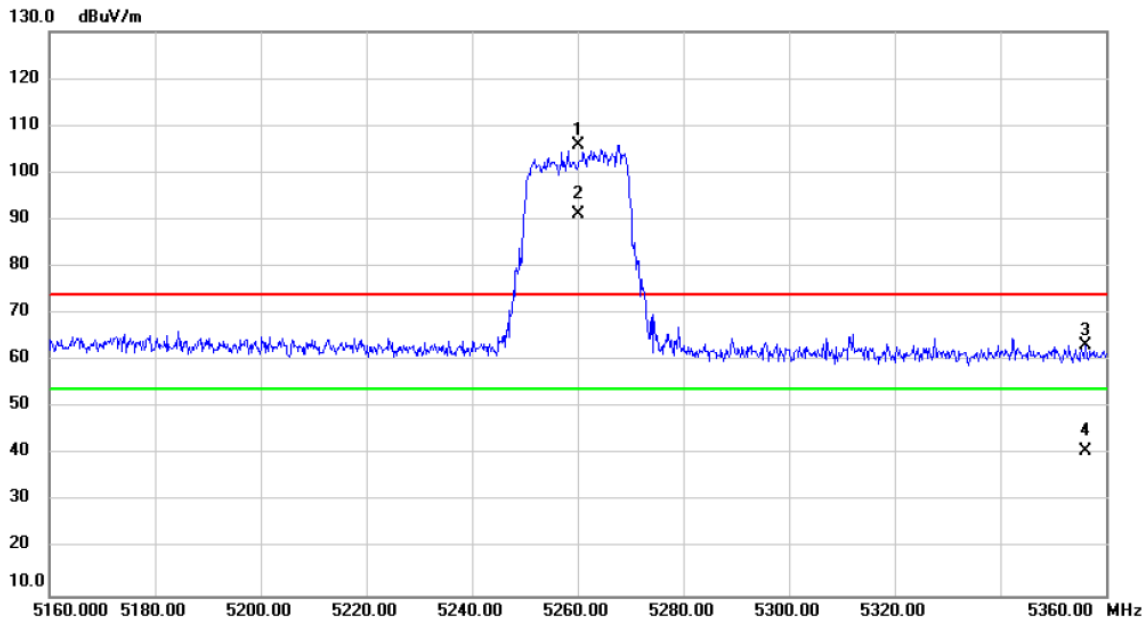

No.	Mk.	Freq.	Reading Level	Correct Factor	Measurement	Limit	Over	Detector	Comment
		MHz	dBuV	dB	dBuV/m	dBuV/m	dB		
1	X	5260.000	68.44	37.40	105.84	74.00	31.84	peak	No Limit
2	*	5260.000	53.85	37.40	91.25	54.00	37.25	AVG	No Limit
3		5356.200	25.91	37.48	63.39	74.00	-10.61	peak	
4		5356.200	3.32	37.48	40.80	54.00	-13.20	AVG	

REMARKS:

- (1) Measurement Value = Reading Level + Correct Factor.
- (2) Margin Level = Measurement Value - Limit Value.

Test Mode	UNII-2A_IEEE 802.11ac (VHT20)	Test Date	2020/7/25
Test Frequency	CH64: 5320 MHz	Polarization	Vertical

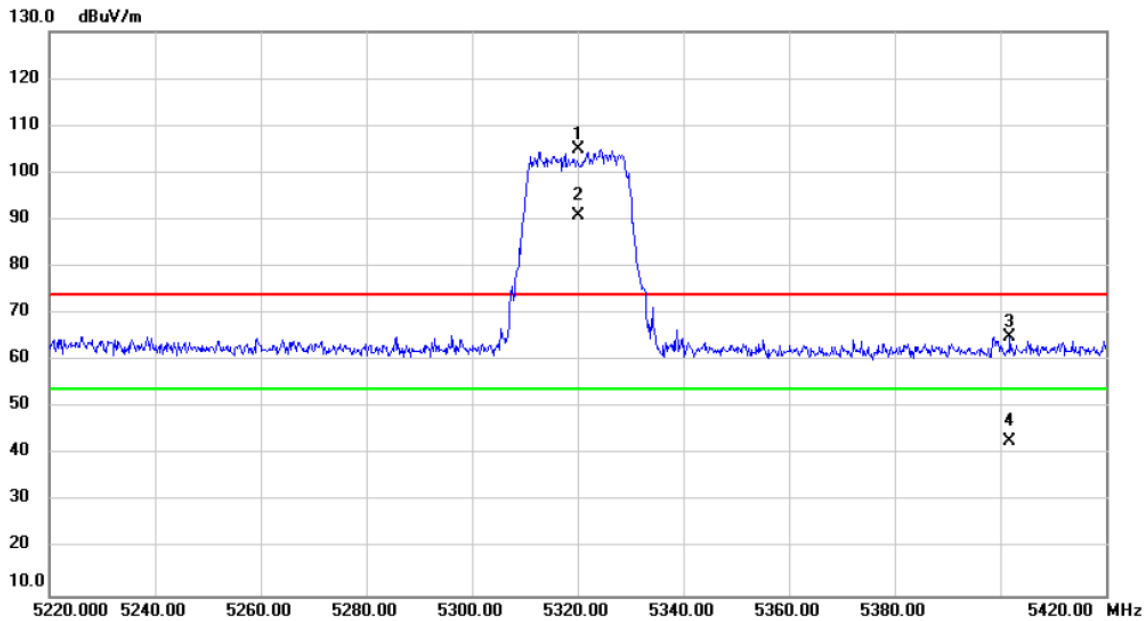

No.	Mk.	Freq.	Reading Level	Correct Factor	Measurement	Limit	Over	Detector	Comment
		MHz	dBuV	dB	dBuV/m	dBuV/m	dB		
1	X	5320.000	67.38	37.45	104.83	74.00	30.83	peak	No Limit
2	*	5320.000	53.42	37.45	90.87	54.00	36.87	AVG	No Limit
3		5401.800	27.43	37.52	64.95	74.00	-9.05	peak	
4		5401.800	5.24	37.52	42.76	54.00	-11.24	AVG	

REMARKS:

- (1) Measurement Value = Reading Level + Correct Factor.
- (2) Margin Level = Measurement Value - Limit Value.

Test Mode	UNII-2C_IEEE 802.11ac (VHT20)	Test Date	2020/7/25
Test Frequency	CH100: 5500 MHz	Polarization	Vertical

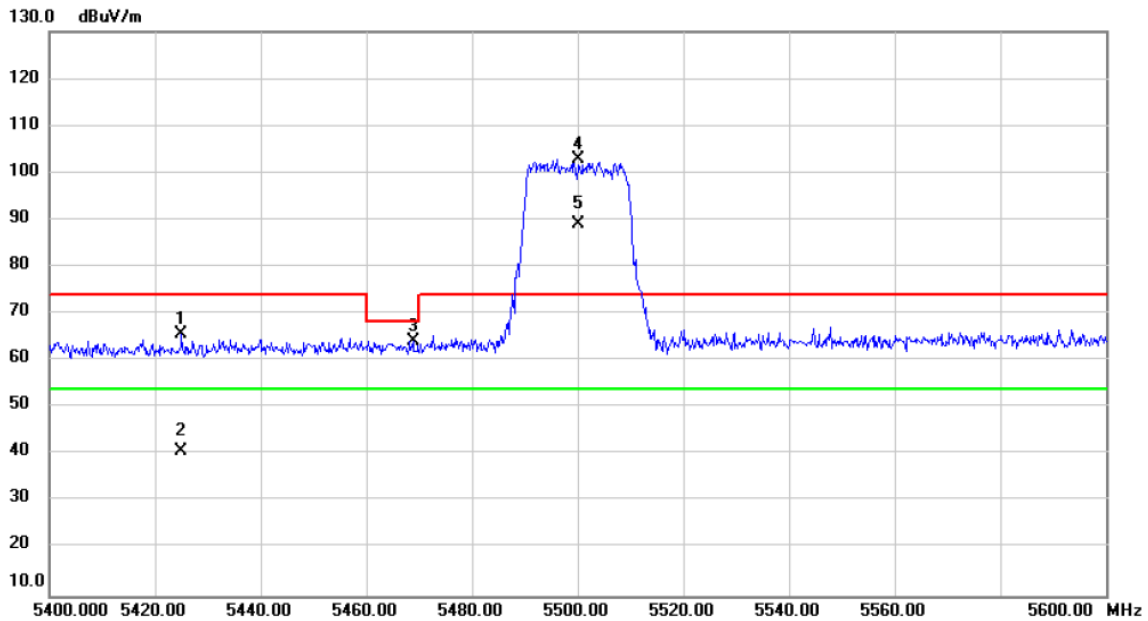

No.	Mk.	Freq.	Reading Level	Correct Factor	Measurement	Limit	Over	Detector	Comment
		MHz	dBuV	dB	dBuV/m	dBuV/m	dB		
1		5425.000	27.97	37.54	65.51	74.00	-8.49	peak	
2		5425.000	3.26	37.54	40.80	54.00	-13.20	AVG	
3		5468.800	26.69	37.58	64.27	68.20	-3.93	peak	
4	X	5500.000	65.23	37.61	102.84	74.00	28.84	peak	No Limit
5	*	5500.000	51.46	37.61	89.07	54.00	35.07	AVG	No Limit

REMARKS:

- (1) Measurement Value = Reading Level + Correct Factor.
- (2) Margin Level = Measurement Value - Limit Value.

Test Mode	UNII-2C_IEEE 802.11ac (VHT20)	Test Date	2020/7/25
Test Frequency	CH140: 5700 MHz	Polarization	Vertical

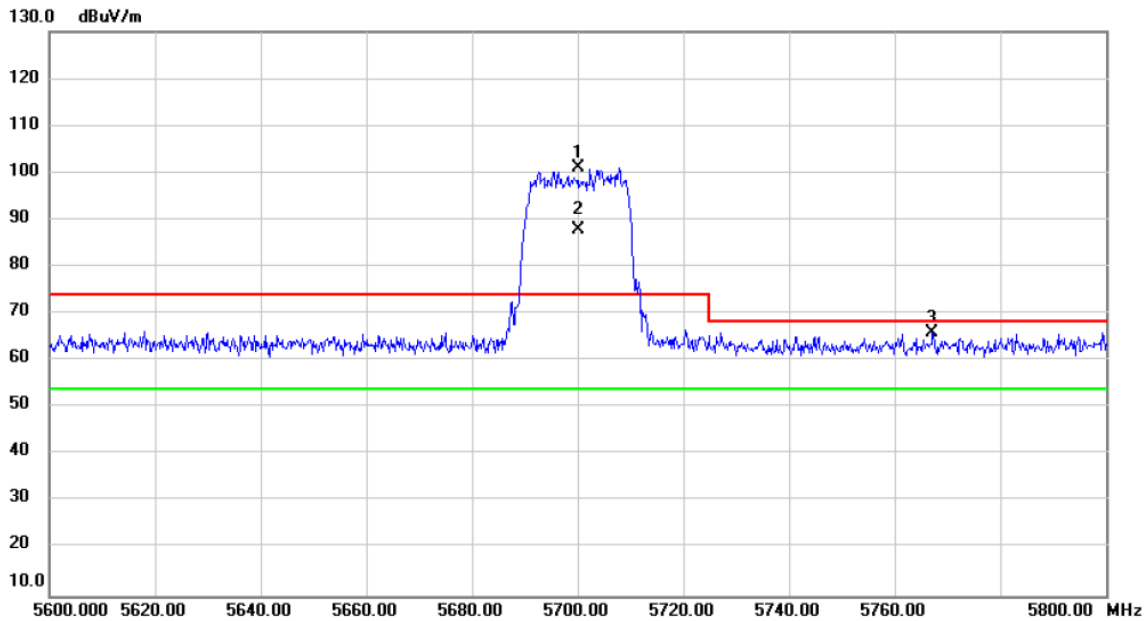

No.	Mk.	Freq.	Reading Level	Correct Factor	Measurement	Limit	Over	Detector	Comment
		MHz	dBuV	dB	dBuV/m	dBuV/m	dB		
1	X	5700.000	62.98	38.04	101.02	74.00	27.02	peak	No Limit
2	*	5700.000	49.81	38.04	87.85	54.00	33.85	AVG	No Limit
3		5767.200	27.70	38.18	65.88	68.20	-2.32	peak	

REMARKS:

- (1) Measurement Value = Reading Level + Correct Factor.
- (2) Margin Level = Measurement Value - Limit Value.

Test Mode	UNII-3_IEEE 802.11ac (VHT20)	Test Date	2020/7/25
Test Frequency	CH149: 5745 MHz	Polarization	Vertical

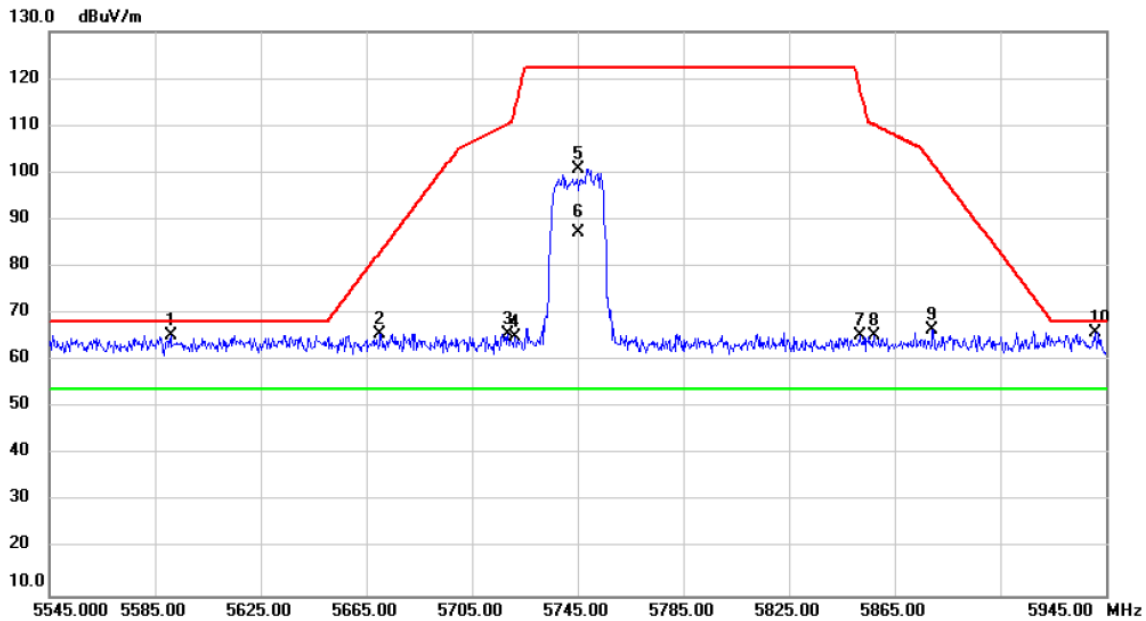

No.	Mk.	Freq. MHz	Reading Level dBuV	Correct Factor dB	Measure- ment dBuV/m	Limit dBuV/m	Over dB	Detector	Comment
1		5591.000	27.67	37.81	65.48	68.20	-2.72	peak	
2		5670.200	27.82	37.97	65.79	83.19	-17.40	peak	
3		5718.600	27.66	38.08	65.74	110.41	-44.67	peak	
4		5721.400	26.84	38.09	64.93	113.99	-49.06	peak	
5		5745.000	62.53	38.13	100.66	122.20	-21.54	peak	No Limit
6	*	5745.000	49.21	38.13	87.34	54.00	33.34	AVG	No Limit
7		5851.800	27.09	38.36	65.45	118.09	-52.64	peak	
8		5857.000	26.95	38.38	65.33	110.24	-44.91	peak	
9		5879.400	28.07	38.43	66.50	101.93	-35.43	peak	
10		5941.000	27.39	38.55	65.94	68.20	-2.26	peak	

REMARKS:

- (1) Measurement Value = Reading Level + Correct Factor.
- (2) Margin Level = Measurement Value - Limit Value.

Test Mode	UNII-3_IEEE 802.11ac (VHT20)	Test Date	2020/7/25
Test Frequency	CH165: 5825 MHz	Polarization	Vertical

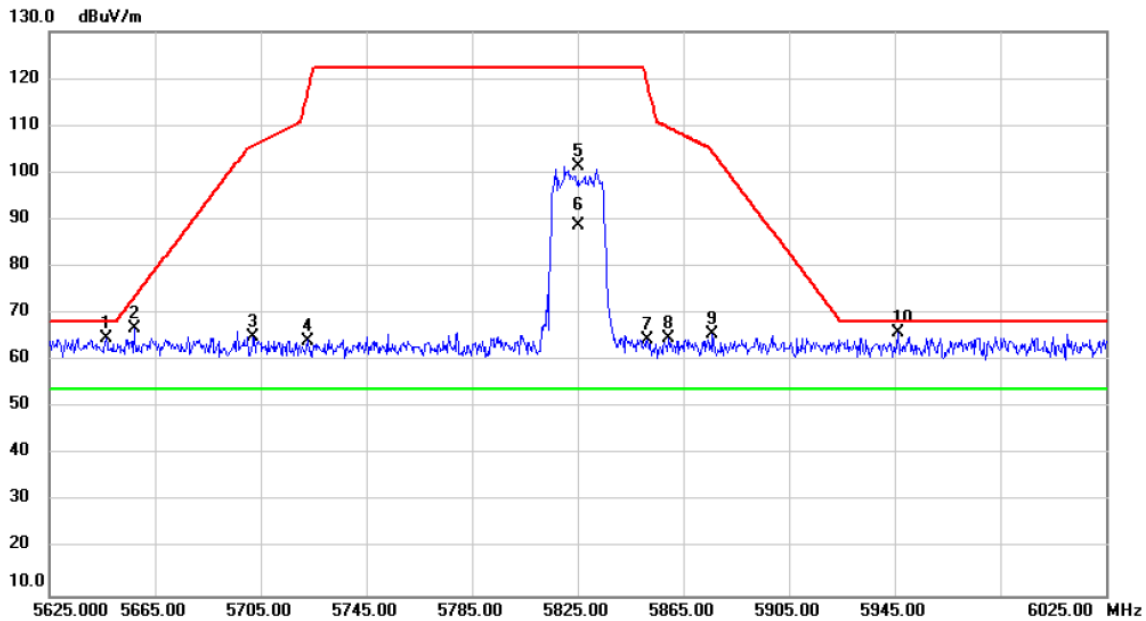

No.	Mk.	Freq.	Reading Level	Correct Factor	Measurement	Limit	Over	Detector	Comment
		MHz	dBuV	dB	dBuV/m	dBuV/m	dB		
1		5646.600	26.85	37.93	64.78	68.20	-3.42	peak	
2		5657.000	28.85	37.95	66.80	73.40	-6.60	peak	
3		5702.200	26.99	38.04	65.03	105.82	-40.79	peak	
4		5722.600	26.21	38.09	64.30	116.73	-52.43	peak	
5		5825.000	63.03	38.31	101.34	122.20	-20.86	peak	No Limit
6	*	5825.000	50.34	38.31	88.65	54.00	34.65	AVG	No Limit
7		5851.400	26.08	38.36	64.44	119.01	-54.57	peak	
8		5859.400	26.50	38.38	64.88	109.57	-44.69	peak	
9		5876.200	27.35	38.41	65.76	104.31	-38.55	peak	
10		5946.200	27.29	38.57	65.86	68.20	-2.34	peak	

REMARKS:

- (1) Measurement Value = Reading Level + Correct Factor.
- (2) Margin Level = Measurement Value - Limit Value.

Test Mode	UNII-1_IEEE 802.11ac (VHT40)	Test Date	2020/7/25
Test Frequency	CH38: 5190 MHz	Polarization	Vertical

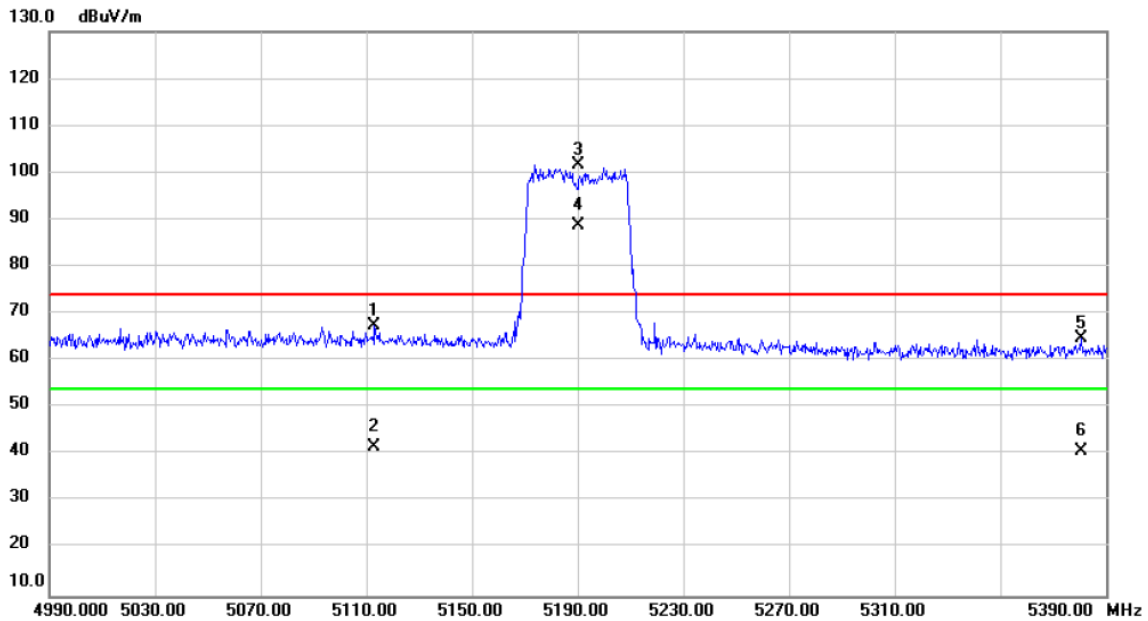

No.	Mk.	Freq.	Reading Level	Correct Factor	Measurement	Limit	Over	Detector	Comment
		MHz	dBuV	dB	dBuV/m	dBuV/m	dB		
1		5113.200	30.23	37.27	67.50	74.00	-6.50	peak	
2		5113.200	4.49	37.27	41.76	54.00	-12.24	AVG	
3	X	5190.000	64.42	37.33	101.75	74.00	27.75	peak	No Limit
4	*	5190.000	51.47	37.33	88.80	54.00	34.80	AVG	No Limit
5		5380.800	27.27	37.51	64.78	74.00	-9.22	peak	
6		5380.800	3.13	37.51	40.64	54.00	-13.36	AVG	

REMARKS:

- (1) Measurement Value = Reading Level + Correct Factor.
- (2) Margin Level = Measurement Value - Limit Value.

Test Mode	UNII-1_IEEE 802.11ac (VHT40)	Test Date	2020/7/25
Test Frequency	CH46: 5230 MHz	Polarization	Vertical

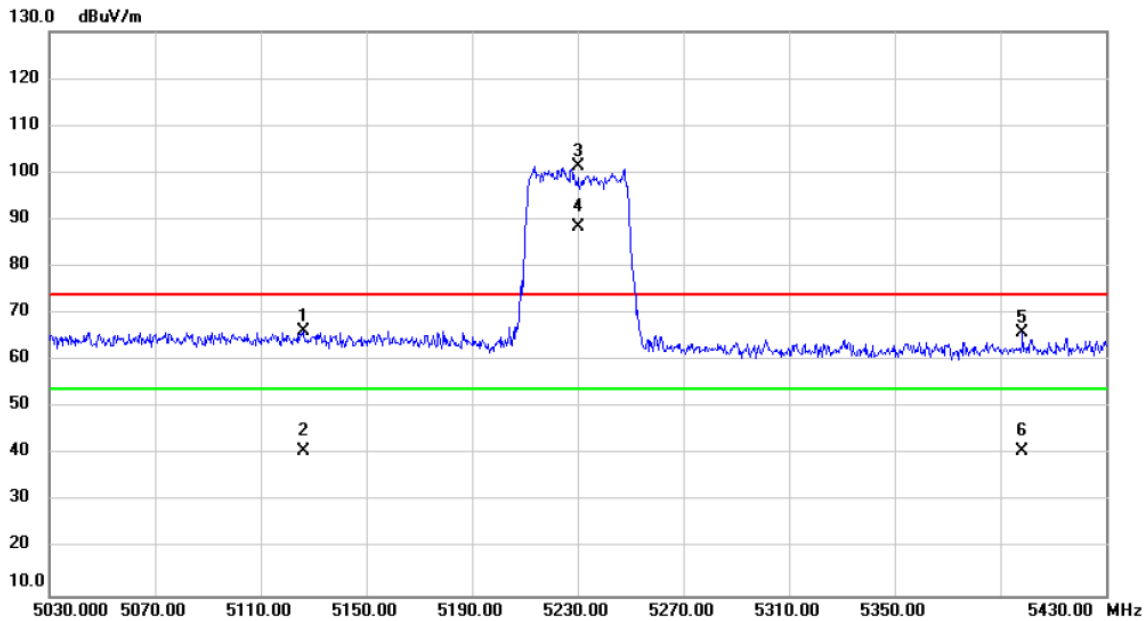

No.	Mk.	Freq.	Reading Level	Correct Factor	Measurement	Limit	Over	Detector	Comment
		MHz	dBuV	dB	dBuV/m	dBuV/m	dB		
1		5126.000	28.85	37.29	66.14	74.00	-7.86	peak	
2		5126.000	3.46	37.29	40.75	54.00	-13.25	AVG	
3	X	5230.000	64.09	37.37	101.46	74.00	27.46	peak	No Limit
4	*	5230.000	51.01	37.37	88.38	54.00	34.38	AVG	No Limit
5		5398.400	28.52	37.52	66.04	74.00	-7.96	peak	
6		5398.400	3.17	37.52	40.69	54.00	-13.31	AVG	

REMARKS:

- (1) Measurement Value = Reading Level + Correct Factor.
- (2) Margin Level = Measurement Value - Limit Value.

Test Mode	UNII-2A_ IEEE 802.11ac (VHT40)	Test Date	2020/7/25
Test Frequency	CH54: 5270 MHz	Polarization	Vertical

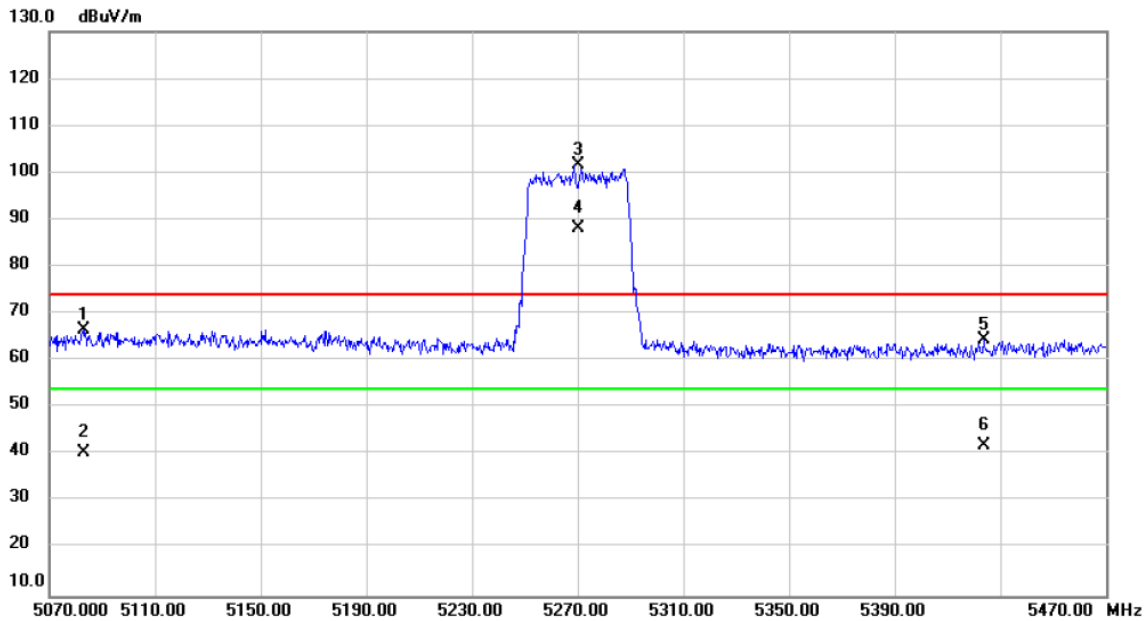

No.	Mk.	Freq.	Reading Level	Correct Factor	Measurement	Limit	Over	Detector	Comment
		MHz	dBuV	dB	dBuV/m	dBuV/m	dB		
1		5083.200	29.18	37.24	66.42	74.00	-7.58	peak	
2		5083.200	3.22	37.24	40.46	54.00	-13.54	AVG	
3	X	5270.000	64.14	37.41	101.55	74.00	27.55	peak	No Limit
4	*	5270.000	50.81	37.41	88.22	54.00	34.22	AVG	No Limit
5		5423.600	26.84	37.54	64.38	74.00	-9.62	peak	
6		5423.600	4.48	37.54	42.02	54.00	-11.98	AVG	

REMARKS:

- (1) Measurement Value = Reading Level + Correct Factor.
- (2) Margin Level = Measurement Value - Limit Value.

Test Mode	UNII-2A_ IEEE 802.11ac (VHT40)	Test Date	2020/7/25
Test Frequency	CH62: 5310 MHz	Polarization	Vertical

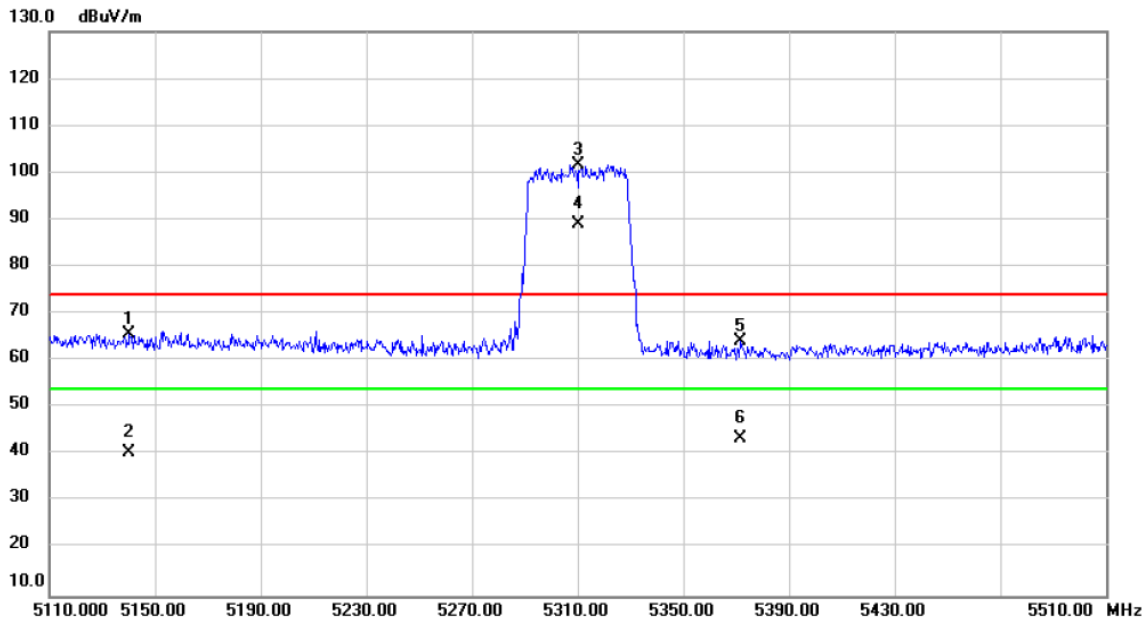

No.	Mk.	Freq.	Reading Level	Correct Factor	Measurement	Limit	Over	Detector	Comment
		MHz	dBuV	dB	dBuV/m	dBuV/m	dB		
1	X	5140.400	28.43	37.29	65.72	74.00	-8.28	peak	
2		5140.400	3.24	37.29	40.53	54.00	-13.47	AVG	
3	X	5310.000	64.29	37.45	101.74	74.00	27.74	peak	No Limit
4	*	5310.000	51.63	37.45	89.08	54.00	35.08	AVG	No Limit
5		5371.600	26.77	37.49	64.26	74.00	-9.74	peak	
6	X	5371.600	5.93	37.49	43.42	54.00	-10.58	AVG	

REMARKS:

- (1) Measurement Value = Reading Level + Correct Factor.
- (2) Margin Level = Measurement Value - Limit Value.

Test Mode	UNII-2C_IEEE 802.11ac (VHT40)	Test Date	2020/7/25
Test Frequency	CH102: 5510 MHz	Polarization	Vertical

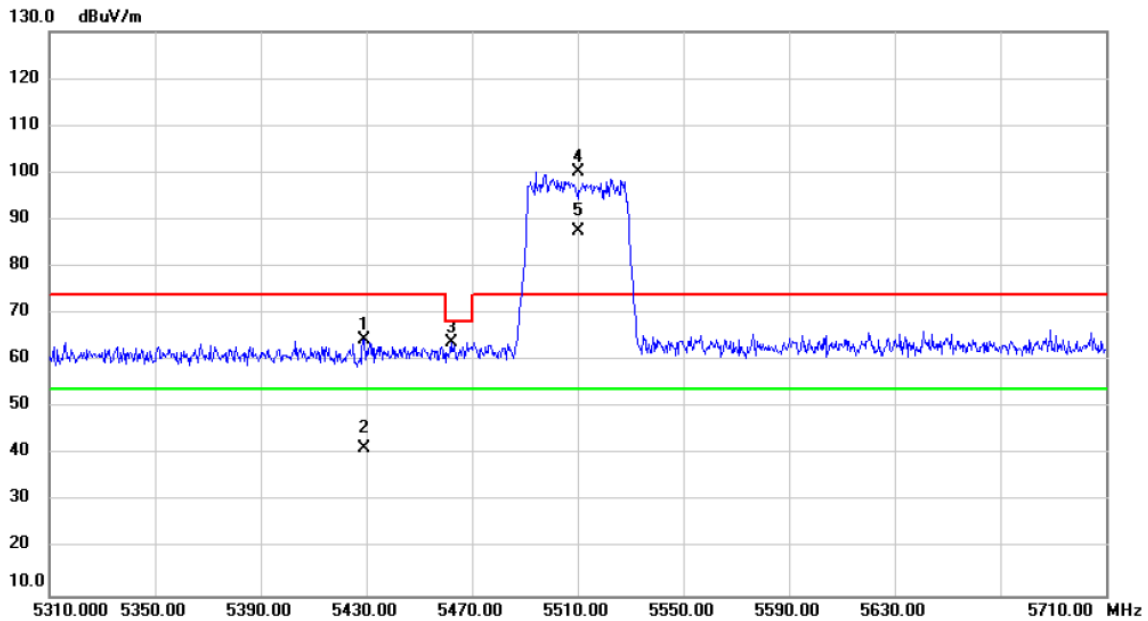

No.	Mk.	Freq.	Reading Level	Correct Factor	Measurement	Limit	Over	Detector	Comment
		MHz	dBuV	dB	dBuV/m	dBuV/m	dB		
1		5429.200	26.97	37.55	64.52	74.00	-9.48	peak	
2		5429.200	3.87	37.55	41.42	54.00	-12.58	AVG	
3		5462.000	26.33	37.58	63.91	68.20	-4.29	peak	
4	X	5510.000	62.53	37.63	100.16	74.00	26.16	peak	No Limit
5	*	5510.000	49.81	37.63	87.44	54.00	33.44	AVG	No Limit

REMARKS:

- (1) Measurement Value = Reading Level + Correct Factor.
- (2) Margin Level = Measurement Value - Limit Value.

Test Mode	UNII-2C_IEEE 802.11ac (VHT40)	Test Date	2020/7/25
Test Frequency	CH134: 5670 MHz	Polarization	Vertical

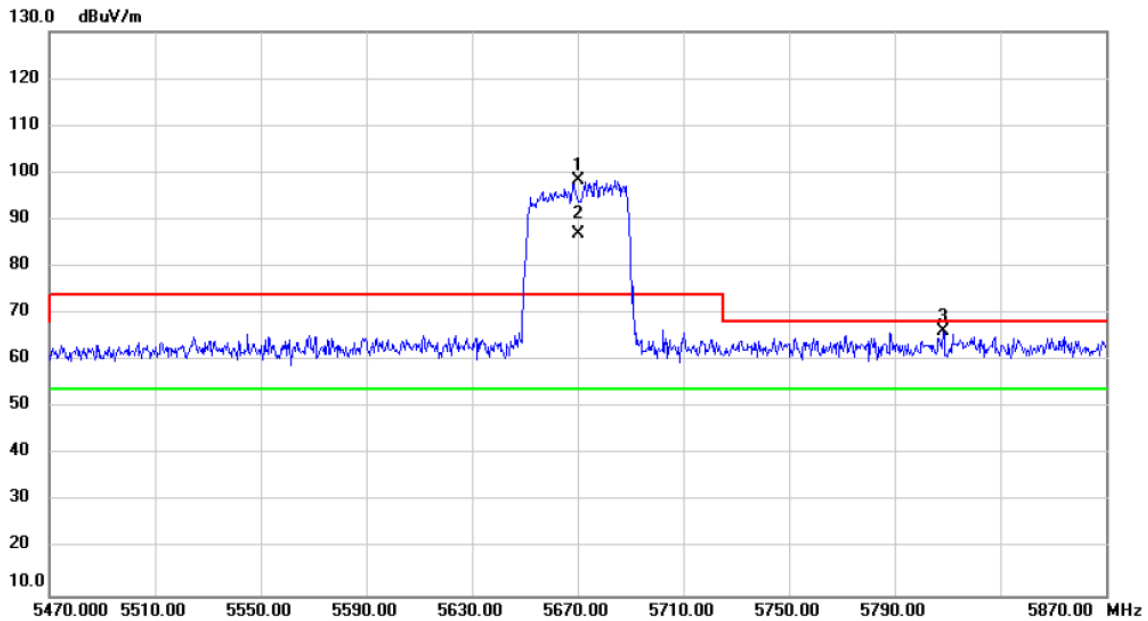

No.	Mk.	Freq.	Reading Level	Correct Factor	Measurement	Limit	Over	Detector	Comment
		MHz	dBuV	dB	dBuV/m	dBuV/m	dB		
1	X	5670.000	60.48	37.97	98.45	74.00	24.45	peak	No Limit
2	*	5670.000	49.08	37.97	87.05	54.00	33.05	AVG	No Limit
3		5808.400	27.89	38.27	66.16	68.20	-2.04	peak	

REMARKS:

- (1) Measurement Value = Reading Level + Correct Factor.
- (2) Margin Level = Measurement Value - Limit Value.

Test Mode	UNII-3_IIEEE 802.11ac (VHT40)	Test Date	2020/7/25
Test Frequency	CH151: 5755 MHz	Polarization	Vertical

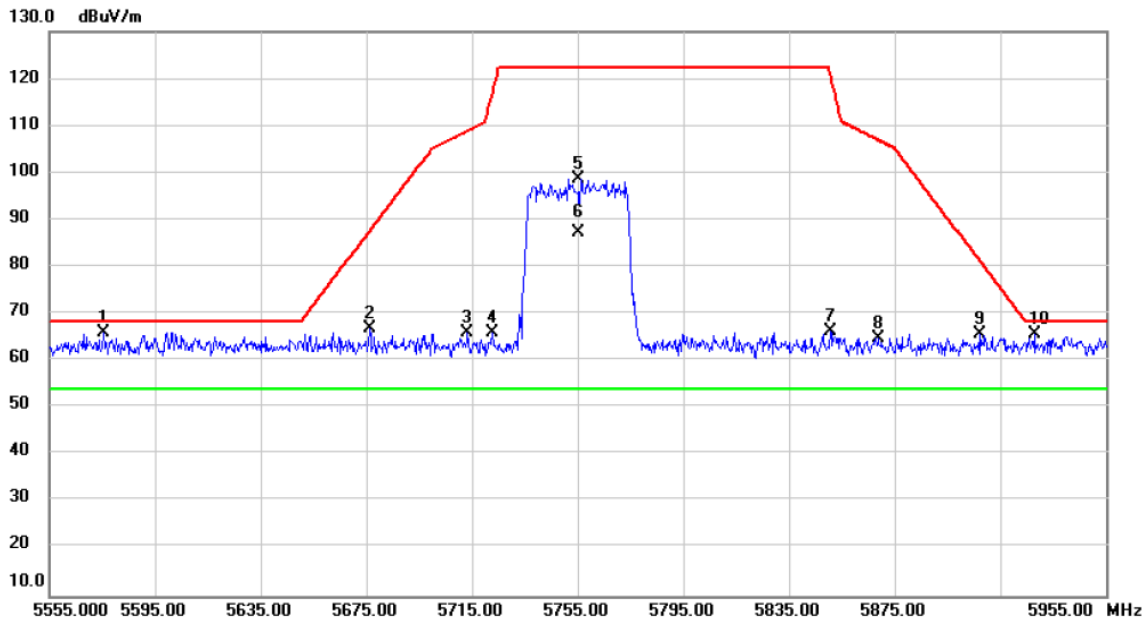

No.	Mk.	Freq. MHz	Reading Level dBuV	Correct Factor dB	Measure- ment dBuV/m	Limit dBuV/m	Over dB	Detector	Comment
1		5575.400	28.21	37.77	65.98	68.20	-2.22	peak	
2		5676.200	28.76	37.99	66.75	87.63	-20.88	peak	
3		5713.400	27.99	38.07	66.06	108.95	-42.89	peak	
4		5722.600	27.73	38.09	65.82	116.73	-50.91	peak	
5		5755.000	60.46	38.16	98.62	122.20	-23.58	peak	No Limit
6	*	5755.000	49.06	38.16	87.22	54.00	33.22	AVG	No Limit
7		5850.600	27.82	38.36	66.18	120.83	-54.65	peak	
8		5868.600	26.47	38.40	64.87	106.99	-42.12	peak	
9		5907.000	27.15	38.48	65.63	81.48	-15.85	peak	
10		5927.800	27.20	38.52	65.72	68.20	-2.48	peak	

REMARKS:

- (1) Measurement Value = Reading Level + Correct Factor.
- (2) Margin Level = Measurement Value - Limit Value.

Test Mode	UNII-3_IEEE 802.11ac (VHT40)	Test Date	2020/7/25
Test Frequency	CH159: 5795 MHz	Polarization	Vertical

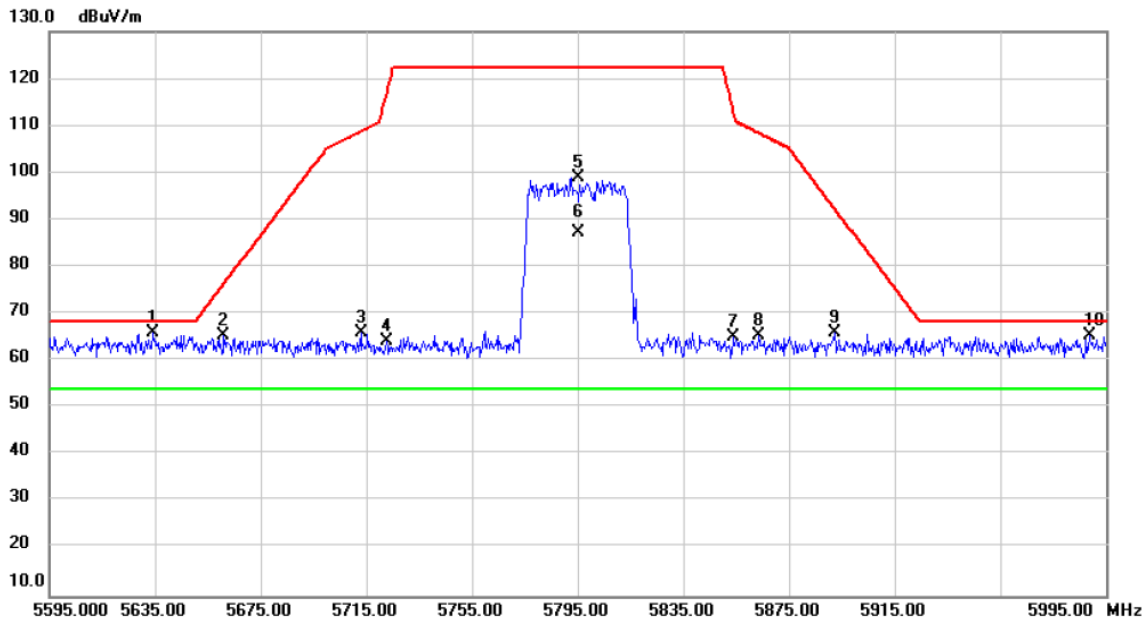

No.	Mk.	Freq.	Reading Level	Correct Factor	Measurement	Limit	Over	Detector	Comment
		MHz	dBuV	dB	dBuV/m	dBuV/m	dB		
1		5634.200	28.05	37.90	65.95	68.20	-2.25	peak	
2		5661.000	27.36	37.95	65.31	76.37	-11.06	peak	
3		5713.000	27.96	38.07	66.03	108.84	-42.81	peak	
4		5722.600	26.00	38.09	64.09	116.73	-52.64	peak	
5		5795.000	60.59	38.24	98.83	122.20	-23.37	peak	No Limit
6	*	5795.000	48.88	38.24	87.12	54.00	33.12	AVG	No Limit
7		5854.200	26.53	38.37	64.90	112.62	-47.72	peak	
8		5863.400	26.82	38.39	65.21	108.45	-43.24	peak	
9		5892.200	27.38	38.45	65.83	92.44	-26.61	peak	
10		5988.600	26.79	38.66	65.45	68.20	-2.75	peak	

REMARKS:

- (1) Measurement Value = Reading Level + Correct Factor.
- (2) Margin Level = Measurement Value - Limit Value.

Test Mode	UNII-1_IEEE 802.11ac (VHT80)	Test Date	2020/7/25
Test Frequency	CH42: 5210 MHz	Polarization	Vertical

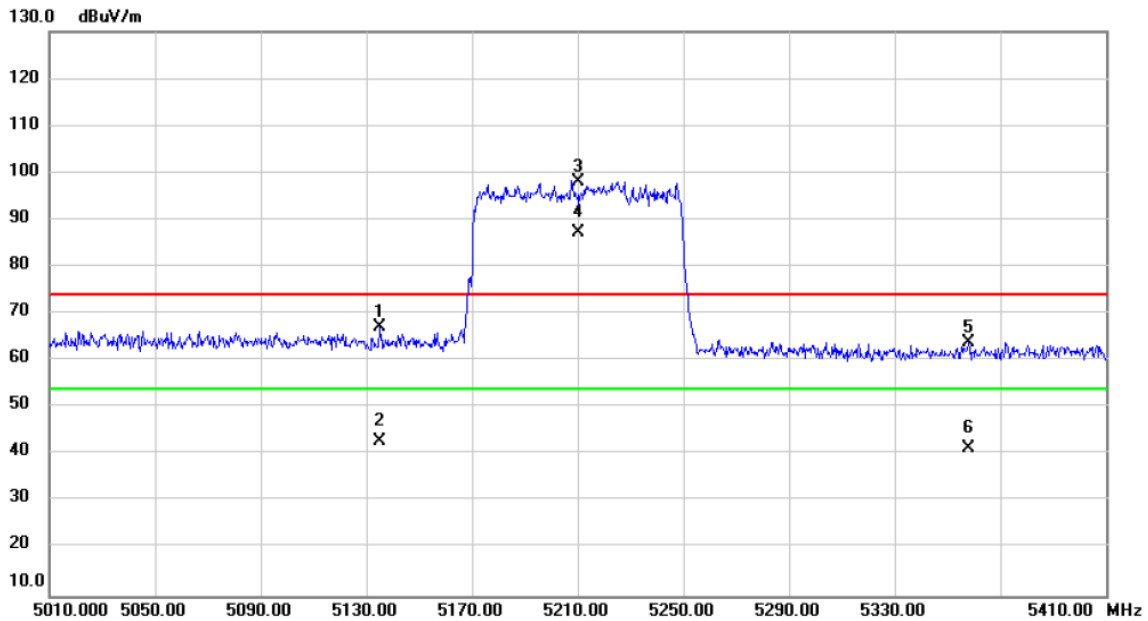

No.	Mk.	Freq. MHz	Reading Level dBuV	Correct Factor dB	Measure- ment dBuV/m	Limit dBuV/m	Over dB	Detector	Comment
1		5135.200	29.81	37.29	67.10	74.00	-6.90	peak	
2		5135.200	5.51	37.29	42.80	54.00	-11.20	AVG	
3	X	5210.000	60.84	37.36	98.20	74.00	24.20	peak	No Limit
4	*	5210.000	49.92	37.36	87.28	54.00	33.28	AVG	No Limit
5		5358.000	26.42	37.48	63.90	74.00	-10.10	peak	
6		5358.000	3.74	37.48	41.22	54.00	-12.78	AVG	

REMARKS:

- (1) Measurement Value = Reading Level + Correct Factor.
- (2) Margin Level = Measurement Value - Limit Value.

Test Mode	UNII-2A_ IEEE 802.11ac (VHT80)	Test Date	2020/7/25
Test Frequency	CH58: 5290 MHz	Polarization	Vertical

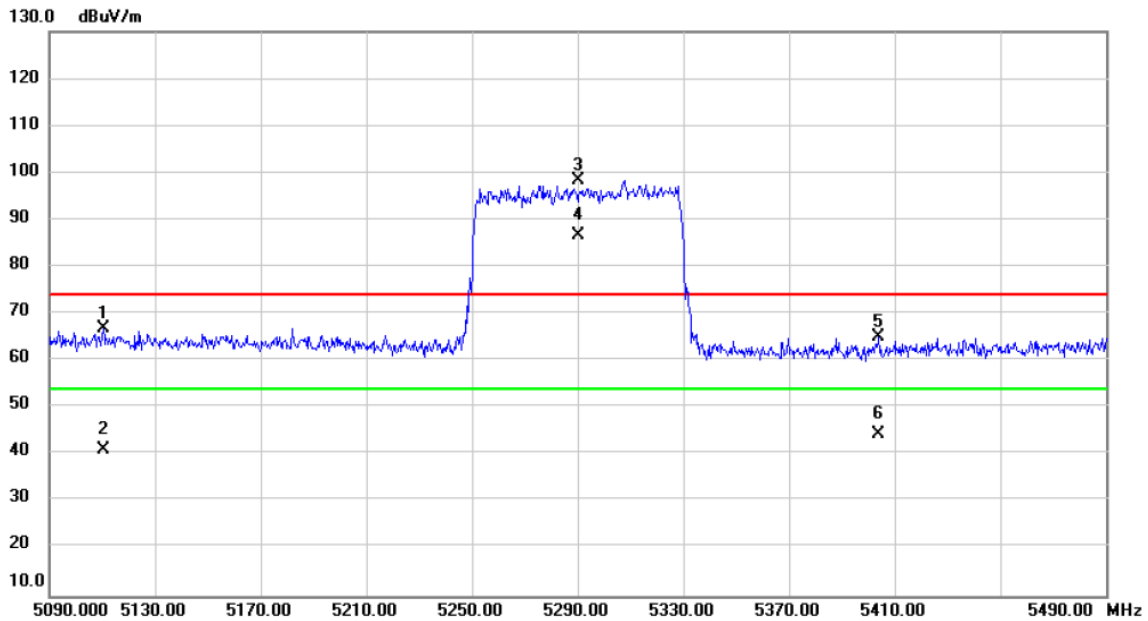

No.	Mk.	Freq.	Reading Level	Correct Factor	Measurement	Limit	Over	Detector	Comment
		MHz	dBuV	dB	dBuV/m	dBuV/m	dB		
1	X	5110.400	29.70	37.27	66.97	74.00	-7.03	peak	
2	X	5110.400	3.91	37.27	41.18	54.00	-12.82	AVG	
3	X	5290.000	60.81	37.42	98.23	74.00	24.23	peak	No Limit
4	*	5290.000	49.30	37.42	86.72	54.00	32.72	AVG	No Limit
5	X	5404.000	27.40	37.52	64.92	74.00	-9.08	peak	
6	X	5404.000	6.93	37.52	44.45	54.00	-9.55	AVG	

REMARKS:

- (1) Measurement Value = Reading Level + Correct Factor.
- (2) Margin Level = Measurement Value - Limit Value.

Test Mode	UNII-2C_IEEE 802.11ac (VHT80)	Test Date	2020/7/25
Test Frequency	CH106: 5530 MHz	Polarization	Vertical

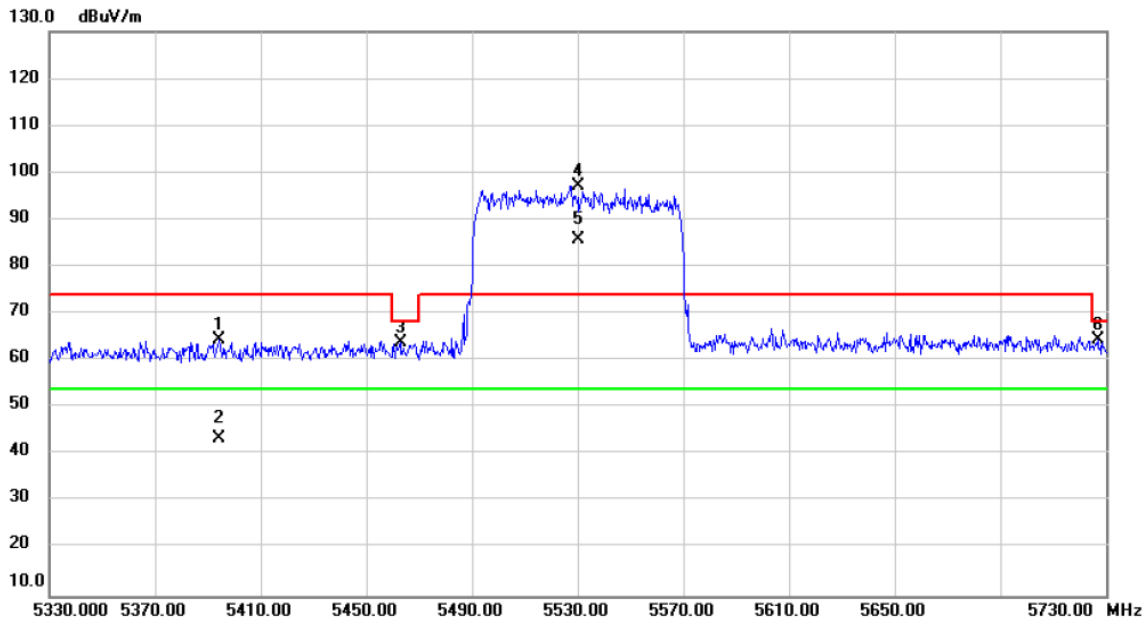

No.	Mk.	Freq.	Reading Level	Correct Factor	Measurement	Limit	Over	Detector	Comment
		MHz	dBuV	dB	dBuV/m	dBuV/m	dB		
1		5394.400	26.80	37.52	64.32	74.00	-9.68	peak	
2		5394.400	5.89	37.52	43.41	54.00	-10.59	AVG	
3		5462.800	26.22	37.58	63.80	68.20	-4.40	peak	
4	X	5530.000	59.58	37.68	97.26	74.00	23.26	peak	No Limit
5	*	5530.000	48.18	37.68	85.86	54.00	31.86	AVG	No Limit
6		5726.800	26.37	38.09	64.46	68.20	-3.74	peak	

REMARKS:

- (1) Measurement Value = Reading Level + Correct Factor.
- (2) Margin Level = Measurement Value - Limit Value.

Test Mode	UNII-2C_IEEE 802.11ac (VHT80)	Test Date	2020/7/25
Test Frequency	CH122: 5610 MHz	Polarization	Vertical

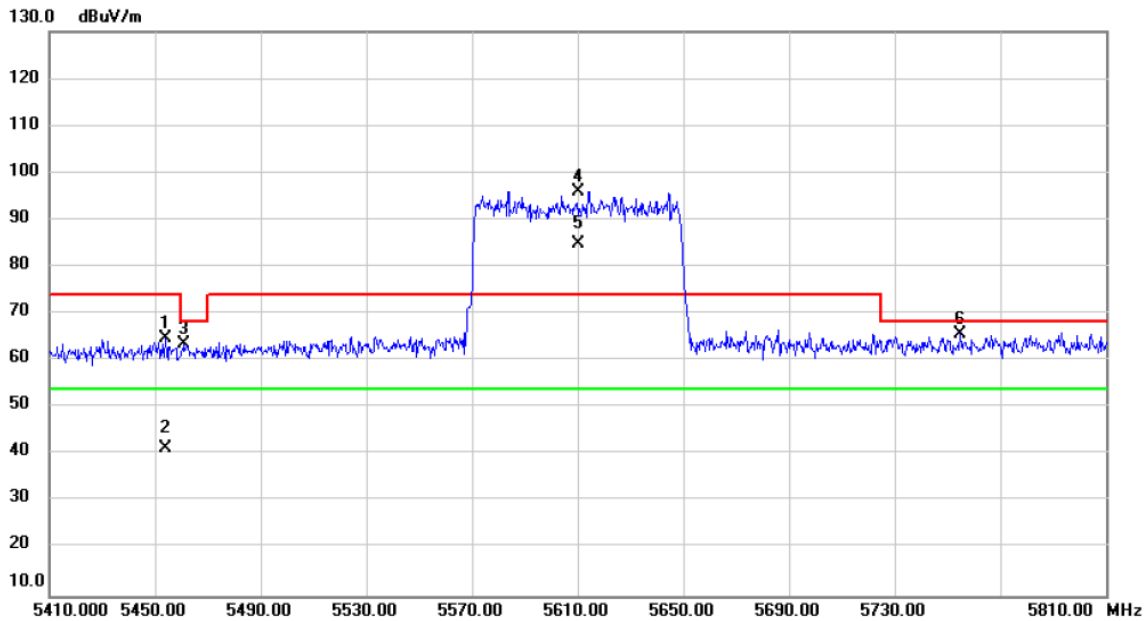

No.	Mk.	Freq.	Reading Level	Correct Factor	Measurement	Limit	Over	Detector	Comment
		MHz	dBuV	dB	dBuV/m	dBuV/m	dB		
1		5454.000	27.12	37.57	64.69	74.00	-9.31	peak	
2		5454.000	3.92	37.57	41.49	54.00	-12.51	AVG	
3		5461.200	25.98	37.58	63.56	68.20	-4.64	peak	
4	X	5610.000	58.26	37.84	96.10	74.00	22.10	peak	No Limit
5	*	5610.000	46.92	37.84	84.76	54.00	30.76	AVG	No Limit
6		5754.800	27.41	38.16	65.57	68.20	-2.63	peak	

REMARKS:

- (1) Measurement Value = Reading Level + Correct Factor.
- (2) Margin Level = Measurement Value - Limit Value.

Test Mode	UNII-3_IIEEE 802.11ac (VHT80)	Test Date	2020/7/25
Test Frequency	CH155: 5775 MHz	Polarization	Vertical

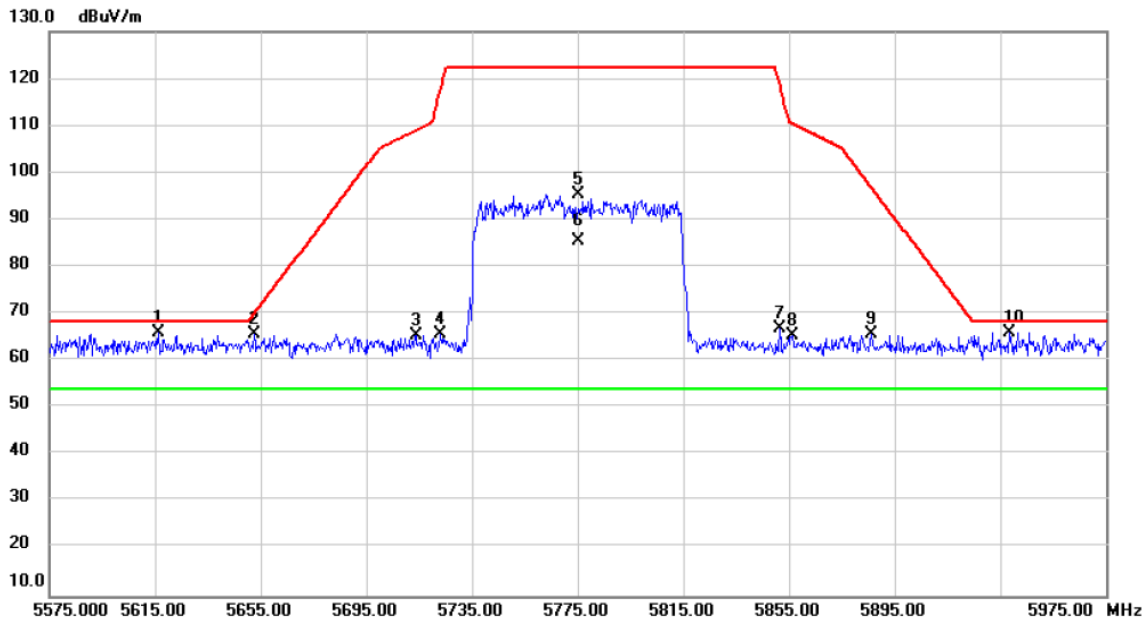

No.	Mk.	Freq. MHz	Reading Level dBuV	Correct Factor dB	Measure- ment dBuV/m	Limit dBuV/m	Over dB	Detector	Comment
1		5616.200	28.07	37.86	65.93	68.20	-2.27	peak	
2		5652.600	27.83	37.93	65.76	70.13	-4.37	peak	
3		5713.800	27.29	38.07	65.36	109.07	-43.71	peak	
4		5723.000	27.60	38.09	65.69	117.64	-51.95	peak	
5		5775.000	57.14	38.20	95.34	122.20	-26.86	peak	No Limit
6	*	5775.000	47.40	38.20	85.60	54.00	31.60	AVG	No Limit
7		5851.400	28.57	38.36	66.93	119.01	-52.08	peak	
8		5856.200	26.85	38.37	65.22	110.46	-45.24	peak	
9		5886.200	27.21	38.43	65.64	96.88	-31.24	peak	
10		5938.600	27.44	38.55	65.99	68.20	-2.21	peak	

REMARKS:

- (1) Measurement Value = Reading Level + Correct Factor.
- (2) Margin Level = Measurement Value - Limit Value.

Test Mode	UNII-1_IEEE 802.11ac (VHT160)	Test Date	2020/7/25
Test Frequency	CH50: 5250 MHz	Polarization	Vertical

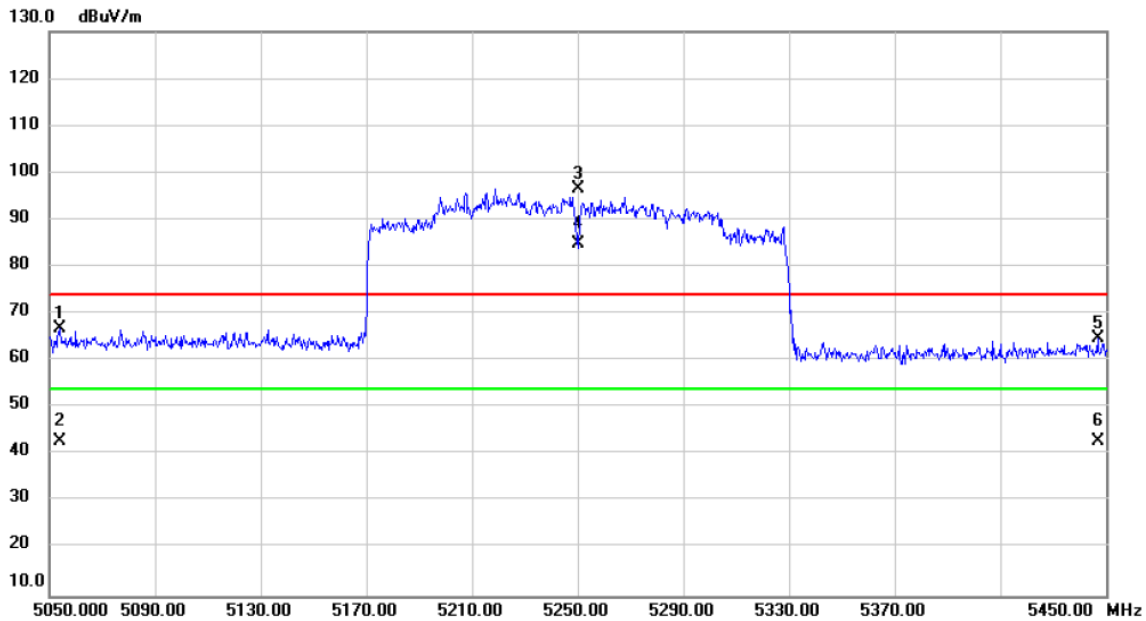

No.	Mk.	Freq.	Reading Level	Correct Factor	Measurement	Limit	Over	Detector	Comment
		MHz	dBuV	dB	dBuV/m	dBuV/m	dB		
1		5054.000	29.58	37.22	66.80	74.00	-7.20	peak	
2		5054.000	5.68	37.22	42.90	54.00	-11.10	AVG	
3	X	5250.000	59.03	37.39	96.42	74.00	22.42	peak	No Limit
4	*	5250.000	47.58	37.39	84.97	54.00	30.97	AVG	No Limit
5		5446.800	27.29	37.57	64.86	74.00	-9.14	peak	
6		5446.800	5.36	37.57	42.93	54.00	-11.07	AVG	

REMARKS:

- (1) Measurement Value = Reading Level + Correct Factor.
- (2) Margin Level = Measurement Value - Limit Value.

Test Mode	UNII-2C_IEEE 802.11ac (VHT160)	Test Date	2020/7/25
Test Frequency	CH114: 5570 MHz	Polarization	Vertical

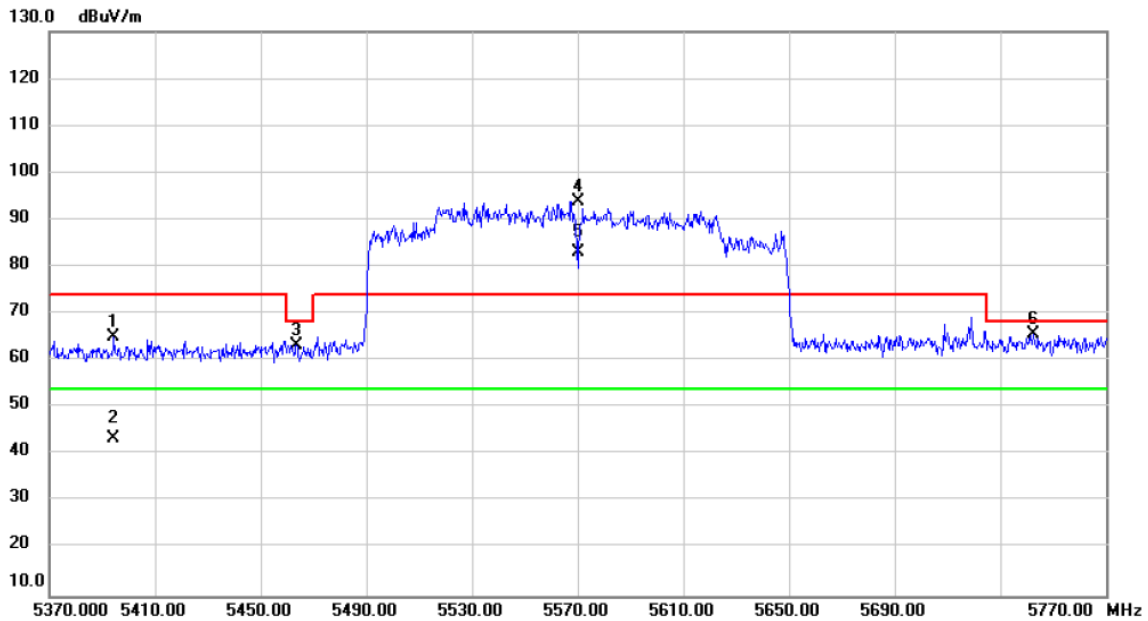

No.	Mk.	Freq.	Reading Level	Correct Factor	Measurement	Limit	Over	Detector	Comment
		MHz	dBuV	dB	dBuV/m	dBuV/m	dB		
1	X	5394.400	27.55	37.52	65.07	74.00	-8.93	peak	
2		5394.400	6.00	37.52	43.52	54.00	-10.48	AVG	
3	X	5463.600	25.81	37.58	63.39	68.20	-4.81	peak	
4	X	5570.000	56.17	37.76	93.93	74.00	19.93	peak	No Limit
5	*	5570.000	45.24	37.76	83.00	54.00	29.00	AVG	No Limit
6	X	5742.400	27.51	38.13	65.64	68.20	-2.56	peak	

REMARKS:

- (1) Measurement Value = Reading Level + Correct Factor.
- (2) Margin Level = Measurement Value - Limit Value.

Test Mode	UNII-1_IEEE 802.11ax (HE20)	Test Date	2020/7/25
Test Frequency	CH36: 5180 MHz	Polarization	Vertical

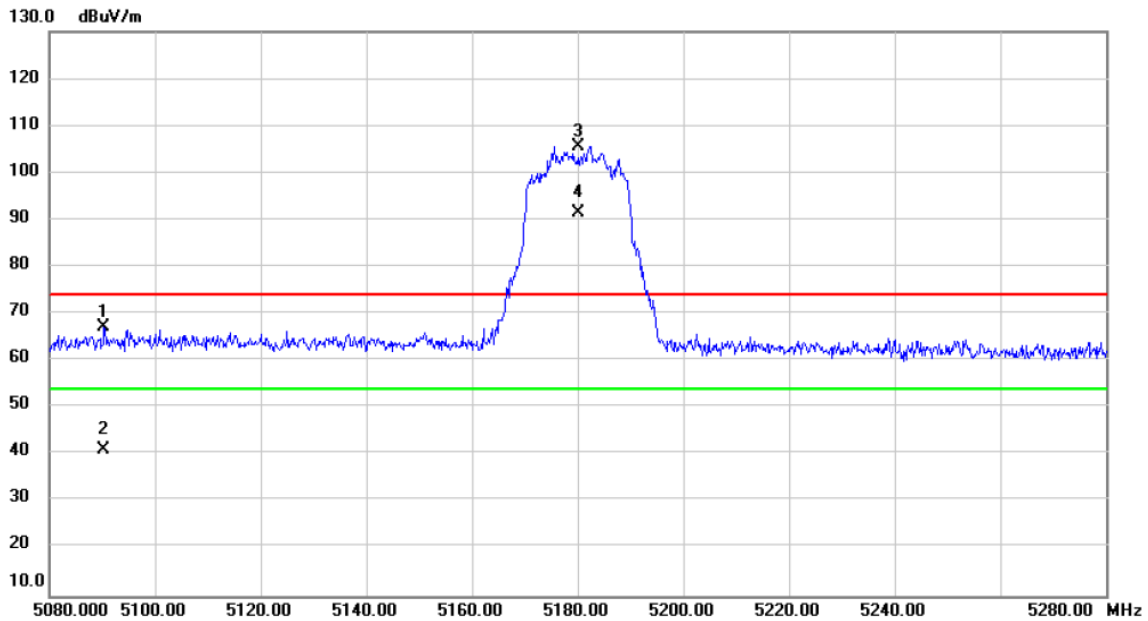

No.	Mk.	Freq.	Reading Level	Correct Factor	Measurement	Limit	Over	Detector	Comment
		MHz	dBuV	dB	dBuV/m	dBuV/m	dB		
1		5090.400	29.84	37.25	67.09	74.00	-6.91	peak	
2		5090.400	3.75	37.25	41.00	54.00	-13.00	AVG	
3	X	5180.000	68.34	37.33	105.67	74.00	31.67	peak	No Limit
4	*	5180.000	54.11	37.33	91.44	54.00	37.44	AVG	No Limit

REMARKS:

- (1) Measurement Value = Reading Level + Correct Factor.
- (2) Margin Level = Measurement Value - Limit Value.

Test Mode	UNII-1_IEEE 802.11ax (HE20)	Test Date	2020/7/25
Test Frequency	CH48: 5240 MHz	Polarization	Vertical

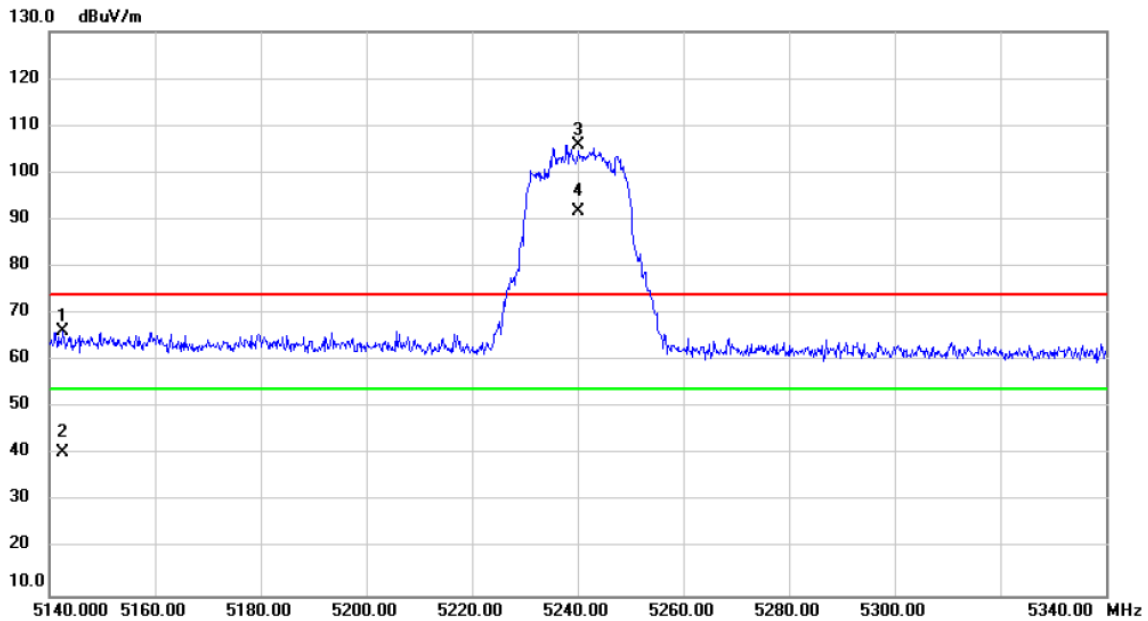

No.	Mk.	Freq.	Reading Level	Correct Factor	Measurement	Limit	Over	Detector	Comment
		MHz	dBuV	dB	dBuV/m	dBuV/m	dB		
1		5142.600	28.81	37.30	66.11	74.00	-7.89	peak	
2		5142.600	3.04	37.30	40.34	54.00	-13.66	AVG	
3	X	5240.000	68.44	37.38	105.82	74.00	31.82	peak	No Limit
4	*	5240.000	54.26	37.38	91.64	54.00	37.64	AVG	No Limit

REMARKS:

- (1) Measurement Value = Reading Level + Correct Factor.
- (2) Margin Level = Measurement Value - Limit Value.

Test Mode	UNII-2A_IEEE 802.11ax (HE20)	Test Date	2020/7/25
Test Frequency	CH52: 5260 MHz	Polarization	Vertical

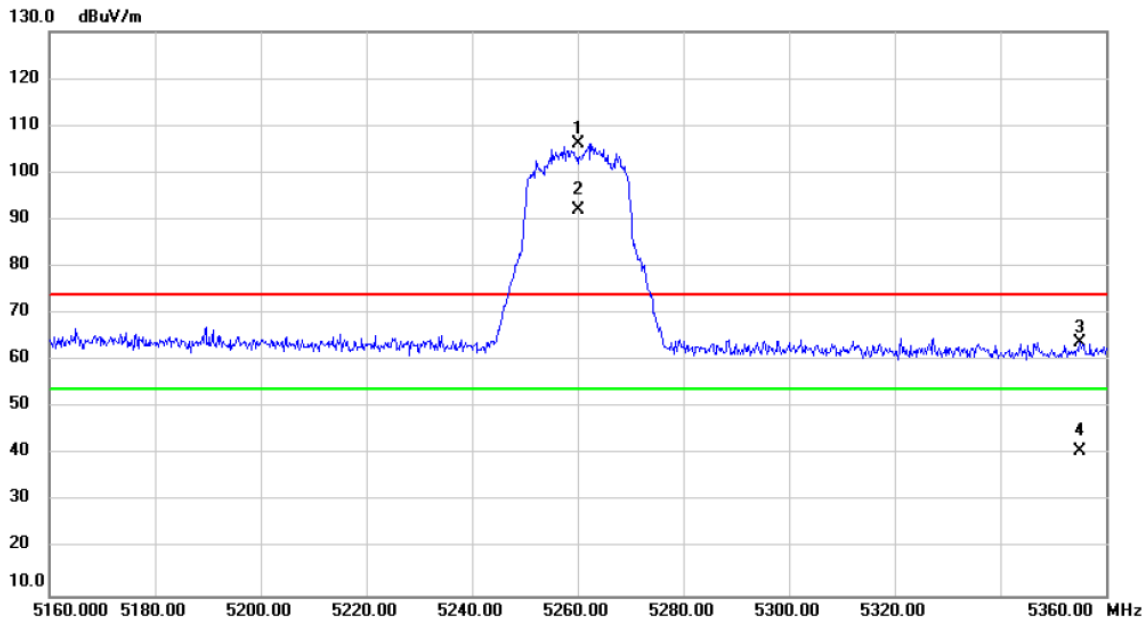

No.	Mk.	Freq.	Reading Level	Correct Factor	Measurement	Limit	Over	Detector	Comment
		MHz	dBuV	dB	dBuV/m	dBuV/m	dB		
1	X	5260.000	68.63	37.40	106.03	74.00	32.03	peak	No Limit
2	*	5260.000	54.61	37.40	92.01	54.00	38.01	AVG	No Limit
3		5355.000	26.44	37.48	63.92	74.00	-10.08	peak	
4		5355.000	3.34	37.48	40.82	54.00	-13.18	AVG	

REMARKS:

- (1) Measurement Value = Reading Level + Correct Factor.
- (2) Margin Level = Measurement Value - Limit Value.

Test Mode	UNII-2A_IEEE 802.11ax (HE20)	Test Date	2020/7/25
Test Frequency	CH64: 5320 MHz	Polarization	Vertical

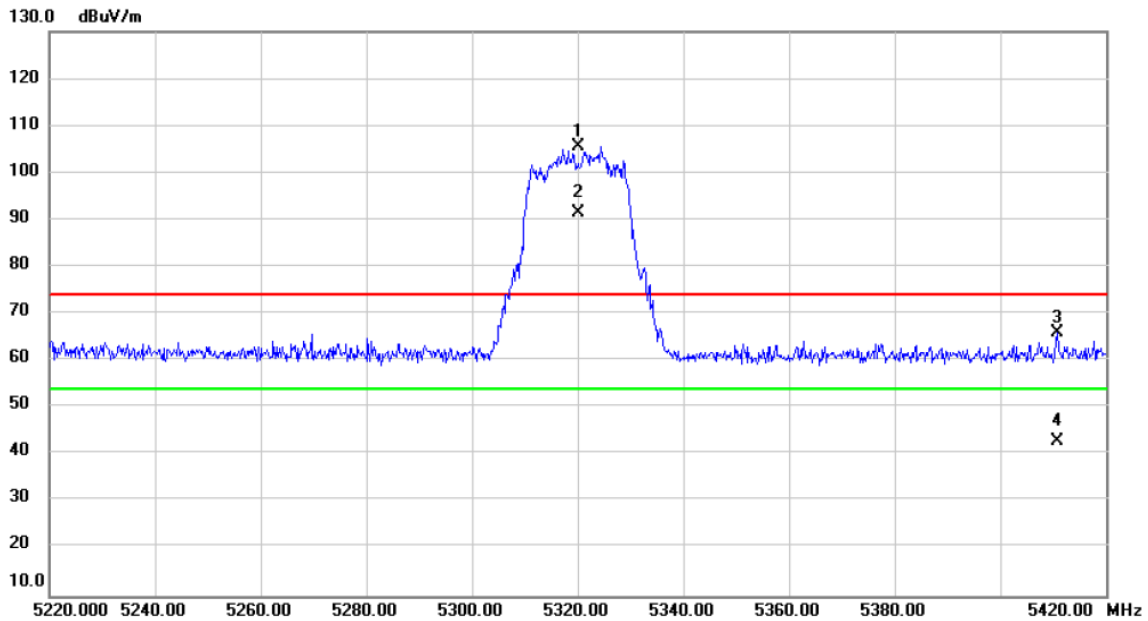

No.	Mk.	Freq.	Reading Level	Correct Factor	Measurement	Limit	Over	Detector	Comment
		MHz	dBuV	dB	dBuV/m	dBuV/m	dB		
1	X	5320.000	67.95	37.45	105.40	74.00	31.40	peak	No Limit
2	*	5320.000	54.13	37.45	91.58	54.00	37.58	AVG	No Limit
3		5410.800	28.37	37.54	65.91	74.00	-8.09	peak	
4		5410.800	5.22	37.54	42.76	54.00	-11.24	AVG	

REMARKS:

- (1) Measurement Value = Reading Level + Correct Factor.
- (2) Margin Level = Measurement Value - Limit Value.

Test Mode	UNII-2C_IEEE 802.11ax (HE20)	Test Date	2020/7/25
Test Frequency	CH100: 5500 MHz	Polarization	Vertical

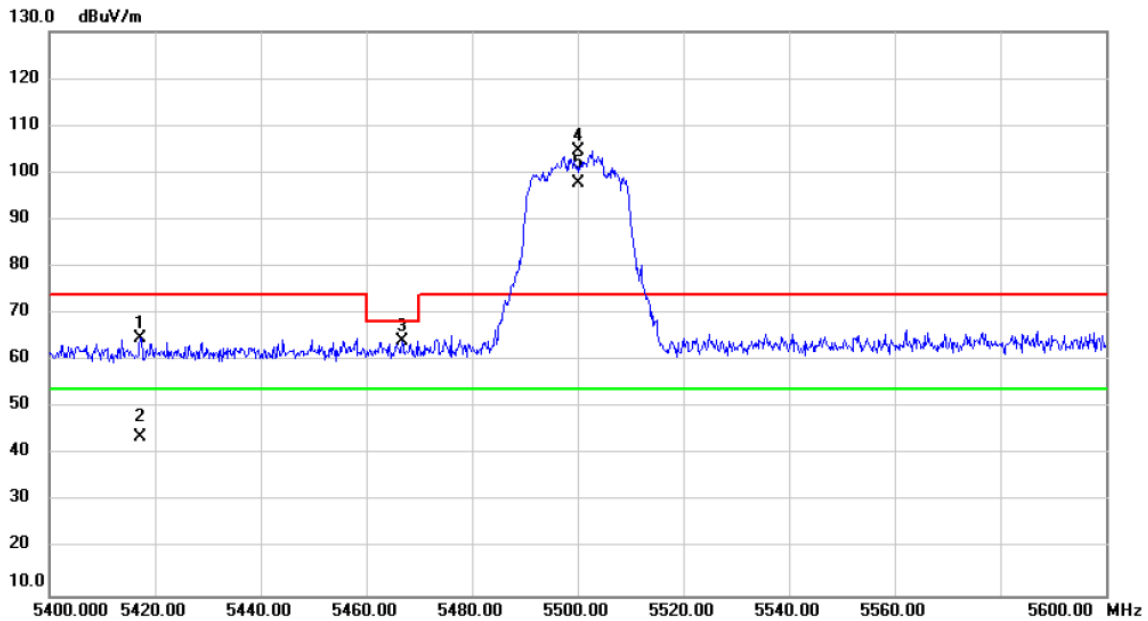

No.	Mk.	Freq.	Reading Level	Correct Factor	Measurement	Limit	Over	Detector	Comment
		MHz	dBuV	dB	dBuV/m	dBuV/m	dB		
1		5417.200	27.14	37.54	64.68	74.00	-9.32	peak	
2		5417.200	6.09	37.54	43.63	54.00	-10.37	AVG	
3		5466.800	26.48	37.58	64.06	68.20	-4.14	peak	
4	X	5500.000	66.93	37.61	104.54	74.00	30.54	peak	No Limit
5	*	5500.000	60.00	37.61	97.61	54.00	43.61	AVG	No Limit

REMARKS:

- (1) Measurement Value = Reading Level + Correct Factor.
- (2) Margin Level = Measurement Value - Limit Value.

Test Mode	UNII-2C_IEEE 802.11ax (HE20)	Test Date	2020/7/25
Test Frequency	CH140: 5700 MHz	Polarization	Vertical

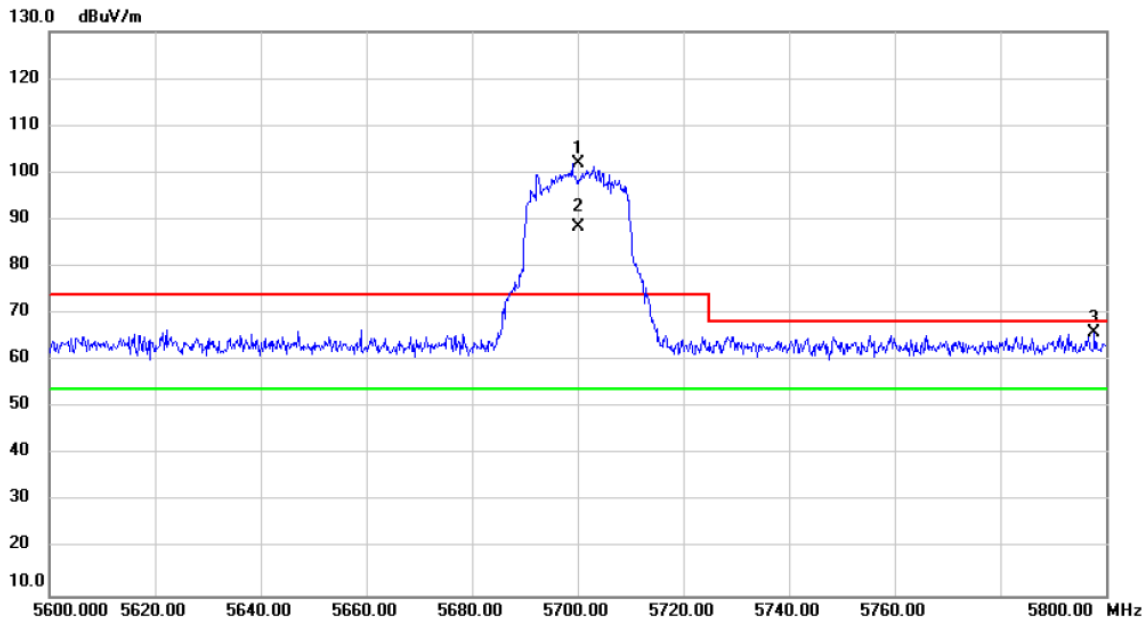

No.	Mk.	Freq.	Reading Level	Correct Factor	Measurement	Limit	Over	Detector	Comment
		MHz	dBuV	dB	dBuV/m	dBuV/m	dB		
1	X	5700.000	63.88	38.04	101.92	74.00	27.92	peak	No Limit
2	*	5700.000	50.43	38.04	88.47	54.00	34.47	AVG	No Limit
3		5797.800	27.64	38.25	65.89	68.20	-2.31	peak	

REMARKS:

- (1) Measurement Value = Reading Level + Correct Factor.
- (2) Margin Level = Measurement Value - Limit Value.

Test Mode	UNII-3_IEEE 802.11ax (HE20)	Test Date	2020/7/25
Test Frequency	CH149: 5745 MHz	Polarization	Vertical

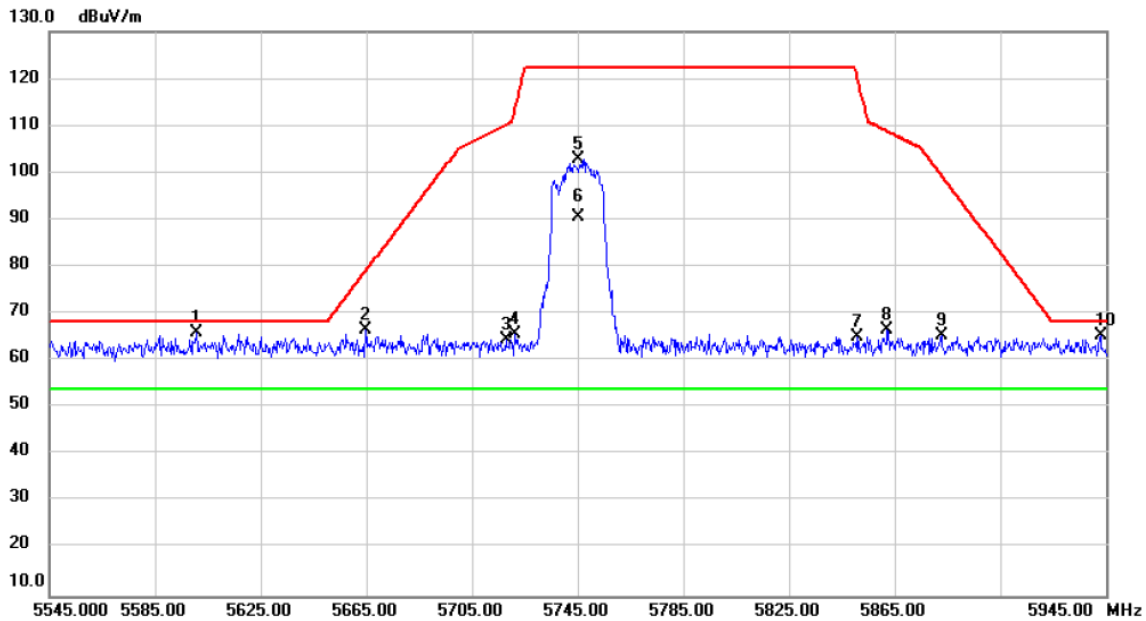

No. Mk.	Freq. MHz	Reading Level dBuV	Correct Factor dB	Measurement dBuV/m	Limit dBuV/m	Over dB	Detector	Comment
1	5600.600	28.12	37.82	65.94	68.20	-2.26	peak	
2	5664.600	28.49	37.96	66.45	79.04	-12.59	peak	
3	5717.800	26.30	38.07	64.37	110.18	-45.81	peak	
4	5721.400	27.63	38.09	65.72	113.99	-48.27	peak	
5	5745.000	64.75	38.13	102.88	122.20	-19.32	peak	No Limit
6 *	5745.000	52.43	38.13	90.56	54.00	36.56	AVG	No Limit
7	5851.000	26.72	38.36	65.08	119.92	-54.84	peak	
8	5862.200	28.14	38.38	66.52	108.78	-42.26	peak	
9	5882.600	26.88	38.43	65.31	99.56	-34.25	peak	
10	5943.000	26.76	38.56	65.32	68.20	-2.88	peak	

REMARKS:

- (1) Measurement Value = Reading Level + Correct Factor.
- (2) Margin Level = Measurement Value - Limit Value.

Test Mode	UNII-3_IEEE 802.11ax (HE20)	Test Date	2020/7/25
Test Frequency	CH165: 5825 MHz	Polarization	Vertical

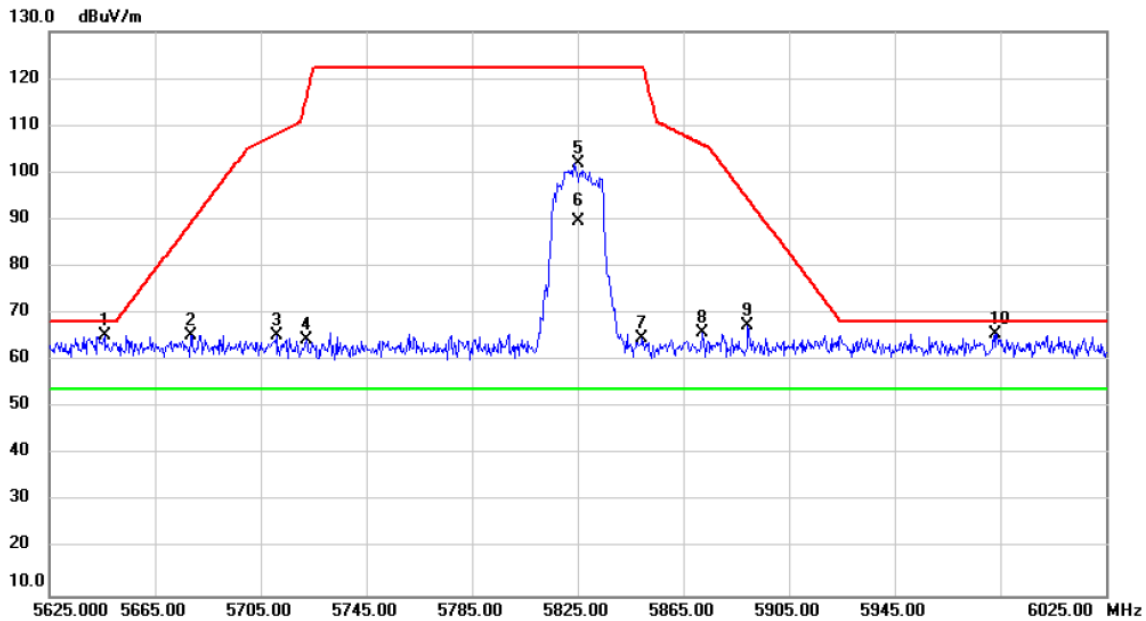

No.	Mk.	Freq. MHz	Reading Level dBuV	Correct Factor dB	Measure- ment dBuV/m	Limit dBuV/m	Over dB	Detector	Comment
1		5645.800	27.28	37.92	65.20	68.20	-3.00	peak	
2		5678.600	27.49	37.99	65.48	89.40	-23.92	peak	
3		5711.000	27.14	38.06	65.20	108.28	-43.08	peak	
4		5722.200	26.39	38.09	64.48	115.82	-51.34	peak	
5		5825.000	63.51	38.31	101.82	122.20	-20.38	peak	No Limit
6	*	5825.000	51.39	38.31	89.70	54.00	35.70	AVG	No Limit
7		5849.400	26.35	38.36	64.71	122.20	-57.49	peak	
8		5872.200	27.51	38.41	65.92	105.98	-40.06	peak	
9		5889.400	28.99	38.45	67.44	94.51	-27.07	peak	
10		5983.400	27.11	38.64	65.75	68.20	-2.45	peak	

REMARKS:

- (1) Measurement Value = Reading Level + Correct Factor.
- (2) Margin Level = Measurement Value - Limit Value.

Test Mode	UNII-1_IEEE 802.11ax (HE40)	Test Date	2020/7/25
Test Frequency	CH38: 5190 MHz	Polarization	Vertical

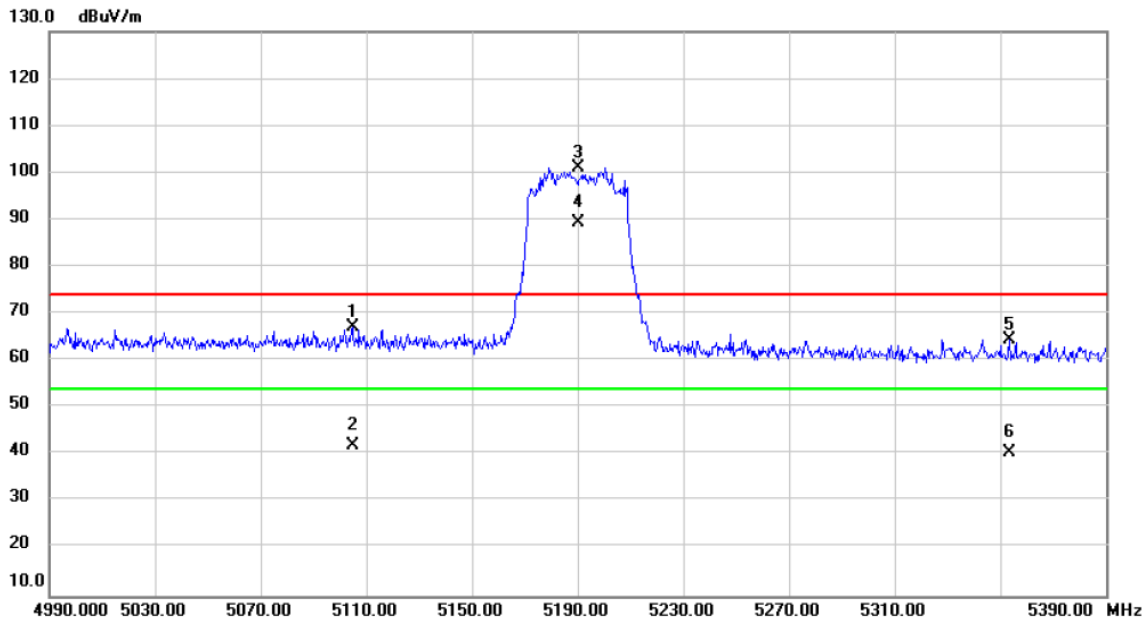

No.	Mk.	Freq.	Reading Level	Correct Factor	Measurement	Limit	Over	Detector	Comment
		MHz	dBuV	dB	dBuV/m	dBuV/m	dB		
1		5104.800	29.75	37.26	67.01	74.00	-6.99	peak	
2		5104.800	4.58	37.26	41.84	54.00	-12.16	AVG	
3	X	5190.000	63.80	37.33	101.13	74.00	27.13	peak	No Limit
4	*	5190.000	52.01	37.33	89.34	54.00	35.34	AVG	No Limit
5		5353.600	27.03	37.48	64.51	74.00	-9.49	peak	
6		5353.600	2.94	37.48	40.42	54.00	-13.58	AVG	

REMARKS:

- (1) Measurement Value = Reading Level + Correct Factor.
- (2) Margin Level = Measurement Value - Limit Value.

Test Mode	UNII-1_IEEE 802.11ax (HE40)	Test Date	2020/7/25
Test Frequency	CH46: 5230 MHz	Polarization	Vertical

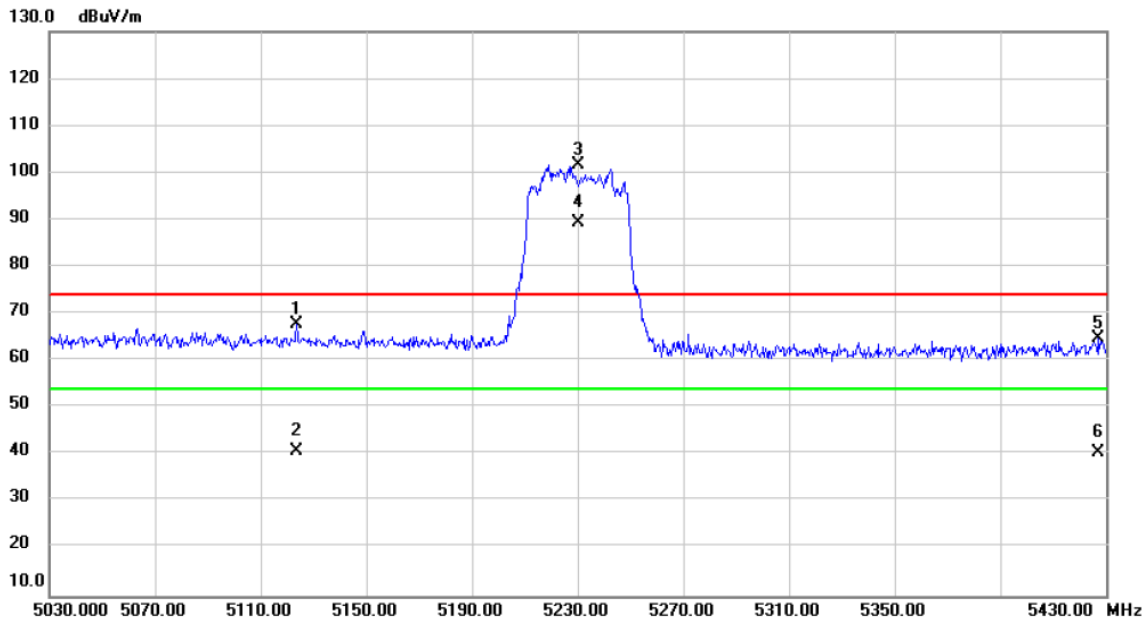

No.	Mk.	Freq.	Reading Level	Correct Factor	Measurement	Limit	Over	Detector	Comment
		MHz	dBuV	dB	dBuV/m	dBuV/m	dB		
1		5123.600	30.34	37.27	67.61	74.00	-6.39	peak	
2		5123.600	3.54	37.27	40.81	54.00	-13.19	AVG	
3	X	5230.000	64.29	37.37	101.66	74.00	27.66	peak	No Limit
4	*	5230.000	51.93	37.37	89.30	54.00	35.30	AVG	No Limit
5		5427.200	27.15	37.55	64.70	74.00	-9.30	peak	
6		5427.200	3.02	37.55	40.57	54.00	-13.43	AVG	

REMARKS:

- (1) Measurement Value = Reading Level + Correct Factor.
- (2) Margin Level = Measurement Value - Limit Value.

Test Mode	UNII-2A_ IEEE 802.11ax (HE40)	Test Date	2020/7/25
Test Frequency	CH54: 5270 MHz	Polarization	Vertical

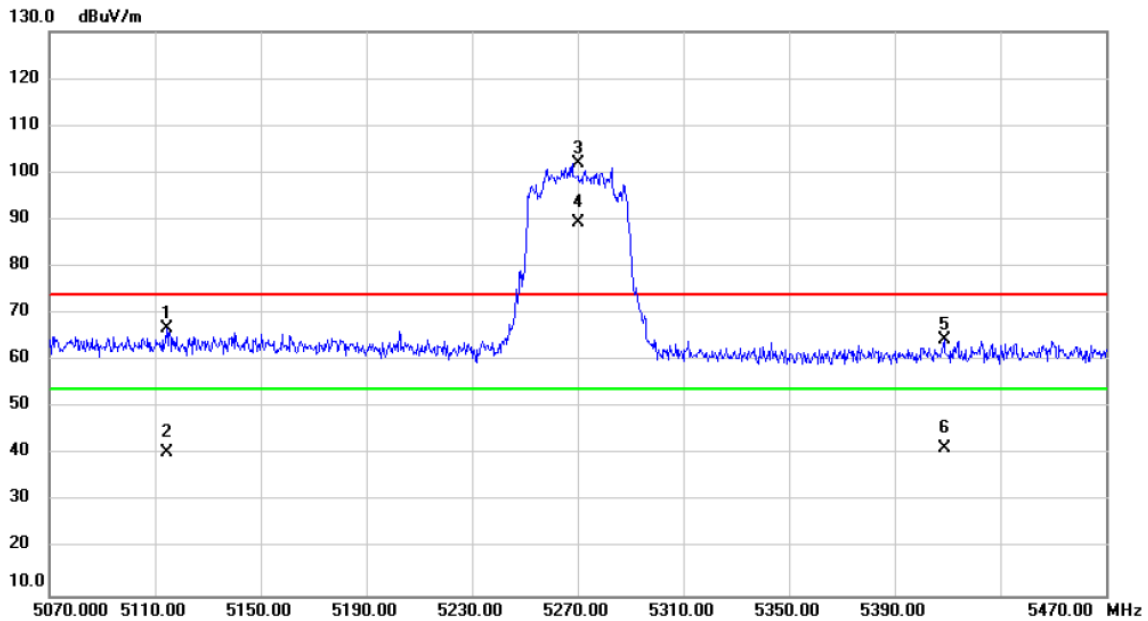

No.	Mk.	Freq.	Reading Level	Correct Factor	Measurement	Limit	Over	Detector	Comment
		MHz	dBuV	dB	dBuV/m	dBuV/m	dB		
1		5114.400	29.70	37.27	66.97	74.00	-7.03	peak	
2		5114.400	3.18	37.27	40.45	54.00	-13.55	AVG	
3	X	5270.000	64.44	37.41	101.85	74.00	27.85	peak	No Limit
4	*	5270.000	52.09	37.41	89.50	54.00	35.50	AVG	No Limit
5		5408.800	26.79	37.53	64.32	74.00	-9.68	peak	
6		5408.800	3.68	37.53	41.21	54.00	-12.79	AVG	

REMARKS:

- (1) Measurement Value = Reading Level + Correct Factor.
- (2) Margin Level = Measurement Value - Limit Value.

Test Mode	UNII-2A_ IEEE 802.11ax (HE40)	Test Date	2020/7/25
Test Frequency	CH62: 5310 MHz	Polarization	Vertical

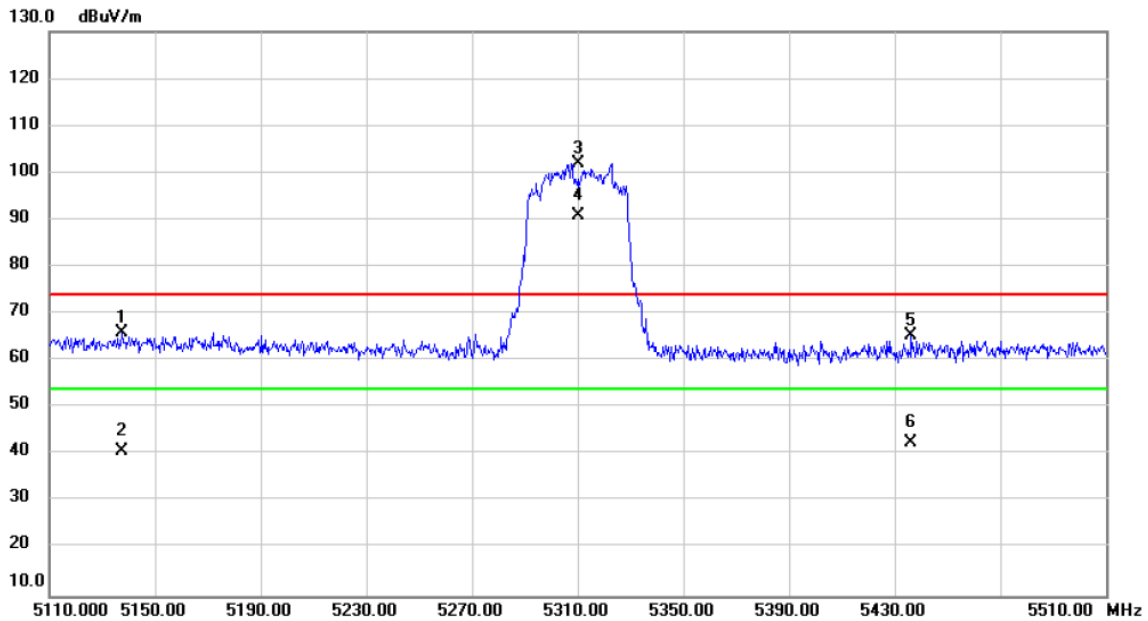

No.	Mk.	Freq. MHz	Reading Level dBuV	Correct Factor dB	Measure- ment dBuV/m	Limit dBuV/m	Over dB	Detector	Comment
1		5137.600	28.60	37.29	65.89	74.00	-8.11	peak	
2		5137.600	3.44	37.29	40.73	54.00	-13.27	AVG	
3	X	5310.000	64.50	37.45	101.95	74.00	27.95	peak	No Limit
4	*	5310.000	53.44	37.45	90.89	54.00	36.89	AVG	No Limit
5		5436.400	27.70	37.55	65.25	74.00	-8.75	peak	
6		5436.400	5.09	37.55	42.64	54.00	-11.36	AVG	

REMARKS:

- (1) Measurement Value = Reading Level + Correct Factor.
- (2) Margin Level = Measurement Value - Limit Value.

Test Mode	UNII-2C_IEEE 802.11ax (HE40)	Test Date	2020/7/25
Test Frequency	CH102: 5510 MHz	Polarization	Vertical

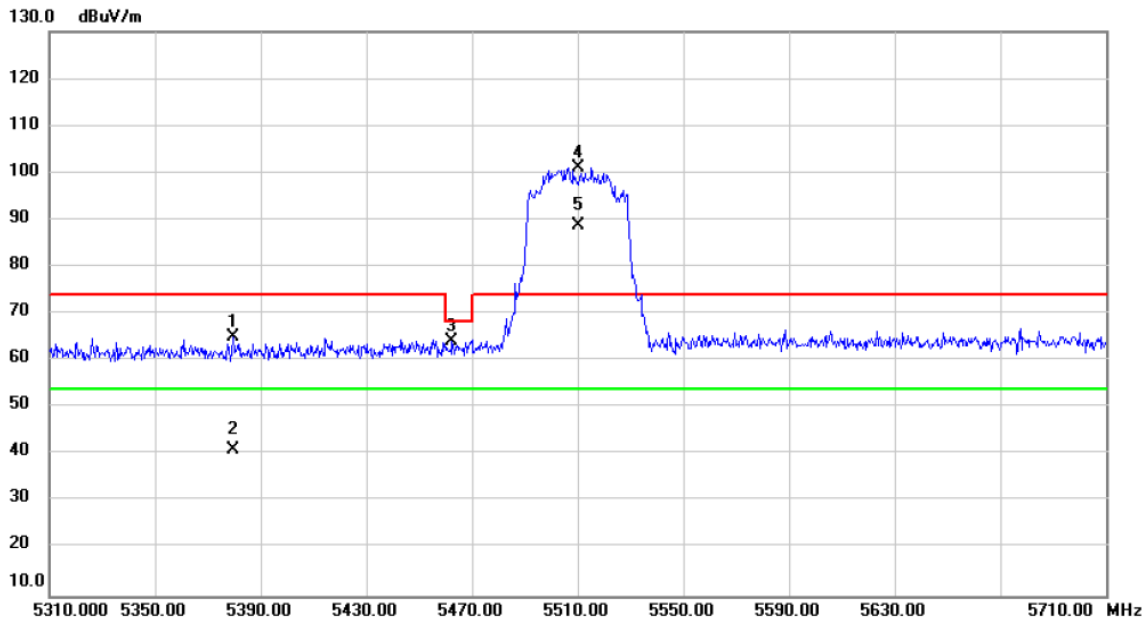

No.	Mk.	Freq.	Reading Level	Correct Factor	Measurement	Limit	Over	Detector	Comment
		MHz	dBuV	dB	dBuV/m	dBuV/m	dB		
1		5379.600	27.52	37.51	65.03	74.00	-8.97	peak	
2		5379.600	3.59	37.51	41.10	54.00	-12.90	AVG	
3		5462.400	26.48	37.58	64.06	68.20	-4.14	peak	
4	X	5510.000	63.50	37.63	101.13	74.00	27.13	peak	No Limit
5	*	5510.000	50.98	37.63	88.61	54.00	34.61	AVG	No Limit

REMARKS:

- (1) Measurement Value = Reading Level + Correct Factor.
- (2) Margin Level = Measurement Value - Limit Value.

Test Mode	UNII-2C_IEEE 802.11ax (HE40)	Test Date	2020/7/25
Test Frequency	CH134: 5670 MHz	Polarization	Vertical

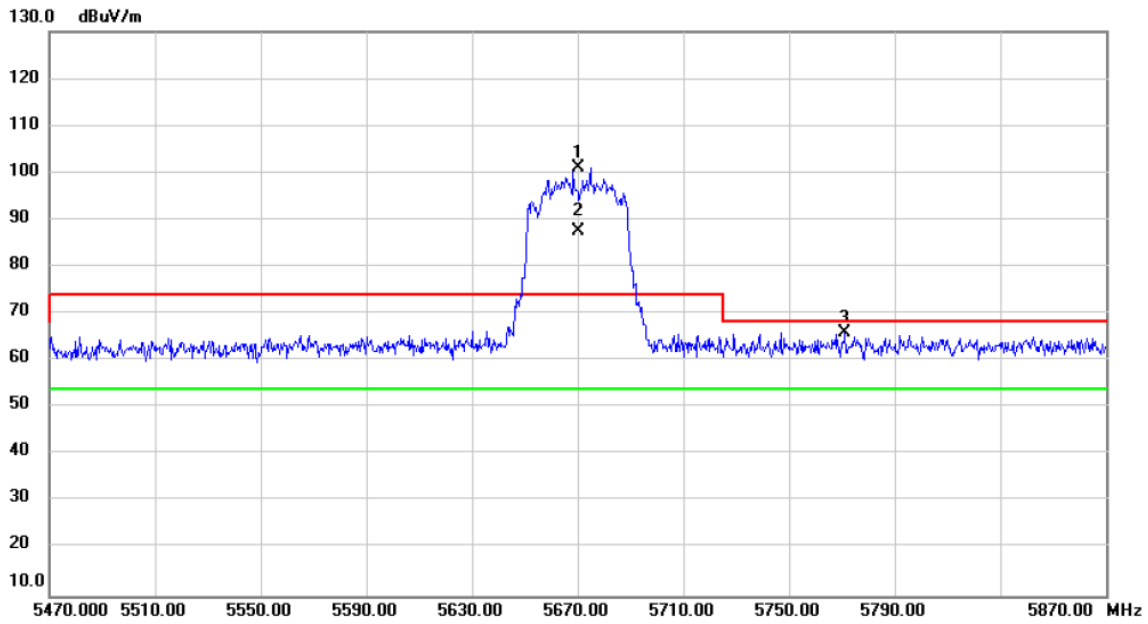

No.	Mk.	Freq.	Reading Level	Correct Factor	Measurement	Limit	Over	Detector	Comment
		MHz	dBuV	dB	dBuV/m	dBuV/m	dB		
1	X	5670.000	63.20	37.97	101.17	74.00	27.17	peak	No Limit
2	*	5670.000	49.62	37.97	87.59	54.00	33.59	AVG	No Limit
3		5771.200	27.79	38.19	65.98	68.20	-2.22	peak	

REMARKS:

- (1) Measurement Value = Reading Level + Correct Factor.
- (2) Margin Level = Measurement Value - Limit Value.

Test Mode	UNII-3_IEEE 802.11ax (HE40)	Test Date	2020/7/25
Test Frequency	CH151: 5755 MHz	Polarization	Vertical

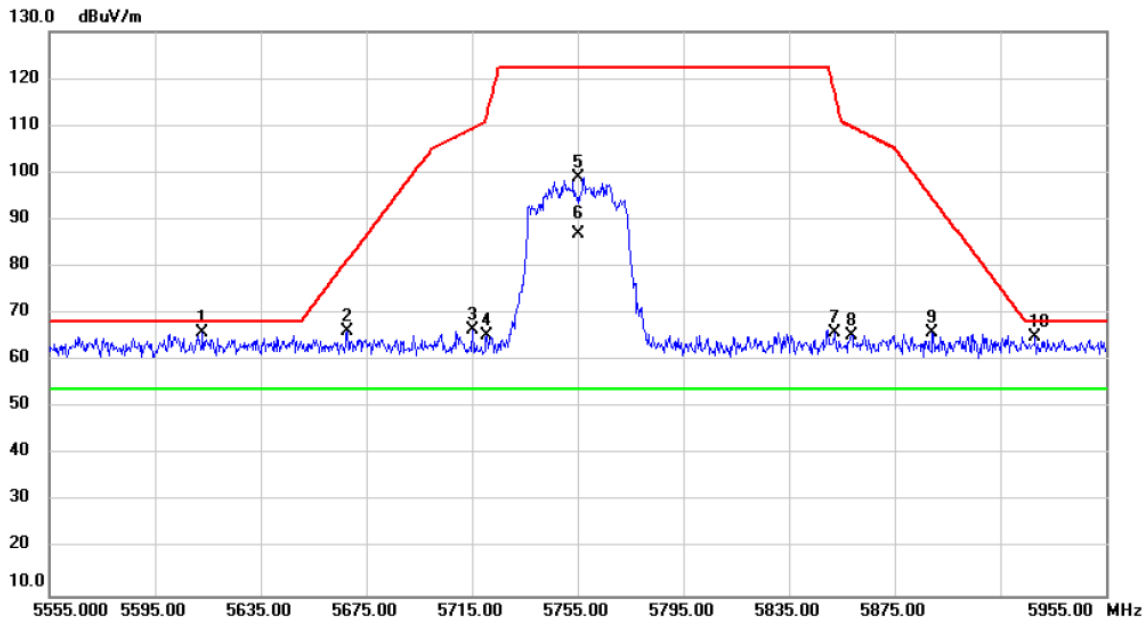

No. Mk.	Freq. MHz	Reading Level dBuV	Correct Factor dB	Measurement dBuV/m	Limit dBuV/m	Over dB	Detector	Comment
1	5613.000	28.00	37.86	65.86	68.20	-2.34	peak	
2	5667.800	28.14	37.97	66.11	81.41	-15.30	peak	
3	5715.000	28.37	38.07	66.44	109.40	-42.96	peak	
4	5720.600	27.29	38.08	65.37	112.17	-46.80	peak	
5	5755.000	60.80	38.16	98.96	122.20	-23.24	peak	No Limit
6 *	5755.000	48.82	38.16	86.98	54.00	32.98	AVG	No Limit
7	5852.200	27.74	38.36	66.10	117.18	-51.08	peak	
8	5858.600	27.09	38.38	65.47	109.79	-44.32	peak	
9	5889.400	27.53	38.45	65.98	94.51	-28.53	peak	
10	5928.200	26.60	38.52	65.12	68.20	-3.08	peak	

REMARKS:

- (1) Measurement Value = Reading Level + Correct Factor.
- (2) Margin Level = Measurement Value - Limit Value.

Test Mode	UNII-3_ IEEE 802.11ax (HE40)	Test Date	2020/7/25
Test Frequency	CH159: 5795 MHz	Polarization	Vertical

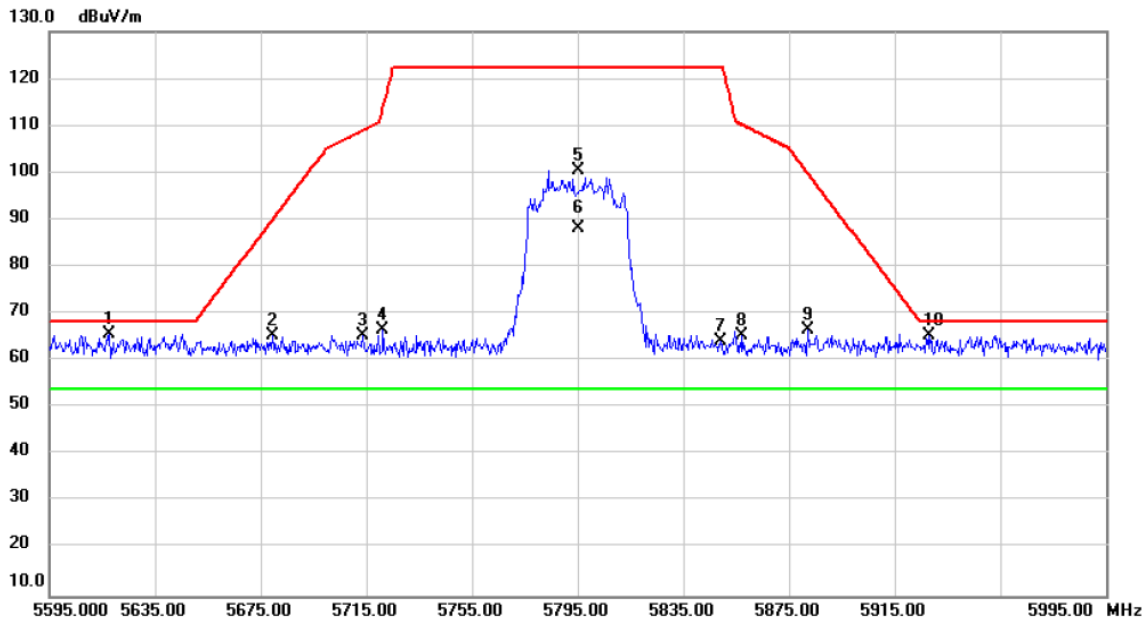

No.	Mk.	Freq.	Reading Level	Correct Factor	Measurement	Limit	Over	Detector	Comment
		MHz	dBuV	dB	dBuV/m	dBuV/m	dB		
1		5617.800	27.78	37.86	65.64	68.20	-2.56	peak	
2		5679.400	27.39	38.00	65.39	90.00	-24.61	peak	
3		5713.800	27.25	38.07	65.32	109.07	-43.75	peak	
4		5721.400	28.45	38.09	66.54	113.99	-47.45	peak	
5		5795.000	62.22	38.24	100.46	122.20	-21.74	peak	No Limit
6	*	5795.000	49.78	38.24	88.02	54.00	34.02	AVG	No Limit
7		5849.400	25.89	38.36	64.25	122.20	-57.95	peak	
8		5857.400	27.11	38.38	65.49	110.13	-44.64	peak	
9		5882.200	28.11	38.43	66.54	99.85	-33.31	peak	
10		5928.200	26.95	38.52	65.47	68.20	-2.73	peak	

REMARKS:

- (1) Measurement Value = Reading Level + Correct Factor.
- (2) Margin Level = Measurement Value - Limit Value.

Test Mode	UNII-1_IEEE 802.11ax (HE80)	Test Date	2020/7/25
Test Frequency	CH42: 5210 MHz	Polarization	Vertical

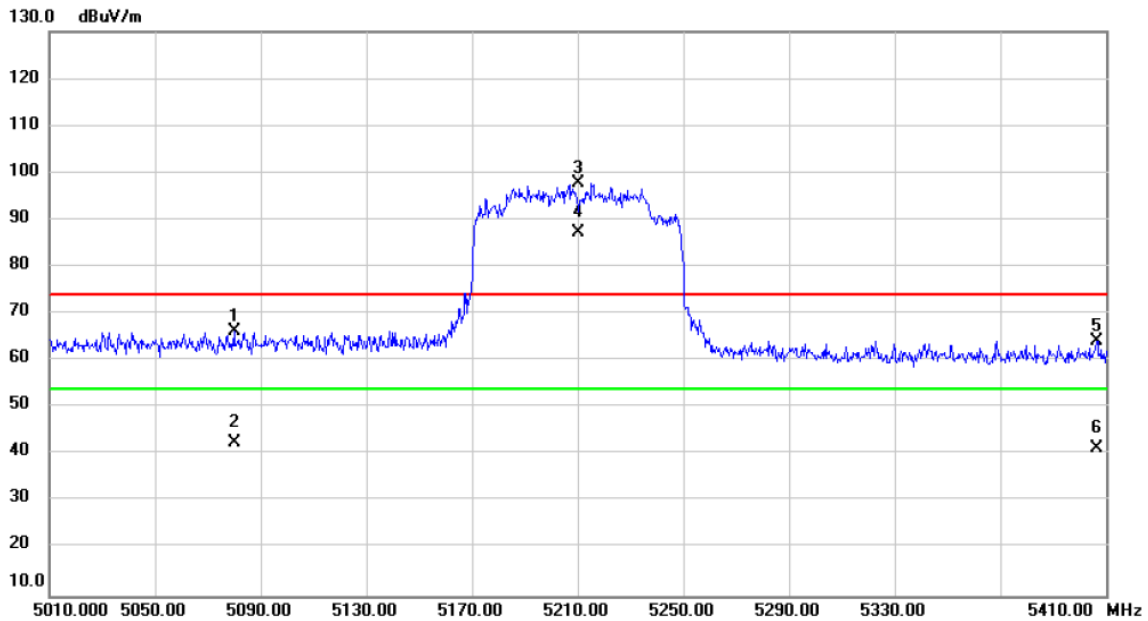

No.	Mk.	Freq.	Reading Level	Correct Factor	Measurement	Limit	Over	Detector	Comment
		MHz	dBuV	dB	dBuV/m	dBuV/m	dB		
1		5080.000	29.06	37.24	66.30	74.00	-7.70	peak	
2		5080.000	5.36	37.24	42.60	54.00	-11.40	AVG	
3	X	5210.000	60.28	37.36	97.64	74.00	23.64	peak	No Limit
4	*	5210.000	49.86	37.36	87.22	54.00	33.22	AVG	No Limit
5		5406.400	26.74	37.52	64.26	74.00	-9.74	peak	
6		5406.400	3.84	37.52	41.36	54.00	-12.64	AVG	

REMARKS:

- (1) Measurement Value = Reading Level + Correct Factor.
- (2) Margin Level = Measurement Value - Limit Value.

Test Mode	UNII-2A_ IEEE 802.11ax (HE80)	Test Date	2020/7/25
Test Frequency	CH58: 5290 MHz	Polarization	Vertical

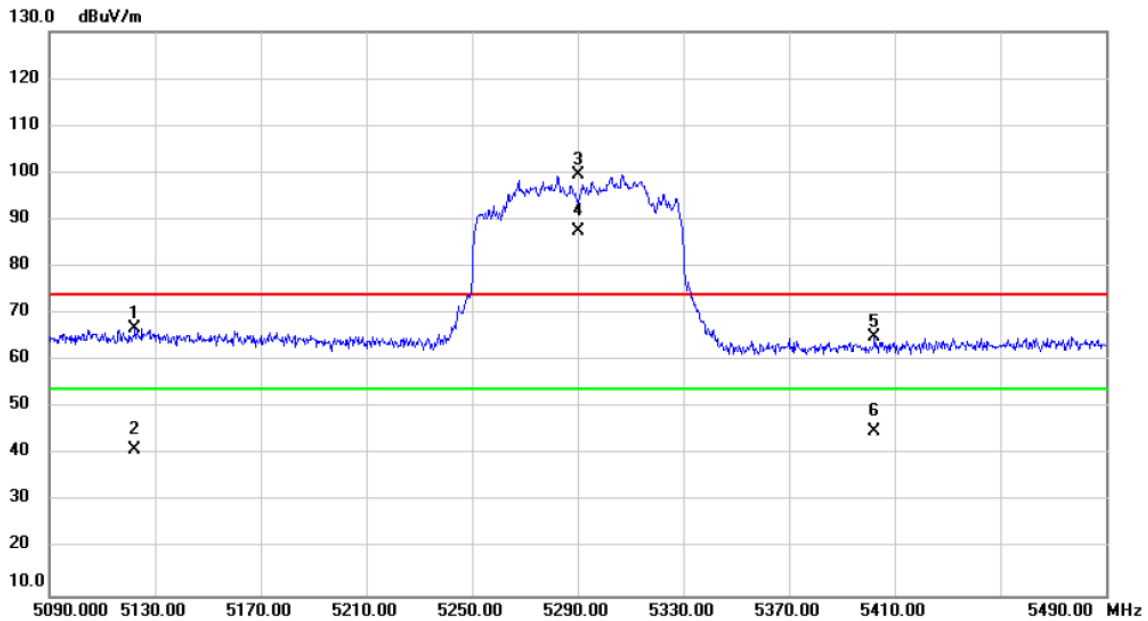

No.	Mk.	Freq.	Reading Level	Correct Factor	Measurement	Limit	Over	Detector	Comment
		MHz	dBuV	dB	dBuV/m	dBuV/m	dB		
1	X	5122.400	29.67	37.27	66.94	74.00	-7.06	peak	
2		5122.400	3.86	37.27	41.13	54.00	-12.87	AVG	
3	X	5290.000	61.99	37.42	99.41	74.00	25.41	peak	No Limit
4	*	5290.000	50.17	37.42	87.59	54.00	33.59	AVG	No Limit
5		5402.400	27.57	37.52	65.09	74.00	-8.91	peak	
6	X	5402.400	7.47	37.52	44.99	54.00	-9.01	AVG	

REMARKS:

- (1) Measurement Value = Reading Level + Correct Factor.
- (2) Margin Level = Measurement Value - Limit Value.

Test Mode	UNII-2C_IEEE 802.11ax (HE80)	Test Date	2020/7/25
Test Frequency	CH106: 5530 MHz	Polarization	Vertical

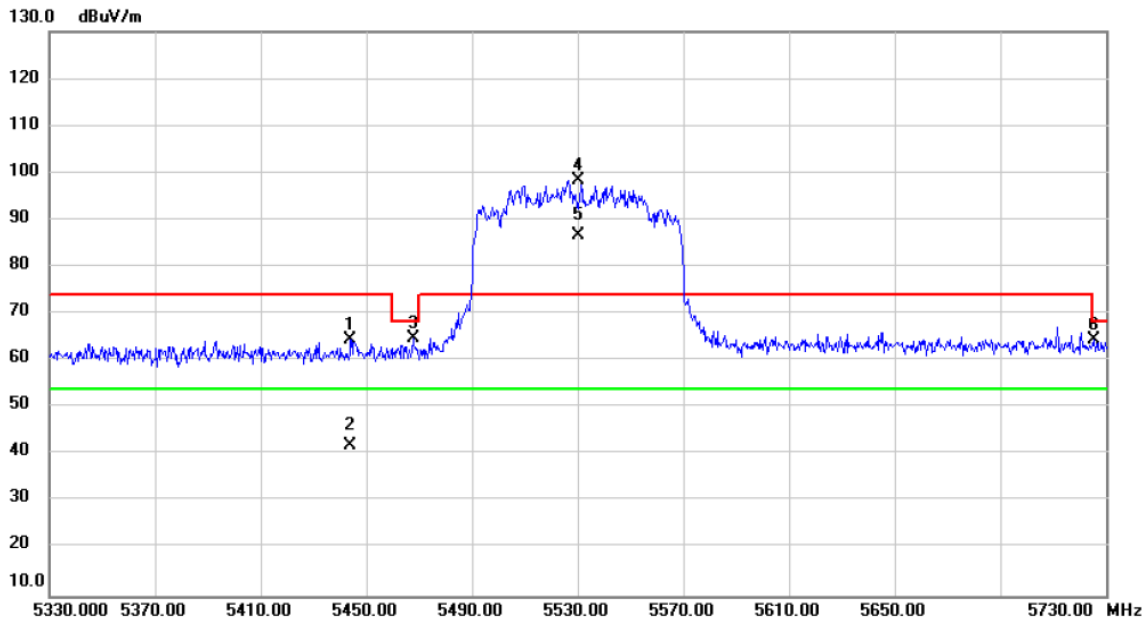

No.	Mk.	Freq. MHz	Reading Level dBuV	Correct Factor dB	Measure- ment dBuV/m	Limit dBuV/m	Over dB	Detector	Comment
1		5444.000	27.03	37.56	64.59	74.00	-9.41	peak	
2		5444.000	4.53	37.56	42.09	54.00	-11.91	AVG	
3		5467.600	27.11	37.58	64.69	68.20	-3.51	peak	
4	X	5530.000	60.59	37.68	98.27	74.00	24.27	peak	No Limit
5	*	5530.000	49.07	37.68	86.75	54.00	32.75	AVG	No Limit
6		5725.600	26.47	38.09	64.56	68.20	-3.64	peak	

REMARKS:

- (1) Measurement Value = Reading Level + Correct Factor.
- (2) Margin Level = Measurement Value - Limit Value.

Test Mode	UNII-2C_IEEE 802.11ax (HE80)	Test Date	2020/7/25
Test Frequency	CH122: 5610 MHz	Polarization	Vertical

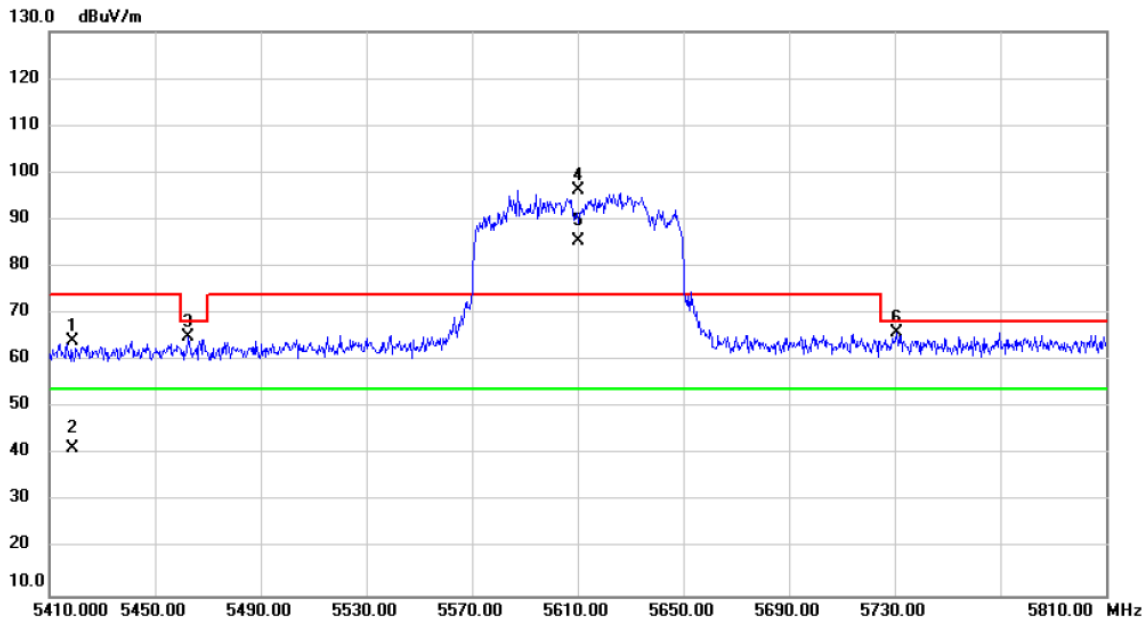

No.	Mk.	Freq. MHz	Reading Level dBuV	Correct Factor dB	Measure- ment dBuV/m	Limit dBuV/m	Over dB	Detector	Comment
1		5418.700	26.53	37.54	64.07	74.00	-9.93	peak	
2		5418.700	3.76	37.54	41.30	54.00	-12.70	AVG	
3		5462.400	27.45	37.58	65.03	68.20	-3.17	peak	
4	X	5610.000	58.27	37.84	96.11	74.00	22.11	peak	No Limit
5	*	5610.000	47.51	37.84	85.35	54.00	31.35	AVG	No Limit
6		5730.800	27.82	38.11	65.93	68.20	-2.27	peak	

REMARKS:

- (1) Measurement Value = Reading Level + Correct Factor.
- (2) Margin Level = Measurement Value - Limit Value.

Test Mode	UNII-3_IEEE 802.11ax (HE80)	Test Date	2020/7/25
Test Frequency	CH155: 5775 MHz	Polarization	Vertical

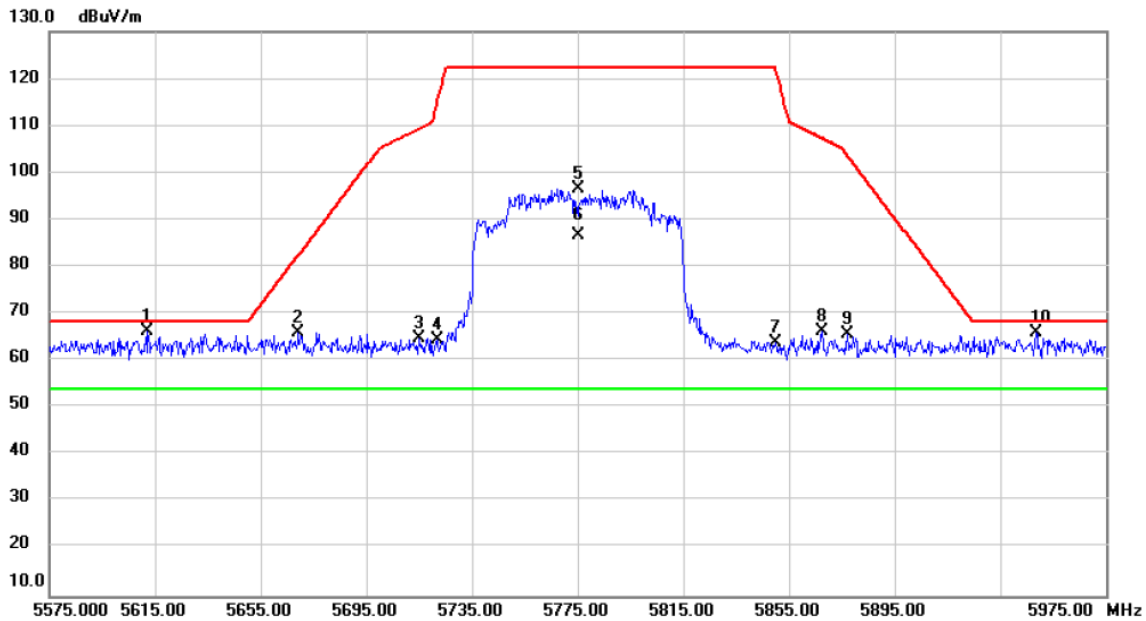

No.	Mk.	Freq.	Reading Level	Correct Factor	Measurement	Limit	Over	Detector	Comment
		MHz	dBuV	dB	dBuV/m	dBuV/m	dB		
1		5612.200	28.35	37.85	66.20	68.20	-2.00	peak	
2		5669.400	27.94	37.97	65.91	82.59	-16.68	peak	
3		5715.000	26.55	38.07	64.62	109.40	-44.78	peak	
4		5721.800	26.38	38.09	64.47	114.91	-50.44	peak	
5		5775.000	58.38	38.20	96.58	122.20	-25.62	peak	No Limit
6	*	5775.000	48.42	38.20	86.62	54.00	32.62	AVG	No Limit
7		5850.200	25.45	38.36	63.81	121.74	-57.93	peak	
8		5867.400	27.76	38.40	66.16	107.33	-41.17	peak	
9		5877.000	27.27	38.41	65.68	103.71	-38.03	peak	
10		5948.600	27.45	38.57	66.02	68.20	-2.18	peak	

REMARKS:

- (1) Measurement Value = Reading Level + Correct Factor.
- (2) Margin Level = Measurement Value - Limit Value.

Test Mode	UNII-1_IEEE 802.11ax (HE160)	Test Date	2020/7/25
Test Frequency	CH50: 5250 MHz	Polarization	Vertical

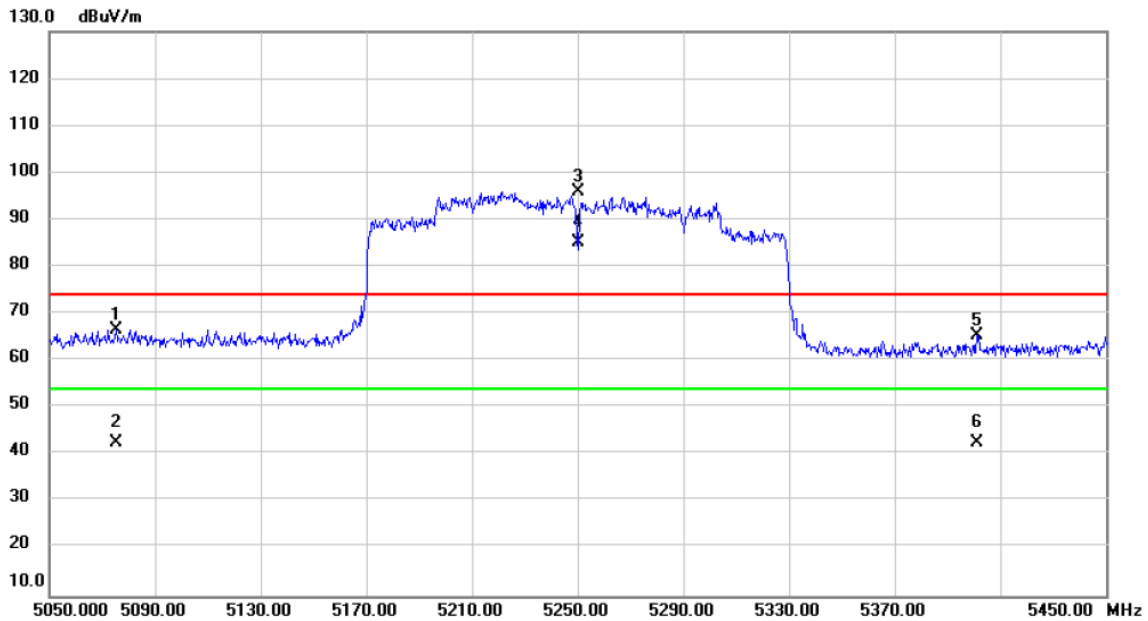

No.	Mk.	Freq.	Reading Level	Correct Factor	Measurement	Limit	Over	Detector	Comment
		MHz	dBuV	dB	dBuV/m	dBuV/m	dB		
1		5075.200	29.39	37.24	66.63	74.00	-7.37	peak	
2		5075.200	5.41	37.24	42.65	54.00	-11.35	AVG	
3	X	5250.000	58.46	37.39	95.85	74.00	21.85	peak	No Limit
4	*	5250.000	47.66	37.39	85.05	54.00	31.05	AVG	No Limit
5		5401.200	27.93	37.52	65.45	74.00	-8.55	peak	
6		5401.200	4.99	37.52	42.51	54.00	-11.49	AVG	

REMARKS:

- (1) Measurement Value = Reading Level + Correct Factor.
- (2) Margin Level = Measurement Value - Limit Value.

Test Mode	UNII-2C_ IEEE 802.11ax (HE160)	Test Date	2020/7/25
Test Frequency	CH114: 5570 MHz	Polarization	Vertical

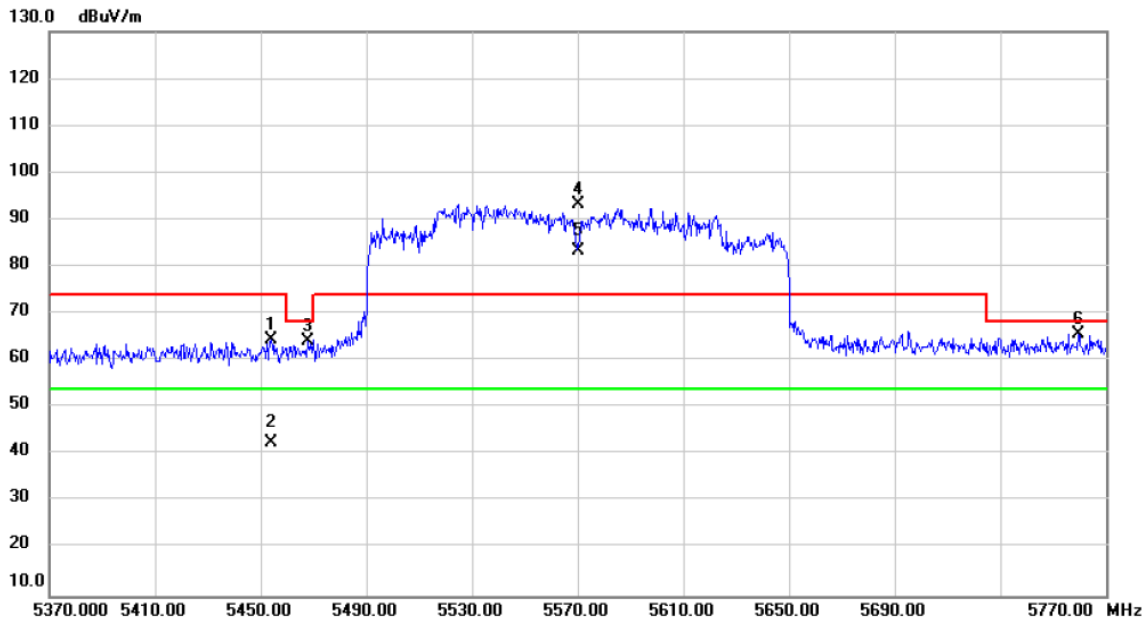

No.	Mk.	Freq.	Reading Level	Correct Factor	Measurement	Limit	Over	Detector	Comment
		MHz	dBuV	dB	dBuV/m	dBuV/m	dB		
1		5454.000	26.93	37.57	64.50	74.00	-9.50	peak	
2		5454.000	4.90	37.57	42.47	54.00	-11.53	AVG	
3		5467.600	26.62	37.58	64.20	68.20	-4.00	peak	
4	X	5570.000	55.43	37.76	93.19	74.00	19.19	peak	No Limit
5	*	5570.000	45.44	37.76	83.20	54.00	29.20	AVG	No Limit
6		5759.600	27.57	38.16	65.73	68.20	-2.47	peak	

REMARKS:

- (1) Measurement Value = Reading Level + Correct Factor.
- (2) Margin Level = Measurement Value - Limit Value.

Test Mode	UNII-1_IEEE 802.11a	Test Date	2020/7/27
Test Frequency	CH36: 5180 MHz	Polarization	Vertical

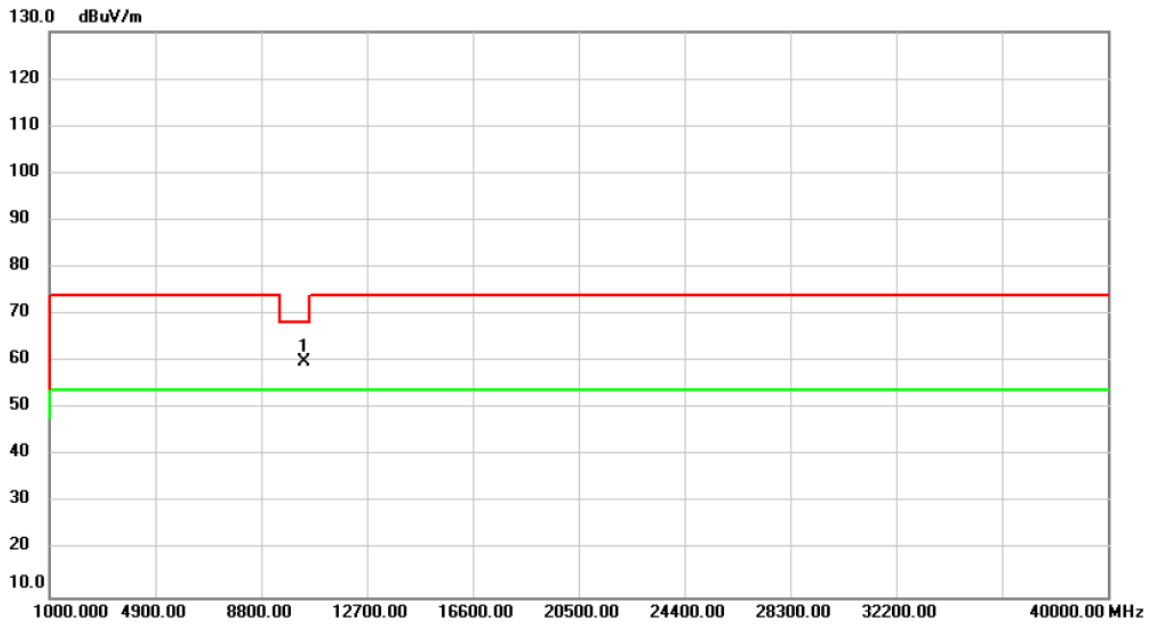

No.	Mk.	Freq.	Reading Level	Correct Factor	Measurement	Limit	Over	Detector	Comment
		MHz	dBuV	dB	dBuV/m	dBuV/m	dB		
1	*	10360.00	55.05	4.85	59.90	68.20	-8.30	peak	

REMARKS:

- (1) Measurement Value = Reading Level + Correct Factor.
- (2) Margin Level = Measurement Value - Limit Value.

Test Mode	UNII-1_IEEE 802.11a	Test Date	2020/7/27
Test Frequency	CH36: 5180 MHz	Polarization	Horizontal

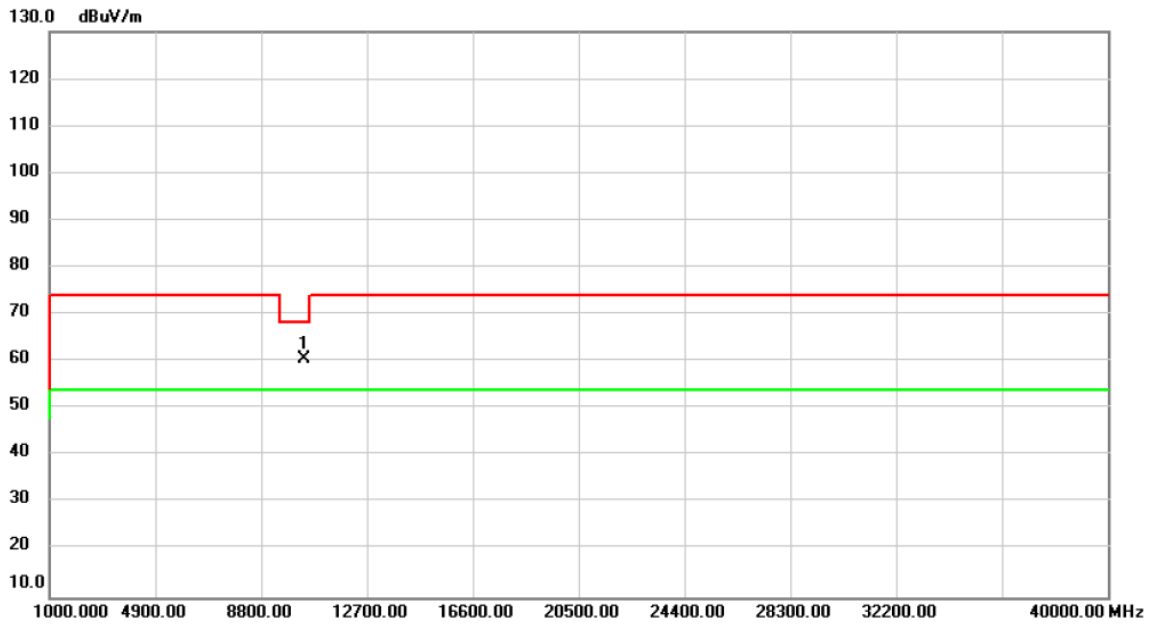

No.	Mk.	Freq.	Reading Level	Correct Factor	Measurement	Limit	Over	Detector	Comment
		MHz	dBuV	dB	dBuV/m	dBuV/m	dB		
1	*	10360.00	55.82	4.85	60.67	68.20	-7.53	peak	

REMARKS:

- (1) Measurement Value = Reading Level + Correct Factor.
- (2) Margin Level = Measurement Value - Limit Value.

Test Mode	UNII-1_IEEE 802.11a	Test Date	2020/7/27
Test Frequency	CH40: 5200 MHz	Polarization	Vertical

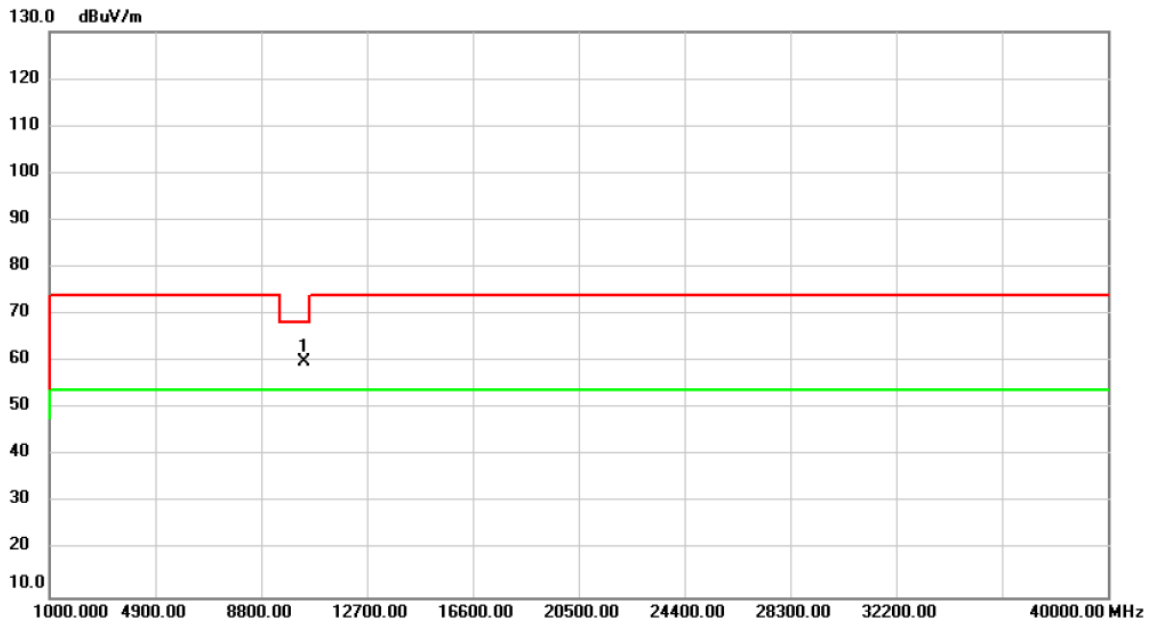

No.	Mk.	Freq.	Reading Level	Correct Factor	Measurement	Limit	Over	Detector	Comment
		MHz	dBuV	dB	dBuV/m	dBuV/m	dB		
1	*	10400.00	54.92	4.94	59.86	68.20	-8.34	peak	

REMARKS:

- (1) Measurement Value = Reading Level + Correct Factor.
- (2) Margin Level = Measurement Value - Limit Value.

Test Mode	UNII-1_IEEE 802.11a	Test Date	2020/7/27
Test Frequency	CH40: 5200 MHz	Polarization	Horizontal

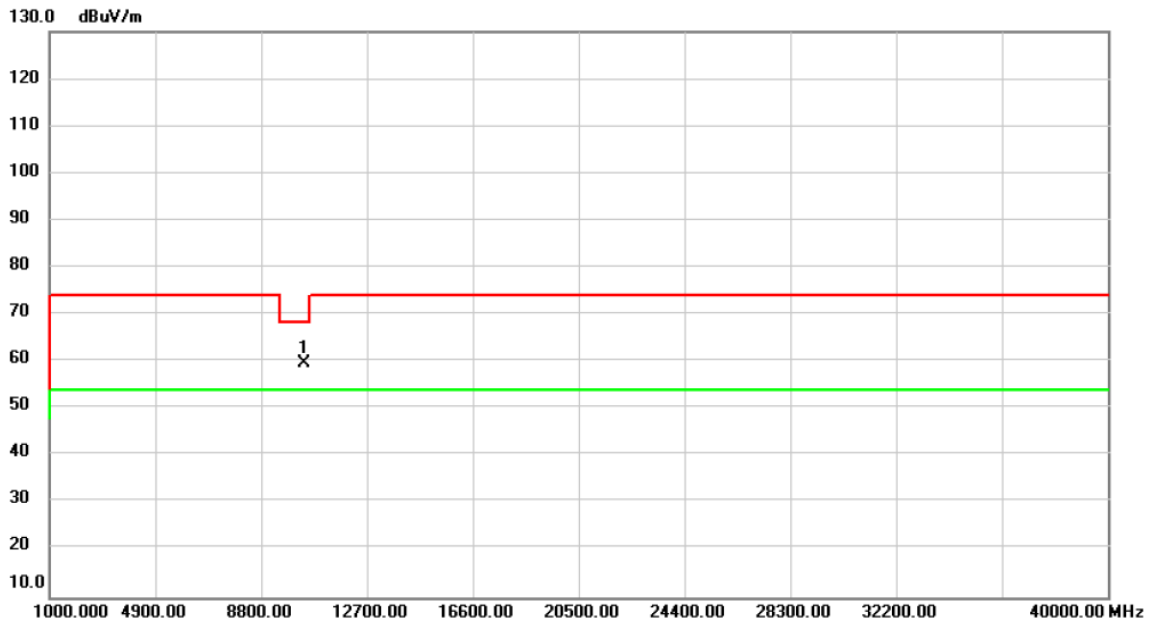

No.	Mk.	Freq.	Reading Level	Correct Factor	Measurement	Limit	Over	Detector	Comment
		MHz	dBuV	dB	dBuV/m	dBuV/m	dB		
1	*	10400.00	54.80	4.94	59.74	68.20	-8.46	peak	

REMARKS:

- (1) Measurement Value = Reading Level + Correct Factor.
- (2) Margin Level = Measurement Value - Limit Value.

Test Mode	UNII-1_IEEE 802.11a	Test Date	2020/7/27
Test Frequency	CH48: 5240 MHz	Polarization	Vertical

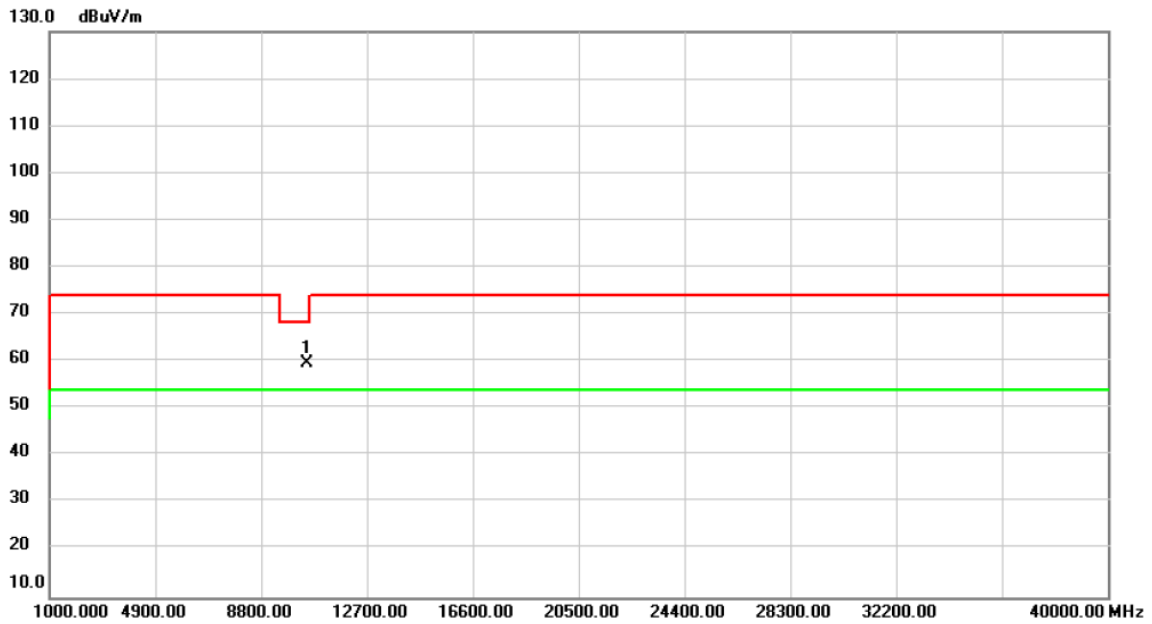

No.	Mk.	Freq.	Reading Level	Correct Factor	Measurement	Limit	Over	Detector	Comment
		MHz	dBuV	dB	dBuV/m	dBuV/m	dB		
1	*	10480.00	54.62	5.15	59.77	68.20	-8.43	peak	

REMARKS:

- (1) Measurement Value = Reading Level + Correct Factor.
- (2) Margin Level = Measurement Value - Limit Value.

Test Mode	UNII-1_IEEE 802.11a	Test Date	2020/7/27
Test Frequency	CH48: 5240 MHz	Polarization	Horizontal

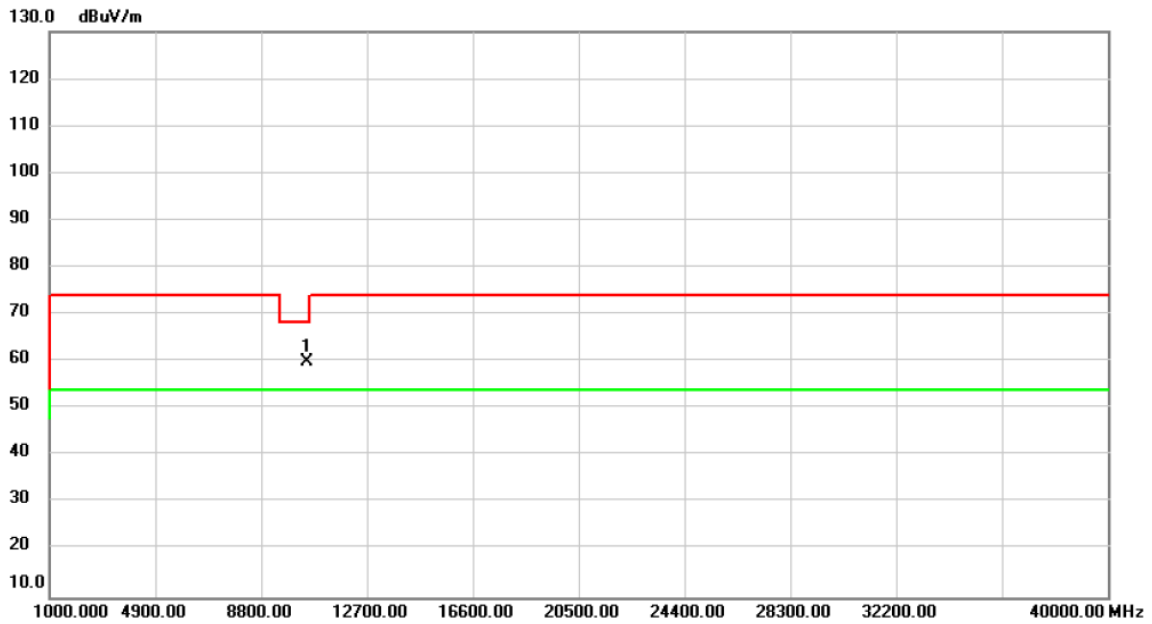

No.	Mk.	Freq.	Reading Level	Correct Factor	Measurement	Limit	Over	Detector	Comment
		MHz	dBuV	dB	dBuV/m	dBuV/m	dB		
1	*	10480.00	54.81	5.15	59.96	68.20	-8.24	peak	

REMARKS:

- (1) Measurement Value = Reading Level + Correct Factor.
- (2) Margin Level = Measurement Value - Limit Value.

Test Mode	UNII-2A_ IEEE 802.11a	Test Date	2020/7/27
Test Frequency	CH52: 5260 MHz	Polarization	Vertical

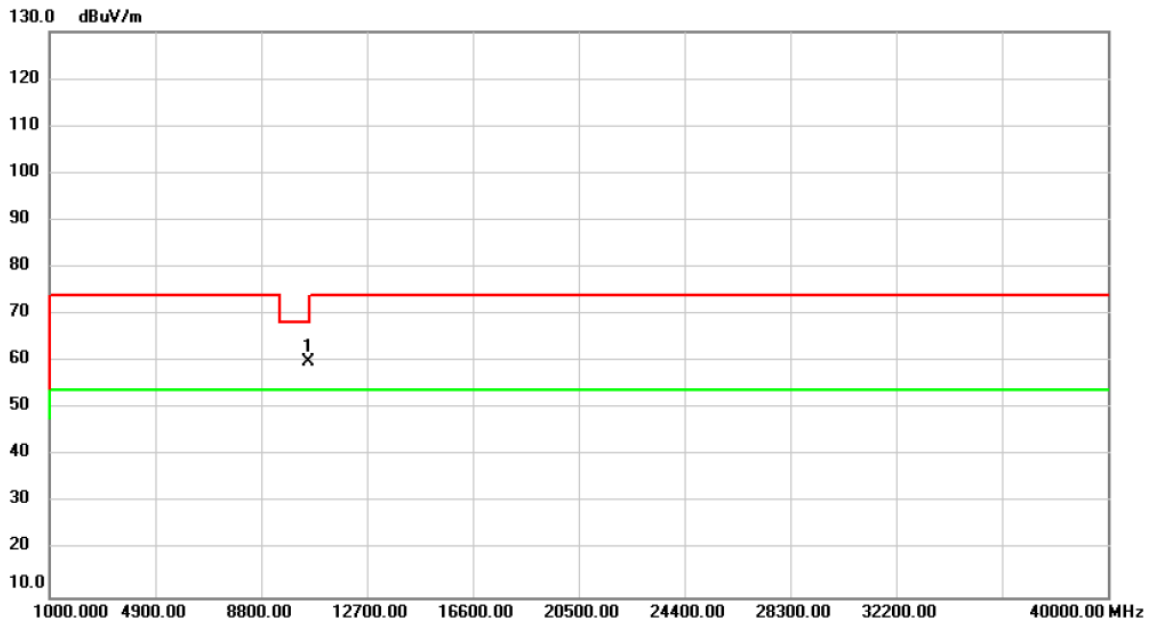

No.	Mk.	Freq.	Reading Level	Correct Factor	Measurement	Limit	Over	Detector	Comment
		MHz	dBuV	dB	dBuV/m	dBuV/m	dB		
1	*	10520.00	54.62	5.24	59.86	68.20	-8.34	peak	

REMARKS:

- (1) Measurement Value = Reading Level + Correct Factor.
- (2) Margin Level = Measurement Value - Limit Value.

Test Mode	UNII-2A_ IEEE 802.11a	Test Date	2020/7/27
Test Frequency	CH52: 5260 MHz	Polarization	Horizontal

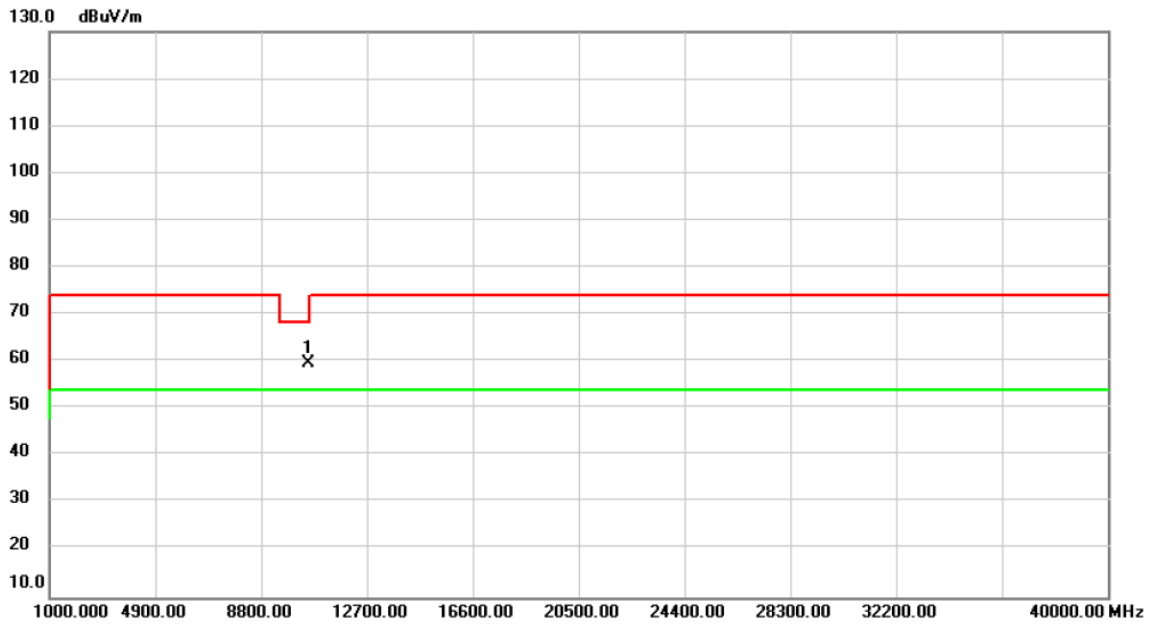

No.	Mk.	Freq.	Reading Level	Correct Factor	Measurement	Limit	Over	Detector	Comment
		MHz	dBuV	dB	dBuV/m	dBuV/m	dB		
1	*	10520.00	54.34	5.24	59.58	68.20	-8.62	peak	

REMARKS:

- (1) Measurement Value = Reading Level + Correct Factor.
- (2) Margin Level = Measurement Value - Limit Value.

Test Mode	UNII-2A_ IEEE 802.11a	Test Date	2020/7/27
Test Frequency	CH60: 5300 MHz	Polarization	Vertical

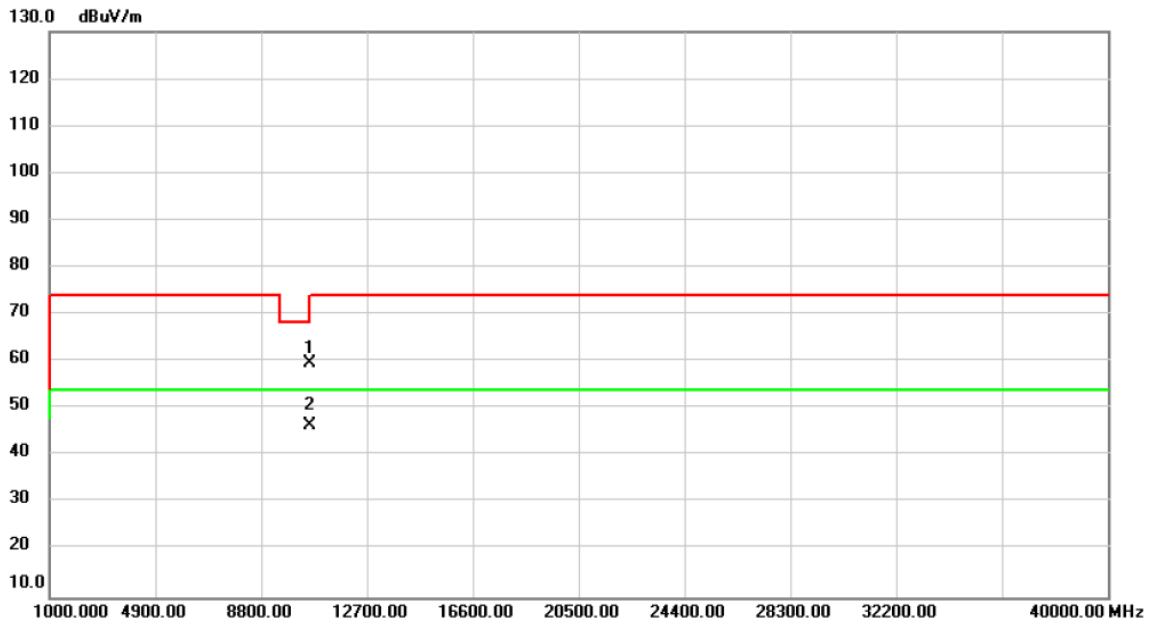

No.	Mk.	Freq.	Reading Level	Correct Factor	Measurement	Limit	Over	Detector	Comment
		MHz	dBuV	dB	dBuV/m	dBuV/m	dB		
1		10600.00	54.14	5.41	59.55	68.20	-8.65	peak	
2	*	10600.00	40.96	5.41	46.37	54.00	-7.63	AVG	

REMARKS:

- (1) Measurement Value = Reading Level + Correct Factor.
- (2) Margin Level = Measurement Value - Limit Value.

Test Mode	UNII-2A_ IEEE 802.11a	Test Date	2020/7/27
Test Frequency	CH60: 5300 MHz	Polarization	Horizontal

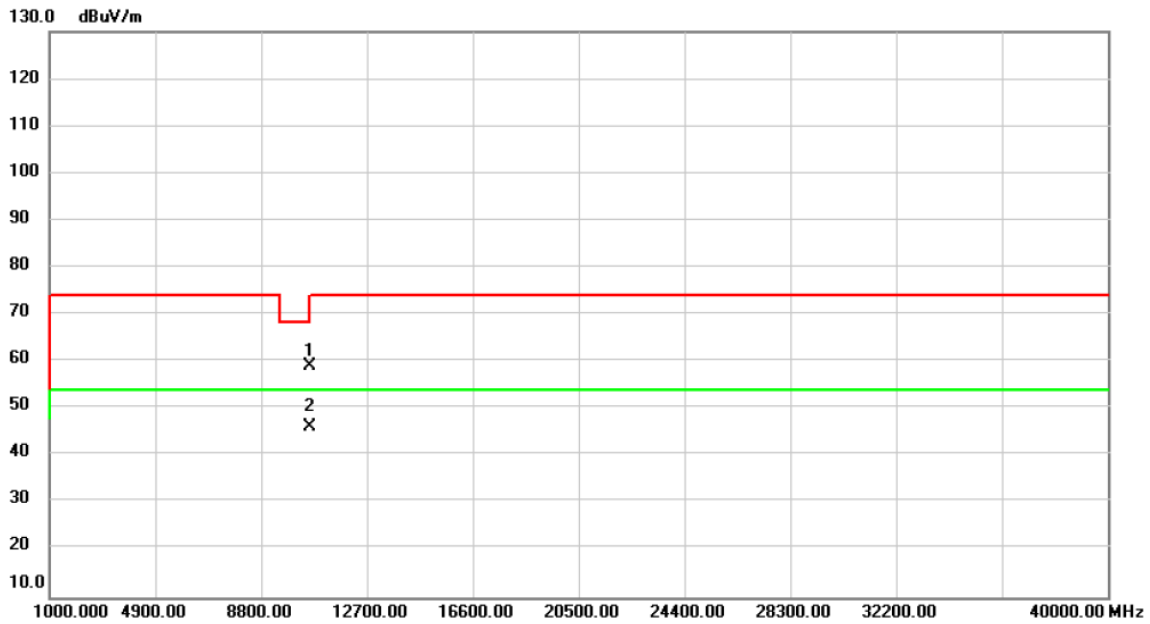

No.	Mk.	Freq.	Reading Level	Correct Factor	Measurement	Limit	Over	Detector	Comment
		MHz	dBuV	dB	dBuV/m	dBuV/m	dB		
1		10600.00	53.57	5.41	58.98	68.20	-9.22	peak	
2	*	10600.00	40.66	5.41	46.07	54.00	-7.93	AVG	

REMARKS:

- (1) Measurement Value = Reading Level + Correct Factor.
- (2) Margin Level = Measurement Value - Limit Value.

Test Mode	UNII-2A_ IEEE 802.11a	Test Date	2020/7/27
Test Frequency	CH64: 5320 MHz	Polarization	Vertical

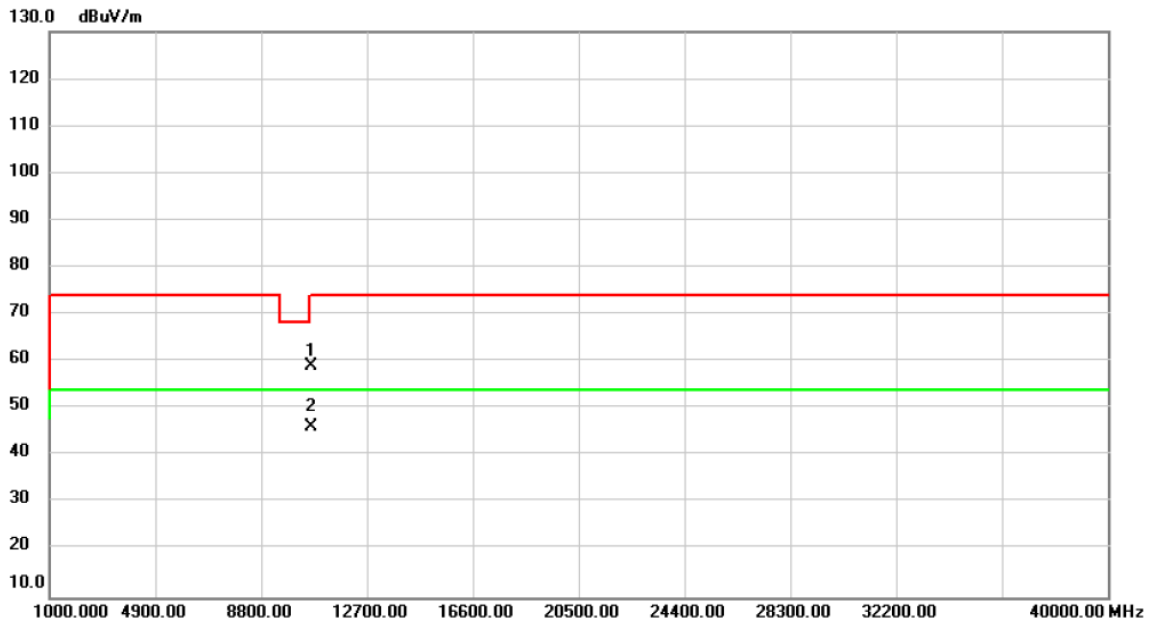

No.	Mk.	Freq.	Reading Level	Correct Factor	Measurement	Limit	Over	Detector	Comment
		MHz	dBuV	dB	dBuV/m	dBuV/m	dB		
1		10640.00	53.52	5.49	59.01	74.00	-14.99	peak	
2	*	10640.00	40.65	5.49	46.14	54.00	-7.86	AVG	

REMARKS:

- (1) Measurement Value = Reading Level + Correct Factor.
- (2) Margin Level = Measurement Value - Limit Value.

Test Mode	UNII-2A_ IEEE 802.11a	Test Date	2020/7/27
Test Frequency	CH64: 5320 MHz	Polarization	Horizontal

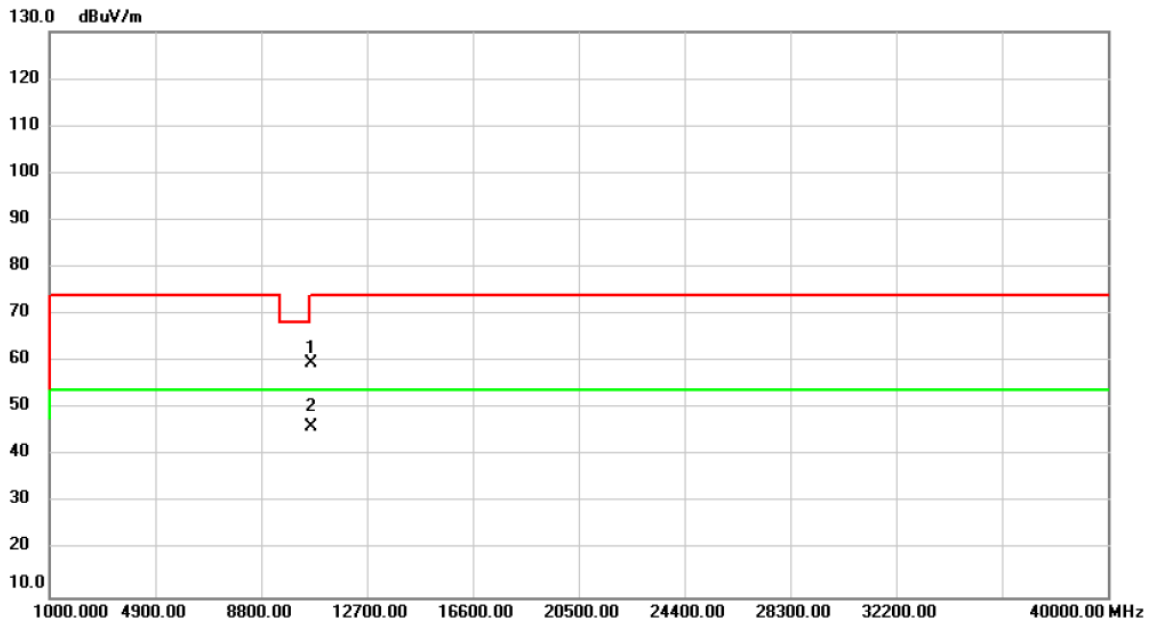

No.	Mk.	Freq.	Reading Level	Correct Factor	Measurement	Limit	Over	Detector	Comment
		MHz	dBuV	dB	dBuV/m	dBuV/m	dB		
1		10640.00	54.25	5.49	59.74	74.00	-14.26	peak	
2	*	10640.00	40.59	5.49	46.08	54.00	-7.92	AVG	

REMARKS:

- (1) Measurement Value = Reading Level + Correct Factor.
- (2) Margin Level = Measurement Value - Limit Value.

Test Mode	UNII-2C_IEEE 802.11a	Test Date	2020/7/27
Test Frequency	CH100: 5500 MHz	Polarization	Vertical

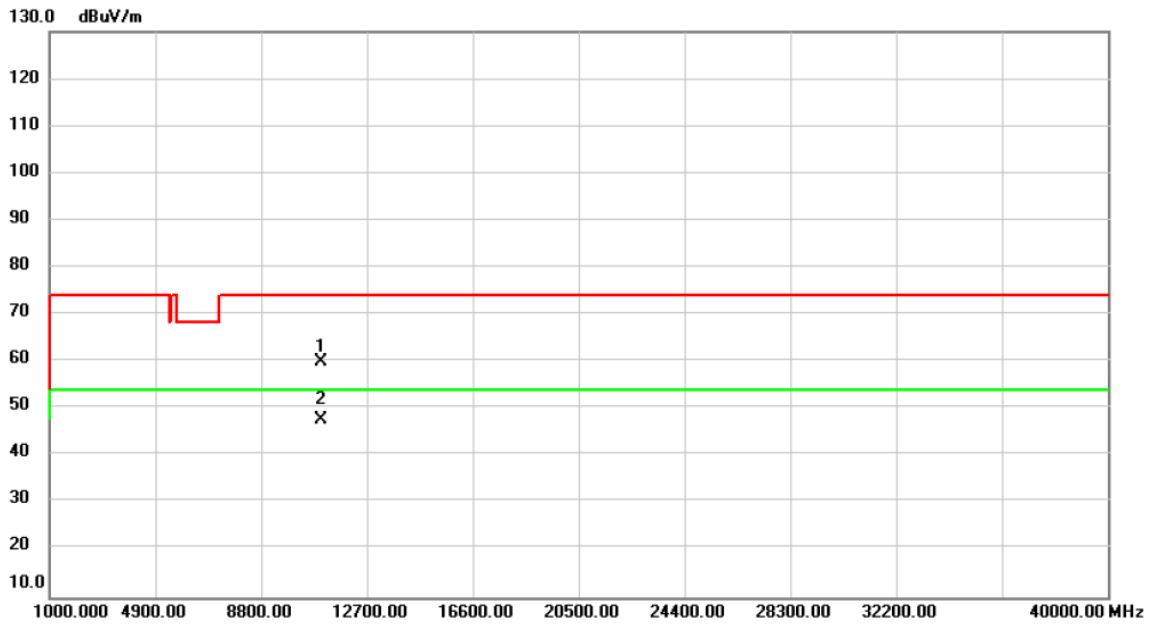

No.	Mk.	Freq.	Reading Level	Correct Factor	Measurement	Limit	Over	Detector	Comment
		MHz	dBuV	dB	dBuV/m	dBuV/m	dB		
1		11000.00	53.84	6.24	60.08	74.00	-13.92	peak	
2	*	11000.00	41.39	6.24	47.63	54.00	-6.37	AVG	

REMARKS:

- (1) Measurement Value = Reading Level + Correct Factor.
- (2) Margin Level = Measurement Value - Limit Value.

Test Mode	UNII-2C_ IEEE 802.11a	Test Date	2020/7/27
Test Frequency	CH100: 5500 MHz	Polarization	Horizontal

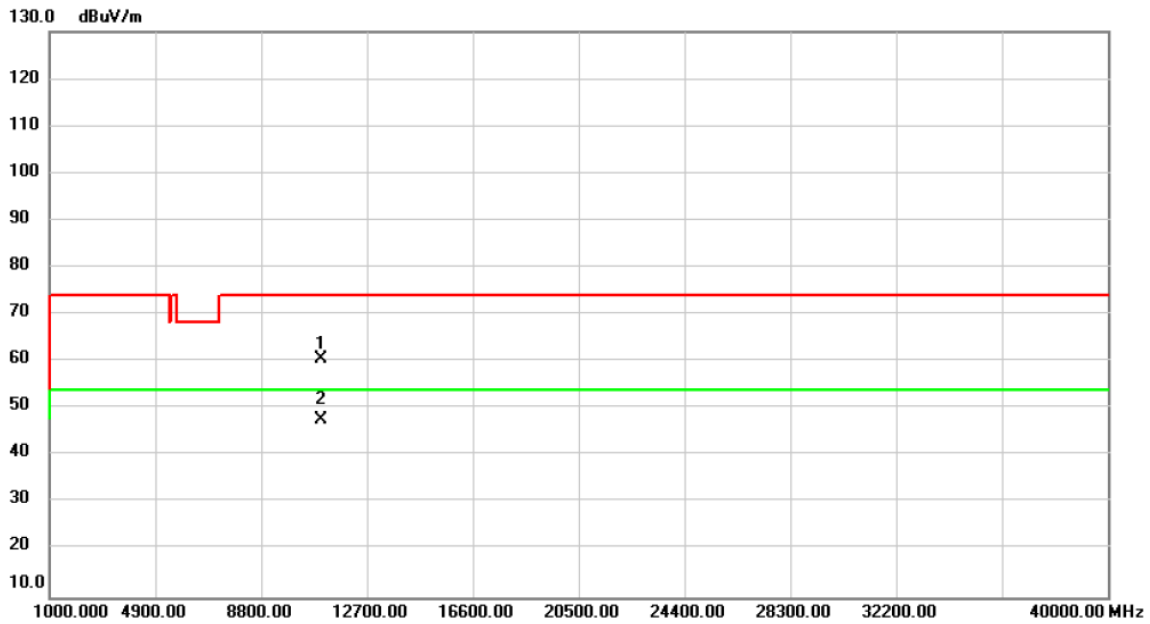

No.	Mk.	Freq.	Reading Level	Correct Factor	Measurement	Limit	Over	Detector	Comment
		MHz	dBuV	dB	dBuV/m	dBuV/m	dB		
1		11000.00	54.45	6.24	60.69	74.00	-13.31	peak	
2	*	11000.00	41.33	6.24	47.57	54.00	-6.43	AVG	

REMARKS:

- (1) Measurement Value = Reading Level + Correct Factor.
- (2) Margin Level = Measurement Value - Limit Value.

Test Mode	UNII-2C_ IEEE 802.11a	Test Date	2020/7/27
Test Frequency	CH116: 5580 MHz	Polarization	Vertical

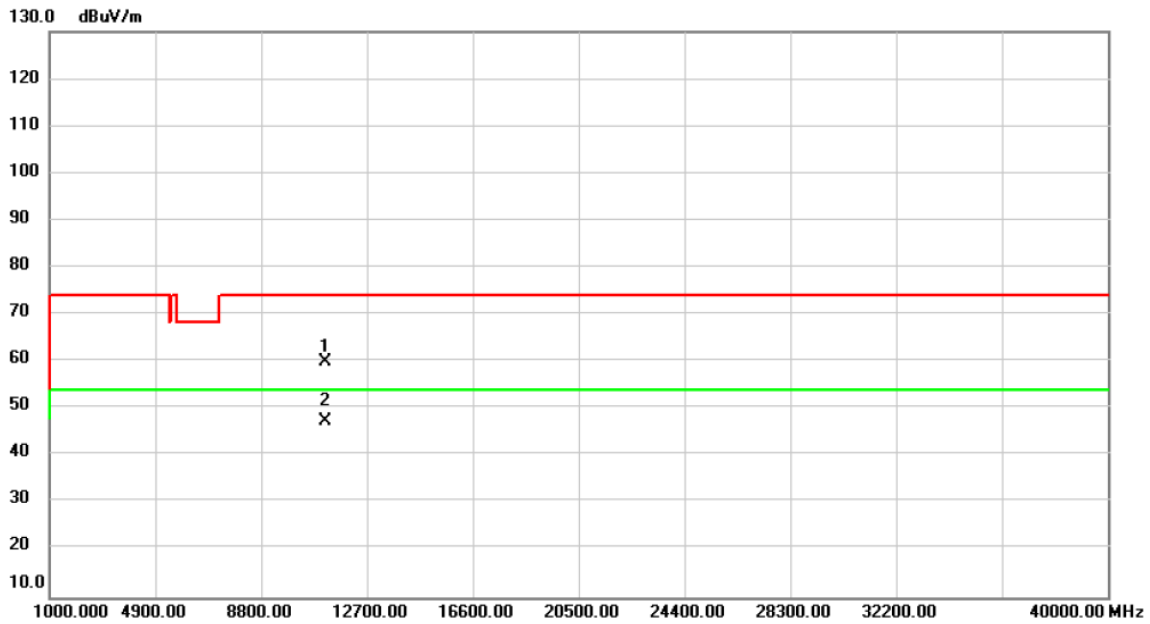

No.	Mk.	Freq.	Reading Level	Correct Factor	Measurement	Limit	Over	Detector	Comment
		MHz	dBuV	dB	dBuV/m	dBuV/m	dB		
1		11160.00	54.11	5.85	59.96	74.00	-14.04	peak	
2	*	11160.00	41.51	5.85	47.36	54.00	-6.64	AVG	

REMARKS:

- (1) Measurement Value = Reading Level + Correct Factor.
- (2) Margin Level = Measurement Value - Limit Value.

Test Mode	UNII-2C_ IEEE 802.11a	Test Date	2020/7/27
Test Frequency	CH116: 5580 MHz	Polarization	Horizontal

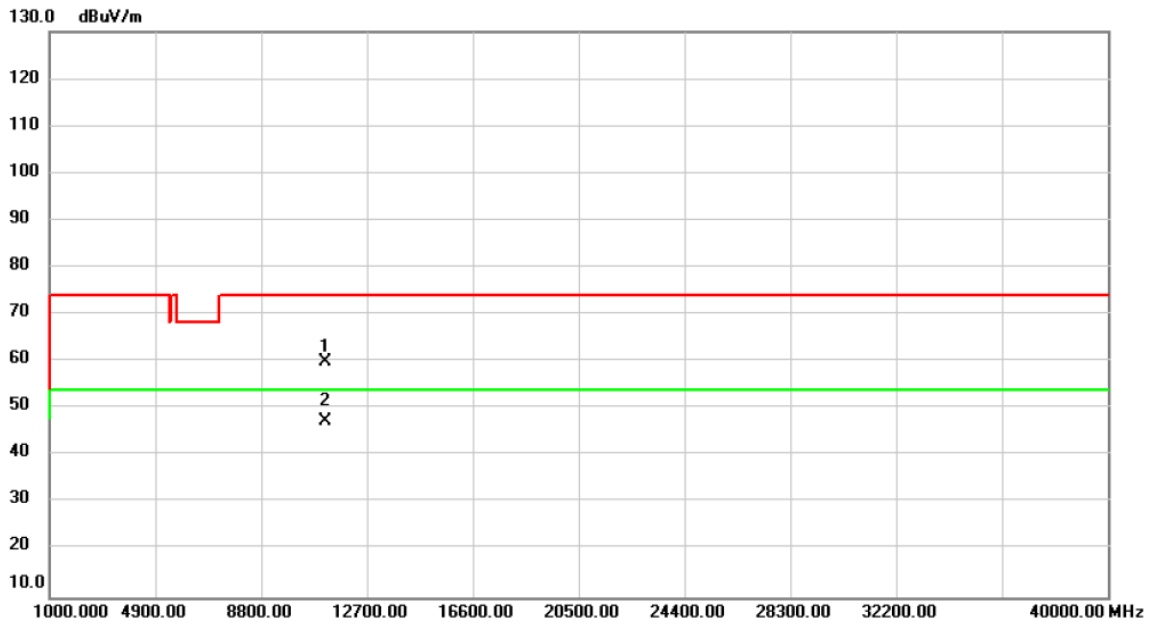

No.	Mk.	Freq. MHz	Reading Level dBuV	Correct Factor dB	Measure- ment dBuV/m	Limit dBuV/m	Over dB	Detector	Comment
1		11160.00	54.08	5.85	59.93	74.00	-14.07	peak	
2	*	11160.00	41.52	5.85	47.37	54.00	-6.63	AVG	

REMARKS:

- (1) Measurement Value = Reading Level + Correct Factor.
- (2) Margin Level = Measurement Value - Limit Value.

Test Mode	UNII-2C_IEEE 802.11a	Test Date	2020/7/27
Test Frequency	CH140: 5700 MHz	Polarization	Vertical

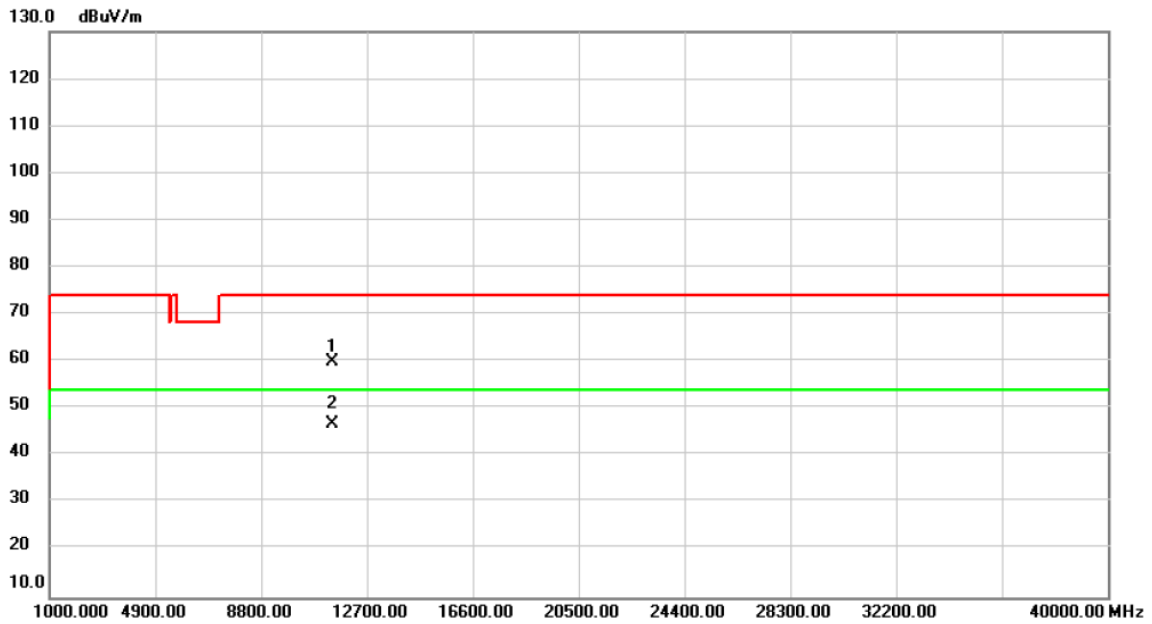

No.	Mk.	Freq.	Reading Level	Correct Factor	Measurement	Limit	Over	Detector	Comment
		MHz	dBuV	dB	dBuV/m	dBuV/m	dB		
1		11400.00	54.77	5.27	60.04	74.00	-13.96	peak	
2	*	11400.00	41.51	5.27	46.78	54.00	-7.22	AVG	

REMARKS:

- (1) Measurement Value = Reading Level + Correct Factor.
- (2) Margin Level = Measurement Value - Limit Value.

Test Mode	UNII-2C_IEEE 802.11a	Test Date	2020/7/27
Test Frequency	CH140: 5700 MHz	Polarization	Horizontal

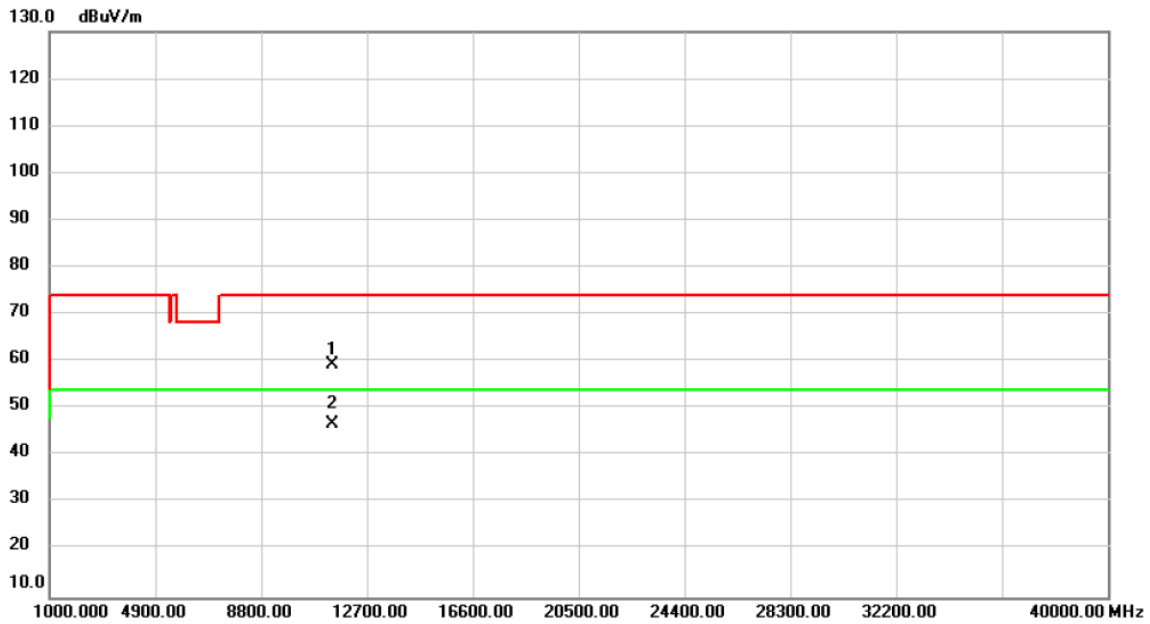

No.	Mk.	Freq.	Reading Level	Correct Factor	Measurement	Limit	Over	Detector	Comment
		MHz	dBuV	dB	dBuV/m	dBuV/m	dB		
1		11400.00	53.96	5.27	59.23	74.00	-14.77	peak	
2	*	11400.00	41.51	5.27	46.78	54.00	-7.22	AVG	

REMARKS:

- (1) Measurement Value = Reading Level + Correct Factor.
- (2) Margin Level = Measurement Value - Limit Value.

Test Mode	UNII-3_IEEE 802.11a	Test Date	2020/7/27
Test Frequency	CH149: 5745 MHz	Polarization	Vertical

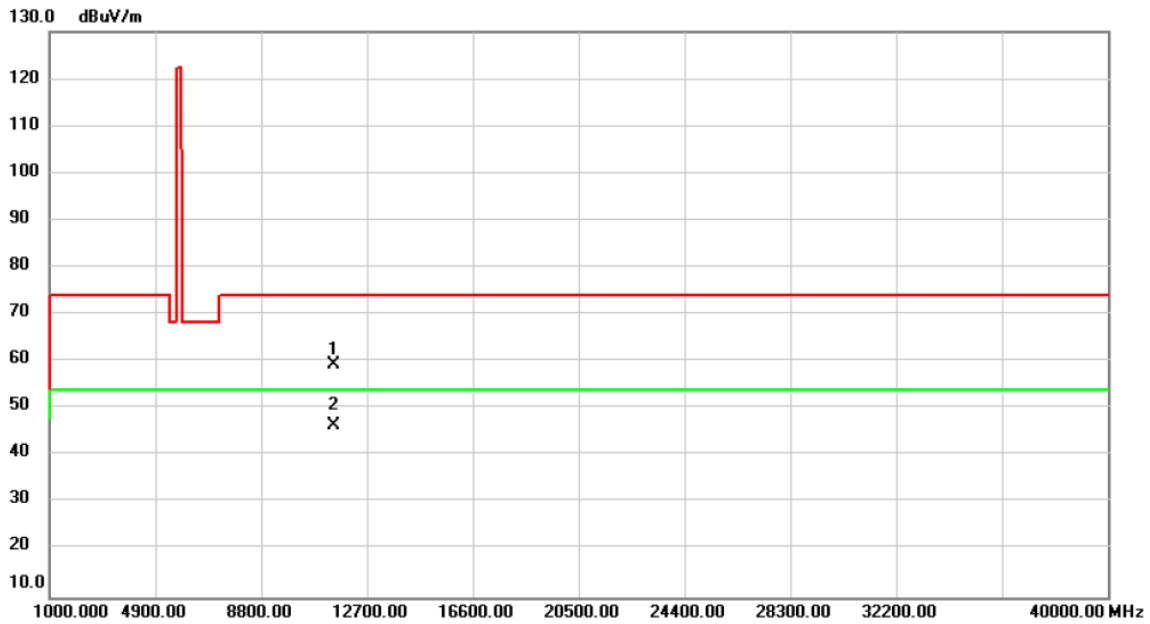

No.	Mk.	Freq. MHz	Reading Level dBuV	Correct Factor dB	Measure- ment dBuV/m	Limit dBuV/m	Over dB	Detector	Comment
1		11490.00	54.42	5.05	59.47	74.00	-14.53	peak	
2	*	11490.00	41.32	5.05	46.37	54.00	-7.63	AVG	

REMARKS:

- (1) Measurement Value = Reading Level + Correct Factor.
- (2) Margin Level = Measurement Value - Limit Value.

Test Mode	UNII-3_IEEE 802.11a	Test Date	2020/7/27
Test Frequency	CH149: 5745 MHz	Polarization	Horizontal

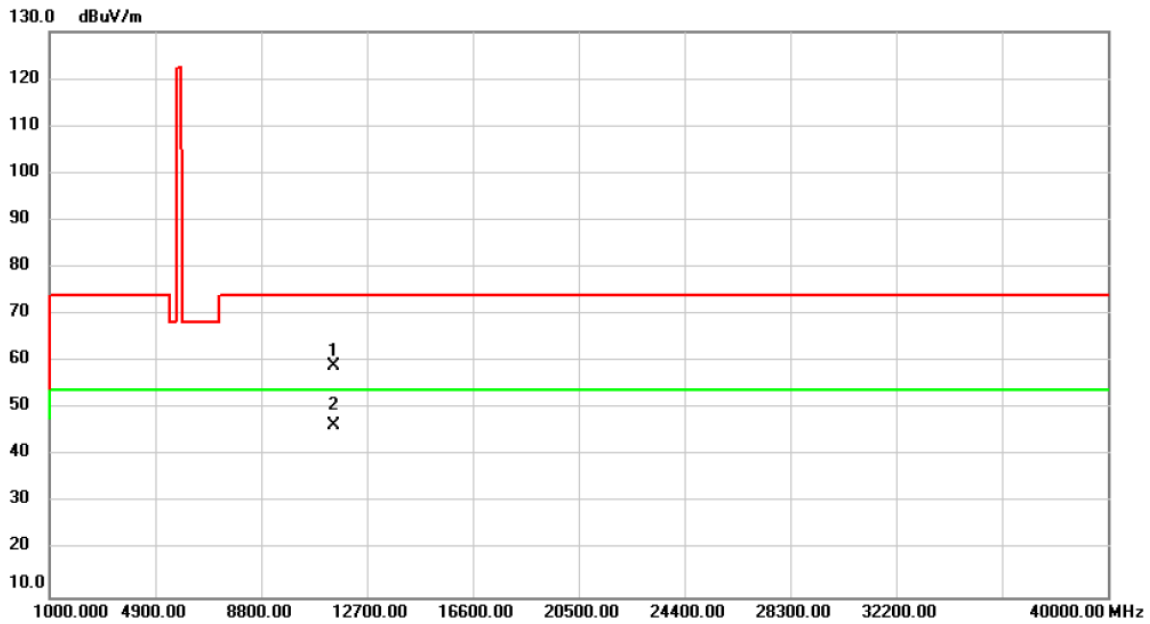

No.	Mk.	Freq. MHz	Reading Level dBuV	Correct Factor dB	Measure- ment dBuV/m	Limit dBuV/m	Over dB	Detector	Comment
1		11490.00	53.97	5.05	59.02	74.00	-14.98	peak	
2	*	11490.00	41.33	5.05	46.38	54.00	-7.62	AVG	

REMARKS:

- (1) Measurement Value = Reading Level + Correct Factor.
- (2) Margin Level = Measurement Value - Limit Value.

Test Mode	UNII-3_IIEEE 802.11a	Test Date	2020/7/27
Test Frequency	CH157: 5785 MHz	Polarization	Vertical

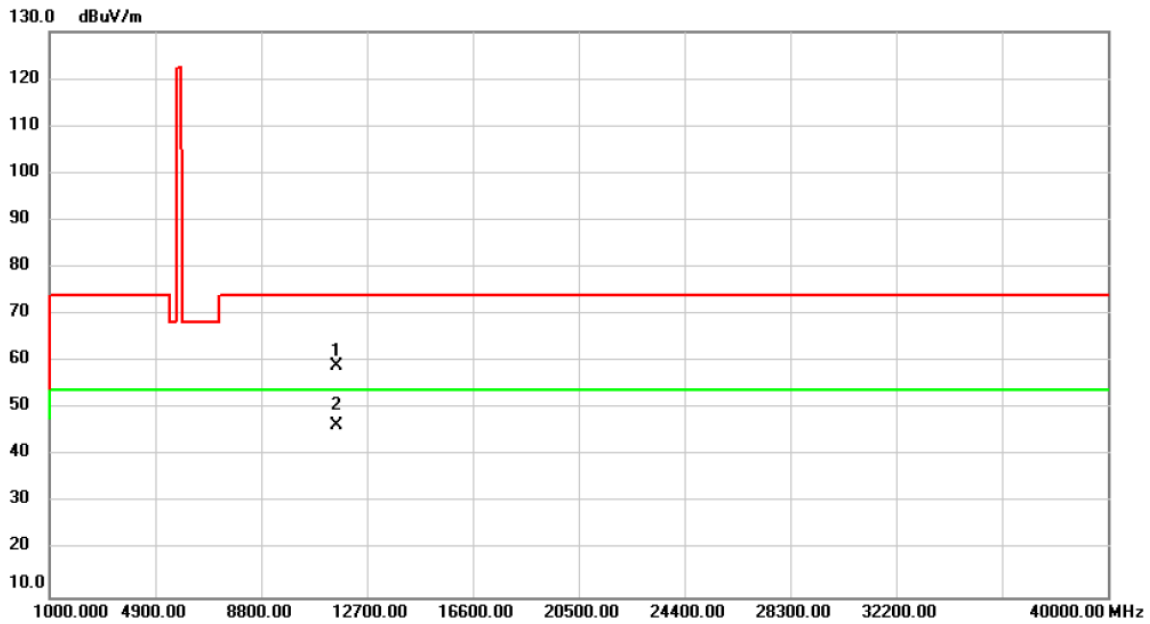

No.	Mk.	Freq.	Reading Level	Correct Factor	Measurement	Limit	Over	Detector	Comment
		MHz	dBuV	dB	dBuV/m	dBuV/m	dB		
1		11570.00	54.20	4.87	59.07	74.00	-14.93	peak	
2	*	11570.00	41.53	4.87	46.40	54.00	-7.60	AVG	

REMARKS:

- (1) Measurement Value = Reading Level + Correct Factor.
- (2) Margin Level = Measurement Value - Limit Value.

Test Mode	UNII-3_IIEEE 802.11a	Test Date	2020/7/27
Test Frequency	CH157: 5785 MHz	Polarization	Horizontal

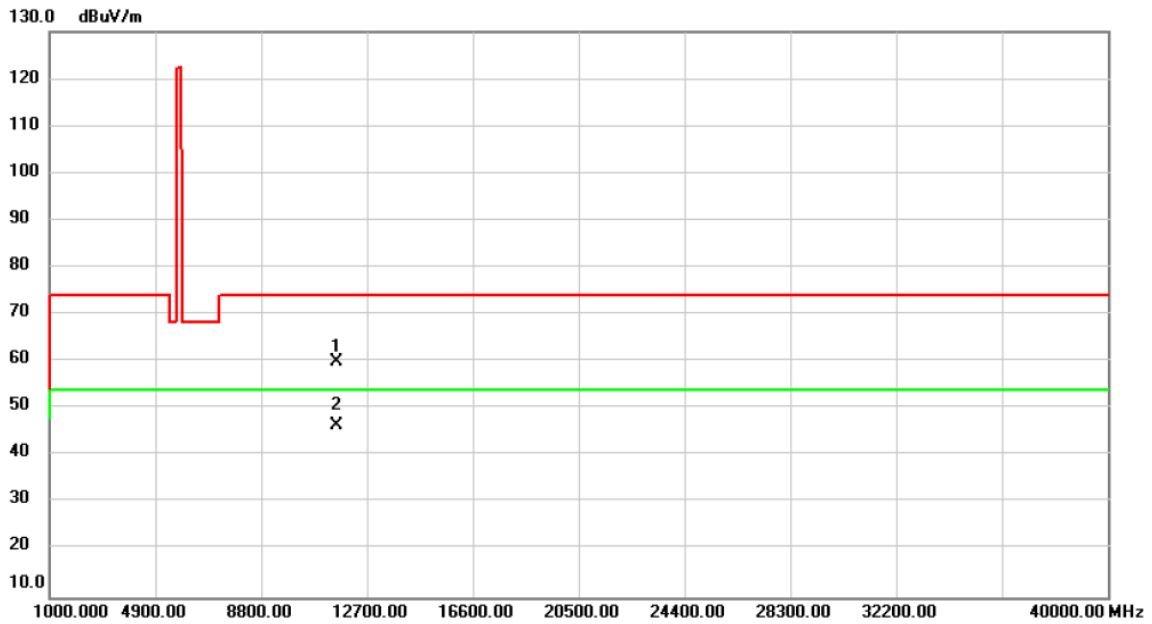

No.	Mk.	Freq.	Reading Level	Correct Factor	Measurement	Limit	Over	Detector	Comment
		MHz	dBuV	dB	dBuV/m	dBuV/m	dB		
1		11570.00	55.09	4.87	59.96	74.00	-14.04	peak	
2	*	11570.00	41.52	4.87	46.39	54.00	-7.61	AVG	

REMARKS:

- (1) Measurement Value = Reading Level + Correct Factor.
- (2) Margin Level = Measurement Value - Limit Value.

Test Mode	UNII-3_IIEEE 802.11a	Test Date	2020/7/27
Test Frequency	CH165: 5825 MHz	Polarization	Vertical

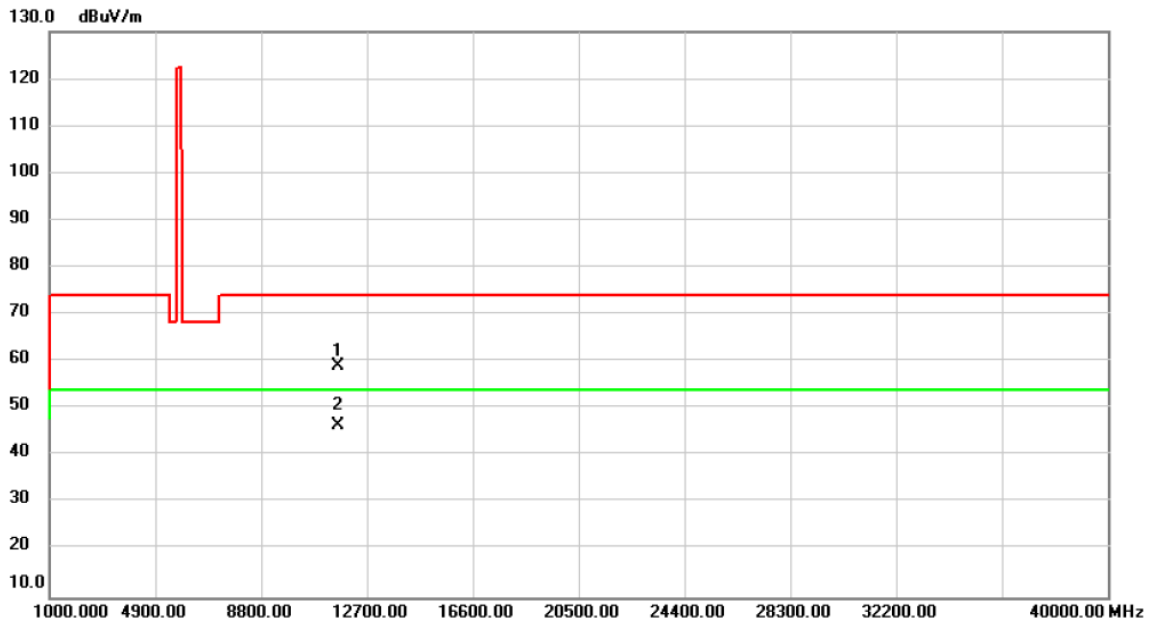

No.	Mk.	Freq.	Reading Level	Correct Factor	Measurement	Limit	Over	Detector	Comment
		MHz	dBuV	dB	dBuV/m	dBuV/m	dB		
1		11650.00	54.22	4.69	58.91	74.00	-15.09	peak	
2	*	11650.00	41.74	4.69	46.43	54.00	-7.57	AVG	

REMARKS:

- (1) Measurement Value = Reading Level + Correct Factor.
- (2) Margin Level = Measurement Value - Limit Value.

Test Mode	UNII-3_IEEE 802.11a	Test Date	2020/7/27
Test Frequency	CH165: 5825 MHz	Polarization	Horizontal

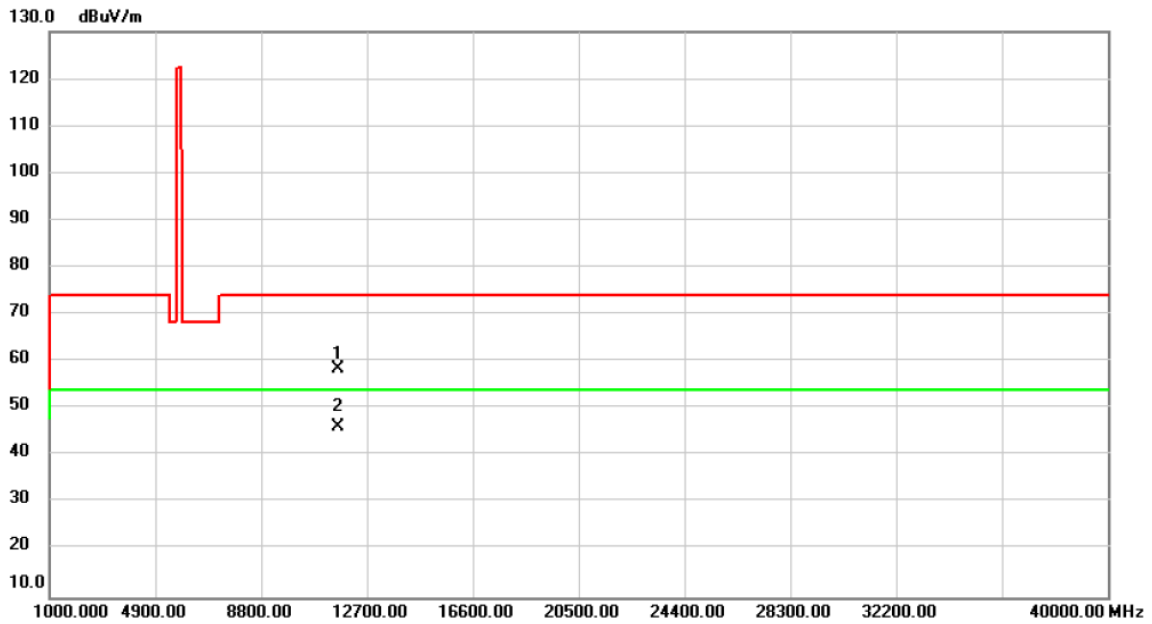

No.	Mk.	Freq.	Reading Level	Correct Factor	Measurement	Limit	Over	Detector	Comment
		MHz	dBuV	dB	dBuV/m	dBuV/m	dB		
1		11650.00	53.75	4.69	58.44	74.00	-15.56	peak	
2	*	11650.00	41.59	4.69	46.28	54.00	-7.72	AVG	

REMARKS:

- (1) Measurement Value = Reading Level + Correct Factor.
- (2) Margin Level = Measurement Value - Limit Value.

Test Mode	UNII-1_IEEE 802.11ac (VHT20)	Test Date	2020/7/27
Test Frequency	CH36: 5180 MHz	Polarization	Vertical

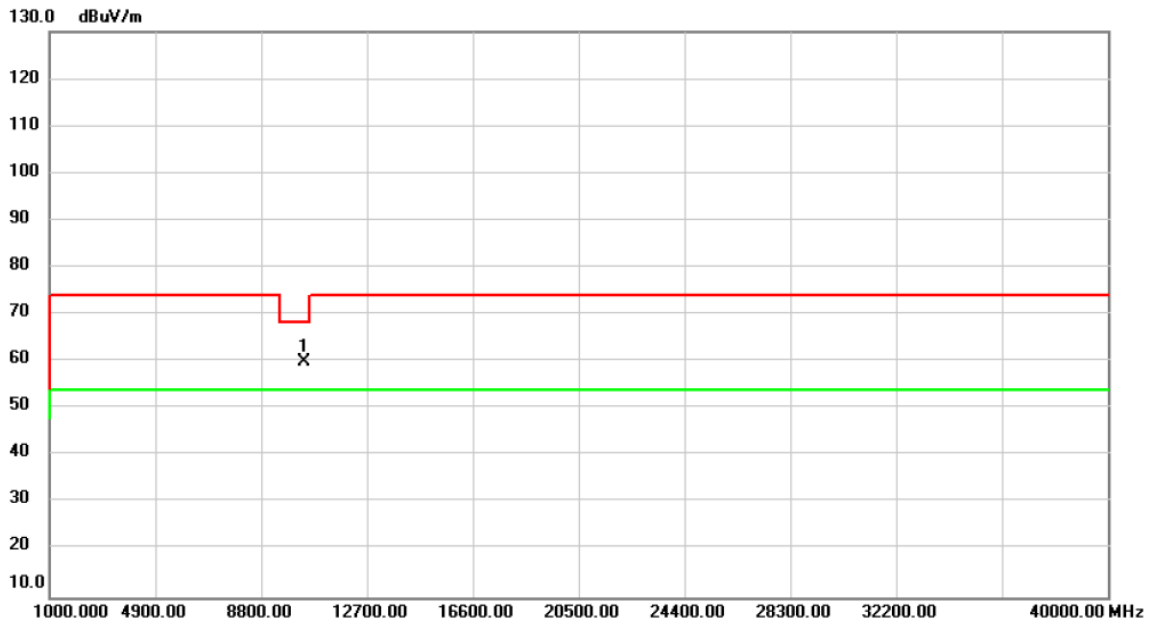

No.	Mk.	Freq.	Reading Level	Correct Factor	Measurement	Limit	Over	Detector	Comment
		MHz	dBuV	dB	dBuV/m	dBuV/m	dB		
1	*	10360.00	55.15	4.85	60.00	68.20	-8.20	peak	

REMARKS:

- (1) Measurement Value = Reading Level + Correct Factor.
- (2) Margin Level = Measurement Value - Limit Value.

Test Mode	UNII-1_IEEE 802.11ac (VHT20)	Test Date	2020/7/27
Test Frequency	CH36: 5180 MHz	Polarization	Horizontal

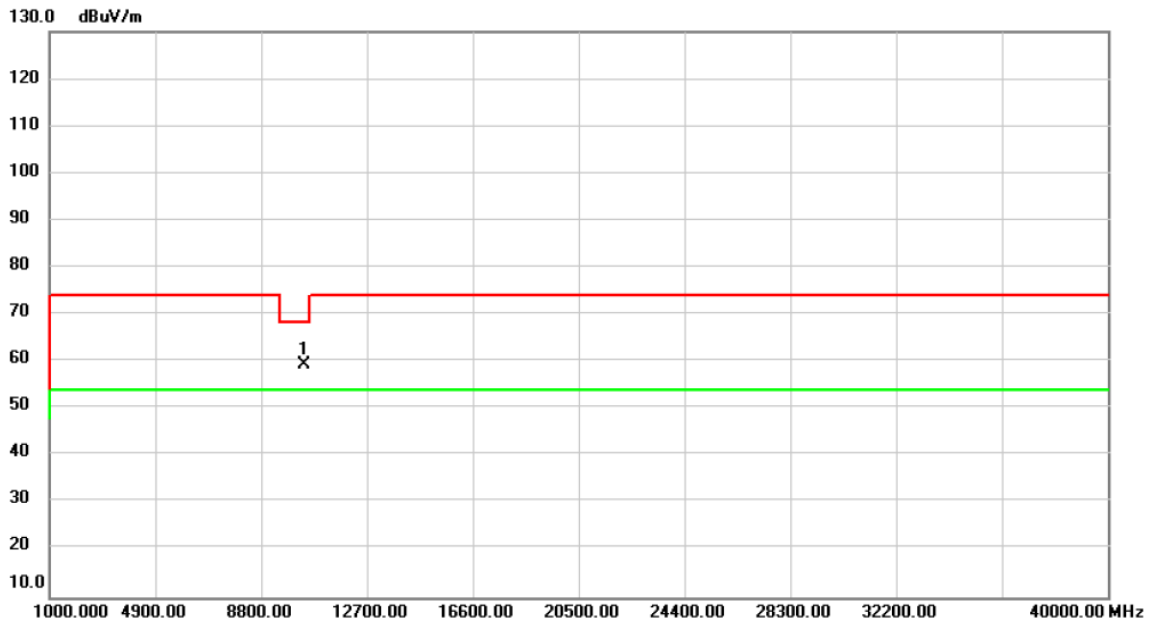

No.	Mk.	Freq.	Reading Level	Correct Factor	Measurement	Limit	Over	Detector	Comment
		MHz	dBuV	dB	dBuV/m	dBuV/m	dB		
1	*	10360.00	54.61	4.85	59.46	68.20	-8.74	peak	

REMARKS:

- (1) Measurement Value = Reading Level + Correct Factor.
- (2) Margin Level = Measurement Value - Limit Value.

Test Mode	UNII-1_IEEE 802.11ac (VHT20)	Test Date	2020/7/27
Test Frequency	CH40: 5200 MHz	Polarization	Vertical

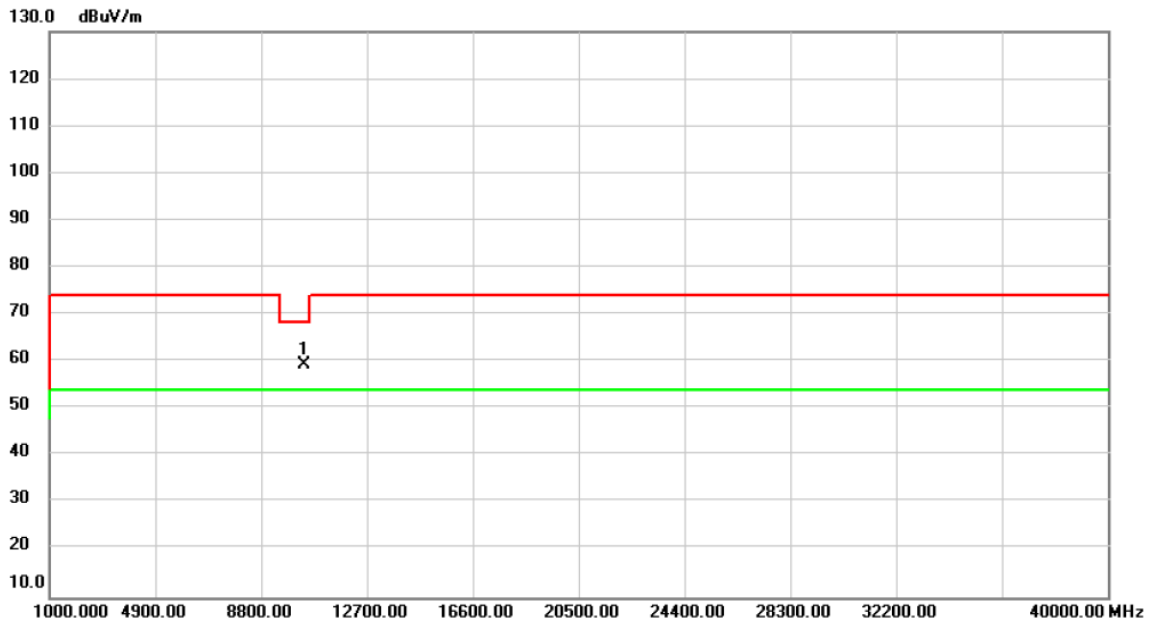

No.	Mk.	Freq.	Reading Level	Correct Factor	Measurement	Limit	Over	Detector	Comment
		MHz	dBuV	dB	dBuV/m	dBuV/m	dB		
1	*	10400.00	54.38	4.94	59.32	68.20	-8.88	peak	

REMARKS:

- (1) Measurement Value = Reading Level + Correct Factor.
- (2) Margin Level = Measurement Value - Limit Value.

Test Mode	UNII-1_IEEE 802.11ac (VHT20)	Test Date	2020/7/27
Test Frequency	CH40: 5200 MHz	Polarization	Horizontal

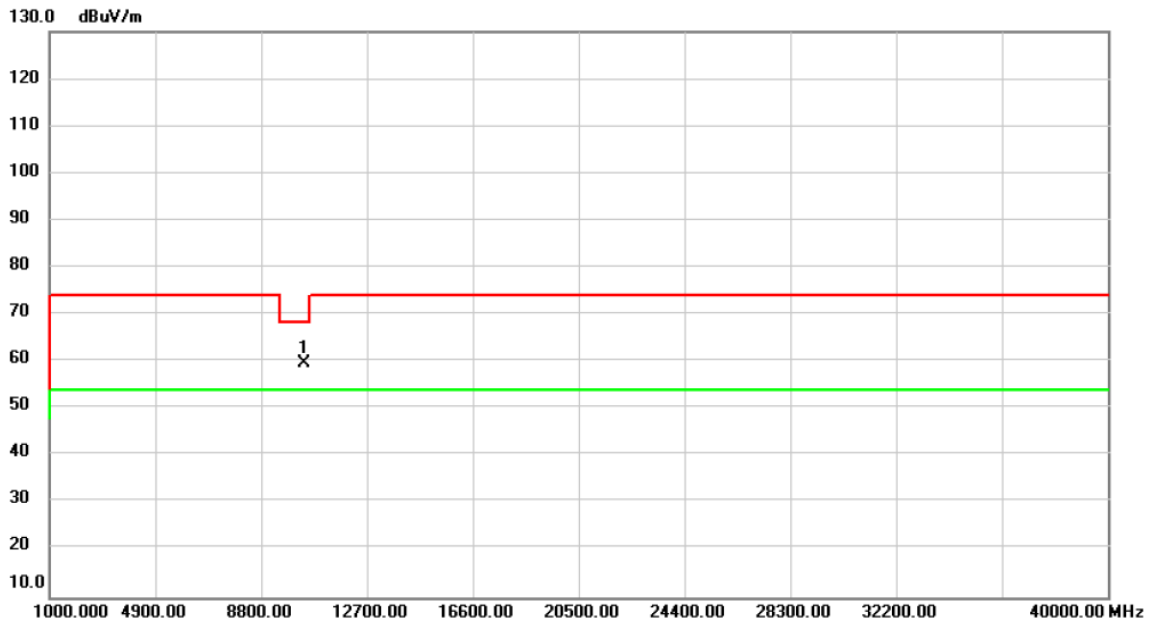

No.	Mk.	Freq.	Reading Level	Correct Factor	Measurement	Limit	Over	Detector	Comment
		MHz	dBuV	dB	dBuV/m	dBuV/m	dB		
1	*	10400.00	54.78	4.94	59.72	68.20	-8.48	peak	

REMARKS:

- (1) Measurement Value = Reading Level + Correct Factor.
- (2) Margin Level = Measurement Value - Limit Value.