

*Electromagnetic Emissions Test Report
and
Application for Grant of Equipment Authorization
pursuant to*

*Industry Canada RSS-Gen Issue 2 / RSS 210 Issue 7
FCC Part 15, Subpart E*

*Intel Corporation
Model: 512AN_MMW (MMC)*

UPN: 1000M-512ANM

FCC ID: PD9512ANM PD9LEN512ANMU
PD9512ANMU

GRANTEE: Intel Corporation
2111 N.E. 25th Ave.
Hillsboro, OR 97124

TEST SITE: Elliott Laboratories, Inc.
684 W. Maude Ave
Sunnyvale, CA 94086

REPORT DATE: April 30, 2008

REISSUE DATE: June 11, 2008

FINAL TEST DATES: March 17 to June 6, 2008

AUTHORIZED SIGNATORY:

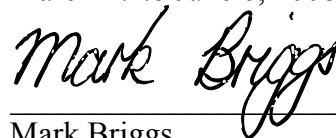

Mark Briggs
Principal Engineer



Testing Cert #2016-01

Elliott Laboratories, Inc. is accredited by the A2LA, certificate number 2016-01, to perform the test(s) listed in this report. This report shall not be reproduced, except in its entirety, without the written approval of Elliott Laboratories, Inc.

REVISION HISTORY

Rev #	Date	Comments	Modified By
1	May 5, 2008	Initial Release	David Guidotti
2	June 11, 2008	Changed Intel contact to Robert Paxman in scope section. Updated results table to evaluate user manual statements. Added UPN to the cover sheet Added test data for the Universe PIFA antenna and included this antenna in the product description section.	Briggs / Guidotti

TABLE OF CONTENTS

COVER PAGE.....1

REVISION HISTORY2

TABLE OF CONTENTS3

SCOPE.....5

OBJECTIVE.....5

STATEMENT OF COMPLIANCE.....6

TEST RESULTS SUMMARY7

 UNII / LELAN DEVICES7

 GENERAL REQUIREMENTS APPLICABLE TO ALL BANDS10

MEASUREMENT UNCERTAINTIES.....10

EQUIPMENT UNDER TEST (EUT) DETAILS.....11

 GENERAL.....11

 ANTENNA SYSTEM11

 ENCLOSURE.....11

 MODIFICATIONS.....12

 SUPPORT EQUIPMENT.....12

 EUT INTERFACE PORTS12

 EUT OPERATION.....12

TEST SITE.....13

 GENERAL INFORMATION.....13

 CONDUCTED EMISSIONS CONSIDERATIONS13

 RADIATED EMISSIONS CONSIDERATIONS13

MEASUREMENT INSTRUMENTATION14

 RECEIVER SYSTEM.....14

 INSTRUMENT CONTROL COMPUTER.....14

 LINE IMPEDANCE STABILIZATION NETWORK (LISN)14

 FILTERS/ATTENUATORS15

 ANTENNAS.....15

 ANTENNA MAST AND EQUIPMENT TURNTABLE.....15

 INSTRUMENT CALIBRATION.....15

TABLE OF CONTENTS (Continued)

TEST PROCEDURES 16

EUT AND CABLE PLACEMENT 16

CONDUCTED EMISSIONS 16

RADIATED EMISSIONS 16

RADIATED EMISSIONS 17

CONDUCTED EMISSIONS FROM ANTENNA PORT 20

BANDWIDTH MEASUREMENTS 20

SPECIFICATION LIMITS AND SAMPLE CALCULATIONS 21

GENERAL TRANSMITTER RADIATED EMISSIONS SPECIFICATION LIMITS 22

FCC 15.407 (A) OUTPUT POWER LIMITS 22

OUTPUT POWER AND SPURIOUS LIMITS –LE-LAN DEVICES 23

OUTPUT POWER AND SPURIOUS LIMITS –UNII DEVICES 23

SAMPLE CALCULATIONS - CONDUCTED EMISSIONS 24

SAMPLE CALCULATIONS - RADIATED EMISSIONS 24

SAMPLE CALCULATIONS - FIELD STRENGTH TO EIRP CONVERSION 25

EXHIBIT 1: Test Equipment Calibration Data..... 1

EXHIBIT 2: Test Measurement Data..... 2

SCOPE

An electromagnetic emissions test has been performed on the Intel Corporation model 512AN_MMW (MMC) pursuant to the following rules:

Industry Canada RSS-Gen Issue 2
RSS 210 Issue 7 “Low-power Licence-exempt Radiocommunication Devices (All Frequency Bands): Category I Equipment”
FCC Part 15, Subpart E requirements for UNII Devices (using FCC DA 02-2138, August 30, 2002)

Conducted and radiated emissions data has been collected, reduced, and analyzed within this report in accordance with measurement guidelines set forth in the following reference standards and as outlined in Elliott Laboratories test procedures:

The intentional radiator above has been tested in a simulated typical installation to demonstrate compliance with the relevant Industry Canada performance and procedural standards.

Final system data was gathered in a mode that tended to maximize emissions by varying orientation of EUT, orientation of power and I/O cabling, antenna search height, and antenna polarization.

Every practical effort was made to perform an impartial test using appropriate test equipment of known calibration. All pertinent factors have been applied to reach the determination of compliance.

The test results recorded herein are based on a single type test of the Intel Corporation model 512AN_MMW (MMC) and therefore apply only to the tested sample. The sample was selected and prepared under the authority of Robert Paxman of Intel.

OBJECTIVE

The primary objective of the manufacturer is compliance with the regulations outlined in the previous section.

Prior to marketing in the USA, all unlicensed transmitters and transceivers require certification. Receive-only devices operating between 30 MHz and 960 MHz are subject to either certification or a manufacturer's declaration of conformity, with all other receive-only devices exempt from the technical requirements.

Prior to marketing in Canada, Class I transmitters, receivers and transceivers require certification. Class II devices are required to meet the appropriate technical requirements but are exempt from certification requirements.

Certification is a procedure where the manufacturer submits test data and technical information to a certification body and receives a certificate or grant of equipment authorization upon successful completion of the certification body's review of the submitted documents. Once the equipment authorization has been obtained, the label indicating compliance must be attached to all identical units, which are subsequently manufactured.

Maintenance of compliance is the responsibility of the manufacturer. Any modification of the product which may result in increased emissions should be checked to ensure compliance has been maintained (i.e., printed circuit board layout changes, different line filter, different power supply, harnessing or I/O cable changes, etc.).

STATEMENT OF COMPLIANCE

The tested sample of Intel Corporation model 512AN_MMW (MMC) complied with the requirements of the following regulations:

RSS 210 Issue 7 "Low-power Licence-exempt Radiocommunication Devices (All Frequency Bands): Category I Equipment"
FCC Part 15, Subpart E requirements for UNII Devices

Maintenance of compliance is the responsibility of the manufacturer. Any modification of the product which may result in increased emissions should be checked to ensure compliance has been maintained (i.e., printed circuit board layout changes, different line filter, different power supply, harnessing or I/O cable changes, etc.).

TEST RESULTS SUMMARY**UNII / LELAN DEVICES****Operation in the 5.15 – 5.25 GHz Band**

FCC Rule Part	RSS Rule Part	Description	Measured Value / Comments	Limit / Requirement	Result
15.407(e)		Indoor operation only	Intended for use in indoor devices only	May only be designed for indoor use	Complies
15.407(a)(1)	A9.2(1)	Output Power	a: 13.7dBm n20: 14.4 dBm n40: 13.7 (0.028 W)	17 dBm	Complies
15.407(a)(2)		Power Spectral Density 802.11a Mode	1.1 dBm/MHz	4 dBm/MHz	Complies
	A9.2(2) / A9.5 (2)			5 dBm / MHz	Complies
15.407(a)(2)		Power Spectral Density 802.11n20 Mode	1.6 dBm/MHz	4 dBm/MHz	Complies
	A9.2(2) / A9.5 (2)			5 dBm / MHz	Complies
15.407(a)(2)		Power Spectral Density 802.11n40 Mode	-1.3 dBm/MHz	4 dBm/MHz	Complies
	A9.2(2) / A9.5 (2)			5 dBm / MHz	Complies

Operation in the 5.25 – 5.35 GHz Band

Note: The device is restricted to indoor use only, therefore the spectral density of spurious emissions in the 5.15 – 5.25 GHz band were limited to the power spectral limits for intentional signals detailed in FCC 15.407(a)(1) and RSS 210 6.2.2 q1 (i)

FCC Rule Part	RSS Rule Part	Description	Measured Value / Comments	Limit / Requirement	Result (margin)
15.407(a)(2)	A9.2(2)	Output Power	a: 13.4 dBm n20: 13.6dBm n40: 13.9dBm (0.025 W)	24 dBm	Complies
15.407(a)(2)		Power Spectral Density 802.11a Mode	0.7 dBm/MHz	11 dBm/MHz	Complies
	A9.2(2) / A9.5 (2)			11 dBm / MHz	Complies
15.407(a)(2)		Power Spectral Density 802.11n20 Mode	0.8 dBm/MHz	11 dBm/MHz	Complies
	A9.2(2) / A9.5 (2)			11 dBm / MHz	Complies
15.407(a)(2)		Power Spectral Density 802.11n40 Mode	-1.2 dBm/MHz	11 dBm/MHz	Complies
	A9.2(2) / A9.5 (2)			11 dBm/MHz	Complies

Operation in the 5.47 – 5.725 GHz Band

FCC Rule Part	RSS Rule Part	Description	Measured Value / Comments	Limit / Requirement	Result (margin)
15.407(a) (2)	A9.2(2)	Output Power	a: 16.5 dBm n20: 17.3dBm n40: 13.9dBm (0.054 W)	24 dBm / 250mW (eirp < 30dBm)	Complies
15.407(a) (2))		Power Spectral Density 802.11a Mode	3.9 dBm/MHz	11 dBm/MHz	Complies
	A9.2(2) / A9.5 (2)			11 dBm / MHz	Complies
15.407(a) (2))		Power Spectral Density 802.11n20 Mode	4.4 dBm/MHz	11 dBm/MHz	Complies
	A9.2(2) / A9.5 (2)			11 dBm/MHz	Complies
15.407(a) (2))		Power Spectral Density 802.11n40 Mode	-1.5 dBm/MHz	11 dBm/MHz	Complies
	A9.2(2) / A9.5 (2)			11 dBm/MHz	Complies
N/A	??	Non-operation in 5600 – 5650 MHz sub band	Device cannot operate in the 5600 – 5650 MHz band –refer to Operational Description		Complies

General requirements for all U-NII/LELAN bands

FCC Rule Part	RSS Rule Part	Description	Measured Value / Comments	Limit / Requirement	Result
	A9.5a	Modulation	Digital Modulation is used in all modes	Digital modulation is required	Complies
	RSP 100	99% bandwidth	a: 17.1 MHz n20: 18.4 MHz n40: 36.4 MHz	Information only	N/A
15.407(b) (5) / 15.209	A9.3	Spurious Emissions below 1GHz	43.4dB μ V/m @ 108.287MHz ¹	Refer to limits section	Complies (-0.1dB)
15.407(b) (2)	A9.3	Spurious Emissions above 1GHz	52.9dB μ V/m @ 5459.9MHz	15.207 in restricted bands, all others <-27dBm eirp	Complies (-1.1dB)
15.407(a) (6)	-	Peak Excursion Ratio	12.4dB (802.11n 40MHz mode)	< 13dB	Complies
	A9.5 (3)	Channel Selection	Spurious emissions tested at outermost channels in each band	Device was tested on the top, bottom and center channels in each of the three bands band	N/A
15.			Measurements on three channels in each band		N/A
15.407 (c)	A9.5(4)	Operation in the absence of information to transmit	Operation is discontinued in the absence of information	Device shall automatically discontinue operation in the absence of information to transmit	Complies
15.407 (g)	A9.5 (5)	Frequency Stability	Frequency stability is better than 10ppm		Complies
15.407 (h1)	A9.4	Transmit Power Control	TPC is not required as the highest eirp is 22.3dBm	The U-NII device shall have the capability to operate with a mean EIRP value lower than 24dBm (250mW)	Complies
15.407 (h2)	A9.4	Dynamic frequency Selection (device without radar detection)	DFS evaluation covered in a separate test report (Elliott R71319)	Channel move time < 10s Channel closing transmission time < 260ms	Refer to Elliott R71319

¹ Spurious emissions below 1GHz were independent of operating channel and operating mode (transmit versus receive). Measurements for radiated emissions below 1GHz cover both receive and transmit modes.

GENERAL REQUIREMENTS APPLICABLE TO ALL BANDS

FCC Rule Part	RSS Rule part	Description	Measured Value / Comments	Limit / Requirement	Result (margin)
15.203	-	RF Connector	Module uses a unique connector	Unique connector	Complies
15.109	RSS GEN 7.2.3	Receiver spurious emissions	43.4dB μ V/m @ 108.287MHz ¹	RSS GEN Table 1	Complies
15.207	RSS GEN Table 2	AC Conducted Emissions	21.4dB μ V @ 24.000MHz	Refer to standard	Complies (-28.6dB)
15.247 (b) (5) 15.407 (f)	RSS 102	RF Exposure Requirements	Refer to MPE calculations in Exhibit 11, RSS 102 declaration and User Manual statements.	Refer to OET 65, FCC Part 1 and RSS 102	Complies
	RSP 100 RSS GEN 7.1.5	User Manual	Not evaluated at this time	Statement required regarding non-interference	-
	RSP 100 RSS GEN 7.1.5	User Manual	Not applicable, module will be used in host systems that use integral, non-detachable antennas	Statement required regarding detachable antenna	N/A

MEASUREMENT UNCERTAINTIES

ISO/IEC 17025 requires that an estimate of the measurement uncertainties associated with the emissions test results be included in the report. The measurement uncertainties given below are based on a 95% confidence level and were calculated in accordance with UKAS document LAB 34.

Measurement Type	Frequency Range (MHz)	Calculated Uncertainty (dB)
Conducted Emissions	0.15 to 30	± 2.4
Radiated Emissions	0.015 to 30	± 3.0
Radiated Emissions	30 to 1000	± 3.6
Radiated Emissions	1000 to 40000	± 6.0

¹ Spurious emissions below 1GHz were independent of operating channel and operating mode (transmit versus receive) and dominated by emissions from the test fixture. The highest emission above 1GHz in receive mode was 51.4dB μ V/m @ 3000.3MHz (2.6dB below the limit).

EQUIPMENT UNDER TEST (EUT) DETAILS**GENERAL**

The Intel Corporation model 512AN_MMW is a 2x1 MISO 802.11abgn radio module that is designed to be installed in laptops. The module supports 802.11b, 802.11g and 802.11n protocols in the 2400 – 2483.5 MHz band and 802.11a and 802.11n in the 5150 – 5250 MHz, 5250 – 5350 MHz, 5470 – 5725 MHz and 5725 – 5850 MHz bands. In 802.11n mode it supports both 20-MHz and 40-MHz channels. It can operate in SISO (1x1) and MISO (2x1) configurations.

For testing purposes, and in accordance with requirements for evaluating a device for modular approvals, the EUT was installed onto an extender card that was connected into a PC. The EUT was outside of the PC's enclosure. The electrical rating of the EUT is 3.3 Volts DC, 0.5 Amps.

The sample was received on March 14, 2008, configured with the Ethertronics magnetic dipole antenna and tested on March 14, March 17, March 18, March 24, April 8, April 10, April 11, April 14, April 16 and April 21, 2008. Additional testing was performed on June 1, June 2, June 3, June 4 and June 6, 2008 with the device configured with the Universe PIFA antenna.

The EUT consisted of the following component(s):

Manufacturer	Model	Description	Serial Number	FCC ID
Intel Corporation	512AN_MMW	802.11abgn 1x2 MISO module	-	PD9512ANH

ANTENNA SYSTEM

The antenna connects to the EUT via a non-standard U.FL antenna connector, thereby meeting the requirements of FCC 15.203. The EUT was evaluated with each transceiver chain connected to the following antennas:

- Ethertronics MPCI-8 Module antenna which is based on a magnetic dipole design. The nominal antenna gain is 3dBi in the 2.4GHz band and 5dBi in the 5GHz bands
- Universe Technology antenna which is based on a PIFA design. The nominal antenna gain is 3.2 dBi in the 2.4GHz band, 3.6dBi in the 5150-5250 MHz band, 3.7dBi in 5250-5350MHz band, 4.8dBi in the 5470 – 5725 MHz band and 5dBi in the 5725 – 5850MHz band.

ENCLOSURE

The EUT does not have an enclosure as it is designed to be installed within the enclosure of a host computer or system.

MODIFICATIONS

The EUT did not require modifications during testing in order to comply with emissions specifications.

SUPPORT EQUIPMENT

The following equipment was used as local support equipment for emissions testing:

Manufacturer	Model	Description	Serial Number	FCC ID
Dell	-	Laptop PC	Prototype	-

No remote support equipment was used during emissions testing.

EUT INTERFACE PORTS

The I/O cabling configuration during emissions testing was as follows:

Port	Connected To	Cable(s)		
		Description	Shielded or Unshielded	Length(m)
DC power port	DC power source	Multi connect	Unshielded	0.3
PCI Extender	Laptop	Multi connect	Unshielded	0.3
Antenna port 1	Antenna	u.FL	Shielded	0.2
Antenna port 2	Antenna	u.FL	Shielded	0.2

EUT OPERATION

During transmitter-related testing the EUT was configured to transmit continuously in each of the various modulation modes (802.11a, 802.11b, 802.11g and 802.11n). Preliminary testing determined the data rates with the highest power and power spectral density to be evaluated for the formal testing, as detailed in the table below.

Mode	Active Chains	1 Chain	2 Chains
	802.11b		1Mb/s
802.11g		6 MBs	
802.11n (20MHz channel)		HT 0 (6Mbps)	
802.11n (40MHz channel)		HT 0 (15Mbps)	

Spurious receiver emissions were measured with the device tuned to the center channel in each operating band. Measurements were made on both single chain modes (SISO modes with one, then the other chain active) and in MISO mode (with both chains active simultaneously).

TEST SITE

GENERAL INFORMATION

Final test measurements were taken on March 17, March 19, March 20, March 21, March 24, April 9, April 10 and April 14, May 31, June 1, June 2, June 3, June 4 and June 6, 2008 at the Elliott Laboratories semi anechoic Chamber 3, 4 and 5 located at 41039 Boyce Road, Fremont, California Pursuant to section 2.948 of the FCC's Rules and section 3.3 of RSP-100, construction, calibration, and equipment data has been filed with the Commission.

ANSI C63.4:2003 recommends that ambient noise at the test site be at least 6 dB below the allowable limits. Ambient levels are below this requirement with the exception of predictable local TV, radio, and mobile communications traffic. The test site contains separate areas for radiated and conducted emissions testing. Considerable engineering effort has been expended to ensure that the facilities conform to all pertinent requirements of ANSI C63.4:2003.

CONDUCTED EMISSIONS CONSIDERATIONS

Conducted emissions testing is performed in conformance with ANSI C63.4:2003. Measurements are made with the EUT connected to the public power network through a nominal, standardized RF impedance, which is provided by a line impedance stabilization network, known as a LISN. A LISN is inserted in series with each current-carrying conductor in the EUT power cord.

RADIATED EMISSIONS CONSIDERATIONS

The FCC has determined that radiation measurements made in a shielded enclosure are not suitable for determining levels of radiated emissions. Radiated measurements are performed in an open field environment or in a semi-anechoic chamber. The test sites are maintained free of conductive objects within the CISPR defined elliptical area incorporated in ANSI C63.4:2003 guidelines and meet the Normalized Site Attenuation (NSA) requirements of ANSI C63.4:2003.

MEASUREMENT INSTRUMENTATION

RECEIVER SYSTEM

An EMI receiver as specified in CISPR 16-1 is used for emissions measurements. The receivers used can measure over the frequency range of 9 kHz up to 2000 MHz. These receivers allow both ease of measurement and high accuracy to be achieved. The receivers have Peak, Average, and CISPR (Quasi-peak) detectors built into their design so no external adapters are necessary. The receiver automatically sets the required bandwidth for the CISPR detector used during measurements. If the repetition frequency of the signal being measured is below 20Hz, peak measurements are made in lieu of Quasi-Peak measurements.

For measurements above the frequency range of the receivers, a spectrum analyzer is utilized because it provides visibility of the entire spectrum along with the precision and versatility required to support engineering analysis. Average measurements above 1000MHz are performed on the spectrum analyzer using the linear-average method with a resolution bandwidth of 1 MHz and a video bandwidth of 10 Hz, unless the signal is pulsed in which case the average (or video) bandwidth of the measuring instrument is reduced to onset of pulse desensitization and then increased.

INSTRUMENT CONTROL COMPUTER

The receivers utilize either a Rohde & Schwarz EZM Spectrum Monitor/Controller or contain an internal Spectrum Monitor/Controller to view and convert the receiver measurements to the field strength at an antenna or voltage developed at the LISN measurement port, which is then compared directly with the appropriate specification limit. This provides faster, more accurate readings by performing the conversions described under Sample Calculations within the Test Procedures section of this report. Results are printed in a graphic and/or tabular format, as appropriate. A personal computer is used to record all measurements made with the receivers.

The Spectrum Monitor provides a visual display of the signal being measured. In addition, the controller or a personal computer run automated data collection programs which control the receivers. This provides added accuracy since all site correction factors, such as cable loss and antenna factors are added automatically.

LINE IMPEDANCE STABILIZATION NETWORK (LISN)

Line conducted measurements utilize a fifty microhenry Line Impedance Stabilization Network as the monitoring point. The LISN used also contains a 250 uH CISPR adapter. This network provides for calibrated radio frequency noise measurements by the design of the internal low pass and high pass filters on the EUT and measurement ports, respectively.

FILTERS/ATTENUATORS

External filters and precision attenuators are often connected between the receiving antenna or LISN and the receiver. This eliminates saturation effects and non-linear operation due to high amplitude transient events.

ANTENNAS

A loop antenna is used below 30 MHz. For the measurement range 30 MHz to 1000 MHz either a combination of a biconical antenna and a log periodic or a bi-log antenna is used. Above 1000 MHz, horn antennas are used. The antenna calibration factors to convert the received voltage to an electric field strength are included with appropriate cable loss and amplifier gain factors to determine an overall site factor, which is then programmed into the test receivers or incorporated into the test software.

ANTENNA MAST AND EQUIPMENT TURNTABLE

The antennas used to measure the radiated electric field strength are mounted on a non-conductive antenna mast equipped with a motor-drive to vary the antenna height. Measurements below 30 MHz are made with the loop antenna at a fixed height of 1m above the ground plane.

ANSI C63.4:2003 specifies that the test height above ground for table mounted devices shall be 80 centimeters. Floor mounted equipment shall be placed on the ground plane if the device is normally used on a conductive floor or separated from the ground plane by insulating material from 3 to 12 mm if the device is normally used on a non-conductive floor. During radiated measurements, the EUT is positioned on a motorized turntable in conformance with this requirement.

INSTRUMENT CALIBRATION

All test equipment is regularly checked to ensure that performance is maintained in accordance with the manufacturer's specifications. All antennas are calibrated at regular intervals with respect to tuned half-wave dipoles. An exhibit of this report contains the list of test equipment used and calibration information.

TEST PROCEDURES

EUT AND CABLE PLACEMENT

The regulations require that interconnecting cables be connected to the available ports of the unit and that the placement of the unit and the attached cables simulate the worst case orientation that can be expected from a typical installation, so far as practicable. To this end, the position of the unit and associated cabling is varied within the guidelines of ANSI C63.4:2003, and the worst-case orientation is used for final measurements.

CONDUCTED EMISSIONS

Conducted emissions are measured at the plug end of the power cord supplied with the EUT. Excess power cord length is wrapped in a bundle between 30 and 40 centimeters in length near the center of the cord. Preliminary measurements are made to determine the highest amplitude emission relative to the specification limit for all the modes of operation. Placement of system components and varying of cable positions are performed in each mode. A final peak mode scan is then performed in the position and mode for which the highest emission was noted on all current carrying conductors of the power cord.

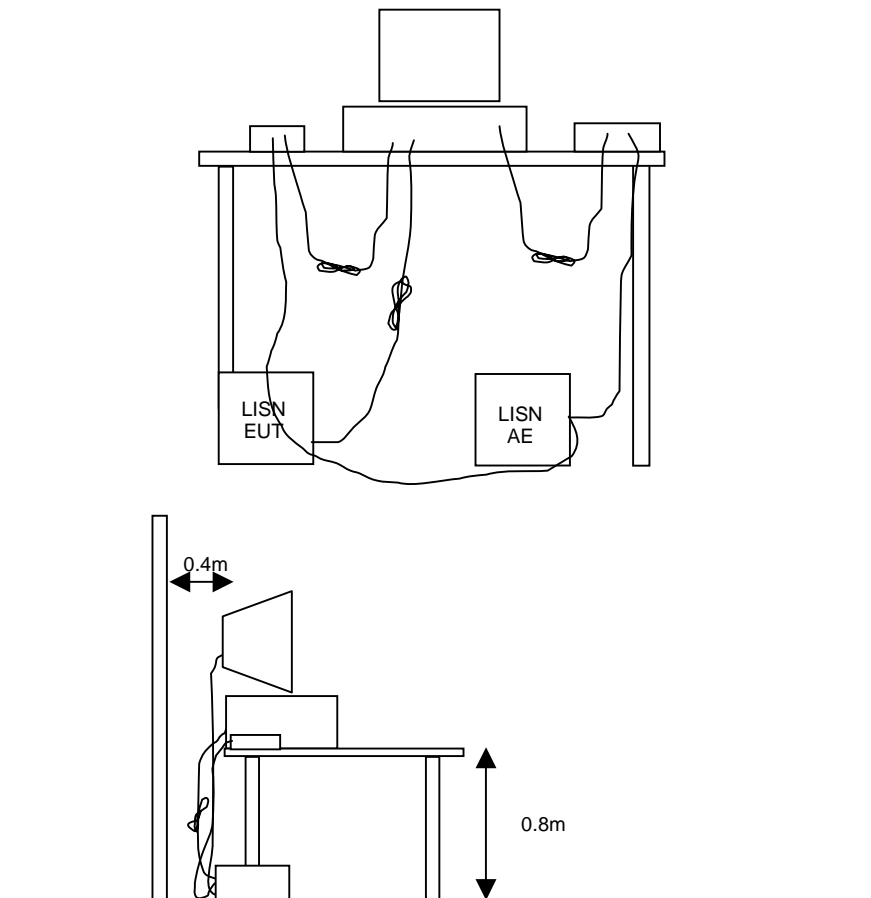

RADIATED EMISSIONS

A preliminary scan of the radiated emissions is performed in which all significant EUT frequencies are identified with the system in a nominal configuration. At least two scans are performed, one scan for each antenna polarization (horizontal and vertical; loop parallel and perpendicular to the EUT). During the preliminary scans, the EUT is rotated through 360°, the antenna height is varied (for measurements above 30 MHz) and cable positions are varied to determine the highest emission relative to the limit. Preliminary scans may be performed in a fully anechoic chamber for the purposes of identifying the frequencies of the highest emissions from the EUT.

A speaker is provided in the receiver to aid in discriminating between EUT and ambient emissions. Other methods used during the preliminary scan for EUT emissions involve scanning with near field magnetic loops, monitoring I/O cables with RF current clamps, and cycling power to the EUT.

Final maximization is a phase in which the highest amplitude emissions identified in the spectral search are viewed while the EUT azimuth angle is varied from 0 to 360 degrees relative to the receiving antenna. The azimuth, which results in the highest emission is then maintained while varying the antenna height from one to four meters (for measurements above 30 MHz, measurements below 30 MHz are made with the loop antenna at a fixed height of 1m). The result is the identification of the highest amplitude for each of the highest peaks. Each recorded level is corrected in the receiver using appropriate factors for cables, connectors, antennas, and preamplifier gain.

When testing above 18 GHz, the receive antenna is located at 1meter from the EUT and the antenna height is restricted to a maximum of 2.5 meters.

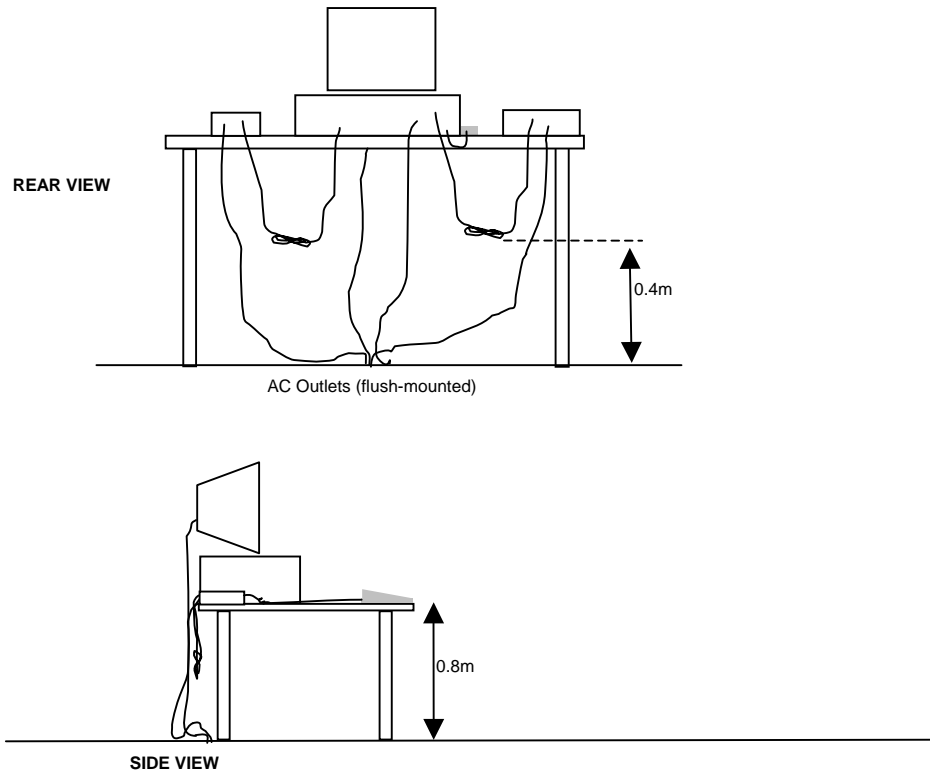

Typical Test Configuration for Radiated Field Strength Measurements

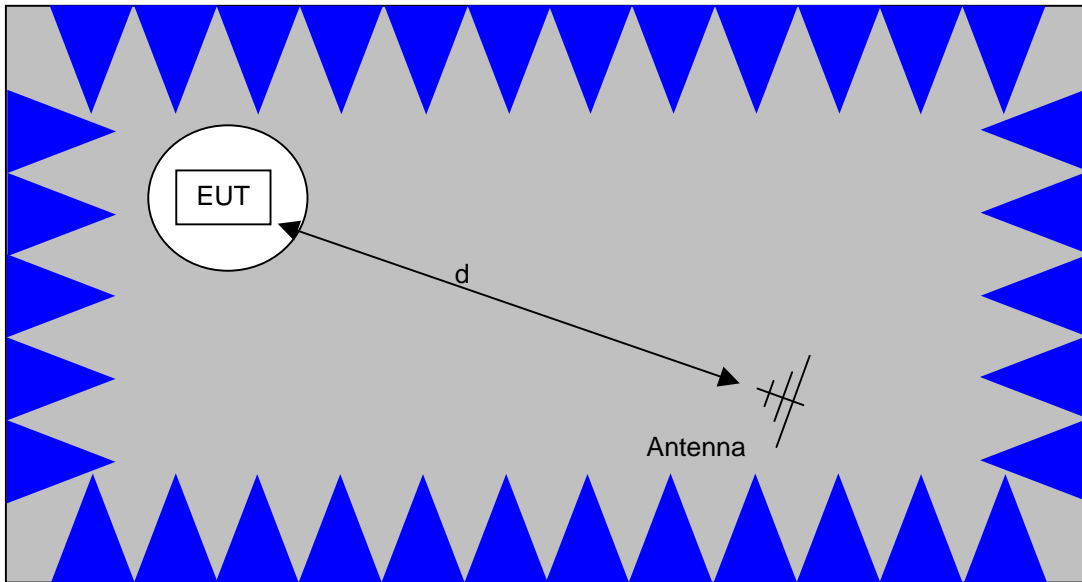

The anechoic materials on the walls and ceiling ensure compliance with the normalized site attenuation requirements of CISPR 16 / CISPR 22 / ANSI C63.4 for an alternate test site at the measurement distances used.

Floor-standing equipment is placed on the floor with insulating supports between the unit and the ground plane.

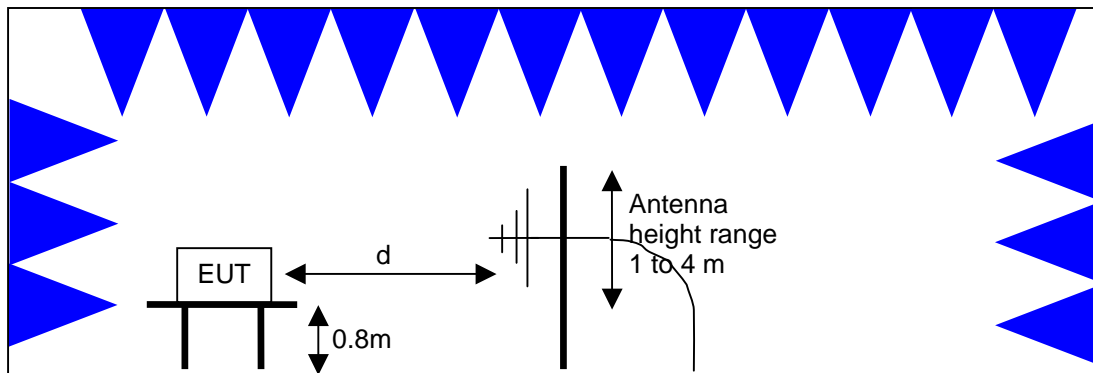

Test Configuration for Radiated Field Strength Measurements
Semi-Anechoic Chamber, Plan and Side Views

CONDUCTED EMISSIONS FROM ANTENNA PORT

Direct measurements of power, bandwidth and power spectral density are performed, where possible, with the antenna port of the EUT connected to either the power meter or spectrum analyzer via a suitable attenuator and/or filter. These are used to ensure that the front end of the measurement instrument is not overloaded by the fundamental transmission.

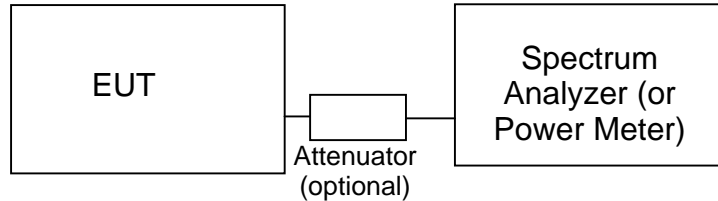

Test Configuration for Antenna Port Measurements

Measurement bandwidths (video and resolution) are set in accordance with the relevant standards and Elliott's test procedures for the type of radio being tested. When power measurements are made using a resolution bandwidth less than the signal bandwidth the power is calculated by summing the power across the signal bandwidth using either the analyzer channel power function or by capturing the trace data and calculating the power using software. In both cases the summed power is corrected to account for the equivalent noise bandwidth (ENBW) of the resolution bandwidth used.

If power averaging is used (typically for certain digital modulation techniques), the EUT is configured to transmit continuously. Power averaging is performed using either the built-in function of the analyzer or, if the analyzer does not feature power averaging, using external software. In both cases the average power is calculated over a number of sweeps (typically 100). When the EUT cannot be configured to continuously transmit then either the analyzer is configured to perform a gated sweep to ensure that the power is averaged over periods that the device is transmitting or power averaging is disabled and a max-hold feature is used.

If a power meter is used to make output power measurements the sensor head type (peak or average) is stated in the test data table.

BANDWIDTH MEASUREMENTS

The 6dB, 20dB and/or 26dB signal bandwidth is measured in using the bandwidths recommended by ANSI C63.4. When required, the 99% bandwidth is measured using the methods detailed in RSS GEN.

SPECIFICATION LIMITS AND SAMPLE CALCULATIONS

The limits for conducted emissions are given in units of microvolts, and the limits for radiated emissions are given in units of microvolts per meter at a specified test distance. Data is measured in the logarithmic form of decibels relative to one microvolt, or dB microvolts (dBuV). For radiated emissions, the measured data is converted to the field strength at the antenna in dB microvolts per meter (dBuV/m). The results are then converted to the linear forms of uV and uV/m for comparison to published specifications.

For reference, converting the specification limits from linear to decibel form is accomplished by taking the base ten logarithm, then multiplying by 20. These limits in both linear and logarithmic form are as follows:

GENERAL TRANSMITTER RADIATED EMISSIONS SPECIFICATION LIMITS

The table below shows the limits for the spurious emissions from transmitters that fall in restricted bands¹ (with the exception of transmitters operating under FCC Part 15 Subpart D and RSS 210 Annex 9), the limits for all emissions from a low power device operating under the general rules of RSS 310 (tables 3 and 4), RSS 210 (table 2) and FCC Part 15 Subpart C section 15.209.

Frequency Range (MHz)	Limit (uV/m)	Limit (dBuV/m @ 3m)
0.009-0.490	2400/F _{KHz} @ 300m	67.6-20*log ₁₀ (F _{KHz}) @ 300m
0.490-1.705	24000/F _{KHz} @ 30m	87.6-20*log ₁₀ (F _{KHz}) @ 30m
1.705 to 30	30 @ 30m	29.5 @ 30m
30 to 88	100 @ 3m	40 @ 3m
88 to 216	150 @ 3m	43.5 @ 3m
216 to 960	200 @ 3m	46.0 @ 3m
Above 960	500 @ 3m	54.0 @ 3m

FCC 15.407 (a) OUTPUT POWER LIMITS

The table below shows the limits for output power and output power density. Where the signal bandwidth is less than 20 MHz the maximum output power is reduced to the power spectral density limit plus 10 times the log of the bandwidth (in MHz).

Operating Frequency (MHz)	Output Power	Power Spectral Density
5150 - 5250	50mW (17 dBm)	4 dBm/MHz
5250 - 5350	250 mW (24 dBm)	11 dBm/MHz
5725 – 5825	1 Watts (30 dBm)	17 dBm/MHz

For system using antennas with gains exceeding 6dBi, the output power and power spectral density limits are reduced by 1dB for every dB the antenna gain exceeds 6dBi. Fixed point-to-point applications using the 5725 – 5825 MHz band may use antennas with gains of up to 23dBi without this limitation. If the gain exceeds 23dBi then the output power limit of 1 Watt is reduced by 1dB for every dB the gain exceeds 23dBi.

¹ The restricted bands are detailed in FCC 15.203, RSS 210 Table 1 and RSS 310 Table 2

OUTPUT POWER AND SPURIOUS LIMITS –LE-LAN DEVICES

The table below shows the limits for output power and output power density defined by RSS 210. Where the signal bandwidth is less than 20 MHz the maximum output power is reduced to the power spectral density limit plus 10 times the log of the bandwidth (in MHz).

Operating Frequency (MHz)	Output Power	Power Spectral Density
5150 - 5250	200mW (23 dBm) eirp	10 dBm/MHz eirp
5250 - 5350	250 mW (24 dBm) ¹ 1W (30dBm) eirp	11 dBm/MHz
5470 - 5725	250 mW (24 dBm) ² 1W (30dBm) eirp	11 dBm/MHz
5725 – 5825	1 Watts (30 dBm) 4W eirp	17 dBm/MHz

In addition, the power spectral density limit shall be reduced by 1dB for every dB the highest power spectral density exceeds the “average” power spectral density, determined by dividing the output power by $10\log(99\% \text{ bandwidth})$, by more than 3dB.

Fixed point-to-point applications using the 5725 – 5825 MHz band may use antennas with gains of up to 23dBi without this limitation. If the gain exceeds 23dBi then the output power limit of 1 Watt is reduced by 1dB for every dB the gain exceeds 23dBi.

OUTPUT POWER AND SPURIOUS LIMITS –UNII DEVICES

The table below shows the limits for output power and output power density defined by FCC Part 15 Subpart E. Where the signal bandwidth is less than 20 MHz the maximum output power is reduced to the power spectral density limit plus 10 times the log of the bandwidth (in MHz).

Operating Frequency (MHz)	Output Power	Power Spectral Density
5150 - 5250	50mW (17 dBm)	10 dBm/MHz
5250 - 5350	250 mW (24 dBm)	11 dBm/MHz
5470 - 5725	250 mW (24 dBm)	11 dBm/MHz
5725 – 5825	1 Watts (30 dBm)	17 dBm/MHz

The peak excursion envelope is limited to 13dB.

For system using antennas with gains exceeding 6dBi, the output power and power spectral density limits are reduced by 1dB for every dB the antenna gain exceeds 6dBi. Fixed point-to-point applications using the 5725 – 5825 MHz band may use antennas with gains of up to 23dBi without this limitation. If the gain exceeds 23dBi then the output power limit of 1 Watt is reduced by 1dB for every dB the gain exceeds 23dBi.

¹ If EIRP exceeds 500mW the device must employ TPC

² If EIRP exceeds 500mW the device must employ TPC

SAMPLE CALCULATIONS - CONDUCTED EMISSIONS

Receiver readings are compared directly to the conducted emissions specification limit (decibel form) as follows:

$$R_T - S = M$$

where:

R_T = Receiver Reading in dBuV

S = Specification Limit in dBuV

M = Margin to Specification in +/- dB

SAMPLE CALCULATIONS - RADIATED EMISSIONS

Receiver readings are compared directly to the specification limit (decibel form). The receiver internally corrects for cable loss, preamplifier gain, and antenna factor. The calculations are in the reverse direction of the actual signal flow, thus cable loss is added and the amplifier gain is subtracted. The Antenna Factor converts the voltage at the antenna coaxial connector to the field strength at the antenna elements.

A distance factor, when used for electric field measurements above 30MHz, is calculated by using the following formula:

$$F_d = 20 * \text{LOG}_{10} (D_m/D_s)$$

where:

F_d = Distance Factor in dB

D_m = Measurement Distance in meters

D_s = Specification Distance in meters

For electric field measurements below 30MHz the extrapolation factor is either determined by making measurements at multiple distances or a theoretical value is calculated using the formula:

$$F_d = 40 * \text{LOG}_{10} (D_m/D_s)$$

Measurement Distance is the distance at which the measurements were taken and Specification Distance is the distance at which the specification limits are based. The antenna factor converts the voltage at the antenna coaxial connector to the field strength at the antenna elements.

The margin of a given emission peak relative to the limit is calculated as follows:

$$R_C = R_R + F_d$$

and

$$M = R_C - L_S$$

where:

$$R_R = \text{Receiver Reading in dBuV/m}$$

$$F_d = \text{Distance Factor in dB}$$

$$R_C = \text{Corrected Reading in dBuV/m}$$

$$L_S = \text{Specification Limit in dBuV/m}$$

$$M = \text{Margin in dB Relative to Spec}$$

SAMPLE CALCULATIONS - FIELD STRENGTH TO EIRP CONVERSION

Where the radiated electric field strength is expressed in terms of the equivalent isotropic radiated power (eirp), or where a field strength measurement of output power is made in lieu of a direct measurement, the following formula is used to convert between eirp and field strength at a distance of 3m from the equipment under test:

$$E = \frac{1000000 \sqrt{30 P}}{3} \text{ microvolts per meter}$$

where P is the eirp (Watts)

EXHIBIT 1: Test Equipment Calibration Data

3 Pages

Radiated Emissions, 1000 - 40,000 MHz**Engineer: bjing**

<u>Manufacturer</u>	<u>Description</u>	<u>Model #</u>	<u>Asset #</u>	<u>Cal Due</u>
Hewlett Packard	Microwave Preamplifier, 1-26.5GHz	8449B	263	16-May-08
Hewlett Packard	Microwave Preamplifier, 1-26.5GHz	8449B	785	29-May-08
EMCO	Antenna, Horn, 1-18 GHz (SA40-Red)	3115	1142	07-Jun-08
EMCO	Antenna, Horn, 1-18 GHz (SA40-Blu)	3115	1386	11-Jul-08
Hewlett Packard	Spectrum Analyzer 9 kHz - 40 GHz, FT (SA40) Blue	8564E (84125C)	1393	15-Jan-09
EMCO	Antenna, Horn, 1-18 GHz	3115	1561	10-May-08
Hewlett Packard	SpecAn 9 kHz - 40 GHz, (SA40) Purple	8564E (84125C)	1771	17-Dec-08
Hewlett Packard	Head (Inc W1-W4, 1946, 1947) Purple	84125C	1772	20-Dec-08
EMCO	Antenna, Horn, 18-26.5 GHz (SA40-Purple)	3160-09 (84125C)	1773	19-Dec-08
EMCO	Antenna, Horn, 26.5-40 GHz (SA40-Purple)	3160-10 (84125C)	1774	19-Dec-08
Hewlett Packard	Microwave Preamplifier, 1-26.5GHz	8449B	1780	06-Nov-08

Conducted Emissions - AC Power Ports, 21-Apr-08**Engineer: Peter Sales**

<u>Manufacturer</u>	<u>Description</u>	<u>Model #</u>	<u>Asset #</u>	<u>Cal Due</u>
EMCO	LISN, 10 kHz-100 MHz	3825/2	1292	22-Feb-09
EMCO	LISN, 10 kHz-100 MHz	3825/2	1293	15-Feb-09
Rohde & Schwarz	Pulse Limiter	ESH3 Z2	1593	11-May-08
Rohde & Schwarz	EMI Test Receiver, 20 Hz-7 GHz	ESIB7	1756	04-Dec-08

Radiated Emissions, 30 - 1,000 MHz, 21-Apr-08**Engineer: Peter Sales**

<u>Manufacturer</u>	<u>Description</u>	<u>Model #</u>	<u>Asset #</u>	<u>Cal Due</u>
Com-Power Corp.	Preamplifier, 30-1000 MHz	PA-103	1543	12-Nov-08
Sunol Sciences	Biconilog, 30-3000 MHz	JB3	1549	23-May-09
Rohde & Schwarz	EMI Test Receiver, 20 Hz-7 GHz	ESIB7	1756	04-Dec-08

Radiated Emissions, 802 11a Band-edge, 31-May-08**Engineer: Ben Jing**

<u>Manufacturer</u>	<u>Description</u>	<u>Model #</u>	<u>Asset #</u>	<u>Cal Due</u>
EMCO	Antenna, Horn, 1-18 GHz (SA40-Red)	3115	1142	07-Jun-08
Rohde & Schwarz	Power Meter, Single Channel	NRVS	1290	12-Jul-08
Hewlett Packard	Spectrum Analyzer 9 kHz - 40 GHz, FT (SA40) Blue	8564E (84125C)	1393	15-Jan-09
Hewlett Packard	Microwave Preamplifier, 1-26.5GHz	8449B	1780	06-Nov-08
Rohde & Schwarz	Power Sensor, 1 uW-100 mW, DC-18 GHz, 50ohms	NRV-Z51	1797	21-Aug-08

Radio Spurious Emissions, 01-Jun-08**Engineer: skhushzad**

<u>Manufacturer</u>	<u>Description</u>	<u>Model #</u>	<u>Asset #</u>	<u>Cal Due</u>
EMCO	Antenna, Horn, 1-18 GHz (SA40-Red)	3115	1142	07-Jun-08
Hewlett Packard	Spectrum Analyzer 9 kHz - 40 GHz, FT (SA40) Blue	8564E (84125C)	1393	15-Jan-09
Hewlett Packard	Microwave Preamplifier, 1-26.5GHz	8449B	1780	06-Nov-08

Radiated Emissions, 1000 - 18,000 MHz, 03-Jun-08**Engineer: Ben Jing**

<u>Manufacturer</u>	<u>Description</u>	<u>Model #</u>	<u>Asset #</u>	<u>Cal Due</u>
Hewlett Packard	Microwave Preamplifier, 1-26.5GHz	8449B	785	29-Jun-08
EMCO	Antenna, Horn, 1-18 GHz (SA40-Red)	3115	1142	07-Jun-08
Rohde & Schwarz	Power Meter, Single Channel	NRVS	1534	05-Mar-09
Micro-Tronics	Band Reject Filter, 5150-5350 MHz	BRC50703-02	1729	17-Oct-08
Micro-Tronics	Band Reject Filter, 5470-5725 MHz	BRC50704-02	1730	17-Oct-08
Hewlett Packard	SpecAn 9 kHz - 40 GHz, (SA40) Purple	8564E (84125C)	1771	17-Dec-08

Radiated Emissions, 1000 - 18,000 MHz, 04-Jun-08**Engineer: Ben Jing**

<u>Manufacturer</u>	<u>Description</u>	<u>Model #</u>	<u>Asset #</u>	<u>Cal Due</u>
Hewlett Packard	Microwave Preamplifier, 1-26.5GHz	8449B	785	29-Jun-08
EMCO	Antenna, Horn, 1-18 GHz (SA40-Red)	3115	1142	07-Jun-08
Rohde & Schwarz	Power Meter, Single Channel	NRVS	1534	05-Mar-09
Micro-Tronics	Band Reject Filter, 5470-5725 MHz	BRC50704-02	1730	17-Oct-08
Hewlett Packard	SpecAn 9 kHz - 40 GHz, (SA40) Purple	8564E (84125C)	1771	17-Dec-08

Radiated Emissions, NII 5 GHz band-edge , 06-Jun-08**Engineer: Ben Jing**

<u>Manufacturer</u>	<u>Description</u>	<u>Model #</u>	<u>Asset #</u>	<u>Cal Due</u>
EMCO	Antenna, Horn, 1-18 GHz (SA40-Red)	3115	1142	07-Jul-08
Hewlett Packard	SpecAn 9 kHz - 40 GHz, (SA40) Purple	8564E (84125C)	1771	17-Dec-08

Radiated Emissions, 1000 - 18,000 MHz, 07-Jun-08**Engineer: Ben Jing**

<u>Manufacturer</u>	<u>Description</u>	<u>Model #</u>	<u>Asset #</u>	<u>Cal Due</u>
Hewlett Packard	Microwave Preamplifier, 1-26.5GHz	8449B	263	28-May-09
EMCO	Antenna, Horn, 1-18 GHz (SA40-Red)	3115	1142	07-Jul-08
Hewlett Packard	SpecAn 9 kHz - 40 GHz, (SA40) Purple	8564E (84125C)	1771	17-Dec-08

Radio Antenna Port (Power and Spurious Emissions), 11-Apr-08

Engineer: jcaizzi

<u>Manufacturer</u>	<u>Description</u>	<u>Model #</u>	<u>Asset #</u>	<u>Cal Due</u>
Rohde & Schwarz	Power Meter, Single Channel	NRVS	1290	12-Jul-08
Hewlett Packard	SpecAn 9 kHz - 40 GHz, (SA40) Purple	8564E (84125C)	1771	17-Dec-08
Rohde & Schwarz	Power Sensor, 1 uW-100 mW, DC-18 GHz, 50ohms	NRV-Z51	1797	21-Aug-08

Radio Antenna Port (Power and Spurious Emissions), 14-Apr-08

Engineer: Suhaila Khushzad

<u>Manufacturer</u>	<u>Description</u>	<u>Model #</u>	<u>Asset #</u>	<u>Cal Due</u>
Rohde & Schwarz	Power Meter, Single Channel	NRVS	1290	12-Jul-08
Hewlett Packard	SpecAn 9 kHz - 40 GHz, (SA40) Purple	8564E (84125C)	1771	17-Dec-08

EXHIBIT 2: Test Measurement Data

T71037 (U-NII rf port measurements)	66 Pages
T71374 (U-NII radiated emissions)	85 Pages
T71040 (AC Conducted Emissions)	4 Pages



EMC Test Data

Client:	Intel	Job Number:	J70979
Model:	512-an MMW	T-Log Number:	T71037
		Account Manager:	Dean Eriksen
Contact:	Robert Paxman		-
Emissions Standard(s):	FCC 15 E / RSS -210 (RF Port)	Class:	NII / LELAN
Immunity Standard(s):	-	Environment:	-

EMC Test Data - RF Port Measurements (U-NII Bands)

For The

Intel

Model

512-an MMW

Date of Last Test:

Client:	Intel	Job Number:	J70979
Model:	512-an MMW	T-Log Number:	T71037
Contact:	Robert Paxman	Account Manager:	Dean Eriksen
Standard:	FCC 15 E / RSS -210 (RF Port)	Class:	N/A

RSS 210 and FCC 15.E Power Measurement Summary

The table below compares the measured output power (measured using the UNII test method) with the power measured using an average power meter (Pavg) and is for reference purposes.

802.11a - Ethertronics Antenna

Frequency (MHz)	Software Setting	Bandwidth		Output Power ¹ dBm		Power (Watts)	PSD ² dBm/MHz			Pavg
		26dB	99% ⁴	Measured	Limit		Measured	FCC Limit	RSS Limit ³	
5180	27.0	24.6	17.0	12.9	17.0	0.019	0.7	4.0	10.0	16.5
5200	27.5	28.0	17.0	13.7	17.0	0.023	1.1	4.0	10.0	16.6
5240	26.5	27.6	17.0	13.7	17.0	0.023	1.1	4.0	10.0	16.6
5260	26.0	26.8	17.0	13.4	24.0	0.022	0.7	11.0	11.0	16.6
5280	25.5	28.0	17.0	13.1	24.0	0.020	0.5	11.0	11.0	16.5
5320	24.5	22.4	17.1	13.0	24.0	0.020	0.4	11.0	11.0	16.6
5500	28.0	36.4	17.1	16.5	24.0	0.045	3.9	11.0	11.0	19.1
5600	25.0	26.4	17.1	12.7	24.0	0.019	0.3	11.0	11.0	16.6
5700	26.0	24.8	17.1	12.1	24.0	0.016	-0.4	11.0	11.0	16.5

With universe antenna, where different from above

5180	29.0									15.8
------	------	--	--	--	--	--	--	--	--	------

802.11n20MHz, Ethertronics and Universe Antennas

Frequency (MHz)	Software Setting	Bandwidth		Output Power ¹ dBm		Power (Watts)	PSD ² dBm/MHz			Pavg
		26dB	99% ⁴	Measured	Limit		Measured	FCC Limit	RSS Limit ³	
5180	28.5	26.8	18.1	14.4	17.0	0.028	1.6	4.0	10.0	16.5
5200	26.5	23.0	18.1	13.1	17.0	0.020	0.3	4.0	10.0	16.5
5240	25.5	23.1	18.1	12.8	17.0	0.019	0.0	4.0	10.0	16.5
5260	25.5	22.8	18.1	13.2	24.0	0.021	0.5	11.0	11.0	16.7
5280	24.5	22.6	18.1	12.6	24.0	0.018	-0.3	11.0	11.0	16.5
5320	25.0	23.8	18.2	13.6	24.0	0.023	0.8	11.0	11.0	16.5
5500	29.0	43.8	18.4	17.3	24.0	0.054	4.4	11.0	11.0	16.6
5600	25.5	23.3	18.2	13.3	24.0	0.021	0.5	11.0	11.0	16.5
5700	28.0	36.5	18.2	13.9	24.0	0.025	1.3	11.0	11.0	16.6

802.11n40MHz - Ethertronics Antenna

Frequency (MHz)	Software Setting	Bandwidth		Output Power ¹ dBm		Power (Watts)	PSD ² dBm/MHz			Pavg
		26dB	99% ⁴	Measured	Limit		Measured	FCC Limit	RSS Limit ³	
5190	26.0	40.8	36.3	12.9	17.0	0.019	-2.1	4.0	10.0	15.1
5230	26.0	43.8	36.1	13.7	17.0	0.023	-1.3	4.0	10.0	16.6
5270	25.5	42.0	36.1	13.9	24.0	0.025	-1.2	11.0	11.0	16.7
5310	24.0	40.2	36.3	13.2	24.0	0.021	-2.0	11.0	11.0	15.7
5510	23.5	41.7	36.3	13.4	24.0	0.022	-1.8	11.0	11.0	16.2
5590	23.0	40.8	36.3	12.0	24.0	0.016	-3.3	11.0	11.0	16.9
5670	26.5	51.2	36.4	13.9	24.0	0.025	-1.5	11.0	11.0	16.9

With universe antenna, where different from above

5190	22.0			<- re-measured band edges to confirm powers						10.9
5310	19.5			<- re-measured band edges to confirm powers						11.4

Client:	Intel	Job Number:	J70979
Model:	512-an MMW	T-Log Number:	T71037
		Account Manager:	Dean Eriksen
Contact:	Robert Paxman		
Standard:	FCC 15 E / RSS -210 (RF Port)	Class:	N/A

RSS-210 (LELAN) and FCC 15.407(UNII)
Antenna Port Measurements
Power, PSD, Peak Excursion, Bandwidth - Chain A, 802.11a Legacy Mode

Test Specific Details

Objective: The objective of this test session is to perform final qualification testing of the EUT with respect to the specification listed above.

Date of Test: 4/14/2008
 Test Engineer: Rafael Varelas
 Test Location: FT Lab #1

Config. Used: 1
 Config Change: None
 EUT Voltage: Powered from Host

General Test Configuration

When measuring the conducted emissions from the EUT's antenna port, the antenna port of the EUT was connected to the spectrum analyzer or power meter via a suitable attenuator to prevent overloading the measurement system. All measurements are corrected to allow for the external attenuators and cables used.

Ambient Conditions: Temperature: 20.6 °C
 Rel. Humidity: 33 %

Summary of Results

Run #	Test Performed	Limit	Pass / Fail	Result / Margin
1	Power, 5150 - 5250MHz	15.407(a) (1), (2)	Pass	13.7 dBm (23mW)
1	Power, 5250 - 5350MHz	15.407(a) (1), (2)	Pass	13.4 dBm (22mW)
1	Power, 5470 - 5725MHz	15.407(a) (1), (2)	Pass	16.5 dBm (45mW)
1	PSD, 5150 - 5250MHz	15.407(a) (1), (2)	Pass	1.1 dBm/MHz
1	PSD, 5250 - 5350MHz	15.407(a) (1), (2)	Pass	0.7 dBm/MHz
1	PSD, 5470 - 5725MHz	15.407(a) (1), (2)	Pass	3.9 dBm/MHz
1	26dB Bandwidth	15.407	-	36.4 MHz
1	99% Bandwidth	RSS 210	-	17.1 MHz
2	Peak Excursion Envelope	15.407(a) (6)	Pass	10.8 dB

Modifications Made During Testing

No modifications were made to the EUT during testing

Deviations From The Standard

No deviations were made from the requirements of the standard.

Client:	Intel	Job Number:	J70979
Model:	512-an MMW	T-Log Number:	T71037
		Account Manager:	Dean Eriksen
Contact:	Robert Paxman		
Standard:	FCC 15 E / RSS -210 (RF Port)	Class:	N/A

Run #1: Bandwidth, Output Power and Power spectral Density

 Antenna Gain (dBi): 5

Frequency (MHz)	Software Setting	Bandwidth		Output Power ¹ dBm		Power (Watts)	PSD ² dBm/MHz			Result
		26dB	99% ⁴	Measured	Limit		Measured	FCC Limit	RSS Limit ³	
5180	27.0	24.6	17.0	12.9	17.0	0.019	0.7	4.0	5.0	Pass
5200	27.5	28.0	17.0	13.7	17.0	0.023	1.1	4.0	5.0	Pass
5240	26.5	27.6	17.0	13.7	17.0	0.023	1.1	4.0	5.0	Pass
5260	26.0	26.8	17.0	13.4	24.0	0.022	0.7	11.0	11.0	Pass
5280	25.5	28.0	17.0	13.1	24.0	0.020	0.5	11.0	11.0	Pass
5320	24.5	22.4	17.1	13.0	24.0	0.020	0.4	11.0	11.0	Pass
5500	28.0	36.4	17.1	16.5	24.0	0.045	3.9	11.0	11.0	Pass
5600	25.0	26.4	17.1	12.7	24.0	0.019	0.3	11.0	11.0	Pass
5700	26.0	24.8	17.1	12.1	24.0	0.016	-0.4	11.0	11.0	Pass

Note 1:	Output power measured using a spectrum analyzer (see plots below): RBW=1MHz, VB=3 MHz, sample detector, power averaging on (transmitted signal was continuous) and power integration over 50 MHz
Note 2:	Measured using the same analyzer settings used for output power.
Note 3:	For RSS-210 the limit for the 5150 - 5250 MHz band accounts for the antenna gain as the maximum eirp allowed is 10dBm/MHz. The limits are also corrected for instances where the highest measured value of the PSD exceeds the average PSD (calculated from the measured power divided by the measured 99% bandwidth) by more than 3dB by the amount that the measured value exceeds the average by more than 3dB.
Note 4:	99% Bandwidth measured in accordance with RSS GEN - RB > 1% of span and VB >=3xRB

Client: Intel	Job Number: J70979
Model: 512-an MMW	T-Log Number: T71037
Contact: Robert Paxman	Account Manager: Dean Eriksen
Standard: FCC 15 E / RSS -210 (RF Port)	Class: N/A

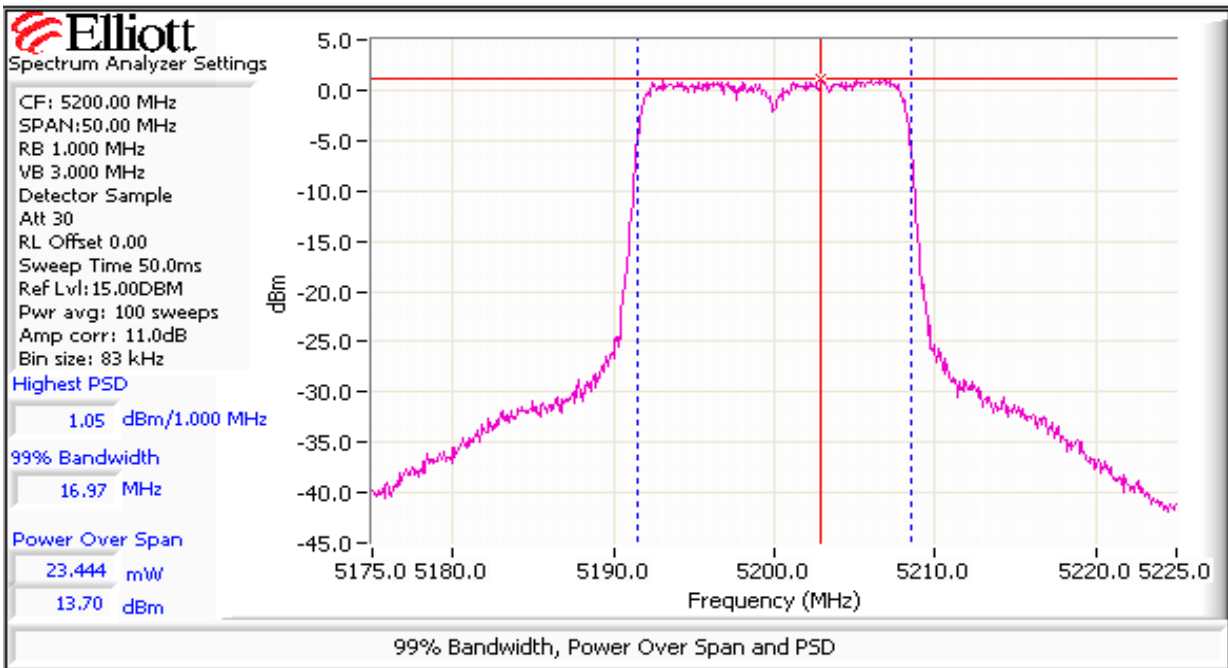
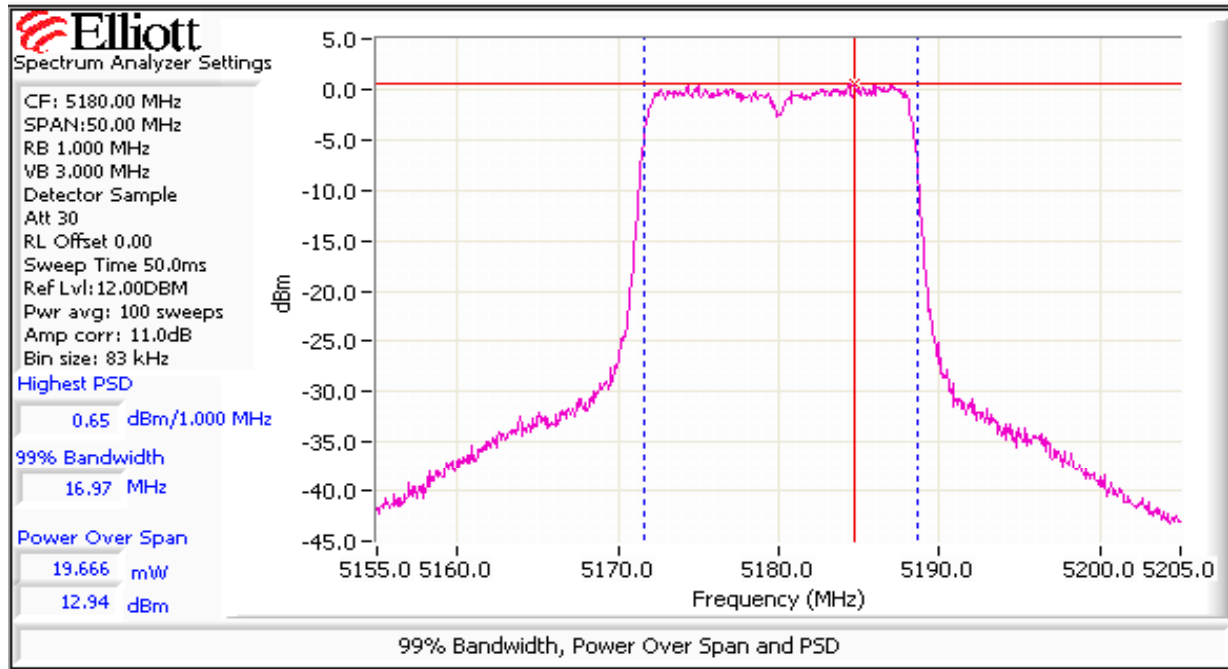

Client: Intel	Job Number: J70979
Model: 512-an MMW	T-Log Number: T71037
Contact: Robert Paxman	Account Manager: Dean Eriksen
Standard: FCC 15 E / RSS -210 (RF Port)	Class: N/A

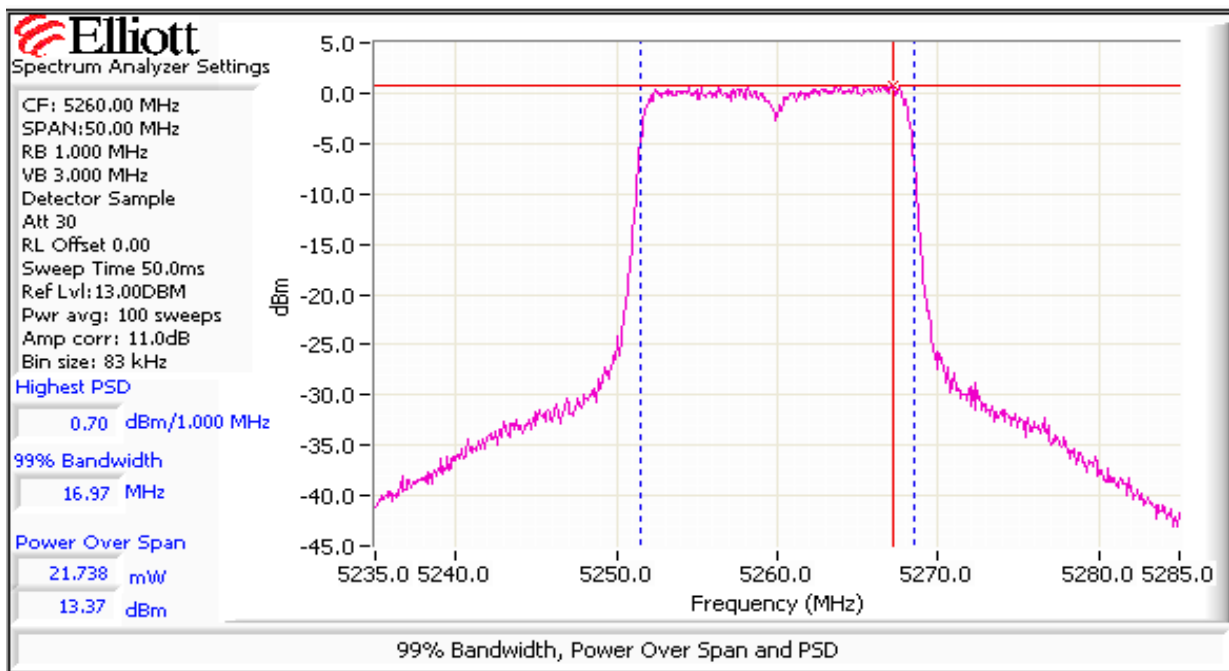
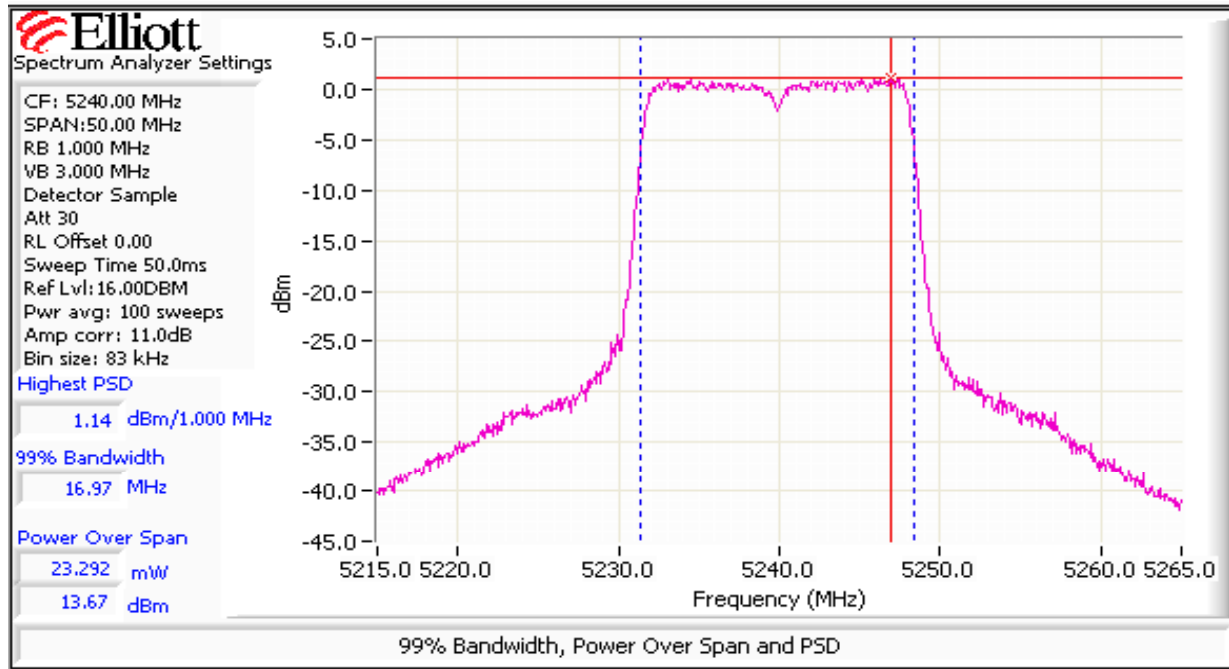

Client: Intel	Job Number: J70979
Model: 512-an MMW	T-Log Number: T71037
Contact: Robert Paxman	Account Manager: Dean Eriksen
Standard: FCC 15 E / RSS -210 (RF Port)	Class: N/A

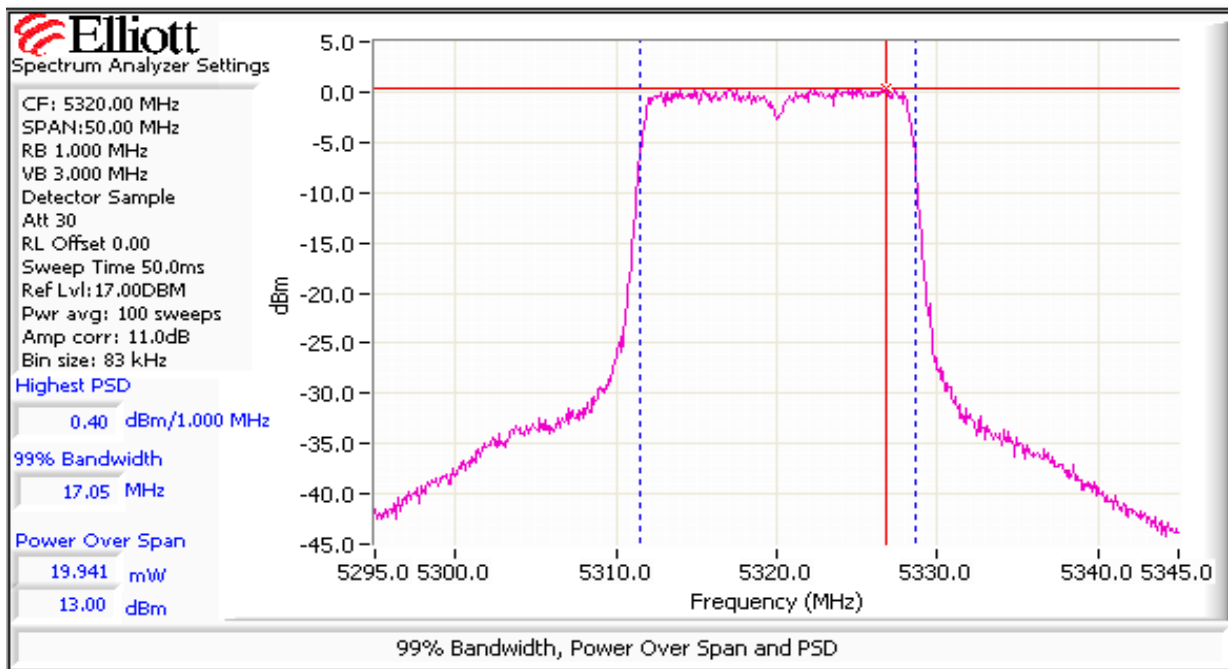
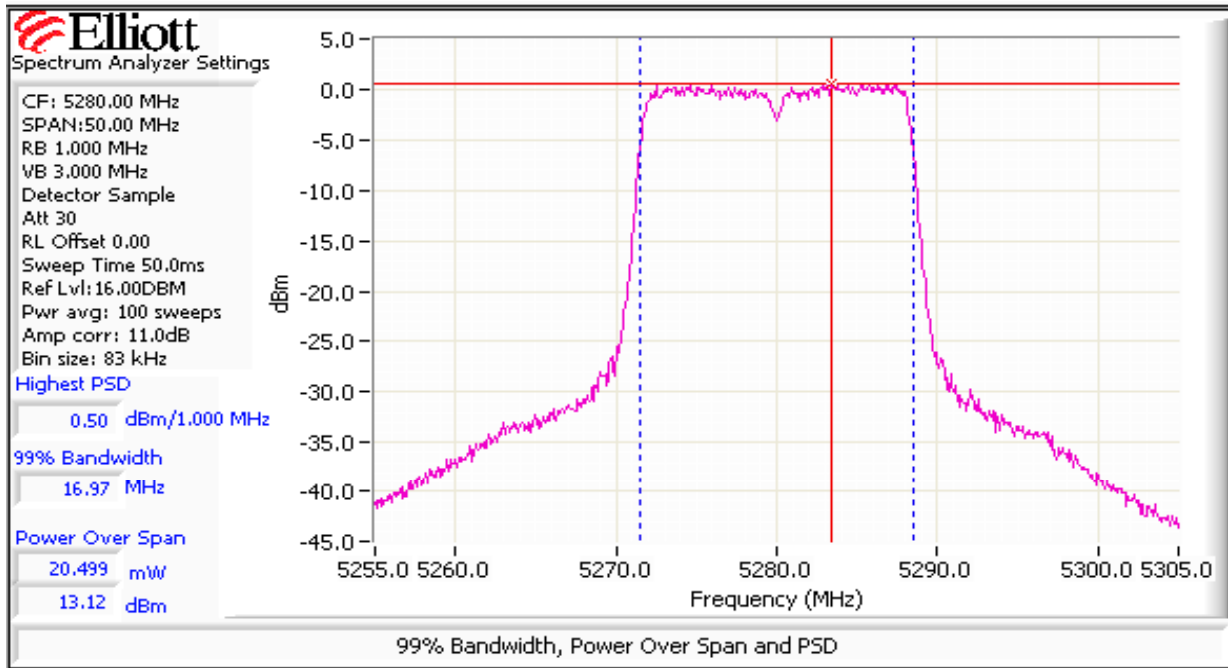

Client: Intel	Job Number: J70979
Model: 512-an MMW	T-Log Number: T71037
Contact: Robert Paxman	Account Manager: Dean Eriksen
Standard: FCC 15 E / RSS -210 (RF Port)	Class: N/A

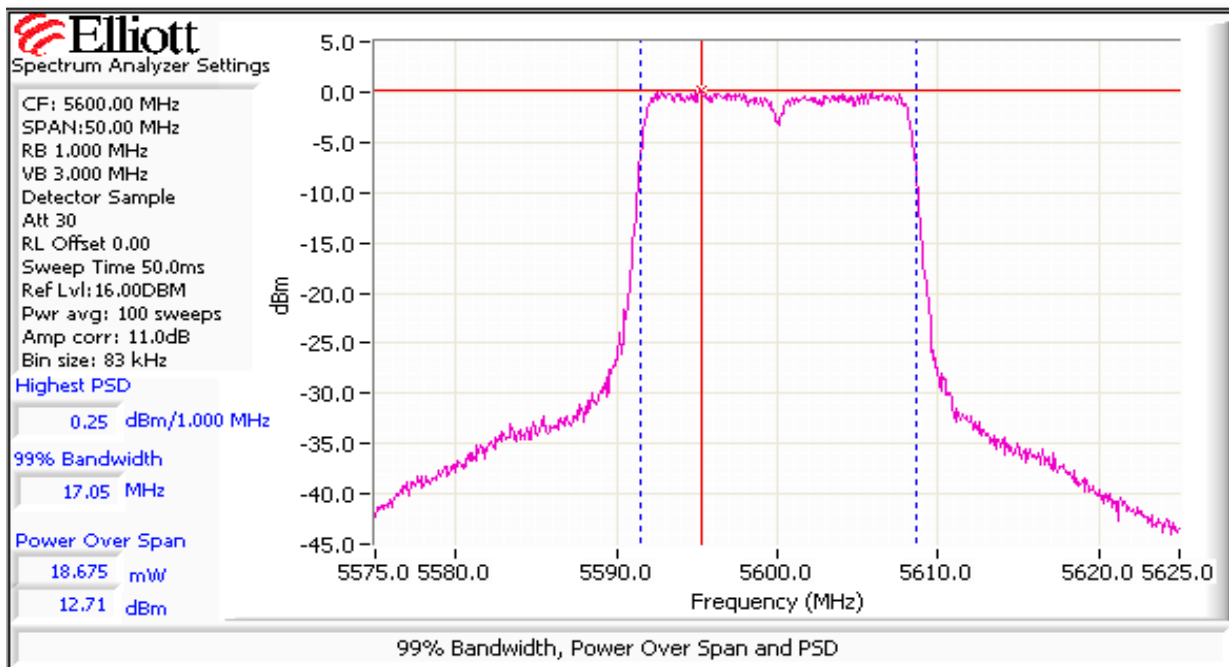
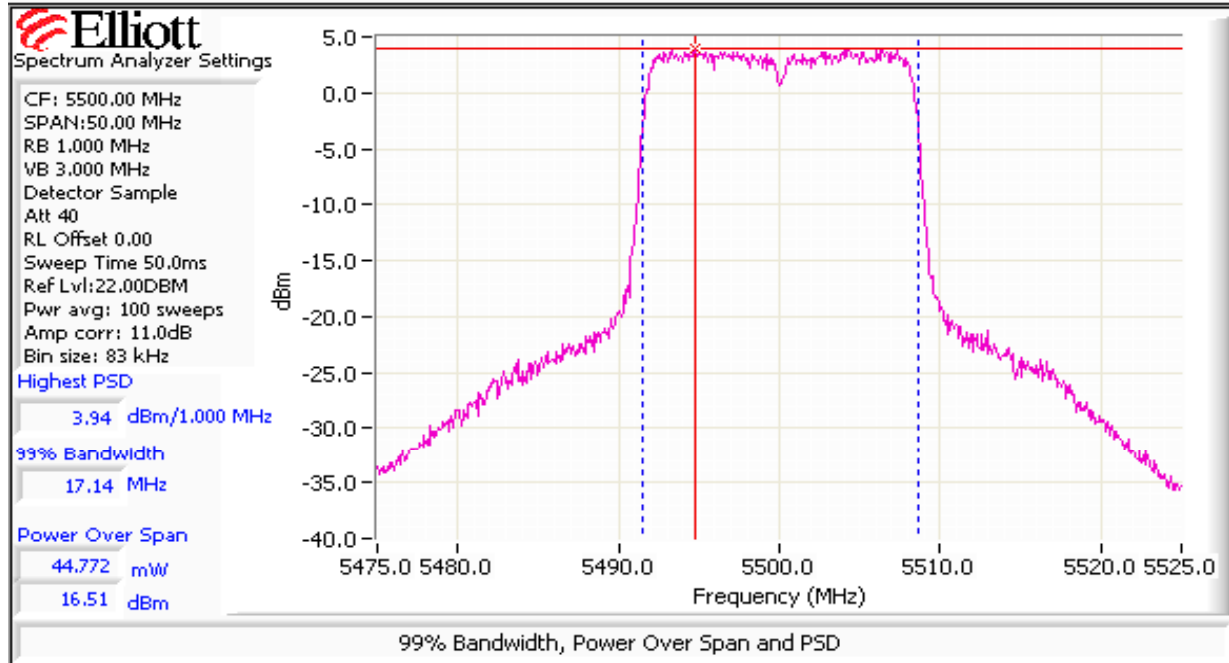

Client: Intel	Job Number: J70979
Model: 512-an MMW	T-Log Number: T71037
Contact: Robert Paxman	Account Manager: Dean Eriksen
Standard: FCC 15 E / RSS -210 (RF Port)	Class: N/A

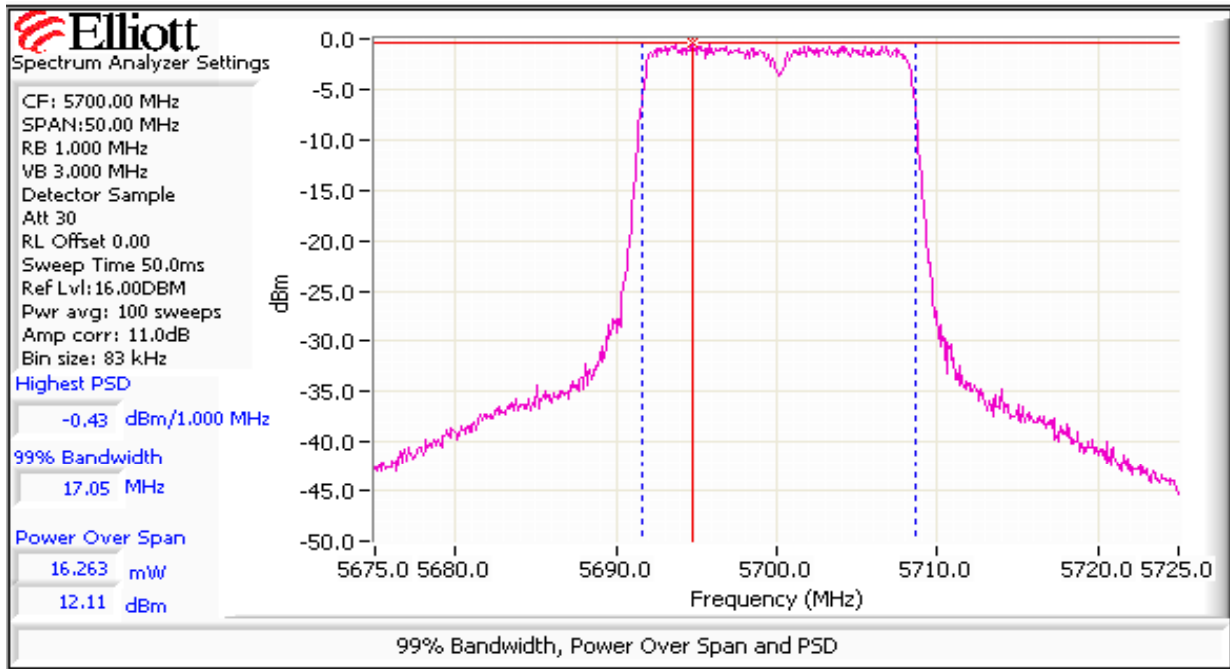

Run #2: Peak Excursion Measurement

Device meets the requirement for the peak excursion

Freq		Peak Excursion(dB)		Freq		Peak Excursion(dB)		
(MHz)	Value	Limit	(MHz)	Value	Limit	(MHz)	Value	Limit
5180	10.0	13.0	5260	9.7	13.0	5500	9.5	13.0
5200	10.8	13.0	5280	9.8	13.0	5600	10.2	13.0
5240	9.8	13.0	5320	10.1	13.0	5700	10.4	13.0

Plots Showing Peak Excursion

Trace A: RBW = VBW = 3MHz, Peak hold
Trace B: RBW = 1 MHz, VBW = 3MHz, Integrated average power

Client: Intel	Job Number: J70979
Model: 512-an MMW	T-Log Number: T71037
Contact: Robert Paxman	Account Manager: Dean Eriksen
Standard: FCC 15 E / RSS -210 (RF Port)	Class: N/A

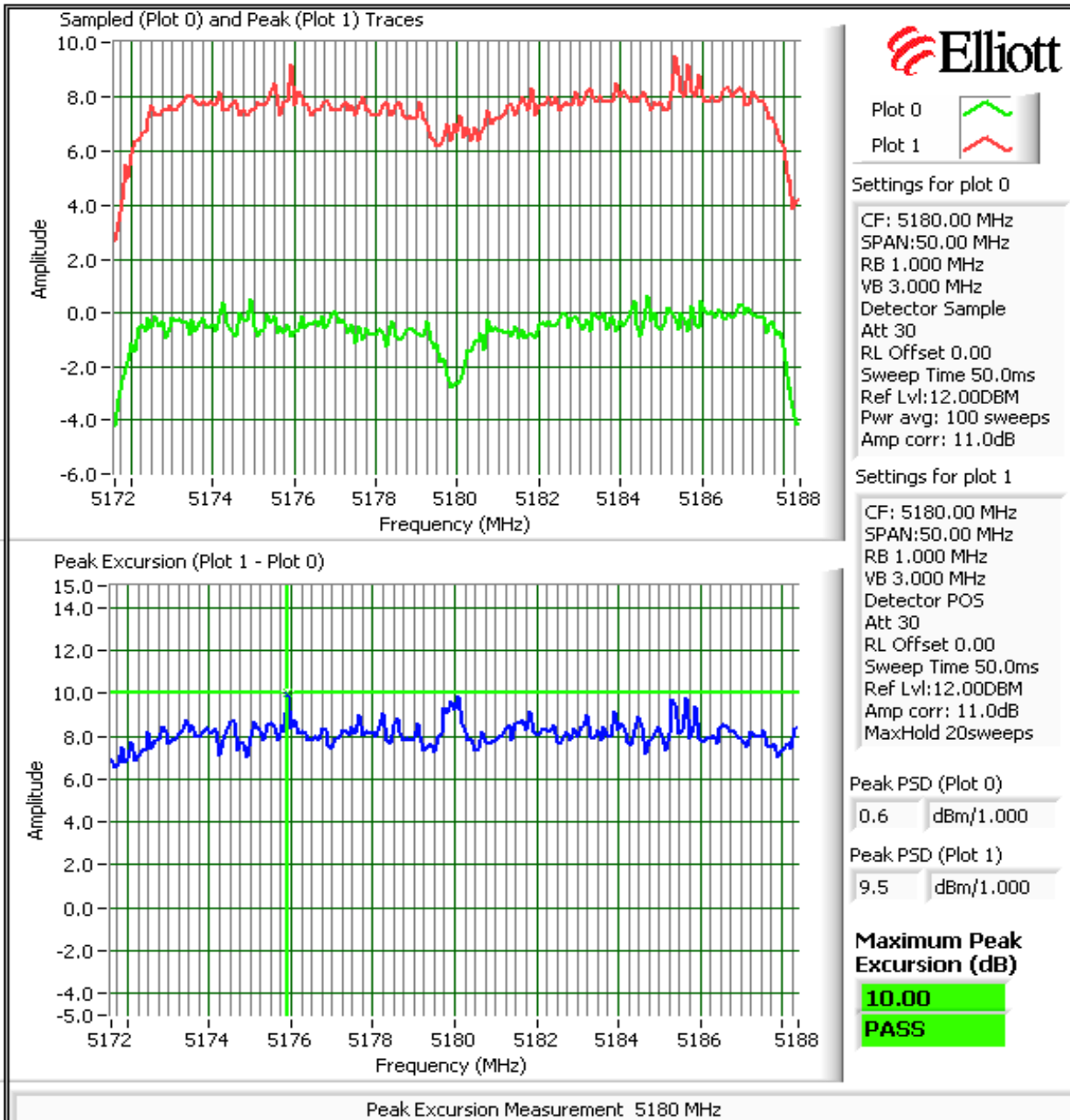

Client: Intel	Job Number: J70979
Model: 512-an MMW	T-Log Number: T71037
Contact: Robert Paxman	Account Manager: Dean Eriksen
Standard: FCC 15 E / RSS -210 (RF Port)	Class: N/A

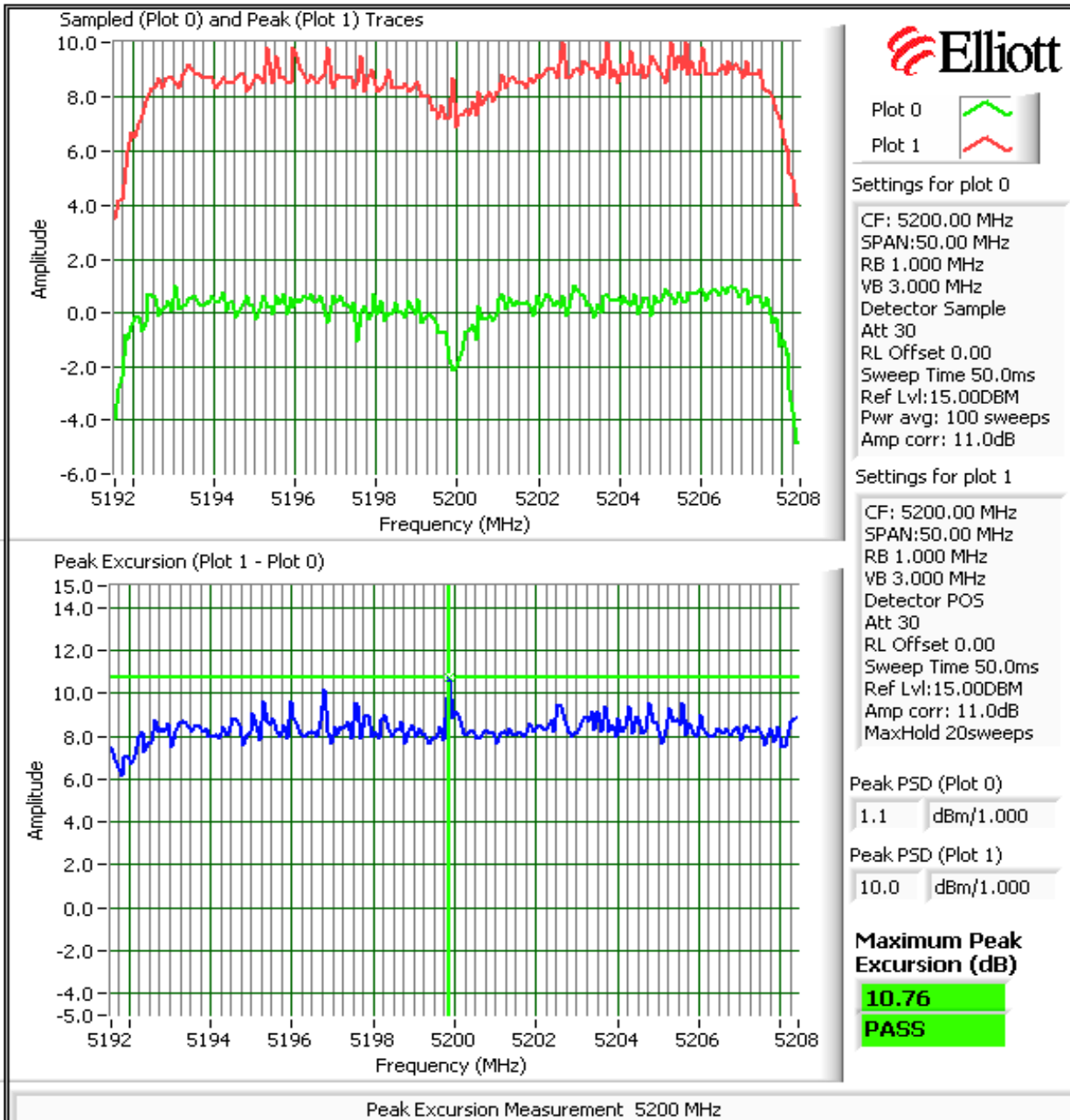

Client: Intel	Job Number: J70979
Model: 512-an MMW	T-Log Number: T71037
Contact: Robert Paxman	Account Manager: Dean Eriksen
Standard: FCC 15 E / RSS -210 (RF Port)	Class: N/A

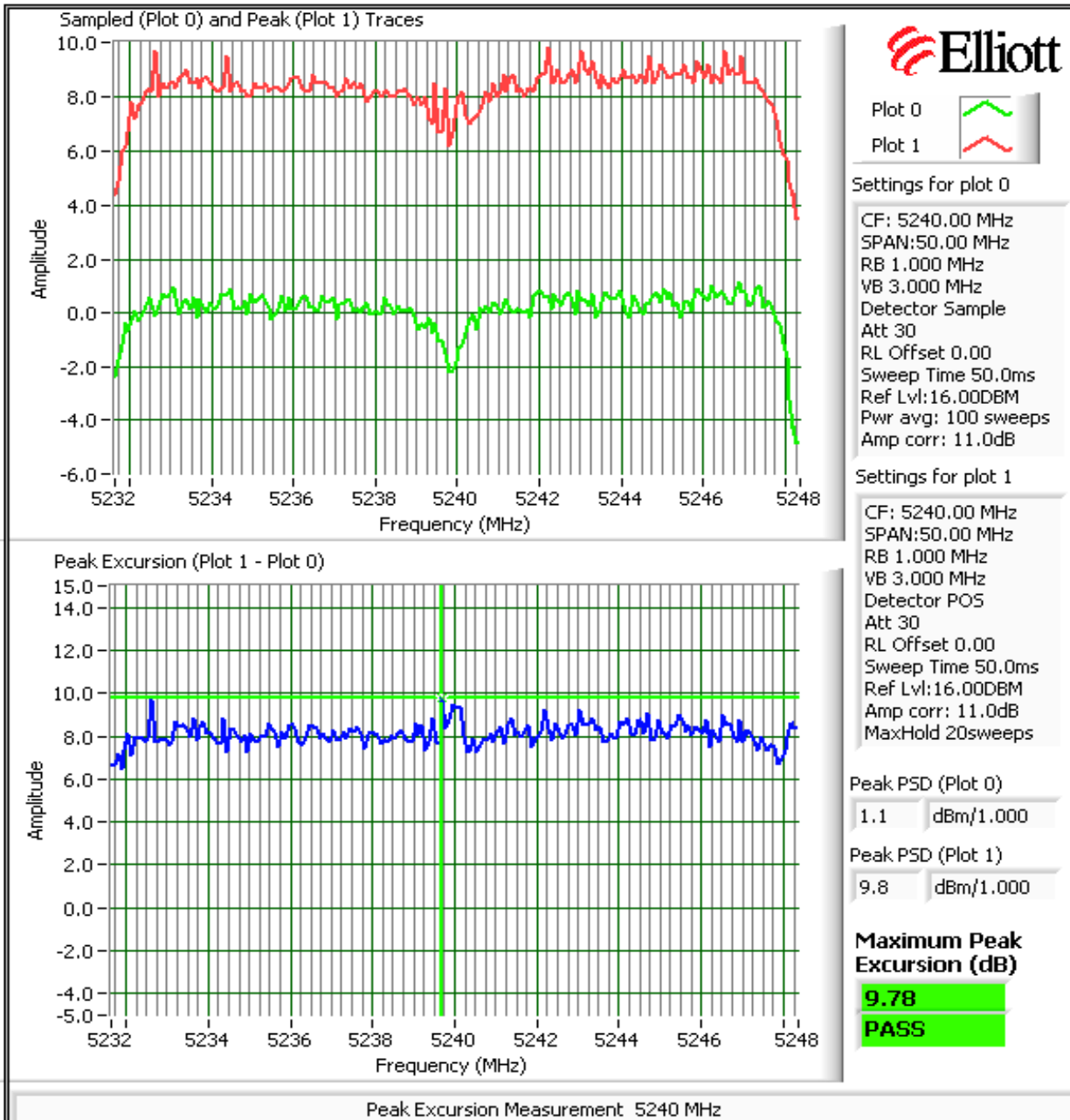

Client: Intel	Job Number: J70979
Model: 512-an MMW	T-Log Number: T71037
Contact: Robert Paxman	Account Manager: Dean Eriksen
Standard: FCC 15 E / RSS -210 (RF Port)	Class: N/A

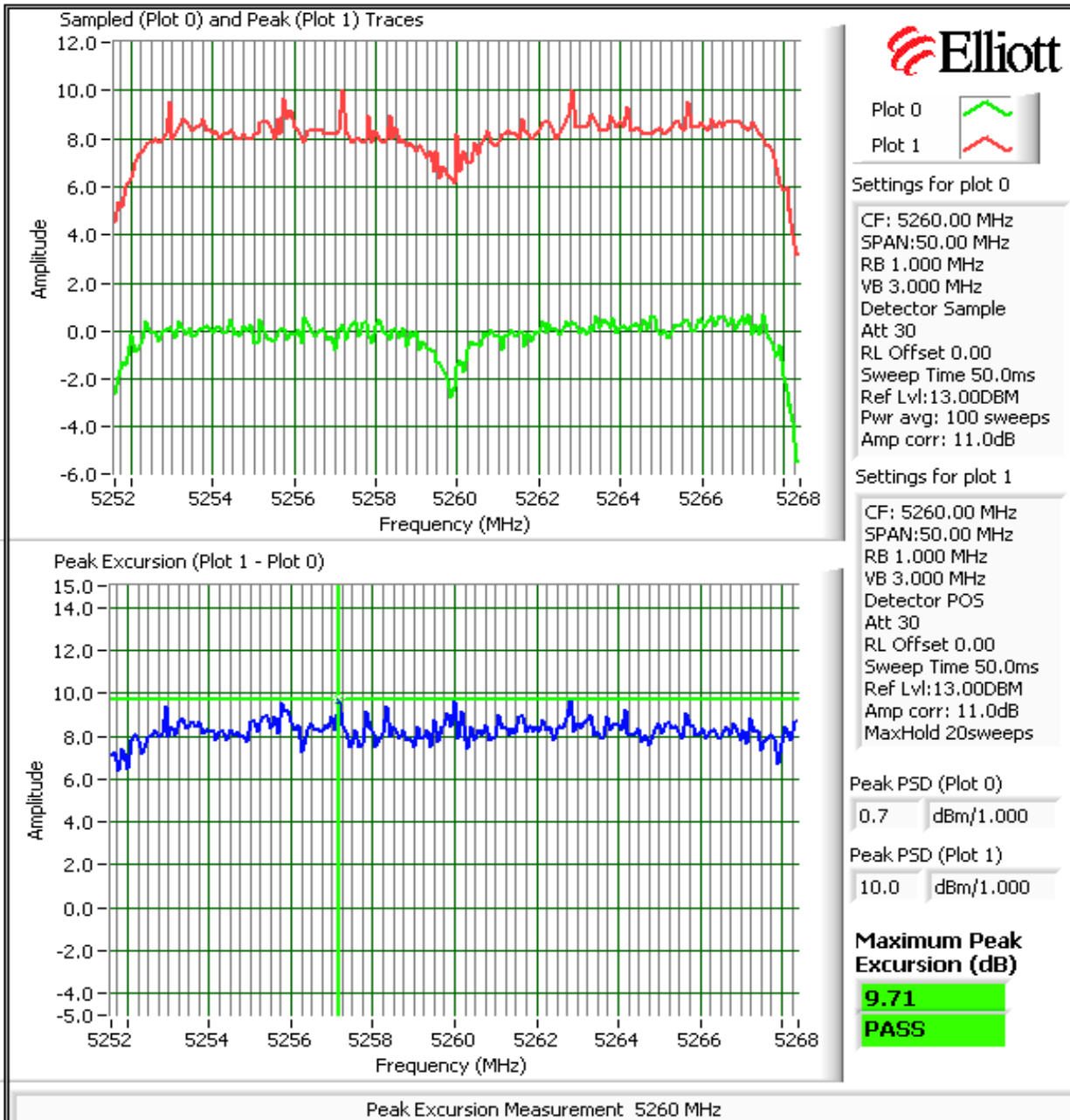

Client: Intel	Job Number: J70979
Model: 512-an MMW	T-Log Number: T71037
Contact: Robert Paxman	Account Manager: Dean Eriksen
Standard: FCC 15 E / RSS -210 (RF Port)	Class: N/A

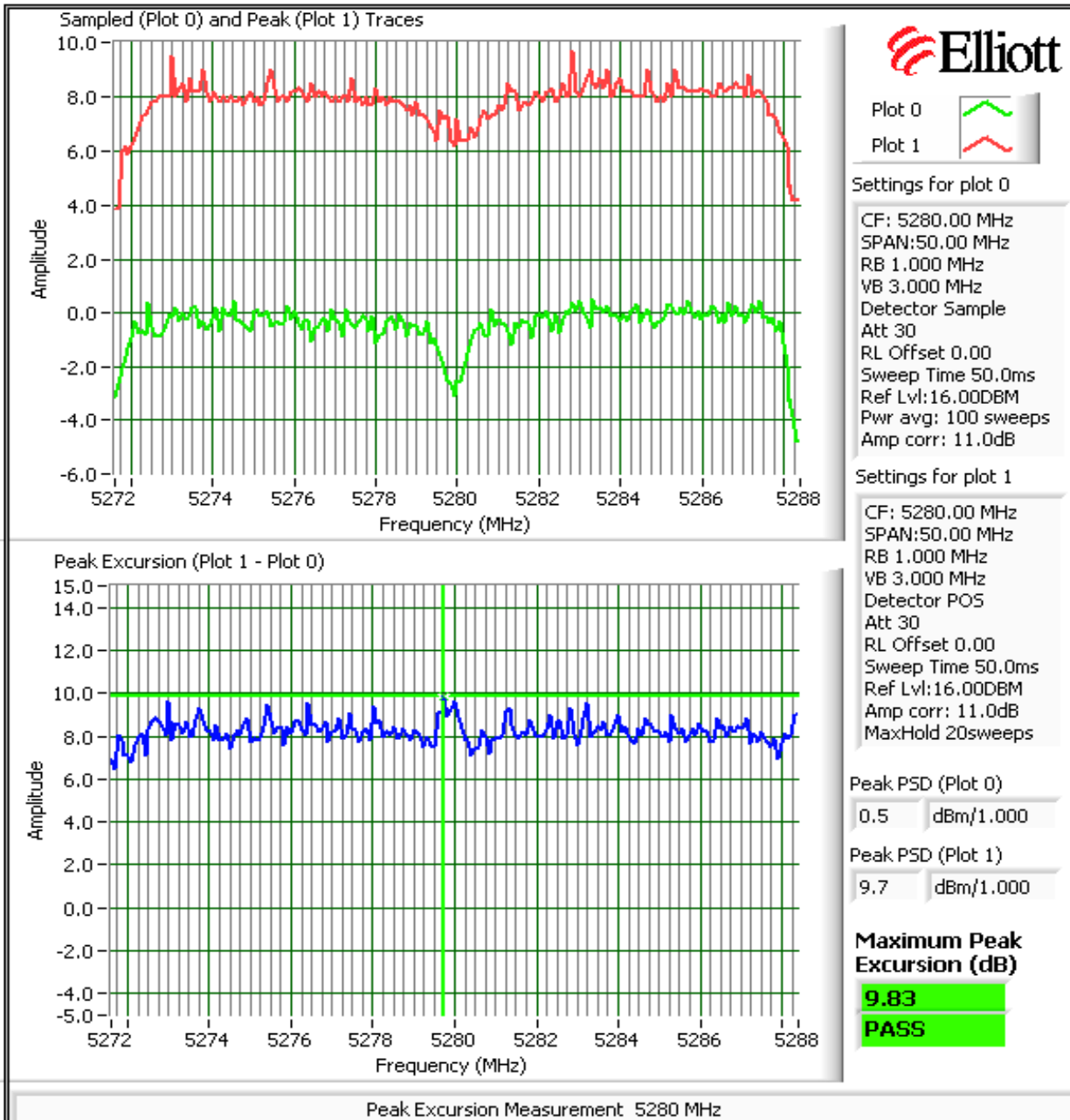

Client: Intel	Job Number: J70979
Model: 512-an MMW	T-Log Number: T71037
Contact: Robert Paxman	Account Manager: Dean Eriksen
Standard: FCC 15 E / RSS -210 (RF Port)	Class: N/A

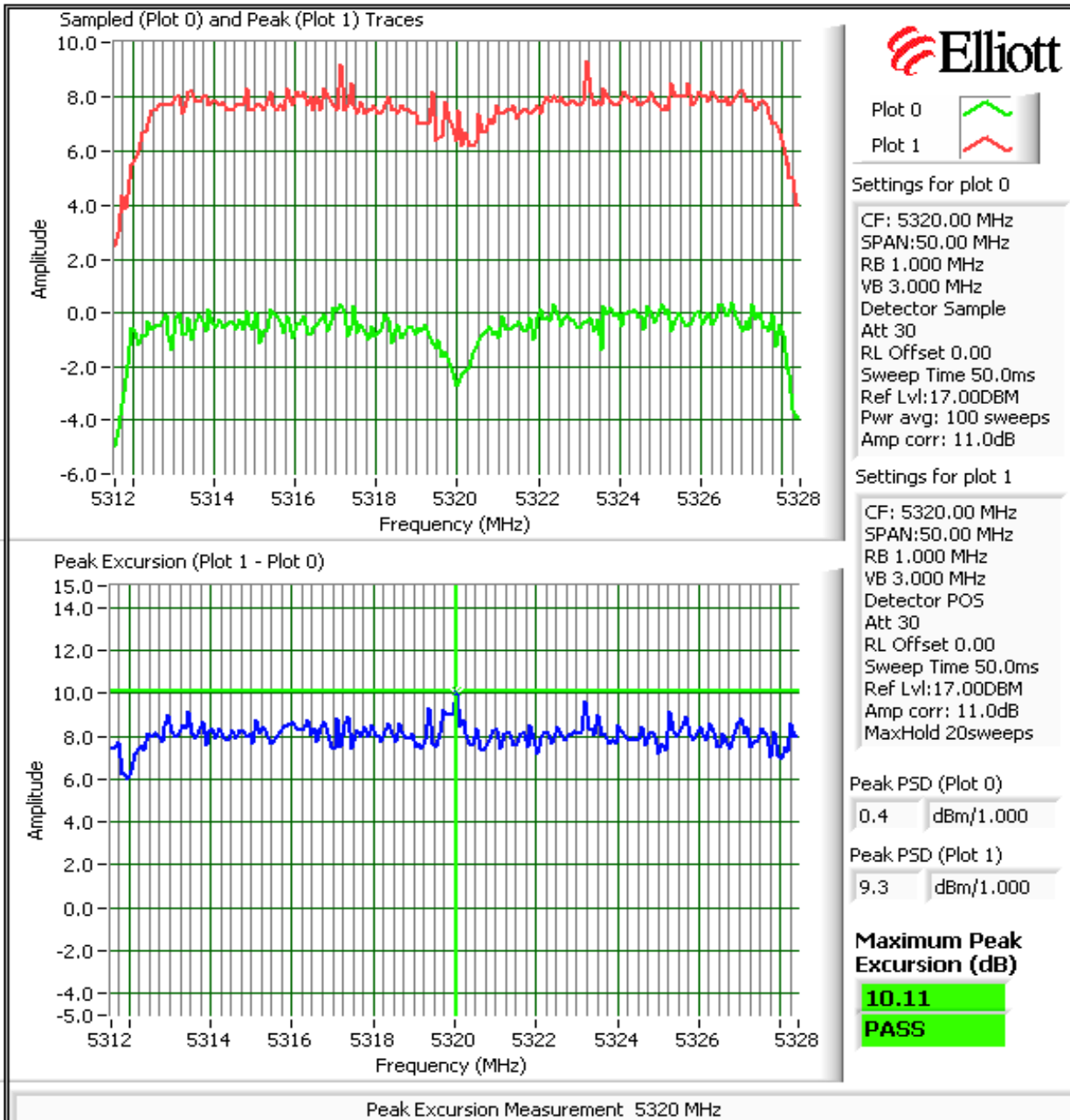

Client: Intel	Job Number: J70979
Model: 512-an MMW	T-Log Number: T71037
Contact: Robert Paxman	Account Manager: Dean Eriksen
Standard: FCC 15 E / RSS -210 (RF Port)	Class: N/A

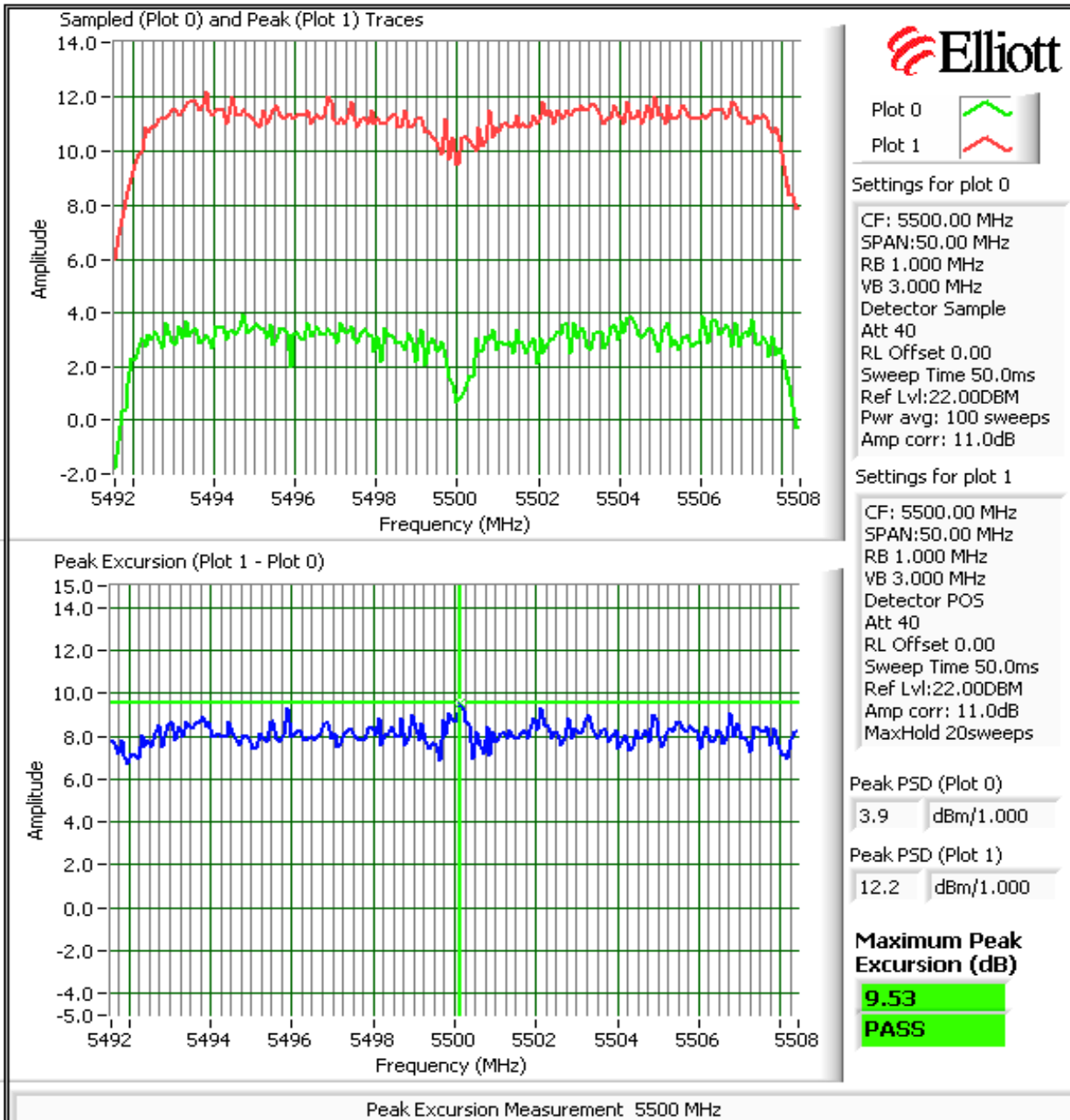

Client: Intel	Job Number: J70979
Model: 512-an MMW	T-Log Number: T71037
Contact: Robert Paxman	Account Manager: Dean Eriksen
Standard: FCC 15 E / RSS -210 (RF Port)	Class: N/A

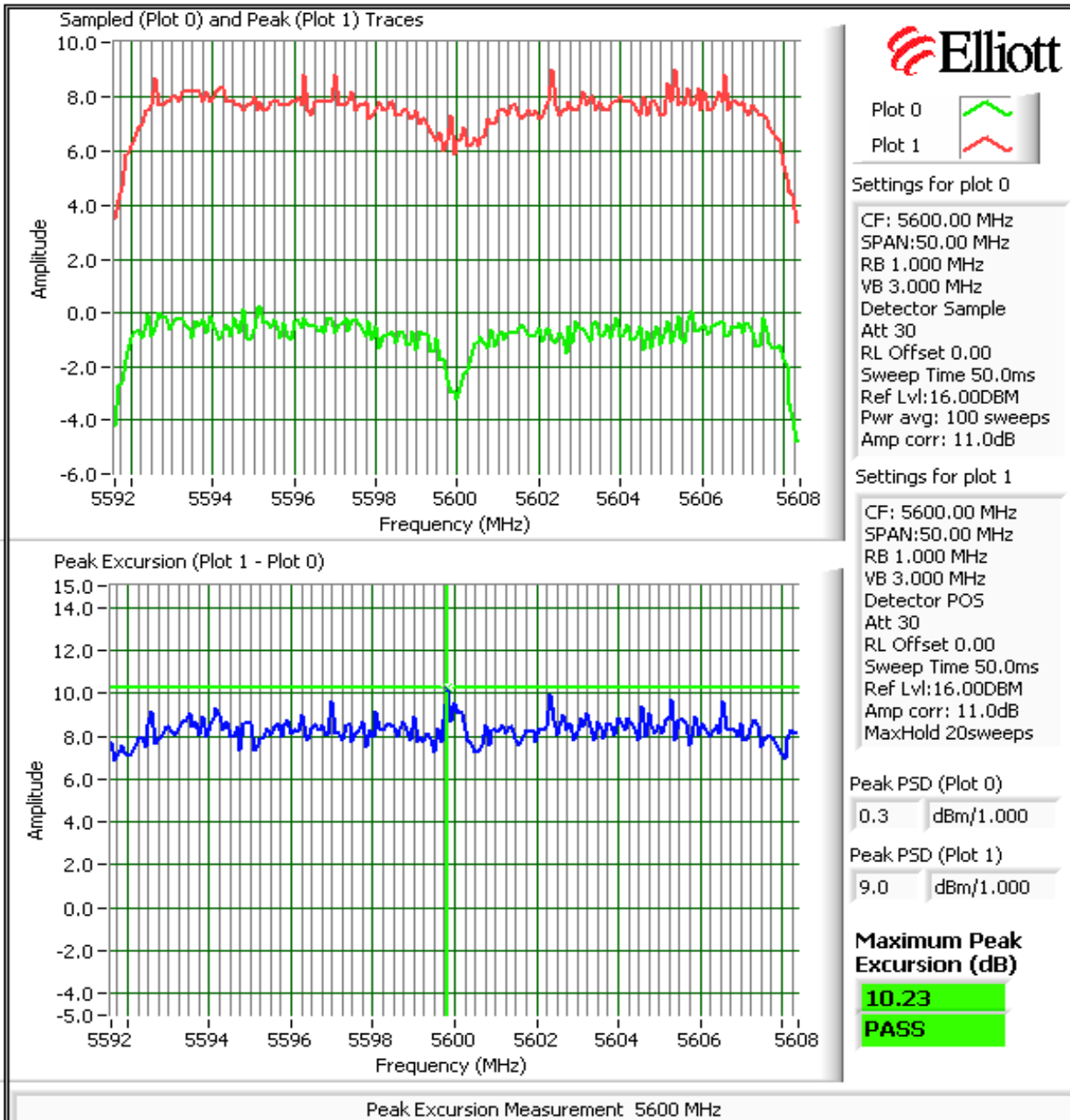

Client: Intel	Job Number: J70979
Model: 512-an MMW	T-Log Number: T71037
Contact: Robert Paxman	Account Manager: Dean Eriksen
Standard: FCC 15 E / RSS -210 (RF Port)	Class: N/A

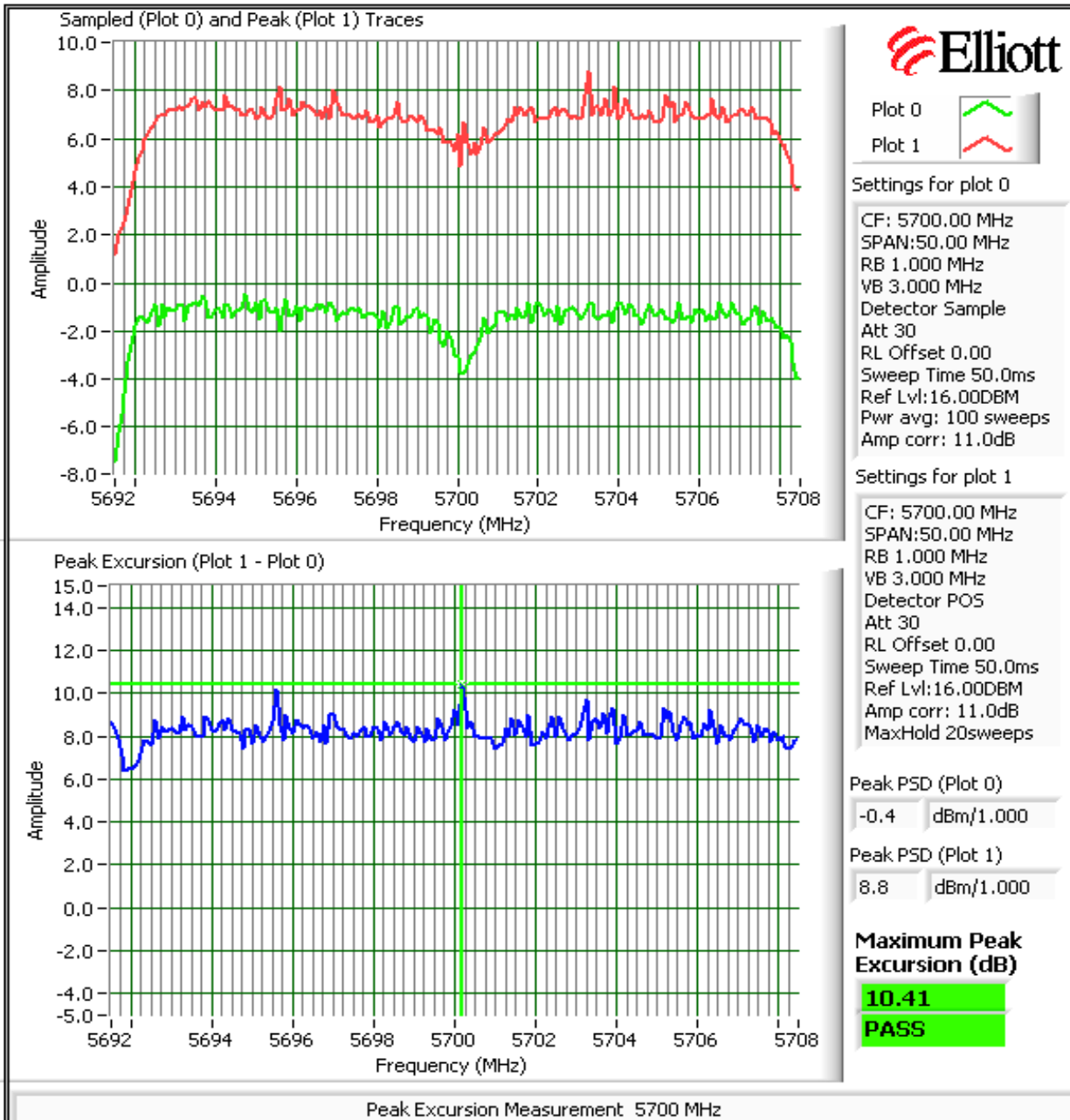

Client:	Intel	Job Number:	J70979
Model:	512-an MMW	T-Log Number:	T71037
		Account Manager:	Dean Eriksen
Contact:	Robert Paxman		
Standard:	FCC 15 E / RSS -210 (RF Port)	Class:	N/A

RSS-210 (LELAN) and FCC 15.407(UNII)
Antenna Port Measurements
Spurious Emissions - 802.11a legacy mode

Test Specific Details

Objective: The objective of this test session is to perform final qualification testing of the EUT with respect to the specification listed above.

Date of Test: 4/14/2008
 Test Engineer: Rafael Varelas
 Test Location: FT Lab #1

Config. Used: 1
 Config Change: None
 EUT Voltage: Powered from Host

General Test Configuration

When measuring the conducted emissions from the EUT's antenna port, the antenna port of the EUT was connected to the spectrum analyzer or power meter via a suitable attenuator to prevent overloading the measurement system. All measurements are corrected to allow for the external attenuators and cables used.

Ambient Conditions: Temperature: 20.6 °C
 Rel. Humidity: 33 %

Summary of Results

Run #	Test Performed	Limit	Pass / Fail	Result / Margin
1	Antenna Conducted - Out of Band Spurious, 802.11a legacy	15.407(b)	Pass	All emissions below the -27dBm/MHz limit

Modifications Made During Testing

No modifications were made to the EUT during testing

Deviations From The Standard

No deviations were made from the requirements of the standard.

Client:	Intel	Job Number:	J70979
Model:	512-an MMW	T-Log Number:	T71037
Contact:	Robert Paxman	Account Manager:	Dean Eriksen
Standard:	FCC 15 E / RSS -210 (RF Port)	Class:	N/A

Run #1: Out Of Band Spurious Emissions - Antenna Conducted, Chain A 20MHz 802.11a

The limit of -27dBm has been corrected to account for the gain of the antenna.

Maximum Antenna Gain: 5.0 dBi
 Spurious Limit: -27.0 dBm/MHz eirp
 Limit Used On Plots ^{Note 1}: -32.0 dBm/MHz

- Note 1: The -27dBm/MHz limit is an eirp limit. The limit for antenna port conducted measurements is adjusted to take into consideration the maximum antenna gain (limit = -27dBm - antenna gain). Radiated field strength measurements for signals more than 50MHz from the bands that are close to the limit are made to determine compliance as the antenna gain is not known at these frequencies.
- Note 2: All spurious signals below 1GHz are measured during digital device radiated emissions test.
- Note 3: Signals that fall in the restricted bands of 15.205 are subject to the limit of 15.209.

Low Channel, Chain A, 5180 MHz

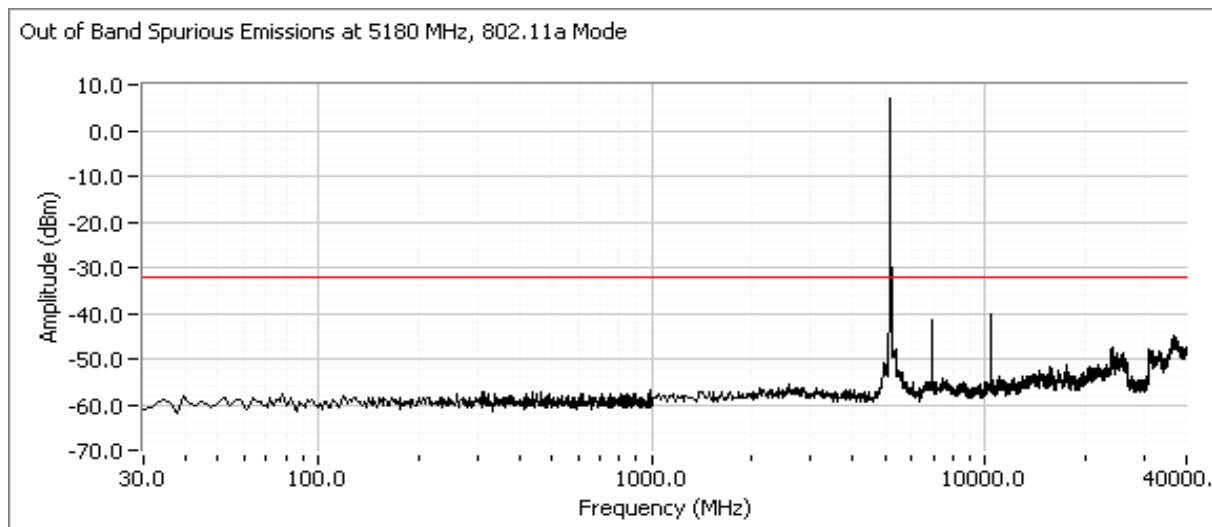

Client: Intel	Job Number: J70979
Model: 512-an MMW	T-Log Number: T71037
Contact: Robert Paxman	Account Manager: Dean Eriksen
Standard: FCC 15 E / RSS -210 (RF Port)	Class: N/A

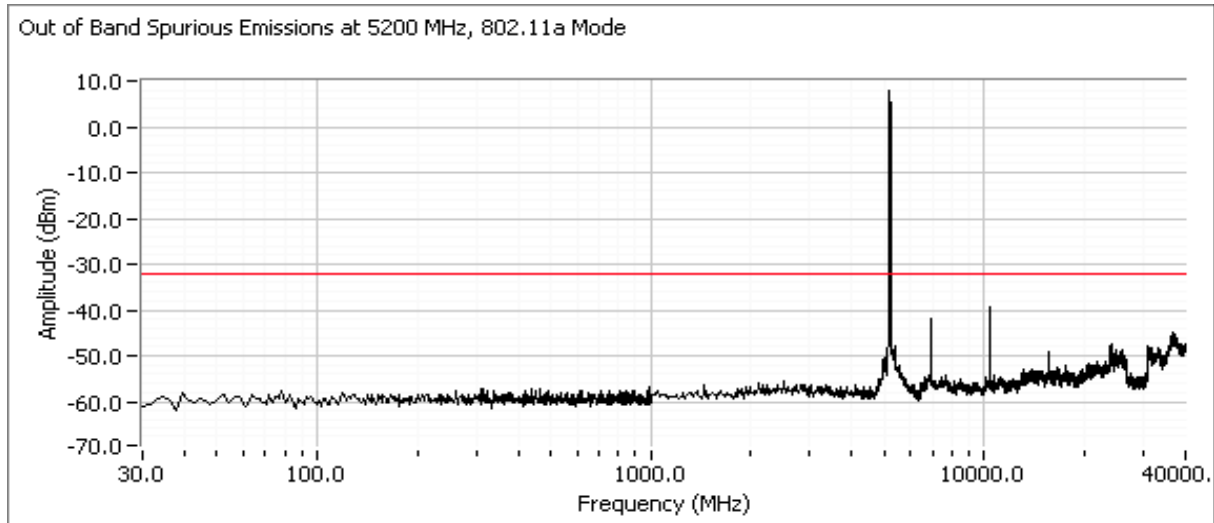
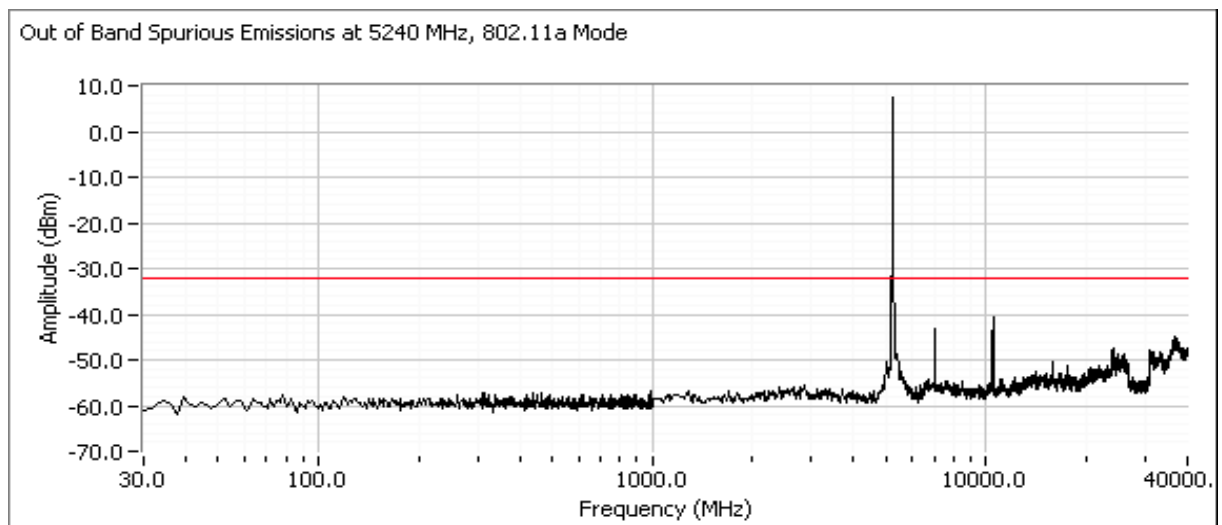
Center Channel, Chain A, 5200 MHz

High Channel, Chain A, 5240 MHz

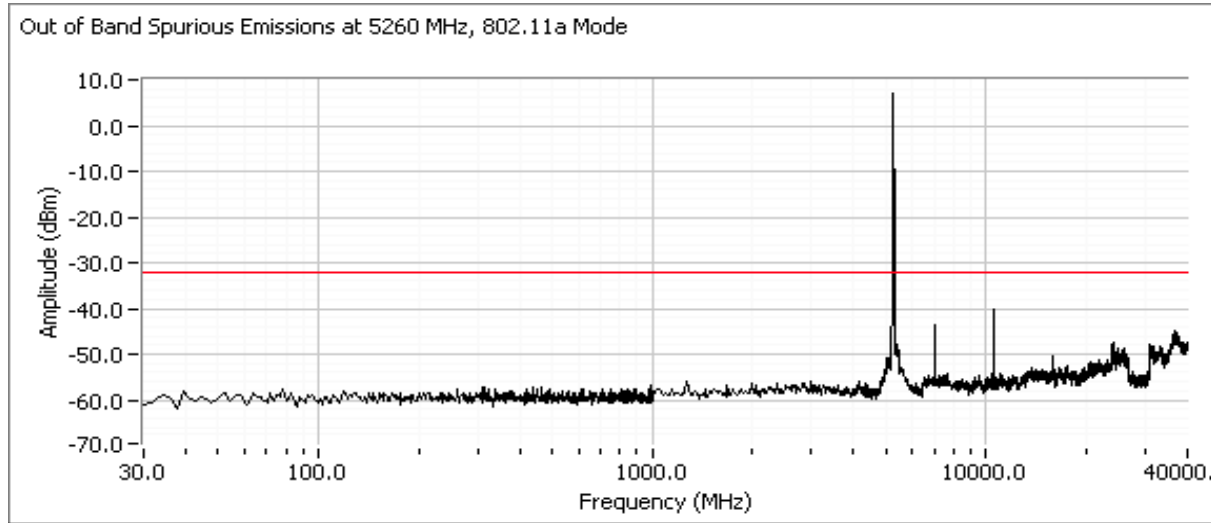
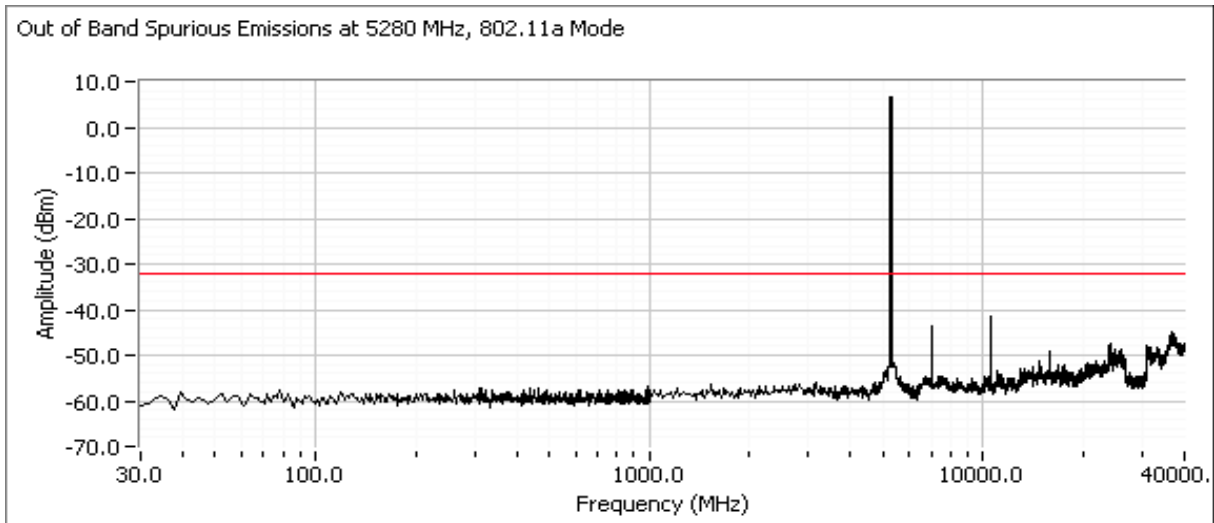
Client: Intel	Job Number: J70979
Model: 512-an MMW	T-Log Number: T71037
Contact: Robert Paxman	Account Manager: Dean Eriksen
Standard: FCC 15 E / RSS -210 (RF Port)	Class: N/A

Low Channel, Chain A, 5260 MHz

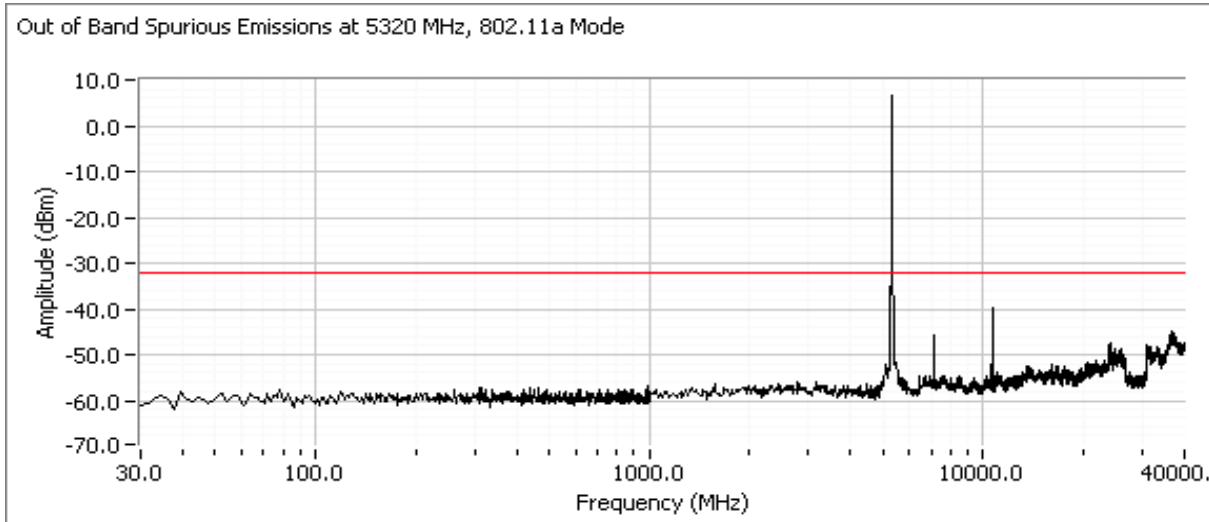
Center Channel, Chain A, 5280 MHz

Client: Intel	Job Number: J70979
Model: 512-an MMW	T-Log Number: T71037
Contact: Robert Paxman	Account Manager: Dean Eriksen
Standard: FCC 15 E / RSS -210 (RF Port)	Class: N/A

High Channel, Chain A, 5320 MHz

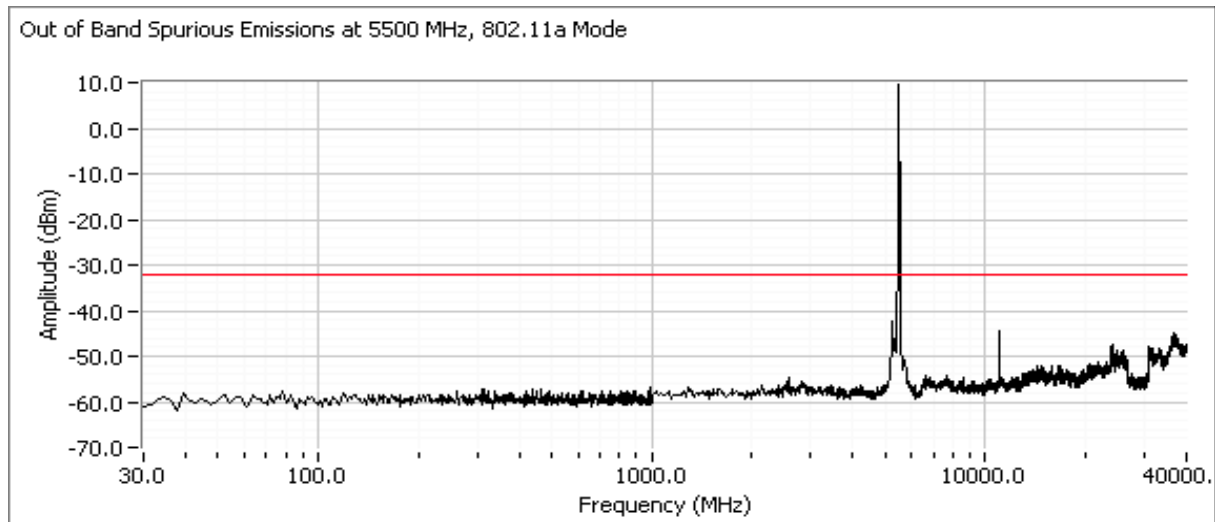
Low Channel, Chain A, 5500 MHz - includes a second plot from 5460 - 5500 MHz, showing compliance with the limit from 5460 - 5470 MHz. Compliance at the 5460 MHz restricted band edge is demonstrated via radiated measurements.



Client: Intel	Job Number: J70979
Model: 512-an MMW	T-Log Number: T71037
Contact: Robert Paxman	Account Manager: Dean Eriksen
Standard: FCC 15 E / RSS -210 (RF Port)	Class: N/A

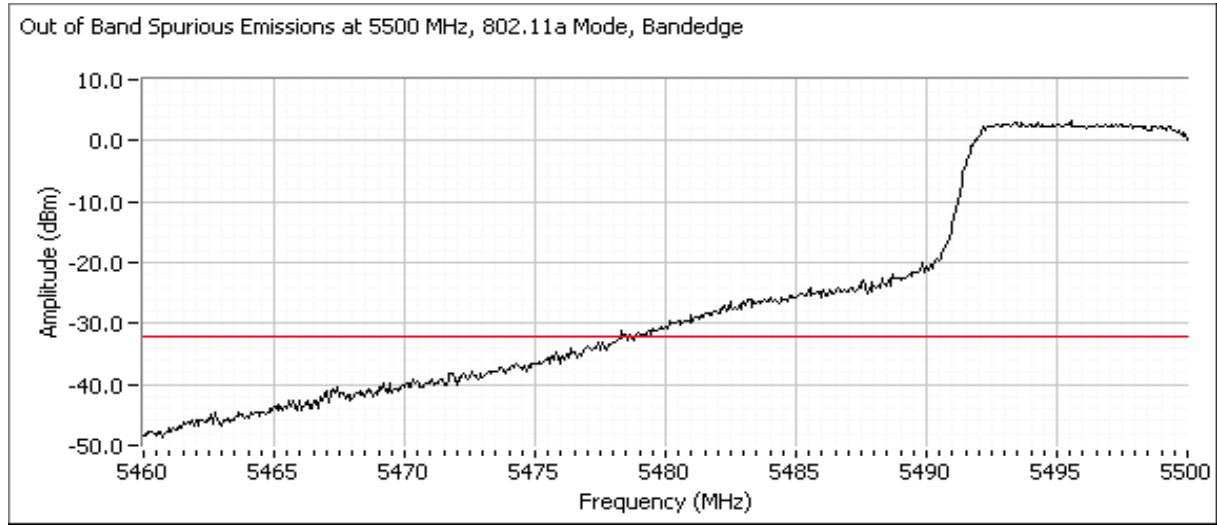

Center Channel, Chain A, 5600 MHz

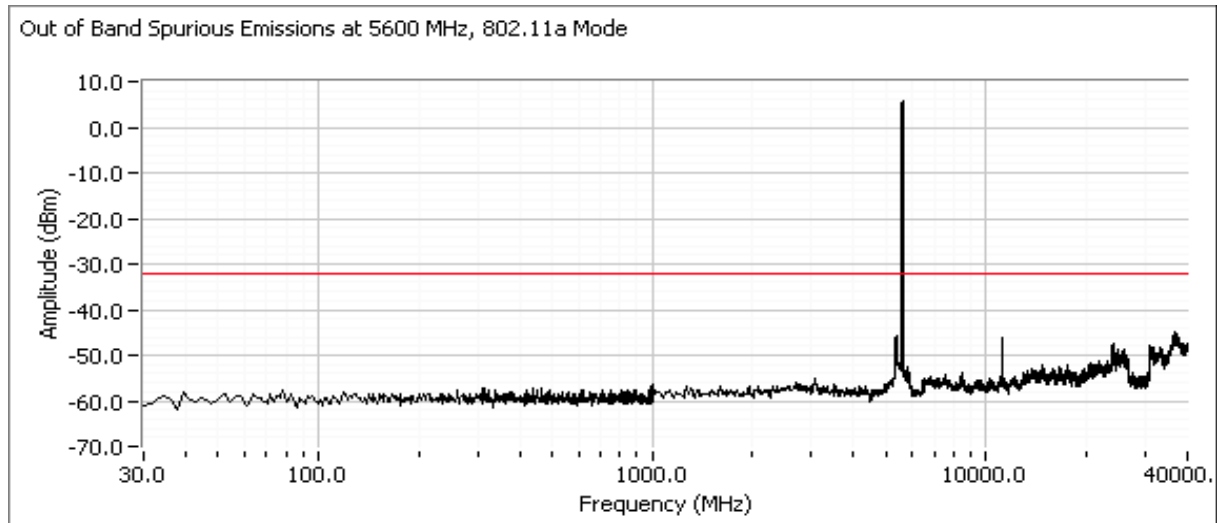

Client:	Intel	Job Number:	J70979
Model:	512-an MMW	T-Log Number:	T71037
Contact:	Robert Paxman	Account Manager:	Dean Eriksen
Standard:	FCC 15 E / RSS -210 (RF Port)	Class:	N/A

High Channel, Chain A, 5700 MHz - includes a second plot from 5700 - 5800 MHz, showing compliance with the limit immediately above the 5725 MHz band edge.

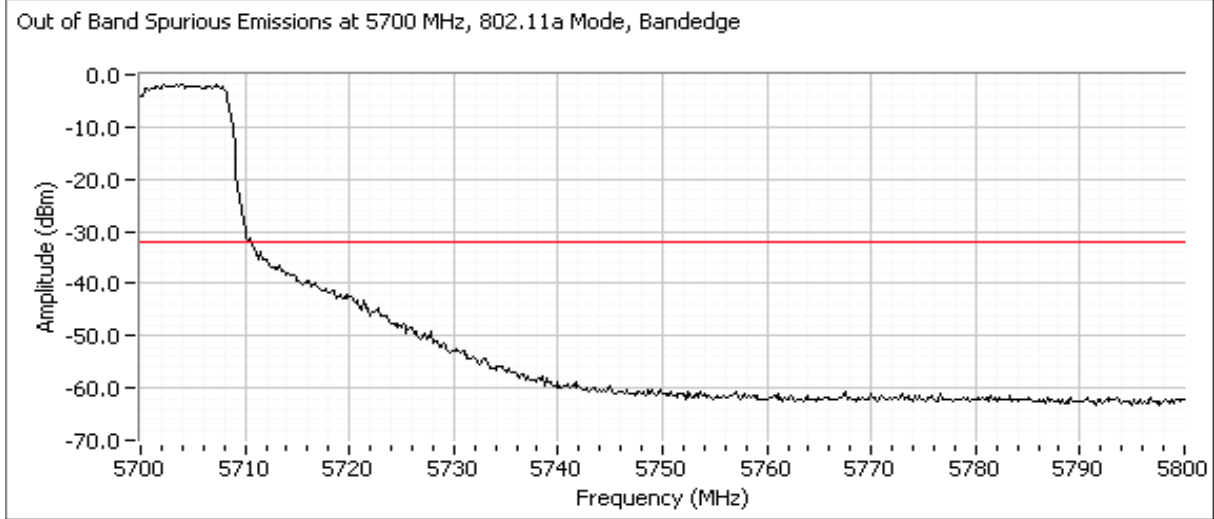
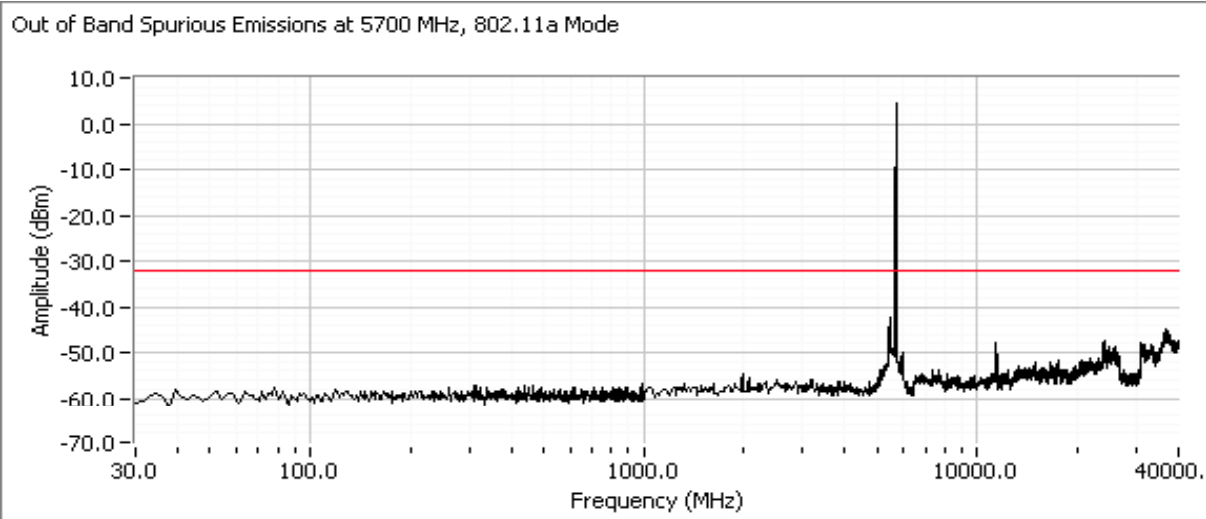

Client:	Intel	Job Number:	J70979
Model:	512-an MMW	T-Log Number:	T71037
		Account Manager:	Dean Eriksen
Contact:	Robert Paxman		
Standard:	FCC 15 E / RSS -210 (RF Port)	Class:	N/A

RSS-210 (LELAN) and FCC 15.407(UNII)
Antenna Port Measurements
Power, PSD, Peak Excursion, Bandwidth - Chain A, 802.11n 20MHz

Test Specific Details

Objective: The objective of this test session is to perform final qualification testing of the EUT with respect to the specification listed above.

Date of Test: 4/14/2008
 Test Engineer: Rafael Varelas
 Test Location: FT Lab #1

Config. Used: 1
 Config Change: None
 EUT Voltage: Powered from host

General Test Configuration

When measuring the conducted emissions from the EUT's antenna port, the antenna port of the EUT was connected to the spectrum analyzer or power meter via a suitable attenuator to prevent overloading the measurement system. All measurements are corrected to allow for the external attenuators and cables used.

Ambient Conditions: Temperature: 19.6 °C
 Rel. Humidity: 33 %

Summary of Results

Run #	Test Performed	Limit	Pass / Fail	Result / Margin
1	Power, 5150 - 5250MHz	15.407(a) (1), (2)	Pass	14.4 dBm (28mW)
1	Power, 5250 - 5350MHz	15.407(a) (1), (2)	Pass	13.6 dBm (23mW)
1	Power, 5470 - 5725MHz	15.407(a) (1), (2)	Pass	17.3 dBm (54mW)
1	PSD, 5150 - 5250MHz	15.407(a) (1), (2)	Pass	1.6 dBm/MHz
1	PSD, 5250 - 5350MHz	15.407(a) (1), (2)	Pass	0.8 dBm/MHz
1	PSD, 5470 - 5725MHz	15.407(a) (1), (2)	Pass	4.4 dBm/MHz
1	26dB Bandwidth	15.407	-	43.8 MHz
1	99% Bandwidth	RSS 210	-	18.4 MHz
2	Peak Excursion Envelope	15.407(a) (6)	Pass	10.5 dB

Modifications Made During Testing

No modifications were made to the EUT during testing

Deviations From The Standard

No deviations were made from the requirements of the standard.

Client:	Intel	Job Number:	J70979
Model:	512-an MMW	T-Log Number:	T71037
Contact:	Robert Paxman	Account Manager:	Dean Eriksen
Standard:	FCC 15 E / RSS -210 (RF Port)	Class:	N/A

Run #1: Bandwidth, Output Power and Power spectral Density

 Antenna Gain (dBi): 5

Frequency (MHz)	Software Setting	Bandwidth		Output Power ¹ dBm		Power (Watts)	PSD ² dBm/MHz			Result
		26dB	99% ⁴	Measured	Limit		Measured	FCC Limit	RSS Limit ³	
5180	28.5	26.8	18.1	14.4	17.0	0.028	1.6	4.0	5.0	Pass
5200	26.5	23.0	18.1	13.1	17.0	0.020	0.3	4.0	5.0	Pass
5240	25.5	23.1	18.1	12.8	17.0	0.019	0.0	4.0	5.0	Pass
5260	25.5	22.8	18.1	13.2	24.0	0.021	0.5	11.0	11.0	Pass
5280	24.5	22.6	18.1	12.6	24.0	0.018	-0.3	11.0	11.0	Pass
5320	25.0	23.8	18.2	13.6	24.0	0.023	0.8	11.0	11.0	Pass
5500	29.0	43.8	18.4	17.3	24.0	0.054	4.4	11.0	11.0	Pass
5600	25.5	23.3	18.2	13.3	24.0	0.021	0.5	11.0	11.0	Pass
5700	28.0	36.5	18.2	13.9	24.0	0.025	1.3	11.0	11.0	Pass

Note 1:	Output power measured using a spectrum analyzer (see plots below): RBW=1MHz, VB=3 MHz, sample detector, power averaging on (transmitted signal was continuous) and power integration over 50 MHz
Note 2:	Measured using the same analyzer settings used for output power.
Note 3:	For RSS-210 the limit for the 5150 - 5250 MHz band accounts for the antenna gain as the maximum eirp allowed is 10dBm/MHz. The limits are also corrected for instances where the highest measured value of the PSD exceeds the average PSD (calculated from the measured power divided by the measured 99% bandwidth) by more than 3dB by the amount that the measured value exceeds the average by more than 3dB.
Note 4:	99% Bandwidth measured in accordance with RSS GEN - RB > 1% of span and VB >=3xRB

Client: Intel	Job Number: J70979
Model: 512-an MMW	T-Log Number: T71037
Contact: Robert Paxman	Account Manager: Dean Eriksen
Standard: FCC 15 E / RSS -210 (RF Port)	Class: N/A

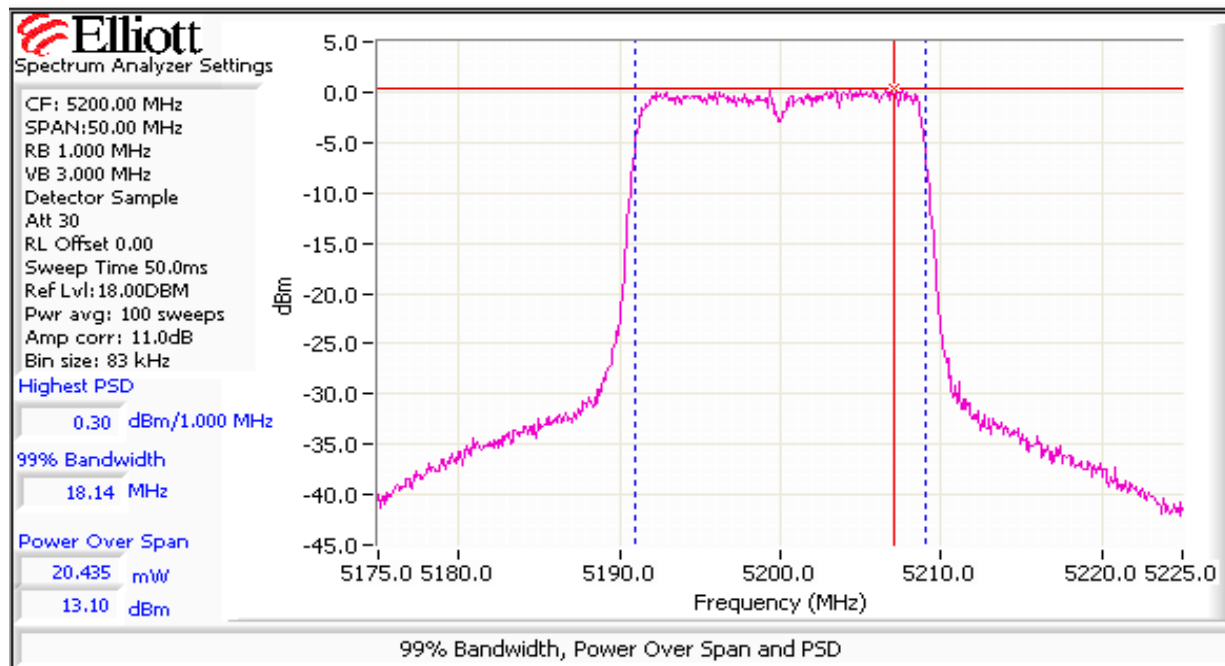
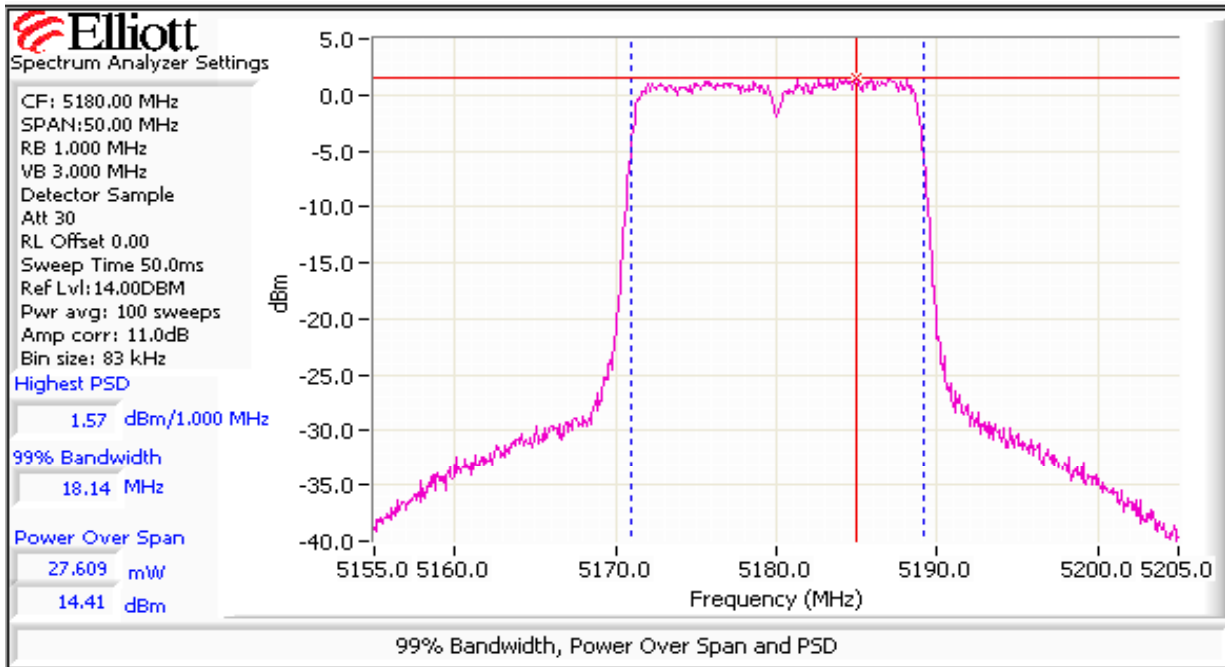

Client: Intel	Job Number: J70979
Model: 512-an MMW	T-Log Number: T71037
Contact: Robert Paxman	Account Manager: Dean Eriksen
Standard: FCC 15 E / RSS -210 (RF Port)	Class: N/A

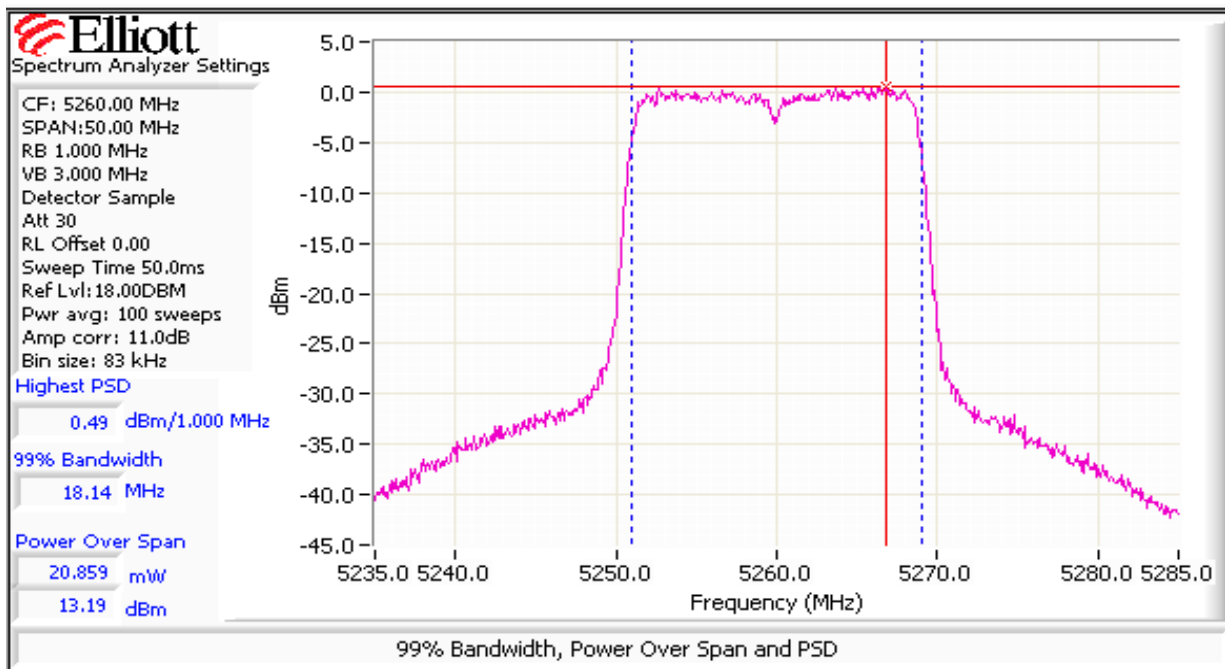
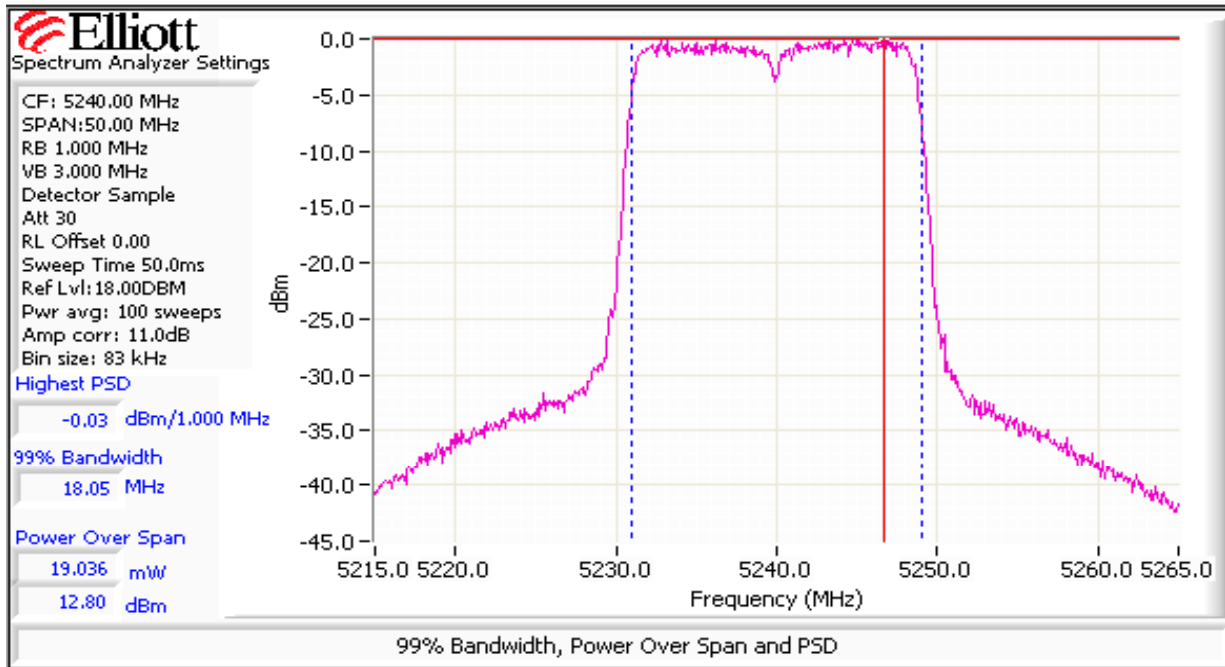

Client: Intel	Job Number: J70979
Model: 512-an MMW	T-Log Number: T71037
Contact: Robert Paxman	Account Manager: Dean Eriksen
Standard: FCC 15 E / RSS -210 (RF Port)	Class: N/A

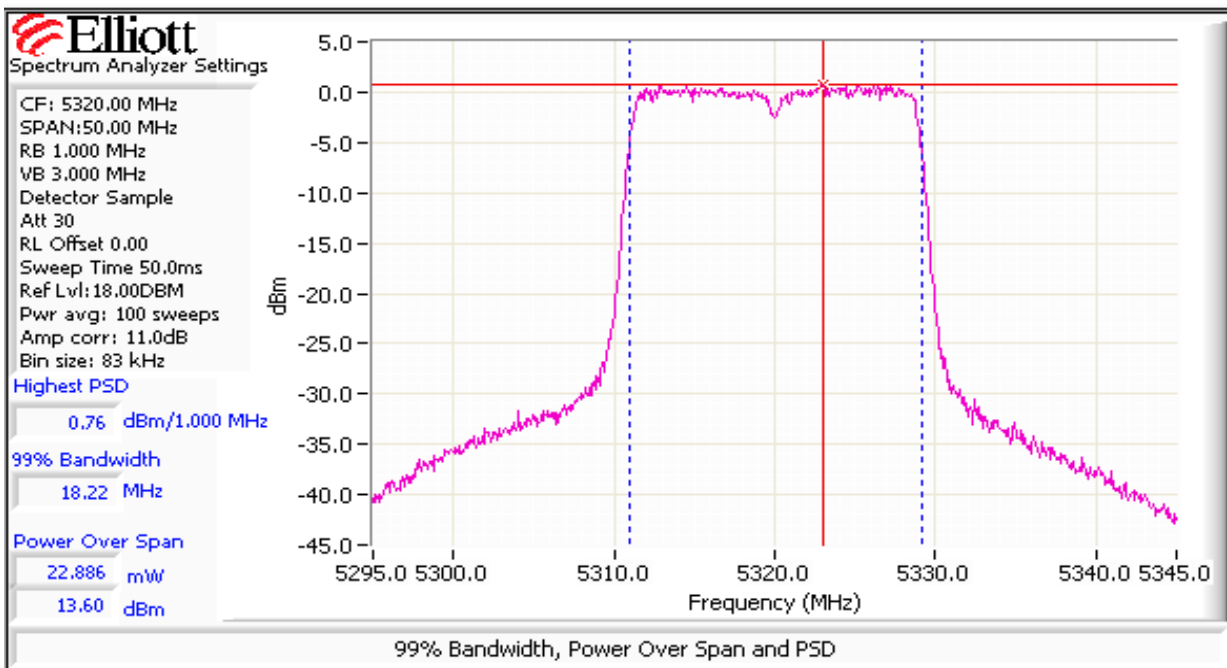
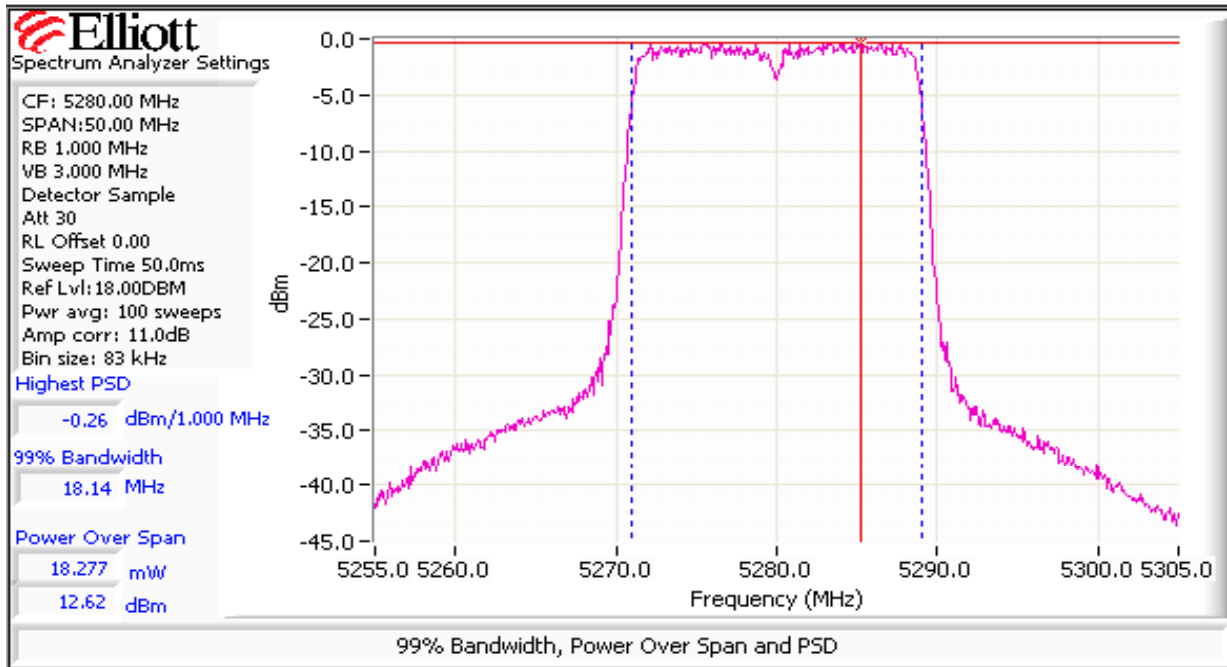

Client: Intel	Job Number: J70979
Model: 512-an MMW	T-Log Number: T71037
Contact: Robert Paxman	Account Manager: Dean Eriksen
Standard: FCC 15 E / RSS -210 (RF Port)	Class: N/A

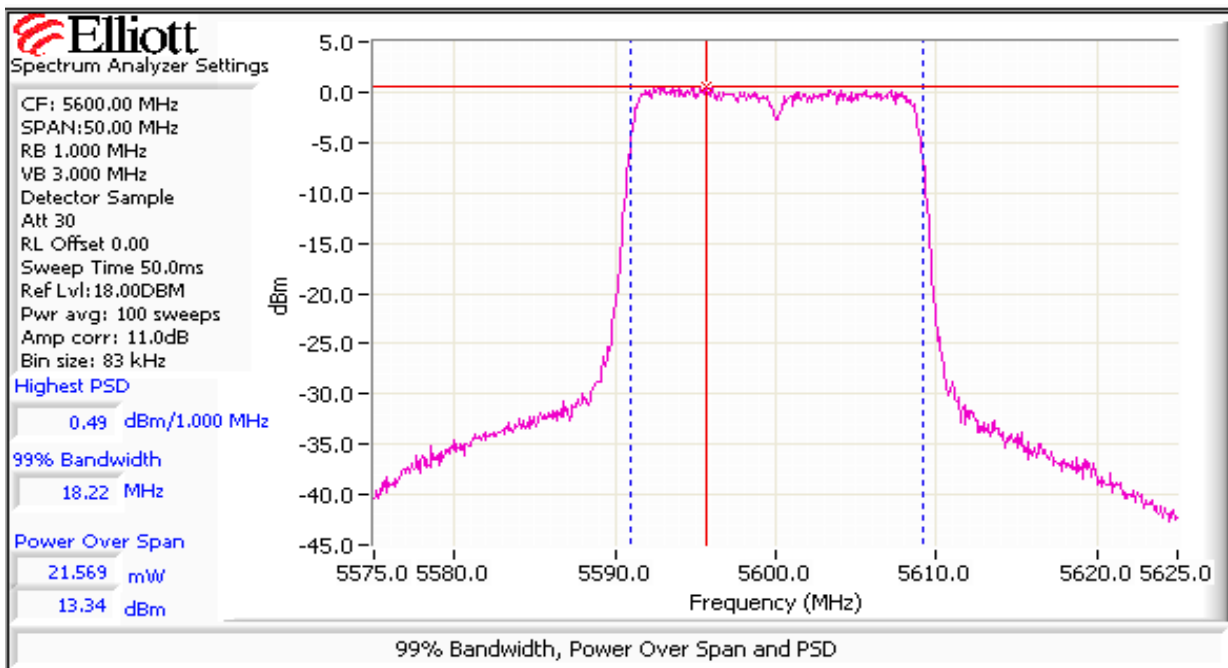
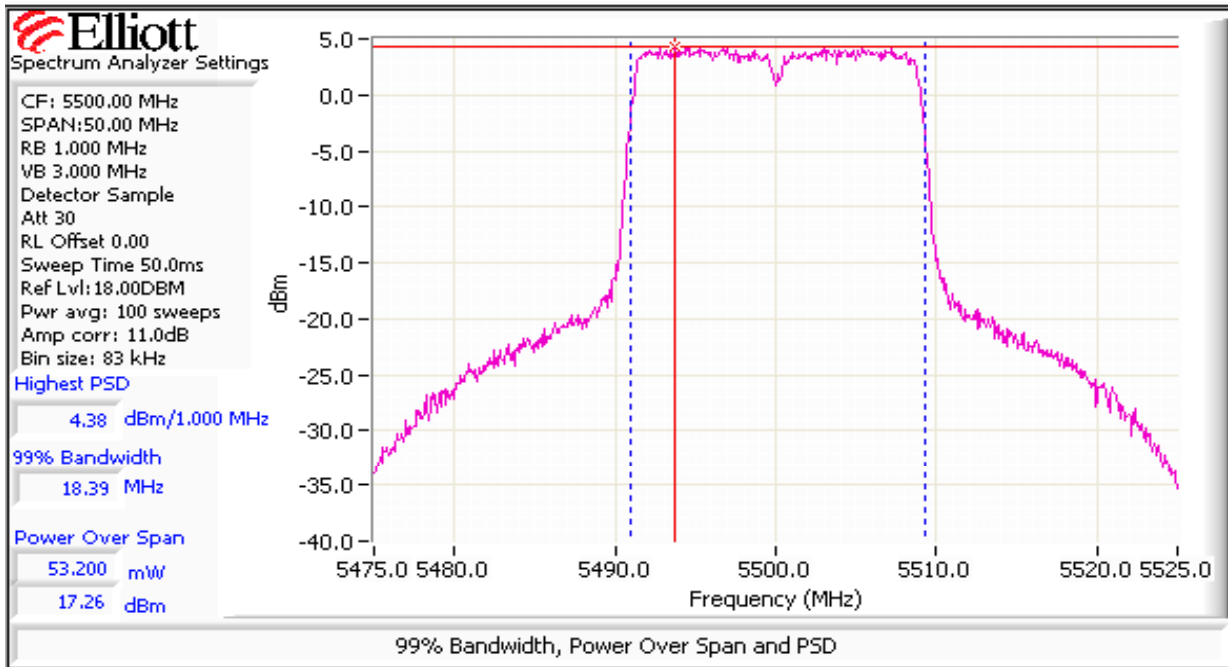

Client: Intel	Job Number: J70979
Model: 512-an MMW	T-Log Number: T71037
Contact: Robert Paxman	Account Manager: Dean Eriksen
Standard: FCC 15 E / RSS -210 (RF Port)	Class: N/A

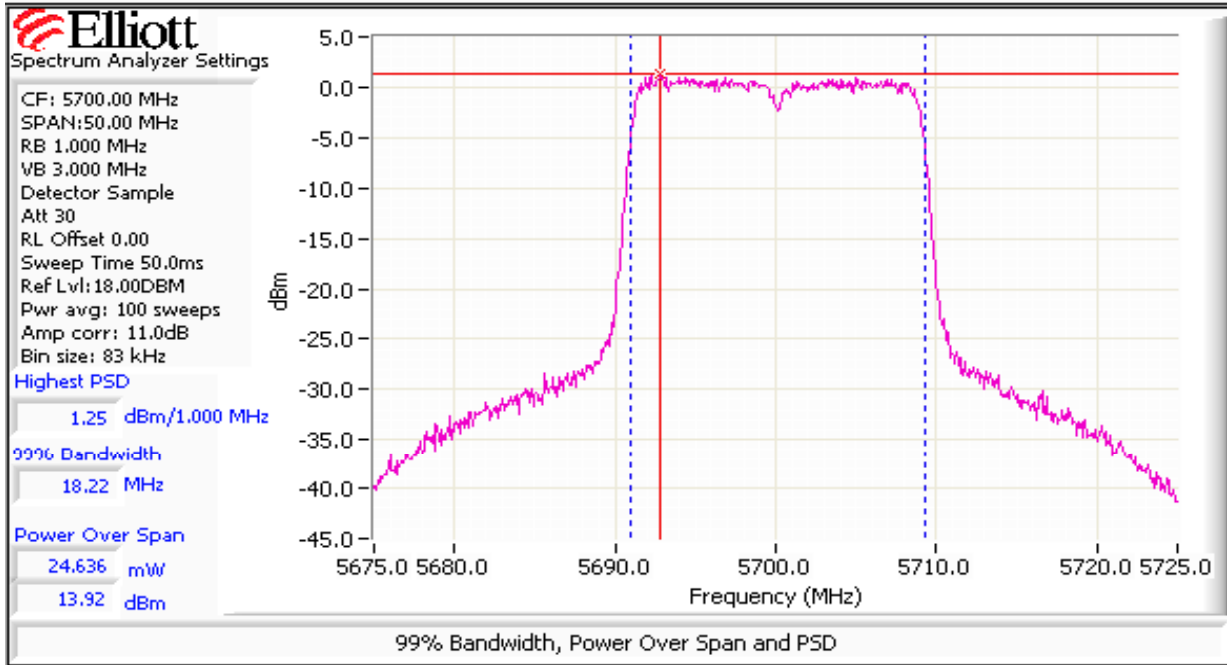

Run #2: Peak Excursion Measurement

Device meets the requirement for the peak excursion

Freq		Peak Excursion(dB)		Freq		Peak Excursion(dB)		
(MHz)	Value	Limit	(MHz)	Value	Limit	(MHz)	Value	Limit
5180	10.2	13.0	5260	10.1	13.0	5500	10.3	13.0
5200	10.5	13.0	5280	9.9	13.0	5600	10.2	13.0
5240	9.8	13.0	5320	9.9	13.0	5700	10.0	13.0

Plots Showing Peak Excursion

Trace A: RBW = VBW = 3MHz, Peak hold

Trace B: RBW = 1 MHz, VBW = 3MHz, Integrated average power

Client: Intel	Job Number: J70979
Model: 512-an MMW	T-Log Number: T71037
Contact: Robert Paxman	Account Manager: Dean Eriksen
Standard: FCC 15 E / RSS -210 (RF Port)	Class: N/A

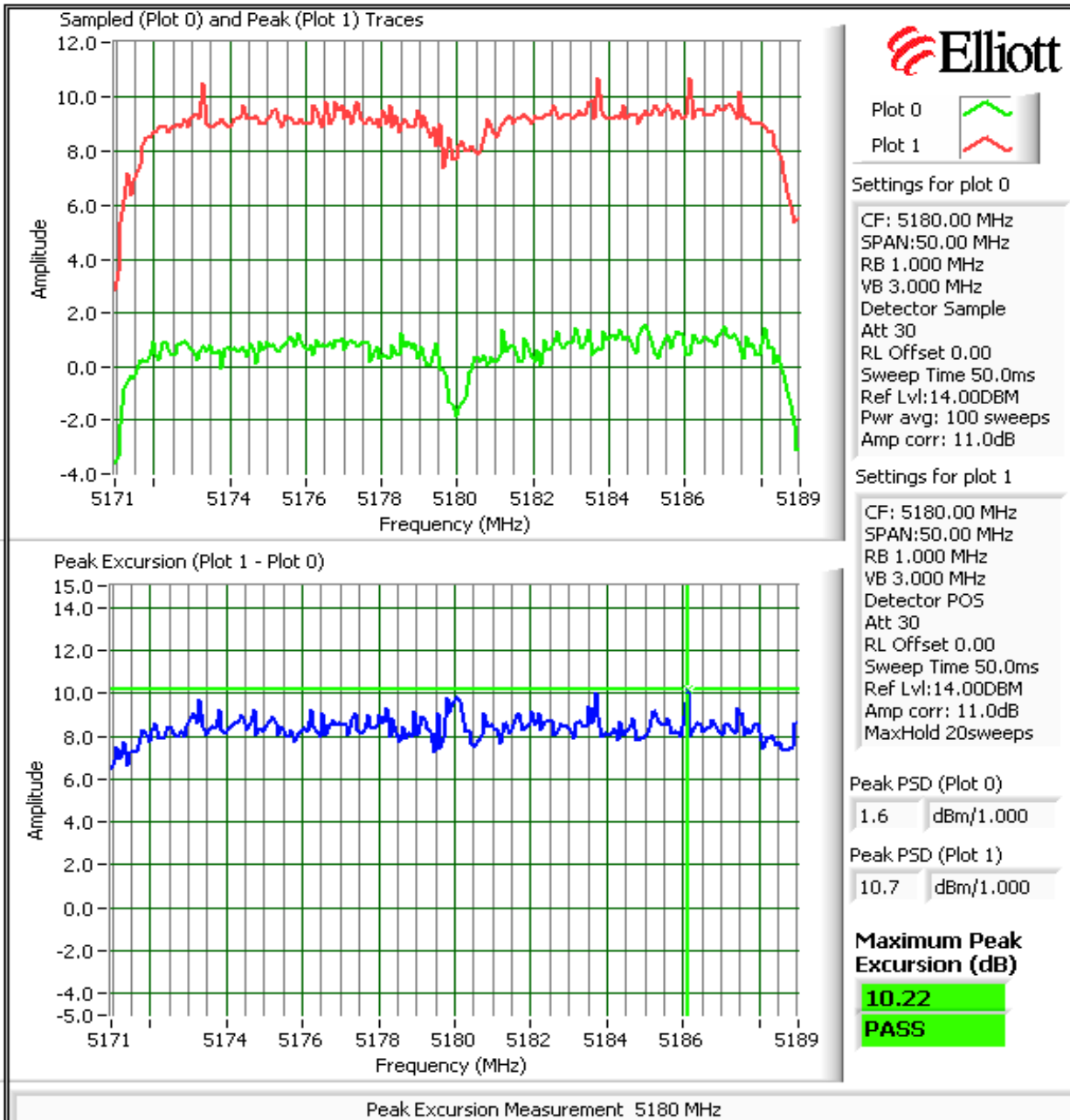

Client: Intel	Job Number: J70979
Model: 512-an MMW	T-Log Number: T71037
Contact: Robert Paxman	Account Manager: Dean Eriksen
Standard: FCC 15 E / RSS -210 (RF Port)	Class: N/A

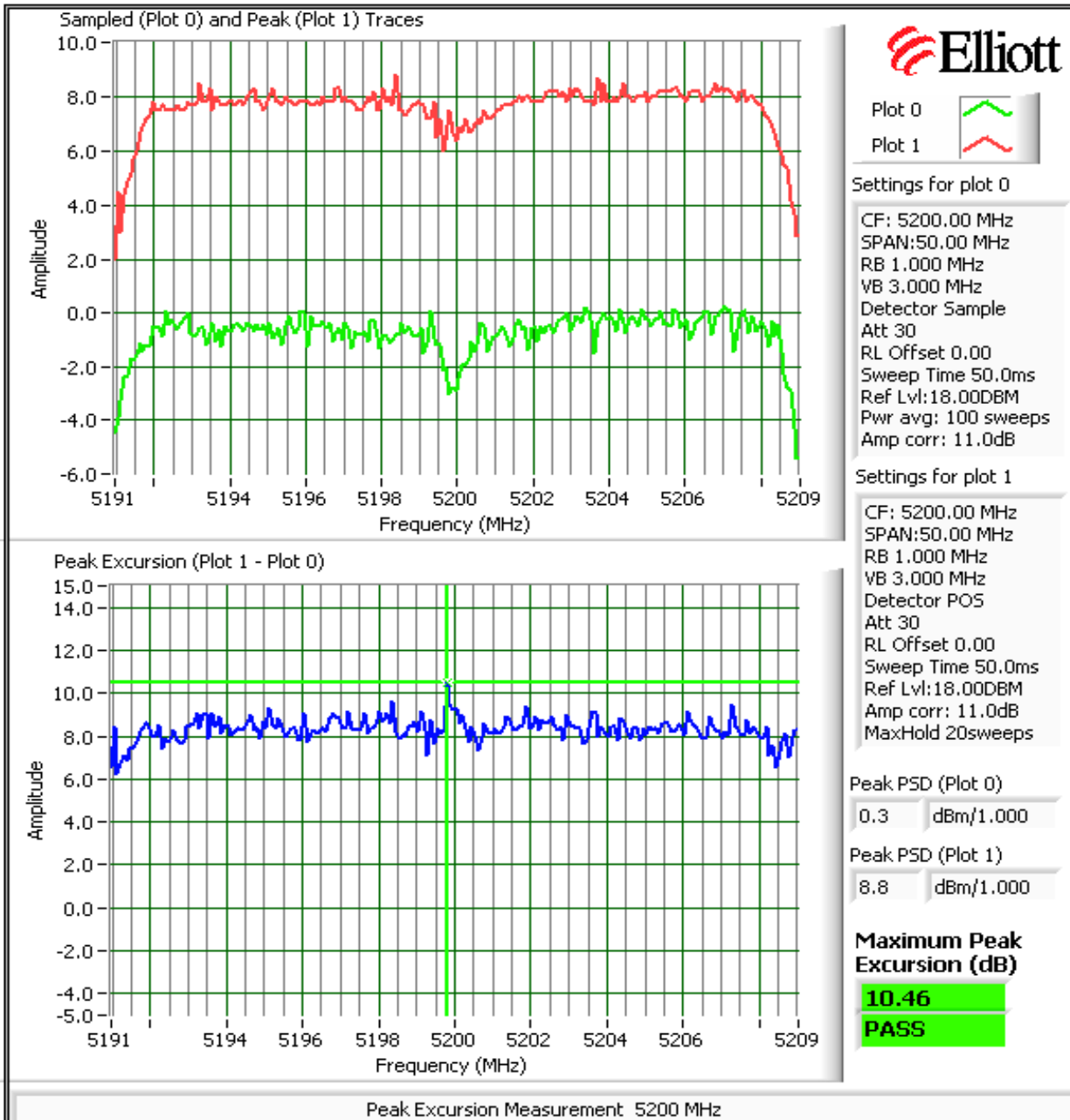

Client: Intel	Job Number: J70979
Model: 512-an MMW	T-Log Number: T71037
Contact: Robert Paxman	Account Manager: Dean Eriksen
Standard: FCC 15 E / RSS -210 (RF Port)	Class: N/A

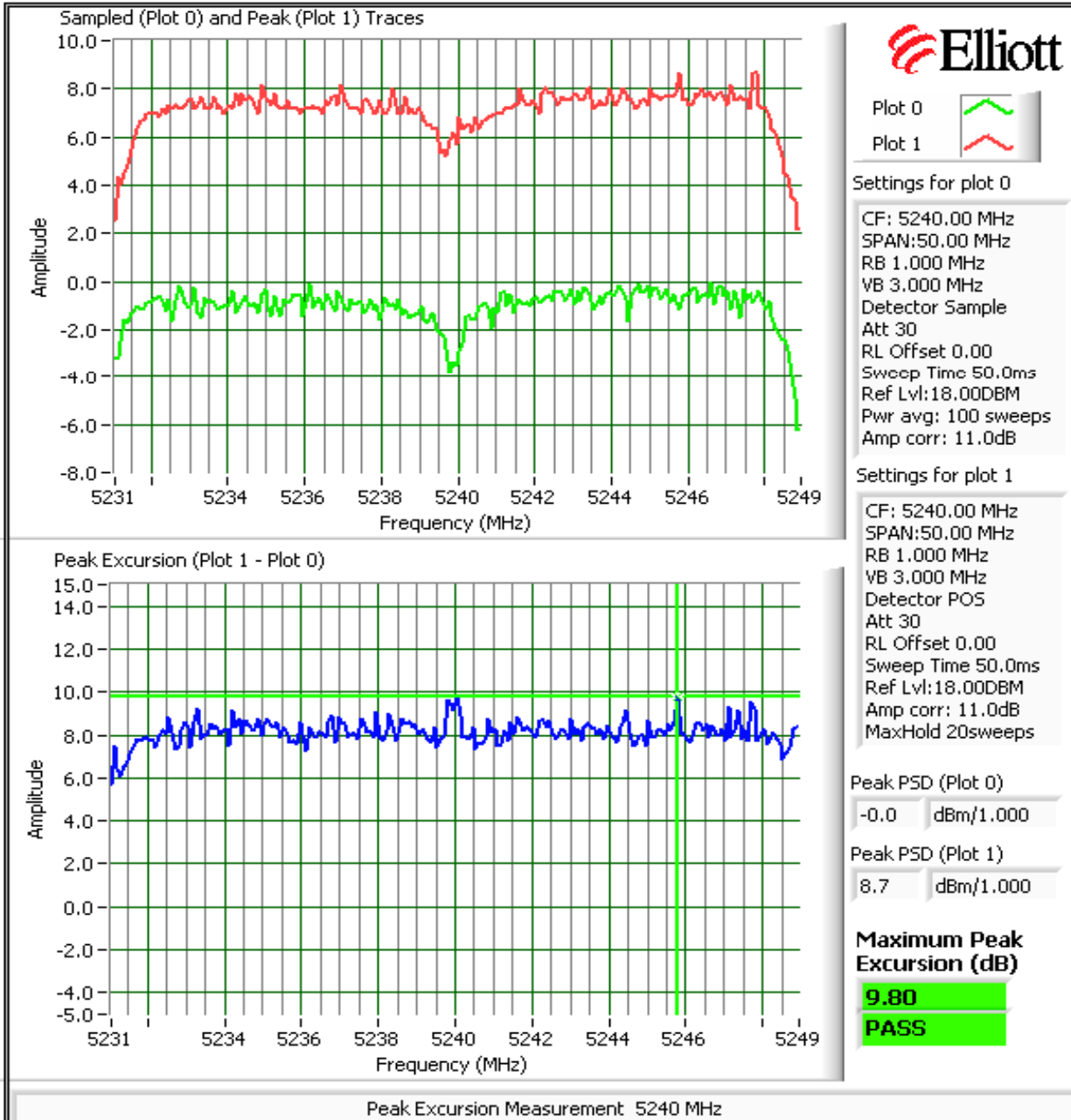

Client: Intel	Job Number: J70979
Model: 512-an MMW	T-Log Number: T71037
Contact: Robert Paxman	Account Manager: Dean Eriksen
Standard: FCC 15 E / RSS -210 (RF Port)	Class: N/A

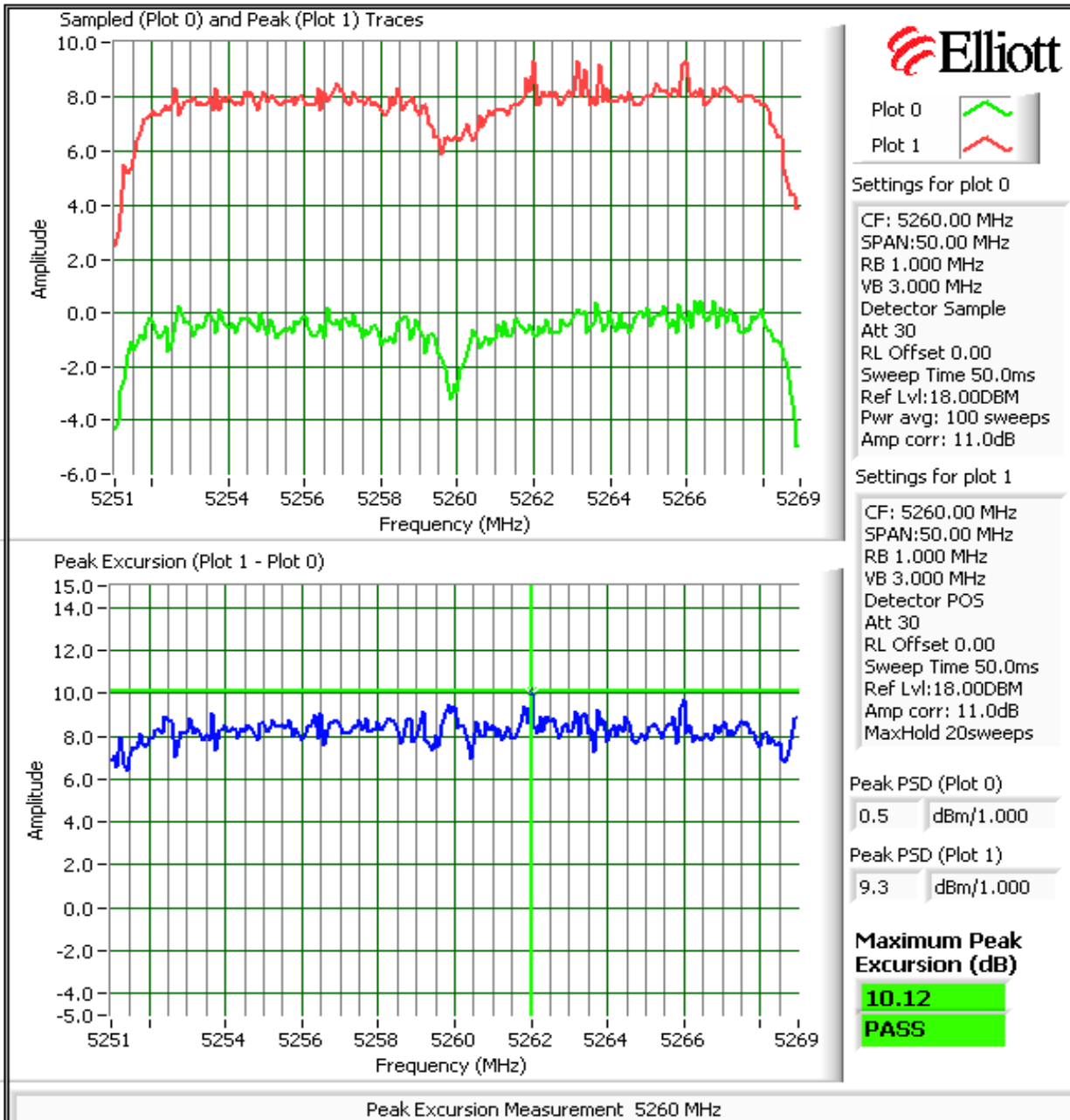

Client: Intel	Job Number: J70979
Model: 512-an MMW	T-Log Number: T71037
Contact: Robert Paxman	Account Manager: Dean Eriksen
Standard: FCC 15 E / RSS -210 (RF Port)	Class: N/A

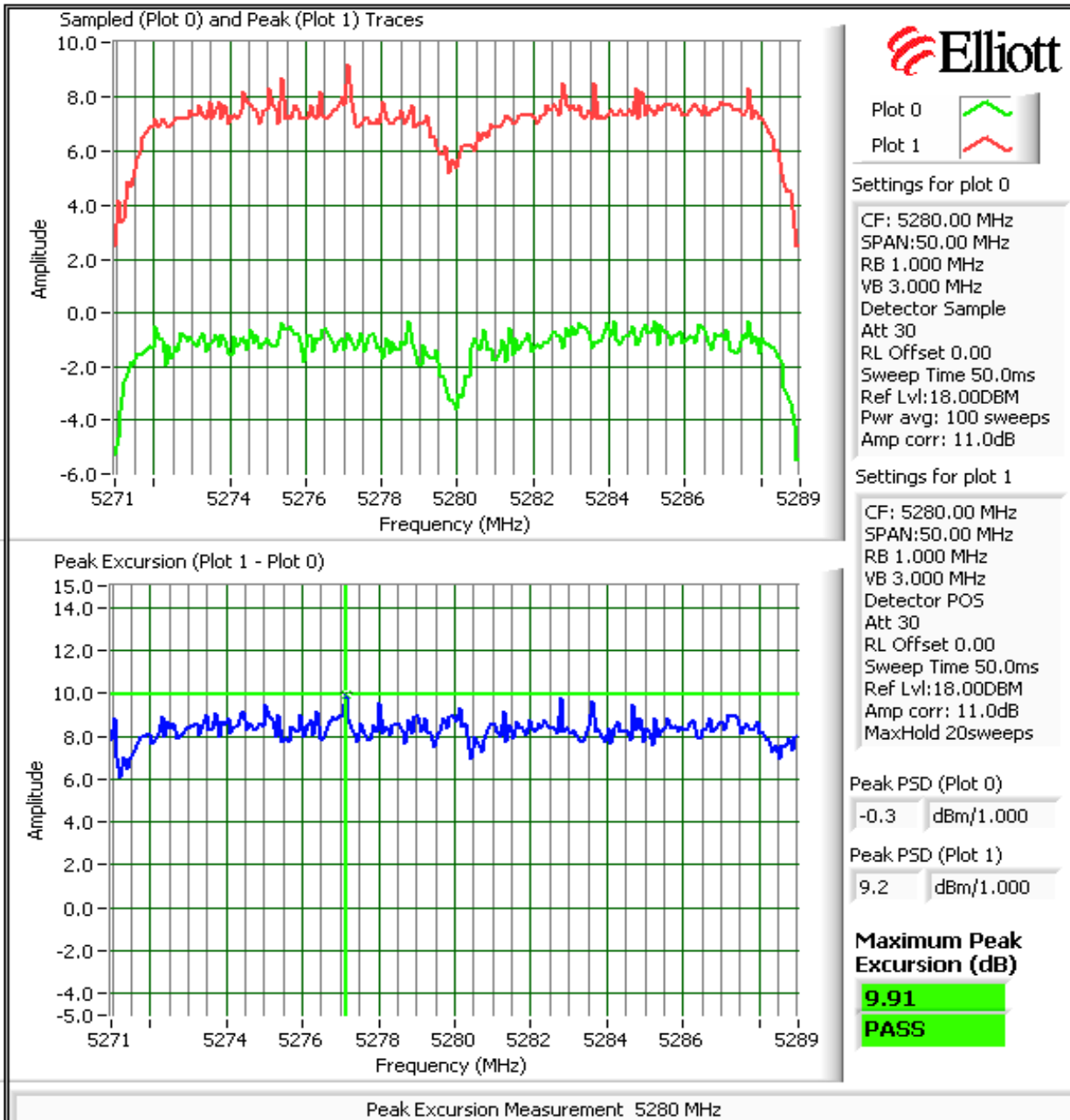

Client: Intel	Job Number: J70979
Model: 512-an MMW	T-Log Number: T71037
Contact: Robert Paxman	Account Manager: Dean Eriksen
Standard: FCC 15 E / RSS -210 (RF Port)	Class: N/A

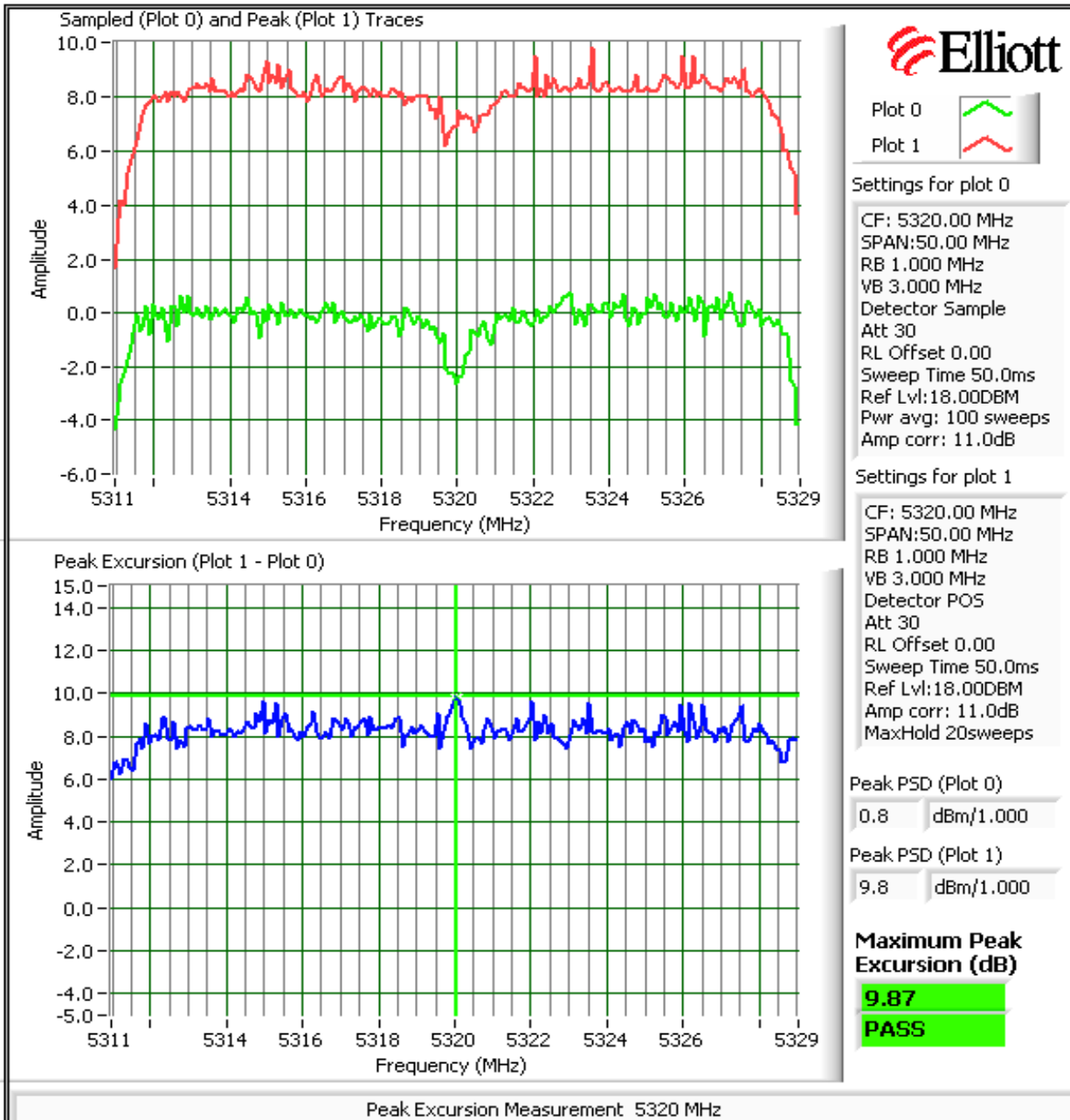

Client: Intel	Job Number: J70979
Model: 512-an MMW	T-Log Number: T71037
Contact: Robert Paxman	Account Manager: Dean Eriksen
Standard: FCC 15 E / RSS -210 (RF Port)	Class: N/A

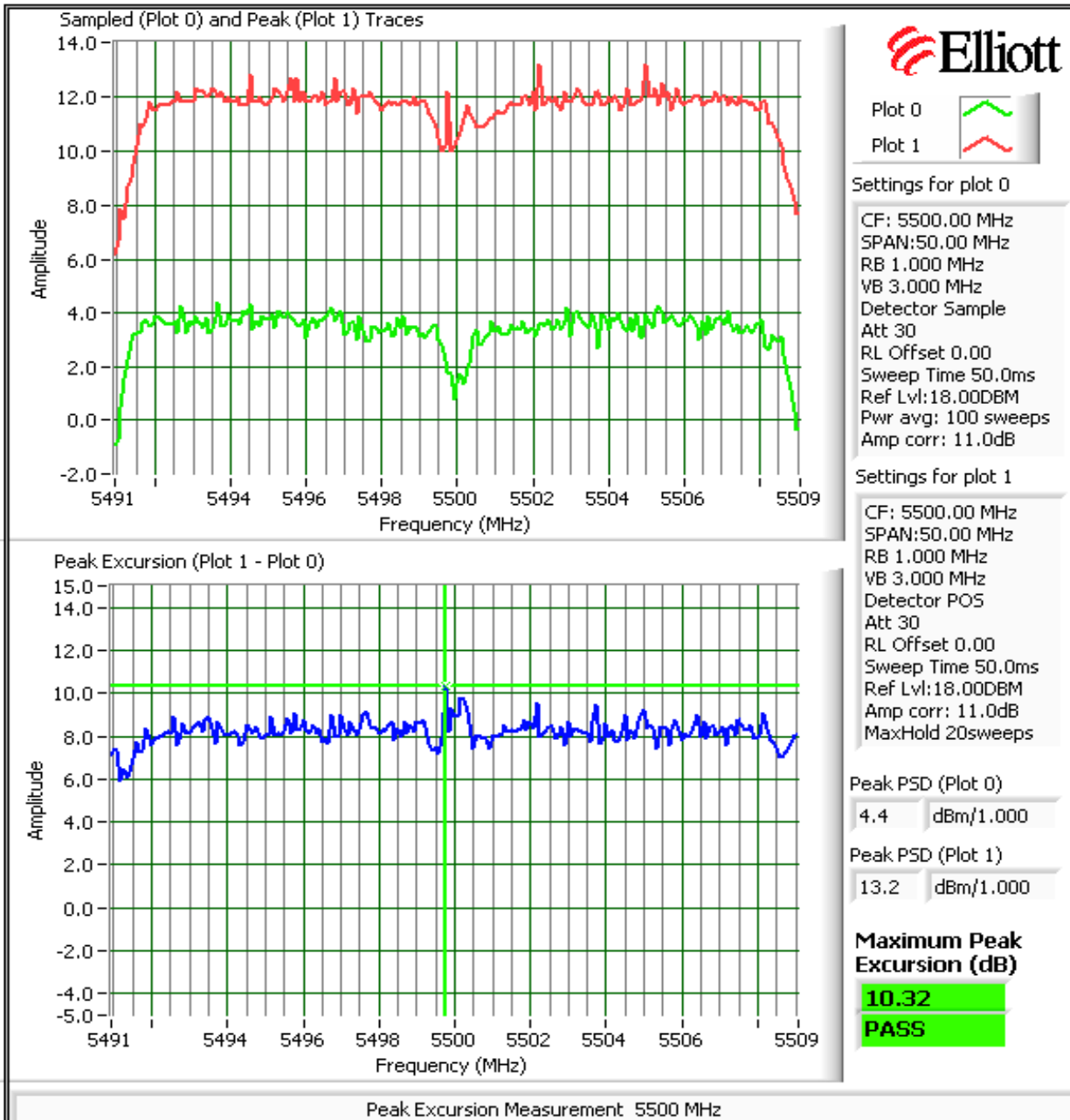

Client: Intel	Job Number: J70979
Model: 512-an MMW	T-Log Number: T71037
Contact: Robert Paxman	Account Manager: Dean Eriksen
Standard: FCC 15 E / RSS -210 (RF Port)	Class: N/A

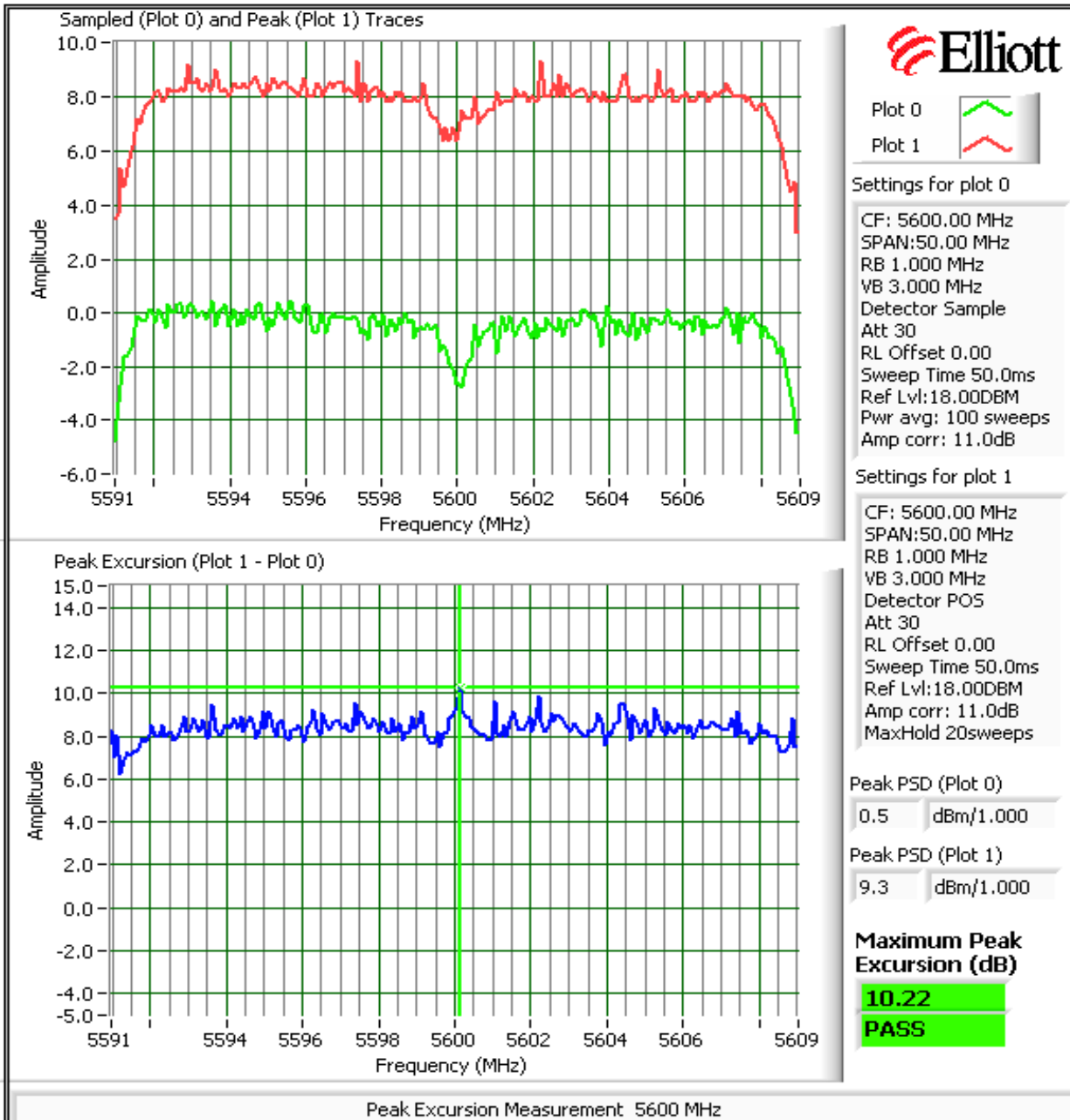

Client: Intel	Job Number: J70979
Model: 512-an MMW	T-Log Number: T71037
Contact: Robert Paxman	Account Manager: Dean Eriksen
Standard: FCC 15 E / RSS -210 (RF Port)	Class: N/A

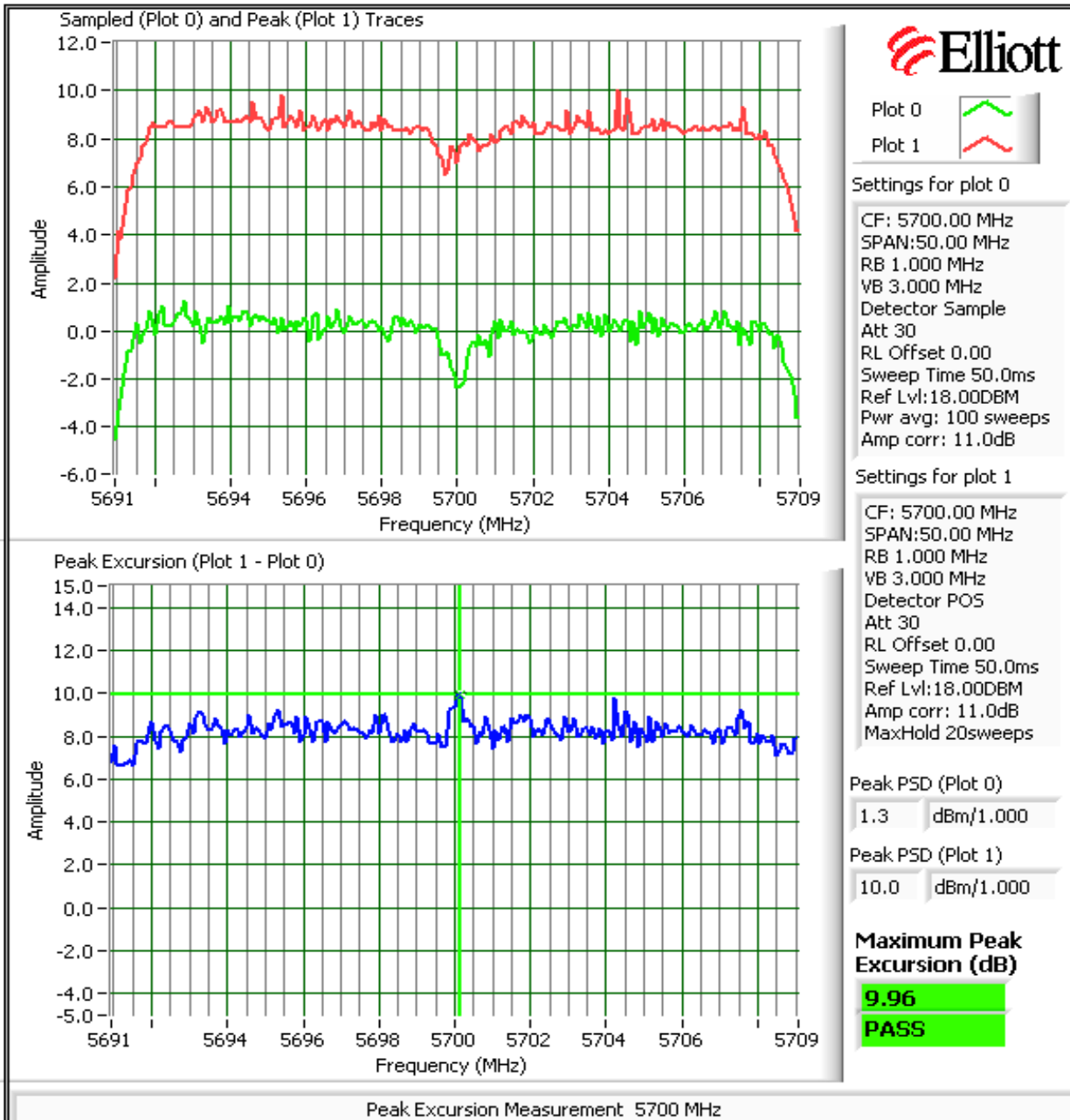

Client:	Intel	Job Number:	J70979
Model:	512-an MMW	T-Log Number:	T71037
		Account Manager:	Dean Eriksen
Contact:	Robert Paxman		
Standard:	FCC 15 E / RSS -210 (RF Port)	Class:	N/A

RSS-210 (LELAN) and FCC 15.407(UNII)
Antenna Port Measurements
Spurious Emissions - 802.11n 20MHz

Test Specific Details

Objective: The objective of this test session is to perform final qualification testing of the EUT with respect to the specification listed above.

Date of Test: 4/14/2008
 Test Engineer: Rafael Varelas
 Test Location: FT Lab #1

Config. Used: 1
 Config Change: None
 EUT Voltage: Powered from host

General Test Configuration

When measuring the conducted emissions from the EUT's antenna port, the antenna port of the EUT was connected to the spectrum analyzer or power meter via a suitable attenuator to prevent overloading the measurement system. All measurements are corrected to allow for the external attenuators and cables used.

Ambient Conditions: Temperature: 19.6 °C
 Rel. Humidity: 33 %

Summary of Results

Run #	Test Performed	Limit	Pass / Fail	Result / Margin
1	Antenna Conducted - Out of Band Spurious, 802.11n-20MHz	15.407(b)	Pass	All emissions below the -27dBm/MHz limit

Modifications Made During Testing

No modifications were made to the EUT during testing

Deviations From The Standard

No deviations were made from the requirements of the standard.

Client: Intel	Job Number: J70979
Model: 512-an MMW	T-Log Number: T71037
Contact: Robert Paxman	Account Manager: Dean Eriksen
Standard: FCC 15 E / RSS -210 (RF Port)	Class: N/A

Run #1: Out Of Band Spurious Emissions - Antenna Conducted, 20MHz 802.11n

The plots were obtained on each of the individual chains separately. The limit of -27dBm has been corrected to account for the antenna gain.

Maximum Antenna Gain:	5.0 dBi	
Spurious Limit:	-27.0 dBm/MHz eirp	
Correction for multiple chains transmitting:	0.0 dBm/MHz eirp	(No MIMO modes)
Limit Used On Plots ^{Note 1} :	-32.0 dBm/MHz	

Note 1: The -27dBm/MHz limit is an eirp limit. The limit for antenna port conducted measurements is adjusted to take into consideration the maximum antenna gain (limit = -27dBm - antenna gain) plus the total number of chains transmitting simultaneously. Radiated field strength measurements for signals more than 50MHz from the bands that are close to the limit are made to determine compliance as the antenna gain is not known at these frequencies.

Note 2: All spurious signals below 1GHz are measured during digital device radiated emissions test.

Note 3: Signals that fall in the restricted bands of 15.205 are subject to the limit of 15.209.

Low Channel, Chain A, 5180 MHz

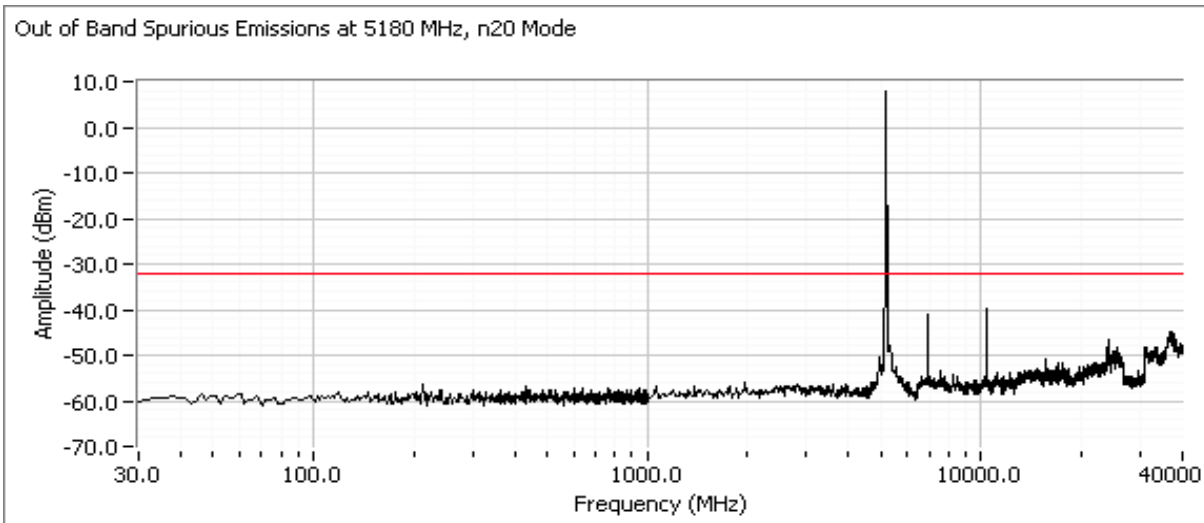

Client: Intel	Job Number: J70979
Model: 512-an MMW	T-Log Number: T71037
Contact: Robert Paxman	Account Manager: Dean Eriksen
Standard: FCC 15 E / RSS -210 (RF Port)	Class: N/A

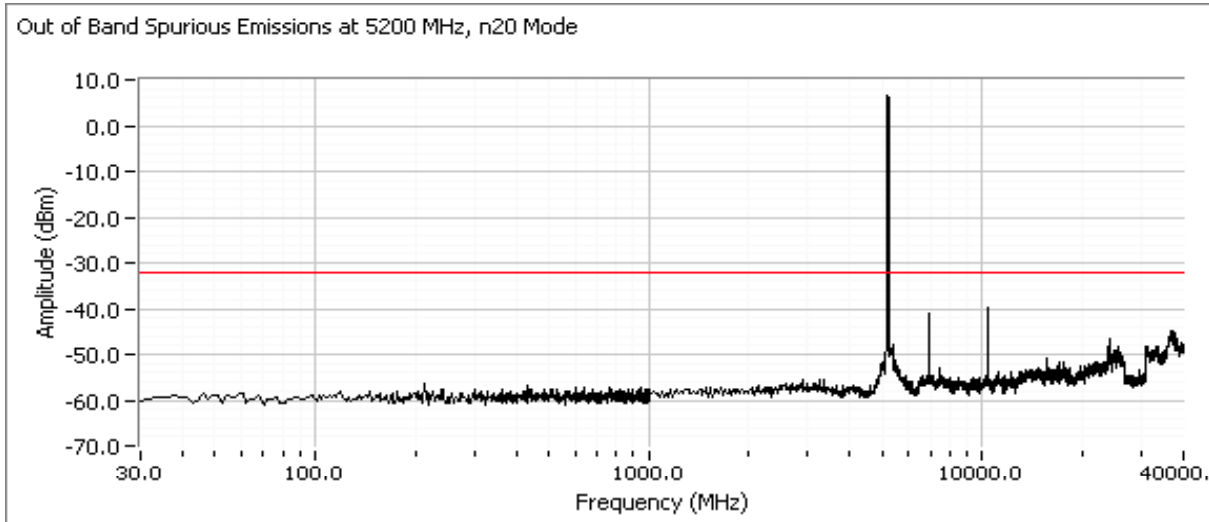
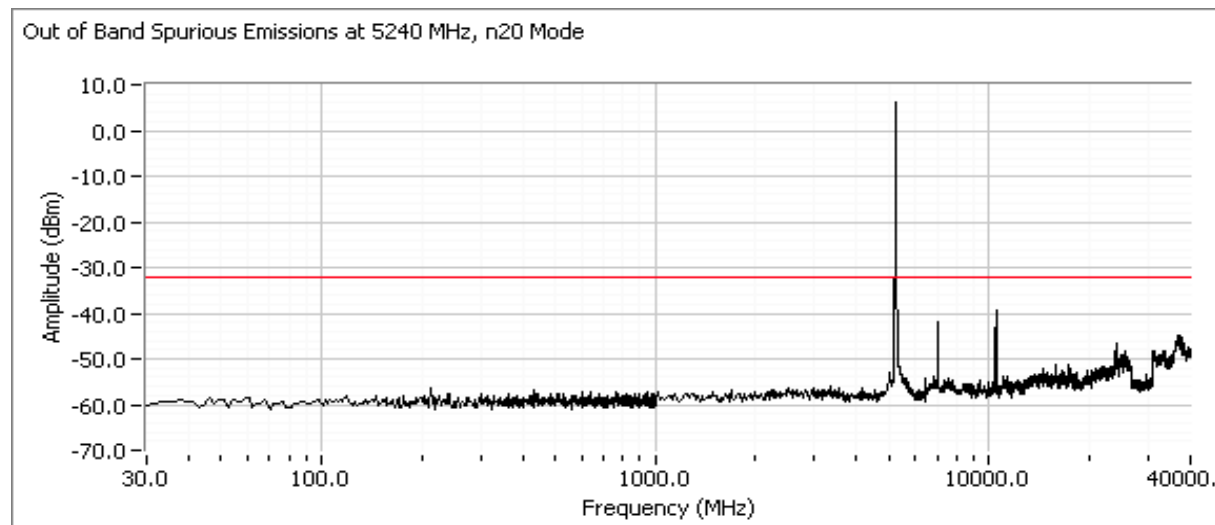
Center Channel, Chain A, 5200 MHz

High Channel, Chain A, 5240 MHz

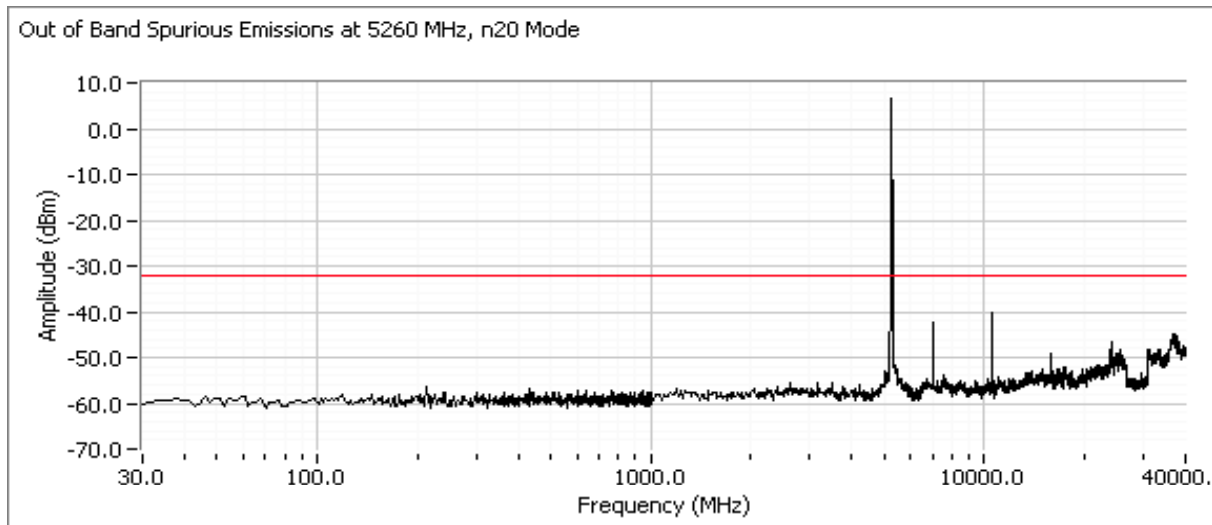
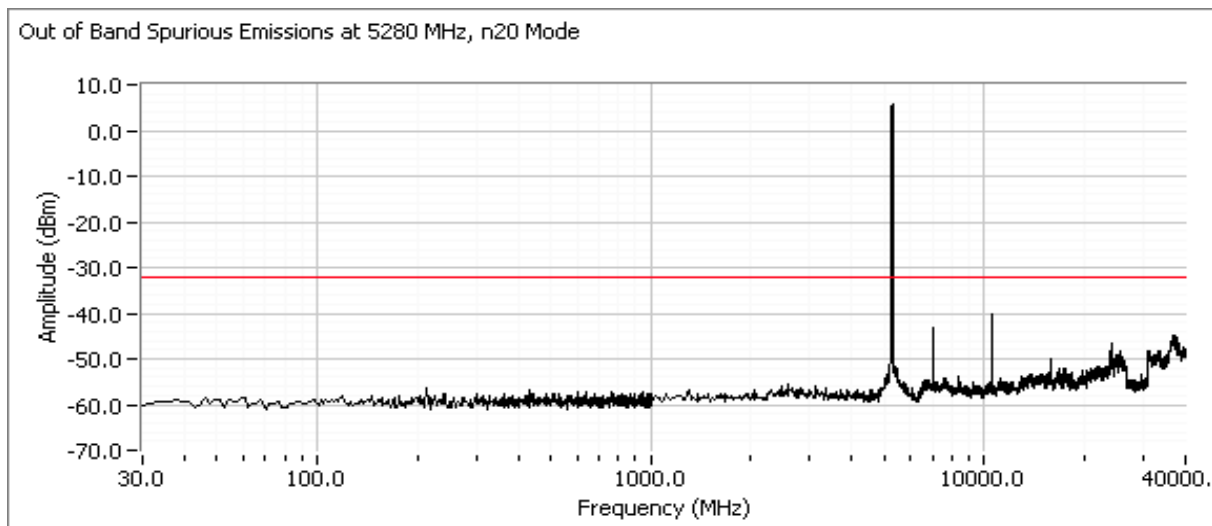
Client: Intel	Job Number: J70979
Model: 512-an MMW	T-Log Number: T71037
Contact: Robert Paxman	Account Manager: Dean Eriksen
Standard: FCC 15 E / RSS -210 (RF Port)	Class: N/A

Low Channel, Chain A, 5260 MHz

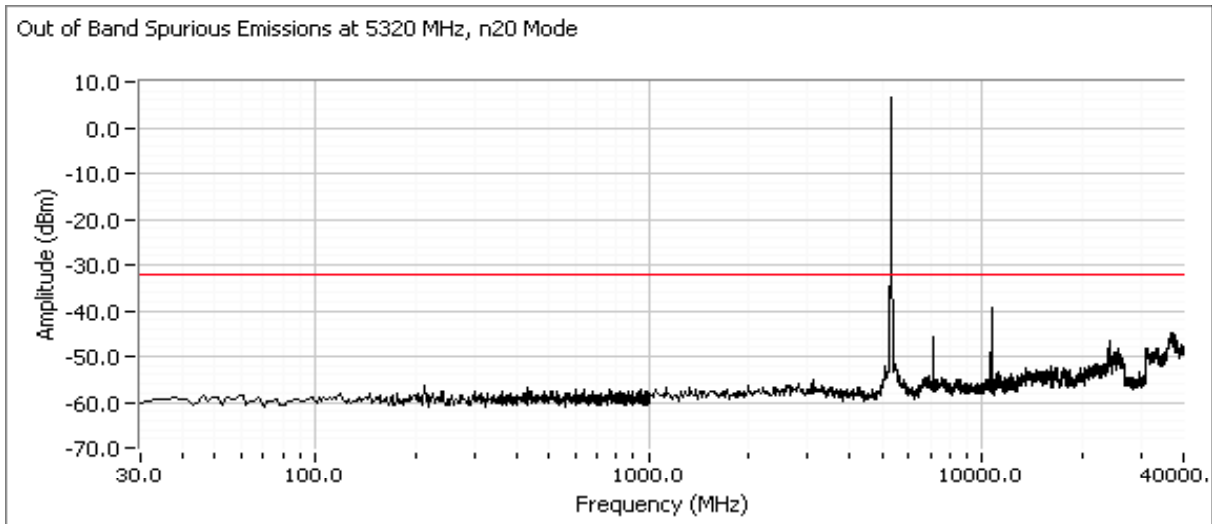
Center Channel, Chain A, 5280 MHz

Client: Intel	Job Number: J70979
Model: 512-an MMW	T-Log Number: T71037
Contact: Robert Paxman	Account Manager: Dean Eriksen
Standard: FCC 15 E / RSS -210 (RF Port)	Class: N/A

High Channel, Chain A, 5320 MHz

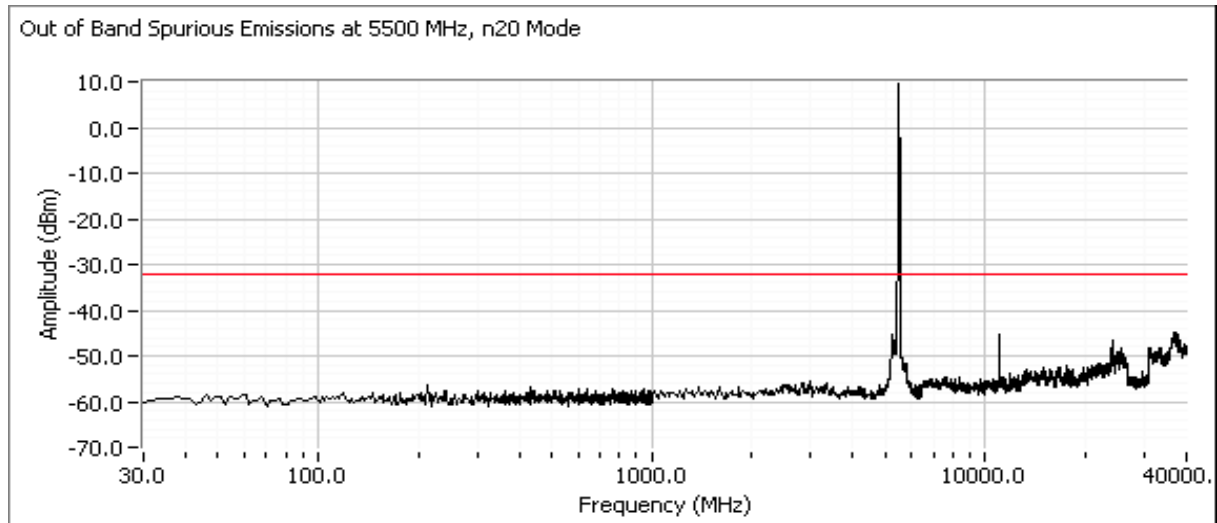
Low Channel, Chain A, 5500 MHz - includes a second plot from 5460 - 5500 MHz, showing compliance with the limit from 5460 - 5470 MHz. Compliance at the 5460 MHz restricted band edge is demonstrated via radiated measurements.



Client: Intel	Job Number: J70979
Model: 512-an MMW	T-Log Number: T71037
Contact: Robert Paxman	Account Manager: Dean Eriksen
Standard: FCC 15 E / RSS -210 (RF Port)	Class: N/A

Out of Band Spurious Emissions at 5500 MHz, n20 Mode, Bandedge

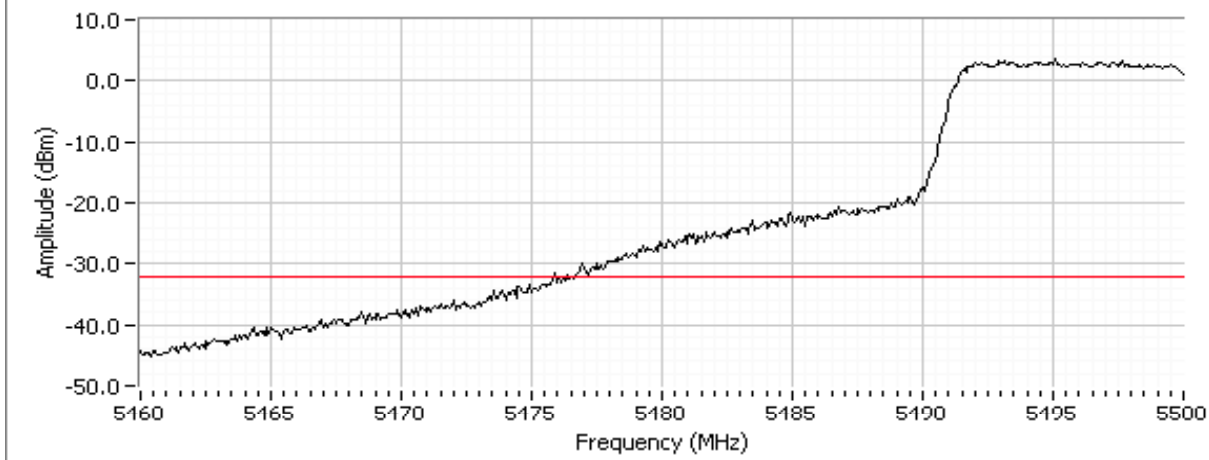

Center Channel, Chain A, 5600 MHz

Out of Band Spurious Emissions at 5600 MHz, n20 Mode

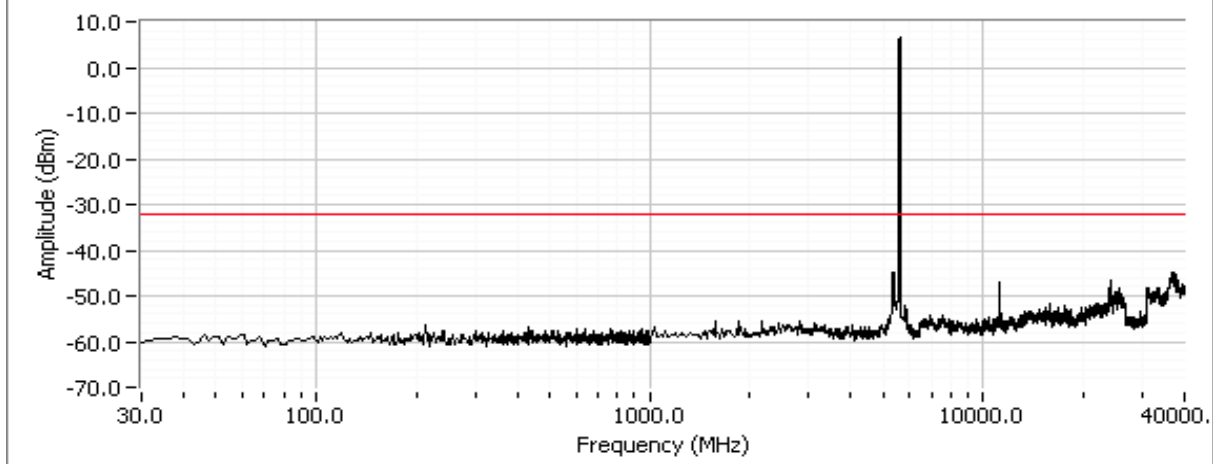

Client: Intel	Job Number: J70979
Model: 512-an MMW	T-Log Number: T71037
Contact: Robert Paxman	Account Manager: Dean Eriksen
Standard: FCC 15 E / RSS -210 (RF Port)	Class: N/A

High Channel, Chain A, 5700 MHz - includes a second plot from 5700 - 5800 MHz, showing compliance with the limit immediately above the 5725 MHz band edge.

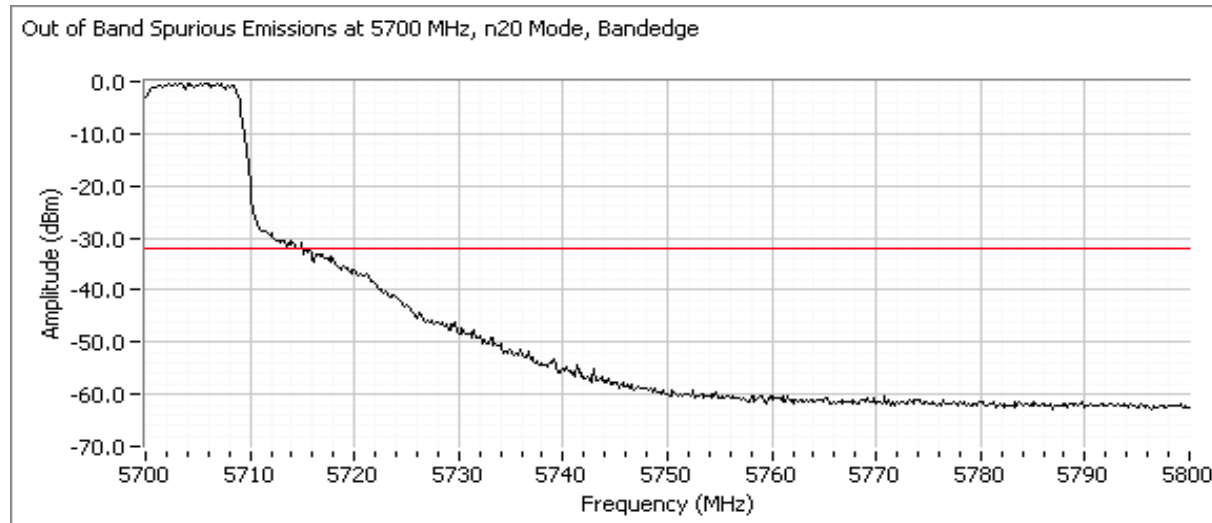
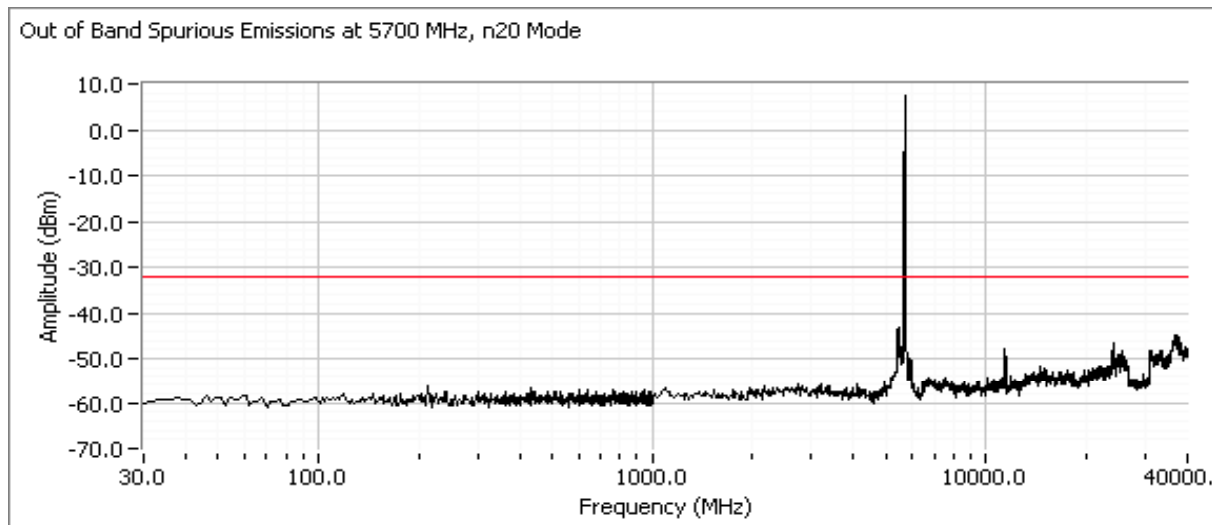

Client:	Intel	Job Number:	J70979
Model:	512-an MMW	T-Log Number:	T71037
		Account Manager:	Dean Eriksen
Contact:	Robert Paxman		
Standard:	FCC 15 E / RSS -210 (RF Port)	Class:	N/A

RSS-210 (LELAN) and FCC 15.407(UNII)
Antenna Port Measurements
Power, PSD, Peak Excursion, Bandwidth - Chain A, 802.11n 40MHz

Test Specific Details

Objective: The objective of this test session is to perform final qualification testing of the EUT with respect to the specification listed above.

Date of Test: 4/14/2008
 Test Engineer: Rafael Varelas
 Test Location: FT Lab #1

Config. Used: 1
 Config Change: None
 EUT Voltage: Powered from host

General Test Configuration

When measuring the conducted emissions from the EUT's antenna port, the antenna port of the EUT was connected to the spectrum analyzer or power meter via a suitable attenuator to prevent overloading the measurement system. All measurements are corrected to allow for the external attenuators and cables used.

Ambient Conditions: Temperature: 19.6 °C
 Rel. Humidity: 33 %

Summary of Results

Run #	Test Performed	Limit	Pass / Fail	Result / Margin
1	Power, 5150 - 5250MHz	15.407(a) (1), (2)	Pass	13.7 dBm (23mW)
1	Power, 5250 - 5350MHz	15.407(a) (1), (2)	Pass	13.9 dBm (25mW)
1	Power, 5470 - 5725MHz	15.407(a) (1), (2)	Pass	13.9 dBm (25mW)
1	PSD, 5150 - 5250MHz	15.407(a) (1), (2)	Pass	-1.3 dBm/MHz
1	PSD, 5250 - 5350MHz	15.407(a) (1), (2)	Pass	-1.2 dBm/MHz
1	PSD, 5470 - 5725MHz	15.407(a) (1), (2)	Pass	-1.5 dBm/MHz
1	26dB Bandwidth	15.407	-	51.2 MHz
1	99% Bandwidth	RSS 210	-	36.4 MHz
2	Peak Excursion Envelope	15.407(a) (6)		12.4 dB

Modifications Made During Testing

No modifications were made to the EUT during testing

Deviations From The Standard

No deviations were made from the requirements of the standard.

Client:	Intel	Job Number:	J70979
Model:	512-an MMW	T-Log Number:	T71037
		Account Manager:	Dean Eriksen
Contact:	Robert Paxman		
Standard:	FCC 15 E / RSS -210 (RF Port)	Class:	N/A

Run #1: Bandwidth, Output Power and Power spectral Density

 Antenna Gain (dBi): 5

Frequency (MHz)	Software Setting	Bandwidth		Output Power ¹ dBm		Power (Watts)	PSD ² dBm/MHz			Result
		26dB	99% ⁴	Measured	Limit		Measured	FCC Limit	RSS Limit ³	
5190	26.0	40.8	36.3	12.9	17.0	0.019	-2.1	4.0	5.0	Pass
5230	26.0	43.8	36.1	13.7	17.0	0.023	-1.3	4.0	5.0	Pass
5270	25.5	42.0	36.1	13.9	24.0	0.025	-1.2	11.0	11.0	Pass
5310	24.0	40.2	36.3	13.2	24.0	0.021	-2.0	11.0	11.0	Pass
5510	23.5	41.7	36.3	13.4	24.0	0.022	-1.8	11.0	11.0	Pass
5590	23.0	40.8	36.3	12.0	24.0	0.016	-3.3	11.0	11.0	Pass
5670	26.5	51.2	36.4	13.9	24.0	0.025	-1.5	11.0	11.0	Pass

Note 1:	Output power measured using a peak power meter Output power measured using a spectrum analyzer (see plots below): RBW=1MHz, VB=3 MHz, sample detector, power averaging on (transmitted signal was continuous) and power integration over 50 MHz
Note 2:	Measured using the same analyzer settings used for output power.
Note 3:	For RSS-210 the limit for the 5150 - 5250 MHz band accounts for the antenna gain as the maximum eirp allowed is 10dBm/MHz. The limits are also corrected for instances where the highest measured value of the PSD exceeds the average PSD (calculated from the measured power divided by the measured 99% bandwidth) by more than 3dB by the amount that the measured value exceeds the average by more than 3dB.
Note 4:	99% Bandwidth measured in accordance with RSS GEN - RB > 1% of span and VB >=3xRB

Client: Intel	Job Number: J70979
Model: 512-an MMW	T-Log Number: T71037
Contact: Robert Paxman	Account Manager: Dean Eriksen
Standard: FCC 15 E / RSS -210 (RF Port)	Class: N/A

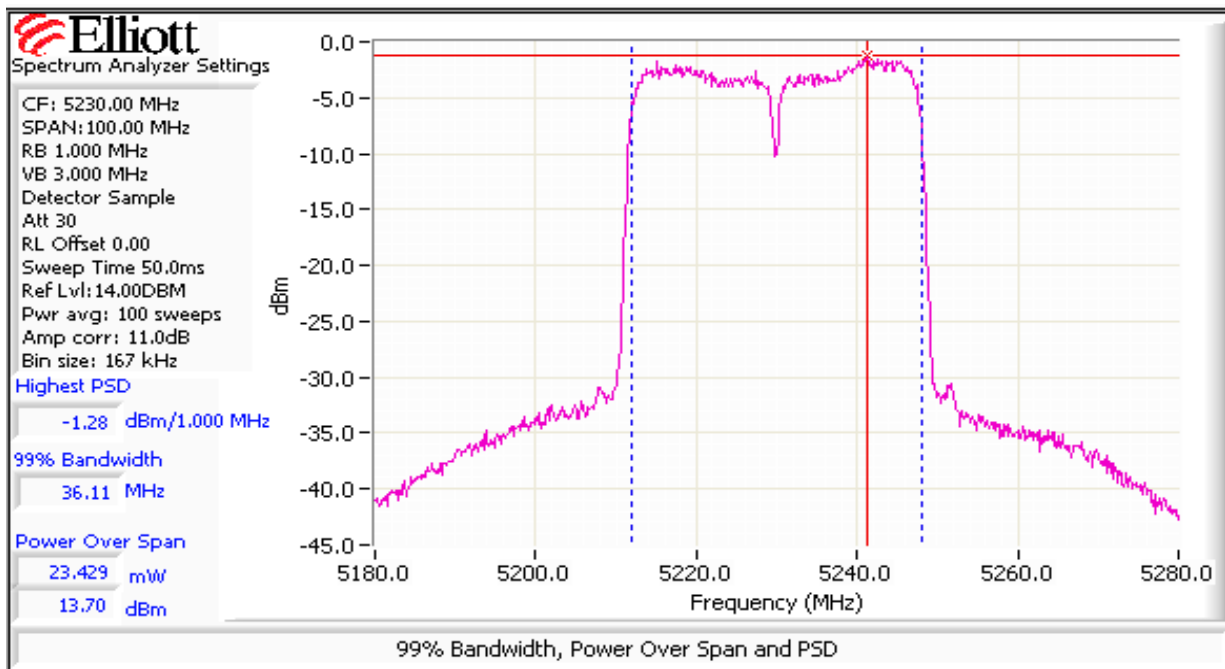
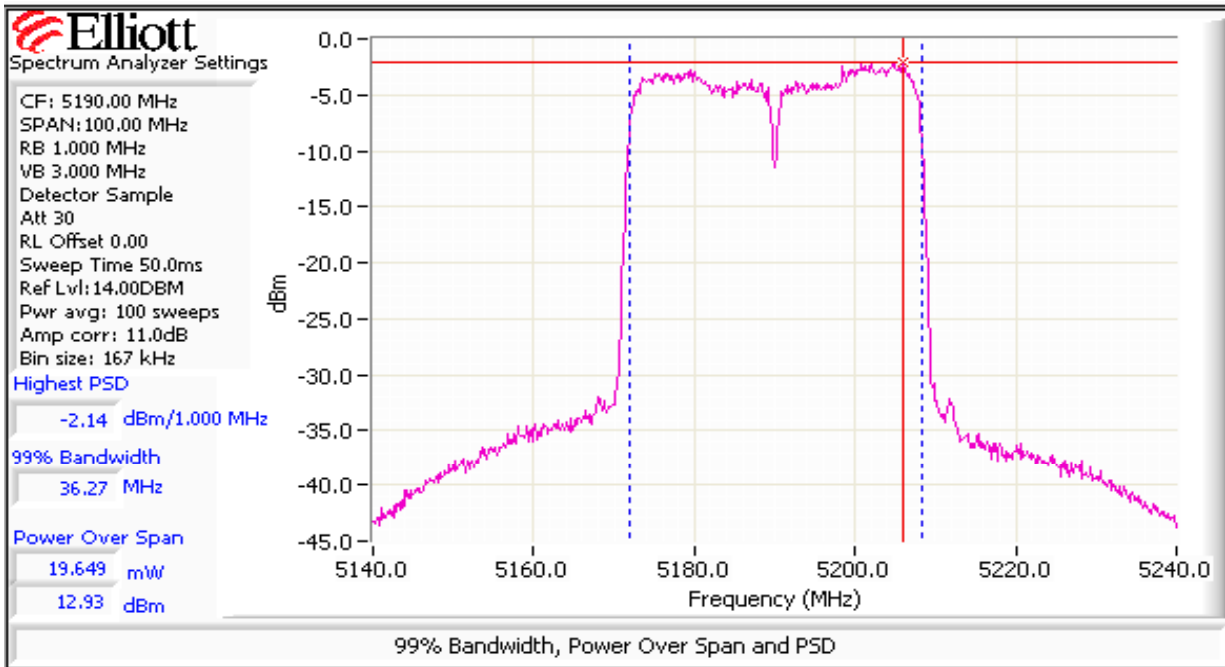

Client: Intel	Job Number: J70979
Model: 512-an MMW	T-Log Number: T71037
Contact: Robert Paxman	Account Manager: Dean Eriksen
Standard: FCC 15 E / RSS -210 (RF Port)	Class: N/A

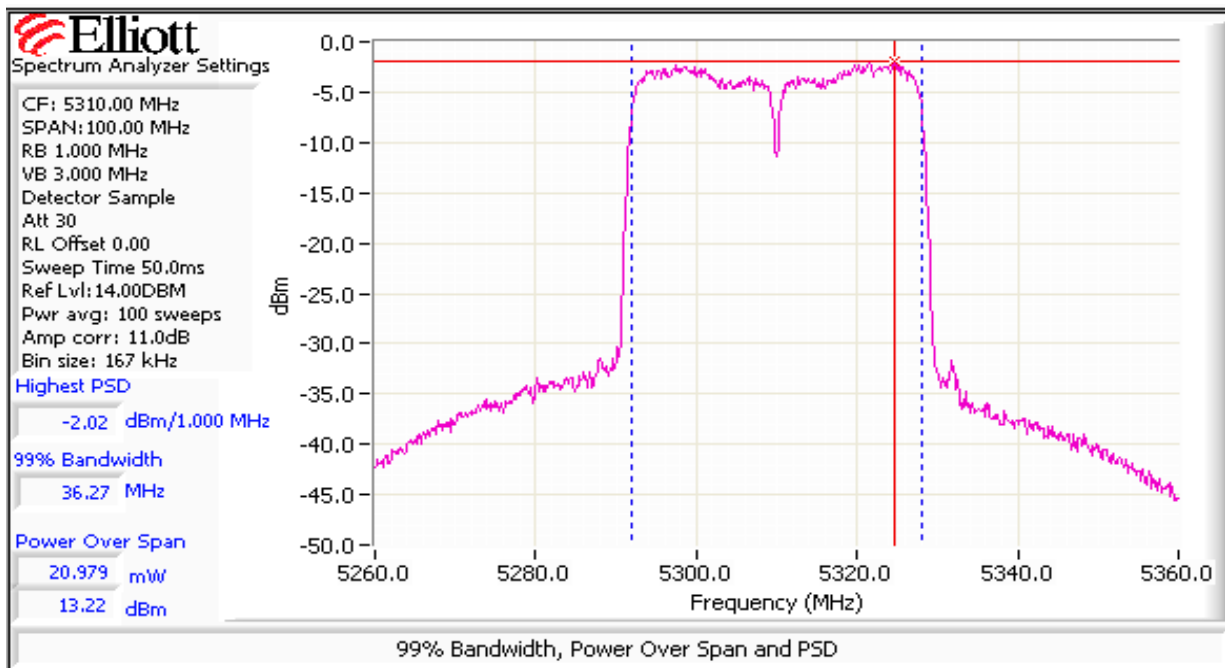
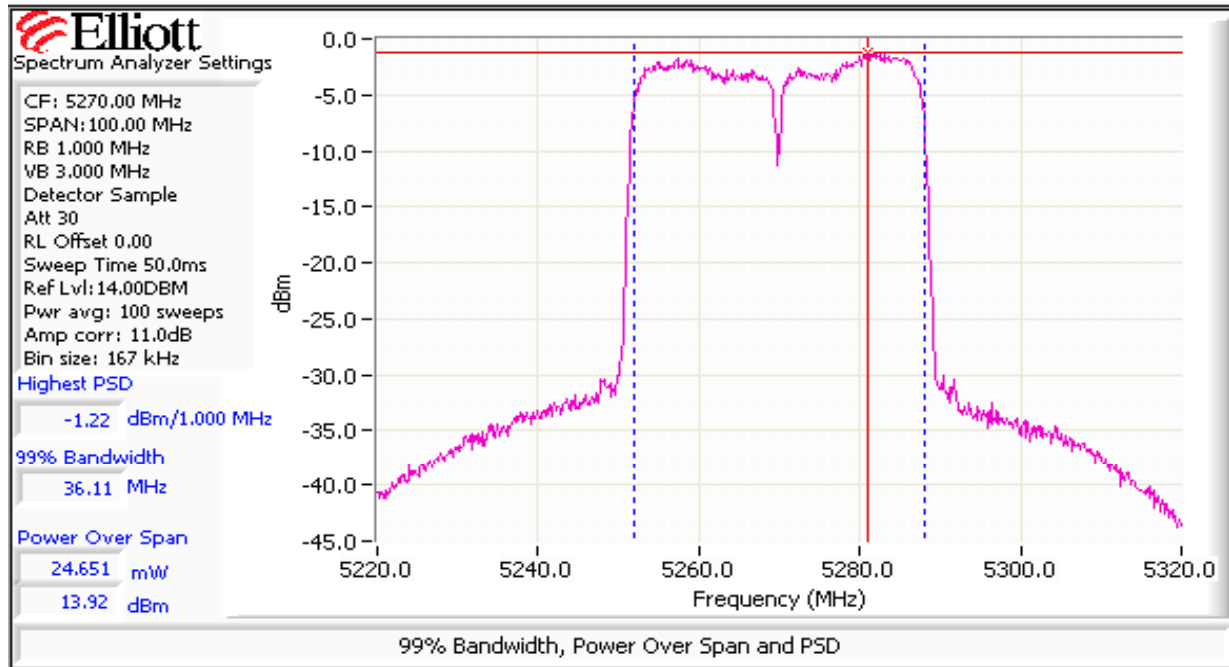

Client: Intel	Job Number: J70979
Model: 512-an MMW	T-Log Number: T71037
Contact: Robert Paxman	Account Manager: Dean Eriksen
Standard: FCC 15 E / RSS -210 (RF Port)	Class: N/A

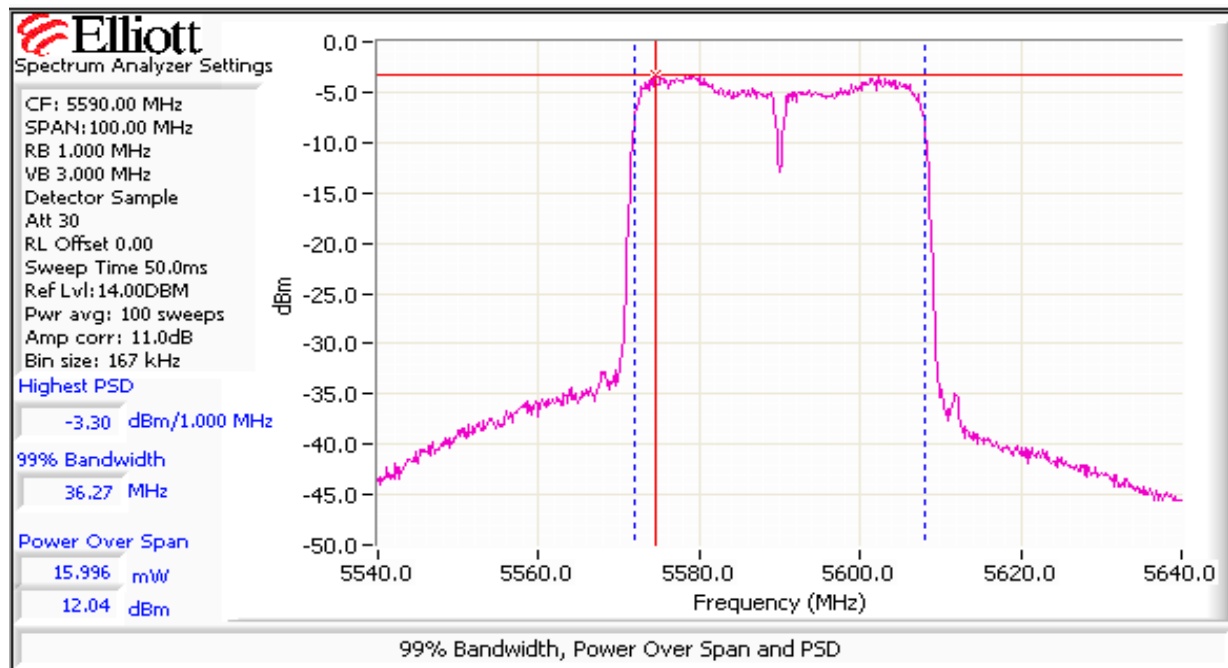
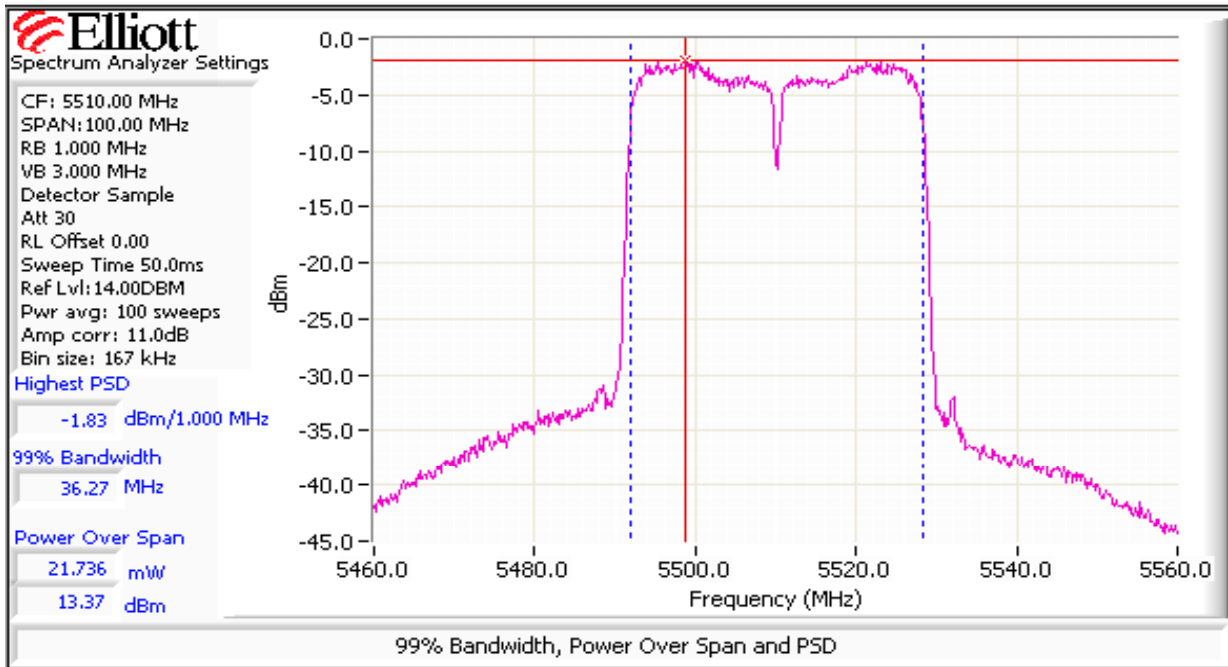

Client: Intel	Job Number: J70979
Model: 512-an MMW	T-Log Number: T71037
Contact: Robert Paxman	Account Manager: Dean Eriksen
Standard: FCC 15 E / RSS -210 (RF Port)	Class: N/A

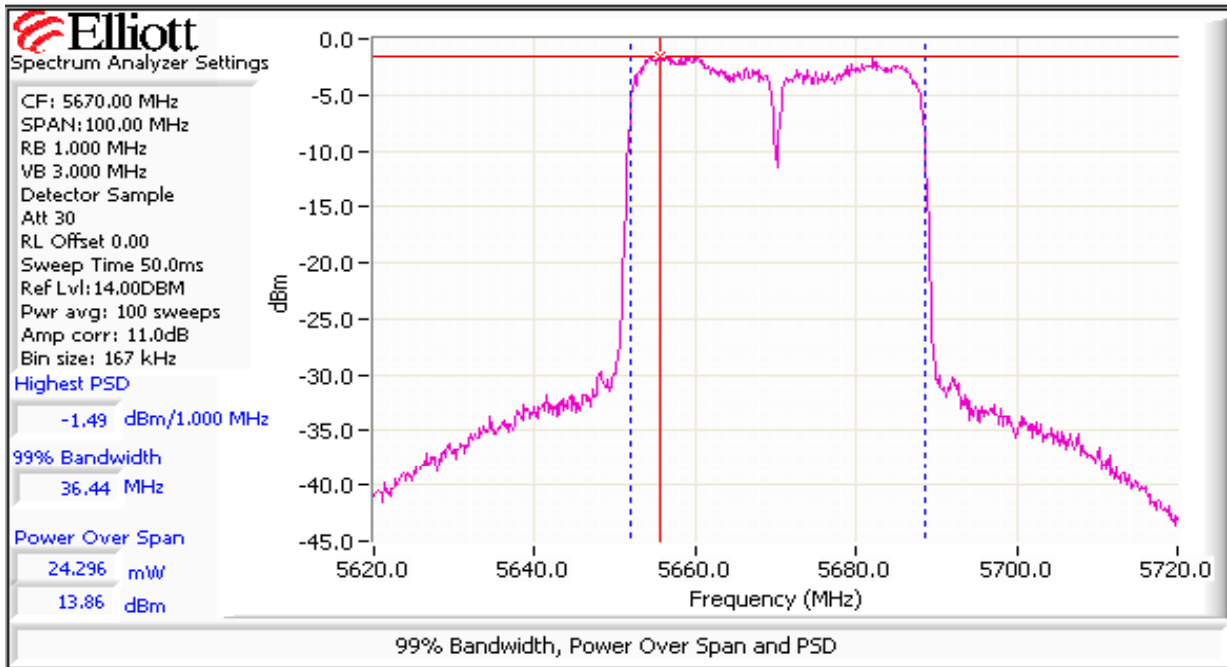
Run #2: Peak Excursion Measurement

Device meets the requirement for the peak excursion

Freq		Peak Excursion(dB)		Freq		Peak Excursion(dB)	
(MHz)	Value	Limit	(MHz)	Value	Limit	(MHz)	Value
5190	11.6	13.0	5510	11.6	13.0		
5230	11.8	13.0	5590	11.7	13.0		
5270	11.5	13.0	5670	12.4	13.0		
5310	11.5	13.0					

Plots Showing Peak Excursion

Trace A: RBW = VBW = 3MHz, Peak hold

Trace B: RBW = 1 MHz, VBW = 3MHz, Integrated average power

Client: Intel	Job Number: J70979
Model: 512-an MMW	T-Log Number: T71037
Contact: Robert Paxman	Account Manager: Dean Eriksen
Standard: FCC 15 E / RSS -210 (RF Port)	Class: N/A

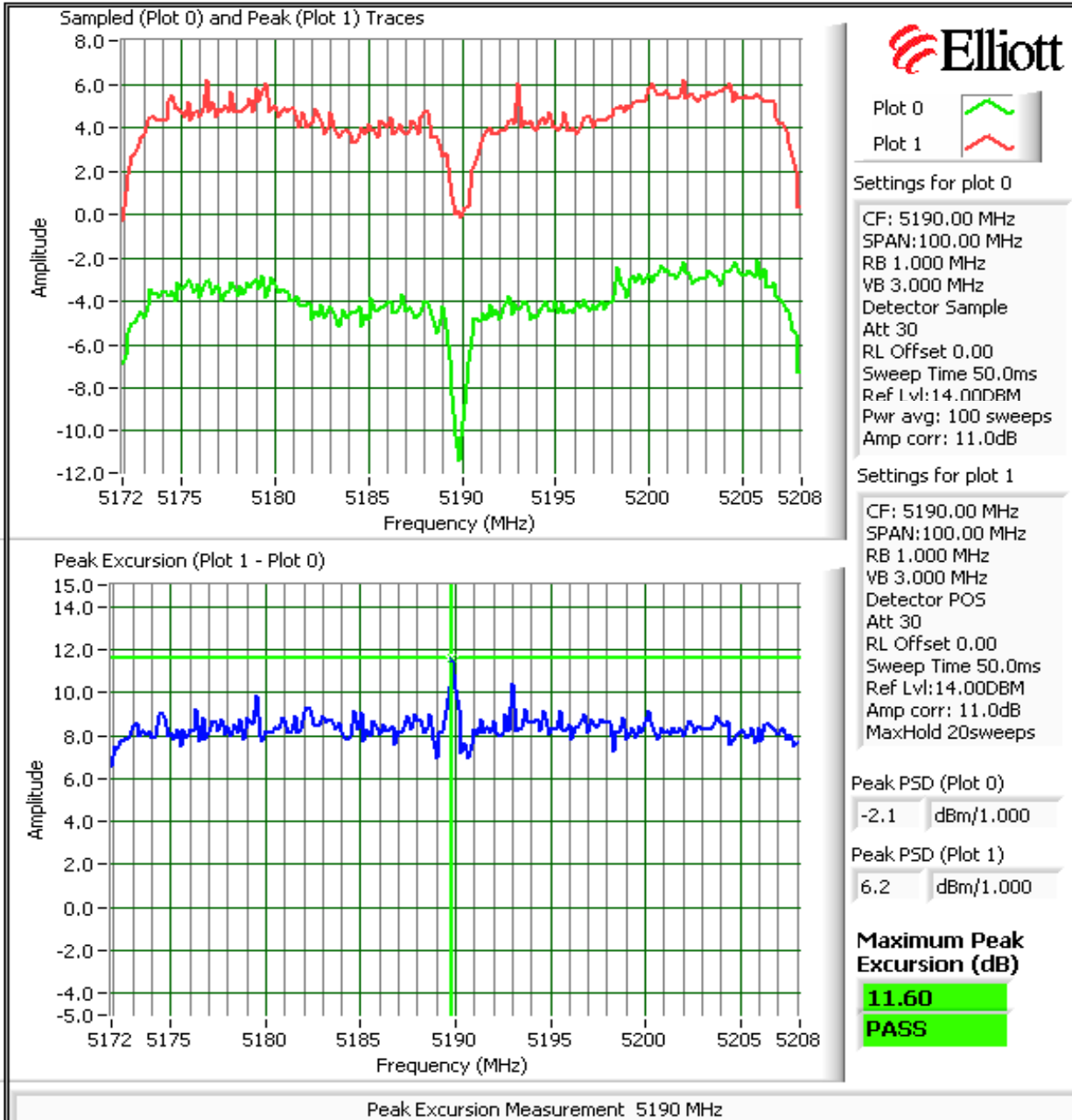

Client: Intel	Job Number: J70979
Model: 512-an MMW	T-Log Number: T71037
Contact: Robert Paxman	Account Manager: Dean Eriksen
Standard: FCC 15 E / RSS -210 (RF Port)	Class: N/A

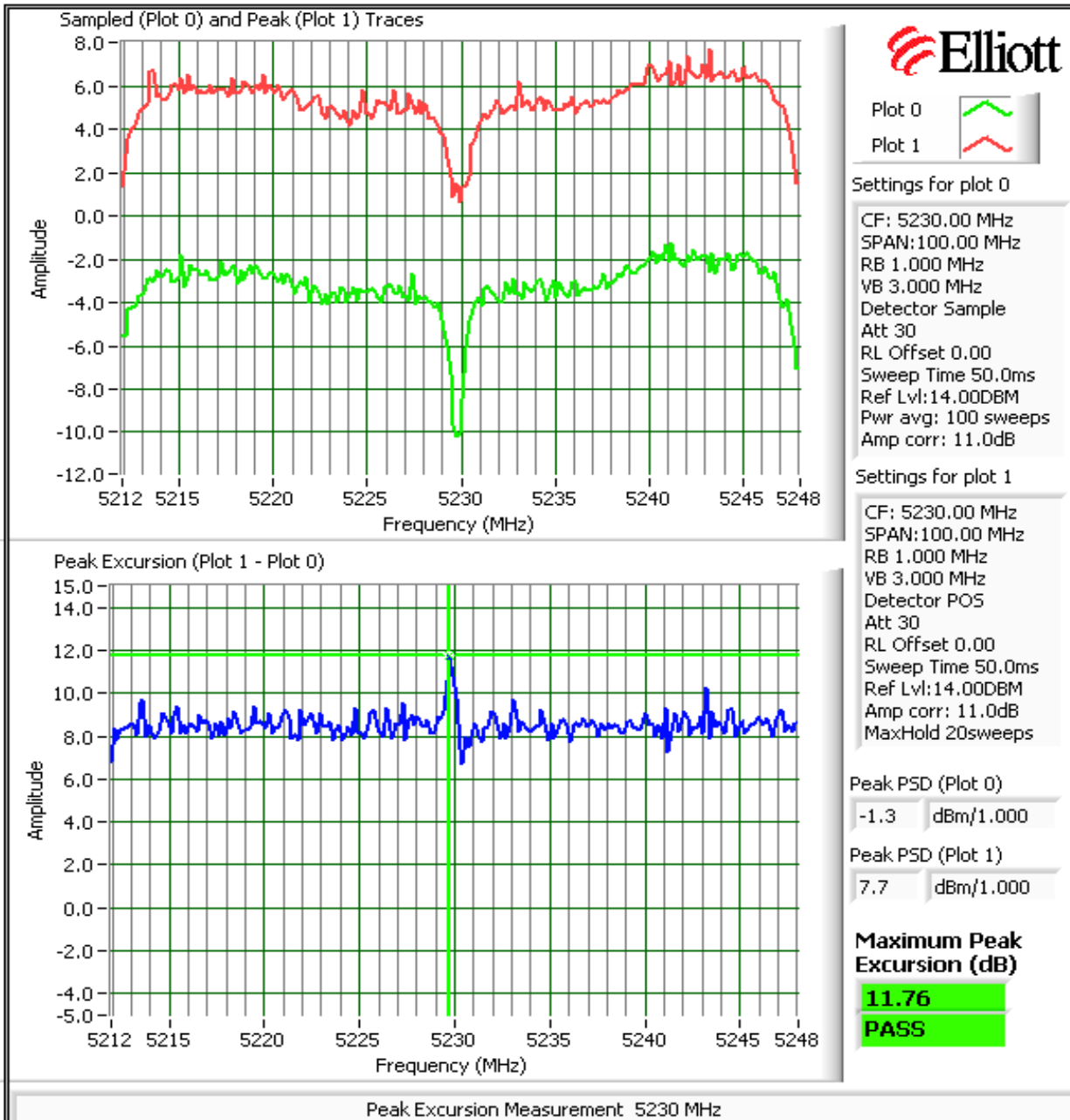

Client: Intel	Job Number: J70979
Model: 512-an MMW	T-Log Number: T71037
Contact: Robert Paxman	Account Manager: Dean Eriksen
Standard: FCC 15 E / RSS -210 (RF Port)	Class: N/A

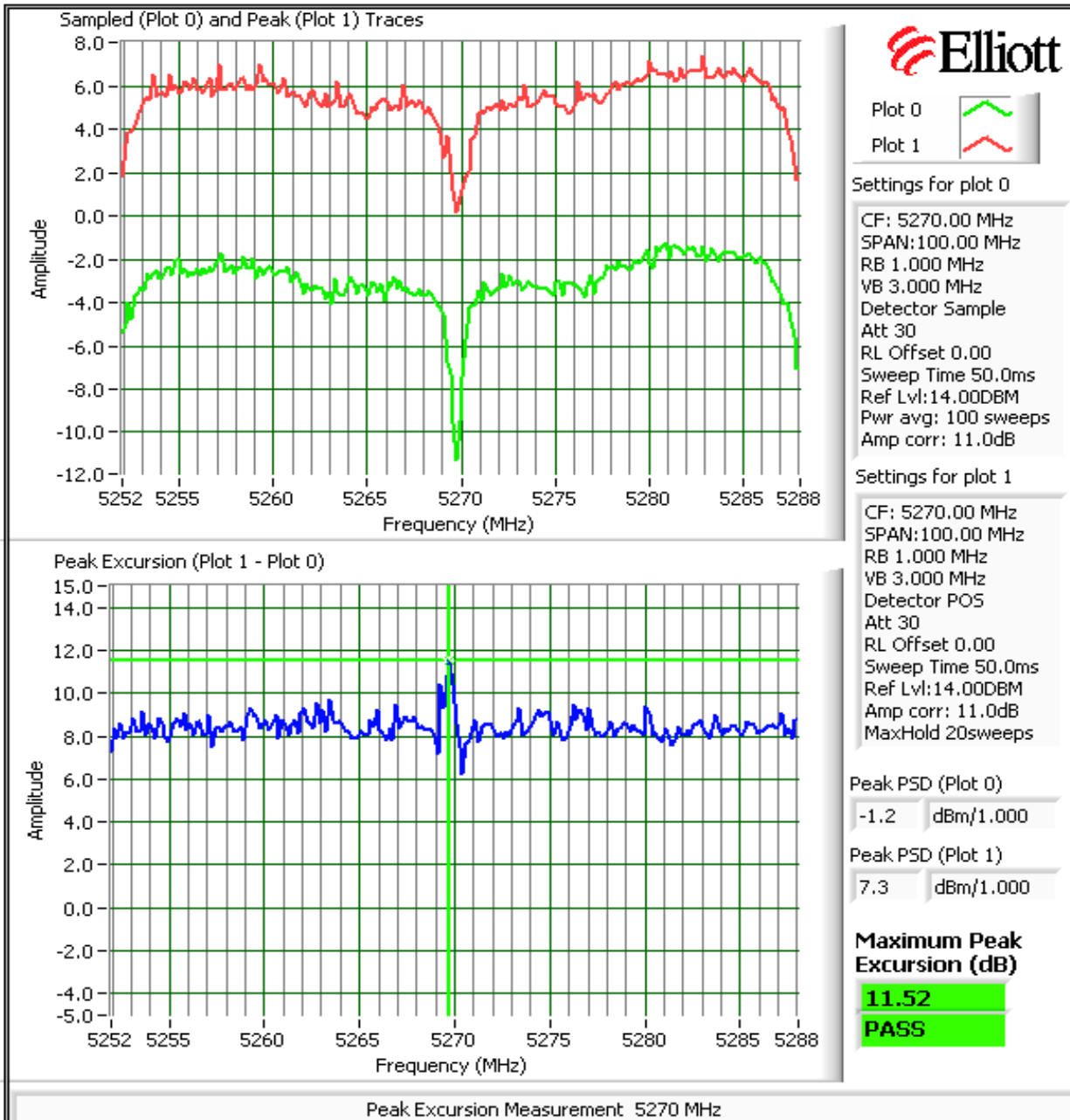

Client: Intel	Job Number: J70979
Model: 512-an MMW	T-Log Number: T71037
Contact: Robert Paxman	Account Manager: Dean Eriksen
Standard: FCC 15 E / RSS -210 (RF Port)	Class: N/A

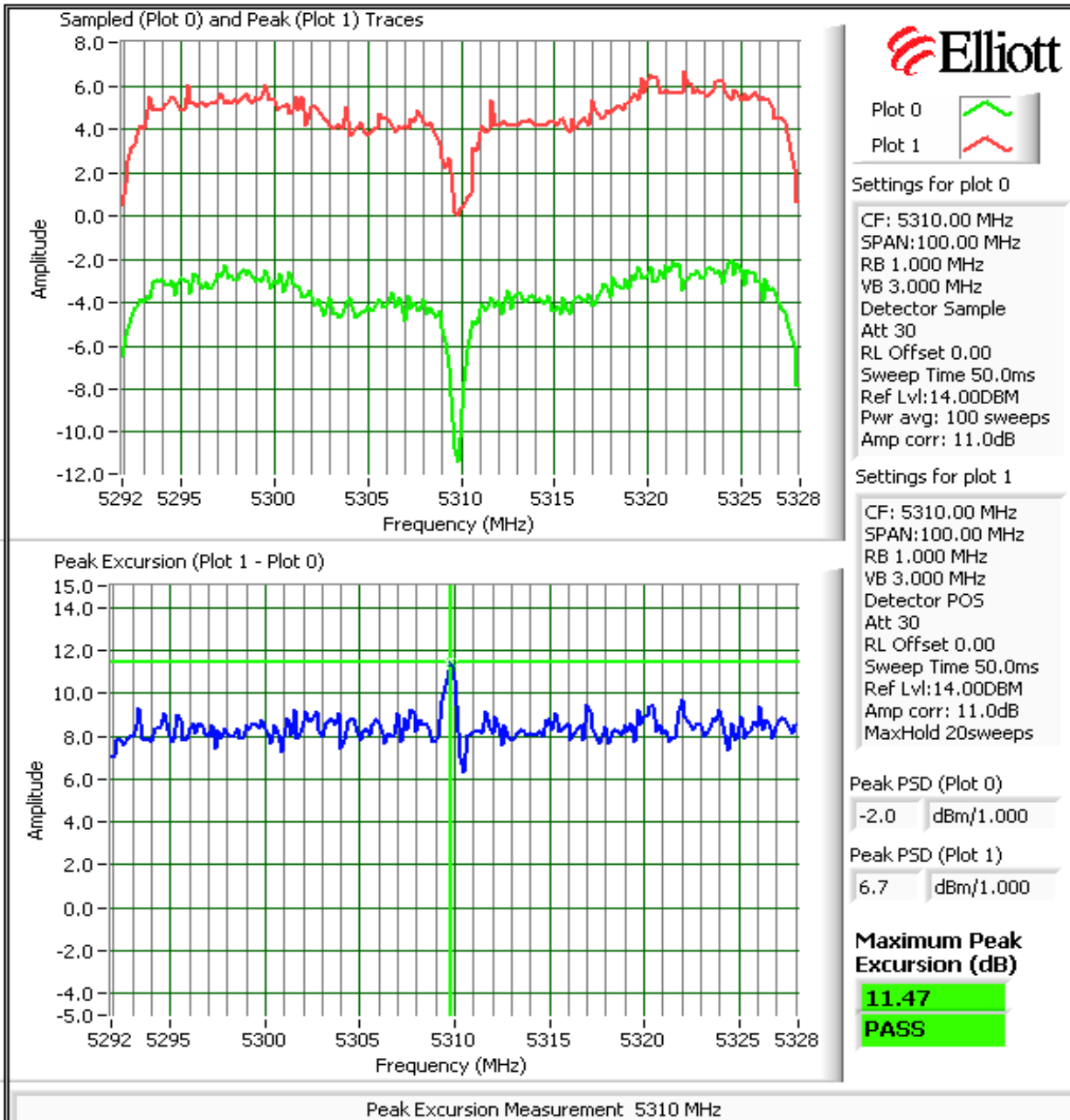

Client: Intel	Job Number: J70979
Model: 512-an MMW	T-Log Number: T71037
Contact: Robert Paxman	Account Manager: Dean Eriksen
Standard: FCC 15 E / RSS -210 (RF Port)	Class: N/A

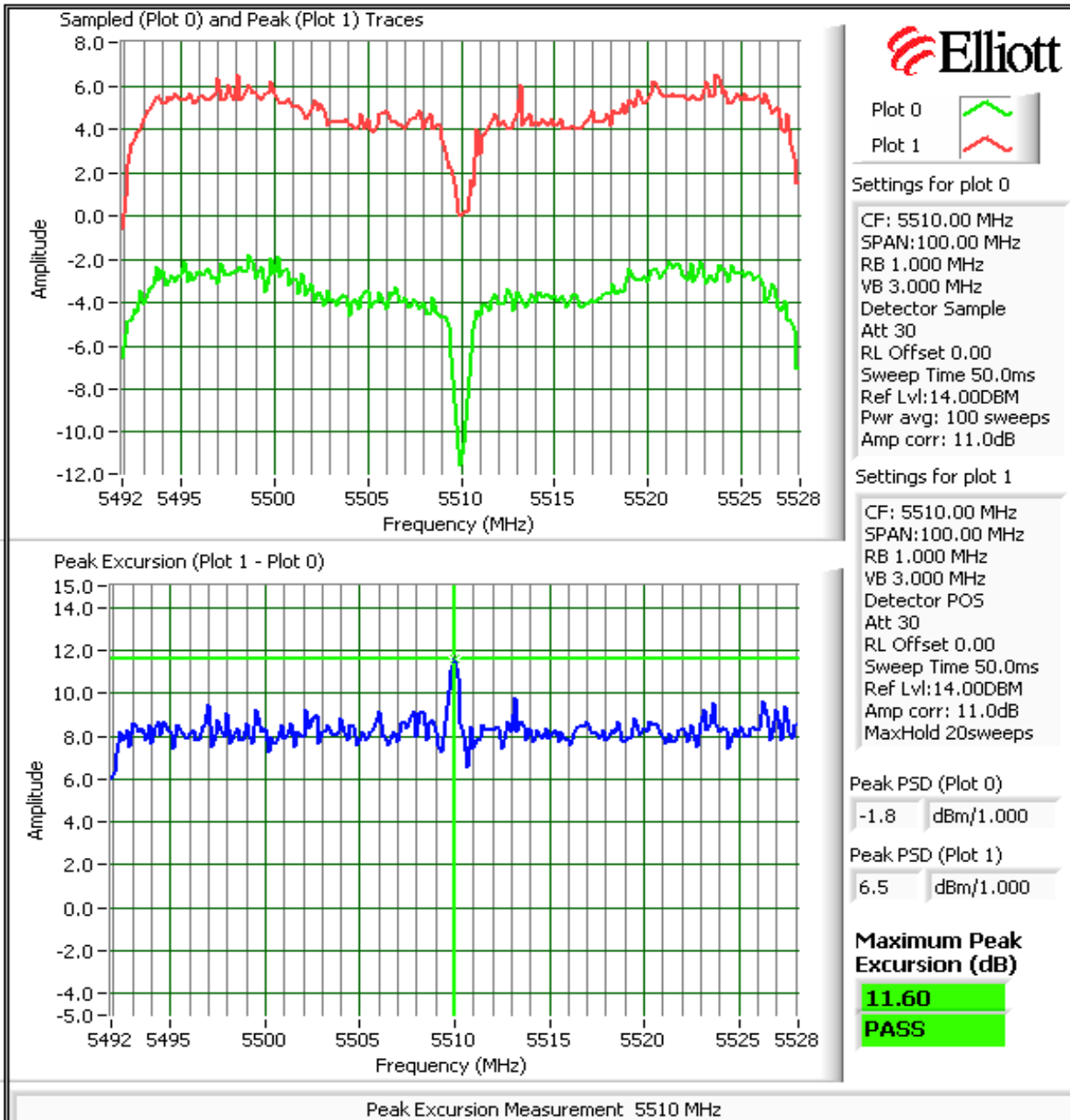

Client: Intel	Job Number: J70979
Model: 512-an MMW	T-Log Number: T71037
Contact: Robert Paxman	Account Manager: Dean Eriksen
Standard: FCC 15 E / RSS -210 (RF Port)	Class: N/A

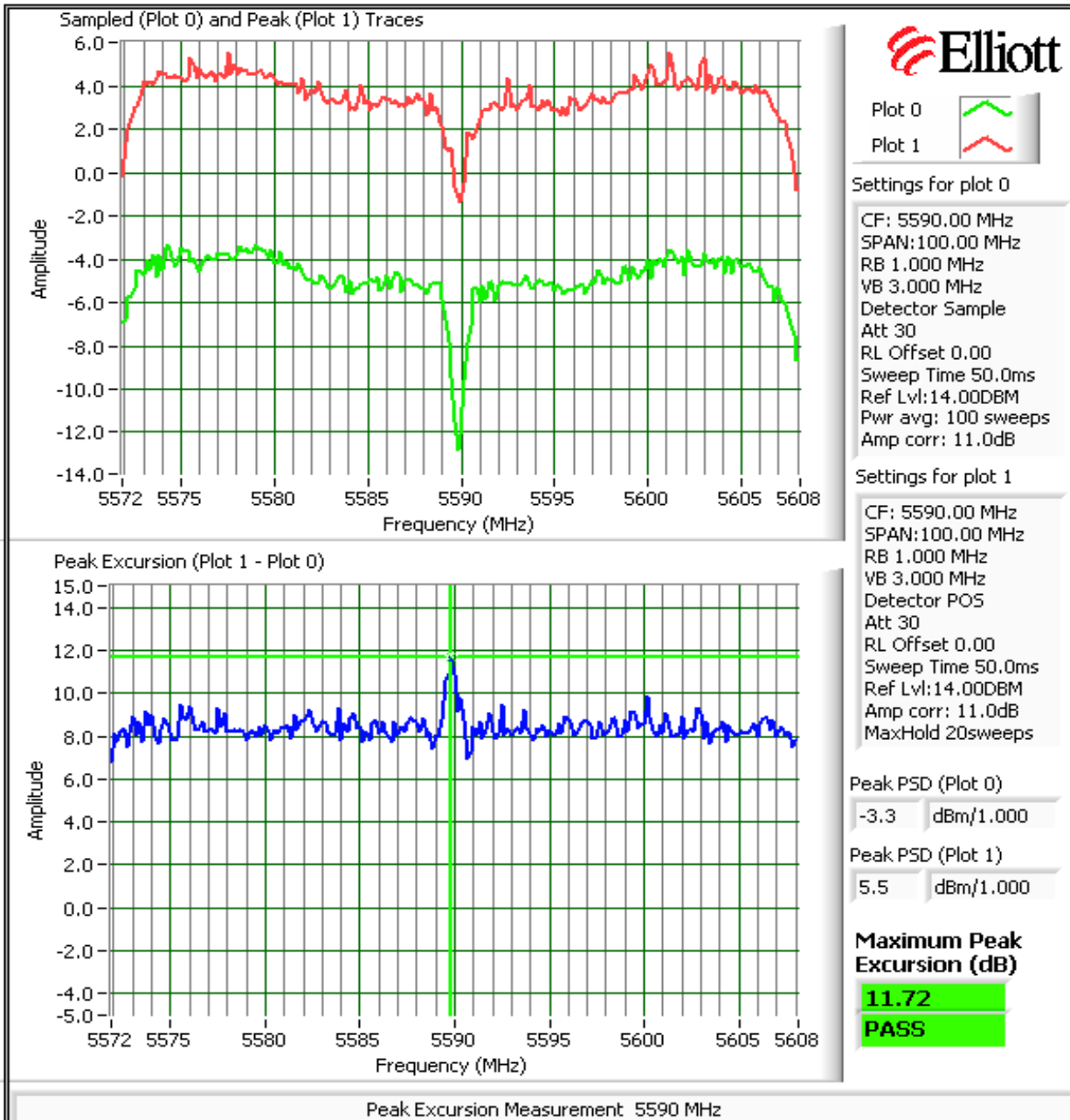

Client: Intel	Job Number: J70979
Model: 512-an MMW	T-Log Number: T71037
Contact: Robert Paxman	Account Manager: Dean Eriksen
Standard: FCC 15 E / RSS -210 (RF Port)	Class: N/A

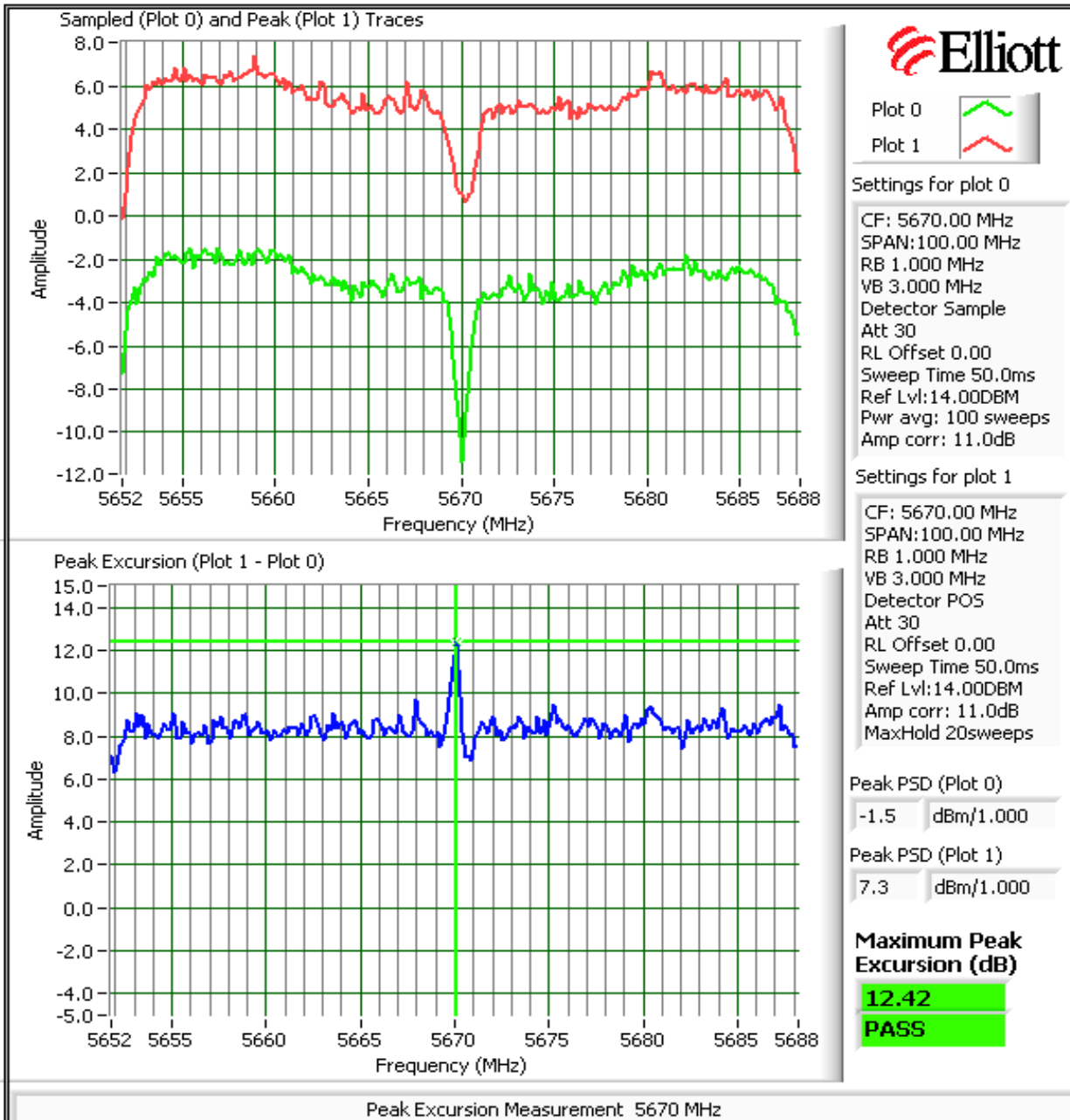

Client:	Intel	Job Number:	J70979
Model:	512-an MMW	T-Log Number:	T71037
		Account Manager:	Dean Eriksen
Contact:	Robert Paxman		
Standard:	FCC 15 E / RSS -210 (RF Port)	Class:	N/A

RSS-210 (LELAN) and FCC 15.407(UNII)
Antenna Port Measurements
Spurious Emissions - 802.11n 40MHz

Test Specific Details

Objective: The objective of this test session is to perform final qualification testing of the EUT with respect to the specification listed above.

Date of Test: 4/14/2008
 Test Engineer: Rafael Varelas
 Test Location: FT Lab #1

Config. Used: 1
 Config Change: None
 EUT Voltage: Powered from host

General Test Configuration

When measuring the conducted emissions from the EUT's antenna port, the antenna port of the EUT was connected to the spectrum analyzer or power meter via a suitable attenuator to prevent overloading the measurement system. All measurements are corrected to allow for the external attenuators and cables used.

Ambient Conditions: Temperature: 19.6 °C
 Rel. Humidity: 33 %

Summary of Results

Run #	Test Performed	Limit	Pass / Fail	Result / Margin
1	Antenna Conducted - Out of Band Spurious, 802.11n-40MHz	15.407(b)	Pass	All emissions below the -27dBm/MHz limit

Modifications Made During Testing

No modifications were made to the EUT during testing

Deviations From The Standard

No deviations were made from the requirements of the standard.

Client: Intel	Job Number: J70979
Model: 512-an MMW	T-Log Number: T71037
Contact: Robert Paxman	Account Manager: Dean Eriksen
Standard: FCC 15 E / RSS -210 (RF Port)	Class: N/A

Run #1: Out Of Band Spurious Emissions - Antenna Conducted, 40MHz 802.11n

The plots were obtained on each of the individual chains separately. The limit of -27dBm has been corrected to account for the antenna gain.

Maximum Antenna Gain:	5.0 dBi	
Spurious Limit:	-27.0 dBm/MHz eirp	
Correction for multiple chains transmitting:	0.0 dBm/MHz eirp	(No MIMO modes)
Limit Used On Plots ^{Note 1} :	-32.0 dBm/MHz	

Note 1: The -27dBm/MHz limit is an eirp limit. The limit for antenna port conducted measurements is adjusted to take into consideration the maximum antenna gain (limit = -27dBm - antenna gain) plus the total number of chains transmitting simultaneously. Radiated field strength measurements for signals more than 50MHz from the bands that are close to the limit are made to determine compliance as the antenna gain is not known at these frequencies.

Note 2: All spurious signals below 1GHz are measured during digital device radiated emissions test.

Note 3: Signals that fall in the restricted bands of 15.205 are subject to the limit of 15.209.

Low Channel, Chain A, 5190 MHz

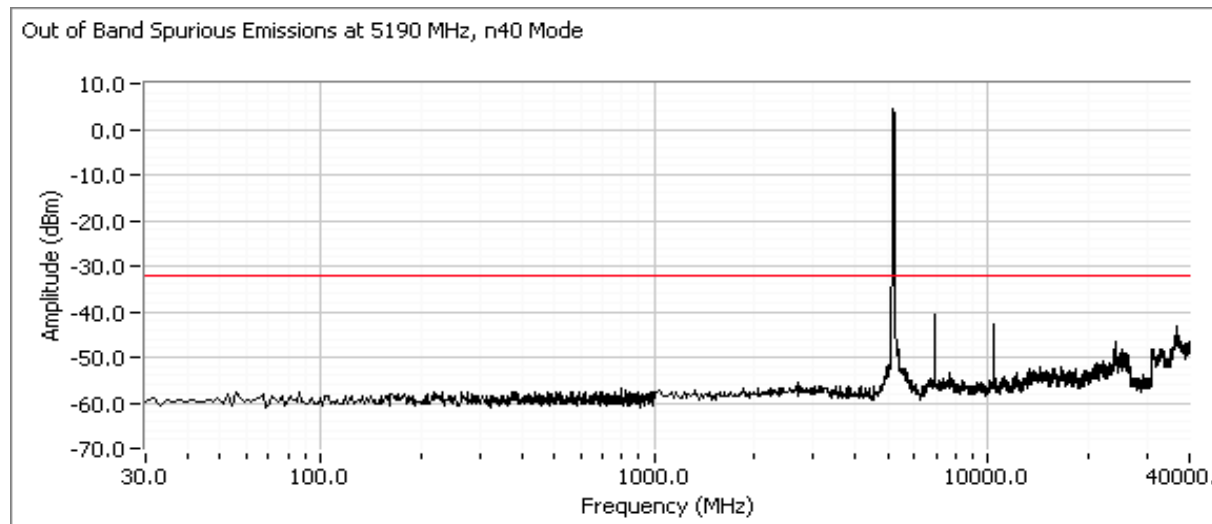

Client: Intel	Job Number: J70979
Model: 512-an MMW	T-Log Number: T71037
Contact: Robert Paxman	Account Manager: Dean Eriksen
Standard: FCC 15 E / RSS -210 (RF Port)	Class: N/A

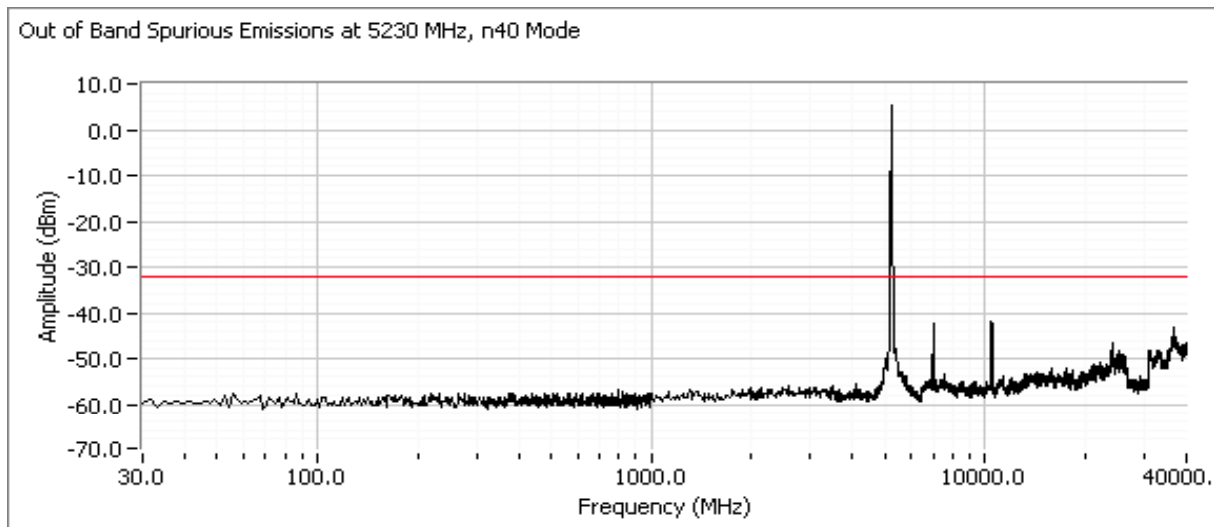
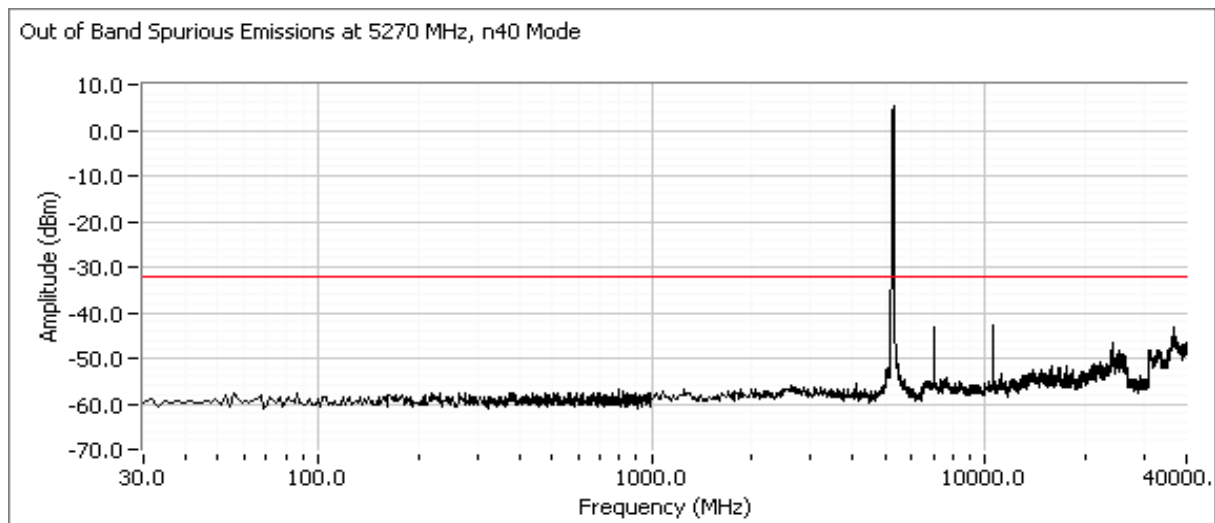
High Channel, Chain A, 5230 MHz

Low Channel, Chain A, 5270 MHz

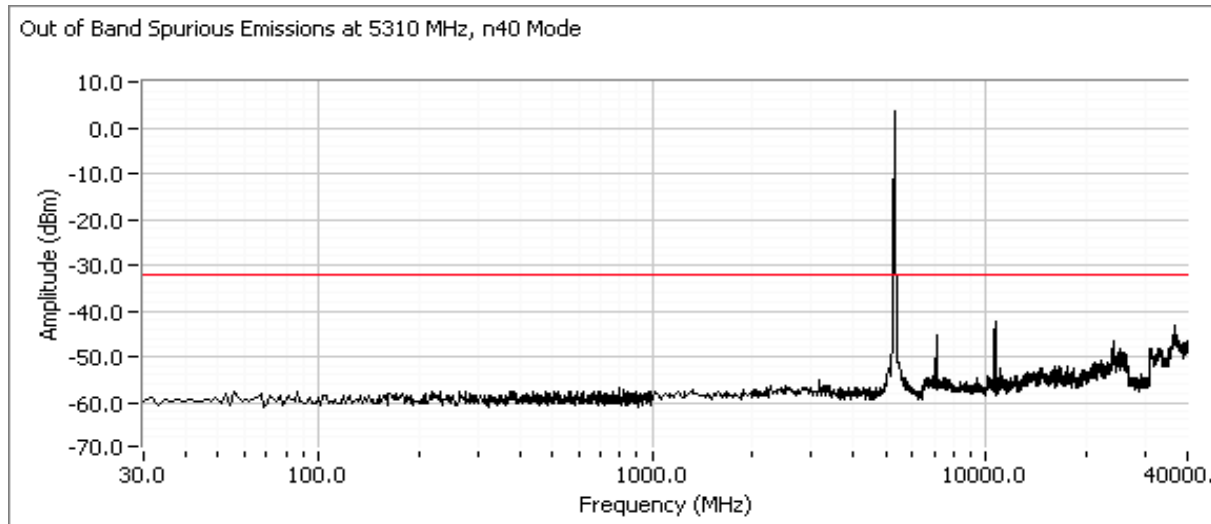
Client: Intel	Job Number: J70979
Model: 512-an MMW	T-Log Number: T71037
Contact: Robert Paxman	Account Manager: Dean Eriksen
Standard: FCC 15 E / RSS -210 (RF Port)	Class: N/A

High Channel, Chain A, 5310 MHz

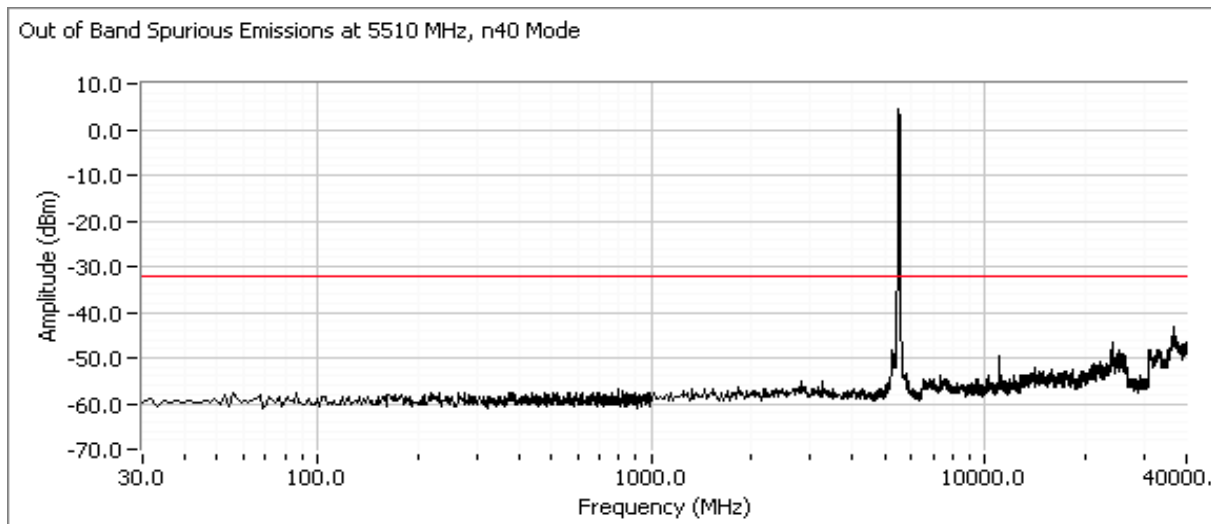
Low Channel, Chain A, 5510 MHz - includes a second plot from 5460 - 5510 MHz, showing compliance with the limit from 5460 - 5470 MHz. Compliance at the 5460 MHz restricted band edge is demonstrated via radiated measurements.



Client: Intel	Job Number: J70979
Model: 512-an MMW	T-Log Number: T71037
Contact: Robert Paxman	Account Manager: Dean Eriksen
Standard: FCC 15 E / RSS -210 (RF Port)	Class: N/A

Out of Band Spurious Emissions at 5510 MHz, n40 Mode, Bandedge

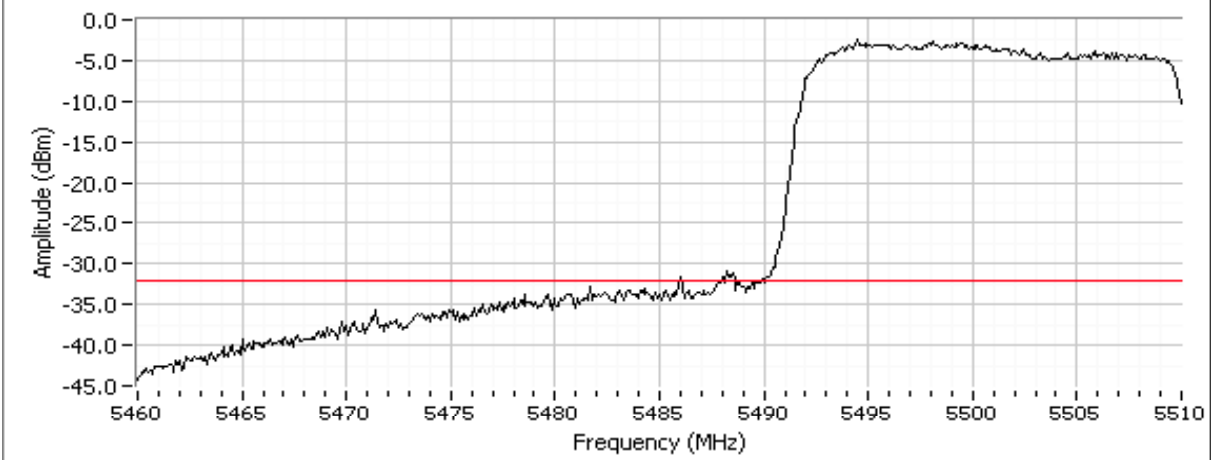

Center Channel, Chain A, 5590 MHz

Out of Band Spurious Emissions at 5590 MHz, n40 Mode

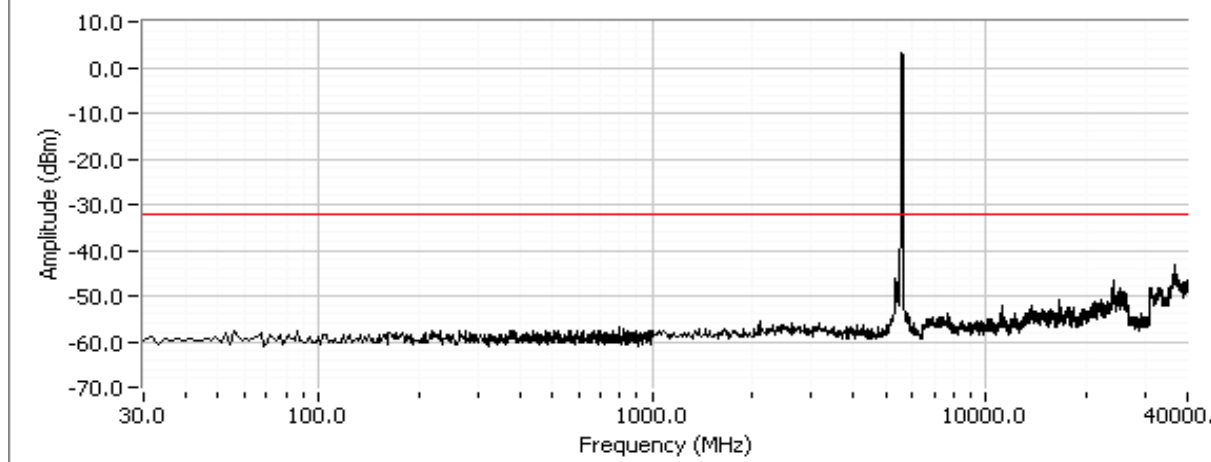

Client: Intel	Job Number: J70979
Model: 512-an MMW	T-Log Number: T71037
Contact: Robert Paxman	Account Manager: Dean Eriksen
Standard: FCC 15 E / RSS -210 (RF Port)	Class: N/A

High Channel, Chain A, 5670 MHz - includes a second plot from 5700 - 5800 MHz, showing compliance with the limit immediately above the 5725 MHz band edge.

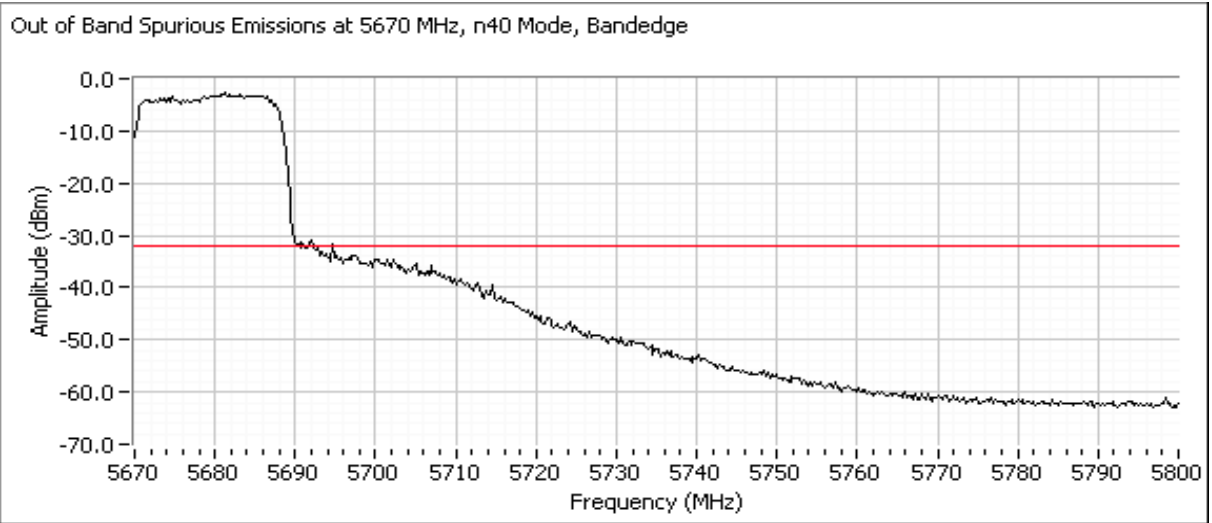
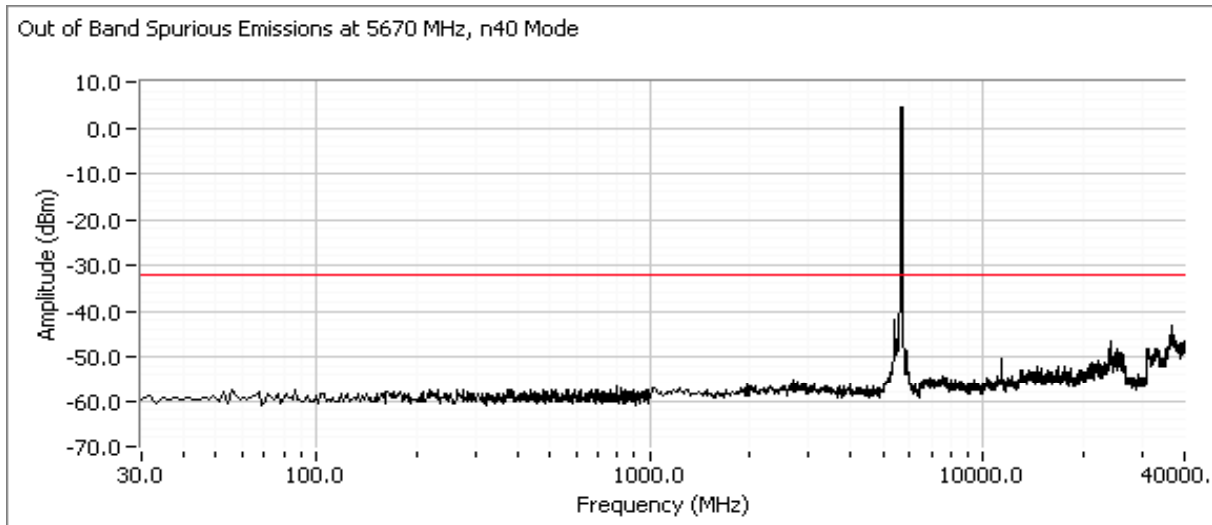



EMC Test Data

Client:	Intel	Job Number:	J70979
Model:	512an MMW	T-Log Number:	T71043
		Account Manager:	Briggs / Eriksen
Contact:	Robert Paxman		-
Emissions Standard(s):	RSS 210 / FCC 15.407 UNII (Radiated)	Class:	
Immunity Standard(s):	-	Environment:	-

EMC Test Data

For The

Intel

Model

512an MMW

Date of Last Test: 4/16/2008

Client: Intel	Job Number: J70979
Model: 512an MMW	T-Log Number: T71043
	Account Manager: Briggs / Eriksen
Contact: Robert Paxman	
Standard: RSS 210 / FCC 15.407 UNII (Radiated)	Class: Enter on cover sheet

Radiated Emissions

Test Specific Details

Objective: The objective of this test session is to perform final qualification testing of the EUT with respect to the specification listed above.

Date of Test: 4/16/2008
Test Engineer: Ben Jing
Test Location: FT Chamber # 3

Config. Used: 1
Config Change: None
Host Unit Voltage 120V/60Hz

General Test Configuration

The EUT and all local support equipment were located on the turntable for radiated emissions testing. Remote support equipment was located approximately 30 meters from the test area with all I/O connections running on top of the groundplane.

The test distance and extrapolation factor (if applicable) are detailed under each run description.

Note, **preliminary** testing indicates that the emissions were maximized by orientation of the EUT and elevation of the measurement antenna. **Maximized** testing indicated that the emissions were maximized by orientation of the EUT, elevation of the measurement antenna, and manipulation of the EUT's interface cables.

Ambient Conditions: Temperature: 20 °C
Rel. Humidity: 37 %

Summary of Results

Run #	Test Performed	Limit	Result	Margin
1,2	RE, 30 - 1000MHz, Maximized Emissions	RSS GEN / FCC 15.107	Pass	43.4dBµV/m @ 108.29MHz (-0.1dB)
3 - Single Receiver chain	RE, 1000 - 18000 MHz, Maximized Emissions	RSS GEN	Pass	50.9dBµV/m @ 3000.4MHz (-3.1dB)
4 - All Receiver chains	RE, 1000 - 18000 MHz, Maximized Emissions	RSS GEN	Pass	51.4dBµV/m @ 3000.3MHz (-2.6dB)

Modifications Made During Testing

No modifications were made to the EUT during testing

Deviations From The Standard

No deviations were made from the requirements of the standard.

Client: Intel	Job Number: J70979
Model: 512an MMW	T-Log Number: T71043
Contact: Robert Paxman	Account Manager: Briggs / Eriksen
Standard: RSS 210 / FCC 15.407 UNII (Radiated)	Class: Enter on cover sheet

Run #1: Preliminary Radiated Emissions, 30-1000 MHz

Note - preliminary scans were made with the device tuned to the center channel in each operating band in both transmit and receive modes. There were no significant differences in the emissions profiles for all modes/bands tested in the frequency range 30 - 1000 MHz. Final measurements were taken with the device operating in receive mode and tuned to 2437 MHz. The results are representative of all operating modes.

Frequency Range	Test Distance	Limit Distance	Extrapolation Factor
30 - 1000 MHz	3	3	0.0

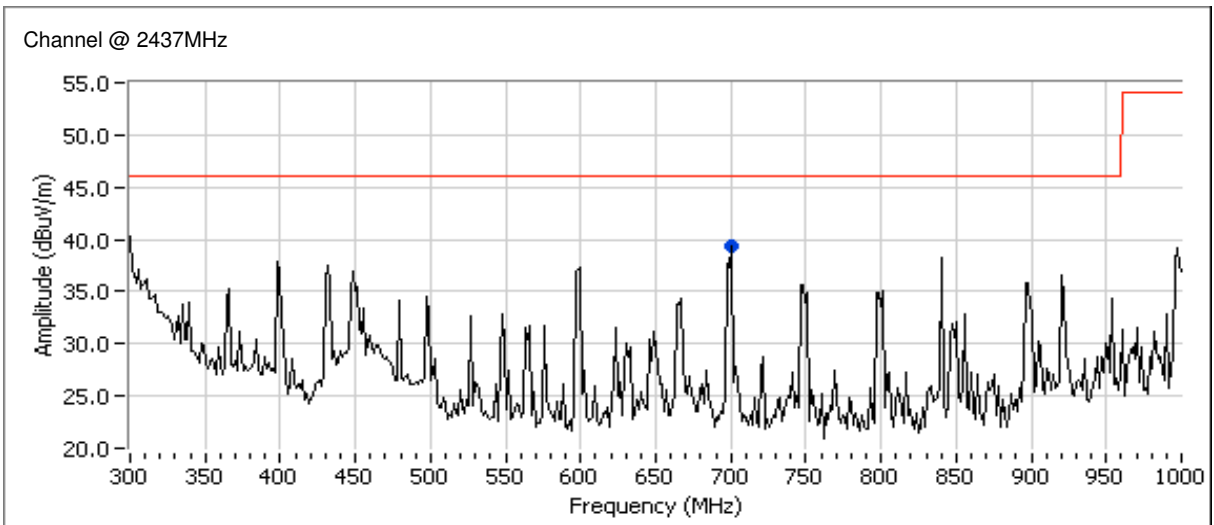
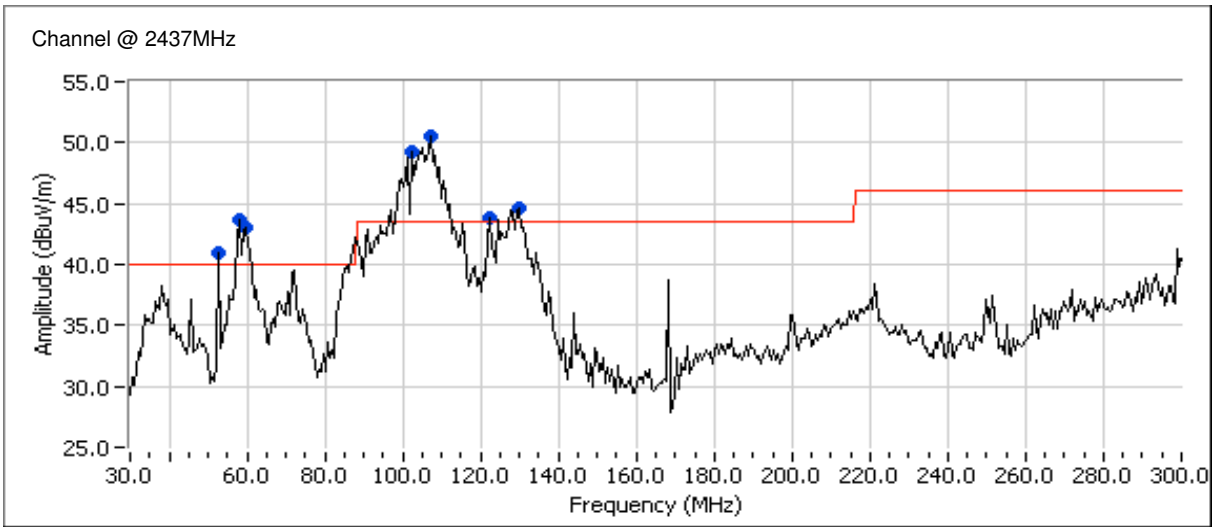



EMC Test Data

Client: Intel	Job Number: J70979
Model: 512an MMW	T-Log Number: T71043
	Account Manager: Briggs / Eriksen
Contact: Robert Paxman	
Standard: RSS 210 / FCC 15.407 UNII (Radiated)	Class: Enter on cover sheet

Run #1a Receiver tuned to 2437 MHz, all chains active - preliminary scan

Frequency	Level	Pol	FCC 15.209/RSS 210		Detector	Azimuth	Height	Comments
MHz	dBμV/m	v/h	Limit	Margin	Pk/QP/Avg	degrees	meters	
108.287	43.4	H	43.5	-0.1	QP	24	2.5	
101.489	39.9	H	43.5	-3.6	QP	38	3.0	
58.620	36.4	V	40.0	-3.6	QP	129	2.5	
58.789	34.1	V	40.0	-5.9	QP	274	1.0	
128.792	37.0	H	43.5	-6.5	QP	166	2.5	
123.411	35.4	H	43.5	-8.1	QP	129	2.5	
698.557	33.3	H	46.0	-12.7	QP	116	1.5	
53.878	21.9	V	40.0	-18.1	QP	292	2.0	

Run #2: Maximized Readings From Run #1

Frequency Range	Test Distance	Limit Distance	Extrapolation Factor
30 - 1000 MHz	3	3	0.0

Frequency	Level	Pol	FCC 15.209/RSS 210		Detector	Azimuth	Height	Comments
MHz	dBμV/m	v/h	Limit	Margin	Pk/QP/Avg	degrees	meters	
58.620	36.4	V	40.0	-3.6	QP	129	2.5	
58.789	34.1	V	40.0	-5.9	QP	274	1.0	
101.489	39.9	H	43.5	-3.6	QP	38	3.0	
108.287	43.4	H	43.5	-0.1	QP	24	2.5	
123.411	35.4	H	43.5	-8.1	QP	129	2.5	
128.792	37.0	H	43.5	-6.5	QP	166	2.5	

Client: Intel	Job Number: J70979
Model: 512an MMW	T-Log Number: T71043
Contact: Robert Paxman	Account Manager: Briggs / Eriksen
Standard: RSS 210 / FCC 15.407 UNII (Radiated)	Class: Enter on cover sheet

Run #3: Maximized readings, 1000 - 18000 MHz, Single Receiver Active

Frequency Range	Test Distance	Limit Distance	Extrapolation Factor
1000 - 10000 MHz	3	3	0.0
10000 - 18000 MHz	1	3	-9.5

Receiver Tuned to 5200 MHz - Single chain active

Frequency MHz	Level dB μ V/m	Pol v/h	RSS GEN		Detector Pk/QP/Avg	Azimuth degrees	Height meters	Comments
			Limit	Margin				
3000.350	46.6	V	54.0	-7.4	AVG	185	1.0	
6000.700	46.6	V	54.0	-7.4	AVG	268	1.9	
6901.120	35.0	V	54.0	-19.0	AVG	217	1.6	
3000.350	51.4	V	74.0	-22.6	PK	185	1.0	
6000.700	51.6	V	74.0	-22.4	PK	268	1.9	
6901.120	46.9	V	74.0	-27.1	PK	217	1.6	

Note 1: Above 1 GHz, the limit is for an average measurement. In addition, the peak value of any emission above 1 GHz, can not exceed the average limit by more than 20 dB.

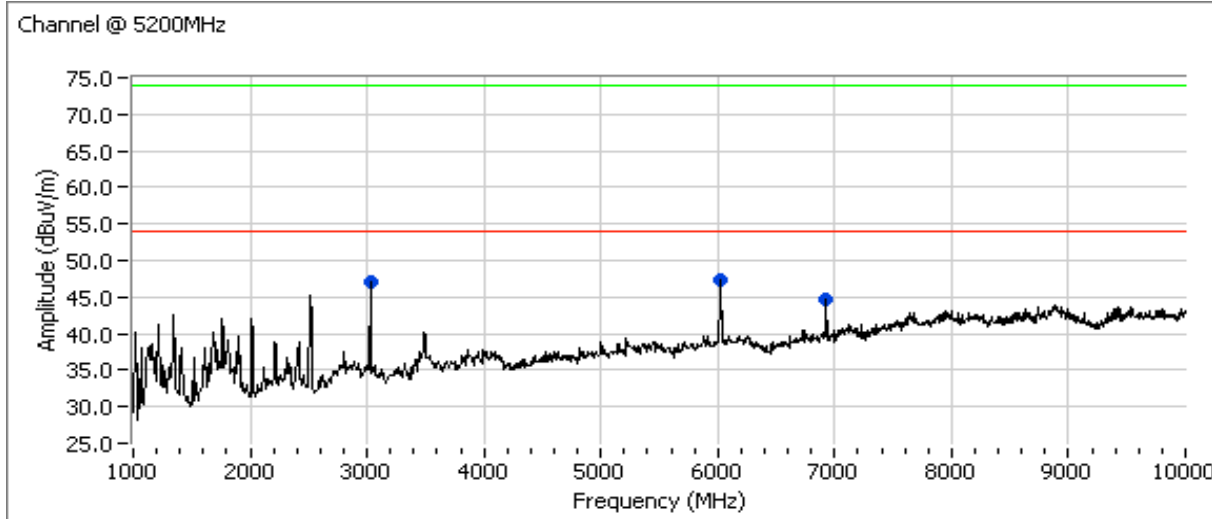

Client: Intel	Job Number: J70979
Model: 512an MMW	T-Log Number: T71043
Contact: Robert Paxman	Account Manager: Briggs / Eriksen
Standard: RSS 210 / FCC 15.407 UNII (Radiated)	Class: Enter on cover sheet

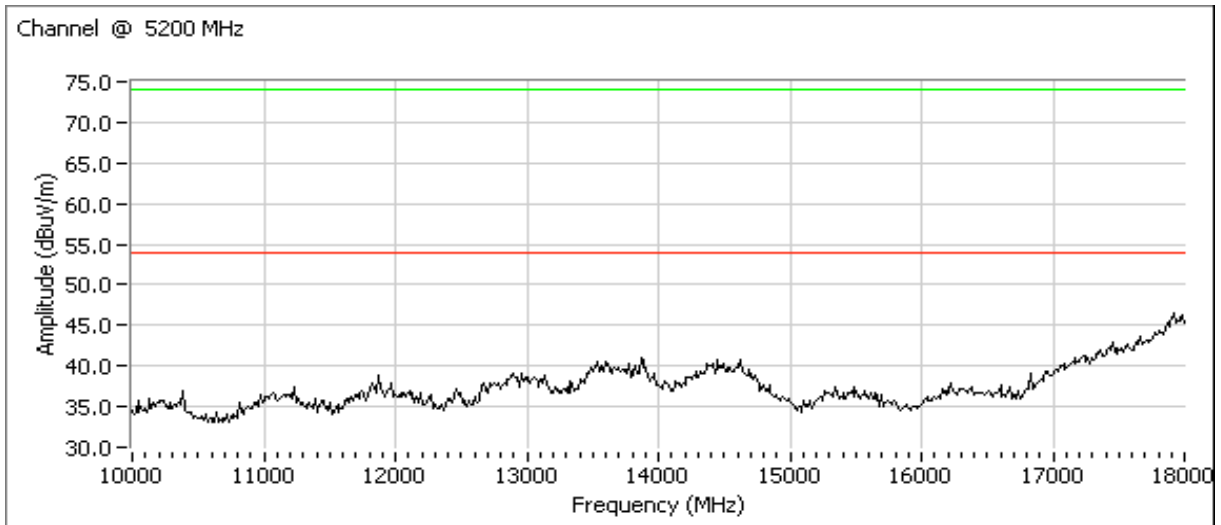

Client: Intel	Job Number: J70979
Model: 512an MMW	T-Log Number: T71043
Contact: Robert Paxman	Account Manager: Briggs / Eriksen
Standard: RSS 210 / FCC 15.407 UNII (Radiated)	Class: Enter on cover sheet

Receiver Tuned to 5280 MHz - Single chain active

Frequency MHz	Level dB μ V/m	Pol v/h	RSS GEN		Detector Pk/QP/Avg	Azimuth degrees	Height meters	Comments
			Limit	Margin				
1046.990	31.8	H	54.0	-22.2	AVG	306	1.0	
3000.350	50.6	V	54.0	-3.4	AVG	266	1.0	
6000.770	48.6	V	54.0	-5.4	AVG	268	1.5	
1046.990	51.4	H	74.0	-22.6	PK	306	1.0	
3000.350	54.2	V	74.0	-19.8	PK	266	1.0	
6000.770	52.4	V	74.0	-21.6	PK	268	1.5	

Note 1: Above 1 GHz, the limit is for an average measurement. In addition, the peak value of any emission above 1 GHz, can not exceed the average limit by more than 20 dB.

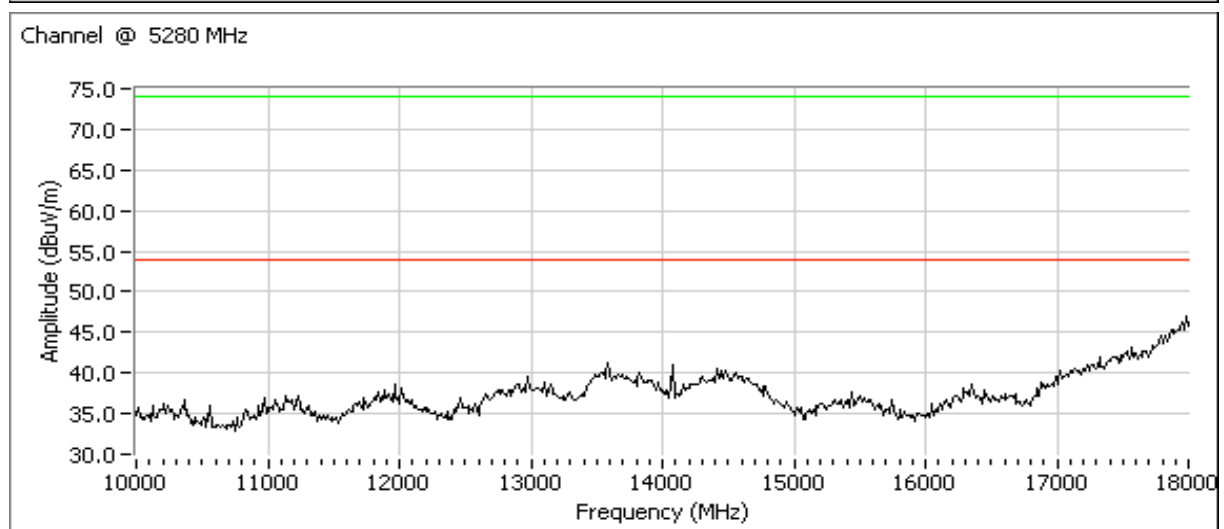
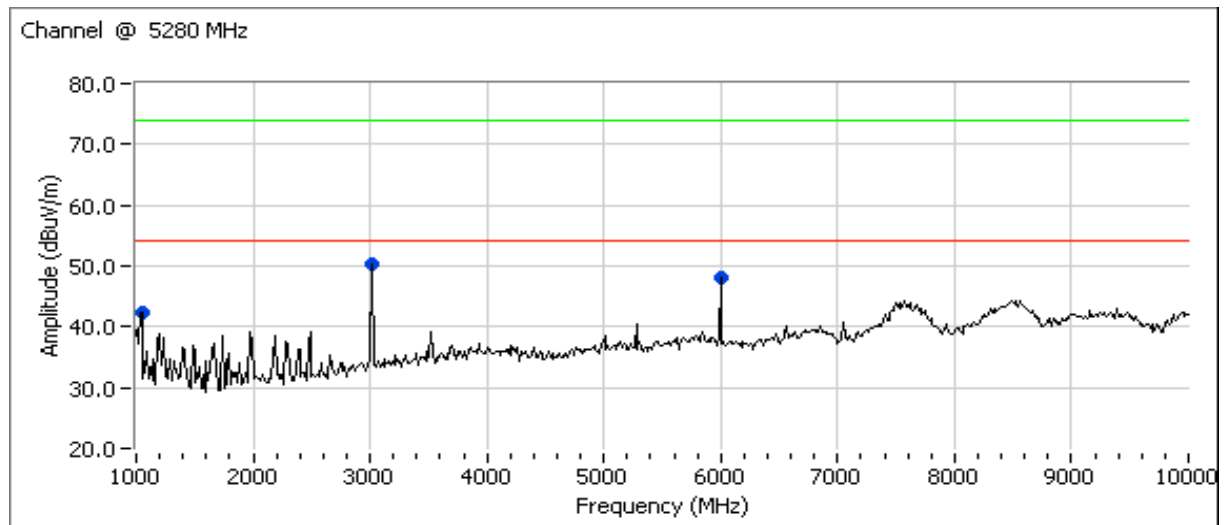

Client: Intel	Job Number: J70979
Model: 512an MMW	T-Log Number: T71043
Contact: Robert Paxman	Account Manager: Briggs / Eriksen
Standard: RSS 210 / FCC 15.407 UNII (Radiated)	Class: Enter on cover sheet

Receiver Tuned to 5600 MHz - Single chain active

Frequency MHz	Level dB μ V/m	Pol v/h	RSS GEN		Detector Pk/QP/Avg	Azimuth degrees	Height meters	Comments
			Limit	Margin				
1046.310	32.9	H	54.0	-21.1	AVG	309	1.0	
3000.370	50.9	V	54.0	-3.1	AVG	265	1.0	
6000.690	49.1	V	54.0	-4.9	AVG	260	1.5	
7466.660	48.8	V	54.0	-5.2	AVG	152	1.5	
1046.310	51.2	H	74.0	-22.8	PK	309	1.0	
3000.370	54.2	V	74.0	-19.8	PK	265	1.0	
6000.690	52.9	V	74.0	-21.1	PK	260	1.5	
7466.660	55.0	V	74.0	-19.0	PK	152	1.5	

Note 1: Above 1 GHz, the limit is for an average measurement. In addition, the peak value of any emission above 1 GHz, can not exceed the average limit by more than 20 dB.

Channel @ 5600 MHz

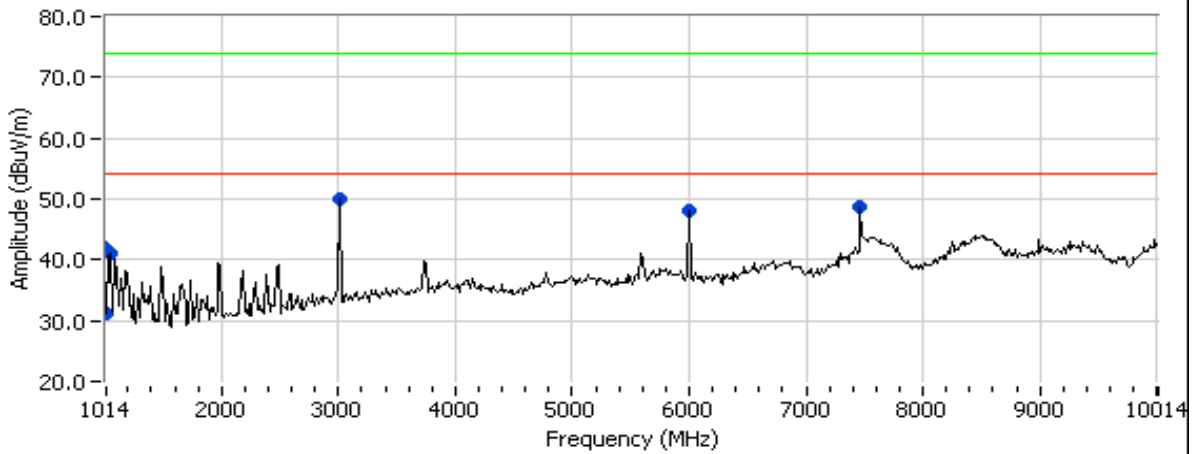

Channel @ 5600 MHz

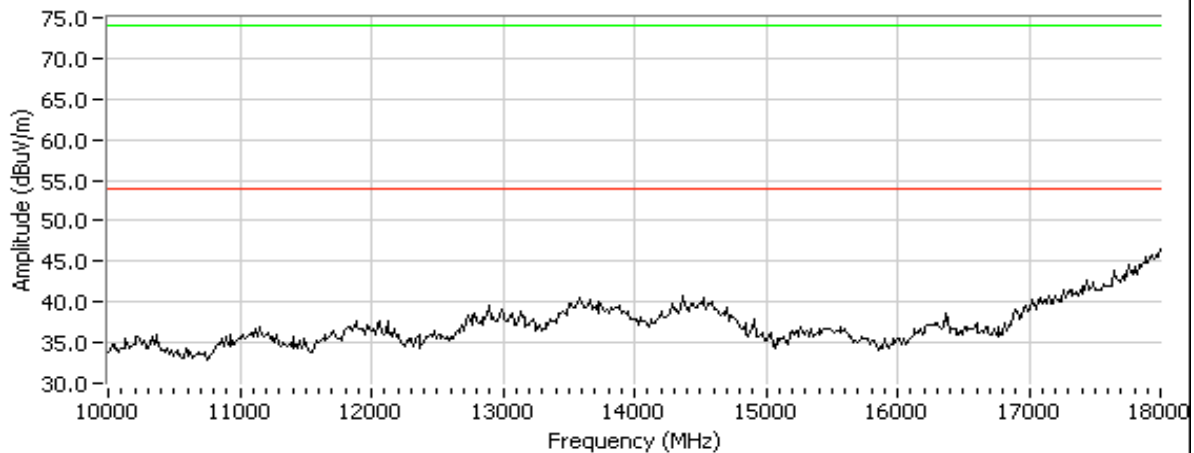

Client: Intel	Job Number: J70979
Model: 512an MMW	T-Log Number: T71043
Contact: Robert Paxman	Account Manager: Briggs / Eriksen
Standard: RSS 210 / FCC 15.407 UNII (Radiated)	Class: Enter on cover sheet

Run #4: Maximized readings, 1000 - 18000 MHz, All Receivers Active

Receiver Tuned to 5200 MHz - All chains active

Frequency MHz	Level dB μ V/m	Pol v/h	RSS GEN		Detector Pk/QP/Avg	Azimuth degrees	Height meters	Comments
			Limit	Margin				
3000.340	51.4	V	54.0	-2.6	AVG	266	1.0	
5200.030	42.8	V	54.0	-11.2	AVG	157	1.0	
6000.750	49.0	V	54.0	-5.0	AVG	263	1.5	
6933.280	44.3	V	54.0	-9.7	AVG	141	1.5	
10399.890	39.4	V	54.0	-14.6	AVG	235	1.0	
3000.340	54.6	V	74.0	-19.4	PK	266	1.0	
5200.030	48.1	V	74.0	-25.9	PK	157	1.0	
6000.750	52.8	V	74.0	-21.2	PK	263	1.5	
6933.280	49.8	V	74.0	-24.2	PK	141	1.5	
10399.890	44.6	V	74.0	-29.4	PK	235	1.0	

Note 1: Above 1 GHz, the limit is for an average measurement. In addition, the peak value of any emission above 1 GHz, can not exceed the average limit by more than 20 dB.

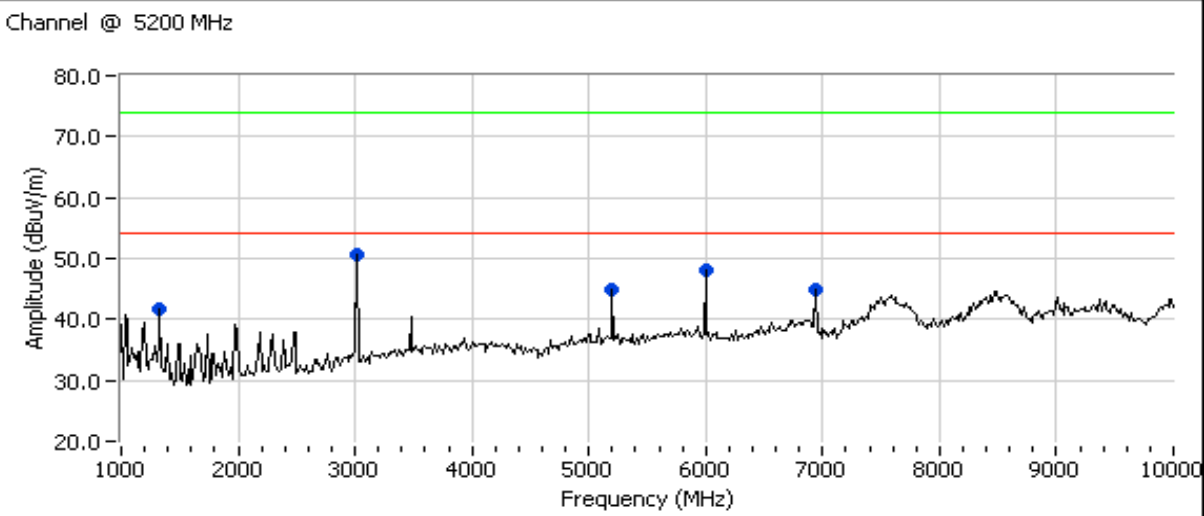

Client: Intel	Job Number: J70979
Model: 512an MMW	T-Log Number: T71043
Contact: Robert Paxman	Account Manager: Briggs / Eriksen
Standard: RSS 210 / FCC 15.407 UNII (Radiated)	Class: Enter on cover sheet

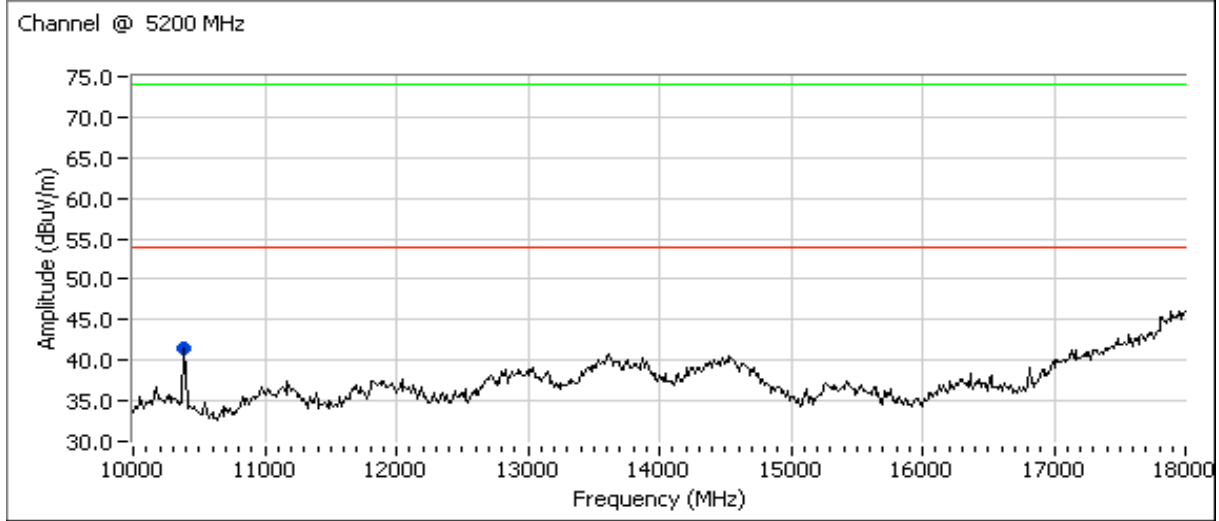

Receiver Tuned to 5280 MHz - All chains active

Frequency MHz	Level dBuV/m	Pol v/h	RSS GEN		Detector Pk/QP/Avg	Azimuth degrees	Height meters	Comments
			Limit	Margin				
1046.155	31.3	H	54.0	-22.7	AVG	136	1.0	
3000.350	50.9	V	54.0	-3.1	AVG	267	1.0	
5279.950	42.2	V	54.0	-11.8	AVG	166	1.5	
6000.770	48.9	V	54.0	-5.1	AVG	261	1.5	
7039.900	43.3	V	54.0	-10.7	AVG	138	1.0	
10559.950	39.4	V	54.0	-14.6	AVG	243	1.0	
1046.155	48.5	H	74.0	-25.5	PK	136	1.0	
3000.350	54.2	V	74.0	-19.8	PK	267	1.0	
5279.950	46.9	V	74.0	-27.1	PK	166	1.5	
6000.770	53.0	V	74.0	-21.0	PK	261	1.5	
7039.900	48.6	V	74.0	-25.4	PK	138	1.0	
10559.950	44.1	V	74.0	-29.9	PK	243	1.0	

Note 1: Above 1 GHz, the limit is for an average measurement. In addition, the peak value of any emission above 1 GHz, can not exceed the average limit by more than 20 dB.

Client: Intel	Job Number: J70979
Model: 512an MMW	T-Log Number: T71043
Contact: Robert Paxman	Account Manager: Briggs / Eriksen
Standard: RSS 210 / FCC 15.407 UNII (Radiated)	Class: Enter on cover sheet

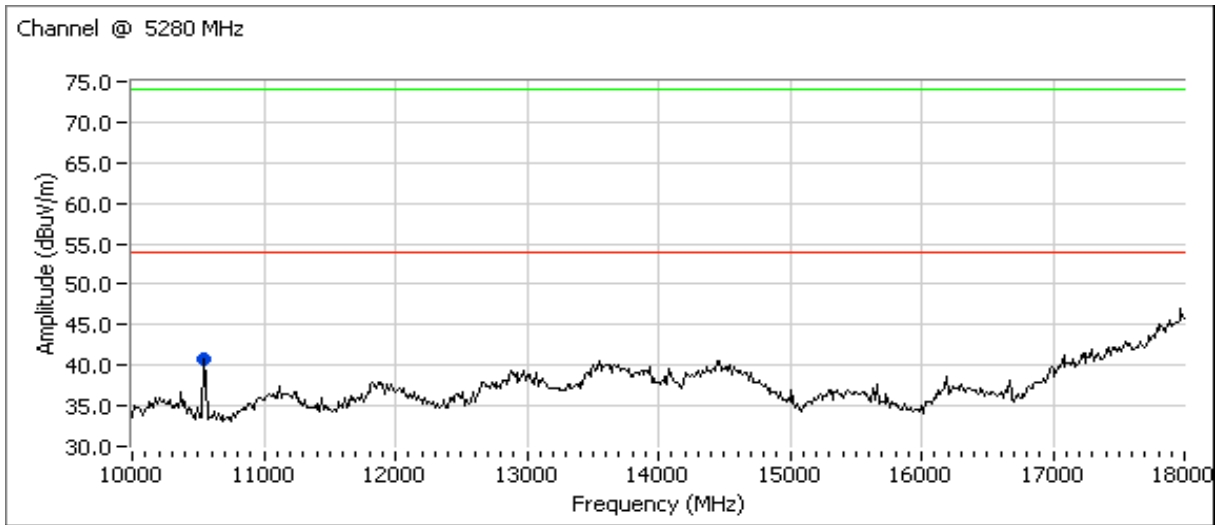
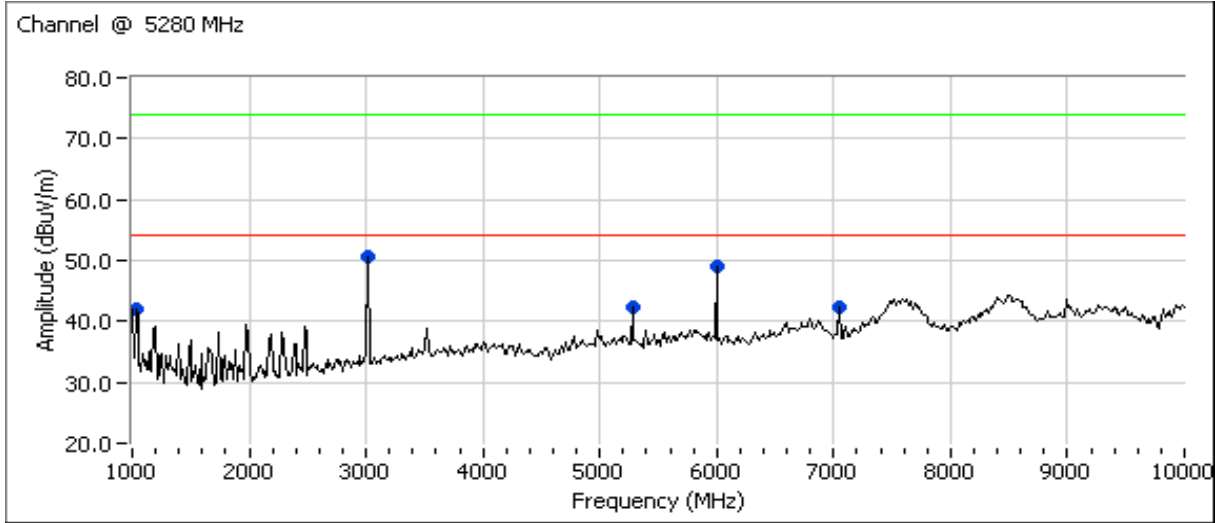

Client: Intel	Job Number: J70979
Model: 512an MMW	T-Log Number: T71043
Contact: Robert Paxman	Account Manager: Briggs / Eriksen
Standard: RSS 210 / FCC 15.407 UNII (Radiated)	Class: Enter on cover sheet

Receiver Tuned to 5600 MHz - All chains active

Frequency MHz	Level dB μ V/m	Pol v/h	RSS GEN		Detector Pk/QP/Avg	Azimuth degrees	Height meters	Comments
			Limit	Margin				
1046.253	31.7	H	54.0	-22.3	AVG	142	1.0	
3000.330	50.9	V	54.0	-3.1	AVG	267	1.0	
3733.310	39.4	V	54.0	-14.6	AVG	222	1.0	
6000.720	49.2	V	54.0	-4.8	AVG	264	1.5	
7466.730	49.1	V	54.0	-4.9	AVG	152	1.5	
1046.253	49.8	H	74.0	-24.2	PK	142	1.0	
3000.330	54.2	V	74.0	-19.8	PK	267	1.0	
3733.310	45.1	V	74.0	-28.9	PK	222	1.0	
6000.720	52.8	V	74.0	-21.2	PK	264	1.5	
7466.730	53.5	V	74.0	-20.5	PK	152	1.5	

Note 1: Above 1 GHz, the limit is for an average measurement. In addition, the peak value of any emission above 1 GHz, can not exceed the average limit by more than 20 dB.

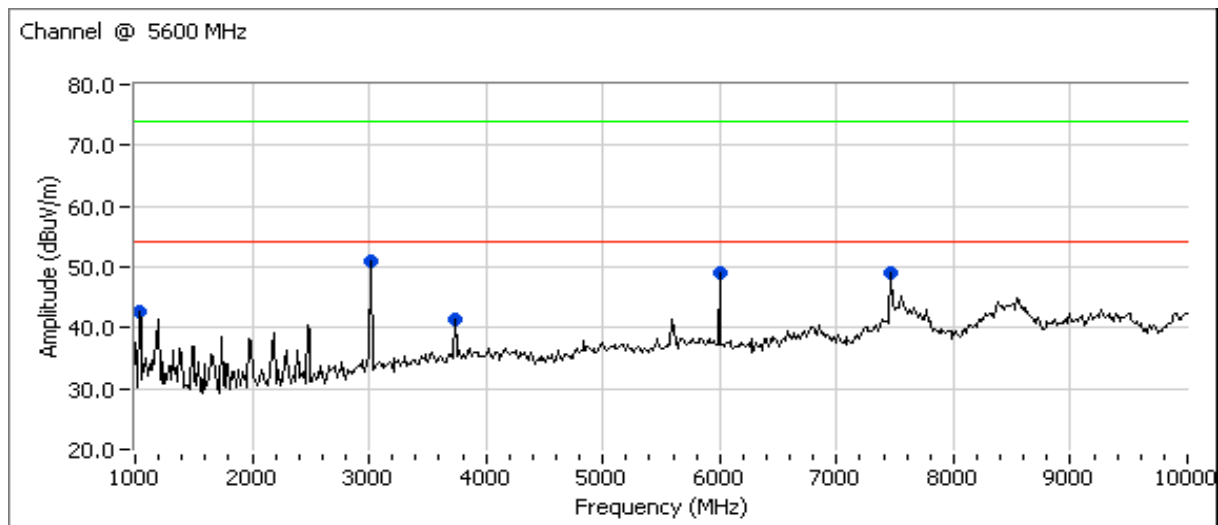

No emissions from 10 - 18GHz

Client:	Intel	Job Number:	J70979
Model:	512an MMW	T-Log Number:	T71043
Contact:	Robert Paxman	Account Manager:	Briggs / Eriksen
Standard:	RSS 210 / FCC 15.407 UNII (Radiated)	Class:	N/A

RSS 210 and FCC 15.E (U-NII, 5150- 550/5250-5350/5460-5725MHz) Radiated Spurious Emissions - Band Edge 802.11a Mode

Test Specific Details

Objective: The objective of this test session is to perform final qualification testing of the EUT with respect to the specification listed above.

Date of Test: 3/17/2008
 Test Engineer: Ben Jing
 Test Location: FT Chamber # 4

Config. Used: 1
 Config Change: None
 Host Unit Voltage 120V/60Hz

General Test Configuration

The EUT and all local support equipment were located on the turntable for radiated spurious emissions testing. All remote support equipment was located approximately 30 meters from the EUT with all I/O connections running on top of the groundplane.

For radiated emissions testing the measurement antenna was located 3 meters from the EUT.

Ambient Conditions: Temperature: 20 °C
 Rel. Humidity: 39 %

Summary of Results

Run #	Mode	Channel	Power Setting	Measured Power	Test Performed	Limit	Result / Margin
1a	802.11a Chain A	5180MHz	GC = 27	AP = 18.4	Band Edge radiated field strength	FCC Part 15.209	52.7 dBuV/m @ 5149.9 MHz (-1.3dB)
1b	802.11a Chain A	5320MHz	GC = 24.5	AP = 16.6	Band Edge radiated field strength	FCC Part 15.209	52.3dBuV/m @ 5350.0 MHz (-1.7dB)
1c	802.11a Chain A	5500MHz	GC = 28	AP = 19.1	Band Edge radiated field strength	FCC Part 15.209 / 15E	52.1 dBuV/m @ 5459.95MHz (-1.9dB)

Modifications Made During Testing

No modifications were made to the EUT during testing

Deviations From The Standard

No deviations were made from the requirements of the standard.

Client: Intel	Job Number: J70979
Model: 512an MMW	T-Log Number: T71043
Contact: Robert Paxman	Account Manager: Briggs / Eriksen
Standard: RSS 210 / FCC 15.407 UNII (Radiated)	Class: N/A

Run #1: Radiated Spurious Emissions, Band Edges. Operating Mode: 802.11a - Chain A

Run #1a: Low Channel @ 5180 MHz (band edge at 5150 MHz)

Power Setting: GC = 27 Average power: AP = 18.4 (for reference purposes)

Fundamental Signal Field Strength: Peak and average values measured in 1 MHz, for reference only

Frequency	Level	Pol	15.209 / 15.247		Detector	Azimuth	Height	Comments
MHz	dB μ V/m	v/h	Limit	Margin	Pk/QP/Avg	degrees	meters	
5181.150	94.9	V	-	-	AVG	214	1.0	RB = 1MHz, VB = 10Hz
5181.150	103.9	V	-	-	PK	214	1.0	RB = VB = 1MHz
5181.310	97.8	H	-	-	AVG	44	1.0	RB = 1MHz, VB = 10Hz
5181.310	106.1	H	-	-	PK	44	1.0	RB = VB = 1MHz

Band Edge Signal Field Strength

Frequency	Level	Pol	15.209 / 15.247		Detector	Azimuth	Height	Comments
MHz	dB μ V/m	v/h	Limit	Margin	Pk/QP/Avg	degrees	meters	
5149.940	69.1	H	74.0	-4.9	PK	48	1.0	GC = 27 , AP = 18.4
5149.960	52.7	H	54.0	-1.3	AVG	48	1.0	GC = 27 , AP = 18.4

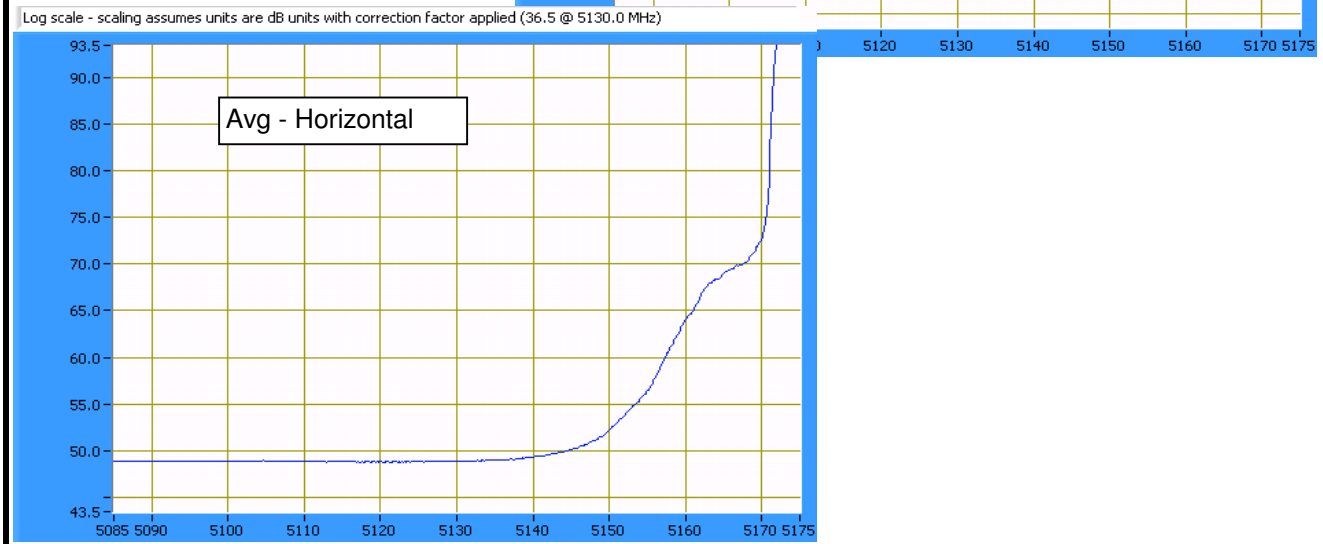
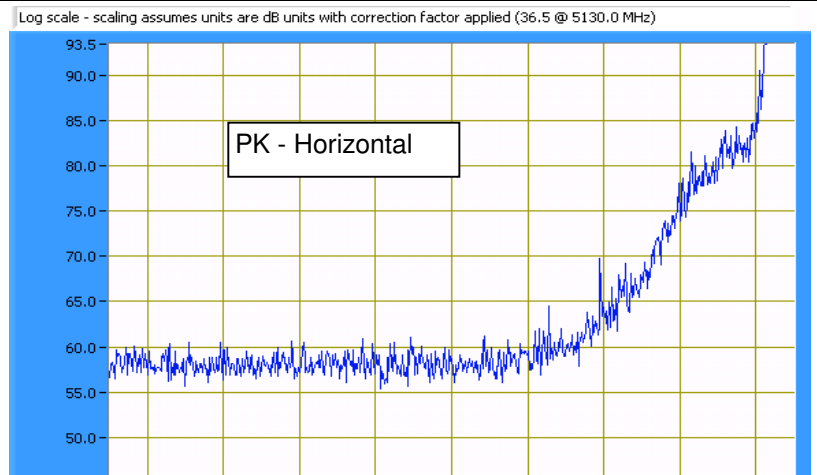

Client: Intel	Job Number: J70979
Model: 512an MMW	T-Log Number: T71043
Contact: Robert Paxman	Account Manager: Briggs / Eriksen
Standard: RSS 210 / FCC 15.407 UNII (Radiated)	Class: N/A

Run #1b: High Channel @ 5320 MHz (band edge at 5350 MHz)

Power Setting: GC = 24.5 Average power: AP = 16.6 (for reference purposes)

Fundamental Signal Field Strength: Peak and average values measured in 1 MHz, for reference only

Frequency MHz	Level dB μ V/m	Pol v/h	15.209 / 15.247		Detector Pk/QP/Avg	Azimuth degrees	Height meters	Comments
			Limit	Margin				
5321.480	96.0	H	-	-	AVG	61	1.0	RB = 1MHz, VB = 10Hz
5321.480	104.1	H	-	-	PK	61	1.0	RB = VB = 1MHz
5318.830	98.5	V	-	-	AVG	96	1.0	RB = 1MHz, VB = 10Hz
5318.830	106.6	V	-	-	PK	96	1.0	RB = VB = 1MHz

Band Edge Signal Field Strength

Restricted band starts at allocated band edge (5350MHz), field strength limit is 54dBuV/m average, 74dBuV/m peak.

Frequency MHz	Level dB μ V/m	Pol v/h	15.209 / 15.247		Detector Pk/QP/Avg	Azimuth degrees	Height meters	Comments
			Limit	Margin				
5350.060	68.1	V	74.0	-5.9	PK	96	1.0	GC = 24.5 , AP = 16.6
5350.060	52.3	V	54.0	-1.7	AVG	96	1.0	GC = 24.5 , AP = 16.6

Log scale - scaling assumes units are dB units with correction factor applied (36.8 @ 5360.0 MHz)

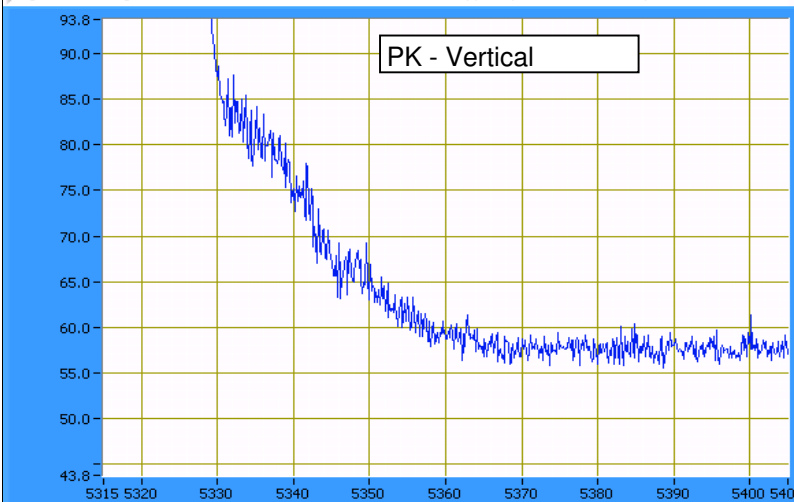

bits with correction factor applied (36.8 @ 5360.0 MHz)

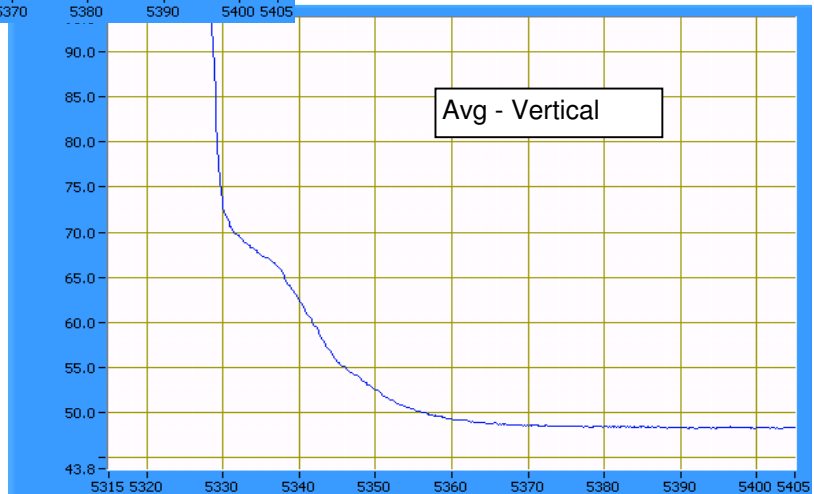

Client: Intel	Job Number: J70979
Model: 512an MMW	T-Log Number: T71043
Contact: Robert Paxman	Account Manager: Briggs / Eriksen
Standard: RSS 210 / FCC 15.407 UNII (Radiated)	Class: N/A

Run #1c: Low Channel @ 5500 MHz (restricted band edge at 5460 MHz, allocated band edge at 5470MHz)

Power Setting: GC = 28 Average power: AP = 19.1 (for reference purposes)

Fundamental Signal Field Strength: Peak and average values measured in 1 MHz, for reference only

Frequency MHz	Level dB μ V/m	Pol v/h	15.209 / 15.247		Detector Pk/QP/Avg	Azimuth degrees	Height meters	Comments
			Limit	Margin				
5500.960	99.7	V	-	-	AVG	163	1.0	RB = 1MHz, VB = 10Hz
5500.960	107.9	V	-	-	PK	163	1.0	RB = VB = 1MHz
5498.790	92.9	H	-	-	AVG	41	1.0	RB = 1MHz, VB = 10Hz
5498.790	100.7	H	-	-	PK	41	1.0	RB = VB = 1MHz

5460 Restricted Band Feld strength limit = 54dBuV/m avg, 74dBuV/m peak at 3m

5460 - 5470 MHz, verified via conducted measurements.

Frequency MHz	Level dB μ V/m	Pol v/h	15.209 / 15.247		Detector Pk/QP/Avg	Azimuth degrees	Height meters	Comments
			Limit	Margin				
5459.940	69.1	V	74.0	-4.9	PK	145	1.0	GC = 28 , AP = 19.1
5459.940	52.1	V	54.0	-1.9	AVG	144	1.0	GC = 28 , AP = 19.1

Log scale - scaling assumes units are dB units with correction factor applied (36.9 @ 5450.0 MHz)

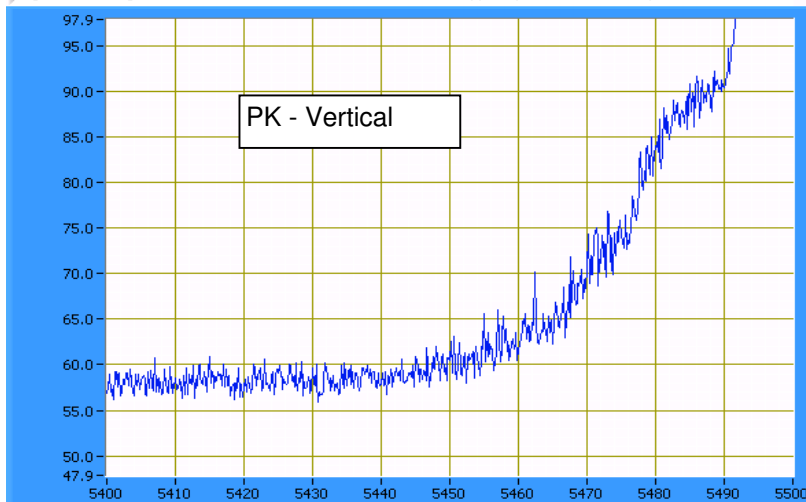

Log scale - scaling assumes units are dB units with correction factor applied (36.9 @ 5450.0 MHz)

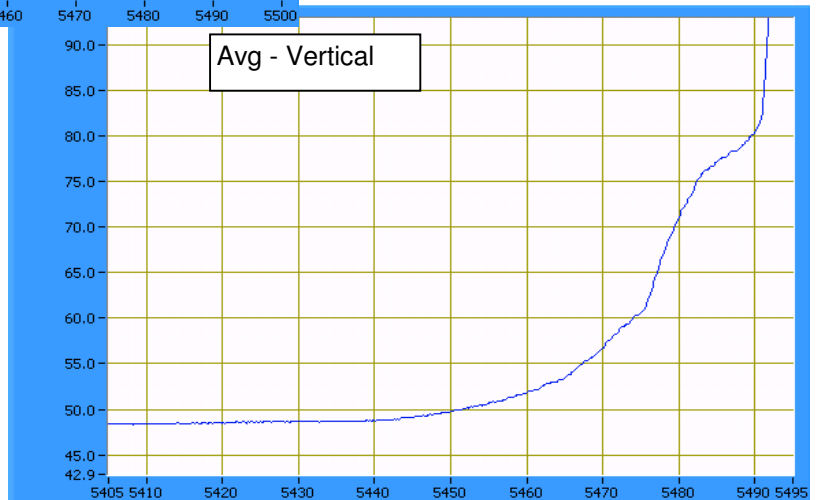

Client:	Intel	Job Number:	J70979
Model:	512an MMW	T-Log Number:	T71043
		Account Manager:	Briggs / Eriksen
Contact:	Robert Paxman		
Standard:	RSS 210 / FCC 15.407 UNII (Radiated)	Class:	N/A

**RSS 210 and FCC 15.247 (DTS, 2400 - 2483.5 MHz)
Radiated Spurious Emissions, 1 - 40GHz 802.11a Mode**

Test Specific Details

Objective: The objective of this test session is to perform final qualification testing of the EUT with respect to the specification listed above.

Date of Test: 3/21/2008
Test Engineer: Ben Jing
Test Location: Fremont Chamber # 4

Config. Used: 1
Config Change: None
Host Unit Voltage 120V/60Hz

General Test Configuration

The EUT and all local support equipment were located on the turntable for radiated spurious emissions testing. All remote support equipment was located approximately 30 meters from the EUT with all I/O connections running on top of the groundplane.

For radiated emissions testing the measurement antenna was located 3 meters from the EUT.

Ambient Conditions:

Temperature:	20 °C
Rel. Humidity:	34 %

Modifications Made During Testing

No modifications were made to the EUT during testing

Deviations From The Standard

No deviations were made from the requirements of the standard.

Client:	Intel	Job Number:	J70979
Model:	512an MMW	T-Log Number:	T71043
Contact:	Robert Paxman	Account Manager:	Briggs / Eriksen
Standard:	RSS 210 / FCC 15.407 UNII (Radiated)	Class:	N/A

Summary of Results

Run #	Mode	Channel	Power Setting	Measured Power	Test Performed	Limit	Result / Margin
1a	802.11a Chain A	5180	GC = 27.5	AP = 16.5	Radiated Emissions, 1 - 26 GHz	FCC Part 15.209 / 15.247(c)	39.3dBµV/m @ 20714.6MHz (-14.7dB)
1b	802.11a Chain A	5200	GC = 27.5	AP = 16.6	Radiated Emissions, 1 - 26 GHz	FCC Part 15.209 / 15.247(c)	38.8dBµV/m @ 20804.4MHz (-15.2dB)
1c	802.11a Chain A	5240	GC = 26.5	AP = 16.6	Radiated Emissions, 1 - 26 GHz	FCC Part 15.209 / 15.247(c)	53.9dBµV/m @ 10481.7MHz (-14.4dB)
2a	802.11a Chain A	5260	GC = 26	AP = 16.5	Radiated Emissions, 1 - 26 GHz	FCC Part 15.209 / 15.247(c)	44.2dBµV/m @ 21044.2MHz (-9.8dB)
2b	802.11a Chain A	5280	GC = 25.5	AP = 16.5	Radiated Emissions, 1 - 26 GHz	FCC Part 15.209 / 15.247(c)	45.2dBµV/m @ 21117.7MHz (-8.8dB)
2c	802.11a Chain A	5320	GC = 24.5	AP = 16.6	Radiated Emissions, 1 - 26 GHz	FCC Part 15.209 / 15.247(c)	48.1dBµV/m @ 10639.8MHz (-5.9dB)
3a	802.11a Chain A	5500	GC = 24.5	AP = 16.6	Radiated Emissions, 1 - 26 GHz	FCC Part 15.209 / 15.247(c)	50.6dBµV/m @ 10999.8MHz (-3.4dB)
3b	802.11a Chain A	5600	GC = 25	AP = 16.6	Radiated Emissions, 1 - 26 GHz	FCC Part 15.209 / 15.247(c)	51.3dBµV/m @ 11202.0MHz (-2.7dB)
3c	802.11a Chain A	5700	GC = 26	AP = 16.5	Radiated Emissions, 1 - 26 GHz	FCC Part 15.209 / 15.247(c)	48.3dBµV/m @ 11399.9MHz (-5.7dB)

Run #1: Radiated Spurious Emissions, 1000 - 40000 MHz. Operating Mode: 802.11a Chain A

Run #1a: Low Channel @ 5180 MHz

Spurious Emissions

Frequency	Level	Pol	15.209 / 15.247		Detector	Azimuth	Height	Comments
MHz	dBµV/m	v/h	Limit	Margin	Pk/QP/Avg	degrees	meters	
3000.350	49.7	V	68.3	-18.6	AVG	264	1.5	Note 2
6000.710	48.8	V	68.3	-19.5	AVG	270	1.5	Note 2
6906.650	48.1	V	68.3	-20.2	AVG	64	1.5	Note 2
10359.950	53.3	V	68.3	-15.0	AVG	125	1.0	Note 2
20714.580	39.3	V	54.0	-14.7	AVG	161	1.0	
3000.350	53.0	V	88.3	-35.3	PK	264	1.5	Note 2
6000.710	51.9	V	88.3	-36.4	PK	270	1.5	Note 2
6906.650	50.9	V	88.3	-37.4	PK	64	1.5	Note 2
10359.950	66.0	V	88.3	-22.3	PK	125	1.0	Note 2
20714.580	53.1	V	74.0	-20.9	PK	161	1.0	

Note 1: For emissions in restricted bands, the limit of 15.209 was used. For all other emissions, the limit was set to -27dBm eirp (68.3dBuV/m average, 88.3dBuV/m peak)

Note 2: Signal is not in a restricted band

Client: Intel	Job Number: J70979
Model: 512an MMW	T-Log Number: T71043
Contact: Robert Paxman	Account Manager: Briggs / Eriksen
Standard: RSS 210 / FCC 15.407 UNII (Radiated)	Class: N/A

802.11a Channel @ 5180 MHz

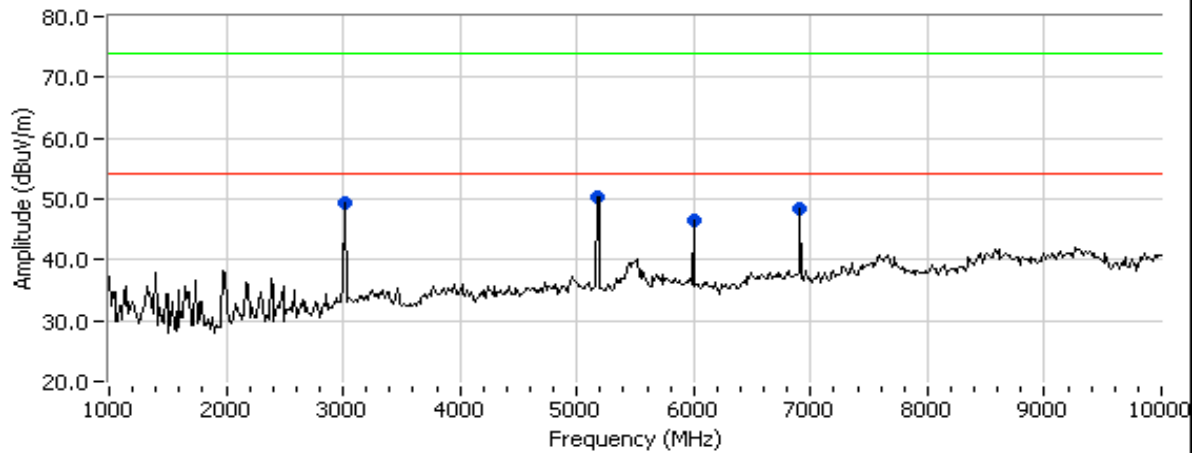

802.11a Channel @ 5180 MHz

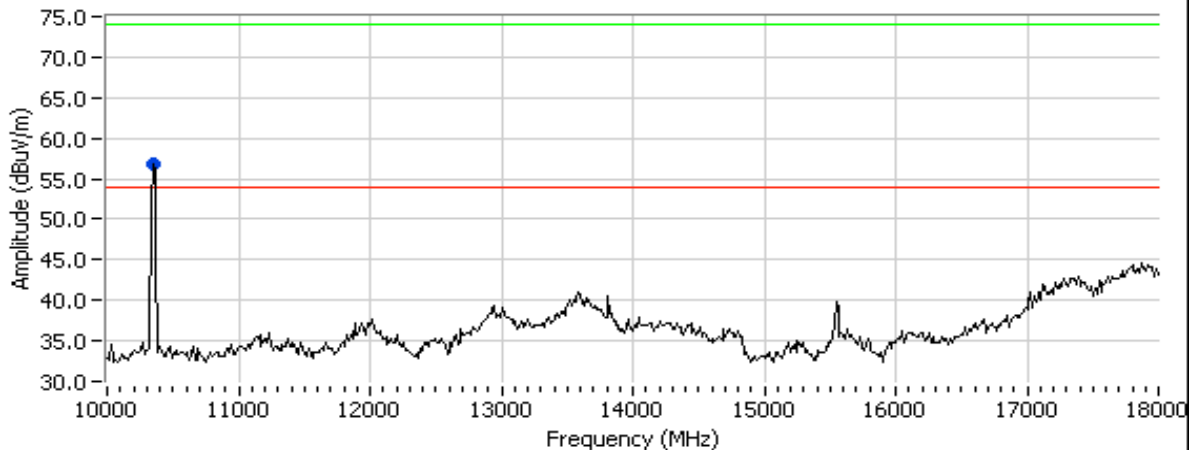

Client: Intel	Job Number: J70979
Model: 512an MMW	T-Log Number: T71043
Contact: Robert Paxman	Account Manager: Briggs / Eriksen
Standard: RSS 210 / FCC 15.407 UNII (Radiated)	Class: N/A

802.11a Channel @ 5180 MHz

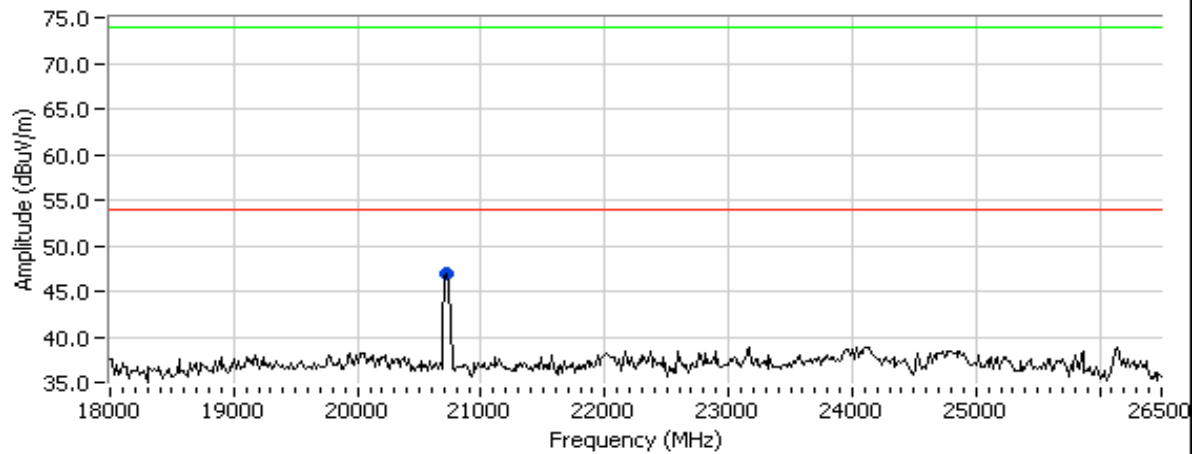

802.11a Channel @ 5180 MHz

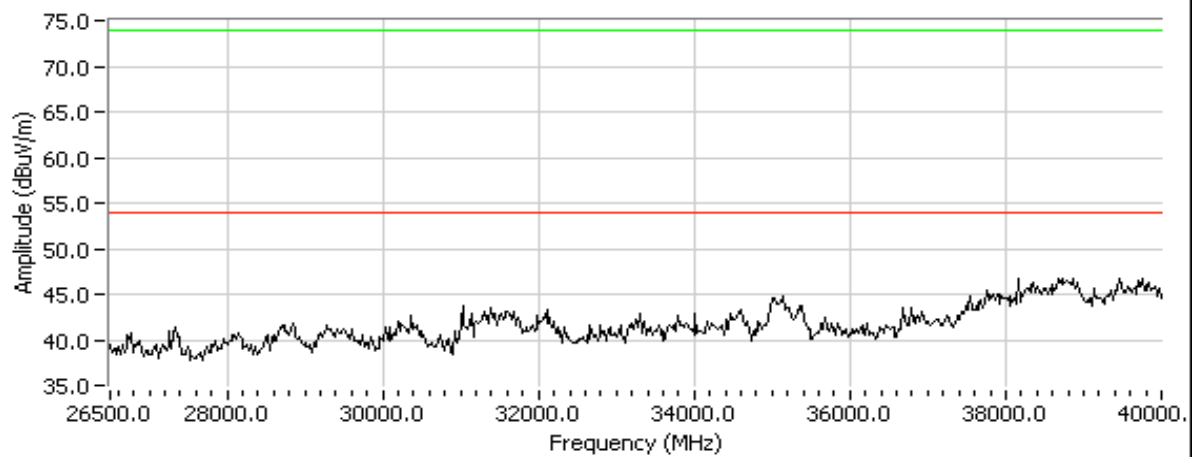

Client: Intel	Job Number: J70979
Model: 512an MMW	T-Log Number: T71043
Contact: Robert Paxman	Account Manager: Briggs / Eriksen
Standard: RSS 210 / FCC 15.407 UNII (Radiated)	Class: N/A

Run #1b: Center Channel @ 5200 MHz

Spurious Emissions

Frequency MHz	Level dB μ V/m	Pol v/h	15.209 / 15.247		Detector Pk/QP/Avg	Azimuth degrees	Height meters	Comments
			Limit	Margin				
3000.350	49.3	V	68.3	-19.0	AVG	274	1.0	Note 2
6000.720	46.0	V	68.3	-22.3	AVG	160	1.0	Note 2
6933.310	46.8	V	68.3	-21.5	AVG	150	1.0	Note 2
10399.940	44.0	V	68.3	-24.3	AVG	254	1.0	Note 2
20804.360	38.8	V	54.0	-15.2	AVG	161	1.0	
3000.350	53.5	V	88.3	-34.8	PK	274	1.0	Note 2
6000.720	49.9	V	88.3	-38.4	PK	160	1.0	Note 2
6933.310	50.1	V	88.3	-38.2	PK	150	1.0	Note 2
10399.940	55.9	V	88.3	-32.4	PK	254	1.0	Note 2
20804.360	51.9	V	74.0	-22.1	PK	161	1.0	

Note 1: For emissions in restricted bands, the limit of 15.209 was used. For all other emissions, the limit was set to -27dBm eirp (68.3dB μ V/m average, 88.3dB μ V/m peak)

Note 2: Signal is not in a restricted band.

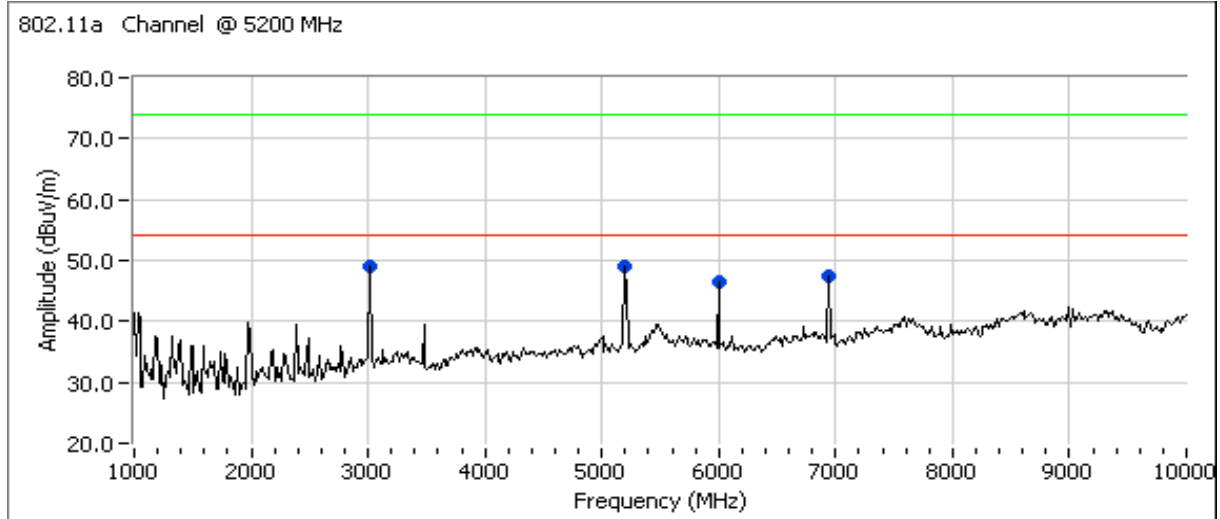

Client: Intel	Job Number: J70979
Model: 512an MMW	T-Log Number: T71043
Contact: Robert Paxman	Account Manager: Briggs / Eriksen
Standard: RSS 210 / FCC 15.407 UNII (Radiated)	Class: N/A

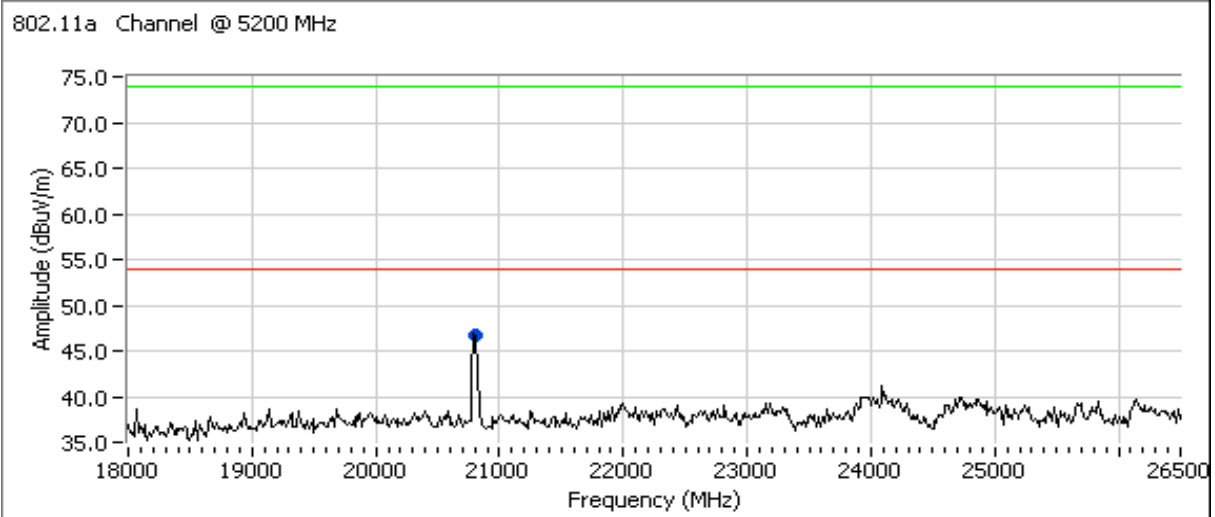
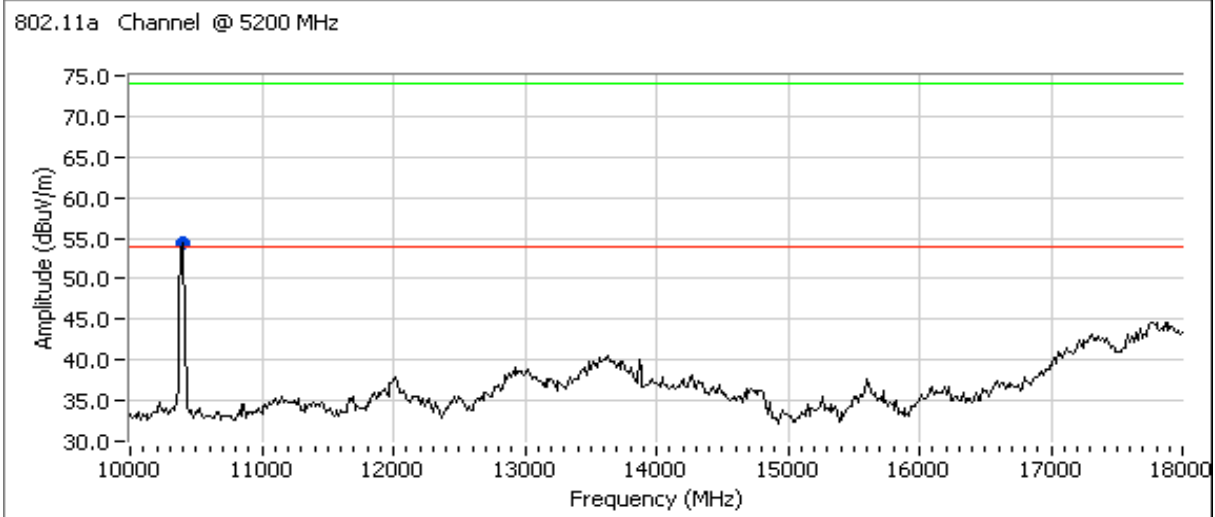

Plot 26 - 40GHz not included ... no emissions observed.

Client:	Intel	Job Number:	J70979
Model:	512an MMW	T-Log Number:	T71043
Contact:	Robert Paxman	Account Manager:	Briggs / Eriksen
Standard:	RSS 210 / FCC 15.407 UNII (Radiated)	Class:	N/A

Run #1c: High Channel @ 5240 MHz
Spurious Emissions

Frequency MHz	Level dB μ V/m	Pol v/h	15.209 / 15.247		Detector Pk/QP/Avg	Azimuth degrees	Height meters	Comments
			Limit	Margin				
3000.320	50.3	V	68.3	-18.0	AVG	265	1.5	Note 2
6000.670	46.3	V	68.3	-22.0	AVG	112	1.0	Note 2
6986.610	52.0	V	68.3	-16.3	AVG	179	1.0	Note 2
10481.710	53.9	V	68.3	-14.4	AVG	131	1.0	Note 2
20795.200	36.9	V	54.0	-17.1	AVG	160	1.0	
3000.320	53.8	V	88.3	-34.5	PK	265	1.5	Note 2
6000.670	49.9	V	88.3	-38.4	PK	112	1.0	Note 2
6986.610	53.9	V	88.3	-34.4	PK	179	1.0	Note 2
10481.710	65.9	V	88.3	-22.4	PK	131	1.0	Note 2
20795.200	50.9	V	74.0	-23.1	PK	160	1.0	

Note 1: For emissions in restricted bands, the limit of 15.209 was used. For all other emissions, the limit was set to -27dBm eirp (68.3dBuV/m average, 88.3dBuV/m peak)

Note 2: Signal is not in a restricted band.

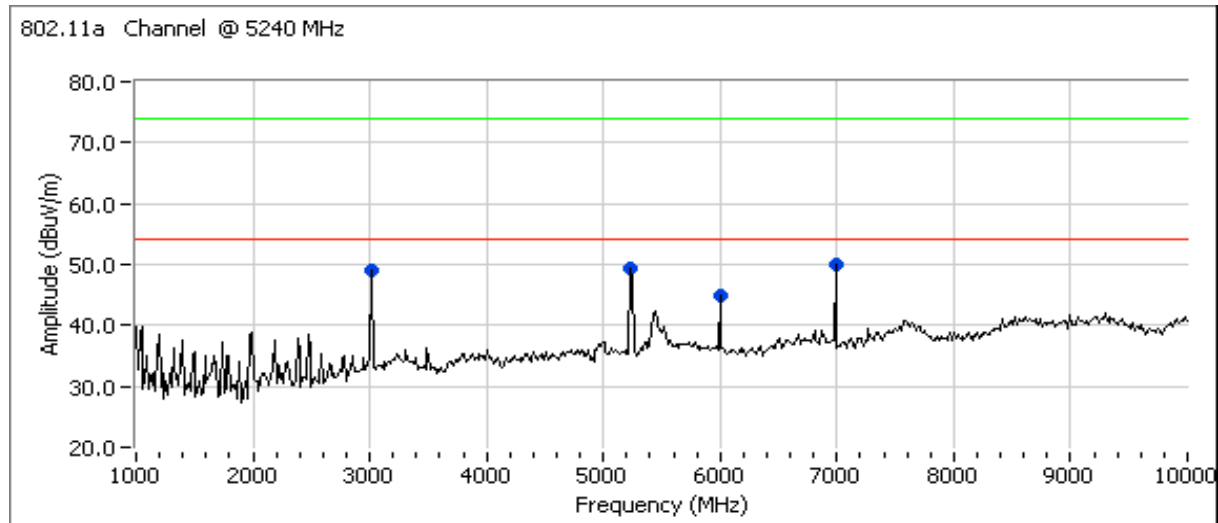

Client: Intel	Job Number: J70979
Model: 512an MMW	T-Log Number: T71043
Contact: Robert Paxman	Account Manager: Briggs / Eriksen
Standard: RSS 210 / FCC 15.407 UNII (Radiated)	Class: N/A

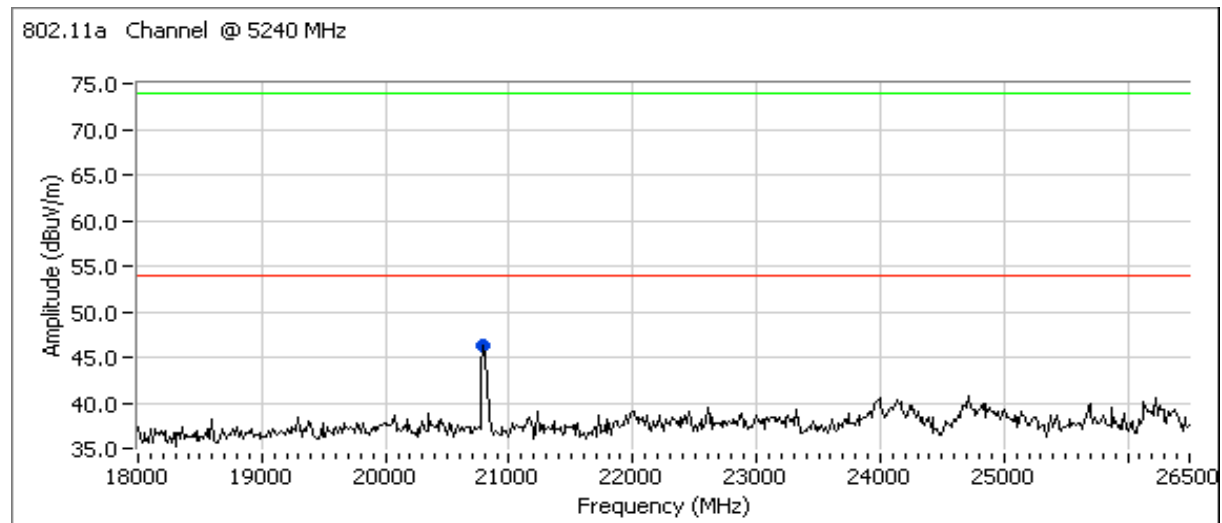
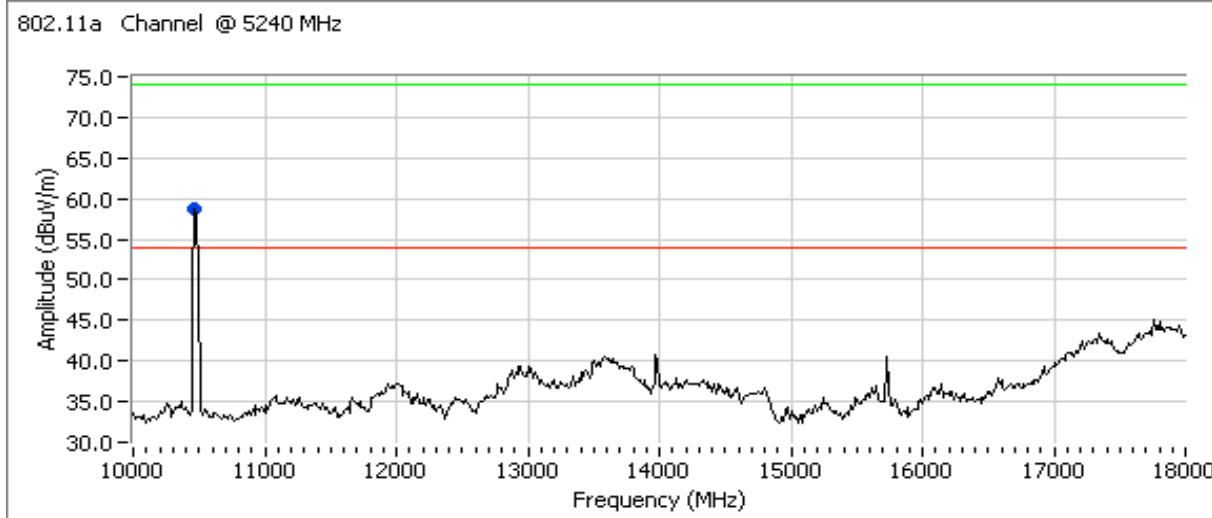

Plot 26 - 40GHz not included ... no emissions observed.

Client: Intel	Job Number: J70979
Model: 512an MMW	T-Log Number: T71043
Contact: Robert Paxman	Account Manager: Briggs / Eriksen
Standard: RSS 210 / FCC 15.407 UNII (Radiated)	Class: N/A

Run #2: Radiated Spurious Emissions, 1000 - 40000 MHz. Operating Mode: 802.11a Chain A

Run #2a: Low Channel @ 5260 MHz

Spurious Emissions

Frequency MHz	Level dB μ V/m	Pol v/h	15.209 / 15.247		Detector Pk/QP/Avg	Azimuth degrees	Height meters	Comments
			Limit	Margin				
3000.360	50.6	V	68.3	-17.7	AVG	264	1.5	Note 2
6000.750	47.5	V	68.3	-20.8	AVG	270	1.5	Note 2
7013.270	51.1	V	68.3	-17.2	AVG	147	2.0	Note 2
10521.840	49.8	V	68.3	-18.5	AVG	238	1.0	Note 2
21044.240	44.2	V	54.0	-9.8	AVG	162	1.0	
3000.360	54.2	V	88.3	-34.1	PK	264	1.5	Note 2
6000.750	51.5	V	88.3	-36.8	PK	270	1.5	Note 2
7013.270	53.2	V	88.3	-35.1	PK	147	2.0	Note 2
10521.840	62.0	V	88.3	-26.3	PK	238	1.0	Note 2
21044.240	57.2	V	74.0	-16.8	PK	162	1.0	

Note 1: For emissions in restricted bands, the limit of 15.209 was used. For all other emissions, the limit was set to -27dBm eirp (68.3dBuV/m average, 88.3dBuV/m peak)

Note 2: Signal is not in a restricted band.

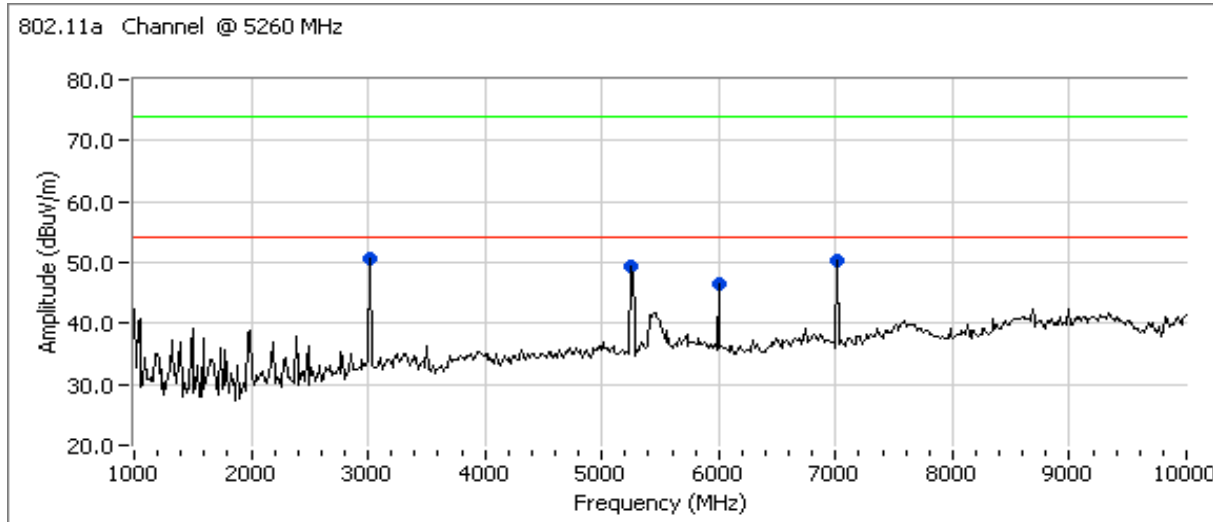

Client: Intel	Job Number: J70979
Model: 512an MMW	T-Log Number: T71043
Contact: Robert Paxman	Account Manager: Briggs / Eriksen
Standard: RSS 210 / FCC 15.407 UNII (Radiated)	Class: N/A

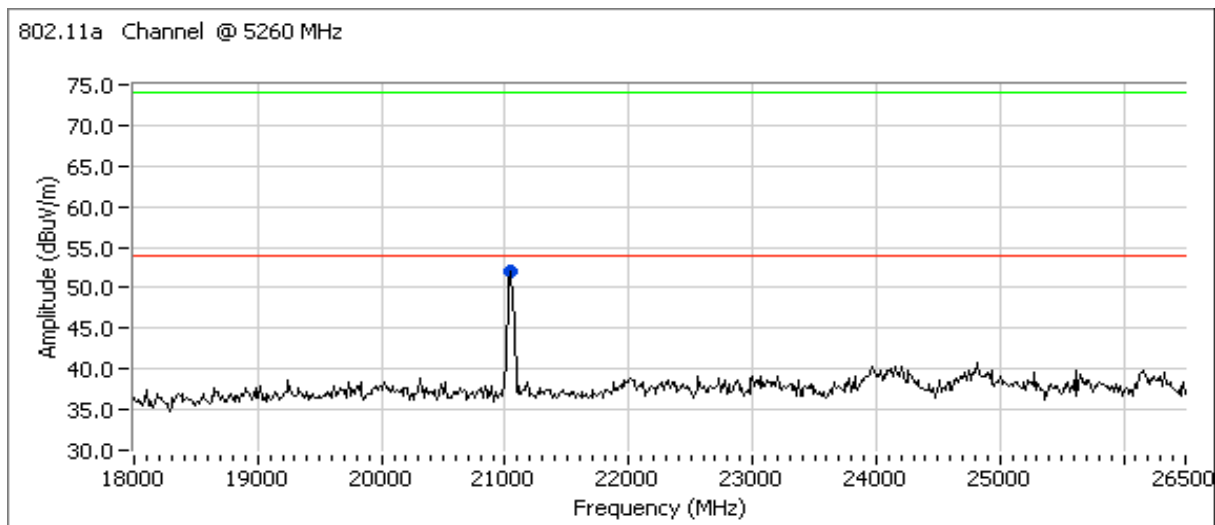
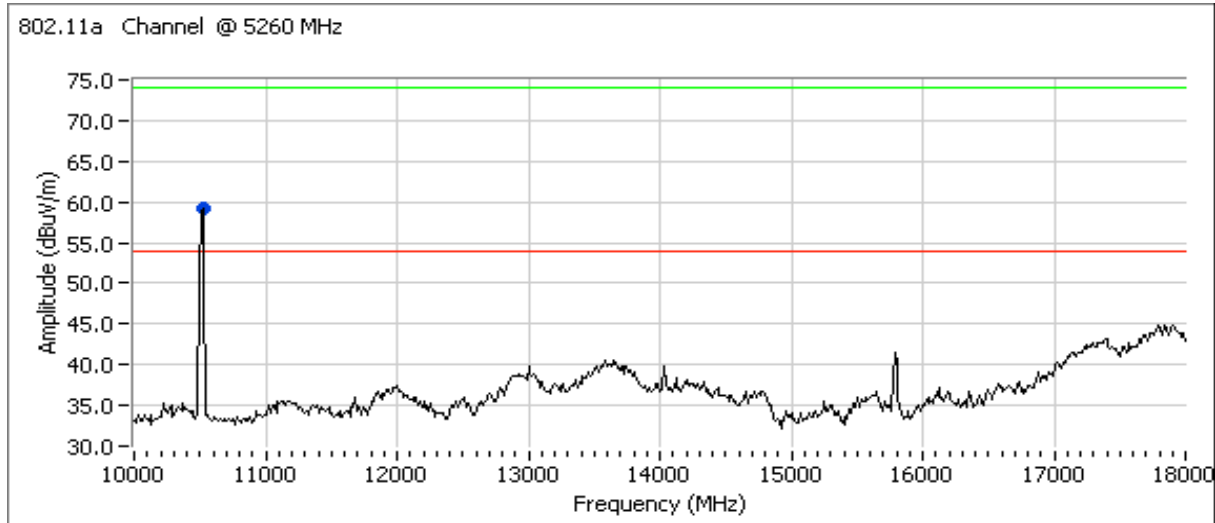

Plot 26 - 40GHz not included ... no emissions observed.

Client:	Intel	Job Number:	J70979
Model:	512an MMW	T-Log Number:	T71043
Contact:	Robert Paxman	Account Manager:	Briggs / Eriksen
Standard:	RSS 210 / FCC 15.407 UNII (Radiated)	Class:	N/A

Run #2b: Center Channel @ 5280 MHz
Spurious Emissions

Frequency MHz	Level dB μ V/m	Pol v/h	15.209 / 15.247		Detector Pk/QP/Avg	Azimuth degrees	Height meters	Comments
			Limit	Margin				
3000.370	50.8	V	68.3	-17.5	AVG	265	1.5	Note 2
6000.800	48.0	V	68.3	-20.3	AVG	268	1.5	Note 2
7039.950	47.3	V	68.3	-21.0	AVG	170	2.0	Note 2
10561.980	52.7	V	68.3	-15.6	AVG	122	1.0	Note 2
21117.670	45.2	V	54.0	-8.8	AVG	161	1.0	
3000.370	54.0	V	88.3	-34.3	PK	265	1.5	Note 2
6000.800	51.2	V	88.3	-37.1	PK	268	1.5	Note 2
7039.950	51.2	V	88.3	-37.1	PK	170	2.0	Note 2
10561.980	64.7	V	88.3	-23.6	PK	122	1.0	Note 2
21117.670	58.2	V	74.0	-15.8	PK	161	1.0	

Note 1: For emissions in restricted bands, the limit of 15.209 was used. For all other emissions, the limit was set to -27dBm eirp (68.3dBuV/m average, 88.3dBuV/m peak)

Note 2: Signal is not in a restricted band.

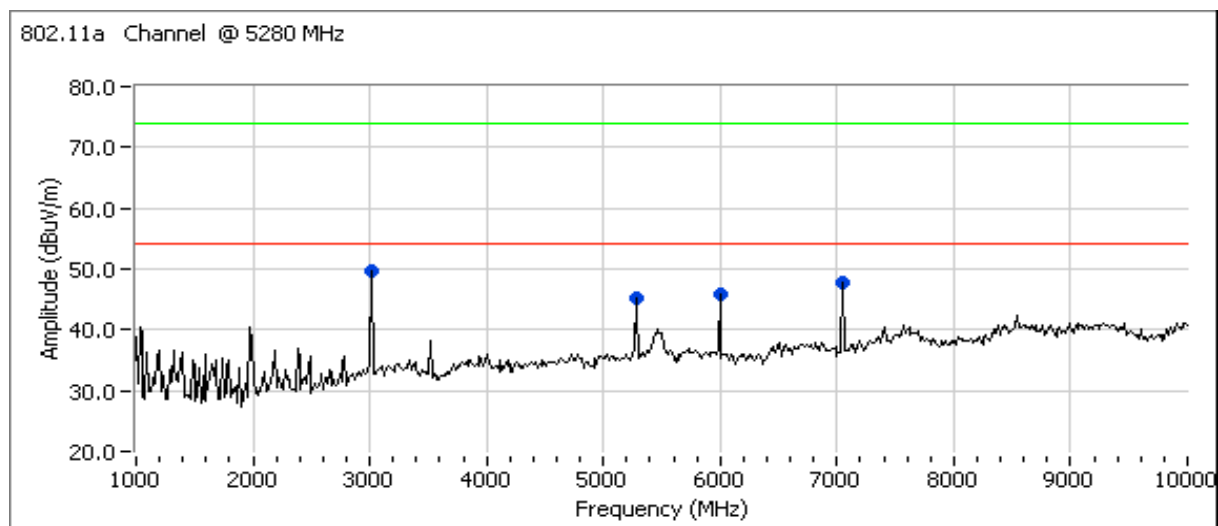

Client: Intel	Job Number: J70979
Model: 512an MMW	T-Log Number: T71043
Contact: Robert Paxman	Account Manager: Briggs / Eriksen
Standard: RSS 210 / FCC 15.407 UNII (Radiated)	Class: N/A

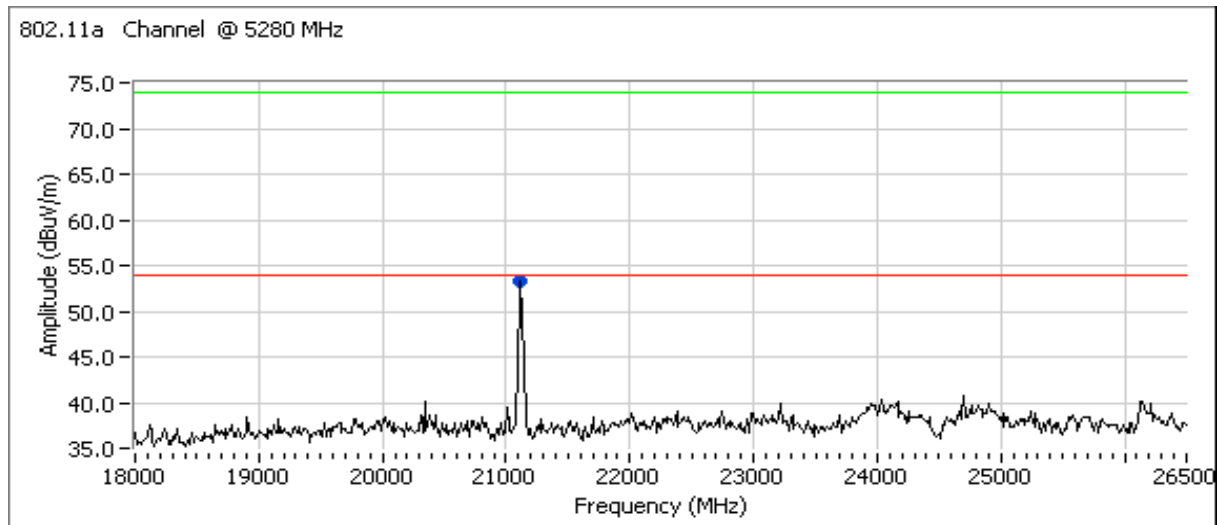
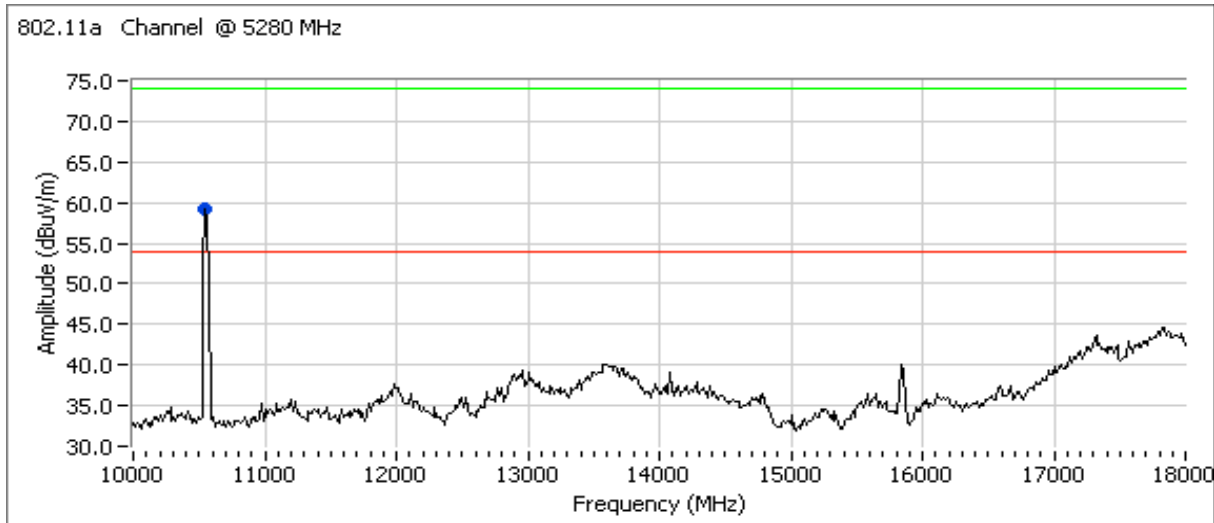

Plot 26 - 40GHz not included ... no emissions observed.

Client:	Intel	Job Number:	J70979
Model:	512an MMW	T-Log Number:	T71043
Contact:	Robert Paxman	Account Manager:	Briggs / Eriksen
Standard:	RSS 210 / FCC 15.407 UNII (Radiated)	Class:	N/A

Run #2c: High Channel @ 5320 MHz
Spurious Emissions

Frequency MHz	Level dB μ V/m	Pol v/h	15.209 / 15.247		Detector Pk/QP/Avg	Azimuth degrees	Height meters	Comments
			Limit	Margin				
3000.390	48.9	V	68.3	-19.4	AVG	272	1.0	Note 2
6000.670	45.8	V	68.3	-22.5	AVG	105	1.0	Note 2
7093.320	39.2	V	68.3	-29.1	AVG	229	1.0	Note 2
10639.810	48.1	V	54.0	-5.9	AVG	120	1.0	
21277.590	40.2	V	54.0	-13.8	AVG	170	1.0	
3000.390	52.4	V	88.3	-35.9	PK	272	1.0	Note 2
6000.670	49.5	V	88.3	-38.8	PK	105	1.0	Note 2
7093.320	45.9	V	88.3	-42.4	PK	229	1.0	Note 2
10639.810	60.6	V	74.0	-13.4	PK	120	1.0	
21277.590	53.7	V	74.0	-20.3	PK	170	1.0	

Note 1: For emissions in restricted bands, the limit of 15.209 was used. For all other emissions, the limit was set to -27dBm eirp (68.3dBuV/m average, 88.3dBuV/m peak)

Note 2: Signal is not in a restricted band.

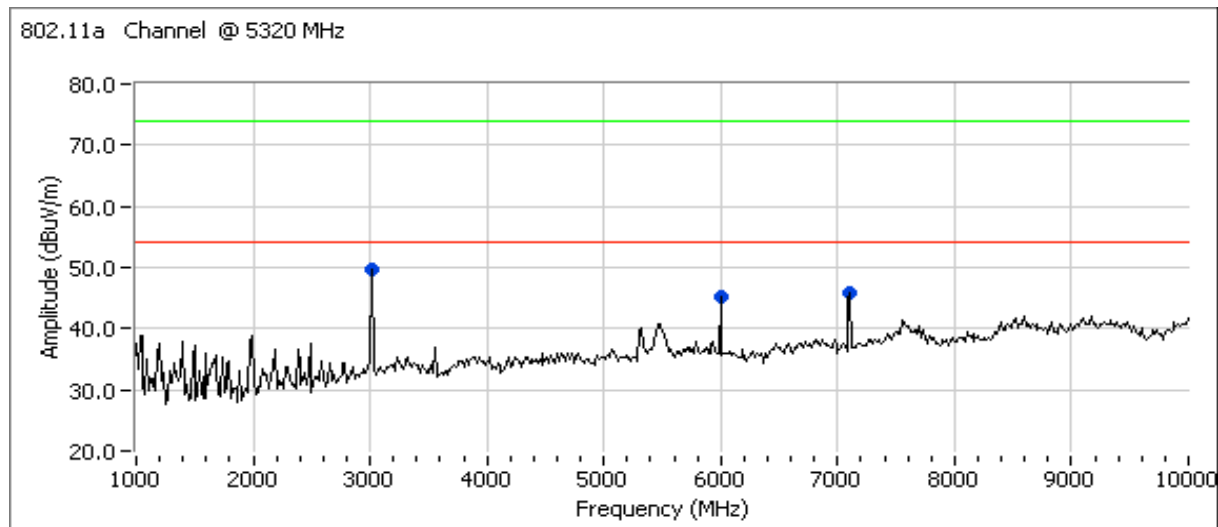

Client: Intel	Job Number: J70979
Model: 512an MMW	T-Log Number: T71043
Contact: Robert Paxman	Account Manager: Briggs / Eriksen
Standard: RSS 210 / FCC 15.407 UNII (Radiated)	Class: N/A

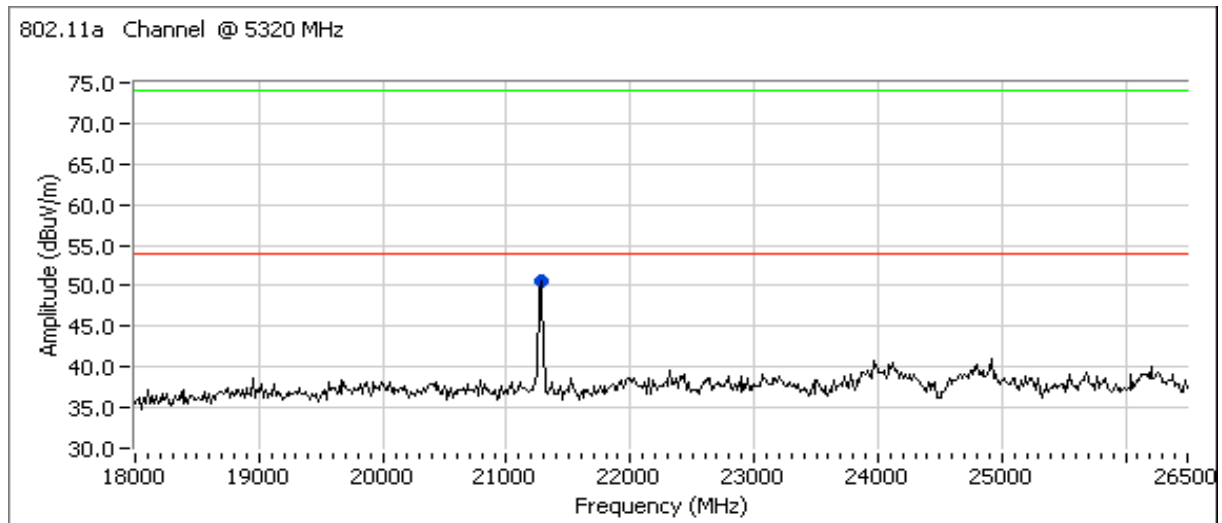
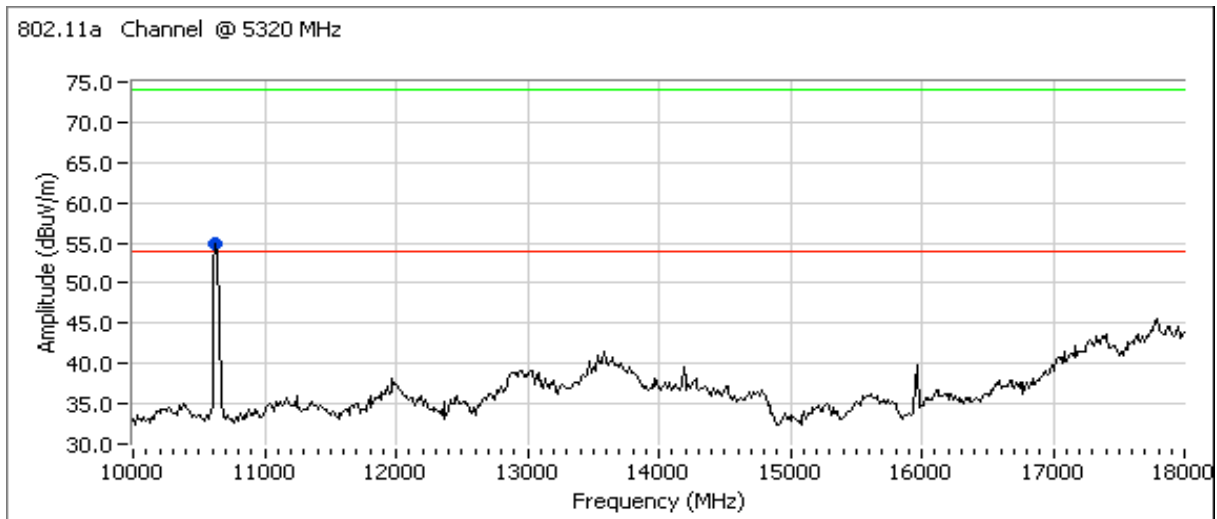

Plot 26 - 40GHz not included ... no emissions observed.

Client: Intel	Job Number: J70979
Model: 512an MMW	T-Log Number: T71043
Contact: Robert Paxman	Account Manager: Briggs / Eriksen
Standard: RSS 210 / FCC 15.407 UNII (Radiated)	Class: N/A

Run #3: Radiated Spurious Emissions, 1000 - 40000 MHz. Operating Mode: 802.11a Chain A

Run #3a: Low Channel @ 5500 MHz

Spurious Emissions

Frequency MHz	Level dB μ V/m	Pol v/h	15.209 / 15.247		Detector Pk/QP/Avg	Azimuth degrees	Height meters	Comments
			Limit	Margin				
3000.390	49.3	V	68.3	-19.0	AVG	274	1.0	Note 2
6000.850	45.1	V	68.3	-23.2	AVG	106	1.0	Note 2
7333.280	46.0	V	54.0	-8.0	AVG	146	1.5	
10999.820	50.6	V	54.0	-3.4	AVG	136	1.3	
21999.950	39.5	V	68.3	-28.8	AVG	173	1.0	Note 2
3000.390	52.7	V	88.3	-35.6	PK	274	1.0	Note 2
6000.850	49.5	V	88.3	-38.8	PK	106	1.0	Note 2
7333.280	50.4	V	74.0	-23.6	PK	146	1.5	
10999.820	62.5	V	74.0	-11.5	PK	136	1.3	
21999.950	50.4	V	74.0	-23.6	PK	173	1.0	

Note 1: For emissions in restricted bands, the limit of 15.209 was used. For all other emissions, the limit was set to -27dBm eirp (68.3dBuV/m average, 88.3dBuV/m peak)

Note 2: Signal is not in a restricted band.

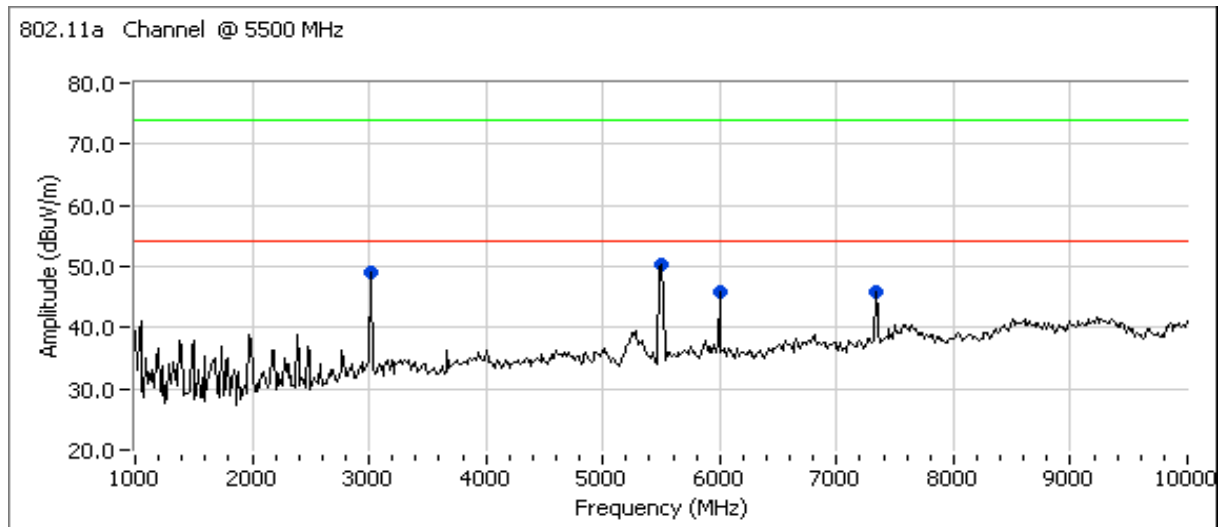

Client: Intel	Job Number: J70979
Model: 512an MMW	T-Log Number: T71043
Contact: Robert Paxman	Account Manager: Briggs / Eriksen
Standard: RSS 210 / FCC 15.407 UNII (Radiated)	Class: N/A

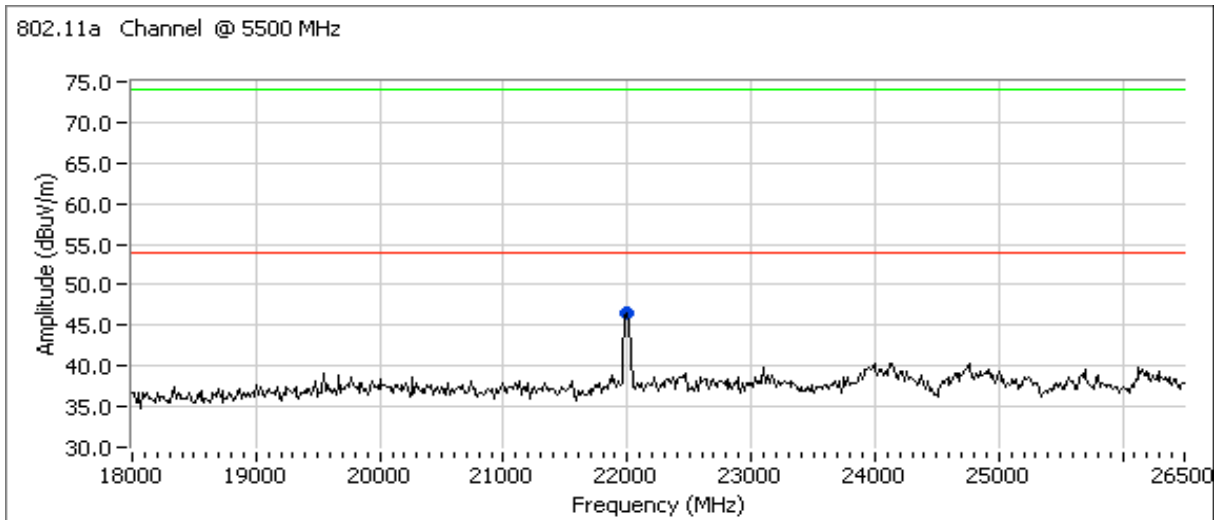
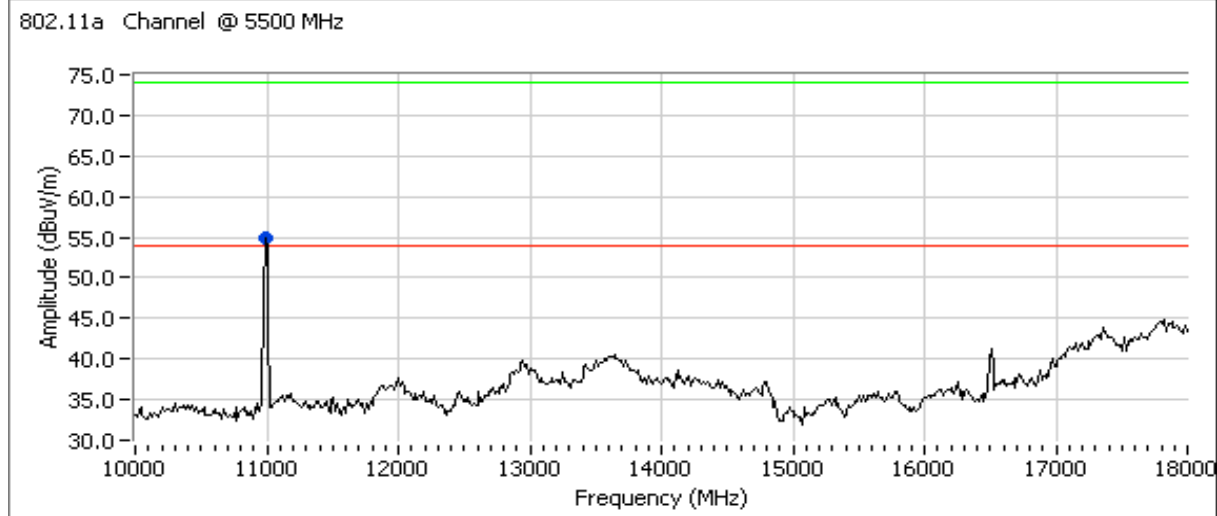

Plot 26 - 40GHz not included ... no emissions observed.

Client: Intel	Job Number: J70979
Model: 512an MMW	T-Log Number: T71043
Contact: Robert Paxman	Account Manager: Briggs / Eriksen
Standard: RSS 210 / FCC 15.407 UNII (Radiated)	Class: N/A

Run #3b: Center Channel @ 5600 MHz

Spurious Emissions

Frequency MHz	Level dB μ V/m	Pol v/h	15.209 / 15.247		Detector Pk/QP/Avg	Azimuth degrees	Height meters	Comments
			Limit	Margin				
3000.300	45.7	V	68.3	-22.6	AVG	260	1.5	Note 2
3000.340	49.9	V	68.3	-18.4	AVG	264	1.5	Note 2
6000.650	47.7	V	68.3	-20.6	AVG	269	1.5	Note 2
11201.960	51.3	V	54.0	-2.7	AVG	64	1.0	
22400.180	37.0	V	54.0	-17.0	AVG	197	1.0	
3000.300	49.7	V	88.3	-38.6	PK	260	1.5	Note 2
3000.340	53.4	V	88.3	-34.9	PK	264	1.5	Note 2
6000.650	51.5	V	88.3	-36.8	PK	269	1.5	Note 2
11201.960	63.5	V	74.0	-10.5	PK	64	1.0	
22400.180	50.1	V	74.0	-23.9	PK	197	1.0	

Note 1: For emissions in restricted bands, the limit of 15.209 was used. For all other emissions, the limit was set to -27dBm eirp (68.3dBuV/m average, 88.3dBuV/m peak)

Note 2: Signal is not in a restricted band.

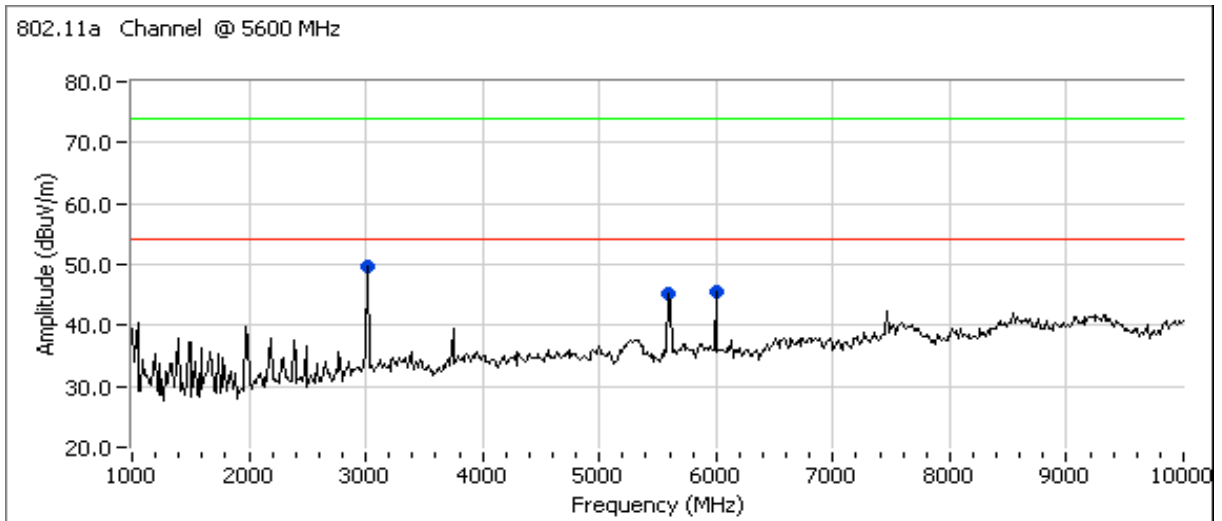

Client:	Intel	Job Number:	J70979
Model:	512an MMW	T-Log Number:	T71043
Contact:	Robert Paxman	Account Manager:	Briggs / Eriksen
Standard:	RSS 210 / FCC 15.407 UNII (Radiated)	Class:	N/A

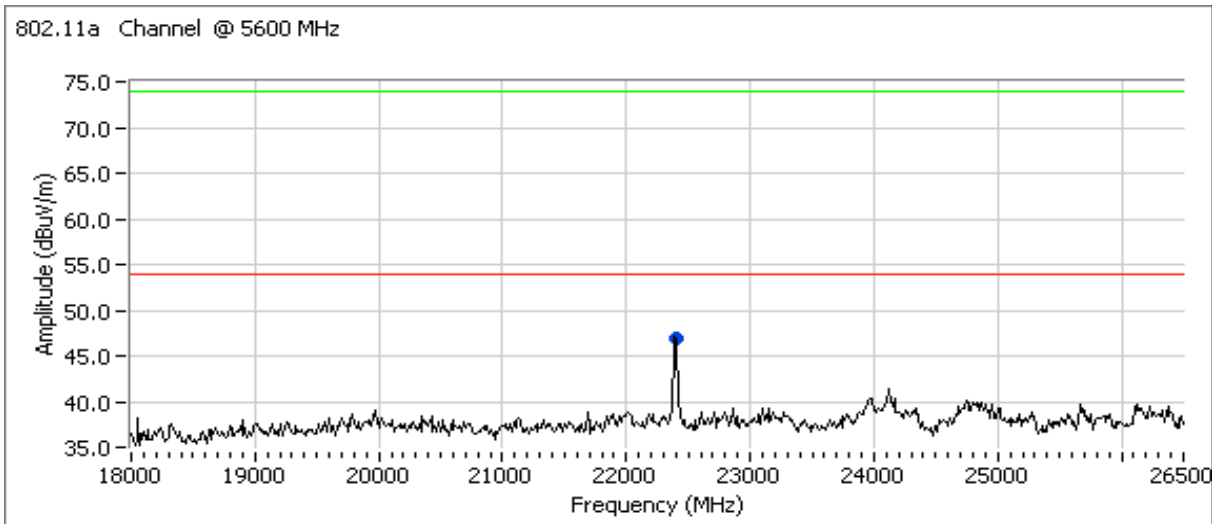
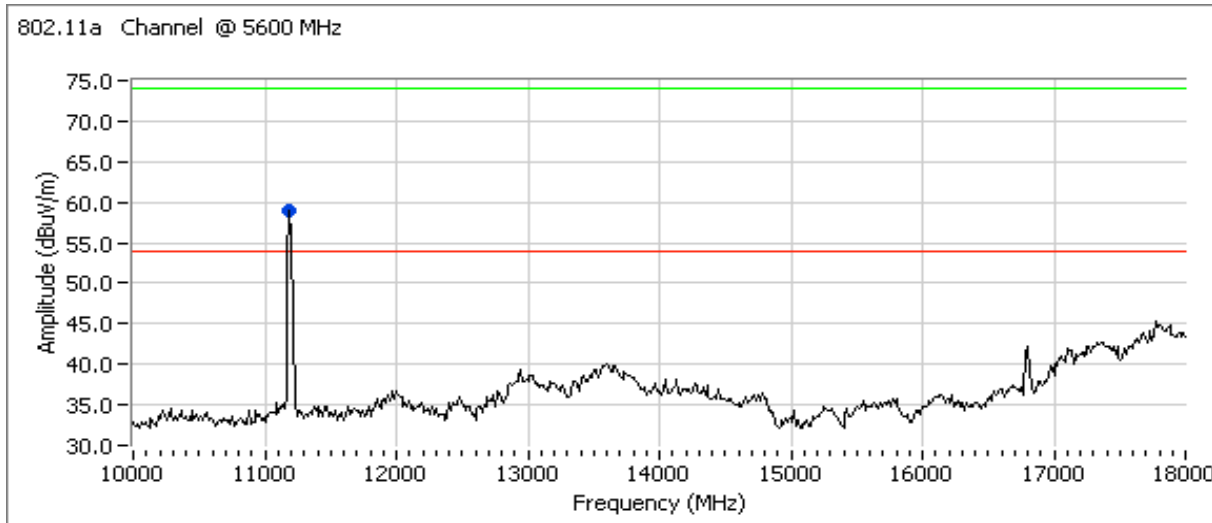

Plot 26 - 40GHz not included ... no emissions observed.

Client:	Intel	Job Number:	J70979
Model:	512an MMW	T-Log Number:	T71043
Contact:	Robert Paxman	Account Manager:	Briggs / Eriksen
Standard:	RSS 210 / FCC 15.407 UNII (Radiated)	Class:	N/A

Run #3c: High Channel @ 5700 MHz
Spurious Emissions

Frequency MHz	Level dB μ V/m	Pol v/h	15.209 / 15.247		Detector Pk/QP/Avg	Azimuth degrees	Height meters	Comments
			Limit	Margin				
3000.330	49.5	V	68.3	-18.8	AVG	275	1.0	Note 2
6000.730	48.1	V	68.3	-20.2	AVG	268	1.5	Note 2
7599.960	45.7	V	54.0	-8.3	AVG	146	2.0	
11399.940	48.3	V	54.0	-5.7	AVG	73	1.0	
22801.570	35.7	V	54.0	-18.3	AVG	106	1.0	
3000.330	53.1	V	88.3	-35.2	PK	275	1.0	Note 2
6000.730	51.5	V	88.3	-36.8	PK	268	1.5	Note 2
7599.960	50.6	V	74.0	-23.4	PK	146	2.0	
11399.940	60.2	V	74.0	-13.8	PK	73	1.0	
22801.570	48.4	V	74.0	-25.6	PK	106	1.0	

Note 1: For emissions in restricted bands, the limit of 15.209 was used. For all other emissions, the limit was set to -27dBm eirp (68.3dBuV/m average, 88.3dBuV/m peak)

Note 2: Signal is not in a restricted band.

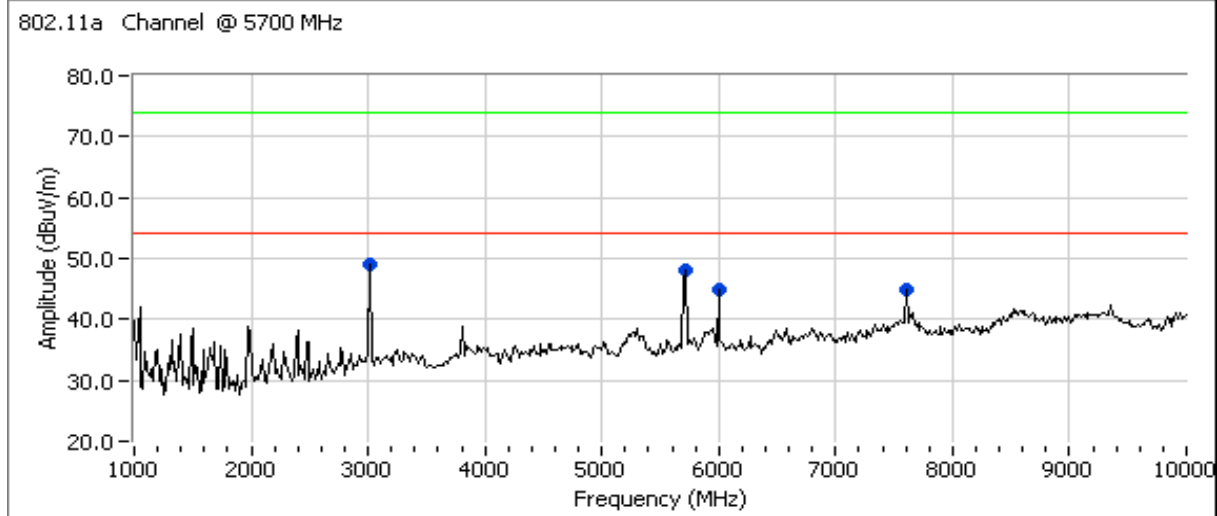

Client: Intel	Job Number: J70979
Model: 512an MMW	T-Log Number: T71043
Contact: Robert Paxman	Account Manager: Briggs / Eriksen
Standard: RSS 210 / FCC 15.407 UNII (Radiated)	Class: N/A

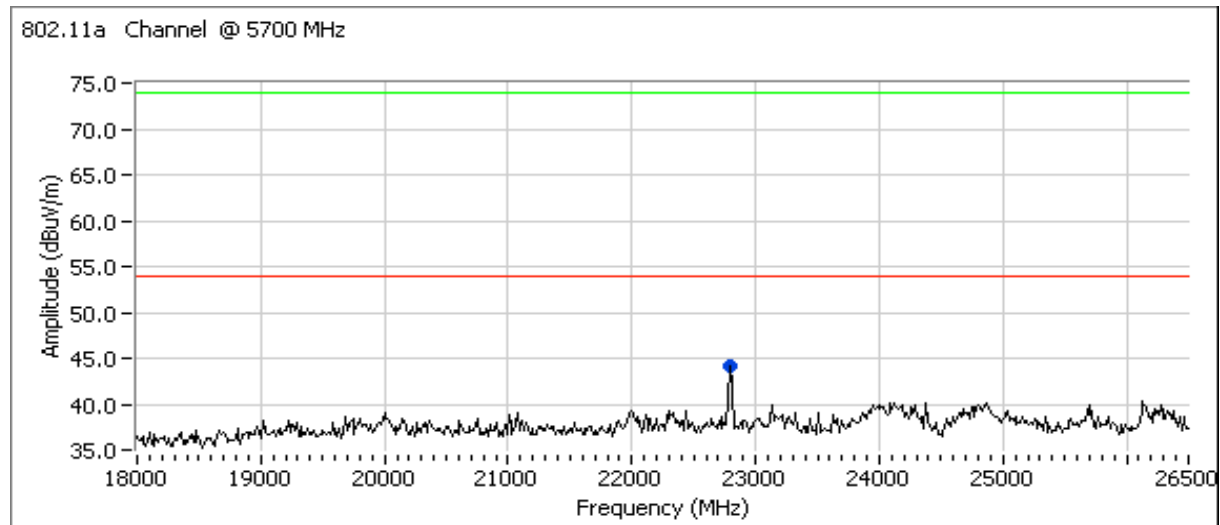
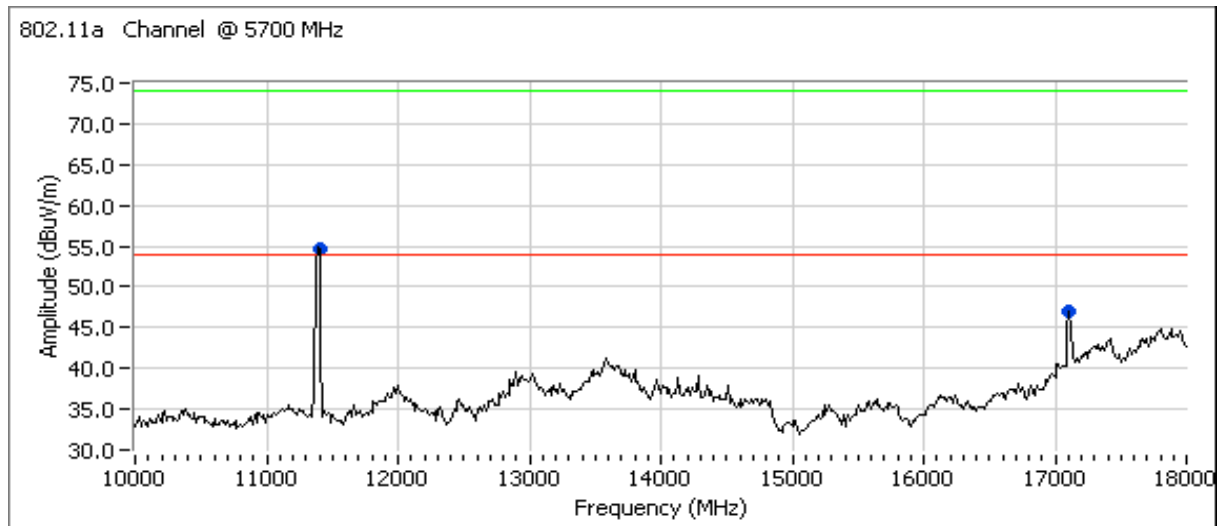

Plot 26 - 40GHz not included ... no emissions observed.

Client:	Intel	Job Number:	J70979
Model:	512an MMW	T-Log Number:	T71043
Contact:	Robert Paxman	Account Manager:	Briggs / Eriksen
Standard:	RSS 210 / FCC 15.407 UNII (Radiated)	Class:	N/A

RSS 210 and FCC 15.E (U-NII, 5150- 550/5250-5350/5460-5725MHz) Radiated Spurious Emissions - Band Edge 802.11n 20MHz Mode

Test Specific Details

Objective: The objective of this test session is to perform final qualification testing of the EUT with respect to the specification listed above.

Date of Test: 3/19/2008
 Test Engineer: Ben Jing
 Test Location: FT Chamber # 4

Config. Used: 1
 Config Change: None
 Host Unit Voltage 120V/60Hz

General Test Configuration

The EUT and all local support equipment were located on the turntable for radiated spurious emissions testing. All remote support equipment was located approximately 30 meters from the EUT with all I/O connections running on top of the groundplane.

For radiated emissions testing the measurement antenna was located 3 meters from the EUT.

Ambient Conditions:
 Temperature: 19 °C
 Rel. Humidity: 44 %

Summary of Results

Run #	Mode	Channel	Power Setting	Measured Power	Test Performed	Limit	Result / Margin
1a	802.11n20 Chain A	5180MHz	GC = 28.5	AP = 18.3	Band Edge radiated field strength	FCC Part 15.209	52.5dBµV/m @ 5149.9MHz (-1.5dB)
1b	802.11n20 Chain A	5320MHz	GC = 25	AP = 16.8	Band Edge radiated field strength	FCC Part 15.209	52.5dBµV/m @ 5350.1MHz (-1.5dB)
1c	802.11n20 Chain A	5500MHz	GC = 29	AP = 18.3	Band Edge radiated field strength	FCC Part 15.209 / 15E	52.8dBµV/m @ 5459.8MHz (-1.2dB)

Modifications Made During Testing

No modifications were made to the EUT during testing

Deviations From The Standard

No deviations were made from the requirements of the standard.

Client: Intel	Job Number: J70979
Model: 512an MMW	T-Log Number: T71043
Contact: Robert Paxman	Account Manager: Briggs / Eriksen
Standard: RSS 210 / FCC 15.407 UNII (Radiated)	Class: N/A

Run #1: Radiated Spurious Emissions, Band Edges. Operating Mode: 802.11n 20MHz - Chain A

Run #1a: Low Channel @ 5180 MHz (band edge at 5150 MHz)

Power Setting: GC = 28.5 Average power: AP = 18.3 (for reference purposes)

Fundamental Signal Field Strength: Peak and average values measured in 1 MHz, for reference only

Frequency	Level	Pol	15.209 / 15.247		Detector	Azimuth	Height	Comments
MHz	dB μ V/m	v/h	Limit	Margin	Pk/QP/Avg	degrees	meters	
5178.710	95.2	V	54.0	41.2	AVG	99	1.0	RB = 1MHz, VB = 10Hz
5178.710	103.3	V	74.0	29.3	PK	99	1.0	RB = VB = 1MHz
5178.820	95.9	H	54.0	41.9	AVG	63	1.0	RB = 1MHz, VB = 10Hz
5178.820	103.9	H	74.0	29.9	PK	63	1.0	RB = VB = 1MHz

Band Edge Signal Field Strength

Frequency	Level	Pol	15.209 / 15.247		Detector	Azimuth	Height	Comments
MHz	dB μ V/m	v/h	Limit	Margin	Pk/QP/Avg	degrees	meters	
5149.890	52.5	H	54.0	-1.5	AVG	63	1.0	GC = 28.5 , AP = 18.3
5149.750	67.9	H	74.0	-6.1	PK	63	1.0	GC = 28.5 , AP = 18.3

Log scale - scaling assumes units are dB units with correction factor applied (36.8 @ 5130.0 MHz)

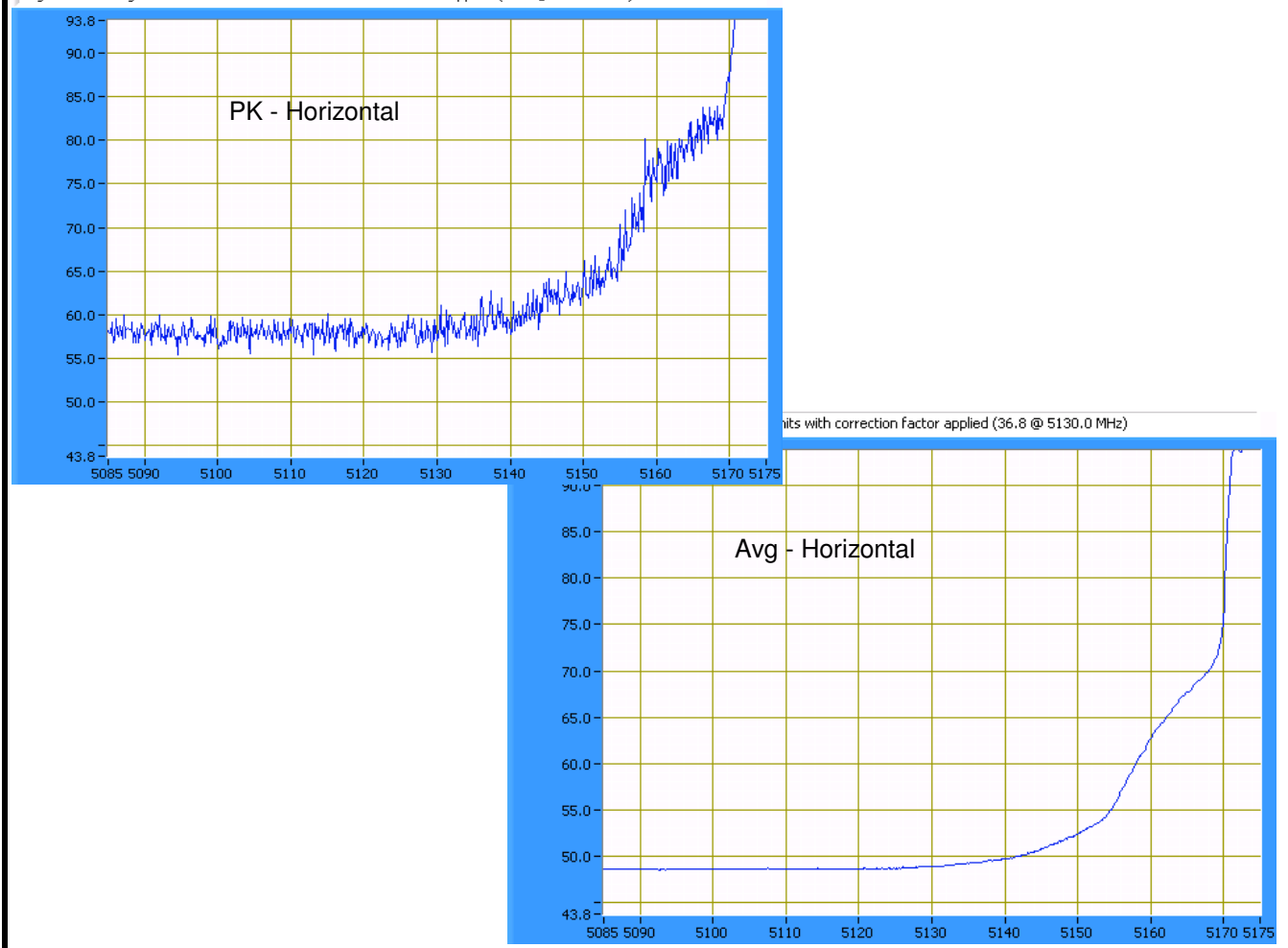

Client: Intel	Job Number: J70979
Model: 512an MMW	T-Log Number: T71043
Contact: Robert Paxman	Account Manager: Briggs / Eriksen
Standard: RSS 210 / FCC 15.407 UNII (Radiated)	Class: N/A

Run #1b: High Channel @ 5320 MHz (band edge at 5350 MHz)

Power Setting: GC = 25 Average power: AP = 16.8 (for reference purposes)

Fundamental Signal Field Strength: Peak and average values measured in 1 MHz, for reference only

Frequency MHz	Level dB μ V/m	Pol v/h	15.209 / 15.247		Detector Pk/QP/Avg	Azimuth degrees	Height meters	Comments
			Limit	Margin				
5320.960	98.3	V	-	-	AVG	150	1.0	
5320.960	106.6	V	-	-	PK	150	1.0	
5318.670	93.4	H	-	-	AVG	297	1.0	
5318.670	101.4	H	-	-	PK	297	1.0	

Band Edge Signal Field Strength

Restricted band starts at allocated band edge (5350MHz), field strength limit is 54dBuV/m average, 74dBuV/m peak.

Frequency MHz	Level dB μ V/m	Pol v/h	15.209 / 15.247		Detector Pk/QP/Avg	Azimuth degrees	Height meters	Comments
			Limit	Margin				
5350.110	52.5	V	54.0	-1.5	AVG	204	1.0	GC = 25 , AP = 16.8
5350.220	69.1	V	74.0	-4.9	PK	203	1.0	GC = 25 , AP = 16.8

Log scale - scaling assumes units are dB units with correction factor applied (37.1 @ 5360.0 MHz)

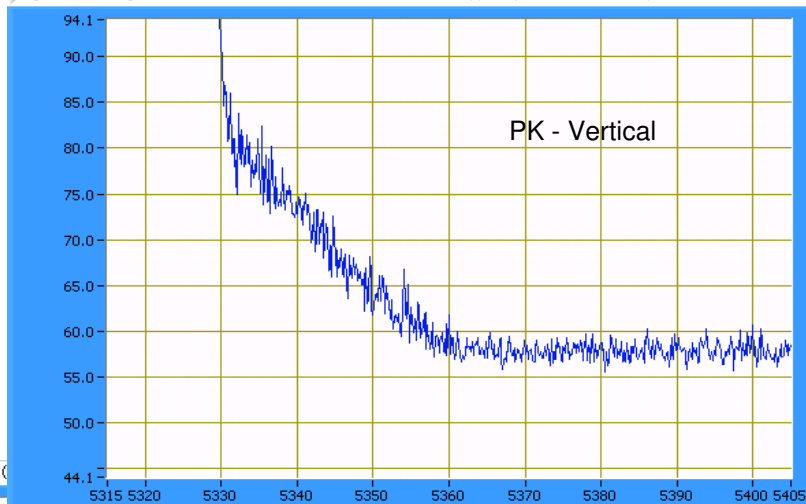

Log scale - scaling assumes units are dB units with correction factor applied (

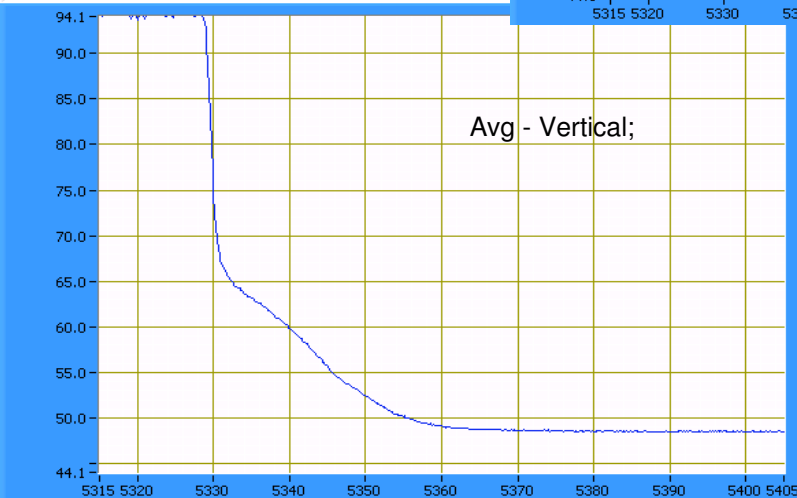

Client: Intel	Job Number: J70979
Model: 512an MMW	T-Log Number: T71043
Contact: Robert Paxman	Account Manager: Briggs / Eriksen
Standard: RSS 210 / FCC 15.407 UNII (Radiated)	Class: N/A

Run #1c: Low Channel @ 5500 MHz (restricted band edge at 5460 MHz, allocated band edge at 5470MHz)

Power Setting: GC = 29 Average power: AP = 18.3 (for reference purposes)

Fundamental Signal Field Strength: Peak and average values measured in 1 MHz, for reference only

Frequency	Level	Pol	15.209 / 15.247		Detector	Azimuth	Height	Comments
MHz	dB μ V/m	v/h	Limit	Margin	Pk/QP/Avg	degrees	meters	
5498.580	100.1	V	-	-	AVG	107	1.0	RB = 1MHz, VB = 10Hz
5498.580	108.3	V	-	-	PK	107	1.0	RB = VB = 1MHz
5498.730	92.4	H	-	-	AVG	297	1.0	RB = 1MHz, VB = 10Hz
5498.730	100.8	H	-	-	PK	297	1.0	RB = VB = 1MHz

5460 Restricted Band Feld strength limit = 54dBuV/m avg, 74dBuV/m peak at 3m

5460 - 5470 MHz, Limit is -27dBm eirp (68.3dBuV/m average, 88.3dBuV/m peak at 3m)

Frequency	Level	Pol	15.209 / 15.247		Detector	Azimuth	Height	Comments
MHz	dB μ V/m	v/h	Limit	Margin	Pk/QP/Avg	degrees	meters	
5459.750	52.8	V	54.0	-1.2	AVG	148	1.0	GC = 29 , AP = 18.3
5459.850	69.4	V	74.0	-4.6	PK	148	1.0	GC = 29 , AP = 18.3

Log scale - scaling assumes units are dB units with correction factor applied (37.2 @ 5450.0 MHz)

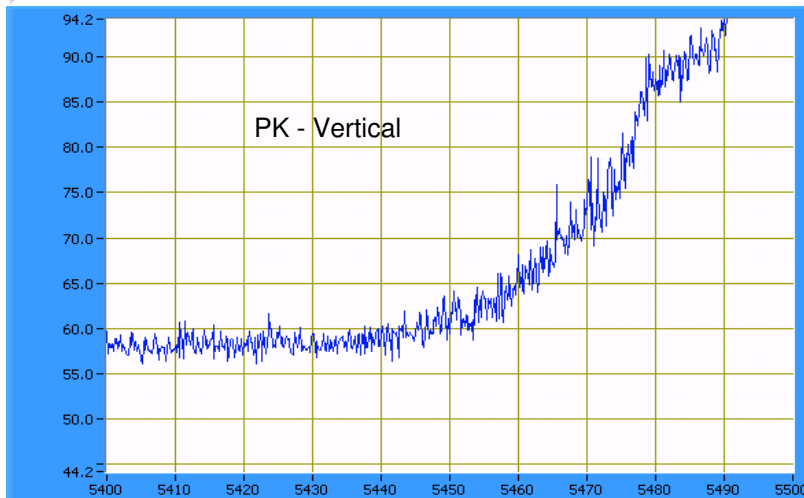

with correction factor applied (37.2 @ 5450.0 MHz)

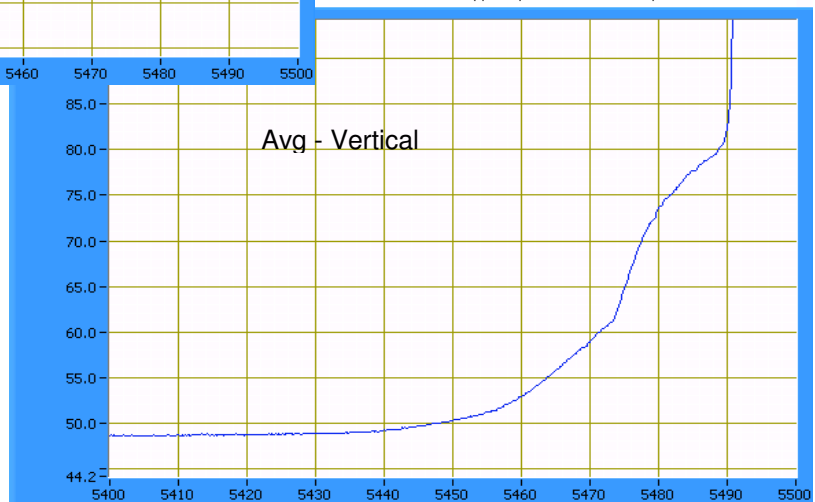

Client:	Intel	Job Number:	J70979
Model:	512an MMW	T-Log Number:	T71043
Contact:	Robert Paxman	Account Manager:	Briggs / Eriksen
Standard:	RSS 210 / FCC 15.407 UNII (Radiated)	Class:	N/A

**RSS 210 and FCC 15.E (U-NII, 5150- 550/5250-5350/5460-5725MHz)
Radiated Spurious Emissions, 1 - 40GHz 802.11n 20MHz Mode**

Test Specific Details

Objective: The objective of this test session is to perform final qualification testing of the EUT with respect to the specification listed above.

Date of Test: 3/24/2008
Test Engineer: Ben Jing
Test Location: Fremont Chamber # 4

Config. Used: 1
Config Change: None
Host Unit Voltage 120V/60Hz

General Test Configuration

The EUT and all local support equipment were located on the turntable for radiated spurious emissions testing. All remote support equipment was located approximately 30 meters from the EUT with all I/O connections running on top of the groundplane.

For radiated emissions testing the measurement antenna was located 3 meters from the EUT.

Ambient Conditions:
Temperature: 19 -21 °C
Rel. Humidity: 34 - 46 %

Modifications Made During Testing

No modifications were made to the EUT during testing

Deviations From The Standard

No deviations were made from the requirements of the standard.

Client:	Intel	Job Number:	J70979
Model:	512an MMW	T-Log Number:	T71043
Contact:	Robert Paxman	Account Manager:	Briggs / Eriksen
Standard:	RSS 210 / FCC 15.407 UNII (Radiated)	Class:	N/A

Summary of Results

Run #	Mode	Channel	Power Setting	Measured Power	Test Performed	Limit	Result / Margin
1a	802.11n20 Chain A	5180	27.0	16.5	Radiated Emissions, 1 - 40 GHz	FCC Part 15.209 / 15.407	50.4dBµV/m @ 3000.4MHz (-17.9dB)
1b	802.11n20 Chain A	5200	26.5	16.5	Radiated Emissions, 1 - 40 GHz	FCC Part 15.209 / 15.407	49.6dBµV/m @ 3000.4MHz (-18.7dB)
1c	802.11n20 Chain A	5240	25.5	16.5	Radiated Emissions, 1 - 40 GHz	FCC Part 15.209 / 15.407	49.7dBµV/m @ 3000.4MHz (-18.6dB)
2a	802.11n20 Chain A	5260	25.5	16.7	Radiated Emissions, 1 - 40 GHz	FCC Part 15.209 / 15.407	50.3dBµV/m @ 3000.4MHz (-18.0dB)
2b	802.11n20 Chain A	5280	24.5	16.5	Radiated Emissions, 1 - 40 GHz	FCC Part 15.209 / 15.407	50.4dBµV/m @ 3000.4MHz (-17.9dB)
2c	802.11n20 Chain A	5320	24.0	16.5	Radiated Emissions, 1 - 40 GHz	FCC Part 15.209 / 15.407	44.6dBµV/m @ 10637.2MHz (-9.4dB)
3a	802.11n20 Chain A	5500	25.0	16.6	Radiated Emissions, 1 - 40 GHz	FCC Part 15.209 / 15.407	43.8dBµV/m @ 10999.2MHz (-10.2dB)
3b	802.11n20 Chain A	5600	25.5	16.5	Radiated Emissions, 1 - 40 GHz	FCC Part 15.209 / 15.407	49.8dBµV/m @ 11200.1MHz (-4.2dB)
3c	802.11n20 Chain A	5700	28.0	16.6	Radiated Emissions, 1 - 40 GHz	FCC Part 15.209 / 15.407	45.4dBµV/m @ 7599.9MHz (-8.6dB)

Run #1: Radiated Spurious Emissions, 1000 - 40000 MHz. Operating Mode: 802.11n 20MHz Chain A

Run #1a: Low Channel @ 5180 MHz

Spurious Emissions

Frequency	Level	Pol	15.209 / 15.247		Detector	Azimuth	Height	Comments
MHz	dBµV/m	v/h	Limit	Margin	Pk/QP/Avg	degrees	meters	
3000.380	50.4	V	68.3	-17.9	AVG	270	1.0	Note 2
6000.770	47.1	V	68.3	-21.2	AVG	273	1.5	Note 2
6906.650	45.3	V	68.3	-23.0	AVG	81	1.0	Note 2
10360.210	43.8	V	68.3	-24.5	AVG	241	1.0	Note 2
3000.380	53.4	V	88.3	-34.9	PK	270	1.0	Note 2
6000.770	50.9	V	88.3	-37.4	PK	273	1.5	Note 2
6906.650	49.6	V	88.3	-38.7	PK	81	1.0	Note 2
10360.210	56.8	V	88.3	-31.5	PK	241	1.0	Note 2

Note 1: For emissions in restricted bands, the limit of 15.209 was used. For all other emissions, the limit was set to -27dBm eirp (68.3dBuV/m average, 88.3dBuV/m peak)

Note 2: Signal is not in a restricted band.

Client: Intel	Job Number: J70979
Model: 512an MMW	T-Log Number: T71043
Contact: Robert Paxman	Account Manager: Briggs / Eriksen
Standard: RSS 210 / FCC 15.407 UNII (Radiated)	Class: N/A

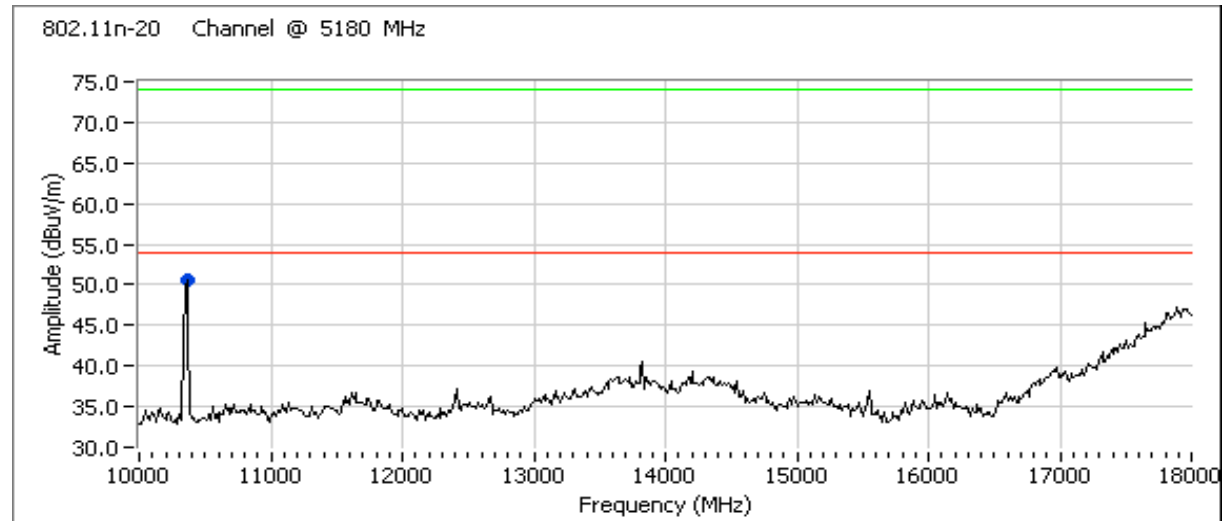
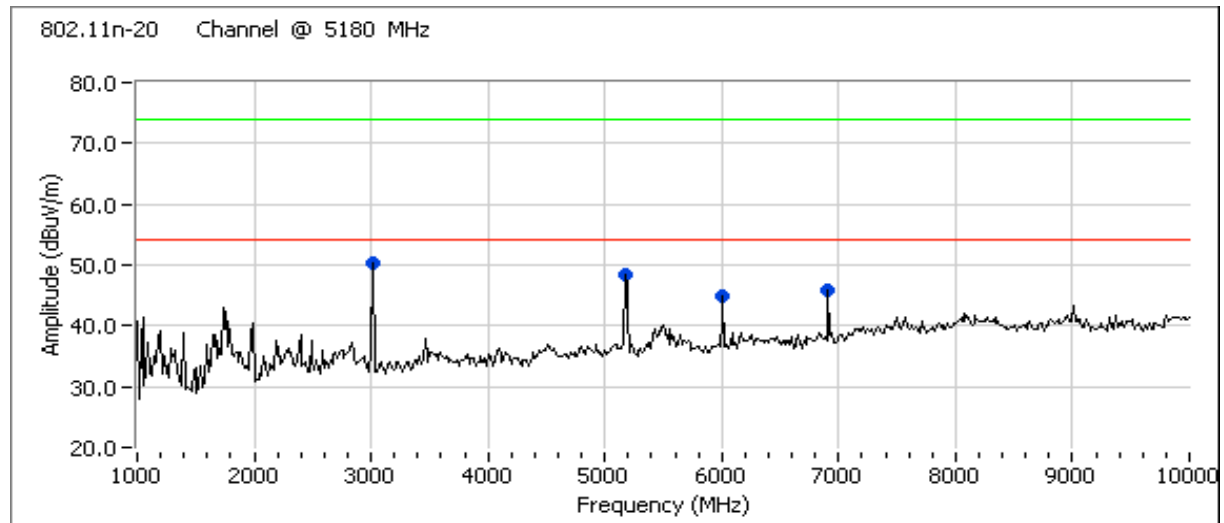

Client: Intel	Job Number: J70979
Model: 512an MMW	T-Log Number: T71043
Contact: Robert Paxman	Account Manager: Briggs / Eriksen
Standard: RSS 210 / FCC 15.407 UNII (Radiated)	Class: N/A

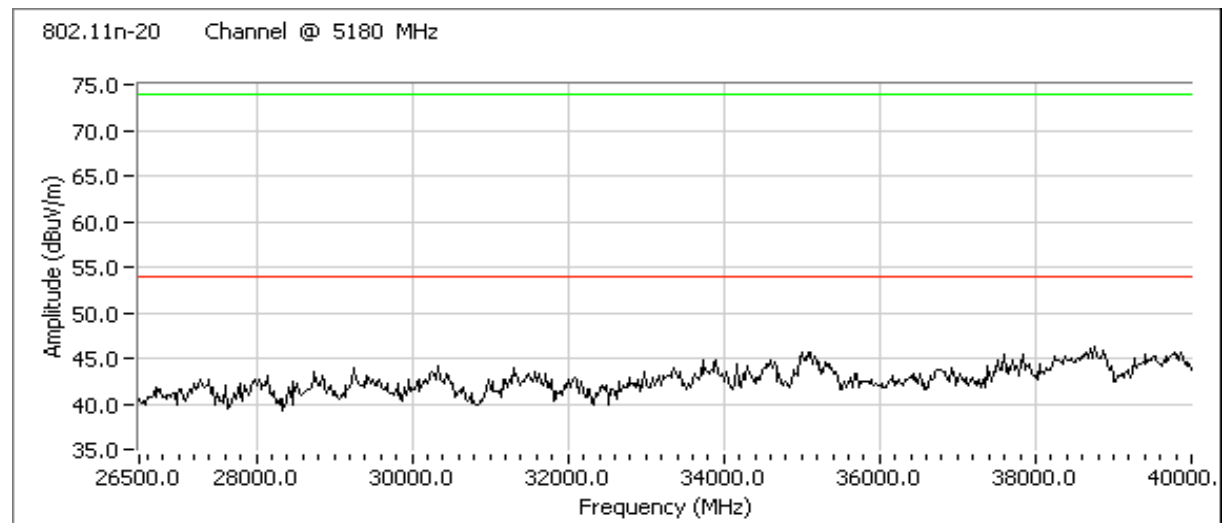
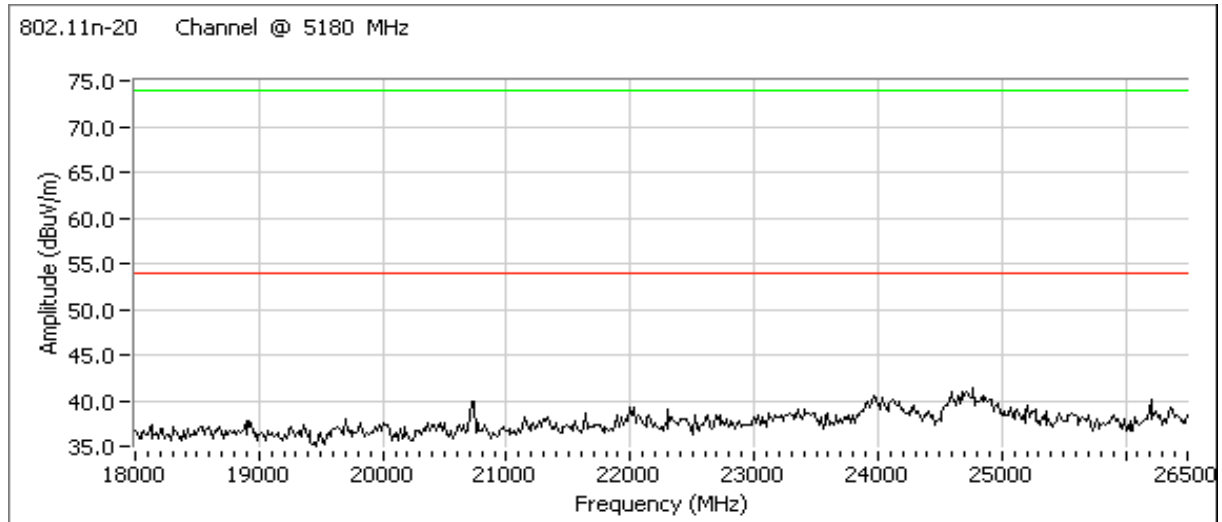

Client:	Intel	Job Number:	J70979
Model:	512an MMW	T-Log Number:	T71043
Contact:	Robert Paxman	Account Manager:	Briggs / Eriksen
Standard:	RSS 210 / FCC 15.407 UNII (Radiated)	Class:	N/A

Run #1b: Center Channel @ 5200 MHz
Spurious Emissions

Frequency MHz	Level dB μ V/m	Pol v/h	15.209 / 15.247		Detector Pk/QP/Avg	Azimuth degrees	Height meters	Comments
			Limit	Margin				
3000.380	49.6	V	68.3	-18.7	AVG	283	1.0	Note 2
6000.810	47.3	V	68.3	-21.0	AVG	272	1.5	Note 2
6933.280	46.0	V	68.3	-22.3	AVG	212	1.5	Note 2
10400.160	43.9	V	68.3	-24.4	AVG	72	1.0	Note 2
3000.380	53.0	V	88.3	-35.3	PK	283	1.0	Note 2
6000.810	51.0	V	88.3	-37.3	PK	272	1.5	Note 2
6933.280	50.1	V	88.3	-38.2	PK	212	1.5	Note 2
10400.160	56.9	V	88.3	-31.4	PK	72	1.0	Note 2

Note 1: For emissions in restricted bands, the limit of 15.209 was used. For all other emissions, the limit was set to -27dBm eirp (68.3dB μ V/m average, 88.3dB μ V/m peak)

Note 2: Signal is not in a restricted band.

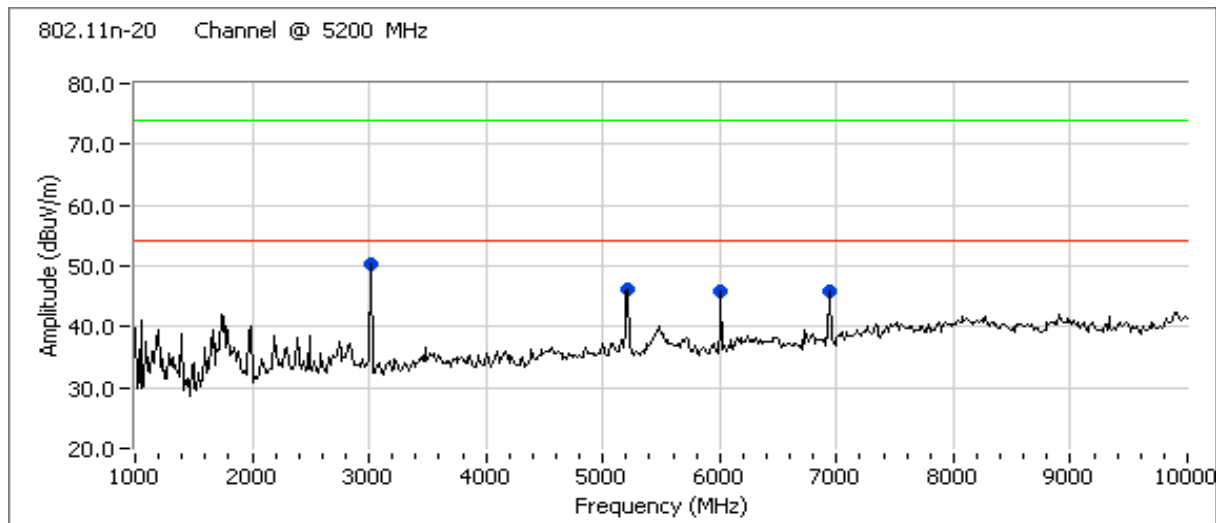

Client:	Intel	Job Number:	J70979
Model:	512an MMW	T-Log Number:	T71043
Contact:	Robert Paxman	Account Manager:	Briggs / Eriksen
Standard:	RSS 210 / FCC 15.407 UNII (Radiated)	Class:	N/A

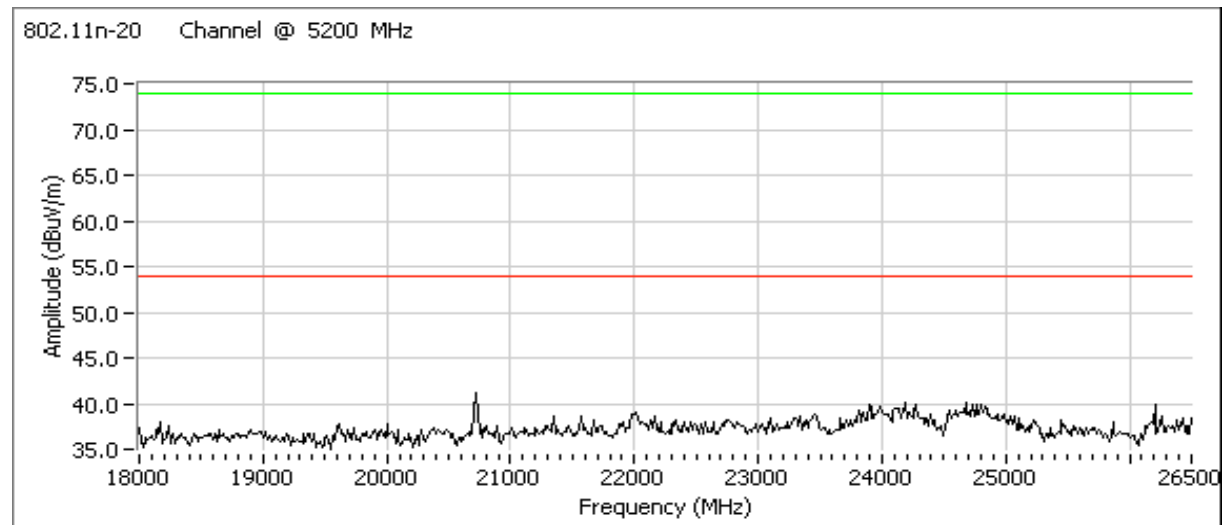
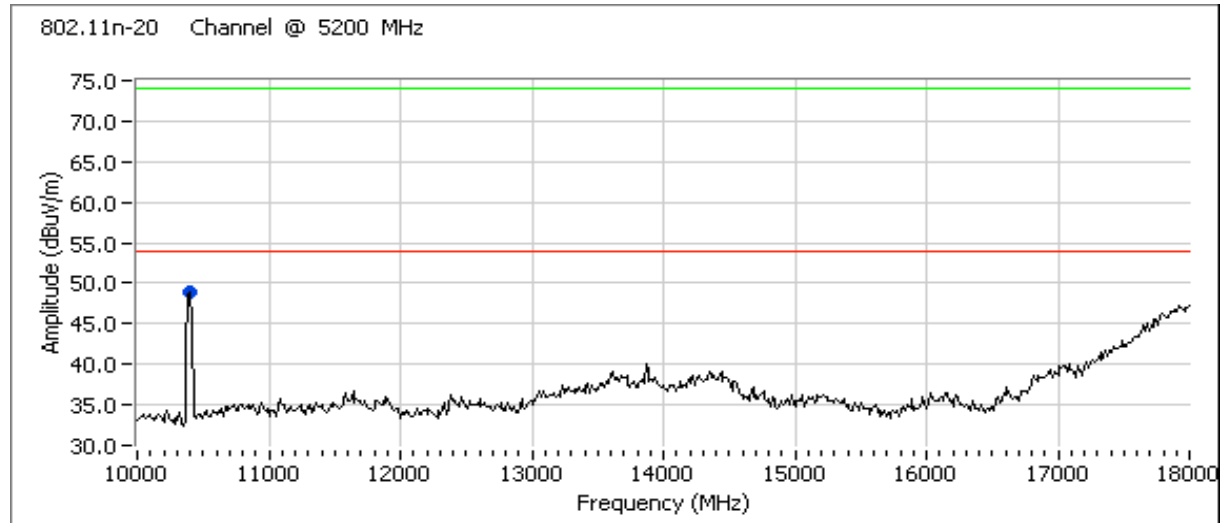

Client: Intel	Job Number: J70979
Model: 512an MMW	T-Log Number: T71043
Contact: Robert Paxman	Account Manager: Briggs / Eriksen
Standard: RSS 210 / FCC 15.407 UNII (Radiated)	Class: N/A

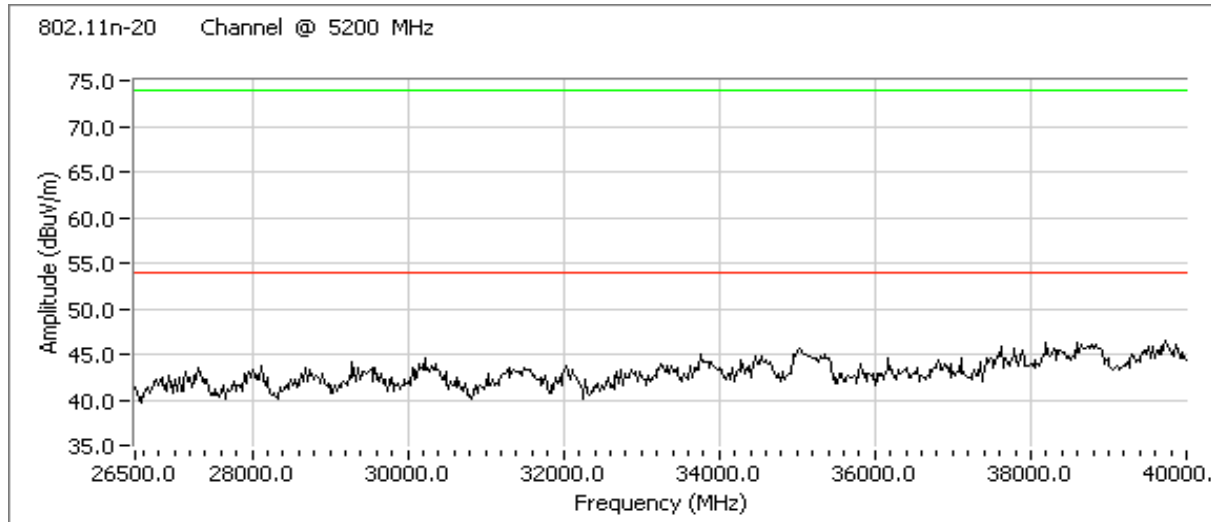

Run #1c: High Channel @ 5240 MHz
Spurious Emissions

Frequency	Level	Pol	15.209 / 15.247		Detector	Azimuth	Height	Comments
MHz	dBuV/m	v/h	Limit	Margin	Pk/QP/Avg	degrees	meters	
3000.390	49.7	V	68.3	-18.6	AVG	280	1.0	Note 2
6000.790	44.0	V	68.3	-24.3	AVG	164	1.0	Note 2
6986.650	49.4	V	68.3	-18.9	AVG	76	1.0	Note 2
10480.080	45.1	V	68.3	-23.2	AVG	130	1.3	Note 2
3000.390	52.9	V	88.3	-35.4	PK	280	1.0	Note 2
6000.790	48.8	V	88.3	-39.5	PK	164	1.0	Note 2
6986.650	52.1	V	88.3	-36.2	PK	76	1.0	Note 2
10480.080	58.3	V	88.3	-30.0	PK	130	1.3	Note 2

Note 1: For emissions in restricted bands, the limit of 15.209 was used. For all other emissions, the limit was set to -27dBm eirp (68.3dBuV/m average, 88.3dBuV/m peak)

Note 2: Signal is not in a restricted band.

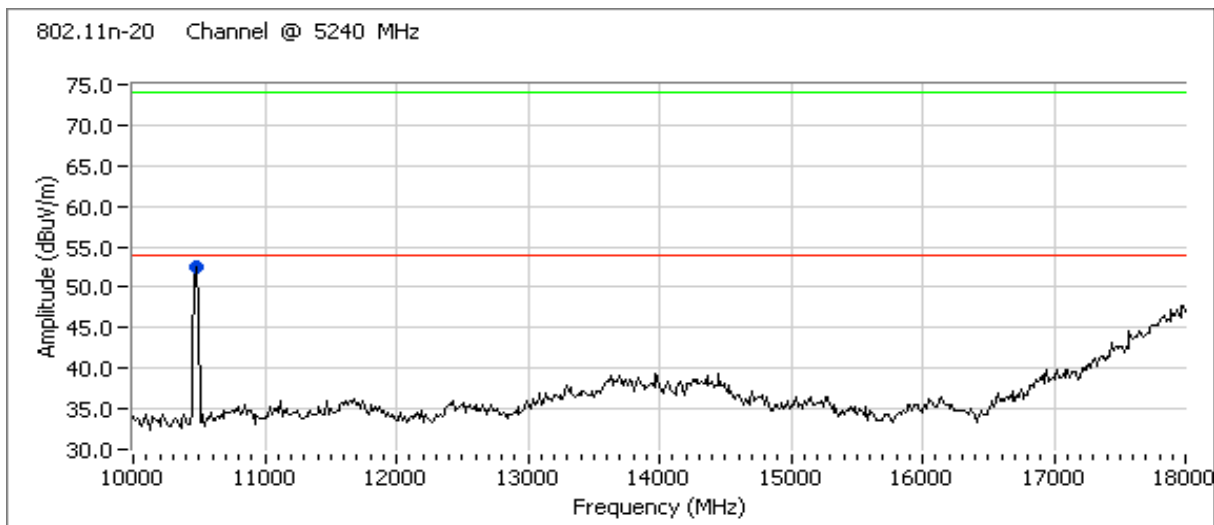
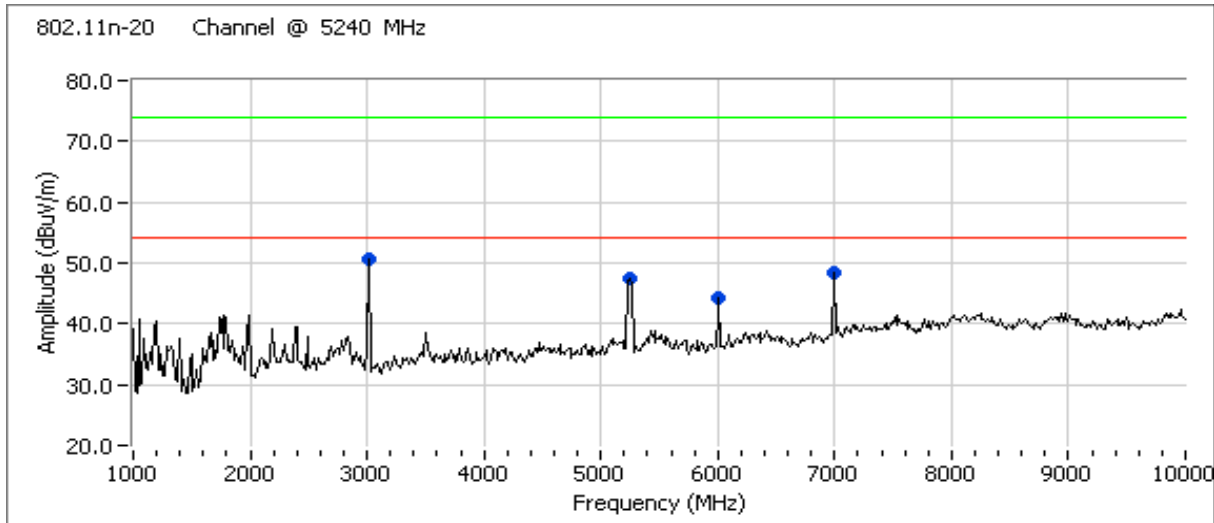
Client: Intel	Job Number: J70979
Model: 512an MMW	T-Log Number: T71043
Contact: Robert Paxman	Account Manager: Briggs / Eriksen
Standard: RSS 210 / FCC 15.407 UNII (Radiated)	Class: N/A



Client: Intel	Job Number: J70979
Model: 512an MMW	T-Log Number: T71043
Contact: Robert Paxman	Account Manager: Briggs / Eriksen
Standard: RSS 210 / FCC 15.407 UNII (Radiated)	Class: N/A

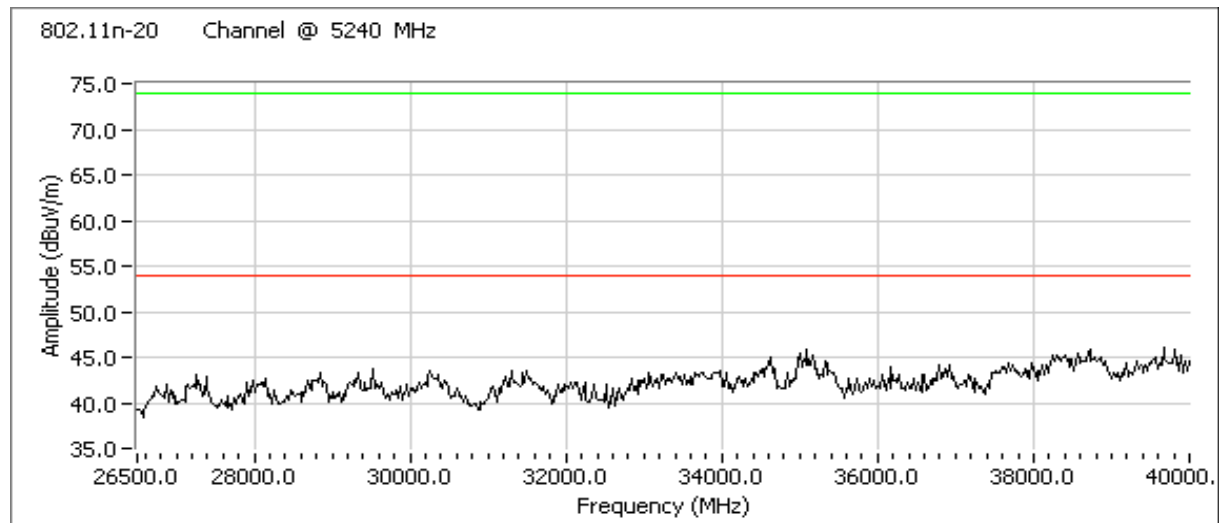
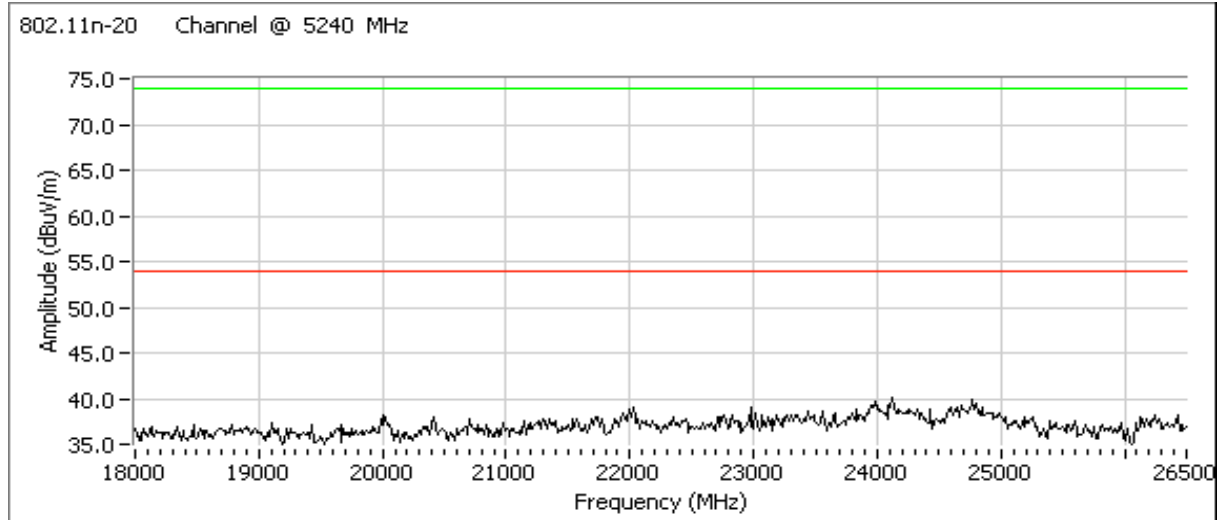

Client: Intel	Job Number: J70979
Model: 512an MMW	T-Log Number: T71043
Contact: Robert Paxman	Account Manager: Briggs / Eriksen
Standard: RSS 210 / FCC 15.407 UNII (Radiated)	Class: N/A

Run #2: Radiated Spurious Emissions, 1000 - 40000 MHz. Operating Mode: 802.11n20 Chain A
Run #2a: Low Channel @ 5260 MHz
Spurious Emissions

Frequency MHz	Level dB μ V/m	Pol v/h	15.209 / 15.247		Detector Pk/QP/Avg	Azimuth degrees	Height meters	Comments
			Limit	Margin				
3000.410	50.3	V	68.3	-18.0	AVG	271	1.0	Note 2
6000.780	46.4	V	68.3	-21.9	AVG	275	1.5	Note 2
7013.310	48.8	V	68.3	-19.5	AVG	76	1.5	Note 2
10518.950	48.8	V	68.3	-19.5	AVG	212	1.0	Note 2
3000.410	53.7	V	88.3	-34.6	PK	271	1.0	Note 2
6000.780	50.4	V	88.3	-37.9	PK	275	1.5	Note 2
7013.310	52.2	V	88.3	-36.1	PK	76	1.5	Note 2
10518.950	62.1	V	88.3	-26.2	PK	212	1.0	Note 2

Note 1: For emissions in restricted bands, the limit of 15.209 was used. For all other emissions, the limit was set to -27dBm eirp (68.3dBuV/m average, 88.3dBuV/m peak)

Note 2: Signal is not in a restricted band.

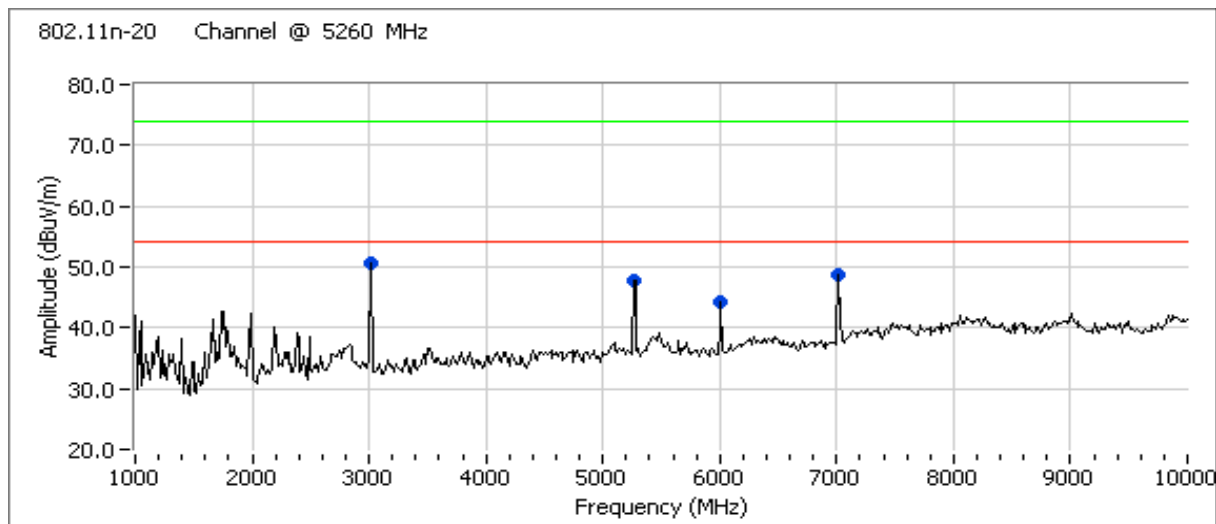

Client: Intel	Job Number: J70979
Model: 512an MMW	T-Log Number: T71043
Contact: Robert Paxman	Account Manager: Briggs / Eriksen
Standard: RSS 210 / FCC 15.407 UNII (Radiated)	Class: N/A

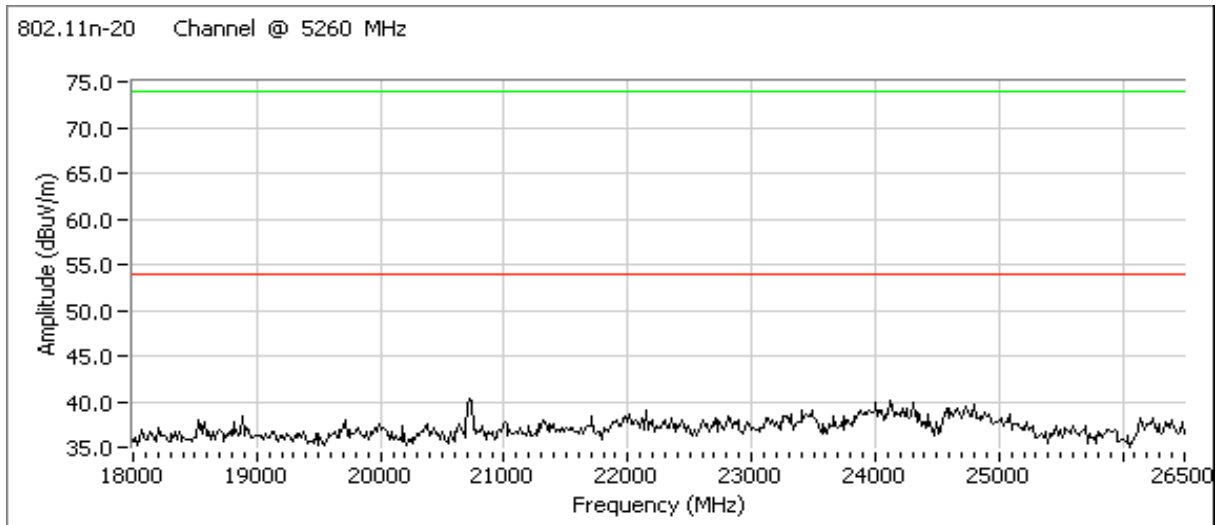
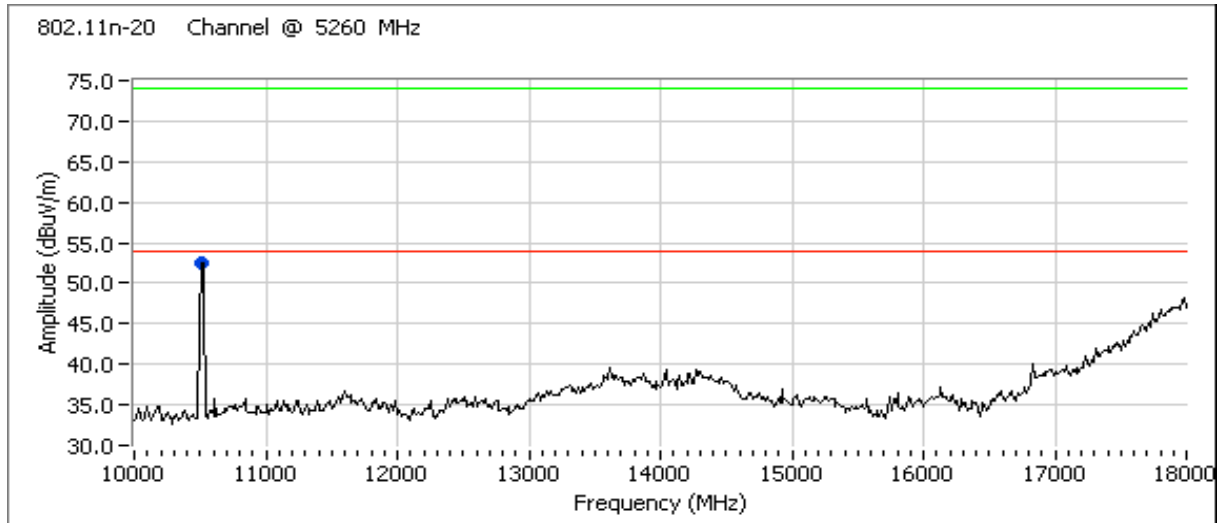

Client:	Intel	Job Number:	J70979
Model:	512an MMW	T-Log Number:	T71043
Contact:	Robert Paxman	Account Manager:	Briggs / Eriksen
Standard:	RSS 210 / FCC 15.407 UNII (Radiated)	Class:	N/A

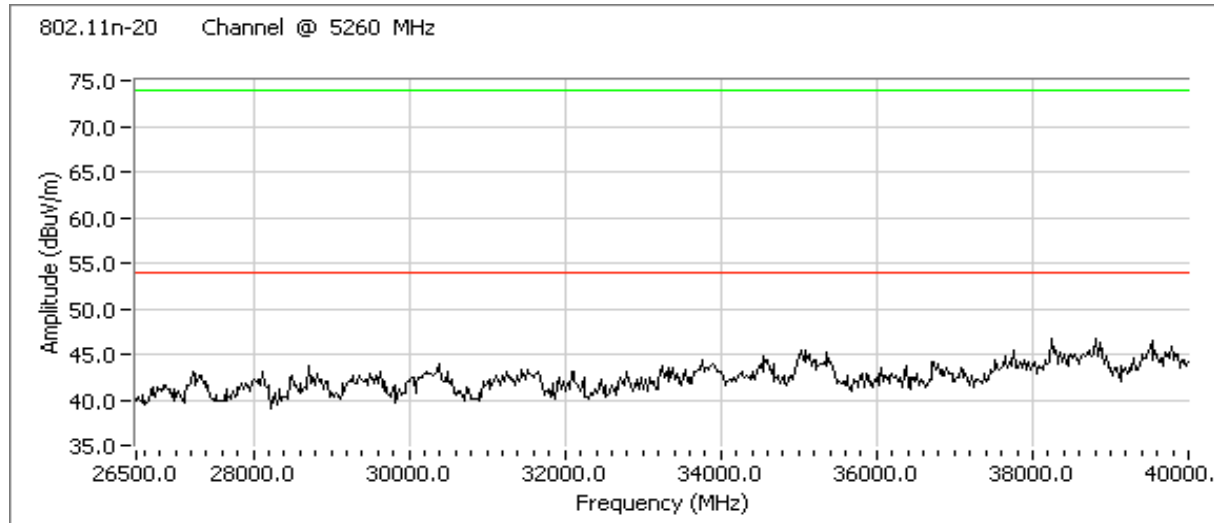

Run #2b: Center Channel @ 5280 MHz
Spurious Emissions

Frequency	Level	Pol	15.209 / 15.247		Detector	Azimuth	Height	Comments
MHz	dBuV/m	v/h	Limit	Margin	PK/QP/Avg	degrees	meters	
3000.370	50.4	V	68.3	-17.9	AVG	270	1.0	Note 2
6000.730	44.4	V	68.3	-23.9	AVG	166	1.0	Note 2
7040.000	43.5	V	68.3	-24.8	AVG	89	1.0	Note 2
10560.640	47.8	V	68.3	-20.5	AVG	210	1.0	Note 2
3000.370	53.9	V	88.3	-34.4	PK	270	1.0	Note 2
6000.730	49.9	V	88.3	-38.4	PK	166	1.0	Note 2
7040.000	48.6	V	88.3	-39.7	PK	89	1.0	Note 2
10560.640	60.5	V	88.3	-27.8	PK	210	1.0	Note 2

Note 1: For emissions in restricted bands, the limit of 15.209 was used. For all other emissions, the limit was set to -27dBm eirp (68.3dBuV/m average, 88.3dBuV/m peak)

Note 2: Signal is not in a restricted band.

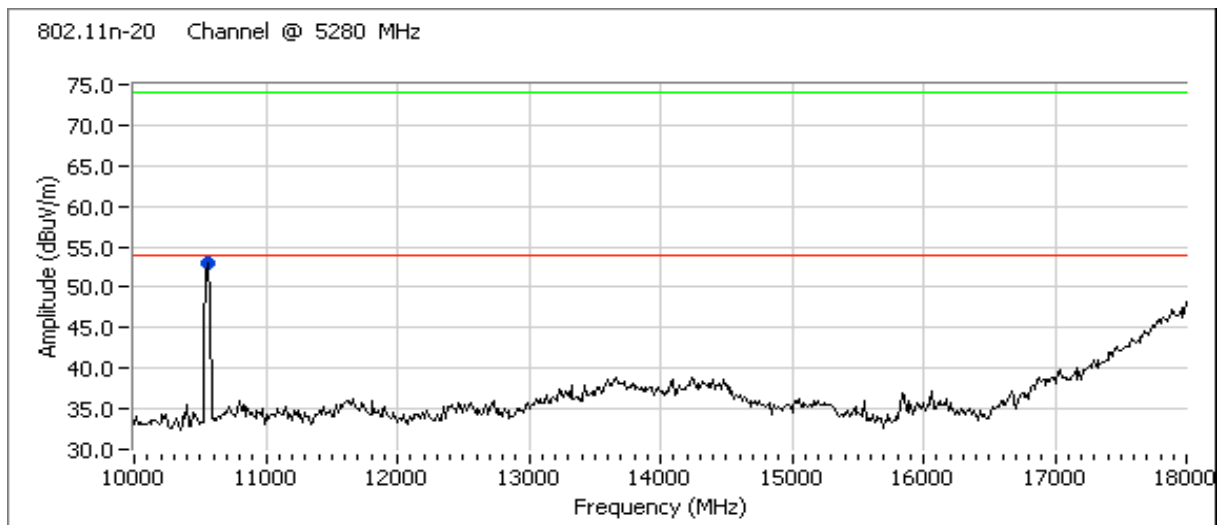
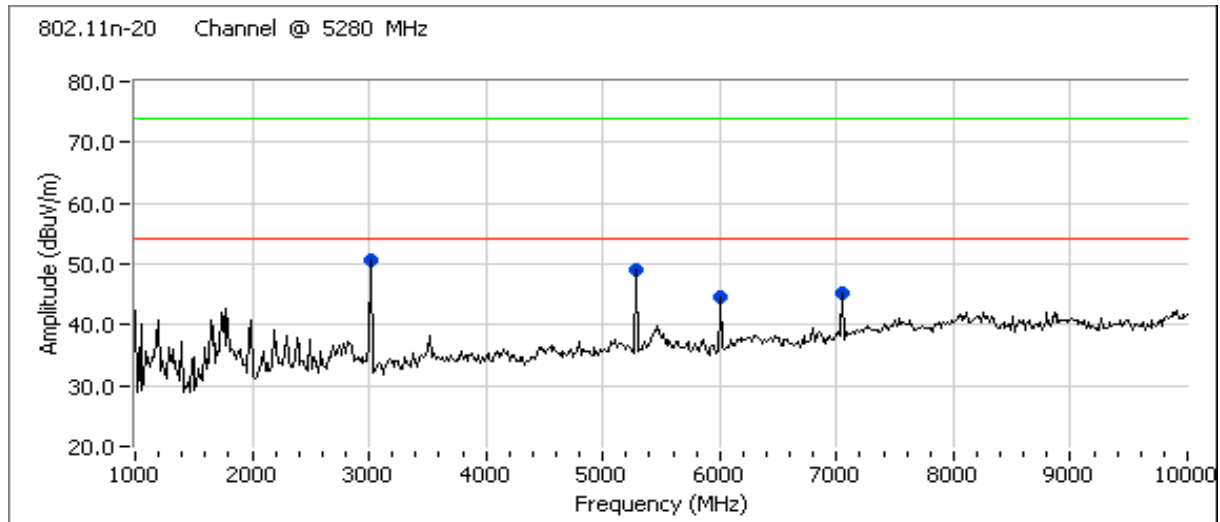
Client: Intel	Job Number: J70979
Model: 512an MMW	T-Log Number: T71043
Contact: Robert Paxman	Account Manager: Briggs / Eriksen
Standard: RSS 210 / FCC 15.407 UNII (Radiated)	Class: N/A



Client: Intel	Job Number: J70979
Model: 512an MMW	T-Log Number: T71043
Contact: Robert Paxman	Account Manager: Briggs / Eriksen
Standard: RSS 210 / FCC 15.407 UNII (Radiated)	Class: N/A

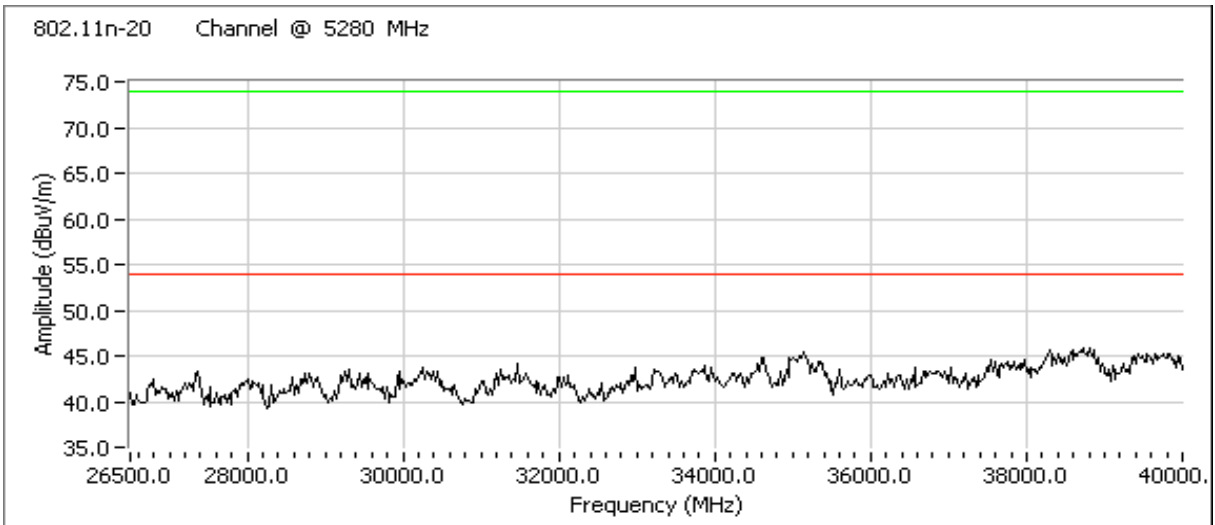
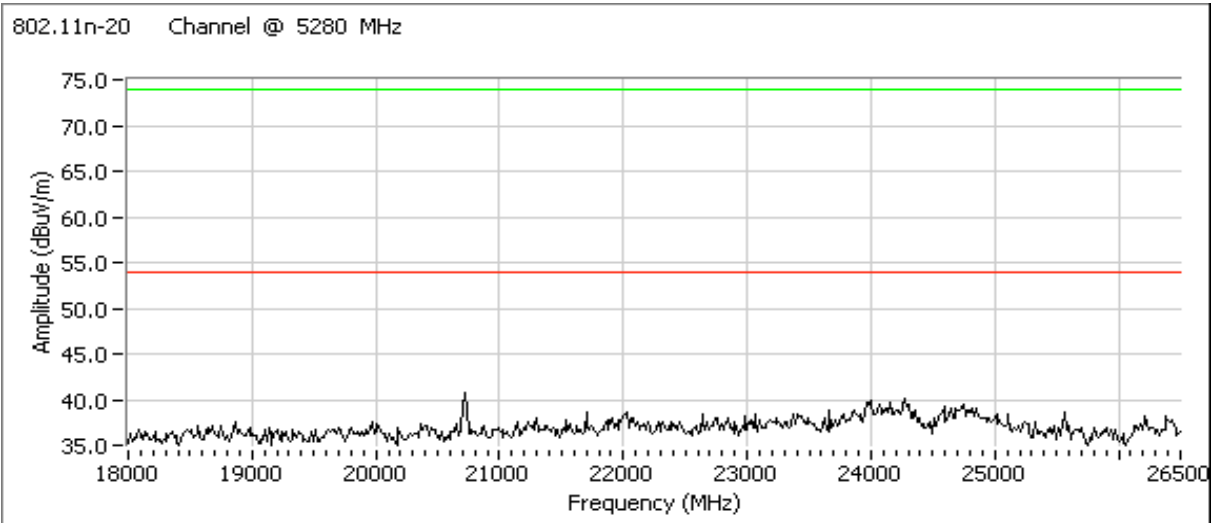

Client: Intel	Job Number: J70979
Model: 512an MMW	T-Log Number: T71043
Contact: Robert Paxman	Account Manager: Briggs / Eriksen
Standard: RSS 210 / FCC 15.407 UNII (Radiated)	Class: N/A

Run #2c: High Channel @ 5320 MHz
Spurious Emissions

Frequency MHz	Level dB μ V/m	Pol v/h	15.209 / 15.247		Detector Pk/QP/Avg	Azimuth degrees	Height meters	Comments
			Limit	Margin				
3000.420	48.6	V	68.3	-19.7	AVG	277	1.0	Note 2
6000.830	45.7	V	68.3	-22.6	AVG	274	1.0	Note 2
7093.330	43.2	V	68.3	-25.1	AVG	226	1.5	Note 2
10637.230	44.6	V	54.0	-9.4	AVG	183	1.0	
3000.420	52.0	V	88.3	-36.3	PK	277	1.0	Note 2
6000.830	50.1	V	88.3	-38.2	PK	274	1.0	Note 2
7093.330	48.7	V	88.3	-39.6	PK	226	1.5	Note 2
10637.230	57.8	V	74.0	-16.2	PK	183	1.0	

Note 1: For emissions in restricted bands, the limit of 15.209 was used. For all other emissions, the limit was set to -27dBm eirp (68.3dB μ V/m average, 88.3dB μ V/m peak)

Note 2: Signal is not in a restricted band.

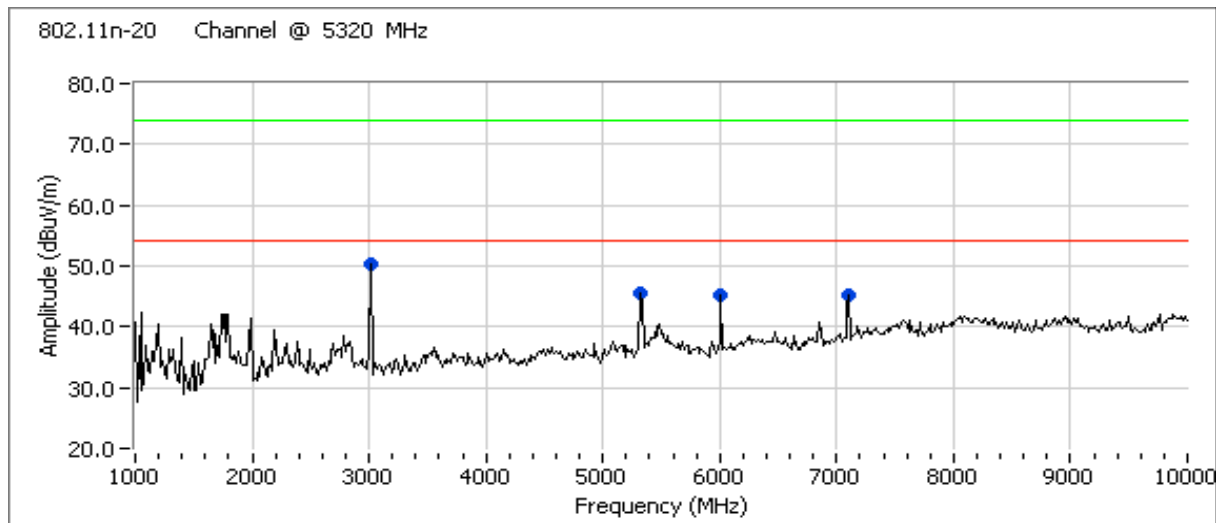

Client: Intel	Job Number: J70979
Model: 512an MMW	T-Log Number: T71043
Contact: Robert Paxman	Account Manager: Briggs / Eriksen
Standard: RSS 210 / FCC 15.407 UNII (Radiated)	Class: N/A

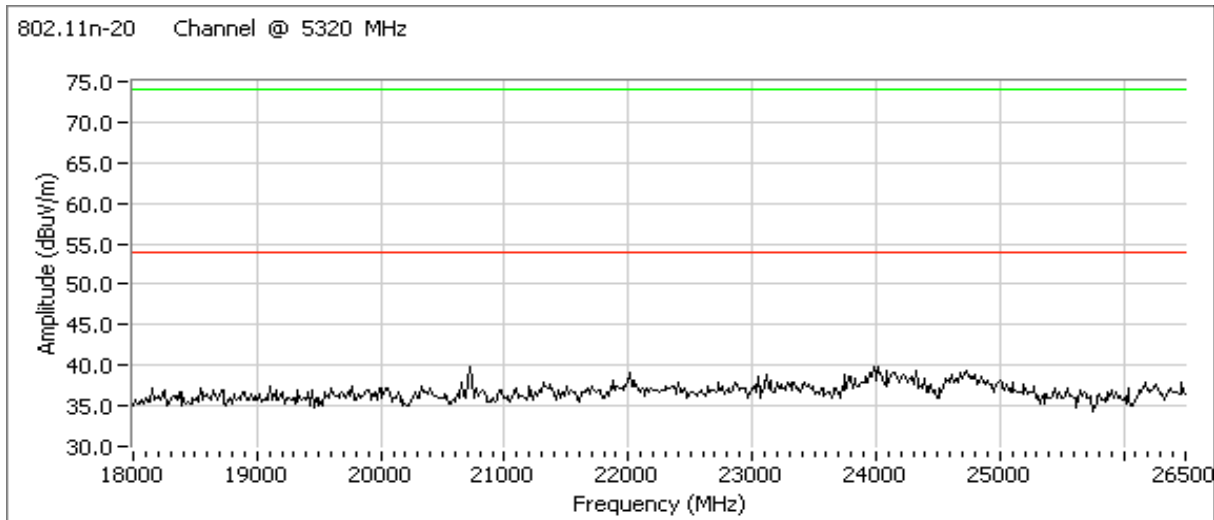
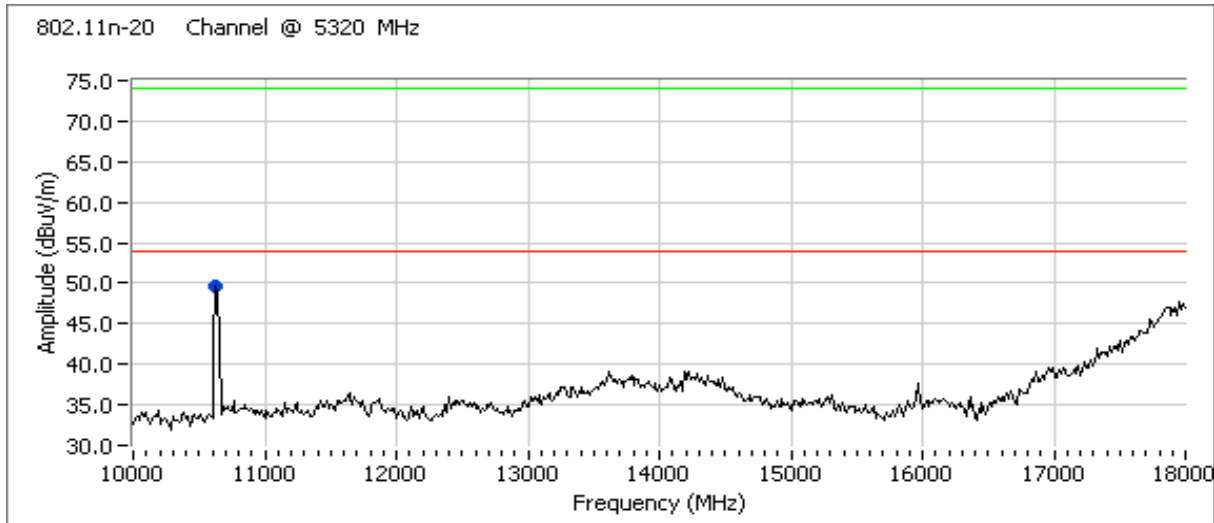

Client: Intel	Job Number: J70979
Model: 512an MMW	T-Log Number: T71043
Contact: Robert Paxman	Account Manager: Briggs / Eriksen
Standard: RSS 210 / FCC 15.407 UNII (Radiated)	Class: N/A

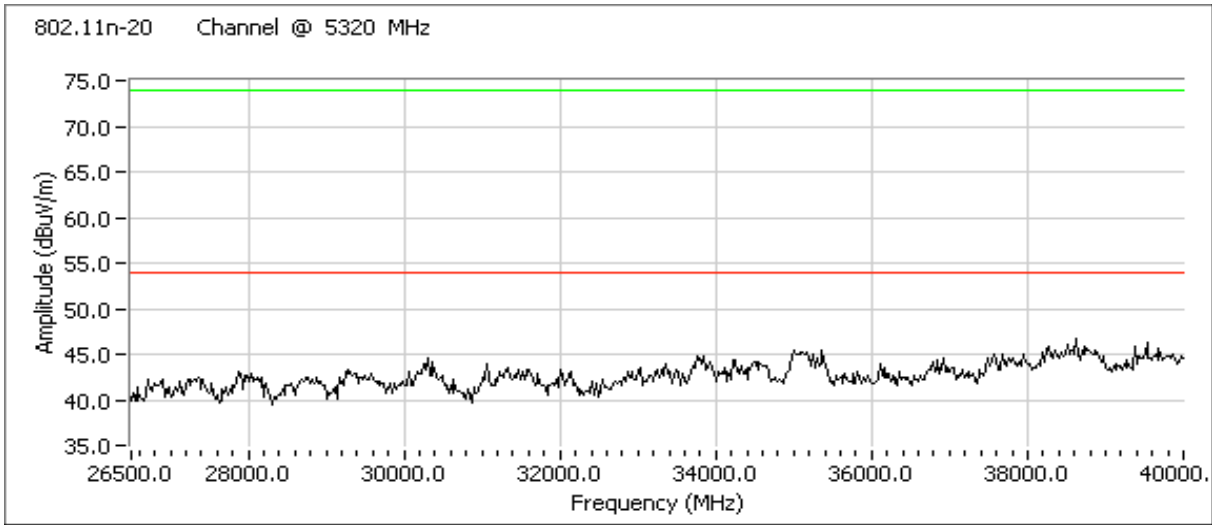

Client: Intel	Job Number: J70979
Model: 512an MMW	T-Log Number: T71043
Contact: Robert Paxman	Account Manager: Briggs / Eriksen
Standard: RSS 210 / FCC 15.407 UNII (Radiated)	Class: N/A

Run #3: Radiated Spurious Emissions, 1000 - 40000 MHz. Operating Mode: 802.11n20 Chain A

Date of Test: 4/9/2008

Test Engineer: Ben Jing

Test Location: Fremont Chamber #3

Run #3a: Low Channel @ 5500 MHz
Spurious Emissions

Frequency MHz	Level dBuV/m	Pol v/h	15.209 / 15.247		Detector Pk/QP/Avg	Azimuth degrees	Height meters	Comments
			Limit	Margin				
2490.480	28.9	V	54.0	-25.1	AVG	231	1.5	
3000.390	48.4	V	68.3	-19.9	AVG	273	1.0	Note 2
6000.770	47.3	V	68.3	-21.0	AVG	261	1.5	Note 2
10999.230	43.8	V	54.0	-10.2	AVG	124	1.0	
2490.480	46.9	V	74.0	-27.1	PK	231	1.5	
3000.390	52.2	V	88.3	-36.1	PK	273	1.0	Note 2
6000.770	50.7	V	88.3	-37.6	PK	261	1.5	Note 2
10999.230	56.2	V	74.0	-17.8	PK	124	1.0	

Note 1: For emissions in restricted bands, the limit of 15.209 was used. For all other emissions, the limit was set to -27dBm eirp (68.3dBuV/m average, 88.3dBuV/m peak)

Note 2: Signal is not in a restricted band.

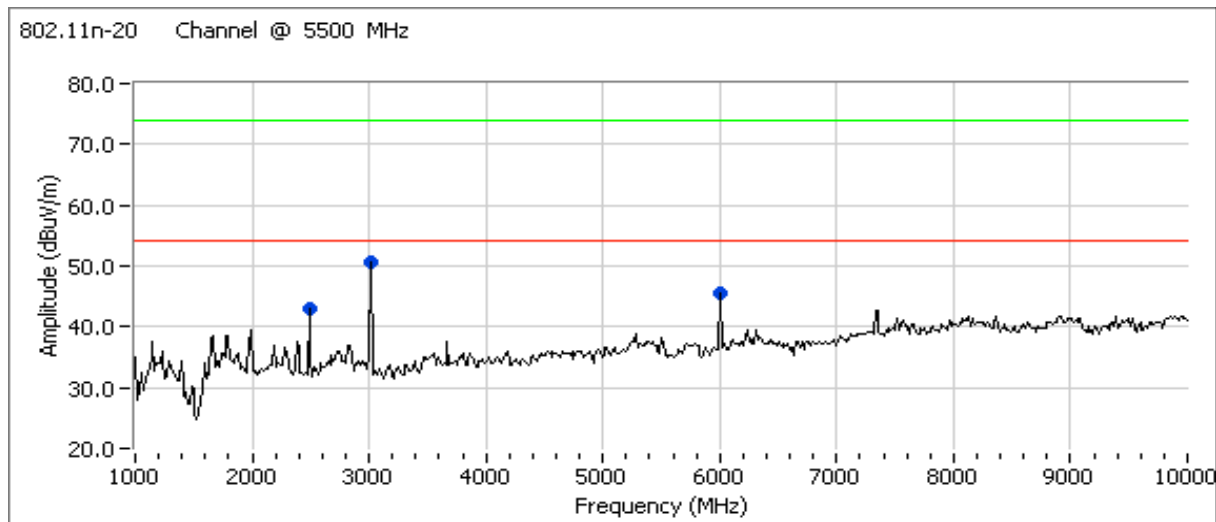

Client: Intel	Job Number: J70979
Model: 512an MMW	T-Log Number: T71043
Contact: Robert Paxman	Account Manager: Briggs / Eriksen
Standard: RSS 210 / FCC 15.407 UNII (Radiated)	Class: N/A

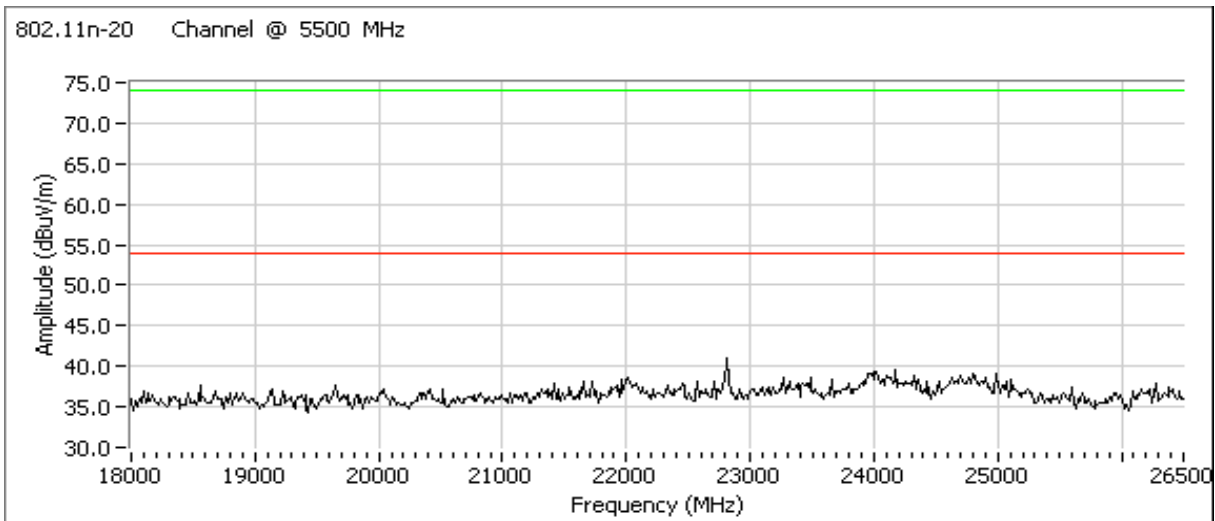
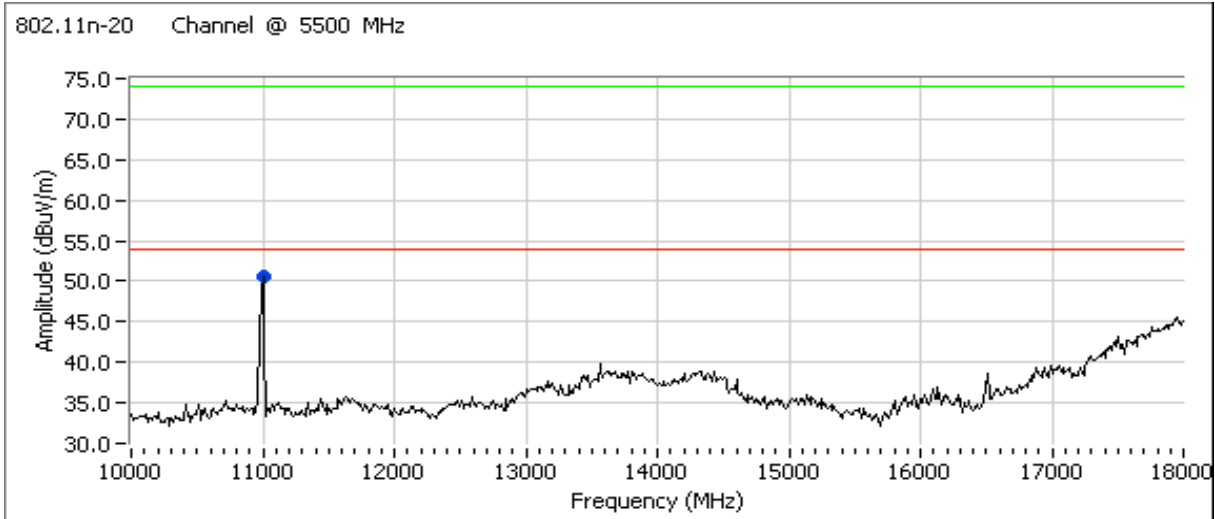

Client:	Intel	Job Number:	J70979
Model:	512an MMW	T-Log Number:	T71043
Contact:	Robert Paxman	Account Manager:	Briggs / Eriksen
Standard:	RSS 210 / FCC 15.407 UNII (Radiated)	Class:	N/A

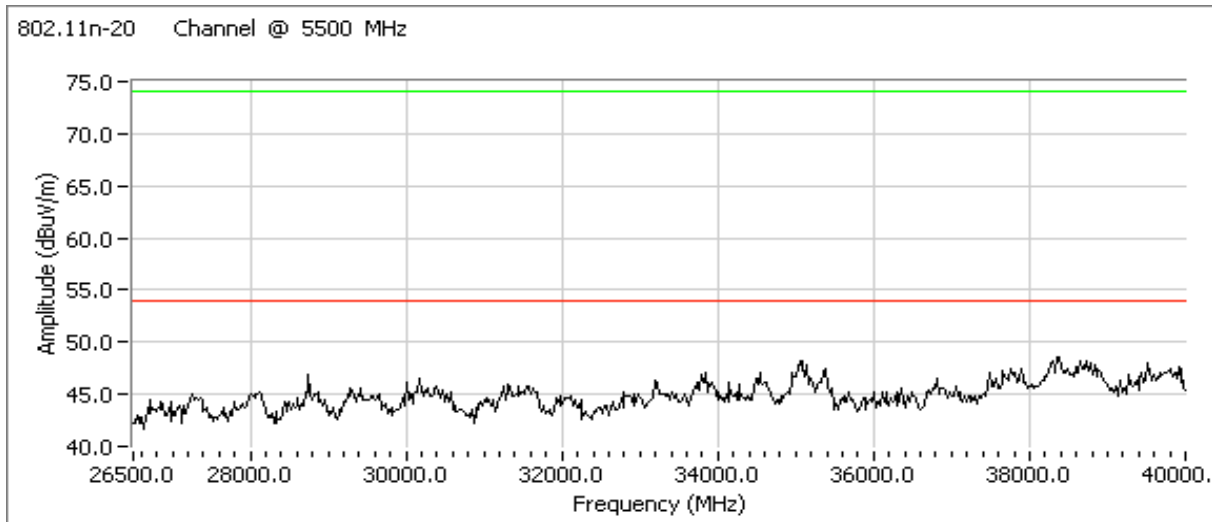

Run #3b: Center Channel @ 5600 MHz
Spurious Emissions

Frequency	Level	Pol	15.209 / 15.247		Detector	Azimuth	Height	Comments
MHz	dBuV/m	v/h	Limit	Margin	Pk/QP/Avg	degrees	meters	
2490.470	29.6	V	54.0	-24.4	AVG	257	1.5	
3000.400	48.1	V	68.3	-20.2	AVG	270	1.0	Note 2
6000.770	47.1	V	68.3	-21.2	AVG	260	1.5	Note 2
11200.090	49.8	V	54.0	-4.2	AVG	124	1.0	
2490.470	49.6	V	74.0	-24.4	PK	257	1.5	
3000.400	51.9	V	88.3	-36.4	PK	270	1.0	Note 2
6000.770	51.2	V	88.3	-37.1	PK	260	1.5	Note 2
11200.090	62.6	V	74.0	-11.4	PK	124	1.0	

Note 1: For emissions in restricted bands, the limit of 15.209 was used. For all other emissions, the limit was set to -27dBm eirp (68.3dBuV/m average, 88.3dBuV/m peak)

Note 2: Signal is not in a restricted band.

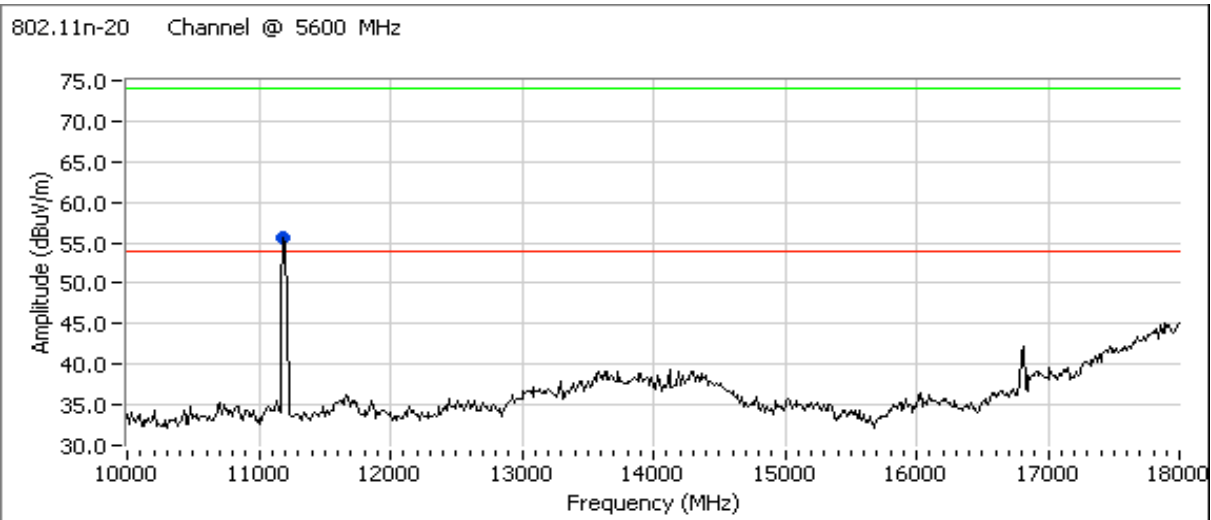
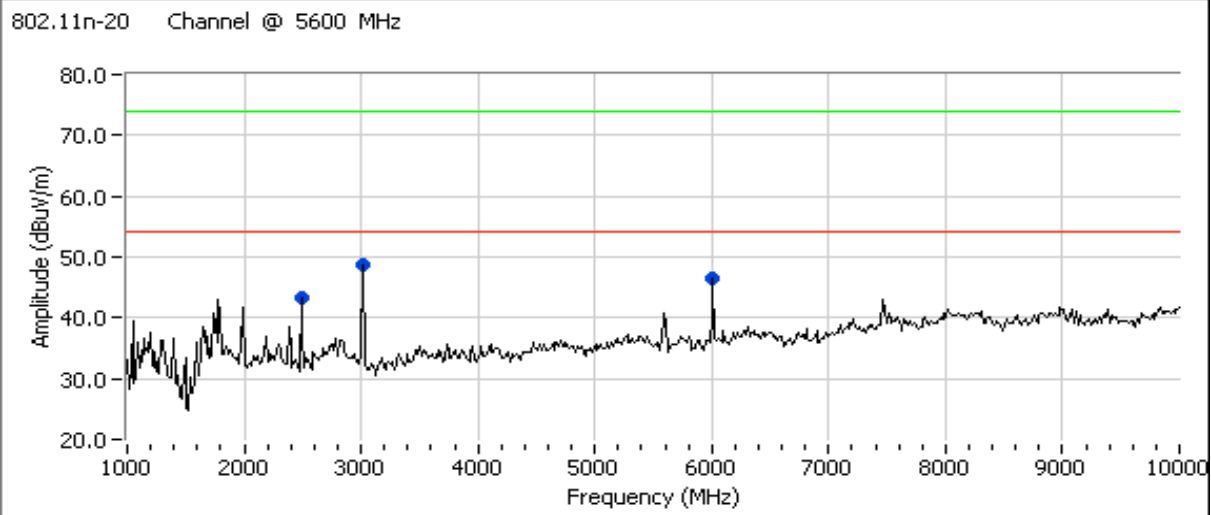
Client: Intel	Job Number: J70979
Model: 512an MMW	T-Log Number: T71043
Contact: Robert Paxman	Account Manager: Briggs / Eriksen
Standard: RSS 210 / FCC 15.407 UNII (Radiated)	Class: N/A



Client: Intel	Job Number: J70979
Model: 512an MMW	T-Log Number: T71043
Contact: Robert Paxman	Account Manager: Briggs / Eriksen
Standard: RSS 210 / FCC 15.407 UNII (Radiated)	Class: N/A

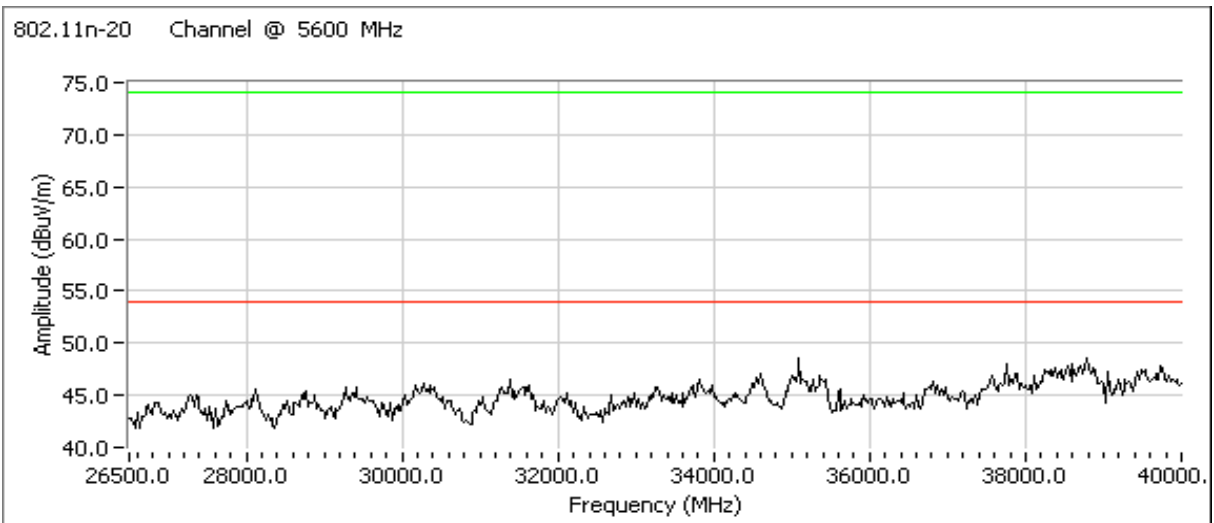
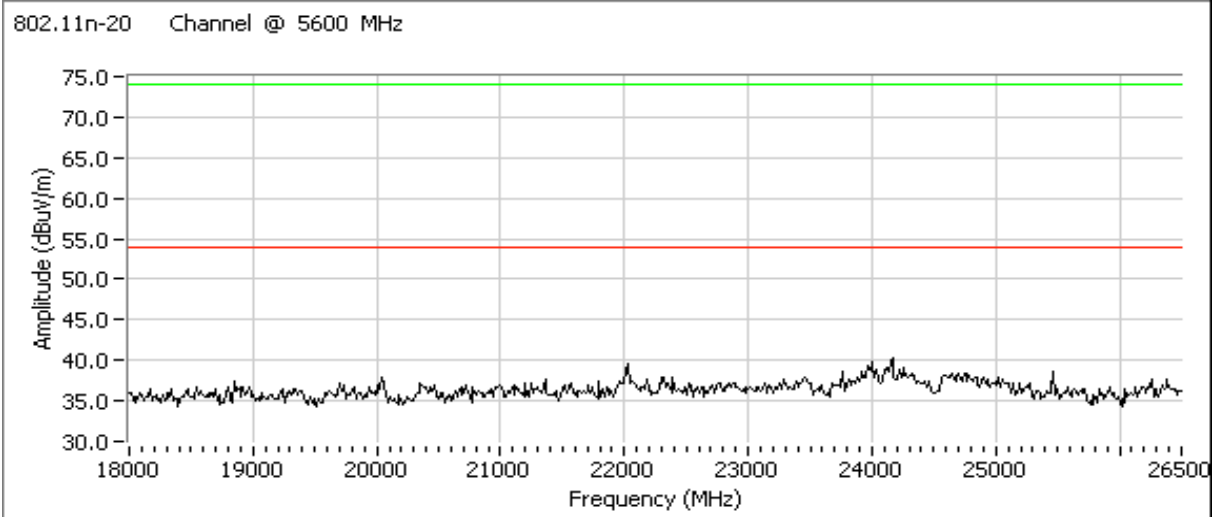

Client: Intel	Job Number: J70979
Model: 512an MMW	T-Log Number: T71043
	Account Manager: Briggs / Eriksen
Contact: Robert Paxman	
Standard: RSS 210 / FCC 15.407 UNII (Radiated)	Class: N/A

Run #3c: High Channel @ 5700 MHz

Spurious Emissions

Frequency MHz	Level dB μ V/m	Pol v/h	15.209 / 15.247		Detector Pk/QP/Avg	Azimuth degrees	Height meters	Comments
			Limit	Margin				
3000.350	49.7	V	68.3	-18.6	AVG	259	1.0	Note 2
6000.740	47.2	V	68.3	-21.1	AVG	262	1.5	Note 2
7599.930	45.4	V	54.0	-8.6	AVG	92	1.5	
11400.040	43.5	V	54.0	-10.5	AVG	132	1.0	
3000.350	53.0	V	88.3	-35.3	PK	259	1.0	Note 2
6000.740	50.5	V	88.3	-37.8	PK	262	1.5	Note 2
7599.930	51.1	V	74.0	-22.9	PK	92	1.5	
11400.040	55.8	V	74.0	-18.2	PK	132	1.0	

Note 1: For emissions in restricted bands, the limit of 15.209 was used. For all other emissions, the limit was set to -27dBm eirp (68.3dBuV/m average, 88.3dBuV/m peak)

Note 2: Signal is not in a restricted band.

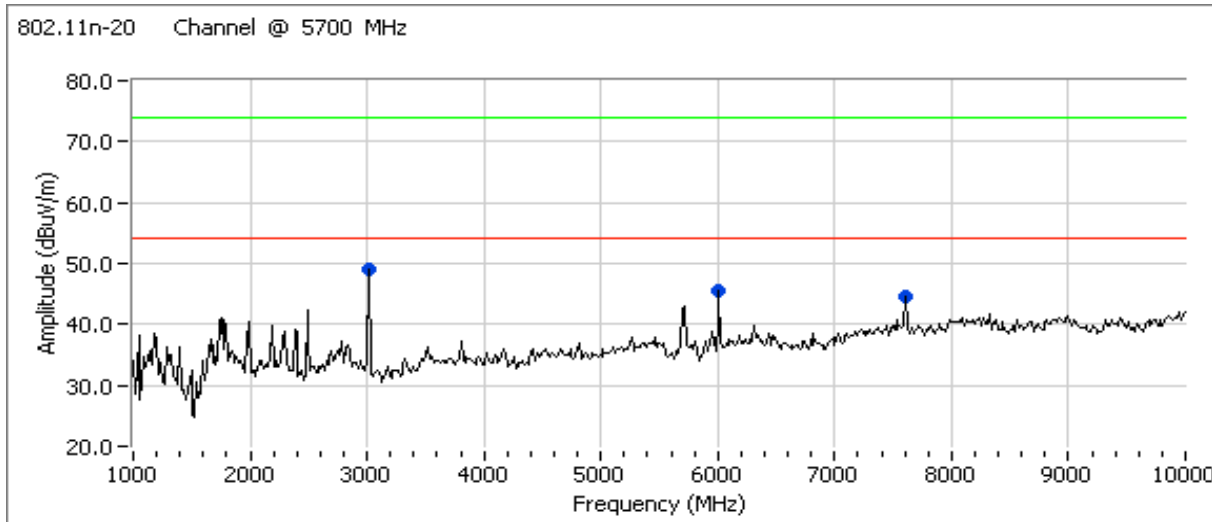

Client: Intel	Job Number: J70979
Model: 512an MMW	T-Log Number: T71043
Contact: Robert Paxman	Account Manager: Briggs / Eriksen
Standard: RSS 210 / FCC 15.407 UNII (Radiated)	Class: N/A

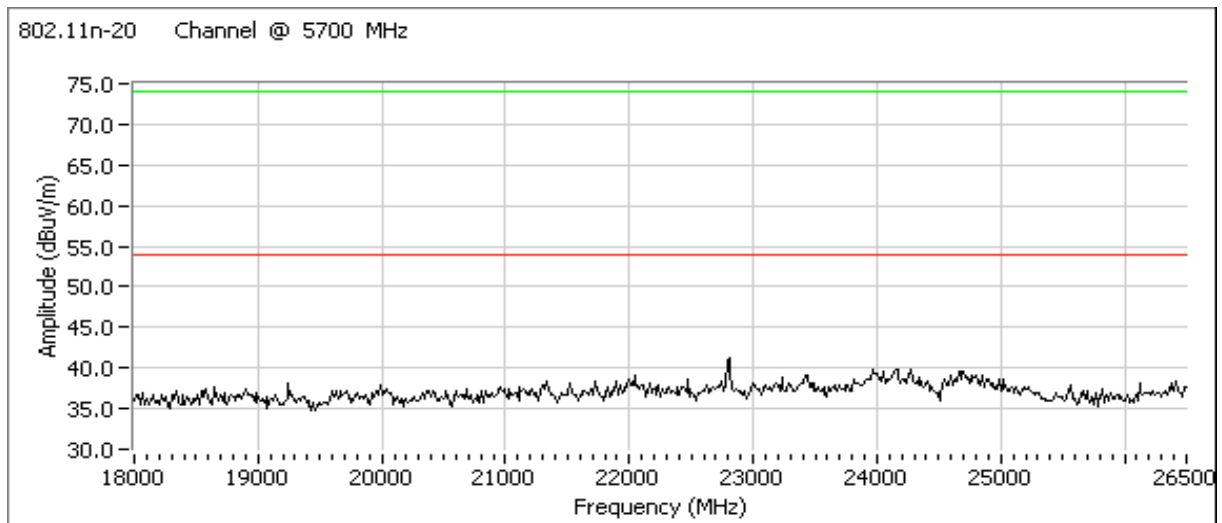
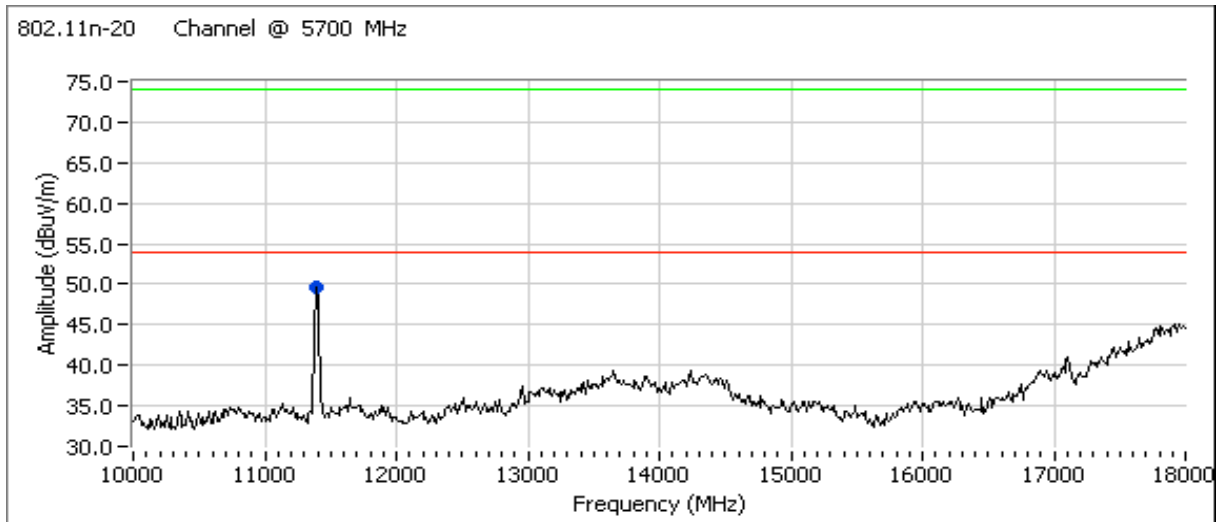

Client: Intel	Job Number: J70979
Model: 512an MMW	T-Log Number: T71043
Contact: Robert Paxman	Account Manager: Briggs / Eriksen
Standard: RSS 210 / FCC 15.407 UNII (Radiated)	Class: N/A

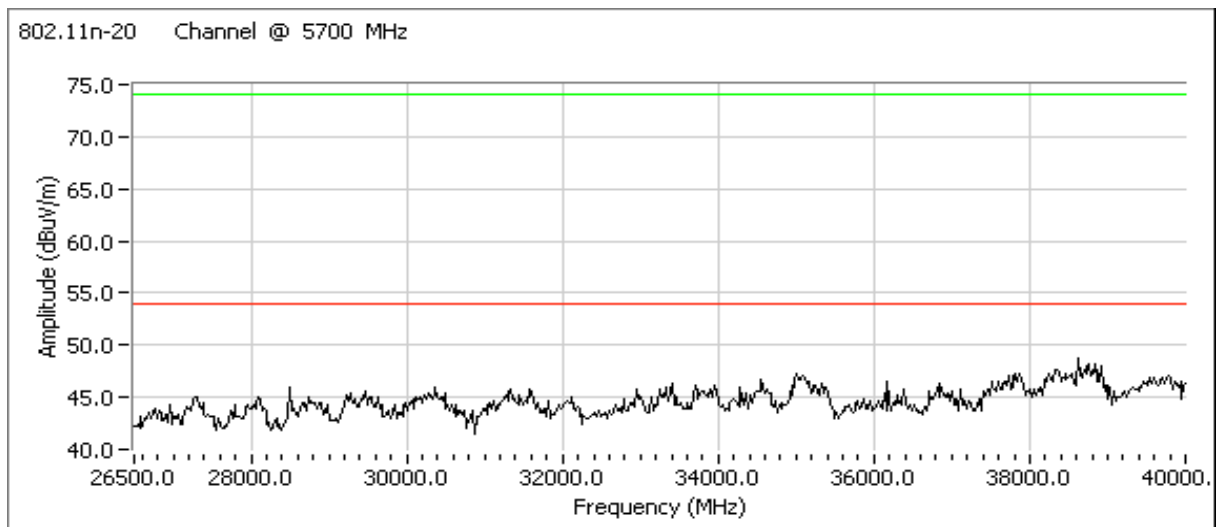

Client:	Intel	Job Number:	J70979
Model:	512an MMW	T-Log Number:	T71043
Contact:	Robert Paxman	Account Manager:	Briggs / Eriksen
Standard:	RSS 210 / FCC 15.407 UNII (Radiated)	Class:	N/A

**RSS 210 and FCC 15.E (U-NII, 5150- 550/5250-5350/5460-5725MHz)
Radiated Spurious Emissions - Band Edge 802.11n 40MHz Mode**

Test Specific Details

Objective: The objective of this test session is to perform final qualification testing of the EUT with respect to the specification listed above.

Date of Test: 3/20/2008
 Test Engineer: Peter Sales
 Test Location: Fremont Chamber #3

Config. Used: 1
 Config Change: None
 Host Unit Voltage 120V/60Hz

General Test Configuration

The EUT and all local support equipment were located on the turntable for radiated spurious emissions testing. All remote support equipment was located approximately 30 meters from the EUT with all I/O connections running on top of the groundplane.

For radiated emissions testing the measurement antenna was located 3 meters from the EUT.

Ambient Conditions: Temperature: 19 °C
 Rel. Humidity: 44 %

Summary of Results

Run #	Mode	Channel	Power Setting	Measured Power	Test Performed	Limit	Result / Margin
1a	802.11n40 Chain A	5190MHz	GC = 26	AP = 15.1	Band Edge radiated field strength	FCC Part 15.209	52.666.5 @ 5149.951 (-1.4dB AVG)
1b	802.11n40 Chain A	5310MHz	GC = 24	AP = 15.7	Band Edge radiated field strength	FCC Part 15.209	51.866.6 @ 5350.053 (-2.2dB AVG)
1c	802.11n40 Chain A	5510MHz	GC = 23.5	AP = 16.2	Band Edge radiated field strength	FCC Part 15.209 / 15E	52.367.2 @ 5460.054 (-1.7dB AVG)

Modifications Made During Testing

No modifications were made to the EUT during testing

Deviations From The Standard

No deviations were made from the requirements of the standard.

Client:	Intel	Job Number:	J70979
Model:	512an MMW	T-Log Number:	T71043
Contact:	Robert Paxman	Account Manager:	Briggs / Eriksen
Standard:	RSS 210 / FCC 15.407 UNII (Radiated)	Class:	N/A

Run #1: Radiated Spurious Emissions, Band Edges. Operating Mode: 802.11n 40MHz - Chain A

Run #1a: Low Channel @ 5190 MHz (band edge at 5150 MHz)

Power Setting: 26.0 Average power: 15.1 (for reference purposes)

Fundamental Signal Field Strength: Peak and average values measured in 1 MHz, for reference only

Frequency	Level	Pol	15.209 / 15.247		Detector	Azimuth	Height	Comments
MHz	dB μ V/m	v/h	Limit	Margin	Pk/QP/Avg	degrees	meters	
5186.600	90.2	V	54.0	36.2	AVG	104	1.9	RB = VB = 1MHz
5186.600	98.6	V	74.0	24.6	PK	104	1.9	RB = 1MHz, VB = 10Hz
5205.600	88.4	H	54.0	34.4	AVG	257	1.1	RB = VB = 1MHz
5205.600	96.5	H	74.0	22.5	PK	257	1.1	RB = 1MHz, VB = 10Hz

Band Edge Signal Field Strength

Frequency	Level	Pol	15.209 / 15.247		Detector	Azimuth	Height	Comments
MHz	dB μ V/m	v/h	Limit	Margin	Pk/QP/Avg	degrees	meters	
5147.970	66.5	V	74.0	-7.5	PK	104	1.9	GC= 26.0, AP=15.1
5149.920	52.6	V	54.0	-1.4	AVG	104	1.9	GC = 26.0, AP=15.1

Log scale - scaling assumes units are dB units with correction factor applied (36.1 @ 5130.0 MHz)

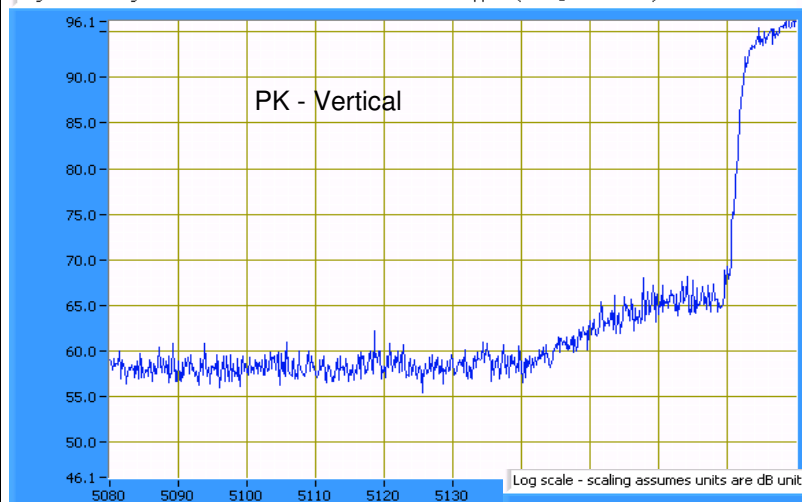

Log scale - scaling assumes units are dB units with correction factor applied (36.1 @ 5130.0 MHz)

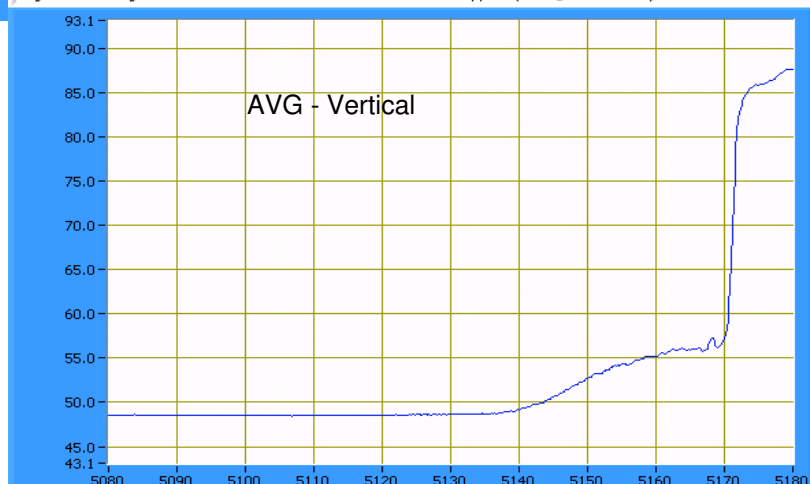

Client:	Intel	Job Number:	J70979
Model:	512an MMW	T-Log Number:	T71043
Contact:	Robert Paxman	Account Manager:	Briggs / Eriksen
Standard:	RSS 210 / FCC 15.407 UNII (Radiated)	Class:	N/A

Run #1b: High Channel @ 5310 MHz (band edge at 5350 MHz)

Power Setting: 24.0 Average power: 15.7 (for reference purposes)

Fundamental Signal Field Strength: Peak and average values measured in 1 MHz, for reference only

Frequency	Level	Pol	15.209 / 15.247		Detector	Azimuth	Height	Comments
MHz	dB μ V/m	v/h	Limit	Margin	Pk/QP/Avg	degrees	meters	
5325.400	88.0	V	54.0	34.0	AVG	93	1.0	RB = VB = 1MHz
5325.400	96.6	V	74.0	22.6	PK	93	1.0	RB = 1MHz, VB = 10Hz
5319.870	81.1	H	54.0	27.1	AVG	93	1.0	RB = VB = 1MHz
5319.870	89.9	H	74.0	15.9	PK	93	1.0	RB = 1MHz, VB = 10Hz

Band Edge Signal Field Strength

Restricted band starts at allocated band edge (5350MHz), field strength limit is 54dBuV/m average, 74dBuV/m peak.

Frequency	Level	Pol	15.209 / 15.247		Detector	Azimuth	Height	Comments
MHz	dB μ V/m	v/h	Limit	Margin	Pk/QP/Avg	degrees	meters	
5351.010	66.6	V	74.0	-7.4	PK	93	1.0	GC = 24.0, AP = 15.7
5350.000	51.8	V	54.0	-2.2	AVG	93	1.0	GC = 24.0, AP = 15.7

Log scale - scaling assumes units are dB units with correction factor applied (36.6 @ 5370.0 MHz)

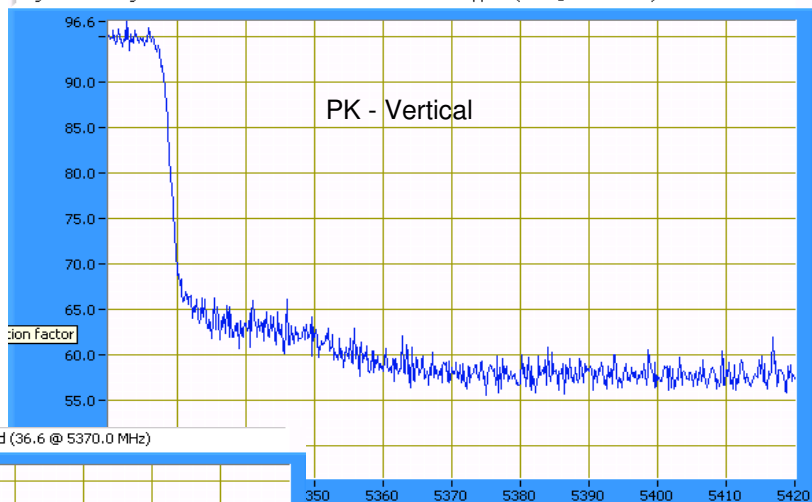

Log scale - scaling assumes units are dB units with correction factor applied (36.6 @ 5370.0 MHz)

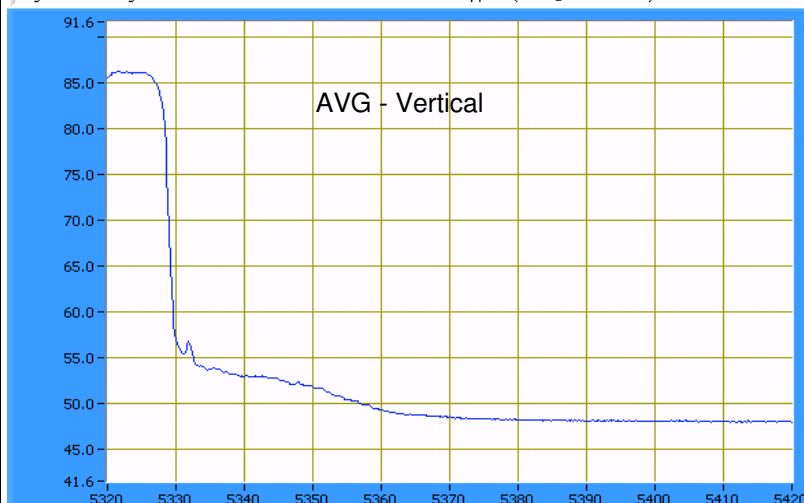

Client:	Intel	Job Number:	J70979
Model:	512an MMW	T-Log Number:	T71043
Contact:	Robert Paxman	Account Manager:	Briggs / Eriksen
Standard:	RSS 210 / FCC 15.407 UNII (Radiated)	Class:	N/A

Run #1c: Low Channel @ 5510 MHz (restricted band edge at 5460 MHz, allocated band edge at 5470MHz)

Power Setting: 23.5 Average power: 16.2 (for reference purposes)

Fundamental Signal Field Strength: Peak and average values measured in 1 MHz, for reference only

Frequency MHz	Level dB μ V/m	Pol v/h	15.209 / 15.247		Detector Pk/QP/Avg	Azimuth degrees	Height meters	Comments
			Limit	Margin				
5494.330	94.8	V	-	-	AVG	103	1.0	RB = VB = 1MHz
5494.330	102.9	V	-	-	PK	103	1.0	RB = 1MHz, VB = 10Hz
5494.400	85.9	H	-	-	AVG	77	1.0	RB = VB = 1MHz
5494.400	94.6	H	-	-	PK	77	1.0	RB = 1MHz, VB = 10Hz

5460 Restricted Band Feld strength limit = 54dBuV/m avg, 74dBuV/m peak at 3m

5460 - 5470 MHz, Limit is -27dBm eirp (68.3dBuV/m average, 88.3dBuV/m peak at 3m)

Frequency MHz	Level dB μ V/m	Pol v/h	15.209 / 15.247		Detector Pk/QP/Avg	Azimuth degrees	Height meters	Comments
			Limit	Margin				
5457.170	67.2	V	74.0	-6.8	PK	103	1.0	GC = 23.5, AP = 16.2
5459.980	52.3	V	54.0	-1.7	AVG	103	1.0	GC = 23.5, AP = 16.2

Log scale - scaling assumes units are dB units with correction factor applied (36.7 @ 5450.0 MHz)

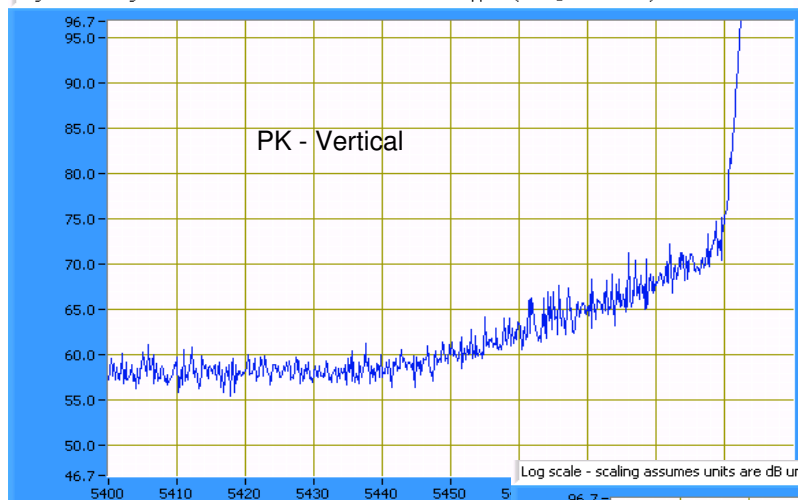

Log scale - scaling assumes units are dB units with correction factor applied (36.7 @ 5450.0 MHz)

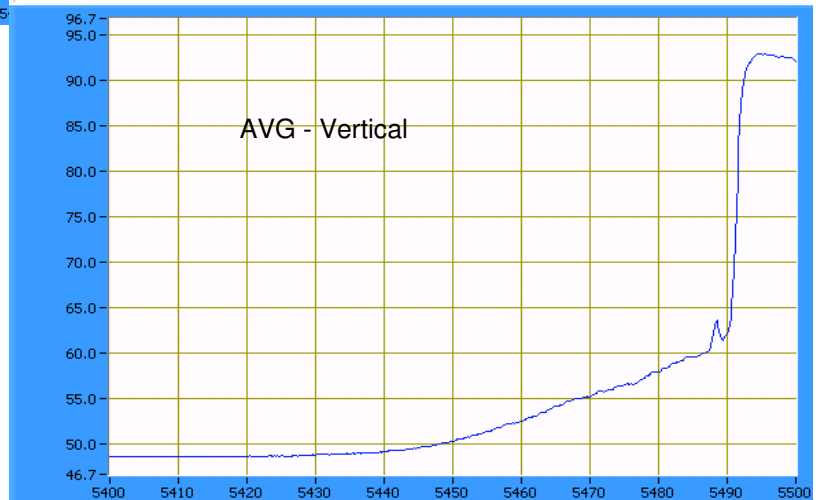

Client:	Intel	Job Number:	J70979
Model:	512an MMW	T-Log Number:	T71043
Contact:	Robert Paxman	Account Manager:	Briggs / Eriksen
Standard:	RSS 210 / FCC 15.407 UNII (Radiated)	Class:	N/A

RSS 210 and FCC 15.E (U-NII, 5150- 550/5250-5350/5460-5725MHz) Radiated Spurious Emissions, 1 - 40GHz 802.11n 40MHz Mode

Test Specific Details

Objective: The objective of this test session is to perform final qualification testing of the EUT with respect to the specification listed above.

Date of Test:	4/9/2008, 4/10/2008	Config. Used:	1
Test Engineer:	Ben Jing Peter Sales	Config Change:	None
Test Location:	Fremont Chamber #3	Host Unit Voltage	120V/60Hz

General Test Configuration

The EUT and all local support equipment were located on the turntable for radiated spurious emissions testing. All remote support equipment was located approximately 30 meters from the EUT with all I/O connections running on top of the groundplane.

For radiated emissions testing the measurement antenna was located 3 meters from the EUT.

Ambient Conditions:	Temperature:	20 °C
	Rel. Humidity:	36 %

Summary of Results

Run #	Mode	Channel	Power Setting	Measured Power	Test Performed	Limit	Result / Margin
1	802.11n40 Chain A	5190 5230	26.5 26.0	16.5 16.6	Radiated Emissions, 1 - 40 GHz	FCC Part 15.209 / 15.407(c)	51.2dBµV/m @ 10460.0MHz (-17.1dB)
2	802.11n40 Chain A	5270 5310	25.5 25.0	16.7 16.5	Radiated Emissions, 1 - 40 GHz	FCC Part 15.209 / 15.407(c)	55.5dBµV/m @ 10611.5MHz (-6.0dB)
3	802.11n40 Chain A	5510 5590 5670	23.5 23.0 26.5	16.6 16.9 16.9	Radiated Emissions, 1 - 40 GHz	FCC Part 15.209 / 15.407(c)	50.7dBµV/m @ 11179.7MHz (-3.3dB)

Modifications Made During Testing

No modifications were made to the EUT during testing

Deviations From The Standard

No deviations were made from the requirements of the standard.

Client: Intel	Job Number: J70979
Model: 512an MMW	T-Log Number: T71043
	Account Manager: Briggs / Eriksen
Contact: Robert Paxman	
Standard: RSS 210 / FCC 15.407 UNII (Radiated)	Class: N/A

Run #1: Radiated Spurious Emissions, 1000 - 40000 MHz. Operating Mode: 802.11n 40MHz Chain A

Run #1a: Low Channel @ 5190 MHz

Spurious Emissions

Frequency MHz	Level dB μ V/m	Pol v/h	15.209 / 15.247		Detector Pk/QP/Avg	Azimuth degrees	Height meters	Comments
			Limit	Margin				
3000.400	49.7	V	68.3	-18.6	AVG	264	1.0	Note 2
6000.710	48.0	V	68.3	-20.3	AVG	260	1.5	Note 2
6920.000	45.5	V	68.3	-22.8	AVG	140	2.0	Note 2
10399.390	42.2	V	68.3	-26.1	AVG	96	1.0	Note 2
3000.400	52.9	V	88.3	-35.4	PK	264	1.0	Note 2
6000.710	51.5	V	88.3	-36.8	PK	260	1.5	Note 2
6920.000	49.5	V	88.3	-38.8	PK	140	2.0	Note 2
10399.390	53.9	V	88.3	-34.4	PK	96	1.0	Note 2

Note 1: For emissions in restricted bands, the limit of 15.209 was used. For all other emissions, the limit was set to -27dBm eirp (68.3dB μ V/m average, 88.3dB μ V/m peak)

Note 2: Signal is not in a restricted band

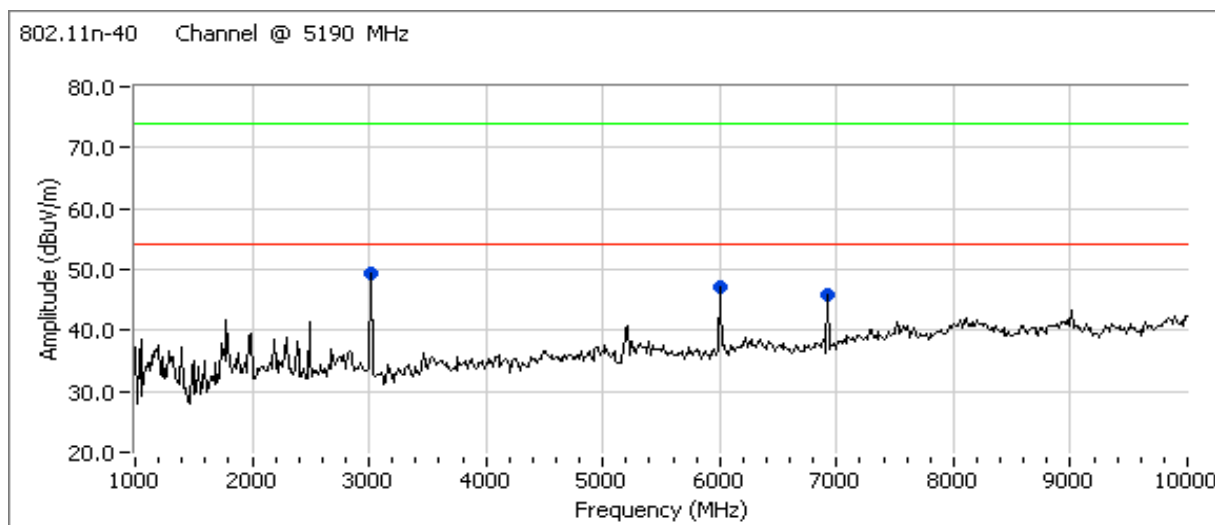

Client: Intel	Job Number: J70979
Model: 512an MMW	T-Log Number: T71043
Contact: Robert Paxman	Account Manager: Briggs / Eriksen
Standard: RSS 210 / FCC 15.407 UNII (Radiated)	Class: N/A

802.11n-40 Channel @ 5190 MHz

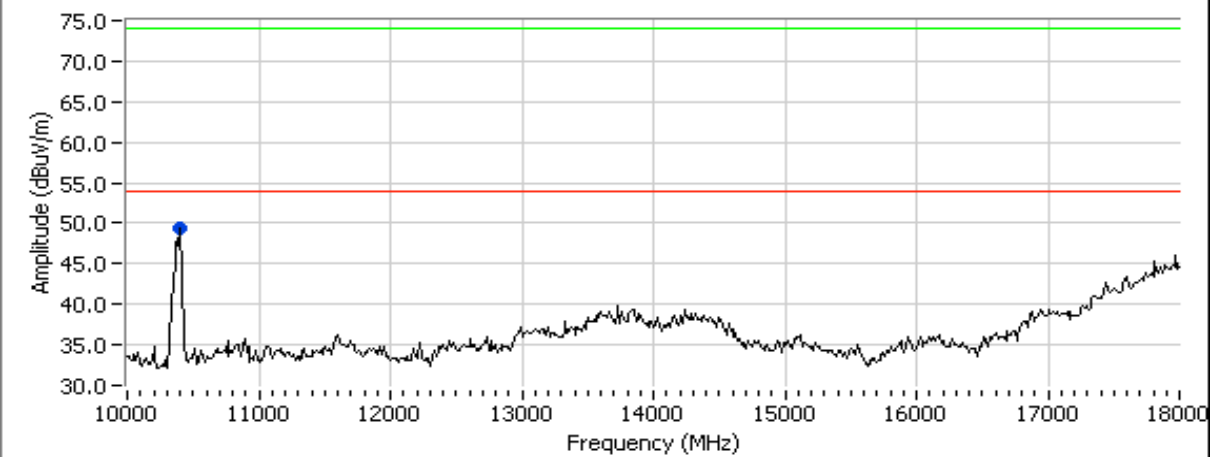

802.11n-40 Channel @ 5190 MHz

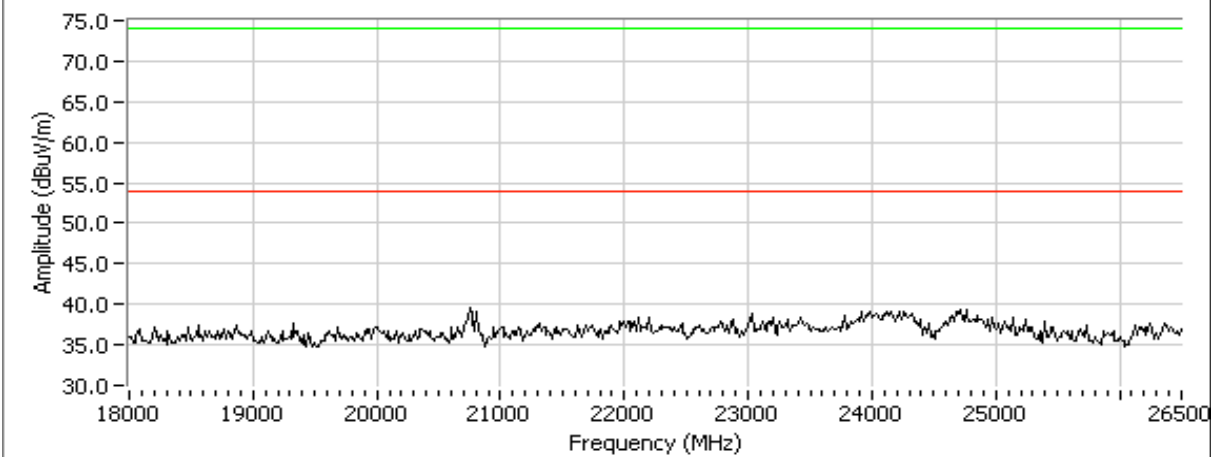

Client:	Intel	Job Number:	J70979
Model:	512an MMW	T-Log Number:	T71043
Contact:	Robert Paxman	Account Manager:	Briggs / Eriksen
Standard:	RSS 210 / FCC 15.407 UNII (Radiated)	Class:	N/A

802.11n-40 Channel @ 5190 MHz

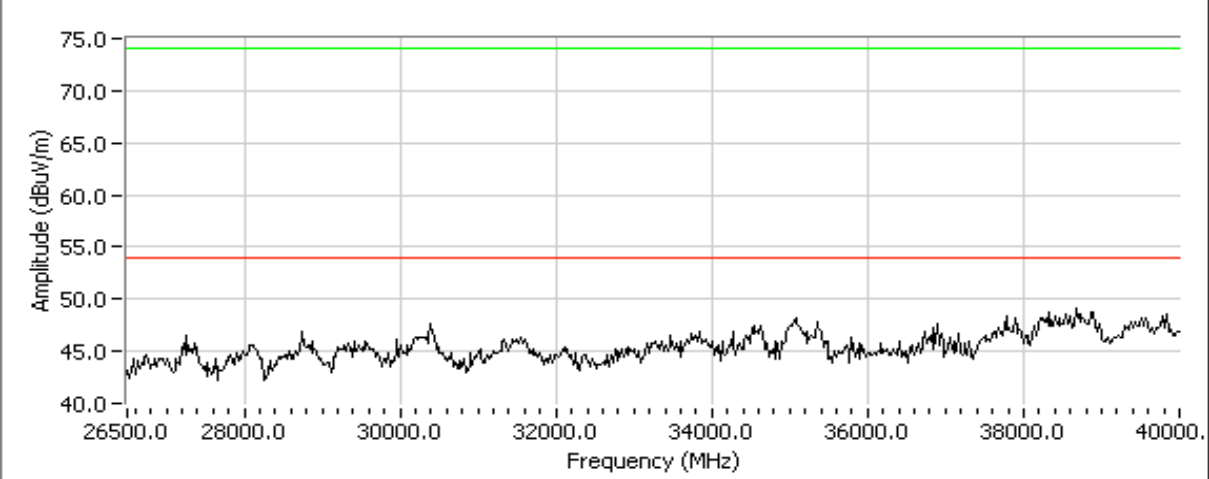

Client:	Intel	Job Number:	J70979
Model:	512an MMW	T-Log Number:	T71043
Contact:	Robert Paxman	Account Manager:	Briggs / Eriksen
Standard:	RSS 210 / FCC 15.407 UNII (Radiated)	Class:	N/A

Run #1b: High Channel @ 5230 MHz

Spurious Emissions

Frequency MHz	Level dB μ V/m	Pol v/h	15.209 / 15.247		Detector Pk/QP/Avg	Azimuth degrees	Height meters	Comments
			Limit	Margin				
3000.380	49.6	V	68.3	-18.7	AVG	262	1.0	Note 2
6000.750	47.5	V	68.3	-20.8	AVG	264	1.5	Note 2
6973.290	50.0	V	68.3	-18.3	AVG	106	1.5	Note 2
10460.030	51.2	V	68.3	-17.1	AVG	110	1.0	Note 2
3000.380	52.9	V	88.3	-35.4	PK	262	1.0	Note 2
6000.750	50.9	V	88.3	-37.4	PK	264	1.5	Note 2
6973.290	52.5	V	88.3	-35.8	PK	106	1.5	Note 2
10460.030	63.2	V	88.3	-25.1	PK	110	1.0	Note 2

Note 1: For emissions in restricted bands, the limit of 15.209 was used. For all other emissions, the limit was set to -27dBm eirp (68.3dBuV/m average, 88.3dBuV/m peak)

Note 2: Signal is not in a restricted band.

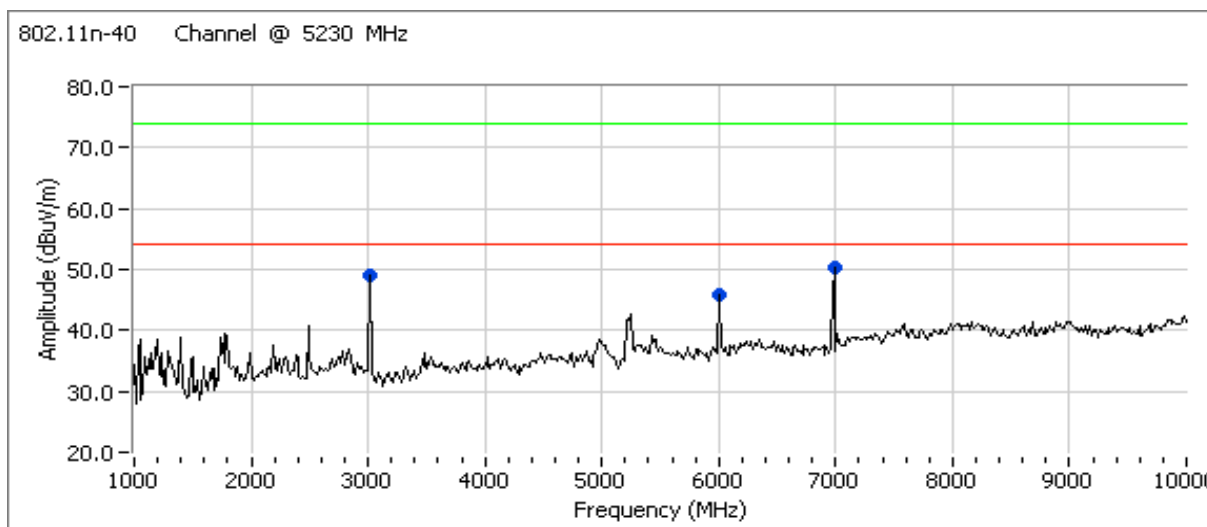

Client:	Intel	Job Number:	J70979
Model:	512an MMW	T-Log Number:	T71043
Contact:	Robert Paxman	Account Manager:	Briggs / Eriksen
Standard:	RSS 210 / FCC 15.407 UNII (Radiated)	Class:	N/A

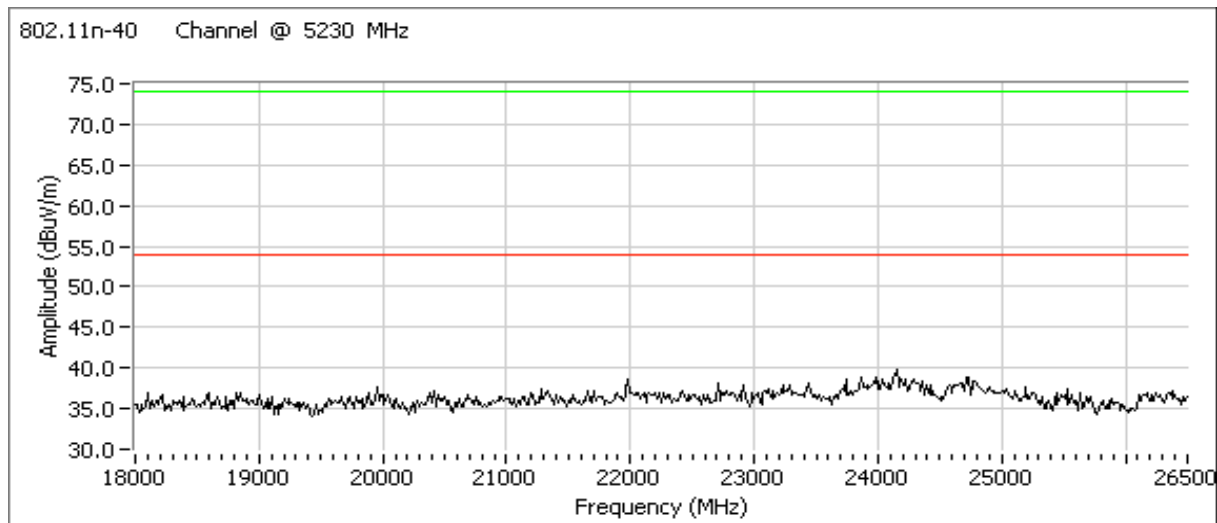
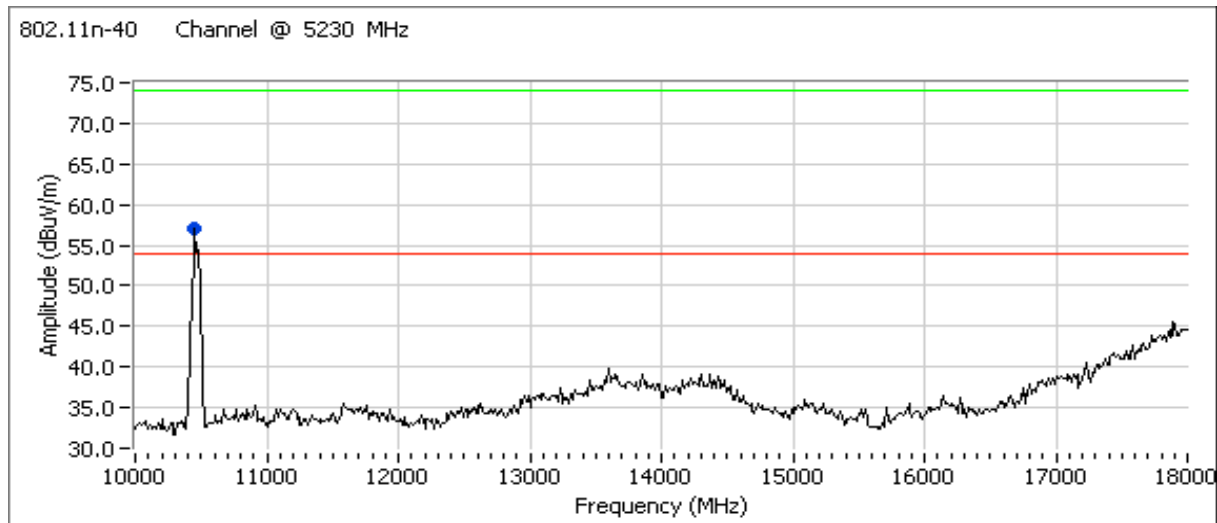

No emissions from 26 - 40GHz

Client:	Intel	Job Number:	J70979
Model:	512an MMW	T-Log Number:	T71043
Contact:	Robert Paxman	Account Manager:	Briggs / Eriksen
Standard:	RSS 210 / FCC 15.407 UNII (Radiated)	Class:	N/A

Run #2: Radiated Spurious Emissions, 1000 - 40000 MHz. Operating Mode: 802.11n40 Chain A
Run #2a: Low Channel @ 5270 MHz
Spurious Emissions

Frequency MHz	Level dB μ V/m	Pol v/h	15.209 / 15.247		Detector Pk/QP/Avg	Azimuth degrees	Height meters	Comments
			Limit	Margin				
3000.410	50.1	V	68.3	-18.2	AVG	259	1.0	Note 2
6000.680	47.9	V	68.3	-20.4	AVG	263	1.5	Note 2
7026.660	44.8	V	68.3	-23.5	AVG	126	1.5	Note 2
10540.070	51.1	V	68.3	-17.2	AVG	109	1.0	Note 2
3000.410	53.5	V	88.3	-34.8	PK	259	1.0	Note 2
6000.680	51.7	V	88.3	-36.6	PK	263	1.5	Note 2
7026.660	49.4	V	88.3	-38.9	PK	126	1.5	Note 2
10540.070	62.4	V	88.3	-25.9	PK	109	1.0	Note 2

Note 1: For emissions in restricted bands, the limit of 15.209 was used. For all other emissions, the limit was set to -27dBm eirp (68.3dBuV/m average, 88.3dBuV/m peak)

Note 2: Signal is not in a restricted band.

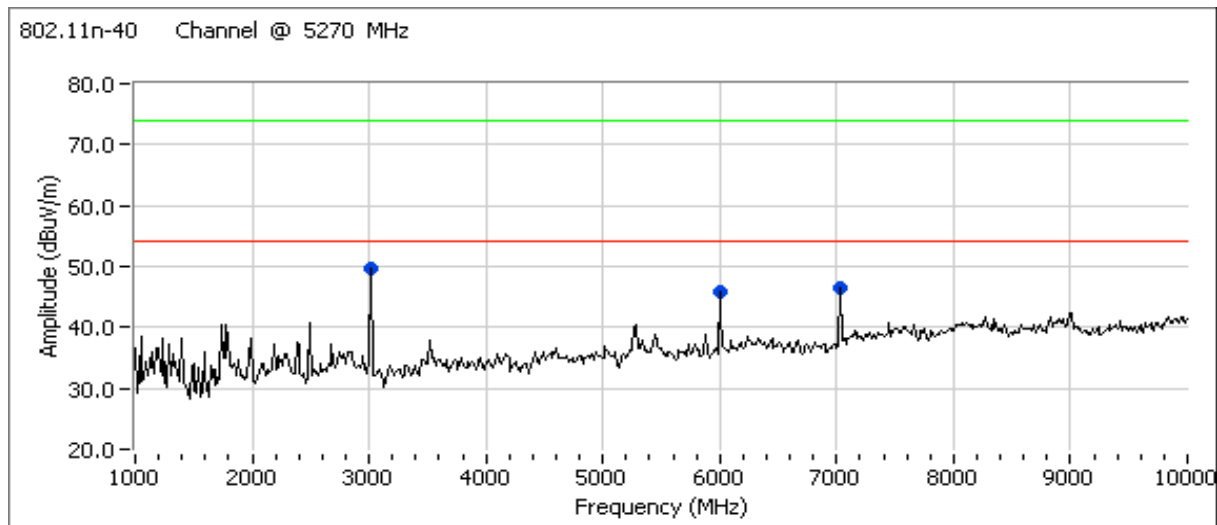

Client: Intel	Job Number: J70979
Model: 512an MMW	T-Log Number: T71043
Contact: Robert Paxman	Account Manager: Briggs / Eriksen
Standard: RSS 210 / FCC 15.407 UNII (Radiated)	Class: N/A

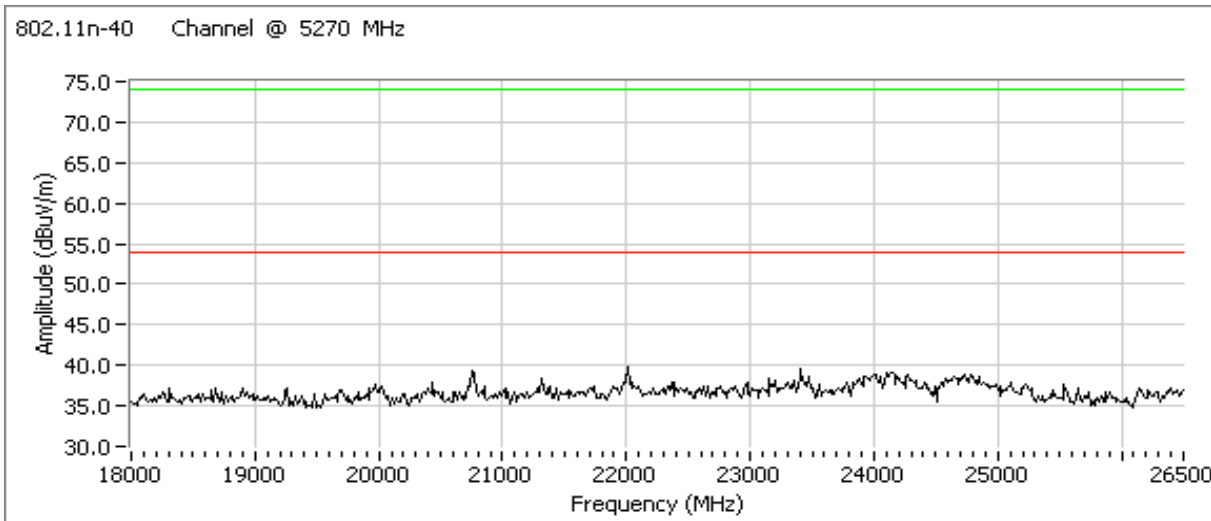
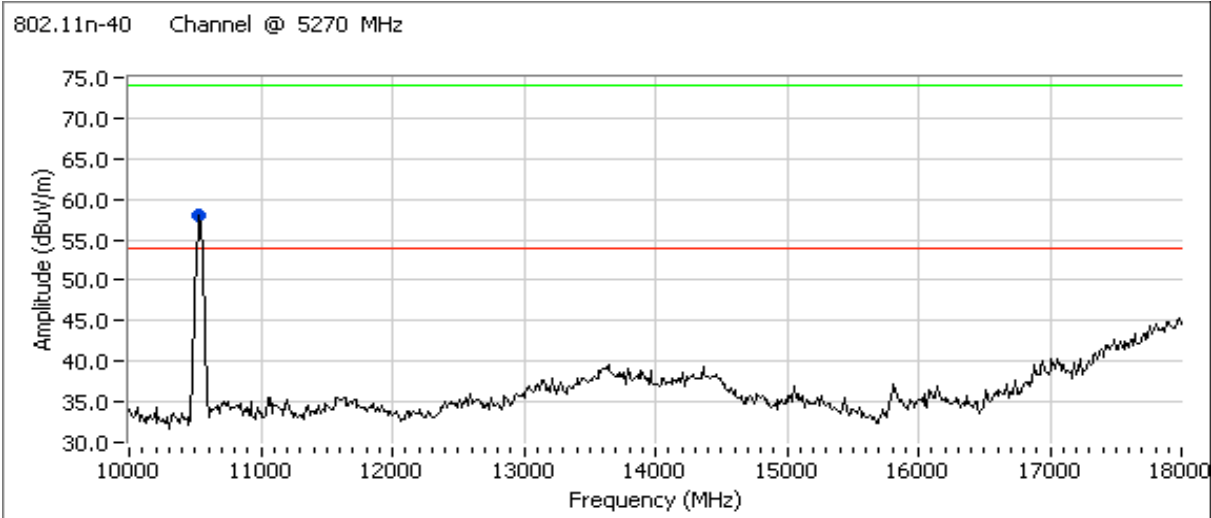

No emissions from 26 - 40GHz

Client:	Intel	Job Number:	J70979
Model:	512an MMW	T-Log Number:	T71043
Contact:	Robert Paxman	Account Manager:	Briggs / Eriksen
Standard:	RSS 210 / FCC 15.407 UNII (Radiated)	Class:	N/A

Run #2b: High Channel @ 5310 MHz
Spurious Emissions

Frequency MHz	Level dB μ V/m	Pol v/h	15.209 / 15.247		Detector Pk/QP/Avg	Azimuth degrees	Height meters	Comments
			Limit	Margin				
3000.410	50.0	V	68.3	-18.3	AVG	263	1.0	Note 2
6000.740	48.0	V	68.3	-20.3	AVG	263	1.5	Note 2
7079.950	43.1	V	68.3	-25.2	AVG	240	1.5	Note 2
10611.490	44.0	V	54.0	-10.0	AVG	233	1.0	
3000.410	53.3	V	88.3	-35.0	PK	263	1.0	Note 2
6000.740	51.5	V	88.3	-36.8	PK	263	1.5	Note 2
7079.950	48.4	V	88.3	-39.9	PK	240	1.5	Note 2
10611.490	55.5	V	54.0	-6.0	PK	233	1.0	

Note 1: For emissions in restricted bands, the limit of 15.209 was used. For all other emissions, the limit was set to -27dBm eirp (68.3dBuV/m average, 88.3dBuV/m peak)

Note 2: Signal is not in a restricted band.

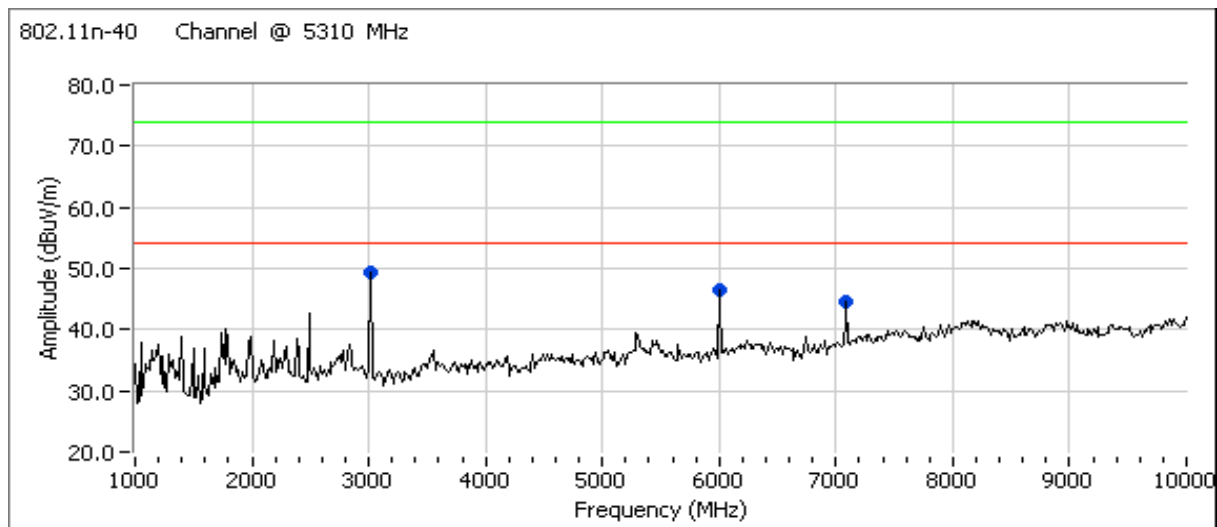

Client:	Intel	Job Number:	J70979
Model:	512an MMW	T-Log Number:	T71043
Contact:	Robert Paxman	Account Manager:	Briggs / Eriksen
Standard:	RSS 210 / FCC 15.407 UNII (Radiated)	Class:	N/A

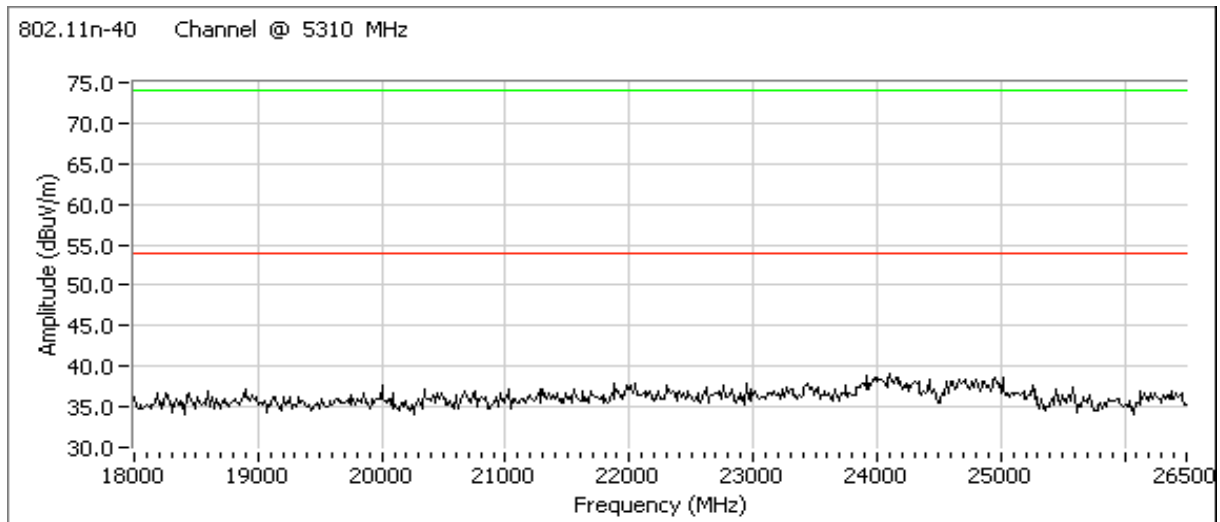
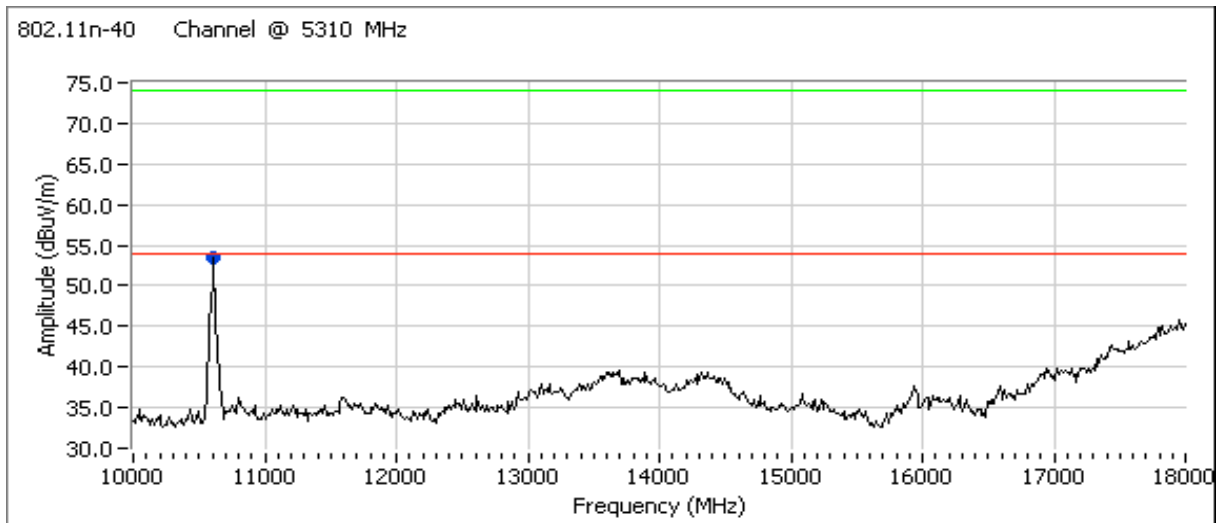

Client:	Intel	Job Number:	J70979
Model:	512an MMW	T-Log Number:	T71043
Contact:	Robert Paxman	Account Manager:	Briggs / Eriksen
Standard:	RSS 210 / FCC 15.407 UNII (Radiated)	Class:	N/A

Run #3: Radiated Spurious Emissions, 1000 - 40000 MHz. Operating Mode: 802.11n40 Chain A
Run #3a: Low Channel @ 5510 MHz
Spurious Emissions

Frequency MHz	Level dB μ V/m	Pol v/h	15.209 / 15.247		Detector Pk/QP/Avg	Azimuth degrees	Height meters	Comments
			Limit	Margin				
2490.630	31.2	H	54.0	-22.8	AVG	146	1.0	
3000.410	48.3	V	68.3	-20.0	AVG	267	1.0	Note 2
7346.630	41.4	V	54.0	-12.6	AVG	224	1.3	
11019.610	48.7	V	54.0	-5.3	AVG	226	1.3	
2490.630	50.7	H	74.0	-23.3	PK	146	1.0	
3000.410	52.4	V	88.3	-35.9	PK	267	1.0	Note 2
7346.630	48.5	V	74.0	-25.5	PK	224	1.3	
11019.610	61.1	V	74.0	-12.9	PK	226	1.3	

Note 1: For emissions in restricted bands, the limit of 15.209 was used. For all other emissions, the limit was set to -27dBm eirp (68.3dB μ V/m average, 88.3dB μ V/m peak)

Note 2: Signal is not in a restricted band.

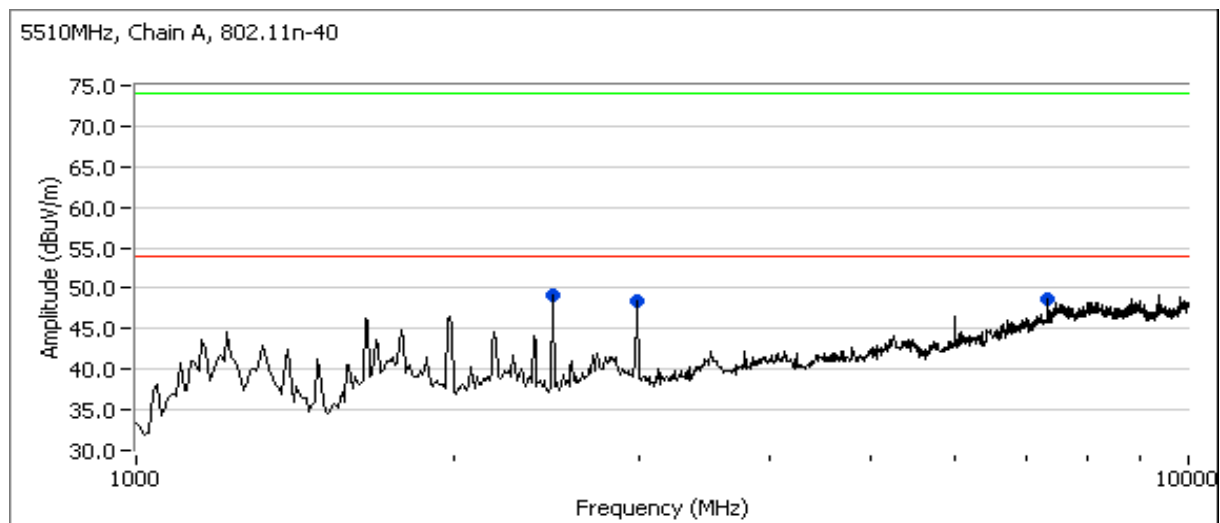

Client:	Intel	Job Number:	J70979
Model:	512an MMW	T-Log Number:	T71043
Contact:	Robert Paxman	Account Manager:	Briggs / Eriksen
Standard:	RSS 210 / FCC 15.407 UNII (Radiated)	Class:	N/A

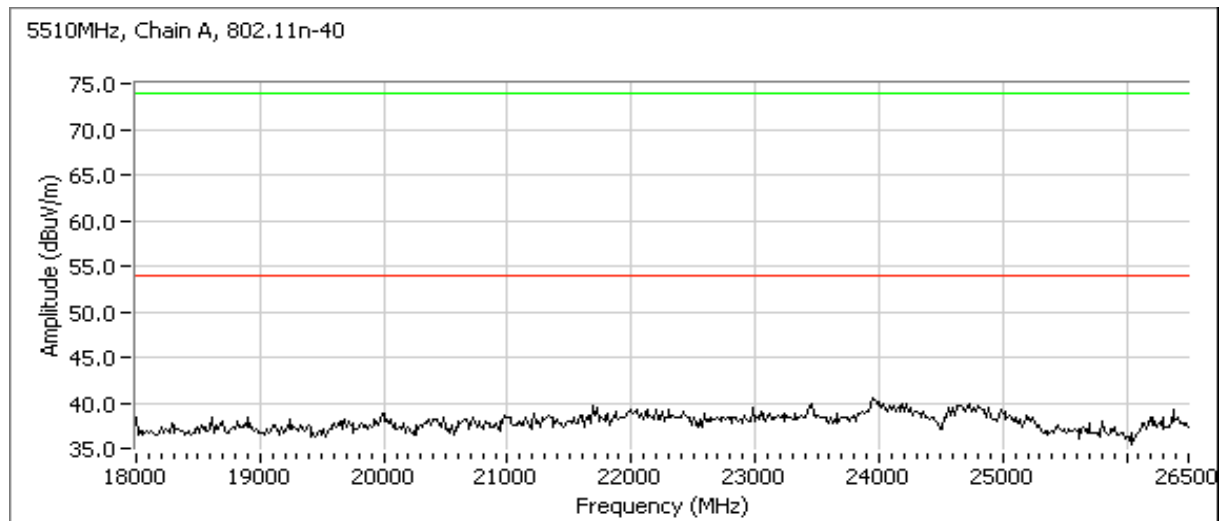
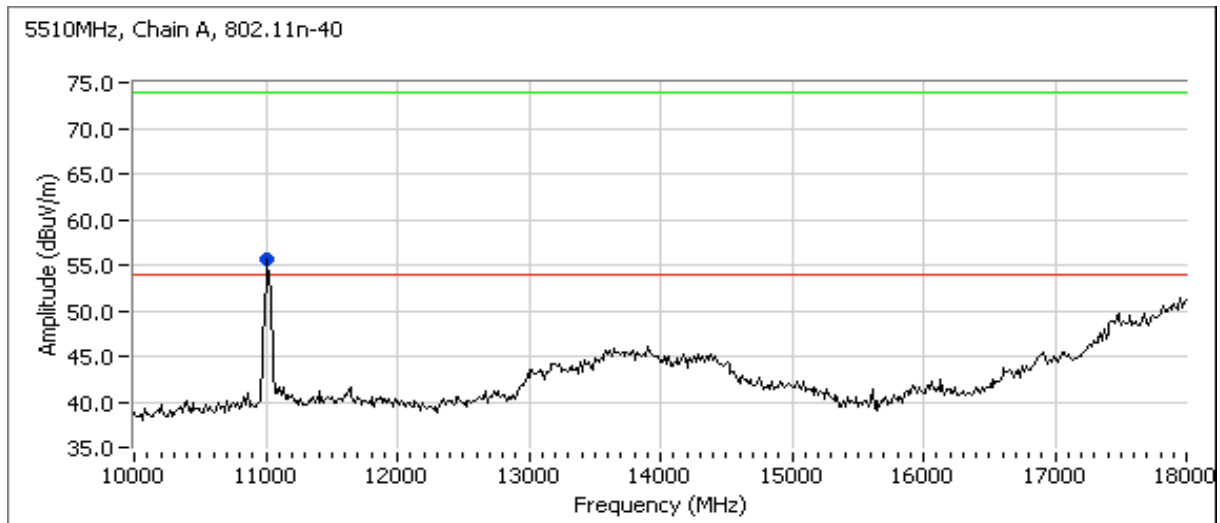

Client:	Intel	Job Number:	J70979
Model:	512an MMW	T-Log Number:	T71043
Contact:	Robert Paxman	Account Manager:	Briggs / Eriksen
Standard:	RSS 210 / FCC 15.407 UNII (Radiated)	Class:	N/A

Run #3b: Center Channel @ 5590 MHz
Spurious Emissions

Frequency MHz	Level dB μ V/m	Pol v/h	15.209 / 15.247		Detector Pk/QP/Avg	Azimuth degrees	Height meters	Comments
			Limit	Margin				
3000.270	48.5	V	68.3	-19.8	AVG	183	1.0	Note 2
6000.690	48.0	V	68.3	-20.3	AVG	273	1.9	Note 2
11179.700	50.7	V	54.0	-3.3	AVG	218	1.0	
16870.510	37.0	V	68.3	-31.3	AVG	121	1.0	
38239.250	40.2	V	54.0	-13.8	AVG	333	1.9	
38660.610	41.6	V	68.3	-26.7	AVG	57	1.6	Note 2 Noise floor
38990.050	40.6	H	68.3	-27.7	AVG	105	1.0	Note 2 Noise floor
3000.270	52.6	V	88.3	-35.7	PK	183	1.0	Note 2
6000.690	52.8	V	88.3	-35.5	PK	273	1.9	Note 2
11179.700	62.5	V	74.0	-11.5	PK	218	1.0	
16870.510	47.9	V	88.3	-40.4	PK	121	1.0	Note 2
38239.250	51.9	V	88.3	-36.4	PK	333	1.9	Note 2 Noise floor
38660.610	53.3	V	88.3	-35.0	PK	57	1.6	Note 2 Noise floor
38990.050	52.1	H	88.3	-36.2	PK	105	1.0	Note 2 Noise floor

Note 1: For emissions in restricted bands, the limit of 15.209 was used. For all other emissions, the limit was set to -27dBm eirp (68.3dBuV/m average, 88.3dBuV/m peak)

Note 2: Signal is not in a restricted band.

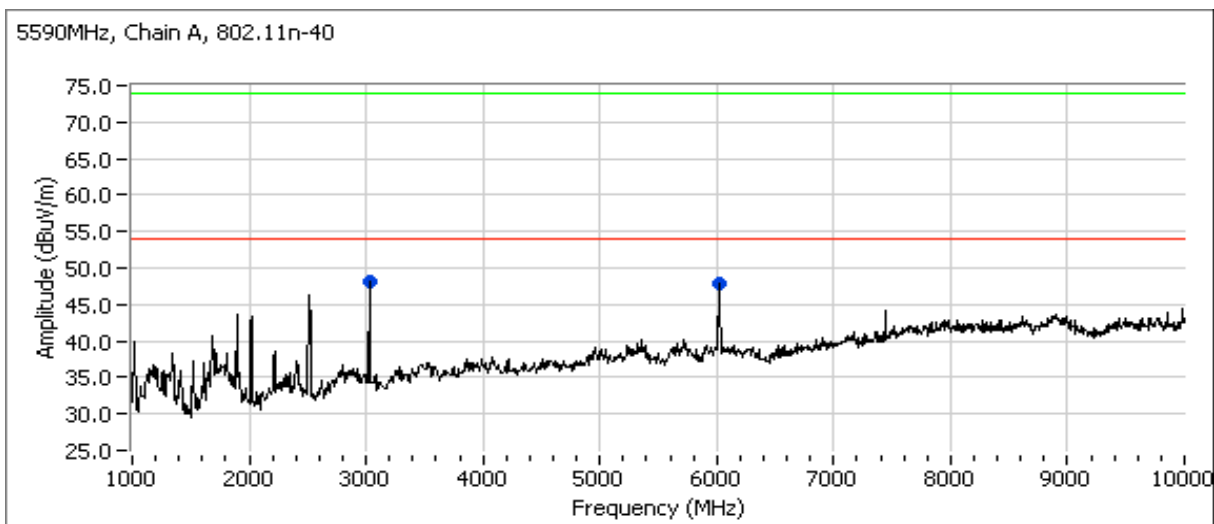

Client:	Intel	Job Number:	J70979
Model:	512an MMW	T-Log Number:	T71043
Contact:	Robert Paxman	Account Manager:	Briggs / Eriksen
Standard:	RSS 210 / FCC 15.407 UNII (Radiated)	Class:	N/A

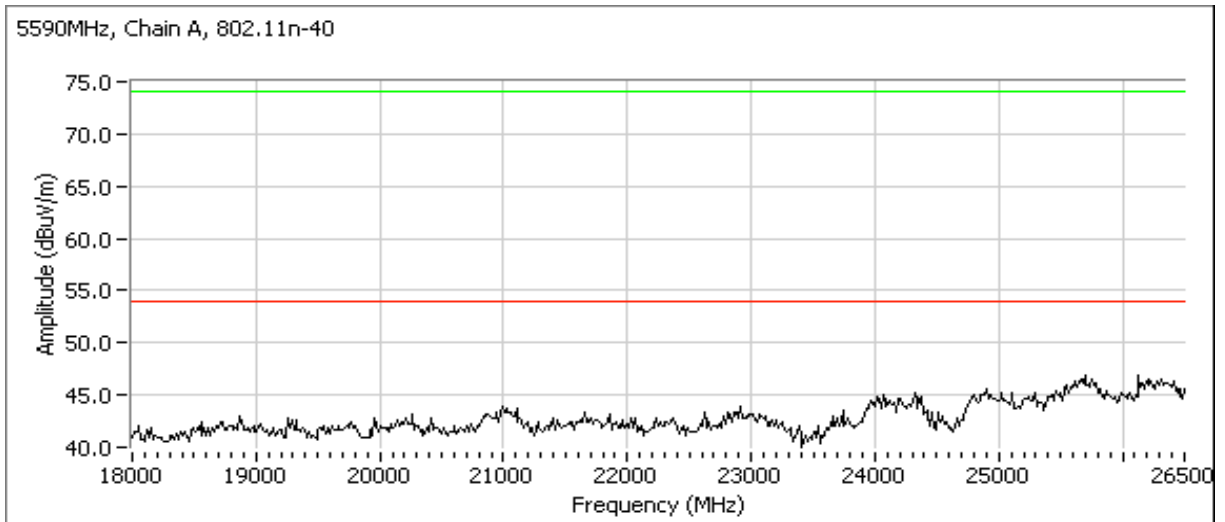
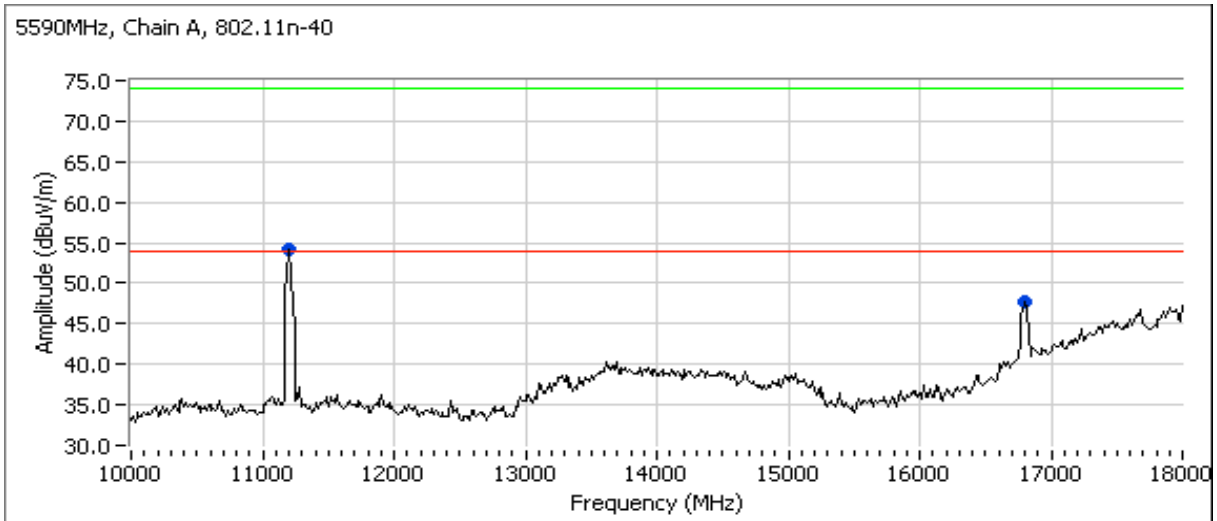

Client:	Intel	Job Number:	J70979
Model:	512an MMW	T-Log Number:	T71043
Contact:	Robert Paxman	Account Manager:	Briggs / Eriksen
Standard:	RSS 210 / FCC 15.407 UNII (Radiated)	Class:	N/A

Run #3c: High Channel @ 5670 MHz

Spurious Emissions

Frequency MHz	Level dB μ V/m	Pol v/h	15.209 / 15.247		Detector Pk/QP/Avg	Azimuth degrees	Height meters	Comments
			Limit	Margin				
2497.480	34.7	H	54.0	-19.3	AVG	147	1.0	
3000.370	48.6	V	68.3	-19.7	AVG	265	1.0	Note 2
6000.660	47.9	V	68.3	-20.4	AVG	271	1.9	Note 2
11340.390	44.1	V	54.0	-9.9	AVG	115	1.3	
38599.500	40.6	V	68.3	-27.7	AVG	298	1.9	Note 2 Noise floor
2497.480	54.2	H	74.0	-19.8	PK	147	1.0	
3000.370	52.3	V	88.3	-36.0	PK	265	1.0	Note 2
6000.660	52.8	V	88.3	-35.5	PK	271	1.9	Note 2
11340.390	55.0	V	74.0	-19.0	PK	115	1.3	
38599.500	52.7	V	88.3	-35.6	PK	298	1.9	Note 2 Noise floor

Note 1: For emissions in restricted bands, the limit of 15.209 was used. For all other emissions, the limit was set to -27dBm eirp (68.3dBuV/m average, 88.3dBuV/m peak)

Note 2: Signal is not in a restricted band.

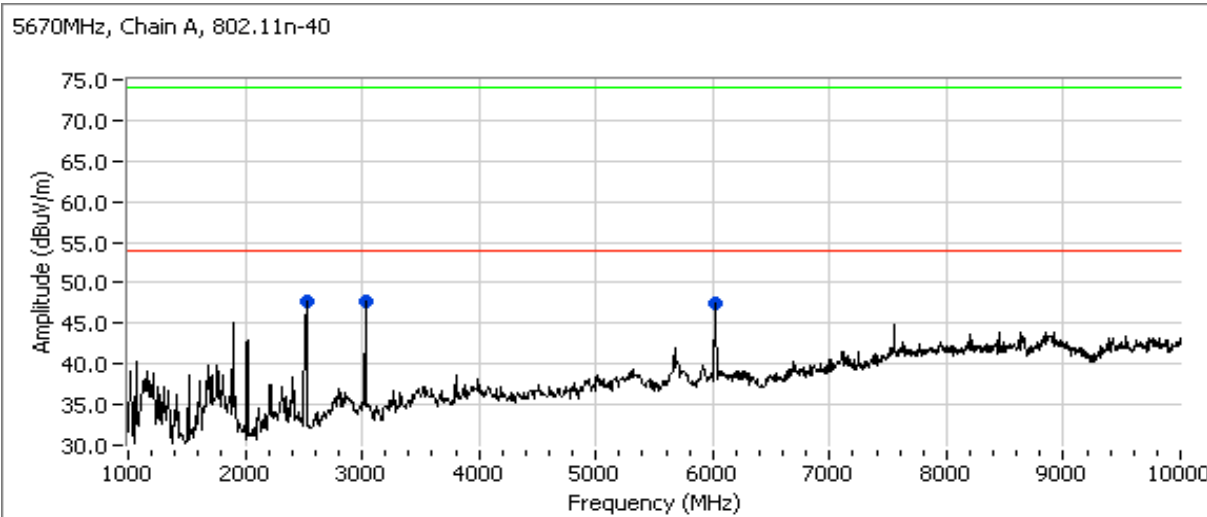

Client:	Intel	Job Number:	J70979
Model:	512an MMW	T-Log Number:	T71043
Contact:	Robert Paxman	Account Manager:	Briggs / Eriksen
Standard:	RSS 210 / FCC 15.407 UNII (Radiated)	Class:	N/A

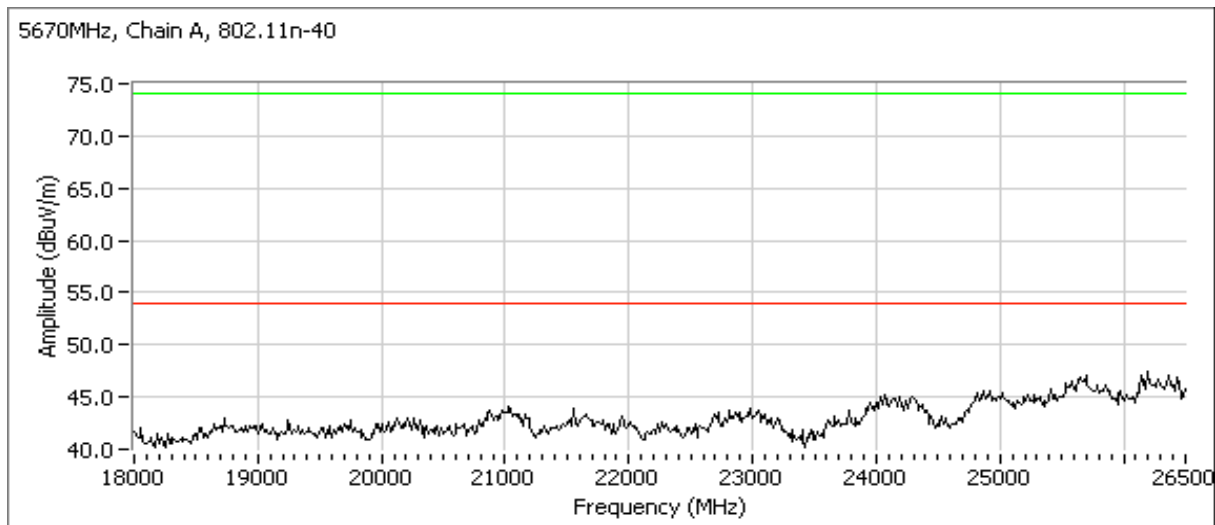
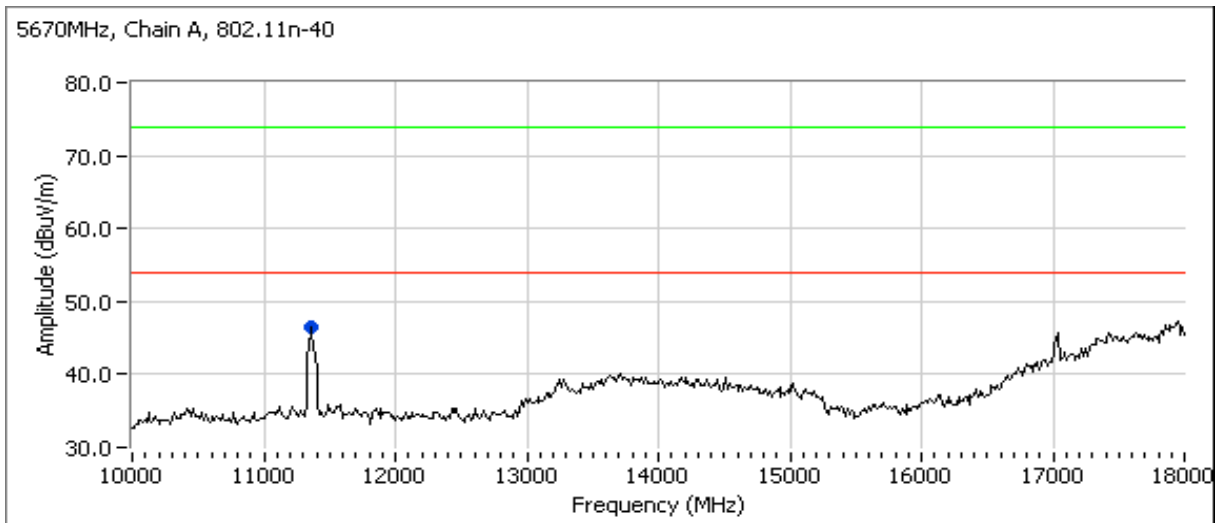



EMC Test Data

Client:	Intel	Job Number:	J70979
Model:	512an MMW	T-Log Number:	T71832
		Account Manager:	Briggs / Eriksen
Contact:	Robert Paxman		-
Emissions Standard(s):	RSS 210 / FCC 15.407 UNII (Radiated)	Class:	
Immunity Standard(s):	-	Environment:	-

EMC Test Data - NII Radiated, Universe Antenna

For The

Intel

Model

512an MMW

Date of Last Test: 6/7/2008

Client: Intel	Job Number: J70979
Model: 512an MMW	T-Log Number: T71832
	Account Manager: Briggs / Eriksen
Contact: Robert Paxman	
Standard: RSS 210 / FCC 15.407 UNII (Radiated)	Class: Enter on cover sheet

Radiated Emissions

Test Specific Details

Objective: The objective of this test session is to perform final qualification testing of the EUT with respect to the specification listed above.

Date of Test: 6/6/2008
 Test Engineer: Ben Jing
 Test Location: FT Chamber # 5

Config. Used: 1
 Config Change: None
 Host Unit Voltage 120V/60Hz

General Test Configuration

The EUT and all local support equipment were located on the turntable for radiated emissions testing. Remote support equipment was located approximately 30 meters from the test area with all I/O connections running on top of the groundplane.

The test distance and extrapolation factor (if applicable) are detailed under each run description.

Note, **preliminary** testing indicates that the emissions were maximized by orientation of the EUT and elevation of the measurement antenna. **Maximized** testing indicated that the emissions were maximized by orientation of the EUT, elevation of the measurement antenna, and manipulation of the EUT's interface cables.

Ambient Conditions: Temperature: 23 °C
 Rel. Humidity: 34 %

Summary of Results

Run #	Test Performed	Limit	Result	Margin
1 - Single Receiver chain	RE, 1000 - 18000 MHz, Maximized Emissions	RSS GEN	Pass	42.8 dBuV/m @ 5280.0 MHz (-11.2dB)
2 - All Receiver chains	RE, 1000 - 18000 MHz, Maximized Emissions	RSS GEN	Pass	40.9 dBuV/m @ 5279.9 MHz (-13.1dB)

Modifications Made During Testing

No modifications were made to the EUT during testing

Deviations From The Standard

No deviations were made from the requirements of the standard.

Client: Intel	Job Number: J70979
Model: 512an MMW	T-Log Number: T71832
	Account Manager: Briggs / Eriksen
Contact: Robert Paxman	
Standard: RSS 210 / FCC 15.407 UNII (Radiated)	Class: Enter on cover sheet

Run # 1: Maximized readings, 1000 - 18000 MHz, Single Receiver Active

Frequency Range	Test Distance	Limit Distance	Extrapolation Factor
1000 - 10000 MHz	3	3	0.0
10000 - 18000 MHz	1	3	-9.5

Receiver Tuned to 5200 MHz - Single chain active

Frequency MHz	Level dB μ V/m	Pol v/h	RSS GEN		Detector Pk/QP/Avg	Azimuth degrees	Height meters	Comments
			Limit	Margin				
2489.810	30.3	V	54.0	-23.7	AVG	63	1.3	
2489.810	49.6	V	74.0	-24.4	PK	63	1.3	
3000.100	36.5	V	54.0	-17.5	AVG	103	1.0	
3000.100	42.3	V	74.0	-31.7	PK	103	1.0	
5200.050	41.5	H	54.0	-12.5	AVG	257	1.3	
5200.050	45.7	H	74.0	-28.3	PK	257	1.3	
10399.960	36.5	V	54.0	-17.5	AVG	128	1.0	
10399.960	41.4	V	74.0	-32.6	PK	128	1.0	

Note 1: Above 1 GHz, the limit is for an average measurement. In addition, the peak value of any emission above 1 GHz, can not exceed the average limit by more than 20 dB.

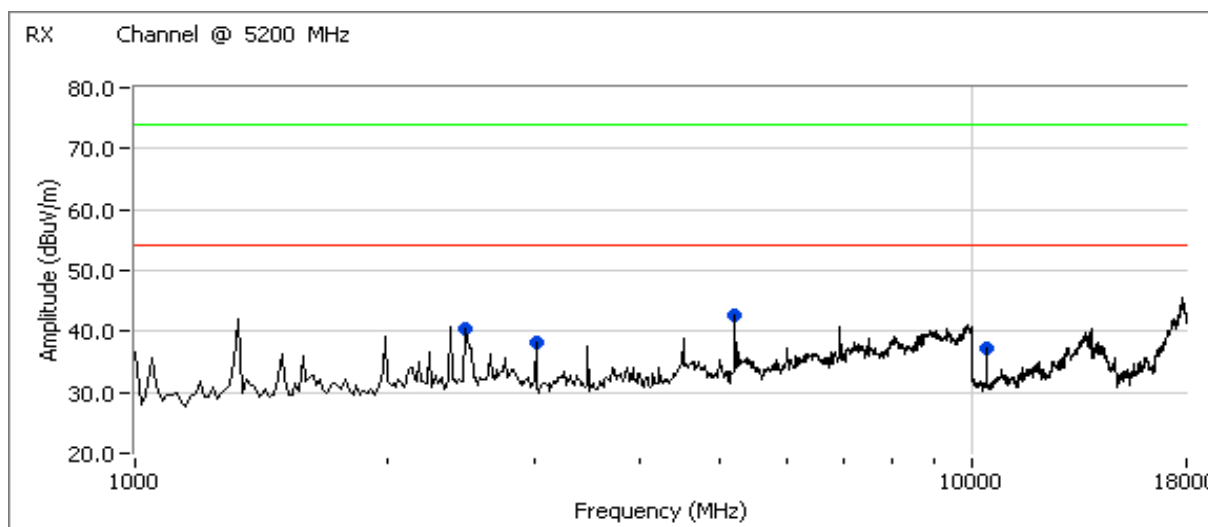

Client: Intel	Job Number: J70979
Model: 512an MMW	T-Log Number: T71832
	Account Manager: Briggs / Eriksen
Contact: Robert Paxman	
Standard: RSS 210 / FCC 15.407 UNII (Radiated)	Class: Enter on cover sheet

Receiver Tuned to 5280 MHz - Single chain active

Frequency MHz	Level dB μ V/m	Pol v/h	RSS GEN		Detector Pk/QP/Avg	Azimuth degrees	Height meters	Comments
			Limit	Margin				
2489.650	28.6	H	54.0	-25.4	AVG	82	1.3	
2489.650	46.0	H	74.0	-28.0	PK	82	1.3	
3520.010	40.3	V	54.0	-13.7	AVG	196	1.3	
3520.010	43.6	V	74.0	-30.4	PK	196	1.3	
5279.980	42.8	H	54.0	-11.2	AVG	260	1.3	
5279.980	46.6	H	74.0	-27.4	PK	260	1.3	
10559.990	37.1	V	54.0	-16.9	AVG	120	1.0	
10559.990	42.1	V	74.0	-31.9	PK	120	1.0	

Note 1: Above 1 GHz, the limit is for an average measurement. In addition, the peak value of any emission above 1 GHz, can not exceed the average limit by more than 20 dB.

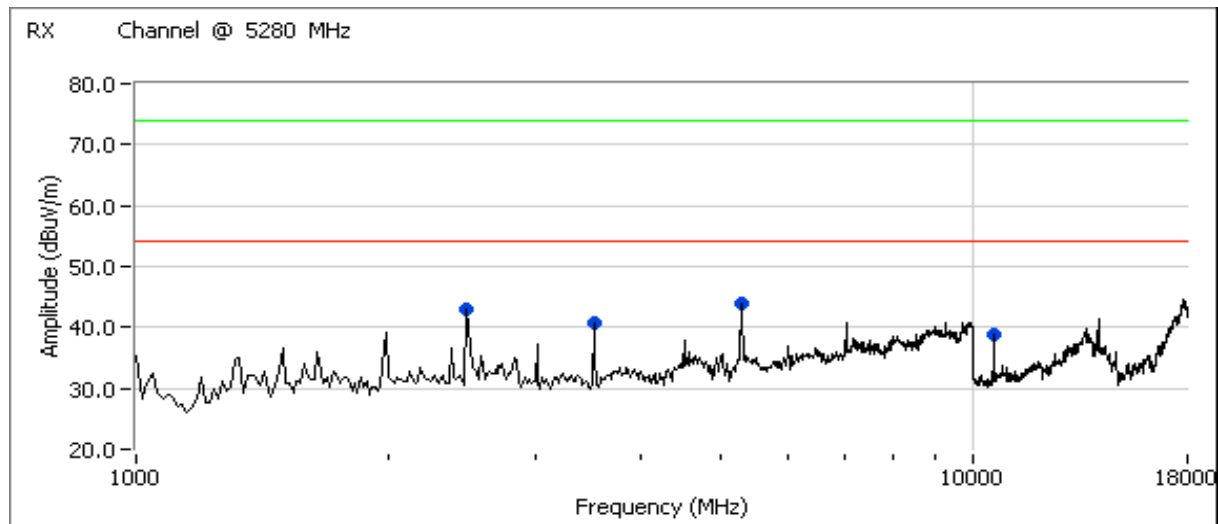

Client: Intel	Job Number: J70979
Model: 512an MMW	T-Log Number: T71832
Contact: Robert Paxman	Account Manager: Briggs / Eriksen
Standard: RSS 210 / FCC 15.407 UNII (Radiated)	Class: Enter on cover sheet

Receiver Tuned to 5600 MHz - Single chain active

Frequency MHz	Level dB μ V/m	Pol v/h	RSS GEN		Detector Pk/QP/Avg	Azimuth degrees	Height meters	Comments
			Limit	Margin				
2489.600	29.1	H	54.0	-24.9	AVG	84	1.3	
2489.600	47.7	H	74.0	-26.3	PK	84	1.3	
7466.750	38.3	V	54.0	-15.7	AVG	276	1.3	
7466.750	44.9	V	74.0	-29.1	PK	276	1.3	

Note 1: Above 1 GHz, the limit is for an average measurement. In addition, the peak value of any emission above 1 GHz, can not exceed the average limit by more than 20 dB.

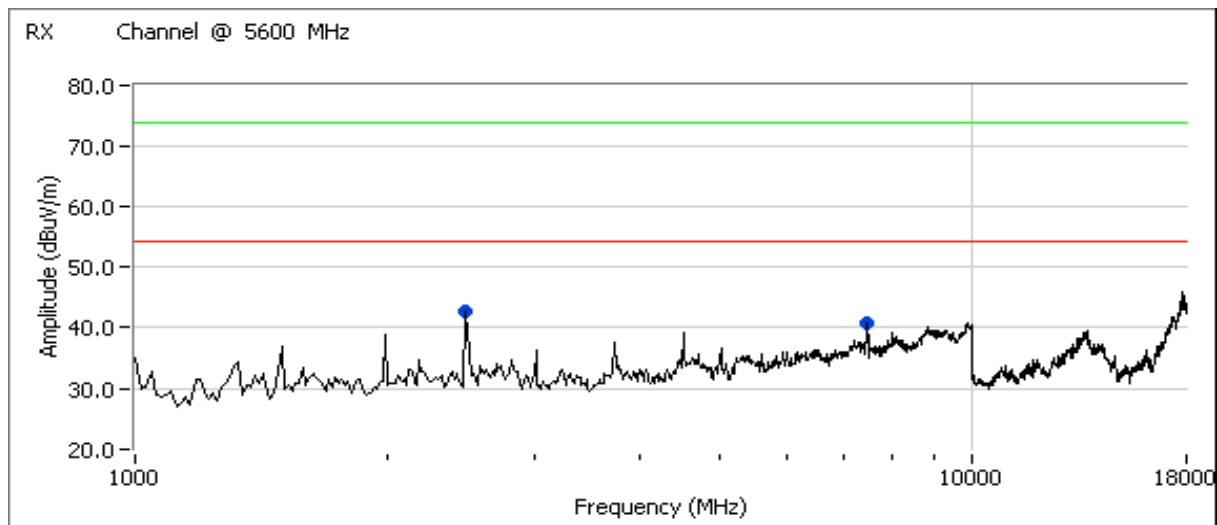

Client: Intel	Job Number: J70979
Model: 512an MMW	T-Log Number: T71832
	Account Manager: Briggs / Eriksen
Contact: Robert Paxman	
Standard: RSS 210 / FCC 15.407 UNII (Radiated)	Class: Enter on cover sheet

Run # 2: Maximized readings, 1000 - 18000 MHz, All Receivers Active

Frequency Range	Test Distance	Limit Distance	Extrapolation Factor
1000 - 10000 MHz	3	3	0.0
10000 - 18000 MHz	1	3	-9.5

Receiver Tuned to 5200 MHz - All chains active

Frequency MHz	Level dB μ V/m	Pol v/h	RSS GEN		Detector Pk/QP/Avg	Azimuth degrees	Height meters	Comments
			Limit	Margin				
2490.260	29.6	V	54.0	-24.4	AVG	67	1.3	
2490.260	49.5	V	74.0	-24.5	PK	67	1.3	
10399.970	38.3	V	54.0	-15.7	AVG	85	1.3	
10399.970	42.1	V	74.0	-31.9	PK	85	1.3	

Note 1: Above 1 GHz, the limit is for an average measurement. In addition, the peak value of any emission above 1 GHz, can not exceed the average limit by more than 20 dB.

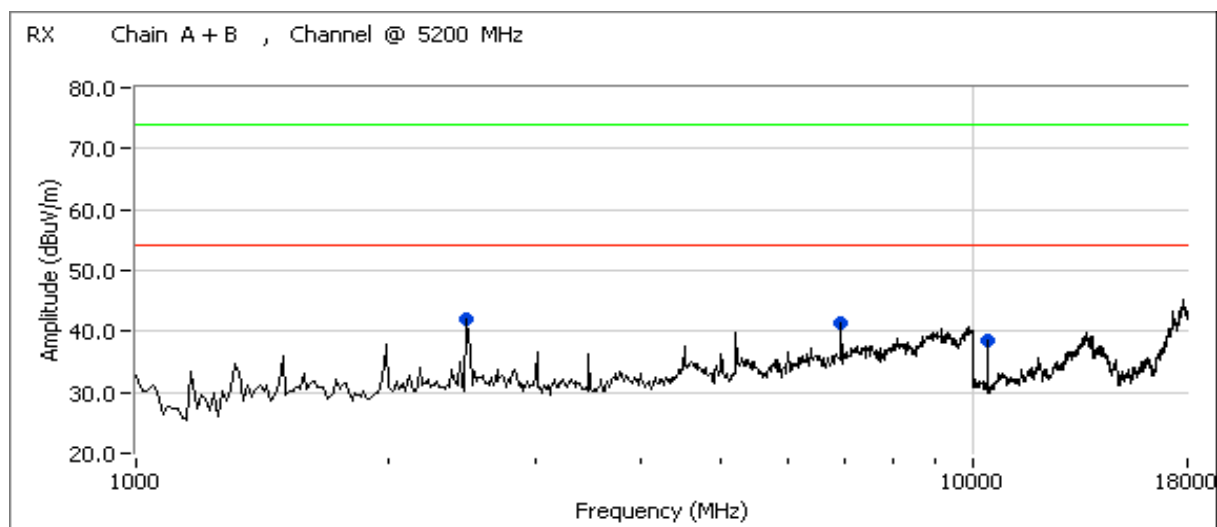

Client: Intel	Job Number: J70979
Model: 512an MMW	T-Log Number: T71832
	Account Manager: Briggs / Eriksen
Contact: Robert Paxman	
Standard: RSS 210 / FCC 15.407 UNII (Radiated)	Class: Enter on cover sheet

Receiver Tuned to 5280 MHz - All chains active

Frequency MHz	Level dB μ V/m	Pol v/h	RSS GEN		Detector Pk/QP/Avg	Azimuth degrees	Height meters	Comments
			Limit	Margin				
2489.960	28.6	V	54.0	-25.4	AVG	68	1.3	
2489.960	46.7	V	74.0	-27.3	PK	68	1.3	
3519.920	39.4	V	54.0	-14.6	AVG	198	1.3	
3519.920	43.2	V	74.0	-30.8	PK	198	1.3	
5279.890	40.9	V	54.0	-13.1	AVG	133	1.3	
5279.890	45.5	V	74.0	-28.5	PK	133	1.3	
10559.910	38.7	V	54.0	-15.3	AVG	110	1.0	
10559.910	43.0	V	74.0	-31.0	PK	110	1.0	

Note 1: Above 1 GHz, the limit is for an average measurement. In addition, the peak value of any emission above 1 GHz, can not exceed the average limit by more than 20 dB.

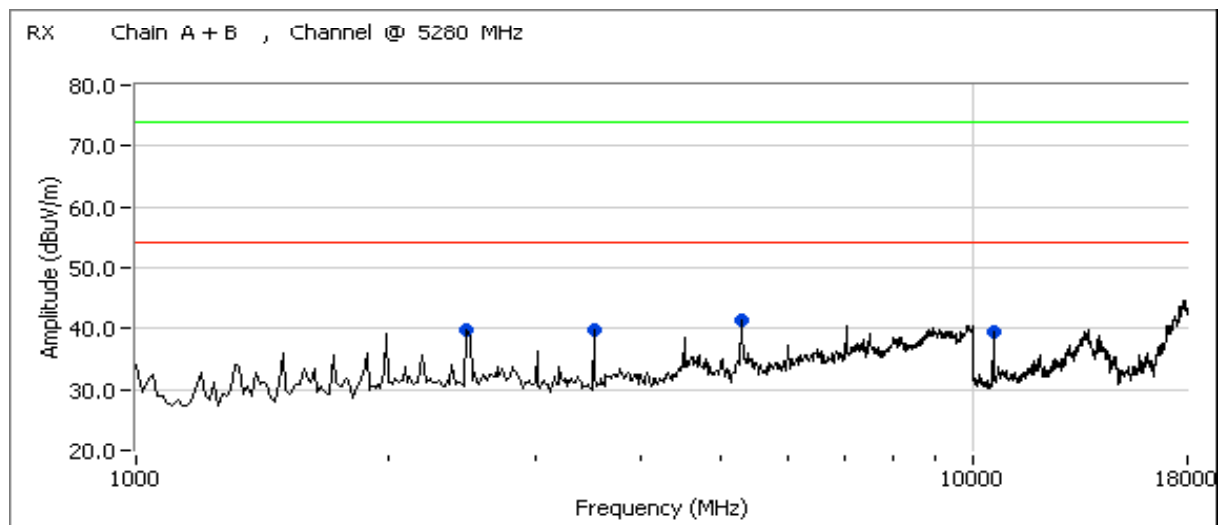

Client: Intel	Job Number: J70979
Model: 512an MMW	T-Log Number: T71832
Contact: Robert Paxman	Account Manager: Briggs / Eriksen
Standard: RSS 210 / FCC 15.407 UNII (Radiated)	Class: Enter on cover sheet

Receiver Tuned to 5600 MHz - All chains active

Frequency MHz	Level dB μ V/m	Pol v/h	RSS GEN		Detector Pk/QP/Avg	Azimuth degrees	Height meters	Comments
			Limit	Margin				
2490.740	27.3	V	54.0	-26.7	AVG	360	1.0	
2490.740	45.3	V	74.0	-28.7	PK	360	1.0	
3733.320	34.4	V	54.0	-19.6	AVG	276	1.6	
3733.320	40.9	V	74.0	-33.1	PK	276	1.6	
4500.000	37.0	V	54.0	-17.0	AVG	183	1.0	
4500.000	43.1	V	74.0	-30.9	PK	183	1.0	
7466.610	34.9	H	54.0	-19.1	AVG	303	1.6	
7466.610	43.7	H	74.0	-30.3	PK	303	1.6	

Note 1: Above 1 GHz, the limit is for an average measurement. In addition, the peak value of any emission above 1 GHz, can not exceed the average limit by more than 20 dB.

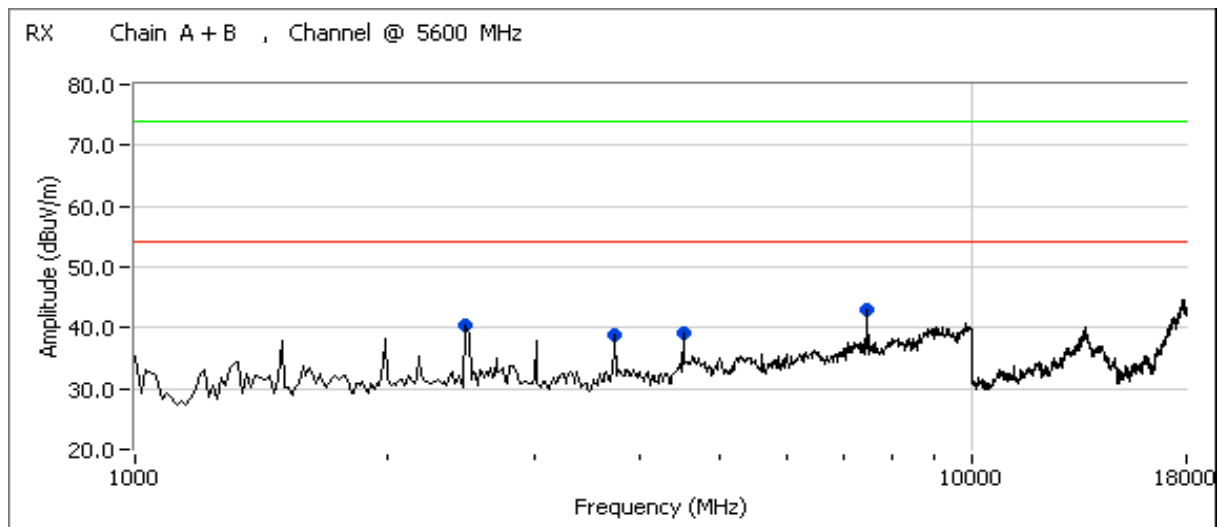

Client: Intel	Job Number: J70979
Model: 512an MMW	T-Log Number: T71832
	Account Manager: Briggs / Eriksen
Contact: Robert Paxman	
Standard: RSS 210 / FCC 15.407 UNII (Radiated)	Class: N/A

**RSS 210 and FCC 15.E (U-NII, 5150- 550/5250-5350/5460-5725MHz)
Radiated Spurious Emissions - Band Edge 802.11a Mode**

Test Specific Details

Objective: The objective of this test session is to perform final qualification testing of the EUT with respect to the specification listed above.

Date of Test: 5/31/2008	Config. Used: 1
Test Engineer: Ben Jing	Config Change: None
Test Location: FT Chamber # 5	Host Unit Voltage 120V/60Hz

General Test Configuration

The EUT and all local support equipment were located on the turntable for radiated spurious emissions testing. All remote support equipment was located approximately 30 meters from the EUT with all I/O connections running on top of the groundplane.

For radiated emissions testing the measurement antenna was located 3 meters from the EUT.

Ambient Conditions: Temperature: 22 °C
 Rel. Humidity: 36 %

Summary of Results

Run #	Mode	Channel	Power Setting	Measured Power	Test Performed	Limit	Result / Margin
1a	802.11a Chain A	5180MHz	GC = 29.0	AP = 15.8	Band Edge radiated field strength	FCC Part 15.209	52.6dBµV/m @ 5149.9MHz (-1.4dB)
1b	802.11a Chain A	5320MHz	GC = 24.5	AP = 16.6	Band Edge radiated field strength	FCC Part 15.209	51.1dBµV/m @ 5350.1MHz (-2.9dB)
1c	802.11a Chain A	5500MHz	GC = 27.0	AP = 19.1	Band Edge radiated field strength	FCC Part 15.209 / 15E	49.9dBµV/m @ 5459.7MHz (-4.1dB)

Note - with ethertronics antenna, band edge complied at AP=18.4dBm.

Modifications Made During Testing

No modifications were made to the EUT during testing

Deviations From The Standard

No deviations were made from the requirements of the standard.

Client: Intel	Job Number: J70979
Model: 512an MMW	T-Log Number: T71832
Contact: Robert Paxman	Account Manager: Briggs / Eriksen
Standard: RSS 210 / FCC 15.407 UNII (Radiated)	Class: N/A

Run #1: Radiated Spurious Emissions, Band Edges. Operating Mode: 802.11a - Chain A

Run #1a: Low Channel @ 5180 MHz (band edge at 5150 MHz)

Power Setting: 27.5 Average power: AP = 15.8 (for reference purposes)

Band Edge Signal Field Strength

Frequency MHz	Level dB μ V/m	Pol v/h	15.209 / 15.247		Detector PK/QP/Avg	Azimuth degrees	Height meters	Comments
			Limit	Margin				
5149.850	50.5	V	54.0	-3.5	AVG	149	1.0	GC = 27.5 , AP = 15.8 dBm
5149.890	52.6	H	54.0	-1.4	AVG	258	1.0	GC = 27.5 , AP = 15.8 dBm
5149.810	65.7	V	74.0	-8.3	PK	160	1.0	GC = 27.5 , AP = 15.8 dBm
5149.860	68.7	H	74.0	-5.3	PK	258	1.0	GC = 27.5 , AP = 15.8 dBm

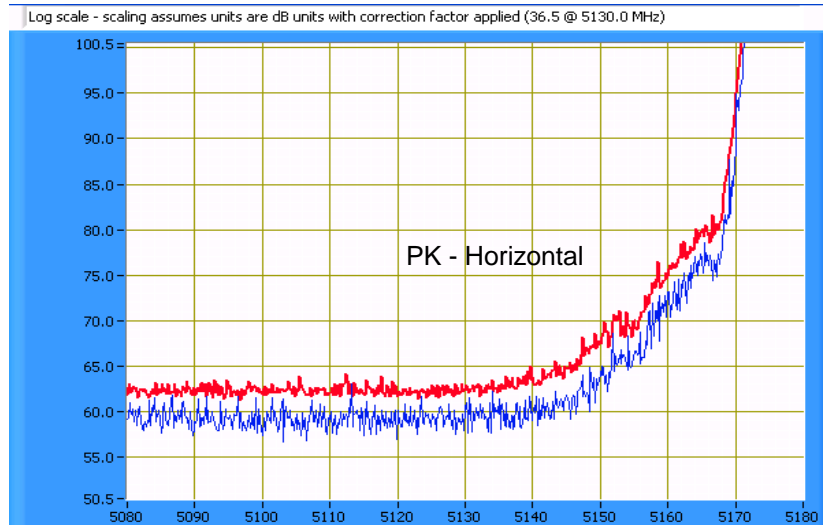
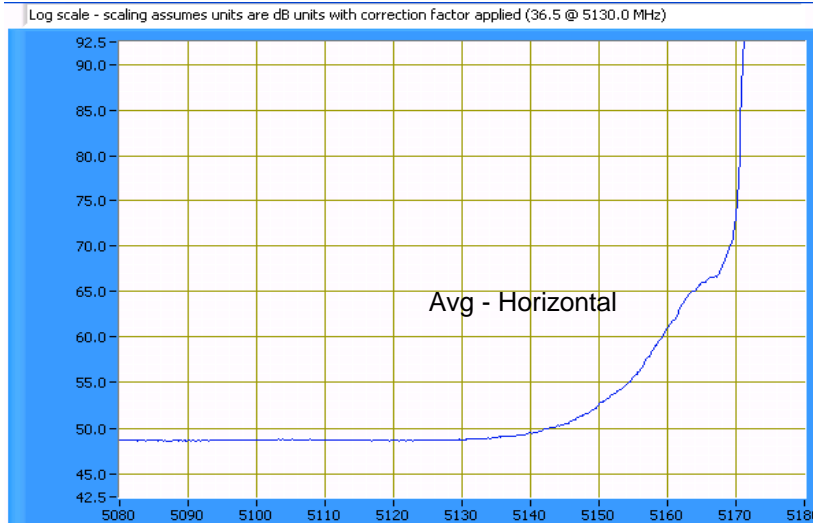

Client: Intel	Job Number: J70979
Model: 512an MMW	T-Log Number: T71832
Contact: Robert Paxman	Account Manager: Briggs / Eriksen
Standard: RSS 210 / FCC 15.407 UNII (Radiated)	Class: N/A

Run #1b: High Channel @ 5320 MHz (band edge at 5350 MHz)
 Power Setting: **24.5** Average power: AP = 16.6 (for reference purposes)

Fundamental Signal Field Strength: Peak and average values measured in 1 MHz, for reference only

Frequency	Level	Pol	15.209 / 15.247		Detector	Azimuth	Height	Comments
MHz	dB μ V/m	v/h	Limit	Margin	PK/QP/Avg	degrees	meters	
5321.170	98.6	V	-	-	AVG	154	1.0	RB = 1MHz, VB = 10Hz
5321.170	106.9	V	-	-	PK	154	1.0	RB = VB = 1MHz
5318.570	101.5	H	-	-	AVG	258	1.0	RB = 1MHz, VB = 10Hz
5318.570	110.1	H	-	-	PK	258	1.0	RB = VB = 1MHz

Band Edge Signal Field Strength

Frequency	Level	Pol	15.209 / 15.247		Detector	Azimuth	Height	Comments
MHz	dB μ V/m	v/h	Limit	Margin	PK/QP/Avg	degrees	meters	
5350.100	51.1	H	54.0	-2.9	AVG	257	1.0	
5350.280	65.4	H	74.0	-8.6	PK	256	1.5	
5350.230	63.1	V	74.0	-10.9	PK	158	1.5	
5350.100	49.6	V	54.0	-4.4	AVG	164	1.1	

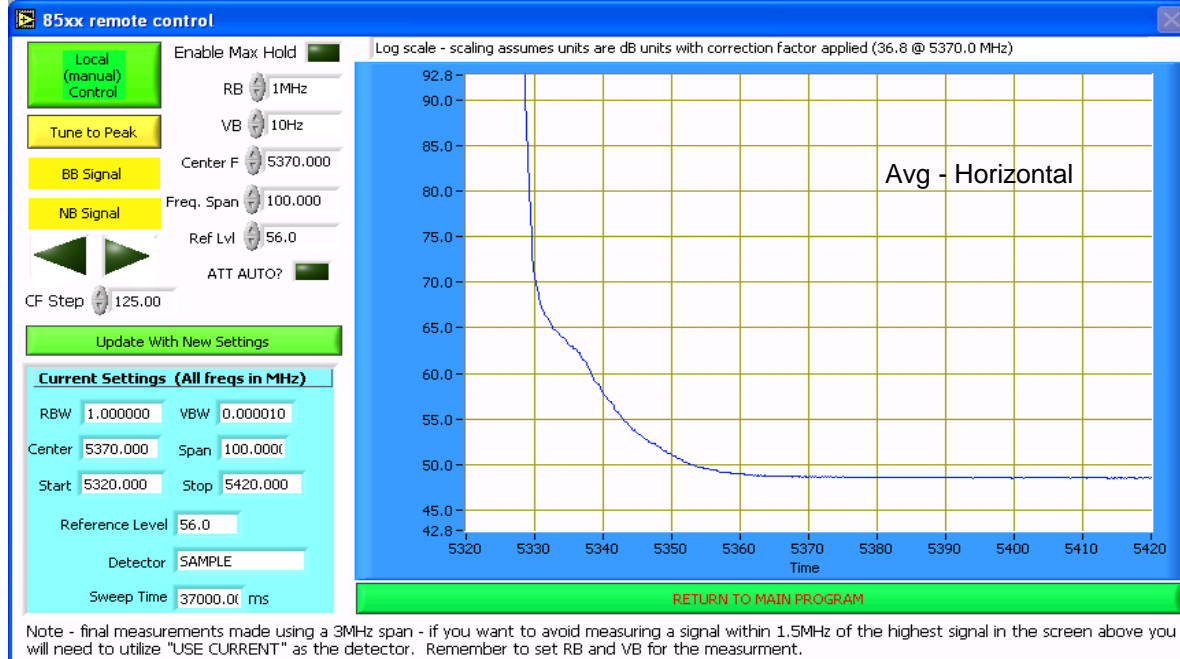

Client: Intel	Job Number: J70979
Model: 512an MMW	T-Log Number: T71832
	Account Manager: Briggs / Eriksen
Contact: Robert Paxman	
Standard: RSS 210 / FCC 15.407 UNII (Radiated)	Class: N/A

Run #1c: Low Channel @ 5500 MHz (restricted band edge at 5460 MHz, allocated band edge at 5470MHz)
 Power Setting: **27.0** Average power: AP = 19.1 (for reference purposes)

Fundamental Signal Field Strength: Peak and average values measured in 1 MHz, for reference only

Frequency	Level	Pol	15.209 / 15.247		Detector	Azimuth	Height	Comments
MHz	dB μ V/m	v/h	Limit	Margin	Pk/QP/Avg	degrees	meters	
5498.540	100.9	H	-	-	AVG	259	1.1	RB = 1MHz, VB = 10Hz
5498.540	109.3	H	-	-	PK	259	1.1	RB = VB = 1MHz

5460 - 5470 MHz, Limit is -27dBm eirp (68.3dBuV/m average, 88.3dBuV/m peak at 3m)

Frequency	Level	Pol	15.209 / 15.247		Detector	Azimuth	Height	Comments
MHz	dB μ V/m	v/h	Limit	Margin	Pk/QP/Avg	degrees	meters	
5469.880	54.5	H	68.3	-13.8	AVG	255	1.2	
5469.870	72.3	H	88.3	-16.0	PK	258	1.2	
5469.900	53.9	V	68.3	-14.4	AVG	166	1.2	
5469.780	70.6	V	88.3	-17.7	PK	166	1.1	

5460 Restricted Band Feld strength limit = 54dBuV/m avg, 74dBuV/m peak at 3m

Frequency	Level	Pol	15.209 / 15.247		Detector	Azimuth	Height	Comments
MHz	dB μ V/m	v/h	Limit	Margin	Pk/QP/Avg	degrees	meters	
5459.710	49.9	H	54.0	-4.1	AVG	253	1.2	
5459.740	66.5	H	74.0	-7.5	PK	253	1.2	
5459.700	49.7	V	54.0	-4.3	AVG	168	1.1	
5459.790	65.7	V	74.0	-8.3	PK	168	1.1	

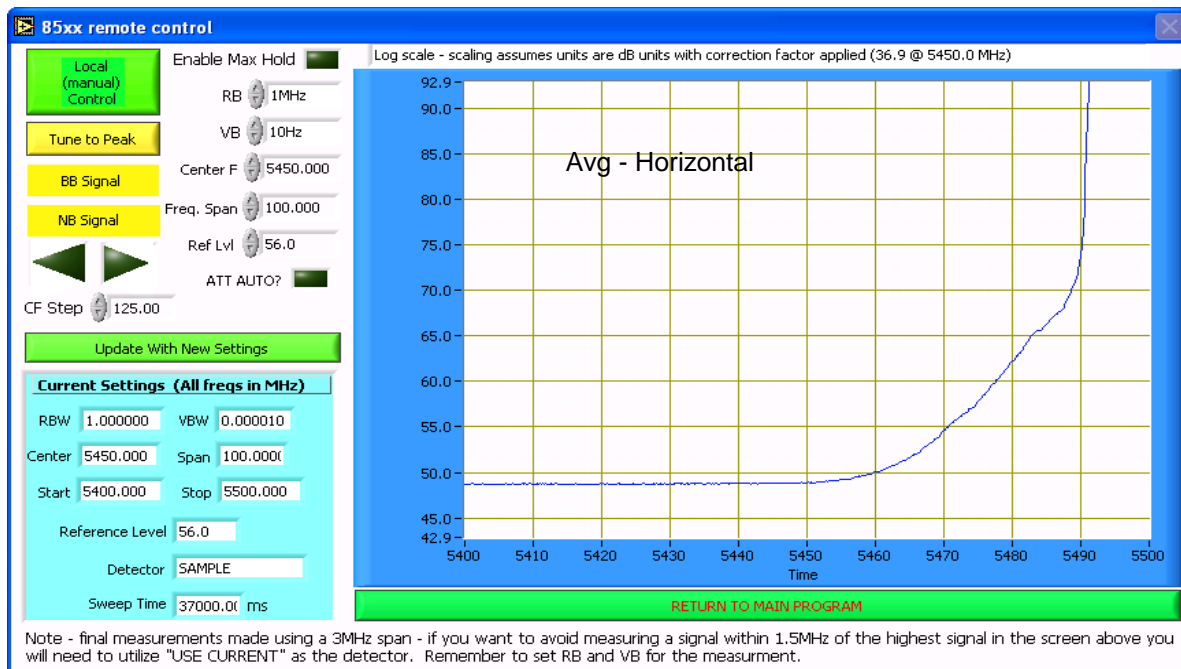

Client: Intel	Job Number: J70979
Model: 512an MMW	T-Log Number: T71832
	Account Manager: Briggs / Eriksen
Contact: Robert Paxman	
Standard: RSS 210 / FCC 15.407 UNII (Radiated)	Class: N/A

**RSS 210 and FCC 15.E (U-NII, 5150- 550/5250-5350/5460-5725MHz)
Radiated Spurious Emissions - Band Edge 802.11n 20MHz Mode**

Test Specific Details

Objective: The objective of this test session is to perform final qualification testing of the EUT with respect to the specification listed above.

Date of Test: 6/1/2008	Config. Used: 1
Test Engineer: Suhaila Khushzad	Config Change: None
Test Location: Chamber # 3	Host Unit Voltage Powered From Host System (3.3 V DC)

General Test Configuration

The EUT and all local support equipment were located on the turntable for radiated spurious emissions testing. All remote support equipment was located approximately 30 meters from the EUT with all I/O connections running on top of the groundplane.

For radiated emissions testing the measurement antenna was located 3 meters from the EUT.

Ambient Conditions: Temperature: 20 °C
 Rel. Humidity: 50 %

Summary of Results

Run #	Mode	Channel	Power Setting	Measured Power	Test Performed	Limit	Result / Margin
1a	802.11n20 Chain A	5180MHz	GC = 27	AP = 15.2	Band Edge radiated field strength	FCC Part 15.209	52.6dBµV/m @ 5149.9MHz (-1.4dB)
1b	802.11n20 Chain A	5320MHz	GC = 25.5	AP = 16	Band Edge radiated field strength	FCC Part 15.209	52.5dBµV/m @ 5350.0MHz (-1.5dB)
1c	802.11n20 Chain A	5500MHz	GC = 29	AP = 19.5	Band Edge radiated field strength	FCC Part 15.209 / 15E	52.9dBµV/m @ 5459.9MHz (-1.1dB)

Modifications Made During Testing

No modifications were made to the EUT during testing

Deviations From The Standard

No deviations were made from the requirements of the standard.

Client: Intel	Job Number: J70979
Model: 512an MMW	T-Log Number: T71832
	Account Manager: Briggs / Eriksen
Contact: Robert Paxman	
Standard: RSS 210 / FCC 15.407 UNII (Radiated)	Class: N/A

Run #1: Radiated Spurious Emissions, Band Edges. Operating Mode: 802.11n 20MHz - Chain A

Run #1a: Low Channel @ 5180 MHz (band edge at 5150 MHz)

Power Setting: 27 Average power: AP = 15.2 (for reference purposes)

Fundamental Signal Field Strength: Peak and average values measured in 1 MHz, for reference only

Frequency MHz	Level dB μ V/m	Pol v/h	15.209 / 15.247		Detector Pk/QP/Avg	Azimuth degrees	Height meters	Comments
			Limit	Margin				
5181.150	99.5	H	-	-	AVG	230	1.0	RB = 1MHz, VB = 10Hz
5181.150	108.0	H	-	-	PK	230	1.0	RB = VB = 1MHz
5178.540	97.0	V	-	-	AVG	187	2.2	RB = 1MHz, VB = 10Hz
5178.540	105.3	V	-	-	PK	187	2.2	RB = VB = 1MHz

Band Edge Signal Field Strength

Frequency MHz	Level dB μ V/m	Pol v/h	15.209 / 15.247		Detector Pk/QP/Avg	Azimuth degrees	Height meters	Comments
			Limit	Margin				
5149.860	52.6	H	54.0	-1.4	AVG	230	1.0	Note 1
5149.940	66.9	H	74.0	-7.1	PK	230	1.0	Note 1
5149.810	65.2	V	74.0	-8.8	PK	187	2.2	Note 1
5149.770	50.6	V	54.0	-3.4	AVG	187	2.2	Note 1

Note 1: Target GC = 28.5 and AP=16.5 dBm, passing GC=27 and AP=15.2 dBm.

Client: Intel	Job Number: J70979
Model: 512an MMW	T-Log Number: T71832
Contact: Robert Paxman	Account Manager: Briggs / Eriksen
Standard: RSS 210 / FCC 15.407 UNII (Radiated)	Class: N/A

Run #1: Radiated Spurious Emissions, Band Edges. Operating Mode: 802.11n 20MHz - Chain A

Run #1a: Low Channel @ 5180 MHz (band edge at 5150 MHz)

Power Setting: 27

Average power: AP = 15.2 (for reference purposes)

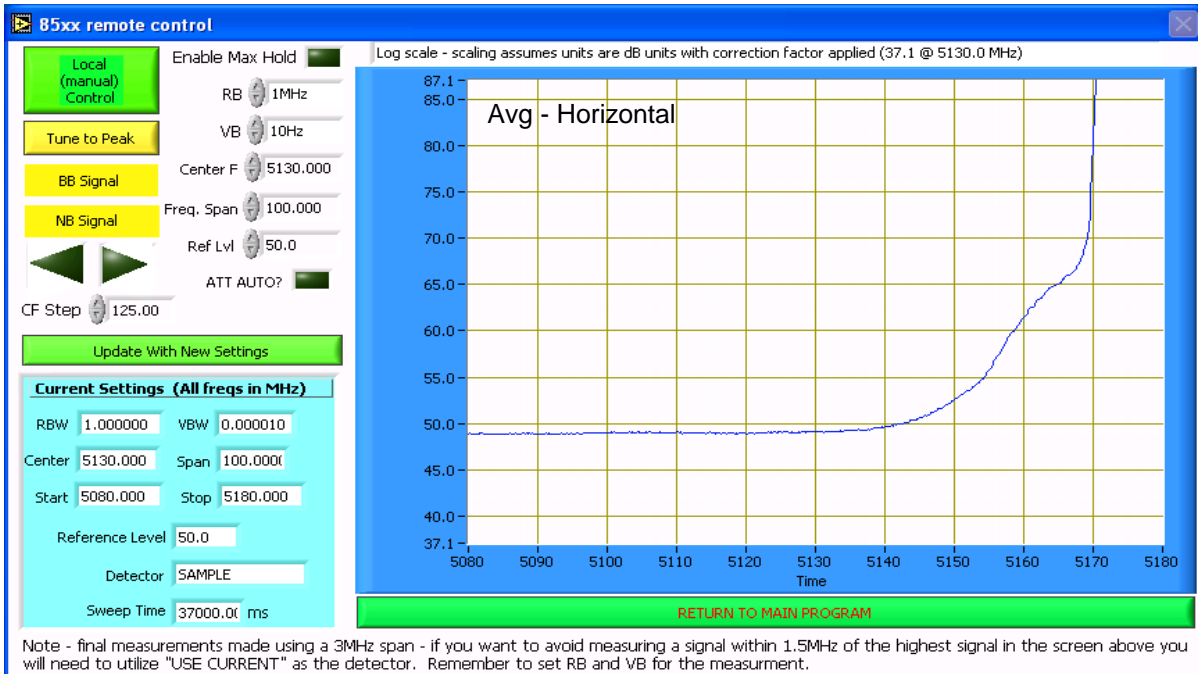
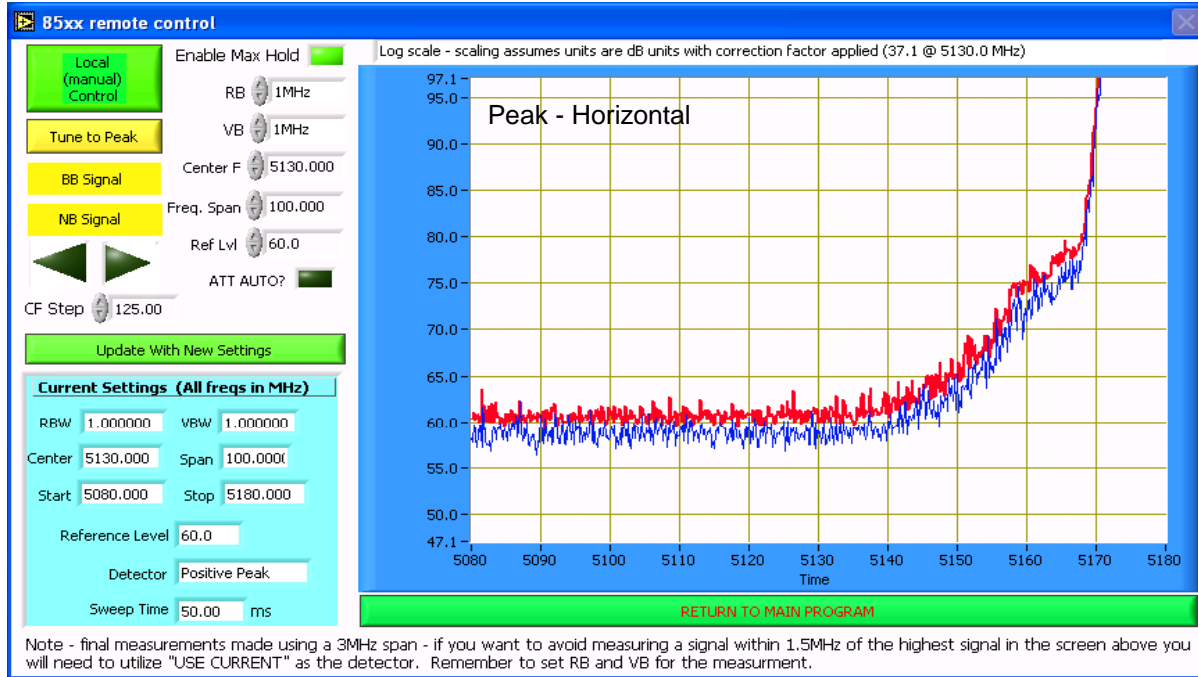

Client: Intel	Job Number: J70979
Model: 512an MMW	T-Log Number: T71832
Contact: Robert Paxman	Account Manager: Briggs / Eriksen
Standard: RSS 210 / FCC 15.407 UNII (Radiated)	Class: N/A

Run #1: Radiated Spurious Emissions, Band Edges. Operating Mode: 802.11n 20MHz - Chain A

Run #1b: High Channel @ 5320 MHz (band edge at 5350 MHz)

Power Setting: 25.5

Average power: AP = 16 (for reference purposes)

Fundamental Signal Field Strength: Peak and average values measured in 1 MHz, for reference only

Frequency MHz	Level dB μ V/m	Pol v/h	15.209 / 15.247		Detector Pk/QP/Avg	Azimuth degrees	Height meters	Comments
			Limit	Margin				
5327.170	101.2	H	-	-	AVG	254	1.2	RB = 1MHz, VB = 10Hz
5327.170	109.3	H	-	-	PK	254	1.2	RB = VB = 1MHz
5314.420	98.9	V	-	-	AVG	197	1.9	RB = 1MHz, VB = 10Hz
5314.420	107.5	V	-	-	PK	197	1.9	RB = VB = 1MHz

Band Edge Signal Field Strength

Frequency MHz	Level dB μ V/m	Pol v/h	15.209 / 15.247		Detector Pk/QP/Avg	Azimuth degrees	Height meters	Comments
			Limit	Margin				
5350.000	52.5	H	54.0	-1.5	AVG	254	1.2	Note 2
5350.040	67.2	H	74.0	-6.8	PK	254	1.2	Note 2
5351.320	64.5	V	74.0	-9.5	PK	197	1.8	Note 2
5350.000	51.0	V	54.0	-3.0	AVG	197	1.9	Note 2

Note 2: Target GC = 25, passing GC=25.5 and AP=16 dBm.

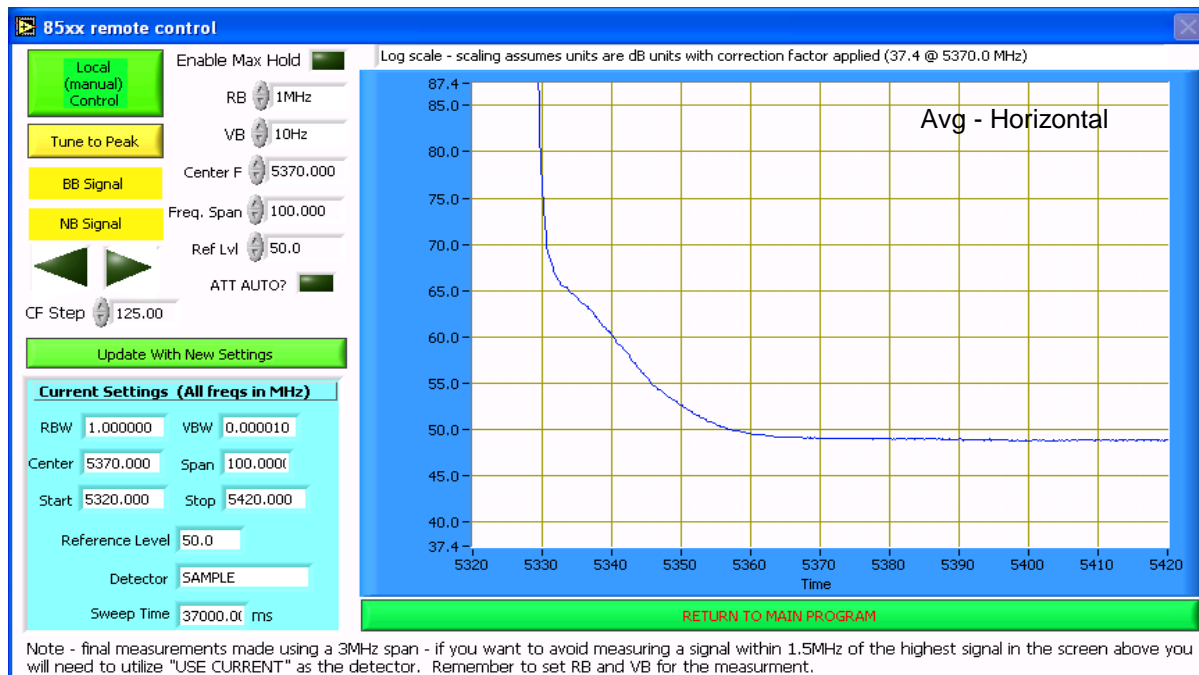

Client: Intel	Job Number: J70979
Model: 512an MMW	T-Log Number: T71832
Contact: Robert Paxman	Account Manager: Briggs / Eriksen
Standard: RSS 210 / FCC 15.407 UNII (Radiated)	Class: N/A

Run #1: Radiated Spurious Emissions, Band Edges. Operating Mode: 802.11n 20MHz - Chain A
 Run #1c: Low Channel @ 5500 MHz (restricted band edge at 5460 MHz, allocated band edge at 5470MHz)
 Power Setting: 29 Average power: AP = 19.5 (for reference purposes)

Fundamental Signal Field Strength: Peak and average values measured in 1 MHz, for reference only

Frequency	Level	Pol	15.209 / 15.247		Detector	Azimuth	Height	Comments
MHz	dB μ V/m	v/h	Limit	Margin	PK/QP/Avg	degrees	meters	
5494.670	102.2	H	-	-	AVG	256	1.3	RB = 1MHz, VB = 10Hz
5494.670	110.9	H	-	-	PK	256	1.3	RB = VB = 1MHz

5460 - 5470 MHz, Limit is -27dBm eirp (68.3dBuV/m average, 88.3dBuV/m peak at 3m)

Frequency	Level	Pol	15.209 / 15.247		Detector	Azimuth	Height	Comments
MHz	dB μ V/m	v/h	Limit	Margin	PK/QP/Avg	degrees	meters	
5459.920	52.9	H	54.0	-1.1	AVG	256	1.3	
5457.290	69.9	H	74.0	-4.1	PK	256	1.3	
5457.060	66.7	V	74.0	-7.3	PK	143	1.0	
5459.730	51.3	V	54.0	-2.7	AVG	143	1.0	

5460 Restricted Band Feld strength limit = 54dBuV/m avg, 74dBuV/m peak at 3m

Frequency	Level	Pol	15.209 / 15.247		Detector	Azimuth	Height	Comments
MHz	dB μ V/m	v/h	Limit	Margin	PK/QP/Avg	degrees	meters	
5469.980	57.8	H	68.3	-10.5	AVG	256	1.3	
5467.250	73.6	H	88.3	-14.7	PK	256	1.3	

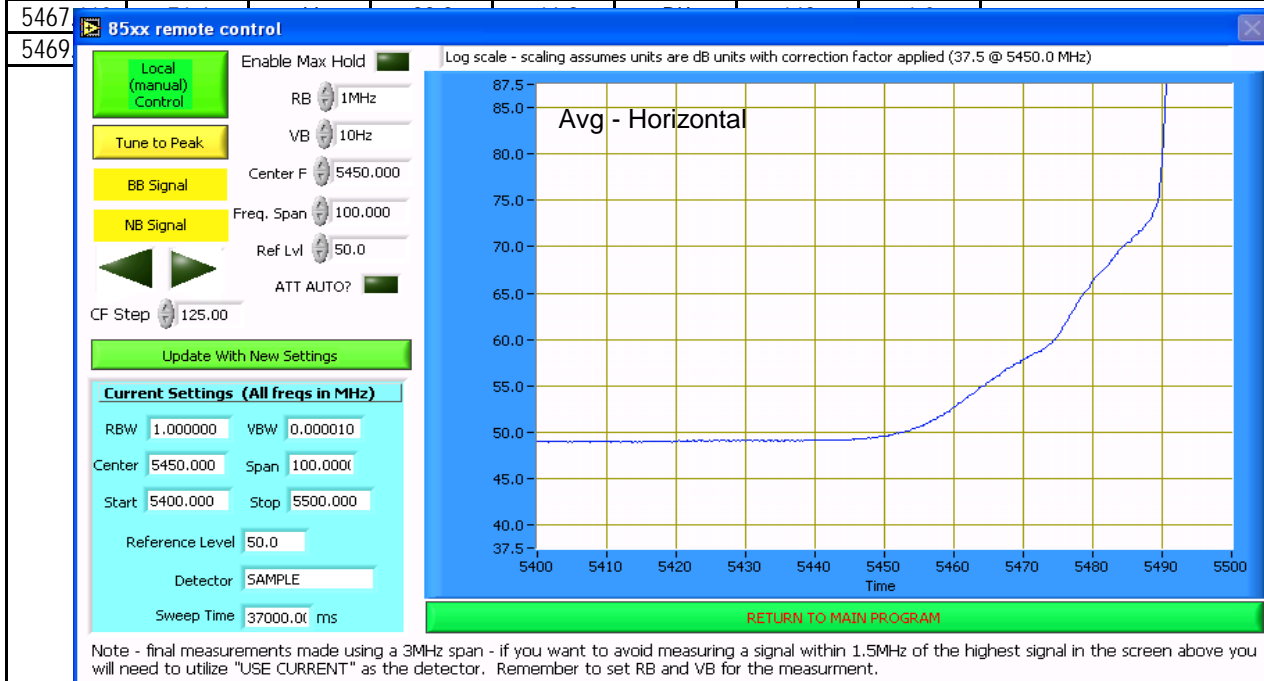

Client: Intel	Job Number: J70979
Model: 512an MMW	T-Log Number: T71832
	Account Manager: Briggs / Eriksen
Contact: Robert Paxman	
Standard: RSS 210 / FCC 15.407 UNII (Radiated)	Class: N/A

Run #1: Radiated Spurious Emissions, Band Edges. Operating Mode: 802.11n 40MHz - Chain A
 Run #1a: Low Channel @ 5190 MHz (band edge at 5150 MHz)

Date of Test: 6/5/2008
 Test Engineer: Ben Jing
 Test Location: Chamber # 5
 Power Setting: 22.0 Average power: 10.9 dBm (for reference purposes)

Fundamental Signal Field Strength: Peak and average values measured in 1 MHz, for reference only

Frequency MHz	Level dB μ V/m	Pol v/h	15.209 / 15.247		Detector Pk/QP/Avg	Azimuth degrees	Height meters	Comments
			Limit	Margin				
5191.400	88.3	V	-	-	AVG	138	1.0	RB = 1MHz, VB = 10Hz
5191.400	96.4	V	-	-	PK	138	1.0	RB = VB = 1MHz
5191.340	90.6	H	-	-	AVG	274	1.0	RB = 1MHz, VB = 10Hz
5191.340	98.9	H	-	-	PK	274	1.0	RB = VB = 1MHz

Band Edge Signal Field Strength

Frequency MHz	Level dB μ V/m	Pol v/h	15.209 / 15.247		Detector Pk/QP/Avg	Azimuth degrees	Height meters	Comments
			Limit	Margin				
5149.700	50.5	V	54.0	-3.5	AVG	141	1.0	GC = 22.0 , AP = 10.9 dBm
5149.870	52.3	H	54.0	-1.7	AVG	271	1.0	GC = 22.0 , AP = 10.9 dBm
5149.770	65.9	H	74.0	-8.1	PK	271	1.0	GC = 22.0 , AP = 10.9 dBm
5149.800	63.2	V	74.0	-10.8	PK	120	1.0	GC = 22.0 , AP = 10.9 dBm

Note 1: Target GC = 26 , Passing GC=22 and AP= 10.9 dBm.

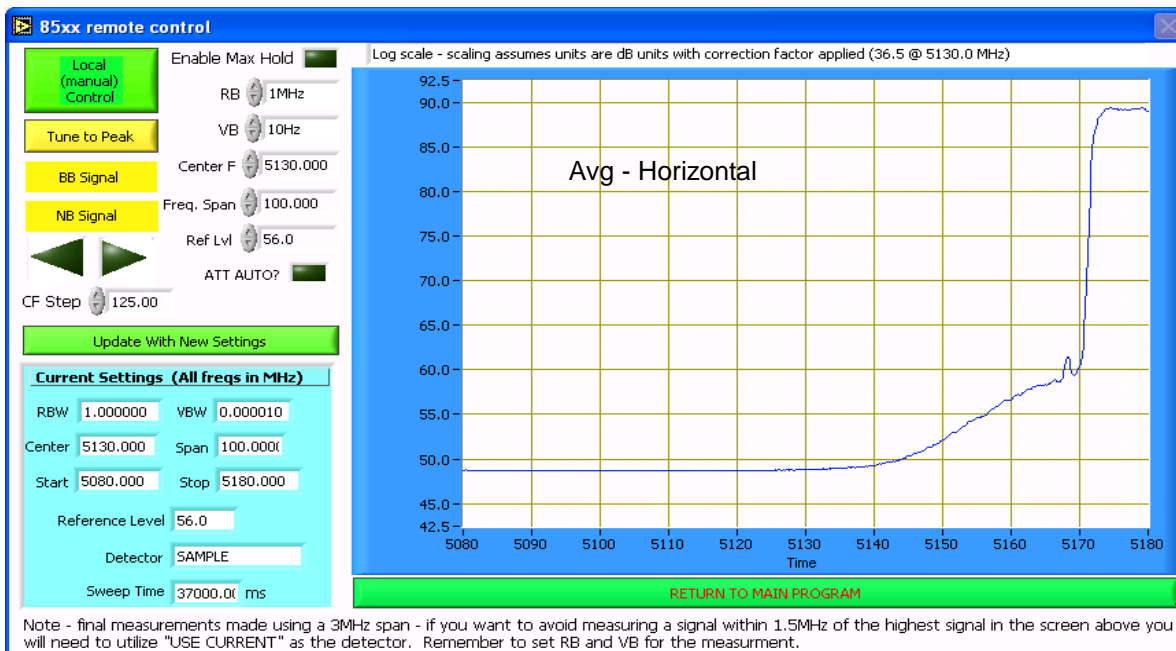

Note - final measurements made using a 3MHz span - if you want to avoid measuring a signal within 1.5MHz of the highest signal in the screen above you will need to utilize "USE CURRENT" as the detector. Remember to set RB and VB for the measurement.

Client: Intel	Job Number: J70979
Model: 512an MMW	T-Log Number: T71832
	Account Manager: Briggs / Eriksen
Contact: Robert Paxman	
Standard: RSS 210 / FCC 15.407 UNII (Radiated)	Class: N/A

Run #1b: High Channel @ 5310 MHz (band edge at 5350 MHz)

Date of Test: 6/2/2008
 Test Engineer: Ben Jing and Jack Plotner
 Test Location: Chamber # 5

Power Setting: 19.5 Average power: 11.4 dBm (for reference purposes)

Fundamental Signal Field Strength: Peak and average values measured in 1 MHz, for reference only

Frequency MHz	Level dB μ V/m	Pol v/h	15.209 / 15.247		Detector Pk/QP/Avg	Azimuth degrees	Height meters	Comments
			Limit	Margin				
5308.610	87.7	V	-	-	AVG	131	1.0	RB = 1MHz, VB = 10Hz
5308.610	96.0	V	-	-	PK	131	1.0	RB = VB = 1MHz
5308.690	89.4	H	-	-	AVG	269	1.0	RB = 1MHz, VB = 10Hz
5308.690	97.8	H	-	-	PK	269	1.0	RB = VB = 1MHz

Band Edge Signal Field Strength

Frequency MHz	Level dB μ V/m	Pol v/h	15.209 / 15.247		Detector Pk/QP/Avg	Azimuth degrees	Height meters	Comments
			Limit	Margin				
5350.100	52.1	H	54.0	-1.9	AVG	274	1.0	GC = 19.5 , AP = 11.4 dBm
5350.280	66.5	H	74.0	-7.5	PK	274	1.0	GC = 19.5 , AP = 11.4 dBm
5350.280	65.6	V	74.0	-8.4	PK	171	1.0	GC = 19.5 , AP = 11.4 dBm
5350.100	51.9	V	54.0	-2.1	AVG	172	1.0	GC = 19.5 , AP = 11.4 dBm

Note 1: Target GC = 24 and AP = 15.7 dBm , Passing GC= 19.5 and AP= 11.4 dBm.

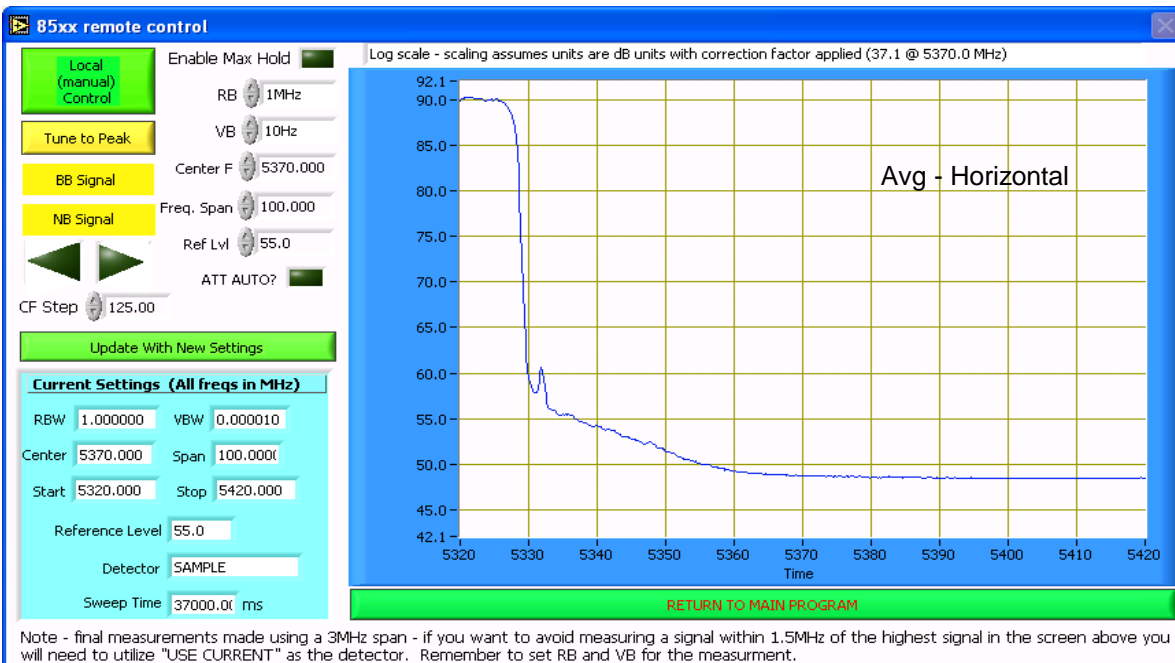

Client: Intel	Job Number: J70979
Model: 512an MMW	T-Log Number: T71832
Contact: Robert Paxman	Account Manager: Briggs / Eriksen
Standard: RSS 210 / FCC 15.407 UNII (Radiated)	Class: N/A

Date of Test: 6/2/2008
 Test Engineer: Ben Jing
 Test Location: Chamber # 5

Run #1c: Low Channel @ 5510 MHz (restricted band edge at 5460 MHz, allocated band edge at 5470MHz)

Power Setting: 23.5 Average power: 16.2 dBm (for reference purposes)

Fundamental Signal Field Strength: Peak and average values measured in 1 MHz, for reference only

Frequency	Level	Pol	15.209 / 15.247		Detector	Azimuth	Height	Comments
MHz	dB μ V/m	v/h	Limit	Margin	PK/QP/Avg	degrees	meters	
5511.330	93.7	V	-	-	AVG	176	1.0	RB = 1MHz, VB = 10Hz
5511.330	102.1	V	-	-	PK	176	1.0	RB = VB = 1MHz

5460 - 5470 MHz, Limit is -27dBm eirp (68.3dBuV/m average, 88.3dBuV/m peak at 3m)

Frequency	Level	Pol	15.209 / 15.247		Detector	Azimuth	Height	Comments
MHz	dB μ V/m	v/h	Limit	Margin	PK/QP/Avg	degrees	meters	
5459.890	51.8	H	68.3	-16.5	AVG	287	1.0	
5459.890	64.5	H	88.3	-23.8	PK	287	1.0	
5459.730	53.6	V	68.3	-14.7	AVG	172	1.0	
5459.730	66.0	V	88.3	-22.3	PK	172	1.0	

5460 Restricted Band Feld strength limit = 54dBuV/m avg, 74dBuV/m peak at 3m

Frequency	Level	Pol	15.209 / 15.247		Detector	Azimuth	Height	Comments
MHz	dB μ V/m	v/h	Limit	Margin	PK/QP/Avg	degrees	meters	
5459.760	66.4	V	74.0	-7.6	PK	176	1.0	
5459.830	52.7	V	54.0	-1.3	AVG	170	1.0	
5459.890	65.4	H	74.0	-8.6	PK	275	1.0	
5459.720	51.9	H	54.0	-2.1	AVG	269	1.0	

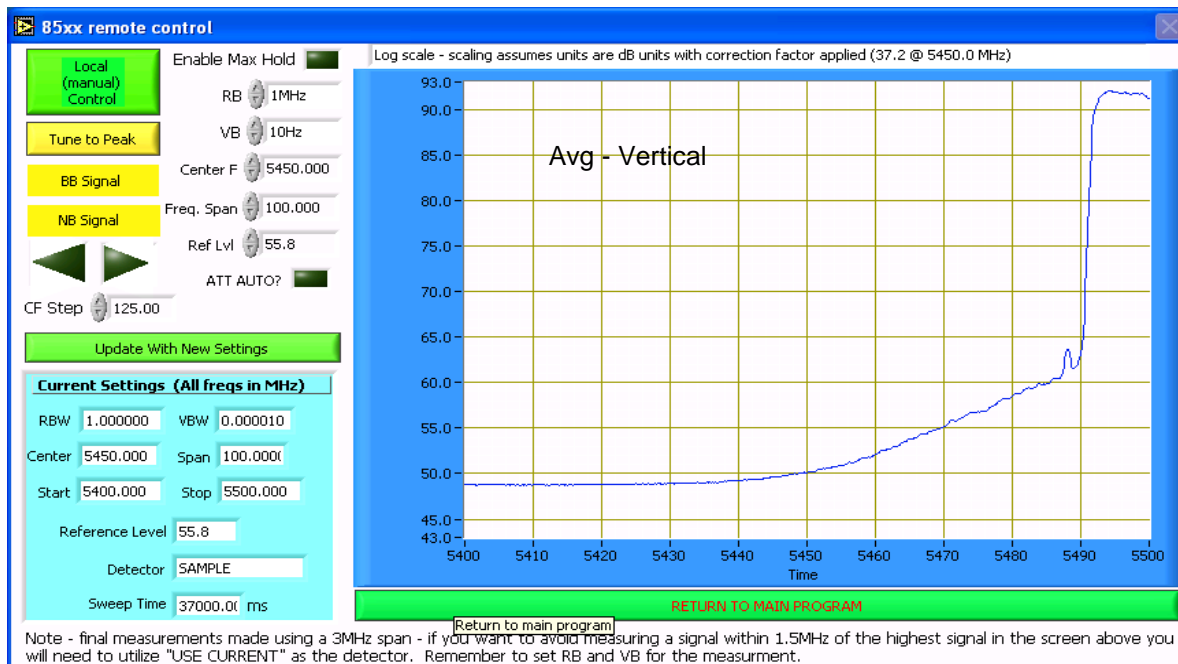

Client:	Intel	Job Number:	J70979
Model:	512an MMW	T-Log Number:	T71832
		Account Manager:	Briggs / Eriksen
Contact:	Robert Paxman		
Standard:	RSS 210 / FCC 15.407 UNII (Radiated)	Class:	N/A

**RSS 210 and FCC 15.247 (UNII, 2400 - 2483.5 MHz)
Radiated Spurious Emissions, 1 - 40GHz 802.11a Mode**

Test Specific Details

Objective: The objective of this test session is to perform final qualification testing of the EUT with respect to the specification listed above.

General Test Configuration

The EUT and all local support equipment were located on the turntable for radiated spurious emissions testing. All remote support equipment was located approximately 30 meters from the EUT with all I/O connections running on top of the groundplane.

For radiated emissions testing the measurement antenna was located 3 meters from the EUT.

Ambient Conditions: Temperature: 23 °C
 Rel. Humidity: 34 %

Modifications Made During Testing

No modifications were made to the EUT during testing

Deviations From The Standard

No deviations were made from the requirements of the standard.

Summary of Results

Run #	Mode	Channel	Power Setting	Measured Power	Test Performed	Limit	Result / Margin
1a	802.11a Chain A	5180	GC = 27.5	AP = 16.5	Radiated Emissions, 1 - 26 GHz	FCC Part 15.209 / 15.407	58.6 dBuV/m @ 6906.6 MHz (-9.7dB)
1b	802.11a Chain A	5200	GC = 27.5	AP = 16.6	Radiated Emissions, 1 - 26 GHz	FCC Part 15.209 / 15.407	41.0dBµV/m @ 3000.0MHz (-13.0dB)
1c	802.11a Chain A	5240	GC = 26.5	AP = 16.6	Radiated Emissions, 1 - 26 GHz	FCC Part 15.209 / 15.407	53.4 dBuV/m @ 6986.7 MHz (-14.9dB)
2a	802.11a Chain A	5260	GC = 26	AP = 16.5	Radiated Emissions, 1 - 26 GHz	FCC Part 15.209 / 15.407	52.9 dBuV/m @ 7013.3 MHz (-15.4dB)
2b	802.11a Chain A	5280	GC = 25.5	AP = 16.5	Radiated Emissions, 1 - 26 GHz	FCC Part 15.209 / 15.407	52.7 dBuV/m @ 7039.9MHz (-15.6dB)
2c	802.11a Chain A	5320	GC = 24.5	AP = 16.6	Radiated Emissions, 1 - 26 GHz	FCC Part 15.209 / 15.407	48.5dBµV/m @ 10639.8MHz (-5.5dB)
3a	802.11a Chain A	5500	GC = 24.5	AP = 16.6	Radiated Emissions, 1 - 26 GHz	FCC Part 15.209 / 15.407	48.1dBµV/m @ 11000.6MHz (-5.9dB)
3b	802.11a Chain A	5600	GC = 25	AP = 16.6	Radiated Emissions, 1 - 26 GHz	FCC Part 15.209 / 15.407	49.1dBµV/m @ 11201.1MHz (-4.9dB)
3c	802.11a Chain A	5700	GC = 26	AP = 16.5	Radiated Emissions, 1 - 26 GHz	FCC Part 15.209 / 15.407	40.4dBµV/m @ 11400.7MHz (-13.6dB)

Client: Intel	Job Number: J70979
Model: 512an MMW	T-Log Number: T71832
	Account Manager: Briggs / Eriksen
Contact: Robert Paxman	
Standard: RSS 210 / FCC 15.407 UNII (Radiated)	Class: N/A

Run #1: Radiated Spurious Emissions, 1000 - 40000 MHz. Operating Mode: 802.11a Chain A
 Date of Test: 6/2/2008
 Test Engineer: Ben Jing and Jack Plotner
 Test Location: Chamber # 5

Run #1a: Low Channel @ 5180 MHz
 Spurious Emissions

Frequency MHz	Level dB μ V/m	Pol v/h	15.209 / 15.407		Detector PK/QP/Avg	Azimuth degrees	Height meters	Comments
			Limit	Margin				
1991.910	28.1	V	54.0	-25.9	AVG	183	1.0	
2496.220	30.0	V	54.0	-24.0	AVG	150	1.5	
6906.580	57.0	V	68.3	-11.3	AVG	172	1.5	Note 2
10360.380	53.2	V	68.3	-15.1	AVG	143	1.0	Note 2
1991.910	42.6	V	74.0	-31.4	PK	183	1.0	
2496.220	47.8	V	74.0	-26.2	PK	150	1.5	
6906.580	58.6	V	88.3	-9.7	PK	172	1.5	Note 2
10360.380	65.3	V	88.3	-23.0	PK	143	1.0	Note 2

Note 1: For emissions in restricted bands, the limit of 15.209 was used. For all other emissions, the limit was set to -27dBm eirp (68.3dBuV/m average, 88.3dBuV/m peak)

Note 2: Signal is not in a restricted band

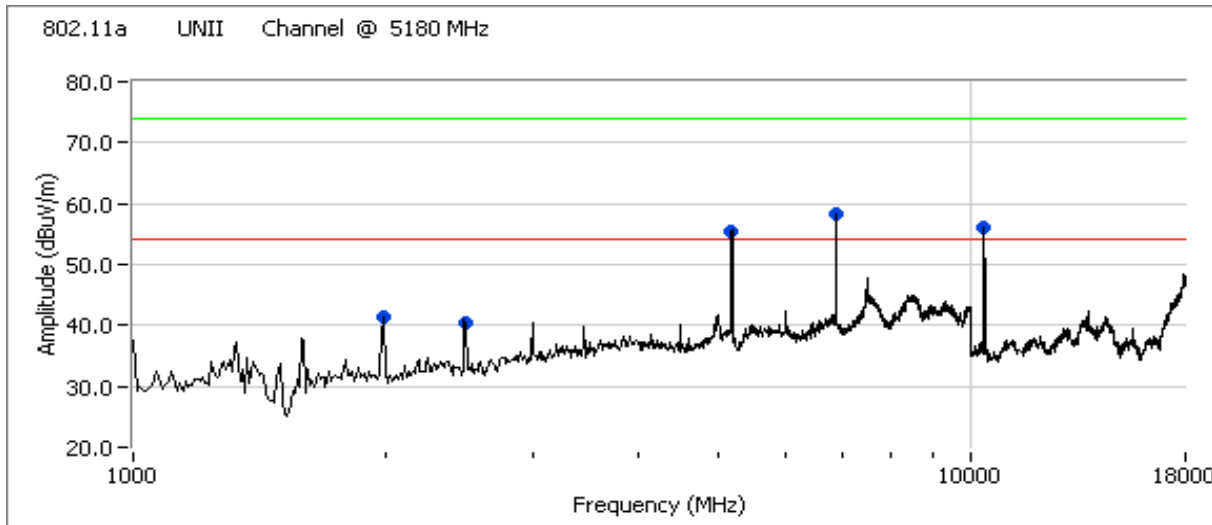

Client: Intel	Job Number: J70979
Model: 512an MMW	T-Log Number: T71832
Contact: Robert Paxman	Account Manager: Briggs / Eriksen
Standard: RSS 210 / FCC 15.407 UNII (Radiated)	Class: N/A

Run #1b: Center Channel @ 5200 MHz

Spurious Emissions

Frequency MHz	Level dB μ V/m	Pol v/h	15.209 / 15.407		Detector Pk/QP/Avg	Azimuth degrees	Height meters	Comments
			Limit	Margin				
2999.980	41.0	V	54.0	-13.0	AVG	261	1.0	
6933.330	54.9	V	68.3	-13.4	AVG	198	1.5	Note 2
10400.000	50.1	V	68.3	-18.2	AVG	143	1.0	Note 2
2999.980	46.1	V	74.0	-27.9	PK	261	1.0	
6933.330	57.0	V	88.3	-21.3	PK	198	1.5	Note 2
10400.000	62.5	V	88.3	-25.8	PK	143	1.0	Note 2

Note 1: For emissions in restricted bands, the limit of 15.209 was used. For all other emissions, the limit was set to -27dBm eirp (68.3dBuV/m average, 88.3dBuV/m peak)

Note 2: Signal is not in a restricted band.

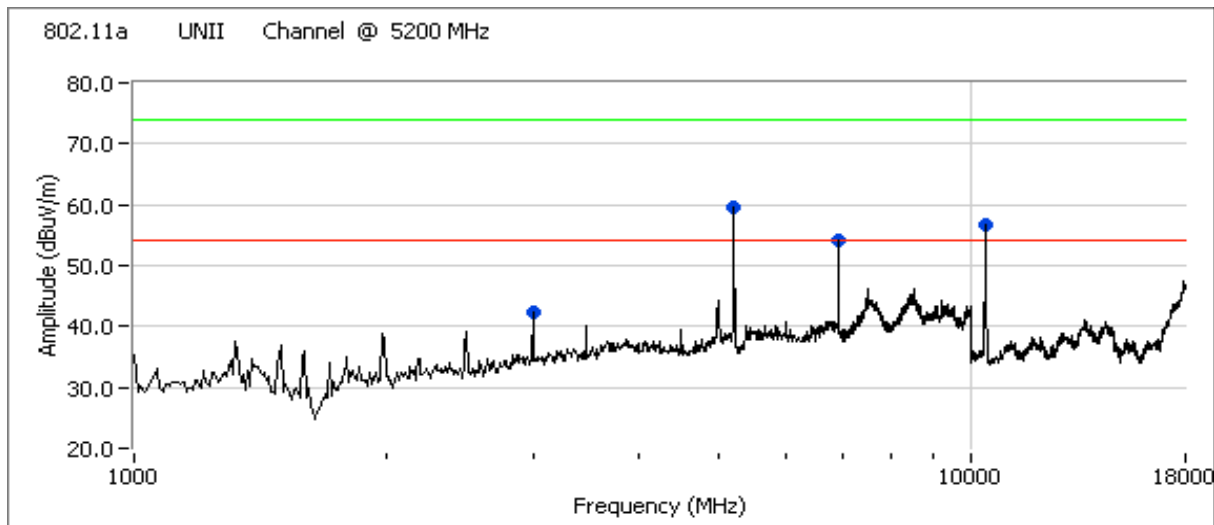

Client: Intel	Job Number: J70979
Model: 512an MMW	T-Log Number: T71832
	Account Manager: Briggs / Eriksen
Contact: Robert Paxman	
Standard: RSS 210 / FCC 15.407 UNII (Radiated)	Class: N/A

Run #1c: High Channel @ 5240 MHz

Spurious Emissions

Frequency MHz	Level dB μ V/m	Pol v/h	15.209 / 15.407		Detector Pk/QP/Avg	Azimuth degrees	Height meters	Comments
			Limit	Margin				
6986.670	50.8	V	68.3	-17.5	AVG	208	1.0	Note 2
10479.830	49.0	V	68.3	-19.3	AVG	140	1.0	Note 2
6986.670	53.4	V	88.3	-14.9	PK	208	1.0	Note 2
10479.830	61.1	V	88.3	-17.2	PK	140	1.0	Note 2

Note 1: For emissions in restricted bands, the limit of 15.209 was used. For all other emissions, the limit was set to -27dBm eirp (68.3dBuV/m average, 88.3dBuV/m peak)

Note 2: Signal is not in a restricted band.

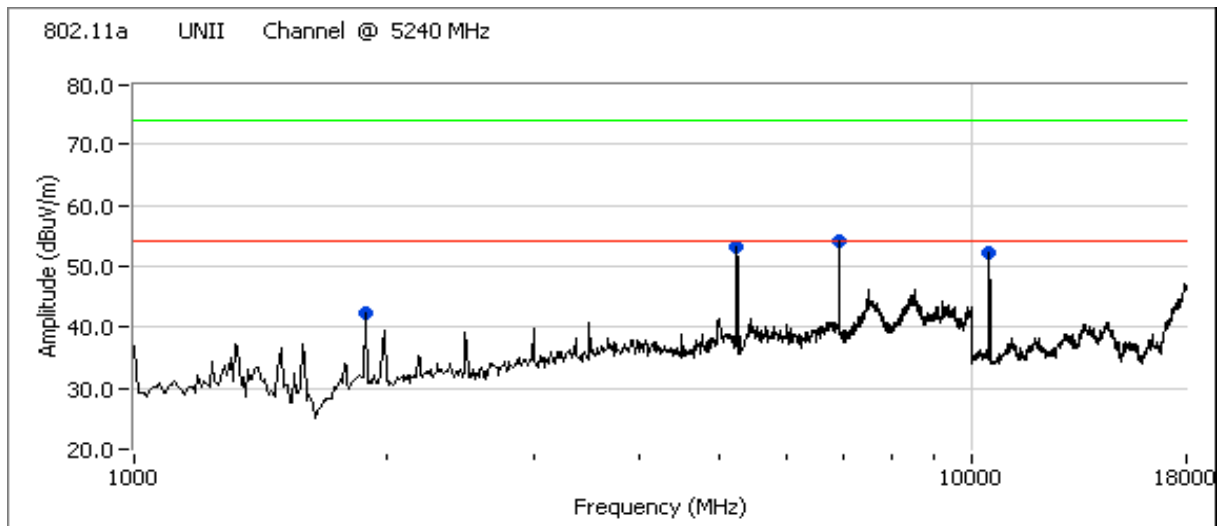

Client: Intel	Job Number: J70979
Model: 512an MMW	T-Log Number: T71832
Contact: Robert Paxman	Account Manager: Briggs / Eriksen
Standard: RSS 210 / FCC 15.407 UNII (Radiated)	Class: N/A

Run #2: Radiated Spurious Emissions, 1000 - 40000 MHz. Operating Mode: 802.11a Chain A

Date of Test: 6/2/2008

Test Engineer: Ben Jing and Jack Plotner

Test Location: Chamber # 5

Run #2a: Low Channel @ 5260 MHz

Spurious Emissions

Frequency MHz	Level dB μ V/m	Pol v/h	15.209 / 15.407		Detector PK/QP/Avg	Azimuth degrees	Height meters	Comments
			Limit	Margin				
3000.010	42.1	V	68.3	-26.2	AVG	260	1.0	Note 2
7013.250	52.9	V	68.3	-15.4	AVG	182	1.5	Note 2
10520.010	52.9	V	68.3	-15.4	AVG	220	1.0	Note 2
3000.010	42.5	V	88.3	-56.8	PK	261	1.0	Note 2
7013.250	52.6	V	88.3	-35.7	PK	175	1.5	Note 2
10520.010	52.9	V	88.3	-35.4	PK	220	1.0	Note 2

Note 1: For emissions in restricted bands, the limit of 15.209 was used. For all other emissions, the limit was set to -27dBm eirp (68.3dB μ V/m average, 88.3dB μ V/m peak)

Note 2: Signal is not in a restricted band.

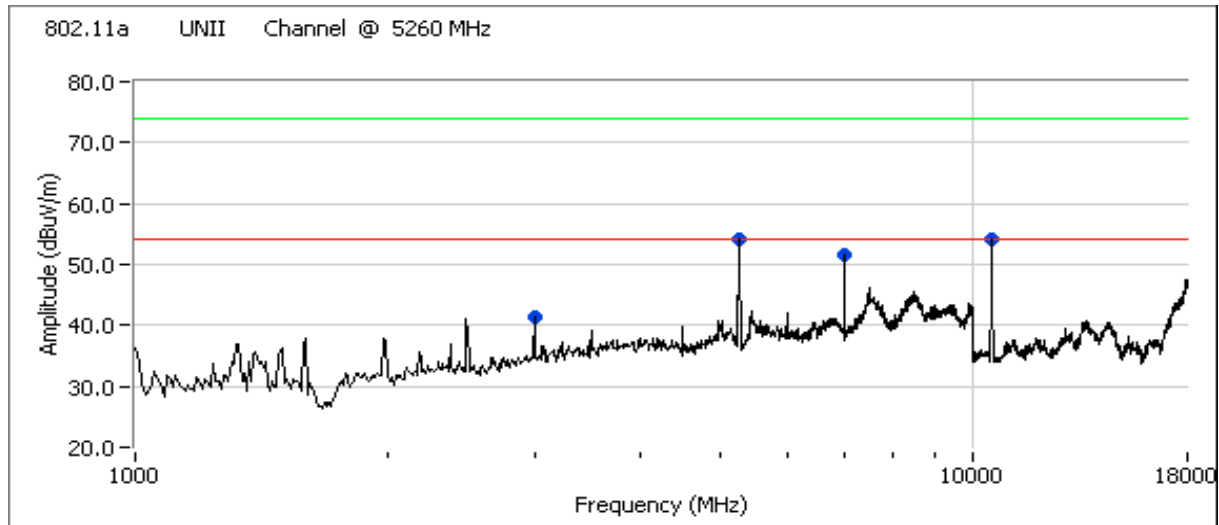

Client: Intel	Job Number: J70979
Model: 512an MMW	T-Log Number: T71832
Contact: Robert Paxman	Account Manager: Briggs / Eriksen
Standard: RSS 210 / FCC 15.407 UNII (Radiated)	Class: N/A

Run #2b: Center Channel @ 5280 MHz

Spurious Emissions

Frequency MHz	Level dB μ V/m	Pol v/h	15.209 / 15.407		Detector Pk/QP/Avg	Azimuth degrees	Height meters	Comments
			Limit	Margin				
3519.960	43.8	V	68.3	-24.5	AVG	171	1.3	Note 2
7039.920	52.7	V	68.3	-15.6	AVG	198	1.6	
10558.650	52.1	V	68.3	-16.2	AVG	210	1.0	Note 2
3519.970	44.0	V	88.3	-44.3	PK	171	1.9	Note 2
7039.920	52.8	V	88.3	-35.5	PK	198	1.6	
10561.480	52.8	V	88.3	-35.5	PK	217	1.0	Note 2

Note 1: For emissions in restricted bands, the limit of 15.209 was used. For all other emissions, the limit was set to -27dBm eirp (68.3dBuV/m average, 88.3dBuV/m peak)

Note 2: Signal is not in a restricted band.

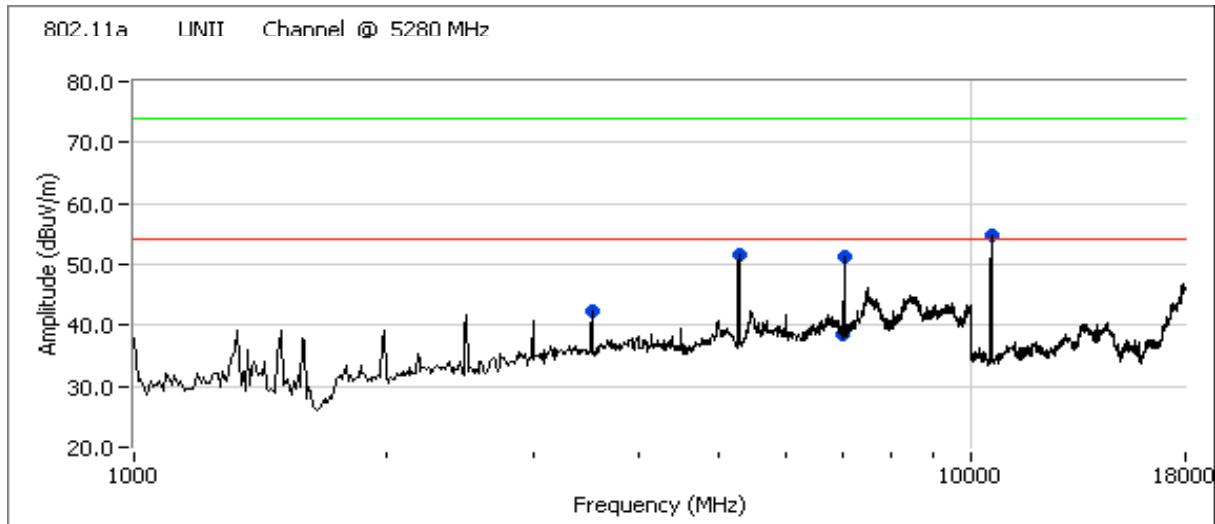

Client: Intel	Job Number: J70979
Model: 512an MMW	T-Log Number: T71832
	Account Manager: Briggs / Eriksen
Contact: Robert Paxman	
Standard: RSS 210 / FCC 15.407 UNII (Radiated)	Class: N/A

Run #2c: High Channel @ 5320 MHz
 Date of Test: 6/3/2008
 Test Engineer: Ben Jing and Jack Plotner
 Test Location: Chamber # 5

Spurious Emissions

Frequency MHz	Level dB μ V/m	Pol v/h	15.209 / 15.407		Detector PK/QP/Avg	Azimuth degrees	Height meters	Comments
			Limit	Margin				
1996.980	33.6	V	68.3	-34.7	AVG	253	1.0	Note 2
2497.950	30.0	H	54.0	-24.0	AVG	203	1.0	
3000.000	37.3	V	68.3	-31.0	AVG	247	1.0	Note 2
3546.630	39.9	V	68.3	-28.4	AVG	168	1.5	Note 2
7093.210	50.8	H	68.3	-17.5	AVG	188	1.0	Note 2
10639.840	48.5	V	54.0	-5.5	AVG	126	1.3	
1996.980	49.7	V	88.3	-38.6	PK	253	1.0	Note 2
2497.950	48.5	H	74.0	-25.5	PK	203	1.0	
3000.000	43.0	V	88.3	-45.3	PK	247	1.0	Note 2
3546.630	44.8	V	88.3	-43.5	PK	168	1.5	Note 2
7093.210	53.2	H	88.3	-35.1	PK	188	1.0	Note 2
10639.840	60.6	V	74.0	-13.4	PK	126	1.3	

- Note 1: For emissions in restricted bands, the limit of 15.209 was used. For all other emissions, the limit was set to -27dBm eirp (68.3dBuV/m average, 88.3dBuV/m peak)
- Note 2: Signal is not in a restricted band.

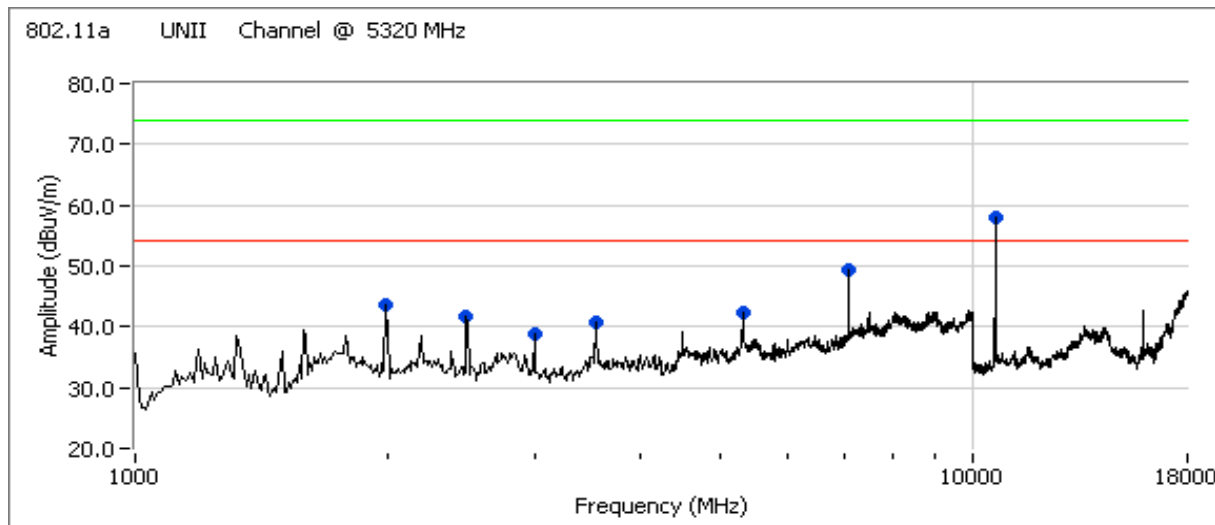

Client: Intel	Job Number: J70979
Model: 512an MMW	T-Log Number: T71832
	Account Manager: Briggs / Eriksen
Contact: Robert Paxman	
Standard: RSS 210 / FCC 15.407 UNII (Radiated)	Class: N/A

Run #3: Radiated Spurious Emissions, 1000 - 40000 MHz. Operating Mode: 802.11a Chain A

Date of Test: 6/3/2008
 Test Engineer: Ben Jing and Jack Plotner
 Test Location: Chamber # 5

Run #3a: Low Channel @ 5500 MHz

Spurious Emissions

Frequency MHz	Level dB μ V/m	Pol v/h	15.209 / 15.407		Detector PK/QP/Avg	Azimuth degrees	Height meters	Comments
			Limit	Margin				
1996.850	32.2	V	54.0	-21.8	AVG	250	1.0	
2490.100	30.2	H	54.0	-23.8	AVG	221	1.0	
3000.060	36.0	V	54.0	-18.0	AVG	262	1.0	
7333.220	44.8	V	68.3	-23.5	AVG	73	1.6	Note 2
11000.630	48.1	V	54.0	-5.9	AVG	281	1.0	
1996.850	46.8	V	74.0	-27.2	PK	250	1.0	
2490.100	48.5	H	74.0	-25.5	PK	221	1.0	
3000.060	42.4	V	74.0	-31.6	PK	262	1.0	
7333.220	49.8	V	88.3	-38.5	PK	73	1.6	Note 2
11000.630	60.6	V	74.0	-13.4	PK	281	1.0	

- Note 1:* For emissions in restricted bands, the limit of 15.209 was used. For all other emissions, the limit was set to -27dBm eirp (68.3dBuV/m average, 88.3dBuV/m peak)
- Note 2:* Signal is not in a restricted band.

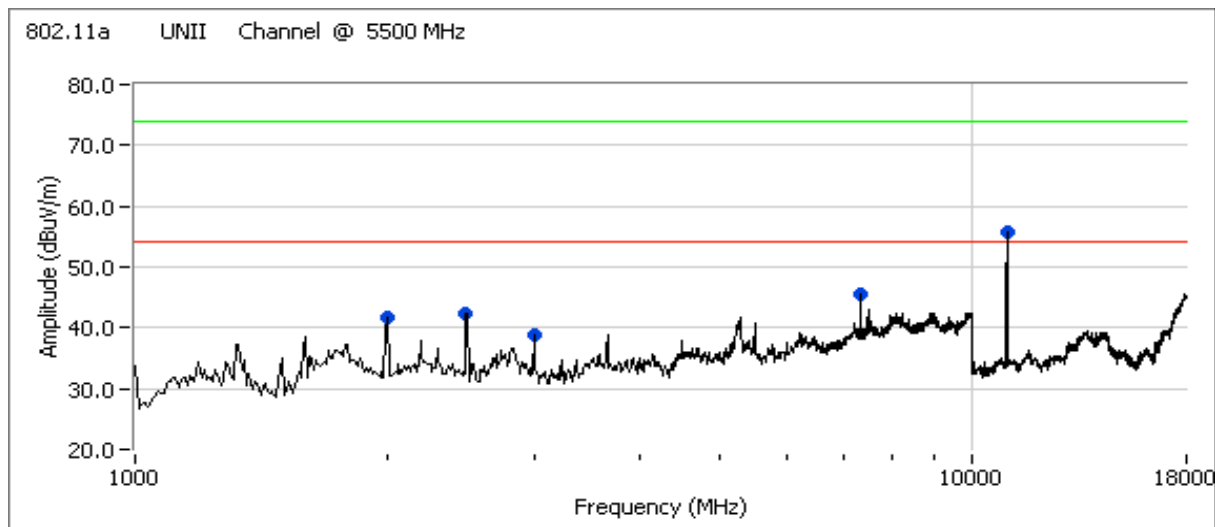

Client: Intel	Job Number: J70979
Model: 512an MMW	T-Log Number: T71832
Contact: Robert Paxman	Account Manager: Briggs / Eriksen
Standard: RSS 210 / FCC 15.407 UNII (Radiated)	Class: N/A

Run #3b: Center Channel @ 5600 MHz

Spurious Emissions

Frequency MHz	Level dB μ V/m	Pol v/h	15.209 / 15.407		Detector Pk/QP/Avg	Azimuth degrees	Height meters	Comments
			Limit	Margin				
1991.640	37.3	V	68.3	-31.0	AVG	253	1.0	Note 2
2489.130	48.5	H	54.0	-5.5	AVG	248	1.0	
3000.010	38.9	V	68.3	-29.4	AVG	252	1.0	Note 2
7466.650	43.2	V	54.0	-10.8	AVG	101	1.5	
11201.140	49.1	V	54.0	-4.9	AVG	144	1.0	
1991.640	37.2	V	88.3	-51.1	PK	255	1.0	Note 2
2491.270	48.5	H	74.0	-25.5	PK	248	1.0	
3000.010	39.3	V	88.3	-49.0	PK	255	1.0	Note 2
7466.580	48.7	V	74.0	-25.3	PK	97	1.5	
11201.140	61.8	V	74.0	-12.2	PK	144	1.0	

Note 1: For emissions in restricted bands, the limit of 15.209 was used. For all other emissions, the limit was set to -27dBm eirp (68.3dBuV/m average, 88.3dBuV/m peak)

Note 2: Signal is not in a restricted band.

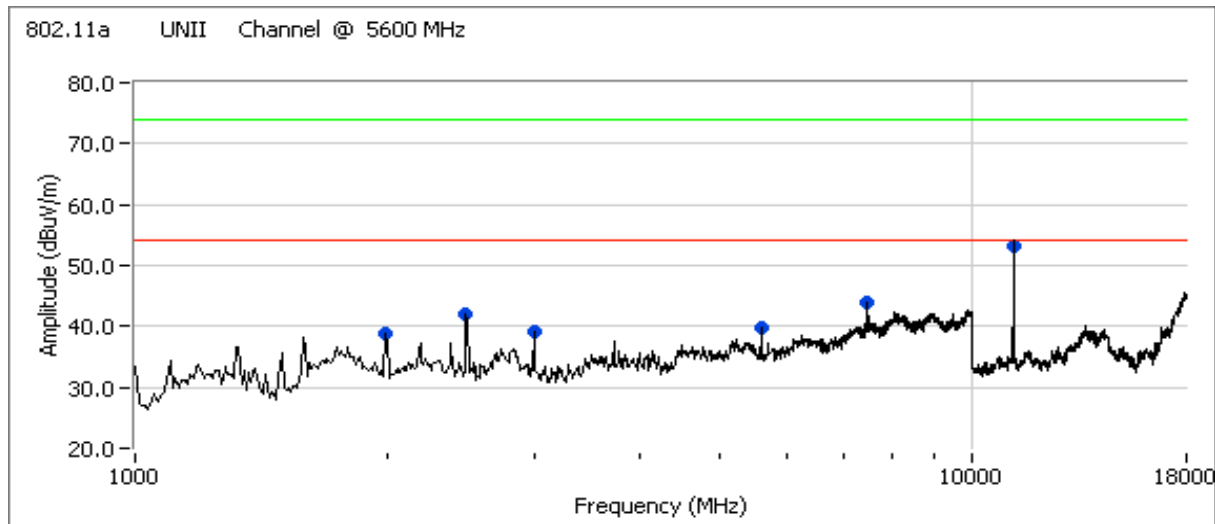

Client: Intel	Job Number: J70979
Model: 512an MMW	T-Log Number: T71832
Contact: Robert Paxman	Account Manager: Briggs / Eriksen
Standard: RSS 210 / FCC 15.407 UNII (Radiated)	Class: N/A

Run #3c: High Channel @ 5700 MHz

Spurious Emissions

Frequency MHz	Level dB μ V/m	Pol v/h	15.209 / 15.407		Detector Pk/QP/Avg	Azimuth degrees	Height meters	Comments
			Limit	Margin				
2488.900	33.1	H	54.0	-20.9	AVG	194	1.0	
3000.000	35.3	V	68.3	-33.0	AVG	245	1.5	Note 2
7599.970	39.0	V	54.0	-15.0	AVG	96	1.5	
11400.670	40.4	V	54.0	-13.6	AVG	142	1.0	
2488.900	49.5	H	74.0	-24.5	PK	194	1.0	
3000.000	42.2	V	88.3	-46.1	PK	245	1.5	Note 2
7599.970	46.9	V	74.0	-27.1	PK	96	1.5	
11400.670	52.5	V	74.0	-21.5	PK	142	1.0	

Note 1: For emissions in restricted bands, the limit of 15.209 was used. For all other emissions, the limit was set to -27dBm eirp (68.3dBuV/m average, 88.3dBuV/m peak)

Note 2: Signal is not in a restricted band.



Client: Intel	Job Number: J70979
Model: 512an MMW	T-Log Number: T71832
	Account Manager: Briggs / Eriksen
Contact: Robert Paxman	
Standard: RSS 210 / FCC 15.407 UNII (Radiated)	Class: N/A

Run #1: Radiated Spurious Emissions, 1000 - 40000 MHz. Operating Mode: 802.11n 20MHz Chain A
 For operation in the 5150-5250 MHz band 802.11a mode has the highest emissions based on testing with the ethertronics antenna.

Run #2: Radiated Spurious Emissions, 1000 - 40000 MHz. Operating Mode: 802.11n20 Chain A
 In the 5250-5350 MHz band 802.11a and 802.11n modes had the highest emissions based on testing with the ethertronics antenna.

Run #3: Radiated Spurious Emissions, 1000 - 40000 MHz. Operating Mode: 802.11n20 Chain A
 Date of Test: 6/3/2008
 Test Engineer: Ben Jing
 Test Location: Chamber # 5

Run #3a: Low Channel @ 5500 MHz

Spurious Emissions

Frequency	Level	Pol	15.209 / 15.407		Detector	Azimuth	Height	Comments
MHz	dBuV/m	v/h	Limit	Margin	Pk/QP/Avg	degrees	meters	
2490.180	30.4	H	54.0	-23.6	AVG	213	1.0	
7333.310	46.3	V	54.0	-7.7	AVG	145	2.0	
10996.680	49.8	V	54.0	-4.2	AVG	138	1.0	
2490.180	48.8	H	74.0	-25.2	PK	213	1.0	
7333.310	51.3	V	74.0	-22.7	PK	145	2.0	
10996.680	63.0	V	74.0	-11.0	PK	138	1.0	

Note 1: For emissions in restricted bands, the limit of 15.209 was used. For all other emissions, the limit was set to -27dBm eirp (68.3dBuV/m average, 88.3dBuV/m peak)

Note 2: Signal is not in a restricted band.

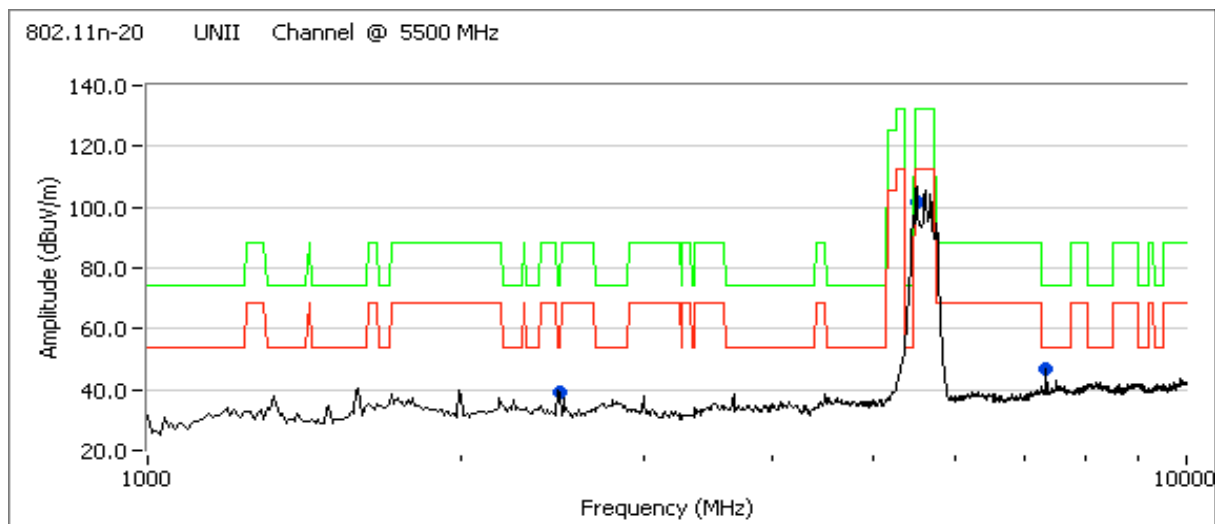

Client: Intel	Job Number: J70979
Model: 512an MMW	T-Log Number: T71832
Contact: Robert Paxman	Account Manager: Briggs / Eriksen
Standard: RSS 210 / FCC 15.407 UNII (Radiated)	Class: N/A

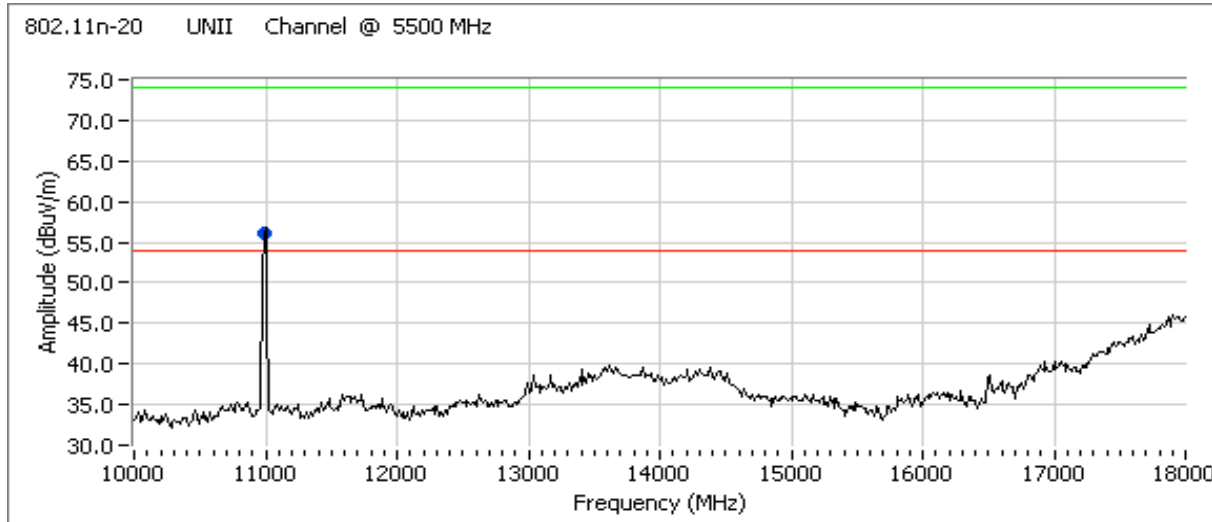

Run #3b: Center Channel @ 5600 MHz

Spurious Emissions

Frequency	Level	Pol	15.209 / 15.407		Detector	Azimuth	Height	Comments
MHz	dB μ V/m	v/h	Limit	Margin	Pk/QP/Avg	degrees	meters	
2490.000	29.9	V	54.0	-24.1	AVG	154	1.5	
7466.610	40.2	V	54.0	-13.8	AVG	260	1.5	
11200.940	49.7	V	54.0	-4.3	AVG	138	1.0	
2490.000	47.4	V	74.0	-26.6	PK	154	1.5	
7466.610	47.7	V	74.0	-26.3	PK	260	1.5	
11200.940	62.9	V	74.0	-11.1	PK	138	1.0	

- Note 1: For emissions in restricted bands, the limit of 15.209 was used. For all other emissions, the limit was set to -27dBm eirp (68.3dBuV/m average, 88.3dBuV/m peak)
- Note 2: Signal is not in a restricted band.

Client: Intel	Job Number: J70979
Model: 512an MMW	T-Log Number: T71832
Contact: Robert Paxman	Account Manager: Briggs / Eriksen
Standard: RSS 210 / FCC 15.407 UNII (Radiated)	Class: N/A

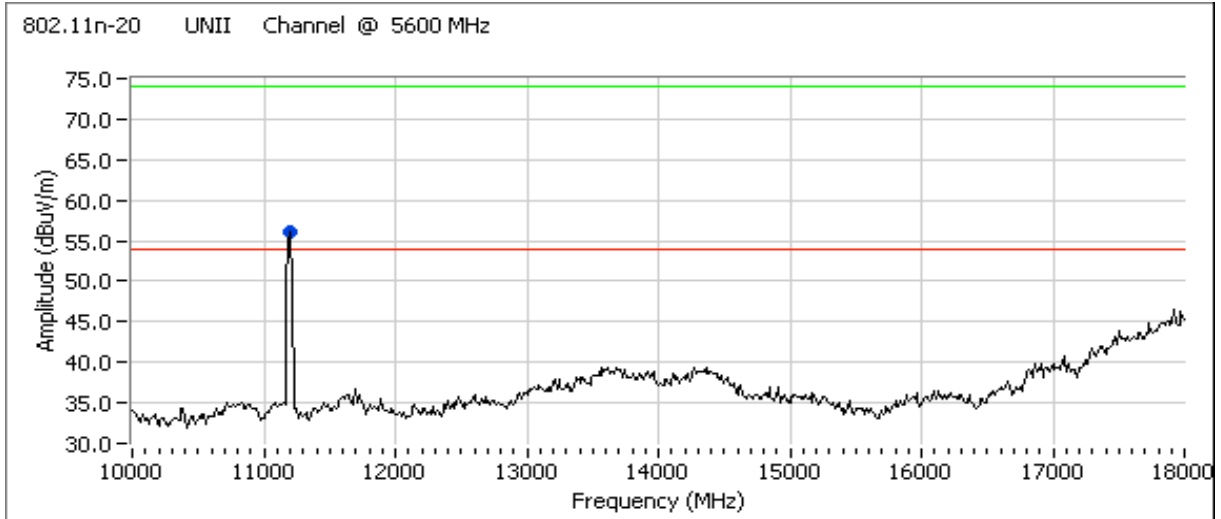
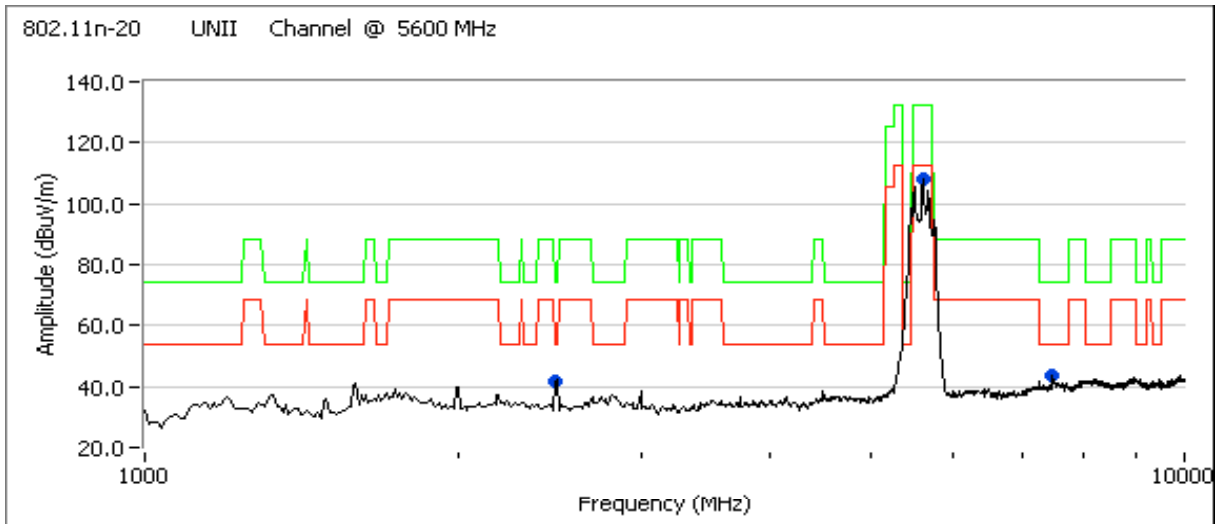

Client: Intel	Job Number: J70979
Model: 512an MMW	T-Log Number: T71832
Contact: Robert Paxman	Account Manager: Briggs / Eriksen
Standard: RSS 210 / FCC 15.407 UNII (Radiated)	Class: N/A

Run #3c: High Channel @ 5700 MHz

Spurious Emissions

Frequency MHz	Level dB μ V/m	Pol v/h	15.209 / 15.407		Detector Pk/QP/Avg	Azimuth degrees	Height meters	Comments
			Limit	Margin				
2489.880	30.0	V	54.0	-24.0	AVG	164	1.5	
7599.960	41.0	V	54.0	-13.0	AVG	127	1.0	
11400.070	38.7	V	54.0	-15.3	AVG	282	1.0	
2489.880	47.8	V	74.0	-26.2	PK	164	1.5	
7599.960	48.0	V	74.0	-26.0	PK	127	1.0	
11400.070	51.0	V	74.0	-23.0	PK	282	1.0	

Note 1: For emissions in restricted bands, the limit of 15.209 was used. For all other emissions, the limit was set to -27dBm eirp (68.3dBuV/m average, 88.3dBuV/m peak)

Note 2: Signal is not in a restricted band.

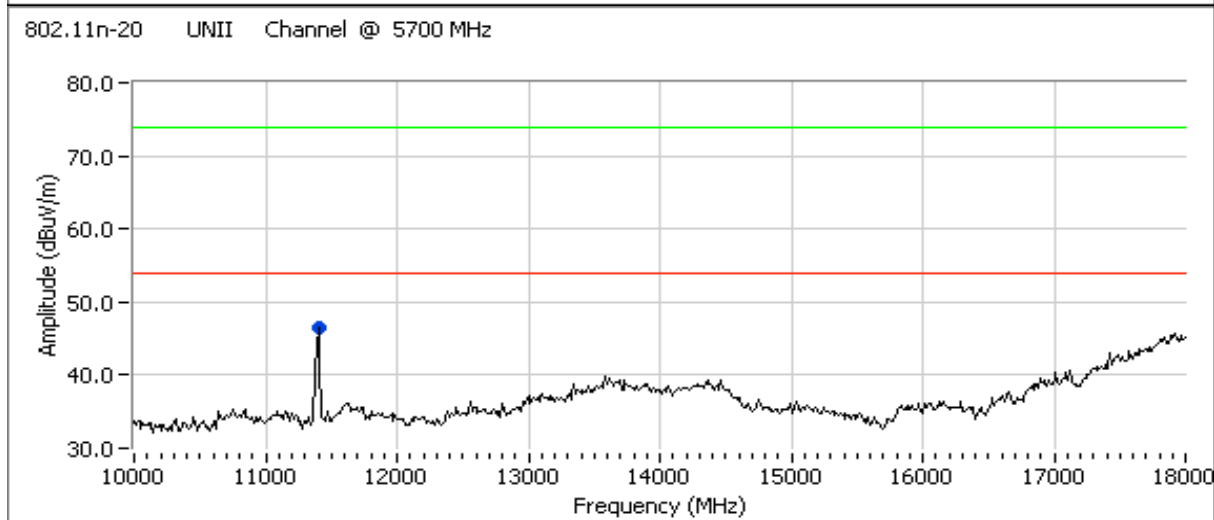
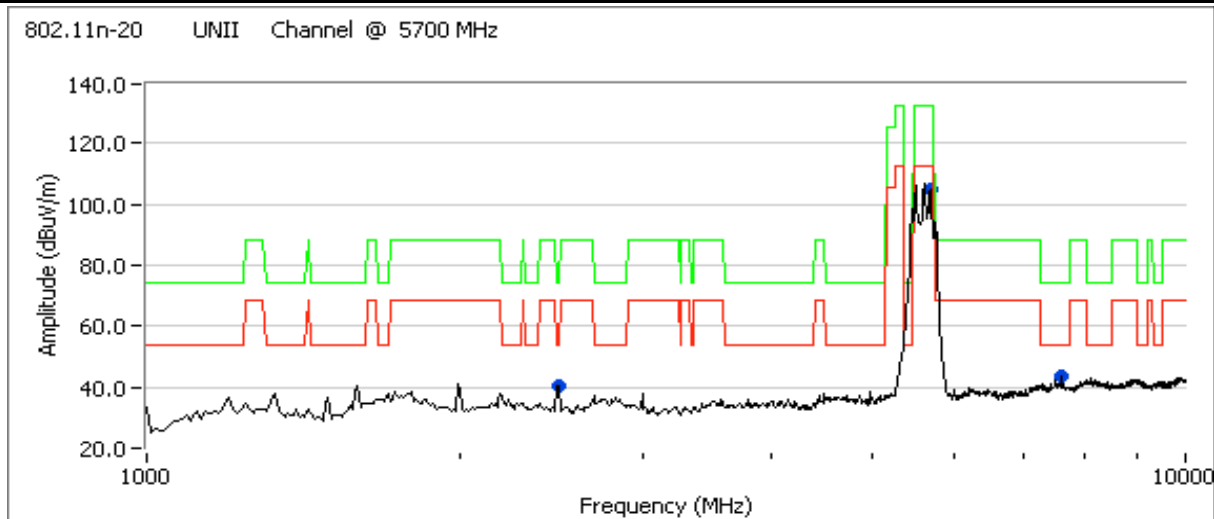

Client: Intel	Job Number: J70979
Model: 512an MMW	T-Log Number: T71832
	Account Manager: Briggs / Eriksen
Contact: Robert Paxman	
Standard: RSS 210 / FCC 15.407 UNII (Radiated)	Class: N/A

**RSS 210 and FCC 15.E (U-NII, 5150- 550/5250-5350/5460-5725MHz)
Radiated Spurious Emissions, 1 - 40GHz 802.11n 40MHz Mode**

Test Specific Details

Objective: The objective of this test session is to perform final qualification testing of the EUT with respect to the specification listed above.

Date of Test: 6/4/2008	Config. Used: 1
Test Engineer: Ben Jing/Jack Plotner/Joe Cadigal	Config Change: None
Test Location: Chamber # 5	Host Unit Voltage 120V/60Hz

General Test Configuration

The EUT and all local support equipment were located on the turntable for radiated spurious emissions testing. All remote support equipment was located approximately 30 meters from the EUT with all I/O connections running on top of the groundplane.

For radiated emissions testing the measurement antenna was located 3 meters from the EUT.

Ambient Conditions:	4-Jun	6-Jun
	Temperature: 23	28 °C
	Rel. Humidity: 34	38 %

Run #	Mode	Channel	Power Setting	Measured Power	Test Performed	Limit	Result / Margin
1a	802.11n20 Chain A	5190	26.5	16.5	Radiated Emissions, 1 - 40 GHz	FCC Part 15.209 / 15.407	802.11a mode is worst case in this sub-band
1b	802.11n20 Chain A	5230	26.0	16.6	Radiated Emissions, 1 - 40 GHz	FCC Part 15.209 / 15.407	
2a	802.11n20 Chain A	5270	25.5	16.7	Radiated Emissions, 1 - 40 GHz	FCC Part 15.209 / 15.407	50.1dBµV/m @ 10540.2MHz (-18.2dB)
2b	802.11n20 Chain A	5310	25.0	16.5	Radiated Emissions, 1 - 40 GHz	FCC Part 15.209 / 15.407	49.4dBµV/m @ 10619.8MHz (-4.6dB)
3a	802.11n20 Chain A	5510	24.5	16.6	Radiated Emissions, 1 - 40 GHz	FCC Part 15.209 / 15.407	44.2dBµV/m @ 11019.8MHz (-9.8dB)
3b	802.11n20 Chain A	5590	23.0	16.9	Radiated Emissions, 1 - 40 GHz	FCC Part 15.209 / 15.407	46.9dBµV/m @ 11176.4MHz (-7.1dB)
3c	802.11n20 Chain A	5670	26.5	16.9	Radiated Emissions, 1 - 40 GHz	FCC Part 15.209 / 15.407	31.8dBµV/m @ 11338.5MHz (-22.2dB)

Modifications Made During Testing

No modifications were made to the EUT during testing

Deviations From The Standard

No deviations were made from the requirements of the standard.

Client: Intel	Job Number: J70979
Model: 512an MMW	T-Log Number: T71832
Contact: Robert Paxman	Account Manager: Briggs / Eriksen
Standard: RSS 210 / FCC 15.407 UNII (Radiated)	Class: N/A

Run #1: Radiated Spurious Emissions, 1000 - 40000 MHz. Operating Mode: 802.11n 40MHz Chain A
 For operation in the 5150-5250 MHz band 802.11a mode has the highest emissions based on testing with the ethertronics antenna.

Run #2: Radiated Spurious Emissions, 1000 - 40000 MHz. Operating Mode: 802.11n40 Chain A

Run #2a: Low Channel @ 5270 MHz

Spurious Emissions

Frequency MHz	Level dB μ V/m	Pol v/h	15.209 / 15.247		Detector PK/QP/Avg	Azimuth degrees	Height meters	Comments
			Limit	Margin				
1997.060	33.8	V	68.3	-34.5	AVG	246	1.0	Note 2
2497.720	30.7	V	54.0	-23.3	AVG	258	1.0	
7026.610	48.5	V	68.3	-19.8	AVG	219	1.5	Note 2
10540.180	50.1	V	68.3	-18.2	AVG	135	1.0	Note 2
1997.060	47.9	V	88.3	-40.4	PK	246	1.0	Note 2
2497.720	50.3	V	74.0	-23.7	PK	258	1.0	
7026.610	51.4	V	88.3	-36.9	PK	219	1.5	Note 2
10540.180	61.5	V	88.3	-26.8	PK	135	1.0	Note 2

Note 1: For emissions in restricted bands, the limit of 15.209 was used. For all other emissions, the limit was set to -27dBm eirp (68.3dB μ V/m average, 88.3dB μ V/m peak)

Note 2: Signal is not in a restricted band.

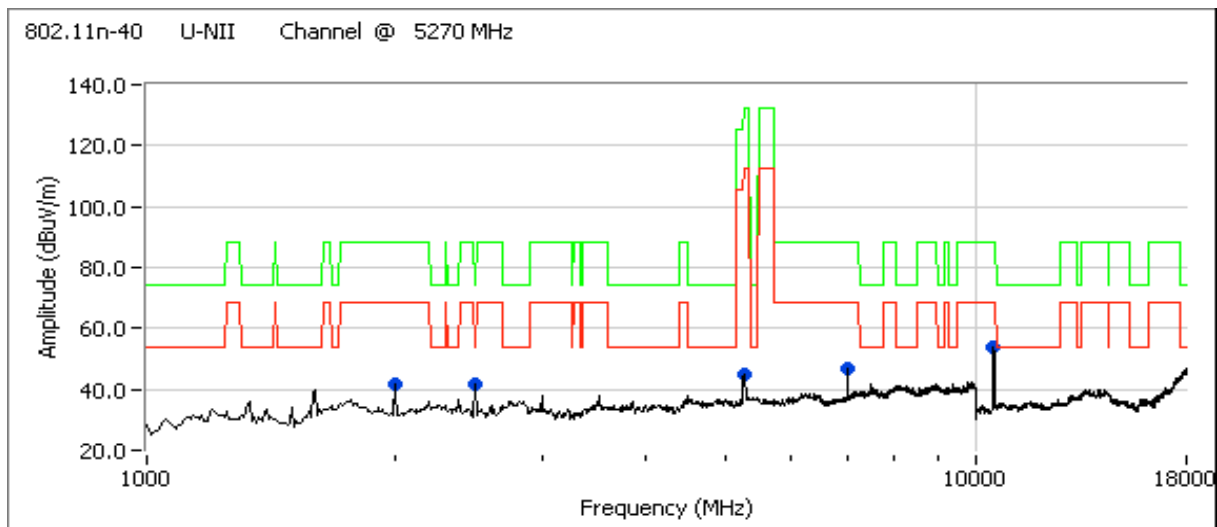

Client: Intel	Job Number: J70979
Model: 512an MMW	T-Log Number: T71832
	Account Manager: Briggs / Eriksen
Contact: Robert Paxman	
Standard: RSS 210 / FCC 15.407 UNII (Radiated)	Class: N/A

Run #2b: High Channel @ 5310 MHz

Spurious Emissions

Frequency MHz	Level dB μ V/m	Pol v/h	15.209 / 15.247		Detector Pk/QP/Avg	Azimuth degrees	Height meters	Comments
			Limit	Margin				
7079.940	50.5	V	68.3	-17.8	AVG	210	1.0	Note 2
10619.790	49.4	V	54.0	-4.6	AVG	136	1.3	
7079.940	52.9	V	88.3	-35.4	PK	210	1.0	Note 2
10619.790	61.1	V	74.0	-12.9	PK	136	1.3	

Note 1: For emissions in restricted bands, the limit of 15.209 was used. For all other emissions, the limit was set to -27dBm eirp (68.3dBuV/m average, 88.3dBuV/m peak)

Note 2: Signal is not in a restricted band.

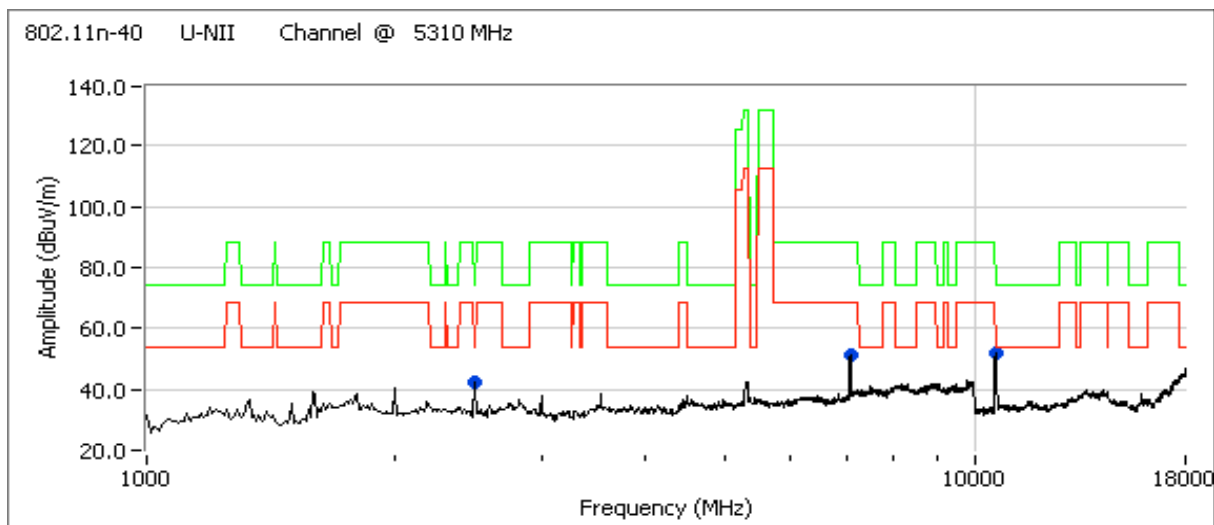

Client: Intel	Job Number: J70979
Model: 512an MMW	T-Log Number: T71832
	Account Manager: Briggs / Eriksen
Contact: Robert Paxman	
Standard: RSS 210 / FCC 15.407 UNII (Radiated)	Class: N/A

Run #3: Radiated Spurious Emissions, 1000 - 40000 MHz. Operating Mode: 802.11n40 Chain A

Run #3a: Low Channel @ 5510 MHz

Spurious Emissions

Frequency MHz	Level dB μ V/m	Pol v/h	15.209 / 15.247		Detector Pk/QP/Avg	Azimuth degrees	Height meters	Comments
			Limit	Margin				
7346.600	43.5	V	54.0	-10.5	AVG	93	1.5	
11019.800	44.2	V	54.0	-9.8	AVG	293	1.3	
7346.600	49.2	V	74.0	-24.8	PK	93	1.5	
11019.800	56.2	V	74.0	-17.8	PK	293	1.3	

Note 1: For emissions in restricted bands, the limit of 15.209 was used. For all other emissions, the limit was set to -27dBm eirp (68.3dBuV/m average, 88.3dBuV/m peak)

Note 2: Signal is not in a restricted band.

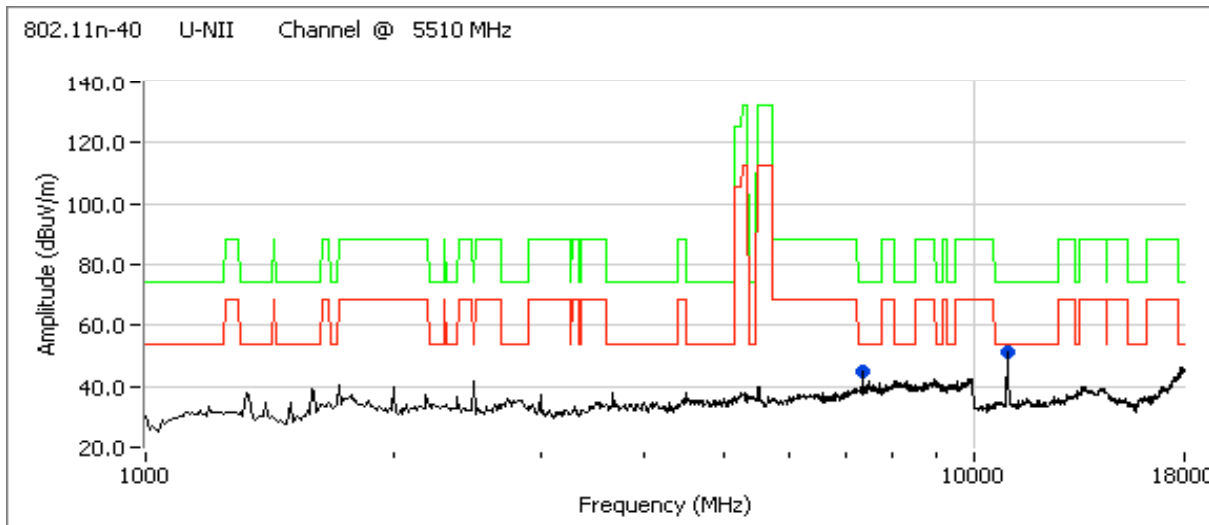

Client: Intel	Job Number: J70979
Model: 512an MMW	T-Log Number: T71832
Contact: Robert Paxman	Account Manager: Briggs / Eriksen
Standard: RSS 210 / FCC 15.407 UNII (Radiated)	Class: N/A

Run #3b: Center Channel @ 5590 MHz

Spurious Emissions

Frequency MHz	Level dB μ V/m	Pol v/h	15.209 / 15.247		Detector Pk/QP/Avg	Azimuth degrees	Height meters	Comments
			Limit	Margin				
2489.990	44.4	H	54.0	-9.6	AVG	128	1.4	
7453.160	43.8	V	54.0	-10.2	AVG	95	1.9	
11176.380	46.9	V	54.0	-7.1	AVG	149	1.0	
2489.850	44.1	H	74.0	-29.9	PK	128	1.9	
7453.160	49.0	V	74.0	-25.0	PK	95	1.9	
11176.380	59.2	V	74.0	-14.8	PK	149	1.0	

Note 1: For emissions in restricted bands, the limit of 15.209 was used. For all other emissions, the limit was set to -27dBm eirp (68.3dBuV/m average, 88.3dBuV/m peak)

Note 2: Signal is not in a restricted band.

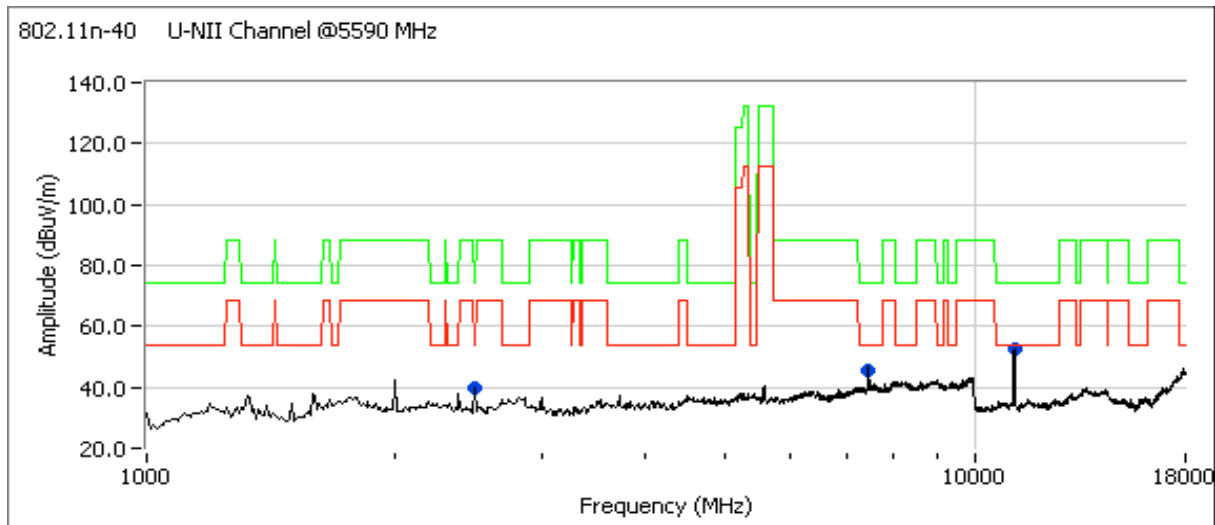

Client:	Intel	Job Number:	J70979
Model:	512an MMW	T-Log Number:	T71832
Contact:	Robert Paxman	Account Manager:	Briggs / Eriksen
Standard:	RSS 210 / FCC 15.407 UNII (Radiated)	Class:	N/A

Run #3c: High Channel @ 5670 MHz
Spurious Emissions

Frequency MHz	Level dB μ V/m	Pol v/h	15.209 / 15.247		Detector Pk/QP/Avg	Azimuth degrees	Height meters	Comments
			Limit	Margin				
7559.9	29.3	V	54.0	-24.7	AVG	60	2	
7559.9	24.4	H	54.0	-29.6	AVG	68	2	
11338.5	31.8	V	54.0	-22.2	AVG	315	2	
11340.2	29.8	H	54.0	-24.2	AVG	302	2	
7559.9	35.1	V	74.0	-38.9	PK	60	2	
7559.9	33.6	H	74.0	-40.4	PK	68	2	
11338.5	43.7	V	74.0	-30.3	PK	315	2	
11340.2	41.5	H	74.0	-32.5	PK	302	2	

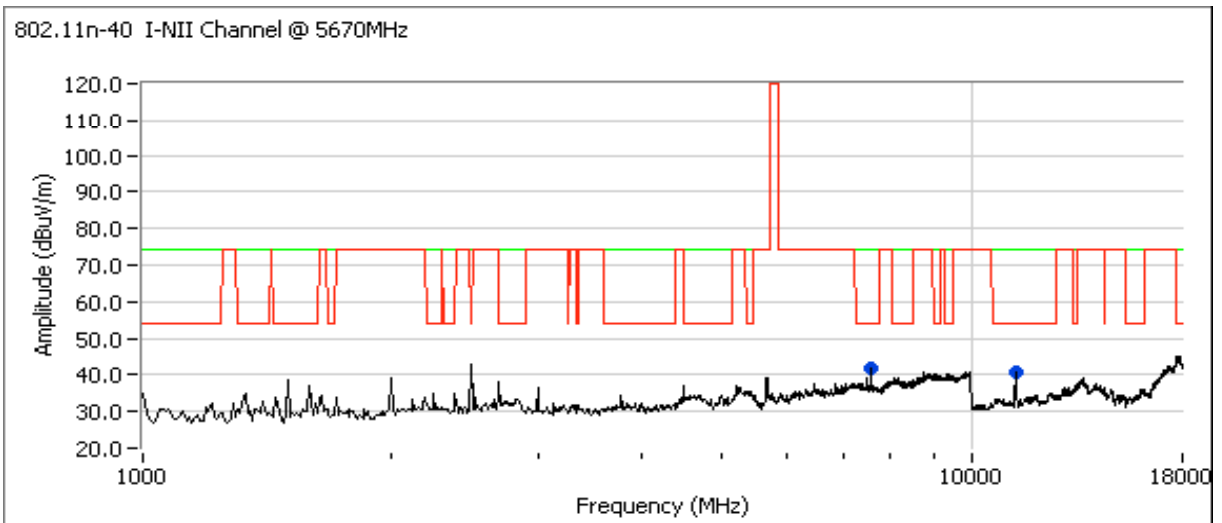

Note 1:	For emissions in restricted bands, the limit of 15.209 was used. For all other emissions, the limit was set to -27dBm eirp (68.3dBuV/m average, 88.3dBuV/m peak)
Note 2:	Signal is not in a restricted band.



EMC Test Data

Client:	Intel	Job Number:	J70979
Model:	512an MMW	T-Log Number:	T71040
		Account Manager:	Briggs / Eriksen
Contact:	Robert Paxman		-
Emissions Standard(s):	RSS 210 / FCC 15.247 DTS (Radiated)	Class:	DTS
Immunity Standard(s):	-	Environment:	-

**EMC Test Data - DTS Radiated Emissions
and AC Conducted Emissions**

For The

Intel

Model

512an MMW

Date of Last Test: 4/21/2008

Client: Intel	Job Number: J70979
Model: 512an MMW	T-Log Number: T71040
	Account Manager: Briggs / Eriksen
Contact: Robert Paxman	
Standard: RSS 210 / FCC 15.247 DTS (Radiated)	Class: DTS

Conducted Emissions

(Elliott Laboratories Fremont Facility, Semi-Anechoic Chamber)

Test Specific Details

Objective: The objective of this test session is to perform final qualification testing of the EUT with respect to the specification listed above.

Date of Test: 4/21/2008	Config. Used: 1
Test Engineer: Peter Sales	Config Change: None
Test Location: Fremont Chamber #5	Host Unit Voltage 120V/60Hz

General Test Configuration

For tabletop equipment, the EUT was located on a wooden table inside the semi-anechoic chamber, 40 cm from a vertical coupling plane and 80cm from the LISN. A second LISN was used for all local support equipment. Remote support equipment was located outside of the semi-anechoic chamber. Any cables running to remote support equipment were routed through metal conduit and when possible passed through a ferrite clamp upon exiting the chamber.

Ambient Conditions:	Temperature:	20 °C
	Rel. Humidity:	37 %

Summary of Results

Run #	Test Performed	Limit	Result	Margin
1	CE, AC Power, 120V/60Hz	FCC 15.109 / FCC 15.209 / RSS 210	Pass	21.4dBµV @ 24.000MHz (-28.6dB)

Modifications Made During Testing

No modifications were made to the EUT during testing

Deviations From The Standard

No deviations were made from the requirements of the standard.

Client: Intel	Job Number: J70979
Model: 512an MMW	T-Log Number: T71040
Contact: Robert Paxman	Account Manager: Briggs / Eriksen
Standard: RSS 210 / FCC 15.247 DTS (Radiated)	Class: DTS

Run #1: AC Power Port Conducted Emissions, 0.15 - 30MHz, 120V/60Hz

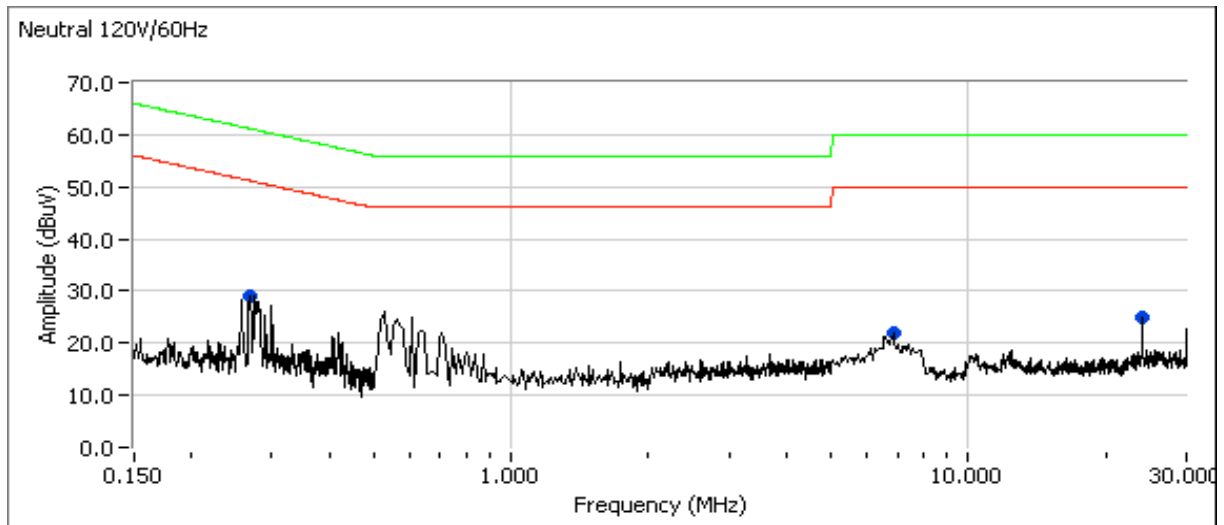
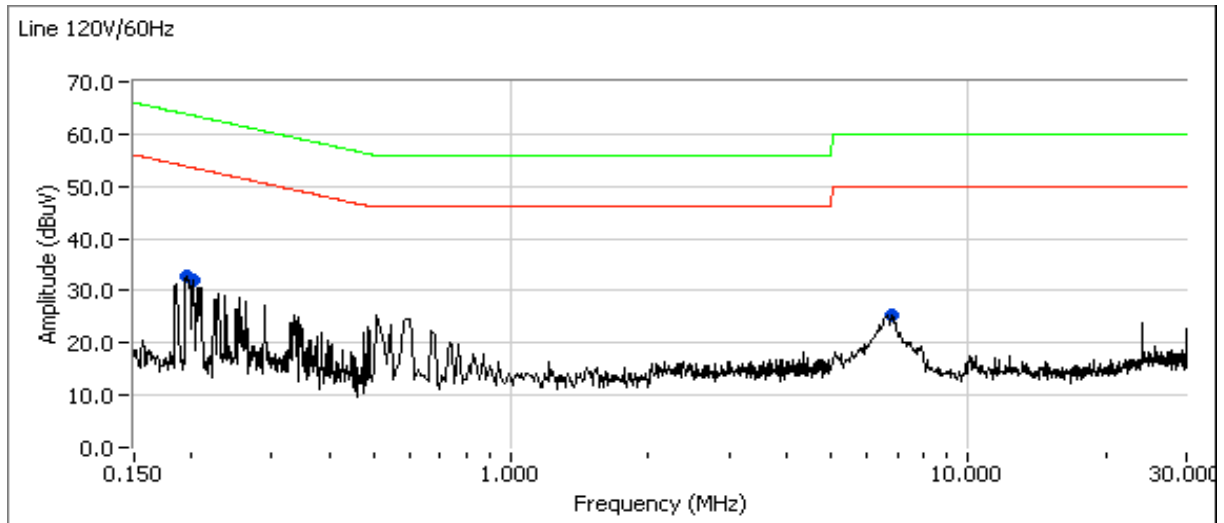

Run #1: AC Power Port Conducted Emissions, 0.15 - 30MHz, 120V/60Hz Continued Next Page...



EMC Test Data

Client:	Intel	Job Number:	J70979
Model:	512an MMW	T-Log Number:	T71040
Contact:	Robert Paxman	Account Manager:	Briggs / Eriksen
Standard:	RSS 210 / FCC 15.247 DTS (Radiated)	Class:	DTS

Preliminary peak readings captured during pre-scan (peak readings vs. average limit)

Frequency MHz	Level dB μ V	AC Line	FCC 15.109/15.209 Limit Margin		Detector QP/Ave	Comments
0.195	32.9	Line 1	53.8	-20.9	Peak	
0.201	31.9	Line 1	53.5	-21.6	Peak	
0.269	29.0	Neutral	51.2	-22.2	Peak	
6.801	25.5	Line 1	50.0	-24.5	Peak	
24.000	24.9	Neutral	50.0	-25.1	Peak	
6.826	21.9	Neutral	50.0	-28.1	Peak	

Final quasi-peak and average readings

Frequency MHz	Level dB μ V	AC Line	FCC 15.109/15.209 Limit Margin		Detector QP/Ave	Comments
24.000	21.4	Neutral	50.0	-28.6	AVG	
6.801	16.7	Line 1	50.0	-33.3	AVG	
24.000	23.4	Neutral	60.0	-36.6	QP	
0.195	26.0	Line 1	63.8	-37.8	QP	
6.801	22.2	Line 1	60.0	-37.8	QP	
0.201	25.4	Line 1	63.6	-38.2	QP	
6.826	10.5	Neutral	50.0	-39.5	AVG	
0.269	21.0	Neutral	61.1	-40.1	QP	
0.269	10.5	Neutral	51.1	-40.6	AVG	
0.195	10.9	Line 1	53.8	-42.9	AVG	
0.201	10.7	Line 1	53.6	-42.9	AVG	
6.826	15.4	Neutral	60.0	-44.6	QP	