



A D T

FCC TEST REPORT (WLAN)

REPORT NO.: RF120321C23-4

MODEL NO.: F-11D

FCC ID: HFS-IS3

RECEIVED: Mar. 21, 2012

TESTED: Apr. 04 ~ Apr. 28, 2012

ISSUED: May 08, 2012

APPLICANT: Quanta Computer Inc.

ADDRESS: No. 211, Wen Hwa 2nd Road, Kuei Shan Hsiang
Tao Yuan Hsien, Taiwan R.O.C.

ISSUED BY: Bureau Veritas Consumer Products Services
(H.K.) Ltd., Taoyuan Branch

LAB ADDRESS: No. 47, 14th Ling, Chia Pau Vil., Lin Kou Dist.,
New Taipei City, Taiwan (R.O.C.)

TEST LOCATION: No. 19, Hwa Ya 2nd Rd, Wen Hwa Tsuen, Kwei
Shan Hsiang, Taoyuan Hsien 333, Taiwan, R.O.C.

This test report consists of 58 pages in total. It may be duplicated completely for legal use with the approval of the applicant. It should not be reproduced except in full, without the written approval of our laboratory. The client should not use it to claim product certification, approval or endorsement by TAF or any government agency. The test results in the report only apply to the tested sample.





TABLE OF CONTENTS

RELEASE CONTROL RECORD.....	4
1. CERTIFICATION.....	5
2. SUMMARY OF TEST RESULTS	6
2.1 MEASUREMENT UNCERTAINTY	6
3. GENERAL INFORMATION.....	7
3.1 GENERAL DESCRIPTION OF EUT.....	7
3.2 DESCRIPTION OF TEST MODES.....	8
3.2.1 TEST MODE APPLICABILITY AND TESTED CHANNEL DETAIL.....	9
3.3 DESCRIPTION OF SUPPORT UNITS	11
3.3.1 CONFIGURATION OF SYSTEM UNDER TEST	11
3.4 GENERAL DESCRIPTION OF APPLIED STANDARDS	11
4. TEST TYPES AND RESULTS	12
4.1 RADIATED EMISSION AND BANDEDGE MEASUREMENT.....	12
4.1.1 LIMITS OF RADIATED EMISSION AND BANDEDGE MEASUREMENT	12
4.1.2 TEST INSTRUMENTS	13
4.1.3 TEST PROCEDURES	14
4.1.4 DEVIATION FROM TEST STANDARD	14
4.1.5 TEST SETUP	15
4.1.6 EUT OPERATING CONDITIONS	15
4.1.7 TEST RESULTS	16
4.2 CONDUCTED EMISSION MEASUREMENT	36
4.2.1 LIMITS OF CONDUCTED EMISSION MEASUREMENT.....	36
4.2.2 TEST INSTRUMENTS	36
4.2.3 TEST PROCEDURES	37
4.2.4 DEVIATION FROM TEST STANDARD	37
4.2.5 TEST SETUP	37
4.2.6 EUT OPERATING CONDITIONS	37
4.2.7 TEST RESULTS	38
4.3 6dB BANDWIDTH MEASUREMENT	40
4.3.1 LIMITS OF 6dB BANDWIDTH MEASUREMENT	40
4.3.2 TEST SETUP	40
4.3.3 TEST INSTRUMENTS	40
4.3.4 TEST PROCEDURE	40
4.3.5 DEVIATION FROM TEST STANDARD	40
4.3.6 EUT OPERATING CONDITIONS.....	40



4.3.7	TEST RESULTS	41
4.4	CONDUCTED OUTPUT POWER	42
4.4.1	LIMITS OF CONDUCTED OUTPUT POWER MEASUREMENT	42
4.4.2	TEST SETUP	42
4.4.3	TEST INSTRUMENTS	42
4.4.4	TEST PROCEDURES	42
4.4.5	DEVIATION FROM TEST STANDARD	42
4.4.6	EUT OPERATING CONDITIONS	42
4.4.7	TEST RESULTS	43
4.5	POWER SPECTRAL DENSITY MEASUREMENT	44
4.5.1	LIMITS OF POWER SPECTRAL DENSITY MEASUREMENT	44
4.5.2	TEST SETUP	44
4.5.3	TEST INSTRUMENTS	44
4.5.4	TEST PROCEDURE	44
4.5.5	DEVIATION FROM TEST STANDARD	44
4.5.6	EUT OPERATING CONDITION	44
4.5.7	TEST RESULTS	45
4.6	CONDUCTED OUT OF BAND EMISSION MEASUREMENT	48
4.6.1	LIMITS OF CONDUCTED OUT OF BAND EMISSION MEASUREMENT	48
4.6.2	TEST SETUP	48
4.6.3	TEST INSTRUMENTS	48
4.6.4	TEST PROCEDURE	48
4.6.5	DEVIATION FROM TEST STANDARD	49
4.6.6	EUT OPERATING CONDITION	49
4.6.7	TEST RESULTS	49
4.6.8	TEST RESULTS	50
5.	PHOTOGRAPHS OF THE TEST CONFIGURATION	56
6.	INFORMATION ON THE TESTING LABORATORIES	57
7.	APPENDIX A - MODIFICATIONS RECORDERS FOR ENGINEERING CHANGES TO THE EUT BY THE LAB	58



A D T

RELEASE CONTROL RECORD

ISSUE NO.	REASON FOR CHANGE	DATE ISSUED
RF120321C23-4	Original release	May 08, 2012



A D T

1. CERTIFICATION

PRODUCT: Smart Phone
MODEL NO.: F-11D
BRAND: Fujitsu
APPLICANT: Quanta Computer Inc.
TESTED: Apr. 04 ~ Apr. 28, 2012
TEST SAMPLE: Production Unit
STANDARDS: **FCC Part 15, Subpart C (Section 15.247)**
ANSI C63.10-2009

The above equipment (model: F-11D) has been tested by **Bureau Veritas Consumer Products Services (H.K.) Ltd., Taoyuan Branch**, and found compliance with the requirement of the above standards. The test record, data evaluation & Equipment Under Test (EUT) configurations represented herein are true and accurate accounts of the measurements of the sample's EMC characteristics under the conditions specified in this report.

PREPARED BY :  , **DATE** : May 08, 2012

Pettie Chen / Specialist

APPROVED BY :  , **DATE** : May 08, 2012

Gary Chang / Technical Manager



2. SUMMARY OF TEST RESULTS

The EUT has been tested according to the following specifications:

APPLIED STANDARD: FCC PART 15, SUBPART C (SECTION 15.247)			
STANDARD SECTION	TEST TYPE	RESULT	REMARK
15.207	AC Power Conducted Emission	PASS	Meet the requirement of limit. Minimum passing margin is -8.93dB at 0.16172MHz.
15.247(d) 15.209	Radiated Emissions	PASS	Meet the requirement of limit. Minimum passing margin is -0.22dB at 7386.00MHz.
15.247(d)	Band Edge Measurement	PASS	Meet the requirement of limit.
15.247(a)(2)	6dB bandwidth	PASS	Meet the requirement of limit.
15.247(b)	Conducted power	PASS	Meet the requirement of limit.
15.247(e)	Power Spectral Density	PASS	Meet the requirement of limit.
15.203	Antenna Requirement	PASS	No antenna connector is used.

2.1 MEASUREMENT UNCERTAINTY

Where relevant, the following measurement uncertainty levels have been estimated for tests performed on the EUT as specified in CISPR 16-4-2:

MEASUREMENT	FREQUENCY	UNCERTAINTY
Conducted emissions	9kHz~30MHz	2.44 dB
Radiated emissions	30MHz ~ 200MHz	2.93 dB
	200MHz ~1000MHz	2.95 dB
	1GHz ~ 18GHz	2.26 dB
	18GHz ~ 40GHz	1.94 dB

This uncertainty represents an expanded uncertainty expressed at approximately the 95% confidence level using a coverage factor of $k = 2$.



3. GENERAL INFORMATION

3.1 GENERAL DESCRIPTION OF EUT

EUT	Smart Phone
MODEL NO.	F-11D
POWER SUPPLY	5.0Vdc (adapter or host equipment) 3.8Vdc (battery)
MODULATION TYPE	CCK, DQPSK, DBPSK for DSSS 64QAM, 16QAM, QPSK, BPSK for OFDM
MODULATION TECHNOLOGY	DSSS, OFDM
TRANSFER RATE	802.11b: 11.0/ 5.5/ 2.0/ 1.0Mbps 802.11g: 54.0/ 48.0/ 36.0/ 24.0/ 18.0/ 12.0/ 9.0/ 6.0Mbps 802.11n: up to 72.2Mbps
OPERATING FREQUENCY	2412 ~ 2462MHz
NUMBER OF CHANNEL	11 for 802.11b, 802.11g, 802.11n (20MHz)
OUTPUT POWER	0.186W
ANTENNA TYPE	PIFA antenna with 1.5dBi gain
ANTENNA CONNECTOR	N/A
I/O PORTS	Refer to users' manual
DATA CABLE	Refer to Note as below
ACCESSORY DEVICES	Refer to Note as below

NOTE:

1. The EUT provides one completed transmitter and one receiver.

MODULATION MODE	TX FUNCTION
802.11b	1TX
802.11g	1TX
802.11n (20MHz)	1TX



2. The EUT's accessories listed as below.

AC Adapter (not for sale)	Brand Name	TPT
	Model Name	MII050100
	Power Rating	I/P:100-240Vac, 50-60Hz, 13~17VA; 0.5A O/P: 5Vdc, 1A
	DC Power Cord Type	1.23 meter non-shielded cable without ferrite core
Battery	Brand Name	Fujitsu
	Model Name	IS3
	Power Rating	3.8Vdc, 1520mAh, 5.78Wh
	Type	Li-ion
Camera (Front)	Brand Name	None
	Model Name	None
Camera (Back)	Brand Name	MCNEX
	Model Name	IS3_5M_AF MC520B-2DB1E0149

*The AC adapter is for support unit only.

3. The above EUT information is declared by manufacturer and for more detailed features description, please refer to the manufacturer's specifications or user's manual.

3.2 DESCRIPTION OF TEST MODES

11 channels are provided for 802.11b, 802.11g and 802.11n (20MHz):

CHANNEL	FREQUENCY	CHANNEL	FREQUENCY
1	2412MHz	7	2442MHz
2	2417MHz	8	2447MHz
3	2422MHz	9	2452MHz
4	2427MHz	10	2457MHz
5	2432MHz	11	2462MHz
6	2437MHz		

3.2.1 TEST MODE APPLICABILITY AND TESTED CHANNEL DETAIL

EUT CONFIGURE MODE	APPLICABLE TO				DESCRIPTION
	RE \geq 1G	RE<1G	PLC	APCM	
-	√	√	√	√	-

Where **RE \geq 1G**: Radiated Emission above 1GHz
RE<1G: Radiated Emission below 1GHz
PLC: Power Line Conducted Emission
APCM: Antenna Port Conducted Measurement

NOTE:

The EUT had been pre-tested on the positioned of each 3 axis. The worst case was found when positioned on **Y-plane**.

RADIATED EMISSION TEST (ABOVE 1GHz):

- Pre-Scan has been conducted to determine the worst-case mode from all possible combinations between available modulations, data rates and antenna ports (if EUT with antenna diversity architecture).
- Following channel(s) was (were) selected for the final test as listed below.

EUT CONFIGURE MODE	MODE	AVAILABLE CHANNEL	TESTED CHANNEL	MODULATION TECHNOLOGY	MODULATION TYPE	DATA RATE (Mbps)
-	802.11b	1 to 11	1, 6, 11	DSSS	DBPSK	1.0
-	802.11g	1 to 11	1, 6, 11	OFDM	BPSK	6.0
-	802.11n (20MHz)	1 to 11	1, 6, 11	OFDM	BPSK	7.2

RADIATED EMISSION TEST (BELOW 1GHz):

- Pre-Scan has been conducted to determine the worst-case mode from all possible combinations between available modulations, data rates and antenna ports (if EUT with antenna diversity architecture).
- Following channel(s) was (were) selected for the final test as listed below.

EUT CONFIGURE MODE	MODE	AVAILABLE CHANNEL	TESTED CHANNEL	MODULATION TECHNOLOGY	MODULATION TYPE	DATA RATE (Mbps)
-	802.11n (20MHz)	1 to 11	6	OFDM	BPSK	7.2

POWER LINE CONDUCTED EMISSION TEST:

- Pre-Scan has been conducted to determine the worst-case mode from all possible combinations between available modulations, data rates and antenna ports (if EUT with antenna diversity architecture).
- Following channel(s) was (were) selected for the final test as listed below.

EUT CONFIGURE MODE	MODE	AVAILABLE CHANNEL	TESTED CHANNEL	MODULATION TECHNOLOGY	MODULATION TYPE	DATA RATE (Mbps)
-	802.11n (20MHz)	1 to 11	6	OFDM	BPSK	7.2



BANDEDGE MEASUREMENT:

- Pre-Scan has been conducted to determine the worst-case mode from all possible combinations between available modulations, data rates and antenna ports (if EUT with antenna diversity architecture).
- Following channel(s) was (were) selected for the final test as listed below.

EUT CONFIGURE MODE	MODE	AVAILABLE CHANNEL	TESTED CHANNEL	MODULATION TECHNOLOGY	MODULATION TYPE	DATA RATE (Mbps)
-	802.11b	1 to 11	1, 11	DSSS	DBPSK	1.0
-	802.11g	1 to 11	1, 11	OFDM	BPSK	6.0
-	802.11n (20MHz)	1 to 11	1, 11	OFDM	BPSK	7.2

ANTENNA PORT CONDUCTED MEASUREMENT:

- This item includes all test value of each mode, but only includes spectrum plot of worst value of each mode.
- Pre-Scan has been conducted to determine the worst-case mode from all possible combinations between available modulations, data rates and antenna ports (if EUT with antenna diversity architecture).
- Following channel(s) was (were) selected for the final test as listed below.

EUT CONFIGURE MODE	MODE	AVAILABLE CHANNEL	TESTED CHANNEL	MODULATION TECHNOLOGY	MODULATION TYPE	DATA RATE (Mbps)
-	802.11b	1 to 11	1, 6, 11	DSSS	DBPSK	1.0
-	802.11g	1 to 11	1, 6, 11	OFDM	BPSK	6.0
-	802.11n (20MHz)	1 to 11	1, 6, 11	OFDM	BPSK	7.2

TEST CONDITION:

APPLICABLE TO	ENVIRONMENTAL CONDITIONS	INPUT POWER	TESTED BY
RE≥1G	25deg. C, 65%RH	120Vac, 60Hz	Kay Wu
RE<1G	25deg. C, 65%RH	120Vac, 60Hz	Kay Wu
PLC	25deg. C, 65%RH	120Vac, 60Hz	David Huang
APCM	22deg. C, 65%RH	120Vac, 60Hz	Kay Wu

3.3 DESCRIPTION OF SUPPORT UNITS

The EUT has been tested as an independent unit together with other necessary accessories or support units. The following support units or accessories were used to form a representative test configuration during the tests.

NO.	PRODUCT	BRAND	MODEL NO.	SERIAL NO.	FCC ID
1	Earphone	NA	NA	NA	NA

NO.	SIGNAL CABLE DESCRIPTION OF THE ABOVE SUPPORT UNITS
1	1.5m non-shielded cable

NOTE: All power cords of the above support units are non-shielded (1.8 m).

3.3.1 CONFIGURATION OF SYSTEM UNDER TEST

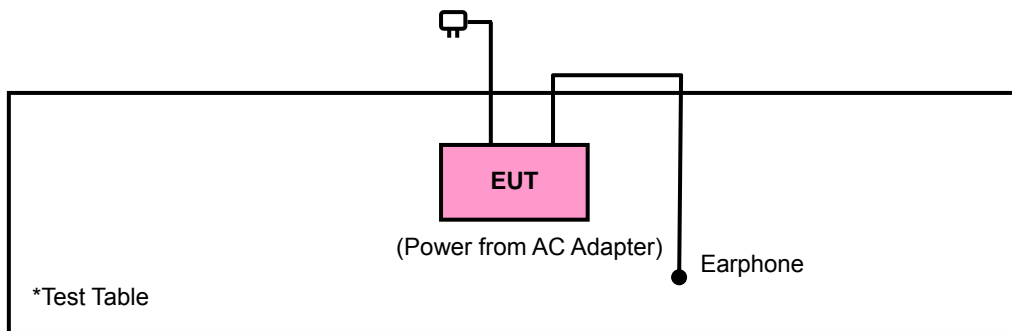

3.4 GENERAL DESCRIPTION OF APPLIED STANDARDS

The EUT is a RF Product. According to the specifications of the manufacturer, it must comply with the requirements of the following standards:

FCC Part 15, Subpart C (15.247)

ANSI C63.10-2009

558074 D01 DTS Meas Guidance v01

All test items have been performed and recorded as per the above standards.

NOTE: The EUT is also considered as a kind of computer peripheral, because the connection to computer is necessary for typical use. It has been verified to comply with the requirements of FCC Part 15, Subpart B, Class B (DoC). The test report has been issued separately.



4. TEST TYPES AND RESULTS

4.1 RADIATED EMISSION AND BANDEDGE MEASUREMENT

4.1.1 LIMITS OF RADIATED EMISSION AND BANDEDGE MEASUREMENT

Radiated emissions which fall in the restricted bands must comply with the radiated emission limits specified as below table. Other emissions shall be at least 20dB below the highest level of the desired power:

FREQUENCIES (MHz)	FIELD STRENGTH (microvolts/meter)	MEASUREMENT DISTANCE (meters)
0.009 ~ 0.490	2400/F(kHz)	300
0.490 ~ 1.705	24000/F(kHz)	30
1.705 ~ 30.0	30	30
30 ~ 88	100	3
88 ~ 216	150	3
216 ~ 960	200	3
Above 960	500	3

NOTE:

1. The lower limit shall apply at the transition frequencies.
2. Emission level (dBuV/m) = 20 log Emission level (uV/m).
3. For frequencies above 1000MHz, the field strength limits are based on average detector, however, the peak field strength of any emission shall not exceed the maximum permitted average limits, specified above by more than 20dB under any condition of modulation.



A D T

4.1.2 TEST INSTRUMENTS

DESCRIPTION & MANUFACTURER	MODEL NO.	SERIAL NO.	DATE OF CALIBRATION	DUE DATE OF CALIBRATION
Test Receiver Agilent	N9038A	MY51210203	Dec. 22, 2011	Dec. 21, 2012
Spectrum Analyzer ROHDE & SCHWARZ	FSU43	101261	Dec. 21, 2011	Dec. 20, 2012
BILOG Antenna SCHWARZBECK	VULB9168	9168-472	Dec. 20, 2011	Dec. 19, 2012
HORN Antenna SCHWARZBECK	BBHA 9120 D	9120D-969	Dec. 20, 2011	Dec. 19, 2012
HORN Antenna SCHWARZBECK	BBHA 9170	9170-480	Dec. 20, 2011	Dec. 19, 2012
Loop Antenna	HFH2-Z2	100070	Jan. 31, 2012	Jan. 30, 2014
Preamplifier EMCI	EMC 012645	980115	Dec. 30, 2011	Dec. 29, 2012
Preamplifier EMCI	EMC 330H	980112	Dec. 30, 2011	Dec. 29, 2012
RF signal cable HUBER+SUHNNER	SUCOFLEX 104	309219/4	Oct. 21, 2011	Oct. 20, 2012
RF signal cable HUBER+SUHNNER	SUCOFLEX 104	250130/4	Jan. 02, 2012	Jan. 01, 2013
RF signal cable Worken	RG-213	NA	Jan. 02, 2012	Jan. 01, 2013
Software	E3 6.120103	NA	NA	NA
Antenna Tower MF	MFA-440H	NA	NA	NA
Turn Table MF	MFT-201SS	NA	NA	NA
Antenna Tower & Turn Table Controller MF	MF-7802	NA	NA	NA
Mini-Circuits Power Splitter	ZN2PD-9G	NA	May 25, 2011	May 24, 2012
JFW 20dB attenuation	50HF-020-SMA	NA	NA	NA
High Speed Peak Power Meter	ML2495A	0824011	Aug. 04, 2011	Aug. 03, 2012
Power Sensor	MA2411B	0738171	Aug. 04, 2011	Aug. 03, 2012

- NOTE:**
1. The calibration interval of the above test instruments except loop antenna is 12 months and the calibrations are traceable to NML/ROC and NIST/USA.
 2. The calibration interval of loop antenna is 24 months and the calibrations are traceable to NML/ROC and NIST/USA.
 3. The test was performed in HwaYa Chamber 9.
 4. The horn antenna and HP preamplifier (model: 8449B) are used only for the measurement of emission frequency above 1GHz if tested.
 5. The FCC Site Registration No. is 460141.
 6. The IC Site Registration No. is IC 7450F-4.



4.1.3 TEST PROCEDURES

- a. The EUT was placed on the top of a rotating table 0.8 meters above the ground at a 3 meters semi-anechoic chamber. The table was rotated 360 degrees to determine the position of the highest radiation.
- b. The EUT was set 3 meters away from the interference-receiving antenna, which was mounted on the top of a variable-height antenna tower.
- c. The antenna is a broadband antenna, and its height is varied from one meter to four meters above the ground to determine the maximum value of the field strength. Both horizontal and vertical polarizations of the antenna are set to make the measurement.
- d. For each suspected emission, the EUT was arranged to its worst case and then the antenna was tuned to heights from 1 meter to 4 meters and the rotatable table was turned from 0 degrees to 360 degrees to find the maximum reading.
- e. The test-receiver system was set to Peak Detect Function and Specified Bandwidth with Maximum Hold Mode.
- f. If the emission level of the EUT in peak mode was lower than the limit specified, then testing could be stopped and the peak values of the EUT would be reported. Otherwise the emissions would be re-tested one by one using peak, quasi-peak or average method as specified and then reported in a data sheet.

NOTE:

1. The resolution bandwidth and video bandwidth of test receiver/spectrum analyzer is 120kHz for Quasi-peak detection at frequency below 1GHz.
2. The resolution bandwidth of test receiver/spectrum analyzer is 100kHz and video bandwidth is 300kHz for Peak detection at frequency above 1GHz.
3. The resolution bandwidth of test receiver/spectrum analyzer is 1MHz and the video bandwidth is 1kHz for Average detection (AV) at frequency above 1GHz.
4. All modes of operation were investigated and the worst-case emissions are reported.

4.1.4 DEVIATION FROM TEST STANDARD

No deviation.

4.1.5 TEST SETUP

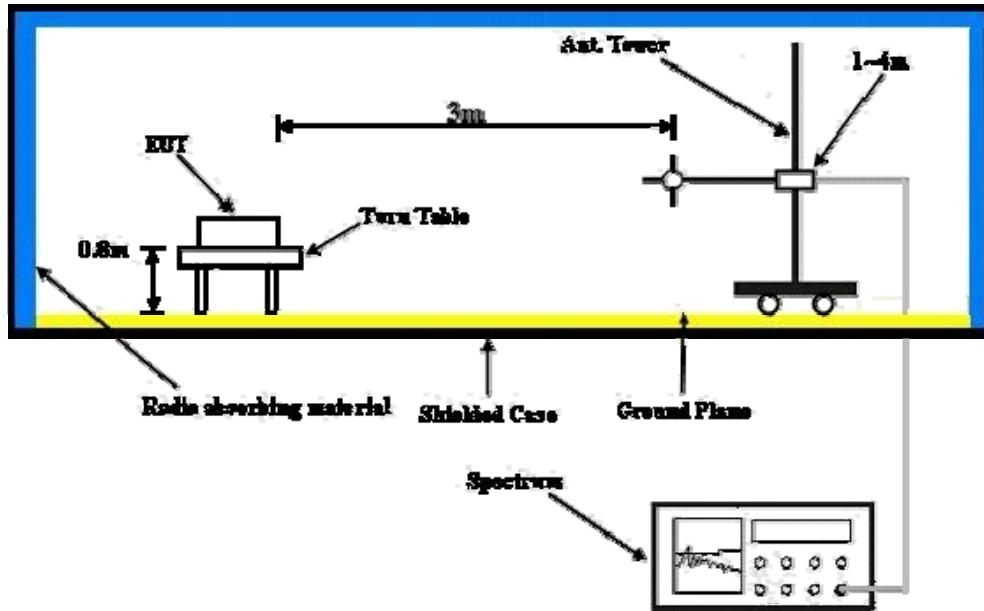

For the actual test configuration, please refer to the attached file (Test Setup Photo).

4.1.6 EUT OPERATING CONDITIONS

Set the EUT under transmission condition continuously at specific channel frequency.



A D T

4.1.7 TEST RESULTS

ABOVE 1GHz:



Bureau Veritas Consumer Products Services Ltd., Taoyuan Branch

A D T

Data: 15

Date: 2012-04-27

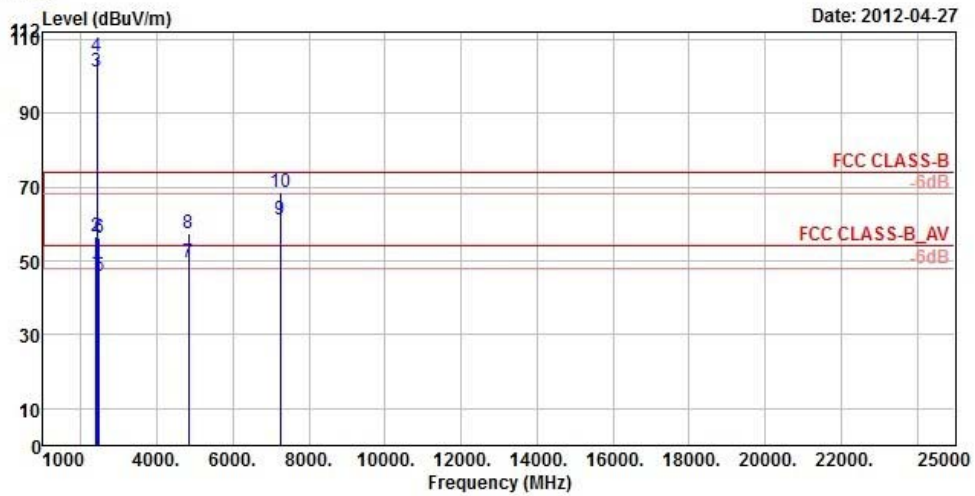

Site : 966 Chamber 5
 Condition : FCC CLASS-B 3m ANT_1G~18G_HF HORIZONTAL
 Brand/Model: F-11D
 Remark : 11B Tx CH01
 Tested by : Kay Wu
 Temperature : 25°C
 Humidity : 65%
 Plane : Y
 Power : 15
 Date : 11M

	Freq	Level	Read Level	Limit Line	OverLimit	Antenna Factor	Cable Loss	Preamp Factor	A/Pos	T/Pos	Remark
	MHz	dBuV/m	dBuV	dBuV/m	dB	dB/m	dB	dB	cm	deg	
1	2390.00	46.64	52.03	54.00	-7.36	27.26	4.87	37.52	104	156	Average
2	2390.00	56.46	61.85	74.00	-17.54	27.26	4.87	37.52	104	156	Peak
3 pp	2412.00	101.42	106.76	54.00	47.42	27.31	4.87	37.52	104	156	Average
4 pk	2412.00	105.53	110.87	74.00	31.53	27.31	4.87	37.52	104	156	Peak
5	2483.50	46.03	50.93	54.00	-7.97	27.50	4.92	37.32	104	156	Average
6	2483.50	56.26	61.16	74.00	-17.74	27.50	4.92	37.32	104	156	Peak
7 !	4824.00	49.61	63.57	54.00	-4.39	31.42	7.70	53.08	100	88	Average
8	4824.00	57.35	71.31	74.00	-16.65	31.42	7.70	53.08	100	88	Peak
9 *	7236.00	61.30	67.69	81.42	-20.12	36.05	9.57	52.01	121	287	Average
10 !	7236.00	68.56	74.95	85.53	-16.97	36.05	9.57	52.01	121	287	Peak

NOTE: Item 3, 4 were fundamental frequency.



A D T



Bureau Veritas Consumer Products Services Ltd., Taoyuan Branch

A D T

Data: 16

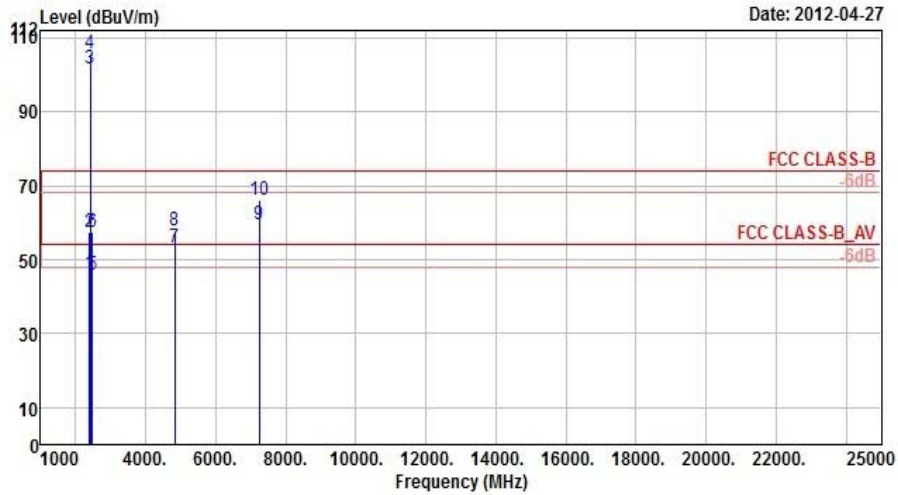

Site : 966 Chamber 5
 Condition : FCC CLASS-B 3m ANT_1G~18G_HF VERTICAL
 Brand/Model: F-11D
 Remark : 11B Tx CH01
 Tested by : Kay Wu
 Temperature : 25°C
 Humidity : 65%
 Plane : Y
 Power : 15
 Date : 11M

	Read	Limit	OverAntenna	Cable	Preamp	A/Pos	T/Pos			
	Level	Line	Limit	Loss	Factor	cm	deg	Remark		
	Freq	Level	Level	Factor	Factor	cm	deg			
	MHz	dBuV/m	dBuV	dB	dB/m	dB	dB	cm	deg	
1	2390.00	46.13	51.52	54.00	-7.87	27.26	4.87	37.52	119	222 Average
2	2390.00	57.55	62.94	74.00	-16.45	27.26	4.87	37.52	119	222 Peak
3 pp	2412.00	101.77	107.11	54.00	47.77	27.31	4.87	37.52	119	222 Average
4 pk	2412.00	105.86	111.20	74.00	31.86	27.31	4.87	37.52	119	222 Peak
5	2483.50	45.99	50.89	54.00	-8.01	27.50	4.92	37.32	119	222 Average
6	2483.50	57.52	62.42	74.00	-16.48	27.50	4.92	37.32	119	222 Peak
7 !	4824.00	53.30	67.26	54.00	-0.70	31.42	7.70	53.08	100	137 Average
8	4824.00	57.96	71.92	74.00	-16.04	31.42	7.70	53.08	100	137 Peak
9 *	7236.00	59.60	65.99	81.77	-22.17	36.05	9.57	52.01	100	85 Average
10	7236.00	66.31	72.70	85.86	-19.55	36.05	9.57	52.01	100	85 Peak

NOTE: Item 3, 4 were fundamental frequency.



A D T



Bureau Veritas Consumer Products Services Ltd., Taoyuan Branch

A D T

Data: 15

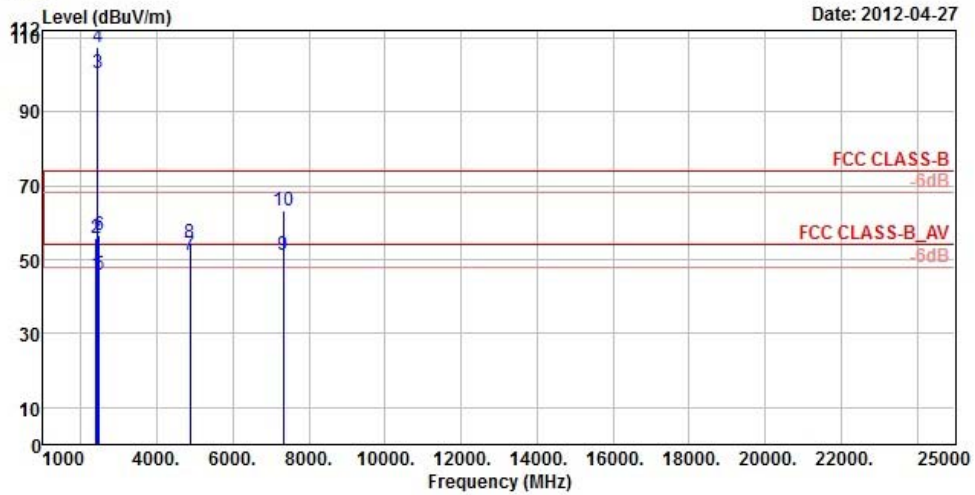

Site : 966 Chamber 5
 Condition : FCC CLASS-B 3m ANT_1G~18G_HF HORIZONTAL
 Brand/Model: F-11D
 Remark : 11B Tx CH06
 Tested by : Kay Wu
 Temperature : 25°C
 Humidity : 65%
 Plane : Y
 Power : 15
 Date : 11M

	Freq	Level	Read Level	Limit Line	OverLimit	Antenna Factor	Cable Loss	Preamp Factor	A/Pos	T/Pos	Remark
	MHz	dBuV/m	dBuV	dBuV/m	dB	dB/m	dB	dB	cm	deg	
1	2390.00	45.82	51.21	54.00	-8.18	27.26	4.87	37.52	125	196	Average
2	2390.00	55.99	61.38	74.00	-18.01	27.26	4.87	37.52	125	196	Peak
3 pp	2437.00	100.47	105.64	54.00	46.47	27.40	4.89	37.46	125	196	Average
4 pk	2437.00	107.44	112.61	74.00	33.44	27.40	4.89	37.46	125	196	Peak
5	2483.50	45.99	50.89	54.00	-8.01	27.50	4.92	37.32	125	196	Average
6	2483.50	56.75	61.65	74.00	-17.25	27.50	4.92	37.32	125	196	Peak
7 !	4874.00	51.08	64.88	54.00	-2.92	31.53	7.72	53.05	100	236	Average
8	4874.00	54.71	68.51	74.00	-19.29	31.53	7.72	53.05	100	236	Peak
9 !	7311.00	51.16	57.21	54.00	-2.84	36.22	9.58	51.85	100	107	Average
10	7311.00	63.13	69.18	74.00	-10.87	36.22	9.58	51.85	100	107	Peak

NOTE: Item 3, 4 were fundamental frequency.



A D T



Bureau Veritas Consumer Products Services Ltd., Taoyuan Branch

A D T

Data: 16

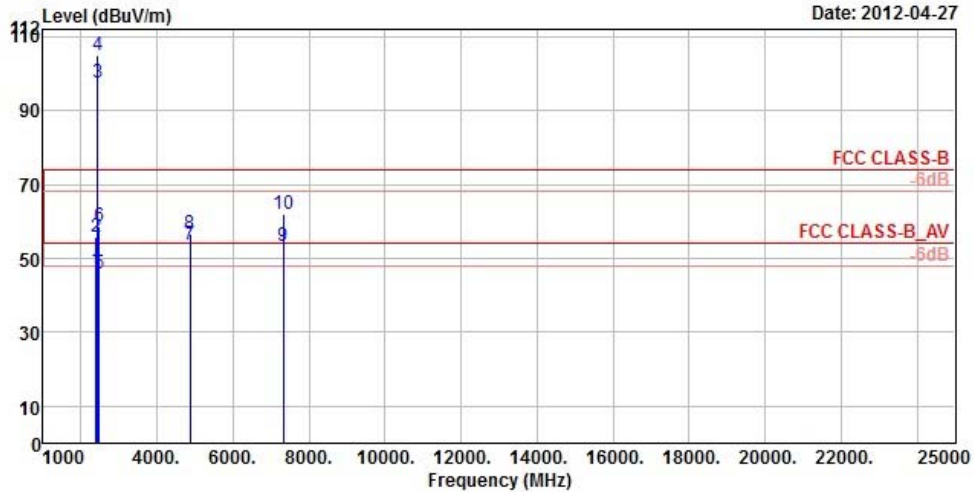

Site : 966 Chamber 5
 Condition : FCC CLASS-B 3m ANT_1G~18G_HF VERTICAL
 Brand/Model: F-11D
 Remark : 11B Tx CH06
 Tested by : Kay Wu
 Temperature : 25°C
 Humidity : 65%
 Plane : Y
 Power : 15
 Date : 11M

	Freq	Level	Read Level	Limit Line	OverLimit	Antenna Factor	Cable Loss	Preamp Factor	A/Pos	T/Pos	Remark
	MHz	dBuV/m	dBuV	dBuV/m	dB	dB/m	dB	dB	cm	deg	
1	2390.00	46.69	52.08	54.00	-7.31	27.26	4.87	37.52	140	229	Average
2	2390.00	55.87	61.26	74.00	-18.13	27.26	4.87	37.52	140	229	Peak
3 pp	2437.00	97.39	102.56	54.00	43.39	27.40	4.89	37.46	140	229	Average
4 pk	2437.00	104.93	110.10	74.00	30.93	27.40	4.89	37.46	140	229	Peak
5	2483.50	45.67	50.57	54.00	-8.33	27.50	4.92	37.32	140	229	Average
6	2483.50	58.49	63.39	74.00	-15.51	27.50	4.92	37.32	140	229	Peak
7 !	4874.00	53.64	67.44	54.00	-0.36	31.53	7.72	53.05	100	20	Average
8	4874.00	56.77	70.57	74.00	-17.23	31.53	7.72	53.05	100	20	Peak
9 !	7311.00	53.36	59.41	54.00	-0.64	36.22	9.58	51.85	100	321	Average
10	7311.00	62.07	68.12	74.00	-11.93	36.22	9.58	51.85	100	321	Peak

NOTE: Item 3, 4 were fundamental frequency.



A D T



Bureau Veritas Consumer Products Services Ltd., Taoyuan Branch

A D T

Data: 15

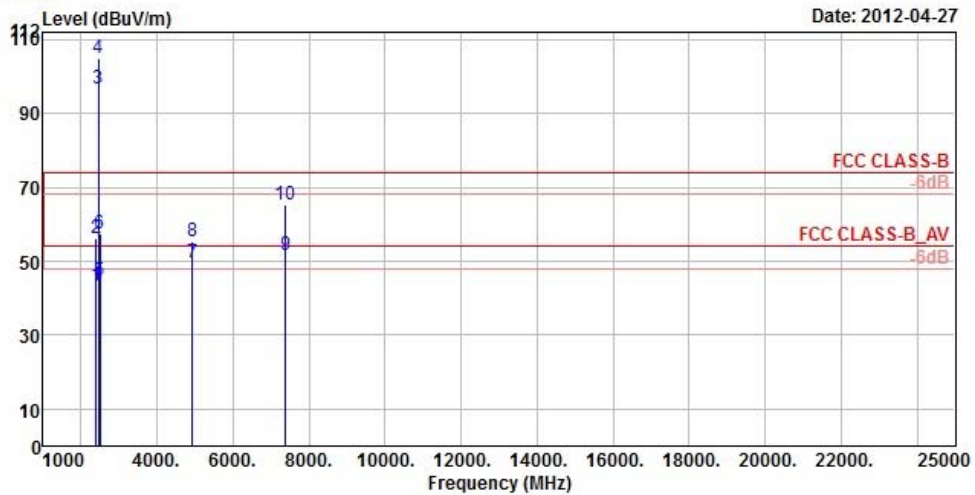

Site : 966 Chamber 5
 Condition : FCC CLASS-B 3m ANT_1G~18G_HF HORIZONTAL
 Brand/Model: F-11D
 Remark : 11B Tx CH11
 Tested by : Kay Wu
 Temperature : 25°C
 Humidity : 65%
 Plane : Y
 Power : 13
 Date : 11M

	Freq	Level	Read Level	Limit Line	OverLimit	Antenna Factor	Cable Loss	Preamp Factor	A/Pos	T/Pos	Remark
	MHz	dBuV/m	dBuV	dBuV/m	dB	dB/m	dB	dB	cm	deg	
1	2388.00	43.20	49.21	54.00	-10.80	27.26	4.23	37.50	101	40	Average
2	2388.00	56.11	62.12	74.00	-17.89	27.26	4.23	37.50	101	40	Peak
3 pp	2462.00	96.80	102.47	54.00	42.80	27.45	4.27	37.39	101	40	Average
4 pk	2462.00	105.16	110.83	74.00	31.16	27.45	4.27	37.39	101	40	Peak
5	2492.00	44.78	50.19	54.00	-9.22	27.55	4.29	37.25	101	40	Average
6	2492.00	57.31	62.72	74.00	-16.69	27.55	4.29	37.25	101	40	Peak
7 !	4924.00	49.57	63.23	54.00	-4.43	31.64	7.73	53.03	100	27	Average
8	4924.00	55.39	69.05	74.00	-18.61	31.64	7.73	53.03	100	27	Peak
9 !	7386.00	51.74	57.19	54.00	-2.26	36.43	9.72	51.60	100	184	Average
10	7386.00	65.39	70.84	74.00	-8.61	36.43	9.72	51.60	100	184	Peak

NOTE: Item 3, 4 were fundamental frequency.



A D T



Bureau Veritas Consumer Products Services Ltd., Taoyuan Branch

A D T

Data: 16

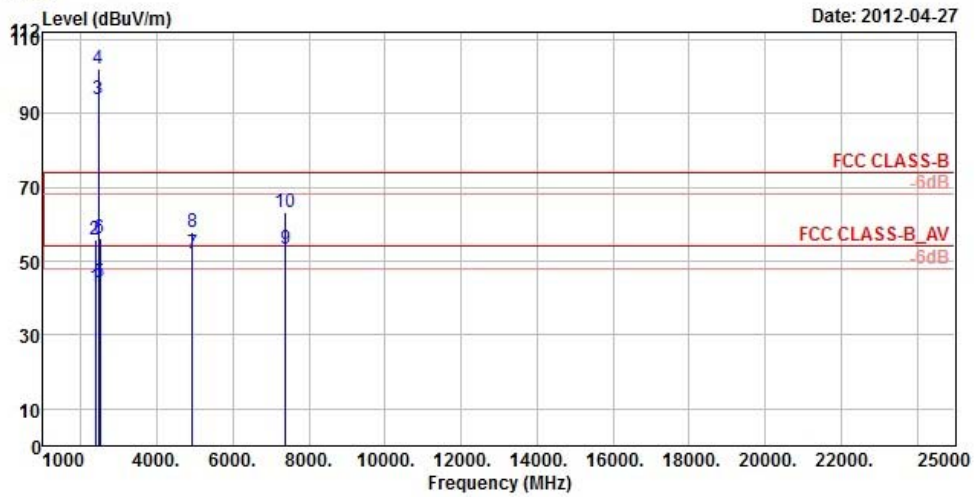

Site : 966 Chamber 5
 Condition : FCC CLASS-B 3m ANT_1G~18G_HF VERTICAL
 Brand/Model: F-11D
 Remark : 11B Tx CH11
 Tested by : Kay Wu
 Temperature : 25°C
 Humidity : 65%
 Plane : Y
 Power : 13
 Date : 11M

	Freq	Level	Read Level	Limit Line	OverLimit	Antenna Factor	Cable Loss	Preamp Factor	A/Pos	T/Pos	Remark
	MHz	dBuV/m	dBuV	dBuV/m	dB	dB/m	dB	dB	cm	deg	
1	2364.00	43.03	49.16	54.00	-10.97	27.16	4.20	37.49	104	249	Average
2	2364.00	55.97	62.10	74.00	-18.03	27.16	4.20	37.49	104	249	Peak
3 pp	2462.00	93.98	99.65	54.00	39.98	27.45	4.27	37.39	104	249	Average
4 pk	2462.00	102.03	107.70	74.00	28.03	27.45	4.27	37.39	104	249	Peak
5	2498.00	44.08	49.49	54.00	-9.92	27.55	4.29	37.25	104	249	Average
6	2498.00	56.24	61.65	74.00	-17.76	27.55	4.29	37.25	104	249	Peak
7 !	4924.00	51.87	65.53	54.00	-2.13	31.64	7.73	53.03	100	197	Average
8	4924.00	57.84	71.50	74.00	-16.16	31.64	7.73	53.03	100	197	Peak
9 !	7386.00	53.28	58.73	54.00	-0.72	36.43	9.72	51.60	100	284	Average
10	7386.00	63.35	68.80	74.00	-10.65	36.43	9.72	51.60	100	284	Peak

NOTE: Item 3, 4 were fundamental frequency.



A D T



Bureau Veritas Consumer Products Services Ltd., Taoyuan Branch

A D T

Data: 17

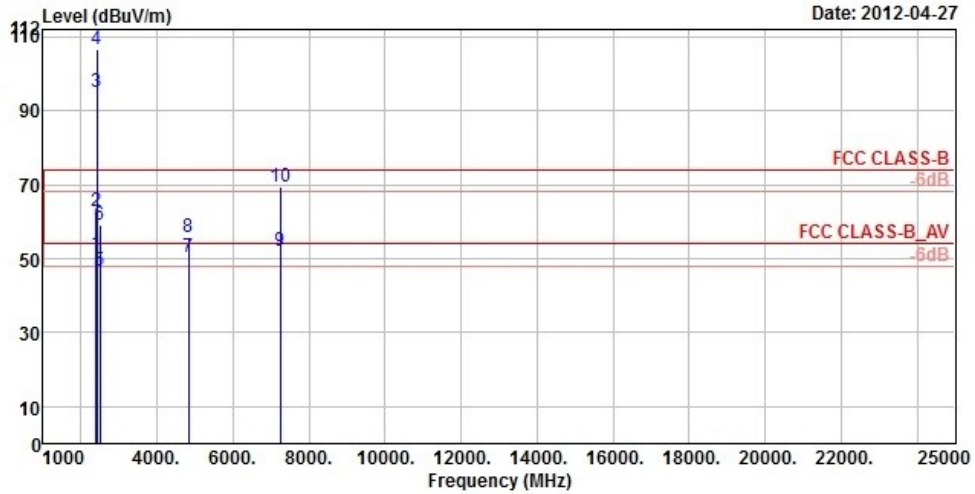

Site : 966 Chamber 5
 Condition : FCC CLASS-B 3m ANT_1G~18G_HF HORIZONTAL
 Brand/Model: F-11D
 Remark : 11G Tx CH01
 Tested by : Kay Wu
 Temperature : 25°C
 Humidity : 65%
 Plane : Y
 Power : 15
 Date : 6M

	Freq	Level	Read Level	Limit Line	OverLimit	Antenna Factor	Cable Loss	Preamp Factor	A/Pos	T/Pos	Remark
	MHz	dBuV/m	dBuV	dBuV/m	dB	dB/m	dB	dB	cm	deg	
1 !	2390.00	51.15	56.54	54.00	-2.85	27.26	4.87	37.52	128	123	Average
2	2390.00	62.77	68.16	74.00	-11.23	27.26	4.87	37.52	128	123	Peak
3 pp	2412.00	95.10	100.44	54.00	41.10	27.31	4.87	37.52	128	123	Average
4 pk	2412.00	106.50	111.84	74.00	32.50	27.31	4.87	37.52	128	123	Peak
5	2486.00	46.64	51.54	54.00	-7.36	27.50	4.92	37.32	128	123	Average
6	2486.00	59.15	64.05	74.00	-14.85	27.50	4.92	37.32	128	123	Peak
7 !	4824.00	50.28	64.24	54.00	-3.72	31.42	7.70	53.08	100	195	Average
8	4824.00	55.63	69.59	74.00	-18.37	31.42	7.70	53.08	100	195	Peak
9 !	7236.00	52.16	58.55	75.10	-22.94	36.05	9.57	52.01	100	285	Average
10 !	7236.00	69.60	75.99	86.50	-16.90	36.05	9.57	52.01	100	285	Peak

NOTE: Item 3, 4 were fundamental frequency.



A D T



Bureau Veritas Consumer Products Services Ltd., Taoyuan Branch

A D T

Data: 18

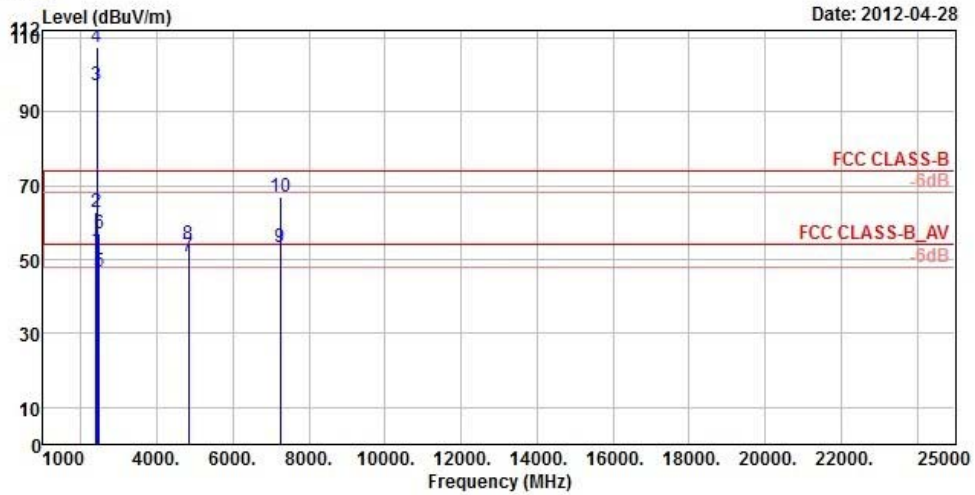

Site : 966 Chamber 5
 Condition : FCC CLASS-B 3m ANT_1G~18G_HF VERTICAL
 Brand/Model: F-11D
 Remark : 11G Tx CH01
 Tested by : Kay Wu
 Temperature : 25°C
 Humidity : 65%
 Plane : Y
 Power : 15
 Date : 6M

	Freq	Level	Read Level	Limit Line	OverLimit	Antenna Factor	Cable Loss	Preamp Factor	A/Pos	T/Pos	Remark
	MHz	dBuV/m	dBuV	dBuV/m	dB	dB/m	dB	dB	cm	deg	
1 !	2390.00	52.42	57.81	54.00	-1.58	27.26	4.87	37.52	118	224	Average
2	2390.00	62.68	68.07	74.00	-11.32	27.26	4.87	37.52	118	224	Peak
3 pp	2412.00	97.29	102.63	54.00	43.29	27.31	4.87	37.52	118	224	Average
4 pk	2412.00	107.37	112.71	74.00	33.37	27.31	4.87	37.52	118	224	Peak
5	2483.50	46.71	51.61	54.00	-7.29	27.50	4.92	37.32	118	224	Average
6	2483.50	57.15	62.05	74.00	-16.85	27.50	4.92	37.32	118	224	Peak
7 !	4824.00	51.04	65.00	54.00	-2.96	31.42	7.70	53.08	100	197	Average
8	4824.00	54.07	68.03	74.00	-19.93	31.42	7.70	53.08	100	197	Peak
9 !	7236.00	53.36	59.75	77.29	-23.93	36.05	9.57	52.01	110	147	Average
10	7236.00	66.80	73.19	87.37	-20.57	36.05	9.57	52.01	110	147	Peak

NOTE: Item 3, 4 were fundamental frequency.



A D T



Bureau Veritas Consumer Products Services Ltd., Taoyuan Branch

A D T

Data: 15

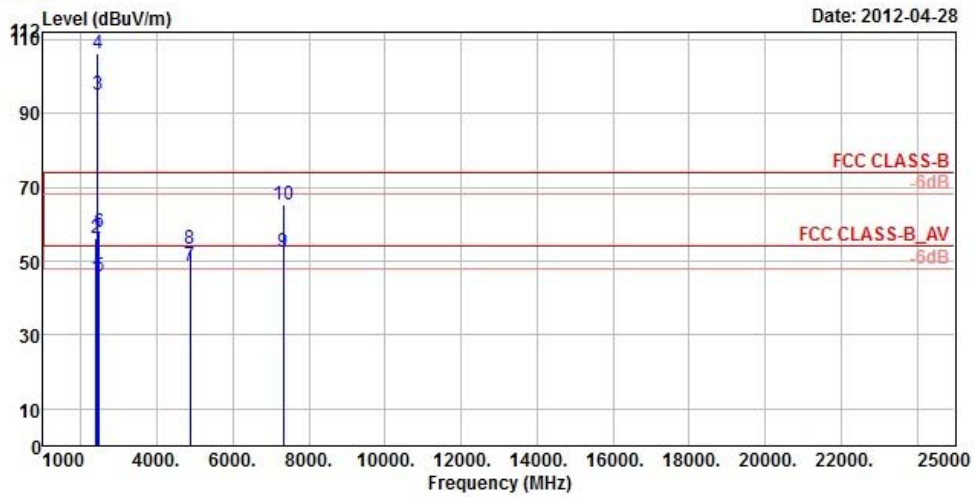

Site : 966 Chamber 5
 Condition : FCC CLASS-B 3m ANT_1G~18G_HF HORIZONTAL
 Brand/Model: F-11D
 Remark : 11G Tx CH06
 Tested by : Kay Wu
 Temperature : 25°C
 Humidity : 65%
 Plane : Y
 Power : 13
 Date : 6M

	Freq	Level	Read Level	Limit Line	OverLimit	Antenna Factor	Cable Loss	Preamp Factor	A/Pos	T/Pos	Remark
	MHz	dBuV/m	dBuV	dBuV/m	dB	dB/m	dB	dB	cm	deg	
1	2390.00	45.42	50.81	54.00	-8.58	27.26	4.87	37.52	120	232	Average
2	2390.00	56.35	61.74	74.00	-17.65	27.26	4.87	37.52	120	232	Peak
3 pp	2437.00	95.12	100.29	54.00	41.12	27.40	4.89	37.46	120	232	Average
4 pk	2437.00	106.21	111.38	74.00	32.21	27.40	4.89	37.46	120	232	Peak
5	2483.50	45.96	50.86	54.00	-8.04	27.50	4.92	37.32	120	232	Average
6	2483.50	57.90	62.80	74.00	-16.10	27.50	4.92	37.32	120	232	Peak
7 !	4874.00	48.75	62.55	54.00	-5.25	31.53	7.72	53.05	100	107	Average
8	4874.00	53.31	67.11	74.00	-20.69	31.53	7.72	53.05	100	107	Peak
9 !	7311.00	52.36	58.41	54.00	-1.64	36.22	9.58	51.85	100	58	Average
10	7311.00	65.39	71.31	74.00	-8.61	36.22	9.63	51.77	100	58	Peak

NOTE: Item 3, 4 were fundamental frequency.



A D T



Bureau Veritas Consumer Products Services Ltd., Taoyuan Branch

A D T

Data: 16

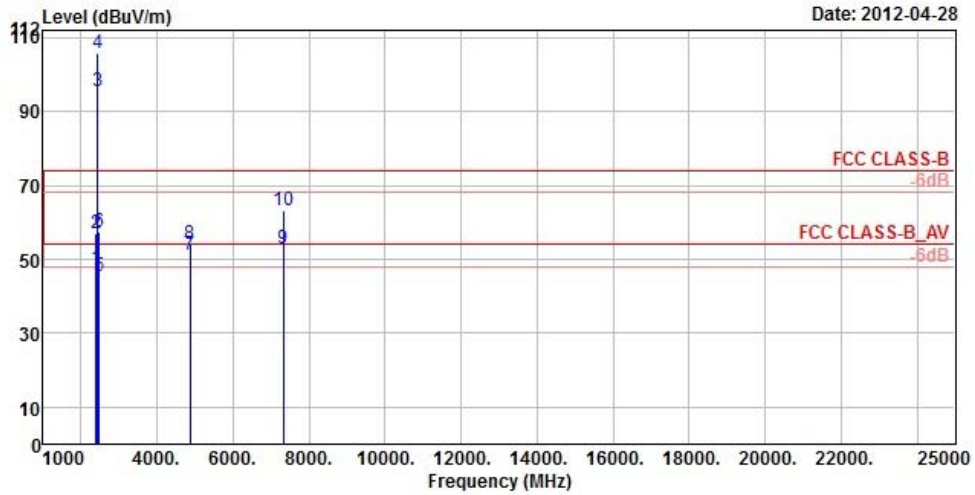

Site : 966 Chamber 5
 Condition : FCC CLASS-B 3m ANT_1G~18G_HF VERTICAL
 Brand/Model: F-11D
 Remark : 11G Tx CH06
 Tested by : Kay Wu
 Temperature : 25°C
 Humidity : 65%
 Plane : Y
 Power : 13
 Date : 6M

	Freq	Level	Read Level	Limit Line	OverLimit	Antenna Factor	Cable Loss	Preamp Factor	A/Pos	T/Pos	Remark
	MHz	dBuV/m	dBuV	dBuV/m	dB	dB/m	dB	dB	cm	deg	
1	2390.00	47.49	52.88	54.00	-6.51	27.26	4.87	37.52	135	169	Average
2	2390.00	56.88	62.27	74.00	-17.12	27.26	4.87	37.52	135	169	Peak
3 pp	2437.00	95.44	100.61	54.00	41.44	27.40	4.89	37.46	135	169	Average
4 pk	2437.00	105.64	110.81	74.00	31.64	27.40	4.89	37.46	135	169	Peak
5	2483.50	45.62	50.52	54.00	-8.38	27.50	4.92	37.32	135	169	Average
6	2483.50	57.27	62.17	74.00	-16.73	27.50	4.92	37.32	135	169	Peak
7 !	4874.00	51.45	65.25	54.00	-2.55	31.53	7.72	53.05	100	197	Average
8	4874.00	53.94	67.74	74.00	-20.06	31.53	7.72	53.05	100	197	Peak
9 !	7311.00	52.87	58.92	54.00	-1.13	36.22	9.58	51.85	102	57	Average
10	7311.00	63.22	69.27	74.00	-10.78	36.22	9.58	51.85	102	57	Peak

NOTE: Item 3, 4 were fundamental frequency.



A D T



Bureau Veritas Consumer Products Services Ltd., Taoyuan Branch

A D T

Data: 17

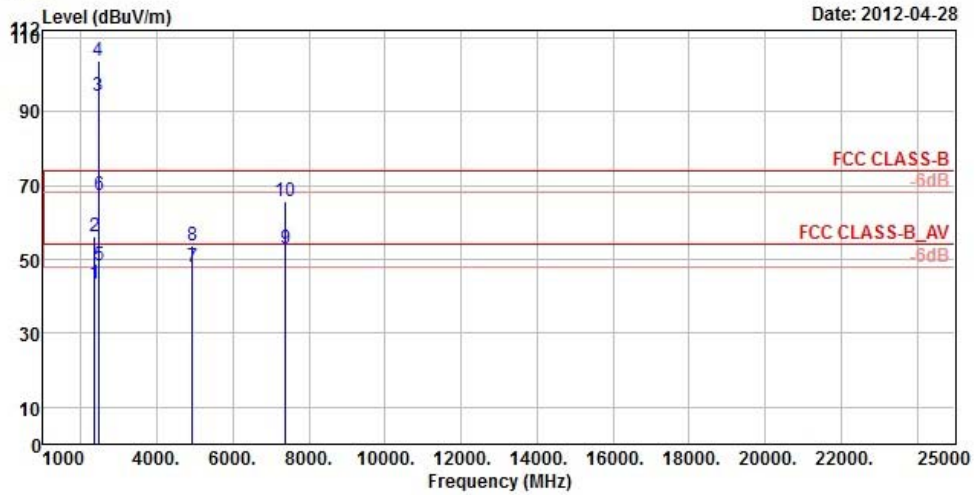

Site : 966 Chamber 5
 Condition : FCC CLASS-B 3m ANT_1G~18G_HF HORIZONTAL
 Brand/Model: F-11D
 Remark : 11G Tx CH11
 Tested by : Kay Wu
 Temperature : 25°C
 Humidity : 65%
 Plane : Y
 Power : 13
 Date : 6M

	Freq	Level	Read Level	Limit Line	OverLimit	Antenna Factor	Cable Loss	Preamp Factor	A/Pos	T/Pos	Remark
	MHz	dBuV/m	dBuV	dBuV/m	dB	dB/m	dB	dB	cm	deg	
1	2344.00	43.28	49.46	54.00	-10.72	27.11	4.20	37.49	101	41	Average
2	2344.00	56.18	62.36	74.00	-17.82	27.11	4.20	37.49	101	41	Peak
3 pp	2462.00	94.36	100.03	54.00	40.36	27.45	4.27	37.39	101	41	Average
4 pk	2462.00	103.64	109.31	74.00	29.64	27.45	4.27	37.39	101	41	Peak
5 !	2483.85	48.44	53.98	54.00	-5.56	27.50	4.28	37.32	101	41	Average
6	2483.85	67.36	72.90	74.00	-6.64	27.50	4.28	37.32	101	41	Peak
7	4924.00	47.87	61.53	54.00	-6.13	31.64	7.73	53.03	100	312	Average
8	4924.00	53.79	67.45	74.00	-20.21	31.64	7.73	53.03	100	312	Peak
9 !	7386.00	52.77	58.22	54.00	-1.23	36.43	9.72	51.60	128	77	Average
10	7386.00	65.90	71.35	74.00	-8.10	36.43	9.72	51.60	128	77	Peak

NOTE: Item 3, 4 were fundamental frequency.



A D T



Bureau Veritas Consumer Products Services Ltd., Taoyuan Branch

A D T

Data: 18

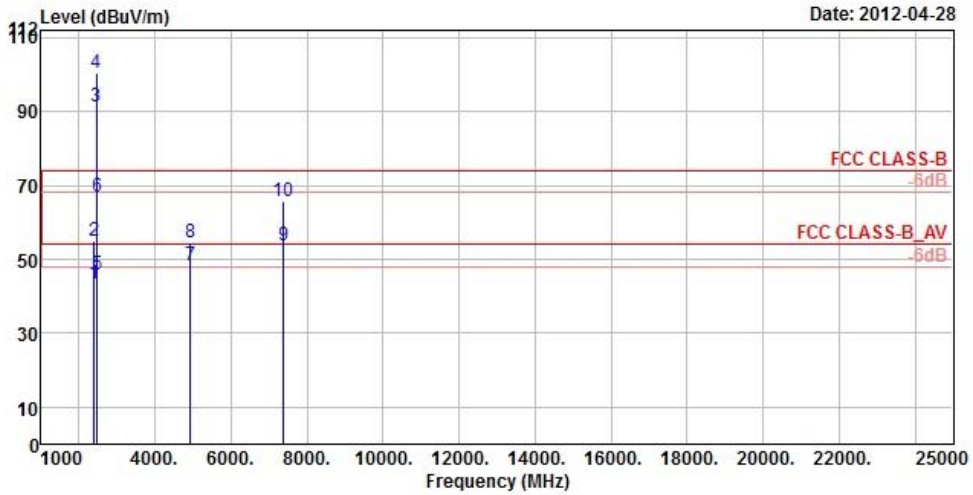

Site : 966 Chamber 5
Condition : FCC CLASS-B 3m ANT_1G~18G_HF VERTICAL
Brand/Model: F-11D
Remark : 11G Tx CH11
Tested by : Kay Wu
Temperature : 25°C
Humidity : 65%
Plane : Y
Power : 13
Date : 6M

	Freq	Level	Read Level	Limit Line	OverLimit	Antenna Factor	Cable Loss	Preamp Factor	A/Pos	T/Pos	Remark
	MHz	dBuV/m	dBuV	dBuV/m	dB	dB/m	dB	dB	cm	deg	
1	2390.00	43.22	49.23	54.00	-10.78	27.26	4.25	37.52	156	111	Average
2	2390.00	54.91	60.92	74.00	-19.09	27.26	4.25	37.52	156	111	Peak
3 pp	2462.00	91.50	97.17	54.00	37.50	27.45	4.27	37.39	156	111	Average
4 pk	2462.00	100.24	105.91	74.00	26.24	27.45	4.27	37.39	156	111	Peak
5	2483.66	46.02	51.56	54.00	-7.98	27.50	4.28	37.32	156	111	Average
6	2483.66	67.00	72.54	74.00	-7.00	27.50	4.28	37.32	156	111	Peak
7 !	4924.00	48.47	62.13	54.00	-5.53	31.64	7.73	53.03	100	288	Average
8	4924.00	54.40	68.06	74.00	-19.60	31.64	7.73	53.03	100	288	Peak
9 !	7386.00	53.54	58.99	54.00	-0.46	36.43	9.72	51.60	132	274	Average
10	7386.00	65.65	71.10	74.00	-8.35	36.43	9.72	51.60	132	274	Peak

NOTE: Item 3, 4 were fundamental frequency.



A D T



Bureau Veritas Consumer Products Services Ltd., Taoyuan Branch

A D T

Data: 15

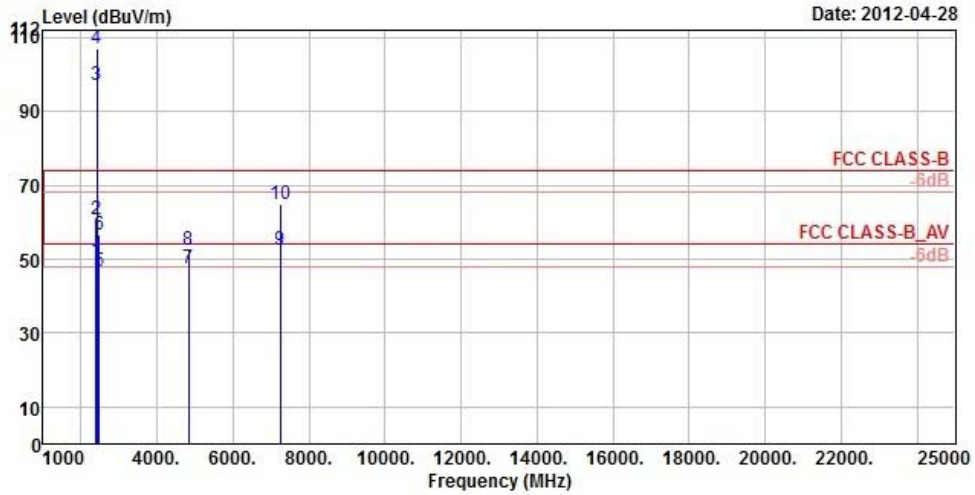

Site : 966 Chamber 5
 Condition : FCC CLASS-B 3m ANT_1G~18G_HF HORIZONTAL
 Brand/Model: F-11D
 Remark : 11N Tx CH01
 Tested by : Kay Wu
 Temperature : 25°C
 Humidity : 65%
 Plane : Y
 Power : 13
 Date : MCS0

	Freq	Level	Read Level	Limit Line	OverLimit	Antenna Factor	Cable Loss	Preamp Factor	A/Pos	T/Pos	Remark
	MHz	dBuV/m	dBuV	dBuV/m	dB	dB/m	dB	dB	cm	deg	
1 !	2390.00	49.68	55.07	54.00	-4.32	27.26	4.87	37.52	129	48	Average
2	2390.00	60.68	66.07	74.00	-13.32	27.26	4.87	37.52	129	48	Peak
3 pp	2412.00	97.29	102.63	54.00	43.29	27.31	4.87	37.52	129	48	Average
4 pk	2412.00	107.17	112.51	74.00	33.17	27.31	4.87	37.52	129	48	Peak
5	2483.50	46.71	51.61	54.00	-7.29	27.50	4.92	37.32	129	48	Average
6	2483.50	56.41	61.31	74.00	-17.59	27.50	4.92	37.32	129	48	Peak
7	4824.00	47.63	61.59	54.00	-6.37	31.42	7.70	53.08	100	99	Average
8	4824.00	52.53	66.49	74.00	-21.47	31.42	7.70	53.08	100	99	Peak
9 !	7236.00	52.29	58.68	77.29	-25.00	36.05	9.57	52.01	100	58	Average
10	7236.00	64.99	71.38	87.17	-22.18	36.05	9.57	52.01	100	58	Peak

NOTE: Item 3, 4 were fundamental frequency.



A D T



Bureau Veritas Consumer Products Services Ltd., Taoyuan Branch

A D T

Data: 16

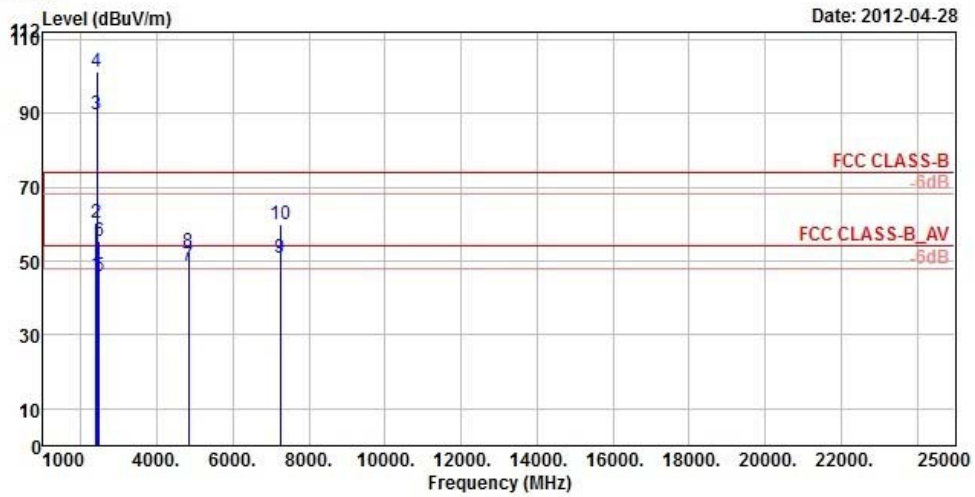

Site : 966 Chamber 5
 Condition : FCC CLASS-B 3m ANT_1G~18G_HF VERTICAL
 Brand/Model: F-11D
 Remark : 11N Tx CH01
 Tested by : Kay Wu
 Temperature : 25°C
 Humidity : 65%
 Plane : Y
 Power : 13
 Date : MCS0

	Freq	Level	Read Level	Limit Line	OverLimit	Antenna Factor	Cable Loss	Preamp Factor	A/Pos	T/Pos	Remark
	MHz	dBuV/m	dBuV	dBuV/m	dB	dB/m	dB	dB	cm	deg	
1	2390.00	46.23	51.62	54.00	-7.77	27.26	4.87	37.52	100	347	Average
2	2390.00	60.18	65.57	74.00	-13.82	27.26	4.87	37.52	100	347	Peak
3	2412.00	89.89	95.23	54.00	35.89	27.31	4.87	37.52	100	347	Average
4	2412.00	101.42	106.76	74.00	27.42	27.31	4.87	37.52	100	347	Peak
5	2483.50	46.07	50.97	54.00	-7.93	27.50	4.92	37.32	100	347	Average
6	2483.50	55.54	60.44	74.00	-18.46	27.50	4.92	37.32	100	347	Peak
7	4824.00	48.61	62.57	54.00	-5.39	31.42	7.70	53.08	100	97	Average
8	4824.00	52.38	66.34	74.00	-21.62	31.42	7.70	53.08	100	97	Peak
9	7236.00	50.69	57.20	69.89	-19.20	36.01	9.57	52.09	100	88	Average
10	7236.00	59.75	66.26	81.42	-21.67	36.01	9.57	52.09	100	88	Peak

NOTE: Item 3, 4 were fundamental frequency.



A D T



Bureau Veritas Consumer Products Services Ltd., Taoyuan Branch

A D T

Data: 15

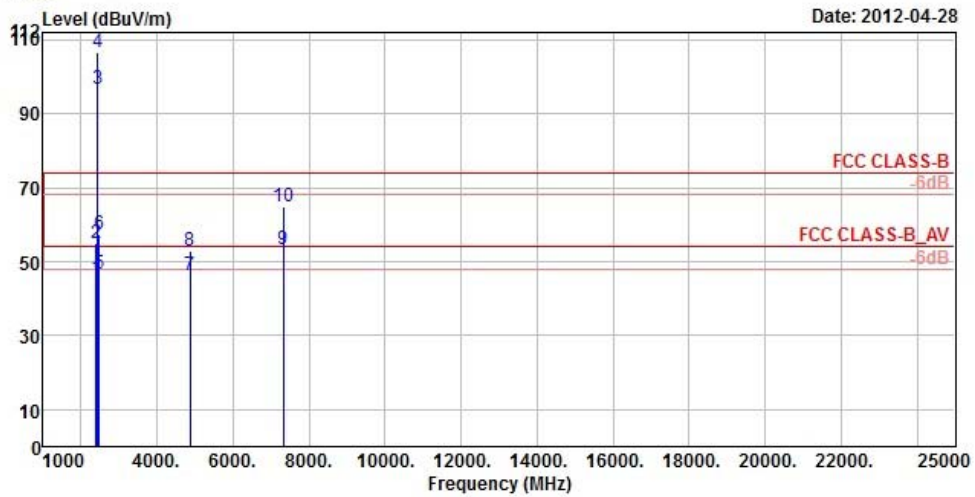

Site : 966 Chamber 5
 Condition : FCC CLASS-B 3m ANT_1G~18G_HF HORIZONTAL
 Brand/Model: F-11D
 Remark : 11N Tx CH06
 Tested by : Kay Wu
 Temperature : 25°C
 Humidity : 65%
 Plane : Y
 Power : 13
 Date : MCS0

	Freq	Level	Read Level	Limit Line	OverLimit	Antenna Factor	Cable Loss	Preamp Factor	A/Pos	T/Pos	Remark
	MHz	dBuV/m	dBuV	dBuV/m	dB	dB/m	dB	dB	cm	deg	
1	2390.00	45.42	50.81	54.00	-8.58	27.26	4.87	37.52	127	49	Average
2	2390.00	55.06	60.45	74.00	-18.94	27.26	4.87	37.52	127	49	Peak
3 pp	2437.00	96.79	101.96	54.00	42.79	27.40	4.89	37.46	127	49	Average
4 pk	2437.00	106.47	111.64	74.00	32.47	27.40	4.89	37.46	127	49	Peak
5	2483.50	46.68	51.58	54.00	-7.32	27.50	4.92	37.32	127	49	Average
6	2483.50	57.34	62.24	74.00	-16.66	27.50	4.92	37.32	127	49	Peak
7	4874.00	46.34	60.14	54.00	-7.66	31.53	7.72	53.05	100	199	Average
8	4874.00	52.85	66.65	74.00	-21.15	31.53	7.72	53.05	100	199	Peak
9 !	7311.00	53.19	59.24	54.00	-0.81	36.22	9.58	51.85	100	285	Average
10	7311.00	65.03	71.08	74.00	-8.97	36.22	9.58	51.85	100	285	Peak

NOTE: Item 3, 4 were fundamental frequency.



A D T



Bureau Veritas Consumer Products Services Ltd., Taoyuan Branch

A D T

Data: 16

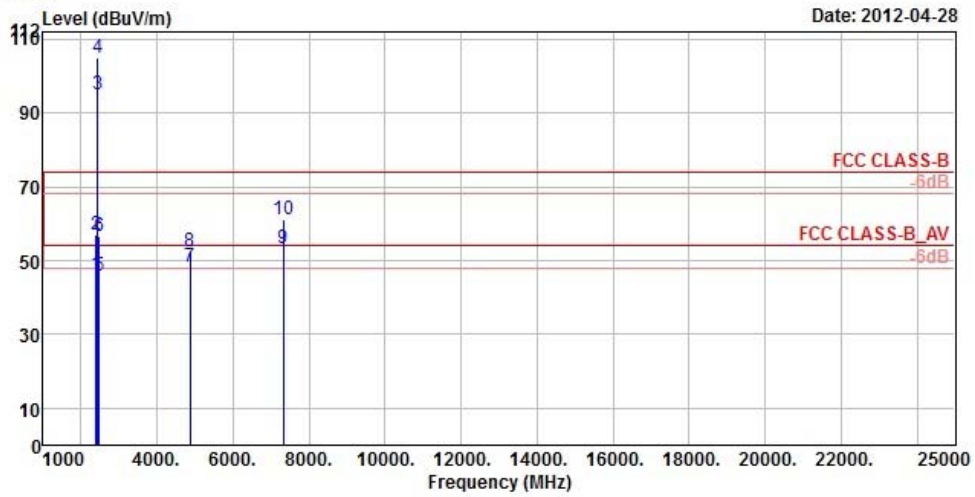

Site : 966 Chamber 5
 Condition : FCC CLASS-B 3m ANT_1G~18G_HF VERTICAL
 Brand/Model: F-11D
 Remark : 11N Tx CH06
 Tested by : Kay Wu
 Temperature : 25°C
 Humidity : 65%
 Plane : Y
 Power : 13
 Date : MCS0

	Freq	Level	Read Level	Limit Line	OverLimit	Antenna Factor	Cable Loss	Preamp Factor	A/Pos	T/Pos	Remark
	MHz	dBuV/m	dBuV	dBuV/m	dB	dB/m	dB	dB	cm	deg	
1	2390.00	46.45	51.84	54.00	-7.55	27.26	4.87	37.52	116	147	Average
2	2390.00	56.94	62.33	74.00	-17.06	27.26	4.87	37.52	116	147	Peak
3 pp	2437.00	95.13	100.30	54.00	41.13	27.40	4.89	37.46	116	147	Average
4 pk	2437.00	104.79	109.96	74.00	30.79	27.40	4.89	37.46	116	147	Peak
5	2483.50	45.96	50.86	54.00	-8.04	27.50	4.92	37.32	116	147	Average
6	2483.50	56.82	61.72	74.00	-17.18	27.50	4.92	37.32	116	147	Peak
7 !	4874.00	48.40	62.20	54.00	-5.60	31.53	7.72	53.05	100	27	Average
8	4874.00	52.61	66.41	74.00	-21.39	31.53	7.72	53.05	100	27	Peak
9 !	7311.00	53.27	59.32	54.00	-0.73	36.22	9.58	51.85	100	99	Average
10	7311.00	61.13	67.18	74.00	-12.87	36.22	9.58	51.85	100	99	Peak

NOTE: Item 3, 4 were fundamental frequency.



A D T



Bureau Veritas Consumer Products Services Ltd., Taoyuan Branch

A D T

Data: 17

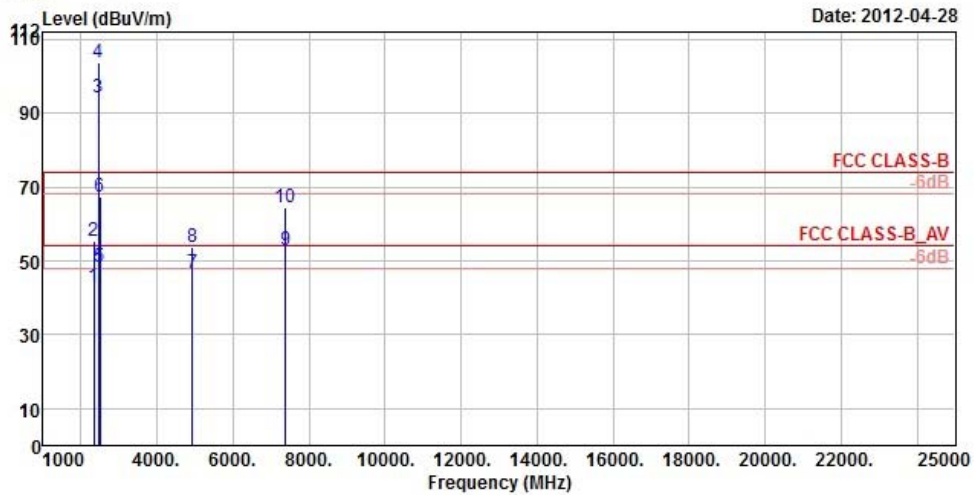

Site : 966 Chamber 5
 Condition : FCC CLASS-B 3m ANT_1G~18G_HF HORIZONTAL
 Brand/Model: F-11D
 Remark : 11N Tx CH11
 Tested by : Kay Wu
 Temperature : 25°C
 Humidity : 65%
 Plane : Y
 Power : 13
 Date : MCS0

	Freq	Level	Read Level	Limit Line	OverLimit	Antenna Factor	Cable Loss	Preamp Factor	A/Pos	T/Pos	Remark
	MHz	dBuV/m	dBuV	dBuV/m	dB	dB/m	dB	dB	cm	deg	
1	2326.00	42.87	49.10	54.00	-11.13	27.06	4.18	37.47	100	45	Average
2	2326.00	55.34	61.57	74.00	-18.66	27.06	4.18	37.47	100	45	Peak
3 pp	2462.00	94.16	99.83	54.00	40.16	27.45	4.27	37.39	100	45	Average
4 pk	2462.00	103.59	109.26	74.00	29.59	27.45	4.27	37.39	100	45	Peak
5 !	2485.37	48.31	53.85	54.00	-5.69	27.50	4.28	37.32	100	45	Average
6	2485.37	67.39	72.93	74.00	-6.61	27.50	4.28	37.32	100	45	Peak
7	4924.00	46.56	60.22	54.00	-7.44	31.64	7.73	53.03	100	89	Average
8	4924.00	53.66	67.32	74.00	-20.34	31.64	7.73	53.03	100	89	Peak
9 !	7386.00	52.90	58.35	54.00	-1.10	36.43	9.72	51.60	100	138	Average
10	7386.00	64.32	69.77	74.00	-9.68	36.43	9.72	51.60	100	138	Peak

NOTE: Item 3, 4 were fundamental frequency.



A D T



Bureau Veritas Consumer Products Services Ltd., Taoyuan Branch

A D T

Data: 18

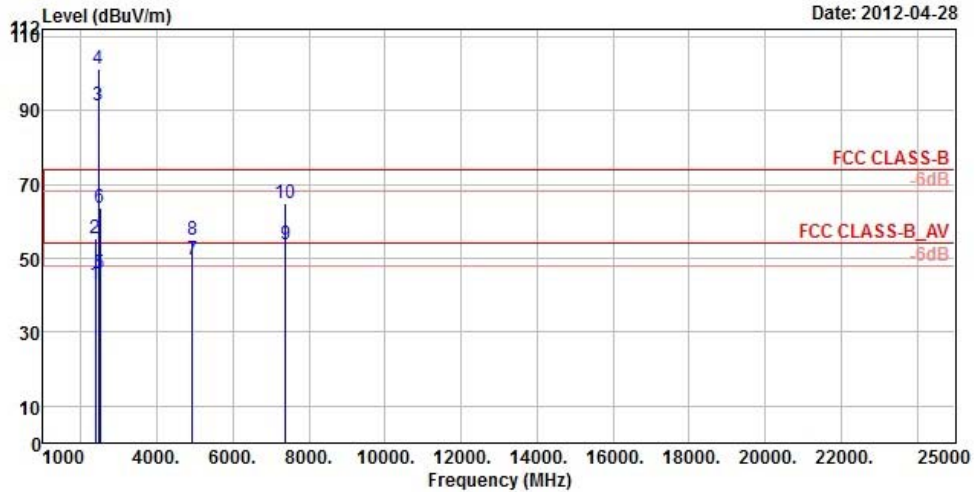

Site : 966 Chamber 5
 Condition : FCC CLASS-B 3m ANT_1G~18G_HF VERTICAL
 Brand/Model: F-11D
 Remark : 11N Tx CH11
 Tested by : Kay Wu
 Temperature : 25°C
 Humidity : 65%
 Plane : Y
 Power : 13
 Date : MCS0

	Freq	Level	Read Level	Limit Line	OverLimit	Antenna Factor	Cable Loss	Preamp Factor	A/Pos	T/Pos	Remark
	MHz	dBuV/m	dBuV	dBuV/m	dB	dB/m	dB	dB	cm	deg	
1	2364.00	43.11	49.24	54.00	-10.89	27.16	4.20	37.49	104	248	Average
2	2364.00	55.54	61.67	74.00	-18.46	27.16	4.20	37.49	104	248	Peak
3 pp	2462.00	91.15	96.82	54.00	37.15	27.45	4.27	37.39	104	248	Average
4 pk	2462.00	101.40	107.07	74.00	27.40	27.45	4.27	37.39	104	248	Peak
5	2484.80	45.97	51.51	54.00	-8.03	27.50	4.28	37.32	104	248	Average
6	2484.80	63.59	69.13	74.00	-10.41	27.50	4.28	37.32	104	248	Peak
7 !	4924.00	49.57	63.23	54.00	-4.43	31.64	7.73	53.03	100	87	Average
8	4924.00	55.03	68.69	74.00	-18.97	31.64	7.73	53.03	100	87	Peak
9 !	7386.00	53.78	59.23	54.00	-0.22	36.43	9.72	51.60	185	55	Average
10	7386.00	64.86	70.31	74.00	-9.14	36.43	9.72	51.60	185	55	Peak

NOTE: Item 3, 4 were fundamental frequency.



A D T

BELOW 1GHz WORST-CASE DATA :



Bureau Veritas Consumer Products Services Ltd., Taoyuan Branch

A D T

Data: 5

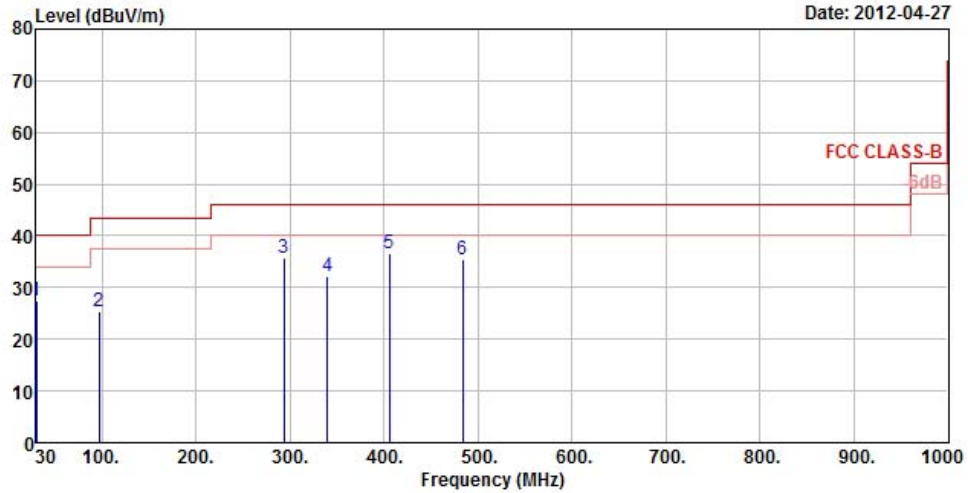

Site : 966 Chamber 5
 Condition : FCC CLASS-B 3m ANT_30M~1G_LF HORIZONTAL
 Brand/Model: F-11D
 Remark : WIFI LF
 Tested by : Kay Wu
 Temperature : 25°C
 Humidity : 65%
 Plane : Y

	Freq	Level	Read Level	Limit Line	OverAntenna Limit	Antenna Factor	Cable Loss	Preamp Factor	A/Pos	T/Pos	Remark
	MHz	dBuV/m	dBuV	dBuV/m	dB	dB/m	dB	dB	cm	deg	
1	30.27	27.41	46.00	40.00	-12.59	11.98	0.57	31.14	125	187	Peak
2	96.69	25.29	47.37	43.50	-18.21	8.83	1.05	31.96	110	285	Peak
3	293.52	35.69	52.64	46.00	-10.31	12.77	2.02	31.74	133	214	Peak
4	339.90	32.32	48.06	46.00	-13.68	13.89	2.19	31.82	100	88	Peak
5 pp	405.70	36.47	50.62	46.00	-9.53	15.45	2.45	32.05	207	333	Peak
6	483.40	35.53	47.66	46.00	-10.47	16.98	2.72	31.83	107	44	Peak



A D T



Bureau Veritas Consumer Products Services Ltd., Taoyuan Branch

A D T

Data: 6

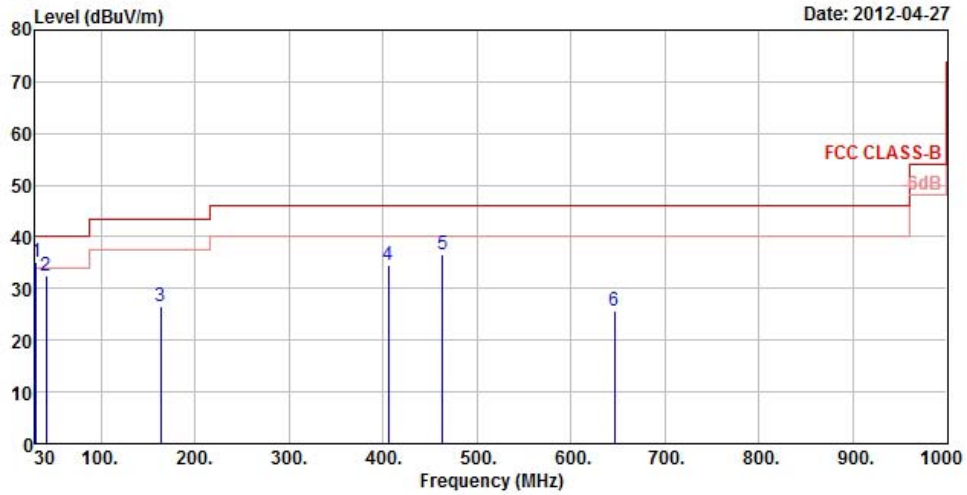

Site : 966 Chamber 5
 Condition : FCC CLASS-B 3m ANT_30M~1G_LF VERTICAL
 Brand/Model: F-11D
 Remark : WIFI LF
 Tested by : Kay Wu
 Temperature : 25°C
 Humidity : 65%
 Plane : Y

	Freq	Level	Read Level	Limit Line	OverLimit	Antenna Factor	Cable Loss	Preamp Factor	A/Pos	T/Pos	Remark
	MHz	dBuV/m	dBuV	dBuV/m	dB	dB/m	dB	dB	cm	deg	
1	pp	31.08	35.21	53.62	40.00	-4.79	12.14	0.57	31.12	105	251 QP
2	pk	41.34	32.37	49.18	40.00	-7.63	13.56	0.68	31.05	101	271 Peak
3		163.92	26.48	44.55	43.50	-17.02	12.34	1.41	31.82	195	254 Peak
4		405.70	34.60	48.75	46.00	-11.40	15.45	2.45	32.05	133	285 Peak
5		463.80	36.72	49.41	46.00	-9.28	16.60	2.66	31.95	274	114 Peak
6		646.50	25.57	34.21	46.00	-20.43	20.17	3.23	32.04	100	331 Peak



4.2 CONDUCTED EMISSION MEASUREMENT

4.2.1 LIMITS OF CONDUCTED EMISSION MEASUREMENT

FREQUENCY OF EMISSION (MHz)	CONDUCTED LIMIT (dBµV)	
	Quasi-peak	Average
0.15 ~ 0.5	66 to 56	56 to 46
0.5 ~ 5	56	46
5 ~ 30	60	50

- NOTE:**
1. The lower limit shall apply at the transition frequencies.
 2. The limit decreases in line with the logarithm of the frequency in the range of 0.15 to 0.50MHz.
 3. All emanations from a class A/B digital device or system, including any network of conductors and apparatus connected thereto, shall not exceed the level of field strengths specified above.

4.2.2 TEST INSTRUMENTS

DESCRIPTION & MANUFACTURER	MODEL NO.	SERIAL NO.	DATE OF CALIBRATION	DUE DATE OF CALIBRATION
Test Receiver ROHDE & SCHWARZ	ESCS30	100289	Nov. 19, 2011	Nov. 18, 2012
RF signal cable Woken	5D-FB	Cable-HYCO2-01	Dec. 22, 2011	Dec. 21, 2012
LISN ROHDE & SCHWARZ	ESH2-Z5	100100	Dec. 30, 2011	Dec. 29, 2012
LISN ROHDE & SCHWARZ	ESH3-Z5	100312	Jul. 07, 2011	Jul. 06, 2012
Software ADT	ADT_Cond_ V7.3.7	NA	NA	NA

- NOTE:**
1. The calibration interval of the above test instruments is 12 months and the calibrations are traceable to NML/ROC and NIST/USA.
 2. The test was performed in HwaYa Shielded Room 2.
 3. The VCCI Site Registration No. is C-2047.

4.2.3 TEST PROCEDURES

- a. The EUT was placed 0.4 meters from the conducting wall of the shielded room with EUT being connected to the power mains through a line impedance stabilization network (LISN). Other support units were connected to the power mains through another LISN. The two LISNs provide 50 ohm/ 50uH of coupling impedance for the measuring instrument.
- b. Both lines of the power mains connected to the EUT were checked for maximum conducted interference.
- c. The frequency range from 150kHz to 30MHz was searched. Emission levels under (Limit - 20dB) was not recorded.

NOTE: All modes of operation were investigated and the worst-case emissions are reported.

4.2.4 DEVIATION FROM TEST STANDARD

No deviation.

4.2.5 TEST SETUP

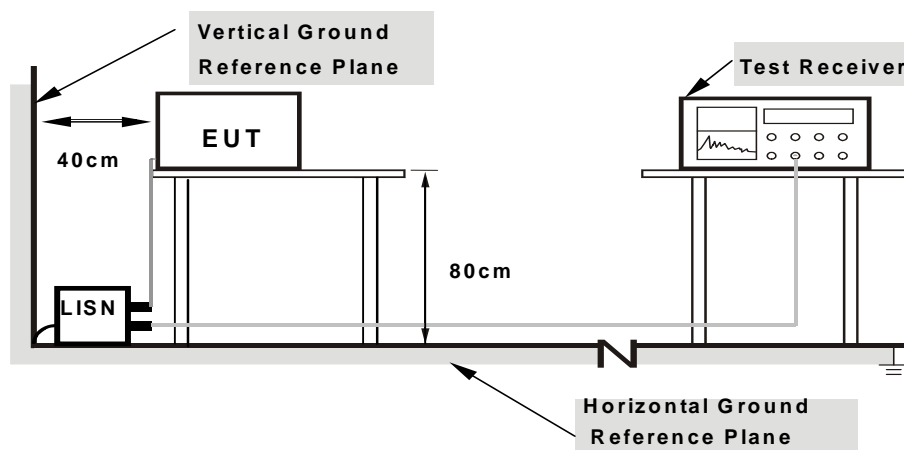

- Note:**
1. Support units were connected to second LISN.
 2. Both of LISNs (AMN) are 80 cm from EUT and at least 80 cm from other units and other metal planes

For the actual test configuration, please refer to the attached file (Test Setup Photo).

4.2.6 EUT OPERATING CONDITIONS

Same as 4.1.6.

4.2.7 TEST RESULTS

CONDUCTED WORST-CASE DATA : 802.11n(20MHz)

PHASE	Line 1	6dB BANDWIDTH	9kHz
--------------	--------	----------------------	------

No	Freq. [MHz]	Corr. Factor (dB)	Reading Value		Emission Level		Limit		Margin	
			[dB (uV)]		[dB (uV)]		[dB (uV)]		(dB)	
			Q.P.	AV.	Q.P.	AV.	Q.P.	AV.	Q.P.	AV.
1	0.16172	0.15	56.30	41.86	56.45	42.01	65.38	55.38	-8.93	-13.37
2	0.21641	0.15	51.41	37.40	51.56	37.55	62.96	52.96	-11.39	-15.40
3	0.85703	0.19	31.50	22.08	31.69	22.27	56.00	46.00	-24.31	-23.73
4	1.89063	0.25	31.03	22.32	31.28	22.57	56.00	46.00	-24.72	-23.43
5	7.22266	0.39	24.46	18.50	24.85	18.89	60.00	50.00	-35.15	-31.11
6	27.67969	0.54	36.81	25.99	37.35	26.53	60.00	50.00	-22.65	-23.47

- REMARKS:**
1. Q.P. and AV. are abbreviations of quasi-peak and average individually.
 2. "-": The Quasi-peak reading value also meets average limit and measurement with the average detector is unnecessary.
 3. The emission levels of other frequencies were very low against the limit.
 4. Margin value = Emission level - Limit value
 5. Correction factor = Insertion loss + Cable loss
 6. Emission Level = Correction Factor + Reading Value.

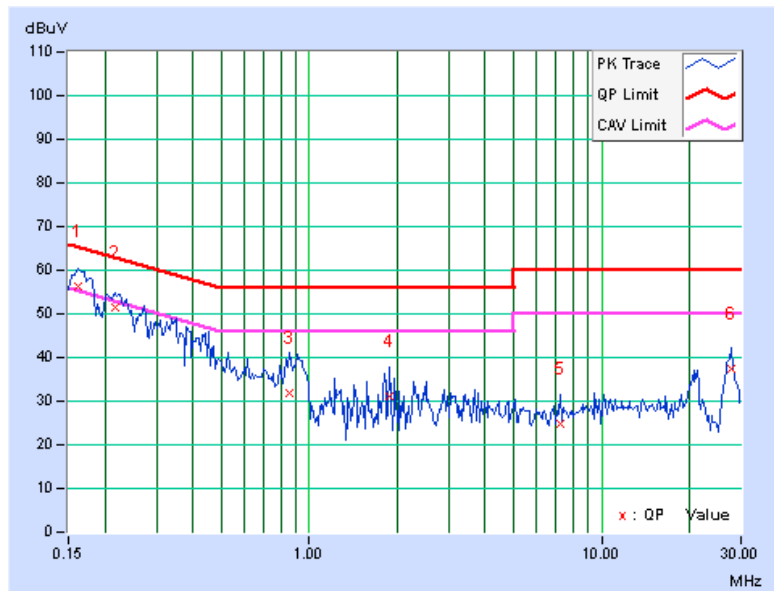

PHASE	Line 2	6dB BANDWIDTH	9kHz
-------	--------	---------------	------

No	Freq. [MHz]	Corr. Factor (dB)	Reading Value		Emission Level		Limit		Margin	
			[dB (uV)]		[dB (uV)]		[dB (uV)]		(dB)	
			Q.P.	AV.	Q.P.	AV.	Q.P.	AV.	Q.P.	AV.
1	0.15391	0.13	54.36	37.89	54.49	38.02	65.79	55.79	-11.30	-17.77
2	0.21641	0.14	50.99	36.70	51.13	36.84	62.96	52.96	-11.82	-16.11
3	0.95078	0.19	32.19	23.41	32.38	23.60	56.00	46.00	-23.62	-22.40
4	1.43359	0.22	32.27	23.35	32.49	23.57	56.00	46.00	-23.51	-22.43
5	20.73438	0.71	32.86	20.62	33.57	21.33	60.00	50.00	-26.43	-28.67
6	27.57813	0.58	36.83	25.95	37.41	26.53	60.00	50.00	-22.59	-23.47

- REMARKS:**
1. Q.P. and AV. are abbreviations of quasi-peak and average individually.
 2. "-": The Quasi-peak reading value also meets average limit and measurement with the average detector is unnecessary.
 3. The emission levels of other frequencies were very low against the limit.
 4. Margin value = Emission level - Limit value
 5. Correction factor = Insertion loss + Cable loss
 6. Emission Level = Correction Factor + Reading Value.

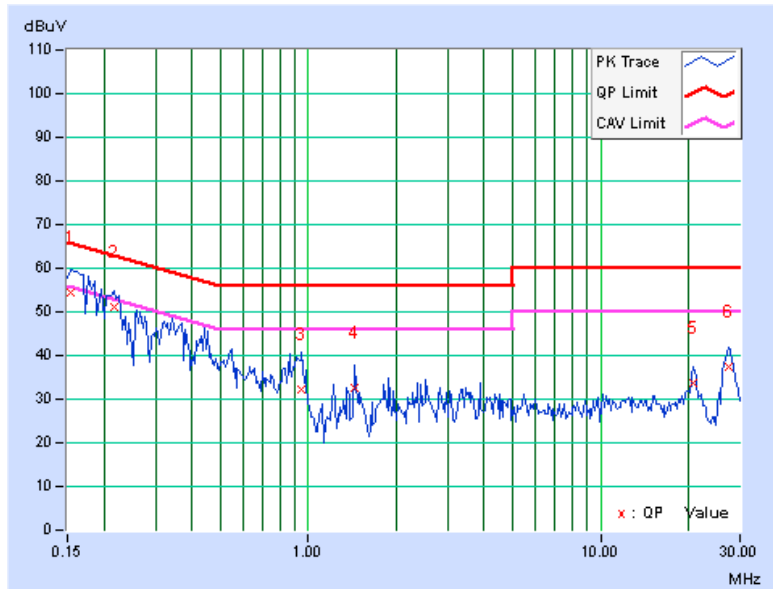

4.3 6dB BANDWIDTH MEASUREMENT

4.3.1 LIMITS OF 6dB BANDWIDTH MEASUREMENT

The minimum of 6dB Bandwidth Measurement is 0.5 MHz.

4.3.2 TEST SETUP

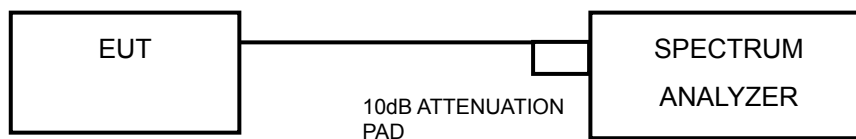

4.3.3 TEST INSTRUMENTS

Refer to section 4.1.2 to get information of above instrument.

4.3.4 TEST PROCEDURE

- a. Set resolution bandwidth (RBW) = approximately 1% of the emission bandwidth
- b. Set the video bandwidth (VBW) $\geq 3 \times$ RBW, Detector = Peak.
- c. Trace mode = max hold.
- d. Sweep = auto couple.
- e. Measure the maximum width of the emission that is constrained by the frequencies associated with the two amplitude points (upper and lower) that are attenuated by 6 dB relative to the maximum level measured in the fundamental emission

4.3.5 DEVIATION FROM TEST STANDARD

No deviation.

4.3.6 EUT OPERATING CONDITIONS

The software provided by client to enable the EUT under transmission condition continuously at lowest, middle and highest channel frequencies individually.



4.3.7 TEST RESULTS

802.11b

CHANNEL	FREQUENCY (MHz)	6dB BANDWIDTH (MHz)	MINIMUM LIMIT (MHz)	PASS / FAIL
1	2412	7.60	0.5	PASS
6	2437	7.42	0.5	PASS
11	2462	7.36	0.5	PASS

802.11g

CHANNEL	FREQUENCY (MHz)	6dB BANDWIDTH (MHz)	MINIMUM LIMIT (MHz)	PASS / FAIL
1	2412	15.10	0.5	PASS
6	2437	15.10	0.5	PASS
11	2462	15.12	0.5	PASS

802.11n (20MHz)

CHANNEL	FREQUENCY (MHz)	6dB BANDWIDTH (MHz)	MINIMUM LIMIT (MHz)	PASS / FAIL
1	2412	16.08	0.5	PASS
6	2437	16.07	0.5	PASS
11	2462	16.06	0.5	PASS

4.4 CONDUCTED OUTPUT POWER

4.4.1 LIMITS OF CONDUCTED OUTPUT POWER MEASUREMENT

For systems using digital modulation in the 2400–2483.5 MHz bands: 1 Watt (30dBm)

4.4.2 TEST SETUP

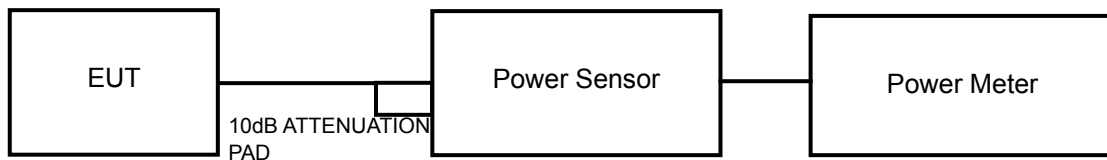

4.4.3 TEST INSTRUMENTS

Refer to section 4.1.2 to get information of above instrument.

4.4.4 TEST PROCEDURES

A peak power sensor was used on the output port of the EUT. A power meter was used to read the response of the peak power sensor. Record the peak power level.

4.4.5 DEVIATION FROM TEST STANDARD

No deviation.

4.4.6 EUT OPERATING CONDITIONS

Same as Item 4.3.6.



A D T

4.4.7 TEST RESULTS

802.11b

CHANNEL	FREQUENCY (MHz)	PEAK POWER (W)	PEAK POWER (dBm)	LIMIT (dBm)	PASS/FAIL
1	2412	0.060	17.75	30	PASS
6	2437	0.038	15.85	30	PASS
11	2462	0.041	16.18	30	PASS

802.11g

CHANNEL	FREQUENCY (MHz)	PEAK POWER (W)	PEAK POWER (dBm)	LIMIT (dBm)	PASS/FAIL
1	2412	0.186	22.70	30	PASS
6	2437	0.148	21.71	30	PASS
11	2462	0.151	21.79	30	PASS

802.11n (20MHz)

CHANNEL	FREQUENCY (MHz)	PEAK POWER (W)	PEAK POWER (dBm)	LIMIT (dBm)	PASS/FAIL
1	2412	0.159	22.02	30	PASS
6	2437	0.164	22.15	30	PASS
11	2462	0.163	22.11	30	PASS

4.5 POWER SPECTRAL DENSITY MEASUREMENT

4.5.1 LIMITS OF POWER SPECTRAL DENSITY MEASUREMENT

The Maximum of Power Spectral Density Measurement is 8dBm.

4.5.2 TEST SETUP

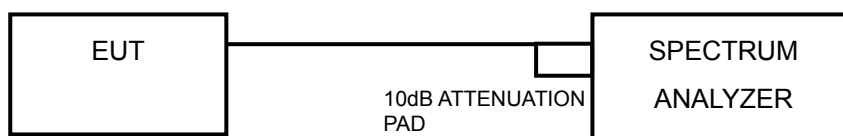

4.5.3 TEST INSTRUMENTS

Refer to section 4.1.2 to get information of above instrument.

4.5.4 TEST PROCEDURE

- Set the RBW = 100 kHz, VBW = 300 kHz, Detector = peak.
- Sweep time = auto couple, Trace mode = max hold, allow trace to fully stabilize.
- Use the peak marker function to determine the maximum power level in any 100 kHz band segment within the fundamental EBW.
- Scale the observed power level to an equivalent value in 3 kHz by adjusting (reducing) the measured power by a bandwidth correction factor (BWCF) where $BWCF = 10\log(3 \text{ kHz}/100\text{kHz})$

4.5.5 DEVIATION FROM TEST STANDARD

No deviation.

4.5.6 EUT OPERATING CONDITION

Same as Item 4.3.6



A D T

4.5.7 TEST RESULTS

802.11b

Channel	FREQ. (MHz)	PSD (dBm/100kHz)	PSD (dBm/3kHz)	Limit (dBm/3kHz)	PASS /FAIL
1	2412	8.87	-6.36	8	PASS
6	2437	6.86	-8.37	8	PASS
11	2462	6.96	-8.27	8	PASS

CH 1

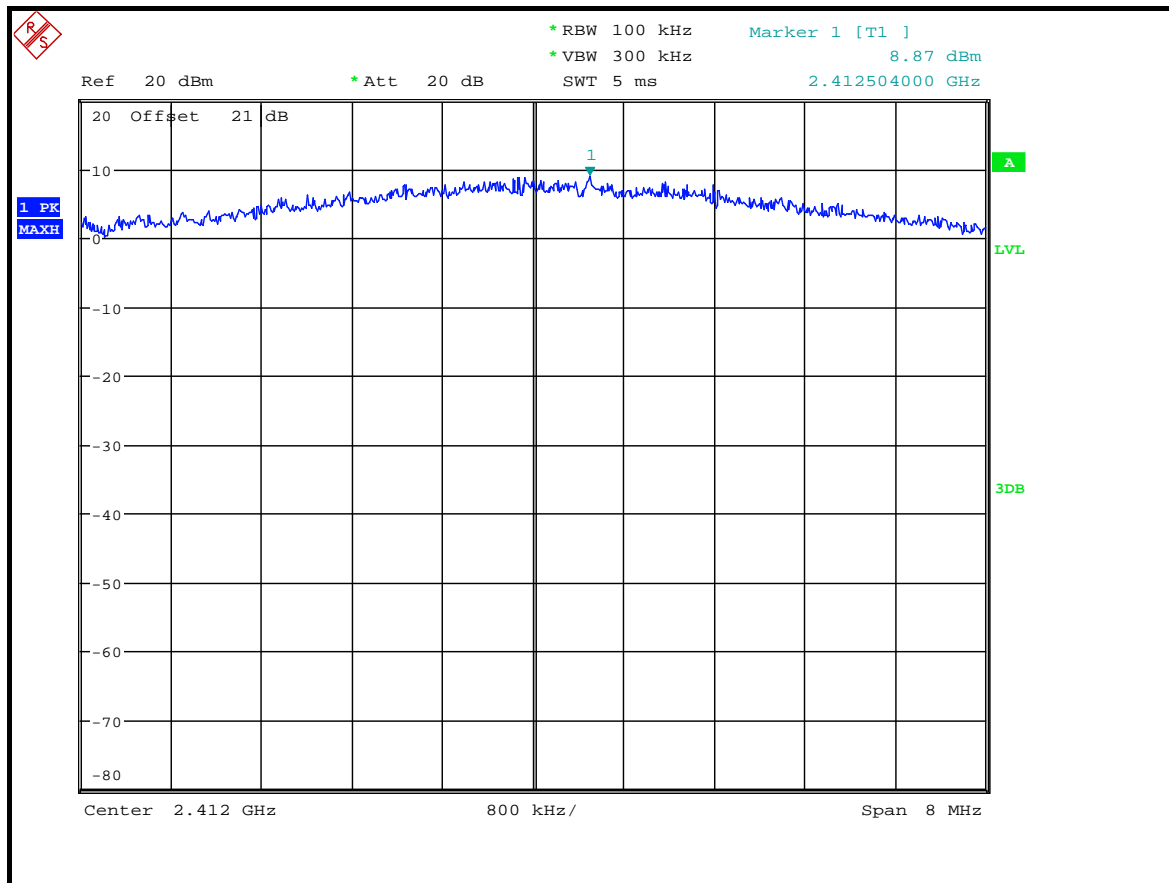



A D T

802.11g

Channel	FREQ. (MHz)	PSD (dBm/100kHz)	PSD (dBm/3kHz)	Limit (dBm/3kHz)	PASS /FAIL
1	2412	5.07	-10.16	8	PASS
6	2437	2.13	-13.10	8	PASS
11	2462	2.27	-12.96	8	PASS

CH 1

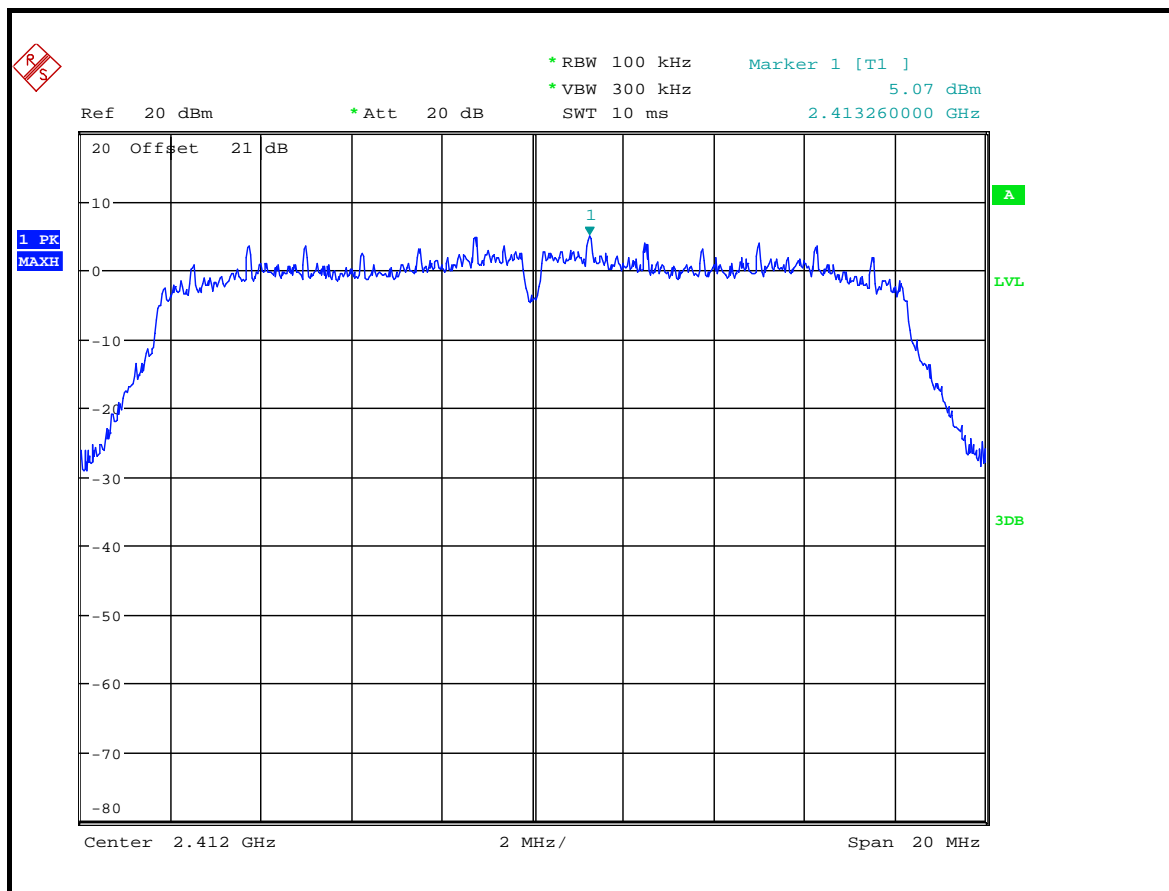



A D T

802.11n (20MHz)

Channel	FREQ. (MHz)	PSD (dBm/100kHz)	PSD (dBm/3kHz)	Limit (dBm/3kHz)	PASS /FAIL
1	2412	3.14	-12.09	8	PASS
6	2437	3.32	-11.91	8	PASS
11	2462	3.43	-11.80	8	PASS

CH 11

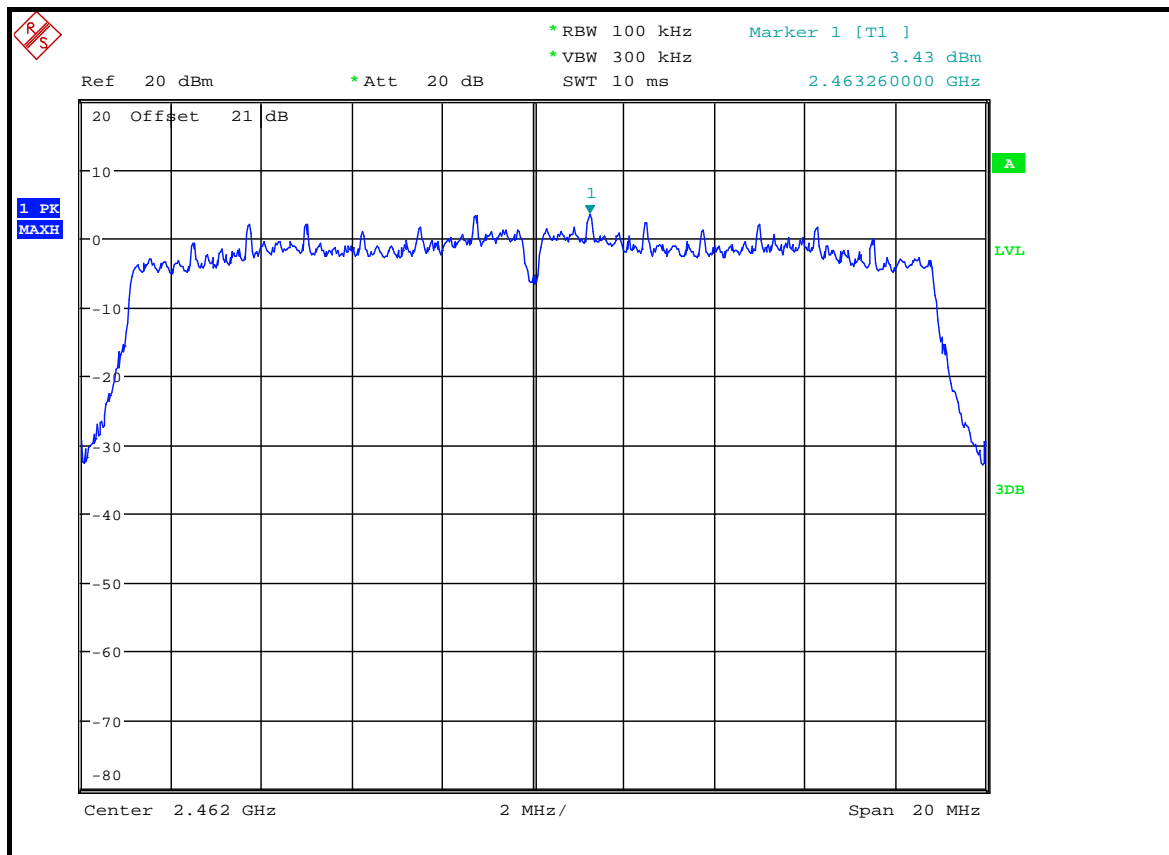

4.6 CONDUCTED OUT OF BAND EMISSION MEASUREMENT

4.6.1 LIMITS OF CONDUCTED OUT OF BAND EMISSION MEASUREMENT

Below -20dB of the highest emission level of operating band (in 100kHz Resolution Bandwidth).

4.6.2 TEST SETUP

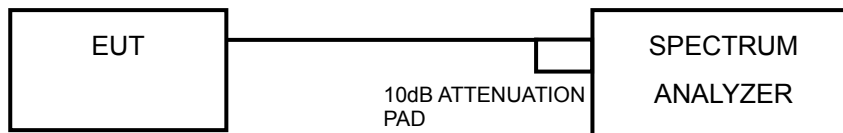

4.6.3 TEST INSTRUMENTS

Refer to section 4.1.2 to get information of above instrument.

4.6.4 TEST PROCEDURE

MEASUREMENT PROCEDURE REF

1. Set the RBW = 100 kHz.
2. Set the VBW \geq 300 kHz.
3. Detector = peak.
4. Sweep time = auto couple.
5. Trace mode = max hold.
6. Allow trace to fully stabilize.
7. Use the peak marker function to determine the maximum power level in any 100 kHz band segment within the fundamental EBW.



A D T

MEASUREMENT PROCEDURE OOB

1. Set RBW = 100 kHz.
2. Set VBW \geq 300 kHz.
3. Set span to encompass the spectrum to be examined.
4. Detector = peak.
5. Trace Mode = max hold.
6. Sweep = auto couple.

4.6.5 DEVIATION FROM TEST STANDARD

No deviation.

4.6.6 EUT OPERATING CONDITION

Same as Item 4.3.6

4.6.7 TEST RESULTS

The spectrum plots are attached on the following pages. D1 line indicates the highest level, and D2 line indicates the 20dB offset below D1. It shows compliance with the requirement.

4.6.8 TEST RESULTS

Conducted Band Edges

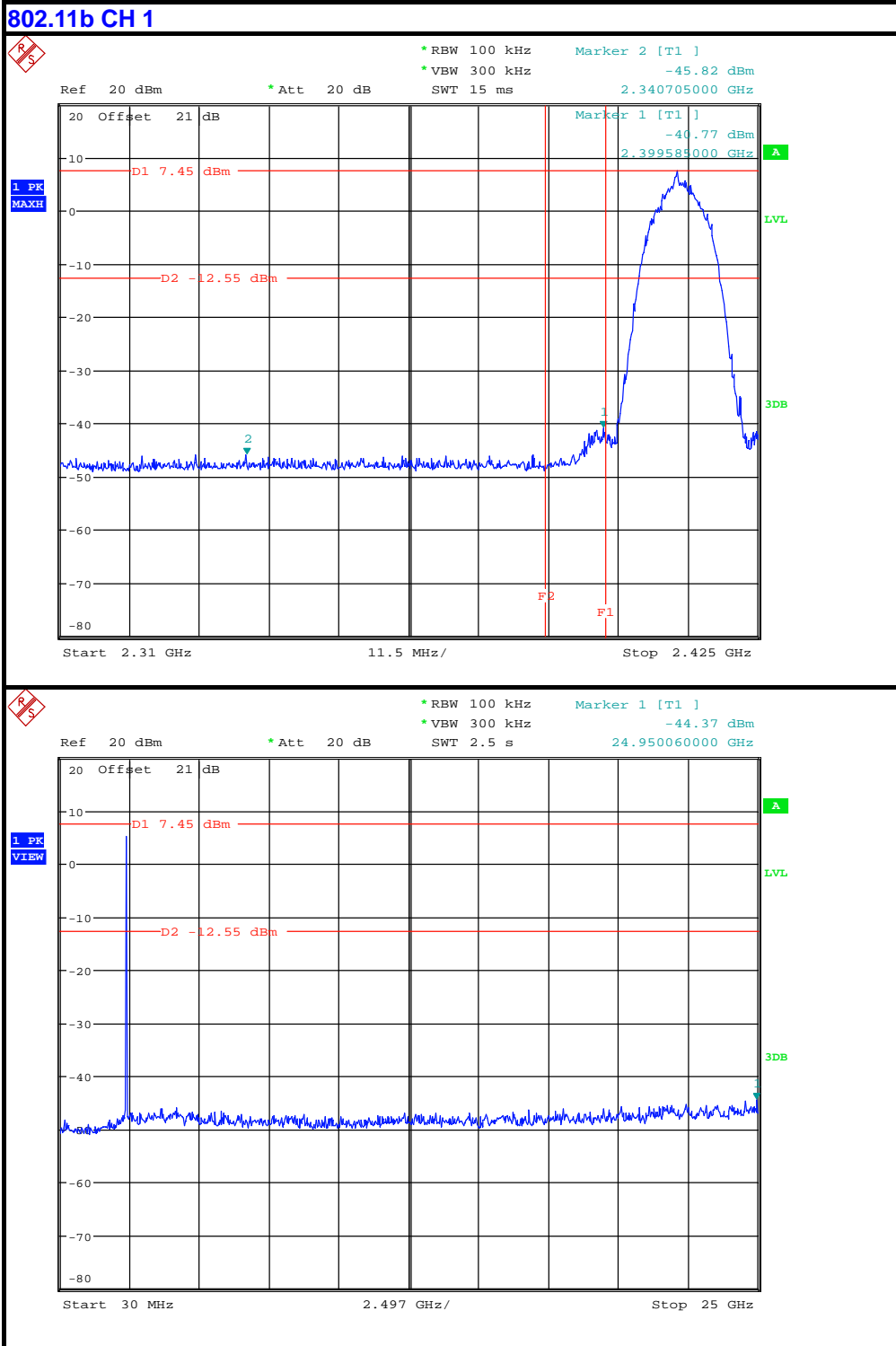



A D T

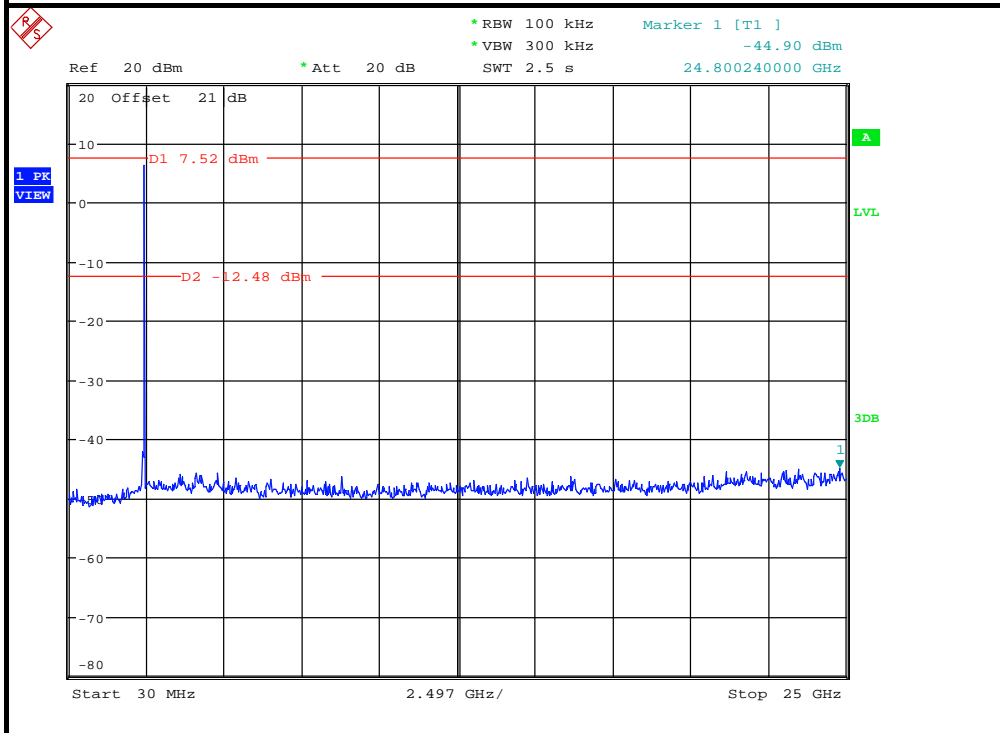
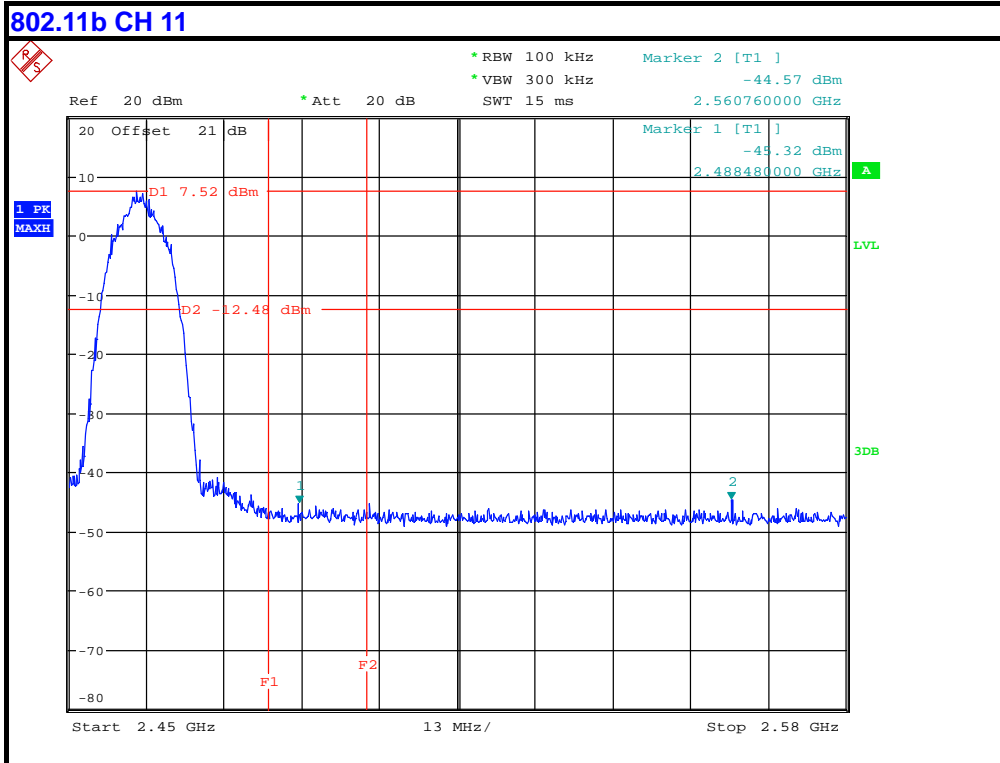



A D T

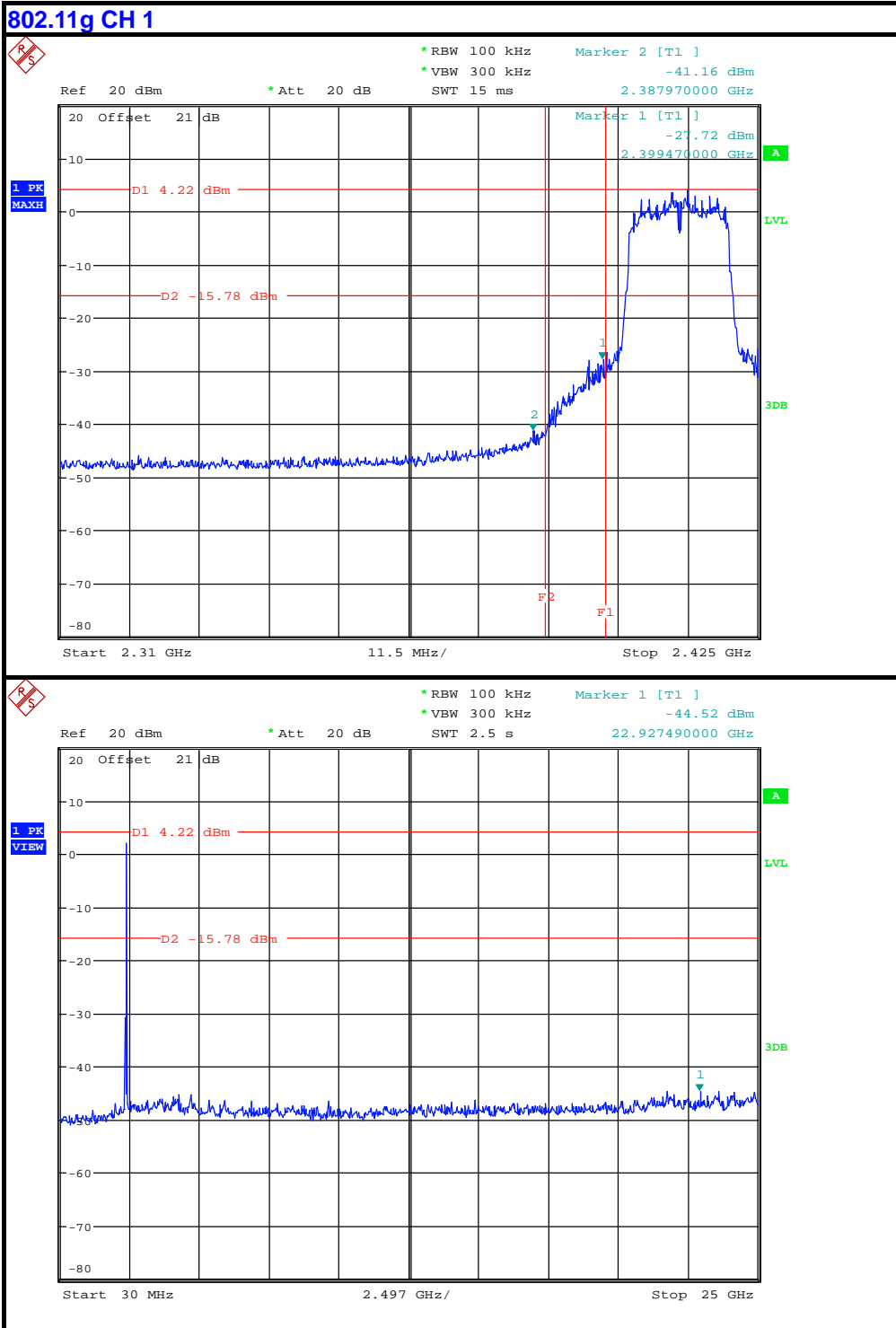

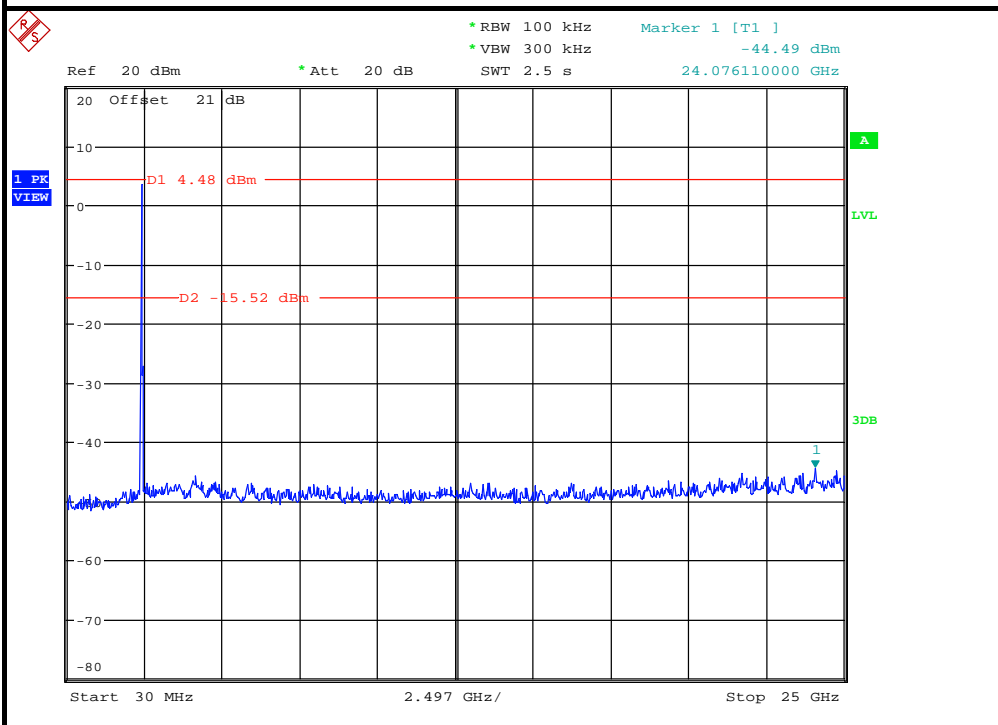
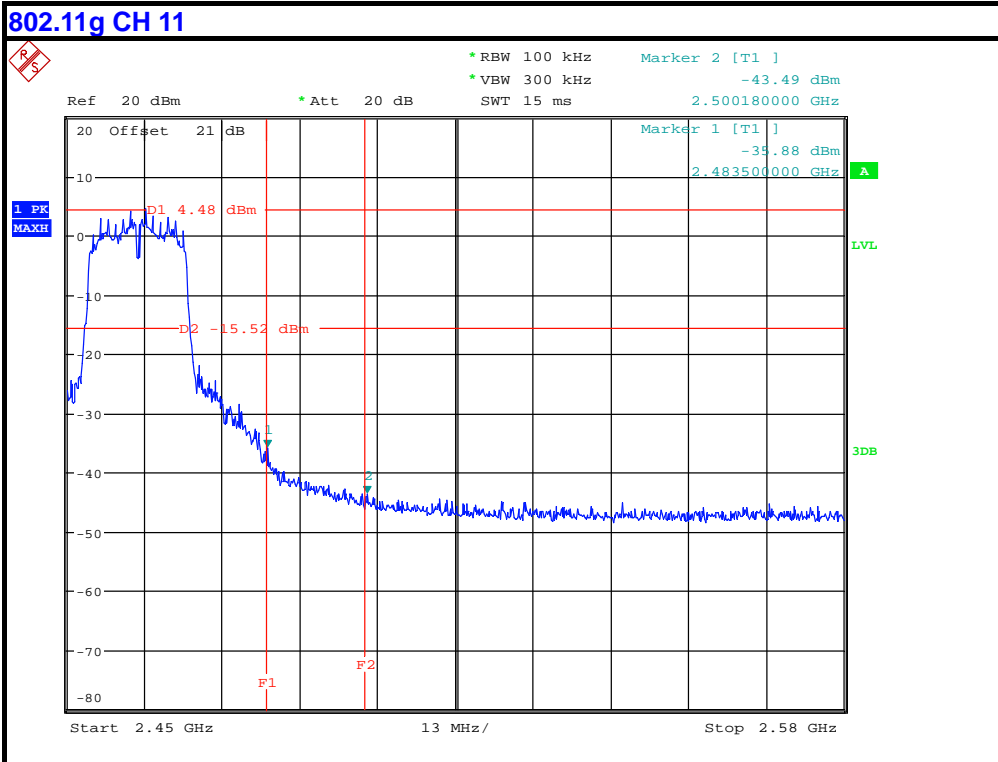

802.11n (20MHz) CH 1

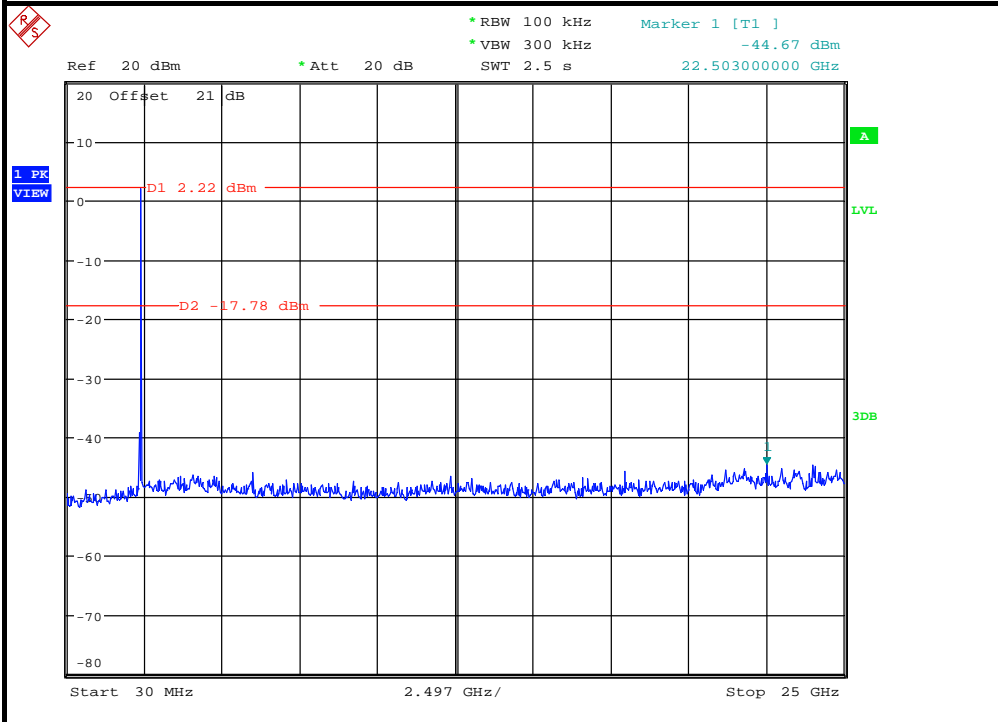
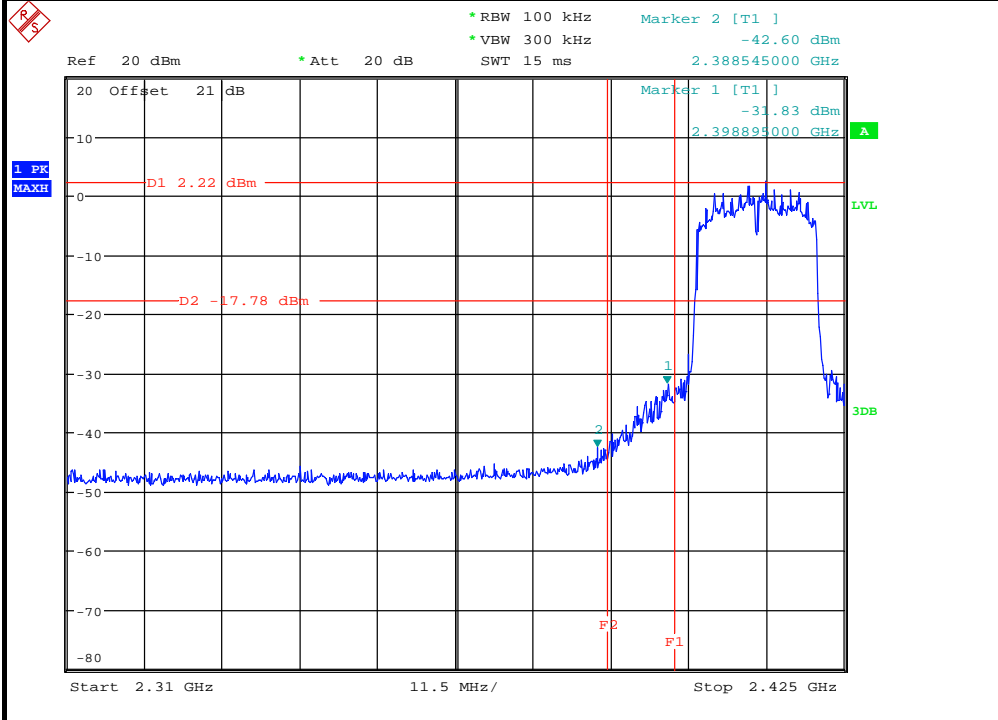

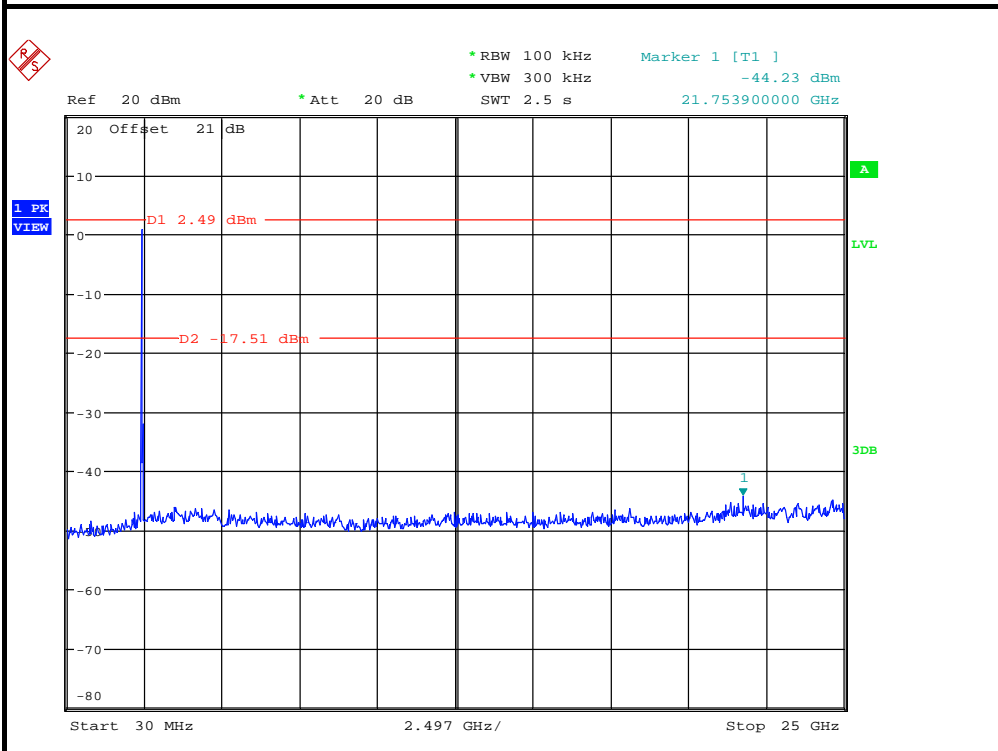
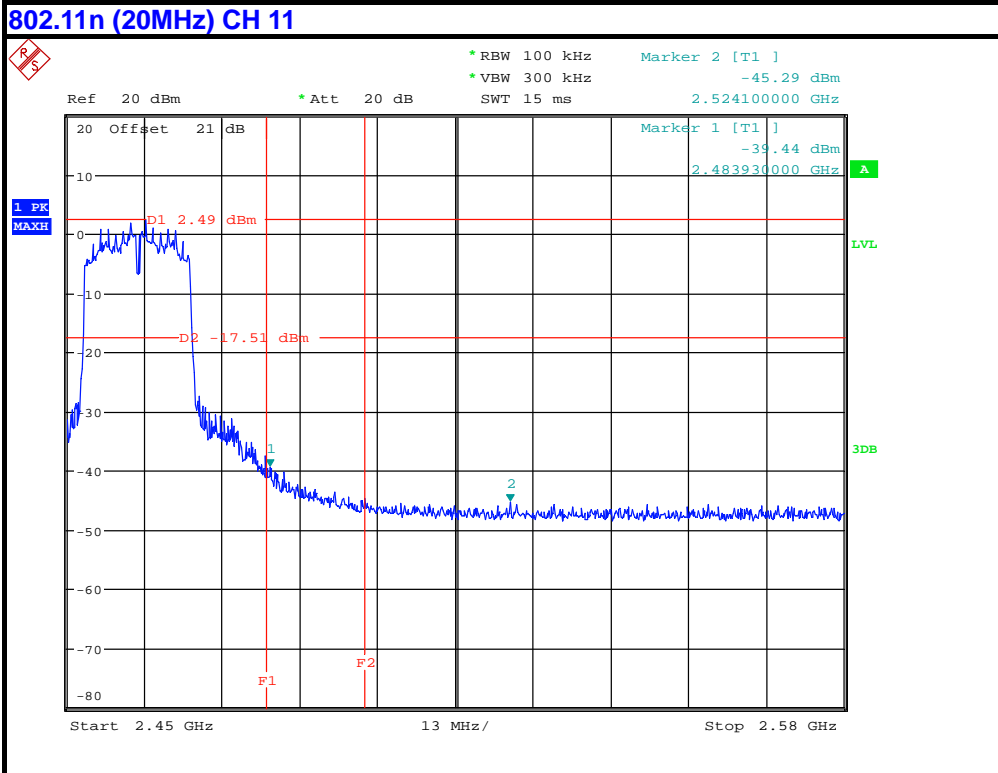



A D T

5. PHOTOGRAPHS OF THE TEST CONFIGURATION

Please refer to the attached file (Test Setup Photo).



A D T

6. INFORMATION ON THE TESTING LABORATORIES

We, Bureau Veritas Consumer Products Services (H.K.) Ltd., Taoyuan Branch, were founded in 1988 to provide our best service in EMC, Radio, Telecom and Safety consultation. Our laboratories are accredited and approved according to ISO/IEC 17025.

Copies of accreditation and authorization certificates of our laboratories obtained from approval agencies can be downloaded from our web site:

www.adt.com.tw/index.5.phtml. If you have any comments, please feel free to contact us at the following:

Linko EMC/RF Lab

Tel: 886-2-26052180

Fax: 886-2-26051924

Hsin Chu EMC/RF Lab

Tel: 886-3-5935343

Fax: 886-3-5935342

Hwa Ya EMC/RF/Safety/Telecom Lab

Tel: 886-3-3183232

Fax: 886-3-3270892

Email: service.adt@tw.bureauveritas.com

Web Site: www.adt.com.tw

The address and road map of all our labs can be found in our web site also.



A D T

7. APPENDIX A - MODIFICATIONS RECORDERS FOR ENGINEERING CHANGES TO THE EUT BY THE LAB

No modifications were made to the EUT by the lab during the test.

---END---