

Outdoor RRU
IronRAN-RU4 MO GenA
(3550 ~ 3700 MHz)
User Manual



Version: 1.0

Copyright

Copyright © 2022. This publication, including all photographs, illustrations and software, is protected under international copyright laws, with all rights reserved. Neither this guide, nor any of the material contained herein, may be reproduced without the express written consent of the manufacturer. All trademarks and logos are copyrights of their respective owners.

Version 1.0 / October 26, 2022

Disclaimer

The information in this document is subject to change without notice. The manufacturer makes no representations or warranties with respect to the contents hereof and specifically disclaims any implied warranties of merchantability or fitness for any particular purpose. Furthermore, the manufacturer reserves the right to revise this publication and to make changes from time to time in the content hereof without obligation of the manufacturer to notify any person of such revision or changes.

All the illustrations in this guide are for reference only and are subject to change without prior notice.

TABLE OF CONTENTS

Chapter 1. About the System

Introduction	1-1
Specifications	1-1
Radio Function Specifications.....	1-2
Shipping Package	1-3
Accessories	1-3
IronRAN-RU4 MO GenA FRU (Field-Replaceable Unit) Part List ...	1-3
Required Tools.....	1-4
A Tour of the System	1-5
System Overview.....	1-5
System Top View.....	1-5
System Bottom View	1-6
System Rear View	1-7
System Dimensions	1-8

Chapter 2. Installing Hardware

Introduction	2-1
Safety Instructions.....	2-1
Hardware Installation.....	2-2
ESD Precautions.....	2-2
Component and Tool Information	2-2
Installing Bracket A on Device.....	2-3
Installing the RRU on a Wall.....	2-3
Installing the RRU on a Pole.....	2-6
Connecting a Fiber-optic Cable	2-10
Disconnecting a Fiber-optic Cable	2-12

Chapter 3. Cabling Diagram

Cabling Diagram 3-1

Chapter 4. Regulatory & Compliance

Electromagnetic Compatibility Notices..... 4-1

- Restriction of Hazardous Substances (RoHS) Compliance 4-1
- End of Life / Product Recycling..... 4-1
- FCC Regulations..... 4-1
- RF Exposure Information..... 4-2

Product Regulatory Compliance Markings..... 4-3

Conventions

Several different typographic conventions are used throughout this manual. Refer to the following examples for common usage.

Bold type face denotes menu items, buttons and application names.

Italic type face denotes references to other sections, and the names of the folders, menus, programs, and files.



WARNING!

Warning information appears before the text it references and should not be ignored as the content may prevent damage to the device.



CAUTION!

Cautions appear before the text it references, similar to notes and warnings. cautions, however, appear in capital letters and contain vital health and safety information.

Note:

Highlights general or useful information and tips.

IronRAN-RU4 MO GenA Precautionary Measures

Read all caution and safety statements in this document before performing any of the instructions. To reduce the risk of bodily injury, electrical shock, fire, and equipment damage, read and observe all warnings and precautions in this chapter before installing or maintaining your system. To avoid personal injury or property damage, before you begin installing the product, read, observe, and adhere to all of the following instructions and information. The following symbols may be used throughout this guide and may be marked on the product and / or the product packaging.

Safety Instructions about your system



In the event of a conflict between the information in this guide and information provided with the product or on the website for a particular product, the product documentation takes precedence.

Your system should be integrated and serviced only by technically qualified persons.

You must adhere to the guidelines in this guide and the assembly instructions in related chapters to ensure and maintain compliance with existing product certifications and approvals. Use only the described, regulated components specified in this guide. Use of other products / components will void other regulatory approvals of the product, and may result in noncompliance with product regulations in the region(s) in which the product is sold.

A residual current protective device (RCD) with rated residual operating current not exceeding 30mA shall be used in the mains supply to socket-outlets intended for general use.

Warning and Cautions

CAUTION	Indicates the presence of a hazard that may cause minor personal injury or property damage if the CAUTION is ignored.
WARNING	Indicates the presence of a hazard that may result in serious personal injury if the WARNING is ignored.
	Indicates potential hazard if indicated information is ignored.
	Indicates shock hazards that result in serious injury or death if safety instructions are not followed.
	Indicates hot components or surfaces.

Warning and Cautions (Continued)

	<p>The system is intended for installation only in Restricted Access Locations:</p> <ul style="list-style-type: none"> • access can only be gained by SERVICE PERSONS or by USERS who have been instructed about the reasons for the restrictions applied to the location and about any precautions that shall be taken; and • access is through the use of a TOOL or lock and key, or other means of security, and is controlled by the authority responsible for the location.
---	---

Site Selection

Choose a site that is:

- Away from sources of vibration or physical shock.
- Isolated from strong electromagnetic fields produced by electrical devices.
- Provided with a properly grounded wall outlet.
- Provided with sufficient space to access the power system.

Equipment Handling Practices

Reduce the risk of personal injury or equipment damage:

- Conform to local occupational health and safety requirements when moving and lifting equipment.
- Use mechanical assistance or other suitable assistance when moving and lifting equipment.
- To reduce the weight for easier handling, remove any easily detachable components.
- Never lift or move your system solely by the handle on the component.
- The power supply cord(s) must be plugged into the socket-outlet(s) that is / are provided with a suitable earth ground.
- Laser Class 1 optical transceiver shall be used only.
- This is a Class 1 Laser product. Use only IEC 60825-1 certified Optical Fiber Transceiver with minimum operating temperature at 75 degree C.
- Never open the equipment. For safety reasons, the equipment should be opened only by qualified skilled personnel.
- The system can't be hosed down or splashed with water.

Power and Electrical Warnings



CAUTION!

Double Pole / Neutral Fusing.



CAUTION!

Must use current limiting type circuit breaker, peak current < 300 A.



CAUTION!

Make sure the system is removed from the pole or wall before servicing any components.



CAUTION!

To avoid risk of electric shock, disconnect all cabling from the system and remove the system from the pole or wall.



CAUTION!

For IronRAN-RU4 MO GenA devices stored in -40°C environments for over 1 hour, a warm up period of 1.5 hours is required before cell connection.

System Access Warnings



CAUTION!

To avoid personal injury or property damage, the following safety instructions apply whenever accessing the inside of the product:

- Disconnect from the power source by removing the system from the pole or wall.
- Disconnect all cabling running into the system.
- Retain all screws or other fasteners when servicing. Upon completion servicing, secure with original screws or fasteners.



CAUTION!

If the system has been running, any installed components may be hot.



CAUTION!

Unless you are adding or removing a hot-plug component, allow the system to cool before servicing.



CAUTION!

To avoid injury do not contact moving fan blades. If your system is supplied with a guard over the fan, do not operate the system without the fan guard in place.

Electrostatic Discharge (ESD)



CAUTION!

ESD can damage drives, boards, and other parts. We recommend that you perform all procedures at an ESD workstation. If one is not available, provide some ESD protection by wearing an anti-static wrist strap attached to chassis ground -- any unpainted metal surface -- on your device when handling parts.

Always handle boards carefully. They can be extremely sensitive to ESD. Hold boards only by their edges without any component and pin touching. After removing a board from its protective wrapper or from the system, place the board component side up on a grounded, static free surface. Use a conductive foam pad if available but not the board wrapper. Do not slide board over any surface.

Cooling and Airflow



CAUTION!

Carefully route cables as directed to minimize airflow blockage* and cooling problems. For proper cooling and airflow*, operate the system only with the chassis covers* / air duct* installed. Operating the system without the covers / air duct* in place can damage system parts. To install the covers* / air duct*:

Check first to make sure you have not left loose tools or parts inside the system.

- Check that cables, add-in cards, and other components are properly installed.

Attach the covers* / air duct* to the chassis according to the product instructions.

* May not apply to all systems.

Please be aware that slots and openings on the front and rear side of the chassis are designed for ventilation; to make sure reliable operation of your system and to protect it from overheating, these openings must not be covered or blocked. The openings should never be covered or blocked by placing the product on a bed, sofa, rug, or other similar surface. This product should never be placed near or over a radiator or heat register, or in a built-in installation unless proper ventilation is provided.

Heed safety instructions: Before working with the system, whether using this manual or any other resource as a reference, pay close attention to the safety instructions. Adhere to the assembly instructions in this manual to ensure and maintain compliance with existing product certifications and approvals. Use only the described, regulated components specified in this manual. Use of other products / components will void other safety regulatory approvals of the product and will most likely result in non-compliance with product regulations in the region(s) in which the product is sold.

System power on/off: To remove power from system, you must remove the system from the pole or wall. Make sure the system is removed from the pole or wall before opening the chassis, adding, or removing any non hot-plug components.

Hazardous conditions, devices and cables: Hazardous electrical conditions may be present on power, telephone, and communication cables. Turn off the system and disconnect the cables attached to the system before servicing. Otherwise, personal injury or equipment damage can result.

Electrostatic discharge (ESD) and ESD protection: ESD can damage drives, boards, and other parts. We recommend that you perform all procedures in this chapter only at an ESD workstation. If one is not available, provide some ESD protection by wearing a nonconductive wrist strap attached to chassis ground (any unpainted metal surface on the device) when handling parts.

ESD and handling boards: Always handle boards carefully. They can be extremely sensitive to electrostatic discharge (ESD). Hold boards only by their edges. After removing a board from its protective wrapper or from the system, place the board component side up on a grounded, static free surface. Use a conductive foam pad if available but not the board wrapper. Do not slide board over any surface.

General Information

Before servicing this system, it is recommend to read this guide completely to be aware of any safety issues or requirements involved in the servicing of this system.

Assembly Safety Guidelines

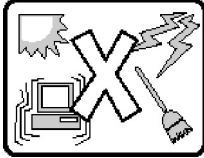

Choose a site that is:

- Away from sources of vibration or physical shock.
- Isolated from strong electromagnetic fields produced by electrical devices.
- In regions that are susceptible to electrical storms, we recommend you plug your system into a surge suppressor and disconnect telecommunication lines to your modem during an electrical storm.
- Provided with a properly grounded wall outlet.
- Provided with sufficient space to access the power system, because they serve as the product's main power disconnect.

About the System

Chapter 1

This section introduces the system, its different configuration(s) and the main features.

1.1 Introduction

Specifications

Table 1-1: Specifications

SPECIFICATIONS	DESCRIPTION
Memory	2GB DDR3
Power supply	110/220 AC In
Power consumption	Max. 180W
System rating	100-240Vac, 50/60Hz, 4.7A
Front IO	1 x AC Port 1 x SFP+ 10G 1 x Management port (RJ45) 1 x Console Port (RJ45)
Indicators	<ul style="list-style-type: none"> ● Power Status ● Working Status ● Warning Status ● SFP+ Status
Dimension	Without cage shade: 418.5 x 312 x 152 mm (16.48 x 12.28 x 5.99 in.) With cage shade: 418.5 x 355 x 165 mm (16.48 x 13.98 x 6.50 in.)
Weight	15 KG (33.06 lbs)
Fan	Fan-less design
Placement	Wall-mount, pole-mount
Surge protection	<ul style="list-style-type: none"> ● IEC 61000-4-5 Level 3 (2KV), performance criteria: A*¹ ● IEC 61000-4-5 Level 3 (4KV), performance criteria: A*¹ ● GR-1089 6KV, performance criteria: A*¹
Operating temperature	<ul style="list-style-type: none"> ● -40°C ~ +55°C (-40°F ~ +131°F): US*²
Operating humidity	RH 5% ~ 95%
Ingress protection	IP65
MTBF	> 100,000 hrs
Certification	US: FCC/CSA

*¹ Performance criteria A: Normal performance, Performance criteria C: System reset.

*² Please notice if IronRAN-RUx MO is placed in a -40°C environment for over 1 hour, warm up this device over 1.5 hours is required before cell connection.

Radio Function Specifications

Table 1-2: Radio Function Specifications

RF SPECIFICATIONS	DESCRIPTION
Frequency	n48 (3550MHz~3700MHz) n77/n78 (3550MHz~3700MHz)
Max. Carrier aggregation	1
Function split	O-RAN option 7-2x
Optical interface	1x SFP+ 10Gbps fronthaul eCPRI
Synchronization	IEEE 1588v2
MIMO	4T4R
Antenna type	External antenna (refer to Accessories page for beamwidth options)
Antenna port	4 x Antenna port (50Ω), N-Female
Output power	5W/channel; maximum output power: 4 x 5W (4T4R) US: 1.6W/channel; maximum output power: 4 x 1.6W (4T4R)
Frequency error	± 0.1 ppm
EVM	256 QAM < 3.5%
Linearization	CFR, DPD

Shipping Package

Table 1-3: IronRAN-RU4 MO GenA Shipping Package

ITEM	QPN	DESCRIPTION	QUANTITY	IMAGE	NOTES
Outdoor RRU	US:12REZZZ0004	IronRAN-RU4 MO GenA	1		Please confirm with region sales for SKU Option
Mounting kit (Pole Mount Kit)	1HY1ZZZ067E	Refer to mounting kit content	1		
10G Single mode transceiver	1HY1ZZZ067J	10G Single Mode Transceiver	2		
Crimp extraction tool for transceiver removal	1HY1ZZZ067D	Crimp extraction tool for transceiver removal	1		
Waterproof kit (RJ45)	1HY1ZZZ067H	Waterproof kit (RJ45)	1		Gland in shipping package with six options of OD size
Waterproof kit (SFP connector)	1HY1ZZZ067I	Waterproof kit (SFP connector)	1		Gland in shipping package with six options of OD size
Waterproof kit (power connector)	1HY1ZZZ072S	Waterproof kit (power connector)	1		Refer to cabling diagram for recommended power cord specification.

Accessories

IronRAN-RU4 MO GenA FRU (Field-Replaceable Unit) Part List

Table 1-4: IronRAN-RU4 MO GenA Accessories

ITEM	QPN	DESCRIPTION	MoQ
360° Antenna kit-7.5 dBi gain	1HY1ZZZ076A	360° Antenna-7.5 dBi gain	4
	1HY1ZZZ067F	360° Antenna mounting kit	1
	1HY1ZZZ067C	Antenna Cable	4
60° Antenna kit-12 dBi gain	1HY1ZZZ0789	60° Antenna-12 dBi gain	1
	1HY1ZZZ076B	60° Antenna mounting kit	1
	1HY1ZZZ067C	Antenna cable	4
65° Antenna kit-17 dBi gain	TBD	65° Antenna-17 dBi gain	1
	TBD	65° Antenna mounting kit	1
	TBD	Antenna cable	4
Mount kit	1HY1ZZZ067E	Pole mount Kit	1

Table 1-4: IronRAN-RU4 MO GenA Accessories (Continued)

ITEM	QPN	DESCRIPTION	MOQ
Accessory	1HY1ZZZ067J	10G Single mode transceiver	10
	1HY1ZZZ068M	Security key	10
	1HY1ZZZ067D	Crimp extraction tool for transceiver removal	10
	1HY1ZZZ067H	Waterproof kit (RJ45)	1
	1HY1ZZZ072S	Waterproof kit (power connector)	1
	1HY1ZZZ067I	Waterproof kit (SFP connector)	1

Required Tools

The following sections provides a reference for the tools to be prepared before installation.

Table 1-5: Required Tools

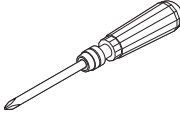
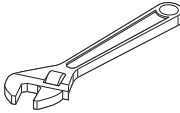
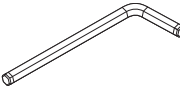
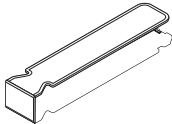
Item	Image	Quantity
Phillips #2 screwdriver		1
Adjustable wrench		2
Hex key H5		1
Crimp extraction tool for transceiver removal		1

1.2 A Tour of the System

System Overview

This section is intended to showcase the system views.



Figure 1-1. System Overview

System Top View

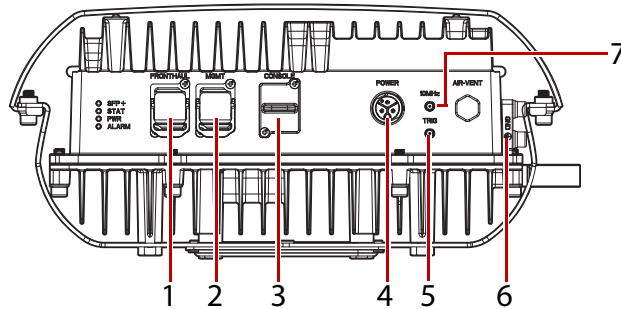

Figure 1-2. System Top View

Table 1-6: System Top View

No.	IO NAME / PORT	DESCRIPTION
1.	SFP+ port for FHGW	Fiber cable support FHGW to RRU, up to 2 KM
2.	Management port (RJ45)*	Port for network management
3.	Console port (RJ45)*	Waterproof dummy is provided in shipping
4.	Power port	Connection point for supplying power to the device
5.	TRIG*	Waterproof treatment is required on TRIG port to avoid rust

Table 1-6: System Top View (Continued)

No.	IO NAME / PORT	DESCRIPTION
6.	GND	Connection point for grounding the device
7.	10MHz*	Waterproof treatment, required on 10MHz port to avoid rust

*Unavailable for normal operations. For debugging by manufacturer only.

System Bottom View

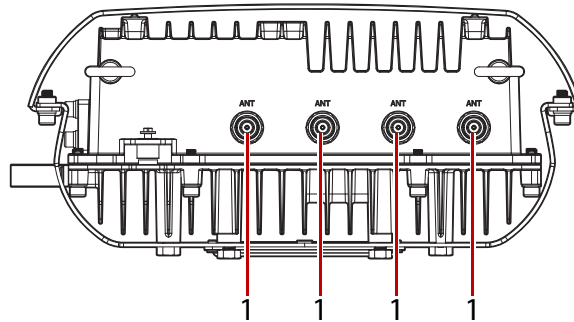

Figure 1-3. System Bottom View

Table 1-7: System Bottom View

No.	IO NAME / PORT	DESCRIPTION
1.	Antenna ports	4 x N-female connector to external antenna

System Indicators

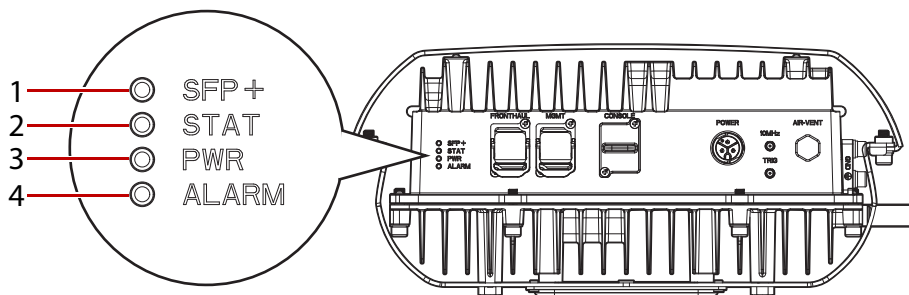

Figure 1-4. System Indicators

Table 1-8: System Indicators

No.	ITEM	COLOR	DESCRIPTION
1.	SFP+	Off	Indicates operating error in SFP+ module
		Green, solid	SFP+ module is installed successfully
		Green, flashing 0.5 Hz	SFP+ module is operating successfully

Table 1-8: System Indicators

No.	ITEM	COLOR	DESCRIPTION
2.	STAT	Green, flashing 1Hz	Indicates normal operating status
		STAT green, solid + alarm red, solid	Indicates system is activating
		Green, solid or off	Indicates a system hang and unable to control general purpose Input/output (GPIO)
3.	PWR	Off	Indicates power off and not operating
		Green, solid	Indicates power on
4.	Alarm	Off	Indicates normal operation
		Red, solid	Indicates a high system temperature error or unlocked phase-locked loop (PLL)

System Rear View

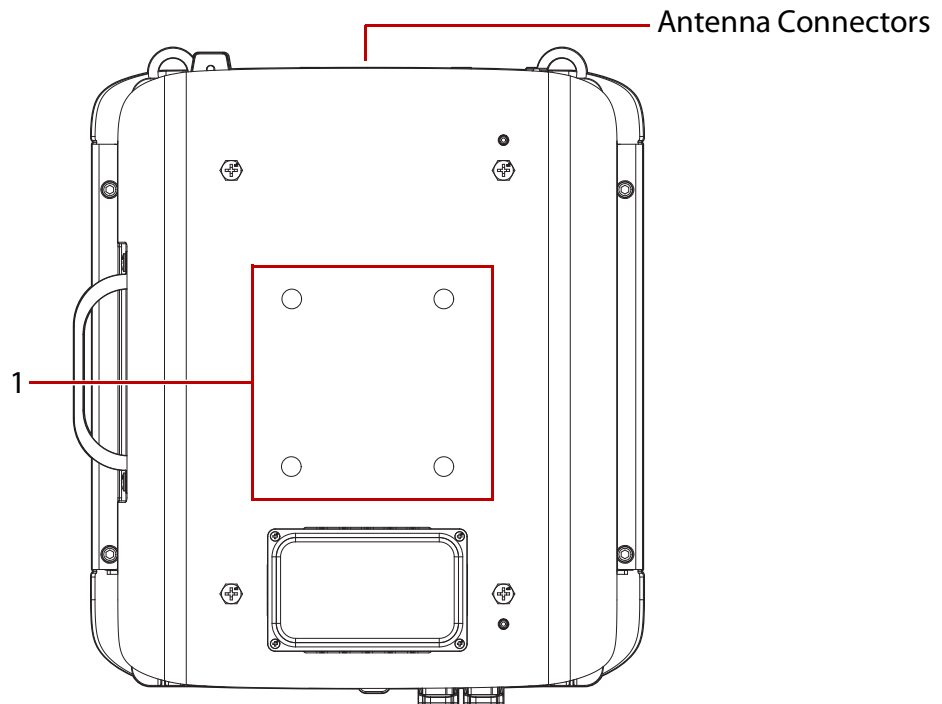

Figure 1-5. System Rear View

Table 1-9: Rear View

No.	ITEM
1.	Wall / ceiling mounting screw holes

System Dimensions

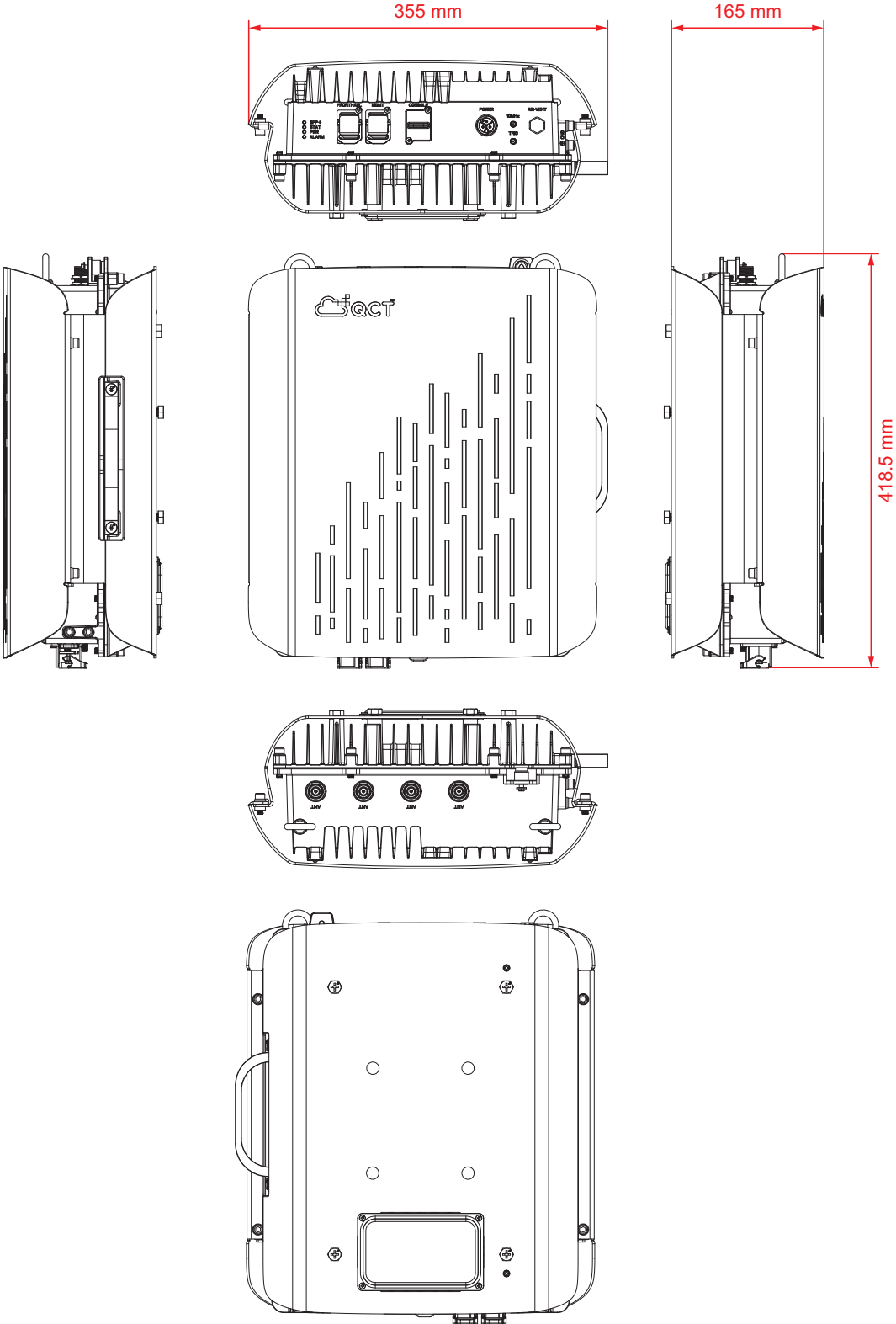

Figure 1-6. System Dimensions

Installing Hardware

Chapter 2

This section provides guidance information to properly service components in the system.

2.1 Introduction

The following section provides information for the setup and installation of the system.

Safety Instructions

**CAUTION!**

Many repairs may only be performed by a certified service technician. You should only perform troubleshooting and simple repairs as authorized in the product documentation. Damage due to servicing that is not authorized may not be covered by your warranty. Read and follow the safety instructions that came with the product.

Note:

It is recommended that you always use an anti static mat and strap while performing maintenance on the system.

2.2 Hardware Installation

The device can be either wall or ceiling mounted by design.



CAUTION!

Only trained service personnel should service this equipment.

ESD Precautions





When performing the following maintenance action, the following electrostatic discharge (ESD) precautions are recommended:

- Remove all plastic, vinyl, and foam material from the work area.
- Do not remove a component from its nonconductive protective bag until you are ready to install it.
- Wear a nonconductive wrist strap at all times when handling any component.
- Before handling any component, discharge any static electricity by touching a grounded surface.

Component and Tool Information

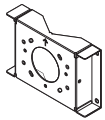
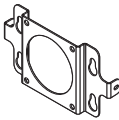
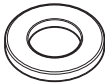
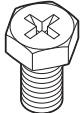
The following sections provides component and tool information.

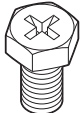
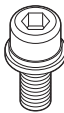
Table 2-1: Component and Tool Information

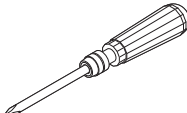
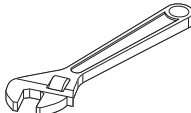
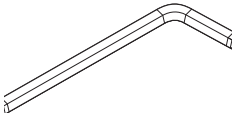
 <p>2RE System (1)</p>	 <p>Clamp A (2)</p>	 <p>Bracket A (1)</p>	 <p>Flat Washer A (8)</p>
	 <p>M8 A Screw (4), M8x15mm</p>	 <p>M8 B Screw (4), M8x12mm</p>	 <p>M10 A Screw (4), M10x200mm</p>
	 <p>M10 B Screw (4), M10x15mm</p>	 <p>M6 A Screw (2), M6x16mm</p>	 <p>Nut A (8), M10</p>
	 <p>Screw Driver #2 (1)</p>	 <p>Adjustable Spanner (2)</p>	 <p>Hex Key #H5 (1)</p>

Installing Bracket A on Device



CAUTION!

Ensure all power is disconnected from the system before proceeding.

Before you begin any procedure make sure the necessary components and tools are prepared. All screws must be tightened by using a Phillips #2 screwdriver.

1. Position the device so the antenna connectors are oriented as shown in the following figure.
2. Locate the mounting hole area on the device and align the bracket (A) over the screw holes. Ensure the directional marker (arrow) is pointing towards the antenna connectors signifying a correct bracket alignment.
3. Insert the M8 A screws to secure the bracket to the device.

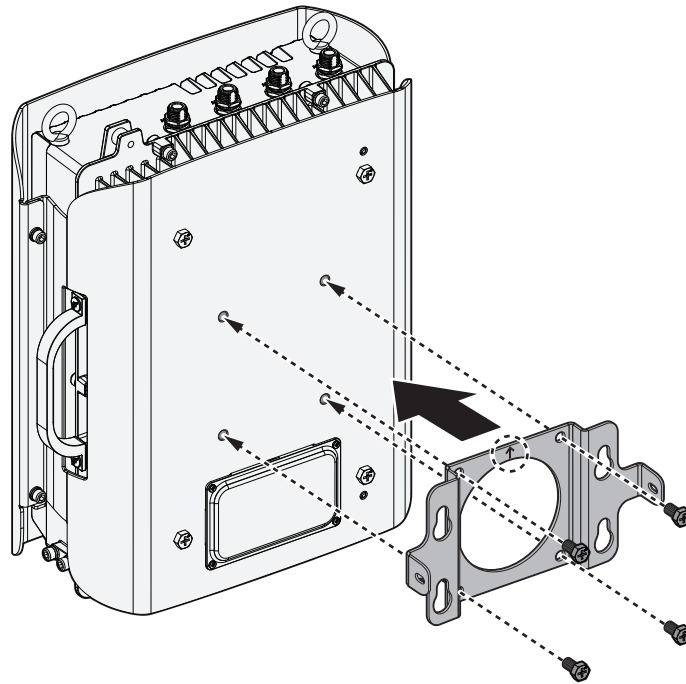

Figure 2-1. Installing Bracket A on Device

Once the bracket (A) is installed, the device can be mounted on a wall or pole.

Installing the RRU on a Wall



CAUTION!

Ensure all power is disconnected from the system before proceeding.

Before you begin any procedure make sure the necessary components and tools are prepared. All screws must be tightened by using a Phillips #2 screwdriver.

Fixing the device to a wall is a two step process. First the provided clamp (A) must be installed on the wall location. Then, the device is installed on the clamp.

Requirements:

- Install the bracket on the device. See *Installing Bracket A on Device* on page 2-3.
1. Position the clamp (A) over the wall location, making sure the arrow marking faces up, and mark the screw hole positions to serve as markers.
 2. Remove the clamp from the wall and drill holes on the marked locations.
 3. Insert wall sinks (not provided) in the drilled holes.
 4. Re-position the clamp on the wall and align the screw holes on the clamp over the drilled holes on the wall. Ensure the directional marker (arrow) is pointing upwards designating a correct bracket alignment.
 5. Secure the clamp with the M10 B screws.

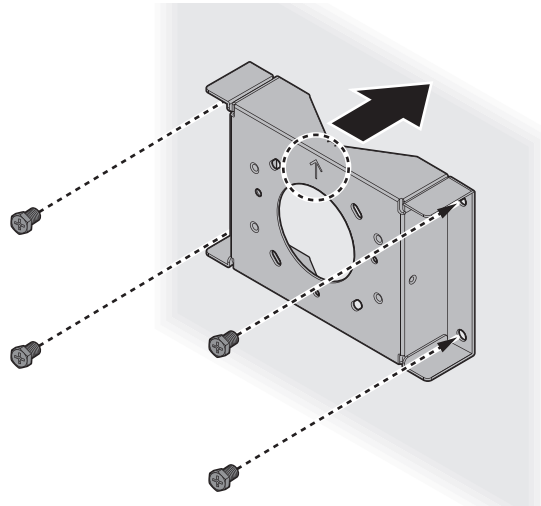

Figure 2-2. Installing a Clamp (A) on a Wall

6. Insert the M8 B guide screws in the mounting holes on the clamp.

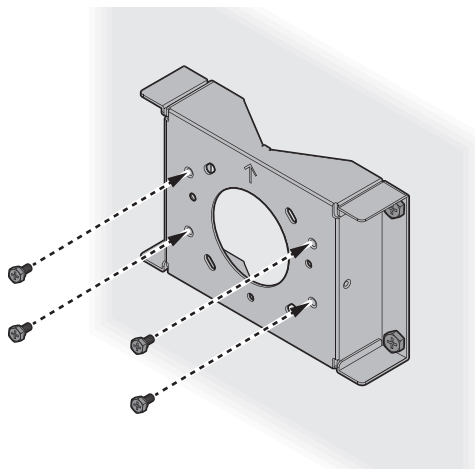

Figure 2-3. Installing Mounting Screws on a Clamp

7. Position the device on the clamp and align the keyholes on the bracket with the guide screws on the clamp.
8. Insert the keyholes on the bracket through the guide screws.
9. Once the bracket is inserted, slide the device downwards to lock the bracket to the clamp.

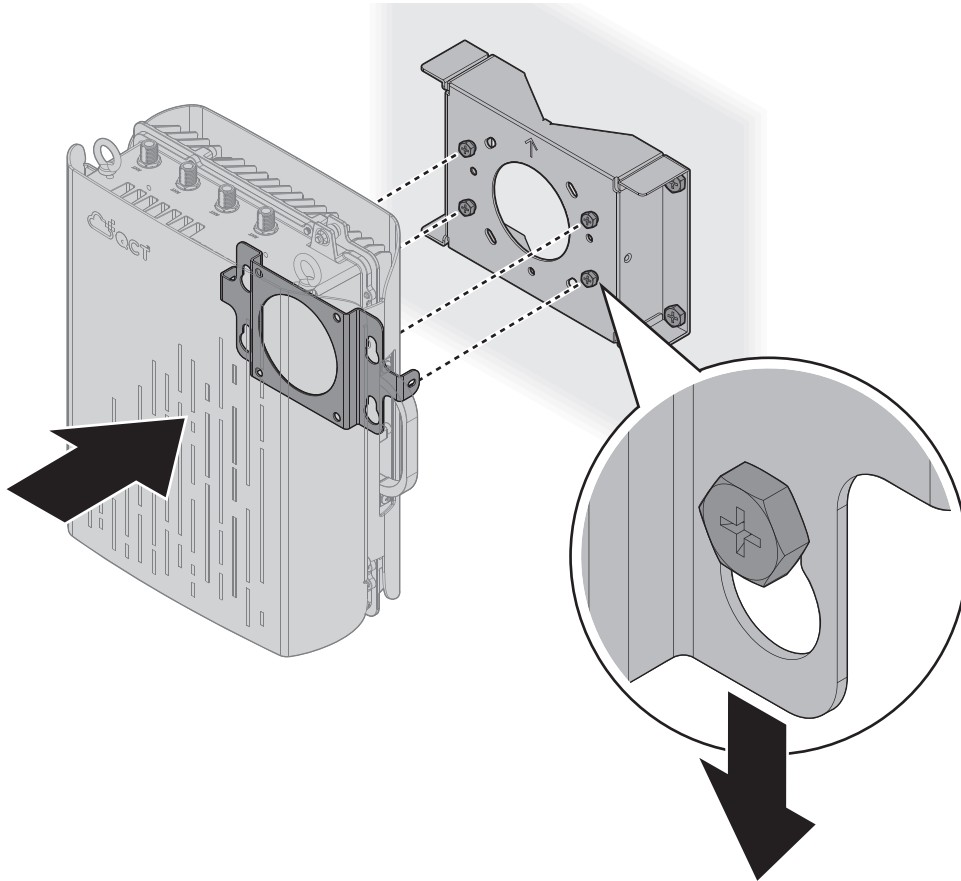

Figure 2-4. Installing a Device to a Wall Bracket (A)

10. Once the device is installed on the wall clamp, use the Hex Key to secure it with the M6 A screws.

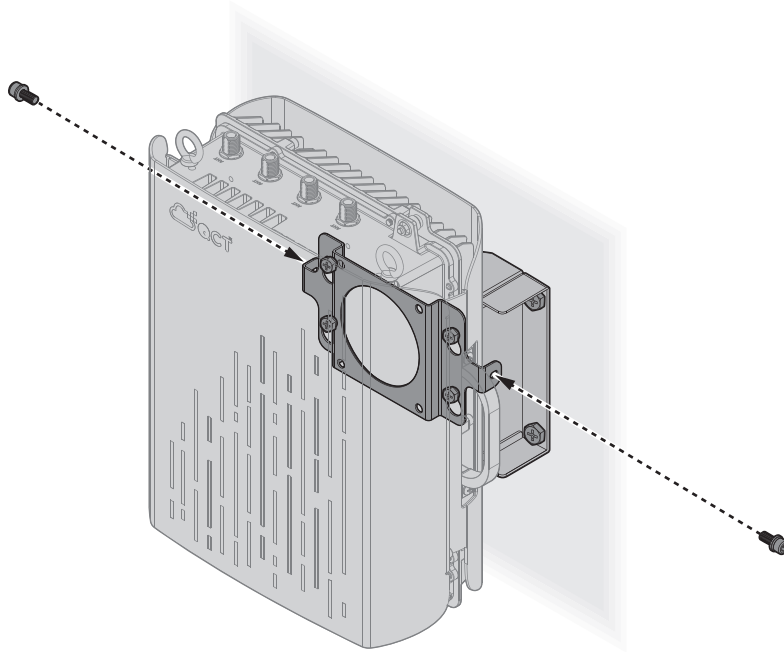

Figure 2-5. Securing Device to Wall Clamp

The device is now mounted to a wall.

Installing the RRU on a Pole



CAUTION!

Ensure all power is disconnected from the system before proceeding.

Before you begin any procedure make sure the necessary components and tools are prepared. All screws must be tightened by using a Phillips #2 screwdriver.

Fixing the device to a pole is a two step process. First the provided clamp (A) must be installed on the pole location. Then, the device is installed on the clamp.

Requirements:

- Install the bracket on the device. See *Installing Bracket A on Device* on page 2-3.
1. Select a mounting location on a pole to mount the device. The device can be attached to a pole diameter of 5.1 to 20.1 cm (2 to 8 inches).
 2. Hold both Clamps A and hold them against the pole. Ensure the directional marker (arrow) is pointing upwards designating a correct bracket alignment.

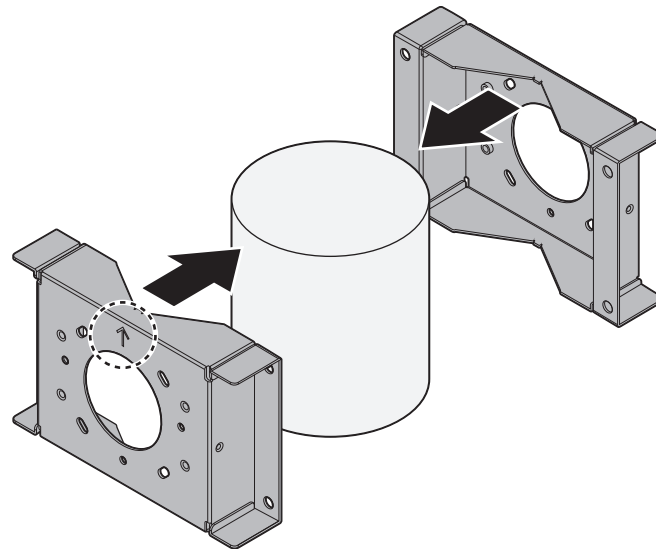

Figure 2-6. Positioning Clamps on a Pole

3. Slide the four M10 A screws through the mounting slots on both brackets

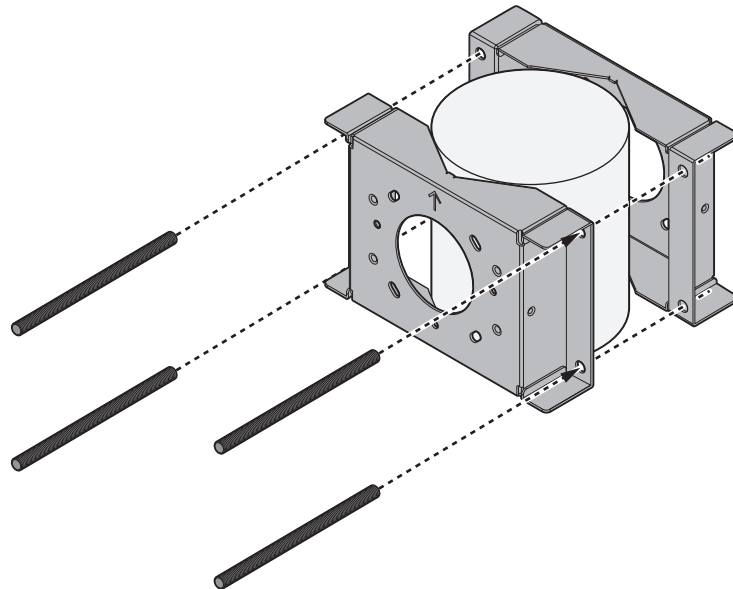

Figure 2-7. Inserting Mounting Bolts Through the Pole Clamps

4. Insert a Washer A and Nut A through each end of the bolts. Use a wrench to lightly tighten the bolts.

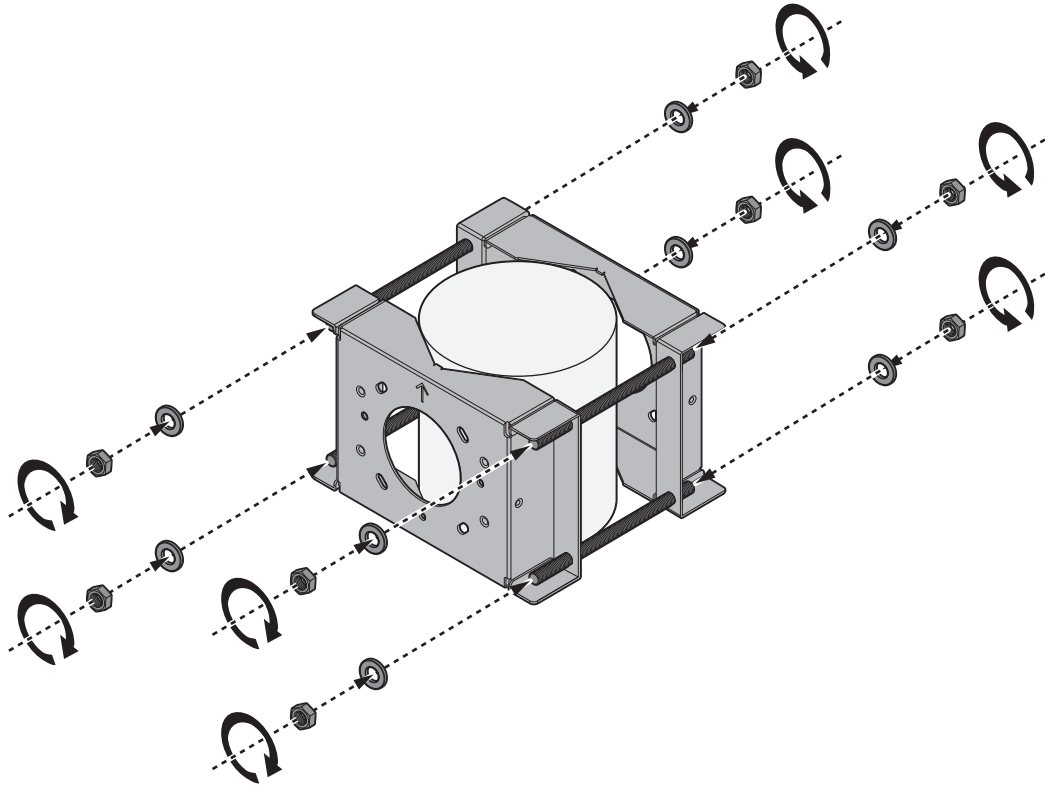

Figure 2-8. Fastening the Clamps (A) on the Pole

5. Position the assembly to its final location. Check to be sure that the clamps are correctly seated on the pole.
6. Once the clamps are evenly aligned on the pole, use a spanner to tighten all the nuts as directed in the following figure to secure the clamps on the pole to a torque of 30 kgf-cm (26 lbf-in.). Ensure that the clamps are tight enough to prevent any movement.

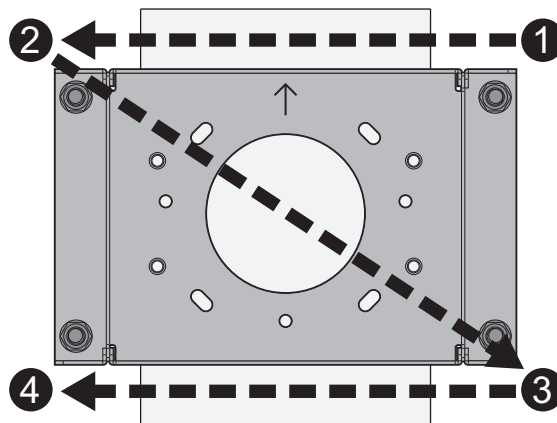

Figure 2-9. Securing the Clamps (A) on the Pole

7. Insert the M8 B guide screws in the mounting holes on the clamp.

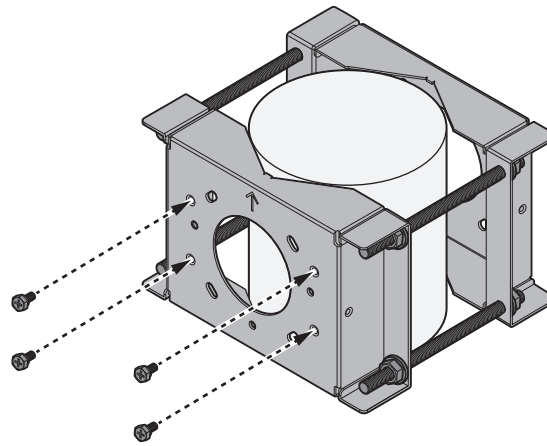

Figure 2-10. Installing Mounting Screws on Clamp

8. Position the device on the clamp and align the keyholes on the bracket with the guide screws on the clamp.
9. Insert the keyholes on the bracket through the guide screws.
10. Once the bracket is inserted, slide the device downwards to lock the bracket to the clamp.

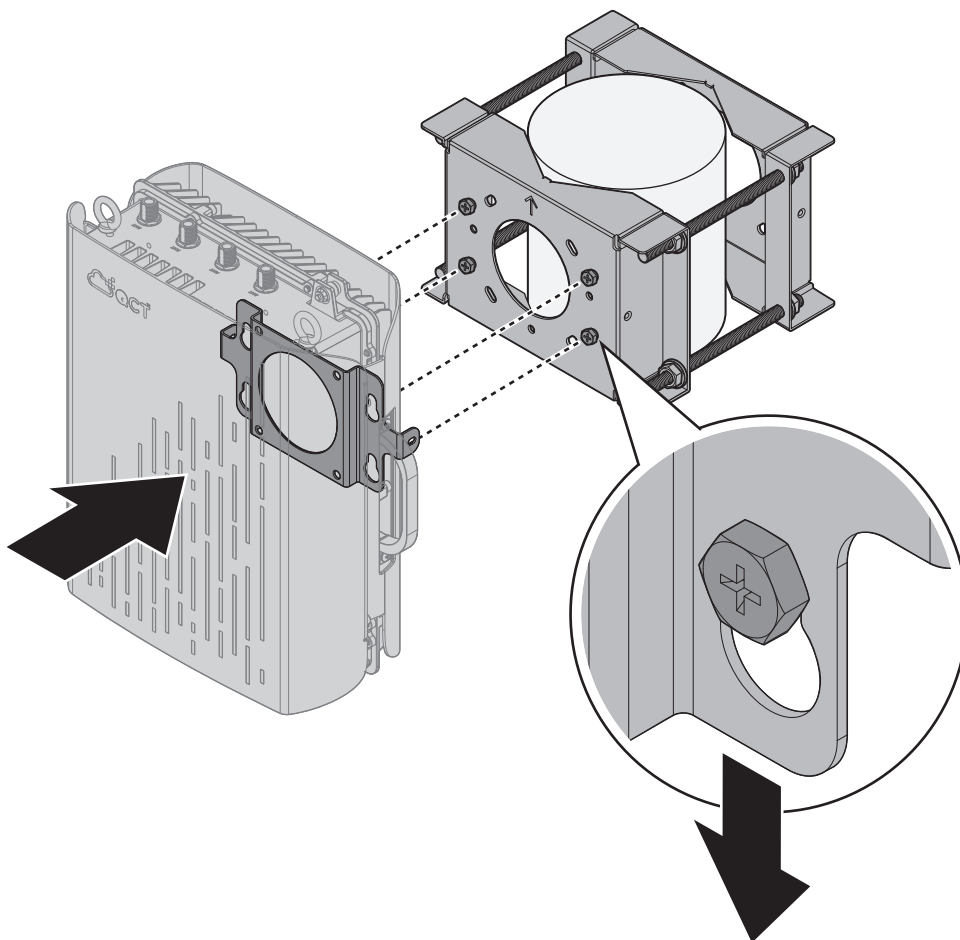

Figure 2-11. Installing a Device on a Pole Clamp (A)

11. Once the device is installed on the pole clamp, use a hex key to tighten the M6 A securing screw on the bracket and clamp.

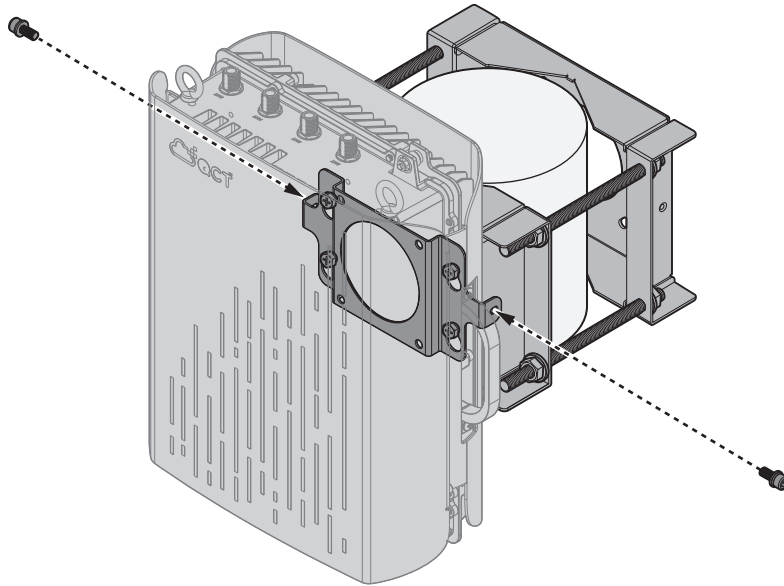

Figure 2-12. Securing Device to a Pole Clamp

The device is now mounted to a pole.

Connecting a Fiber-optic Cable



CAUTION!

Ensure all power is disconnected from the system before proceeding.

The device supports fiber-optic network connections.

Requirements:

- SFP module adapter
- Small form-factor pluggable (SFP) transceiver module
- SC or Duplex LC fiber-optic cables
- Waterproof kit

The fiber-optic networking cable can be connected to the SFP port. The SFP transceiver module connects the cable to the SFP port.

To connect the fiber-optic cable, follow this procedure:

1. Ensure all power sources are disconnected from the device.
2. Remove the plug cover the SFP port by using the following guidelines:
 - a. Place the device down on its bottom side on a clean work surface.
 - b. Hold the device down firmly in place and remove the plug cover from the SFP port(s).
3. Position the gland body so it is right side up. The locking mechanism is positioned on top.

4. Turn the cap from the gland body and remove it.
5. Lift the locking mechanism to unlock the protective cap at the end of the gland body, and remove the cap.
6. Before inserting a cable, disassemble the gland cap, the gland seal, and gland rubber from the gland body.
7. Assemble the cable in the gland body using the following guidelines:
 - a. Split the connector into two separate LC connector.
 - b. Slide gland cap into the cable.
 - c. Insert the gland seal over the cable.
 - d. Insert the gland rubber over the cable.
8. Insert the wire with the connector into the cable gland. Insert the second wire in the same manner.
9. Before proceeding make sure the SFP transceiver is installed in the device. Connect the cable to the SFP transceiver. Ensure an audible click sounds signifying a correct installation.

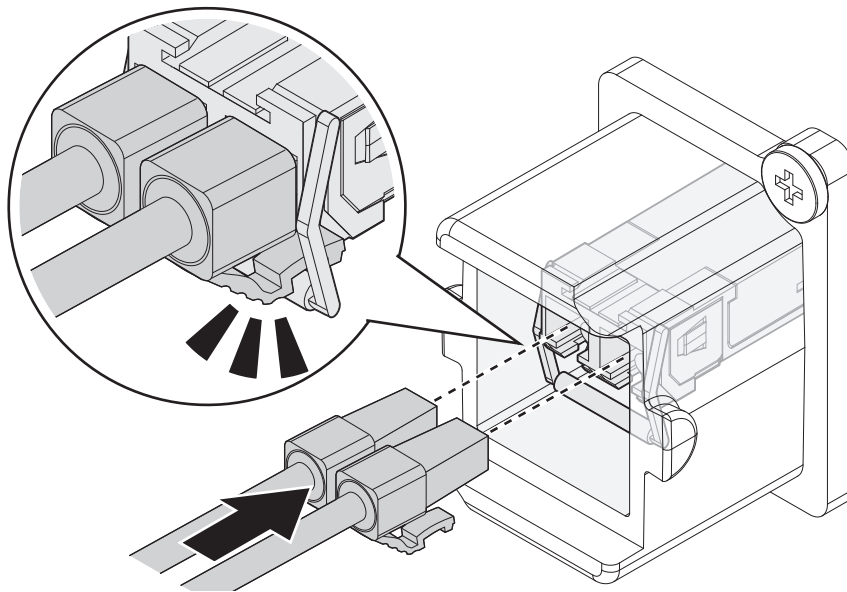

Figure 2-13. Connecting the Fiber Cable to the SFP Transceiver

10. Slide the gland body assembly into the SFP port until it is flush in the port.
11. Slide the gland rubber, gland seal, and gland cap into the gland body. Ensure there is no excess cable. The waterproof gland is flush in the SFP port when seated correctly.
12. Close the locking mechanism on the gland body to lock the gland body in place.
13. Tighten the gland cap. If necessary, use a wrench to tighten to a torque of 2 ~ 2.5 N-m (17.70 ~ 22.17 lbf-in.).

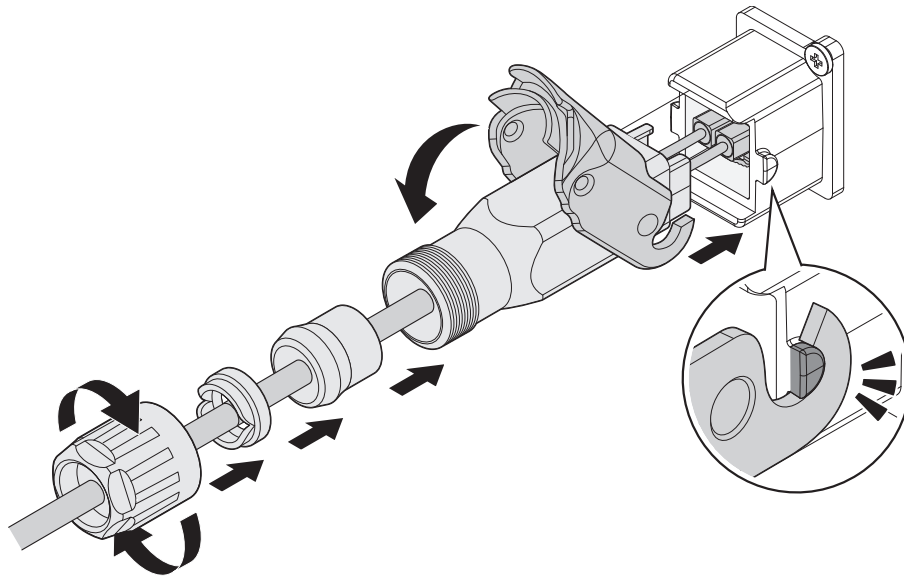

Figure 2-14. Connecting the Fiber Cable to the SFP Transceiver

Disconnecting a Fiber-optic Cable



CAUTION!

Ensure all power is disconnected from the system before proceeding.

The device supports fiber-optic network connections.

Requirements:

- SFP module adapter
- Small form-factor pluggable (SFP) transceiver module
- SC or Duplex LC fiber-optic cables
- Crimp extraction tool
- Waterproof kit

The fiber-optic networking cable can be connected to the SFP port. The SFP transceiver module connects the cable to the SFP port.

To disconnect the fiber-optic cable, follow this procedure:

1. Ensure all power sources are disconnected from the device.
2. Locate the SFP port on the device and turn the protective cap on the gland body to release it from the gland body.
3. Slide out the gland seal and gland rubber from the gland body.
4. Grasp the locking mechanism and lift it up to unlock the gland body from the device.
5. Slide out the gland body from the SFP port.

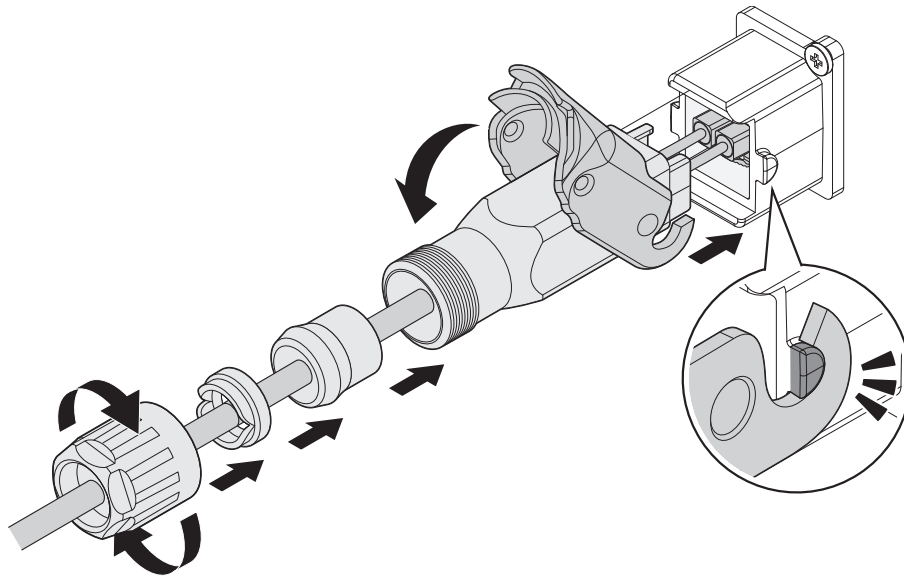

Figure 2-15. Removing the Weather Proofing Kit and Cable from the SFP Transceiver

6. Using a crimp extraction tool, reach into the SFP port and press the two plastic tabs located on either side of the fiber cable wires.
7. Remove the fiber cable from the SFP port.

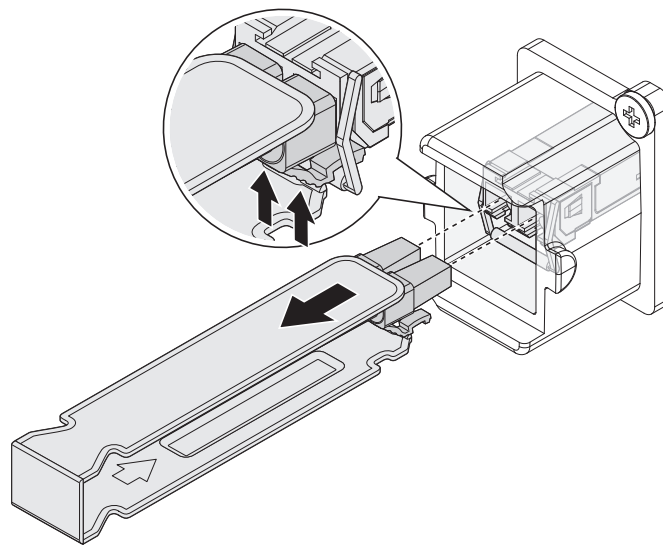

Figure 2-16. Disconnecting the Fiber Cable from the SFP Transceiver

8. Using a crimp extraction tool, reach into the SFP port and grasp the transceiver latch to pull out the module from the SFP port.

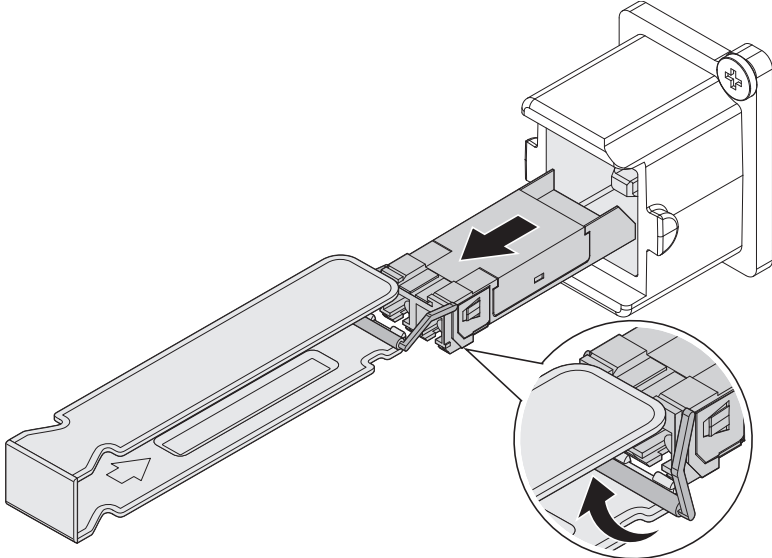

Figure 2-17. Disconnecting the SFP Transceiver from the SFP Port

- 9. The transceiver module should be placed in an antistatic bag.

Cabling Diagram

Chapter 3

This section provides guidance information for the position and configuration of connectors and jumpers.

3.1 Cabling Diagram

See the following figure and table for information on cable connections.

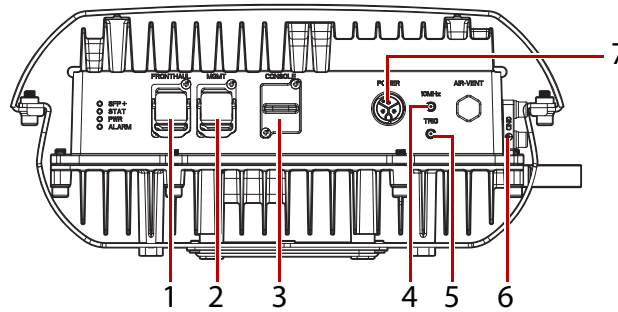

Figure 3-1. Front I/O Cable Diagram

No.	I/O NAME	DESCRIPTION	CABLE SPECIFICATIONS (SHIPPING EXCLUDING)
1.	SFP+ port for FHGW	Fiber cable support FHGW to RRU up to 2 KM	Waterproof fiber cable is required for outdoor deployment
2.	Management port*	N/A	N/A
3.	Console port (RJ45)*	Waterproof dummy is provided in shipping.	N/A
4.	10MHz*	Waterproof treatment, required on 10MHz port to avoid rust	No cable connection required
5.	TRIG*	Waterproof treatment is required on TRIG port to avoid rust	No cable connection required
6.	GND	Connection point for grounding the device	Ground cable with 16 AWG
7.	Power port	Connection point for supplying power to the device	Power cord supports up to 100M (110/220 AC in, OD: 9.3 mm)

*Unavailable for normal operations. For debugging by manufacturer only.

Regulatory & Compliance

Chapter 4

This section provides regulatory and compliance information applicable to this system.

4.1 Electromagnetic Compatibility Notices



WARNING!

This is a Class A information technology equipment. When used in a residential environment, it may cause radio frequency disturbance. In this case, the user will be required to take some appropriate countermeasures, in which case the user will be required to correct the interference.

Restriction of Hazardous Substances (RoHS) Compliance

It has a system in place to restrict the use of banned substances in accordance with the European Directive 2011/65/EU. Compliance is based on declaration that materials banned in the RoHS Directive are either (1) below all applicable threshold limits or (2) an approved / pending RoHS exemption applies.

RoHS implementation details are not fully defined and may change.

Threshold limits and banned substances are noted below:

- Quantity limit of 0.1% by mass (1000 PPM) for:
 - Lead
 - Mercury
 - Hexavalent Chromium
 - Polybrominated Biphenyls Diphenyl Ethers (PBDE)
- Limit of 0.01% by mass (100 PPM) for:
 - Cadmium

End of Life / Product Recycling

Product recycling and end-of-life take-back systems and requirements vary by country. Contact the retailer or distributor of this product for information about product recycling and / or take-back.

FCC Regulations

This device complies with part 15 of the FCC Rules. Operation is subject to the following two conditions: (1) This device may not cause harmful interference, and (2) this device must accept any interference received, including interference that may cause undesired operation.

Changes or modifications not expressly approved by the party responsible for compliance could void the user's authority to operate the equipment.

This equipment has been tested and found to comply with the limits for a Class A digital device, pursuant to part 15 of the FCC Rules. These limits are designed to provide reasonable protection against harmful interference when the equipment is operated in a commercial environment. This equipment generates, uses, and can radiate radio frequency energy and, if not installed and used in accordance with the instruction manual, may cause harmful interference to radio communications. Operation of this equipment in a residential area is likely to cause harmful interference in which case the user will be required to correct the interference at his own expense.

This device must be fixed-mounted on outdoor permanent structures.

RF Exposure Information

This device has been tested and meets applicable limits for Radio Frequency (RF) exposure.

This equipment should be installed and operated with minimum distance 382 cm between the radiator & your body.

4.2 Product Regulatory Compliance Markings

This product is marked with the following product certification markings:

Table 4-1: Product Regulatory Compliance Markings

REGULATORY COMPLIANCE	REGION	MARKING
cCSAus	USA / Canada	
FCC Marking (Class A)	USA	<p>FCC ID: HFS-IRONRAN-RU4MO</p> <p>This device complies with Part 15 of the FCC Rules. Operation of this device is subject to the following two conditions:</p> <p>(1) This device may not cause harmful interference, and</p> <p>(2) This device must accept any interference received, including interference that may cause undesired operation.</p>