

Band Edge_Band17_5MHz_QPSK_RB1_24_CH23825

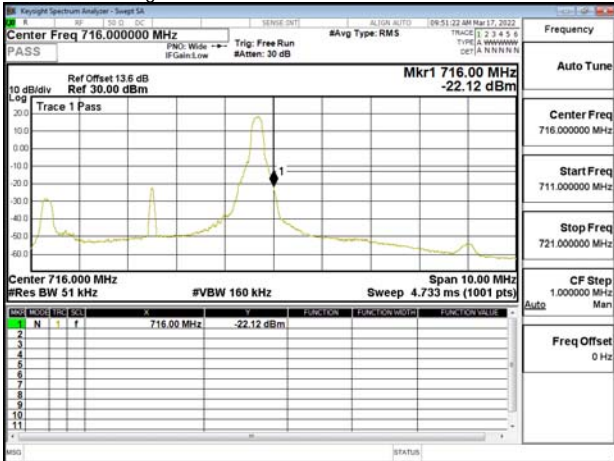

Band Edge_Band17_10MHz_QPSK_RB1_0_CH23780

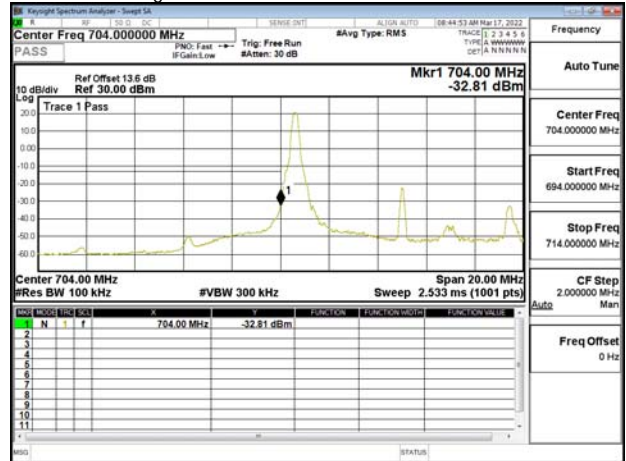

Band Edge_Band17_5MHz_QPSK_RB25_0_CH23755

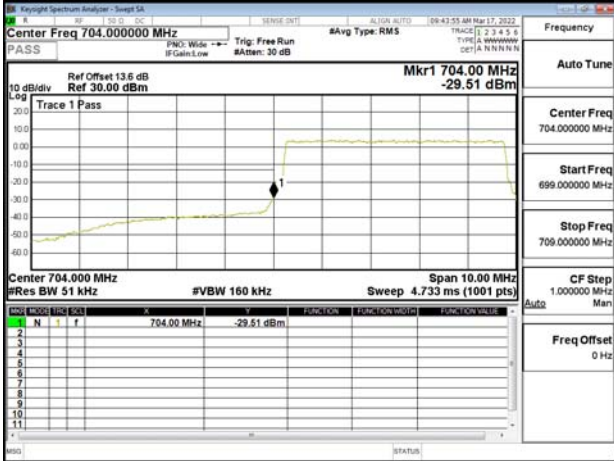

Band Edge_Band17_10MHz_QPSK_RB1_49_CH23800

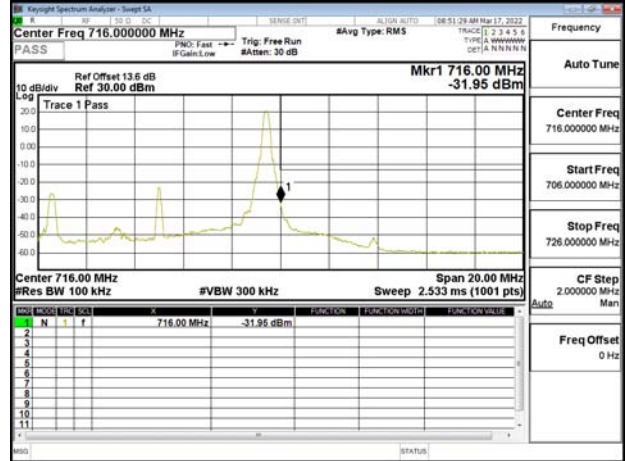

Band Edge_Band17_5MHz_QPSK_RB25_0_CH23825

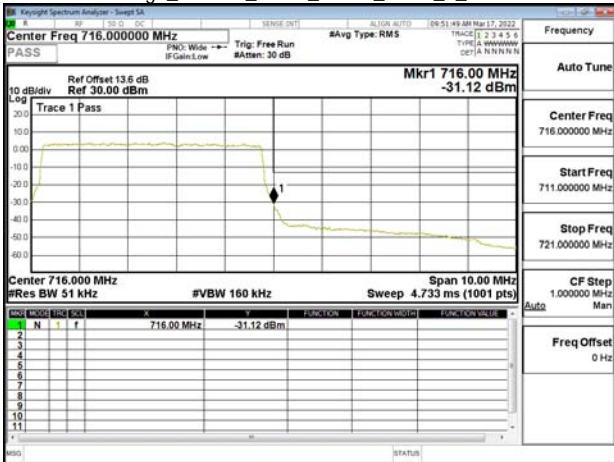

Band Edge_Band17_10MHz_QPSK_RB50_0_CH23780

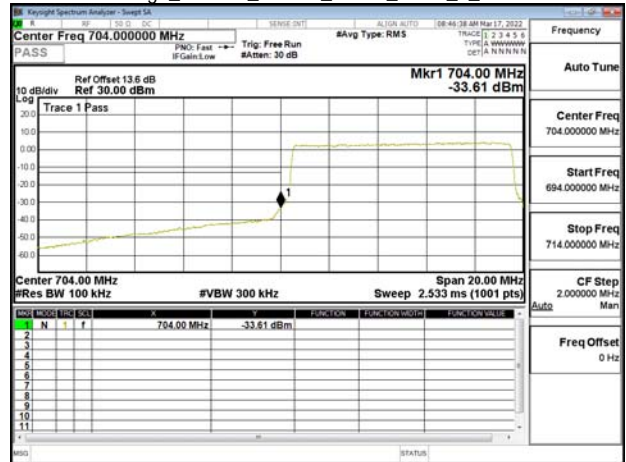

Unless otherwise stated the results shown in this test report refer only to the sample(s) tested and such sample(s) are retained for 90 days only.

除非另有說明，此報告結果僅對測試之樣品負責，同時此樣品僅保留90天。本報告未經本公司書面許可，不可部份複製。

This document is issued by the Company subject to its General Conditions of Service printed overleaf, available on request or accessible at <http://www.sgs.com.tw/Terms-and-Conditions> and for electronic format documents, subject to Terms and Conditions for Electronic Documents at <http://www.sgs.com.tw/Terms-and-Conditions>. Attention is drawn to the limitation of liability, indemnification and jurisdiction issues defined therein. Any holder of this document is advised that information contained herein reflects the Company's findings at the time of its intervention only and within the limits of Client's instructions, if any. The Company's sole responsibility is to its Client and this document does not exonerate parties to a transaction from exercising all their rights and obligations under the transaction documents. This document cannot be reproduced except in full, without prior written approval of the Company. Any unauthorized alteration, forgery or falsification of the content or appearance of this document is unlawful and offenders may be prosecuted to the fullest extent of the law.

Band Edge_Band17_10MHz_QPSK_RB50_0_CH23800

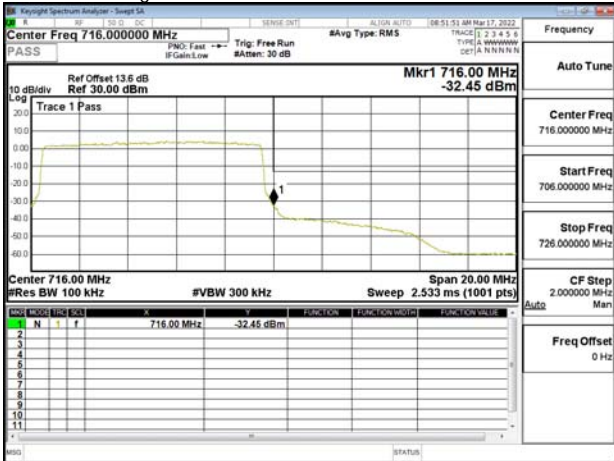

Band Edge_Band66_1.4MHz_QPSK_RB6_0_CH131979

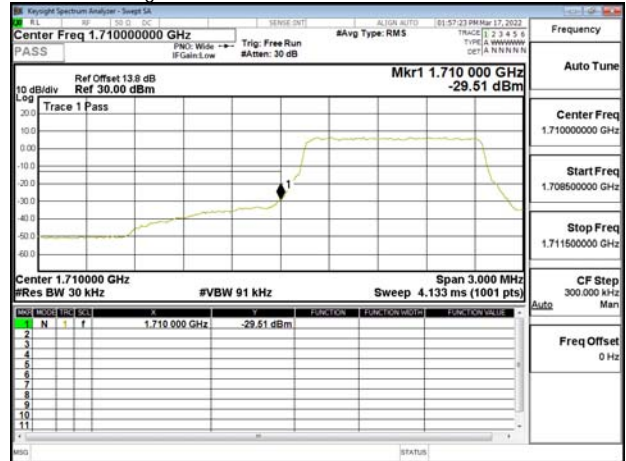

Band Edge_Band66_1.4MHz_QPSK_RB1_0_CH131979

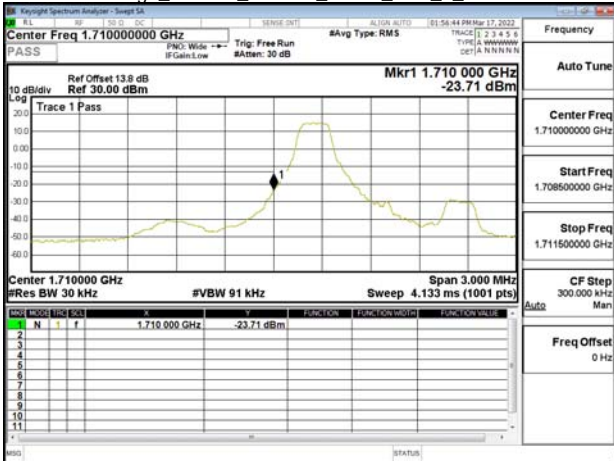

Band Edge_Band66_1.4MHz_QPSK_RB6_0_CH132665

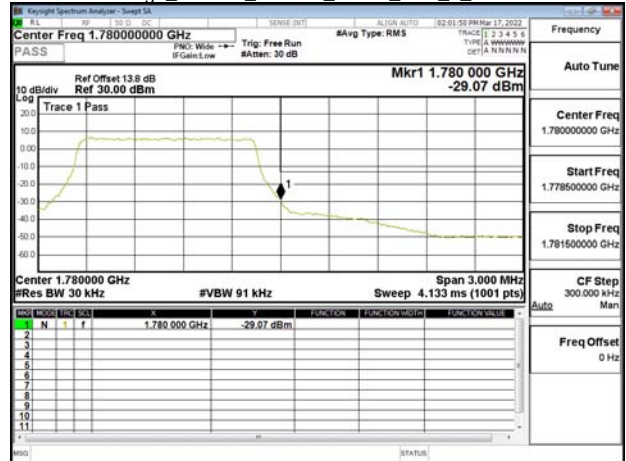

Band Edge_Band66_1.4MHz_QPSK_RB1_5_CH132665

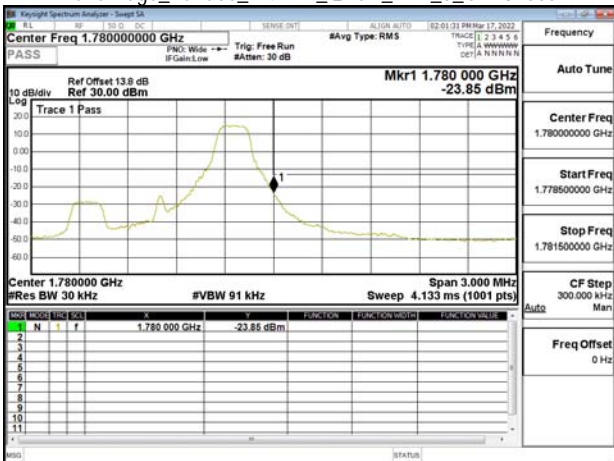

Band Edge_Band66_3MHz_QPSK_RB1_0_CH131987

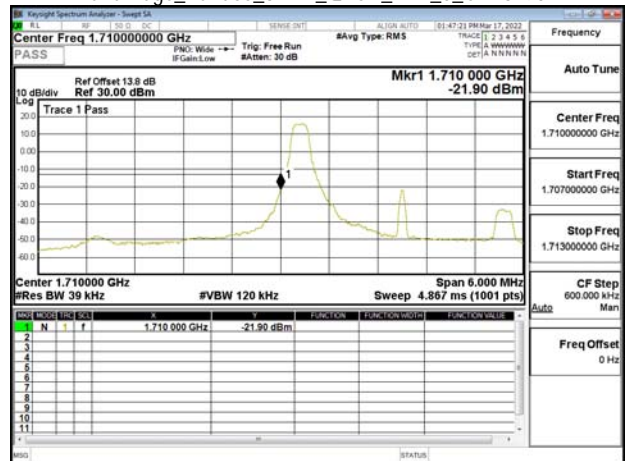

Unless otherwise stated the results shown in this test report refer only to the sample(s) tested and such sample(s) are retained for 90 days only.

除非另有說明，此報告結果僅對測試之樣品負責，同時此樣品僅保留90天。本報告未經本公司書面許可，不可部份複製。

This document is issued by the Company subject to its General Conditions of Service printed overleaf, available on request or accessible at <http://www.sgs.com.tw/Terms-and-Conditions> and for electronic format documents, subject to Terms and Conditions for Electronic Documents at <http://www.sgs.com.tw/Terms-and-Conditions>. Attention is drawn to the limitation of liability, indemnification and jurisdiction issues defined therein. Any holder of this document is advised that information contained herein reflects the Company's findings at the time of its intervention only and within the limits of Client's instructions, if any. The Company's sole responsibility is to its Client and this document does not exonerate parties to a transaction from exercising all their rights and obligations under the transaction documents. This document cannot be reproduced except in full, without prior written approval of the Company. Any unauthorized alteration, forgery or falsification of the content or appearance of this document is unlawful and offenders may be prosecuted to the fullest extent of the law.

Band Edge_Band66_3MHz_OPSK_RB1_14_CH132657

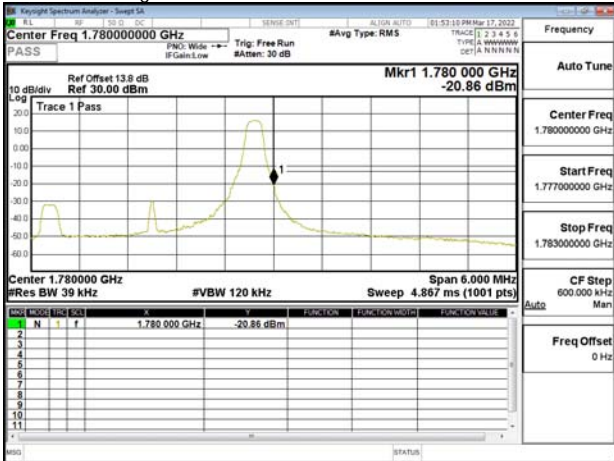

Band Edge_Band66_5MHz_OPSK_RB1_0_CH131997

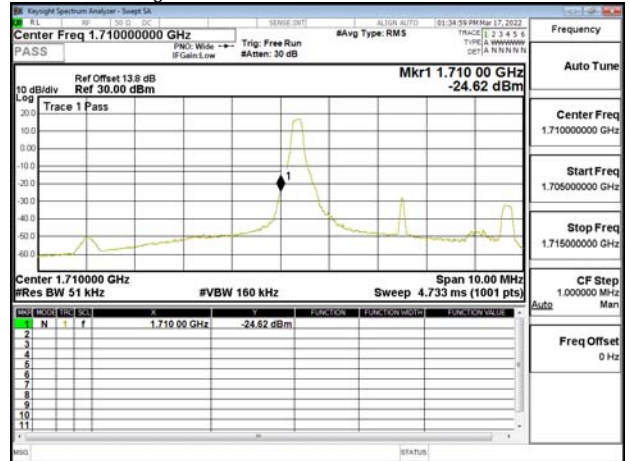

Band Edge_Band66_3MHz_OPSK_RB15_0_CH131987

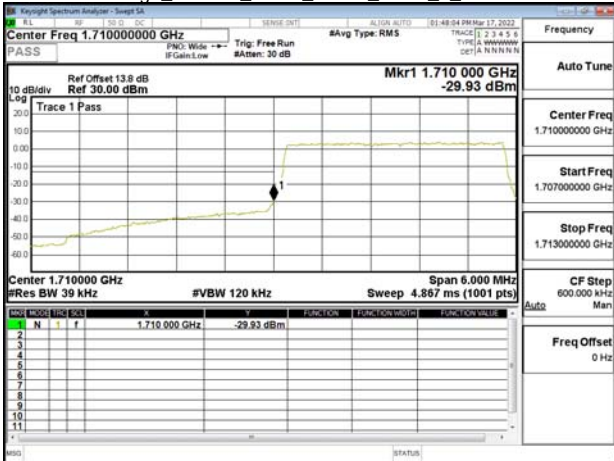

Band Edge_Band66_5MHz_OPSK_RB1_24_CH132647

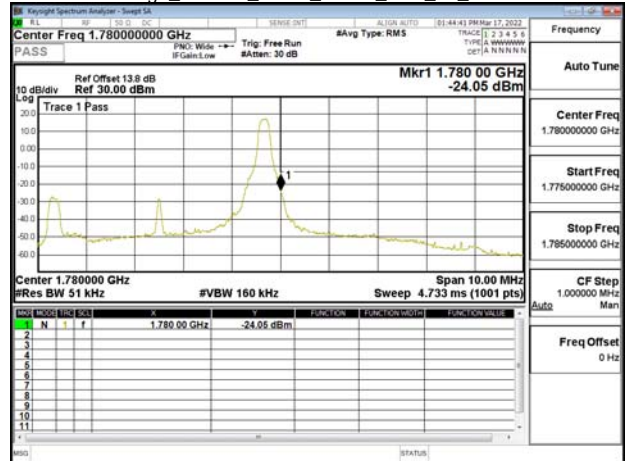

Band Edge_Band66_3MHz_OPSK_RB15_0_CH132657

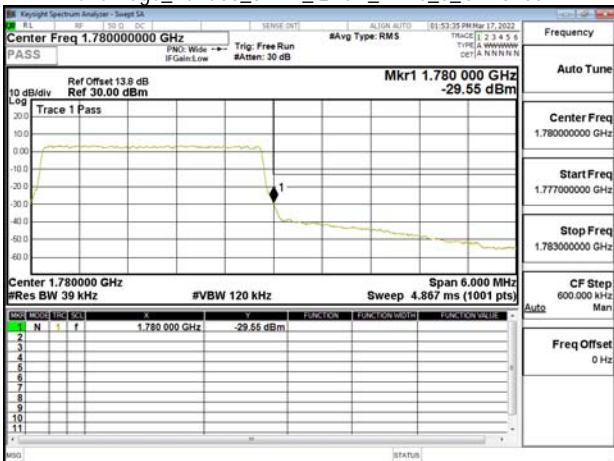

Band Edge_Band66_5MHz_OPSK_RB25_0_CH131997

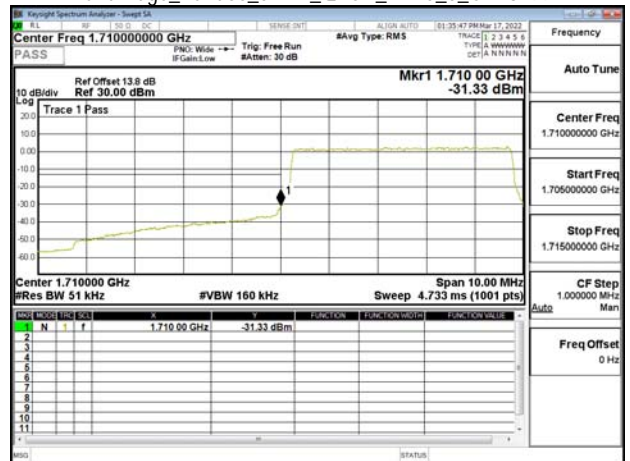

Unless otherwise stated the results shown in this test report refer only to the sample(s) tested and such sample(s) are retained for 90 days only.

除非另有說明，此報告結果僅對測試之樣品負責，同時此樣品僅保留90天。本報告未經本公司書面許可，不可部份複製。

This document is issued by the Company subject to its General Conditions of Service printed overleaf, available on request or accessible at <http://www.sgs.com.tw/Terms-and-Conditions> and for electronic format documents, subject to Terms and Conditions for Electronic Documents at <http://www.sgs.com.tw/Terms-and-Conditions>. Attention is drawn to the limitation of liability, indemnification and jurisdiction issues defined therein. Any holder of this document is advised that information contained herein reflects the Company's findings at the time of its intervention only and within the limits of Client's instructions, if any. The Company's sole responsibility is to its Client and this document does not exonerate parties to a transaction from exercising all their rights and obligations under the transaction documents. This document cannot be reproduced except in full, without prior written approval of the Company. Any unauthorized alteration, forgery or falsification of the content or appearance of this document is unlawful and offenders may be prosecuted to the fullest extent of the law.

Band Edge_Band66_5MHz_OPSK_RB25_0_CH132647

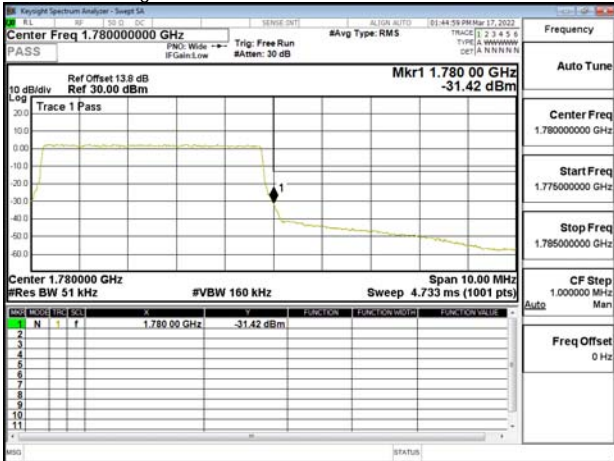

Band Edge_Band66_10MHz_OPSK_RB50_0_CH132022

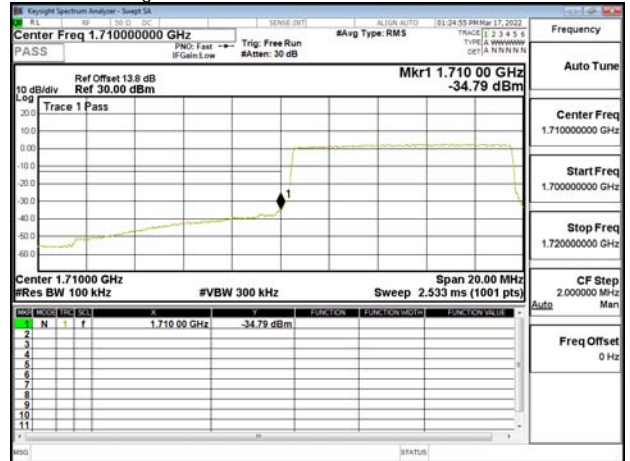

Band Edge_Band66_10MHz_OPSK_RB1_0_CH132022

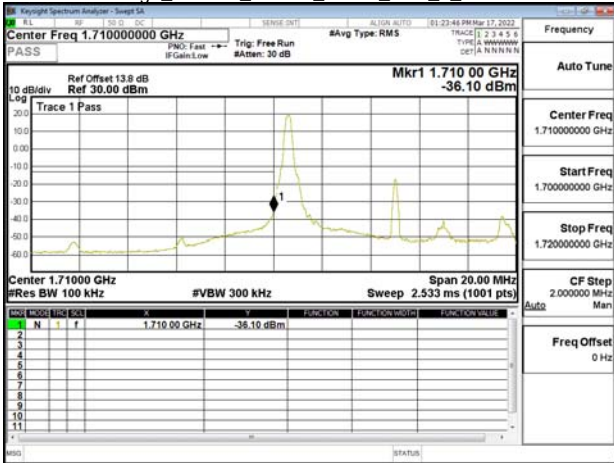

Band Edge_Band66_10MHz_OPSK_RB50_0_CH132622

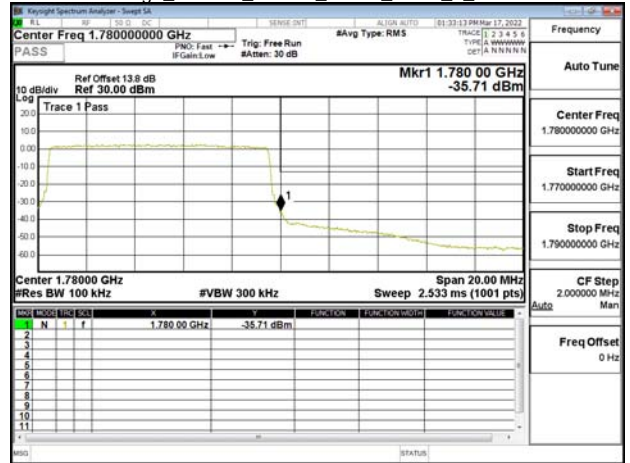

Band Edge_Band66_10MHz_OPSK_RB1_49_CH132622

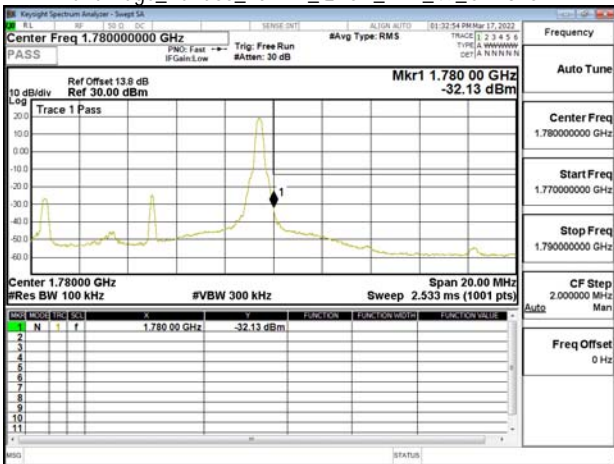

Band Edge_Band66_15MHz_OPSK_RB1_0_CH132047

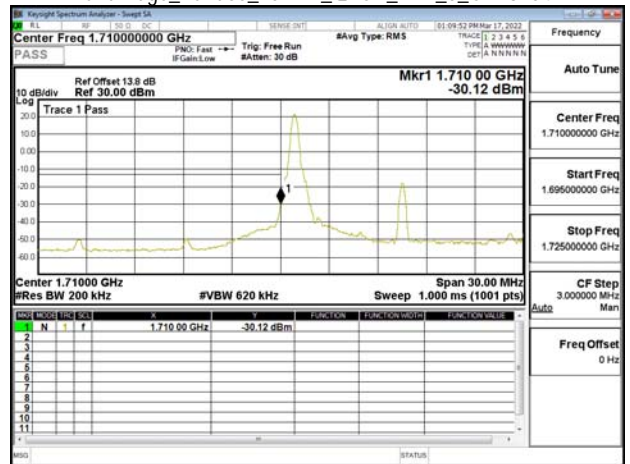

Unless otherwise stated the results shown in this test report refer only to the sample(s) tested and such sample(s) are retained for 90 days only.

除非另有說明，此報告結果僅對測試之樣品負責，同時此樣品僅保留90天。本報告未經本公司書面許可，不可部份複製。

This document is issued by the Company subject to its General Conditions of Service printed overleaf, available on request or accessible at <http://www.sgs.com.tw/Terms-and-Conditions> and for electronic format documents, subject to Terms and Conditions for Electronic Documents at <http://www.sgs.com.tw/Terms-and-Conditions>. Attention is drawn to the limitation of liability, indemnification and jurisdiction issues defined therein. Any holder of this document is advised that information contained herein reflects the Company's findings at the time of its intervention only and within the limits of Client's instructions, if any. The Company's sole responsibility is to its Client and this document does not exonerate parties to a transaction from exercising all their rights and obligations under the transaction documents. This document cannot be reproduced except in full, without prior written approval of the Company. Any unauthorized alteration, forgery or falsification of the content or appearance of this document is unlawful and offenders may be prosecuted to the fullest extent of the law.

Band Edge_Band66_15MHz_QPSK_RB1_74_CH132597

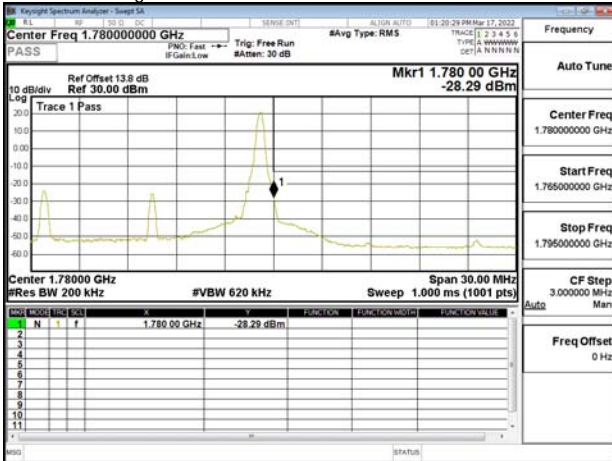

Band Edge_Band66_20MHz_QPSK_RB1_0_CH132072

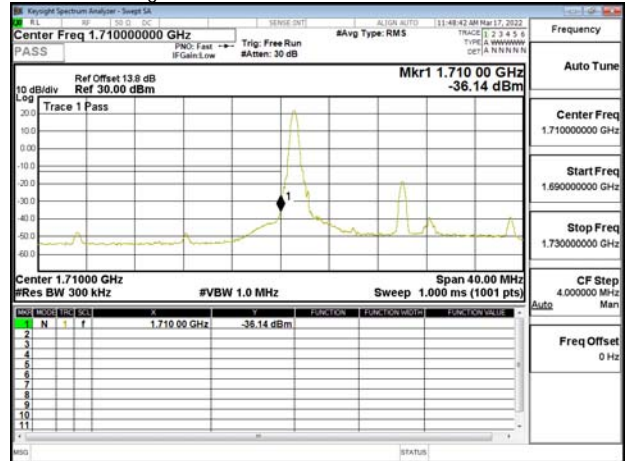

Band Edge_Band66_15MHz_QPSK_RB75_0_CH132047

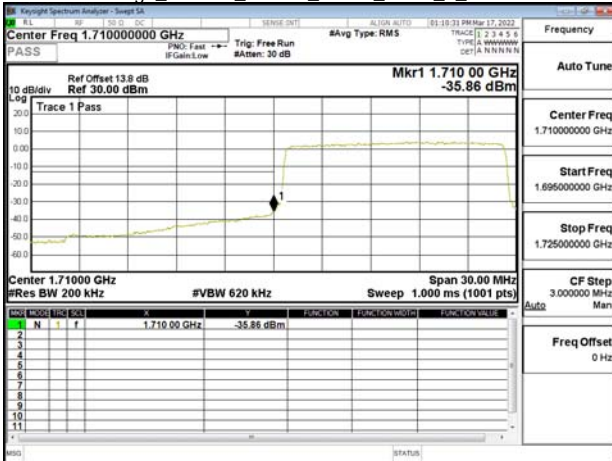

Band Edge_Band66_20MHz_QPSK_RB1_99_CH132572

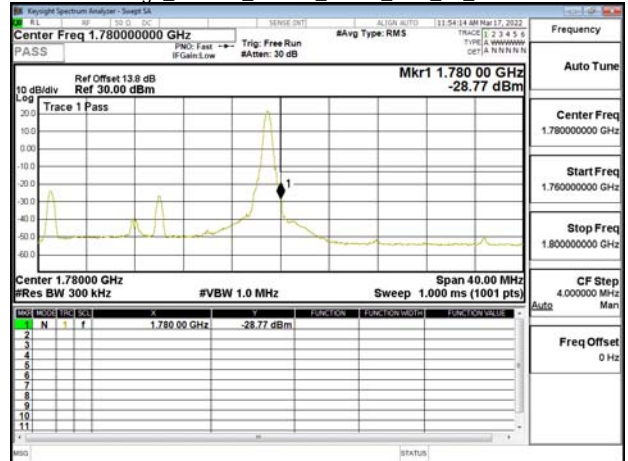

Band Edge_Band66_15MHz_QPSK_RB75_0_CH132597

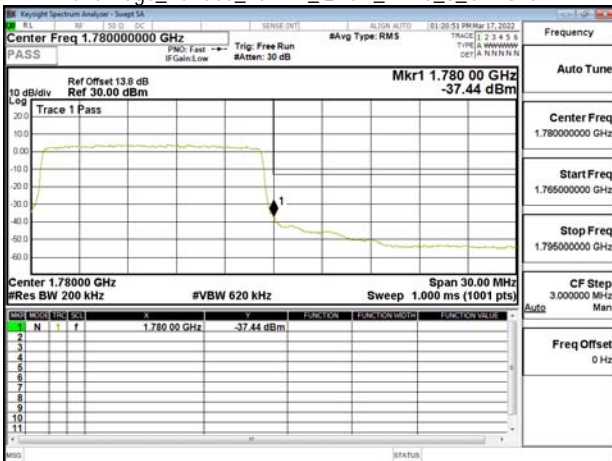

Band Edge_Band66_20MHz_QPSK_RB100_0_CH132072

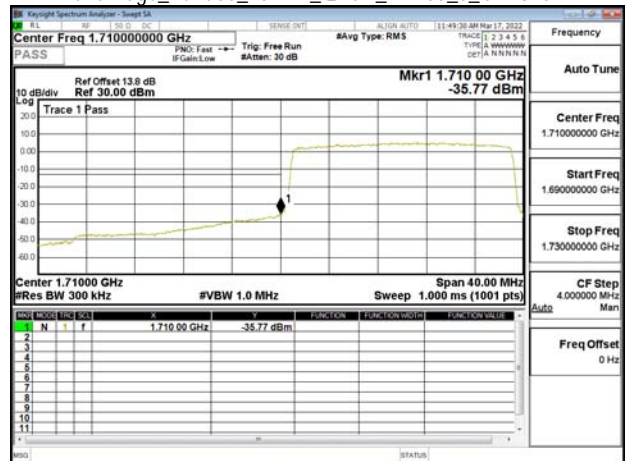

Unless otherwise stated the results shown in this test report refer only to the sample(s) tested and such sample(s) are retained for 90 days only.

除非另有說明，此報告結果僅對測試之樣品負責，同時此樣品僅保留90天。本報告未經本公司書面許可，不可部份複製。

This document is issued by the Company subject to its General Conditions of Service printed overleaf, available on request or accessible at <http://www.sgs.com.tw/Terms-and-Conditions> and for electronic format documents, subject to Terms and Conditions for Electronic Documents at <http://www.sgs.com.tw/Terms-and-Conditions>. Attention is drawn to the limitation of liability, indemnification and jurisdiction issues defined therein. Any holder of this document is advised that information contained herein reflects the Company's findings at the time of its intervention only and within the limits of Client's instructions, if any. The Company's sole responsibility is to its Client and this document does not exonerate parties to a transaction from exercising all their rights and obligations under the transaction documents. This document cannot be reproduced except in full, without prior written approval of the Company. Any unauthorized alteration, forgery or falsification of the content or appearance of this document is unlawful and offenders may be prosecuted to the fullest extent of the law.

Band Edge_Band66_20MHz_OPSK_RB100_0_CH132572

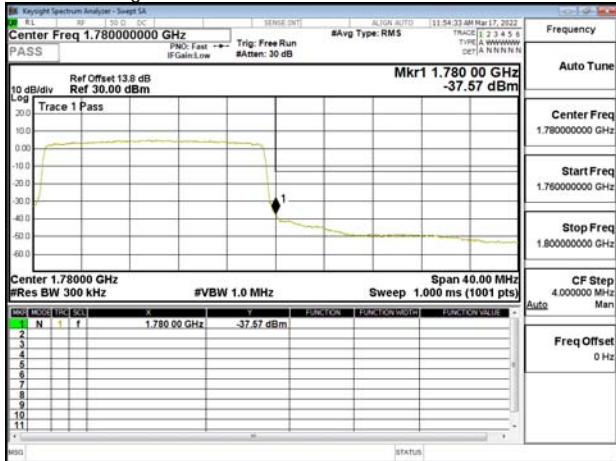

Unless otherwise stated the results shown in this test report refer only to the sample(s) tested and such sample(s) are retained for 90 days only.

除非另有說明，此報告結果僅對測試之樣品負責，同時此樣品僅保留90天。本報告未經本公司書面許可，不可部份複製。

This document is issued by the Company subject to its General Conditions of Service printed overleaf, available on request or accessible at <http://www.sgs.com.tw/Terms-and-Conditions> and for electronic format documents, subject to Terms and Conditions for Electronic Documents at <http://www.sgs.com.tw/Terms-and-Conditions>. Attention is drawn to the limitation of liability, indemnification and jurisdiction issues defined therein. Any holder of this document is advised that information contained hereon reflects the Company's findings at the time of its intervention only and within the limits of Client's instructions, if any. The Company's sole responsibility is to its Client and this document does not exonerate parties to a transaction from exercising all their rights and obligations under the transaction documents. This document cannot be reproduced except in full, without prior written approval of the Company. Any unauthorized alteration, forgery or falsification of the content or appearance of this document is unlawful and offenders may be prosecuted to the fullest extent of the law.

9.5 Spurious Emission Measurement Result:

Refer to next pages.

Unless otherwise stated the results shown in this test report refer only to the sample(s) tested and such sample(s) are retained for 90 days only.

除非另有說明，此報告結果僅對測試之樣品負責，同時此樣品僅保留90天。本報告未經本公司書面許可，不可部份複製。

This document is issued by the Company subject to its General Conditions of Service printed overleaf, available on request or accessible at <http://www.sgs.com.tw/Terms-and-Conditions> and for electronic format documents, subject to Terms and Conditions for Electronic Documents at <http://www.sgs.com.tw/Terms-and-Conditions>. Attention is drawn to the limitation of liability, indemnification and jurisdiction issues defined therein. Any holder of this document is advised that information contained hereon reflects the Company's findings at the time of its intervention only and within the limits of Client's instructions, if any. The Company's sole responsibility is to its Client and this document does not exonerate parties to a transaction from exercising all their rights and obligations under the transaction documents. This document cannot be reproduced except in full, without prior written approval of the Company. Any unauthorized alteration, forgery or falsification of the content or appearance of this document is unlawful and offenders may be prosecuted to the fullest extent of the law.

Band2_1.4MHz_QPSK_RB1_0_CH18607

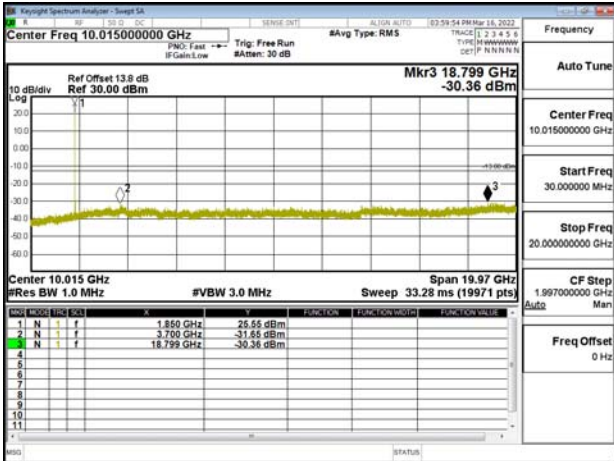

Band2_3MHz_QPSK_RB1_0_CH18615

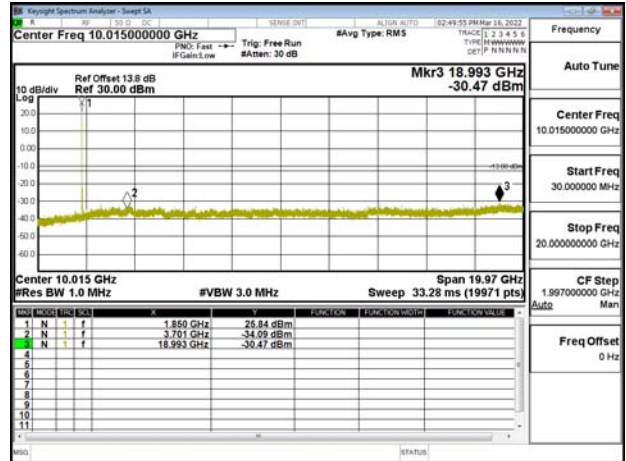

Band2_1.4MHz_QPSK_RB1_0_CH18900

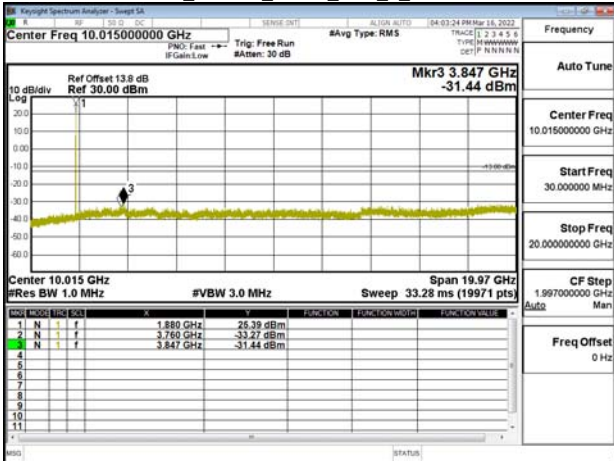

Band2_3MHz_QPSK_RB1_0_CH18900

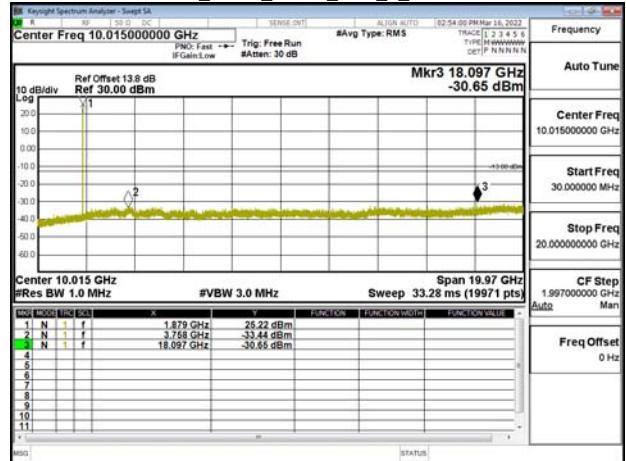

Band2_1.4MHz_QPSK_RB1_0_CH19193

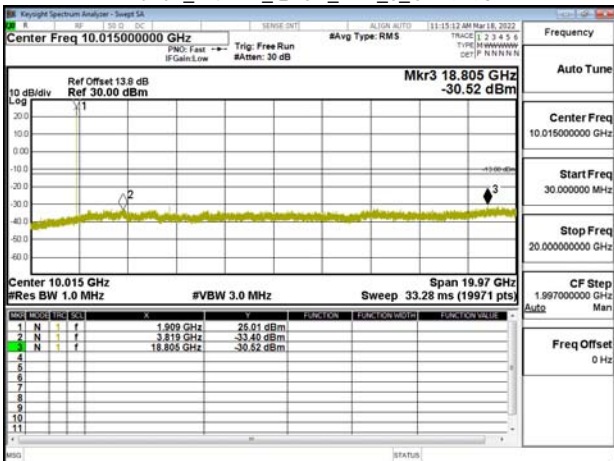

Band2_3MHz_QPSK_RB1_0_CH19185

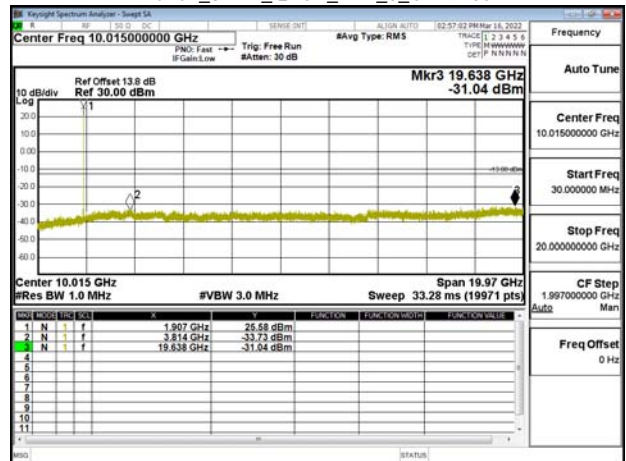

Unless otherwise stated the results shown in this test report refer only to the sample(s) tested and such sample(s) are retained for 90 days only.

除非另有說明，此報告結果僅對測試之樣品負責，同時此樣品僅保留90天。本報告未經本公司書面許可，不可部份複製。

This document is issued by the Company subject to its General Conditions of Service printed overleaf, available on request or accessible at <http://www.sgs.com.tw/Terms-and-Conditions> and for electronic format documents, subject to Terms and Conditions for Electronic Documents at <http://www.sgs.com.tw/Terms-and-Conditions>. Attention is drawn to the limitation of liability, indemnification and jurisdiction issues defined therein. Any holder of this document is advised that information contained herein reflects the Company's findings at the time of its intervention only and within the limits of Client's instructions, if any. The Company's sole responsibility is to its Client and this document does not exonerate parties to a transaction from exercising all their rights and obligations under the transaction documents. This document cannot be reproduced except in full, without prior written approval of the Company. Any unauthorized alteration, forgery or falsification of the content or appearance of this document is unlawful and offenders may be prosecuted to the fullest extent of the law.

Band2_5MHz_OPSK_RB1_0_CH18625

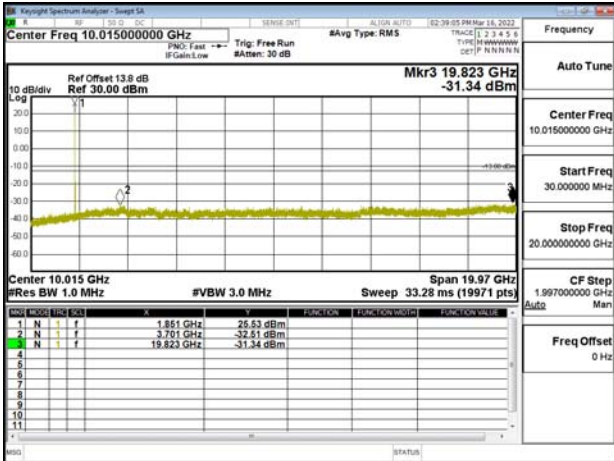

Band2_10MHz_OPSK_RB1_0_CH18650

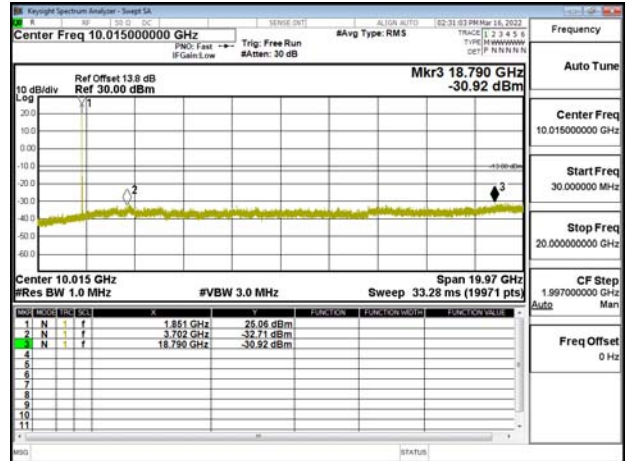

Band2_5MHz_OPSK_RB1_0_CH18900

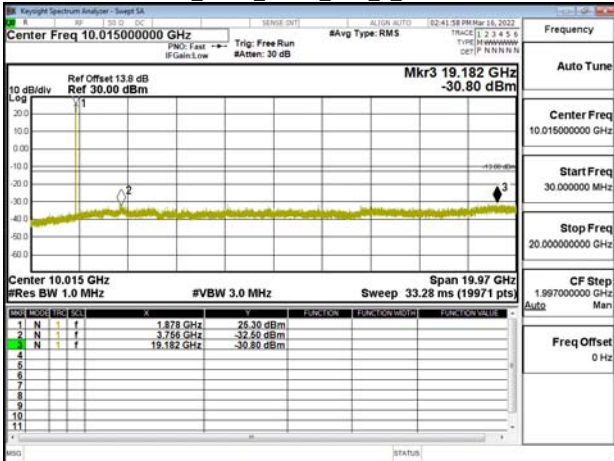

Band2_10MHz_OPSK_RB1_0_CH18900

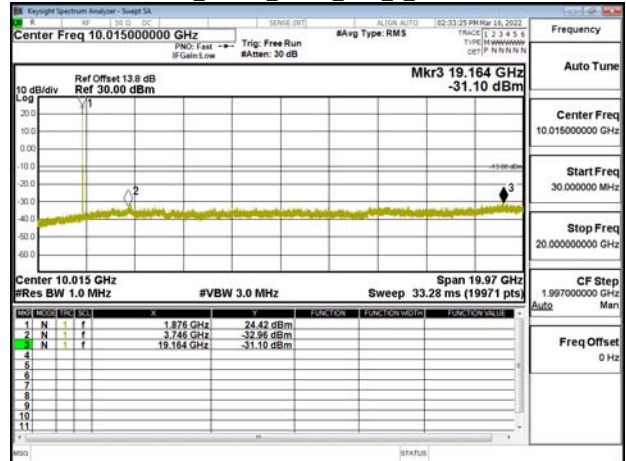

Band2_5MHz_OPSK_RB1_0_CH19175

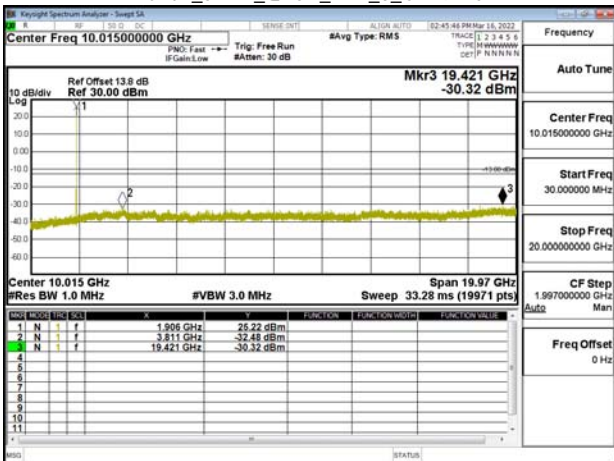

Band2_10MHz_OPSK_RB1_0_CH19150

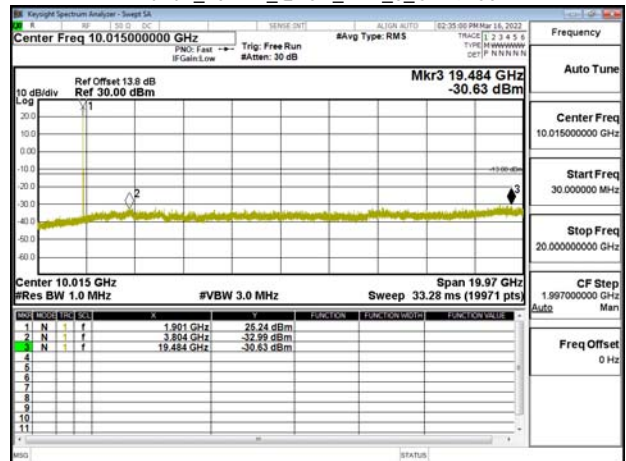

Unless otherwise stated the results shown in this test report refer only to the sample(s) tested and such sample(s) are retained for 90 days only.

除非另有說明，此報告結果僅對測試之樣品負責，同時此樣品僅保留90天。本報告未經本公司書面許可，不可部份複製。

This document is issued by the Company subject to its General Conditions of Service printed overleaf, available on request or accessible at <http://www.sgs.com.tw/Terms-and-Conditions> and for electronic format documents, subject to Terms and Conditions for Electronic Documents at <http://www.sgs.com.tw/Terms-and-Conditions>. Attention is drawn to the limitation of liability, indemnification and jurisdiction issues defined therein. Any holder of this document is advised that information contained herein reflects the Company's findings at the time of its intervention only and within the limits of Client's instructions, if any. The Company's sole responsibility is to its Client and this document does not exonerate parties to a transaction from exercising all their rights and obligations under the transaction documents. This document cannot be reproduced except in full, without prior written approval of the Company. Any unauthorized alteration, forgery or falsification of the content or appearance of this document is unlawful and offenders may be prosecuted to the fullest extent of the law.

Band2_15MHz_QPSK_RB1_0_CH18675

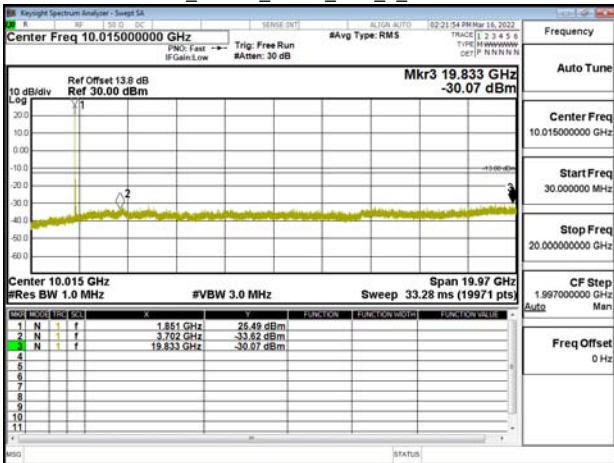

Band2_20MHz_QPSK_RB1_0_CH18700

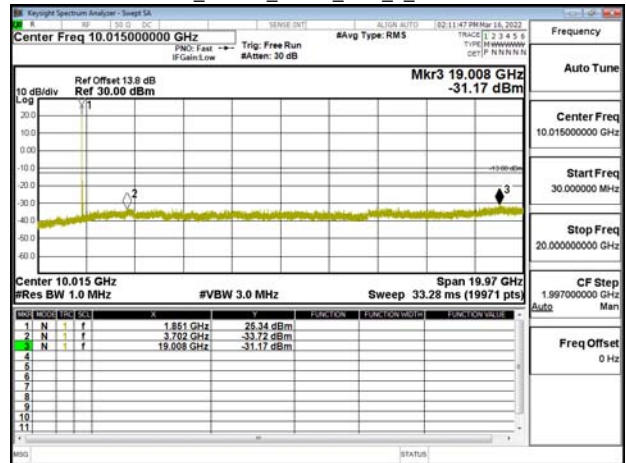

Band2_15MHz_QPSK_RB1_0_CH18900

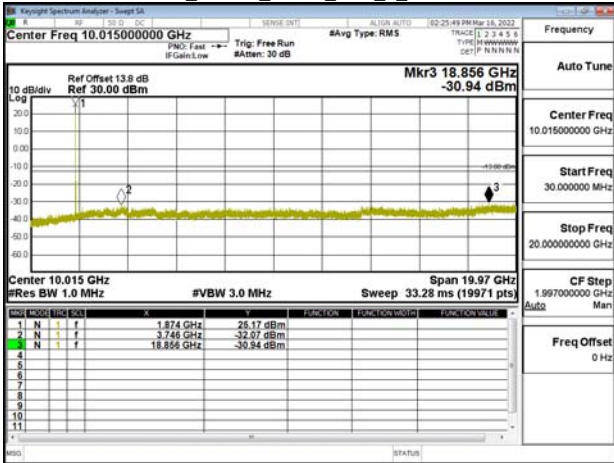

Band2_20MHz_QPSK_RB1_0_CH18900

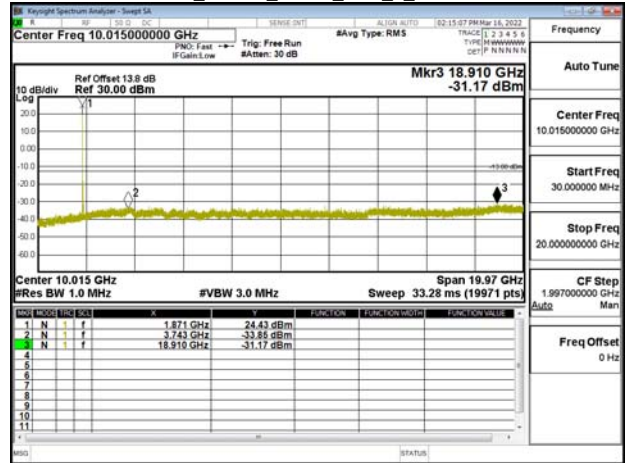

Band2_15MHz_QPSK_RB1_0_CH19125

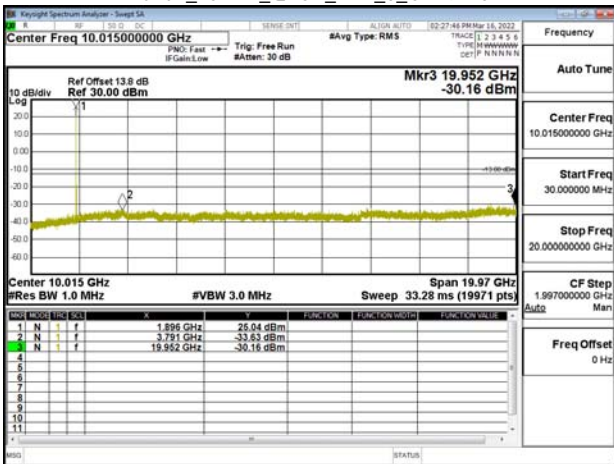

Band2_20MHz_QPSK_RB1_0_CH19100

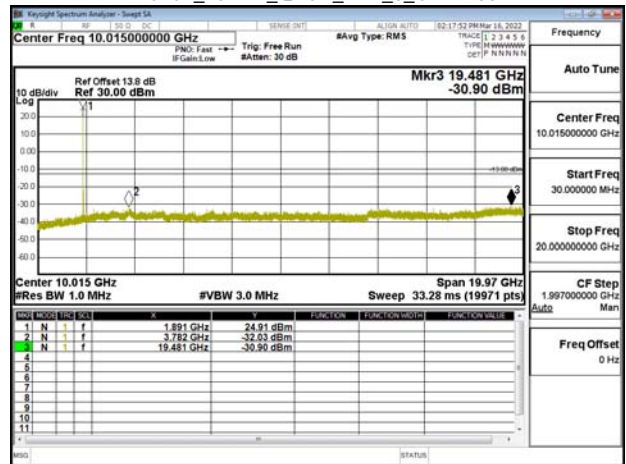

Unless otherwise stated the results shown in this test report refer only to the sample(s) tested and such sample(s) are retained for 90 days only.

除非另有說明，此報告結果僅對測試之樣品負責，同時此樣品僅保留90天。本報告未經本公司書面許可，不可部份複製。

This document is issued by the Company subject to its General Conditions of Service printed overleaf, available on request or accessible at <http://www.sgs.com.tw/Terms-and-Conditions> and for electronic format documents, subject to Terms and Conditions for Electronic Documents at <http://www.sgs.com.tw/Terms-and-Conditions>. Attention is drawn to the limitation of liability, indemnification and jurisdiction issues defined therein. Any holder of this document is advised that information contained herein reflects the Company's findings at the time of its intervention only and within the limits of Client's instructions, if any. The Company's sole responsibility is to its Client and this document does not exonerate parties to a transaction from exercising all their rights and obligations under the transaction documents. This document cannot be reproduced except in full, without prior written approval of the Company. Any unauthorized alteration, forgery or falsification of the content or appearance of this document is unlawful and offenders may be prosecuted to the fullest extent of the law.

Band4_1.4MHz_QPSK_RB1_0_CH19957

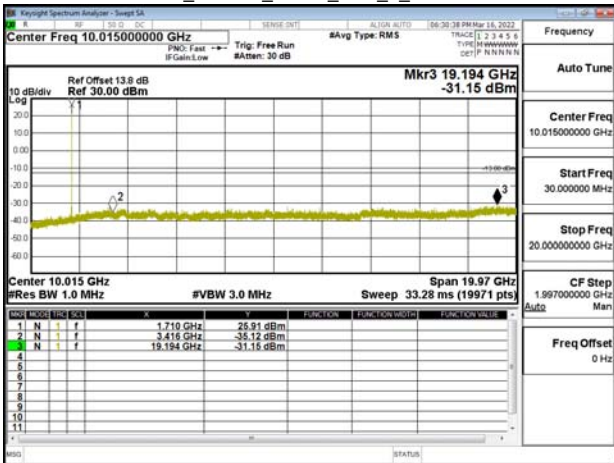

Band4_3MHz_QPSK_RB1_0_CH19965

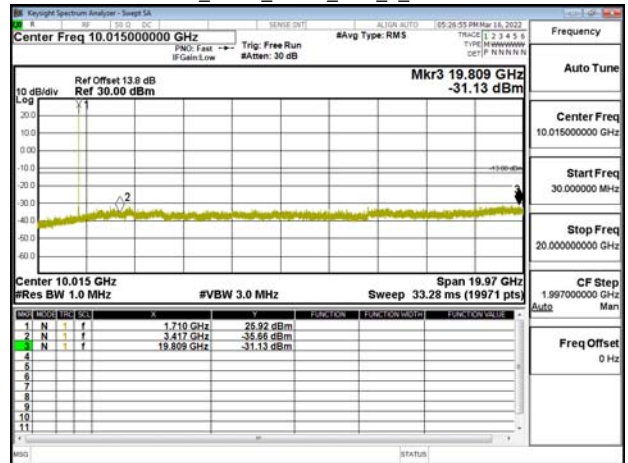

Band4_1.4MHz_QPSK_RB1_0_CH20175

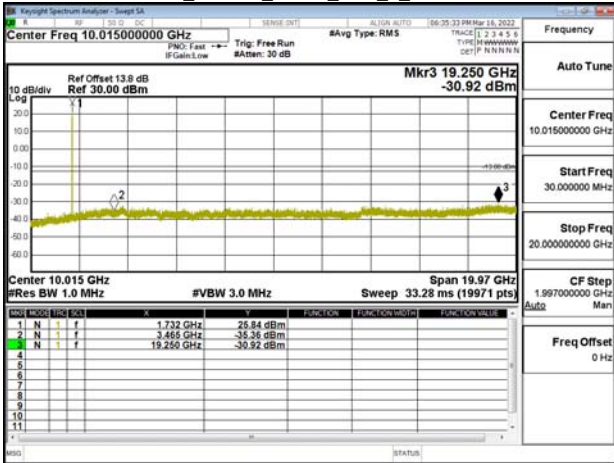

Band4_3MHz_QPSK_RB1_0_CH20175

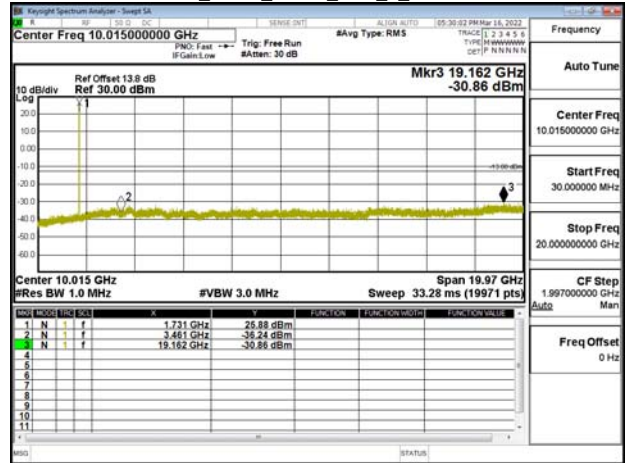

Band4_1.4MHz_QPSK_RB1_0_CH20393

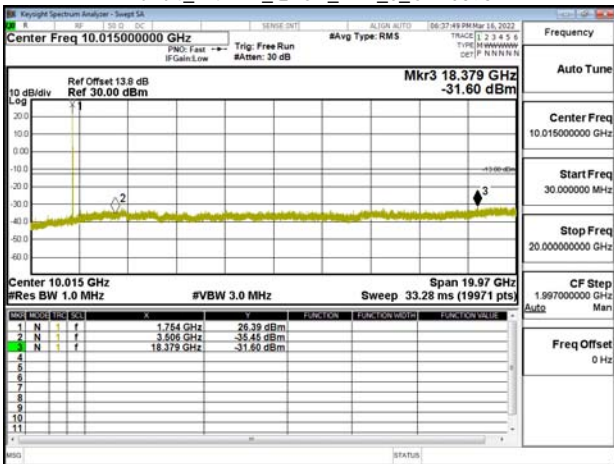

Band4_3MHz_QPSK_RB1_0_CH20385

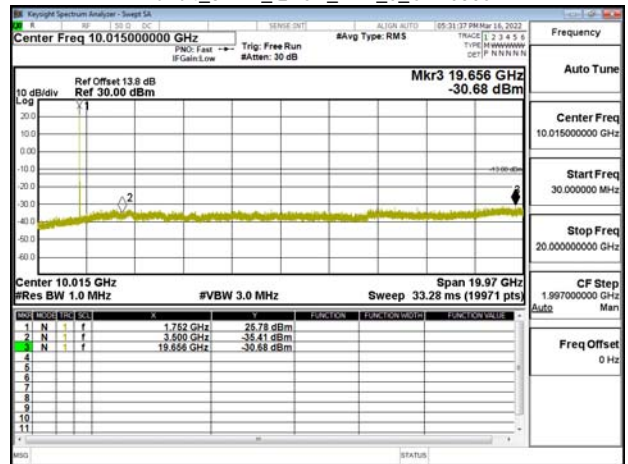

Unless otherwise stated the results shown in this test report refer only to the sample(s) tested and such sample(s) are retained for 90 days only.

除非另有說明，此報告結果僅對測試之樣品負責，同時此樣品僅保留90天。本報告未經本公司書面許可，不可部份複製。
This document is issued by the Company subject to its General Conditions of Service printed overleaf, available on request or accessible at <http://www.sgs.com.tw/Terms-and-Conditions> and for electronic format documents, subject to Terms and Conditions for Electronic Documents at <http://www.sgs.com.tw/Terms-and-Conditions>. Attention is drawn to the limitation of liability, indemnification and jurisdiction issues defined therein. Any holder of this document is advised that information contained herein reflects the Company's findings at the time of its intervention only and within the limits of Client's instructions, if any. The Company's sole responsibility is to its Client and this document does not exonerate parties to a transaction from exercising all their rights and obligations under the transaction documents. This document cannot be reproduced except in full, without prior written approval of the Company. Any unauthorized alteration, forgery or falsification of the content or appearance of this document is unlawful and offenders may be prosecuted to the fullest extent of the law.

Band4_5MHz_OPSK_RB1_0_CH19975

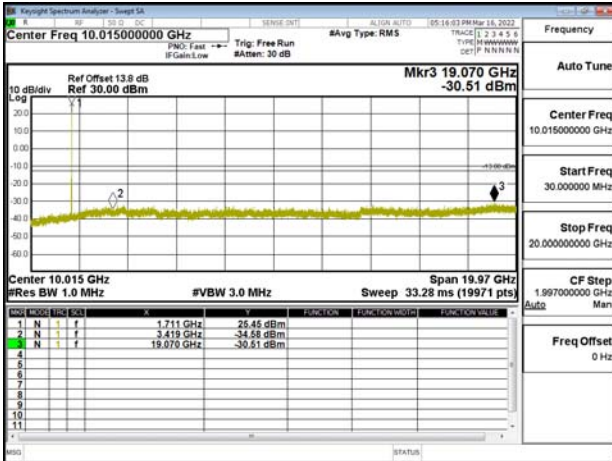

Band4_10MHz_OPSK_RB1_0_CH20000

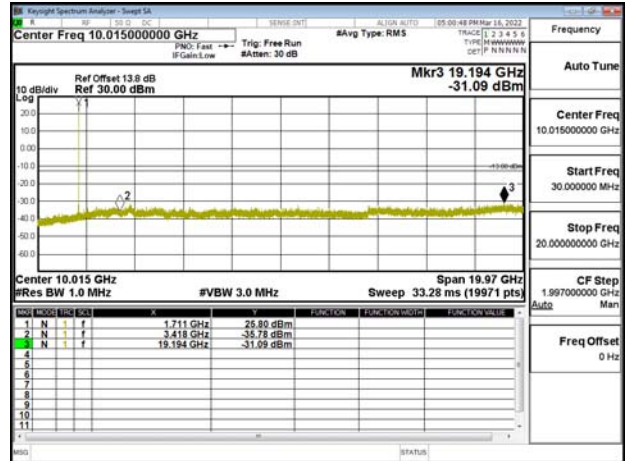

Band4_5MHz_OPSK_RB1_0_CH20175

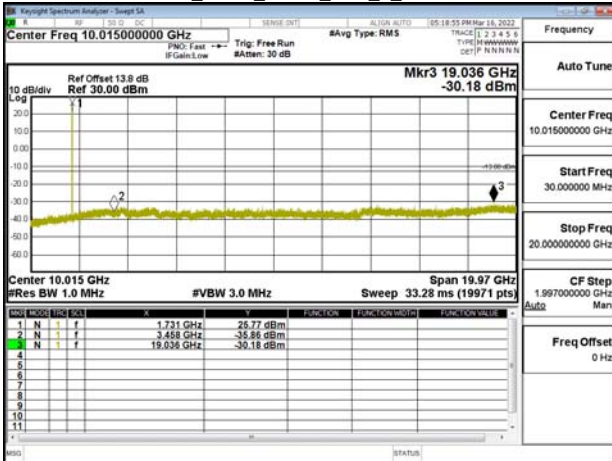

Band4_10MHz_OPSK_RB1_0_CH20175



Band4_5MHz_OPSK_RB1_0_CH20375

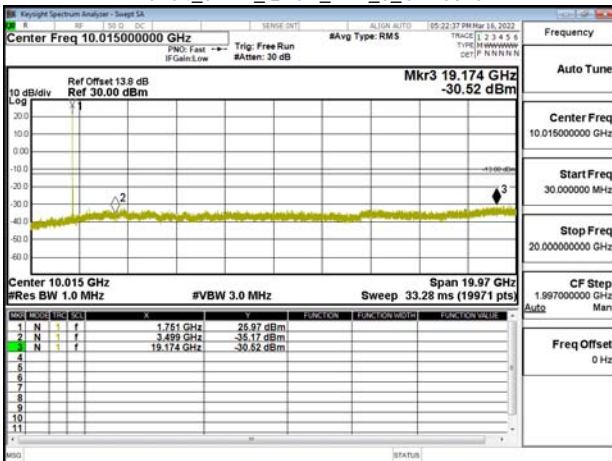

Band4_10MHz_OPSK_RB1_0_CH20350

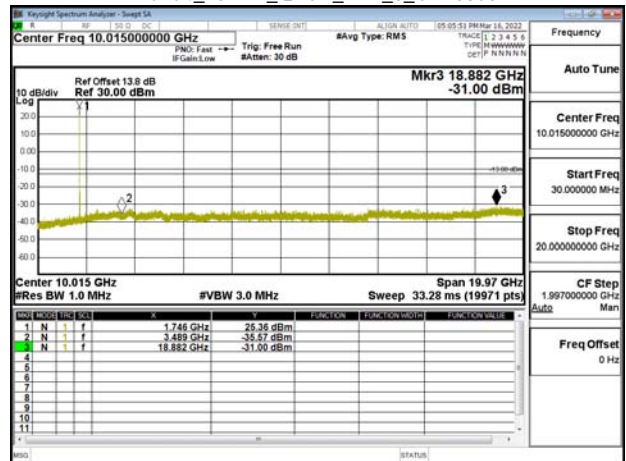

Unless otherwise stated the results shown in this test report refer only to the sample(s) tested and such sample(s) are retained for 90 days only.

除非另有說明，此報告結果僅對測試之樣品負責，同時此樣品僅保留90天。本報告未經本公司書面許可，不可部份複製。

This document is issued by the Company subject to its General Conditions of Service printed overleaf, available on request or accessible at <http://www.sgs.com.tw/Terms-and-Conditions> and for electronic format documents, subject to Terms and Conditions for Electronic Documents at <http://www.sgs.com.tw/Terms-and-Conditions>. Attention is drawn to the limitation of liability, indemnification and jurisdiction issues defined therein. Any holder of this document is advised that information contained herein reflects the Company's findings at the time of its intervention only and within the limits of Client's instructions, if any. The Company's sole responsibility is to its Client and this document does not exonerate parties to a transaction from exercising all their rights and obligations under the transaction documents. This document cannot be reproduced except in full, without prior written approval of the Company. Any unauthorized alteration, forgery or falsification of the content or appearance of this document is unlawful and offenders may be prosecuted to the fullest extent of the law.

Band4_15MHz_QPSK_RB1_0_CH20025

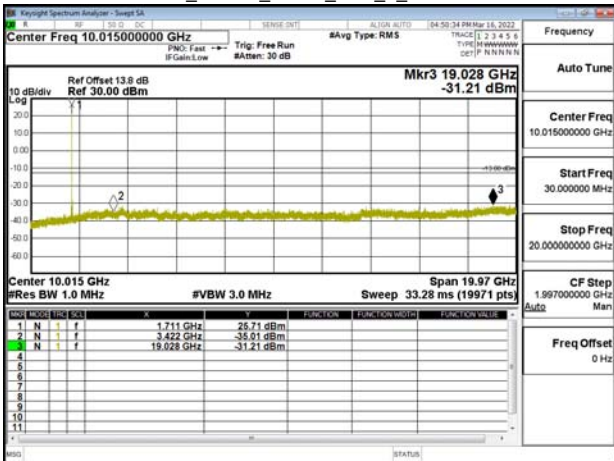

Band4_20MHz_QPSK_RB1_0_CH20050

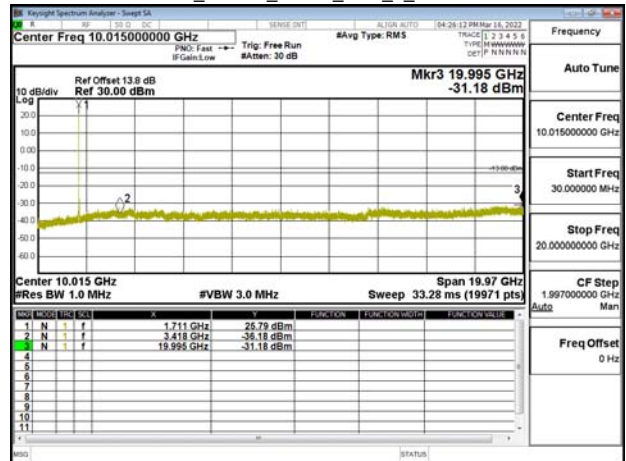

Band4_15MHz_QPSK_RB1_0_CH20175

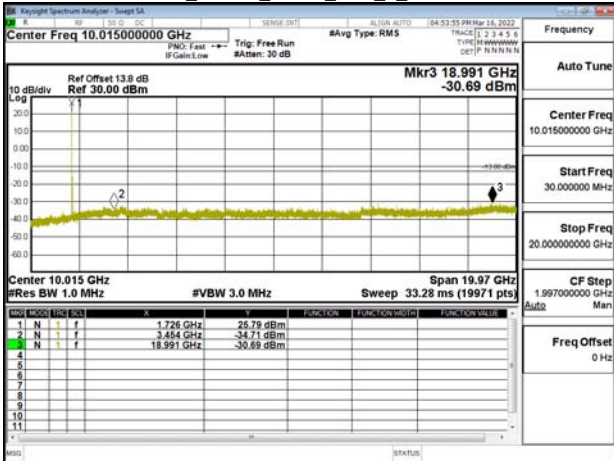

Band4_20MHz_QPSK_RB1_0_CH20175

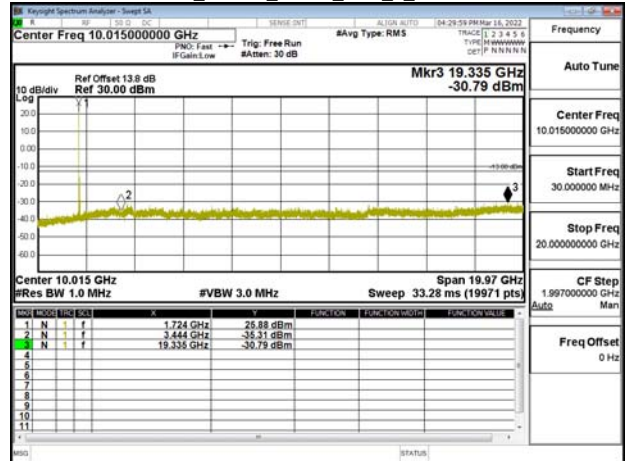

Band4_15MHz_QPSK_RB1_0_CH20325

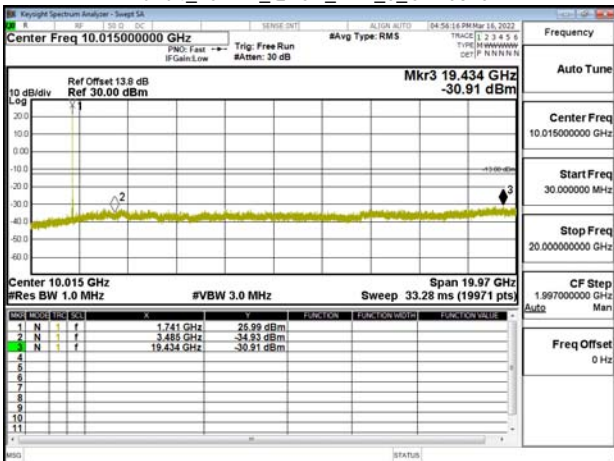

Band4_20MHz_QPSK_RB1_0_CH20300

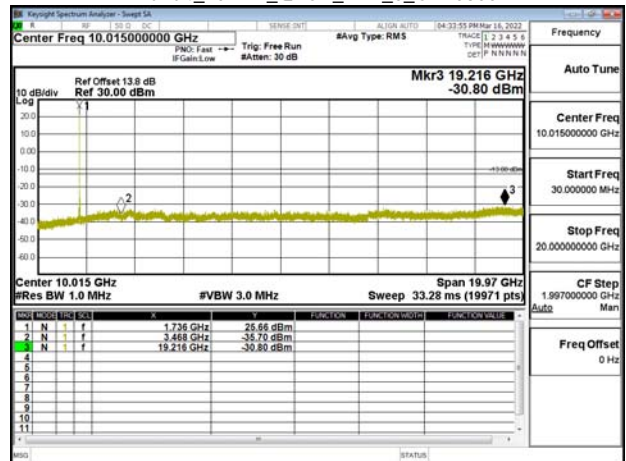

Unless otherwise stated the results shown in this test report refer only to the sample(s) tested and such sample(s) are retained for 90 days only.

除非另有說明，此報告結果僅對測試之樣品負責，同時此樣品僅保留90天。本報告未經本公司書面許可，不可部份複製。

This document is issued by the Company subject to its General Conditions of Service printed overleaf, available on request or accessible at <http://www.sgs.com.tw/Terms-and-Conditions> and for electronic format documents, subject to Terms and Conditions for Electronic Documents at <http://www.sgs.com.tw/Terms-and-Conditions>. Attention is drawn to the limitation of liability, indemnification and jurisdiction issues defined therein. Any holder of this document is advised that information contained herein reflects the Company's findings at the time of its intervention only and within the limits of Client's instructions, if any. The Company's sole responsibility is to its Client and this document does not exonerate parties to a transaction from exercising all their rights and obligations under the transaction documents. This document cannot be reproduced except in full, without prior written approval of the Company. Any unauthorized alteration, forgery or falsification of the content or appearance of this document is unlawful and offenders may be prosecuted to the fullest extent of the law.

Band5_1.4MHz_QPSK_RB1_0_CH20407

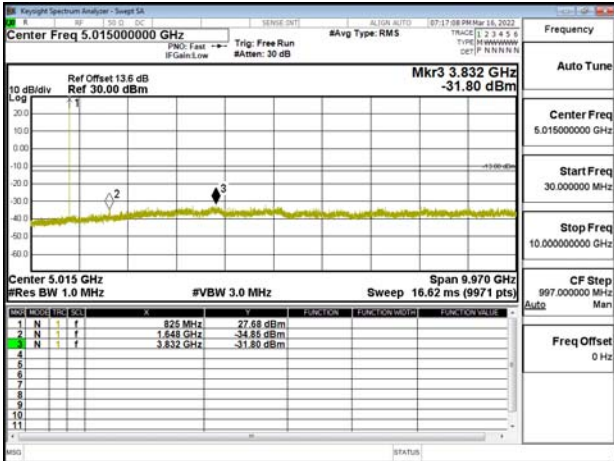

Band5_3MHz_QPSK_RB1_0_CH20415

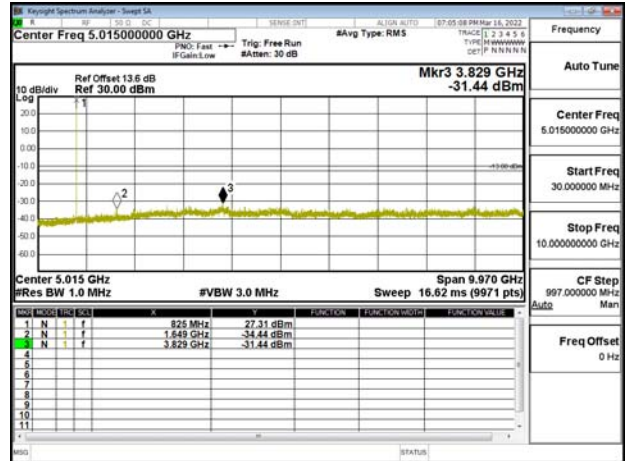

Band5_1.4MHz_QPSK_RB1_0_CH20525

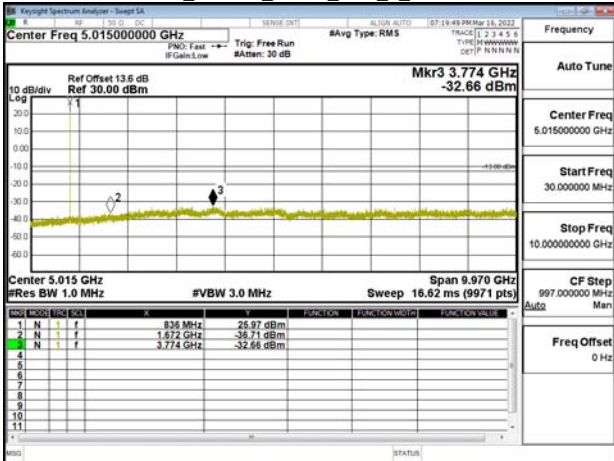

Band5_3MHz_QPSK_RB1_0_CH20525

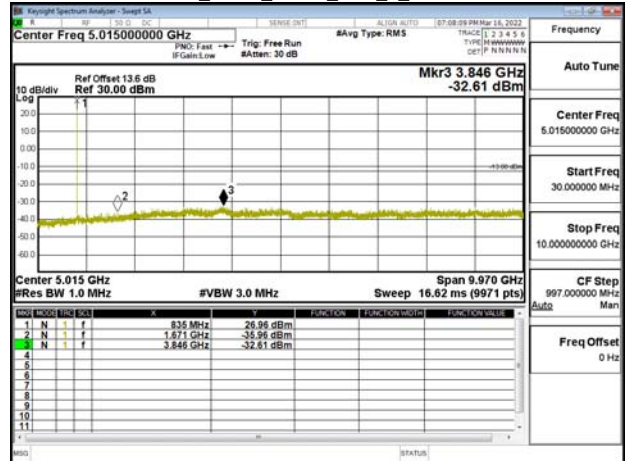

Band5_1.4MHz_QPSK_RB1_0_CH20643

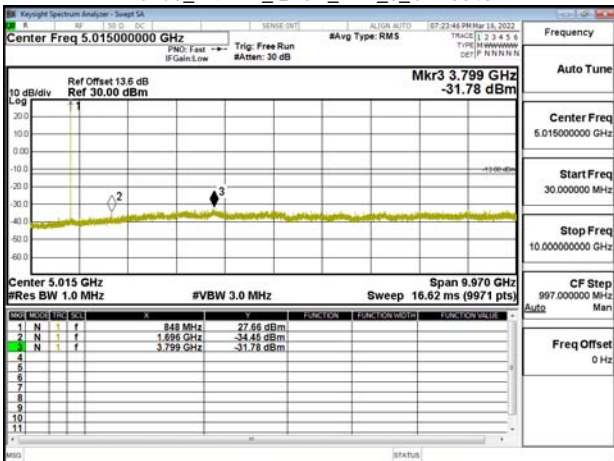

Band5_3MHz_QPSK_RB1_0_CH20635

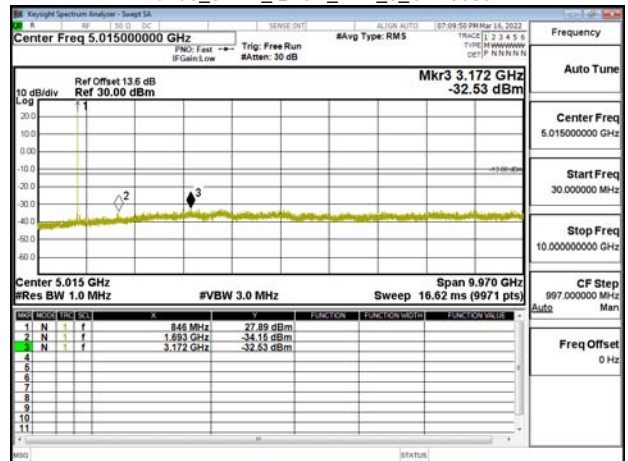

Unless otherwise stated the results shown in this test report refer only to the sample(s) tested and such sample(s) are retained for 90 days only.

除非另有說明，此報告結果僅對測試之樣品負責，同時此樣品僅保留90天。本報告未經本公司書面許可，不可部份複製。

This document is issued by the Company subject to its General Conditions of Service printed overleaf, available on request or accessible at <http://www.sgs.com.tw/Terms-and-Conditions> and for electronic format documents, subject to Terms and Conditions for Electronic Documents at <http://www.sgs.com.tw/Terms-and-Conditions>. Attention is drawn to the limitation of liability, indemnification and jurisdiction issues defined therein. Any holder of this document is advised that information contained herein reflects the Company's findings at the time of its intervention only and within the limits of Client's instructions, if any. The Company's sole responsibility is to its Client and this document does not exonerate parties to a transaction from exercising all their rights and obligations under the transaction documents. This document cannot be reproduced except in full, without prior written approval of the Company. Any unauthorized alteration, forgery or falsification of the content or appearance of this document is unlawful and offenders may be prosecuted to the fullest extent of the law.

Band5_5MHz_OPSK_RB1_0_CH20425

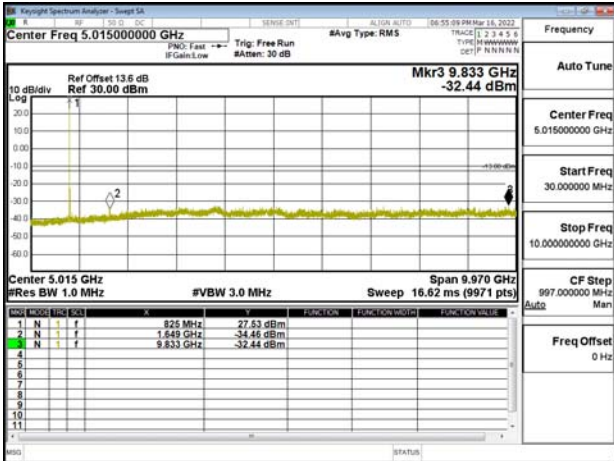

Band5_10MHz_OPSK_RB1_0_CH20450

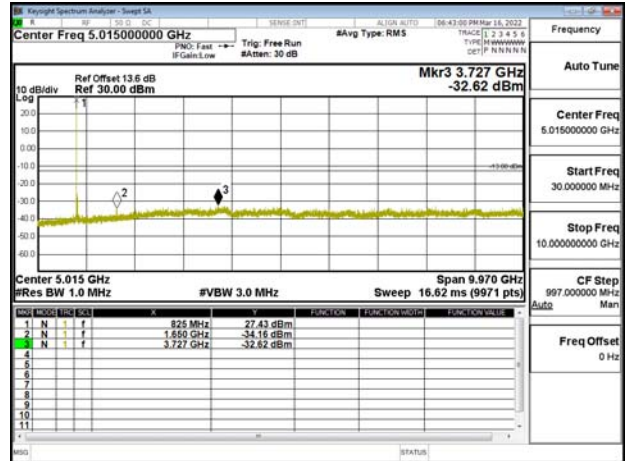

Band5_5MHz_OPSK_RB1_0_CH20525

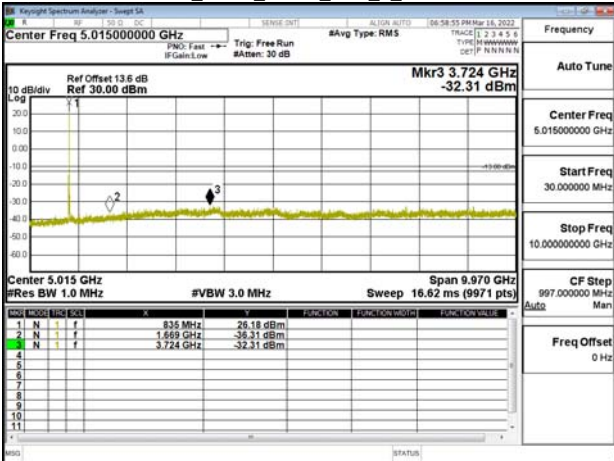

Band5_10MHz_OPSK_RB1_0_CH20525

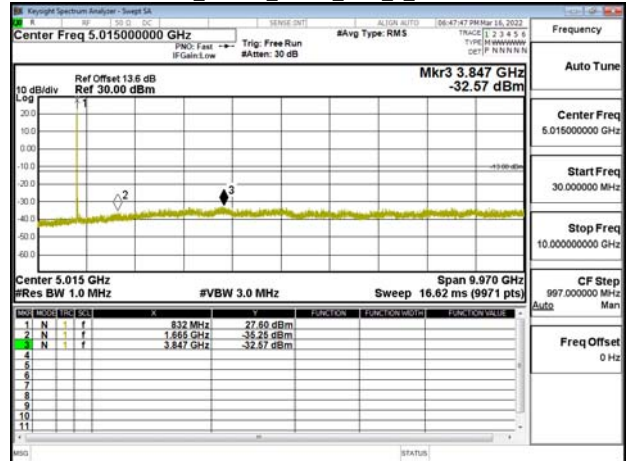

Band5_5MHz_OPSK_RB1_0_CH20625

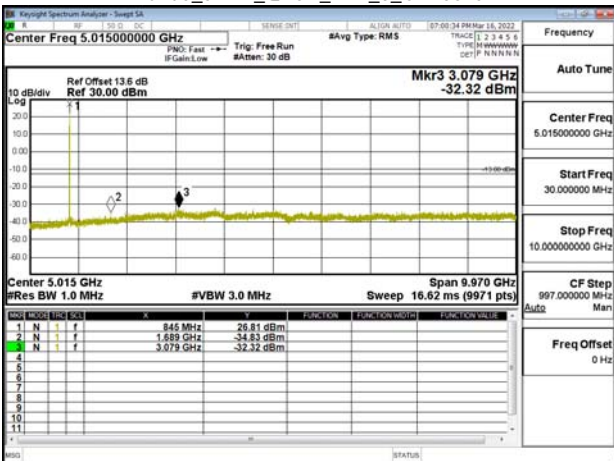

Band5_10MHz_OPSK_RB1_0_CH20600

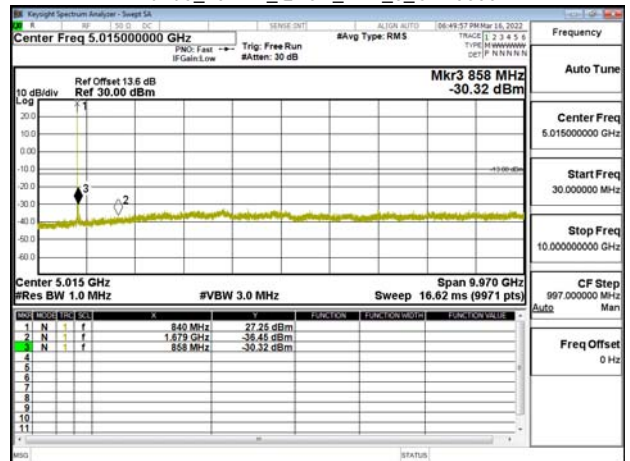

Unless otherwise stated the results shown in this test report refer only to the sample(s) tested and such sample(s) are retained for 90 days only.

除非另有說明，此報告結果僅對測試之樣品負責，同時此樣品僅保留90天。本報告未經本公司書面許可，不可部份複製。
This document is issued by the Company subject to its General Conditions of Service printed overleaf, available on request or accessible at <http://www.sgs.com.tw/Terms-and-Conditions> and for electronic format documents, subject to Terms and Conditions for Electronic Documents at <http://www.sgs.com.tw/Terms-and-Conditions>. Attention is drawn to the limitation of liability, indemnification and jurisdiction issues defined therein. Any holder of this document is advised that information contained herein reflects the Company's findings at the time of its intervention only and within the limits of Client's instructions, if any. The Company's sole responsibility is to its Client and this document does not exonerate parties to a transaction from exercising all their rights and obligations under the transaction documents. This document cannot be reproduced except in full, without prior written approval of the Company. Any unauthorized alteration, forgery or falsification of the content or appearance of this document is unlawful and offenders may be prosecuted to the fullest extent of the law.

Band12_1.4MHz_QPSK_RB1_0_CH23017

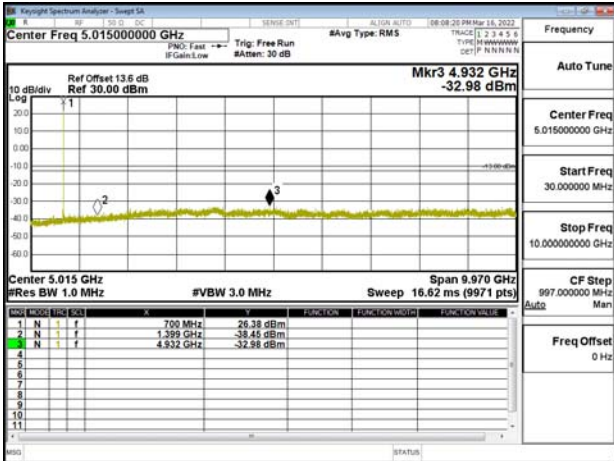

Band12_3MHz_QPSK_RB1_0_CH23025

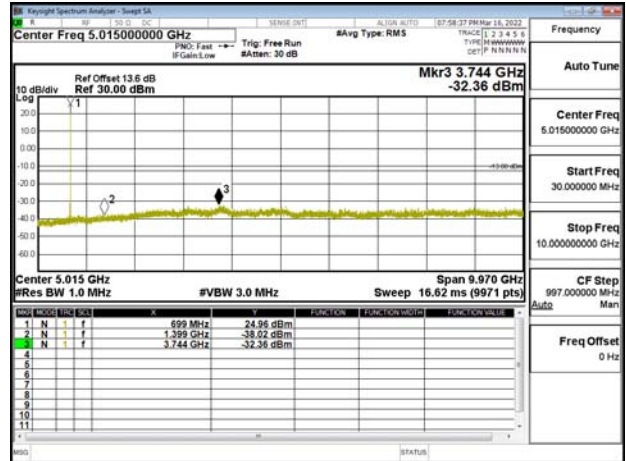

Band12_1.4MHz_QPSK_RB1_0_CH23095

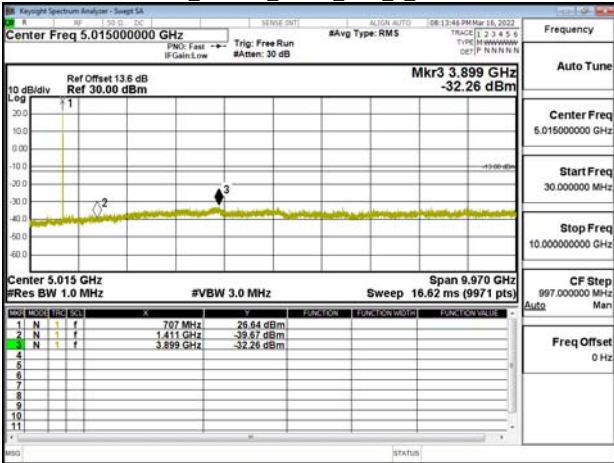

Band12_3MHz_QPSK_RB1_0_CH23095

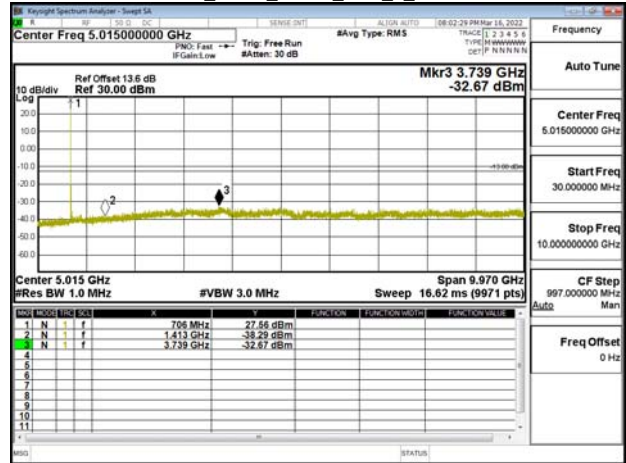

Band12_1.4MHz_QPSK_RB1_0_CH23173

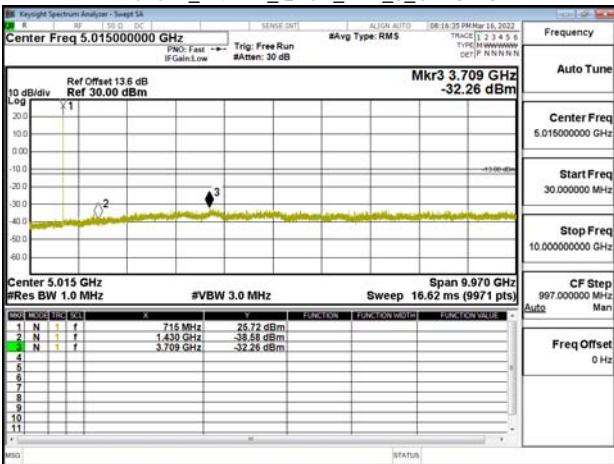

Band12_3MHz_QPSK_RB1_0_CH23165

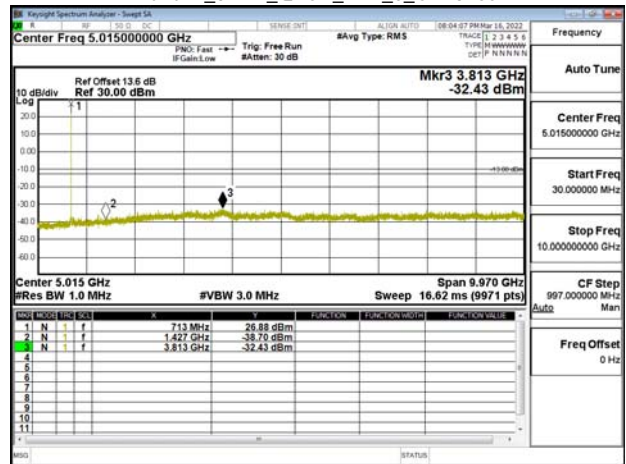

Unless otherwise stated the results shown in this test report refer only to the sample(s) tested and such sample(s) are retained for 90 days only.

除非另有說明，此報告結果僅對測試之樣品負責，同時此樣品僅保留90天。本報告未經本公司書面許可，不可部份複製。

This document is issued by the Company subject to its General Conditions of Service printed overleaf, available on request or accessible at <http://www.sgs.com.tw/Terms-and-Conditions> and for electronic format documents, subject to Terms and Conditions for Electronic Documents at <http://www.sgs.com.tw/Terms-and-Conditions>. Attention is drawn to the limitation of liability, indemnification and jurisdiction issues defined therein. Any holder of this document is advised that information contained herein reflects the Company's findings at the time of its intervention only and within the limits of Client's instructions, if any. The Company's sole responsibility is to its Client and this document does not exonerate parties to a transaction from exercising all their rights and obligations under the transaction documents. This document cannot be reproduced except in full, without prior written approval of the Company. Any unauthorized alteration, forgery or falsification of the content or appearance of this document is unlawful and offenders may be prosecuted to the fullest extent of the law.

Band12_5MHz_QPSK_RB1_0_CH23035

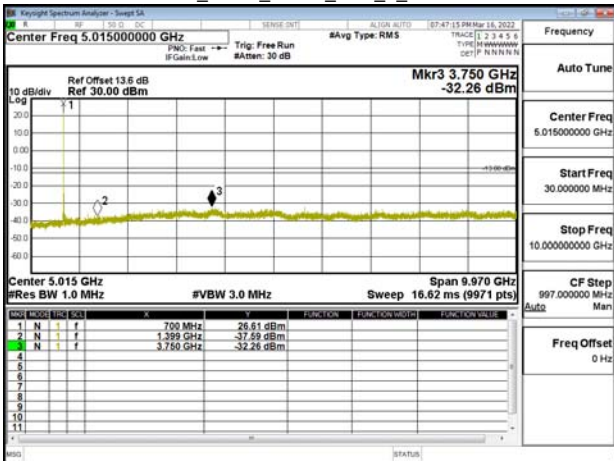

Band12_10MHz_QPSK_RB1_0_CH23060

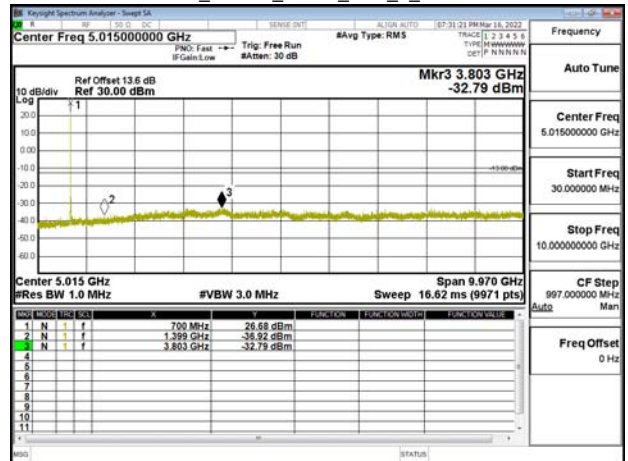

Band12_5MHz_QPSK_RB1_0_CH23095

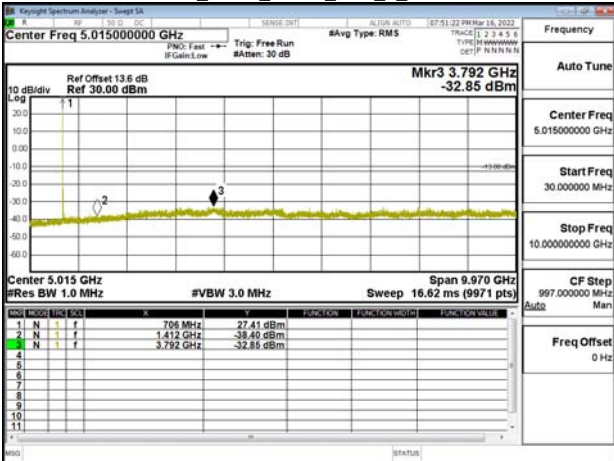

Band12_10MHz_QPSK_RB1_0_CH23095

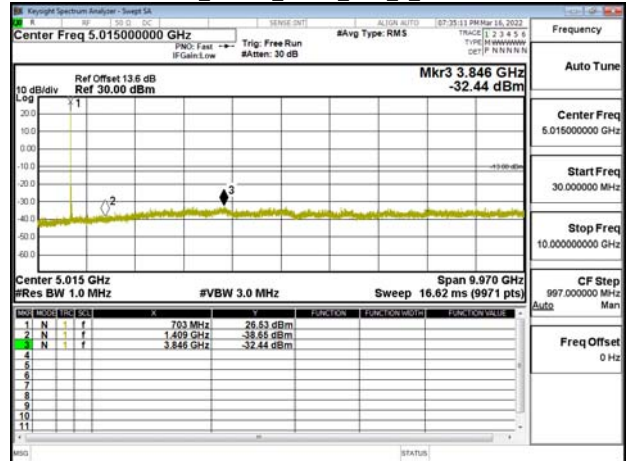

Band12_5MHz_QPSK_RB1_0_CH23155

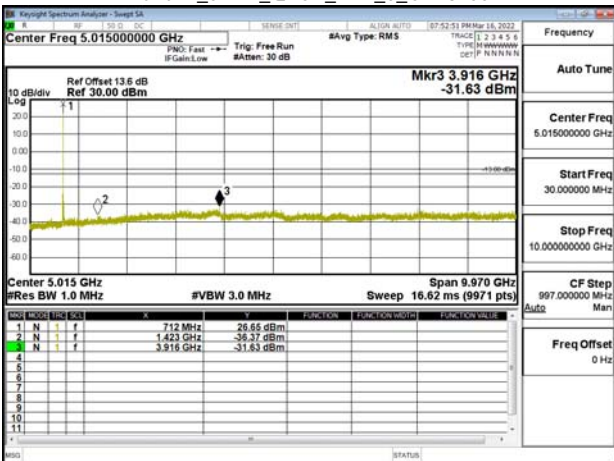

Band12_10MHz_QPSK_RB1_0_CH23130

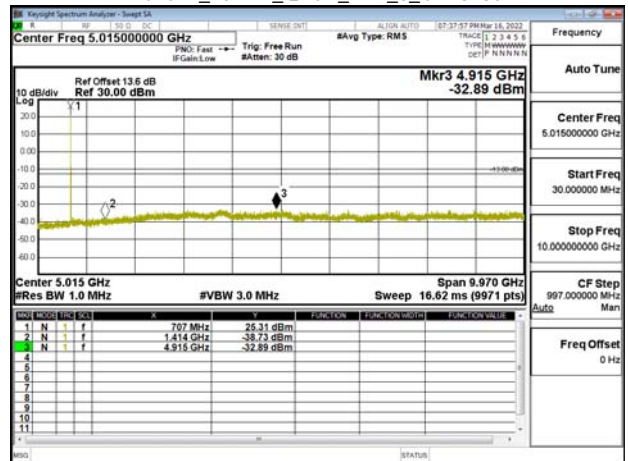

Unless otherwise stated the results shown in this test report refer only to the sample(s) tested and such sample(s) are retained for 90 days only.

除非另有說明，此報告結果僅對測試之樣品負責，同時此樣品僅保留90天。本報告未經本公司書面許可，不可部份複製。

This document is issued by the Company subject to its General Conditions of Service printed overleaf, available on request or accessible at <http://www.sgs.com.tw/Terms-and-Conditions> and for electronic format documents, subject to Terms and Conditions for Electronic Documents at <http://www.sgs.com.tw/Terms-and-Conditions>. Attention is drawn to the limitation of liability, indemnification and jurisdiction issues defined therein. Any holder of this document is advised that information contained herein reflects the Company's findings at the time of its intervention only and within the limits of Client's instructions, if any. The Company's sole responsibility is to its Client and this document does not exonerate parties to a transaction from exercising all their rights and obligations under the transaction documents. This document cannot be reproduced except in full, without prior written approval of the Company. Any unauthorized alteration, forgery or falsification of the content or appearance of this document is unlawful and offenders may be prosecuted to the fullest extent of the law.

Band13_5MHz_QPSK_RB1_0_CH23205

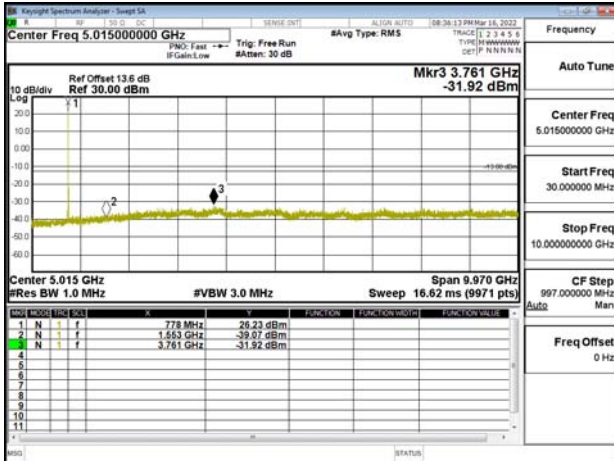

Band13_10MHz_QPSK_RB1_0_CH23230

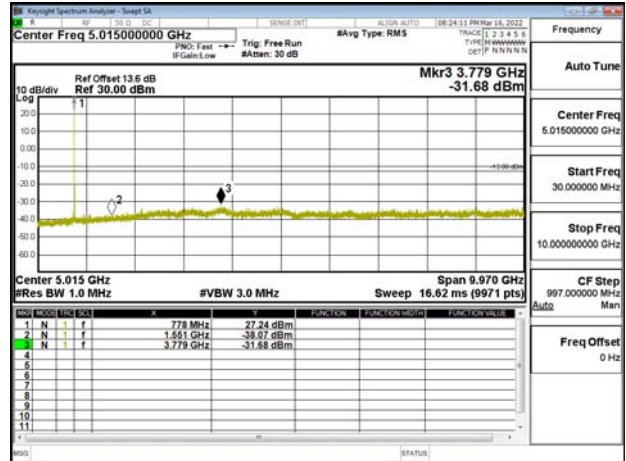

Band13_5MHz_QPSK_RB1_0_CH23230

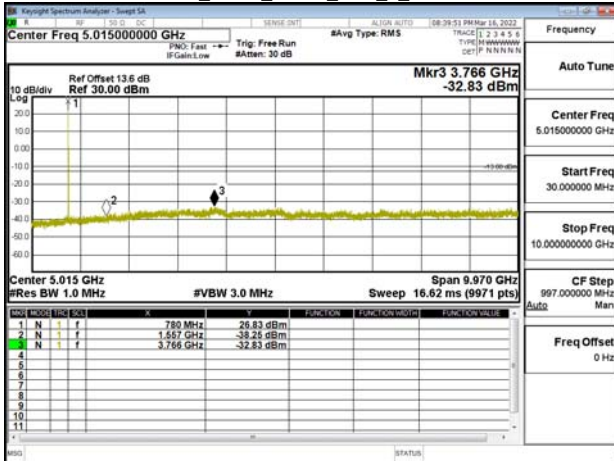

Band17_5MHz_QPSK_RB1_0_CH23755

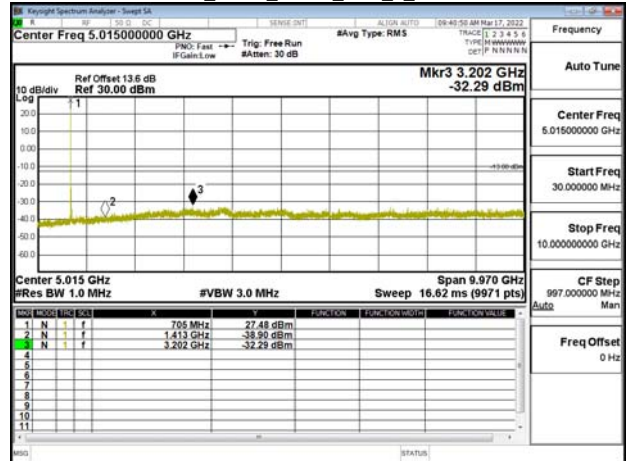

Band13_5MHz_QPSK_RB1_0_CH23255

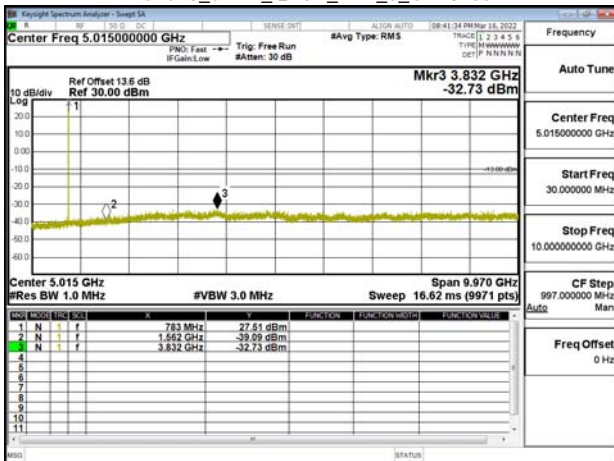

Band17_5MHz_QPSK_RB1_0_CH23790

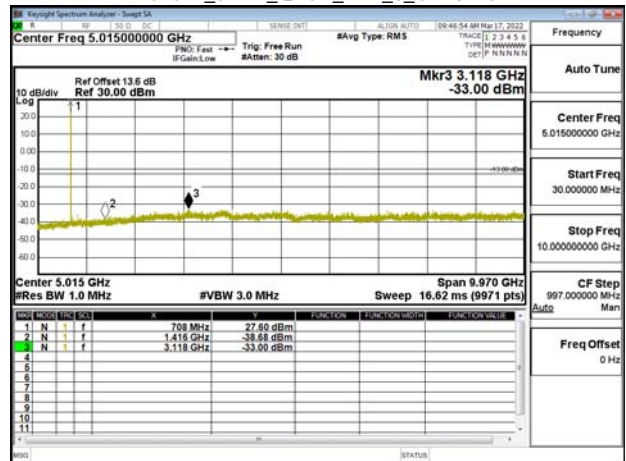

Unless otherwise stated the results shown in this test report refer only to the sample(s) tested and such sample(s) are retained for 90 days only.

除非另有說明，此報告結果僅對測試之樣品負責，同時此樣品僅保留90天。本報告未經本公司書面許可，不可部份複製。

This document is issued by the Company subject to its General Conditions of Service printed overleaf, available on request or accessible at <http://www.sgs.com.tw/Terms-and-Conditions> and for electronic format documents, subject to Terms and Conditions for Electronic Documents at <http://www.sgs.com.tw/Terms-and-Conditions>. Attention is drawn to the limitation of liability, indemnification and jurisdiction issues defined therein. Any holder of this document is advised that information contained herein reflects the Company's findings at the time of its intervention only and within the limits of Client's instructions, if any. The Company's sole responsibility is to its Client and this document does not exonerate parties to a transaction from exercising all their rights and obligations under the transaction documents. This document cannot be reproduced except in full, without prior written approval of the Company. Any unauthorized alteration, forgery or falsification of the content or appearance of this document is unlawful and offenders may be prosecuted to the fullest extent of the law.

Band17_5MHz_QPSK_RB1_0_CH23825

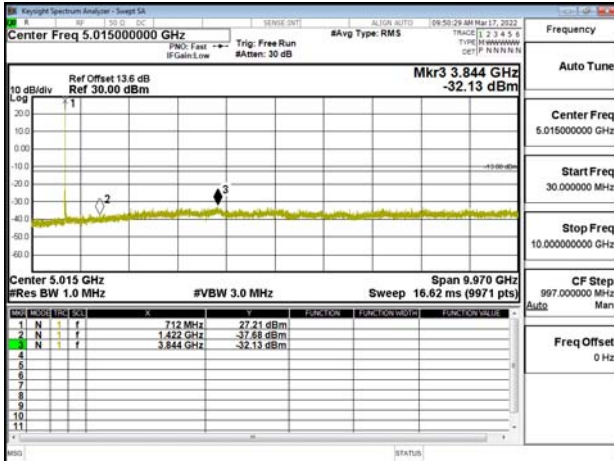

Band17_10MHz_QPSK_RB1_0_CH23800

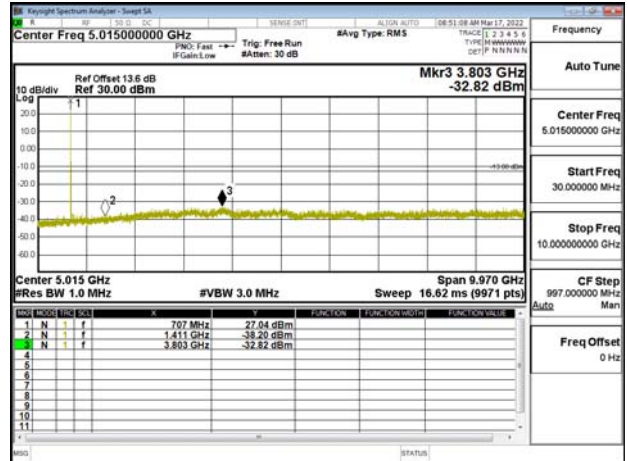

Band17_10MHz_QPSK_RB1_0_CH23780

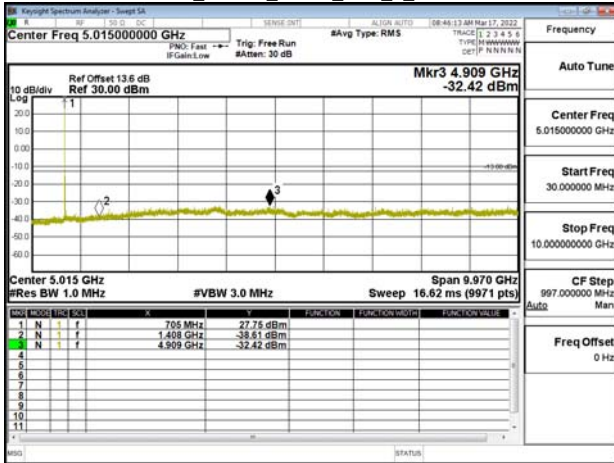

Band66_1.4MHz_QPSK_RB1_0_CH131979

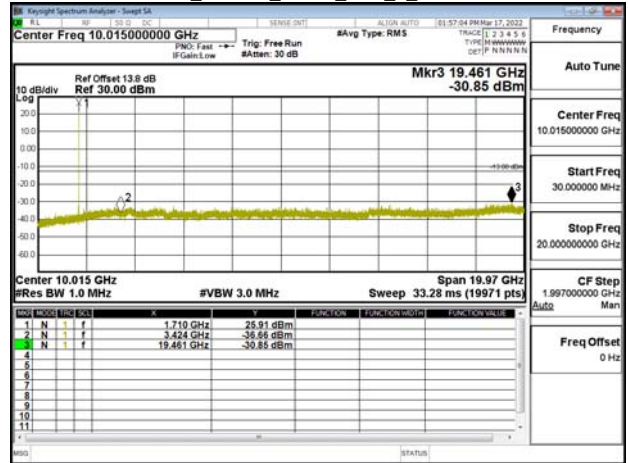

Band17_10MHz_QPSK_RB1_0_CH23790

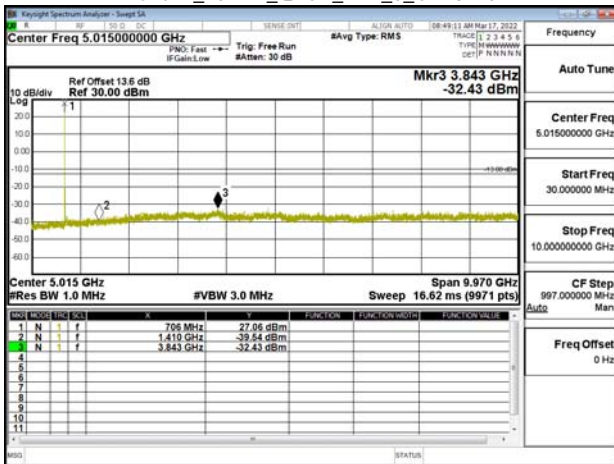

Band66_1.4MHz_QPSK_RB1_0_CH132322

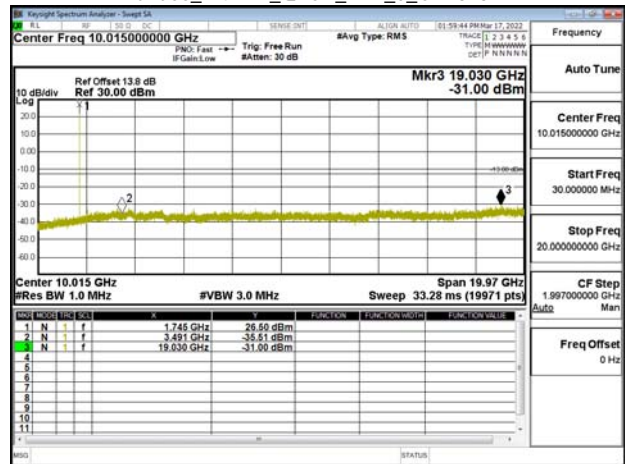

Unless otherwise stated the results shown in this test report refer only to the sample(s) tested and such sample(s) are retained for 90 days only.

除非另有說明，此報告結果僅對測試之樣品負責，同時此樣品僅保留90天。本報告未經本公司書面許可，不可部份複製。

This document is issued by the Company subject to its General Conditions of Service printed overleaf, available on request or accessible at <http://www.sgs.com.tw/Terms-and-Conditions> and for electronic format documents, subject to Terms and Conditions for Electronic Documents at <http://www.sgs.com.tw/Terms-and-Conditions>. Attention is drawn to the limitation of liability, indemnification and jurisdiction issues defined therein. Any holder of this document is advised that information contained herein reflects the Company's findings at the time of its intervention only and within the limits of Client's instructions, if any. The Company's sole responsibility is to its Client and this document does not exonerate parties to a transaction from exercising all their rights and obligations under the transaction documents. This document cannot be reproduced except in full, without prior written approval of the Company. Any unauthorized alteration, forgery or falsification of the content or appearance of this document is unlawful and offenders may be prosecuted to the fullest extent of the law.

Band66_1.4MHz_QPSK_RB1_0_CH132665

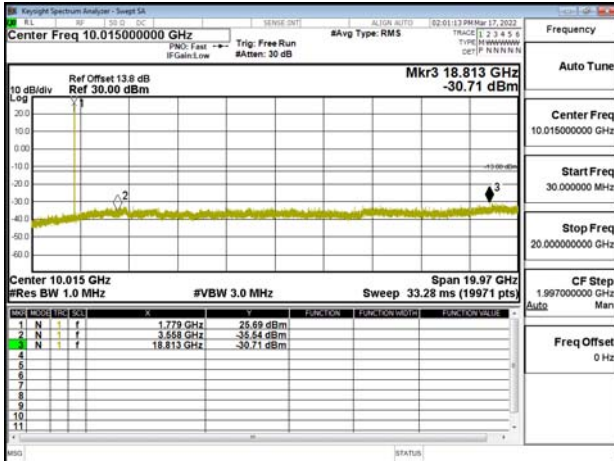

Band66_3MHz_QPSK_RB1_0_CH132657

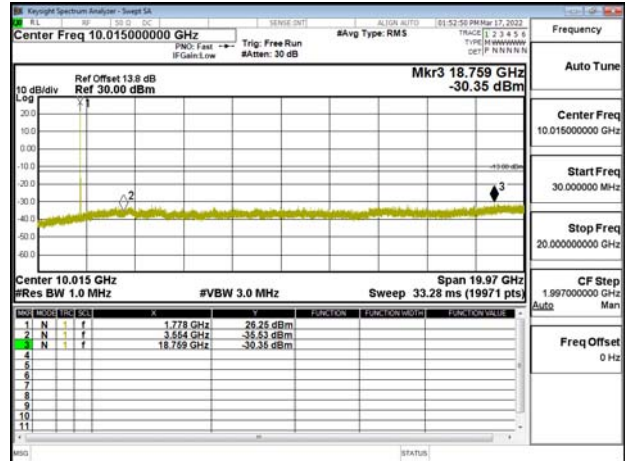

Band66_3MHz_QPSK_RB1_0_CH131987

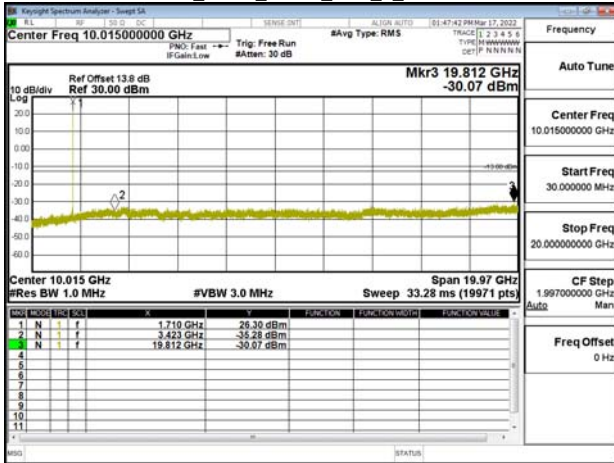

Band66_5MHz_QPSK_RB1_0_CH131997

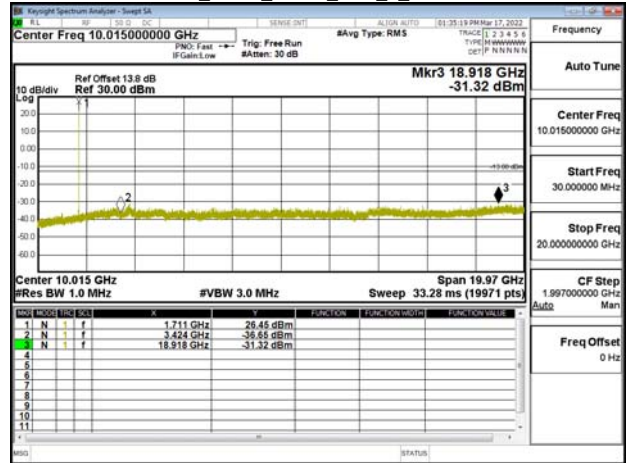

Band66_3MHz_QPSK_RB1_0_CH132322

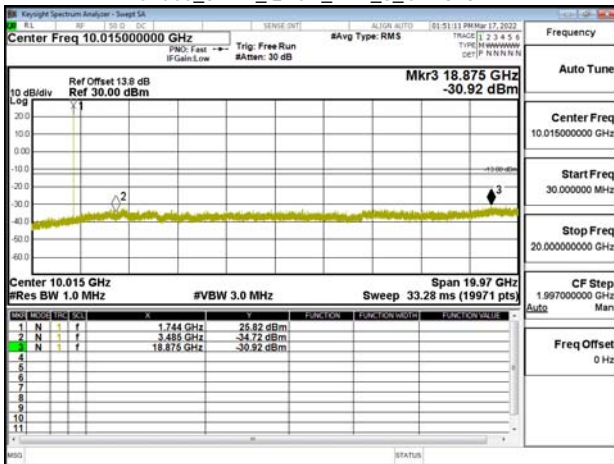

Band66_5MHz_QPSK_RB1_0_CH132322

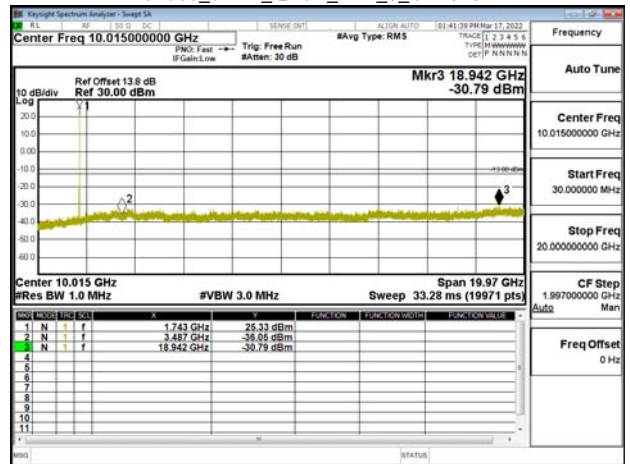

Unless otherwise stated the results shown in this test report refer only to the sample(s) tested and such sample(s) are retained for 90 days only.

除非另有說明，此報告結果僅對測試之樣品負責，同時此樣品僅保留90天。本報告未經本公司書面許可，不可部份複製。

This document is issued by the Company subject to its General Conditions of Service printed overleaf, available on request or accessible at <http://www.sgs.com.tw/Terms-and-Conditions> and for electronic format documents, subject to Terms and Conditions for Electronic Documents at <http://www.sgs.com.tw/Terms-and-Conditions>. Attention is drawn to the limitation of liability, indemnification and jurisdiction issues defined therein. Any holder of this document is advised that information contained herein reflects the Company's findings at the time of its intervention only and within the limits of Client's instructions, if any. The Company's sole responsibility is to its Client and this document does not exonerate parties to a transaction from exercising all their rights and obligations under the transaction documents. This document cannot be reproduced except in full, without prior written approval of the Company. Any unauthorized alteration, forgery or falsification of the content or appearance of this document is unlawful and offenders may be prosecuted to the fullest extent of the law.

Band66_5MHz_OPSK_RB1_0_CH132647

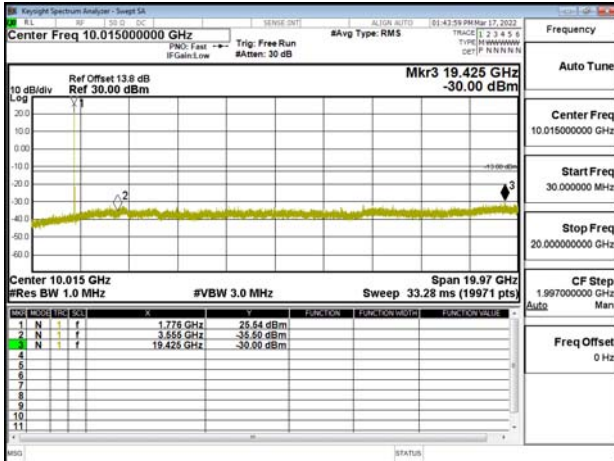

Band66_10MHz_OPSK_RB1_0_CH132622

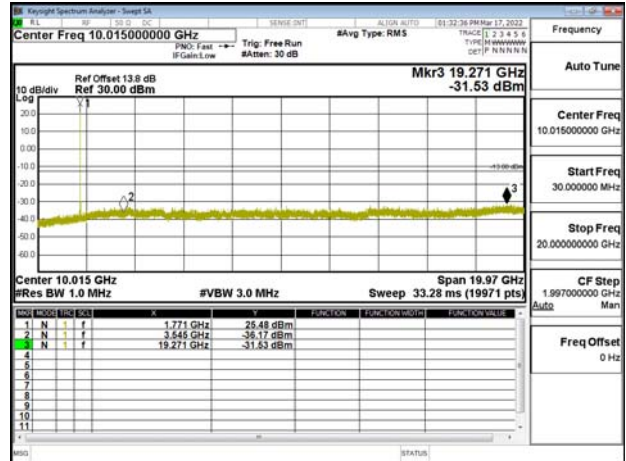

Band66_10MHz_OPSK_RB1_0_CH132022

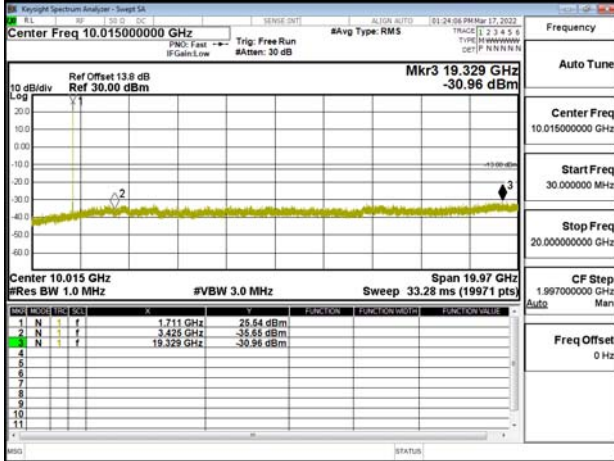

Band66_15MHz_OPSK_RB1_0_CH132047

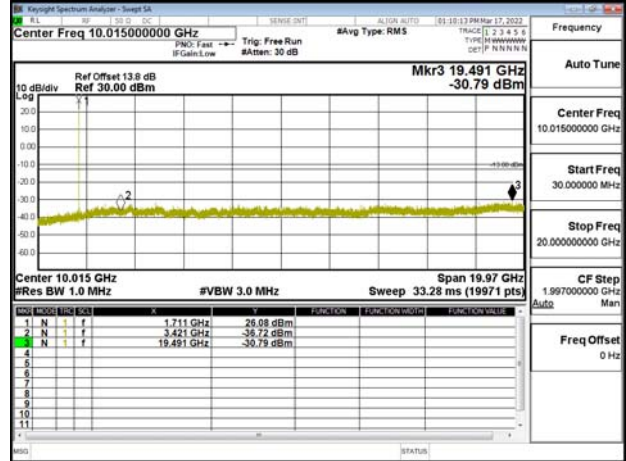

Band66_10MHz_OPSK_RB1_0_CH132322

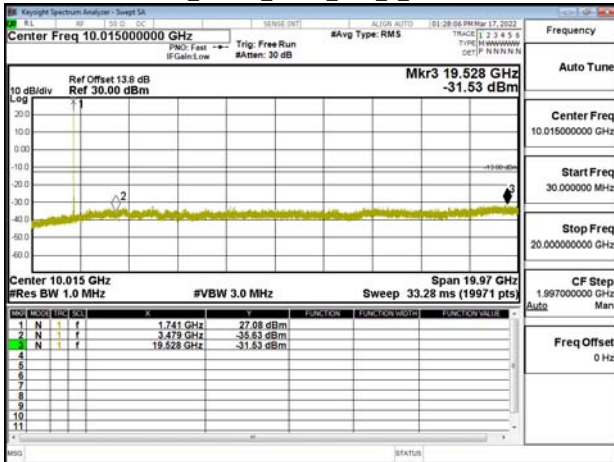

Band66_15MHz_OPSK_RB1_0_CH132322

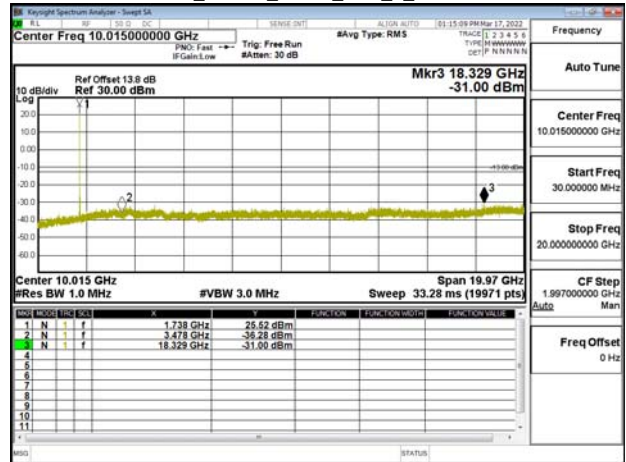

Unless otherwise stated the results shown in this test report refer only to the sample(s) tested and such sample(s) are retained for 90 days only.

除非另有說明，此報告結果僅對測試之樣品負責，同時此樣品僅保留90天。本報告未經本公司書面許可，不可部份複製。

This document is issued by the Company subject to its General Conditions of Service printed overleaf, available on request or accessible at <http://www.sgs.com.tw/Terms-and-Conditions> and for electronic format documents, subject to Terms and Conditions for Electronic Documents at <http://www.sgs.com.tw/Terms-and-Conditions>. Attention is drawn to the limitation of liability, indemnification and jurisdiction issues defined therein. Any holder of this document is advised that information contained herein reflects the Company's findings at the time of its intervention only and within the limits of Client's instructions, if any. The Company's sole responsibility is to its Client and this document does not exonerate parties to a transaction from exercising all their rights and obligations under the transaction documents. This document cannot be reproduced except in full, without prior written approval of the Company. Any unauthorized alteration, forgery or falsification of the content or appearance of this document is unlawful and offenders may be prosecuted to the fullest extent of the law.

Band66_15MHz_QPSK_RB1_0_CH132597

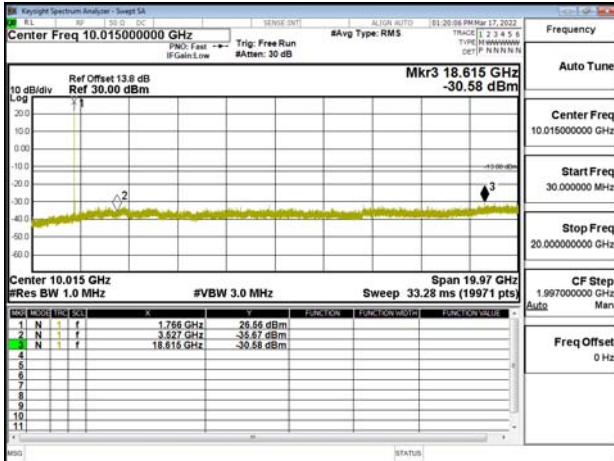

Band66_20MHz_QPSK_RB1_0_CH132572

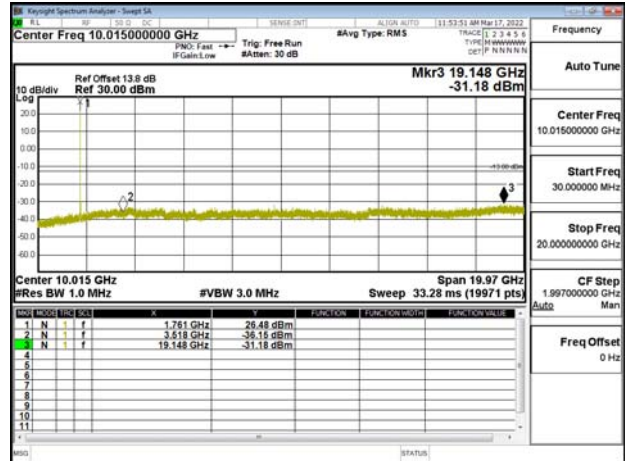

Band66_20MHz_QPSK_RB1_0_CH132072

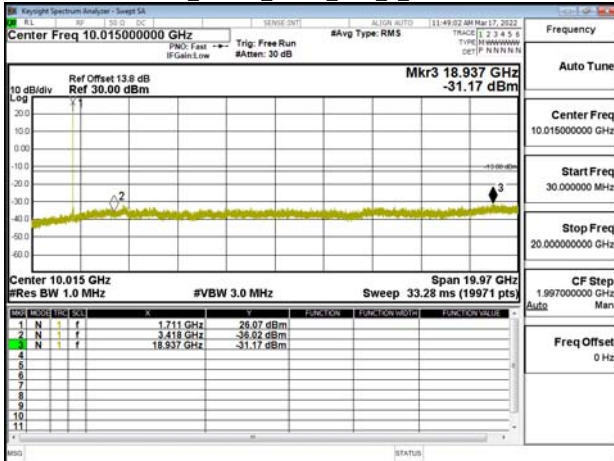

Band66_20MHz_QPSK_RB1_0_CH132322

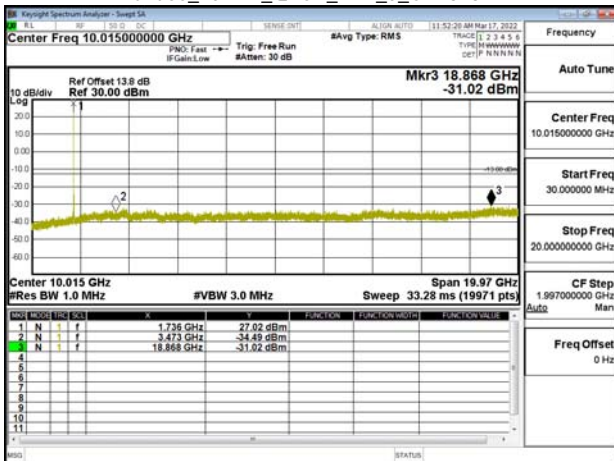

Unless otherwise stated the results shown in this test report refer only to the sample(s) tested and such sample(s) are retained for 90 days only.

除非另有說明，此報告結果僅對測試之樣品負責，同時此樣品僅保留90天。本報告未經本公司書面許可，不可部份複製。

This document is issued by the Company subject to its General Conditions of Service printed overleaf, available on request or accessible at <http://www.sgs.com.tw/Terms-and-Conditions> and for electronic format documents, subject to Terms and Conditions for Electronic Documents at <http://www.sgs.com.tw/Terms-and-Conditions>. Attention is drawn to the limitation of liability, indemnification and jurisdiction issues defined therein. Any holder of this document is advised that information contained herein reflects the Company's findings at the time of its intervention only and within the limits of Client's instructions, if any. The Company's sole responsibility is to its Client and this document does not exonerate parties to a transaction from exercising all their rights and obligations under the transaction documents. This document cannot be reproduced except in full, without prior written approval of the Company. Any unauthorized alteration, forgery or falsification of the content or appearance of this document is unlawful and offenders may be prosecuted to the fullest extent of the law.

10 FIELD STRENGTH OF SPURIOUS RADIATION MEASUREMENT

10.1 Standard Applicable

According to FCC §2.1053,

FCC §22.917(a), §24.238(a), §27.53(h)

RSS-130 §4.7, RSS-132 §5.5, RSS-133 §6.5.1, RSS-139 §6.6

Out of band emissions. The power of any emission outside of the authorized operating frequency ranges must be attenuated below the transmitting power (P) by a factor of at least $43 + 10 \log(P)$ dB.

FCC §27.53(g)

Compliance for operations in the 600 MHz, 698-746 MHz, 746-758 MHz and the 776-788 MHz band with this provision is based on the use of measurement instrumentation employing a resolution bandwidth of 100 kilohertz or greater. However, in the 100 kilohertz bands immediately outside and adjacent to a licensee's frequency block, a resolution bandwidth of at least 30 kHz may be employed.

- (2) On any frequency outside the 776-788 MHz band, the power of any emission shall be attenuated outside the band below the transmitter power (P) by at least $43 + 10 \log(P)$ dB;
- (3) On all frequencies between 763-775 MHz and 793-805 MHz, by a factor not less than $76 + 10 \log(P)$ dB in a 6.25 kHz band segment, for base and fixed stations;
- (4) On all frequencies between 763-775 MHz and 793-805 MHz, by a factor not less than $65 + 10 \log(P)$ dB in a 6.25 kHz band segment, for mobile and portable stations;

FCC §27.53(h)(1)

(h) *AWS emission limits*—(1) *General protection levels*. Except as otherwise specified below, for operations in the 1695-1710 MHz, 1710-1755 MHz, 1755-1780 MHz, 1915-1920 MHz, 1995-2000 MHz, 2000-2020 MHz, 2110-2155 MHz, 2155-2180 MHz, and 2180-2200 bands, the power of any emission outside a licensee's frequency block shall be attenuated below the transmitter power (P) in watts by at least $43 + 10 \log_{10}(P)$ dB.

RSS-130 §4.7.1

Compliance for operations in the 617-652 MHz, 663-698 MHz, 698-756 MHz and the 777-787 MHz band, the unwanted emissions in any 100 kHz bandwidth on any frequency outside the low frequency edge and the high frequency edge of each frequency block range(s), shall be attenuated below the transmitter power, P (dBW), by at least $43 + 10 \log_{10} p$ (watts), dB. However, in the 100 kHz band immediately outside of the equipment's frequency block range, a resolution bandwidth of 30 kHz may be employed.

RSS-130 §4.7.2

In addition to the limit outlined in section 4.7.1 above, equipment operating in the frequency bands 746-756 MHz and 777-787 MHz shall also comply with the following restrictions:

the power of any unwanted emissions in any 6.25 kHz bandwidth for all frequencies between 763-775 MHz and 793-806 MHz shall be attenuated below the transmitter power, P (dBW), by at least:

$76 + 10 \log_{10} p$ (watts), dB, for base and fixed equipment and
 $65 + 10 \log_{10} p$ (watts), dB, for mobile and portable equipment

the e.i.r.p. in the band 1559-1610 MHz shall not exceed -70 dBW/MHz for wideband signal and -80 dBW for discrete emission with bandwidth less than 700 Hz.

RSS-132 §5.5

Mobile and base station equipment shall comply with the limits in (i) and (ii) below.

Unless otherwise stated the results shown in this test report refer only to the sample(s) tested and such sample(s) are retained for 90 days only.

除非另有說明，此報告結果僅對測試之樣品負責，同時此樣品僅保留90天。本報告未經本公司書面許可，不可部份複製。

This document is issued by the Company subject to its General Conditions of Service printed overleaf, available on request or accessible at <http://www.sgs.com.tw/Terms-and-Conditions> and for electronic format documents, subject to Terms and Conditions for Electronic Documents at <http://www.sgs.com.tw/Terms-and-Conditions>. Attention is drawn to the limitation of liability, indemnification and jurisdiction issues defined therein. Any holder of this document is advised that information contained hereon reflects the Company's findings at the time of its intervention only and within the limits of Client's instructions, if any. The Company's sole responsibility is to its Client and this document does not exonerate parties to a transaction from exercising all their rights and obligations under the transaction documents. This document cannot be reproduced except in full, without prior written approval of the Company. Any unauthorized alteration, forgery or falsification of the content or appearance of this document is unlawful and offenders may be prosecuted to the fullest extent of the law.

- i. In the first 1.0 MHz band immediately outside and adjacent to each of the sub-bands specified in Section 5.1, the power of emissions per any 1% of the occupied bandwidth shall be attenuated (in dB) below the transmitter output power P (dBW) by at least $43 + 10 \log_{10} p$ (watts).
- ii. After the first 1.0 MHz immediately outside and adjacent to each of the sub-bands, the power of emissions in any 100 kHz bandwidth shall be attenuated (in dB) below the transmitter output power P (dBW) by at least $43 + 10 \log_{10} p$ (watts). If the measurement is performed using 1% of the occupied bandwidth, power integration over 100 kHz is required.

RSS-133 §6.5.1

Equipment shall comply with the limits in (i) and (ii) below.

- i. In the 1.0 MHz bands immediately outside and adjacent to the equipment's operating frequency block, the emission power per any 1% of the emission bandwidth shall be attenuated (in dB) below the transmitter output power P (dBW) by at least $43 + 10 \log_{10} p$ (watts).
- ii. After the first 1.0 MHz, the emission power in any 1 MHz bandwidth shall be attenuated (in dB) below the transmitter output power P (dBW) by at least $43 + 10 \log_{10} p$ (watts). If the measurement is performed using 1% of the emission bandwidth, power integration over 1.0 MHz is required.

RSS-139 §6.6

In the first 1.0 MHz bands immediately outside and adjacent to the equipment's smallest operating frequency block, Footnote 2 which can contain the equipment's occupied bandwidth, the emission power per any 1% of the emission bandwidth shall be attenuated below the transmitter output power P (in dBW) by at least $43 + 10 \log_{10} p$ (watts) dB.

After the first 1.0 MHz outside the equipment's smallest operating frequency block, which can contain the equipment's occupied bandwidth, the emission power in any 1 MHz bandwidth shall be attenuated below the transmitter output power P (in dBW) by at least $43 + 10 \log_{10} p$ (watts) dB.

Unless otherwise stated the results shown in this test report refer only to the sample(s) tested and such sample(s) are retained for 90 days only.

除非另有說明，此報告結果僅對測試之樣品負責，同時此樣品僅保留90天。本報告未經本公司書面許可，不可部份複製。

This document is issued by the Company subject to its General Conditions of Service printed overleaf, available on request or accessible at <http://www.sgs.com.tw/Terms-and-Conditions> and for electronic format documents, subject to Terms and Conditions for Electronic Documents at <http://www.sgs.com.tw/Terms-and-Conditions>. Attention is drawn to the limitation of liability, indemnification and jurisdiction issues defined therein. Any holder of this document is advised that information contained hereon reflects the Company's findings at the time of its intervention only and within the limits of Client's instructions, if any. The Company's sole responsibility is to its Client and this document does not exonerate parties to a transaction from exercising all their rights and obligations under the transaction documents. This document cannot be reproduced except in full, without prior written approval of the Company. Any unauthorized alteration, forgery or falsification of the content or appearance of this document is unlawful and offenders may be prosecuted to the fullest extent of the law.

10.2 EUT Setup

Radiated Emission Test Set-Up, Frequency Below 1000MHz

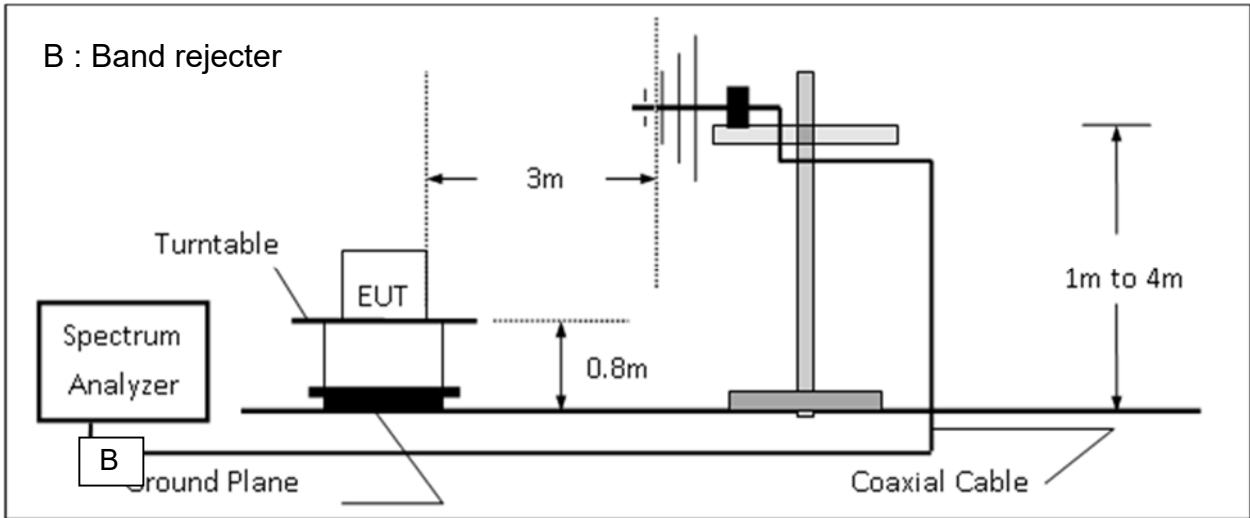

Radiated Emission Test Set-UP Frequency Over 1 GHz

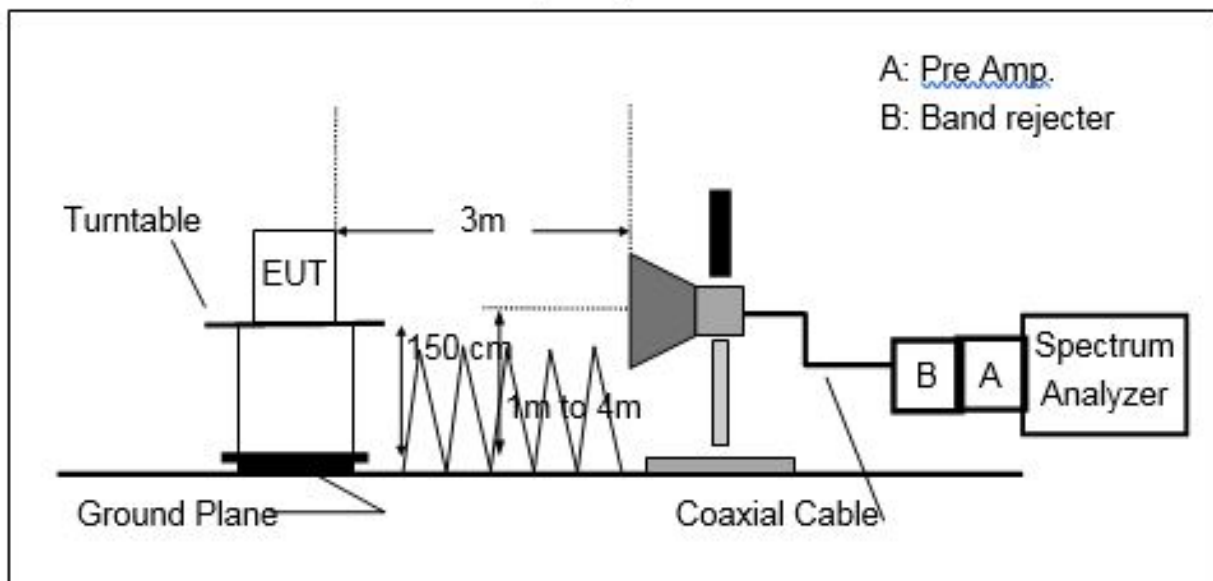

Unless otherwise stated the results shown in this test report refer only to the sample(s) tested and such sample(s) are retained for 90 days only.

除非另有說明，此報告結果僅對測試之樣品負責，同時此樣品僅保留90天。本報告未經本公司書面許可，不可部份複製。

This document is issued by the Company subject to its General Conditions of Service printed overleaf, available on request or accessible at <http://www.sgs.com.tw/Terms-and-Conditions> and for electronic format documents, subject to Terms and Conditions for Electronic Documents at <http://www.sgs.com.tw/Terms-and-Conditions>. Attention is drawn to the limitation of liability, indemnification and jurisdiction issues defined therein. Any holder of this document is advised that information contained hereon reflects the Company's findings at the time of its intervention only and within the limits of Client's instructions, if any. The Company's sole responsibility is to its Client and this document does not exonerate parties to a transaction from exercising all their rights and obligations under the transaction documents. This document cannot be reproduced except in full, without prior written approval of the Company. Any unauthorized alteration, forgery or falsification of the content or appearance of this document is unlawful and offenders may be prosecuted to the fullest extent of the law.

10.3 Measurement Procedure:

The EUT was placed on a non-conductive; the measurement antenna was placed at a distance of 3 meters from the EUT. During the tests, the antenna height and the EUT azimuth were varied in order to identify the maximum level of emissions from the EUT. This maximization process was repeated with the EUT positioned in each of its three orthogonal orientations.

The frequency range up to tenth harmonic was investigated for each of three fundamental frequencies (low, middle and high channels). Once spurious emission was identified, the power of the emission was determined using the substitution method.

The spurious emissions attenuation was calculated as the difference between radiated power at the fundamental frequency and the spurious emissions frequency.

ERP (dBm) = SG Level(dBm) + Antenna Gain(dBd) + Cable Loss(dB)

EIRP (dBm) = SG Level(dBm) + Antenna Gain(dBi) + Cable Loss(dB)

Unless otherwise stated the results shown in this test report refer only to the sample(s) tested and such sample(s) are retained for 90 days only.
除非另有說明，此報告結果僅對測試之樣品負責，同時此樣品僅保留90天。本報告未經本公司書面許可，不可部份複製。

This document is issued by the Company subject to its General Conditions of Service printed overleaf, available on request or accessible at <http://www.sgs.com.tw/Terms-and-Conditions> and for electronic format documents, subject to Terms and Conditions for Electronic Documents at <http://www.sgs.com.tw/Terms-and-Conditions>. Attention is drawn to the limitation of liability, indemnification and jurisdiction issues defined therein. Any holder of this document is advised that information contained hereon reflects the Company's findings at the time of its intervention only and within the limits of Client's instructions, if any. The Company's sole responsibility is to its Client and this document does not exonerate parties to a transaction from exercising all their rights and obligations under the transaction documents. This document cannot be reproduced except in full, without prior written approval of the Company. Any unauthorized alteration, forgery or falsification of the content or appearance of this document is unlawful and offenders may be prosecuted to the fullest extent of the law.

10.4 Measurement Result:

Report Number :E2/2022/20116
 Operation Mode :LTE B2
 Test Mode :TX CH LOW
 EUT Pol :E2 Plane
 Test Frequency :1852.5 MHz

Test Site :SAC D
 Test Date :2022-03-22
 Temp./Humi. :20.3/70
 Antenna Pol. :Vertical
 Engineer :Jack Tseng

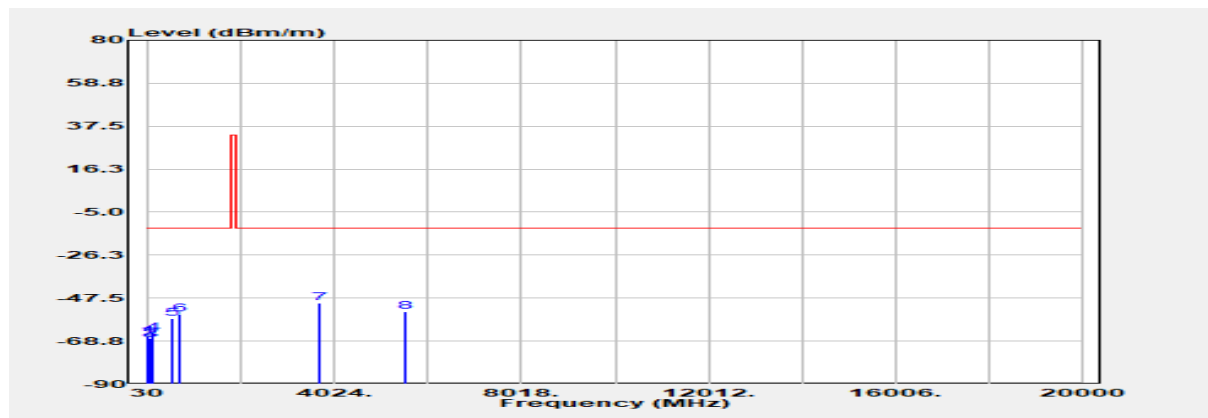

Freq. MHz	EIRP/ERP dBm	SG Output Level dBm	Antenna Gain dBi/dBd	Cable Loss dB	Limit dBm	Margin dB
60.070	-66.47	-51.25	-14.77	-0.45	-13.00	-53.47
82.380	-67.57	-59.33	-7.71	-0.53	-13.00	-54.57
110.510	-68.13	-61.05	-6.47	-0.61	-13.00	-55.13
176.470	-64.99	-59.79	-4.41	-0.79	-13.00	-51.99
593.570	-57.75	-55.2	-1.14	-1.41	-13.00	-44.75
734.220	-55.37	-52.2	-1.20	-1.97	-13.00	-42.37
3705.000	-49.86	-58.31	12.31	-3.86	-13.00	-36.86
5557.500	-54.42	-62.79	12.92	-4.55	-13.00	-41.42

Unless otherwise stated the results shown in this test report refer only to the sample(s) tested and such sample(s) are retained for 90 days only.

除非另有說明，此報告結果僅對測試之樣品負責，同時此樣品僅保留90天。本報告未經本公司書面許可，不可部份複製。

This document is issued by the Company subject to its General Conditions of Service printed overleaf, available on request or accessible at <http://www.sgs.com.tw/Terms-and-Conditions> and for electronic format documents, subject to Terms and Conditions for Electronic Documents at <http://www.sgs.com.tw/Terms-and-Conditions>. Attention is drawn to the limitation of liability, indemnification and jurisdiction issues defined therein. Any holder of this document is advised that information contained hereon reflects the Company's findings at the time of its intervention only and within the limits of Client's instructions, if any. The Company's sole responsibility is to its Client and this document does not exonerate parties to a transaction from exercising all their rights and obligations under the transaction documents. This document cannot be reproduced except in full, without prior written approval of the Company. Any unauthorized alteration, forgery or falsification of the content or appearance of this document is unlawful and offenders may be prosecuted to the fullest extent of the law.

Report Number :E2/2022/20116
 Operation Mode :LTE B2
 Test Mode :TX CH LOW
 EUT Pol :E2 Plane
 Test Frequency :1852.5 MHz

Test Site :SAC D
 Test Date :2022-03-22
 Temp./Humi. :20.3/70
 Antenna Pol. :Horizontal
 Engineer :Jack Tseng

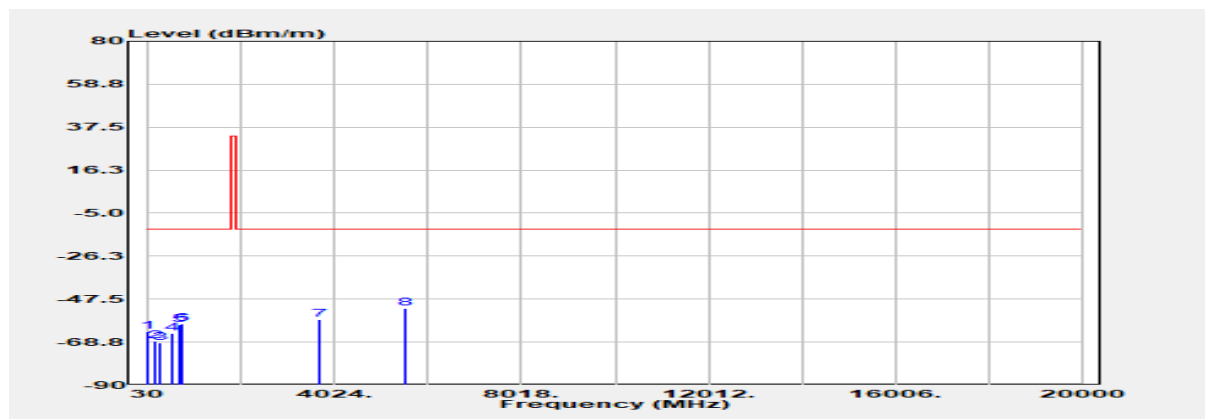

Freq. MHz	EIRP/ERP dBm	SG Output Level dBm	Antenna Gain dBi/dBd	Cable Loss dB	Limit dBm	Margin dB
31.940	-63.57	-43.69	-19.56	-0.32	-13.00	-50.57
182.290	-68.33	-64.23	-3.30	-0.80	-13.00	-55.33
302.570	-69.28	-67.22	-0.97	-1.09	-13.00	-56.28
584.840	-64.31	-61.66	-1.00	-1.65	-13.00	-51.31
734.220	-60.34	-57.17	-1.20	-1.97	-13.00	-47.34
776.900	-59.80	-56.84	-1.57	-1.39	-13.00	-46.80
3705.000	-57.55	-66	12.31	-3.86	-13.00	-44.55
5557.500	-52.07	-60.44	12.92	-4.55	-13.00	-39.07

Unless otherwise stated the results shown in this test report refer only to the sample(s) tested and such sample(s) are retained for 90 days only.

除非另有說明，此報告結果僅對測試之樣品負責，同時此樣品僅保留90天。本報告未經本公司書面許可，不可部份複製。

This document is issued by the Company subject to its General Conditions of Service printed overleaf, available on request or accessible at <http://www.sgs.com.tw/Terms-and-Conditions> and for electronic format documents, subject to Terms and Conditions for Electronic Documents at <http://www.sgs.com.tw/Terms-and-Conditions>. Attention is drawn to the limitation of liability, indemnification and jurisdiction issues defined therein. Any holder of this document is advised that information contained hereon reflects the Company's findings at the time of its intervention only and within the limits of Client's instructions, if any. The Company's sole responsibility is to its Client and this document does not exonerate parties to a transaction from exercising all their rights and obligations under the transaction documents. This document cannot be reproduced except in full, without prior written approval of the Company. Any unauthorized alteration, forgery or falsification of the content or appearance of this document is unlawful and offenders may be prosecuted to the fullest extent of the law.

Report Number :E2/2022/20116
 Operation Mode :LTE B2
 Test Mode :TX CH MID
 EUT Pol :E2 Plane
 Test Frequency :1880 MHz

Test Site :SAC D
 Test Date :2022-03-22
 Temp./Humi. :20.3/70
 Antenna Pol. :Vertical
 Engineer :Jack Tseng

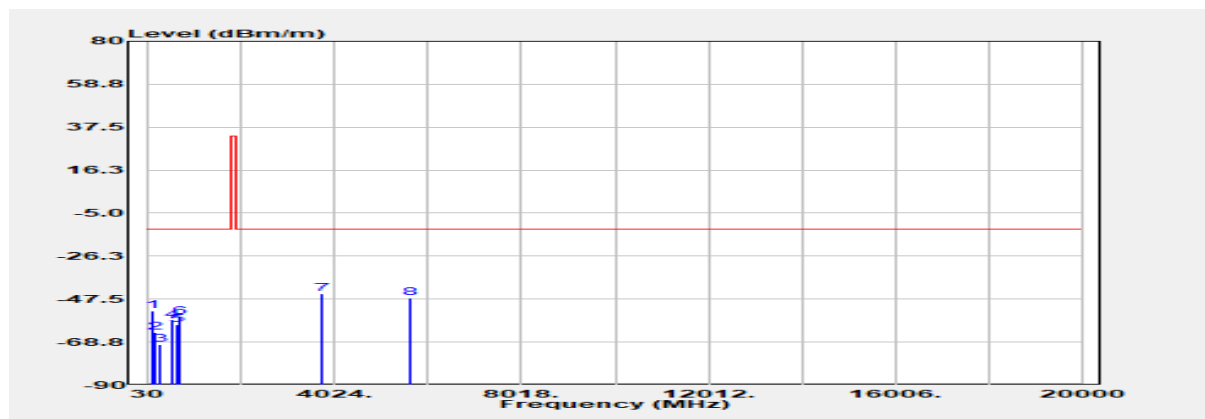

Freq. MHz	EIRP/ERP dBm	SG Output Level dBm	Antenna Gain dBi/dBd	Cable Loss dB	Limit dBm	Margin dB
178.410	-53.48	-48.62	-4.07	-0.79	-13.00	-40.48
227.880	-64.04	-63.32	0.18	-0.90	-13.00	-51.04
300.630	-69.88	-67.82	-0.99	-1.07	-13.00	-56.88
589.690	-58.23	-55.59	-1.11	-1.53	-13.00	-45.23
672.140	-60.14	-57.47	-0.99	-1.68	-13.00	-47.14
737.130	-56.19	-52.98	-1.27	-1.94	-13.00	-43.19
3760.000	-44.83	-53.49	12.40	-3.74	-13.00	-31.83
5640.000	-46.77	-55.02	13.00	-4.75	-13.00	-33.77

Unless otherwise stated the results shown in this test report refer only to the sample(s) tested and such sample(s) are retained for 90 days only.

除非另有說明，此報告結果僅對測試之樣品負責，同時此樣品僅保留90天。本報告未經本公司書面許可，不可部份複製。

This document is issued by the Company subject to its General Conditions of Service printed overleaf, available on request or accessible at <http://www.sgs.com.tw/Terms-and-Conditions> and for electronic format documents, subject to Terms and Conditions for Electronic Documents at <http://www.sgs.com.tw/Terms-and-Conditions>. Attention is drawn to the limitation of liability, indemnification and jurisdiction issues defined therein. Any holder of this document is advised that information contained hereon reflects the Company's findings at the time of its intervention only and within the limits of Client's instructions, if any. The Company's sole responsibility is to its Client and this document does not exonerate parties to a transaction from exercising all their rights and obligations under the transaction documents. This document cannot be reproduced except in full, without prior written approval of the Company. Any unauthorized alteration, forgery or falsification of the content or appearance of this document is unlawful and offenders may be prosecuted to the fullest extent of the law.

Report Number :E2/2022/20116
 Operation Mode :LTE B2
 Test Mode :TX CH MID
 EUT Pol :E2 Plane
 Test Frequency :1880 MHz

Test Site :SAC D
 Test Date :2022-03-22
 Temp./Humi. :20.3/70
 Antenna Pol. :Horizontal
 Engineer :Jack Tseng

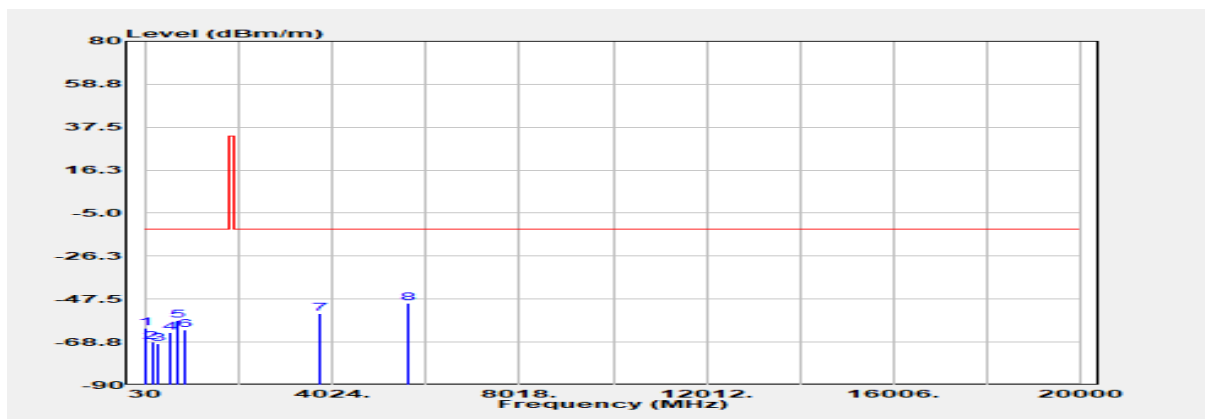

Freq. MHz	EIRP/ERP dBm	SG Output Level dBm	Antenna Gain dBi/dBd	Cable Loss dB	Limit dBm	Margin dB
31.940	-62.02	-42.14	-19.56	-0.32	-13.00	-49.02
181.320	-68.83	-64.52	-3.51	-0.80	-13.00	-55.83
297.720	-69.66	-67.58	-1.02	-1.06	-13.00	-56.66
596.480	-63.90	-61.39	-1.19	-1.32	-13.00	-50.90
737.130	-58.19	-54.98	-1.27	-1.94	-13.00	-45.19
867.110	-62.76	-59.98	-1.18	-1.60	-13.00	-49.76
3760.000	-54.53	-63.19	12.40	-3.74	-13.00	-41.53
5640.000	-49.45	-57.7	13.00	-4.75	-13.00	-36.45

Unless otherwise stated the results shown in this test report refer only to the sample(s) tested and such sample(s) are retained for 90 days only.

除非另有說明，此報告結果僅對測試之樣品負責，同時此樣品僅保留90天。本報告未經本公司書面許可，不可部份複製。

This document is issued by the Company subject to its General Conditions of Service printed overleaf, available on request or accessible at <http://www.sgs.com.tw/Terms-and-Conditions> and for electronic format documents, subject to Terms and Conditions for Electronic Documents at <http://www.sgs.com.tw/Terms-and-Conditions>. Attention is drawn to the limitation of liability, indemnification and jurisdiction issues defined therein. Any holder of this document is advised that information contained hereon reflects the Company's findings at the time of its intervention only and within the limits of Client's instructions, if any. The Company's sole responsibility is to its Client and this document does not exonerate parties to a transaction from exercising all their rights and obligations under the transaction documents. This document cannot be reproduced except in full, without prior written approval of the Company. Any unauthorized alteration, forgery or falsification of the content or appearance of this document is unlawful and offenders may be prosecuted to the fullest extent of the law.

Report Number :E2/2022/20116
 Operation Mode :LTE B2
 Test Mode :TX CH HIGH
 EUT Pol :E2 Plane
 Test Frequency :1907.5 MHz

Test Site :SAC D
 Test Date :2022-03-22
 Temp./Humi. :20.3/70
 Antenna Pol. :Vertical
 Engineer :Jack Tseng

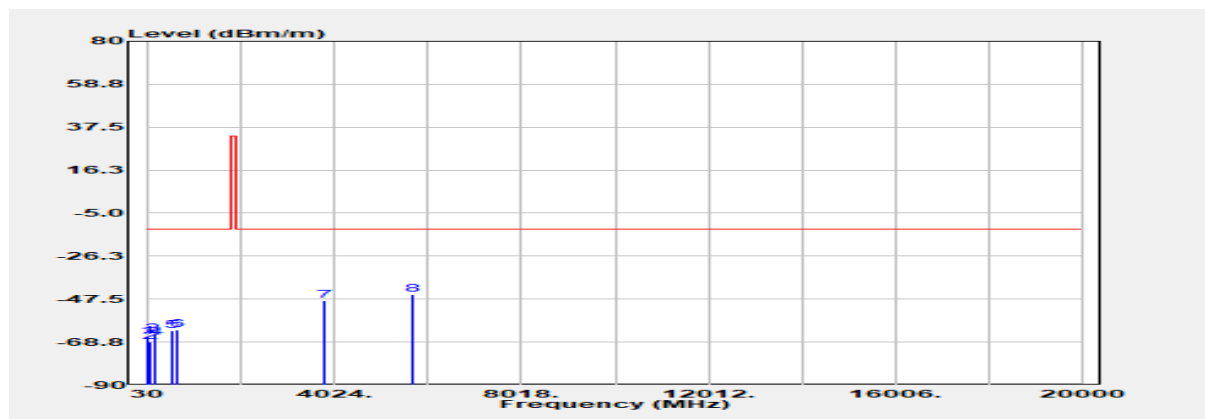

Freq. MHz	EIRP/ERP dBm	SG Output Level dBm	Antenna Gain dBi/dBd	Cable Loss dB	Limit dBm	Margin dB
60.070	-66.24	-51.02	-14.77	-0.45	-13.00	-53.24
109.540	-68.89	-61.82	-6.46	-0.61	-13.00	-55.89
181.320	-64.66	-60.35	-3.51	-0.80	-13.00	-51.66
226.910	-66.63	-65.96	0.22	-0.89	-13.00	-53.63
570.290	-63.06	-60.45	-0.83	-1.78	-13.00	-50.06
674.080	-62.69	-60.1	-0.96	-1.63	-13.00	-49.69
3815.000	-48.12	-56.7	12.37	-3.79	-13.00	-35.12
5722.500	-45.17	-53.24	12.80	-4.73	-13.00	-32.17

Unless otherwise stated the results shown in this test report refer only to the sample(s) tested and such sample(s) are retained for 90 days only.

除非另有說明，此報告結果僅對測試之樣品負責，同時此樣品僅保留90天。本報告未經本公司書面許可，不可部份複製。

This document is issued by the Company subject to its General Conditions of Service printed overleaf, available on request or accessible at <http://www.sgs.com.tw/Terms-and-Conditions> and for electronic format documents, subject to Terms and Conditions for Electronic Documents at <http://www.sgs.com.tw/Terms-and-Conditions>. Attention is drawn to the limitation of liability, indemnification and jurisdiction issues defined therein. Any holder of this document is advised that information contained hereon reflects the Company's findings at the time of its intervention only and within the limits of Client's instructions, if any. The Company's sole responsibility is to its Client and this document does not exonerate parties to a transaction from exercising all their rights and obligations under the transaction documents. This document cannot be reproduced except in full, without prior written approval of the Company. Any unauthorized alteration, forgery or falsification of the content or appearance of this document is unlawful and offenders may be prosecuted to the fullest extent of the law.

Report Number :E2/2022/20116
 Operation Mode :LTE B2
 Test Mode :TX CH HIGH
 EUT Pol :E2 Plane
 Test Frequency :1907.5 MHz

Test Site :SAC D
 Test Date :2022-03-22
 Temp./Humi. :20.3/70
 Antenna Pol. :Horizontal
 Engineer :Jack Tseng

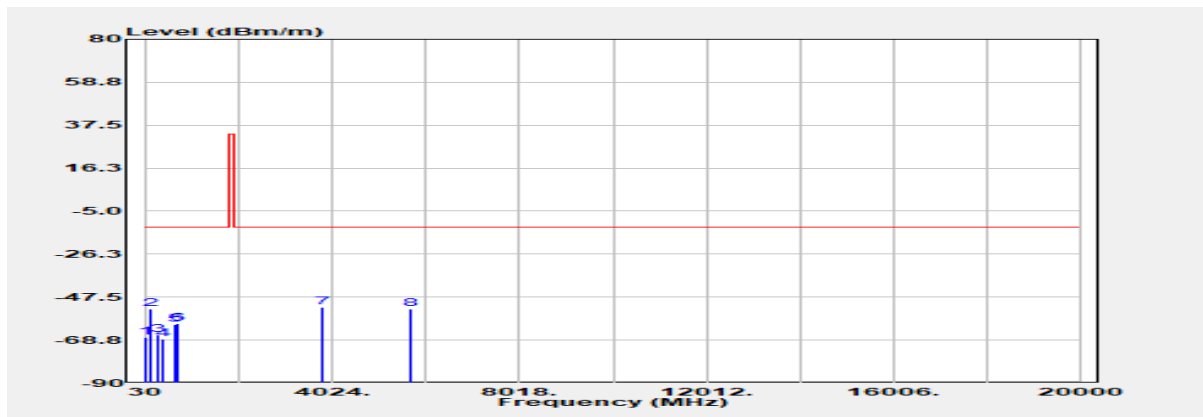

Freq. MHz	EIRP/ERP dBm	SG Output Level dBm	Antenna Gain dBi/dBd	Cable Loss dB	Limit dBm	Margin dB
33.880	-67.55	-47.91	-19.31	-0.33	-13.00	-54.55
179.380	-53.22	-48.5	-3.92	-0.80	-13.00	-40.22
299.660	-65.95	-63.88	-1.00	-1.07	-13.00	-52.95
401.510	-68.35	-66.32	-0.63	-1.40	-13.00	-55.35
660.500	-61.22	-58.4	-0.96	-1.86	-13.00	-48.22
745.860	-60.51	-57.22	-1.51	-1.78	-13.00	-47.51
3815.000	-52.70	-61.28	12.37	-3.79	-13.00	-39.70
5722.500	-53.27	-61.34	12.80	-4.73	-13.00	-40.27

Unless otherwise stated the results shown in this test report refer only to the sample(s) tested and such sample(s) are retained for 90 days only.

除非另有說明，此報告結果僅對測試之樣品負責，同時此樣品僅保留90天。本報告未經本公司書面許可，不可部份複製。
 This document is issued by the Company subject to its General Conditions of Service printed overleaf, available on request or accessible at <http://www.sgs.com.tw/Terms-and-Conditions> and for electronic format documents, subject to Terms and Conditions for Electronic Documents at <http://www.sgs.com.tw/Terms-and-Conditions>. Attention is drawn to the limitation of liability, indemnification and jurisdiction issues defined therein. Any holder of this document is advised that information contained hereon reflects the Company's findings at the time of its intervention only and within the limits of Client's instructions, if any. The Company's sole responsibility is to its Client and this document does not exonerate parties to a transaction from exercising all their rights and obligations under the transaction documents. This document cannot be reproduced except in full, without prior written approval of the Company. Any unauthorized alteration, forgery or falsification of the content or appearance of this document is unlawful and offenders may be prosecuted to the fullest extent of the law.

Report Number :E2/2022/20116
 Operation Mode :LTE B4
 Test Mode :TX CH LOW
 EUT Pol :E2 Plane
 Test Frequency :1717.5 MHz

Test Site :SAC D
 Test Date :2022-03-22
 Temp./Humi. :20.3/70
 Antenna Pol. :Vertical
 Engineer :Jack Tseng

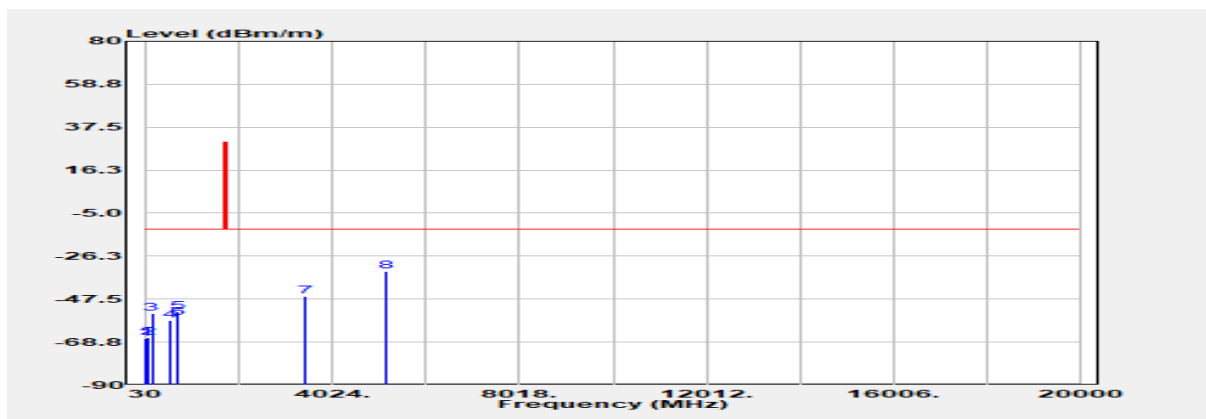

Freq. MHz	EIRP/ERP dBm	SG Output Level dBm	Antenna Gain dBi/dBd	Cable Loss dB	Limit dBm	Margin dB
61.040	-66.79	-51.73	-14.61	-0.45	-13.00	-53.79
108.570	-66.49	-59.6	-6.28	-0.61	-13.00	-53.49
181.320	-54.53	-50.22	-3.51	-0.80	-13.00	-41.53
587.750	-57.86	-55.21	-1.07	-1.58	-13.00	-44.86
737.130	-53.79	-50.58	-1.27	-1.94	-13.00	-40.79
745.860	-56.63	-53.34	-1.51	-1.78	-13.00	-43.63
3435.000	-46.21	-55.07	12.53	-3.67	-13.00	-33.21
5152.500	-33.83	-41.46	12.12	-4.49	-13.00	-20.83

Unless otherwise stated the results shown in this test report refer only to the sample(s) tested and such sample(s) are retained for 90 days only.

除非另有說明，此報告結果僅對測試之樣品負責，同時此樣品僅保留90天。本報告未經本公司書面許可，不可部份複製。

This document is issued by the Company subject to its General Conditions of Service printed overleaf, available on request or accessible at <http://www.sgs.com.tw/Terms-and-Conditions> and for electronic format documents, subject to Terms and Conditions for Electronic Documents at <http://www.sgs.com.tw/Terms-and-Conditions>. Attention is drawn to the limitation of liability, indemnification and jurisdiction issues defined therein. Any holder of this document is advised that information contained hereon reflects the Company's findings at the time of its intervention only and within the limits of Client's instructions, if any. The Company's sole responsibility is to its Client and this document does not exonerate parties to a transaction from exercising all their rights and obligations under the transaction documents. This document cannot be reproduced except in full, without prior written approval of the Company. Any unauthorized alteration, forgery or falsification of the content or appearance of this document is unlawful and offenders may be prosecuted to the fullest extent of the law.

Report Number :E2/2022/20116
 Operation Mode :LTE B4
 Test Mode :TX CH LOW
 EUT Pol :E2 Plane
 Test Frequency :1717.5 MHz

Test Site :SAC D
 Test Date :2022-03-22
 Temp./Humi. :20.3/70
 Antenna Pol. :Horizontal
 Engineer :Jack Tseng

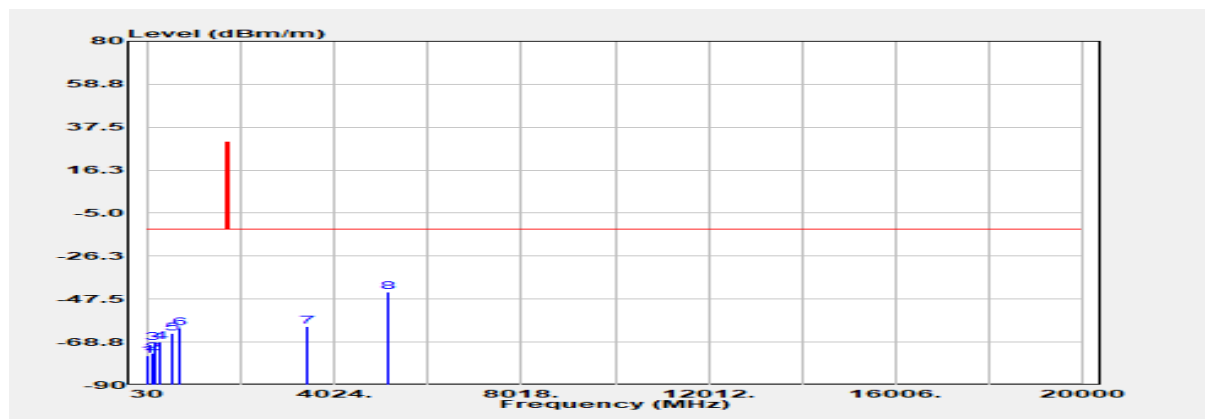

Freq. MHz	EIRP/ERP dBm	SG Output Level dBm	Antenna Gain dBi/dBd	Cable Loss dB	Limit dBm	Margin dB
60.070	-75.41	-60.19	-14.77	-0.45	-13.00	-62.41
142.520	-74.35	-66.67	-7.01	-0.67	-13.00	-61.35
180.350	-68.96	-64.41	-3.75	-0.80	-13.00	-55.96
297.720	-68.90	-66.82	-1.02	-1.06	-13.00	-55.90
589.690	-64.33	-61.69	-1.11	-1.53	-13.00	-51.33
733.250	-61.99	-58.82	-1.20	-1.97	-13.00	-48.99
3435.000	-61.20	-70.06	12.53	-3.67	-13.00	-48.20
5152.500	-43.93	-51.56	12.12	-4.49	-13.00	-30.93

Unless otherwise stated the results shown in this test report refer only to the sample(s) tested and such sample(s) are retained for 90 days only.

除非另有說明，此報告結果僅對測試之樣品負責，同時此樣品僅保留90天。本報告未經本公司書面許可，不可部份複製。

This document is issued by the Company subject to its General Conditions of Service printed overleaf, available on request or accessible at <http://www.sgs.com.tw/Terms-and-Conditions> and for electronic format documents, subject to Terms and Conditions for Electronic Documents at <http://www.sgs.com.tw/Terms-and-Conditions>. Attention is drawn to the limitation of liability, indemnification and jurisdiction issues defined therein. Any holder of this document is advised that information contained hereon reflects the Company's findings at the time of its intervention only and within the limits of Client's instructions, if any. The Company's sole responsibility is to its Client and this document does not exonerate parties to a transaction from exercising all their rights and obligations under the transaction documents. This document cannot be reproduced except in full, without prior written approval of the Company. Any unauthorized alteration, forgery or falsification of the content or appearance of this document is unlawful and offenders may be prosecuted to the fullest extent of the law.

Report Number :E2/2022/20116
 Operation Mode :LTE B4
 Test Mode :TX CH MID
 EUT Pol :E2 Plane
 Test Frequency :1732.5 MHz

Test Site :SAC D
 Test Date :2022-03-22
 Temp./Humi. :20.3/70
 Antenna Pol. :Vertical
 Engineer :Jack Tseng

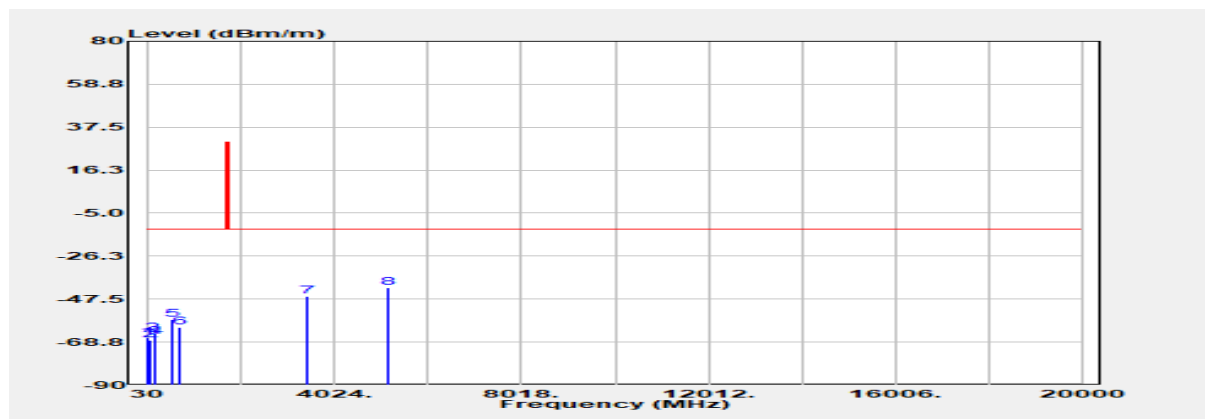

Freq. MHz	EIRP/ERP dBm	SG Output Level dBm	Antenna Gain dBi/dBd	Cable Loss dB	Limit dBm	Margin dB
61.040	-66.48	-51.42	-14.61	-0.45	-13.00	-53.48
108.570	-68.06	-61.17	-6.28	-0.61	-13.00	-55.06
181.320	-64.29	-59.98	-3.51	-0.80	-13.00	-51.29
226.910	-66.34	-65.67	0.22	-0.89	-13.00	-53.34
594.540	-57.53	-55	-1.15	-1.38	-13.00	-44.53
732.280	-61.66	-58.49	-1.19	-1.98	-13.00	-48.66
3465.000	-45.92	-54.7	12.47	-3.69	-13.00	-32.92
5197.500	-41.71	-49.6	12.39	-4.50	-13.00	-28.71

Unless otherwise stated the results shown in this test report refer only to the sample(s) tested and such sample(s) are retained for 90 days only.

除非另有說明，此報告結果僅對測試之樣品負責，同時此樣品僅保留90天。本報告未經本公司書面許可，不可部份複製。
 This document is issued by the Company subject to its General Conditions of Service printed overleaf, available on request or accessible at <http://www.sgs.com.tw/Terms-and-Conditions> and for electronic format documents, subject to Terms and Conditions for Electronic Documents at <http://www.sgs.com.tw/Terms-and-Conditions>. Attention is drawn to the limitation of liability, indemnification and jurisdiction issues defined therein. Any holder of this document is advised that information contained hereon reflects the Company's findings at the time of its intervention only and within the limits of Client's instructions, if any. The Company's sole responsibility is to its Client and this document does not exonerate parties to a transaction from exercising all their rights and obligations under the transaction documents. This document cannot be reproduced except in full, without prior written approval of the Company. Any unauthorized alteration, forgery or falsification of the content or appearance of this document is unlawful and offenders may be prosecuted to the fullest extent of the law.

Report Number :E2/2022/20116
 Operation Mode :LTE B4
 Test Mode :TX CH MID
 EUT Pol :E2 Plane
 Test Frequency :1732.5 MHz

Test Site :SAC D
 Test Date :2022-03-22
 Temp./Humi. :20.3/70
 Antenna Pol. :Horizontal
 Engineer :Jack Tseng

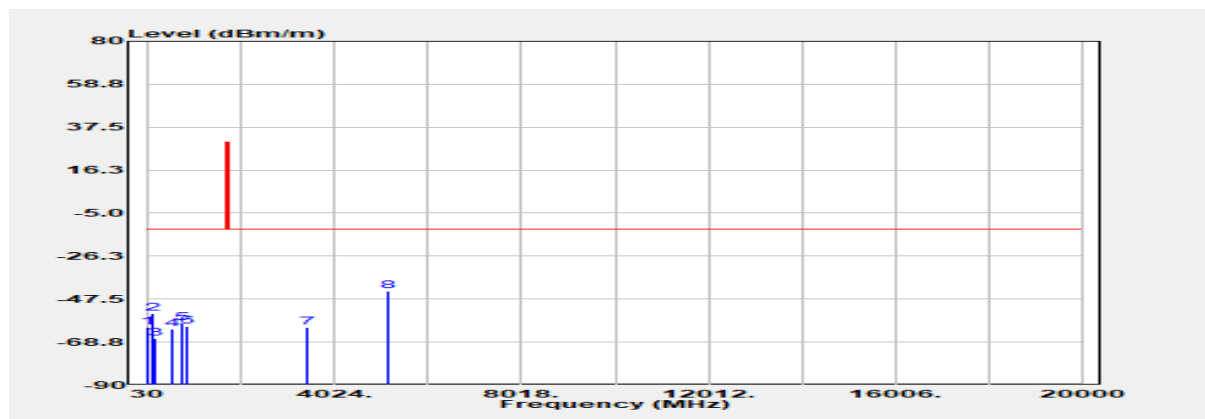

Freq. MHz	EIRP/ERP dBm	SG Output Level dBm	Antenna Gain dBi/dBd	Cable Loss dB	Limit dBm	Margin dB
31.940	-61.31	-41.43	-19.56	-0.32	-13.00	-48.31
177.440	-54.50	-49.5	-4.21	-0.79	-13.00	-41.50
230.790	-66.80	-65.91	0.01	-0.90	-13.00	-53.80
592.600	-62.35	-59.77	-1.14	-1.44	-13.00	-49.35
774.960	-59.14	-56.2	-1.55	-1.39	-13.00	-46.14
865.170	-61.08	-58.3	-1.20	-1.58	-13.00	-48.08
3465.000	-61.48	-70.26	12.47	-3.69	-13.00	-48.48
5197.500	-43.70	-51.59	12.39	-4.50	-13.00	-30.70

Unless otherwise stated the results shown in this test report refer only to the sample(s) tested and such sample(s) are retained for 90 days only.

除非另有說明，此報告結果僅對測試之樣品負責，同時此樣品僅保留90天。本報告未經本公司書面許可，不可部份複製。
 This document is issued by the Company subject to its General Conditions of Service printed overleaf, available on request or accessible at <http://www.sgs.com.tw/Terms-and-Conditions> and for electronic format documents, subject to Terms and Conditions for Electronic Documents at <http://www.sgs.com.tw/Terms-and-Conditions>. Attention is drawn to the limitation of liability, indemnification and jurisdiction issues defined therein. Any holder of this document is advised that information contained hereon reflects the Company's findings at the time of its intervention only and within the limits of Client's instructions, if any. The Company's sole responsibility is to its Client and this document does not exonerate parties to a transaction from exercising all their rights and obligations under the transaction documents. This document cannot be reproduced except in full, without prior written approval of the Company. Any unauthorized alteration, forgery or falsification of the content or appearance of this document is unlawful and offenders may be prosecuted to the fullest extent of the law.

Report Number :E2/2022/20116
 Operation Mode :LTE B4
 Test Mode :TX CH HIGH
 EUT Pol :E2 Plane
 Test Frequency :1747.5 MHz

Test Site :SAC D
 Test Date :2022-03-22
 Temp./Humi. :20.3/70
 Antenna Pol. :Vertical
 Engineer :Jack Tseng

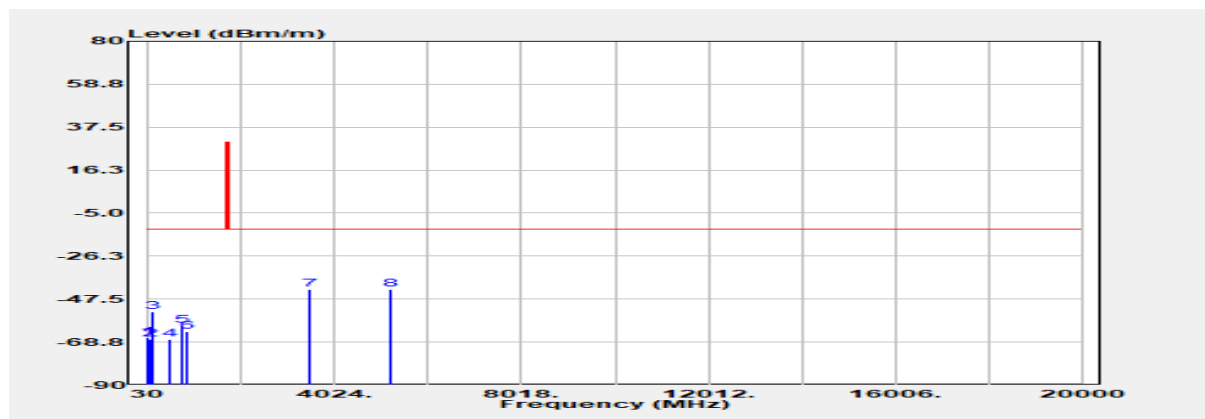

Freq. MHz	EIRP/ERP dBm	SG Output Level dBm	Antenna Gain dBi/dBd	Cable Loss dB	Limit dBm	Margin dB
60.070	-66.52	-51.3	-14.77	-0.45	-13.00	-53.52
107.600	-67.43	-60.53	-6.30	-0.60	-13.00	-54.43
178.410	-53.70	-48.84	-4.07	-0.79	-13.00	-40.70
505.300	-67.30	-65.14	-0.77	-1.39	-13.00	-54.30
774.960	-60.77	-57.83	-1.55	-1.39	-13.00	-47.77
863.230	-63.59	-60.8	-1.22	-1.57	-13.00	-50.59
3495.000	-42.55	-51.36	12.41	-3.60	-13.00	-29.55
5242.500	-42.73	-51	12.74	-4.47	-13.00	-29.73

Unless otherwise stated the results shown in this test report refer only to the sample(s) tested and such sample(s) are retained for 90 days only.

除非另有說明，此報告結果僅對測試之樣品負責，同時此樣品僅保留90天。本報告未經本公司書面許可，不可部份複製。

This document is issued by the Company subject to its General Conditions of Service printed overleaf, available on request or accessible at <http://www.sgs.com.tw/Terms-and-Conditions> and for electronic format documents, subject to Terms and Conditions for Electronic Documents at <http://www.sgs.com.tw/Terms-and-Conditions>. Attention is drawn to the limitation of liability, indemnification and jurisdiction issues defined therein. Any holder of this document is advised that information contained hereon reflects the Company's findings at the time of its intervention only and within the limits of Client's instructions, if any. The Company's sole responsibility is to its Client and this document does not exonerate parties to a transaction from exercising all their rights and obligations under the transaction documents. This document cannot be reproduced except in full, without prior written approval of the Company. Any unauthorized alteration, forgery or falsification of the content or appearance of this document is unlawful and offenders may be prosecuted to the fullest extent of the law.

Report Number :E2/2022/20116
 Operation Mode :LTE B4
 Test Mode :TX CH HIGH
 EUT Pol :E2 Plane
 Test Frequency :1747.5 MHz

Test Site :SAC D
 Test Date :2022-03-22
 Temp./Humi. :20.3/70
 Antenna Pol. :Horizontal
 Engineer :Jack Tseng

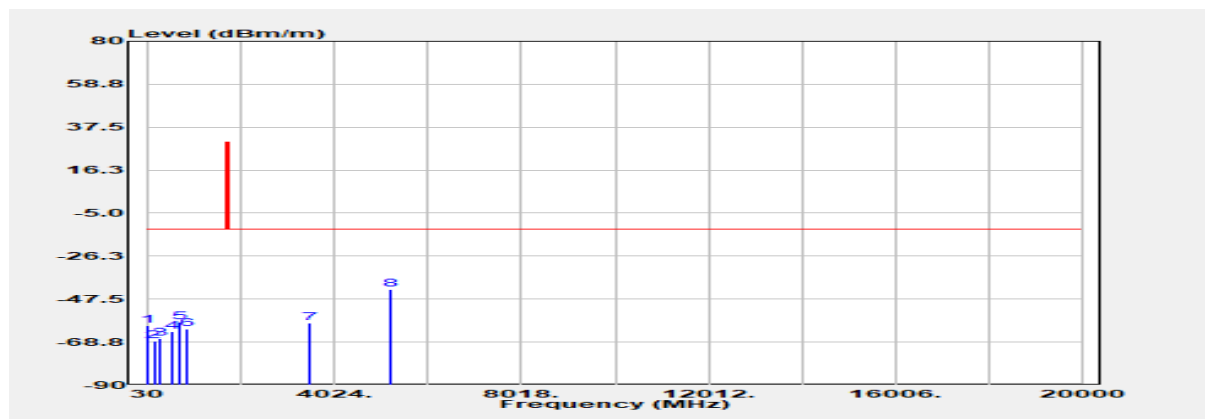

Freq. MHz	EIRP/ERP dBm	SG Output Level dBm	Antenna Gain dBi/dBd	Cable Loss dB	Limit dBm	Margin dB
31.940	-60.70	-40.82	-19.56	-0.32	-13.00	-47.70
180.350	-68.16	-63.61	-3.75	-0.80	-13.00	-55.16
296.750	-66.99	-64.91	-1.03	-1.05	-13.00	-53.99
593.570	-63.42	-60.87	-1.14	-1.41	-13.00	-50.42
740.040	-58.90	-55.62	-1.36	-1.92	-13.00	-45.90
866.140	-62.34	-59.56	-1.19	-1.59	-13.00	-49.34
3495.000	-59.13	-67.94	12.41	-3.60	-13.00	-46.13
5242.500	-42.68	-50.95	12.74	-4.47	-13.00	-29.68

Unless otherwise stated the results shown in this test report refer only to the sample(s) tested and such sample(s) are retained for 90 days only.

除非另有說明，此報告結果僅對測試之樣品負責，同時此樣品僅保留90天。本報告未經本公司書面許可，不可部份複製。

This document is issued by the Company subject to its General Conditions of Service printed overleaf, available on request or accessible at <http://www.sgs.com.tw/Terms-and-Conditions> and for electronic format documents, subject to Terms and Conditions for Electronic Documents at <http://www.sgs.com.tw/Terms-and-Conditions>. Attention is drawn to the limitation of liability, indemnification and jurisdiction issues defined therein. Any holder of this document is advised that information contained hereon reflects the Company's findings at the time of its intervention only and within the limits of Client's instructions, if any. The Company's sole responsibility is to its Client and this document does not exonerate parties to a transaction from exercising all their rights and obligations under the transaction documents. This document cannot be reproduced except in full, without prior written approval of the Company. Any unauthorized alteration, forgery or falsification of the content or appearance of this document is unlawful and offenders may be prosecuted to the fullest extent of the law.

Report Number :E2/2022/20116
 Operation Mode :LTE B5
 Test Mode :TX CH LOW
 EUT Pol :E2 Plane
 Test Frequency :829 MHz

Test Site :SAC D
 Test Date :2022-03-22
 Temp./Humi. :20.3/70
 Antenna Pol. :Vertical
 Engineer :Jack Tseng

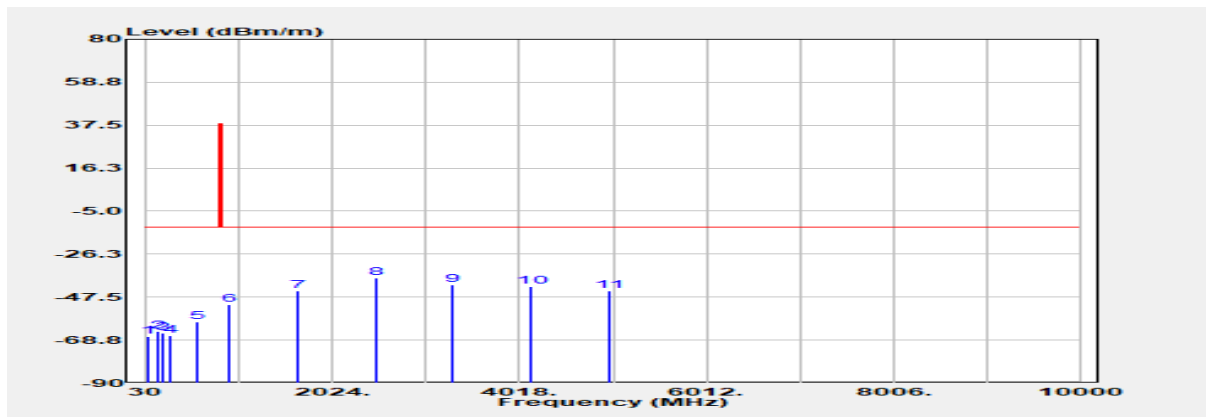

Freq. MHz	EIRP/ERP dBm	SG Output Level dBm	Antenna Gain dBi/dBd	Cable Loss dB	Limit dBm	Margin dB
59.100	-66.89	-51.62	-14.82	-0.45	-13.00	-53.89
182.290	-64.30	-60.2	-3.30	-0.80	-13.00	-51.30
220.120	-65.09	-64.23	0.02	-0.88	-13.00	-52.09
305.480	-66.75	-64.68	-0.96	-1.11	-13.00	-53.75
599.390	-59.62	-57.13	-1.26	-1.23	-13.00	-46.62
922.400	-51.03	-47.81	-1.39	-1.83	-13.00	-38.03
1658.000	-44.34	-51.35	9.52	-2.51	-13.00	-31.34
2487.000	-38.22	-45.75	10.57	-3.04	-13.00	-25.22
3316.000	-41.25	-50.16	12.50	-3.59	-13.00	-28.25
4145.000	-42.48	-50.83	12.40	-4.05	-13.00	-29.48
4974.000	-44.46	-52.54	12.50	-4.42	-13.00	-31.46

Unless otherwise stated the results shown in this test report refer only to the sample(s) tested and such sample(s) are retained for 90 days only.

除非另有說明，此報告結果僅對測試之樣品負責，同時此樣品僅保留90天。本報告未經本公司書面許可，不可部份複製。

This document is issued by the Company subject to its General Conditions of Service printed overleaf, available on request or accessible at <http://www.sgs.com.tw/Terms-and-Conditions> and for electronic format documents, subject to Terms and Conditions for Electronic Documents at <http://www.sgs.com.tw/Terms-and-Conditions>. Attention is drawn to the limitation of liability, indemnification and jurisdiction issues defined therein. Any holder of this document is advised that information contained hereon reflects the Company's findings at the time of its intervention only and within the limits of Client's instructions, if any. The Company's sole responsibility is to its Client and this document does not exonerate parties to a transaction from exercising all their rights and obligations under the transaction documents. This document cannot be reproduced except in full, without prior written approval of the Company. Any unauthorized alteration, forgery or falsification of the content or appearance of this document is unlawful and offenders may be prosecuted to the fullest extent of the law.

Report Number :E2/2022/20116
 Operation Mode :LTE B5
 Test Mode :TX CH LOW
 EUT Pol :E2 Plane
 Test Frequency :829 MHz

Test Site :SAC D
 Test Date :2022-03-22
 Temp./Humi. :20.3/70
 Antenna Pol. :Horizontal
 Engineer :Jack Tseng

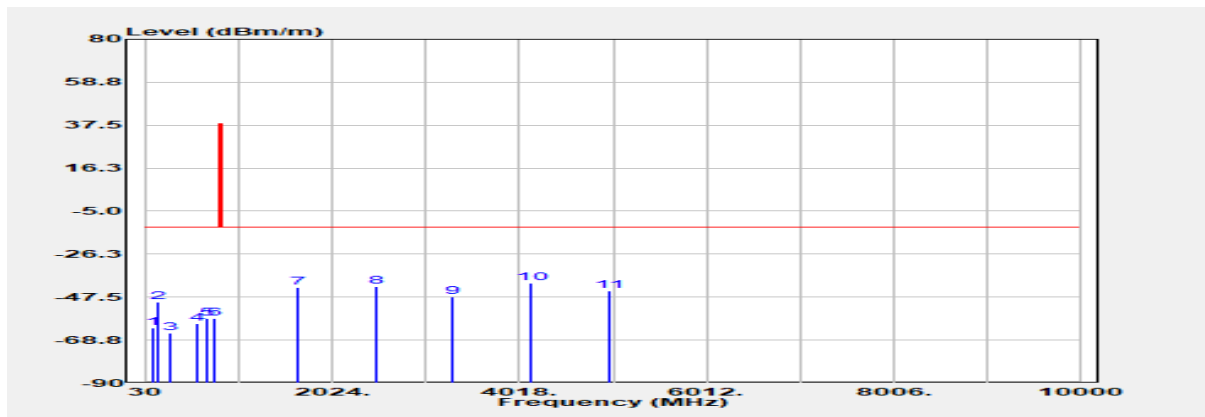

Freq. MHz	EIRP/ERP dBm	SG Output Level dBm	Antenna Gain dBi/dBd	Cable Loss dB	Limit dBm	Margin dB
109.540	-62.80	-55.73	-6.46	-0.61	-13.00	-49.80
179.380	-50.04	-45.32	-3.92	-0.80	-13.00	-37.04
296.750	-65.13	-63.05	-1.03	-1.05	-13.00	-52.13
592.600	-60.76	-58.18	-1.14	-1.44	-13.00	-47.76
680.870	-58.06	-55.71	-0.90	-1.45	-13.00	-45.06
778.840	-58.05	-55.08	-1.59	-1.38	-13.00	-45.05
1658.000	-42.65	-49.66	9.52	-2.51	-13.00	-29.65
2487.000	-42.19	-49.72	10.57	-3.04	-13.00	-29.19
3316.000	-47.32	-56.23	12.50	-3.59	-13.00	-34.32
4145.000	-40.49	-48.84	12.40	-4.05	-13.00	-27.49
4974.000	-44.53	-52.61	12.50	-4.42	-13.00	-31.53

Unless otherwise stated the results shown in this test report refer only to the sample(s) tested and such sample(s) are retained for 90 days only.

除非另有說明，此報告結果僅對測試之樣品負責，同時此樣品僅保留90天。本報告未經本公司書面許可，不可部份複製。

This document is issued by the Company subject to its General Conditions of Service printed overleaf, available on request or accessible at <http://www.sgs.com.tw/Terms-and-Conditions> and for electronic format documents, subject to Terms and Conditions for Electronic Documents at <http://www.sgs.com.tw/Terms-and-Conditions>. Attention is drawn to the limitation of liability, indemnification and jurisdiction issues defined therein. Any holder of this document is advised that information contained hereon reflects the Company's findings at the time of its intervention only and within the limits of Client's instructions, if any. The Company's sole responsibility is to its Client and this document does not exonerate parties to a transaction from exercising all their rights and obligations under the transaction documents. This document cannot be reproduced except in full, without prior written approval of the Company. Any unauthorized alteration, forgery or falsification of the content or appearance of this document is unlawful and offenders may be prosecuted to the fullest extent of the law.

Report Number :E2/2022/20116
 Operation Mode :LTE B5
 Test Mode :TX CH MID
 EUT Pol :E2 Plane
 Test Frequency :836.5 MHz

Test Site :SAC D
 Test Date :2022-03-22
 Temp./Humi. :20.3/70
 Antenna Pol. :Vertical
 Engineer :Jack Tseng

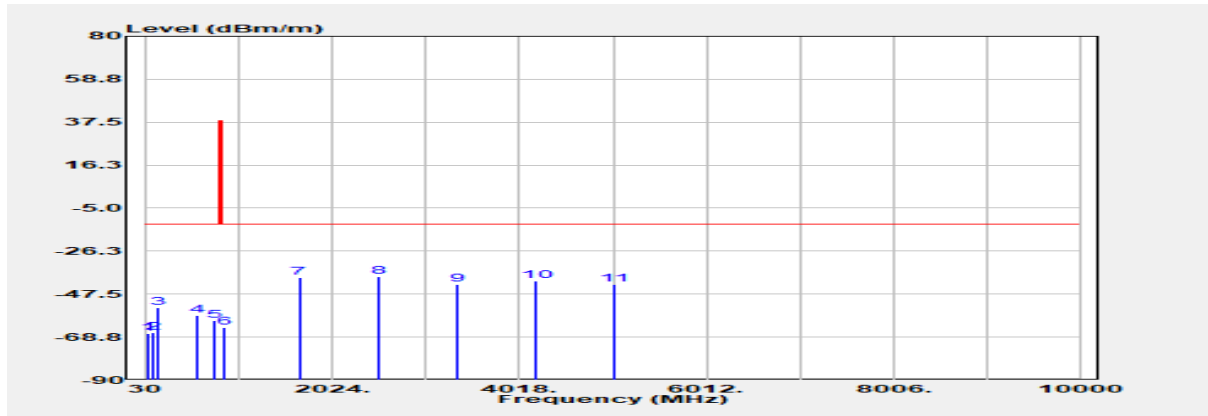

Freq. MHz	EIRP/ERP dBm	SG Output Level dBm	Antenna Gain dBi/dBd	Cable Loss dB	Limit dBm	Margin dB
60.070	-67.03	-51.81	-14.77	-0.45	-13.00	-54.03
109.540	-66.65	-59.58	-6.46	-0.61	-13.00	-53.65
179.380	-54.09	-49.37	-3.92	-0.80	-13.00	-41.09
590.660	-58.15	-55.53	-1.12	-1.50	-13.00	-45.15
773.990	-60.55	-57.62	-1.54	-1.39	-13.00	-47.55
875.840	-64.01	-61.14	-1.17	-1.70	-13.00	-51.01
1673.000	-39.41	-46.46	9.55	-2.50	-13.00	-26.41
2509.500	-38.67	-46.23	10.62	-3.06	-13.00	-25.67
3346.000	-42.81	-51.8	12.68	-3.69	-13.00	-29.81
4182.500	-41.20	-49.66	12.47	-4.01	-13.00	-28.20
5019.000	-42.91	-50.85	12.35	-4.41	-13.00	-29.91

Unless otherwise stated the results shown in this test report refer only to the sample(s) tested and such sample(s) are retained for 90 days only.

除非另有說明，此報告結果僅對測試之樣品負責，同時此樣品僅保留90天。本報告未經本公司書面許可，不可部份複製。

This document is issued by the Company subject to its General Conditions of Service printed overleaf, available on request or accessible at <http://www.sgs.com.tw/Terms-and-Conditions> and for electronic format documents, subject to Terms and Conditions for Electronic Documents at <http://www.sgs.com.tw/Terms-and-Conditions>. Attention is drawn to the limitation of liability, indemnification and jurisdiction issues defined therein. Any holder of this document is advised that information contained hereon reflects the Company's findings at the time of its intervention only and within the limits of Client's instructions, if any. The Company's sole responsibility is to its Client and this document does not exonerate parties to a transaction from exercising all their rights and obligations under the transaction documents. This document cannot be reproduced except in full, without prior written approval of the Company. Any unauthorized alteration, forgery or falsification of the content or appearance of this document is unlawful and offenders may be prosecuted to the fullest extent of the law.

Report Number :E2/2022/20116
 Operation Mode :LTE B5
 Test Mode :TX CH MID
 EUT Pol :E2 Plane
 Test Frequency :836.5 MHz

Test Site :SAC D
 Test Date :2022-03-22
 Temp./Humi. :20.3/70
 Antenna Pol. :Horizontal
 Engineer :Jack Tseng

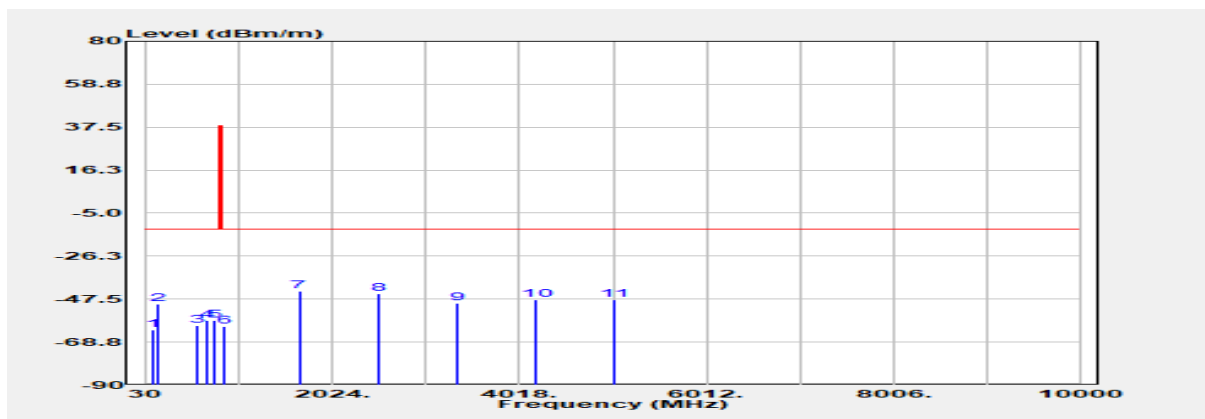

Freq. MHz	EIRP/ERP dBm	SG Output Level dBm	Antenna Gain dBi/dBd	Cable Loss dB	Limit dBm	Margin dB
109.540	-62.80	-55.73	-6.46	-0.61	-13.00	-49.80
179.380	-50.04	-45.32	-3.92	-0.80	-13.00	-37.04
592.600	-60.76	-58.18	-1.14	-1.44	-13.00	-47.76
680.870	-58.06	-55.71	-0.90	-1.45	-13.00	-45.06
778.840	-58.05	-55.08	-1.59	-1.38	-13.00	-45.05
869.050	-61.10	-58.33	-1.16	-1.61	-13.00	-48.10
1673.000	-43.51	-50.56	9.55	-2.50	-13.00	-30.51
2509.500	-44.84	-52.4	10.62	-3.06	-13.00	-31.84
3346.000	-49.72	-58.71	12.68	-3.69	-13.00	-36.72
4182.500	-48.00	-56.46	12.47	-4.01	-13.00	-35.00
5019.000	-47.70	-55.64	12.35	-4.41	-13.00	-34.70

Unless otherwise stated the results shown in this test report refer only to the sample(s) tested and such sample(s) are retained for 90 days only.

除非另有說明，此報告結果僅對測試之樣品負責，同時此樣品僅保留90天。本報告未經本公司書面許可，不可部份複製。

This document is issued by the Company subject to its General Conditions of Service printed overleaf, available on request or accessible at <http://www.sgs.com.tw/Terms-and-Conditions> and for electronic format documents, subject to Terms and Conditions for Electronic Documents at <http://www.sgs.com.tw/Terms-and-Conditions>. Attention is drawn to the limitation of liability, indemnification and jurisdiction issues defined therein. Any holder of this document is advised that information contained hereon reflects the Company's findings at the time of its intervention only and within the limits of Client's instructions, if any. The Company's sole responsibility is to its Client and this document does not exonerate parties to a transaction from exercising all their rights and obligations under the transaction documents. This document cannot be reproduced except in full, without prior written approval of the Company. Any unauthorized alteration, forgery or falsification of the content or appearance of this document is unlawful and offenders may be prosecuted to the fullest extent of the law.

Report Number :E2/2022/20116
 Operation Mode :LTE B5
 Test Mode :TX CH HIGH
 EUT Pol :E2 Plane
 Test Frequency :844 MHz

Test Site :SAC D
 Test Date :2022-03-22
 Temp./Humi. :20.3/70
 Antenna Pol. :Vertical
 Engineer :Jack Tseng

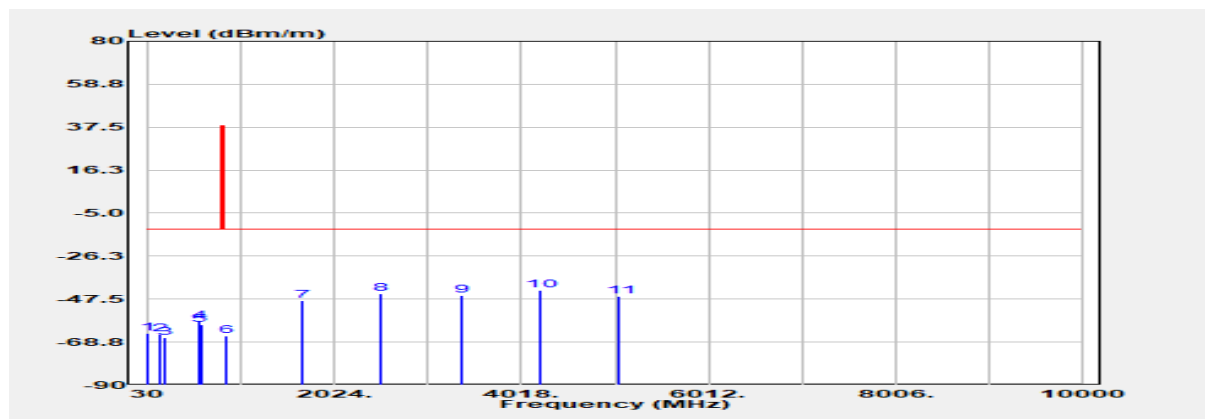

Freq. MHz	EIRP/ERP dBm	SG Output Level dBm	Antenna Gain dBi/dBd	Cable Loss dB	Limit dBm	Margin dB
30.970	-64.33	-44.09	-19.92	-0.32	-13.00	-51.33
181.320	-64.77	-60.46	-3.51	-0.80	-13.00	-51.77
228.850	-66.70	-65.94	0.14	-0.90	-13.00	-53.70
592.600	-58.67	-56.09	-1.14	-1.44	-13.00	-45.67
601.330	-60.33	-57.82	-1.31	-1.20	-13.00	-47.33
865.170	-65.79	-63.01	-1.20	-1.58	-13.00	-52.79
1688.000	-48.29	-55.38	9.58	-2.49	-13.00	-35.29
2532.000	-44.97	-52.56	10.66	-3.07	-13.00	-31.97
3376.000	-45.53	-54.59	12.65	-3.59	-13.00	-32.53
4220.000	-43.16	-51.6	12.46	-4.02	-13.00	-30.16
5064.000	-46.27	-53.94	12.10	-4.43	-13.00	-33.27

Unless otherwise stated the results shown in this test report refer only to the sample(s) tested and such sample(s) are retained for 90 days only.

除非另有說明，此報告結果僅對測試之樣品負責，同時此樣品僅保留90天。本報告未經本公司書面許可，不可部份複製。

This document is issued by the Company subject to its General Conditions of Service printed overleaf, available on request or accessible at <http://www.sgs.com.tw/Terms-and-Conditions> and for electronic format documents, subject to Terms and Conditions for Electronic Documents at <http://www.sgs.com.tw/Terms-and-Conditions>. Attention is drawn to the limitation of liability, indemnification and jurisdiction issues defined therein. Any holder of this document is advised that information contained hereon reflects the Company's findings at the time of its intervention only and within the limits of Client's instructions, if any. The Company's sole responsibility is to its Client and this document does not exonerate parties to a transaction from exercising all their rights and obligations under the transaction documents. This document cannot be reproduced except in full, without prior written approval of the Company. Any unauthorized alteration, forgery or falsification of the content or appearance of this document is unlawful and offenders may be prosecuted to the fullest extent of the law.

Report Number :E2/2022/20116
 Operation Mode :LTE B5
 Test Mode :TX CH HIGH
 EUT Pol :E2 Plane
 Test Frequency :844 MHz

Test Site :SAC D
 Test Date :2022-03-22
 Temp./Humi. :20.3/70
 Antenna Pol. :Horizontal
 Engineer :Jack Tseng

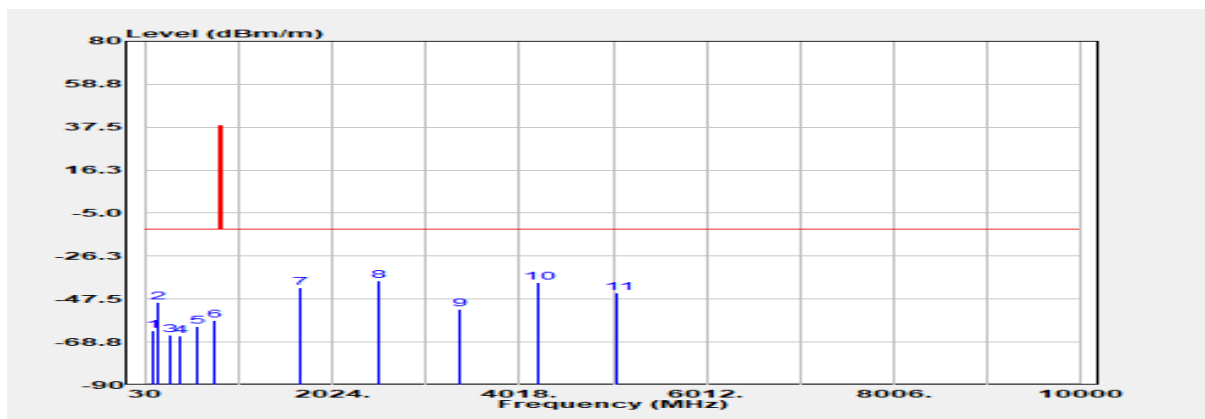

Freq. MHz	EIRP/ERP dBm	SG Output Level dBm	Antenna Gain dBi/dBd	Cable Loss dB	Limit dBm	Margin dB
107.600	-63.06	-56.16	-6.30	-0.60	-13.00	-50.06
178.410	-49.19	-44.33	-4.07	-0.79	-13.00	-36.19
297.720	-65.46	-63.38	-1.02	-1.06	-13.00	-52.46
405.390	-65.89	-63.8	-0.68	-1.41	-13.00	-52.89
592.600	-60.99	-58.41	-1.14	-1.44	-13.00	-47.99
778.840	-58.24	-55.27	-1.59	-1.38	-13.00	-45.24
1688.000	-41.93	-49.02	9.58	-2.49	-13.00	-28.93
2532.000	-38.55	-46.14	10.66	-3.07	-13.00	-25.55
3376.000	-52.61	-61.67	12.65	-3.59	-13.00	-39.61
4220.000	-39.39	-47.83	12.46	-4.02	-13.00	-26.39
5064.000	-44.49	-52.16	12.10	-4.43	-13.00	-31.49

Unless otherwise stated the results shown in this test report refer only to the sample(s) tested and such sample(s) are retained for 90 days only.

除非另有說明，此報告結果僅對測試之樣品負責，同時此樣品僅保留90天。本報告未經本公司書面許可，不可部份複製。

This document is issued by the Company subject to its General Conditions of Service printed overleaf, available on request or accessible at <http://www.sgs.com.tw/Terms-and-Conditions> and for electronic format documents, subject to Terms and Conditions for Electronic Documents at <http://www.sgs.com.tw/Terms-and-Conditions>. Attention is drawn to the limitation of liability, indemnification and jurisdiction issues defined therein. Any holder of this document is advised that information contained hereon reflects the Company's findings at the time of its intervention only and within the limits of Client's instructions, if any. The Company's sole responsibility is to its Client and this document does not exonerate parties to a transaction from exercising all their rights and obligations under the transaction documents. This document cannot be reproduced except in full, without prior written approval of the Company. Any unauthorized alteration, forgery or falsification of the content or appearance of this document is unlawful and offenders may be prosecuted to the fullest extent of the law.

Report Number :E2/2022/20116
 Operation Mode :LTE B12
 Test Mode :TX CH LOW
 EUT Pol :E2 Plane
 Test Frequency :700.5 MHz

Test Site :SAC D
 Test Date :2022-03-22
 Temp./Humi. :20.3/70
 Antenna Pol. :Vertical
 Engineer :Jack Tseng

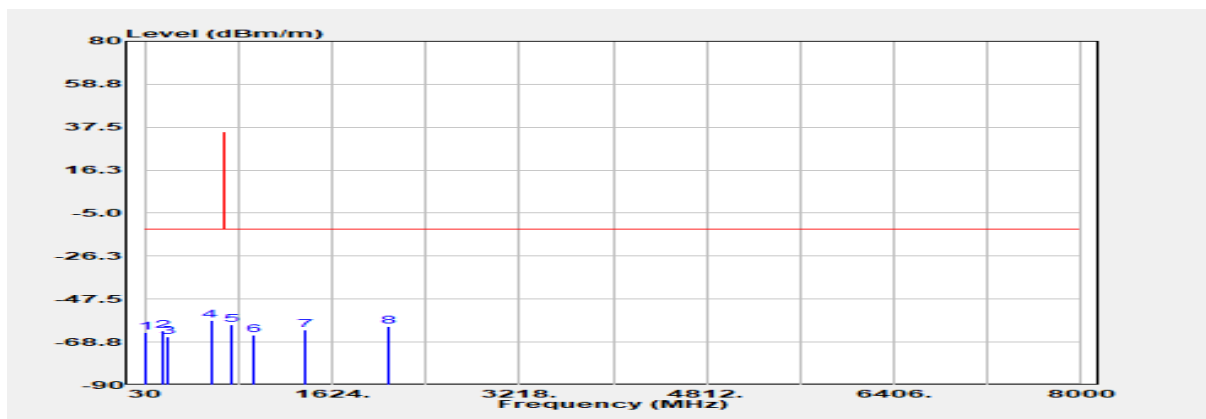

Freq. MHz	EIRP/ERP dBm	SG Output Level dBm	Antenna Gain dBi/dBd	Cable Loss dB	Limit dBm	Margin dB
31.940	-63.98	-44.1	-19.56	-0.32	-13.00	-50.98
182.290	-63.16	-59.06	-3.30	-0.80	-13.00	-50.16
226.910	-65.96	-65.29	0.22	-0.89	-13.00	-52.96
591.630	-58.22	-55.62	-1.13	-1.47	-13.00	-45.22
773.990	-60.18	-57.25	-1.54	-1.39	-13.00	-47.18
953.440	-65.16	-61.99	-1.36	-1.81	-13.00	-52.16
1401.000	-62.93	-68.27	7.61	-2.27	-13.00	-49.93
2101.500	-61.17	-68.26	9.88	-2.79	-13.00	-48.17

Unless otherwise stated the results shown in this test report refer only to the sample(s) tested and such sample(s) are retained for 90 days only.

除非另有說明，此報告結果僅對測試之樣品負責，同時此樣品僅保留90天。本報告未經本公司書面許可，不可部份複製。

This document is issued by the Company subject to its General Conditions of Service printed overleaf, available on request or accessible at <http://www.sgs.com.tw/Terms-and-Conditions> and for electronic format documents, subject to Terms and Conditions for Electronic Documents at <http://www.sgs.com.tw/Terms-and-Conditions>. Attention is drawn to the limitation of liability, indemnification and jurisdiction issues defined therein. Any holder of this document is advised that information contained hereon reflects the Company's findings at the time of its intervention only and within the limits of Client's instructions, if any. The Company's sole responsibility is to its Client and this document does not exonerate parties to a transaction from exercising all their rights and obligations under the transaction documents. This document cannot be reproduced except in full, without prior written approval of the Company. Any unauthorized alteration, forgery or falsification of the content or appearance of this document is unlawful and offenders may be prosecuted to the fullest extent of the law.

Report Number :E2/2022/20116
 Operation Mode :LTE B12
 Test Mode :TX CH LOW
 EUT Pol :E2 Plane
 Test Frequency :700.5 MHz

Test Site :SAC D
 Test Date :2022-03-22
 Temp./Humi. :20.3/70
 Antenna Pol. :Horizontal
 Engineer :Jack Tseng

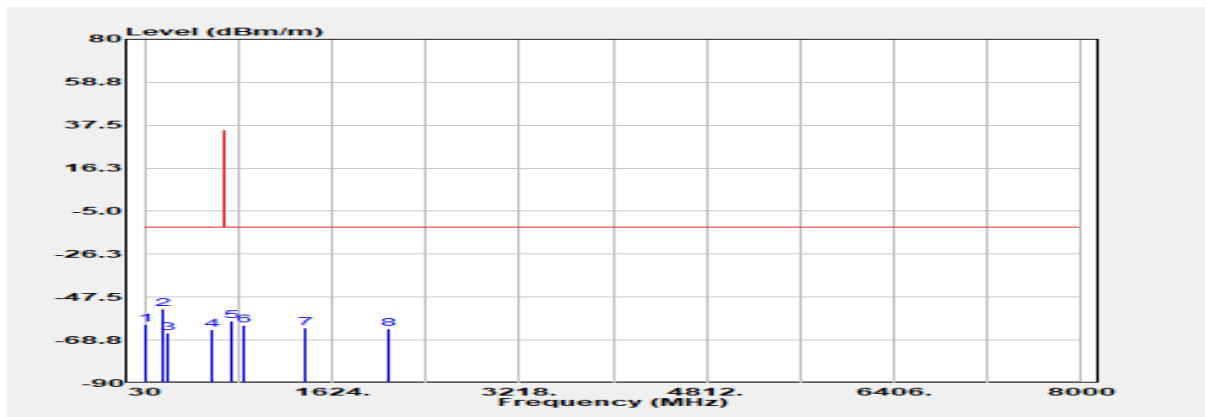

Freq. MHz	EIRP/ERP dBm	SG Output Level dBm	Antenna Gain dBi/dBd	Cable Loss dB	Limit dBm	Margin dB
31.940	-61.12	-41.24	-19.56	-0.32	-13.00	-48.12
177.440	-53.49	-48.49	-4.21	-0.79	-13.00	-40.49
226.910	-65.08	-64.41	0.22	-0.89	-13.00	-52.08
597.450	-63.62	-61.12	-1.21	-1.29	-13.00	-50.62
774.960	-59.42	-56.48	-1.55	-1.39	-13.00	-46.42
870.990	-61.65	-58.86	-1.16	-1.63	-13.00	-48.65
1401.000	-62.62	-67.96	7.61	-2.27	-13.00	-49.62
2101.500	-63.12	-70.21	9.88	-2.79	-13.00	-50.12

Unless otherwise stated the results shown in this test report refer only to the sample(s) tested and such sample(s) are retained for 90 days only.

除非另有說明，此報告結果僅對測試之樣品負責，同時此樣品僅保留90天。本報告未經本公司書面許可，不可部份複製。

This document is issued by the Company subject to its General Conditions of Service printed overleaf, available on request or accessible at <http://www.sgs.com.tw/Terms-and-Conditions> and for electronic format documents, subject to Terms and Conditions for Electronic Documents at <http://www.sgs.com.tw/Terms-and-Conditions>. Attention is drawn to the limitation of liability, indemnification and jurisdiction issues defined therein. Any holder of this document is advised that information contained hereon reflects the Company's findings at the time of its intervention only and within the limits of Client's instructions, if any. The Company's sole responsibility is to its Client and this document does not exonerate parties to a transaction from exercising all their rights and obligations under the transaction documents. This document cannot be reproduced except in full, without prior written approval of the Company. Any unauthorized alteration, forgery or falsification of the content or appearance of this document is unlawful and offenders may be prosecuted to the fullest extent of the law.

Report Number :E2/2022/20116
 Operation Mode :LTE B12
 Test Mode :TX CH MID
 EUT Pol :E2 Plane
 Test Frequency :707.5 MHz

Test Site :SAC D
 Test Date :2022-03-22
 Temp./Humi. :20.3/70
 Antenna Pol. :Vertical
 Engineer :Jack Tseng

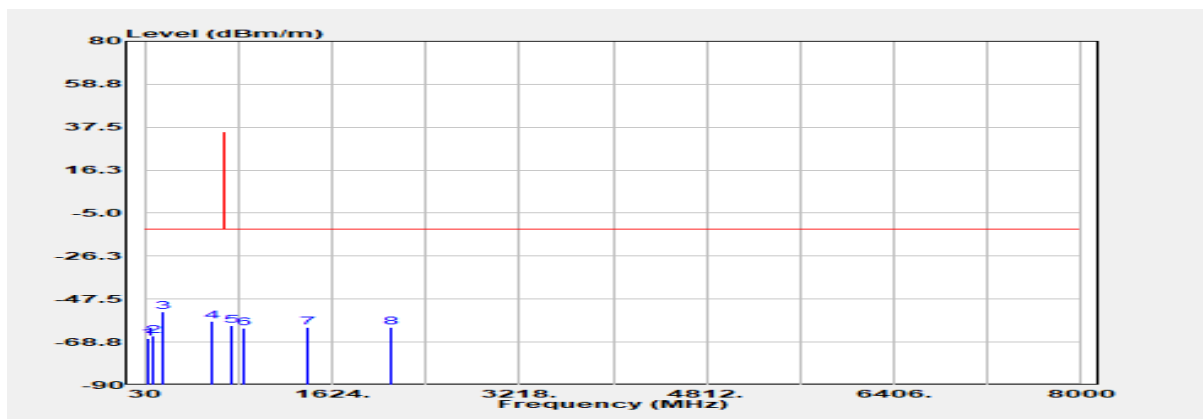

Freq. MHz	EIRP/ERP dBm	SG Output Level dBm	Antenna Gain dBi/dBd	Cable Loss dB	Limit dBm	Margin dB
61.040	-67.14	-52.08	-14.61	-0.45	-13.00	-54.14
110.510	-65.90	-58.82	-6.47	-0.61	-13.00	-52.90
180.350	-53.92	-49.37	-3.75	-0.80	-13.00	-40.92
594.540	-58.42	-55.89	-1.15	-1.38	-13.00	-45.42
774.960	-60.60	-57.66	-1.55	-1.39	-13.00	-47.60
866.140	-61.77	-58.99	-1.19	-1.59	-13.00	-48.77
1415.000	-61.45	-66.89	7.72	-2.28	-13.00	-48.45
2122.500	-61.64	-68.47	9.63	-2.80	-13.00	-48.64

Unless otherwise stated the results shown in this test report refer only to the sample(s) tested and such sample(s) are retained for 90 days only.

除非另有說明，此報告結果僅對測試之樣品負責，同時此樣品僅保留90天。本報告未經本公司書面許可，不可部份複製。

This document is issued by the Company subject to its General Conditions of Service printed overleaf, available on request or accessible at <http://www.sgs.com.tw/Terms-and-Conditions> and for electronic format documents, subject to Terms and Conditions for Electronic Documents at <http://www.sgs.com.tw/Terms-and-Conditions>. Attention is drawn to the limitation of liability, indemnification and jurisdiction issues defined therein. Any holder of this document is advised that information contained hereon reflects the Company's findings at the time of its intervention only and within the limits of Client's instructions, if any. The Company's sole responsibility is to its Client and this document does not exonerate parties to a transaction from exercising all their rights and obligations under the transaction documents. This document cannot be reproduced except in full, without prior written approval of the Company. Any unauthorized alteration, forgery or falsification of the content or appearance of this document is unlawful and offenders may be prosecuted to the fullest extent of the law.

Report Number :E2/2022/20116
 Operation Mode :LTE B12
 Test Mode :TX CH MID
 EUT Pol :E2 Plane
 Test Frequency :707.5 MHz

Test Site :SAC D
 Test Date :2022-03-22
 Temp./Humi. :20.3/70
 Antenna Pol. :Horizontal
 Engineer :Jack Tseng

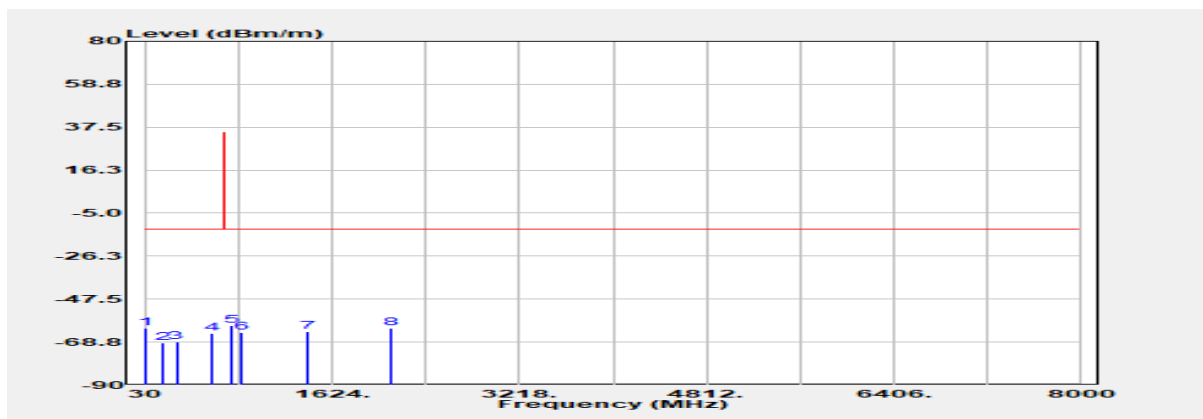

Freq. MHz	EIRP/ERP dBm	SG Output Level dBm	Antenna Gain dBi/dBd	Cable Loss dB	Limit dBm	Margin dB
31.940	-61.85	-41.97	-19.56	-0.32	-13.00	-48.85
181.320	-69.12	-64.81	-3.51	-0.80	-13.00	-56.12
298.690	-68.56	-66.49	-1.01	-1.06	-13.00	-55.56
595.510	-64.28	-61.77	-1.16	-1.35	-13.00	-51.28
777.870	-60.73	-57.77	-1.58	-1.38	-13.00	-47.73
859.350	-64.05	-61.27	-1.24	-1.54	-13.00	-51.05
1415.000	-63.65	-69.09	7.72	-2.28	-13.00	-50.65
2122.500	-61.67	-68.5	9.63	-2.80	-13.00	-48.67

Unless otherwise stated the results shown in this test report refer only to the sample(s) tested and such sample(s) are retained for 90 days only.

除非另有說明，此報告結果僅對測試之樣品負責，同時此樣品僅保留90天。本報告未經本公司書面許可，不可部份複製。

This document is issued by the Company subject to its General Conditions of Service printed overleaf, available on request or accessible at <http://www.sgs.com.tw/Terms-and-Conditions> and for electronic format documents, subject to Terms and Conditions for Electronic Documents at <http://www.sgs.com.tw/Terms-and-Conditions>. Attention is drawn to the limitation of liability, indemnification and jurisdiction issues defined therein. Any holder of this document is advised that information contained hereon reflects the Company's findings at the time of its intervention only and within the limits of Client's instructions, if any. The Company's sole responsibility is to its Client and this document does not exonerate parties to a transaction from exercising all their rights and obligations under the transaction documents. This document cannot be reproduced except in full, without prior written approval of the Company. Any unauthorized alteration, forgery or falsification of the content or appearance of this document is unlawful and offenders may be prosecuted to the fullest extent of the law.

Report Number :E2/2022/20116
 Operation Mode :LTE B12
 Test Mode :TX CH HIGH
 EUT Pol :E2 Plane
 Test Frequency :714.5 MHz

Test Site :SAC D
 Test Date :2022-03-22
 Temp./Humi. :20.3/70
 Antenna Pol. :Vertical
 Engineer :Jack Tseng

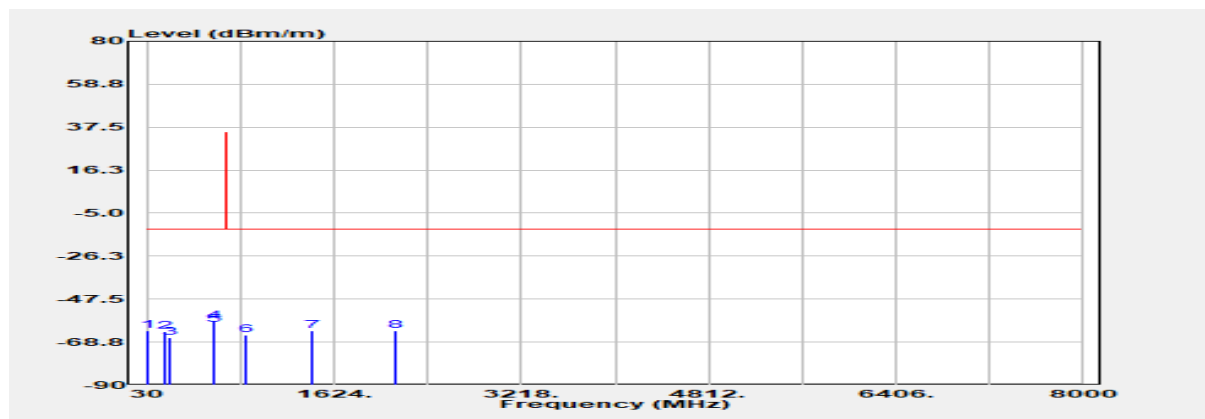

Freq. MHz	EIRP/ERP dBm	SG Output Level dBm	Antenna Gain dBi/dBd	Cable Loss dB	Limit dBm	Margin dB
30.970	-63.26	-43.02	-19.92	-0.32	-13.00	-50.26
182.290	-63.52	-59.42	-3.30	-0.80	-13.00	-50.52
227.880	-66.58	-65.86	0.18	-0.90	-13.00	-53.58
592.600	-58.42	-55.84	-1.14	-1.44	-13.00	-45.42
601.330	-60.29	-57.78	-1.31	-1.20	-13.00	-47.29
865.170	-65.17	-62.39	-1.20	-1.58	-13.00	-52.17
1429.000	-63.29	-68.83	7.83	-2.29	-13.00	-50.29
2143.500	-62.96	-69.53	9.38	-2.81	-13.00	-49.96

Unless otherwise stated the results shown in this test report refer only to the sample(s) tested and such sample(s) are retained for 90 days only.

除非另有說明，此報告結果僅對測試之樣品負責，同時此樣品僅保留90天。本報告未經本公司書面許可，不可部份複製。

This document is issued by the Company subject to its General Conditions of Service printed overleaf, available on request or accessible at <http://www.sgs.com.tw/Terms-and-Conditions> and for electronic format documents, subject to Terms and Conditions for Electronic Documents at <http://www.sgs.com.tw/Terms-and-Conditions>. Attention is drawn to the limitation of liability, indemnification and jurisdiction issues defined therein. Any holder of this document is advised that information contained hereon reflects the Company's findings at the time of its intervention only and within the limits of Client's instructions, if any. The Company's sole responsibility is to its Client and this document does not exonerate parties to a transaction from exercising all their rights and obligations under the transaction documents. This document cannot be reproduced except in full, without prior written approval of the Company. Any unauthorized alteration, forgery or falsification of the content or appearance of this document is unlawful and offenders may be prosecuted to the fullest extent of the law.

Report Number :E2/2022/20116
 Operation Mode :LTE B12
 Test Mode :TX CH HIGH
 EUT Pol :E2 Plane
 Test Frequency :714.5 MHz

Test Site :SAC D
 Test Date :2022-03-22
 Temp./Humi. :20.3/70
 Antenna Pol. :Horizontal
 Engineer :Jack Tseng

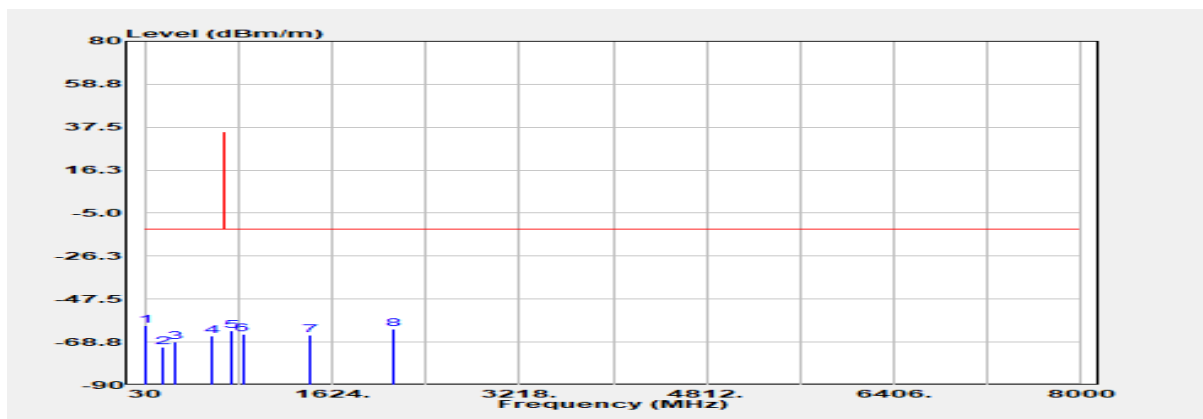

Freq. MHz	EIRP/ERP dBm	SG Output Level dBm	Antenna Gain dBi/dBd	Cable Loss dB	Limit dBm	Margin dB
31.940	-60.79	-40.91	-19.56	-0.32	-13.00	-47.79
180.350	-71.15	-66.6	-3.75	-0.80	-13.00	-58.15
295.780	-68.69	-66.61	-1.03	-1.05	-13.00	-55.69
592.600	-65.82	-63.24	-1.14	-1.44	-13.00	-52.82
774.960	-62.98	-60.04	-1.55	-1.39	-13.00	-49.98
863.230	-64.72	-61.93	-1.22	-1.57	-13.00	-51.72
1429.000	-65.21	-70.75	7.83	-2.29	-13.00	-52.21
2143.500	-62.34	-68.91	9.38	-2.81	-13.00	-49.34

Unless otherwise stated the results shown in this test report refer only to the sample(s) tested and such sample(s) are retained for 90 days only.

除非另有說明，此報告結果僅對測試之樣品負責，同時此樣品僅保留90天。本報告未經本公司書面許可，不可部份複製。
 This document is issued by the Company subject to its General Conditions of Service printed overleaf, available on request or accessible at <http://www.sgs.com.tw/Terms-and-Conditions> and for electronic format documents, subject to Terms and Conditions for Electronic Documents at <http://www.sgs.com.tw/Terms-and-Conditions>. Attention is drawn to the limitation of liability, indemnification and jurisdiction issues defined therein. Any holder of this document is advised that information contained hereon reflects the Company's findings at the time of its intervention only and within the limits of Client's instructions, if any. The Company's sole responsibility is to its Client and this document does not exonerate parties to a transaction from exercising all their rights and obligations under the transaction documents. This document cannot be reproduced except in full, without prior written approval of the Company. Any unauthorized alteration, forgery or falsification of the content or appearance of this document is unlawful and offenders may be prosecuted to the fullest extent of the law.

Report Number :E2/2022/20116

Test Site :SAC D

Operation Mode :LTE B13

Test Date :2022-03-22

Test Mode :TX CH LOW

Temp./Humi. :20.3/70

EUT Pol :E2 Plane

Antenna Pol. :Vertical

Test Frequency :779.5 MHz

Engineer :Jack Tseng

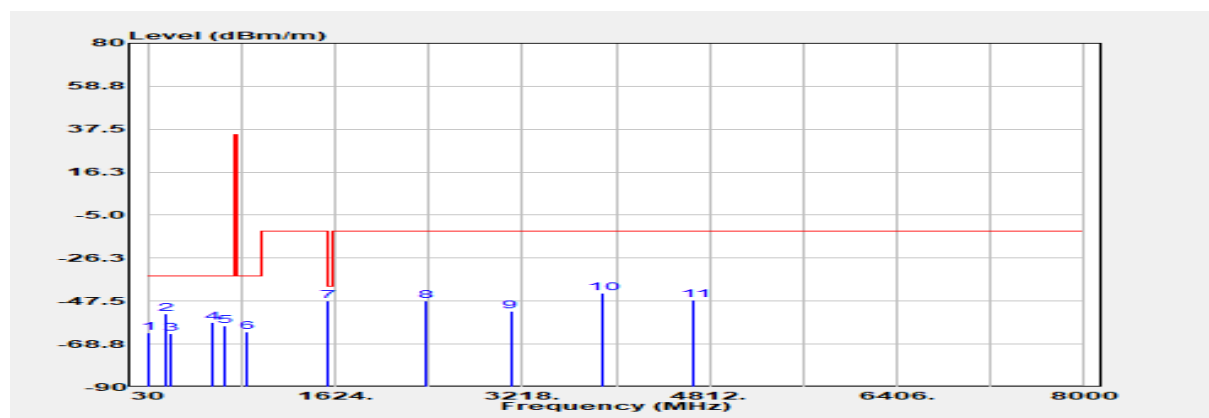

Freq. MHz	EIRP/ERP dBm	SG Output Level dBm	Antenna Gain dBi/dBd	Cable Loss dB	Limit dBm	Margin dB
31.940	-63.23	-43.35	-19.56	-0.32	-35.00	-28.23
179.380	-53.61	-48.89	-3.92	-0.80	-35.00	-18.61
225.940	-63.64	-63.01	0.26	-0.89	-35.00	-28.64
590.660	-58.16	-55.54	-1.12	-1.50	-35.00	-23.16
678.930	-59.88	-57.48	-0.90	-1.50	-35.00	-24.88
870.990	-62.56	-59.77	-1.16	-1.63	-35.00	-27.56
1559.000	-47.45	-54.19	9.15	-2.41	-40.00	-7.45
2388.500	-47.19	-54.19	9.99	-2.99	-13.00	-34.19
3118.000	-52.65	-60.61	11.36	-3.40	-13.00	-39.65
3897.500	-43.48	-52.04	12.40	-3.84	-13.00	-30.48
4677.000	-47.18	-55.23	12.30	-4.25	-13.00	-34.18

Unless otherwise stated the results shown in this test report refer only to the sample(s) tested and such sample(s) are retained for 90 days only.

除非另有說明，此報告結果僅對測試之樣品負責，同時此樣品僅保留90天。本報告未經本公司書面許可，不可部份複製。

This document is issued by the Company subject to its General Conditions of Service printed overleaf, available on request or accessible at <http://www.sgs.com.tw/Terms-and-Conditions> and for electronic format documents, subject to Terms and Conditions for Electronic Documents at <http://www.sgs.com.tw/Terms-and-Conditions>. Attention is drawn to the limitation of liability, indemnification and jurisdiction issues defined therein. Any holder of this document is advised that information contained hereon reflects the Company's findings at the time of its intervention only and within the limits of Client's instructions, if any. The Company's sole responsibility is to its Client and this document does not exonerate parties to a transaction from exercising all their rights and obligations under the transaction documents. This document cannot be reproduced except in full, without prior written approval of the Company. Any unauthorized alteration, forgery or falsification of the content or appearance of this document is unlawful and offenders may be prosecuted to the fullest extent of the law.

Report Number :E2/2022/20116
 Operation Mode :LTE B13
 Test Mode :TX CH LOW
 EUT Pol :E2 Plane
 Test Frequency :779.5 MHz

Test Site :SAC D
 Test Date :2022-03-22
 Temp./Humi. :20.3/70
 Antenna Pol. :Horizontal
 Engineer :Jack Tseng

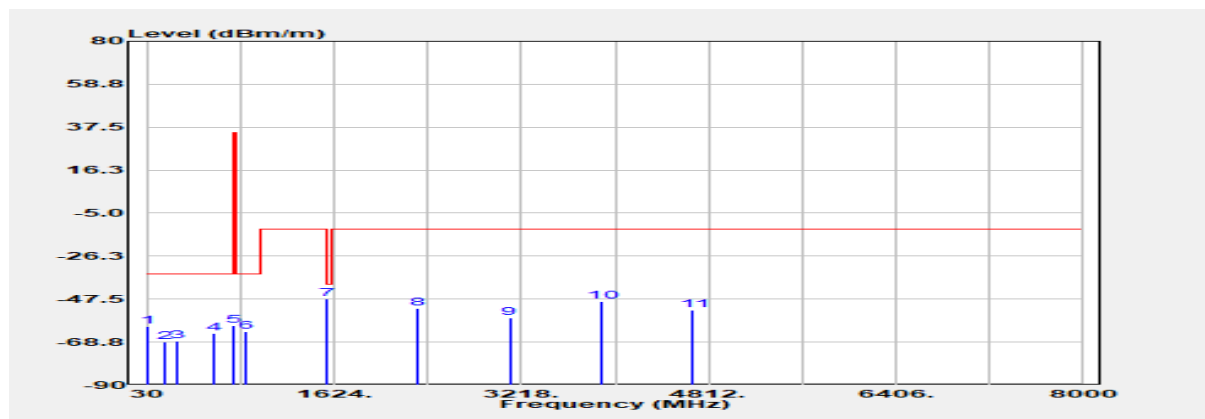

Freq. MHz	EIRP/ERP dBm	SG Output Level dBm	Antenna Gain dBi/dBd	Cable Loss dB	Limit dBm	Margin dB
31.940	-61.15	-41.27	-19.56	-0.32	-35.00	-26.15
179.380	-68.84	-64.12	-3.92	-0.80	-35.00	-33.84
292.870	-68.06	-66.01	-1.02	-1.03	-35.00	-33.06
592.600	-64.46	-61.88	-1.14	-1.44	-35.00	-29.46
774.960	-60.51	-57.57	-1.55	-1.39	-35.00	-25.51
866.140	-63.42	-60.64	-1.19	-1.59	-35.00	-28.42
1559.000	-47.59	-54.33	9.15	-2.41	-40.00	-7.59
2338.500	-52.07	-58.66	9.53	-2.94	-13.00	-39.07
3118.000	-56.73	-64.69	11.36	-3.40	-13.00	-43.73
3897.500	-48.58	-57.14	12.40	-3.84	-13.00	-35.58
4677.000	-52.81	-60.86	12.30	-4.25	-13.00	-39.81

Unless otherwise stated the results shown in this test report refer only to the sample(s) tested and such sample(s) are retained for 90 days only.

除非另有說明，此報告結果僅對測試之樣品負責，同時此樣品僅保留90天。本報告未經本公司書面許可，不可部份複製。

This document is issued by the Company subject to its General Conditions of Service printed overleaf, available on request or accessible at <http://www.sgs.com.tw/Terms-and-Conditions> and for electronic format documents, subject to Terms and Conditions for Electronic Documents at <http://www.sgs.com.tw/Terms-and-Conditions>. Attention is drawn to the limitation of liability, indemnification and jurisdiction issues defined therein. Any holder of this document is advised that information contained hereon reflects the Company's findings at the time of its intervention only and within the limits of Client's instructions, if any. The Company's sole responsibility is to its Client and this document does not exonerate parties to a transaction from exercising all their rights and obligations under the transaction documents. This document cannot be reproduced except in full, without prior written approval of the Company. Any unauthorized alteration, forgery or falsification of the content or appearance of this document is unlawful and offenders may be prosecuted to the fullest extent of the law.

Report Number :E2/2022/20116
 Operation Mode :LTE B13
 Test Mode :TX CH MID
 EUT Pol :E2 Plane
 Test Frequency :782 MHz

Test Site :SAC D
 Test Date :2022-03-22
 Temp./Humi. :20.3/70
 Antenna Pol. :Vertical
 Engineer :Jack Tseng

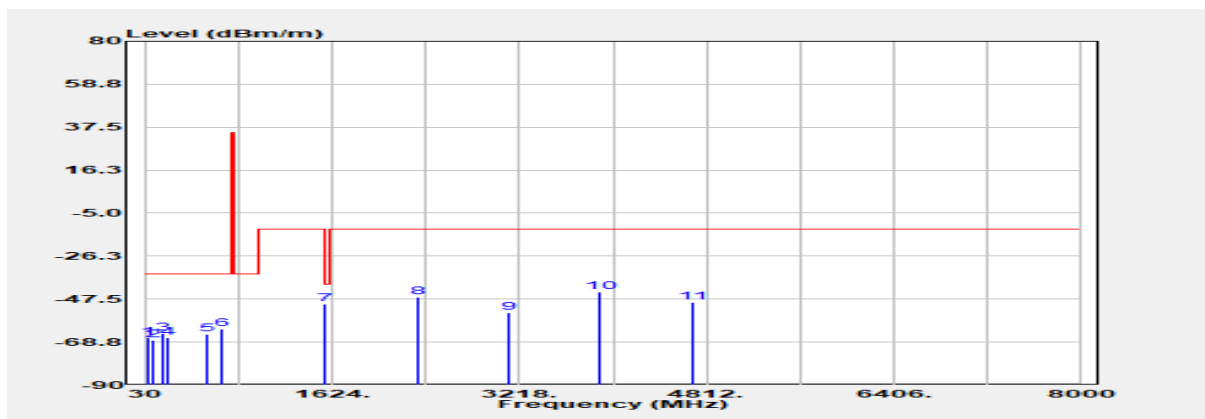

Freq. MHz	EIRP/ERP dBm	SG Output Level dBm	Antenna Gain dBi/dBd	Cable Loss dB	Limit dBm	Margin dB
60.070	-66.51	-51.29	-14.77	-0.45	-35.00	-31.51
107.600	-67.65	-60.75	-6.30	-0.60	-35.00	-32.65
180.350	-64.31	-59.76	-3.75	-0.80	-35.00	-29.31
227.880	-66.63	-65.91	0.18	-0.90	-35.00	-31.63
566.410	-64.76	-62.21	-0.81	-1.74	-35.00	-29.76
682.810	-62.37	-60.05	-0.91	-1.41	-35.00	-27.37
1564.000	-49.86	-56.63	9.18	-2.41	-40.00	-9.86
2346.000	-46.73	-53.37	9.58	-2.94	-13.00	-33.73
3128.000	-54.21	-62.18	11.34	-3.37	-13.00	-41.21
3910.000	-44.09	-52.62	12.38	-3.85	-13.00	-31.09
4692.000	-48.94	-56.99	12.30	-4.25	-13.00	-35.94

Unless otherwise stated the results shown in this test report refer only to the sample(s) tested and such sample(s) are retained for 90 days only.

除非另有說明，此報告結果僅對測試之樣品負責，同時此樣品僅保留90天。本報告未經本公司書面許可，不可部份複製。

This document is issued by the Company subject to its General Conditions of Service printed overleaf, available on request or accessible at <http://www.sgs.com.tw/Terms-and-Conditions> and for electronic format documents, subject to Terms and Conditions for Electronic Documents at <http://www.sgs.com.tw/Terms-and-Conditions>. Attention is drawn to the limitation of liability, indemnification and jurisdiction issues defined therein. Any holder of this document is advised that information contained hereon reflects the Company's findings at the time of its intervention only and within the limits of Client's instructions, if any. The Company's sole responsibility is to its Client and this document does not exonerate parties to a transaction from exercising all their rights and obligations under the transaction documents. This document cannot be reproduced except in full, without prior written approval of the Company. Any unauthorized alteration, forgery or falsification of the content or appearance of this document is unlawful and offenders may be prosecuted to the fullest extent of the law.

Report Number :E2/2022/20116
 Operation Mode :LTE B13
 Test Mode :TX CH MID
 EUT Pol :E2 Plane
 Test Frequency :782 MHz

Test Site :SAC D
 Test Date :2022-03-22
 Temp./Humi. :20.3/70
 Antenna Pol. :Horizontal
 Engineer :Jack Tseng

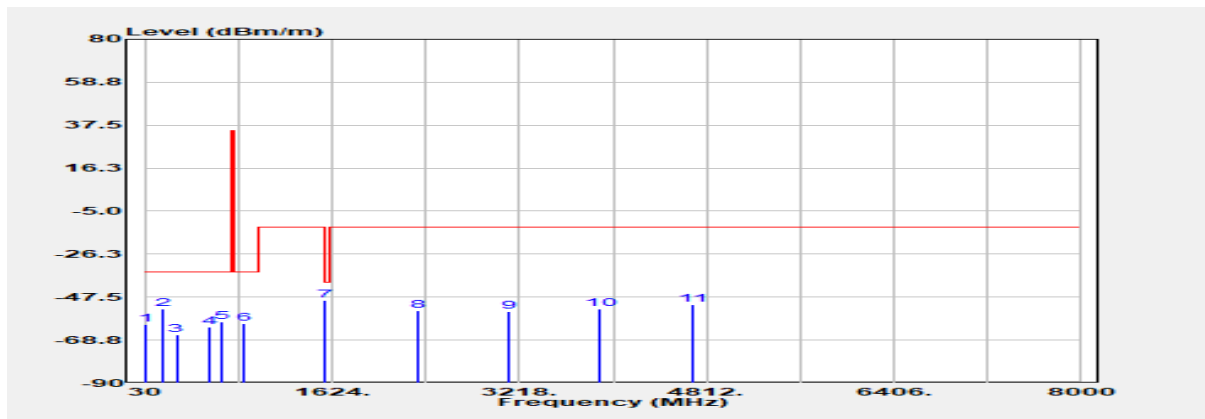

Freq. MHz	EIRP/ERP dBm	SG Output Level dBm	Antenna Gain dBi/dBd	Cable Loss dB	Limit dBm	Margin dB
31.940	-60.95	-41.07	-19.56	-0.32	-35.00	-25.95
178.410	-53.49	-48.63	-4.07	-0.79	-35.00	-18.49
298.690	-66.10	-64.03	-1.01	-1.06	-35.00	-31.10
590.660	-62.50	-59.88	-1.12	-1.50	-35.00	-27.50
683.780	-59.87	-57.56	-0.92	-1.39	-35.00	-24.87
865.170	-60.47	-57.69	-1.20	-1.58	-35.00	-25.47
1564.000	-49.12	-55.89	9.18	-2.41	-40.00	-9.12
2346.000	-54.42	-61.06	9.58	-2.94	-13.00	-41.42
3128.000	-54.57	-62.54	11.34	-3.37	-13.00	-41.57
3910.000	-53.43	-61.96	12.38	-3.85	-13.00	-40.43
4692.000	-51.32	-59.37	12.30	-4.25	-13.00	-38.32

Unless otherwise stated the results shown in this test report refer only to the sample(s) tested and such sample(s) are retained for 90 days only.

除非另有說明，此報告結果僅對測試之樣品負責，同時此樣品僅保留90天。本報告未經本公司書面許可，不可部份複製。

This document is issued by the Company subject to its General Conditions of Service printed overleaf, available on request or accessible at <http://www.sgs.com.tw/Terms-and-Conditions> and for electronic format documents, subject to Terms and Conditions for Electronic Documents at <http://www.sgs.com.tw/Terms-and-Conditions>. Attention is drawn to the limitation of liability, indemnification and jurisdiction issues defined therein. Any holder of this document is advised that information contained hereon reflects the Company's findings at the time of its intervention only and within the limits of Client's instructions, if any. The Company's sole responsibility is to its Client and this document does not exonerate parties to a transaction from exercising all their rights and obligations under the transaction documents. This document cannot be reproduced except in full, without prior written approval of the Company. Any unauthorized alteration, forgery or falsification of the content or appearance of this document is unlawful and offenders may be prosecuted to the fullest extent of the law.

Report Number :E2/2022/20116
 Operation Mode :LTE B13
 Test Mode :TX CH HIGH
 EUT Pol :E2 Plane
 Test Frequency :784.5 MHz

Test Site :SAC D
 Test Date :2022-03-22
 Temp./Humi. :20.3/70
 Antenna Pol. :Vertical
 Engineer :Jack Tseng

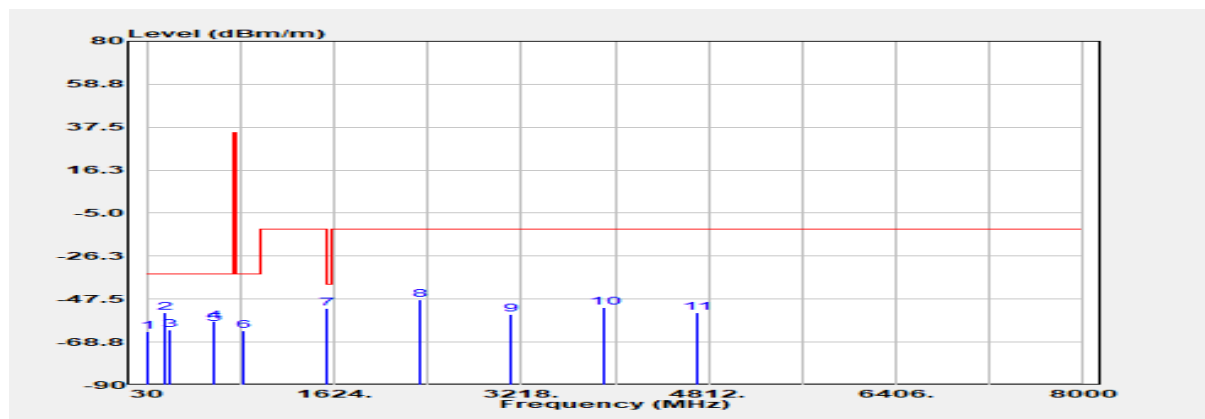

Freq. MHz	EIRP/ERP dBm	SG Output Level dBm	Antenna Gain dBi/dBd	Cable Loss dB	Limit dBm	Margin dB
31.940	-63.57	-43.69	-19.56	-0.32	-35.00	-28.57
180.350	-54.13	-49.58	-3.75	-0.80	-35.00	-19.13
227.880	-62.88	-62.16	0.18	-0.90	-35.00	-27.88
592.600	-58.30	-55.72	-1.14	-1.44	-35.00	-23.30
601.330	-59.66	-57.15	-1.31	-1.20	-35.00	-24.66
859.350	-62.95	-60.17	-1.24	-1.54	-35.00	-27.95
1569.000	-52.23	-59.04	9.22	-2.41	-40.00	-12.23
2353.500	-47.74	-54.44	9.64	-2.94	-13.00	-34.74
3138.000	-55.17	-63.15	11.32	-3.34	-13.00	-42.17
3922.500	-51.47	-59.96	12.35	-3.86	-13.00	-38.47
4707.000	-54.07	-62.13	12.31	-4.25	-13.00	-41.07

Unless otherwise stated the results shown in this test report refer only to the sample(s) tested and such sample(s) are retained for 90 days only.

除非另有說明，此報告結果僅對測試之樣品負責，同時此樣品僅保留90天。本報告未經本公司書面許可，不可部份複製。

This document is issued by the Company subject to its General Conditions of Service printed overleaf, available on request or accessible at <http://www.sgs.com.tw/Terms-and-Conditions> and for electronic format documents, subject to Terms and Conditions for Electronic Documents at <http://www.sgs.com.tw/Terms-and-Conditions>. Attention is drawn to the limitation of liability, indemnification and jurisdiction issues defined therein. Any holder of this document is advised that information contained hereon reflects the Company's findings at the time of its intervention only and within the limits of Client's instructions, if any. The Company's sole responsibility is to its Client and this document does not exonerate parties to a transaction from exercising all their rights and obligations under the transaction documents. This document cannot be reproduced except in full, without prior written approval of the Company. Any unauthorized alteration, forgery or falsification of the content or appearance of this document is unlawful and offenders may be prosecuted to the fullest extent of the law.

Report Number :E2/2022/20116
 Operation Mode :LTE B13
 Test Mode :TX CH HIGH
 EUT Pol :E2 Plane
 Test Frequency :784.5 MHz

Test Site :SAC D
 Test Date :2022-03-22
 Temp./Humi. :20.3/70
 Antenna Pol. :Horizontal
 Engineer :Jack Tseng

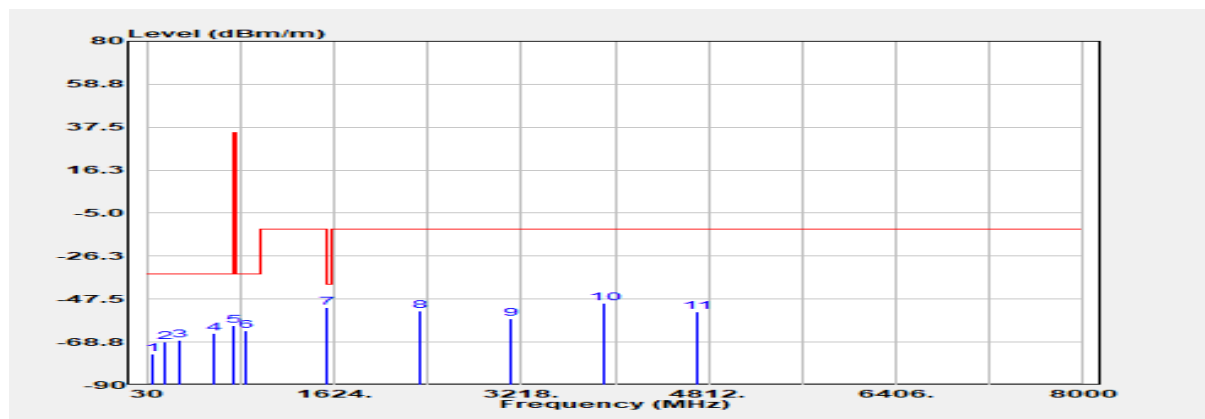

Freq. MHz	EIRP/ERP dBm	SG Output Level dBm	Antenna Gain dBi/dBd	Cable Loss dB	Limit dBm	Margin dB
71.710	-74.65	-62.61	-11.55	-0.49	-35.00	-39.65
180.350	-68.58	-64.03	-3.75	-0.80	-35.00	-33.58
299.660	-67.66	-65.59	-1.00	-1.07	-35.00	-32.66
592.600	-64.43	-61.85	-1.14	-1.44	-35.00	-29.43
777.870	-60.58	-57.62	-1.58	-1.38	34.77	-95.35
866.140	-63.33	-60.55	-1.19	-1.59	-35.00	-28.33
1569.000	-51.81	-58.62	9.22	-2.41	-40.00	-11.81
2353.500	-53.43	-60.13	9.64	-2.94	-13.00	-40.43
3138.000	-57.07	-65.05	11.32	-3.34	-13.00	-44.07
3922.500	-49.68	-58.17	12.35	-3.86	-13.00	-36.68
4707.000	-53.98	-62.04	12.31	-4.25	-13.00	-40.98

Unless otherwise stated the results shown in this test report refer only to the sample(s) tested and such sample(s) are retained for 90 days only.

除非另有說明，此報告結果僅對測試之樣品負責，同時此樣品僅保留90天。本報告未經本公司書面許可，不可部份複製。

This document is issued by the Company subject to its General Conditions of Service printed overleaf, available on request or accessible at <http://www.sgs.com.tw/Terms-and-Conditions> and for electronic format documents, subject to Terms and Conditions for Electronic Documents at <http://www.sgs.com.tw/Terms-and-Conditions>. Attention is drawn to the limitation of liability, indemnification and jurisdiction issues defined therein. Any holder of this document is advised that information contained hereon reflects the Company's findings at the time of its intervention only and within the limits of Client's instructions, if any. The Company's sole responsibility is to its Client and this document does not exonerate parties to a transaction from exercising all their rights and obligations under the transaction documents. This document cannot be reproduced except in full, without prior written approval of the Company. Any unauthorized alteration, forgery or falsification of the content or appearance of this document is unlawful and offenders may be prosecuted to the fullest extent of the law.

Report Number :E2/2022/20116
 Operation Mode :LTE B17
 Test Mode :TX CH LOW
 EUT Pol :E2 Plane
 Test Frequency :706.5 MHz

Test Site :SAC D
 Test Date :2022-03-23
 Temp./Humi. :20.3/70
 Antenna Pol. :Vertical
 Engineer :Jack Tseng

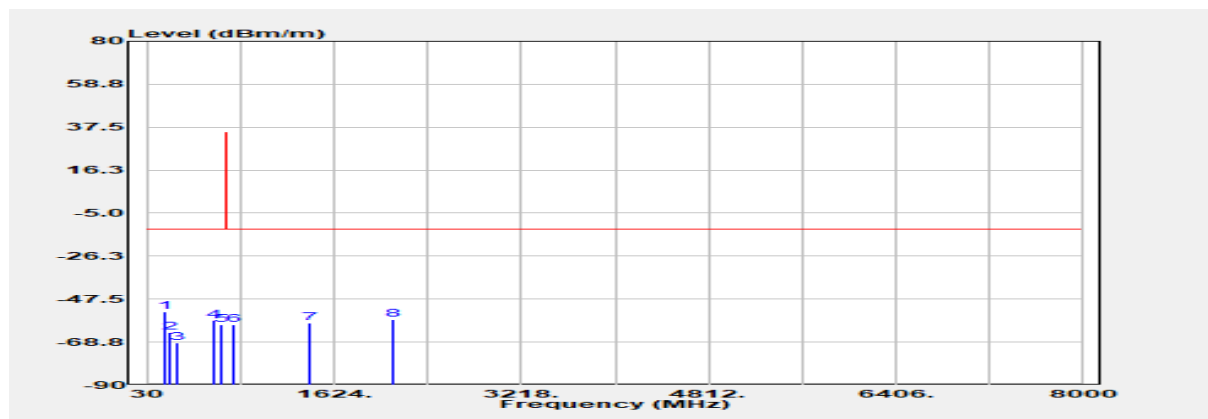

Freq. MHz	EIRP/ERP dBm	SG Output Level dBm	Antenna Gain dBi/dBd	Cable Loss dB	Limit dBm	Margin dB
177.440	-53.96	-48.96	-4.21	-0.79	-13.00	-40.96
226.910	-63.99	-63.32	0.22	-0.89	-13.00	-50.99
295.780	-69.27	-67.19	-1.03	-1.05	-13.00	-56.27
595.510	-58.10	-55.59	-1.16	-1.35	-13.00	-45.10
674.080	-60.25	-57.66	-0.96	-1.63	-13.00	-47.25
769.140	-60.37	-57.46	-1.50	-1.41	-13.00	-47.37
1413.000	-59.32	-64.75	7.71	-2.28	-13.00	-46.32
2119.500	-57.60	-64.46	9.66	-2.80	-13.00	-44.60

Unless otherwise stated the results shown in this test report refer only to the sample(s) tested and such sample(s) are retained for 90 days only.

除非另有說明，此報告結果僅對測試之樣品負責，同時此樣品僅保留90天。本報告未經本公司書面許可，不可部份複製。

This document is issued by the Company subject to its General Conditions of Service printed overleaf, available on request or accessible at <http://www.sgs.com.tw/Terms-and-Conditions> and for electronic format documents, subject to Terms and Conditions for Electronic Documents at <http://www.sgs.com.tw/Terms-and-Conditions>. Attention is drawn to the limitation of liability, indemnification and jurisdiction issues defined therein. Any holder of this document is advised that information contained hereon reflects the Company's findings at the time of its intervention only and within the limits of Client's instructions, if any. The Company's sole responsibility is to its Client and this document does not exonerate parties to a transaction from exercising all their rights and obligations under the transaction documents. This document cannot be reproduced except in full, without prior written approval of the Company. Any unauthorized alteration, forgery or falsification of the content or appearance of this document is unlawful and offenders may be prosecuted to the fullest extent of the law.

Report Number :E2/2022/20116
 Operation Mode :LTE B17
 Test Mode :TX CH LOW
 EUT Pol :E2 Plane
 Test Frequency :706.5 MHz

Test Site :SAC D
 Test Date :2022-03-23
 Temp./Humi. :21.2/66
 Antenna Pol. :Horizontal
 Engineer :Jack Tseng

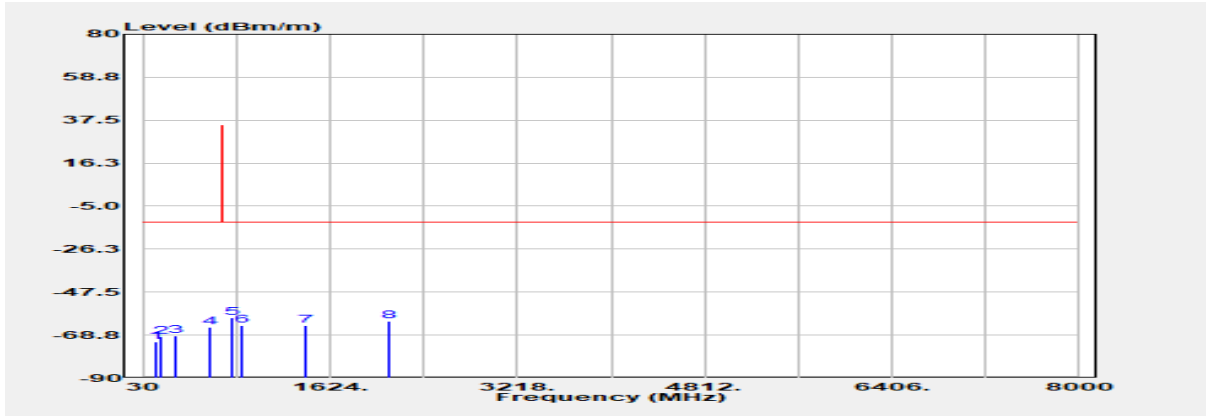

Freq. MHz	EIRP/ERP dBm	SG Output Level dBm	Antenna Gain dBi/dBd	Cable Loss dB	Limit dBm	Margin dB
140.580	-72.27	-64.62	-6.99	-0.66	-13.00	-59.27
181.320	-69.73	-65.42	-3.51	-0.80	-13.00	-56.73
299.660	-68.93	-66.86	-1.00	-1.07	-13.00	-55.93
592.600	-64.75	-62.17	-1.14	-1.44	-13.00	-51.75
782.720	-60.37	-57.43	-1.51	-1.43	-13.00	-47.37
865.170	-63.81	-61.03	-1.20	-1.58	-13.00	-50.81
1413.000	-63.91	-69.34	7.71	-2.28	-13.00	-50.91
2119.500	-61.90	-68.76	9.66	-2.80	-13.00	-48.90

Unless otherwise stated the results shown in this test report refer only to the sample(s) tested and such sample(s) are retained for 90 days only.

除非另有說明，此報告結果僅對測試之樣品負責，同時此樣品僅保留90天。本報告未經本公司書面許可，不可部份複製。

This document is issued by the Company subject to its General Conditions of Service printed overleaf, available on request or accessible at <http://www.sgs.com.tw/Terms-and-Conditions> and for electronic format documents, subject to Terms and Conditions for Electronic Documents at <http://www.sgs.com.tw/Terms-and-Conditions>. Attention is drawn to the limitation of liability, indemnification and jurisdiction issues defined therein. Any holder of this document is advised that information contained hereon reflects the Company's findings at the time of its intervention only and within the limits of Client's instructions, if any. The Company's sole responsibility is to its Client and this document does not exonerate parties to a transaction from exercising all their rights and obligations under the transaction documents. This document cannot be reproduced except in full, without prior written approval of the Company. Any unauthorized alteration, forgery or falsification of the content or appearance of this document is unlawful and offenders may be prosecuted to the fullest extent of the law.

Report Number :E2/2022/20116
 Operation Mode :LTE B17
 Test Mode :TX CH MID
 EUT Pol :E2 Plane
 Test Frequency :710 MHz

Test Site :SAC D
 Test Date :2022-03-23
 Temp./Humi. :21.2/66
 Antenna Pol. :Vertical
 Engineer :Jack Tseng

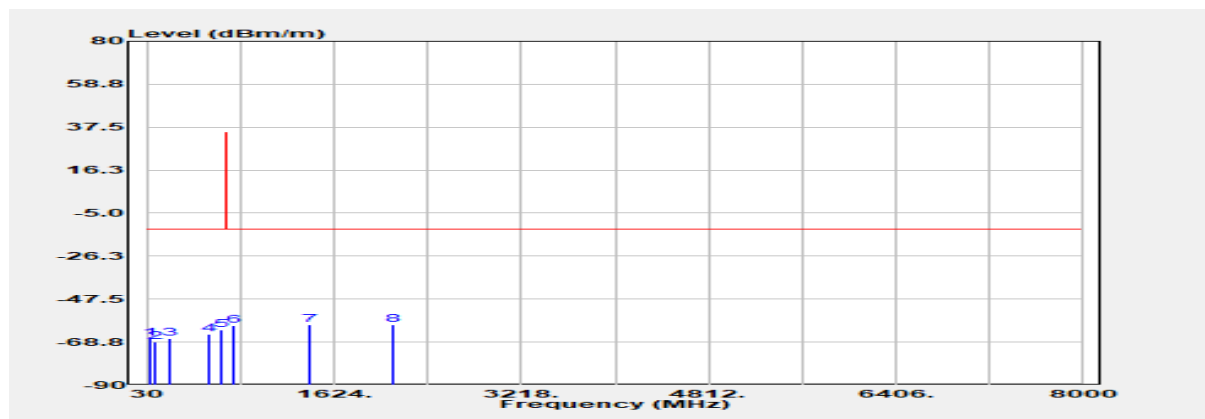

Freq. MHz	EIRP/ERP dBm	SG Output Level dBm	Antenna Gain dBi/dBd	Cable Loss dB	Limit dBm	Margin dB
60.070	-67.11	-51.89	-14.77	-0.45	-13.00	-54.11
108.570	-68.73	-61.84	-6.28	-0.61	-13.00	-55.73
229.820	-67.18	-66.38	0.10	-0.90	-13.00	-54.18
568.350	-64.78	-62.21	-0.81	-1.76	-13.00	-51.78
674.080	-62.69	-60.1	-0.96	-1.63	-13.00	-49.69
777.870	-60.79	-57.83	-1.58	-1.38	-13.00	-47.79
1420.000	-60.13	-65.61	7.76	-2.28	-13.00	-47.13
2130.000	-60.35	-67.09	9.54	-2.80	-13.00	-47.35

Unless otherwise stated the results shown in this test report refer only to the sample(s) tested and such sample(s) are retained for 90 days only.

除非另有說明，此報告結果僅對測試之樣品負責，同時此樣品僅保留90天。本報告未經本公司書面許可，不可部份複製。

This document is issued by the Company subject to its General Conditions of Service printed overleaf, available on request or accessible at <http://www.sgs.com.tw/Terms-and-Conditions> and for electronic format documents, subject to Terms and Conditions for Electronic Documents at <http://www.sgs.com.tw/Terms-and-Conditions>. Attention is drawn to the limitation of liability, indemnification and jurisdiction issues defined therein. Any holder of this document is advised that information contained hereon reflects the Company's findings at the time of its intervention only and within the limits of Client's instructions, if any. The Company's sole responsibility is to its Client and this document does not exonerate parties to a transaction from exercising all their rights and obligations under the transaction documents. This document cannot be reproduced except in full, without prior written approval of the Company. Any unauthorized alteration, forgery or falsification of the content or appearance of this document is unlawful and offenders may be prosecuted to the fullest extent of the law.

Report Number :E2/2022/20116
 Operation Mode :LTE B17
 Test Mode :TX CH MID
 EUT Pol :E2 Plane
 Test Frequency :710 MHz

Test Site :SAC D
 Test Date :2022-03-23
 Temp./Humi. :21.2/66
 Antenna Pol. :Horizontal
 Engineer :Jack Tseng

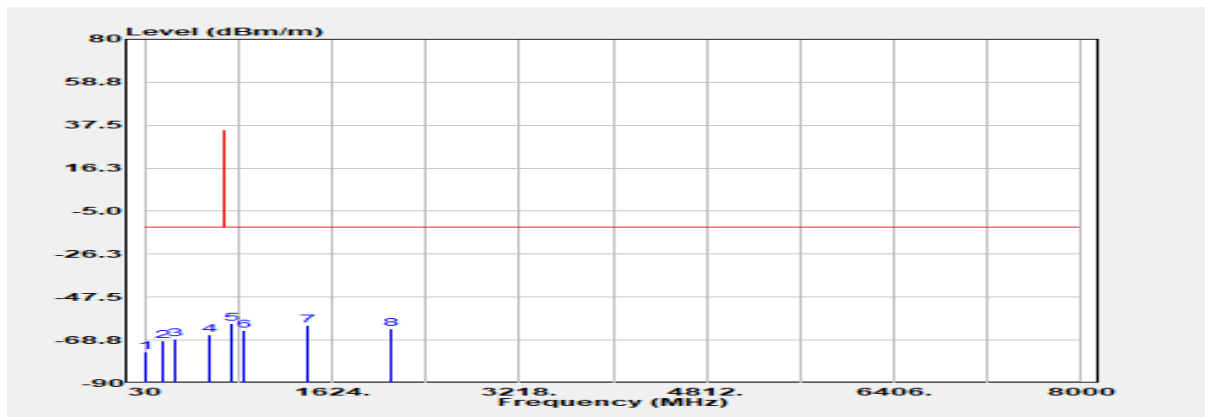

Freq. MHz	EIRP/ERP dBm	SG Output Level dBm	Antenna Gain dBi/dBd	Cable Loss dB	Limit dBm	Margin dB
40.670	-74.55	-55.77	-18.42	-0.36	-13.00	-61.55
181.320	-69.23	-64.92	-3.51	-0.80	-13.00	-56.23
297.720	-68.35	-66.27	-1.02	-1.06	-13.00	-55.35
582.900	-66.04	-63.35	-0.99	-1.70	-13.00	-53.04
774.960	-60.65	-57.71	-1.55	-1.39	-13.00	-47.65
866.140	-63.82	-61.04	-1.19	-1.59	-13.00	-50.82
1420.000	-61.44	-66.92	7.76	-2.28	-13.00	-48.44
2130.000	-63.20	-69.94	9.54	-2.80	-13.00	-50.20

Unless otherwise stated the results shown in this test report refer only to the sample(s) tested and such sample(s) are retained for 90 days only.

除非另有說明，此報告結果僅對測試之樣品負責，同時此樣品僅保留90天。本報告未經本公司書面許可，不可部份複製。

This document is issued by the Company subject to its General Conditions of Service printed overleaf, available on request or accessible at <http://www.sgs.com.tw/Terms-and-Conditions> and for electronic format documents, subject to Terms and Conditions for Electronic Documents at <http://www.sgs.com.tw/Terms-and-Conditions>. Attention is drawn to the limitation of liability, indemnification and jurisdiction issues defined therein. Any holder of this document is advised that information contained hereon reflects the Company's findings at the time of its intervention only and within the limits of Client's instructions, if any. The Company's sole responsibility is to its Client and this document does not exonerate parties to a transaction from exercising all their rights and obligations under the transaction documents. This document cannot be reproduced except in full, without prior written approval of the Company. Any unauthorized alteration, forgery or falsification of the content or appearance of this document is unlawful and offenders may be prosecuted to the fullest extent of the law.

Report Number :E2/2022/20116
 Operation Mode :LTE B17
 Test Mode :TX CH HIGH
 EUT Pol :E2 Plane
 Test Frequency :713.5 MHz

Test Site :SAC D
 Test Date :2022-03-23
 Temp./Humi. :21.2/66
 Antenna Pol. :Vertical
 Engineer :Jack Tseng

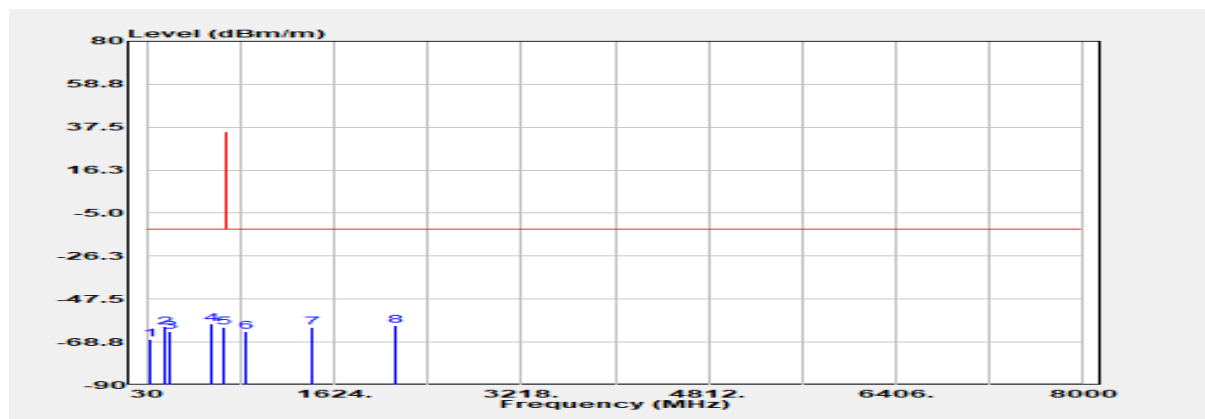

Freq. MHz	EIRP/ERP dBm	SG Output Level dBm	Antenna Gain dBi/dBd	Cable Loss dB	Limit dBm	Margin dB
60.070	-67.33	-52.11	-14.77	-0.45	-13.00	-54.33
188.110	-61.26	-58.11	-2.33	-0.82	-13.00	-48.26
225.940	-63.61	-62.98	0.26	-0.89	-13.00	-50.61
583.870	-59.81	-57.14	-0.99	-1.68	-13.00	-46.81
687.660	-61.62	-59.35	-0.95	-1.32	-13.00	-48.62
867.110	-63.43	-60.65	-1.18	-1.60	-13.00	-50.43
1427.000	-61.44	-66.97	7.82	-2.29	-13.00	-48.44
2140.500	-60.67	-67.27	9.41	-2.81	-13.00	-47.67

Unless otherwise stated the results shown in this test report refer only to the sample(s) tested and such sample(s) are retained for 90 days only.

除非另有說明，此報告結果僅對測試之樣品負責，同時此樣品僅保留90天。本報告未經本公司書面許可，不可部份複製。

This document is issued by the Company subject to its General Conditions of Service printed overleaf, available on request or accessible at <http://www.sgs.com.tw/Terms-and-Conditions> and for electronic format documents, subject to Terms and Conditions for Electronic Documents at <http://www.sgs.com.tw/Terms-and-Conditions>. Attention is drawn to the limitation of liability, indemnification and jurisdiction issues defined therein. Any holder of this document is advised that information contained hereon reflects the Company's findings at the time of its intervention only and within the limits of Client's instructions, if any. The Company's sole responsibility is to its Client and this document does not exonerate parties to a transaction from exercising all their rights and obligations under the transaction documents. This document cannot be reproduced except in full, without prior written approval of the Company. Any unauthorized alteration, forgery or falsification of the content or appearance of this document is unlawful and offenders may be prosecuted to the fullest extent of the law.

Report Number :E2/2022/20116
 Operation Mode :LTE B17
 Test Mode :TX CH HIGH
 EUT Pol :E2 Plane
 Test Frequency :713.5 MHz

Test Site :SAC D
 Test Date :2022-03-23
 Temp./Humi. :21.2/66
 Antenna Pol. :Horizontal
 Engineer :Jack Tseng

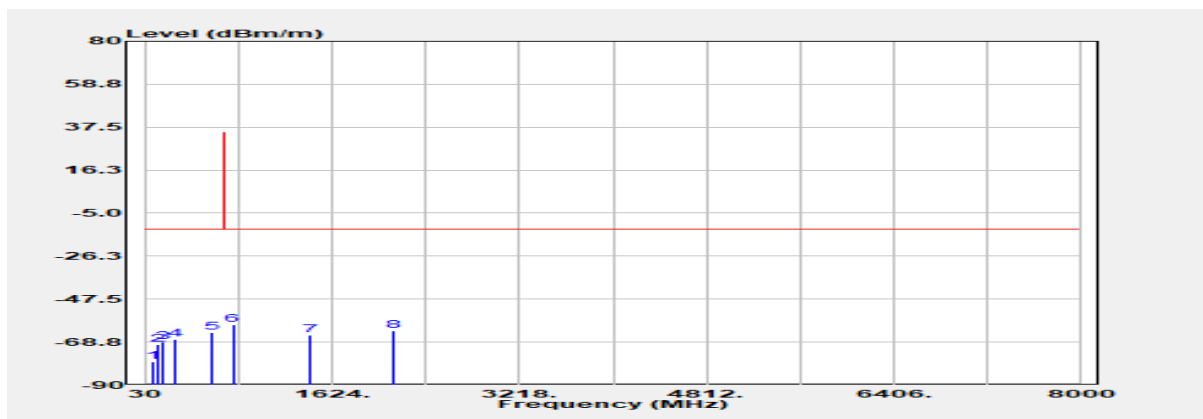

Freq. MHz	EIRP/ERP dBm	SG Output Level dBm	Antenna Gain dBi/dBd	Cable Loss dB	Limit dBm	Margin dB
107.600	-78.71	-71.81	-6.30	-0.60	-13.00	-65.71
132.820	-69.98	-62.34	-6.99	-0.65	-13.00	-56.98
182.290	-68.71	-64.61	-3.30	-0.80	-13.00	-55.71
295.780	-67.24	-65.16	-1.03	-1.05	-13.00	-54.24
599.390	-64.13	-61.64	-1.26	-1.23	-13.00	-51.13
778.840	-60.32	-57.35	-1.59	-1.38	-13.00	-47.32
1427.000	-65.28	-70.81	7.82	-2.29	-13.00	-52.28
2140.500	-63.12	-69.72	9.41	-2.81	-13.00	-50.12

Unless otherwise stated the results shown in this test report refer only to the sample(s) tested and such sample(s) are retained for 90 days only.

除非另有說明，此報告結果僅對測試之樣品負責，同時此樣品僅保留90天。本報告未經本公司書面許可，不可部份複製。

This document is issued by the Company subject to its General Conditions of Service printed overleaf, available on request or accessible at <http://www.sgs.com.tw/Terms-and-Conditions> and for electronic format documents, subject to Terms and Conditions for Electronic Documents at <http://www.sgs.com.tw/Terms-and-Conditions>. Attention is drawn to the limitation of liability, indemnification and jurisdiction issues defined therein. Any holder of this document is advised that information contained hereon reflects the Company's findings at the time of its intervention only and within the limits of Client's instructions, if any. The Company's sole responsibility is to its Client and this document does not exonerate parties to a transaction from exercising all their rights and obligations under the transaction documents. This document cannot be reproduced except in full, without prior written approval of the Company. Any unauthorized alteration, forgery or falsification of the content or appearance of this document is unlawful and offenders may be prosecuted to the fullest extent of the law.

Report Number :E2/2022/20116
 Operation Mode :LTE B66
 Test Mode :TX CH LOW
 EUT Pol :E2 Plane
 Test Frequency :1715 MHz

Test Site :SAC D
 Test Date :2022-03-23
 Temp./Humi. :21.2/66
 Antenna Pol. :Vertical
 Engineer :Jack Tseng

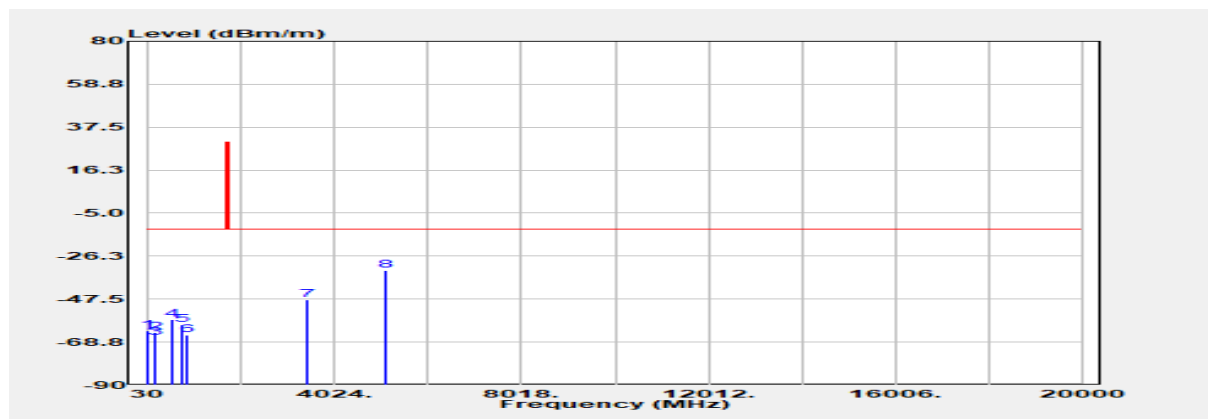

Freq. MHz	EIRP/ERP dBm	SG Output Level dBm	Antenna Gain dBi/dBd	Cable Loss dB	Limit dBm	Margin dB
30.970	-63.37	-43.13	-19.92	-0.32	-13.00	-50.37
182.290	-63.83	-59.73	-3.30	-0.80	-13.00	-50.83
226.910	-66.56	-65.89	0.22	-0.89	-13.00	-53.56
592.600	-57.76	-55.18	-1.14	-1.44	-13.00	-44.76
773.990	-60.08	-57.15	-1.54	-1.39	-13.00	-47.08
866.140	-65.40	-62.62	-1.19	-1.59	-13.00	-52.40
3430.000	-47.63	-56.53	12.54	-3.64	-13.00	-34.63
5145.000	-33.14	-40.75	12.10	-4.49	-13.00	-20.14

Unless otherwise stated the results shown in this test report refer only to the sample(s) tested and such sample(s) are retained for 90 days only.

除非另有說明，此報告結果僅對測試之樣品負責，同時此樣品僅保留90天。本報告未經本公司書面許可，不可部份複製。

This document is issued by the Company subject to its General Conditions of Service printed overleaf, available on request or accessible at <http://www.sgs.com.tw/Terms-and-Conditions> and for electronic format documents, subject to Terms and Conditions for Electronic Documents at <http://www.sgs.com.tw/Terms-and-Conditions>. Attention is drawn to the limitation of liability, indemnification and jurisdiction issues defined therein. Any holder of this document is advised that information contained hereon reflects the Company's findings at the time of its intervention only and within the limits of Client's instructions, if any. The Company's sole responsibility is to its Client and this document does not exonerate parties to a transaction from exercising all their rights and obligations under the transaction documents. This document cannot be reproduced except in full, without prior written approval of the Company. Any unauthorized alteration, forgery or falsification of the content or appearance of this document is unlawful and offenders may be prosecuted to the fullest extent of the law.

Report Number :E2/2022/20116
 Operation Mode :LTE B66
 Test Mode :TX CH LOW
 EUT Pol :E2 Plane
 Test Frequency :1715 MHz

Test Site :SAC D
 Test Date :2022-03-23
 Temp./Humi. :21.2/66
 Antenna Pol. :Horizontal
 Engineer :Jack Tseng

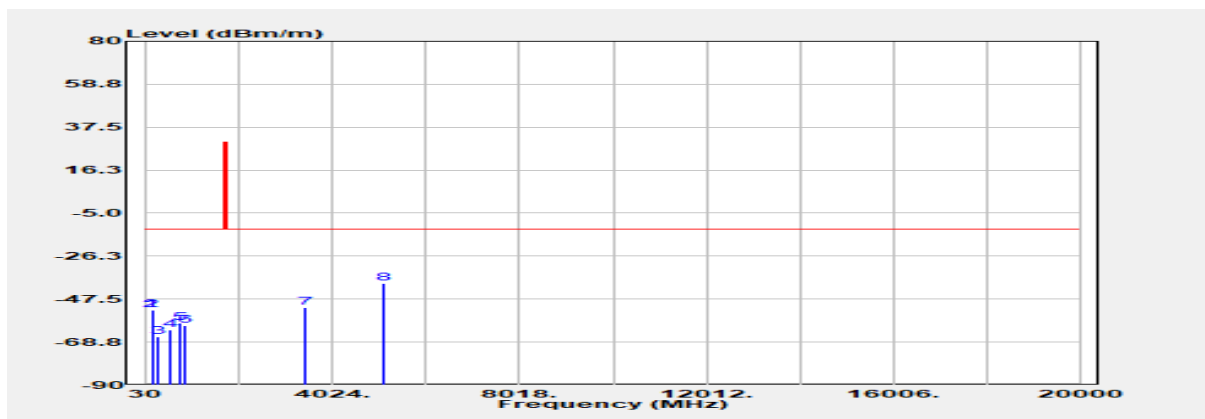

Freq. MHz	EIRP/ERP dBm	SG Output Level dBm	Antenna Gain dBi/dBd	Cable Loss dB	Limit dBm	Margin dB
180.350	-52.90	-48.35	-3.75	-0.80	-13.00	-39.90
180.350	-52.90	-48.35	-3.75	-0.80	-13.00	-39.90
301.600	-65.99	-63.93	-0.98	-1.08	-13.00	-52.99
592.600	-62.91	-60.33	-1.14	-1.44	-13.00	-49.91
774.960	-59.18	-56.24	-1.55	-1.39	-13.00	-46.18
867.110	-60.59	-57.81	-1.18	-1.60	-13.00	-47.59
3430.000	-51.82	-60.72	12.54	-3.64	-13.00	-38.82
5145.000	-39.82	-47.43	12.10	-4.49	-13.00	-26.82

Unless otherwise stated the results shown in this test report refer only to the sample(s) tested and such sample(s) are retained for 90 days only.

除非另有說明，此報告結果僅對測試之樣品負責，同時此樣品僅保留90天。本報告未經本公司書面許可，不可部份複製。

This document is issued by the Company subject to its General Conditions of Service printed overleaf, available on request or accessible at <http://www.sgs.com.tw/Terms-and-Conditions> and for electronic format documents, subject to Terms and Conditions for Electronic Documents at <http://www.sgs.com.tw/Terms-and-Conditions>. Attention is drawn to the limitation of liability, indemnification and jurisdiction issues defined therein. Any holder of this document is advised that information contained hereon reflects the Company's findings at the time of its intervention only and within the limits of Client's instructions, if any. The Company's sole responsibility is to its Client and this document does not exonerate parties to a transaction from exercising all their rights and obligations under the transaction documents. This document cannot be reproduced except in full, without prior written approval of the Company. Any unauthorized alteration, forgery or falsification of the content or appearance of this document is unlawful and offenders may be prosecuted to the fullest extent of the law.

Report Number :E2/2022/20116
 Operation Mode :LTE B66
 Test Mode :TX CH MID
 EUT Pol :E2 Plane
 Test Frequency :1745 MHz

Test Site :SAC D
 Test Date :2022-03-23
 Temp./Humi. :21.2/66
 Antenna Pol. :Vertical
 Engineer :Jack Tseng

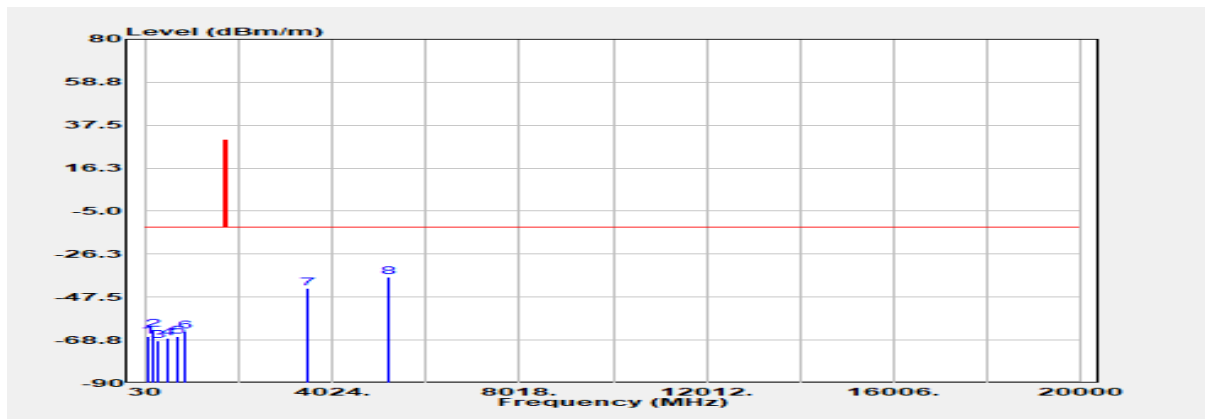

Freq. MHz	EIRP/ERP dBm	SG Output Level dBm	Antenna Gain dBi/dBd	Cable Loss dB	Limit dBm	Margin dB
108.570	-66.92	-60.03	-6.28	-0.61	-13.00	-53.92
225.940	-63.44	-62.81	0.26	-0.89	-13.00	-50.44
302.570	-69.33	-67.27	-0.97	-1.09	-13.00	-56.33
499.480	-67.68	-65.47	-0.67	-1.54	-13.00	-54.68
743.920	-66.93	-63.63	-1.47	-1.83	-13.00	-53.93
872.930	-64.62	-61.78	-1.18	-1.66	-13.00	-51.62
3490.000	-43.14	-51.95	12.42	-3.61	-13.00	-30.14
5235.000	-37.72	-45.92	12.68	-4.48	-13.00	-24.72

Unless otherwise stated the results shown in this test report refer only to the sample(s) tested and such sample(s) are retained for 90 days only.

除非另有說明，此報告結果僅對測試之樣品負責，同時此樣品僅保留90天。本報告未經本公司書面許可，不可部份複製。

This document is issued by the Company subject to its General Conditions of Service printed overleaf, available on request or accessible at <http://www.sgs.com.tw/Terms-and-Conditions> and for electronic format documents, subject to Terms and Conditions for Electronic Documents at <http://www.sgs.com.tw/Terms-and-Conditions>. Attention is drawn to the limitation of liability, indemnification and jurisdiction issues defined therein. Any holder of this document is advised that information contained hereon reflects the Company's findings at the time of its intervention only and within the limits of Client's instructions, if any. The Company's sole responsibility is to its Client and this document does not exonerate parties to a transaction from exercising all their rights and obligations under the transaction documents. This document cannot be reproduced except in full, without prior written approval of the Company. Any unauthorized alteration, forgery or falsification of the content or appearance of this document is unlawful and offenders may be prosecuted to the fullest extent of the law.

Report Number :E2/2022/20116
 Operation Mode :LTE B66
 Test Mode :TX CH MID
 EUT Pol :E2 Plane
 Test Frequency :1745 MHz

Test Site :SAC D
 Test Date :2022-03-23
 Temp./Humi. :21.2/66
 Antenna Pol. :Horizontal
 Engineer :Jack Tseng

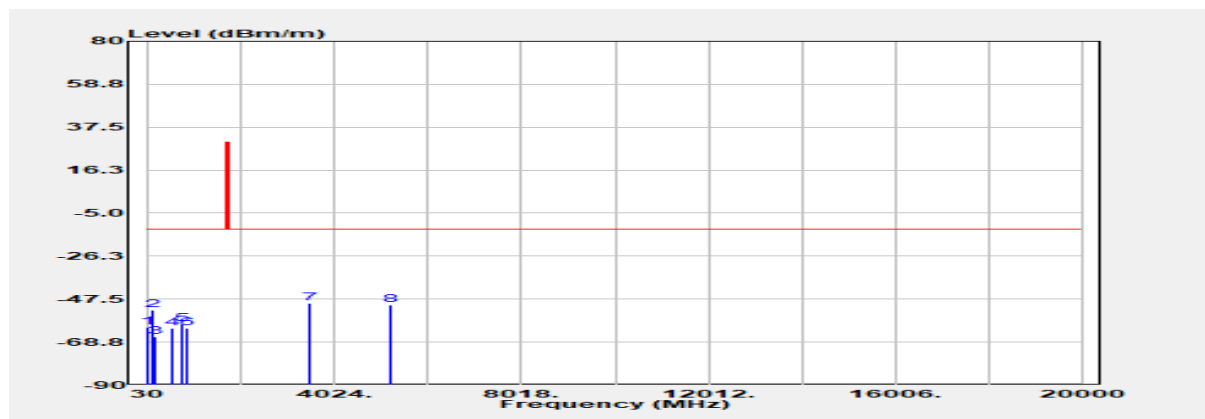

Freq. MHz	EIRP/ERP dBm	SG Output Level dBm	Antenna Gain dBi/dBd	Cable Loss dB	Limit dBm	Margin dB
31.940	-61.52	-41.64	-19.56	-0.32	-13.00	-48.52
178.410	-52.84	-47.98	-4.07	-0.79	-13.00	-39.84
229.820	-66.17	-65.37	0.10	-0.90	-13.00	-53.17
595.510	-61.82	-59.31	-1.16	-1.35	-13.00	-48.82
774.960	-59.67	-56.73	-1.55	-1.39	-13.00	-46.67
866.140	-62.00	-59.22	-1.19	-1.59	-13.00	-49.00
3490.000	-49.67	-58.48	12.42	-3.61	-13.00	-36.67
5235.000	-50.42	-58.62	12.68	-4.48	-13.00	-37.42

Unless otherwise stated the results shown in this test report refer only to the sample(s) tested and such sample(s) are retained for 90 days only.

除非另有說明，此報告結果僅對測試之樣品負責，同時此樣品僅保留90天。本報告未經本公司書面許可，不可部份複製。
 This document is issued by the Company subject to its General Conditions of Service printed overleaf, available on request or accessible at <http://www.sgs.com.tw/Terms-and-Conditions> and for electronic format documents, subject to Terms and Conditions for Electronic Documents at <http://www.sgs.com.tw/Terms-and-Conditions>. Attention is drawn to the limitation of liability, indemnification and jurisdiction issues defined therein. Any holder of this document is advised that information contained hereon reflects the Company's findings at the time of its intervention only and within the limits of Client's instructions, if any. The Company's sole responsibility is to its Client and this document does not exonerate parties to a transaction from exercising all their rights and obligations under the transaction documents. This document cannot be reproduced except in full, without prior written approval of the Company. Any unauthorized alteration, forgery or falsification of the content or appearance of this document is unlawful and offenders may be prosecuted to the fullest extent of the law.

Report Number :E2/2022/20116
 Operation Mode :LTE B66
 Test Mode :TX CH HIGH
 EUT Pol :E2 Plane
 Test Frequency :1775 MHz

Test Site :SAC D
 Test Date :2022-03-23
 Temp./Humi. :21.2/66
 Antenna Pol. :Vertical
 Engineer :Jack Tseng

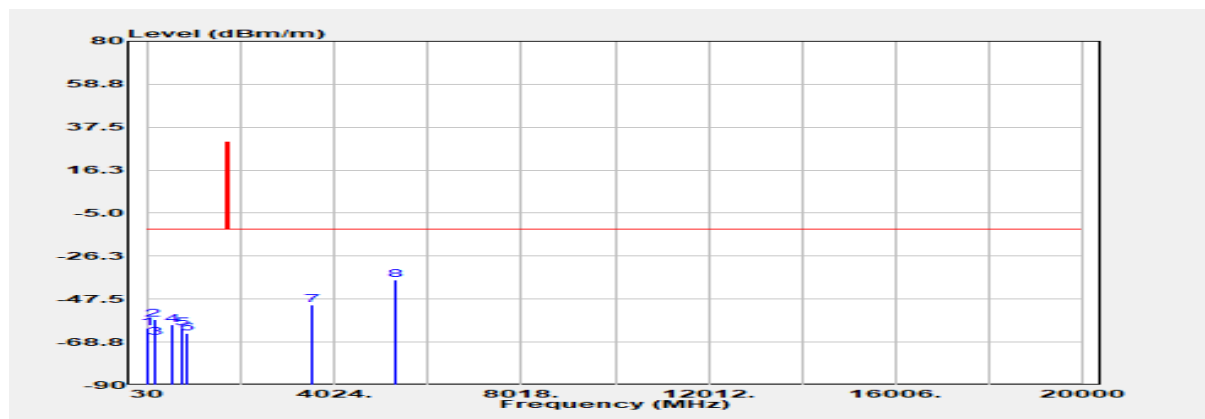

Freq. MHz	EIRP/ERP dBm	SG Output Level dBm	Antenna Gain dBi/dBd	Cable Loss dB	Limit dBm	Margin dB
31.940	-61.76	-41.88	-19.56	-0.32	-13.00	-48.76
181.320	-57.47	-53.16	-3.51	-0.80	-13.00	-44.47
226.910	-66.55	-65.88	0.22	-0.89	-13.00	-53.55
592.600	-60.34	-57.76	-1.14	-1.44	-13.00	-47.34
780.780	-61.67	-58.71	-1.57	-1.39	-13.00	-48.67
863.230	-64.51	-61.72	-1.22	-1.57	-13.00	-51.51
3550.000	-50.22	-58.88	12.40	-3.74	-13.00	-37.22
5325.000	-38.10	-46.56	13.00	-4.54	-13.00	-25.10

Unless otherwise stated the results shown in this test report refer only to the sample(s) tested and such sample(s) are retained for 90 days only.

除非另有說明，此報告結果僅對測試之樣品負責，同時此樣品僅保留90天。本報告未經本公司書面許可，不可部份複製。

This document is issued by the Company subject to its General Conditions of Service printed overleaf, available on request or accessible at <http://www.sgs.com.tw/Terms-and-Conditions> and for electronic format documents, subject to Terms and Conditions for Electronic Documents at <http://www.sgs.com.tw/Terms-and-Conditions>. Attention is drawn to the limitation of liability, indemnification and jurisdiction issues defined therein. Any holder of this document is advised that information contained hereon reflects the Company's findings at the time of its intervention only and within the limits of Client's instructions, if any. The Company's sole responsibility is to its Client and this document does not exonerate parties to a transaction from exercising all their rights and obligations under the transaction documents. This document cannot be reproduced except in full, without prior written approval of the Company. Any unauthorized alteration, forgery or falsification of the content or appearance of this document is unlawful and offenders may be prosecuted to the fullest extent of the law.

Report Number :E2/2022/20116
 Operation Mode :LTE B66
 Test Mode :TX CH HIGH
 EUT Pol :E2 Plane
 Test Frequency :1775 MHz

Test Site :SAC D
 Test Date :2022-03-23
 Temp./Humi. :21.2/66
 Antenna Pol. :Horizontal
 Engineer :Jack Tseng

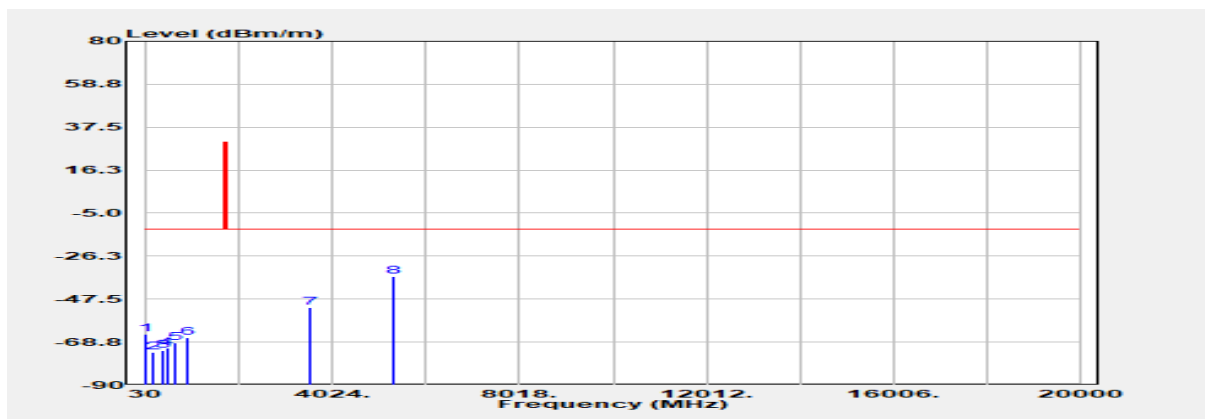

Freq. MHz	EIRP/ERP dBm	SG Output Level dBm	Antenna Gain dBi/dBd	Cable Loss dB	Limit dBm	Margin dB
31.940	-64.69	-44.81	-19.56	-0.32	-13.00	-51.69
229.820	-73.63	-72.83	0.10	-0.90	-13.00	-60.63
405.390	-72.97	-70.88	-0.68	-1.41	-13.00	-59.97
494.630	-71.77	-69.44	-0.74	-1.59	-13.00	-58.77
691.540	-69.02	-66.76	-0.97	-1.29	-13.00	-56.02
948.590	-66.45	-63.26	-1.40	-1.79	-13.00	-53.45
3550.000	-51.64	-60.3	12.40	-3.74	-13.00	-38.64
5325.000	-36.12	-44.58	13.00	-4.54	-13.00	-23.12

Unless otherwise stated the results shown in this test report refer only to the sample(s) tested and such sample(s) are retained for 90 days only.

除非另有說明，此報告結果僅對測試之樣品負責，同時此樣品僅保留90天。本報告未經本公司書面許可，不可部份複製。
 This document is issued by the Company subject to its General Conditions of Service printed overleaf, available on request or accessible at <http://www.sgs.com.tw/Terms-and-Conditions> and for electronic format documents, subject to Terms and Conditions for Electronic Documents at <http://www.sgs.com.tw/Terms-and-Conditions>. Attention is drawn to the limitation of liability, indemnification and jurisdiction issues defined therein. Any holder of this document is advised that information contained hereon reflects the Company's findings at the time of its intervention only and within the limits of Client's instructions, if any. The Company's sole responsibility is to its Client and this document does not exonerate parties to a transaction from exercising all their rights and obligations under the transaction documents. This document cannot be reproduced except in full, without prior written approval of the Company. Any unauthorized alteration, forgery or falsification of the content or appearance of this document is unlawful and offenders may be prosecuted to the fullest extent of the law.

11 FREQUENCY STABILITY MEASUREMENT

11.1 Standard Applicabl

The frequency stability shall be sufficient to ensure that the fundamental emission stays within the authorized frequency block.

11.2 Test Set-up

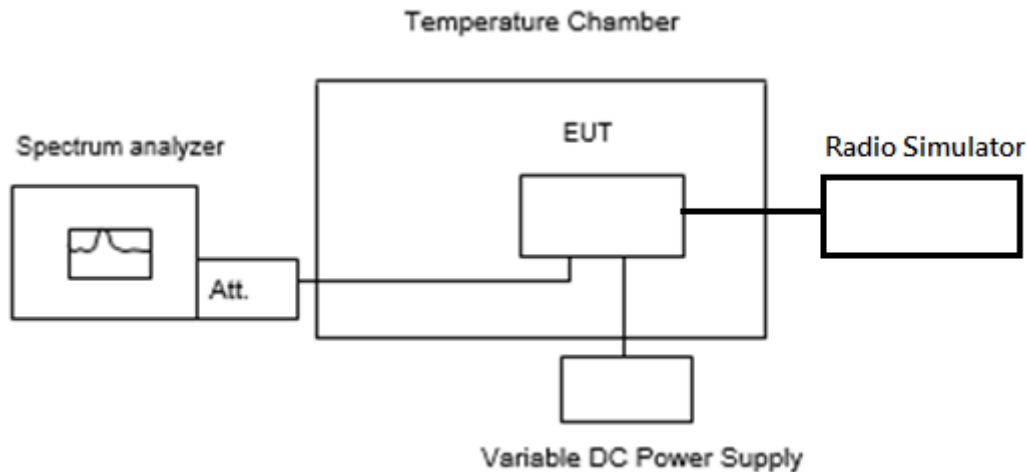

Note: Measurement setup for testing on Antenna connector

11.3 Measurement Procedure

The equipment under test was connected to an external AC or DC power supply and input rated voltage. RF output was connected to a frequency counter or spectrum analyzer via feed through attenuators. The EUT was placed inside the temperature chamber. Set the spectrum analyzer RBW low enough to obtain the desired frequency resolution and measure EUT 25°C operating frequency as reference frequency. Turn EUT off and set the chamber temperature to -30°C. After the temperature stabilized for approximately 30 minutes recorded the frequency. Repeat step measure with 10°C increased per stage until the highest temperature of +50°C reached.

Set chamber temperature to 25°C. Use a variable AC power supply / DC power source to power the EUT and set the voltage to rated voltage. Set the spectrum analyzer RBW low enough to obtain the desired frequency resolution and recorded the frequency. Reduce the input voltage to specify extreme voltage variation (+/- 15%) and endpoint as declared by the manufacturer, record the maximum frequency change.

11.4 Measurement Result

Note: The battery is rated 12V dc.

Unless otherwise stated the results shown in this test report refer only to the sample(s) tested and such sample(s) are retained for 90 days only.

除非另有說明，此報告結果僅對測試之樣品負責，同時此樣品僅保留90天。本報告未經本公司書面許可，不可部份複製。

This document is issued by the Company subject to its General Conditions of Service printed overleaf, available on request or accessible at <http://www.sgs.com.tw/Terms-and-Conditions> and for electronic format documents, subject to Terms and Conditions for Electronic Documents at <http://www.sgs.com.tw/Terms-and-Conditions>. Attention is drawn to the limitation of liability, indemnification and jurisdiction issues defined therein. Any holder of this document is advised that information contained hereon reflects the Company's findings at the time of its intervention only and within the limits of Client's instructions, if any. The Company's sole responsibility is to its Client and this document does not exonerate parties to a transaction from exercising all their rights and obligations under the transaction documents. This document cannot be reproduced except in full, without prior written approval of the Company. Any unauthorized alteration, forgery or falsification of the content or appearance of this document is unlawful and offenders may be prosecuted to the fullest extent of the law.

Reference Freq.:		LTE B2 Mid Channel		1880.0000	MHz 10M QPSK CH 18900
Power Supply Vdc	Temp. (°C)	Freq. (MHz)	(ppm)	Limit	
Freq. ERROR vs. VOLTAGE					
13.8	25	1880.000000	0.0000	+/- 2.5 ppm	
12	25	1880.000007	0.0037		
10.2	25	1879.999997	-0.0016		
10 (End Point)	25	1879.999998	-0.0011		
Freq. ERROR vs. Temp.					
12	-30	1880.000005	0.0027	+/- 2.5 ppm	
12	-20	1879.999996	-0.0021		
12	-10	1880.000003	0.0016		
12	0	1880.000005	0.0027		
12	10	1879.999995	-0.0027		
12	20	1879.999996	-0.0021		
12	30	1880.000000	0.0000		
12	40	1880.000002	0.0011		
12	50	1879.999997	-0.0016		
Reference Freq.:		LTE B4 Mid Channel		1732.5000	MHz 10M QPSK CH 20175
Power Supply Vdc	Temp. (°C)	Freq. (MHz)	(ppm)	Limit	
Freq. ERROR vs. VOLTAGE					
13.8	25	1732.500005	0.0029	+/- 2.5 ppm	
12	25	1732.500006	0.0035		
10.2	25	1732.500003	0.0017		
10 (End Point)	25	1732.499996	-0.0023		
Freq. ERROR vs. Temp.					
12	-30	1732.500000	0.0000	+/- 2.5 ppm	
12	-20	1732.500006	0.0035		
12	-10	1732.500002	0.0012		
12	0	1732.500002	0.0012		
12	10	1732.500007	0.0040		
12	20	1732.500004	0.0023		
12	30	1732.500005	0.0029		
12	40	1732.500003	0.0017		
12	50	1732.500006	0.0035		

Unless otherwise stated the results shown in this test report refer only to the sample(s) tested and such sample(s) are retained for 90 days only.

除非另有說明，此報告結果僅對測試之樣品負責，同時此樣品僅保留90天。本報告未經本公司書面許可，不可部份複製。

This document is issued by the Company subject to its General Conditions of Service printed overleaf, available on request or accessible at <http://www.sgs.com.tw/Terms-and-Conditions> and for electronic format documents, subject to Terms and Conditions for Electronic Documents at <http://www.sgs.com.tw/Terms-and-Conditions>. Attention is drawn to the limitation of liability, indemnification and jurisdiction issues defined therein. Any holder of this document is advised that information contained hereon reflects the Company's findings at the time of its intervention only and within the limits of Client's instructions, if any. The Company's sole responsibility is to its Client and this document does not exonerate parties to a transaction from exercising all their rights and obligations under the transaction documents. This document cannot be reproduced except in full, without prior written approval of the Company. Any unauthorized alteration, forgery or falsification of the content or appearance of this document is unlawful and offenders may be prosecuted to the fullest extent of the law.

Reference Freq.:		LTE B5 Mid Channel		836.5000	MHz 10M QPSK CH 20525
Power Supply Vdc	Temp. (°C)	Freq. (MHz)	(ppm)	Limit	
Freq. ERROR vs. VOLTAGE					
13.8	25	836.500008	0.0096	+/- 2.5 ppm	
12	25	836.500003	0.0036		
10.2	25	836.499999	-0.0012		
10 (End Point)	25	836.500009	0.0108		
Freq. ERROR vs. Temp.					
12	-30	836.500005	0.0060	+/- 2.5 ppm	
12	-20	836.500008	0.0096		
12	-10	836.500006	0.0072		
12	0	836.499998	-0.0024		
12	10	836.500001	0.0012		
12	20	836.499998	-0.0024		
12	30	836.500004	0.0048		
12	40	836.500004	0.0048		
12	50	836.500005	0.0060		
Reference Freq.:		LTE B12 Mid Channel		707.5000	MHz 10M QPSK CH 23095
Power Supply Vdc	Temp. (°C)	Freq. (MHz)	(ppm)	Limit	
Freq. ERROR vs. VOLTAGE					
13.8	25	707.499999	-0.0014	+/- 2.5 ppm	
12	25	707.500006	0.0085		
10.2	25	707.499999	-0.0014		
10 (End Point)	25	707.500002	0.0028		
Freq. ERROR vs. Temp.					
12	-30	707.500000	0.0000	+/- 2.5 ppm	
12	-20	707.500009	0.0127		
12	-10	707.499999	-0.0014		
12	0	707.500007	0.0099		
12	10	707.499997	-0.0042		
12	20	707.499996	-0.0057		
12	30	707.500004	0.0057		
12	40	707.500001	0.0014		
12	50	707.499997	-0.0042		

Unless otherwise stated the results shown in this test report refer only to the sample(s) tested and such sample(s) are retained for 90 days only.

除非另有說明，此報告結果僅對測試之樣品負責，同時此樣品僅保留90天。本報告未經本公司書面許可，不可部份複製。

This document is issued by the Company subject to its General Conditions of Service printed overleaf, available on request or accessible at <http://www.sgs.com.tw/Terms-and-Conditions> and for electronic format documents, subject to Terms and Conditions for Electronic Documents at <http://www.sgs.com.tw/Terms-and-Conditions>. Attention is drawn to the limitation of liability, indemnification and jurisdiction issues defined therein. Any holder of this document is advised that information contained hereon reflects the Company's findings at the time of its intervention only and within the limits of Client's instructions, if any. The Company's sole responsibility is to its Client and this document does not exonerate parties to a transaction from exercising all their rights and obligations under the transaction documents. This document cannot be reproduced except in full, without prior written approval of the Company. Any unauthorized alteration, forgery or falsification of the content or appearance of this document is unlawful and offenders may be prosecuted to the fullest extent of the law.

Reference Freq.:		LTE B13 Mid Channel		782.0000	MHz 10M QPSK CH 23230
Power Supply Vdc	Temp. (°C)	Freq. (MHz)	(ppm)	Limit	
Freq. ERROR vs. VOLTAGE					
13.8	25	781.999995	-0.0064	+/- 2.5 ppm	
12	25	782.000003	0.0038		
10.2	25	782.000005	0.0064		
10 (End Point)	25	782.000006	0.0077		
Freq. ERROR vs. Temp.					
12	-30	782.000004	0.0051	+/- 2.5 ppm	
12	-20	782.000004	0.0051		
12	-10	781.999998	-0.0026		
12	0	782.000008	0.0102		
12	10	782.000005	0.0064		
12	20	781.999997	-0.0038		
12	30	782.000008	0.0102		
12	40	781.999998	-0.0026		
12	50	782.000006	0.0077		
Reference Freq.:		LTE B17 Mid Channel		710.0000	MHz 10M QPSK CH 23790
Power Supply Vdc	Temp. (°C)	Freq. (MHz)	(ppm)	Limit	
Freq. ERROR vs. VOLTAGE					
13.8	25	710.000006	0.0085	+/- 2.5 ppm	
12	25	709.999999	-0.0014		
10.2	25	710.000001	0.0014		
10 (End Point)	25	710.000003	0.0042		
Freq. ERROR vs. Temp.					
12	-30	710.000009	0.0127	+/- 2.5 ppm	
12	-20	710.000003	0.0042		
12	-10	710.000005	0.0070		
12	0	710.000006	0.0085		
12	10	710.000003	0.0042		
12	20	710.000000	0.0000		
12	30	710.000003	0.0042		
12	40	709.999996	-0.0056		
12	50	710.000004	0.0056		

Unless otherwise stated the results shown in this test report refer only to the sample(s) tested and such sample(s) are retained for 90 days only.

除非另有說明，此報告結果僅對測試之樣品負責，同時此樣品僅保留90天。本報告未經本公司書面許可，不可部份複製。

This document is issued by the Company subject to its General Conditions of Service printed overleaf, available on request or accessible at <http://www.sgs.com.tw/Terms-and-Conditions> and for electronic format documents, subject to Terms and Conditions for Electronic Documents at <http://www.sgs.com.tw/Terms-and-Conditions>. Attention is drawn to the limitation of liability, indemnification and jurisdiction issues defined therein. Any holder of this document is advised that information contained hereon reflects the Company's findings at the time of its intervention only and within the limits of Client's instructions, if any. The Company's sole responsibility is to its Client and this document does not exonerate parties to a transaction from exercising all their rights and obligations under the transaction documents. This document cannot be reproduced except in full, without prior written approval of the Company. Any unauthorized alteration, forgery or falsification of the content or appearance of this document is unlawful and offenders may be prosecuted to the fullest extent of the law.

Reference Freq.:		LTE B66 Mid Channel		1745.0000	MHz 10M QPSK CH 132322
Power Supply Vdc	Temp. (°C)	Freq. (MHz)	(ppm)	Limit	
Freq. ERROR vs. VOLTAGE					
13.8	25	1745.000007	0.0040	+/- 2.5 ppm	
12	25	1745.000009	0.0052		
10.2	25	1745.000003	0.0017		
10 (End Point)	25	1744.999998	-0.0011		
Freq. ERROR vs. Temp.					
12	-30	1745.000004	0.0023	+/- 2.5 ppm	
12	-20	1745.000005	0.0029		
12	-10	1745.000009	0.0052		
12	0	1745.000007	0.0040		
12	10	1744.999999	-0.0006		
12	20	1744.999995	-0.0029		
12	30	1744.999997	-0.0017		
12	40	1745.000008	0.0046		
12	50	1745.000001	0.0006		

Unless otherwise stated the results shown in this test report refer only to the sample(s) tested and such sample(s) are retained for 90 days only.

除非另有說明，此報告結果僅對測試之樣品負責，同時此樣品僅保留90天。本報告未經本公司書面許可，不可部份複製。

This document is issued by the Company subject to its General Conditions of Service printed overleaf, available on request or accessible at <http://www.sgs.com.tw/Terms-and-Conditions> and for electronic format documents, subject to Terms and Conditions for Electronic Documents at <http://www.sgs.com.tw/Terms-and-Conditions>. Attention is drawn to the limitation of liability, indemnification and jurisdiction issues defined therein. Any holder of this document is advised that information contained hereon reflects the Company's findings at the time of its intervention only and within the limits of Client's instructions, if any. The Company's sole responsibility is to its Client and this document does not exonerate parties to a transaction from exercising all their rights and obligations under the transaction documents. This document cannot be reproduced except in full, without prior written approval of the Company. Any unauthorized alteration, forgery or falsification of the content or appearance of this document is unlawful and offenders may be prosecuted to the fullest extent of the law.