



# FCC TEST REPORT

for  
47 CFR Part 24E

Equipment : 2G/3G PDA phone with GPRS, EDGE, Wi-Fi & Bluetooth  
Trade Name : O<sub>2</sub>  
Model No. : Apollo  
FCC ID : HFS-APOLLO  
Tx Frequency Range : PCS : 1850~1910 MHz  
WCDMA Band 2 : 1850~1910 MHz  
Max. ERP/EIRP Power : PCS (GSM) : 0.26 W  
PCS (EDGE) : 0.19 W  
WCDMA Band 2 : 0.07 W  
Emission Designator : GSM : 300KGXW  
EDGE : 300KG7W  
WCDMA : 4M20F9W  
Applicant : **Quanta Computer Inc.**

No. 211, Wen hwa 2nd Road, kuei Shan Hsiang Tao Yuan Shien, Taiwan

- The test result refers exclusively to the test presented test model / sample.
- Without written approval of SPORTON International Inc., the test report shall not be reproduced except in full.
- **Certificate or Test Report must not be used by the applicant to claim the product in this test report endorsement by NVLAP or any agency of U.S. government.**
- The data shown in this test report were carried out on Oct. 25, 2006 at **Sporton International Inc. LAB.**
- Report No.: FG682525, Report Version: Rev. 03.

Roy Wu  
Deputy Manager

**SPORTON International Inc.**

6F, No.106, Sec. 1, Hsin Tai Wu Rd., Hsi Chih, Taipei Hsien, Taiwan, R.O.C.



Table of Contents

History of this test report.....ii

**1. General Information ..... 1**

    1.1. Applicant .....1

    1.2. Manufacturer .....1

    1.3. Basic Description of Equipment under Test.....1

    1.4. Feature of Equipment under Test .....2

    1.5. Report Date.....2

**2 Test Configuration of Equipment under Test .....3**

    2.1 Test Manner .....3

    2.2 Test Mode .....3

    2.3 Connection Diagram of Test System .....4

    2.4 Ancillary Equipment List.....4

**3. General Information of Test Site .....5**

    3.1 Test Voltage .....5

    3.2 Test in Compliance with .....5

    3.3 Frequency Range Investigated .....5

    3.4 Test Distance .....5

**4. Test Data and Test Result.....6**

    4.1 List of Measurements and Examinations .....6

    4.2 RF Output Power .....7

    4.3 ERP / EIRP Measurement .....8

    4.4 Occupied Bandwidth and Band Edge Measurement .....12

    4.5 Conducted Emission .....25

    4.6 Field Strength of Spurious Radiation .....41

    4.7 Frequency Stability (Temperature Variation) .....50

    4.8 Frequency Stability (Voltage Variation).....52

**5 List of Measurement Equipments .....54**

**6 Uncertainty Evaluation.....55**

- Appendix A – External Photographs
- Appendix B – Internal Photographs
- Appendix C – Setup Photographs





## **1. General Information**

### **1.1. Applicant**

**Quanta Computer Inc.**

No. 211, Wen hwa 2nd Road, kuei Shan Hsiang Tao Yuan Shien, Taiwan

### **1.2 Manufacturer**

**Quanta Computer Inc.**

No. 211, Wen hwa 2nd Road, kuei Shan Hsiang Tao Yuan Shien, Taiwan

### **1.3 Basic Description of Equipment under Test**

Equipment : 2G/3G PDA phone with GPRS, EDGE, Wi-Fi & Bluetooth  
Trade Name : O<sub>2</sub>  
Model No. : Apollo  
FCC ID : HFS-APOLLO  
Power Supply Type : Switching  
AC Power Cord : AC 120V, switching, 2 pin  
Adapter : Phihong, PSC05R-050PH  
Battery : Foxlink, XP-09  
Earphone : Merry, 85C212005001

**1.4 Feature of Equipment under Test**

<b>DUT Type :</b>	2G/3G PDA phone with GPRS, EDGE, Wi-Fi & Bluetooth
<b>Trade Name :</b>	O <sub>2</sub>
<b>Model Name :</b>	Apollo
<b>FCC ID :</b>	HFS-APOLLO
<b>Tx Frequency :</b>	PCS : 1850 ~1910 MHz WCDMA Band 2 : 1850~1910 MHz
<b>Rx Frequency :</b>	PCS : 1930 ~ 1990 MHz WCDMA Band 2 : 1930~1990 MHz
<b>Antenna Type :</b>	Fixed Internal
<b>Maximum Output Power to Antenna :</b>	PCS (GSM) : 28.77 dBm PCS (EDGE) :26.0 dBm WCDMA Band 2 : 23.13 dBm
<b>Maximum ERP/EIRP :</b>	PCS (GSM) : 0.26 W (24.22 dBm) PCS (EDGE): 0.19 W (22.80 dBm) WCDMA Band 2 : 0.07 W (18.52 dBm)
<b>HW Version :</b>	D2D
<b>SW Version :</b>	AL1-KLRNC-2.3.25CT-20060922-1
<b>Power Rating (DC/AC , Voltage and Current of RF element or PA) :</b>	DC 3.7V / 1530mA
<b>Digital Modulation Emission :</b>	PCS : GMSK EDGE : 8PSK WCDMA : QPSK
<b>Type of Emission :</b>	GSM : 300KGXW EDGE : 300KG7W WCDMA : 4M20F9W
<b>Device Power Class :</b>	PCS1900 : 1 WCDMA : 3
<b>DUT Stage :</b>	Production Unit

**1.5 Report Date**

EUT Received : Aug. 25, 2006

Report Date : Nov. 09, 2006



## 2 Test Configuration of Equipment under Test

### 2.1 Test Manner

- a. The spurious emission measurements were carried out in semi-anechoic chamber with 3-meter test range.
- b. During all testings, EUT is in link mode with base station emulator at maximum power level.
- c. Frequency range investigated: radiated emission 30 MHz to 9000 MHz for GSM850 and WCDMA Band 5; 30MHz to 19000 MHz for PCS and WCDMA Band 2.

#### 2.1.1 Testing Rationale

RMC 12.2 Kbps is the main test mode for WCDMA. From the appendix B, the conducted output power, the bandedge and the conducted spurious emission for all WCDMA modes have no obvious deviation. Therefore, RMC 12.2 Kbps can be used as the main test mode for all test items.

### 2.2 Test Mode

Application	PCS 1900	WCDMA Band 2
Radiated Emission	<input checked="" type="checkbox"/> Mode 1: PCS1900(GSM) Link + Earphone + Adapter <input checked="" type="checkbox"/> Mode 2: PCS1900(EDGE) Link + Earphone + Adapter	<input checked="" type="checkbox"/> Mode 3: WCDMA Link + Earphone + Adapter
Conducted Measurement	<input checked="" type="checkbox"/> Mode 1: GSM_CH 661 <input checked="" type="checkbox"/> Mode 2: EDGE_CH 661	<input checked="" type="checkbox"/> Mode 3: CH 9400

**2.3 Connection Diagram of Test System**

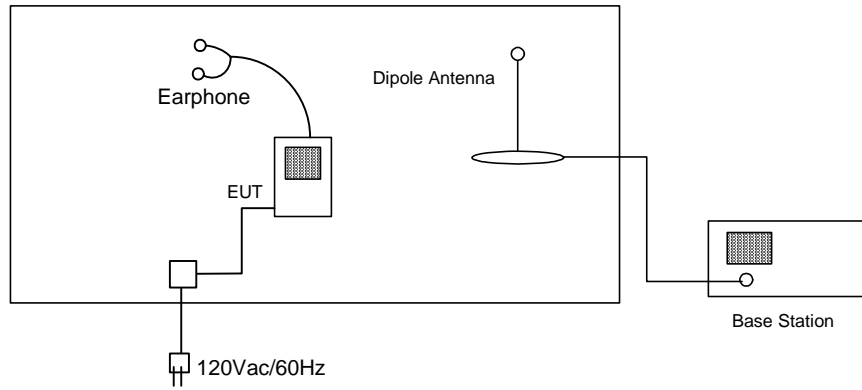

**2.4 Ancillary Equipment List**

Item	Equipment	Model No.	Serial No.
1.	Base Station(R&S)	CMU200	106656



### **3. General Information of Test Site**

Test Site Location : No. 52, Hwa Ya 1st Rd., Hwa Ya Technology Park,  
Kwei-Shan Hsiang, Tao Yuan Hsien, Taiwan, R.O.C.  
TEL : 886-3-327-3456  
FAX : 886-3-318-0055

Test Site No : 03CH06-HY

The chamber meets the characteristics of ANSI C63.4-2003. This site is on file with the FCC. The Industry Canada file number for this site is IC 4088.

#### **3.1 Test Voltage**

120V / 60Hz

#### **3.2 Test in Compliance with**

47 CFR Part 24E

#### **3.3 Frequency Range Investigated**

a. Radiation: from 30 MHz to 19000 MHz for PCS and WCDMA Band 2

#### **3.4 Test Distance**

The test distance of radiated emission from antenna to EUT is 3 m.





#### 4. Test Data and Test Result

##### 4.1 List of Measurements and Examinations

FCC Rule	DESCRIPTION OF TEST	Result	Section
§2.1046	RF Output Power	Passed	4.2
§ 22.913 §24.232	ERP / EIRP	Passed	4.3
§2.1049, § 22.917, § 24.238(b)	Occupied Bandwidth & Band Edge Measurement	Passed	4.4
§2.1051	Conducted Emission	Passed	4.5
§2.1053	Field Strength of Spurious Radiation	Passed	4.6
§2.1055, § 22.355, §24.235	Frequency Stability vs. Temperature	Passed	4.7
§2.1055, §22.355, §24.235	Frequency Stability vs. Voltage	Passed	4.8

## 4.2 RF Output Power

### 4.2.1 Measurement Instruments :

As described in chapter 5 of this test report.

### 4.2.2 Test Procedure :

1. The transmitter output was connected to power meter and base station through power divider.
2. Set EUT at PCL=0 for PCS and WCDMA maximum power through base station.
3. Select lowest, middle, and highest channels for each band.

### 4.2.3 Test Setup Layout :

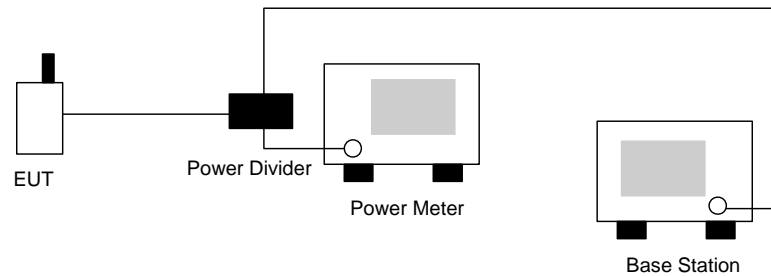

### 4.2.4 Test Result :

Bands	Channel	Frequency (MHz)	Conducted Power (dBm)	Conducted Power (Watts)
PCS (GSM)	512	1850.2 (Low)	28.77	0.741
	661	1880.0 (Mid)	28.68	0.738
	810	1909.8 (High)	28.26	0.670
PCS (EDGE)	512	1850.2 (Low)	26.00	0.398
	661	1880.0 (Mid)	25.90	0.389
	810	1909.8 (High)	25.40	0.347
WCDMA Band 2	9262	1852.4 (Low)	22.48	0.177
	9400	1880.0 (Mid)	22.75	0.188
	9538	1907.6 (High)	23.13	0.206



### 4.3 ERP / EIRP Measurement

Equivalent isotropic radiated power measurements by substitution method according to ANSI/TIA/EIA-603-C.

#### 4.3.1 Measurement Instruments

As described in chapter 5 of this test report.

#### 4.3.2 Test Procedure

1. The EUT was placed on a rotatable table with 1.0 meter height in an fully anechoic chamber.
2. The EUT was set 1.2 meters from the receiving antenna which was mounted on the antenna tower.
3. The table was rotated 360 degrees to determine the position of the highest radiated power.
4. The height of the receiving antenna is also kept at 1.0M height.
5. Taking the record of maximum ERP/EIRP.
6. A dipole antenna was substituted in place of the EUT and was driven by a signal generator.
7. The conducted power at the terminal of the dipole antenna is measured.
8. Repeat step 3 to step 5 to get the maximum ERP/EIRP of the substitution antenna.
9.  $ERP/EIRP = P_s + E_t - E_s + G_s = P_s + R_t - R_s + G_s$

$P_s$  (dBm) : Input power to substitution antenna.

$G_s$  (dBi or dBd) : Substitution antenna Gain.

$E_t = R_t + AF$

$E_s = R_s + AF$

$AF$  (dB/m) : Receive antenna factor

$R_t$  : The highest received signal in Spectrum Analyzer for EUT.

$R_s$  : The highest received signal in spectrum analyzer for substitution antenna.

4.3.3 Test Setup Layout of ERP/EIRP

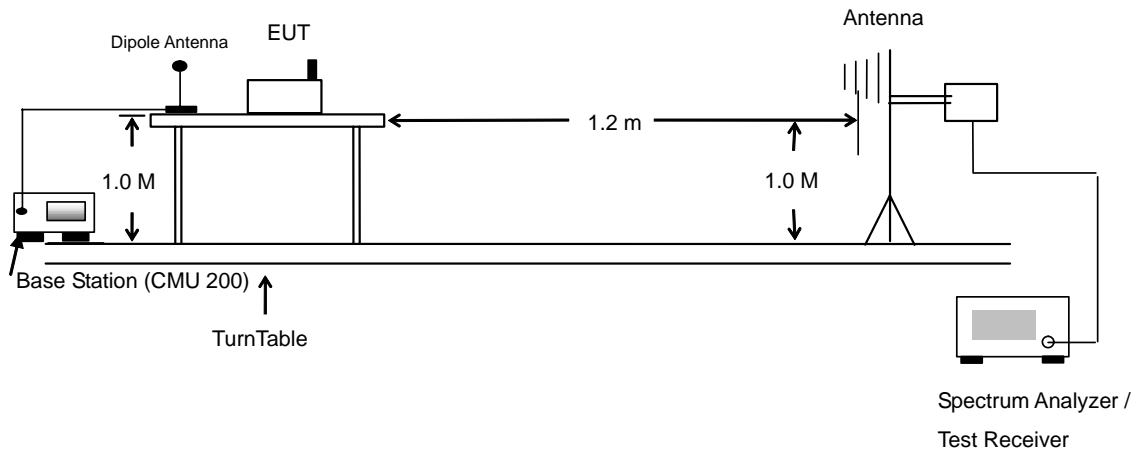



4.3.4 Test Result

<b>PCS (GSM) Radiated Power EIRP</b>						
Horizontal Polarization						
Frequency (MHz)	Rt (dBm)	Rs (dBm)	Ps (dBm)	Gs (dBi)	EIRP (dBm)	EIRP (W)
1850.2	-32.37	-51.88	0.00	1.96	21.47	0.14
1880.0	-33.42	-52.99	0.00	2.00	21.57	0.14
1909.8	-34.08	-54.28	0.00	1.98	22.18	0.17
Vertical Polarization						
Frequency (MHz)	Rt (dBm)	Rs (dBm)	Ps (dBm)	Gs (dBi)	EIRP (dBm)	EIRP (W)
1850.2	-30.23	-52.13	0.00	1.96	23.86	0.24
1880.0	-31.24	-53.17	0.00	2.00	23.93	0.25
<b>1909.8</b>	<b>-31.89</b>	<b>-54.13</b>	<b>0.00</b>	<b>1.98</b>	<b>24.22</b>	<b>0.26</b>

<b>PCS (EDGE) Radiated Power EIRP</b>						
Horizontal Polarization						
Frequency (MHz)	Rt (dBm)	Rs (dBm)	Ps (dBm)	Gs (dBi)	EIRP (dBm)	EIRP (W)
1850.2	-33.32	-51.88	0.00	1.96	20.52	0.11
1880.0	-35.08	-52.99	0.00	2.00	19.91	0.10
1909.8	-37.00	-54.28	0.00	1.98	19.26	0.08
Vertical Polarization						
Frequency (MHz)	Rt (dBm)	Rs (dBm)	Ps (dBm)	Gs (dBi)	EIRP (dBm)	EIRP (W)
<b>1850.2</b>	<b>-31.29</b>	<b>-52.13</b>	<b>0.00</b>	<b>1.96</b>	<b>22.80</b>	<b>0.19</b>
1880.0	-33.35	-53.17	0.00	2.00	21.82	0.15
1909.8	-35.22	-54.13	0.00	1.98	20.89	0.12



<b>WCDMA Band 2 Radiated Power EIRP</b>						
Horizontal Polarization						
Frequency (MHz)	Rt (dBm)	Rs (dBm)	Ps (dBm)	Gs (dBi)	EIRP (dBm)	EIRP (W)
1852.4	-37.53	-51.88	0	1.96	16.31	0.04
1880.0	-38.89	-52.99	0	2	16.10	0.04
1907.6	-40.30	-54.28	0	1.98	15.96	0.04
Vertical Polarization						
Frequency (MHz)	Rt (dBm)	Rs (dBm)	Ps (dBm)	Gs (dBi)	EIRP (dBm)	EIRP (W)
1852.4	-35.60	-52.13	0	1.96	18.49	0.07
1880.0	-36.70	-53.17	0	2	18.47	0.07
<b>1907.6</b>	<b>-37.59</b>	<b>-54.13</b>	<b>0</b>	<b>1.98</b>	<b>18.52</b>	<b>0.07</b>

## 4.4 Occupied Bandwidth and Band Edge Measurement

### 4.4.1 Measurement Instruments

As described in chapter 5 of this test report.

### 4.4.2 Test Procedure

1. The EUT was connected to Spectrum Analyzer and Base Station via power divider.
2. The 99% occupied bandwidth of middle channel for the highest and lowest RF powers were measured.
3. The bandedge of low and high channels for the highest RF powers within the transmitting frequency band were measured. Setting RBW as roughly  $BW/100$ .

### 4.4.3 Test Setup Layout

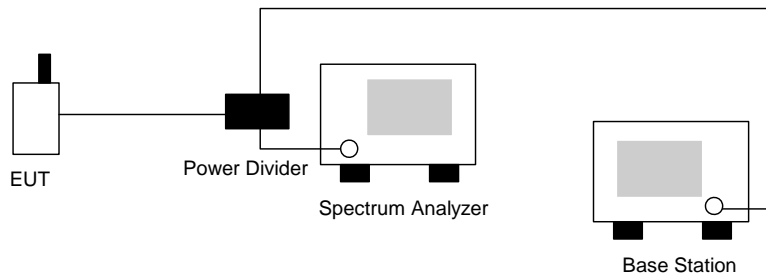



4.4.4 Test Result

- Mode 1
- Test Mode : PCS (GSM) CH512 Lower Band Edge
- Power State : High

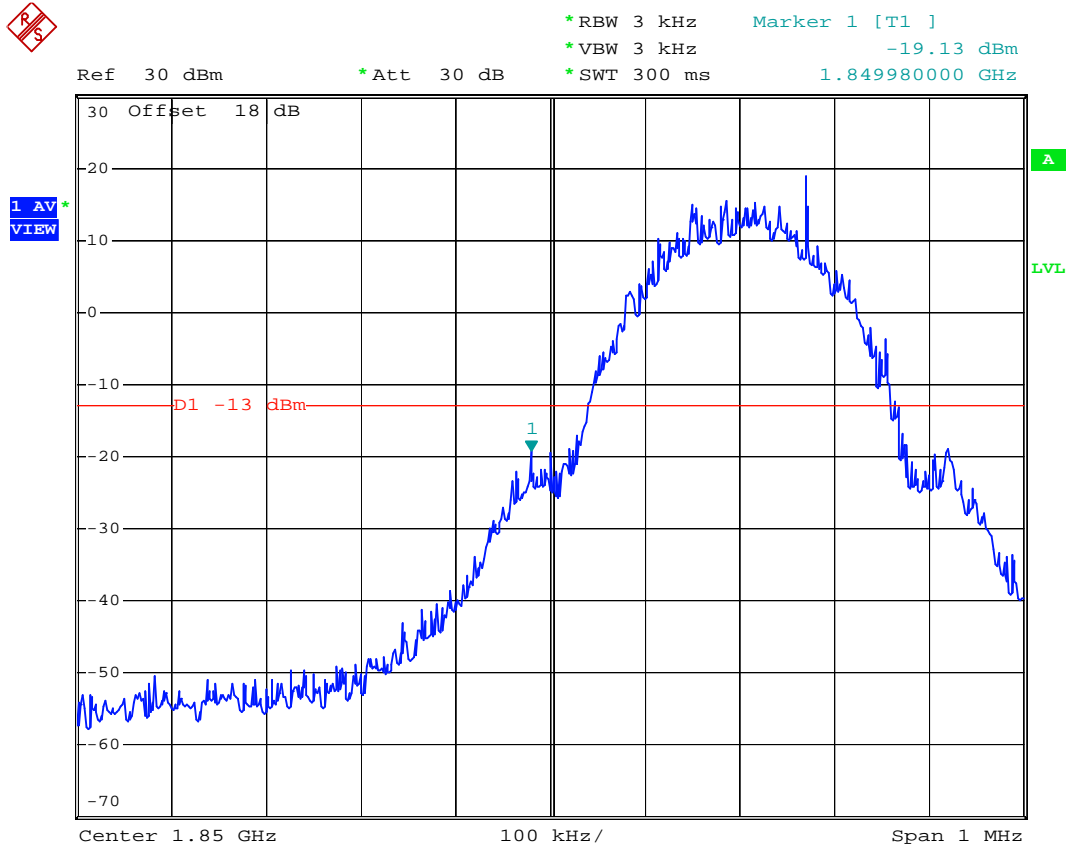

Date: 25.OCT.2006 01:40:59





- Test Mode : PCS (GSM) CH661 99% Occupied Bandwidth
- Power State : Low

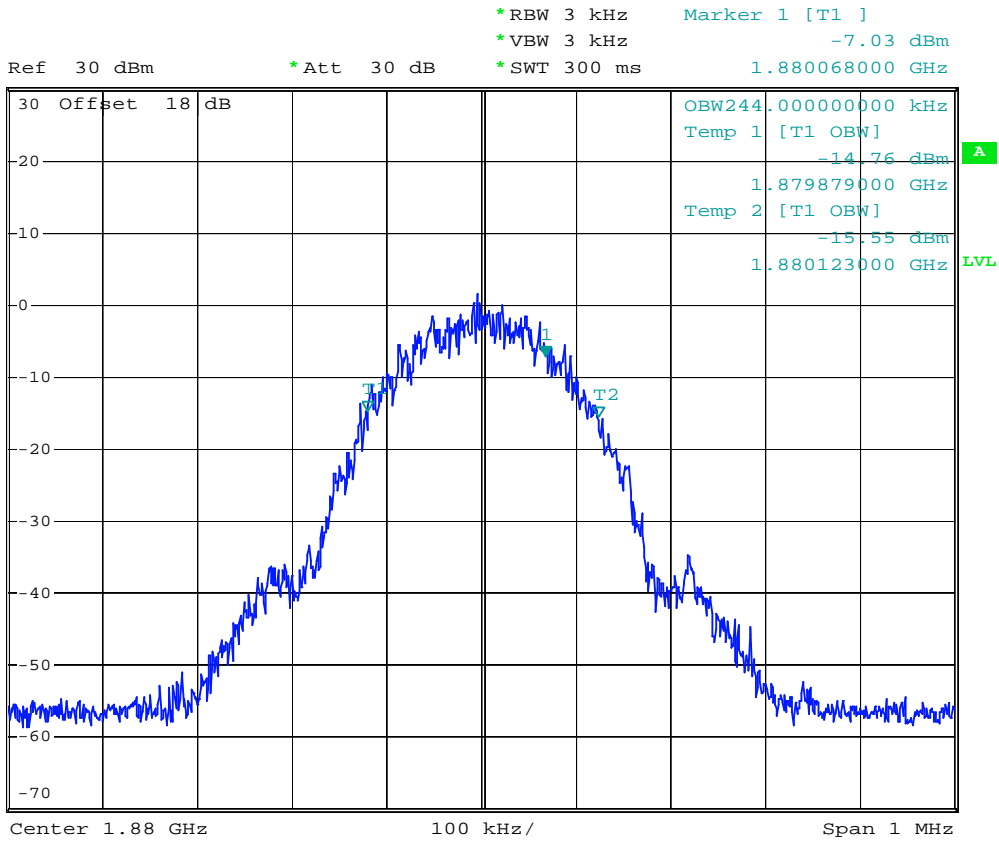

Date: 25.OCT.2006 01:31:20



- Test Mode : PCS (GSM) CH661 99% Occupied Bandwidth
- Power State : High

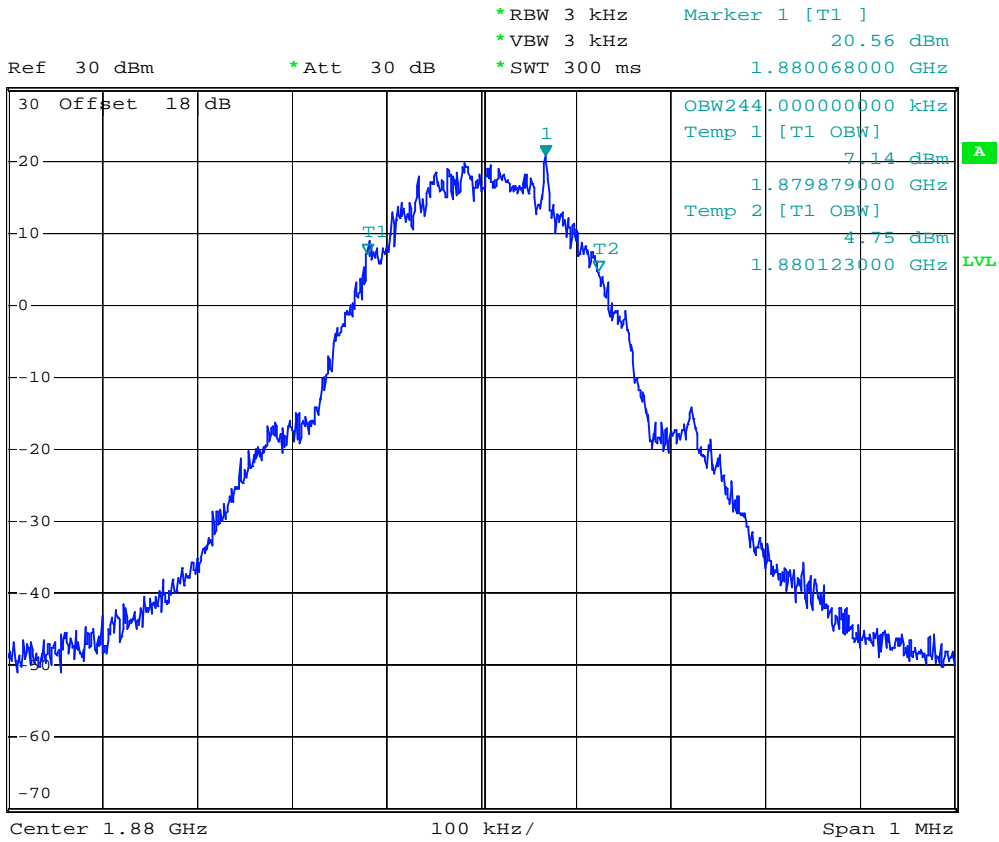

Date: 25.OCT.2006 01:30:29



- Test Mode : PCS (GSM) CH810 Higher Band Edge
- Power State : High



Date: 25.OCT.2006 01:41:51





- Test Mode : PCS (EDGE) CH661 99% Occupied Bandwidth
- Power State : Low

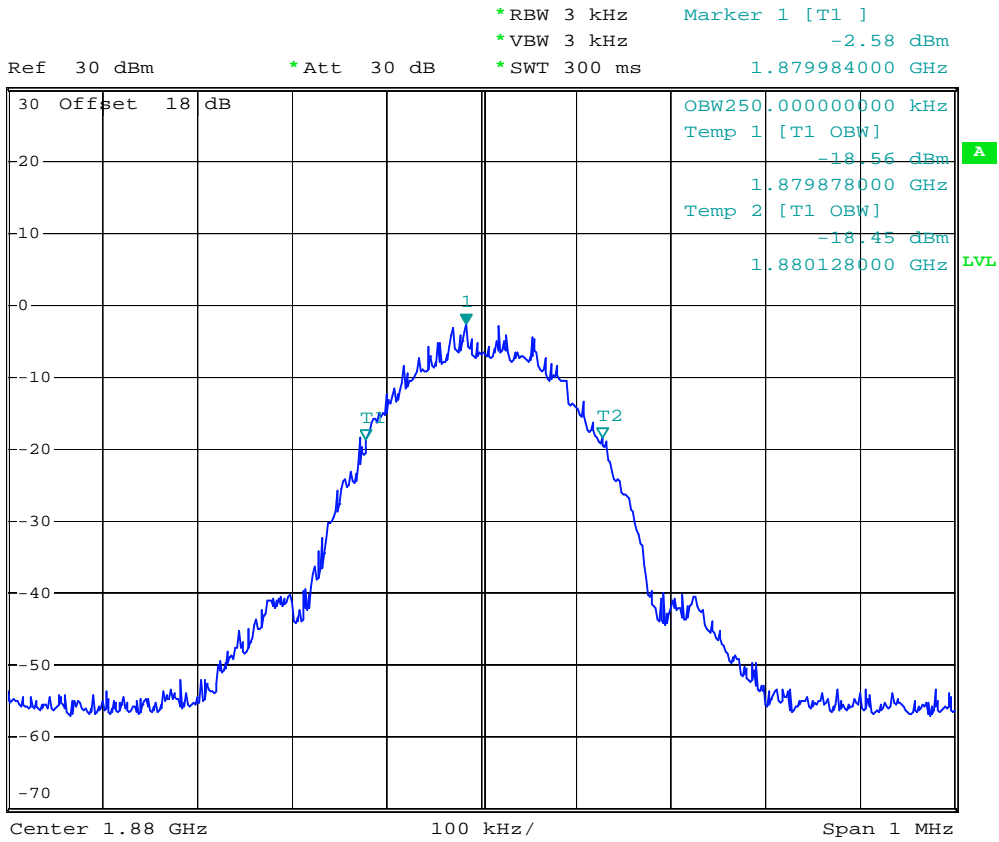

Date: 30.OCT.2006 09:14:55



- Test Mode : PCS (EDGE) CH661 99% Occupied Bandwidth
- Power State : High

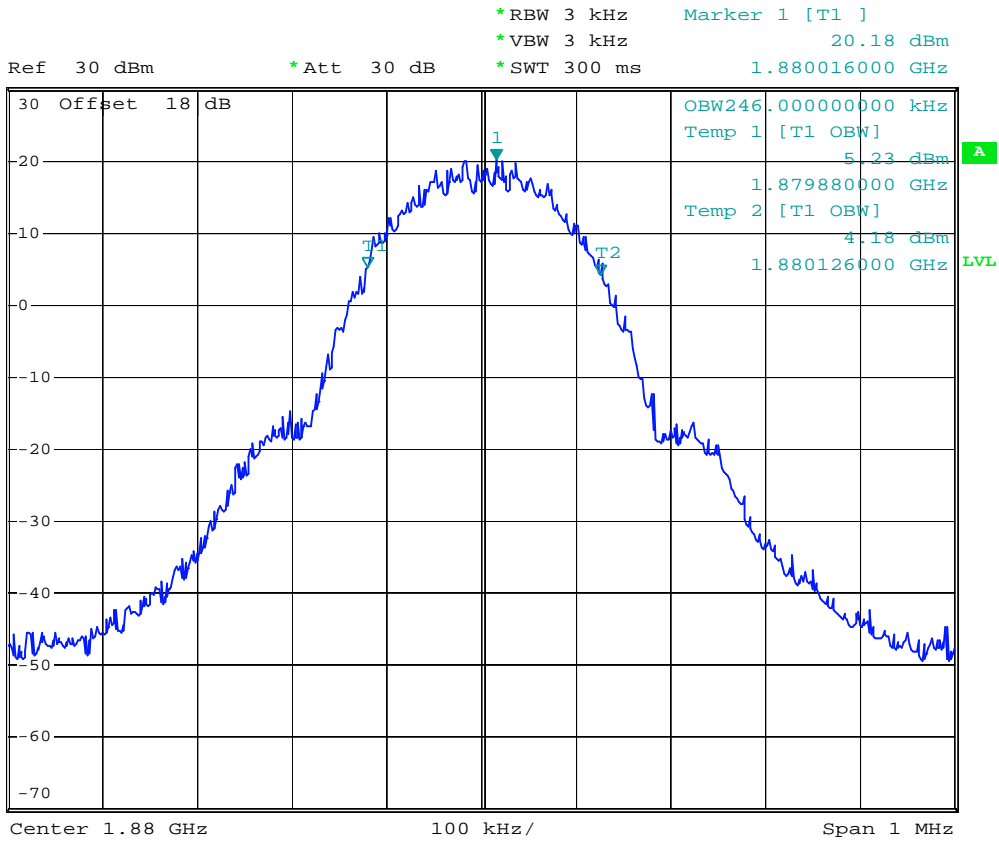

Date: 30.OCT.2006 09:06:41



- Test Mode : PCS (EDGE) CH810 Higher Band Edge
- Power State : High

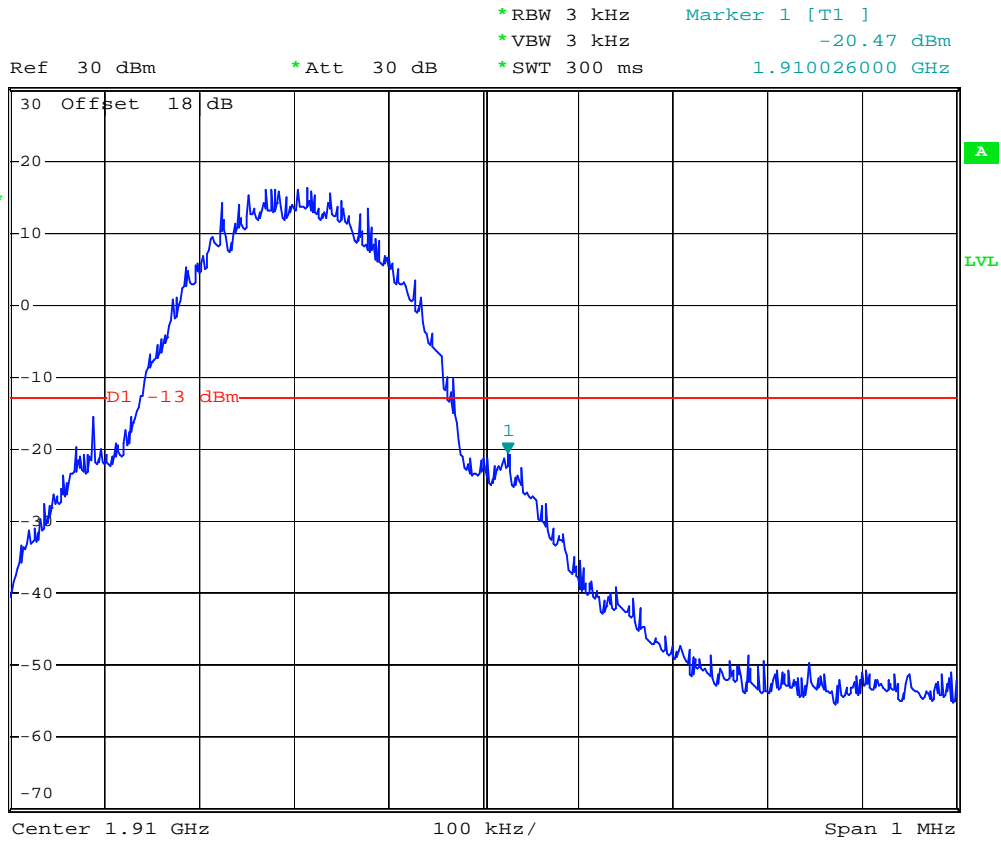

Date: 30.OCT.2006 09:17:55



- Mode 3
- Test Mode : WCDMA Band 2 CH9262 Lower Band Edge
- Power State : High

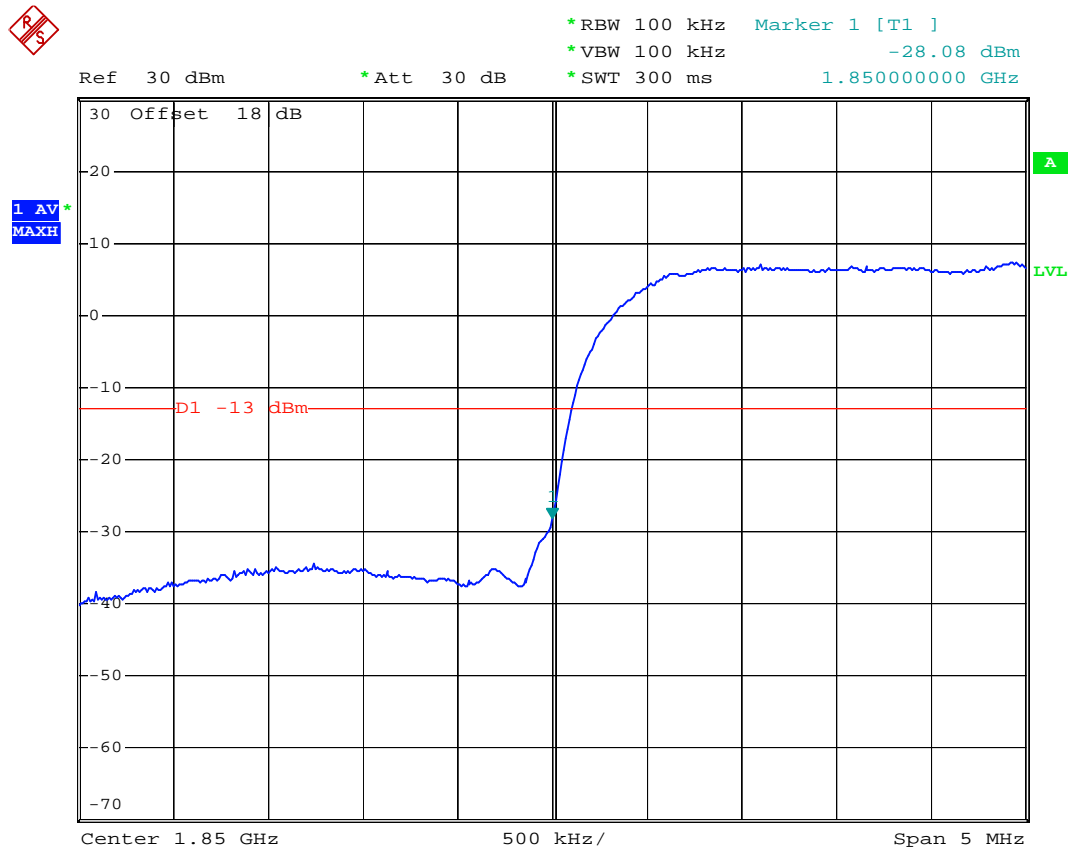

Date: 24.OCT.2006 04:37:18





- Test Mode : WCDMA Band 2 CH9400 99% Occupied Bandwidth
- Power State : Low

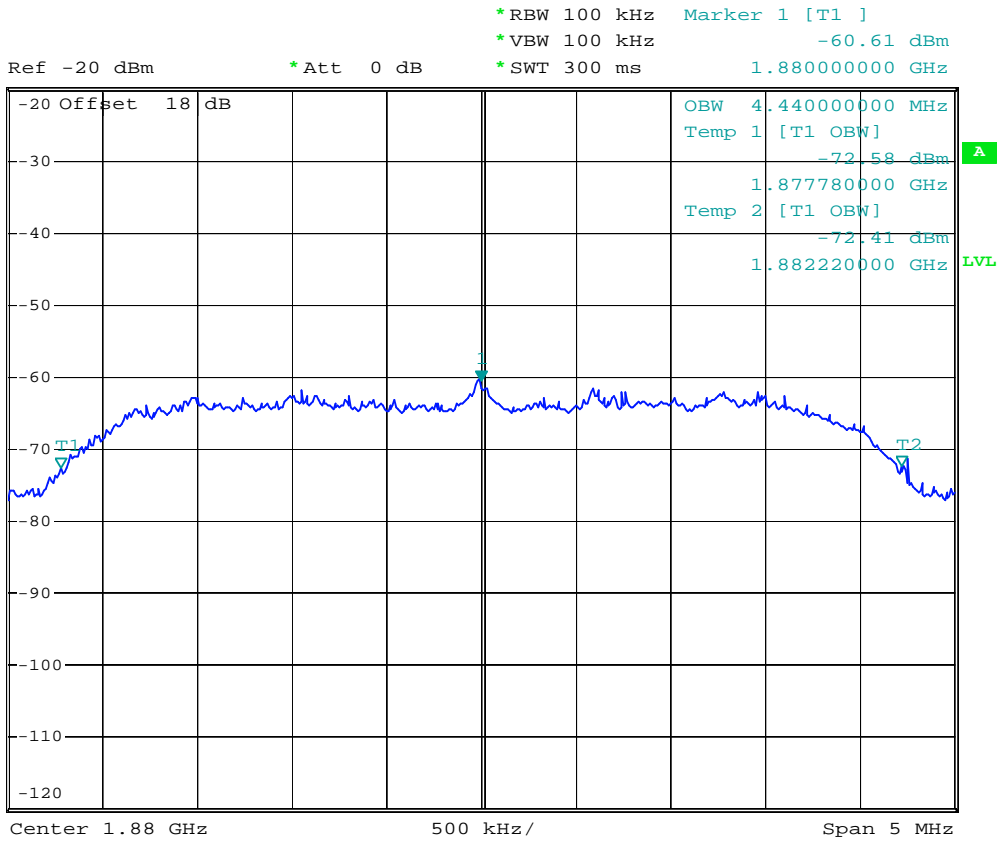

Date: 24.OCT.2006 04:34:39



- Test Mode : WCDMA Band 2 CH9400 99% Occupied Bandwidth
- Power State : High

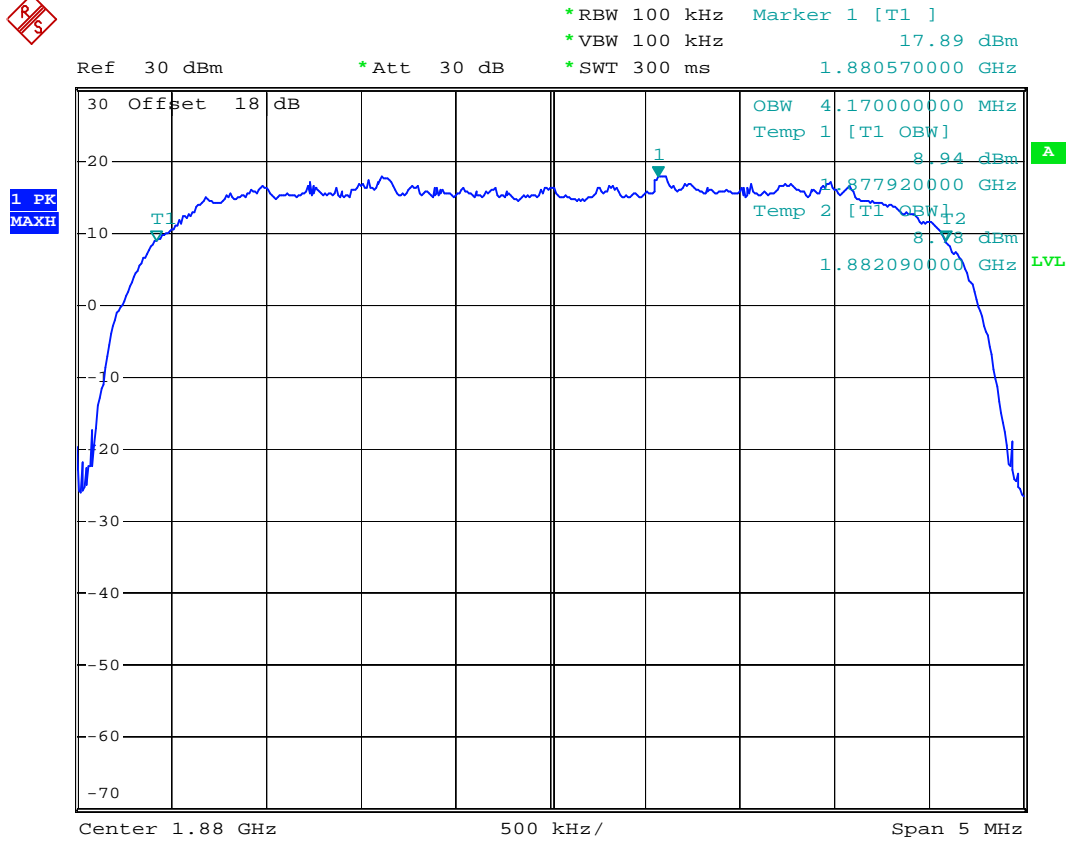

Date: 24.OCT.2006 04:32:21



- Test Mode : WCDMA Band 2 CH9538 Higher Band Edge
- Power State : High

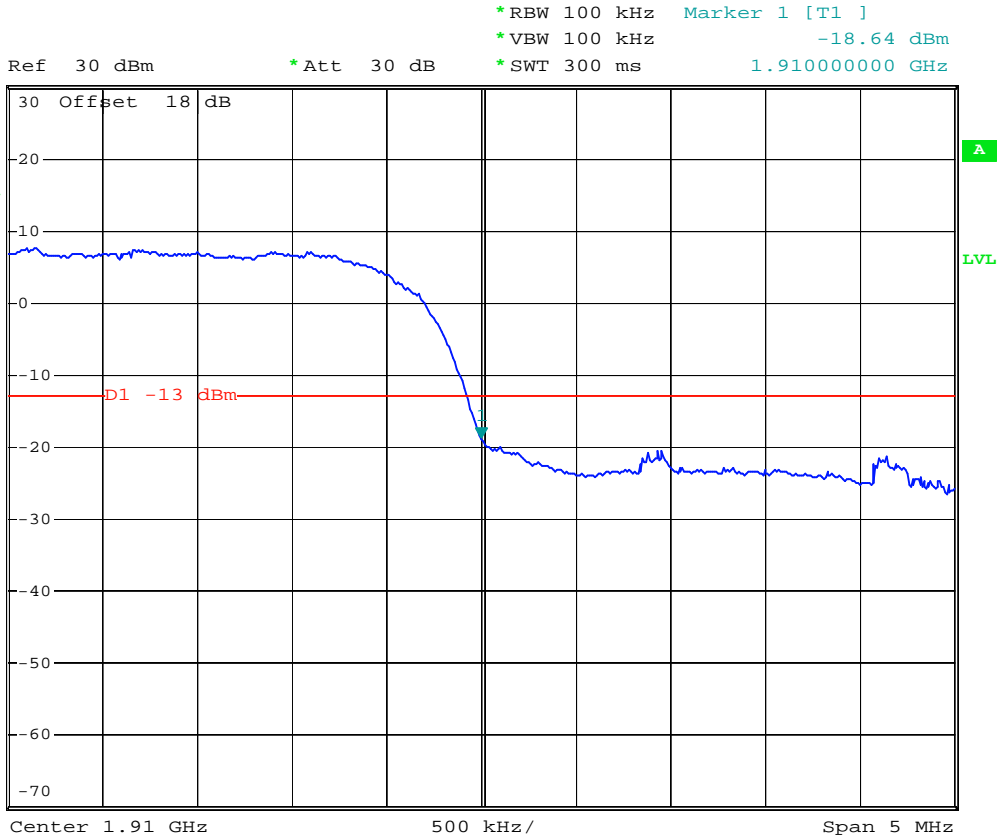

Date: 24.OCT.2006 04:39:06

## 4.5 Conducted Emission

### 4.5.1 Measurement Instruments

As described in chapter 5 of this test report.

### 4.5.2 Test Procedure

1. The EUT was connected to Spectrum Analyzer and Base Station via power divider.
2. The middle channel for the highest RF power within the transmitting frequency was measured.
3. The conducted spurious emission for the whole frequency range was taken.

### 4.5.3 Test Setup Layout

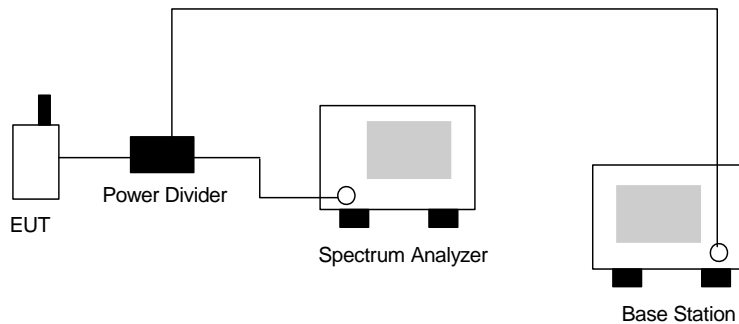



4.5.4 Test Result

- Mode 1
- Test Mode : PCS (GSM) CH661
- Frequency Range : 30M-1G

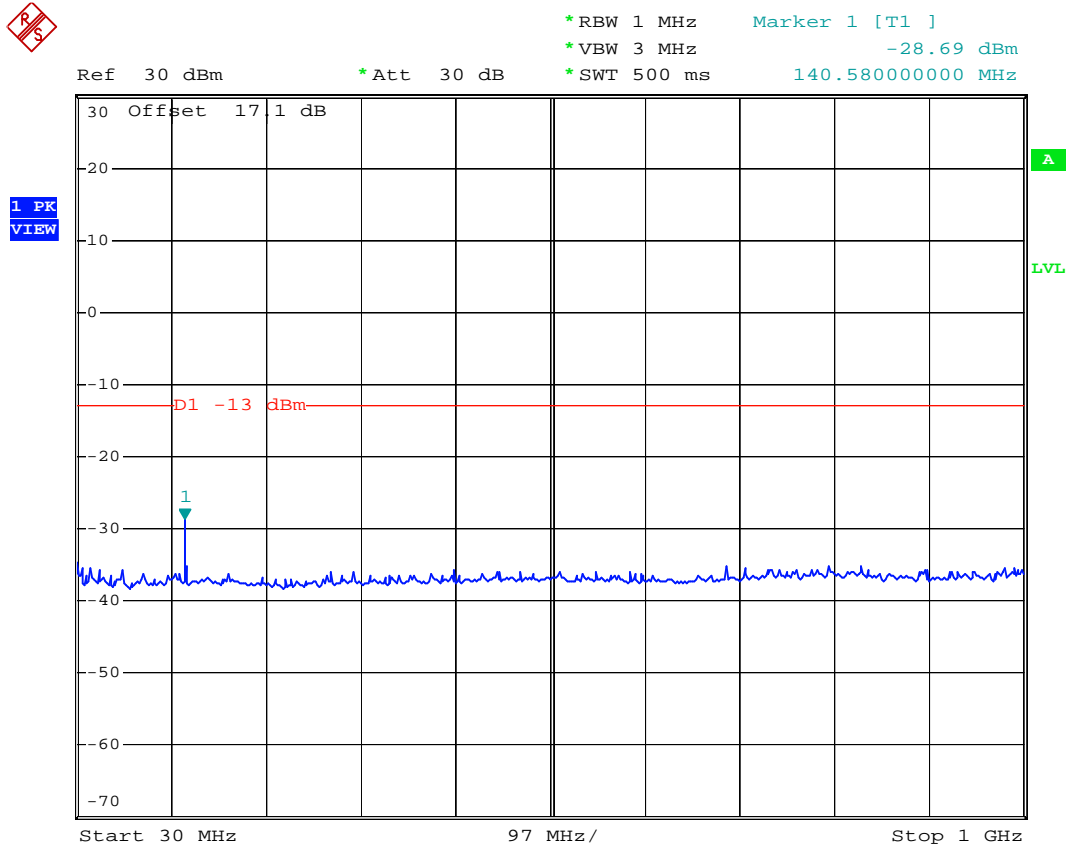

Date: 25.OCT.2006 01:44:22



- Test Mode : PCS (GSM) CH661
- Frequency Range : 1G-3G

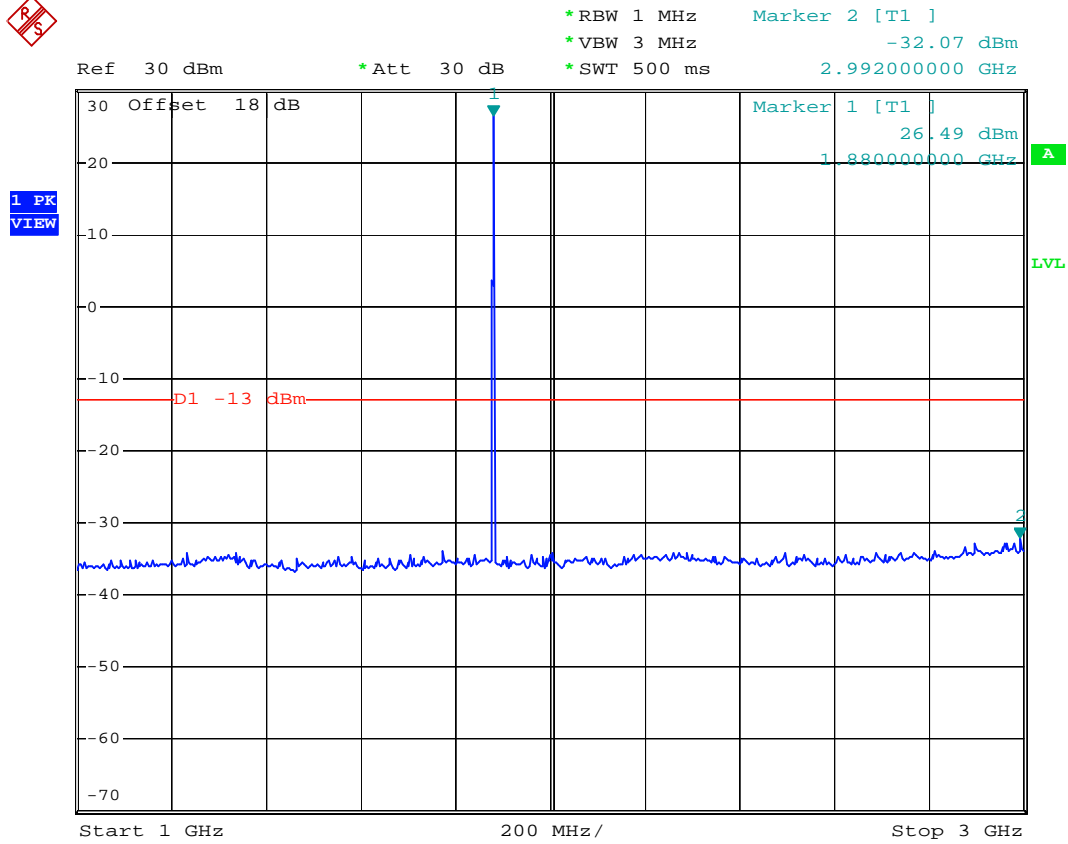

Date: 25.OCT.2006 01:45:32



- Test Mode : PCS (GSM) CH661
- Frequency Range : 3G-7G

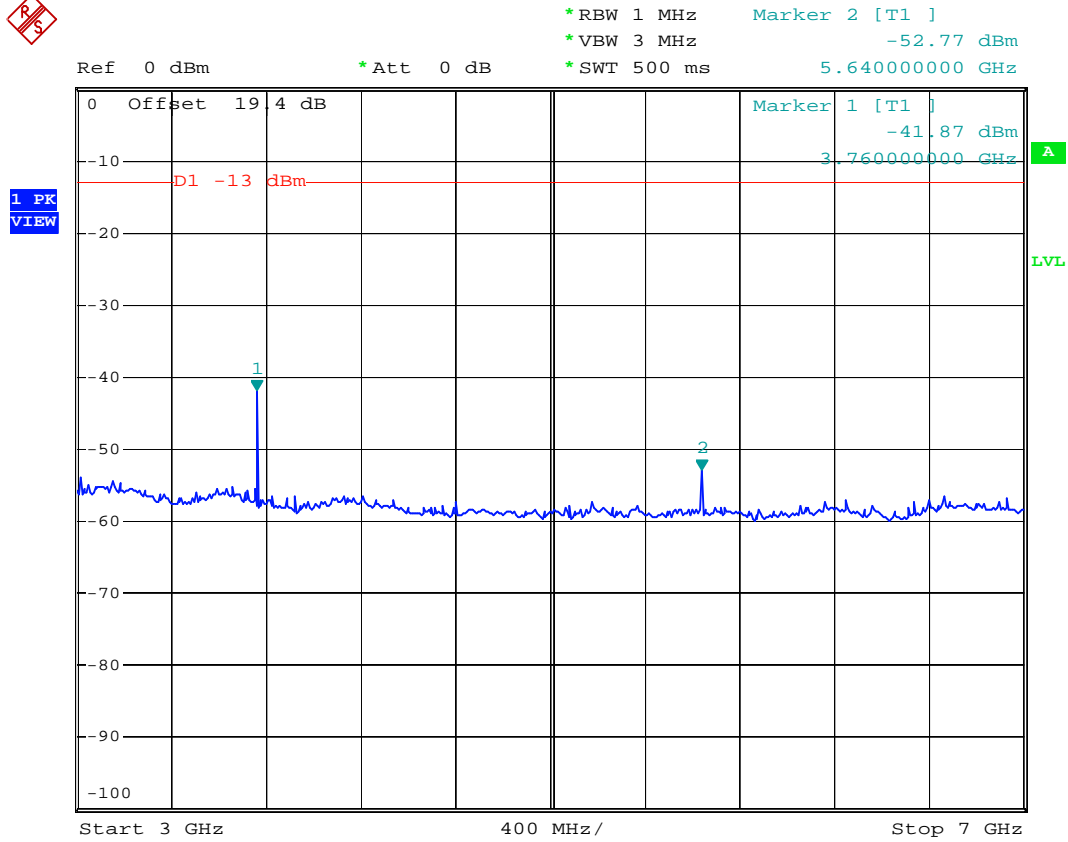

Date: 25.OCT.2006 01:47:00



- Test Mode : PCS (GSM) CH661
- Frequency Range : 7G-13.6G

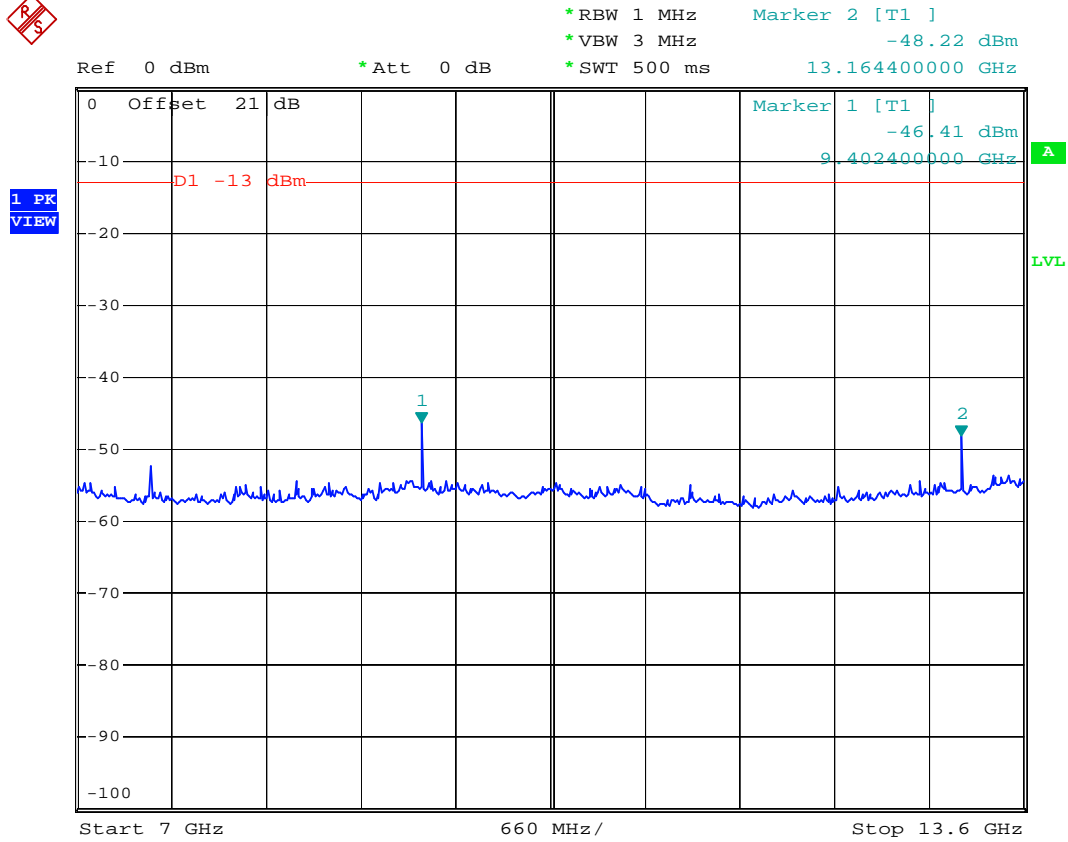

Date: 25.OCT.2006 01:48:24





- Test Mode : PCS (GSM) CH661
- Frequency Range : 13.6G-19.1G

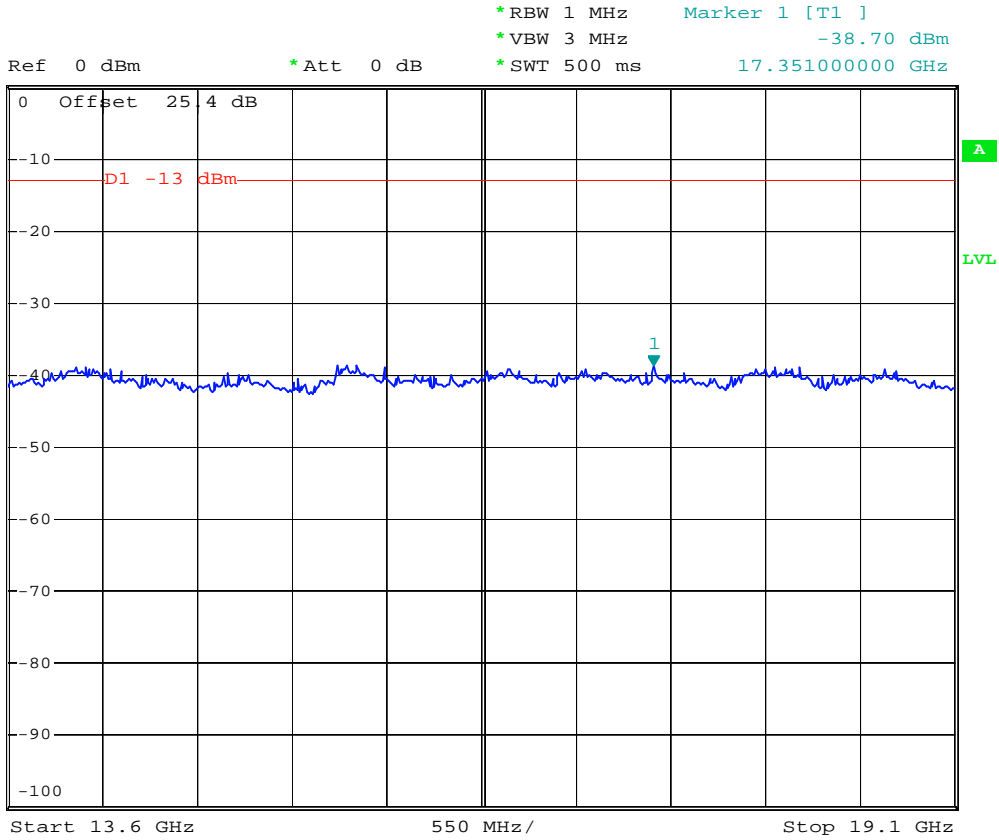

Date: 25.OCT.2006 01:49:18





- Test Mode : PCS (EDGE) CH661
- Frequency Range : 1G-3G

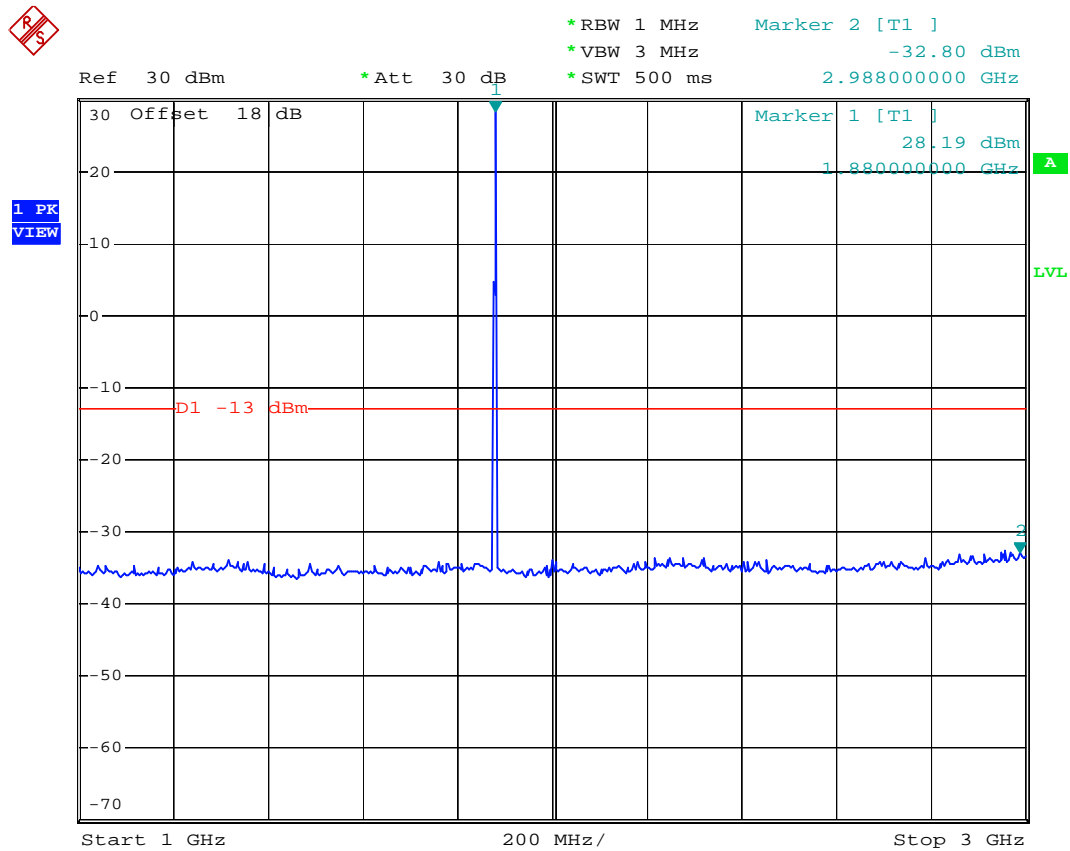

Date: 30.OCT.2006 09:21:13



- Test Mode : PCS (EDGE) CH661
- Frequency Range : 3G-7G

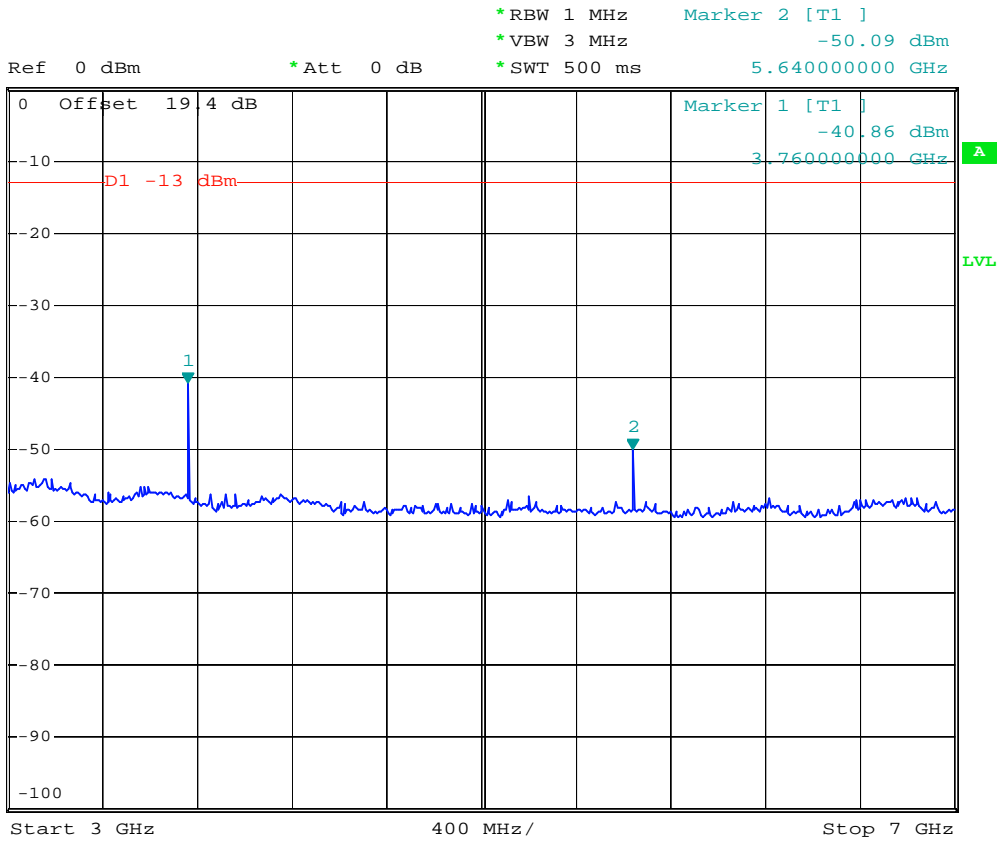

Date: 30.OCT.2006 09:25:00



- Test Mode : PCS (EDGE) CH661
- Frequency Range : 7G-13.6G

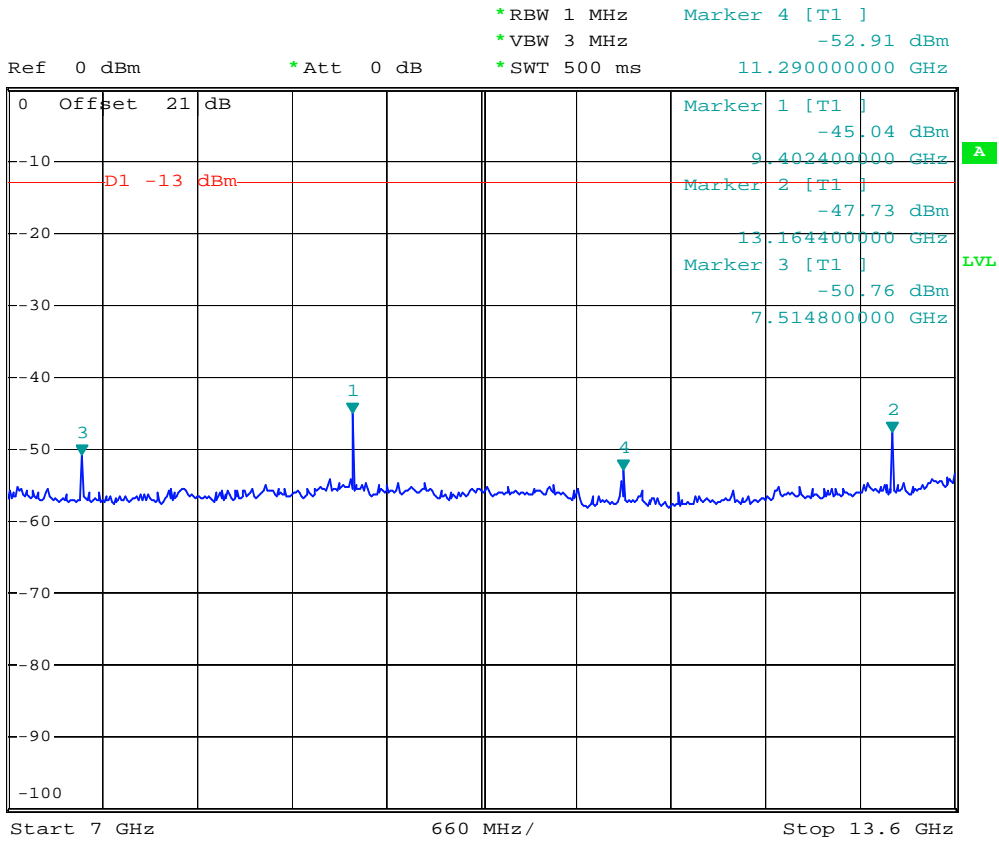

Date: 30.OCT.2006 09:26:03



- Test Mode : PCS (EDGE) CH661
- Frequency Range : 13.6G-19.1G

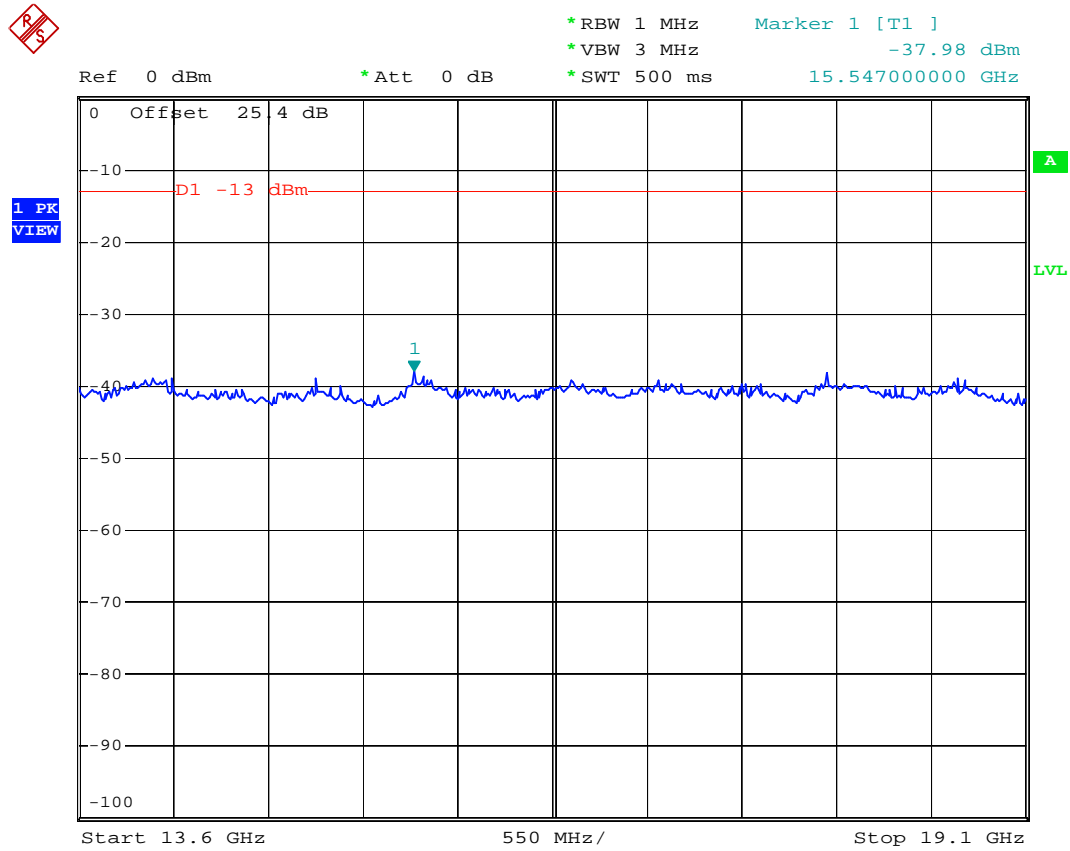

Date: 30.OCT.2006 09:29:12



- Mode 3
- Test Mode : WCDMA Band 2 CH9400
- Frequency Range : 30M-1G

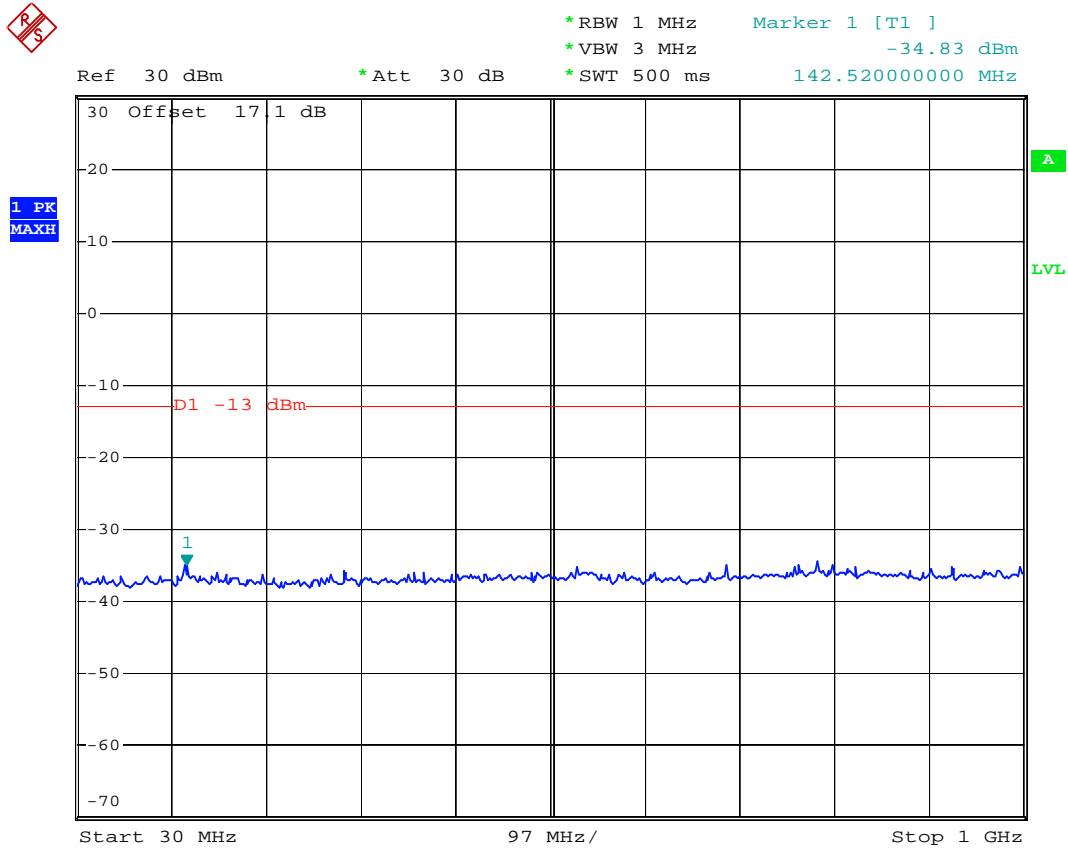

Date: 24.OCT.2006 04:41:55



- Test Mode : WCDMA Band 2 CH9400
- Frequency Range : 1G-3G

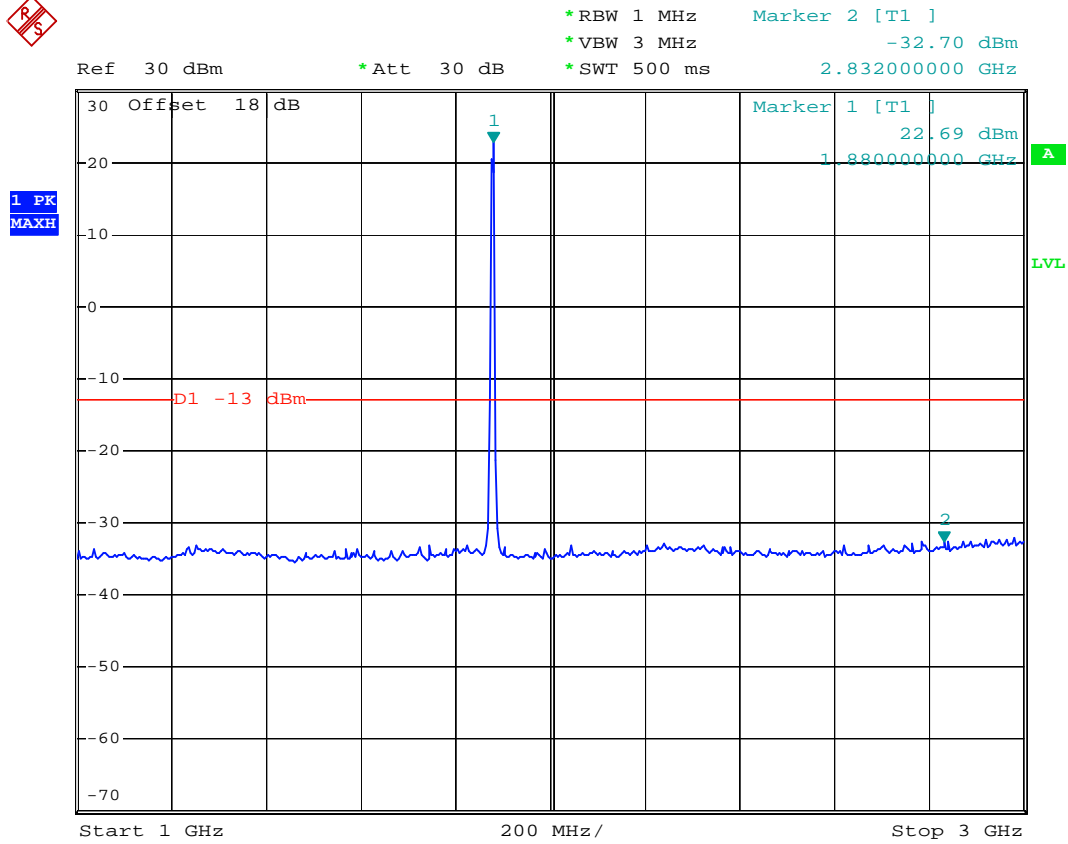

Date: 24.OCT.2006 04:48:49





- Test Mode : WCDMA Band 2 CH9400
- Frequency Range : 3G-7G

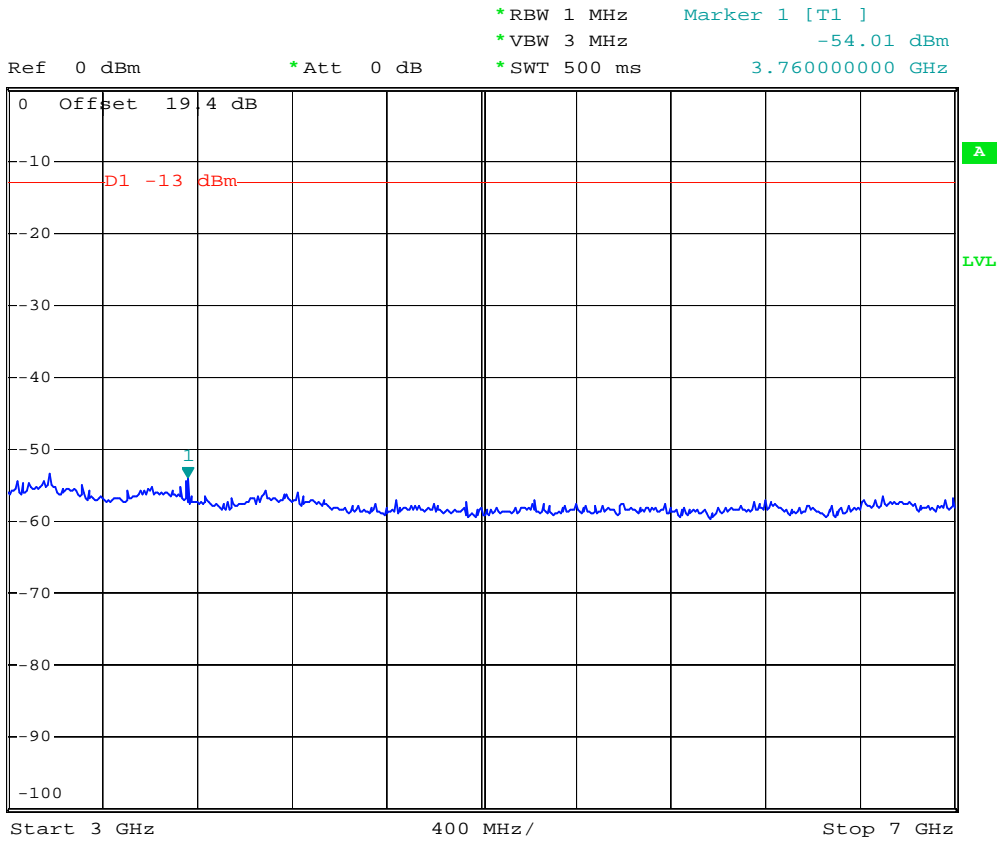

Date: 24.OCT.2006 04:50:54





- Test Mode : WCDMA Band 2 CH9400
- Frequency Range : 13.6G-19.1G

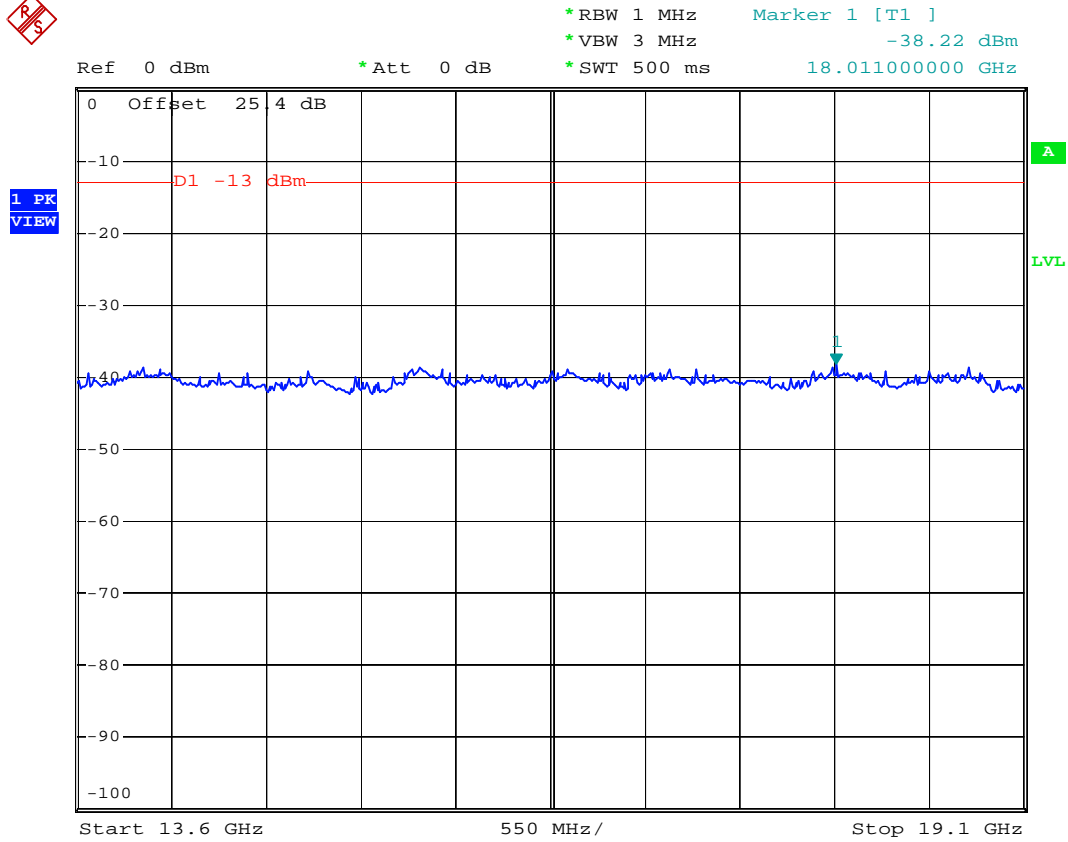

Date: 24.OCT.2006 04:53:58

## 4.6 Field Strength of Spurious Radiation

Equivalent isotropic radiated Power Measurements by substitution method according to ANSI/TIA/EIA-603-A.

### 4.6.1 Measurement Instruments

As described in chapter 5 of this test report.

### 4.6.2 Test Procedure

1. The EUT was placed on a rotatable wooden table with 0.8 meter about ground.
2. The EUT was set 3 meters from the receiving antenna which was mounted on the antenna tower.
3. The table was rotated 360 degrees to determine the position of the highest spurious emission.
4. The height of the receiving antenna is varied between one meter and four meters to reach the maximum spurious emission for both horizontal and vertical polarizations.
5. Taking the record of maximum spurious emission.
6. A Horn antenna was substituted in place of the EUT and was driven by a signal generator.
7. Tune the output power of signal generator to the same emission level with EUT maximum spurious emission.
8. Taking the record of output power at antenna port.
9. Repeat step 7 to step 8 for another polarization.
10. Emission level (dBm) = output power + substitution Gain.

### 4.6.3 Test Setup Layout

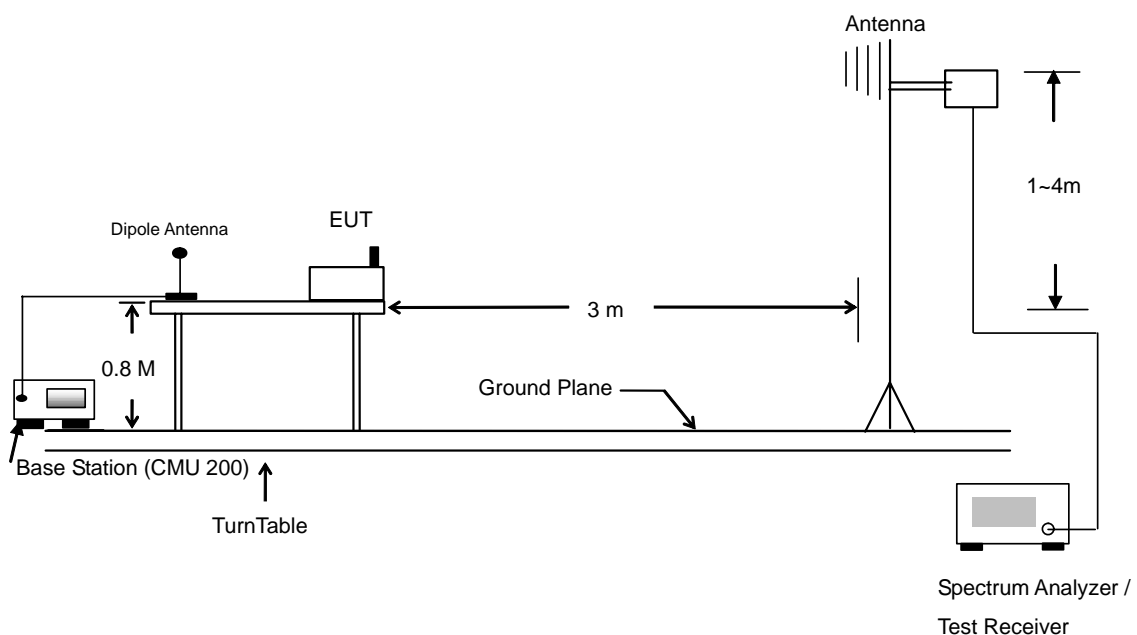



4.6.4 Test Result

- Test Mode : Mode 1

PCS (GSM) Radiated Spurious EIRP							
H Polarization				V Polarization			
Frequency (MHz)	EIRP (dBm)	Limit (dBm)	Margin (dB)	Frequency (MHz)	EIRP (dBm)	Limit (dBm)	Margin (dB)
76.980	-49.860	-13	-36.86	75.090	-44.710	-13	-31.71
153.390	-51.100	-13	-38.10	140.430	-51.500	-13	-38.50
223.590	-52.780	-13	-39.78	162.840	-40.750	-13	-27.75
301.400	-61.610	-13	-48.61	316.800	-56.200	-13	-43.20
378.400	-65.850	-13	-52.85	358.800	-64.530	-13	-51.53
992.300	-63.230	-13	-50.23	854.400	-59.350	-13	-46.35
3758.000	-45.930	-13	-32.93	3758.000	-46.520	-13	-33.52
5638.000	-50.020	-13	-37.02	5638.000	-53.980	-13	-40.98
7518.000	-41.750	-13	-28.75	7518.000	-47.190	-13	-34.19
<b>9398.000</b>	<b>-37.510</b>	<b>-13</b>	<b>-24.51</b>	13158.000	-46.990	-13	-33.99

- Test Mode : Mode 2

PCS (EDGE) Radiated Spurious EIRP							
H Polarization				V Polarization			
Frequency (MHz)	EIRP (dBm)	Limit (dBm)	Margin (dB)	Frequency (MHz)	EIRP (dBm)	Limit (dBm)	Margin (dB)
69.690	-52.320	-13	-39.32	146.640	-47.860	-13	-34.86
163.380	-49.660	-13	-36.66	167.430	-44.990	-13	-31.99
212.790	-55.190	-13	-42.19	223.590	-47.330	-13	-34.33
313.300	-59.190	-13	-46.19	313.300	-55.580	-13	-42.58
372.800	-65.960	-13	-52.96	339.900	-62.550	-13	-49.55
990.900	-63.740	-13	-50.74	938.400	-61.460	-13	-48.46
1708.000	-56.200	-13	-43.20	1554.000	-56.910	-13	-43.91
3758.000	-43.030	-13	-30.03	3758.000	-44.140	-13	-31.14
5638.000	-45.550	-13	-32.55	5638.000	-51.110	-13	-38.11
<b>9398.000</b>	<b>-35.080</b>	<b>-13</b>	<b>-22.08</b>	7518.000	-43.710	-13	-30.71
13158.000	-38.900	-13	-25.90	13158.000	-45.620	-13	-32.62



- Test Mode : Mode 3

WCDMA Band 2 Radiated Spurious EIRP							
H Polarization				V Polarization			
Frequency (MHz)	EIRP (dBm)	Limit (dBm)	Margin (dB)	Frequency (MHz)	EIRP (dBm)	Limit (dBm)	Margin (dB)
76.980	-62.790	-13	-49.79	74.280	-58.140	-13	-45.14
167.430	-59.620	-13	-46.62	162.030	-50.180	-13	-37.18
217.380	-56.690	-13	-43.69	210.630	-60.810	-13	-47.81
301.400	-66.340	-13	-53.34	329.400	-63.850	-13	-50.85
857.900	-64.450	-13	-51.45	763.400	-59.250	-13	-46.25
976.900	-63.750	-13	-50.75	981.800	-61.160	-13	-48.16
<b>4474.000</b>	<b>-49.730</b>	<b>-13</b>	<b>-36.73</b>				



4.6.5 Test Data

4.6.5.1 Mode 1

Horizontal Polarization

	Freq	Level	Over Limit	Limit Line	Read Level	Factor	Remark
	MHz	dBm	dB	dBm	dBm	dB	
1 @	77.0	-49.86	-36.86	-13.00	-37.53	-12.33	Peak
2	153.4	-51.10	-38.10	-13.00	-38.24	-12.85	Peak
3	223.6	-52.78	-39.78	-13.00	-40.23	-12.55	Peak

	Freq	Level	Over Limit	Limit Line	Read Level	Factor	Remark
	MHz	dBm	dB	dBm	dBm	dB	
1	301.4	-61.61	-48.61	-13.00	-51.73	-9.88	Peak
2	378.4	-65.85	-52.85	-13.00	-58.61	-7.24	Peak
3	992.3	-63.23	-50.23	-13.00	-63.40	0.17	Peak

	Freq	Level	Over Limit	Limit Line	Read Level	Factor	Remark
	MHz	dBm	dB	dBm	dBm	dB	
1	1884.0	-50.93			-50.25	-0.68	Peak
2	1958.0	-50.99			-49.88	-1.11	Peak

Remark:

- #1: MS TCH Signal
- #2: BS TCH Signal

	Freq	Level	Over Limit	Limit Line	Read Level	Factor	Remark
	MHz	dBm	dB	dBm	dBm	dB	
1 @	3758.0	-45.93	-32.93	-13.00	-53.85	7.92	Peak

	Freq	Level	Over Limit	Limit Line	Read Level	Factor	Remark
	MHz	dBm	dB	dBm	dBm	dB	
1	5638.0	-50.02	-37.02	-13.00	-59.99	9.97	Peak

	Freq	Level	Over Limit	Limit Line	Read Level	Factor	Remark
	MHz	dBm	dB	dBm	dBm	dB	
1 @	7518.0	-41.75	-28.75	-13.00	-57.56	15.80	Peak

	Freq	Level	Over Limit	Limit Line	Read Level	Factor	Remark
	MHz	dBm	dB	dBm	dBm	dB	
1 @	9398.0	-37.51	-24.51	-13.00	-55.74	18.22	Peak



Vertical Polarization

	Freq	Level	Over Limit	Limit Line	Read Level	Factor	Remark
	MHz	dBm	dB	dBm	dBm	dB	
1 @	75.1	-44.71	-31.71	-13.00	-33.38	-11.32	Peak
2	140.4	-51.50	-38.50	-13.00	-43.44	-8.06	Peak
3 @	162.8	-40.75	-27.75	-13.00	-32.49	-8.26	Peak

	Freq	Level	Over Limit	Limit Line	Read Level	Factor	Remark
	MHz	dBm	dB	dBm	dBm	dB	
1	316.8	-56.20	-43.20	-13.00	-50.11	-6.09	Peak
2	358.8	-64.53	-51.53	-13.00	-59.33	-5.20	Peak
3	854.4	-59.35	-46.35	-13.00	-60.86	1.50	Peak

	Freq	Level	Over Limit	Limit Line	Read Level	Factor	Remark
	MHz	dBm	dB	dBm	dBm	dB	
1	1884.0	-52.76			-52.26	-0.50	Peak
2 @	1958.0	-45.92			-45.33	-0.60	Peak

Remark:

- #1: MS TCH Signal
- #2: BS TCH Signal

	Freq	Level	Over Limit	Limit Line	Read Level	Factor	Remark
	MHz	dBm	dB	dBm	dBm	dB	
1 @	3758.0	-46.52	-33.52	-13.00	-53.16	6.64	Peak

	Freq	Level	Over Limit	Limit Line	Read Level	Factor	Remark
	MHz	dBm	dB	dBm	dBm	dB	
1	5638.0	-53.98	-40.98	-13.00	-62.64	8.65	Peak

	Freq	Level	Over Limit	Limit Line	Read Level	Factor	Remark
	MHz	dBm	dB	dBm	dBm	dB	
1 @	7518.0	-47.19	-34.19	-13.00	-60.56	13.37	Peak

	Freq	Level	Over Limit	Limit Line	Read Level	Factor	Remark
	MHz	dBm	dB	dBm	dBm	dB	
1 @	13158.0	-46.99	-33.99	-13.00	-62.78	15.79	Peak

Remark : There is no more obvious emission except the listings above.





4.6.5.2 Mode 2

Horizontal Polarization

	Freq	Level	Over Limit	Limit Line	Read Level	Factor	Remark
	MHz	dBm	dB	dBm	dBm	dB	
1	69.7	-52.32	-39.32	-13.00	-39.97	-12.36	Peak
2	163.4	-49.66	-36.66	-13.00	-36.68	-12.98	Peak
3	212.8	-55.19	-42.19	-13.00	-42.23	-12.96	Peak

	Freq	Level	Over Limit	Limit Line	Read Level	Factor	Remark
	MHz	dBm	dB	dBm	dBm	dB	
1	313.3	-59.19	-46.19	-13.00	-49.71	-9.48	Peak
2	372.8	-65.96	-52.96	-13.00	-58.52	-7.44	Peak
3	990.9	-63.74	-50.74	-13.00	-63.90	0.16	Peak

	Freq	Level	Over Limit	Limit Line	Read Level	Factor	Remark
	MHz	dBm	dB	dBm	dBm	dB	
1	1708.0	-56.20	-43.20	-13.00	-56.28	0.08	Peak
2	1884.0	-50.30			-49.63	-0.68	Peak
3	1958.0	-47.14			-46.03	-1.11	Peak

Remark:

- 1. #2: MS TCH Signal
- 2. #3: BS TCH Signal

	Freq	Level	Over Limit	Limit Line	Read Level	Factor	Remark
	MHz	dBm	dB	dBm	dBm	dB	
1 @	3758.0	-43.03	-30.03	-13.00	-50.95	7.92	Peak

	Freq	Level	Over Limit	Limit Line	Read Level	Factor	Remark
	MHz	dBm	dB	dBm	dBm	dB	
1 @	5638.0	-45.55	-32.55	-13.00	-55.52	9.97	Peak

	Freq	Level	Over Limit	Limit Line	Read Level	Factor	Remark
	MHz	dBm	dB	dBm	dBm	dB	
1 @	9398.0	-35.08	-22.08	-13.00	-53.30	18.22	Peak

	Freq	Level	Over Limit	Limit Line	Read Level	Factor	Remark
	MHz	dBm	dB	dBm	dBm	dB	
1 @	13158.0	-38.90	-25.90	-13.00	-57.61	18.71	Peak



Vertical Polarization

	Freq	Level	Over Limit	Limit Line	Read Level	Factor	Remark
	MHz	dBm	dB	dBm	dBm	dB	
1	146.6	-47.86	-34.86	-13.00	-39.75	-8.11	Peak
2 @	167.4	-44.99	-31.99	-13.00	-36.69	-8.30	Peak
3	223.6	-47.33	-34.33	-13.00	-39.26	-8.07	Peak

	Freq	Level	Over Limit	Limit Line	Read Level	Factor	Remark
	MHz	dBm	dB	dBm	dBm	dB	
1	313.3	-55.58	-42.58	-13.00	-49.41	-6.17	Peak
2	339.9	-62.55	-49.55	-13.00	-56.94	-5.61	Peak
3	938.4	-61.46	-48.46	-13.00	-63.63	2.17	Peak

	Freq	Level	Over Limit	Limit Line	Read Level	Factor	Remark
	MHz	dBm	dB	dBm	dBm	dB	
1	1554.0	-56.91	-43.91	-13.00	-56.21	-0.70	Peak
2	1884.0	-52.68			-52.18	-0.50	Peak
3	1958.0	-53.57			-52.97	-0.60	Peak

Remark:

- 1. #2: MS TCH Signal
- 2. #3: BS TCH Signal

	Freq	Level	Over Limit	Limit Line	Read Level	Factor	Remark
	MHz	dBm	dB	dBm	dBm	dB	
1 @	3758.0	-44.14	-31.14	-13.00	-50.78	6.64	Peak

	Freq	Level	Over Limit	Limit Line	Read Level	Factor	Remark
	MHz	dBm	dB	dBm	dBm	dB	
1	5638.0	-51.11	-38.11	-13.00	-59.76	8.65	Peak

	Freq	Level	Over Limit	Limit Line	Read Level	Factor	Remark
	MHz	dBm	dB	dBm	dBm	dB	
1 @	7518.0	-43.71	-30.71	-13.00	-57.08	13.37	Peak

	Freq	Level	Over Limit	Limit Line	Read Level	Factor	Remark
	MHz	dBm	dB	dBm	dBm	dB	
1 @	840.40	-39.32	-26.32	-13.00	-38.02	-1.31	Peak
2 @	880.30	-42.37	-29.37	-13.00	-41.46	-0.91	Peak
3 @	901.30	-62.53	-49.53	-13.00	-61.82	-0.72	Peak

Remark : There is no more obvious emission except the listings above.



4.6.5.3 Mode 3  
Horizontal Polarization

	Freq	Level	Over Limit	Limit Line	Read Level	Factor	Remark
	MHz	dBm	dB	dBm	dBm	dB	
1 @	77.0	-62.79	-49.79	-13.00	-50.47	-12.33	Peak
2 @	167.4	-59.62	-46.62	-13.00	-46.60	-13.02	Peak
3 @	217.4	-56.69	-43.69	-13.00	-43.91	-12.79	Peak

	Freq	Level	Over Limit	Limit Line	Read Level	Factor	Remark
	MHz	dBm	dB	dBm	dBm	dB	
1 @	301.4	-66.34	-53.34	-13.00	-56.47	-9.88	Peak
2 @	857.9	-64.45	-51.45	-13.00	-63.32	-1.13	Peak
3 @	976.9	-63.75	-50.75	-13.00	-63.77	0.02	Peak

	Freq	Level	Over Limit	Limit Line	Read Level	Factor	Remark
	MHz	dBm	dB	dBm	dBm	dB	
1 @	1878.0	-21.94			-21.43	-0.51	Peak
2 @	1958.0	-45.35			-44.24	-1.11	Peak

Remark:

- 1. #1: MS TCH Signal
- 2. #2: BS TCH Signal

	Freq	Level	Over Limit	Limit Line	Read Level	Factor	Remark
	MHz	dBm	dB	dBm	dBm	dB	
1 @	4474.0	-49.73	-36.73	-13.00	-60.13	10.41	Peak



Vertical Polarization

	Freq	Level	Over Limit	Limit Line	Read Level	Factor	Remark
	MHz	dBm	dB	dBm	dBm	dB	
1 @	74.3	-58.14	-45.14	-13.00	-46.82	-11.32	Peak
2 @	162.0	-50.18	-37.18	-13.00	-41.93	-8.25	Peak
3 @	210.6	-60.81	-47.81	-13.00	-52.44	-8.36	Peak

	Freq	Level	Over Limit	Limit Line	Read Level	Factor	Remark
	MHz	dBm	dB	dBm	dBm	dB	
1 @	329.4	-63.85	-50.85	-13.00	-58.03	-5.82	Peak
2 @	763.4	-59.25	-46.25	-13.00	-59.77	0.52	Peak
3 @	981.8	-61.16	-48.16	-13.00	-63.68	2.51	Peak

	Freq	Level	Over Limit	Limit Line	Read Level	Factor	Remark
	MHz	dBm	dB	dBm	dBm	dB	
1 @	1878.0	-29.52			-29.12	-0.40	Peak
2 @	1958.0	-39.07			-38.47	-0.60	Peak

Remark:

- #1: MS Signal
- #2: BS Signal

Remark: There is no more obvious emission except the listings above.

## 4.7 Frequency Stability (Temperature Variation)

### 4.7.1 Measurement Instrument

As described in chapter 5 of this test report.

### 4.7.2 Test Procedure

1. The EUT and test equipment were set up as shown on the following section.
2. With all power removed, the temperature was decreased to  $-30^{\circ}\text{C}$  and permitted to stabilize for three hours. Power was applied and the maximum change in frequency was noted within one minute.
3. With power OFF, the temperature was raised in  $10^{\circ}\text{C}$  steps. The sample was permitted to stabilize at each step for at least one-half hour. Power was applied and the maximum frequency change was noted within one minute.
4. The temperature tests were performed for the worst case.
5. Test data was recorded.

### 4.7.3 Test Setup Layout

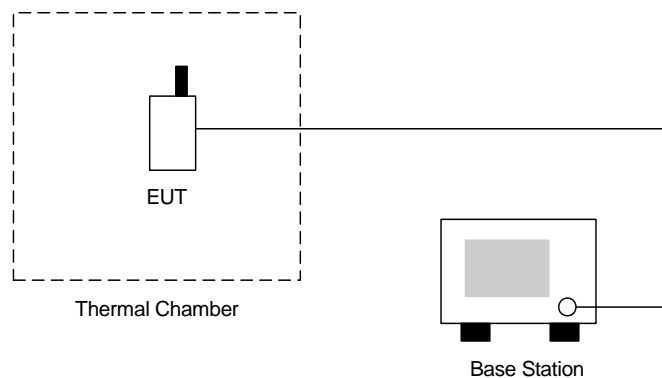



4.7.4 Test Result

- Test Mode : PCS (GSM) CH661

Temperature(°C)	Change (Hz)	Change (ppm)	Limit (ppm)	Result
-30	-40	-0.02	2.5	Passed
-20	-33	-0.02		
-10	28	0.01		
0	-34	-0.02		
10	41	0.02		
20	33	0.02		
30	35	0.02		
40	-38	-0.02		
50	-20	-0.01		

- Test Mode : WCDMA Band 2 CH9400

Temperature(°C)	Change (Hz)	Change (ppm)	Limit (ppm)	Result
-30	-36.00	-0.02	2.5	Passed
-20	-42.00	-0.02		
-10	-40.00	-0.02		
0	36.00	0.02		
10	33.00	0.02		
20	43.00	0.02		
30	-46.00	-0.02		
40	-42.00	-0.02		
50	-24.00	-0.01		

## 4.8 Frequency Stability (Voltage Variation)

### 4.8.1 Measurement Instrument

As described in chapter 5 of this test report.

### 4.8.2 Test Procedure

1. The EUT was placed in a temperature chamber at  $25\pm 5^{\circ}\text{C}$  and connected as the following section.
2. The power supply voltage to the EUT was varied from BEP to 115% of the nominal value measured at the input to the EUT.
3. The variation in frequency was measured for the worst case.

### 4.8.3 Test Setup Layout

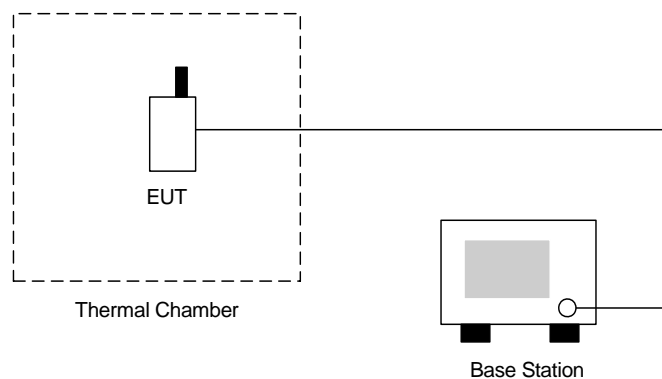



4.8.4 Test Result

- Test Mode : PCS (GSM) CH661

Voltage(Volt)	Change (Hz)	Change (ppm)	Limit (ppm)	Result
3.7	33.0	0.02	2.5	Passed
BEP	-48.0	-0.03		
4.2	38.0	0.02		

- Test Mode : WCDMA Band 2 CH9400

Voltage(Volt)	Change (Hz)	Change (ppm)	Limit (ppm)	Result
3.7	-47.0	-0.02	2.5	Passed
BEP	-48.0	-0.03		
4.2	41.0	0.02		

Remark:

1. Normal Voltage=3.7V.
2. Battery End Point (BEP)=3.4 V.





## 5 List of Measurement Equipments

Instrument	Manufacturer	Model No.	Serial No.	Characteristics	Calibration Date	Due Date	Remark
Spectrum analyzer	Agilent	E4408B	MY44211030	9KHz-26.5GHz	Jul. 25, 2006	Jul. 24, 2007	Radiation (03CH06-HY)
Receiver	R&S	ESCS30	100356	9KHz-2.75GHz	Jun. 26, 2006	Jun. 25, 2007	Radiation (03CH06-HY)
Controller	CT	SC100	N/A	N/A	N/A	N/A	Radiation (03CH06-HY)
Bilog Antenna	SCHAFFNER	CBL6112B	2885	30MHz -2GHz	Nov. 21, 2004	Nov. 20, 2006	Radiation (03CH06-HY)
Horn Antenna	Com-Power	AH118	071025	1G-18G	Feb. 1, 2005	Jan. 31, 2007	Radiation (03CH06-HY)
SHF-EHF Horn	SCHWARZBECK	BBHA 9170	9170-249	14G - 40G	Jul. 21, 2006	Jul. 20, 2007	Radiation (03CH06-HY)
HF Amplifier	MITEQ	AFS44	973248	0.1G - 26.5G	Dec. 17, 2005	Dec. 17, 2006	Radiation (03CH06-HY)
Amplifier	MITEQ	AMF-6F	997165	26G - 40G	Jul. 21, 2006	Jul. 20, 2007	Radiation (03CH06-HY)
Turn Table	HD	DS 420	420/650/00	0 ~ 360 degree	N/A	N/A	Radiation (03CH06-HY)
Antenna Mast	HD	MA 240	240/560/00	1 m - 4 m	N/A	N/A	Radiation (03CH06-HY)



## 6 Uncertainty Evaluation

### Uncertainty of Radiated Emission Measurement (30MHz ~ 1000MHz)

Contribution	Uncertainty of $x_i$		$u(x_i)$
	dB	Probability Distribution	
Receiver reading	0.41	Normal(k=2)	0.21
Antenna factor calibration	0.83	Normal(k=2)	0.42
Cable loss calibration	0.25	Normal(k=2)	0.13
Pre Amplifier Gain calibration	0.27	Normal(k=2)	0.14
RCV/SPA specification	2.50	Rectangular	0.72
Antenna Factor Interpolation for Frequency	1.00	Rectangular	0.29
Site imperfection	1.43	Rectangular	0.83
Mismatch	+0.39/-0.41	U-shaped	0.28
<b>combined standard uncertainty Uc(y)</b>	<b>1.27</b>		
<b>Measuring uncertainty for a level of confidence of 95% U=2Uc(y)</b>	<b>2.54</b>		

### Uncertainty of Radiated Emission Measurement (1GHz ~ 40GHz)

Contribution	Uncertainty of $x_i$		$u(x_i)$	$C_i$	$C_i * u(x_i)$
	dB	Probability Distribution			
Receiver reading	±0.10	Normal(k=1)	0.10	1	0.10
Antenna factor calibration	±1.70	Normal(k=2)	0.85	1	0.85
Cable loss calibration	±0.50	Normal(k=2)	0.25	1	0.25
Receiver Correction	±2.00	Rectangular	1.15	1	1.15
Antenna Factor Directional	±1.50	Rectangular	0.87	1	0.87
Site imperfection	±2.80	Triangular	1.14	1	1.14
Mismatch Receiver VSWR $\Gamma_1 = 0.197$ Antenna VSWR $\Gamma_2 = 0.194$ Uncertainty = $20 \log(1 - \Gamma_1 * \Gamma_2 * \Gamma_3)$	+0.34/-0.35	U-shaped	0.244	1	0.244
<b>Combined standard uncertainty Uc(y)</b>	<b>2.36</b>				
<b>Measuring uncertainty for a level of confidence of 95% U=2Ue(y)</b>	<b>4.72</b>				

END OF TEST REPORT