



# FCC TEST REPORT

**REPORT NO.:** RF920218H04

**MODEL NO.:** WN4401

**RECEIVED:** Feb. 18, 2003

**TESTED:** Mar. 01 to 19, 2003

**APPLICANT:** Accton Technology Corporation

**ADDRESS:** No.1, Creation Rd. III, Science-based Industrial Park, Hsinchu, Taiwan, R.O.C

**ISSUED BY:** Advance Data Technology Corporation

**LAB LOCATION:** No. 81-1, Lu Liao Keng, 9 Ling, Wu Lung Tsuen, Chiung Lin Hsiang, Hsin Chu Hsien, Taiwan, R.O.C.

This test report consists of 128 pages in total. It may be duplicated completely for legal use with the approval of the applicant. It should not be reproduced except in full, without the written approval of our laboratory. The client should not use it to claim product endorsement by CNLA, NVLAP or any government agencies. The test results in the report only apply to the tested sample.



0536  
ILAC MRA



Lab Code: 200376-0



## Table of Contents

1	CERTIFICATION.....	5
2	SUMMARY OF TEST RESULTS.....	6
3	GENERAL INFORMATION .....	7
3.1	GENERAL DESCRIPTION OF EUT.....	7
3.2	DESCRIPTION OF TEST MODES.....	8
3.3	GENERAL DESCRIPTION OF APPLIED STANDARDS .....	8
3.4	DESCRIPTION OF SUPPORT UNITS.....	9
4	TEST TYPES AND RESULTS .....	10
4.1	CONDUCTED EMISSION MEASUREMENT.....	10
4.1.1	LIMITS OF CONDUCTED EMISSION MEASUREMENT.....	10
4.1.2	TEST INSTRUMENTS .....	10
4.1.3	TEST SETUP .....	11
4.1.4	EUT OPERATING CONDITIONS .....	12
4.1.5	TEST RESULTS.....	13
4.2	RADIATED EMISSION MEASUREMENT .....	19
4.2.1	LIMITS OF RADIATED EMISSION MEASUREMENT.....	19
4.2.2	TEST INSTRUMENTS .....	20
4.2.3	TEST PROCEDURES .....	21
4.2.4	TEST SETUP .....	22
4.2.5	EUT OPERATING CONDITIONS .....	22
4.2.6	TEST RESULTS (A).....	23
4.2.7	TEST RESULTS (A) - DSSS .....	24
4.2.8	TEST RESULTS (A) -OFDM.....	27
4.2.9	TEST RESULTS (B).....	30
4.2.10	TEST RESULTS (B) - DSSS .....	31
4.2.11	TEST RESULTS (B) -OFDM.....	34
4.2.12	TEST RESULTS (C).....	37
4.2.13	TEST RESULTS (C) - DSSS .....	38
4.2.14	TEST RESULTS (C) -OFDM.....	41
4.3	6dB BANDWIDTH MEASUREMENT .....	44
4.3.1	LIMITS OF 6dB BANDWIDTH MEASUREMENT.....	44
4.3.2	TEST INSTRUMENTS .....	44
4.3.3	TEST PROCEDURE .....	45
4.3.4	TEST SETUP .....	45
4.3.5	EUT OPERATING CONDITIONS .....	45



4.3.6	TEST RESULTS(A)-DSSS.....	46
4.3.7	TEST RESULTS(A)-OFDM.....	50
4.3.8	TEST RESULTS(B)-DSSS.....	54
4.3.9	TEST RESULTS(B)-OFDM.....	58
4.3.10	TEST RESULTS(C)-DSSS.....	62
4.3.11	TEST RESULTS(C)-OFDM.....	66
4.4	MAXIMUM PEAK OUTPUT POWER .....	70
4.4.1	LIMITS OF MAXIMUM PEAK OUTPUT POWER MEASUREMENT .....	70
4.4.2	TEST INSTRUMENTS .....	70
4.4.3	TEST PROCEDURES .....	71
4.4.4	TEST SETUP .....	71
4.4.5	EUT OPERATING CONDITIONS .....	71
4.4.6	TEST RESULTS(A)-DSSS.....	72
4.4.7	TEST RESULTS(A)-OFDM.....	72
4.4.8	TEST RESULTS(B)-DSSS.....	73
4.4.9	TEST RESULTS(B)-OFDM.....	73
4.4.10	TEST RESULTS(C)-DSSS.....	74
4.4.11	TEST RESULTS(C)-OFDM.....	74
4.5	POWER SPECTRAL DENSITY MEASUREMENT .....	75
4.5.1	LIMITS OF POWER SPECTRAL DENSITY MEASUREMENT.....	75
4.5.2	TEST INSTRUMENTS .....	75
4.5.3	TEST PROCEDURE .....	76
4.5.4	TEST SETUP .....	76
4.5.5	EUT OPERATING CONDITIONS .....	76
4.5.6	TEST RESULTS(A)-DSSS.....	77
4.5.7	TEST RESULTS(A)-OFDM.....	81
4.5.8	TEST RESULTS(B)-DSSS.....	85
4.5.9	TEST RESULTS(B)-OFDM.....	89
4.5.10	TEST RESULTS(C)-DSSS.....	93
4.5.11	TEST RESULTS(C)-OFDM.....	97
4.6	BAND EDGES MEASUREMENT.....	101
4.6.1	LIMITS OF BAND EDGES MEASUREMENT.....	101
4.6.2	TEST INSTRUMENTS .....	101
4.6.3	TEST PROCEDURE .....	101
4.6.4	EUT OPERATING CONDITION.....	101



4.6.5	TEST RESULTS (A)-DSSS.....	102
4.6.6	TEST RESULTS(A)-OFDM.....	105
4.6.7	TEST RESULTS (B)-DSSS.....	108
4.6.8	TEST RESULTS(B)-OFDM.....	111
4.6.9	TEST RESULTS (C)-DSSS .....	114
4.6.10	TEST RESULTS(C)-OFDM.....	117
4.7	ANTENNA REQUIREMENT.....	120
4.7.1	STANDARD APPLICABLE.....	120
4.7.2	ANTENNA CONNECTED CONSTRUCTION .....	120
5	PHOTOGRAPHS OF THE TEST CONFIGURATION.....	121
6	INFORMATION ON THE TESTING LABORATORIES.....	128



## 1 CERTIFICATION

**PRODUCT :** IEEE 802.11g miniPCI  
**BRAND NAME :** Accton  
**MODEL NO. :** WN4401  
**APPLICANT :** Accton Technology Corporation  
**STANDARDS :** 47 CFR Part 15, Subpart C (Section 15.247),  
ANSI C63.4-1992

We, **Advance Data Technology Corporation**, hereby certify that one sample of the designation has been tested in our facility from Mar. 01 to 19, 2003. The test record, data evaluation and Equipment Under Test (EUT) configurations represented herein are true and accurate accounts of the measurements of the sample's EMC characteristics under the conditions herein specified.

**CHECKED BY:** Amanda Chu , **DATE:** Mar. 20, 2003  
( Amanda Chu )

**APPROVED BY:** Eric Lin , **DATE:** Mar. 20, 2003  
( Eric Lin, Manager )



## 2 SUMMARY OF TEST RESULTS

The EUT has been tested according to the following specifications:

<b>APPLIED STANDARD: 47 CFR Part 15, Subpart C</b>			
<b>Standard Section</b>	<b>Test Type and Limit</b>	<b>Result</b>	<b>REMARK</b>
15.207	AC Power Conducted Emission Limit: 48dBuV	PASS	Meet the requirement of limit Minimum passing margin is -13.88 dBuV at 0.318 MHz
15.247(a)(2)	Spectrum Bandwidth of a Direct Sequence Spread Spectrum System Limit: min. 500kHz	PASS	Meet the requirement of limit
15.247(b)	Maximum Peak Output Power Limit: max. 30dBm	PASS	Meet the requirement of limit
15.247(c)	Transmitter Radiated Emissions Limit: Table 15.209	PASS	Meet the requirement of limit Minimum passing margin is -1.7 dBuV at 4874.00MHz
15.247(d)	Power Spectral Density Limit: max. 8dBm	PASS	Meet the requirement of limit
15.247(c)	Band Edge Measurement Limit: 20 dB less than the peak value of fundamental frequency	PASS	Meet the requirement of limit



### 3 GENERAL INFORMATION

#### 3.1 GENERAL DESCRIPTION OF EUT

<b>PRODUCT</b>	IEEE 802.11g miniPCI
<b>MODEL NO.</b>	WN4401
<b>POWER SUPPLY</b>	3.3VDC from host equipment
<b>MODULATION TYPE</b>	CCK, OFDM, DBPSK, DQPSK
<b>RADIO TECHNOLOGY</b>	DSSS, OFDM
<b>TRANSFER RATE</b>	1/2/5.5/6/9/11/12/18/24/36/48/54Mbps
<b>FREQUENCY RANGE</b>	2412MHz ~ 2462MHz
<b>NUMBER OF CHANNEL</b>	11
<b>OUTPUT POWER (DSSS)</b>	17.86dBm
<b>OUTPUT POWER (OFDM)</b>	18.10dBm
<b>ANTENNA TYPE</b>	Dipole Antenna
<b>DATA CABLE</b>	NA
<b>I/O PORTS</b>	NA
<b>ASSOCIATED DEVICES</b>	NA

**NOTE:**

1. There are three types of antennas provided to this EUT, please refer to the following table:

<b>No.</b>	<b>Model No.</b>	<b>Gain (dBi)</b>	<b>Antenna Type / Connector</b>
1	C-1566225	2.0	Dipole Antenna / UFL connector
2	C001-510333	1.8	Dipole Antenna / Integral connector
3	C001-510332	1.8	Dipole Antenna / Integral connector

2. The EUT operates in the 2.4GHz frequency spectrum with throughput of up to 54Mbps.
3. The EUT complies with IEEE 802.11g draft standards, and backwards compatible with IEEE 802.11b products.
4. For a more detailed features description, please refer to the manufacturer's specifications or User's Manual.



### 3.2 DESCRIPTION OF TEST MODES

Eleven channels are provided in this EUT.

Channel	Frequency	Channel	Frequency
1	2412 MHz	7	2442 MHz
2	2417 MHz	8	2447 MHz
3	2422 MHz	9	2452 MHz
4	2427 MHz	10	2457 MHz
5	2432 MHz	11	2462 MHz
6	2437 MHz		

**NOTE:**

1. Below 1 GHz, the channel 1, 6, and 11 were pre-tested in chamber. The channel 11, worst case one, was chosen for final test.
2. Above 1 GHz, the channel 1, 6, and 11 were tested individually.
3. Test result (A) is for antenna 1, test result (B) is for antenna 2 and test result (C) is for antenna 3, which were mentioned on section 3.1.
4. Transfer rate, 11Mbps with CCK technique and 54Mbps with OFDM technique, the worst case, were chosen for final test.

### 3.3 GENERAL DESCRIPTION OF APPLIED STANDARDS

The EUT is a IEEE 802.11g miniPCI. According to the specifications of the manufacturer, it must comply with the requirements of the following standards:

**FCC CFR 47 Part 15, Subpart C. (15.247)**

**ANSI C63.4 : 1992**

All tests have been performed and recorded as per the above standards.

**NOTE:** The EUT is also considered as a kind of computer peripheral, because the connection to computer is necessary for typical use. It has been verified to comply with the requirements of FCC Part 15, Subpart B, Class B (DoC). The test report has been issued separately.





### 3.4 DESCRIPTION OF SUPPORT UNITS

The EUT has been tested as an independent unit together with other necessary accessories or support units. The following support units or accessories were used to form a representative test configuration during the tests.

No.	Product	Brand	Model No.	Serial No.	FCC ID
1	PERSONAL COMPUTER	HP	Brio BA410	SG10602726	FCC DoC
2	MONITOR	ADI	CM100	026058T10200531	FCC DoC
3	PRINTER	HP	C2642A	MY7961C1FQ	B94C2642X
4	MODEM	ACEEX	1414	0206026776	IFAXDM1414
5	KEYBOARD	HP	6511-PK	99P468101CY1W0 1S002170	FCC DoC
6	MOUSE	IBM	M-SAU-IBM6	23-225152	JNZ211220

No.	Signal cable description
1	NA
2	1.8 m braid shielded wire, terminated with VGA connector via metallic frame, w/o core.
3	1.8m braid shielded wire, terminated with DB25 and Centronics connector via metallic frame, w/o core
4	1.3 m braid shielded wire, terminated with DB25 and DB9 connector via metallic frame, w/o core.
5	1.8 m foil shielded wire, terminal by frame, PS2 Connector, w/o Core.
6	1.9 m foil shielded wire, terminal by frame, PS2 Connector, w/o Core.

Note: 1. All power cords of the above support units are unshielded (1.8m).

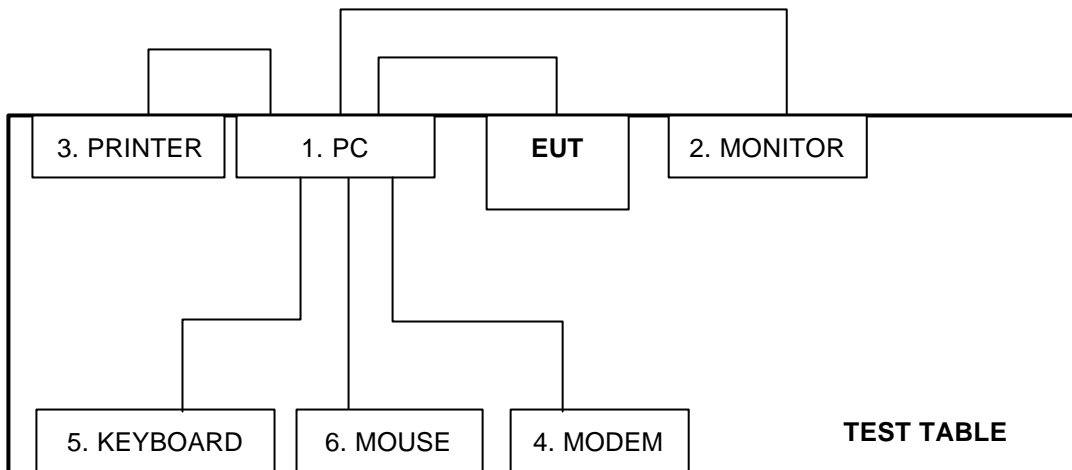

**NOTE:** 1. Please refer to the photos of test configuration in Item 5 also.



## 4 TEST TYPES AND RESULTS

### 4.1 CONDUCTED EMISSION MEASUREMENT

#### 4.1.1 LIMITS OF CONDUCTED EMISSION MEASUREMENT

FREQUENCY OF EMISSION (MHz)	CONDUCTED LIMIT (dB $\mu$ V)	
	Quasi-peak	Average
0.15-0.5	66 to 56	56 to 46
0.5-5	56	46
5-30	60	50

#### NOTE

1. The lower limit shall apply at the transition frequencies.
2. All emanations from a class B digital device or system, including any network of conductors and apparatus connected thereto, shall not exceed the level of field strengths specified above.

#### 4.1.2 TEST INSTRUMENTS

DESCRIPTION & MANUFACTURER	MODEL NO.	SERIAL NO.	CALIBRATION DATE
ROHDE & SCHWARZ Test Receiver	ESCS 30	847124/029	Nov. 17, 2003
ROHDE & SCHWARZ LISN (for EUT)	ESHS-Z5	848773/004	Nov. 13, 2003
KYORITSU LISN (for peripheral)	KNW-407	8/1395/12	Jul. 23, 2003
RF Cable (JETBAO)	RG233/U	Cable_CA_01	Jul. 03, 2003
Terminator(for KYORITSU)	50	#1	Apr. 11, 2003
Software	Cond-V2e	NA	NA

- NOTE: 1. The calibration interval of the above test instruments is 12 months and the calibrations are traceable to NML/ROC and NIST/USA.
2. The test was performed in ADT Shielded Room No. A.
3. The VCCI Con A Registration No. is C-817.

### 3. TEST PROCEDURES

- The EUT was placed 0.4 meters from the conducting wall of the shielded room with EUT being connected to the power mains through a line impedance stabilization network (LISN). Other support units were connected to the power mains through another LISN. The two LISNs provide 50 ohm/ 50uH of coupling impedance for the measuring instrument.
- Both lines of the power mains connected to the EUT were checked for maximum conducted interference.
- The frequency range from 150 kHz to 30 MHz was searched. Emission levels over 10dB under the prescribed limits could not be reported

#### 4.1.3 TEST SETUP

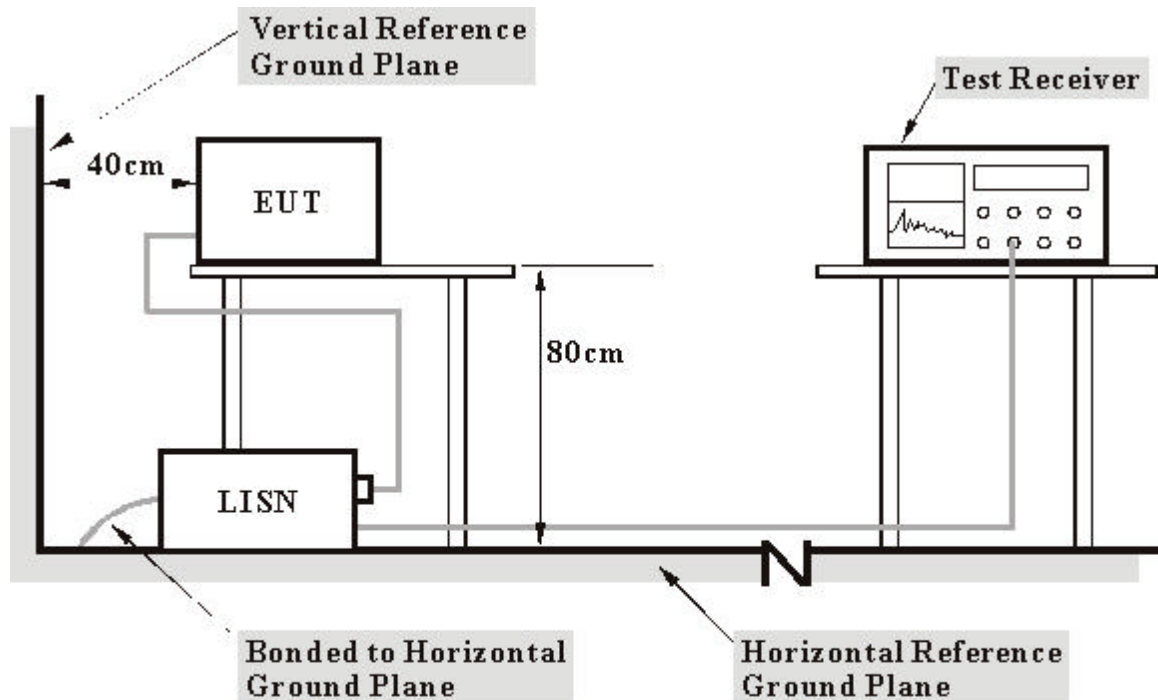

- Note:**
- Support units were connected to second LISN.
  - Both of LISNs (AMN) 80 cm from EUT and at the least 80 cm from other units and other metal planes support units.

For the actual test configuration, please refer to the related item – Photographs of the Test Configuration.



#### 4.1.4 EUT OPERATING CONDITIONS

- a. Connected the EUT to support unit 1 (Personal Computer) and placed on a testing table.
- b. The Personal Computer ran a test program (provided by manufacturer) to enable EUT under transmission condition continuously at specific channel frequency.



4.1.5 TEST RESULTS

<b>EUT</b>	IEEE 802.11g miniPCI	<b>MODEL</b>	WN4401
<b>MODE</b>	Channel 1	<b>6dB BANDWIDTH</b>	9 kHz
<b>INPUT POWER (SYSTEM)</b>	120Vac, 60 Hz	<b>PHASE</b>	Line (L)
<b>ENVIRONMENTAL CONDITIONS</b>	20 deg. C, 60%RH, 979 hPa	<b>TESTED BY</b>	Mike Hsieh

No	Freq. [MHz]	Corr. Factor (dB)	Reading Value [dB (uV)]		Emission Level [dB (uV)]		Limit [dB (uV)]		Margin (dB)	
			Q.P.	AV.	Q.P.	AV.	Q.P.	AV.	Q.P.	AV.
1	0.170	0.10	49.18	-	49.28	-	64.98	54.98	-15.70	-
2	0.318	0.10	45.10	-	45.20	-	59.76	49.76	-14.56	-
3	0.443	0.10	37.72	-	37.82	-	57.01	47.01	-19.19	-
4	1.138	0.10	30.88	-	30.98	-	56.00	46.00	-25.02	-
5	3.672	0.18	27.26	-	27.44	-	56.00	46.00	-28.56	-
6	9.625	0.59	24.20	-	24.79	-	60.00	50.00	-35.21	-

- NOTES: (1) "\*": Undetectable  
 (2) Q.P. and AV. are abbreviations of quasi-peak and average.  
 (3) "-": The Quasi-peak reading value also meets an average limit, thus measurement with the average detector is unnecessary.  
 (4) The emission levels of other frequencies were very low against the limit.  
 (5) Correction Factor = Insertion loss + Cable loss  
 (6) Margin value = Emission level - Limit value

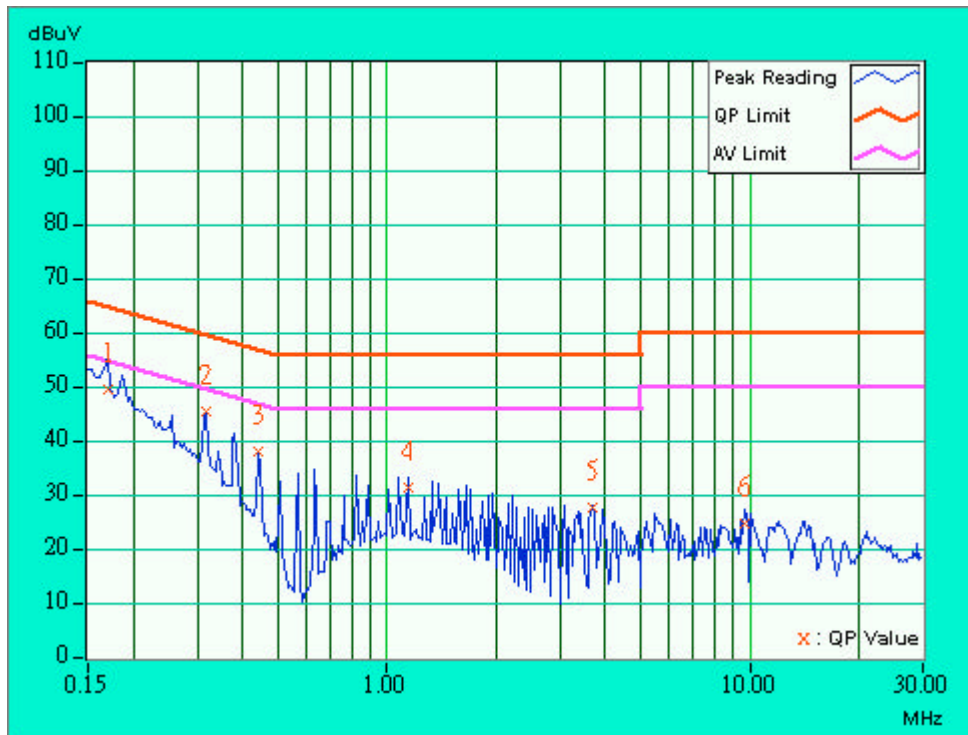



<b>EUT</b>	IEEE 802.11g miniPCI	<b>MODEL</b>	WN4401
<b>MODE</b>	Channel 1	<b>6dB BANDWIDTH</b>	9 kHz
<b>INPUT POWER (SYSTEM)</b>	120Vac, 60 Hz	<b>PHASE</b>	Neutral (N)
<b>ENVIRONMENTAL CONDITIONS</b>	20 deg. C, 60%RH, 979 hPa	<b>TESTED BY</b>	Mike Hsieh

No	Freq. [MHz]	Corr. Factor (dB)	Reading Value [dB (uV)]		Emission Level [dB (uV)]		Limit [dB (uV)]		Margin (dB)	
			Q.P.	AV.	Q.P.	AV.	Q.P.	AV.	Q.P.	AV.
1	0.170	0.10	48.56	-	48.66	-	64.98	54.98	-16.32	-
2	0.318	0.10	45.68	-	45.78	-	59.76	49.76	-13.98	-
3	0.443	0.10	41.73	-	41.83	-	57.01	47.01	-15.18	-
4	0.630	0.10	36.32	-	36.42	-	56.00	46.00	-19.58	-
5	1.709	0.10	28.06	-	28.16	-	56.00	46.00	-27.84	-
6	14.121	0.58	20.48	-	21.06	-	60.00	50.00	-38.94	-

- NOTES: (1) "-": Undetectable  
 (2) Q.P. and AV. are abbreviations of quasi-peak and average.  
 (3) "-": The Quasi-peak reading value also meets an average limit, thus measurement with the average detector is unnecessary.  
 (4) The emission levels of other frequencies were very low against the limit.  
 (5) Correction Factor = Insertion loss + Cable loss  
 (6) Margin value = Emission level - Limit value

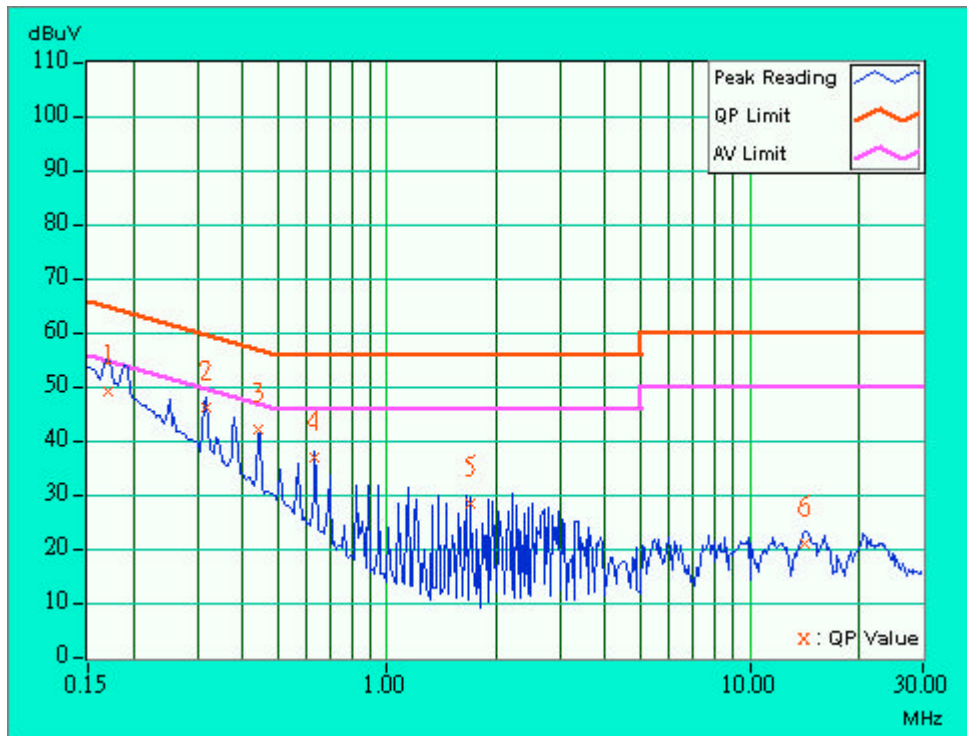



<b>EUT</b>	IEEE 802.11g miniPCI	<b>MODEL</b>	WN4401
<b>MODE</b>	Channel 6	<b>6dB BANDWIDTH</b>	9 kHz
<b>INPUT POWER (SYSTEM)</b>	120Vac, 60 Hz	<b>PHASE</b>	Line (L)
<b>ENVIRONMENTAL CONDITIONS</b>	20 deg. C, 60%RH, 979 hPa	<b>TESTED BY</b>	Mike Hsieh

No	Freq. [MHz]	Corr. Factor (dB)	Reading Value [dB (uV)]		Emission Level [dB (uV)]		Limit [dB (uV)]		Margin (dB)	
			Q.P.	AV.	Q.P.	AV.	Q.P.	AV.	Q.P.	AV.
1	0.170	0.10	49.08	-	49.18	-	64.98	54.98	-15.80	-
2	0.318	0.10	45.22	-	45.32	-	59.76	49.76	-14.44	-
3	0.443	0.10	38.34	-	38.44	-	57.01	47.01	-18.57	-
4	0.822	0.10	33.55	-	33.65	-	56.00	46.00	-22.35	-
5	2.216	0.11	28.79	-	28.90	-	56.00	46.00	-27.10	-
6	10.066	0.60	24.64	-	25.24	-	60.00	50.00	-34.76	-

- NOTES: (1) "-": Undetectable  
 (2) Q.P. and AV. are abbreviations of quasi-peak and average.  
 (3) "-": The Quasi-peak reading value also meets an average limit, thus measurement with the average detector is unnecessary.  
 (4) The emission levels of other frequencies were very low against the limit.  
 (5) Correction Factor = Insertion loss + Cable loss  
 (6) Margin value = Emission level - Limit value

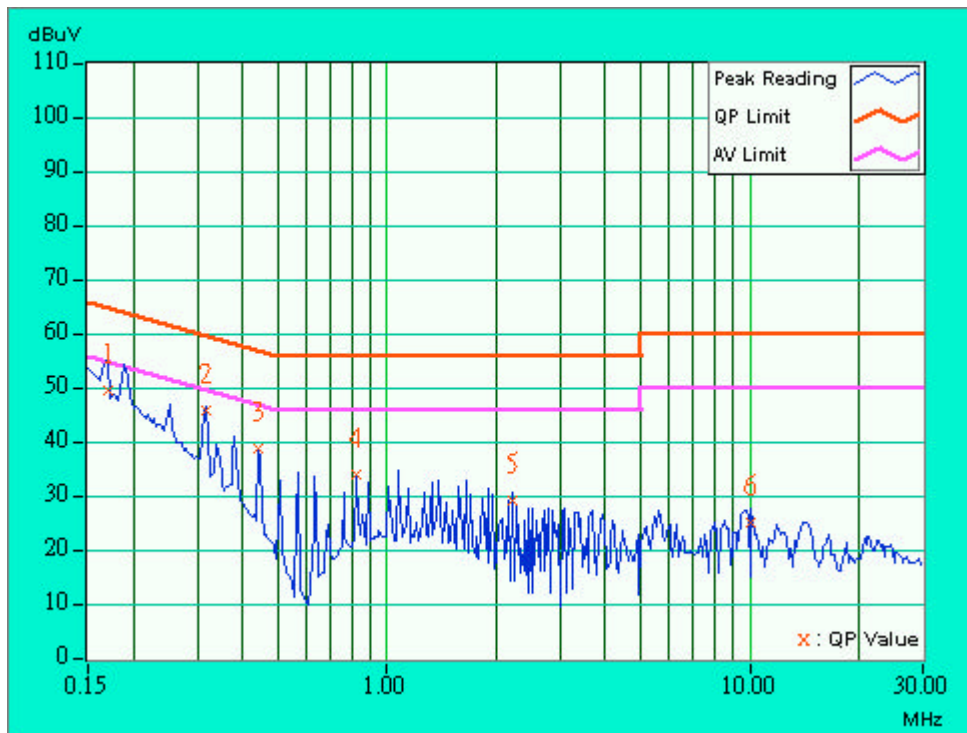



<b>EUT</b>	IEEE 802.11g miniPCI	<b>MODEL</b>	WN4401
<b>MODE</b>	Channel 6	<b>6dB BANDWIDTH</b>	9 kHz
<b>INPUT POWER (SYSTEM)</b>	120Vac, 60 Hz	<b>PHASE</b>	Neutral (N)
<b>ENVIRONMENTAL CONDITIONS</b>	20 deg. C, 60%RH, 979 hPa	<b>TESTED BY</b>	Mike Hsieh

No	Freq. [MHz]	Corr. Factor (dB)	Reading Value [dB (uV)]		Emission Level [dB (uV)]		Limit [dB (uV)]		Margin (dB)	
			Q.P.	AV.	Q.P.	AV.	Q.P.	AV.	Q.P.	AV.
1	0.170	0.10	48.60	-	48.70	-	64.98	54.98	-16.28	-
2	0.318	0.10	45.72	-	45.82	-	59.76	49.76	-13.94	-
3	0.443	0.10	41.69	-	41.79	-	57.01	47.01	-15.22	-
4	0.634	0.10	36.97	-	37.07	-	56.00	46.00	-18.93	-
5	1.646	0.10	29.19	-	29.29	-	56.00	46.00	-26.71	-
6	14.500	0.59	19.64	-	20.23	-	60.00	50.00	-39.77	-

- NOTES: (1) "-": Undetectable  
 (2) Q.P. and AV. are abbreviations of quasi-peak and average.  
 (3) "-": The Quasi-peak reading value also meets an average limit, thus measurement with the average detector is unnecessary.  
 (4) The emission levels of other frequencies were very low against the limit.  
 (5) Correction Factor = Insertion loss + Cable loss  
 (6) Margin value = Emission level - Limit value

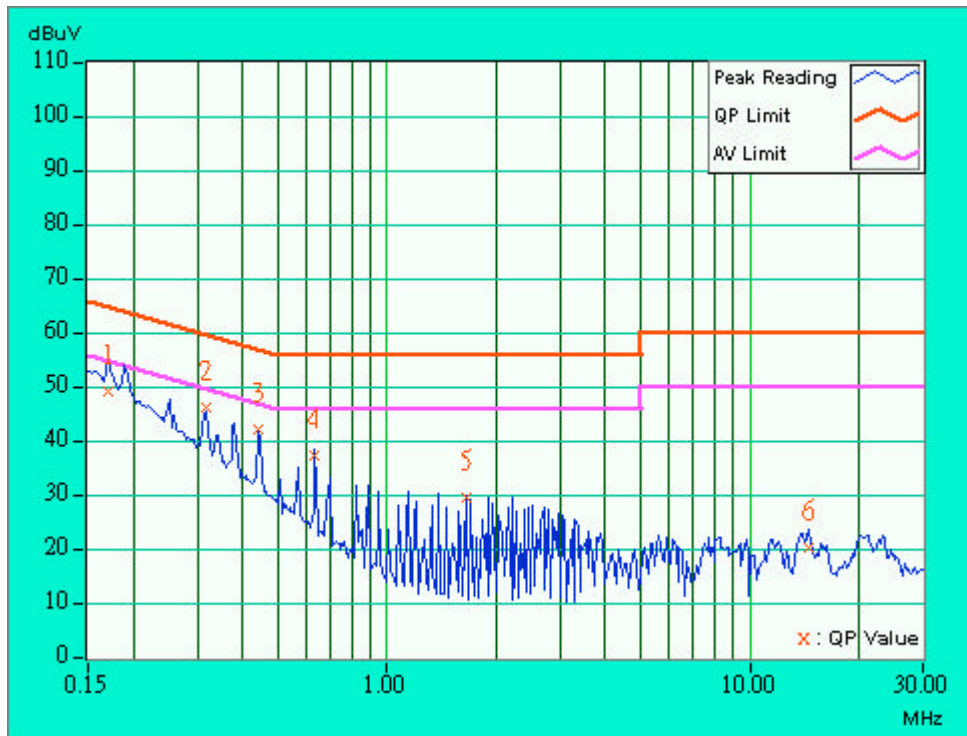





<b>EUT</b>	IEEE 802.11g miniPCI	<b>MODEL</b>	WN4401
<b>MODE</b>	Channel 11	<b>6dB BANDWIDTH</b>	9 kHz
<b>INPUT POWER (SYSTEM)</b>	120Vac, 60 Hz	<b>PHASE</b>	Line (L)
<b>ENVIRONMENTAL CONDITIONS</b>	20 deg. C, 60%RH, 979 hPa	<b>TESTED BY</b>	Mike Hsieh

No	Freq. [MHz]	Corr. Factor (dB)	Reading Value [dB (uV)]		Emission Level [dB (uV)]		Limit [dB (uV)]		Margin (dB)	
			Q.P.	AV.	Q.P.	AV.	Q.P.	AV.	Q.P.	AV.
1	0.170	0.10	49.11	-	49.21	-	64.98	54.98	-15.77	-
2	0.318	0.10	44.99	-	45.09	-	59.76	49.76	-14.67	-
3	0.443	0.10	38.25	-	38.35	-	57.01	47.01	-18.66	-
4	0.822	0.10	33.51	-	33.61	-	56.00	46.00	-22.39	-
5	1.646	0.10	31.59	-	31.69	-	56.00	46.00	-24.31	-
6	5.762	0.36	24.85	-	25.21	-	60.00	50.00	-34.79	-

- NOTES: (1) "-": Undetectable  
 (2) Q.P. and AV. are abbreviations of quasi-peak and average.  
 (3) "-": The Quasi-peak reading value also meets an average limit, thus measurement with the average detector is unnecessary.  
 (4) The emission levels of other frequencies were very low against the limit.  
 (5) Correction Factor = Insertion loss + Cable loss  
 (6) Margin value = Emission level - Limit value

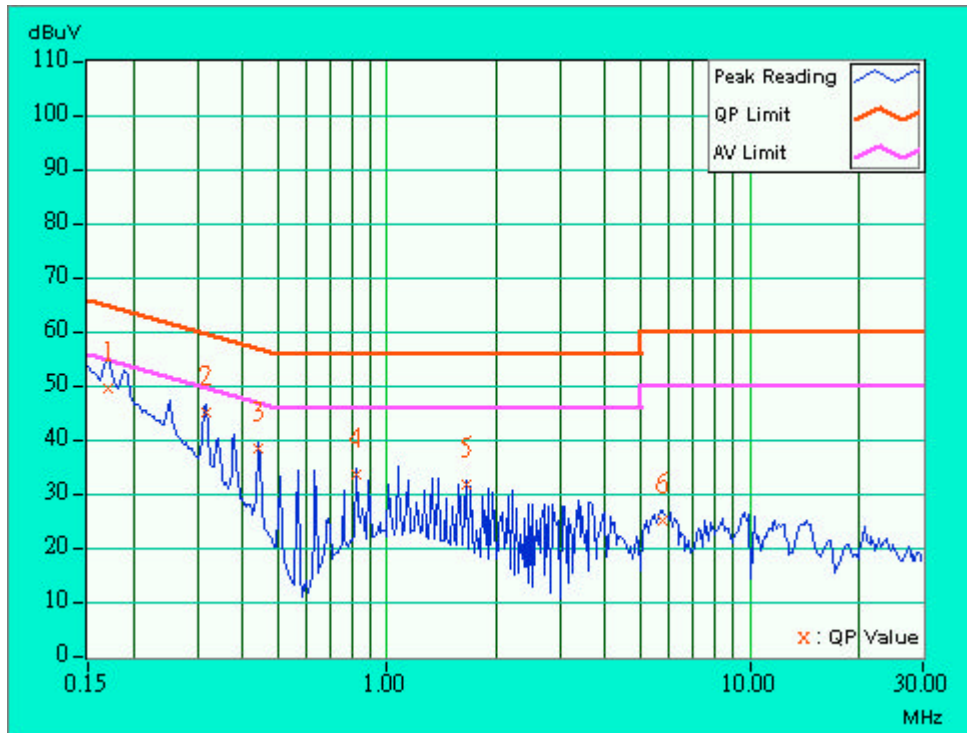



<b>EUT</b>	IEEE 802.11g miniPCI	<b>MODEL</b>	WN4401
<b>MODE</b>	Channel 11	<b>6dB BANDWIDTH</b>	9 kHz
<b>INPUT POWER (SYSTEM)</b>	120Vac, 60 Hz	<b>PHASE</b>	Neutral (N)
<b>ENVIRONMENTAL CONDITIONS</b>	20 deg. C, 60%RH, 979 hPa	<b>TESTED BY</b>	Mike Hsieh

No	Freq. [MHz]	Corr. Factor (dB)	Reading Value [dB (uV)]		Emission Level [dB (uV)]		Limit [dB (uV)]		Margin (dB)	
			Q.P.	AV.	Q.P.	AV.	Q.P.	AV.	Q.P.	AV.
1	0.170	0.10	48.60	-	48.70	-	64.98	54.98	-16.28	-
<b>2</b>	<b>0.318</b>	<b>0.10</b>	<b>45.78</b>	-	<b>45.88</b>	-	<b>59.76</b>	<b>49.76</b>	<b>-13.88</b>	-
3	0.443	0.10	41.89	-	41.99	-	57.01	47.01	-15.02	-
4	0.634	0.10	37.22	-	37.32	-	56.00	46.00	-18.68	-
5	2.216	0.11	28.79	-	28.90	-	56.00	46.00	-27.10	-
6	14.063	0.58	20.22	-	20.80	-	60.00	50.00	-39.20	-

- NOTES: (1) "x": Undetectable  
 (2) Q.P. and AV. are abbreviations of quasi-peak and average.  
 (3) "-": The Quasi-peak reading value also meets an average limit, thus measurement with the average detector is unnecessary.  
 (4) The emission levels of other frequencies were very low against the limit.  
 (5) Correction Factor = Insertion loss + Cable loss  
 (6) Margin value = Emission level - Limit value

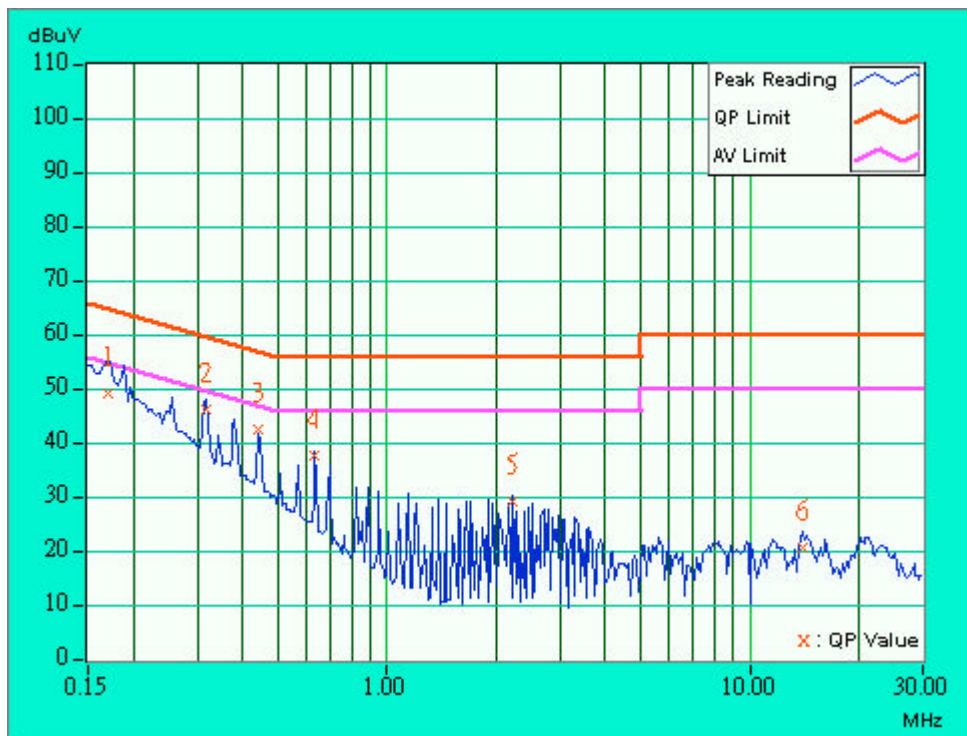



## 4.2 RADIATED EMISSION MEASUREMENT

### 4.2.1 LIMITS OF RADIATED EMISSION MEASUREMENT

Field strength limits are at the distance of 3 meters, emissions radiated outside of the specified bands, shall be according to the general radiated limits in 15.209 as following:

Frequencies (MHz)	Field Strength of Fundamental	
	uV/m	dBuV/m
30-88	100	40.0
88-216	150	43.5
216-960	200	46.0
Above 960	500	54.0

#### NOTE

1. The lower limit shall apply at the transition frequencies.
2. Emission level (dBuV/m) = 20 log Emission level (uV/m).
3. As shown in 15.35(b), for frequencies above 1000MHz, the field strength limits are based on average detector, however, the peak field strength of any emission shall not exceed the maximum permitted average limits, specified above by more than 20dB under any condition of modulation.



## 4.2.2 TEST INSTRUMENTS

DESCRIPTION & MANUFACTURER	MODEL NO.	SERIAL NO.	CALIBRATED UNTIL
HP Spectrum Analyzer	8594ER	3829U04676	Jul. 14, 2003
ADVANTEST Spectrum Analyzer	R3271A	85060311	May 21, 2003
CHASE RF Pre_Amplifier	CPA9232	1057	Apr. 24, 2003
HP Pre_Amplifier	8449B	3008A01281	June 27, 2003
ROHDE & SCHWARZ Test Receiver	ESVS 10	849231 /019	Nov. 03, 2003
CHASE Broadband Antenna	CBL6111c	2730	Jul 17, 2003
Schwarzbeck Horn_Antenna	BBHA9120-D1	D123	Jul. 31, 2003
SCHWARZBECK Tunable Dipole Antenna	UHAP	897	Mar. 07, 2005
SCHWARZBECK Tunable Dipole Antenna	VHAP	880	Mar. 07, 2005
RF Switches (ARNITSU)	CS-201	1565157	Jul. 29, 2003
RF CABLE (Chaintek) 1GHz-20GHz	Ak 9515-D	001	Aug, 20.2003
RF Cable(RICHTEC)	9913-30M	STCCAB-30M- 1GHz-021	Nov. 5, 2003
Software	AS60P8	NA	NA
CHANCE MOST Antenna Tower	AT-100	0203	NA
CHANCE MOST Turn Table	TT-100	0203	NA

Note: 1. The calibration interval of the above test instruments is 12 months (36 months for Tunable Dipole Antenna) and the calibrations are traceable to NML/ROC and NIST/USA.

2. \* = These equipment are used for the final measurement.
3. The horn antenna and HP preamplifier (model: 8449B) are used only for the measurement of emission frequency above 1GHz if tested.
4. The test was performed in ADT Open Site No. C.
5. The FCC Site Registration No. is 656396.
6. The VCCI Site Registration No. is R-1626.



#### 4.2.3 TEST PROCEDURES

- a. The EUT was placed on the top of a rotating table 0.8 meters above the ground at a 10 meter open area test site. The table was rotated 360 degrees to determine the position of the highest radiation.
- b. The EUT was set 3 meters away from the interference-receiving antenna, which was mounted on the top of a variable-height antenna tower.
- c. The antenna is a broadband antenna, and its height is varied from one meter to four meters above the ground to determine the maximum value of the field strength. Both horizontal and vertical polarizations of the antenna are set to make the measurement.
- d. For each suspected emission, the EUT was arranged to its worst case and then the antenna was tuned to heights from 1 meter to 4 meters and the rotatable table was turned from 0 degrees to 360 degrees to find the maximum reading.
- e. The test-receiver system was set to Peak Detect Function and Specified Bandwidth with Maximum Hold Mode.
- f. If the emission level of the EUT in peak mode was 10 dB lower than the limit specified, then testing could be stopped and the peak values of the EUT would be reported. Otherwise the emissions that did not have 10 dB margin would be re-tested one by one using peak, quasi-peak or average method as specified and then reported in a data sheet.

**NOTE:**

1. The resolution bandwidth and video bandwidth of test receiver/spectrum analyzer is 120kHz for Peak detection (PK) and Quasi-peak detection (QP) at frequency below 1GHz.
2. The resolution bandwidth and video bandwidth of test receiver/spectrum analyzer is 1 MHz for Peak detection at frequency above 1GHz.
3. The resolution bandwidth of test receiver/spectrum analyzer is 1 MHz and the video bandwidth is 300 Hz for Average detection (AV) at frequency above 1GHz.

#### 4.2.4 TEST SETUP

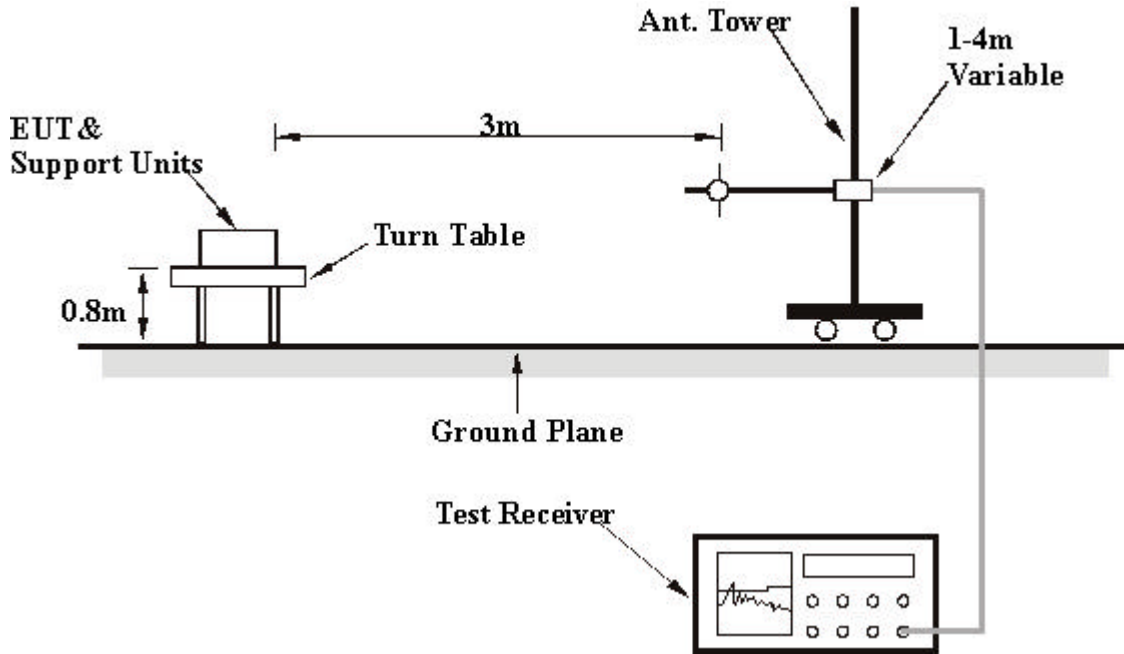

For the actual test configuration, please refer to the related item – Photographs of the Test Configuration.

#### 4.2.5 EUT OPERATING CONDITIONS

Same as 4.1.5.



## 4.2.6 TEST RESULTS (A)

<b>EUT</b>	IEEE 802.11g miniPCI	<b>MODEL</b>	WN4401
<b>MODE</b>	Channel 11	<b>FREQUENCY RANGE</b>	30-1000 MHz
<b>INPUT POWER (SYSTEM)</b>	120Vac, 60 Hz	<b>DETECTOR FUNCTION</b>	Quasi-Peak
<b>ENVIRONMENTAL CONDITIONS</b>	20 deg. C, 84 % RH, 979 hPa	<b>TESTED BY</b>	Eric Lee

**ANTENNA POLARITY & TEST DISTANCE: HORIZONTAL AT 3 M**

No.	Freq. (MHz)	Emission Level (dBuV/m)	Limit (dBuV/m)	Margin (dB)	Antenna Height (m)	Table Angle (Degree)	Raw Value (dBuV)	Correction Factor (dB/m)
1	264.00	31.3 QP	46.00	-14.70	1.42 H	26	17.20	14.10
2	320.00	38.2 QP	46.00	-7.80	1.03 H	144	23.70	14.50
3	330.00	25.2 QP	46.00	-20.80	1.14 H	196	10.30	14.90
4	396.01	31.1 QP	46.00	-14.90	1.24 H	183	14.30	16.90
5	440.00	32.1 QP	46.00	-13.90	1.06 H	14	14.10	18.00
6	484.00	27.5 QP	46.00	-18.50	1.00 H	253	8.50	19.00
7	528.02	32.5 QP	46.00	-13.50	1.78 H	121	12.80	19.70
8	572.00	24.0 QP	46.00	-22.00	1.27 H	98	2.60	21.40
9	659.98	29.7 QP	46.00	-16.30	1.05 H	120	7.50	22.20
10	924.00	27.6 QP	46.00	-18.40	1.00 H	126	1.60	26.00

**ANTENNA POLARITY & TEST DISTANCE: VERTICAL AT 3 M**

No.	Freq. (MHz)	Emission Level (dBuV/m)	Limit (dBuV/m)	Margin (dB)	Antenna Height (m)	Table Angle (Degree)	Raw Value (dBuV)	Correction Factor (dB/m)
1	66.88	37.2 QP	40.00	-2.80	1.23 V	4	31.60	5.60
2	125.00	24.7 QP	43.50	-18.80	1.00 V	66	12.50	12.10
3	264.00	34.1 QP	46.00	-11.90	1.49 V	275	20.10	14.10
4	308.00	28.8 QP	46.00	-17.20	1.47 V	46	14.50	14.30
5	320.00	40.1 QP	46.00	-5.90	1.27 V	28	25.50	14.50
6	330.00	30.2 QP	46.00	-15.80	1.21 V	32	15.30	14.90
7	352.00	28.8 QP	46.00	-17.20	1.25 V	120	13.20	15.60
8	396.00	32.5 QP	46.00	-13.50	1.38 V	97	15.60	16.90
9	440.00	40.8 QP	46.00	-5.20	1.34 V	127	22.80	18.00
10	484.00	28.8 QP	46.00	-17.20	1.05 V	152	9.80	19.00
11	528.00	37.9 QP	46.00	-8.10	1.00 V	16	18.10	19.70
12	572.00	29.1 QP	46.00	-16.90	1.00 V	76	7.70	21.40
13	660.00	33.1 QP	46.00	-12.90	1.01 V	143	10.90	22.20
14	924.00	31.0 QP	46.00	-15.00	1.00 V	4	5.00	26.00

- REMARKS:**
1. Emission level(dBuV/m)=Raw Value(dBuV) + Correction Factor(dB)
  2. Correction Factor(dB/m) = Antenna Factor (dB/m) + Cable Factor (dB)
  3. The other emission levels were very low against the limit.
  4. Margin value = Emission level – Limit value.
  5. The limit value is defined as per 15.247



## 4.2.7 TEST RESULTS (A) - DSSS

<b>EUT</b>	IEEE 802.11g miniPCI	<b>MODEL</b>	WN4401
<b>MODE</b>	Channel 1	<b>FREQUENCY RANGE</b>	Above 1000 MHz
<b>INPUT POWER (SYSTEM)</b>	120Vac, 60 Hz	<b>DETECTOR FUNCTION</b>	Peak(PK) Average(AV)
<b>ENVIRONMENTAL CONDITIONS</b>	19 deg. C, 76%RH, 979 hPa	<b>TESTED BY</b>	Eric Lee

**ANTENNA POLARITY & TEST DISTANCE: HORIZONTAL AT 3 M**

No.	Freq. (MHz)	Emission Level (dBuV/m)	Limit (dBuV/m)	Margin (dB)	Antenna Height (m)	Table Angle (Degree)	Raw Value (dBuV)	Correction Factor (dB/m)
1	2376.00	54.8 PK	74.00	-19.20	1.78 H	238	25.10	29.70
1	2376.00	37.3 AV	54.00	-16.70	1.78 H	238	7.60	29.70
2	*2412.00	104.0 PK			1.01 H	75	74.10	29.90
2	*2412.00	96.9 AV			1.01 H	75	67.00	29.90
3	2496.00	40.5 PK	74.00	-33.50	1.46 H	29	10.30	30.20
4	4824.00	42.7 PK	74.00	-31.30	1.82 H	112	6.40	36.20
5	7236.00	50.8 PK	74.00	-23.20	1.69 H	157	9.20	41.70
6	9648.00	48.2 PK	84.00	-35.80	1.50 H	73	3.30	44.90

**ANTENNA POLARITY & TEST DISTANCE: VERTICAL AT 3 M**

No.	Freq. (MHz)	Emission Level (dBuV/m)	Limit (dBuV/m)	Margin (dB)	Antenna Height (m)	Table Angle (Degree)	Raw Value (dBuV)	Correction Factor (dB/m)
1	2376.00	62.9 PK	74.00	-11.10	1.09 V	17	33.20	29.70
1	2376.00	44.8 AV	54.00	-9.20	1.09 V	17	15.10	29.70
2	*2412.00	109.7 PK			1.24 V	117	79.80	29.90
2	*2412.00	102.0 AV			1.24 V	117	72.10	29.90
3	2496.00	45.3 PK	74.00	-28.70	1.69 V	33	15.10	30.20
4	4824.00	51.1 PK	74.00	-22.90	1.00 V	94	14.80	36.20
4	4824.00	38.0 AV	54.00	-16.00	1.00 V	94	1.80	30.20
5	7236.00	54.7 PK	74.00	-19.30	1.26 V	35	13.00	41.70
5	7236.00	47.6 AV	54.00	-6.40	1.26 V	35	5.90	36.20
6	9648.00	51.5 PK	89.70	-38.20	1.29 V	128	6.60	44.90
6	9648.00	48.6 AV	82.00	-33.40	1.29 V	128	3.70	41.70

- REMARKS:**
1. Emission level(dBuV/m)=Raw Value(dBuV) + Correction Factor(dB)
  2. Correction Factor(dB/m) = Antenna Factor (dB/m) + Cable Factor (dB)
  3. The other emission levels were very low against the limit.
  4. Margin value = Emission level – Limit value.
  5. The limit value is defined as per 15.247
  6. “ \* ” : Fundamental frequency





<b>EUT</b>	IEEE 802.11g miniPCI	<b>MODEL</b>	WN4401
<b>MODE</b>	Channel 6	<b>FREQUENCY RANGE</b>	Above 1000 MHz
<b>INPUT POWER (SYSTEM)</b>	120Vac, 60 Hz	<b>DETECTOR FUNCTION</b>	Peak(PK) Average (AV)
<b>ENVIRONMENTAL CONDITIONS</b>	19 deg. C, 76%RH, 979 hPa	<b>TESTED BY</b>	Eric Lee

#### ANTENNA POLARITY & TEST DISTANCE: HORIZONTAL AT 3 M

No.	Freq. (MHz)	Emission Level (dBuV/m)	Limit (dBuV/m)	Margin (dB)	Antenna Height (m)	Table Angle (Degree)	Raw Value (dBuV)	Correction Factor (dB/m)
1	2376.00	38.8 PK	74.00	-35.20	1.45 H	111	9.10	29.70
2	*2437.00	105.7 PK			1.52 H	45	75.70	30.00
2	*2437.00	99.0 AV			1.52 H	45	69.00	29.70
3	2496.00	50.7 PK	74.00	-23.30	1.53 H	20	20.50	30.20
4	4874.00	51.7 PK	74.00	-22.30	1.70 H	23	15.20	36.50
4	4874.00	43.9 AV	54.00	-10.10	1.70 H	23	7.50	30.00
5	7311.00	48.9 PK	74.00	-25.10	1.49 H	170	7.20	41.80
6	9748.00	50.0 PK	85.70	-35.70	1.73 H	99	5.30	44.60

#### ANTENNA POLARITY & TEST DISTANCE: VERTICAL AT 3 M

No.	Freq. (MHz)	Emission Level (dBuV/m)	Limit (dBuV/m)	Margin (dB)	Antenna Height (m)	Table Angle (Degree)	Raw Value (dBuV)	Correction Factor (dB/m)
1	2376.00	43.5 PK	74.00	-30.50	1.30 V	11	13.80	29.70
2	*2437.00	112.6 PK			1.27 V	12	91.40	30.00
2	*2437.00	105.6 AV			1.27 V	12	75.60	29.70
3	2496.00	51.2 PK	74.00	-22.80	1.25 V	1	21.00	30.20
3	2496.00	39.5 AV	54.00	-14.50	1.25 V	1	9.30	30.00
4	4874.00	57.4 PK	74.00	-16.60	1.03 V	29	20.90	36.50
4	4874.00	49.0 AV	54.00	-5.00	1.03 V	29	12.60	30.20
5	7311.00	50.7 PK	74.00	-23.30	1.30 V	98	9.00	41.80
6	9748.00	55.3 PK	92.60	-37.30	1.20 V	73	10.70	44.60
6	9748.00	52.0 AV	85.60	-33.60	1.20 V	73	7.40	36.50

- REMARKS:**
1. Emission level(dBuV/m)=Raw Value(dBuV) + Correction Factor(dB)
  2. Correction Factor(dB/m) = Antenna Factor (dB/m) + Cable Factor (dB)
  3. The other emission levels were very low against the limit.
  4. Margin value = Emission level – Limit value.
  5. The limit value is defined as per 15.247
  6. " \* " : Fundamental frequency



<b>EUT</b>	IEEE 802.11g miniPCI	<b>MODEL</b>	WN4401
<b>MODE</b>	Channel 11	<b>FREQUENCY RANGE</b>	Above 1000 MHz
<b>INPUT POWER (SYSTEM)</b>	120Vac, 60 Hz	<b>DETECTOR FUNCTION</b>	Peak(PK) Average (AV)
<b>ENVIRONMENTAL CONDITIONS</b>	19 deg. C, 76%RH, 979 hPa	<b>TESTED BY</b>	Eric Lee

#### ANTENNA POLARITY & TEST DISTANCE: HORIZONTAL AT 3 M

No.	Freq. (MHz)	Emission Level (dBuV/m)	Limit (dBuV/m)	Margin (dB)	Antenna Height (m)	Table Angle (Degree)	Raw Value (dBuV)	Correction Factor (dB/m)
1	2380.00	38.7 PK	74.00	-35.30	1.34 H	40	9.00	29.70
2	*2462.00	103.7 PK			1.51 H	51	73.60	30.10
2	*2462.00	96.8 AV			1.51 H	51	66.70	29.70
3	2490.00	54.7 PK	74.00	-19.30	1.62 H	45	24.50	30.20
3	2490.00	39.2 AV	54.00	-14.80	1.62 H	45	9.00	30.10
4	4924.00	49.2 PK	74.00	-24.80	1.82 H	81	12.50	36.70
5	7386.00	47.8 PK	74.00	-26.20	1.31 H	44	6.00	41.80
6	9848.00	48.9 PK	83.70	-34.80	1.39 H	2	4.50	44.40

#### ANTENNA POLARITY & TEST DISTANCE: VERTICAL AT 3 M

No.	Freq. (MHz)	Emission Level (dBuV/m)	Limit (dBuV/m)	Margin (dB)	Antenna Height (m)	Table Angle (Degree)	Raw Value (dBuV)	Correction Factor (dB/m)
1	2386.00	47.5 PK	74.00	-26.50	1.24 V	12	17.80	29.80
2	*2462.00	110.1 PK			1.06 V	11	80.00	30.10
2	*2462.00	103.0 AV			1.06 V	11	72.90	29.80
3	2490.00	63.0 PK	74.00	-11.00	1.24 V	12	32.90	30.20
3	2490.00	36.9 AV	54.00	-17.10	1.24 V	12	6.80	30.10
4	4924.00	57.0 PK	74.00	-17.00	1.06 V	95	20.30	36.70
4	4924.00	47.1 AV	54.00	-6.90	1.06 V	95	10.40	30.20
5	7386.00	49.3 PK	74.00	-24.70	1.02 V	1	7.50	41.80
6	9848.00	53.1 PK	90.10	-37.00	1.18 V	66	8.80	44.40
6	9848.00	49.9 AV	83.00	-33.10	1.18 V	66	5.50	36.70

- REMARKS:**
1. Emission level(dBuV/m)=Raw Value(dBuV) + Correction Factor(dB)
  2. Correction Factor(dB/m) = Antenna Factor (dB/m) + Cable Factor (dB)
  3. The other emission levels were very low against the limit.
  4. Margin value = Emission level – Limit value.
  5. The limit value is defined as per 15.247
  6. “ \* “ : Fundamental frequency