



# FCC TEST REPORT

**REPORT NO.:** RF920725H01F

**MODEL NO.:** RBT3K-AG, RBT3K-AG-G

**RECEIVED:** Jul. 25, 2003

**TESTED:** Jul. 27 to Oct. 09, 2003

**APPLICANT:** Accton Technology Corporation

**ADDRESS:** No.1, Creation Rd. III, Science-based Industrial Park, Hsinchu, Taiwan, R.O.C.

**ISSUED BY:** Advance Data Technology Corporation

**LAB LOCATION:** No. 81-1, Lu Liao Keng, 9 Ling, Wu Lung Tsuen, Chiung Lin Hsiang, Hsin Chu Hsien, Taiwan, R.O.C.

This test report consists of 178 pages in total. It may be duplicated completely for legal use with the approval of the applicant. It should not be reproduced except in full, without the written approval of our laboratory. The client should not use it to claim product endorsement by CNLA or any government agencies. The test results in the report only apply to the tested sample.



0536

ILAC MRA



## Table of Contents

|       |   |    |
|-------|---|----|
| 1.    | CERTIFICATION .....                                   | 5  |
| 2.    | SUMMARY OF TEST RESULTS .....                         | 6  |
| 3.    | GENERAL INFORMATION .....                             | 9  |
| 3.1   | GENERAL DESCRIPTION OF EUT .....                      | 9  |
| 3.2   | DESCRIPTION OF TEST MODES .....                       | 11 |
| 3.3   | GENERAL DESCRIPTION OF APPLIED STANDARDS .....        | 12 |
| 3.4   | DESCRIPTION OF SUPPORT UNITS.....                     | 13 |
| 4.    | TEST TYPES AND RESULTS (FOR PART 802.11B).....        | 16 |
| 4.1   | CONDUCTED EMISSION MEASUREMENT .....                  | 16 |
| 4.1.1 | LIMITS OF CONDUCTED EMISSION MEASUREMENT.....         | 16 |
| 4.1.2 | TEST INSTRUMENTS.....                                 | 16 |
| 4.1.3 | TEST PROCEDURES .....                                 | 17 |
| 4.1.4 | DEVIATION FROM TEST STANDARD .....                    | 17 |
| 4.1.5 | TEST SETUP .....                                      | 18 |
| 4.1.6 | EUT OPERATING CONDITIONS .....                        | 18 |
| 4.1.7 | TEST RESULTS .....                                    | 19 |
| 4.1.8 | TEST RESULTS .....                                    | 21 |
| 4.2   | RADIATED EMISSION MEASUREMENT .....                   | 23 |
| 4.2.1 | LIMITS OF RADIATED EMISSION MEASUREMENT.....          | 23 |
| 4.2.2 | TEST INSTRUMENTS.....                                 | 24 |
| 4.2.3 | TEST PROCEDURES .....                                 | 25 |
| 4.2.4 | DEVIATION FROM TEST STANDARD .....                    | 25 |
| 4.2.5 | TEST SETUP .....                                      | 26 |
| 4.2.6 | EUT OPERATING CONDITIONS .....                        | 26 |
| 4.2.7 | TEST RESULTS .....                                    | 27 |
| 4.3   | 6DB BANDWIDTH MEASUREMENT .....                       | 35 |
| 4.3.1 | LIMITS OF 6DB BANDWIDTH MEASUREMENT .....             | 35 |
| 4.3.2 | TEST INSTRUMENTS.....                                 | 35 |
| 4.3.3 | TEST PROCEDURE.....                                   | 36 |
| 4.3.4 | DEVIATION FROM TEST STANDARD .....                    | 36 |
| 4.3.5 | TEST SETUP .....                                      | 36 |
| 4.3.6 | EUT OPERATING CONDITIONS .....                        | 36 |
| 4.3.7 | TEST RESULTS (A) .....                                | 37 |
| 4.3.8 | TEST RESULTS (B) .....                                | 41 |
| 4.4   | MAXIMUM PEAK OUTPUT POWER.....                        | 45 |
| 4.4.1 | LIMITS OF MAXIMUM PEAK OUTPUT POWER MEASUREMENT ..... | 45 |
| 4.4.2 | INSTRUMENTS.....                                      | 45 |
| 4.4.3 | TEST PROCEDURES .....                                 | 46 |
| 4.4.4 | TEST SETUP .....                                      | 46 |
| 4.4.5 | EUT OPERATING CONDITIONS .....                        | 46 |
| 4.4.6 | TEST RESULTS (A) .....                                | 47 |
| 4.4.7 | TEST RESULTS (B) .....                                | 47 |
| 4.5   | POWER SPECTRAL DENSITY MEASUREMENT.....               | 48 |
| 4.5.1 | LIMITS OF POWER SPECTRAL DENSITY MEASUREMENT .....    | 48 |
| 4.5.2 | TEST INSTRUMENTS.....                                 | 48 |
| 4.5.3 | TEST PROCEDURE.....                                   | 49 |
| 4.5.4 | DEVIATION FROM TEST STANDARD .....                    | 49 |
| 4.5.5 | TEST SETUP .....                                      | 49 |
| 4.5.6 | EUT OPERATING CONDITION.....                          | 49 |
| 4.5.7 | TEST RESULTS(A) .....                                 | 50 |
| 4.5.8 | TEST RESULTS(B) .....                                 | 54 |



|       |  |     |
|-------|--|-----|
| 4.6   | BAND EDGES MEASUREMENT.....                                  | 58  |
| 4.6.1 | LIMITS OF BAND EDGES MEASUREMENT .....                       | 58  |
| 4.6.2 | TEST INSTRUMENTS.....  | 58  |
| 4.6.3 | TEST PROCEDURE.....  | 58  |
| 4.6.4 | DEVIATION FROM TEST STANDARD .....                           | 58  |
| 4.6.5 | EUT OPERATING CONDITION.....                                 | 59  |
| 4.6.6 | TEST RESULTS (A) .....                                       | 59  |
| 4.6.7 | TEST RESULTS (B) .....                                       | 62  |
| 4.7   | ANTENNA REQUIREMENT .....                                    | 65  |
| 4.7.1 | STANDARD APPLICABLE.....                                     | 65  |
| 4.7.2 | ANTENNA CONNECTED CONSTRUCTION.....                          | 65  |
| 5.    | TEST TYPES AND RESULTS (FOR PART 802.11A).....               | 66  |
| 5.1   | CONDUCTED EMISSION MEASUREMENT .....                         | 66  |
| 5.1.1 | LIMITS OF CONDUCTED EMISSION MEASUREMENT .....               | 66  |
| 5.1.2 | TEST INSTRUMENTS.....  | 66  |
| 5.1.3 | TEST PROCEDURES .....  | 67  |
| 5.1.4 | DEVIATION FROM TEST STANDARD .....                           | 67  |
| 5.1.5 | TEST SETUP .....   | 68  |
| 5.1.6 | EUT OPERATING CONDITIONS .....                               | 68  |
| 5.1.7 | TEST RESULTS .....   | 69  |
| 5.2   | RADIATED EMISSION MEASUREMENT .....                          | 77  |
| 5.2.1 | LIMITS OF RADIATED EMISSION MEASUREMENT .....                | 77  |
| 5.2.2 | LIMITS OF UNWANTED EMISSION OUT OF THE RESTRICTED BANDS..... | 78  |
| 5.2.3 | TEST INSTRUMENTS.....  | 79  |
| 5.2.4 | TEST PROCEDURES .....  | 80  |
| 5.2.5 | DEVIATION FROM TEST STANDARD .....                           | 80  |
| 5.2.6 | TEST SETUP .....   | 81  |
| 5.2.7 | EUT OPERATING CONDITIONS .....                               | 81  |
| 5.2.8 | TEST RESULTS .....   | 82  |
| 5.2.9 | TEST RESULTS .....   | 84  |
|       | FOR FREQUENCY 5.15~5.35GHZ .....                             | 96  |
| 5.3   | PEAK TRANSMIT POWER MEASUREMENT .....                        | 96  |
| 5.3.1 | LIMITS OF PEAK TRANSMIT POWER MEASUREMENT .....              | 96  |
| 5.3.2 | TEST INSTRUMENTS.....  | 96  |
| 5.3.3 | TEST PROCEDURE.....  | 97  |
| 5.3.4 | TEST SETUP .....   | 97  |
| 5.3.5 | EUT OPERATING CONDITIONS .....                               | 97  |
| 5.3.6 | TEST RESULTS .....   | 98  |
| 5.4   | PEAK POWER EXCURSION MEASUREMENT .....                       | 114 |
| 5.4.1 | LIMITS OF PEAK POWER EXCURSION MEASUREMENT .....             | 114 |
| 5.4.2 | TEST INSTRUMENTS.....  | 114 |
| 5.4.3 | TEST PROCEDURE.....  | 115 |
| 5.4.4 | DEVIATION FROM TEST STANDARD .....                           | 115 |
| 5.4.5 | TEST SETUP .....   | 115 |
| 5.4.6 | EUT OPERATING CONDITIONS .....                               | 115 |
| 5.4.7 | TEST RESULTS .....   | 116 |
| 5.5   | PEAK POWER SPECTRAL DENSITY MEASUREMENT .....                | 125 |
| 5.5.1 | LIMITS OF PEAK POWER SPECTRAL DENSITY MEASUREMENT .....      | 125 |
| 5.5.2 | TEST INSTRUMENTS.....  | 125 |
| 5.5.3 | TEST PROCEDURES .....  | 126 |
| 5.5.4 | DEVIATION FROM TEST STANDARD .....                           | 126 |
| 5.5.5 | TEST SETUP .....   | 126 |
| 5.5.6 | EUT OPERATING CONDITIONS .....                               | 126 |
| 5.5.7 | TEST RESULTS .....   | 127 |



|        |  |     |
|--------|--|-----|
| 5.6    | FREQUENCY STABILITY.....                           | 136 |
| 5.6.1  | LIMITS OF FREQUENCY STABILITY MEASUREMENT .....    | 136 |
| 5.6.2  | TEST INSTRUMENTS.....                              | 136 |
| 5.6.3  | TEST PROCEDURE.....                                | 136 |
| 5.6.4  | DEVIATION FROM TEST STANDARD .....                 | 136 |
| 5.6.5  | TEST SETUP .....                                   | 137 |
| 5.6.6  | EUT OPERATING CONDITION.....                       | 137 |
| 5.6.7  | TEST RESULTS.....                                  | 138 |
| 5.7    | BAND EDGES MEASUREMENT.....                        | 139 |
| 5.7.1  | TEST INSTRUMENTS.....                              | 139 |
| 5.7.2  | TEST PROCEDURE.....                                | 139 |
| 5.7.3  | EUT OPERATING CONDITION.....                       | 139 |
| 5.7.4  | TEST RESULTS .....                                 | 140 |
| 5.8    | 6DB BANDWIDTH MEASUREMENT .....                    | 145 |
| 5.8.1  | LIMITS OF 6DB BANDWIDTH MEASUREMENT .....          | 145 |
| 5.8.2  | TEST INSTRUMENTS.....                              | 145 |
| 5.8.3  | TEST PROCEDURE.....                                | 146 |
| 5.8.4  | DEVIATION FROM TEST STANDARD .....                 | 146 |
| 5.8.5  | TEST SETUP .....                                   | 146 |
| 5.8.6  | EUT OPERATING CONDITIONS .....                     | 146 |
| 5.8.7  | TEST RESULTS .....                                 | 147 |
| 5.9    | MAXIMUM PEAK OUTPUT POWER.....                     | 154 |
| 5.9.1  | LIMITS OF PEAK TRANSMIT POWER MEASUREMENT .....    | 154 |
| 5.9.2  | INSTRUMENTS.....                                   | 154 |
| 5.9.3  | TEST PROCEDURES .....                              | 155 |
| 5.9.4  | TEST SETUP .....                                   | 155 |
| 5.9.5  | EUT OPERATING CONDITIONS .....                     | 155 |
| 5.9.6  | TEST RESULTS .....                                 | 156 |
| 5.9.7  | LIMITS OF POWER SPECTRAL DENSITY MEASUREMENT ..... | 157 |
| 5.9.8  | TEST INSTRUMENTS.....                              | 157 |
| 5.9.9  | TEST PROCEDURE.....                                | 158 |
| 5.9.10 | DEVIATION FROM TEST STANDARD .....                 | 158 |
| 5.9.11 | TEST SETUP .....                                   | 158 |
| 5.9.12 | EUT OPERATING CONDITION.....                       | 158 |
| 5.9.13 | TEST RESULTS .....                                 | 159 |
| 5.10   | BAND EDGES MEASUREMENT.....                        | 166 |
| 5.10.1 | LIMITS OF BAND EDGES MEASUREMENT .....             | 166 |
| 5.10.2 | TEST INSTRUMENTS.....                              | 166 |
| 5.10.3 | TEST PROCEDURE.....                                | 166 |
| 5.10.4 | DEVIATION FROM TEST STANDARD .....                 | 166 |
| 5.10.5 | EUT OPERATING CONDITION.....                       | 167 |
| 5.10.6 | TEST RESULTS .....                                 | 167 |
| 5.11   | ANTENNA REQUIREMENT .....                          | 172 |
| 5.11.1 | STANDARD APPLICABLE.....                           | 172 |
| 5.11.2 | ANTENNA CONNECTED CONSTRUCTION.....                | 172 |
| 6.     | PHOTOGRAPHS OF THE TEST CONFIGURATION.....         | 173 |
| 7.     | INFORMATION ON THE TESTING LABORATORIES .....      | 177 |



# 1. CERTIFICATION

Reference No.: 921211H02

**PRODUCT :** Wireless Dual Band Enterprise Access Point  
**BRAND NAME :** Enterasys  
**MODEL NO. :** RBT3K-AG, RBT3K-AG-G  
**APPLICANT :** Accton Technology Corporation  
**STANDARDS :** 47 CFR Part 15, Subpart C (Section 15.247),  
Subpart E (Section 15.407), ANSI C63.4-1992

We, **Advance Data Technology Corporation**, hereby certify that one sample of the designation has been tested in our facility from Jul. 27 to Oct. 09, 2003. The test record data evaluation and Equipment under Test (EUT) configurations represented herein are true and accurate accounts of the measurements of the sample's EMC characteristics under the conditions herein specified.

**PREPARED BY:** Midoli Peng, **DATE:** Feb. 09, 2004  
( Midoli Peng )

**APPROVED BY:** Eric Lin, **DATE:** Feb. 09, 2004  
( Eric Lin, Manager )



## 2. SUMMARY OF TEST RESULTS

The EUT has been tested according to the following specifications:

| <b>APPLIED STANDARD: 47 CFR Part 15, Subpart C</b> |  |               |  |
|--|--|---------------|--|
| <b>Standard Section</b>                            | <b>Test Type and Limit</b>   | <b>Result</b> | <b>REMARK</b>  |
| 15.207   | AC Power Conducted Emission  | PASS          | Meet the requirement of limit<br>Minimum passing margin is -10.58dBuV at 1.338MHz  |
| 15.247(a)(2)                                       | Spectrum Bandwidth of a Direct Sequence Spread Spectrum System<br>Limit: min. 500kHz   | PASS          | Meet the requirement of limit  |
| 15.247(b)  | Maximum Peak Output Power<br>Limit: max. 30dBm   | PASS          | Meet the requirement of limit  |
| 15.247(c)  | Radiated Emissions<br>Limit: Table 15.209  | PASS          | Meet the requirement of limit<br>Minimum passing margin is -0.9dBuV at 2390.00 MHz |
| 15.247(d)  | Power Spectral Density<br>Limit: max. 8dBm   | PASS          | Meet the requirement of limit  |
| 15.247(c)  | Band Edge Measurement<br>Limit: 20dB less than the peak value of fundamental frequency | PASS          | Meet the requirement of limit  |



for freq. 5.15~5.35GHz :

| <b>APPLIED STANDARD: 47 CFR Part 15, Subpart E</b> |  |               |   |
|--|--|---------------|---|
| <b>Standard Section</b>                            | <b>Test Type</b>   | <b>Result</b> | <b>REMARK</b>   |
| 15.407(b)(5)                                       | AC Power Conducted Emission                                    | PASS          | Meet the requirement of limit<br>Minimum passing margin is -10.78dBuV at 1.338MHz |
| 15.407(b)(1/2/5)                                   | Electric Field Strength Spurious Emissions, 30 MHz – 40000 MHz | PASS          | Meet the requirement of limit<br>Minimum passing margin is -1.0dBuV at 5408.00MHz |
| 15.407(a)(1/2)                                     | Peak Transmit Power  | PASS          | Meet the requirement of limit   |
| 15.407(a)(6)                                       | Peak Power Excursion   | PASS          | Meet the requirement of limit   |
| 15.407(a)(1/2/3)                                   | Peak Power Spectral Density                                    | PASS          | Meet the requirement of limit   |
| 15.407(g)  | Frequency Stability  | PASS          | Meet the requirement of limit   |



for freq. 5.725~5.850GHz :

| <b>APPLIED STANDARD: 47 CFR Part 15, Subpart C</b> |  |               |   |
|--|--|---------------|---|
| <b>Standard Section</b>                            | <b>Test Type and Limit</b>   | <b>Result</b> | <b>REMARK</b>   |
| 15.207   | AC Power Conducted Emission  | PASS          | Meet the requirement of limit<br>Minimum passing margin is -10.78dBuV at 1.338MHz |
| 15.247(a)(2)                                       | Spectrum Bandwidth of a Direct Sequence Spread Spectrum System<br>Limit: min. 500kHz   | PASS          | Meet the requirement of limit   |
| 15.247(b)  | Maximum Peak Output Power<br>Limit: max. 30dBm   | PASS          | Meet the requirement of limit   |
| 15.247(c)  | Radiated Emissions<br>Limit: Table 15.209  | PASS          | Meet the requirement of limit<br>Minimum passing margin is -1.3dBuV at 5440.00MHz |
| 15.247(d)  | Power Spectral Density<br>Limit: max. 8dBm   | PASS          | Meet the requirement of limit   |
| 15.247(c)  | Band Edge Measurement<br>Limit: 20dB less than the peak value of fundamental frequency | PASS          | Meet the requirement of limit   |





### 3. GENERAL INFORMATION

#### 3.1 GENERAL DESCRIPTION OF EUT

|                           |   |
|---------------------------|---|
| <b>PRODUCT</b>            | Wireless Dual Band Enterprise Access Point  |
| <b>MODEL NO.</b>          | RBT3K-AG, RBT3K-AG-G  |
| <b>POWER SUPPLY</b>       | 5VDC from AC adapter  |
| <b>MODULATION</b>         | DSSS, OFDM  |
| <b>TRANSFER RATE</b>      | 802.11b and draft 802.11g:<br>1/2/5.5/6/9/11/12/18/24/36/48/54Mbps<br>802.11a:6 to 54Mbps (Turbo mode: up to 108Mbps *see note 1) |
| <b>FREQUENCY RANGE</b>    | 802.11b and draft 802.11g: 2400MHz ~ 2483.5MHz<br>802.11a: 5.15~5.35GHz and 5.725~5.850GHz  |
| <b>NUMBER OF CHANNEL</b>  | 802.11b and draft 802.11g: 11<br>802.11a: 13 for Normal mode / 5 for Turbo mode   |
| <b>CHANNEL SPACING</b>    | 802.11b and draft 802.11g: 5MHz<br>802.11a: 20MHz for Normal mode / 40MHz for Turbo mode  |
| <b>OUTPUT POWER</b>       | 802.11b: 18.3dBm / draft 802.11g: 18.2dBm<br>802.11a: 21.0dBm   |
| <b>DATA CABLE</b>         | NA  |
| <b>ANTENNA TYPE</b>       | Dual-Band Omni-Directional Antenna  |
| <b>I/O PORTS</b>          | RJ 45 (POE) Port x 1, Console Port x 1  |
| <b>ASSOCIATED DEVICES</b> | NA  |

**NOTE:**

1. This EUT is capable of providing data rates of up to 108Mbps in Turbo Mode depending upon reception quality.



2. There is one antenna provided to this EUT, please refer to the following table:

| Model No.                 |
|---------------------------|
| R0322-066(without switch) |

3. The EUT was powered either adapter or POE (Power Over Ethernet):

| Adapter:              |                         |
|-----------------------|-------------------------|
| <b>Brand:</b>         | DELTA                   |
| <b>Model No.:</b>     | ADP-15KB REV:C          |
| <b>Input power :</b>  | 100-240Vac 0.5A 50-60Hz |
| <b>Output power :</b> | 5.1Vdc 3.0A             |

| POE:  |                          |
|---|--------------------------|
| <b>Brand:</b>   | 3COM                     |
| <b>Model No.:</b>   | PW130                    |
| <b>Input power :</b>  | 100-250Vac 50-60Hz 500mA |
| <b>Output power :</b>   | 48Vdc 420mA              |
| <b>*The POE supplied power to EUT via POE port, only used on testing.</b> |                          |

4. Dual-band, the EUT communicates with Wireless-A (802.11a), Wireless-B, (802.11b), and Wireless-G (draft 802.11g) wireless networks.
5. For more detailed features description, please refer to the manufacturer's specifications or User's Manual.



### 3.2 DESCRIPTION OF TEST MODES

For 802.11b: Eleven channels are provided to this EUT.

| Channel | Frequency | Channel | Frequency |
|---------|-----------|---------|-----------|
| 1       | 2412 MHz  | 7       | 2442 MHz  |
| 2       | 2417 MHz  | 8       | 2447 MHz  |
| 3       | 2422 MHz  | 9       | 2452 MHz  |
| 4       | 2427 MHz  | 10      | 2457 MHz  |
| 5       | 2432 MHz  | 11      | 2462 MHz  |
| 6       | 2437 MHz  |         |           |

**NOTE:**

1. Below 1 GHz, the channel 1, 6, and 11 were pre-tested in chamber. The channel 11, worst case one, was chosen for final test.
2. Above 1 GHz, the channel 1, 6, and 11 were tested individually. The EUT with adapter and with POE were pre-tested in chamber. The EUT with adapter, worst case one, was chosen for final test.
3. Transfer rate, 11Mbps with CCK technique and 6Mbps with OFDM technique, the worst case, were chosen for final test.
4. Test result A is for CCK technique and test result B is for OFDM technique which presented in Section 4.

For 802.11a: Thirteen channels are provided to this EUT for Normal mode.

| Channel | Frequency | Channel | Frequency |
|---------|-----------|---------|-----------|
| 1       | 5180 MHz  | 8       | 5320 MHz  |
| 2       | 5200 MHz  | 9       | 5745MHz   |
| 3       | 5220 MHz  | 10      | 5765MHz   |
| 4       | 5240 MHz  | 11      | 5785MHz   |
| 5       | 5260 MHz  | 12      | 5805MHz   |
| 6       | 5280 MHz  | 13      | 5825MHz   |
| 7       | 5300 MHz  |         |           |

Five channels are provided to this EUT for Turbo Mode.

| Channel | Frequency | Channel | Frequency |
|---------|-----------|---------|-----------|
| 1       | 5210 MHz  | 4       | 5760MHz   |
| 2       | 5250 MHz  | 5       | 5800MHz   |
| 3       | 5290 MHz  |         |           |

**NOTE:**

- 1..The EUT was tested in both normal mode (channel bandwidth of approximately 30MHz) and turbo mode (channel bandwidth of approximately 60MHz).
2. "Normal Mode" allows data rates of up to 54Mbps. The device was, therefore, tested in Normal mode at the data rate that produced the highest output power for normal mode (6Mbps).
3. "Turbo Mode" allows data rates of up to 108Mbps. At data rates higher than 12Mbps the PA gain is reduced to improve signal fidelity. The device was, therefore, tested in turbo mode at the data rate that produced the highest output power for turbo mode (12Mbps).
4. Channel 1, 4, 5, 8, 9, 11 and 13 are the closest frequencies to the band edge, were chosen for final test of Normal Mode.
5. Channel 1 ~ 5 were chosen for final test of turbo mode.



### **3.3 GENERAL DESCRIPTION OF APPLIED STANDARDS**

The EUT is a Wireless Dual Band Enterprise Access Point According to the specifications of the manufacturer, it must comply with the requirements of the following standards:

**47 CFR Part 15, Subpart C. (15.247),  
Subpart E (15.407). ANSI C63.4 : 1992**

All tests have been performed and recorded as per the above standards.

**NOTE:** The EUT is also considered as a kind of computer peripheral, because the connection to computer is necessary for typical use. It has been verified to comply with the requirements of 47CFR Part 15, Subpart B, Class B (DoC). The test report has been issued separately.



### 3.4 DESCRIPTION OF SUPPORT UNITS

The EUT has been tested as an independent unit together with other necessary accessories or support units. The following support units or accessories were used to form a representative test configuration during the tests.

| No. | Product  | Brand | Model No. | Serial No.               | FCC ID  |
|-----|----------|-------|-----------|--------------------------|---------|
| 1   | NOTEBOOK | DELL  | PP01L     | TW-09C748-12800-1A3-1999 | FCC DoC |

| No. | Signal cable description |
|-----|--------------------------|
| 1   | NA                       |

Note: 1. All power cords of the above support units are unshielded (1.8m).

**WITH ADAPTER:**

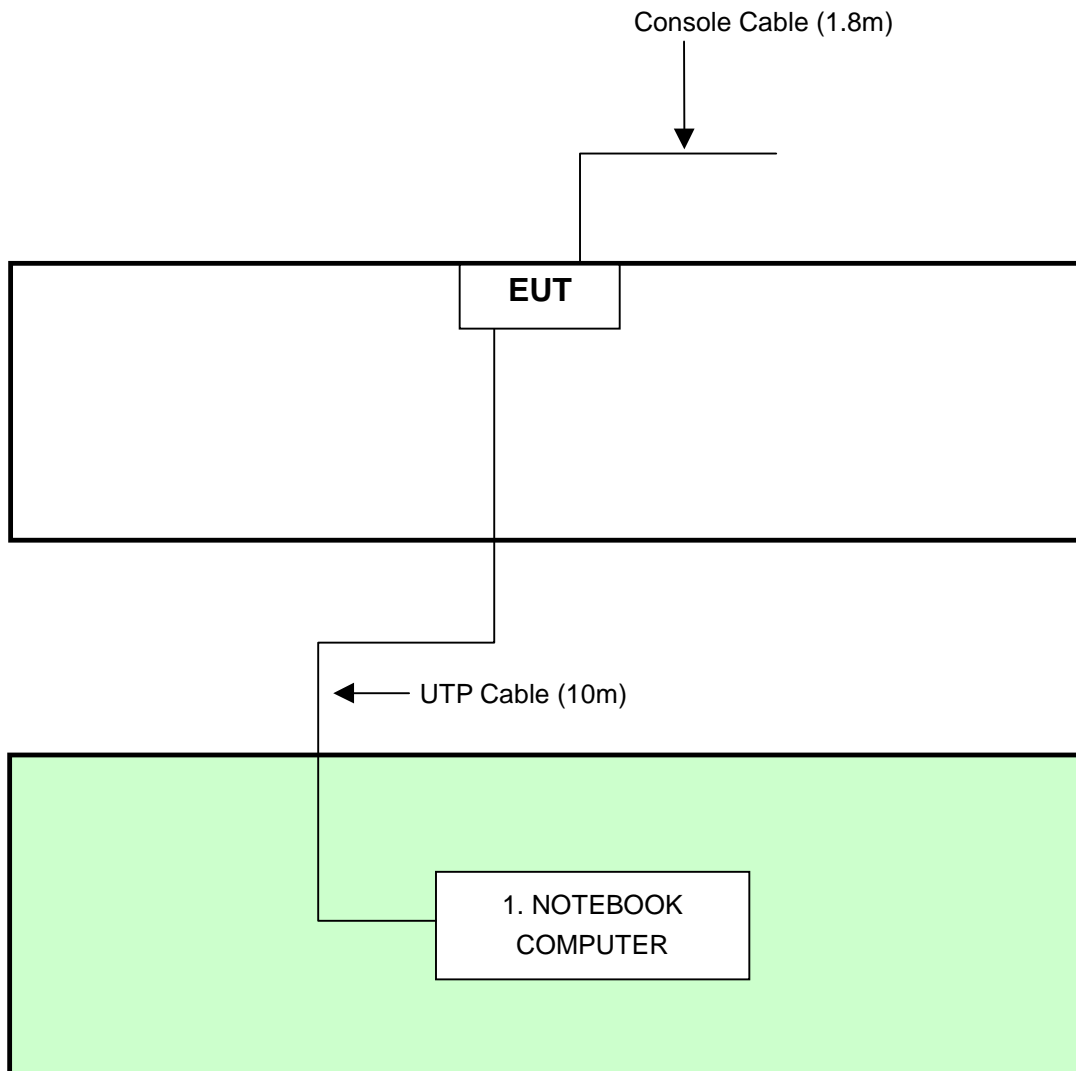

- NOTE:** 1. Support unit 1 was kept in the control room during the test.  
2. Please refer to the photos of test configuration in Item 5 also.

**WITH POE:**

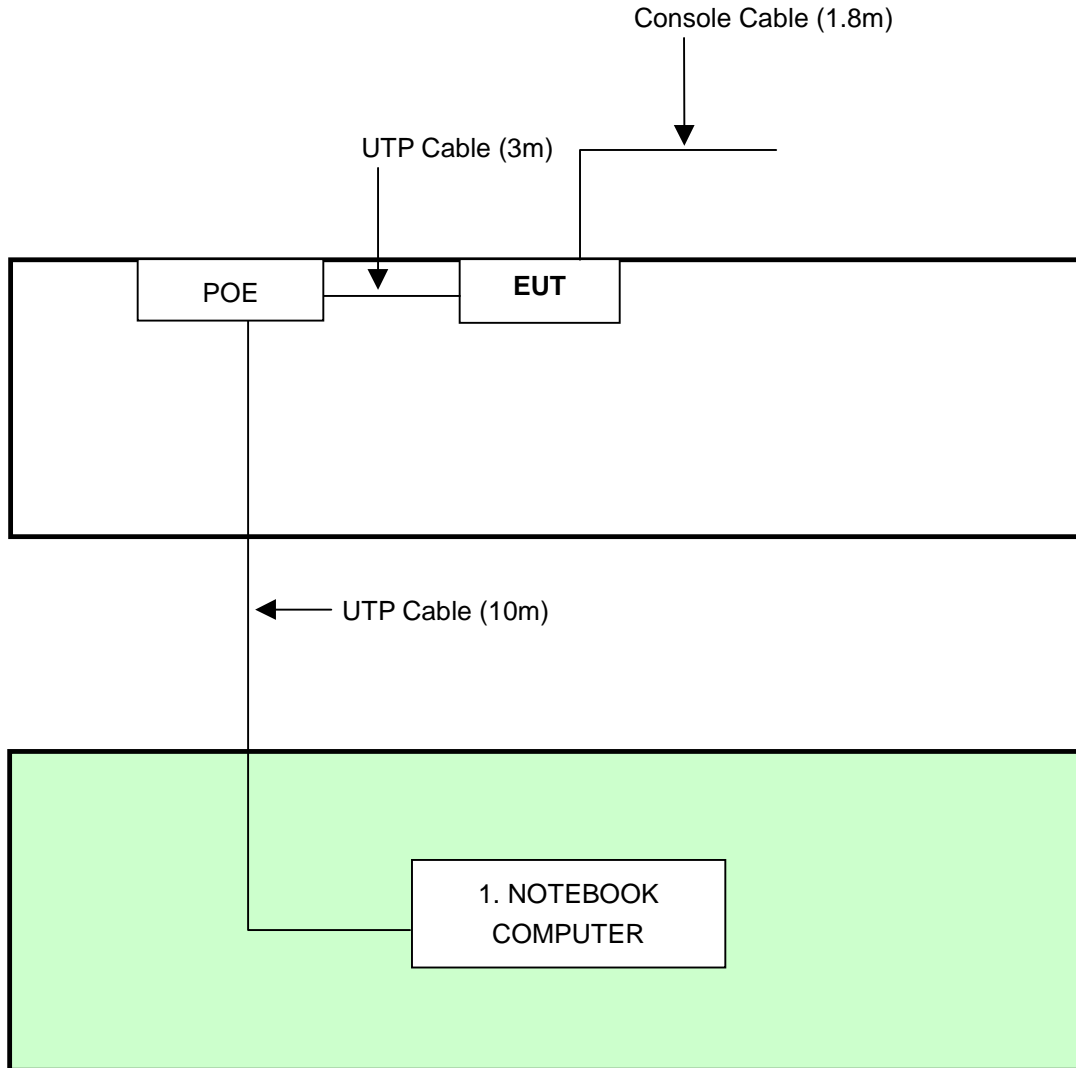

- NOTE:** 1. Support unit 1 was kept in the control room during the test.  
2. Please refer to the photos of test configuration in Item 5 also.



## 4. TEST TYPES AND RESULTS (FOR PART 802.11b)

### 4.1 CONDUCTED EMISSION MEASUREMENT

#### 4.1.1 LIMITS OF CONDUCTED EMISSION MEASUREMENT

| FREQUENCY OF EMISSION (MHz) | CONDUCTED LIMIT (dB $\mu$ V) |          |
|-----------------------------|------------------------------|----------|
|                             | Quasi-peak                   | Average  |
| 0.15-0.5                    | 66 to 56                     | 56 to 46 |
| 0.5-5                       | 56                           | 46       |
| 5-30                        | 60                           | 50       |

- NOTE:**
1. The lower limit shall apply at the transition frequencies.
  2. The limit decreases in line with the logarithm of the frequency in the range of 0.15 to 0.50 MHz.
  3. All emanations from a class A/B digital device or system, including any network of conductors and apparatus connected thereto, shall not exceed the level of field strengths specified above.

#### 4.1.2 TEST INSTRUMENTS

| DESCRIPTION & MANUFACTURER        | MODEL NO. | SERIAL NO.  | CALIBRATED UNTIL |
|-----------------------------------|-----------|-------------|------------------|
| ROHDE & SCHWARZ<br>Test Receiver  | ESCS 30   | 847124/029  | Nov. 17, 2003    |
| ROHDE & SCHWARZ LISN<br>(for EUT) | ESHS-Z5   | 848773/004  | Nov. 13, 2003    |
| KYORITSU LISN (for peripheral)    | KNW-407   | 8/1395/12   | Jul. 23, 2004    |
| RF Cable (JETBAO)                 | RG233/U   | Cable_CA_01 | Jul. 03, 2004    |
| Terminator(for KYORITSU)          | 50        | 3           | Apr. 11, 2004    |
| Software                          | Cond-V2e  | NA          | NA               |

- NOTE:**
1. The calibration interval of the above test instruments is 12 months and the calibrations are traceable to NML/ROC and NIST/USA.
  2. The test was performed in ADT Shielded Room No. A.
  3. The VCCI Con A Registration No. is C-817.





#### 4.1.3 TEST PROCEDURES

- a. The EUT was placed 0.4 meters from the conducting wall of the shielded room with EUT being connected to the power mains through a line impedance stabilization network (LISN). Other support units were connected to the power mains through another LISN. The two LISNs provide 50 ohm/ 50uH of coupling impedance for the measuring instrument.
- b. Both lines of the power mains connected to the EUT were checked for maximum conducted interference.
- c. The frequency range from 150 kHz to 30 MHz was searched. Emission levels over 10dB under the prescribed limits could not be reported

#### 4.1.4 DEVIATION FROM TEST STANDARD

No deviation

#### 4.1.5 TEST SETUP

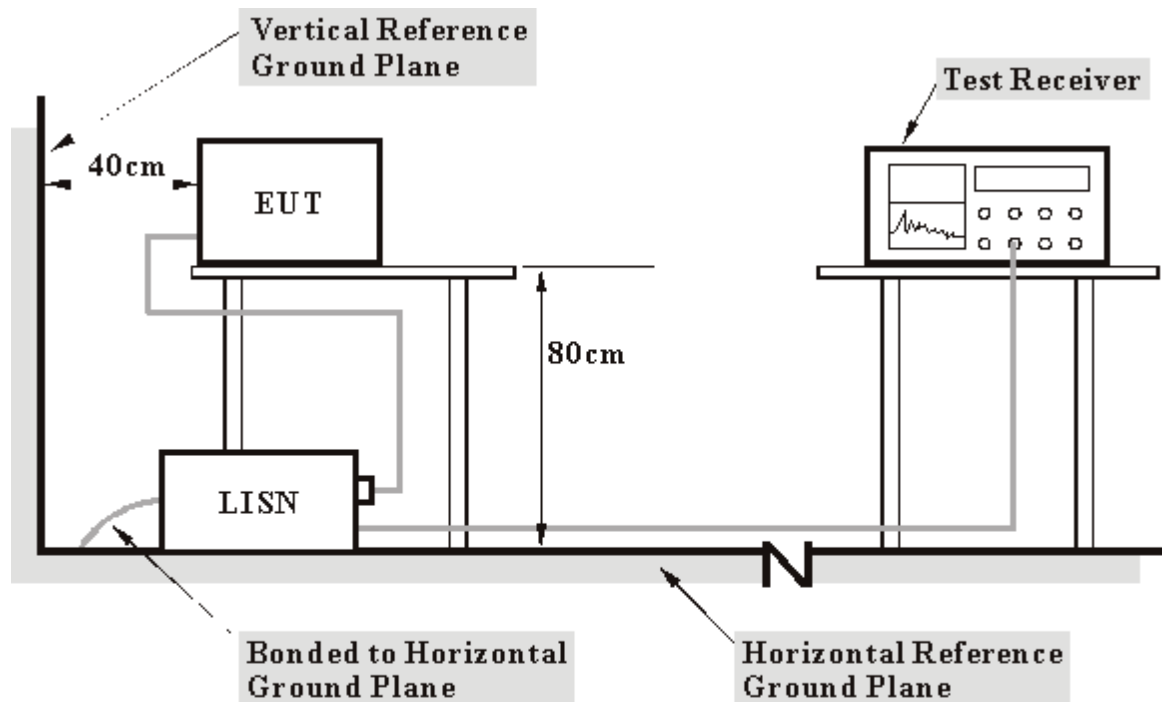

- Note:**
1. Support units were connected to second LISN.
  2. Both of LISNs (AMN) 80 cm from EUT and at the least 80 cm from other units and other metal planes support units.

For the actual test configuration, please refer to the related item – Photographs of the Test Configuration.

#### 4.1.6 EUT OPERATING CONDITIONS

- a. Placed the EUT on the testing table.
- b. Prepared another computer system to act as a communication partner and placed it outside of testing area.
- c. The communication partner run a test program to enable EUT under transmission/receiving condition continuously at specific channel frequency via RJ 45 cable and wireless.
- d. The communication partner sent data to EUT by command "PING".



4.1.7 TEST RESULTS

|                                 |  |                      |           |
|---------------------------------|--|----------------------|-----------|
| <b>EUT</b>                      | Wireless Dual Band Enterprise Access Point | <b>MODEL</b>         | RBT3K-AG  |
| <b>MODE</b>                     | With Adapter, Channel 11                   | <b>6dB BANDWIDTH</b> | 9 kHz     |
| <b>INPUT POWER (SYSTEM)</b>     | 120Vac, 60Hz                               | <b>PHASE</b>         | Line (L)  |
| <b>ENVIRONMENTAL CONDITIONS</b> | 27deg. C, 69%RH, 976 hPa                   | <b>TESTED BY</b>     | Lary Peng |

| No | Freq. [MHz] | Corr. Factor [dB] | Reading Value [dB (uV)] |     | Emission Level [dB (uV)] |     | Limit [dB (uV)] |       | Margin (dB) |     |
|----|-------------|-------------------|-------------------------|-----|--------------------------|-----|-----------------|-------|-------------|-----|
|    |             |                   | Q.P.                    | AV. | Q.P.                     | AV. | Q.P.            | AV.   | Q.P.        | AV. |
|    |             |                   |                         |     |                          |     |                 |       |             |     |
| 1  | 0.150       | 0.20              | 50.03                   | -   | 50.23                    | -   | 66.00           | 56.00 | -15.77      | -   |
| 2  | 0.244       | 0.20              | 39.66                   | -   | 39.86                    | -   | 61.97           | 51.97 | -22.11      | -   |
| 3  | 1.232       | 0.30              | 32.71                   | -   | 33.01                    | -   | 56.00           | 46.00 | -22.99      | -   |
| 4  | 2.576       | 0.33              | 20.91                   | -   | 21.24                    | -   | 56.00           | 46.00 | -34.76      | -   |
| 5  | 10.852      | 0.85              | 36.81                   | -   | 37.66                    | -   | 60.00           | 50.00 | -22.34      | -   |
| 6  | 15.715      | 1.11              | 45.53                   | -   | 46.64                    | -   | 60.00           | 50.00 | -13.36      | -   |

- NOTES: (1) "-": Undetectable  
 (2) Q.P. and AV. are abbreviations of quasi-peak and average.  
 (3) "-": The Quasi-peak reading value also meets an average limit, thus measurement with the average detector is unnecessary.  
 (4) The emission levels of other frequencies were very low against the limit.  
 (5) Correction Factor = Insertion loss + Cable loss  
 (6) Margin value = Emission level - Limit value

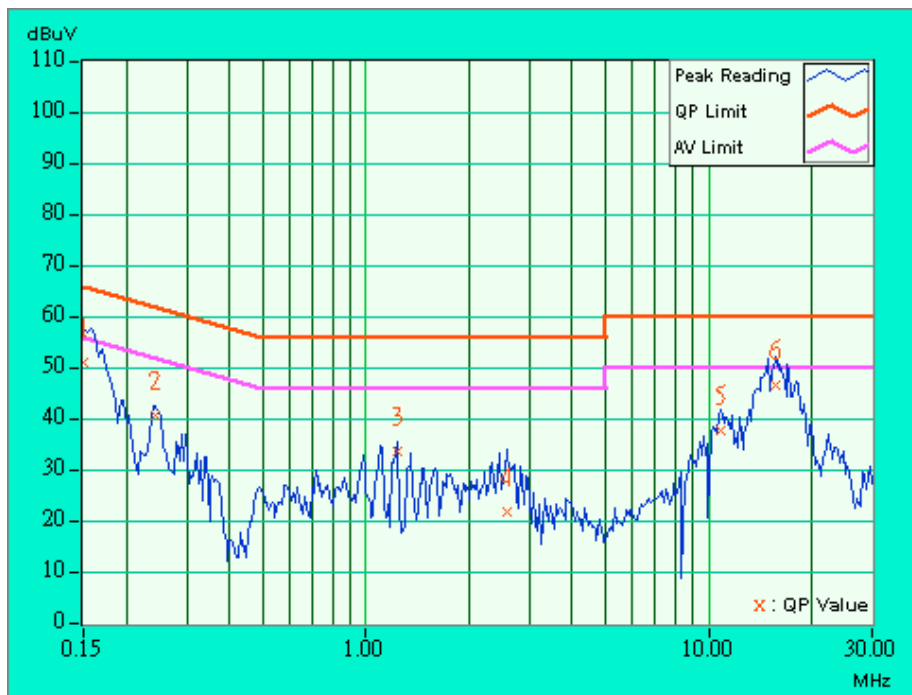



|                                 |  |                      |             |
|---------------------------------|--|----------------------|-------------|
| <b>EUT</b>                      | Wireless Dual Band Enterprise Access Point | <b>MODEL</b>         | RBT3K-AG    |
| <b>MODE</b>                     | With Adapter, Channel 11                   | <b>6dB BANDWIDTH</b> | 9 kHz       |
| <b>INPUT POWER (SYSTEM)</b>     | 120Vac, 60Hz                               | <b>PHASE</b>         | Neutral (N) |
| <b>ENVIRONMENTAL CONDITIONS</b> | 27deg. C, 69%RH, 976 hPa                   | <b>TESTED BY</b>     | Lary Peng   |

| No | Freq. [MHz] | Corr. Factor (dB) | Reading Value [dB (uV)] |       | Emission Level [dB (uV)] |       | Limit [dB (uV)] |       | Margin (dB) |       |
|----|-------------|-------------------|-------------------------|-------|--------------------------|-------|-----------------|-------|-------------|-------|
|    |             |                   | Q.P.                    | AV.   | Q.P.                     | AV.   | Q.P.            | AV.   | Q.P.        | AV.   |
|    |             |                   | 1                       | 0.150 | 0.20                     | 49.97 | -               | 50.17 | -           | 66.00 |
| 2  | 0.240       | 0.20              | 40.06                   | -     | 40.26                    | -     | 62.10           | 52.10 | -21.84      | -     |
| 3  | 1.220       | 0.30              | 32.45                   | -     | 32.75                    | -     | 56.00           | 46.00 | -23.25      | -     |
| 4  | 11.105      | 0.74              | 37.36                   | -     | 38.10                    | -     | 60.00           | 50.00 | -21.90      | -     |
| 5  | 15.441      | 0.90              | 45.93                   | -     | 46.83                    | -     | 60.00           | 50.00 | -13.17      | -     |
| 6  | 23.023      | 0.96              | 29.50                   | -     | 30.46                    | -     | 60.00           | 50.00 | -29.54      | -     |

- NOTES: (1) "-": Undetectable  
 (2) Q.P. and AV. are abbreviations of quasi-peak and average.  
 (3) "-": The Quasi-peak reading value also meets an average limit, thus measurement with the average detector is unnecessary.  
 (4) The emission levels of other frequencies were very low against the limit.  
 (5) Correction Factor = Insertion loss + Cable loss  
 (6) Margin value = Emission level - Limit value

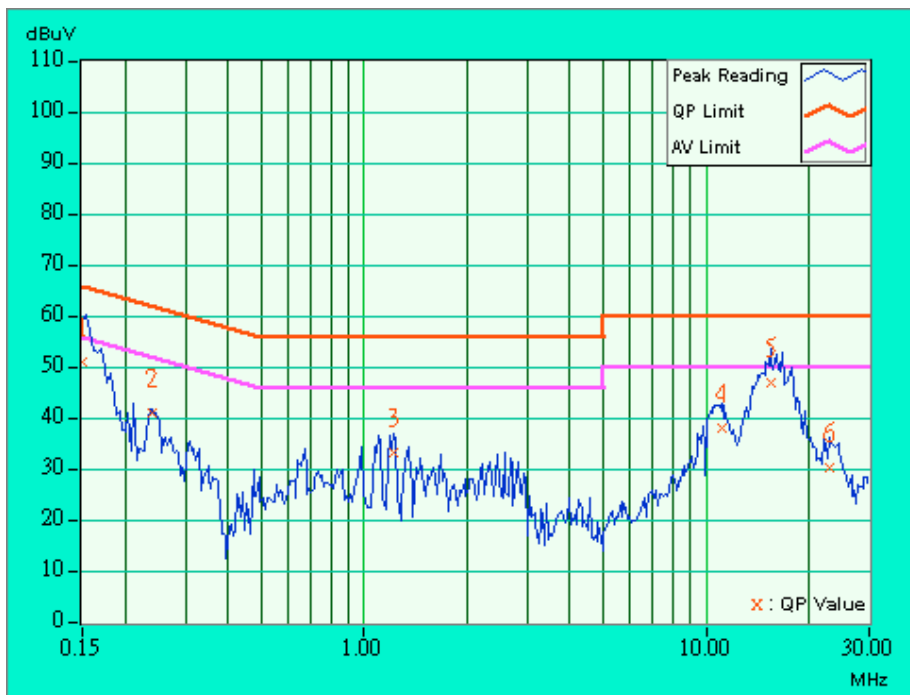



### 4.1.8 TEST RESULTS

|                                 |  |                      |           |
|---------------------------------|--|----------------------|-----------|
| <b>EUT</b>                      | Wireless Dual Band Enterprise Access Point | <b>MODEL</b>         | RBT3K-AG  |
| <b>MODE</b>                     | With POE, Channel 11                       | <b>6dB BANDWIDTH</b> | 9 kHz     |
| <b>INPUT POWER (SYSTEM)</b>     | 120Vac, 60Hz                               | <b>PHASE</b>         | Line (L)  |
| <b>ENVIRONMENTAL CONDITIONS</b> | 27deg. C, 69%RH, 976 hPa                   | <b>TESTED BY</b>     | Lary Peng |

| No       | Freq. [MHz]  | Corr. Factor [dB] | Reading Value [dB (uV)] |       | Emission Level [dB (uV)] |       | Limit [dB (uV)] |              | Margin (dB)   |       |
|----------|--------------|-------------------|-------------------------|-------|--------------------------|-------|-----------------|--------------|---------------|-------|
|          |              |                   | Q.P.                    | AV.   | Q.P.                     | AV.   | Q.P.            | AV.          | Q.P.          | AV.   |
|          |              |                   | 1                       | 0.158 | 0.20                     | 52.78 | -               | 52.98        | -             | 65.58 |
| 2        | 0.670        | 0.24              | 40.31                   | -     | 40.55                    | -     | 56.00           | 46.00        | -15.45        | -     |
| <b>3</b> | <b>1.338</b> | <b>0.30</b>       | <b>45.12</b>            | -     | <b>45.42</b>             | -     | <b>56.00</b>    | <b>46.00</b> | <b>-10.58</b> | -     |
| 4        | 1.673        | 0.30              | 42.80                   | -     | 43.10                    | -     | 56.00           | 46.00        | -12.90        | -     |
| 5        | 9.473        | 0.76              | 44.31                   | -     | 45.07                    | -     | 60.00           | 50.00        | -14.93        | -     |
| 6        | 14.570       | 1.07              | 48.25                   | -     | 49.32                    | -     | 60.00           | 50.00        | -10.68        | -     |

- NOTES: (1) "\*\*": Undetectable  
 (2) Q.P. and AV. are abbreviations of quasi-peak and average.  
 (3) "-": The Quasi-peak reading value also meets an average limit, thus measurement with the average detector is unnecessary.  
 (4) The emission levels of other frequencies were very low against the limit.  
 (5) Correction Factor = Insertion loss + Cable loss  
 (6) Margin value = Emission level - Limit value

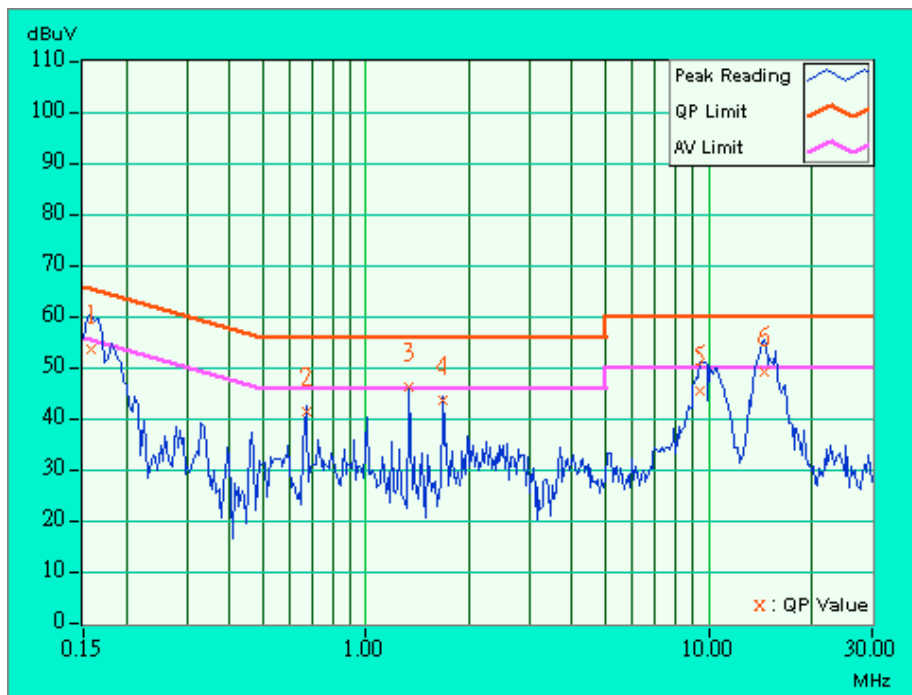



|                                 |  |                      |             |
|---------------------------------|--|----------------------|-------------|
| <b>EUT</b>                      | Wireless Dual Band Enterprise Access Point | <b>MODEL</b>         | RBT3K-AG    |
| <b>MODE</b>                     | With POE, Channel 11                       | <b>6dB BANDWIDTH</b> | 9 kHz       |
| <b>INPUT POWER (SYSTEM)</b>     | 120Vac, 60Hz                               | <b>PHASE</b>         | Neutral (N) |
| <b>ENVIRONMENTAL CONDITIONS</b> | 27deg. C, 69%RH, 976 hPa                   | <b>TESTED BY</b>     | Lary Peng   |

| No | Freq. [MHz] | Corr. Factor | Reading Value [dB (uV)] |     | Emission Level [dB (uV)] |     | Limit [dB (uV)] |       | Margin (dB) |     |
|----|-------------|--------------|-------------------------|-----|--------------------------|-----|-----------------|-------|-------------|-----|
|    |             | (dB)         | Q.P.                    | AV. | Q.P.                     | AV. | Q.P.            | AV.   | Q.P.        | AV. |
|    |             |              |                         |     |                          |     |                 |       |             |     |
| 1  | 0.158       | 0.20         | 52.77                   | -   | 52.97                    | -   | 65.58           | 55.58 | -12.61      | -   |
| 2  | 0.666       | 0.24         | 38.11                   | -   | 38.35                    | -   | 56.00           | 46.00 | -17.65      | -   |
| 3  | 1.338       | 0.30         | 44.81                   | -   | 45.11                    | -   | 56.00           | 46.00 | -10.89      | -   |
| 4  | 1.673       | 0.30         | 42.54                   | -   | 42.84                    | -   | 56.00           | 46.00 | -13.16      | -   |
| 5  | 9.676       | 0.68         | 45.71                   | -   | 46.39                    | -   | 60.00           | 50.00 | -13.61      | -   |
| 6  | 14.727      | 0.89         | 48.21                   | -   | 49.10                    | -   | 60.00           | 50.00 | -10.90      | -   |

- NOTES: (1) "-": Undetectable  
 (2) Q.P. and AV. are abbreviations of quasi-peak and average.  
 (3) "-": The Quasi-peak reading value also meets an average limit, thus measurement with the average detector is unnecessary.  
 (4) The emission levels of other frequencies were very low against the limit.  
 (5) Correction Factor = Insertion loss + Cable loss  
 (6) Margin value = Emission level - Limit value

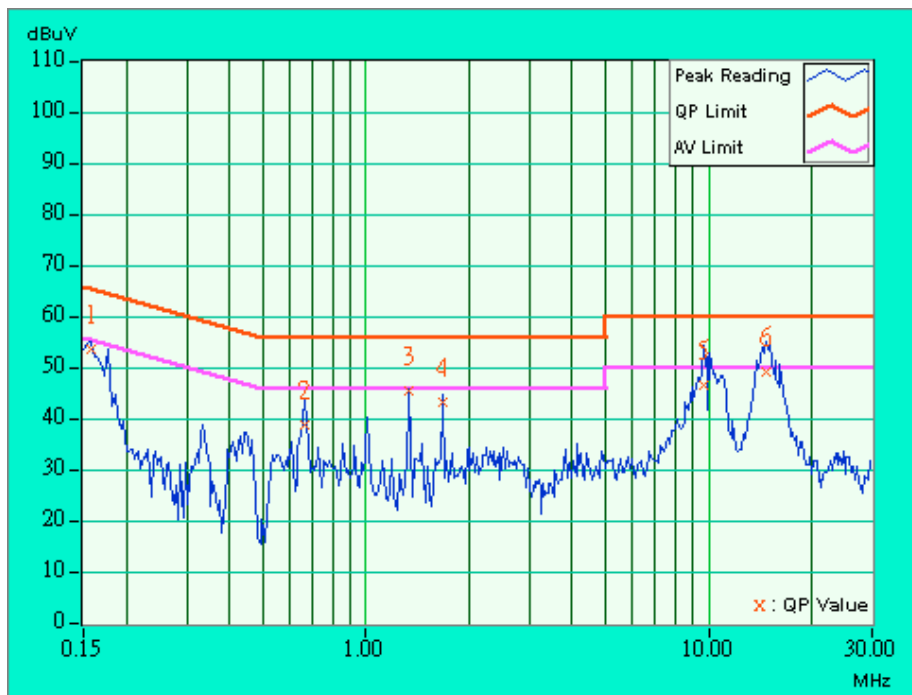



## 4.2 RADIATED EMISSION MEASUREMENT

### 4.2.1 LIMITS OF RADIATED EMISSION MEASUREMENT

Emissions radiated outside of the specified bands, shall be according to the general radiated limits in 15.209 as following:

| Frequencies<br>(MHz) | Field strength<br>(microvolts/meter) | Measurement distance<br>(meters) |
|----------------------|--------------------------------------|----------------------------------|
| 0.009-0.490          | 2400/F(kHz)                          | 300                              |
| 0.490-1.705          | 24000/F(kHz)                         | 30                               |
| 1.705-30.0           | 30                                   | 30                               |
| 30-88                | 100                                  | 3                                |
| 88-216               | 150                                  | 3                                |
| 216-960              | 200                                  | 3                                |
| Above 960            | 500                                  | 3                                |

**NOTE:**

1. The lower limit shall apply at the transition frequencies.
2. Emission level (dBuV/m) = 20 log Emission level (uV/m).
3. As shown in 15.35(b), for frequencies above 1000MHz, the field strength limits are based on average detector, however, the peak field strength of any emission shall not exceed the maximum permitted average limits, specified above by more than 20dB under any condition of modulation.



#### 4.2.2 TEST INSTRUMENTS

| DESCRIPTION & MANUFACTURER            | MODEL NO. | SERIAL NO.              | CALIBRATED UNTIL |
|---------------------------------------|-----------|-------------------------|------------------|
| HP Spectrum Analyzer                  | 8594ER    | 3829U04676              | Jul. 14, 2004    |
| ADVANTEST Spectrum Analyzer           | R3271A    | 85060311                | May 21, 2004     |
| CHASE RF Pre_Amplifier                | CPA9232   | 1057                    | Apr. 24, 2004    |
| HP Pre_Amplifier                      | 8449B     | 3008A01281              | June 27, 2004    |
| ROHDE & SCHWARZ<br>Test Receiver      | ESVS 10   | 849231 /019             | Nov. 03, 2003    |
| CHASE Broadband Antenna               | CBL6111c  | 2730                    | Jul 17, 2004     |
| Schwarzbeck Horn_Antenna              | 3115      | 5619                    | Jul. 17, 2004    |
| Schwarzbeck Horn_Antenna              | BBHA 9170 | BBHA9170192             | Feb. 16, 2005    |
| SCHWARZBECK Tunable<br>Dipole Antenna | UHAP      | 897                     | Mar. 07, 2005    |
| SCHWARZBECK Tunable<br>Dipole Antenna | VHAP      | 880                     | Mar. 07, 2005    |
| RF Switches (ARNITSU)                 | CS-201    | 1565157                 | Dec. 01, 2003    |
| RF CABLE (Chaintek) 1GHz-20GHz        | SF102     | 22054-2                 | Feb. 10. 2004    |
| RF Cable(RICHTEC)                     | 9913-30M  | STCCAB-30M-<br>1GHz-021 | Nov. 5, 2003     |
| Software                              | AS60P8    | NA                      | NA               |
| CHANCE MOST<br>Antenna Tower          | AT-100    | 0203                    | NA               |
| CHANCE MOST Turn Table                | TT-100    | 0203                    | NA               |

Note: 1. The calibration interval of the above test instruments is 12 months (36 months for Tunable Dipole Antenna) and the calibrations are traceable to NML/ROC and NIST/USA.

2. \* = These equipment are used for the final measurement.
3. The horn antenna and HP preamplifier (model: 8449B) are used only for the measurement of emission frequency above 1GHz if tested.
4. The test was performed in ADT Open Site No. C.
5. The FCC Site Registration No. is 656396.
6. The VCCI Site Registration No. is R-1626.
7. The CANADA Site Registration No. is IC 3789-C.





#### 4.2.3 TEST PROCEDURES

- a. The EUT was placed on the top of a rotating table 0.8 meters above the ground at a 10 meter open area test site. The table was rotated 360 degrees to determine the position of the highest radiation.
- b. The EUT was set 3 meters away from the interference-receiving antenna, which was mounted on the top of a variable-height antenna tower.
- c. The antenna is a broadband antenna, and its height is varied from one meter to four meters above the ground to determine the maximum value of the field strength. Both horizontal and vertical polarizations of the antenna are set to make the measurement.
- d. For each suspected emission, the EUT was arranged to its worst case and then the antenna was tuned to heights from 1 meter to 4 meters and the rotatable table was turned from 0 degrees to 360 degrees to find the maximum reading.
- e. The test-receiver system was set to Peak Detect Function and Specified Bandwidth with Maximum Hold Mode.
- f. If the emission level of the EUT in peak mode was 10 dB lower than the limit specified, then testing could be stopped and the peak values of the EUT would be reported. Otherwise the emissions that did not have 10 dB margin would be re-tested one by one using the quasi-peak method or average method as specified and then reported in Data sheet peak mode and QP mode.

**NOTE:**

1. The resolution bandwidth and video bandwidth of test receiver/spectrum analyzer is 120kHz for Quasi-peak detection at frequency below 1GHz.
2. The resolution bandwidth and video bandwidth of test receiver/spectrum analyzer is 1 MHz for Peak detection (PK) at frequency above 1GHz.
3. The resolution bandwidth of test receiver/spectrum analyzer is 1 MHz and the video bandwidth is 300 Hz for Average detection (AV) at frequency above 1GHz.

#### 4.2.4 DEVIATION FROM TEST STANDARD

No deviation

#### 4.2.5 TEST SETUP

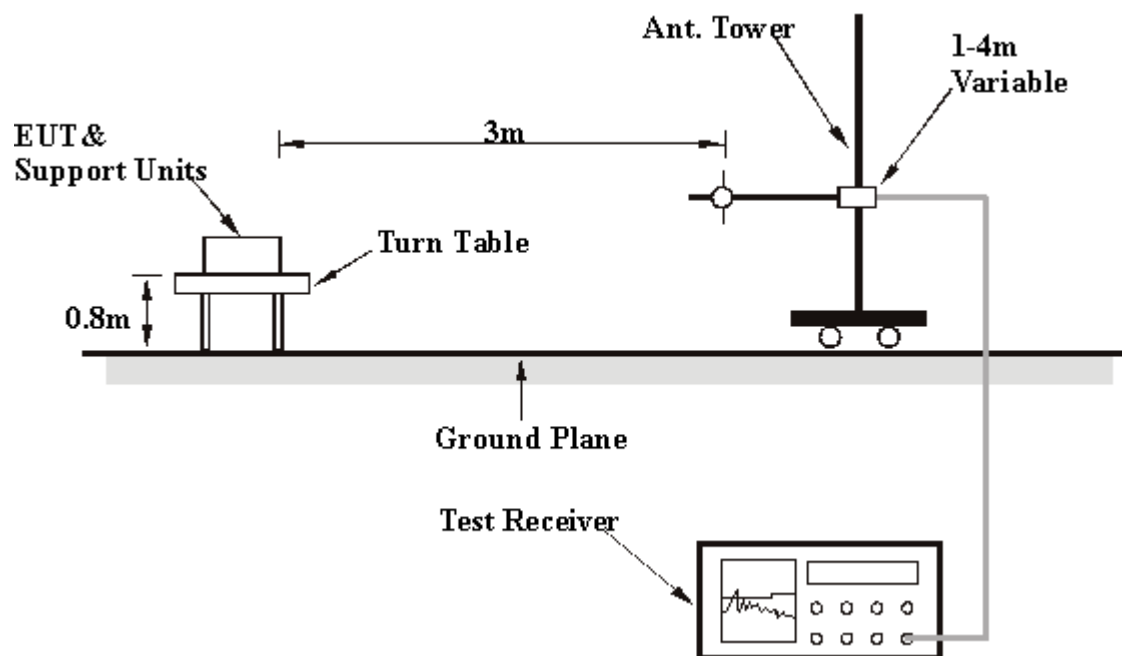

For the actual test configuration, please refer to the related item – Photographs of the Test Configuration.

#### 4.2.6 EUT OPERATING CONDITIONS

Same as 4.1.6



## 4.2.7 TEST RESULTS

|                                 |  |                          |                |
|---------------------------------|--|--------------------------|----------------|
| <b>EUT</b>                      | Wireless Dual Band Enterprise Access Point | <b>MODEL</b>             | RBT3K-AG       |
| <b>MODE</b>                     | With Adapter, Channel 11                   | <b>FREQUENCY RANGE</b>   | Below 1000 MHz |
| <b>INPUT POWER (SYSTEM)</b>     | 120Vac, 60Hz                               | <b>DETECTOR FUNCTION</b> | Quasi-Peak     |
| <b>ENVIRONMENTAL CONDITIONS</b> | 29deg. C, 56%RH, 976 hPa                   | <b>TESTED BY</b>         | Eric Lee       |

**ANTENNA POLARITY & TEST DISTANCE: HORIZONTAL AT 3 M**

| No. | Freq. (MHz) | Emission Level (dBuV/m) | Limit (dBuV/m) | Margin (dB) | Antenna Height (m) | Table Angle (Degree) | Raw Value (dBuV) | Correction Factor (dB/m) |
|-----|-------------|-------------------------|----------------|-------------|--------------------|----------------------|------------------|--------------------------|
| 1   | 40.36       | 29.9 QP                 | 40.00          | -10.10      | 1.58 H             | 54                   | 16.30            | 13.60                    |
| 2   | 45.60       | 24.1 QP                 | 40.00          | -15.90      | 1.06 H             | 35                   | 13.20            | 10.90                    |
| 3   | 125.12      | 25.9 QP                 | 43.50          | -17.60      | 1.54 H             | 356                  | 13.90            | 12.00                    |
| 4   | 220.23      | 28.0 QP                 | 46.00          | -18.00      | 1.82 H             | 9                    | 18.60            | 9.40                     |
| 5   | 250.00      | 29.3 QP                 | 46.00          | -16.70      | 1.28 H             | 193                  | 16.30            | 13.00                    |
| 6   | 351.56      | 30.8 QP                 | 46.00          | -15.20      | 1.29 H             | 99                   | 15.30            | 15.50                    |
| 7   | 375.00      | 29.2 QP                 | 46.00          | -16.80      | 1.01 H             | 152                  | 13.00            | 16.20                    |
| 8   | 395.89      | 37.6 QP                 | 46.00          | -8.40       | 1.22 H             | 56                   | 20.60            | 17.00                    |
| 9   | 480.00      | 30.9 QP                 | 46.00          | -15.10      | 1.45 H             | 30                   | 12.00            | 18.90                    |
| 10  | 499.93      | 33.9 QP                 | 46.00          | -12.10      | 1.96 H             | 356                  | 14.60            | 19.30                    |
| 11  | 528.30      | 41.7 QP                 | 46.00          | -4.30       | 1.87 H             | 58                   | 22.10            | 19.60                    |
| 12  | 625.20      | 32.0 QP                 | 46.00          | -14.00      | 1.20 H             | 58                   | 10.30            | 21.70                    |

**ANTENNA POLARITY & TEST DISTANCE: VERTICAL AT 3 M**

| No. | Freq. (MHz) | Emission Level (dBuV/m) | Limit (dBuV/m) | Margin (dB) | Antenna Height (m) | Table Angle (Degree) | Raw Value (dBuV) | Correction Factor (dB/m) |
|-----|-------------|-------------------------|----------------|-------------|--------------------|----------------------|------------------|--------------------------|
| 1   | 46.20       | 26.9 QP                 | 40.00          | -13.10      | 1.58 V             | 54                   | 16.30            | 10.60                    |
| 2   | 60.23       | 28.7 QP                 | 40.00          | -11.30      | 1.05 V             | 349                  | 23.50            | 5.20                     |
| 3   | 70.24       | 23.9 QP                 | 40.00          | -16.10      | 1.18 V             | 7                    | 18.00            | 5.90                     |
| 4   | 125.02      | 32.9 QP                 | 43.50          | -10.60      | 1.35 V             | 66                   | 20.90            | 12.00                    |
| 5   | 220.30      | 29.7 QP                 | 46.00          | -16.30      | 1.69 V             | 356                  | 20.30            | 9.40                     |
| 6   | 250.21      | 29.2 QP                 | 46.00          | -16.80      | 1.57 V             | 89                   | 16.20            | 13.00                    |
| 7   | 308.12      | 25.6 QP                 | 46.00          | -20.40      | 1.52 V             | 3                    | 11.30            | 14.30                    |
| 8   | 352.00      | 30.5 QP                 | 46.00          | -15.50      | 1.25 V             | 119                  | 15.00            | 15.50                    |
| 9   | 375.00      | 30.2 QP                 | 46.00          | -15.80      | 1.47 V             | 8                    | 14.00            | 16.20                    |
| 10  | 396.11      | 32.9 QP                 | 46.00          | -13.10      | 1.40 V             | 267                  | 15.90            | 17.00                    |
| 11  | 500.00      | 35.3 QP                 | 46.00          | -10.70      | 1.74 V             | 58                   | 16.00            | 19.30                    |
| 12  | 528.36      | 41.2 QP                 | 46.00          | -4.80       | 1.01 V             | 58                   | 21.60            | 19.60                    |

- REMARKS:**
1. Emission level(dBuV/m)=Raw Value(dBuV) + Correction Factor(dB)
  2. Correction Factor(dB/m) = Antenna Factor (dB/m) + Cable Factor (dB)
  3. The other emission levels were very low against the limit.
  4. Margin value = Emission level – Limit value.
  5. The limit value is defined as per 15.247



|                                 |  |                          |                |
|---------------------------------|--|--------------------------|----------------|
| <b>EUT</b>                      | Wireless Dual Band Enterprise Access Point | <b>MODEL</b>             | RBT3K-AG       |
| <b>MODE</b>                     | With POE, Channel 11                       | <b>FREQUENCY RANGE</b>   | Below 1000 MHz |
| <b>INPUT POWER (SYSTEM)</b>     | 120Vac, 60Hz                               | <b>DETECTOR FUNCTION</b> | Quasi-Peak     |
| <b>ENVIRONMENTAL CONDITIONS</b> | 29deg. C, 56%RH, 976 hPa                   | <b>TESTED BY</b>         | Eric Lee       |

#### ANTENNA POLARITY & TEST DISTANCE: HORIZONTAL AT 3 M

| No. | Freq. (MHz) | Emission Level (dBuV/m) | Limit (dBuV/m) | Margin (dB) | Antenna Height (m) | Table Angle (Degree) | Raw Value (dBuV) | Correction Factor (dB/m) |
|-----|-------------|-------------------------|----------------|-------------|--------------------|----------------------|------------------|--------------------------|
| 1   | 52.00       | 24.9 QP                 | 40.00          | -15.10      | 2.17 H             | 25                   | 17.30            | 7.60                     |
| 2   | 60.25       | 22.1 QP                 | 40.00          | -17.90      | 1.68 H             | 0                    | 16.90            | 5.20                     |
| 3   | 124.95      | 25.4 QP                 | 43.50          | -18.10      | 1.13 H             | 169                  | 13.30            | 12.00                    |
| 4   | 220.16      | 24.8 QP                 | 46.00          | -21.20      | 1.00 H             | 42                   | 15.30            | 9.40                     |
| 5   | 249.85      | 27.6 QP                 | 46.00          | -18.40      | 1.42 H             | 199                  | 14.60            | 13.00                    |
| 6   | 264.49      | 32.9 QP                 | 46.00          | -13.10      | 1.39 H             | 68                   | 18.90            | 14.00                    |
| 7   | 351.63      | 29.4 QP                 | 46.00          | -16.60      | 1.07 H             | 190                  | 13.90            | 15.50                    |
| 8   | 374.98      | 31.8 QP                 | 46.00          | -14.20      | 1.10 H             | 140                  | 15.60            | 16.20                    |
| 9   | 500.13      | 33.4 QP                 | 46.00          | -12.60      | 1.35 H             | 29                   | 14.10            | 19.30                    |
| 10  | 527.53      | 39.0 QP                 | 46.00          | -7.00       | 1.84 H             | 323                  | 19.40            | 19.60                    |

#### ANTENNA POLARITY & TEST DISTANCE: VERTICAL AT 3 M

| No. | Freq. (MHz) | Emission Level (dBuV/m) | Limit (dBuV/m) | Margin (dB) | Antenna Height (m) | Table Angle (Degree) | Raw Value (dBuV) | Correction Factor (dB/m) |
|-----|-------------|-------------------------|----------------|-------------|--------------------|----------------------|------------------|--------------------------|
| 1   | 50.50       | 32.4 QP                 | 40.00          | -7.60       | 1.48 V             | 229                  | 24.10            | 8.30                     |
| 2   | 56.13       | 30.4 QP                 | 40.00          | -9.60       | 1.25 V             | 161                  | 24.10            | 6.40                     |
| 3   | 69.01       | 36.7 QP                 | 40.00          | -3.30       | 1.61 V             | 345                  | 31.00            | 5.80                     |
| 4   | 71.10       | 32.8 QP                 | 40.00          | -7.20       | 1.66 V             | 119                  | 26.70            | 6.10                     |
| 5   | 124.96      | 26.6 QP                 | 43.50          | -16.90      | 1.02 V             | 25                   | 14.60            | 12.00                    |
| 6   | 250.02      | 27.0 QP                 | 46.00          | -19.00      | 1.00 V             | 12                   | 14.00            | 13.00                    |
| 7   | 264.45      | 28.1 QP                 | 46.00          | -17.90      | 1.36 V             | 37                   | 14.00            | 14.00                    |
| 8   | 374.72      | 32.2 QP                 | 46.00          | -13.80      | 1.00 V             | 351                  | 16.00            | 16.20                    |
| 9   | 396.33      | 33.1 QP                 | 46.00          | -12.90      | 1.43 V             | 344                  | 16.10            | 17.00                    |
| 10  | 500.23      | 33.9 QP                 | 46.00          | -12.10      | 1.38 V             | 37                   | 14.60            | 19.30                    |
| 11  | 527.52      | 39.9 QP                 | 46.00          | -6.10       | 1.50 V             | 174                  | 20.30            | 19.60                    |
| 12  | 625.37      | 32.6 QP                 | 46.00          | -13.40      | 1.14 V             | 27                   | 10.90            | 21.70                    |

- REMARKS:**
1. Emission level(dBuV/m)=Raw Value(dBuV) + Correction Factor(dB)
  2. Correction Factor(dB/m) = Antenna Factor (dB/m) + Cable Factor (dB)
  3. The other emission levels were very low against the limit.
  4. Margin value = Emission level – Limit value.
  5. The limit value is defined as per 15.247.



## TEST RESULTS (A)- DSSS

|                                 |  |                          |                          |
|---------------------------------|--|--------------------------|--------------------------|
| <b>EUT</b>                      | Wireless Dual Band Enterprise Access Point | <b>MODEL</b>             | RBT3K-AG                 |
| <b>MODE</b>                     | Channel 1                                  | <b>FREQUENCY RANGE</b>   | 1000MHz~25000MHz         |
| <b>INPUT POWER (SYSTEM)</b>     | 120Vac, 60Hz                               | <b>DETECTOR FUNCTION</b> | Peak(PK)<br>Average (AV) |
| <b>ENVIRONMENTAL CONDITIONS</b> | 17deg. C, 68%RH,<br>974 hPa                | <b>TESTED BY</b>         | Eric Lee                 |

**ANTENNA POLARITY & TEST DISTANCE: HORIZONTAL AT 3 M**

| No. | Freq. (MHz) | Emission Level (dBuV/m) | Limit (dBuV/m) | Margin (dB) | Antenna Height (m) | Table Angle (Degree) | Raw Value (dBuV) | Correction Factor (dB/m) |
|-----|-------------|-------------------------|----------------|-------------|--------------------|----------------------|------------------|--------------------------|
| 1   | 2368.00     | 53.9 PK                 | 74.00          | -20.10      | 1.03 H             | 25                   | 24.20            | 29.70                    |
| 1   | 2368.00     | 41.9 AV                 | 54.00          | -12.10      | 1.03 H             | 25                   | 12.20            | 29.70                    |
| 2   | 2390.00     | 54.4 PK                 | 74.00          | -19.60      | 1.08 H             | 333                  | 24.60            | 29.80                    |
| 2   | 2390.00     | 45.5 AV                 | 54.00          | -8.50       | 1.08 H             | 333                  | 15.70            | 29.80                    |
| 3   | *2412.00    | 100.2 PK                |                |             | 1.56 H             | 132                  | 70.30            | 29.90                    |
| 3   | *2412.00    | 93.9 AV                 |                |             | 1.56 H             | 132                  | 64.00            | 29.90                    |
| 4   | 4824.00     | 39.6 PK                 | 74.00          | -34.40      | 1.02 H             | 25                   | 3.30             | 36.20                    |
| 4   | 4824.00     | 28.6 AV                 | 54.00          | -25.40      | 1.02 H             | 25                   | 3.30             | 36.20                    |
| 5   | 7236.00     | 45.9 PK                 | 74.00          | -28.10      | 1.45 H             | 21                   | 4.20             | 41.70                    |
| 5   | 7236.00     | 35.9 AV                 | 54.00          | -18.10      | 1.45 H             | 21                   | 4.20             | 41.70                    |
| 6   | 9648.00     | 46.4 PK                 | 74.00          | -27.60      | 1.44 H             | 101                  | 1.50             | 44.90                    |
| 6   | 9648.00     | 36.9 AV                 | 54.00          | -17.10      | 1.44 H             | 101                  | 1.50             | 44.90                    |

**ANTENNA POLARITY & TEST DISTANCE: VERTICAL AT 3 M**

| No.      | Freq. (MHz)    | Emission Level (dBuV/m) | Limit (dBuV/m) | Margin (dB)  | Antenna Height (m) | Table Angle (Degree) | Raw Value (dBuV) | Correction Factor (dB/m) |
|----------|----------------|-------------------------|----------------|--------------|--------------------|----------------------|------------------|--------------------------|
| 1        | 2368.00        | 59.9 PK                 | 74.00          | -14.10       | 1.14 V             | 304                  | 30.20            | 29.70                    |
| 1        | 2368.00        | 50.5 AV                 | 54.00          | -3.50        | 1.14 V             | 304                  | 20.80            | 29.70                    |
| 2        | 2390.00        | 61.2 PK                 | 74.00          | -12.80       | 1.40 V             | 25                   | 31.40            | 29.80                    |
| <b>2</b> | <b>2390.00</b> | <b>53.1 AV</b>          | <b>54.00</b>   | <b>-0.90</b> | <b>1.40 V</b>      | <b>25</b>            | <b>23.30</b>     | <b>29.80</b>             |
| 3        | *2412.00       | 107.9 PK                |                |              | 1.03 V             | 32                   | 78.00            | 29.90                    |
| 3        | *2412.00       | 100.8 AV                |                |              | 1.03 V             | 32                   | 70.90            | 29.90                    |
| 4        | 4824.00        | 42.9 PK                 | 74.00          | -31.10       | 1.02 V             | 65                   | 6.60             | 36.20                    |
| 4        | 4824.00        | 30.8 AV                 | 54.00          | -23.20       | 1.02 V             | 65                   | 6.60             | 36.20                    |
| 5        | 7236.00        | 49.3 PK                 | 74.00          | -24.70       | 1.87 V             | 54                   | 7.70             | 41.70                    |
| 5        | 7236.00        | 38.3 AV                 | 54.00          | -15.70       | 1.87 V             | 54                   | 7.70             | 41.70                    |
| 6        | 9648.00        | 51.1 PK                 | 74.00          | -22.90       | 1.64 V             | 319                  | 6.20             | 44.90                    |
| 6        | 9648.00        | 40.5 AV                 | 54.00          | -13.50       | 1.64 V             | 319                  | -4.40            | 36.20                    |

- NOTE:**
1. Emission level(dBuV/m)=Raw Value(dBuV) + Correction Factor(dB)
  2. Correction Factor(dB/m) = Antenna Factor (dB/m) + Cable Factor (dB)
  3. The other emission levels were very low against the limit.
  4. Margin value = Emission level - Limit value
  5. The limit value is defined as per 15.247
  6. " \* " : Fundamental frequency



|                                 |  |                          |                          |
|---------------------------------|--|--------------------------|--------------------------|
| <b>EUT</b>                      | Wireless Dual Band Enterprise Access Point | <b>MODEL</b>             | RBT3K-AG                 |
| <b>MODE</b>                     | Channel 6                                  | <b>FREQUENCY RANGE</b>   | 1000MHz~25000MHz         |
| <b>INPUT POWER (SYSTEM)</b>     | 120Vac, 60Hz                               | <b>DETECTOR FUNCTION</b> | Peak(PK)<br>Average (AV) |
| <b>ENVIRONMENTAL CONDITIONS</b> | 26deg. C, 67%RH,<br>974 hPa                | <b>TESTED BY</b>         | Eric Lee                 |

#### ANTENNA POLARITY & TEST DISTANCE: HORIZONTAL AT 3 M

| No. | Freq. (MHz) | Emission Level (dBuV/m) | Limit (dBuV/m) | Margin (dB) | Antenna Height (m) | Table Angle (Degree) | Raw Value (dBuV) | Correction Factor (dB/m) |
|-----|-------------|-------------------------|----------------|-------------|--------------------|----------------------|------------------|--------------------------|
| 1   | 2384.00     | 52.90 PK                | 74.00          | -21.10      | 1.05 H             | 42                   | 22.50            | 30.40                    |
| 1   | 2384.00     | 43.60 AV                | 54.00          | -10.40      | 1.05 H             | 42                   | 13.20            | 30.40                    |
| 2   | *2437.00    | 106.50 PK               |                |             | 1.69 H             | 98                   | 75.80            | 30.70                    |
| 2   | *2437.00    | 96.90 AV                |                |             | 1.69 H             | 98                   | 66.20            | 30.70                    |
| 3   | 2494.00     | 54.40 PK                | 74.00          | -19.60      | 1.59 H             | 353                  | 23.60            | 30.80                    |
| 3   | 2494.00     | 45.40 AV                | 54.00          | -8.60       | 1.59 H             | 353                  | 14.60            | 30.80                    |
| 4   | 4874.00     | 41.70 PK                | 74.00          | -32.30      | 1.70 H             | 215                  | 5.20             | 36.50                    |
| 5   | 7311.00     | 46.90 PK                | 74.00          | -27.10      | 1.02 H             | 29                   | 5.10             | 41.80                    |
| 6   | 9748.00     | 50.50 PK                | 74.00          | -23.50      | 1.63 H             | 261                  | 5.90             | 44.60                    |

#### ANTENNA POLARITY & TEST DISTANCE: VERTICAL AT 3 M

| No. | Freq. (MHz) | Emission Level (dBuV/m) | Limit (dBuV/m) | Margin (dB) | Antenna Height (m) | Table Angle (Degree) | Raw Value (dBuV) | Correction Factor (dB/m) |
|-----|-------------|-------------------------|----------------|-------------|--------------------|----------------------|------------------|--------------------------|
| 1   | 2384.00     | 59.20 PK                | 74.00          | -14.80      | 1.45 V             | 7                    | 28.80            | 30.40                    |
| 1   | 2384.00     | 51.00 AV                | 54.00          | -3.00       | 1.45 V             | 7                    | 20.60            | 30.40                    |
| 2   | *2437.00    | 111.00 PK               |                |             | 1.03 V             | 50                   | 80.30            | 30.70                    |
| 2   | *2437.00    | 102.90 AV               |                |             | 1.03 V             | 50                   | 72.20            | 30.70                    |
| 3   | 2494.00     | 61.20 PK                | 74.00          | -12.80      | 1.56 V             | 96                   | 30.40            | 30.80                    |
| 3   | 2494.00     | 52.90 AV                | 54.00          | -1.10       | 1.56 V             | 96                   | 22.10            | 30.80                    |
| 4   | 4874.00     | 45.40 PK                | 74.00          | -28.60      | 1.45 V             | 213                  | 8.90             | 36.50                    |
| 5   | 7311.00     | 50.00 PK                | 74.00          | -24.00      | 1.06 V             | 9                    | 8.20             | 41.80                    |
| 6   | 9748.00     | 53.70 PK                | 74.00          | -20.30      | 1.05 V             | 241                  | 9.10             | 44.60                    |
| 6   | 9748.00     | 42.50 AV                | 54.00          | -11.50      | 1.05 V             | 241                  | -2.10            | 44.60                    |

- NOTE:**
1. Emission level(dBuV/m)=Raw Value(dBuV) + Correction Factor(dB)
  2. Correction Factor(dB/m) = Antenna Factor (dB/m) + Cable Factor (dB)
  3. The other emission levels were very low against the limit.
  4. Margin value = Emission level - Limit value
  5. The limit value is defined as per 15.247
  6. “ \* “ : Fundamental frequency



|                                 |  |                          |                          |
|---------------------------------|--|--------------------------|--------------------------|
| <b>EUT</b>                      | Wireless Dual Band Enterprise Access Point | <b>MODEL</b>             | RBT3K-AG                 |
| <b>MODE</b>                     | Channel 11                                 | <b>FREQUENCY RANGE</b>   | 1000MHz~25000MHz         |
| <b>INPUT POWER (SYSTEM)</b>     | 120Vac, 60Hz                               | <b>DETECTOR FUNCTION</b> | Peak(PK)<br>Average (AV) |
| <b>ENVIRONMENTAL CONDITIONS</b> | 17deg. C, 68%RH,<br>974 hPa                | <b>TESTED BY</b>         | Eric Lee                 |

| ANTENNA POLARITY & TEST DISTANCE: HORIZONTAL AT 3M |             |                         |                |             |                    |                      |                  |                          |
|--|-------------|-------------------------|----------------|-------------|--------------------|----------------------|------------------|--------------------------|
| No.  | Freq. (MHz) | Emission Level (dBuV/m) | Limit (dBuV/m) | Margin (dB) | Antenna Height (m) | Table Angle (Degree) | Raw Value (dBuV) | Correction Factor (dB/m) |
| 1  | *2462.00    | 100.2 PK                |                |             | 1.04 H             | 25                   | 70.10            | 30.10                    |
| 1  | *2462.00    | 93.3 AV                 |                |             | 1.04 H             | 25                   | 63.20            | 30.10                    |
| 2  | 2483.50     | 54.4 PK                 | 74.00          | -19.60      | 1.42 H             | 25                   | 24.20            | 30.10                    |
| 2  | 2483.50     | 43.3 AV                 | 54.00          | -10.70      | 1.42 H             | 25                   | 13.20            | 30.10                    |
| 3  | 4924.00     | 38.8 PK                 | 74.00          | -35.20      | 1.45 H             | 247                  | 2.10             | 36.70                    |
| 3  | 4924.00     | 28.8 AV                 | 54.00          | -25.20      | 1.45 H             | 247                  | 2.10             | 36.70                    |
| 4  | 7386.00     | 45.2 PK                 | 74.00          | -28.80      | 1.45 H             | 247                  | 3.30             | 41.80                    |
| 4  | 7386.00     | 35.7 AV                 | 54.00          | -18.30      | 1.45 H             | 247                  | 3.30             | 41.80                    |
| 5  | 9848.00     | 49.4 PK                 | 74.00          | -24.60      | 1.52 H             | 324                  | 5.00             | 44.40                    |
| 5  | 9848.00     | 37.8 AV                 | 54.00          | -16.20      | 1.52 H             | 324                  | 5.00             | 44.40                    |

| ANTENNA POLARITY & TEST DISTANCE: VERTICAL AT 3M |             |                         |                |             |                    |                      |                  |                          |
|--|-------------|-------------------------|----------------|-------------|--------------------|----------------------|------------------|--------------------------|
| No.  | Freq. (MHz) | Emission Level (dBuV/m) | Limit (dBuV/m) | Margin (dB) | Antenna Height (m) | Table Angle (Degree) | Raw Value (dBuV) | Correction Factor (dB/m) |
| 1  | *2462.00    | 107.2 PK                |                |             | 1.05 V             | 326                  | 77.10            | 30.10                    |
| 1  | *2462.00    | 101.0 AV                |                |             | 1.05 V             | 326                  | 70.90            | 30.10                    |
| 2  | 2483.50     | 60.3 PK                 | 74.00          | -13.70      | 1.08 V             | 208                  | 30.20            | 30.10                    |
| 2  | 2483.50     | 53.0 AV                 | 54.00          | -1.00       | 1.08 V             | 208                  | 22.90            | 30.10                    |
| 3  | 4924.00     | 43.8 PK                 | 74.00          | -30.20      | 1.25 V             | 352                  | 7.10             | 36.70                    |
| 3  | 4924.00     | 33.0 AV                 | 54.00          | -21.00      | 1.25 V             | 352                  | 7.10             | 36.70                    |
| 4  | 7386.00     | 48.2 PK                 | 74.00          | -25.80      | 1.40 V             | 141                  | 6.40             | 41.80                    |
| 4  | 7386.00     | 38.3 AV                 | 54.00          | -15.70      | 1.40 V             | 141                  | 6.40             | 41.80                    |
| 5  | 9848.00     | 50.4 PK                 | 74.00          | -23.60      | 1.46 V             | 352                  | 6.00             | 44.40                    |
| 5  | 9848.00     | 39.4 AV                 | 54.00          | -14.60      | 1.46 V             | 352                  | 6.00             | 44.40                    |

- NOTE:**
1. Emission level(dBuV/m)=Raw Value(dBuV) + Correction Factor(dB)
  2. Correction Factor(dB/m) = Antenna Factor (dB/m) + Cable Factor (dB)
  3. The other emission levels were very low against the limit.
  4. Margin value = Emission level - Limit value
  5. The limit value is defined as per 15.247
  6. “ \* “ : Fundamental frequency



## TEST RESULTS (A)- OFDM

|                                 |  |                          |                          |
|---------------------------------|--|--------------------------|--------------------------|
| <b>EUT</b>                      | Wireless Dual Band Enterprise Access Point | <b>MODEL</b>             | RBT3K-AG                 |
| <b>MODE</b>                     | Channel 1                                  | <b>FREQUENCY RANGE</b>   | 1000MHz~25000MHz         |
| <b>INPUT POWER (SYSTEM)</b>     | 120Vac, 60Hz                               | <b>DETECTOR FUNCTION</b> | Peak(PK)<br>Average (AV) |
| <b>ENVIRONMENTAL CONDITIONS</b> | 28deg. C, 56%RH,<br>974 hPa                | <b>TESTED BY</b>         | Eric Lee                 |

**ANTENNA POLARITY & TEST DISTANCE: HORIZONTAL AT 3 M**

| No. | Freq. (MHz) | Emission Level (dBuV/m) | Limit (dBuV/m) | Margin (dB) | Antenna Height (m) | Table Angle (Degree) | Raw Value (dBuV) | Correction Factor (dB/m) |
|-----|-------------|-------------------------|----------------|-------------|--------------------|----------------------|------------------|--------------------------|
| 1   | 2368.00     | 51.3 PK                 | 74.00          | -22.70      | 1.23 H             | 65                   | 21.60            | 29.70                    |
| 1   | 2368.00     | 41.3 AV                 | 54.00          | -12.70      | 1.23 H             | 65                   | 11.60            | 29.70                    |
| 2   | 2390.00     | 54.4 PK                 | 74.00          | -19.60      | 1.54 H             | 8                    | 24.60            | 29.80                    |
| 2   | 2390.00     | 46.0 AV                 | 54.00          | -8.00       | 1.54 H             | 8                    | 16.20            | 29.80                    |
| 3   | *2412.00    | 96.0 PK                 |                |             | 1.03 H             | 140                  | 66.10            | 29.90                    |
| 3   | *2412.00    | 86.8 AV                 |                |             | 1.03 H             | 140                  | 56.90            | 29.90                    |
| 4   | 4824.00     | 37.5 PK                 | 74.00          | -36.50      | 1.01 H             | 21                   | 1.30             | 36.20                    |
| 4   | 4824.00     | 27.3 AV                 | 54.00          | -26.70      | 1.01 H             | 21                   | 1.30             | 36.20                    |
| 5   | 7236.00     | 42.8 PK                 | 74.00          | -31.20      | 1.47 H             | 54                   | 1.20             | 41.70                    |
| 5   | 7236.00     | 34.3 AV                 | 54.00          | -19.70      | 1.47 H             | 54                   | 1.20             | 41.70                    |
| 6   | 9648.00     | 46.5 PK                 | 74.00          | -27.50      | 1.03 H             | 352                  | 1.60             | 44.90                    |
| 6   | 9648.00     | 36.5 AV                 | 54.00          | -17.50      | 1.03 H             | 352                  | 1.60             | 44.90                    |

**ANTENNA POLARITY & TEST DISTANCE: VERTICAL AT 3 M**

| No. | Freq. (MHz) | Emission Level (dBuV/m) | Limit (dBuV/m) | Margin (dB) | Antenna Height (m) | Table Angle (Degree) | Raw Value (dBuV) | Correction Factor (dB/m) |
|-----|-------------|-------------------------|----------------|-------------|--------------------|----------------------|------------------|--------------------------|
| 1   | 2368.00     | 58.1 PK                 | 74.00          | -15.90      | 1.23 V             | 41                   | 28.40            | 29.70                    |
| 1   | 2368.00     | 49.3 AV                 | 54.00          | -4.70       | 1.23 V             | 41                   | 19.60            | 29.70                    |
| 2   | 2390.00     | 61.9 PK                 | 74.00          | -12.10      | 1.25 V             | 24                   | 32.10            | 29.80                    |
| 2   | 2390.00     | 52.1 AV                 | 54.00          | -1.90       | 1.25 V             | 24                   | 22.30            | 29.80                    |
| 3   | *2412.00    | 102.4 PK                |                |             | 1.05 V             | 22                   | 72.50            | 29.90                    |
| 3   | *2412.00    | 93.8 AV                 |                |             | 1.05 V             | 22                   | 63.90            | 29.90                    |
| 4   | 4824.00     | 41.7 PK                 | 74.00          | -32.30      | 1.00 V             | 21                   | 5.50             | 36.20                    |
| 4   | 4824.00     | 30.4 AV                 | 54.00          | -23.60      | 1.00 V             | 21                   | 5.50             | 36.20                    |
| 5   | 7236.00     | 48.2 PK                 | 74.00          | -25.80      | 1.01 V             | 21                   | 6.50             | 41.70                    |
| 5   | 7236.00     | 36.6 AV                 | 54.00          | -17.40      | 1.01 V             | 21                   | 6.50             | 41.70                    |
| 6   | 9648.00     | 49.7 PK                 | 74.00          | -24.30      | 1.09 V             | 0                    | 4.80             | 44.90                    |
| 6   | 9648.00     | 38.4 AV                 | 54.00          | -15.60      | 1.09 V             | 0                    | 4.80             | 44.90                    |

- NOTE:**
1. Emission level(dBuV/m)=Raw Value(dBuV) + Correction Factor(dB)
  2. Correction Factor(dB/m) = Antenna Factor (dB/m) + Cable Factor (dB)
  3. The other emission levels were very low against the limit.
  4. Margin value = Emission level - Limit value
  5. The limit value is defined as per 15.247
  6. “ \* ” : Fundamental frequency





|                                 |  |                          |                          |
|---------------------------------|--|--------------------------|--------------------------|
| <b>EUT</b>                      | Wireless Dual Band Enterprise Access Point | <b>MODEL</b>             | RBT3K-AG                 |
| <b>MODE</b>                     | Channel 6                                  | <b>FREQUENCY RANGE</b>   | 1000MHz~25000MHz         |
| <b>INPUT POWER (SYSTEM)</b>     | 120Vac, 60Hz                               | <b>DETECTOR FUNCTION</b> | Peak(PK)<br>Average (AV) |
| <b>ENVIRONMENTAL CONDITIONS</b> | 26deg. C, 61%RH,<br>974 hPa                | <b>TESTED BY</b>         | Eric Lee                 |

#### ANTENNA POLARITY & TEST DISTANCE: HORIZONTAL AT 3 M

| No. | Freq. (MHz) | Emission Level (dBuV/m) | Limit (dBuV/m) | Margin (dB) | Antenna Height (m) | Table Angle (Degree) | Raw Value (dBuV) | Correction Factor (dB/m) |
|-----|-------------|-------------------------|----------------|-------------|--------------------|----------------------|------------------|--------------------------|
| 1   | 2384.00     | 51.00 PK                | 74.00          | -23.00      | 1.75 H             | 65                   | 20.60            | 30.40                    |
| 1   | 2384.00     | 44.20 AV                | 54.00          | -9.80       | 1.75 H             | 65                   | 13.80            | 30.40                    |
| 2   | 2390.00     | 52.40 PK                | 74.00          | -21.60      | 1.26 H             | 256                  | 22.00            | 30.40                    |
| 2   | 2390.00     | 41.60 AV                | 54.00          | -12.40      | 1.26 H             | 256                  | 11.20            | 30.40                    |
| 3   | *2437.00    | 102.00 PK               |                |             | 1.54 H             | 26                   | 71.30            | 30.70                    |
| 3   | *2437.00    | 92.70 AV                |                |             | 1.54 H             | 26                   | 62.00            | 30.70                    |
| 4   | 2483.50     | 52.10 PK                | 74.00          | -21.90      | 1.02 H             | 78                   | 21.20            | 31.00                    |
| 4   | 2483.50     | 43.20 AV                | 54.00          | -10.80      | 1.02 H             | 78                   | 12.20            | 31.00                    |
| 5   | 4874.00     | 42.60 PK                | 74.00          | -31.40      | 1.45 H             | 54                   | 6.10             | 36.50                    |
| 6   | 7311.00     | 47.10 PK                | 74.00          | -26.90      | 1.54 H             | 226                  | 5.40             | 41.80                    |
| 7   | 9748.00     | 52.60 PK                | 74.00          | -21.40      | 1.06 H             | 98                   | 8.00             | 44.60                    |
| 7   | 9748.00     | 41.00 AV                | 54.00          | -13.00      | 1.06 H             | 98                   | -3.60            | 44.60                    |

#### ANTENNA POLARITY & TEST DISTANCE: VERTICAL AT 3 M

| No. | Freq. (MHz) | Emission Level (dBuV/m) | Limit (dBuV/m) | Margin (dB) | Antenna Height (m) | Table Angle (Degree) | Raw Value (dBuV) | Correction Factor (dB/m) |
|-----|-------------|-------------------------|----------------|-------------|--------------------|----------------------|------------------|--------------------------|
| 1   | 2384.00     | 62.10 PK                | 74.00          | -11.90      | 1.10 V             | 64                   | 31.70            | 30.40                    |
| 1   | 2384.00     | 53.00 AV                | 54.00          | -1.00       | 1.10 V             | 64                   | 22.60            | 30.40                    |
| 2   | 2390.00     | 59.60 PK                | 74.00          | -14.40      | 1.10 V             | 23                   | 29.10            | 30.40                    |
| 2   | 2390.00     | 49.90 AV                | 54.00          | -4.10       | 1.10 V             | 23                   | 19.40            | 30.40                    |
| 3   | *2437.00    | 108.60 PK               |                |             | 1.01 V             | 49                   | 78.00            | 30.70                    |
| 3   | *2437.00    | 99.90 AV                |                |             | 1.01 V             | 49                   | 69.20            | 30.70                    |
| 4   | 2483.50     | 59.80 PK                | 74.00          | -14.20      | 1.12 V             | 16                   | 28.90            | 31.00                    |
| 4   | 2483.50     | 50.60 AV                | 54.00          | -3.40       | 1.12 V             | 16                   | 19.60            | 31.00                    |
| 5   | 4874.00     | 46.80 PK                | 74.00          | -27.20      | 1.54 V             | 24                   | 10.30            | 36.50                    |
| 6   | 7311.00     | 50.90 PK                | 74.00          | -23.10      | 1.50 V             | 5                    | 9.10             | 41.80                    |
| 7   | 9748.00     | 54.20 PK                | 74.00          | -19.80      | 1.42 V             | 26                   | 9.60             | 44.60                    |
| 7   | 9748.00     | 42.70 AV                | 54.00          | -11.30      | 1.42 V             | 26                   | -1.90            | 44.60                    |

- NOTE:**
1. Emission level(dBuV/m)=Raw Value(dBuV) + Correction Factor(dB)
  2. Correction Factor(dB/m) = Antenna Factor (dB/m) + Cable Factor (dB)
  3. The other emission levels were very low against the limit.
  4. Margin value = Emission level - Limit value
  5. The limit value is defined as per 15.247
  6. " \* " : Fundamental frequency



|                                 |  |                          |                          |
|---------------------------------|--|--------------------------|--------------------------|
| <b>EUT</b>                      | Wireless Dual Band Enterprise Access Point | <b>MODEL</b>             | RBT3K-AG                 |
| <b>MODE</b>                     | Channel 11                                 | <b>FREQUENCY RANGE</b>   | 1000MHz~25000MHz         |
| <b>INPUT POWER (SYSTEM)</b>     | 120Vac, 60Hz                               | <b>DETECTOR FUNCTION</b> | Peak(PK)<br>Average (AV) |
| <b>ENVIRONMENTAL CONDITIONS</b> | 28deg. C, 56%RH,<br>974 hPa                | <b>TESTED BY</b>         | Eric Lee                 |

#### ANTENNA POLARITY & TEST DISTANCE: HORIZONTAL AT 3M

| No. | Freq. (MHz) | Emission Level (dBuV/m) | Limit (dBuV/m) | Margin (dB) | Antenna Height (m) | Table Angle (Degree) | Raw Value (dBuV) | Correction Factor (dB/m) |
|-----|-------------|-------------------------|----------------|-------------|--------------------|----------------------|------------------|--------------------------|
| 1   | *2462.00    | 93.5 PK                 |                |             | 1.08 H             | 352                  | 63.50            | 30.10                    |
| 1   | *2462.00    | 83.3 AV                 |                |             | 1.08 H             | 352                  | 53.30            | 30.10                    |
| 2   | 2483.50     | 54.3 PK                 | 74.00          | -19.70      | 1.02 H             | 35                   | 24.20            | 30.10                    |
| 2   | 2483.50     | 45.3 AV                 | 54.00          | -8.70       | 1.02 H             | 35                   | 15.20            | 30.10                    |
| 3   | 4924.00     | 38.7 PK                 | 74.00          | -35.30      | 1.02 H             | 24                   | 2.00             | 36.70                    |
| 3   | 4924.00     | 29.2 AV                 | 54.00          | -24.80      | 1.02 H             | 24                   | 2.00             | 36.70                    |
| 4   | 7386.00     | 44.6 PK                 | 74.00          | -29.40      | 1.08 H             | 333                  | 2.70             | 41.80                    |
| 4   | 7386.00     | 33.6 AV                 | 54.00          | -20.40      | 1.08 H             | 333                  | 2.70             | 41.80                    |
| 5   | 9848.00     | 48.1 PK                 | 74.00          | -25.90      | 1.07 H             | 131                  | 3.70             | 44.40                    |
| 5   | 9848.00     | 37.2 AV                 | 54.00          | -16.80      | 1.07 H             | 131                  | 3.70             | 44.40                    |

#### ANTENNA POLARITY & TEST DISTANCE: VERTICAL AT 3M

| No. | Freq. (MHz) | Emission Level (dBuV/m) | Limit (dBuV/m) | Margin (dB) | Antenna Height (m) | Table Angle (Degree) | Raw Value (dBuV) | Correction Factor (dB/m) |
|-----|-------------|-------------------------|----------------|-------------|--------------------|----------------------|------------------|--------------------------|
| 1   | *2462.00    | 102.1 PK                |                |             | 1.11 V             | 312                  | 72.00            | 30.10                    |
| 1   | *2462.00    | 94.1 AV                 |                |             | 1.11 V             | 312                  | 64.00            | 30.10                    |
| 2   | 2483.50     | 61.2 PK                 | 74.00          | -12.80      | 1.40 V             | 269                  | 31.10            | 30.10                    |
| 2   | 2483.50     | 52.9 AV                 | 54.00          | -1.10       | 1.40 V             | 269                  | 22.80            | 30.10                    |
| 3   | 4924.00     | 42.8 PK                 | 74.00          | -31.20      | 1.23 V             | 35                   | 6.10             | 36.70                    |
| 3   | 4924.00     | 32.8 AV                 | 54.00          | -21.20      | 1.23 V             | 35                   | 6.10             | 36.70                    |
| 4   | 7386.00     | 49.2 PK                 | 74.00          | -24.80      | 1.24 V             | 96                   | 7.30             | 41.80                    |
| 4   | 7386.00     | 38.5 AV                 | 54.00          | -15.50      | 1.24 V             | 96                   | 7.30             | 41.80                    |
| 5   | 9848.00     | 49.3 PK                 | 74.00          | -24.70      | 1.05 V             | 301                  | 5.00             | 44.40                    |
| 5   | 9848.00     | 40.8 AV                 | 54.00          | -13.20      | 1.05 V             | 301                  | 5.00             | 44.40                    |

- NOTE:**
1. Emission level(dBuV/m)=Raw Value(dBuV) + Correction Factor(dB)
  2. Correction Factor(dB/m) = Antenna Factor (dB/m) + Cable Factor (dB)
  3. The other emission levels were very low against the limit.
  4. Margin value = Emission level - Limit value
  5. The limit value is defined as per 15.247
  6. " \* " : Fundamental frequency



### 4.3 6dB BANDWIDTH MEASUREMENT

#### 4.3.1 LIMITS OF 6dB BANDWIDTH MEASUREMENT

The minimum of 6dB Bandwidth Measurement is 0.5 MHz.

#### 4.3.2 TEST INSTRUMENTS

| Description & Manufacturer | Model No. | Serial No.   | Calibrated Until |
|----------------------------|-----------|--------------|------------------|
| R&S SPECTRUM ANALYZER      | FSP       | 1093.4495.30 | Dec. 19, 2003    |

**NOTE:**

- 1.The measurement uncertainty is less than +/- 2.6dB, which is calculated as per the NAMAS document NIS81.
- 2.The calibration interval of the above test instruments is 12 months and the calibrations are traceable to NML/ROC and NIST/USA.

### 4.3.3 TEST PROCEDURE

The transmitter output was connected to the spectrum analyzer through an attenuator. The bandwidth of the fundamental frequency was measured by spectrum analyzer with 100kHz RBW and 100kHz VBW. The 6dB bandwidth is defined as the total spectrum the power of which is higher than peak power minus 6 dB.

### 4.3.4 DEVIATION FROM TEST STANDARD

No deviation

### 4.3.5 TEST SETUP

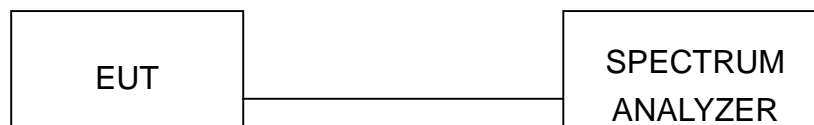

### 4.3.6 EUT OPERATING CONDITIONS

The software provided by client to enable the EUT under transmission condition continuously at lowest, middle and highest channel frequencies individually.



## 4.3.7 TEST RESULTS (A)

|                             |  |                                 |                          |
|-----------------------------|--|---------------------------------|--------------------------|
| <b>EUT</b>                  | Wireless Dual Band Enterprise Access Point | <b>MODEL</b>                    | RBT3K-AG                 |
| <b>INPUT POWER (SYSTEM)</b> | 120Vac, 60Hz                               | <b>ENVIRONMENTAL CONDITIONS</b> | 21deg. C, 58%RH, 974 hPa |
| <b>TESTED BY</b>            | Eric Lee                                   |                                 |                          |

| <b>CHANNEL</b> | <b>CHANNEL FREQUENCY (MHz)</b> | <b>6dB BANDWIDTH (MHz)</b> | <b>MINIMUM LIMIT (MHz)</b> | <b>PASS/FAIL</b> |
|----------------|--------------------------------|----------------------------|----------------------------|------------------|
| 1              | 2412                           | 11.96                      | 0.5                        | PASS             |
| 6              | 2437                           | 11.32                      | 0.5                        | PASS             |
| 11             | 2462                           | 11.84                      | 0.5                        | PASS             |



CH1

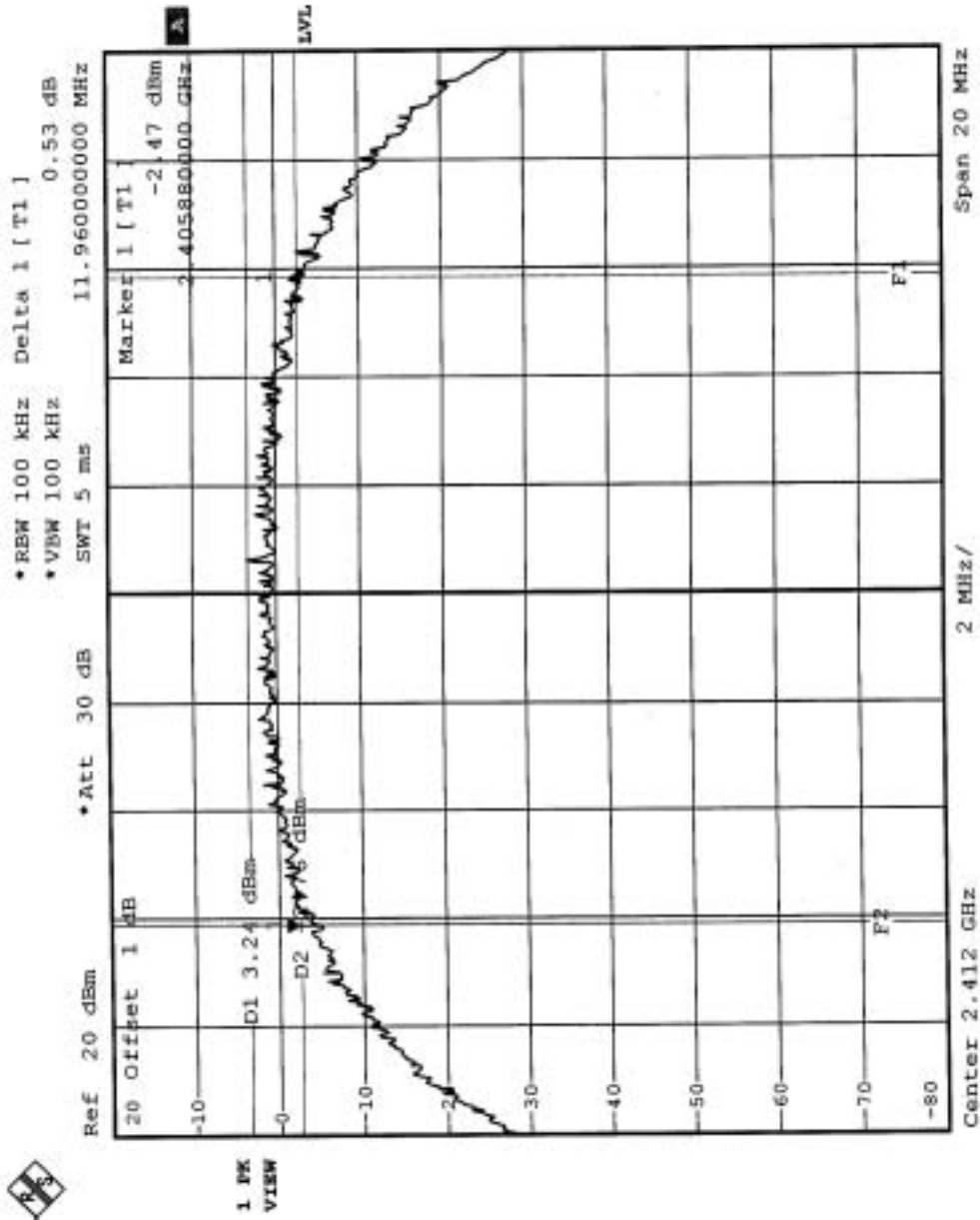



CH6

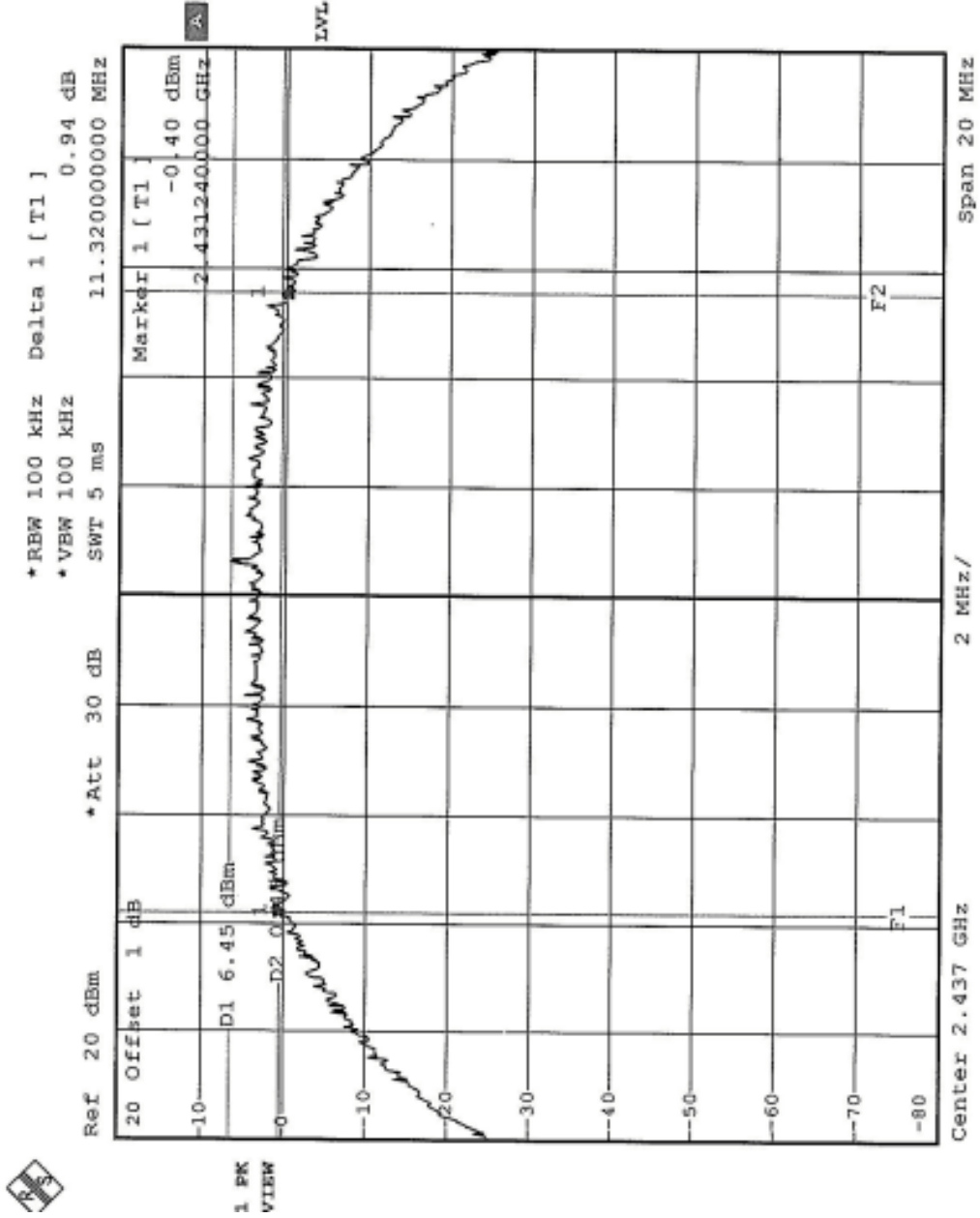



CH11

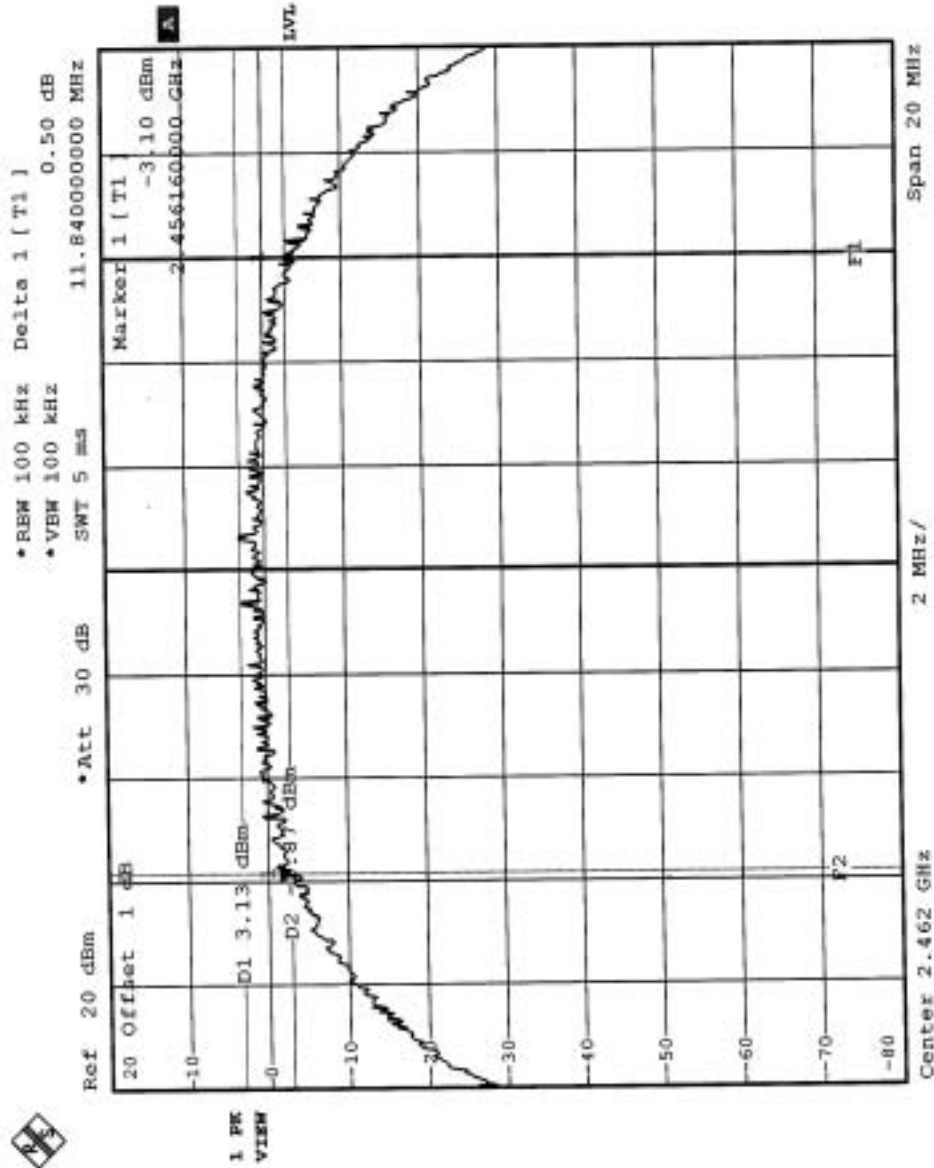





## 4.3.8 TEST RESULTS (B)

|                                 |   |                                     |                             |
|---------------------------------|---|-------------------------------------|-----------------------------|
| <b>EUT</b>                      | Wireless Dual Band<br>Enterprise Access Point | <b>MODEL</b>                        | RBT3K-AG                    |
| <b>INPUT POWER<br/>(SYSTEM)</b> | 120Vac, 60Hz                                  | <b>ENVIRONMENTAL<br/>CONDITIONS</b> | 21deg. C, 58%RH,<br>974 hPa |
| <b>TESTED BY</b>                | Eric Lee                                      |                                     |                             |

| <b>CHANNEL</b> | <b>CHANNEL<br/>FREQUENCY<br/>(MHz)</b> | <b>6dB BANDWIDTH<br/>(MHz)</b> | <b>MINIMUM<br/>LIMIT<br/>(MHz)</b> | <b>PASS/FAIL</b> |
|----------------|--|--------------------------------|------------------------------------|------------------|
| 1              | 2412                                   | 16.6                           | 0.5                                | PASS             |
| 6              | 2437                                   | 16.65                          | 0.5                                | PASS             |
| 11             | 2462                                   | 16.6                           | 0.5                                | PASS             |



CH1

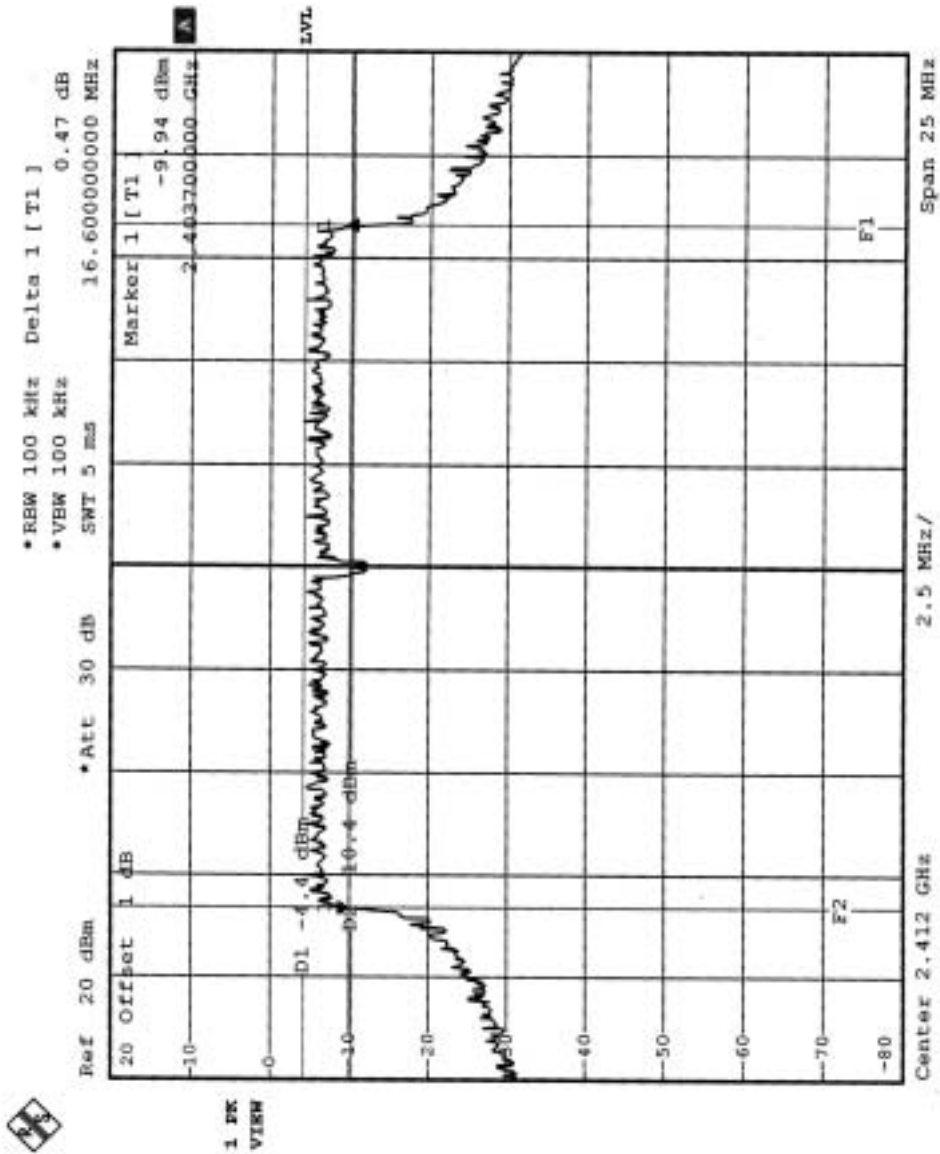



CH6

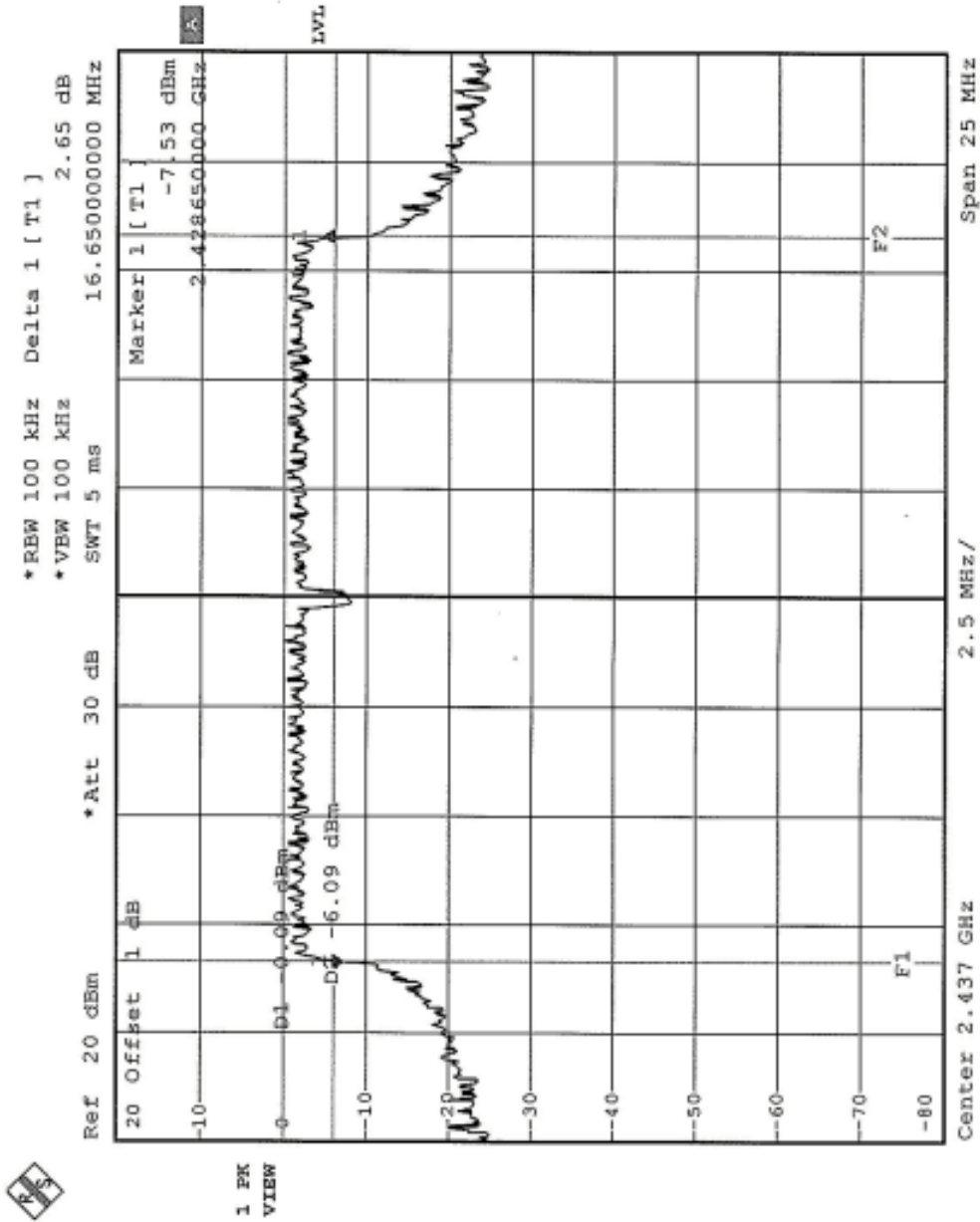



CH11

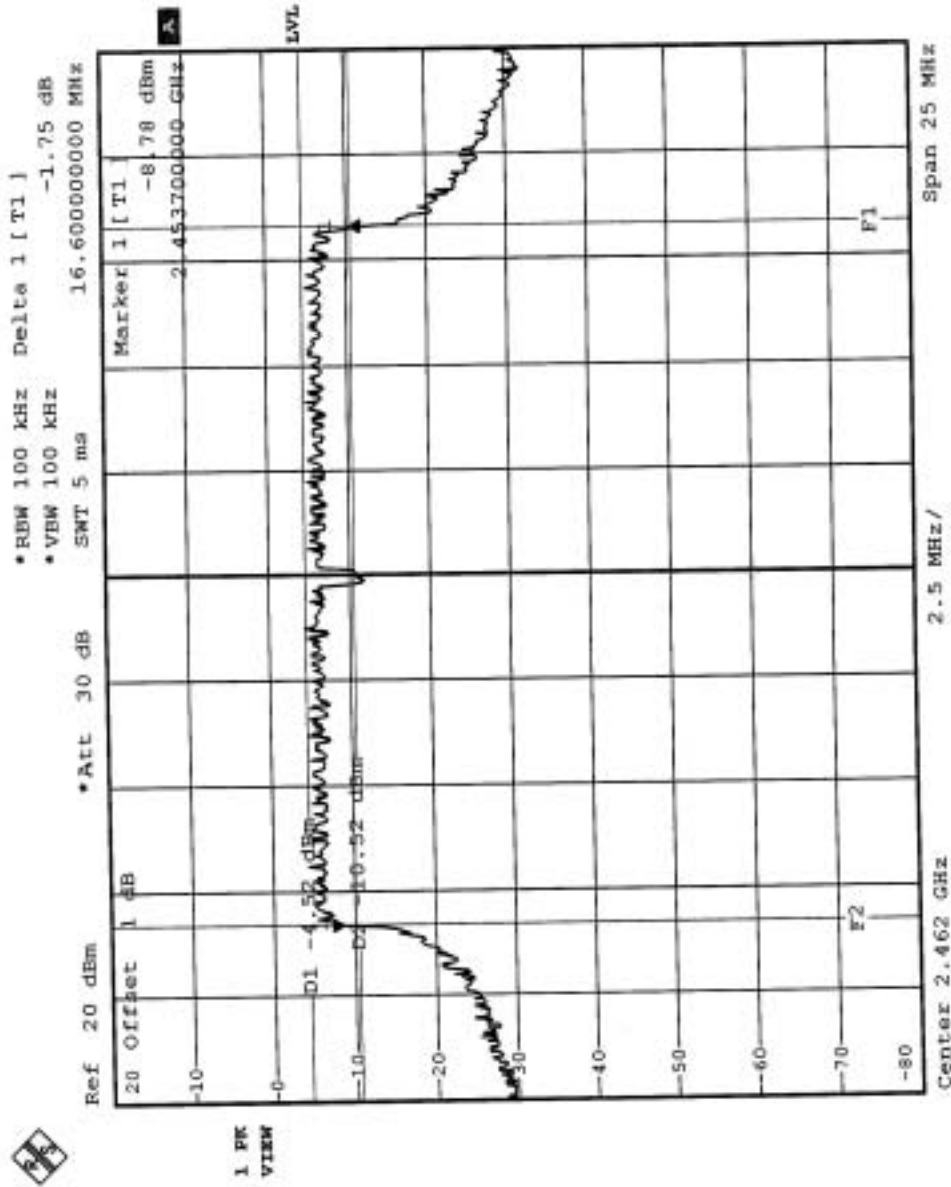



#### 4.4 MAXIMUM PEAK OUTPUT POWER

##### 4.4.1 LIMITS OF MAXIMUM PEAK OUTPUT POWER MEASUREMENT

The Maximum Peak Output Power Measurement is 30dBm.

##### 4.4.2 INSTRUMENTS

| Description & Manufacturer | Model No. | Serial No. | Calibrated Until |
|----------------------------|-----------|------------|------------------|
| R&S SPECTRUM ANALYZER      | FSP30     | 100019     | Dec. 19, 2003    |
| R&S SIGNAL GENERATOR       | SMP04     | 100011     | May 28, 2004     |
| TEKTRONIX OSCILLOSCOPE     | TDS 220   | B048470    | Mar. 05, 2004    |
| NARDA DETECTOR             | 4503A     | FSCM99899  | NA               |

**NOTE:**

The calibration interval of the above test instruments is 12 months and the calibrations are traceable to NML/ROC and NIST/USA.



#### 4.4.3 TEST PROCEDURES

1. A detector was used on the output port of the EUT. An oscilloscope was used to read the peak response of the detector.
2. Replaced the EUT by the signal generator. The center frequency of the S.G was adjusted to the center frequency of the measured channel.
3. Adjusted the power to have the same peak reading on oscilloscope. Record the power level.

#### 4.4.4 TEST SETUP

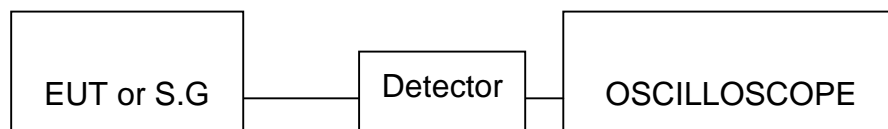

#### 4.4.5 EUT OPERATING CONDITIONS

Same as Item 4.3.6



4.4.6 TEST RESULTS (A)

|                             |  |                                 |                          |
|-----------------------------|--|---------------------------------|--------------------------|
| <b>EUT</b>                  | Wireless Dual Band Enterprise Access Point | <b>MODEL</b>                    | RBT3K-AG                 |
| <b>INPUT POWER (SYSTEM)</b> | 120Vac, 60Hz                               | <b>ENVIRONMENTAL CONDITIONS</b> | 19deg. C, 64%RH, 974 hPa |
| <b>TESTED BY</b>            | Eric Lee                                   |                                 |                          |

| CHANNEL | CHANNEL FREQUENCY (MHz) | PEAK POWER OUTPUT (dBm) | PEAK POWER LIMIT (dBm) | PASS/FAIL |
|---------|-------------------------|-------------------------|------------------------|-----------|
| 1       | 2412                    | 15.63                   | 30                     | PASS      |
| 6       | 2437                    | 18.3                    | 30                     | PASS      |
| 11      | 2462                    | 15.29                   | 30                     | PASS      |

4.4.7 TEST RESULTS (B)

|                             |  |                                 |                          |
|-----------------------------|--|---------------------------------|--------------------------|
| <b>EUT</b>                  | Wireless Dual Band Enterprise Access Point | <b>MODEL</b>                    | RBT3K-AG                 |
| <b>INPUT POWER (SYSTEM)</b> | 120Vac, 60Hz                               | <b>ENVIRONMENTAL CONDITIONS</b> | 19deg. C, 64%RH, 974 hPa |
| <b>TESTED BY</b>            | Eric Lee                                   |                                 |                          |

| CHANNEL | CHANNEL FREQUENCY (MHz) | PEAK POWER OUTPUT (dBm) | PEAK POWER LIMIT (dBm) | PASS/FAIL |
|---------|-------------------------|-------------------------|------------------------|-----------|
| 1       | 2412                    | 16.23                   | 30                     | PASS      |
| 6       | 2437                    | 18.2                    | 30                     | PASS      |
| 11      | 2462                    | 16.01                   | 30                     | PASS      |



## 4.5 POWER SPECTRAL DENSITY MEASUREMENT

### 4.5.1 LIMITS OF POWER SPECTRAL DENSITY MEASUREMENT

The Maximum of Power Spectral Density Measurement is 8dBm.

### 4.5.2 TEST INSTRUMENTS

| Description & Manufacturer | Model No. | Serial No.   | Calibrated Until |
|----------------------------|-----------|--------------|------------------|
| R&S SPECTRUM ANALYZER      | FSP       | 1093.4495.30 | Dec. 19, 2003    |

**NOTE:**

- 1.The measurement uncertainty is less than +/- 2.6dB, which is calculated as per the NAMAS document NIS81.
- 2.The calibration interval of the above test instruments is 12 months and the calibrations are traceable to NML/ROC and NIST/USA.



#### 4.5.3 TEST PROCEDURE

The transmitter output was connected to the spectrum analyzer through an attenuator, the bandwidth of the fundamental frequency was measured with the spectrum analyzer using 3 kHz RBW and 30 kHz VBW, set sweep time = span/3 kHz. The power spectral density was measured and recorded.

The sweep time is allowed to be longer than span/3 kHz for a full response of the mixer in the spectrum analyzer.

#### 4.5.4 DEVIATION FROM TEST STANDARD

No deviation

#### 4.5.5 TEST SETUP

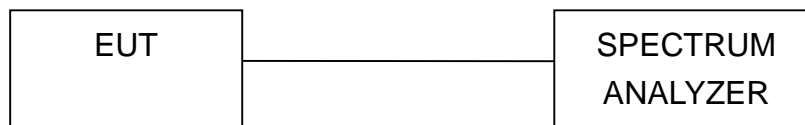

#### 4.5.6 EUT OPERATING CONDITION

Same as Item 4.3.6



## 4.5.7 TEST RESULTS(A)

|                                 |   |                                     |                            |
|---------------------------------|---|-------------------------------------|----------------------------|
| <b>EUT</b>                      | Wireless Dual Band<br>Enterprise Access Point | <b>MODEL</b>                        | RBT3K-AG                   |
| <b>INPUT POWER<br/>(SYSTEM)</b> | 120Vac, 60Hz                                  | <b>ENVIRONMENTAL<br/>CONDITIONS</b> | 21deg. C, 58RH,<br>974 hPa |
| <b>TESTED BY</b>                | Eric Lee                                      |                                     |                            |

| <b>CHANNEL<br/>NUMBER</b> | <b>CHANNEL<br/>FREQUENCY<br/>(MHz )</b> | <b>RF POWER LEVEL<br/>IN 3 kHz BW<br/>(dBm)</b> | <b>MAXIMUM<br/>LIMIT<br/>(dBm)</b> | <b>PASS/FAIL</b> |
|---------------------------|---|---|------------------------------------|------------------|
| 1                         | 2412                                    | -11.01  | 8                                  | PASS             |
| 6                         | 2437                                    | -8.66   | 8                                  | PASS             |
| 11                        | 2462                                    | -11.28  | 8                                  | PASS             |



CH1

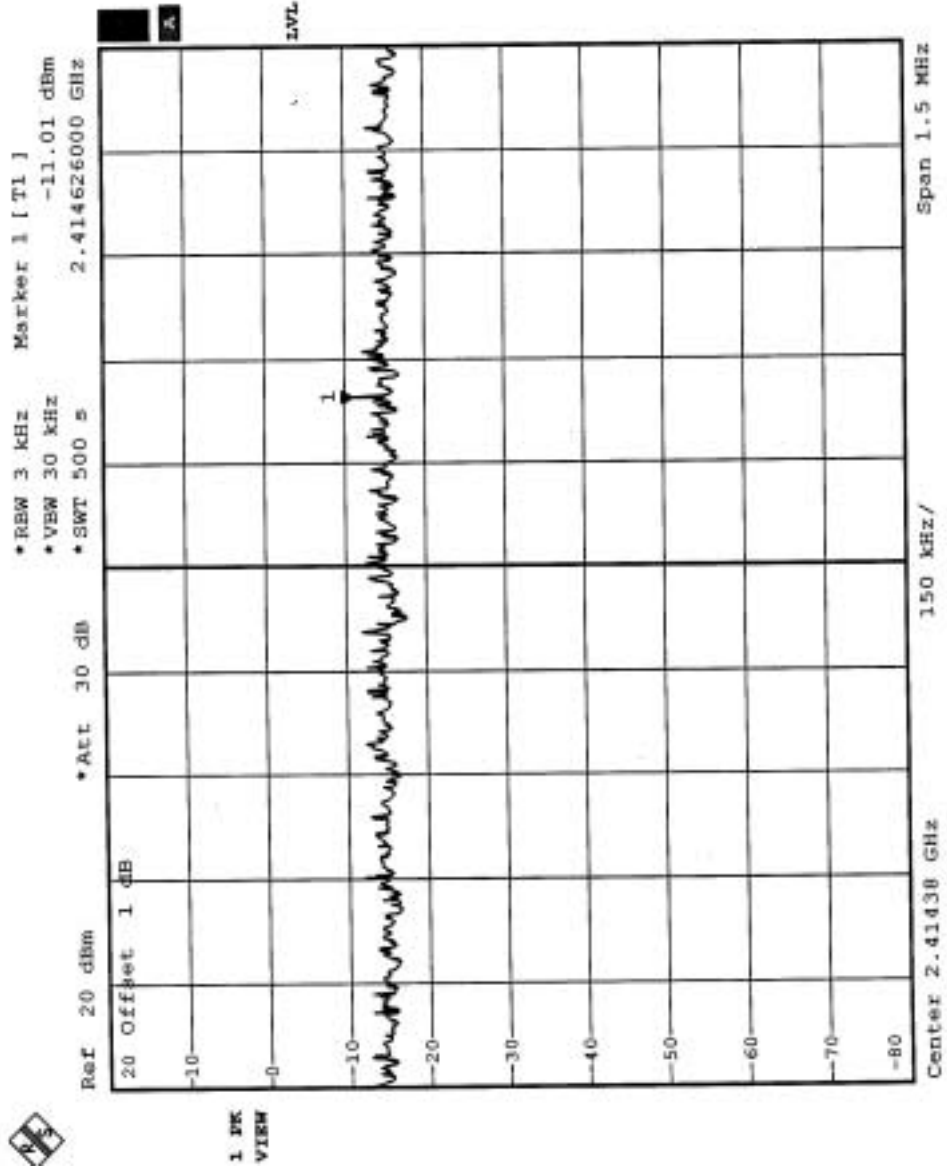



CH6

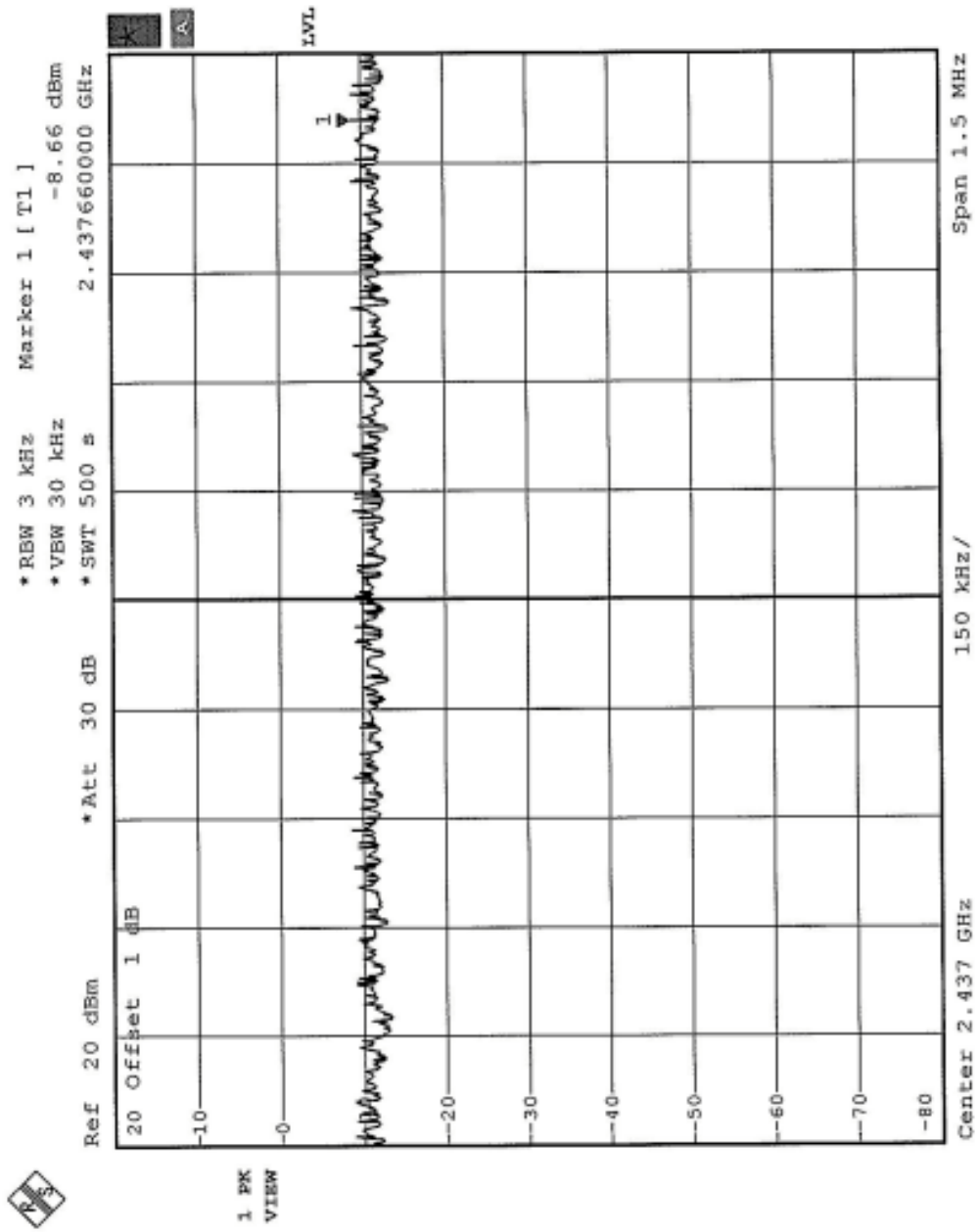



CH11

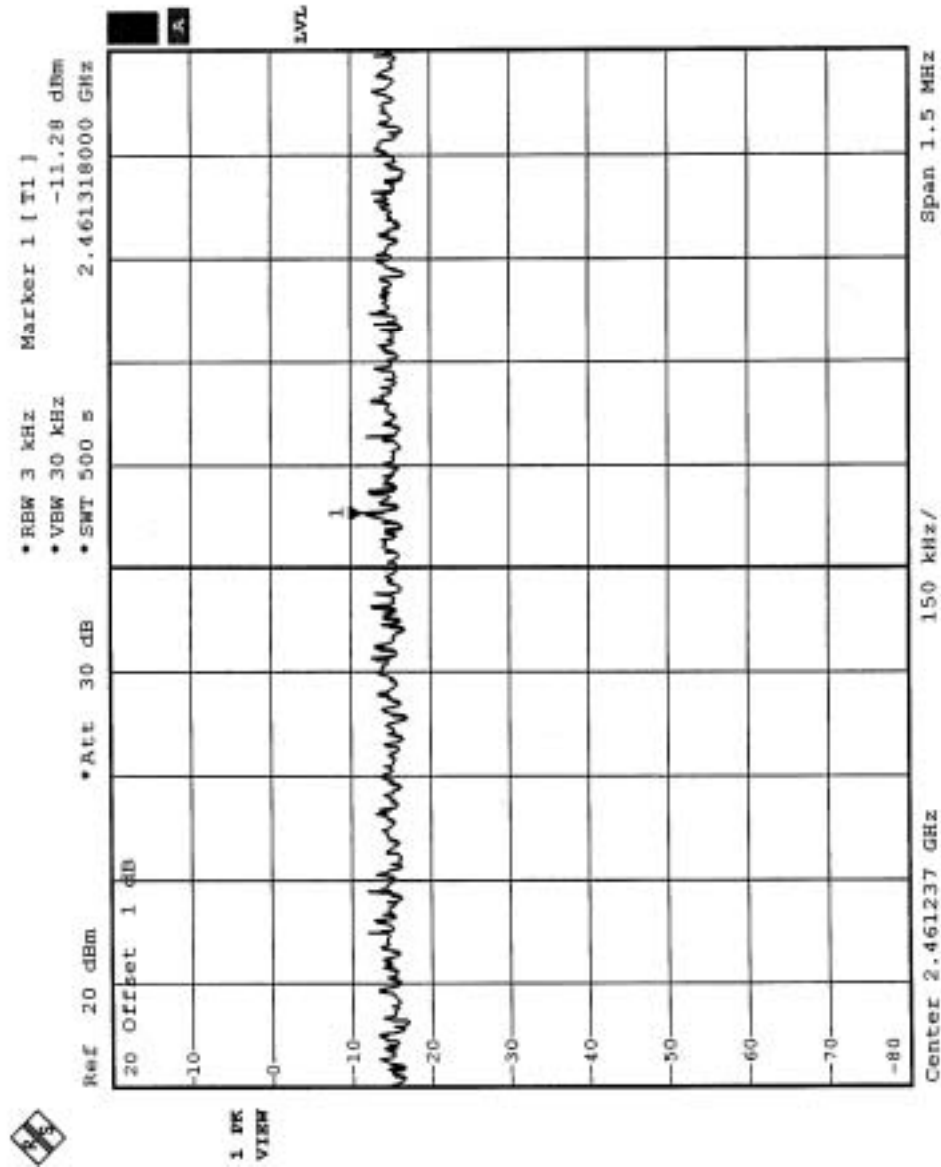



## 4.5.8 TEST RESULTS(B)

|                             |  |                                 |                         |
|-----------------------------|--|---------------------------------|-------------------------|
| <b>EUT</b>                  | Wireless Dual Band Enterprise Access Point | <b>MODEL</b>                    | RBT3K-AG                |
| <b>INPUT POWER (SYSTEM)</b> | 120Vac, 60Hz                               | <b>ENVIRONMENTAL CONDITIONS</b> | 21deg. C, 58RH, 974 hPa |
| <b>TESTED BY</b>            | Eric Lee                                   |                                 |                         |

| <b>CHANNEL NUMBER</b> | <b>CHANNEL FREQUENCY (MHz )</b> | <b>RF POWER LEVEL IN 3 kHz BW (dBm)</b> | <b>MAXIMUM LIMIT (dBm)</b> | <b>PASS/FAIL</b> |
|-----------------------|---------------------------------|---|----------------------------|------------------|
| 1                     | 2412                            | -14.43                                  | 8                          | PASS             |
| 6                     | 2437                            | -10.49                                  | 8                          | PASS             |
| 11                    | 2462                            | -14.59                                  | 8                          | PASS             |



CH1

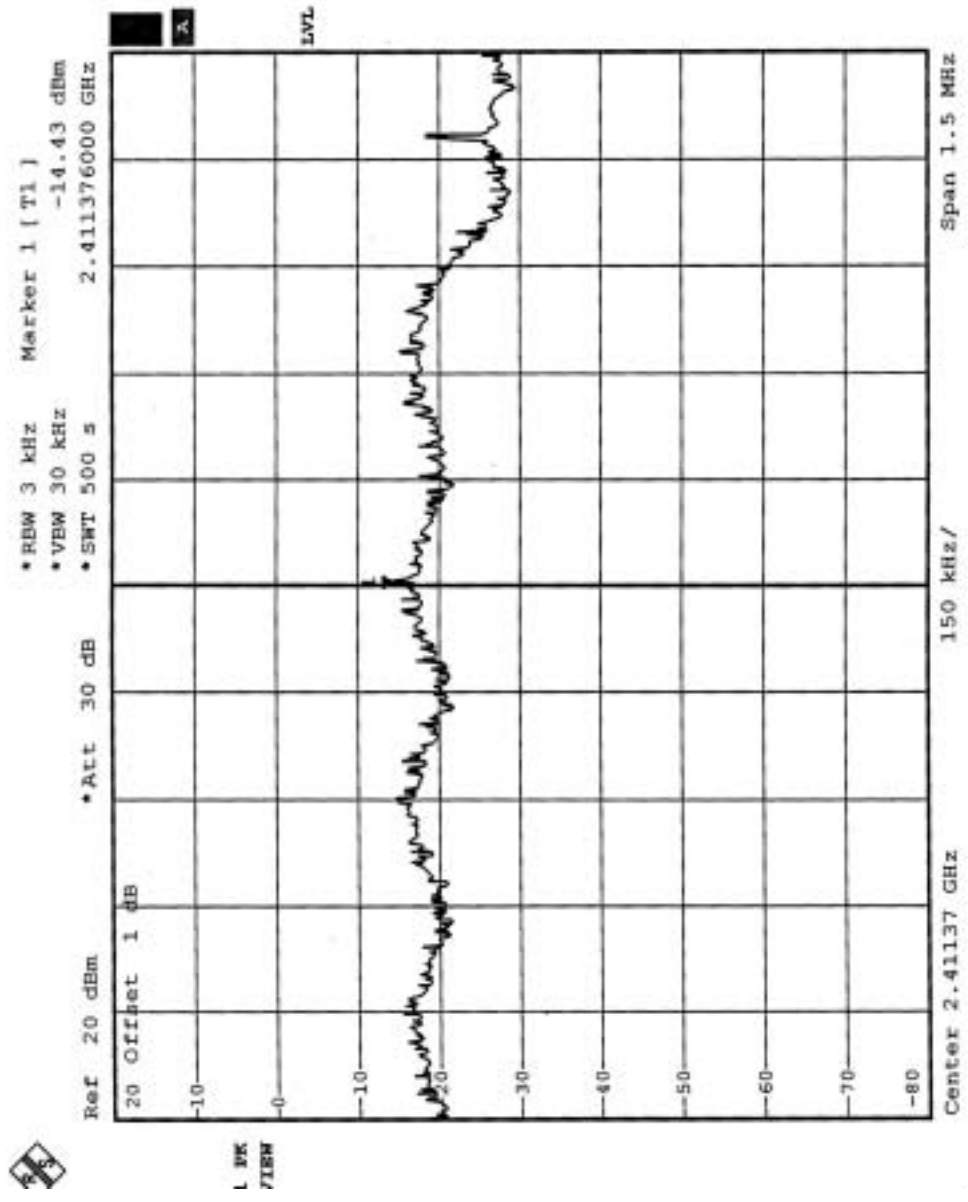



CH6

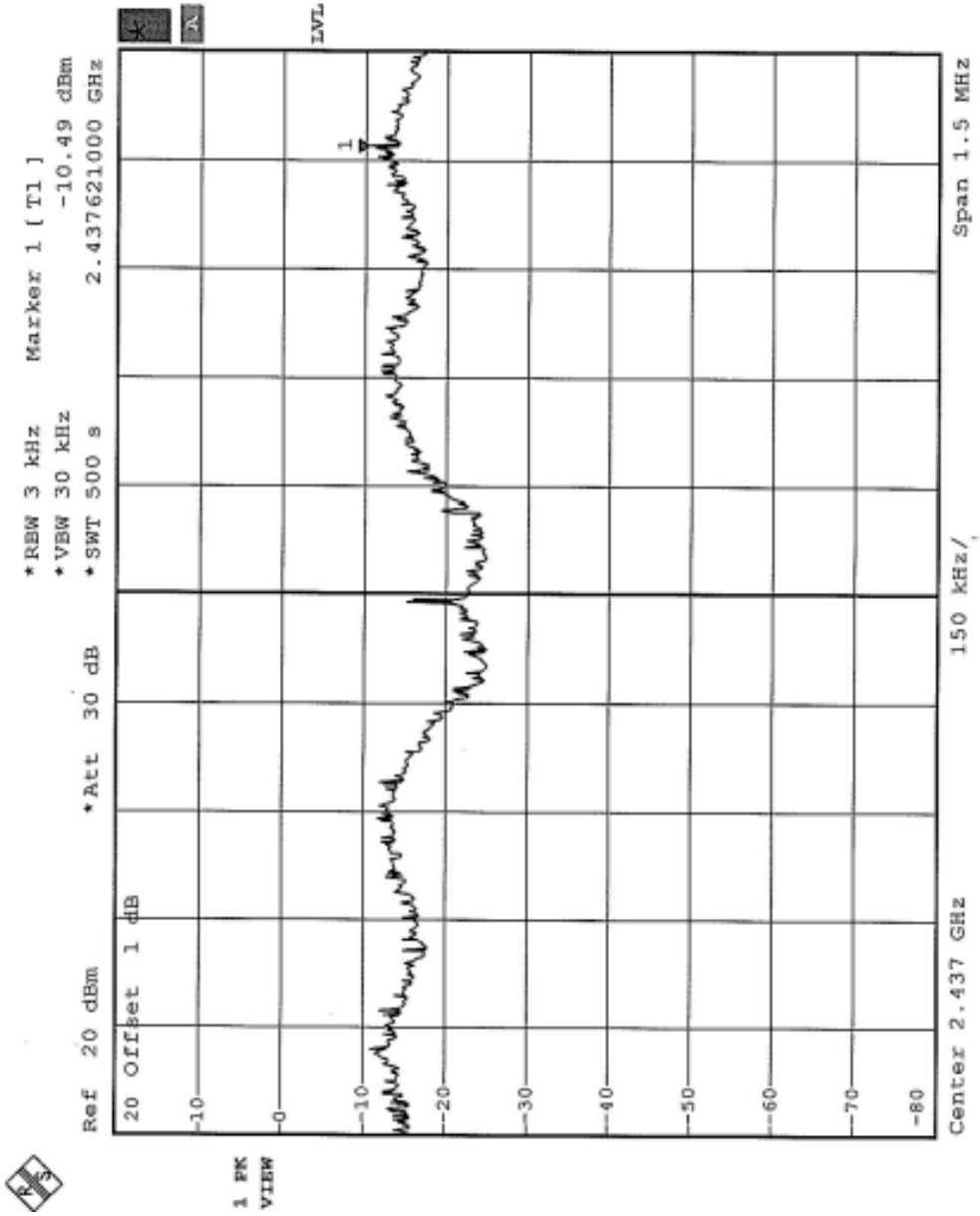





CH11

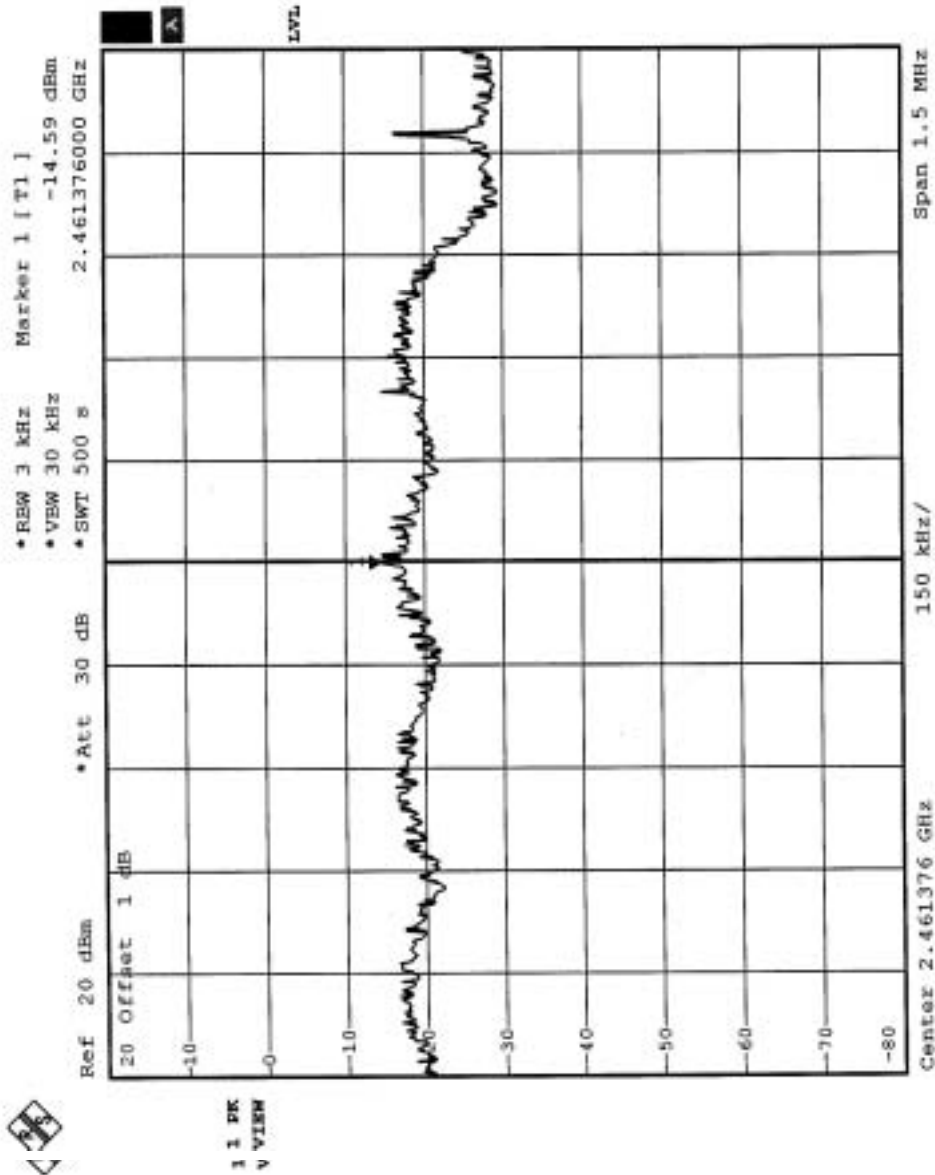



## 4.6 BAND EDGES MEASUREMENT

### 4.6.1 LIMITS OF BAND EDGES MEASUREMENT

Below  $-20\text{dB}$  of the highest emission level of operating band (in 100KHz Resolution Bandwidth).

### 4.6.2 TEST INSTRUMENTS

| Description & Manufacturer | Model No. | Serial No.   | Calibrated Until |
|----------------------------|-----------|--------------|------------------|
| R&S SPECTRUM ANALYZER      | FSP       | 1093.4495.30 | Dec. 19, 2003    |

**NOTE:**

- 1.The measurement uncertainty is less than  $\pm 2.6\text{dB}$ , which is calculated as per the NAMAS document NIS81.
- 2.The calibration interval of the above test instruments is 12 months and the calibrations are traceable to NML/ROC and NIST/USA.

### 4.6.3 TEST PROCEDURE

The transmitter output was connected to the spectrum analyzer via a low lose cable. Set both RBW and VBW of spectrum analyzer to 100 kHz with suitable frequency span including 100 kHz bandwidth from band edge. The band edges was measured and recorded.

### 4.6.4 DEVIATION FROM TEST STANDARD

No deviation



#### 4.6.5 EUT OPERATING CONDITION

Same as Item 4.3.6

#### 4.6.6 TEST RESULTS (A)

The spectrum plots are attached on the following 2 pages. D1 line indicates the highest level, and D2 line indicates the 20dB offset below D2. It shows compliance with the requirement in part 15.247(C).

**NOTE (1):** The band edge emission plot on the following first page shows 47.87dB delta between carrier maximum power and local maximum emission in restrict band (2.3900GHz). The emission of carrier strength list in the test result of channel 1 at the item 4.2 is 100.8dBuV/m, so the maximum field strength in restrict band is  $100.8-47.87=52.93$ dBuV/m which is under 54 dBuV/m limit.

**NOTE (2):** The band edge emission plot on the following second page shows 50.57 dB delta between carrier maximum power and local maximum emission in restrict band (2.496GHz). The emission of carrier strength list in the test result of channel 11 at the item 4.2 is 101.0dBuV/m, so the maximum field strength in restrict band is  $101.0-50.57=50.43$ dBuV/m which is under 54 dBuV/m limit.

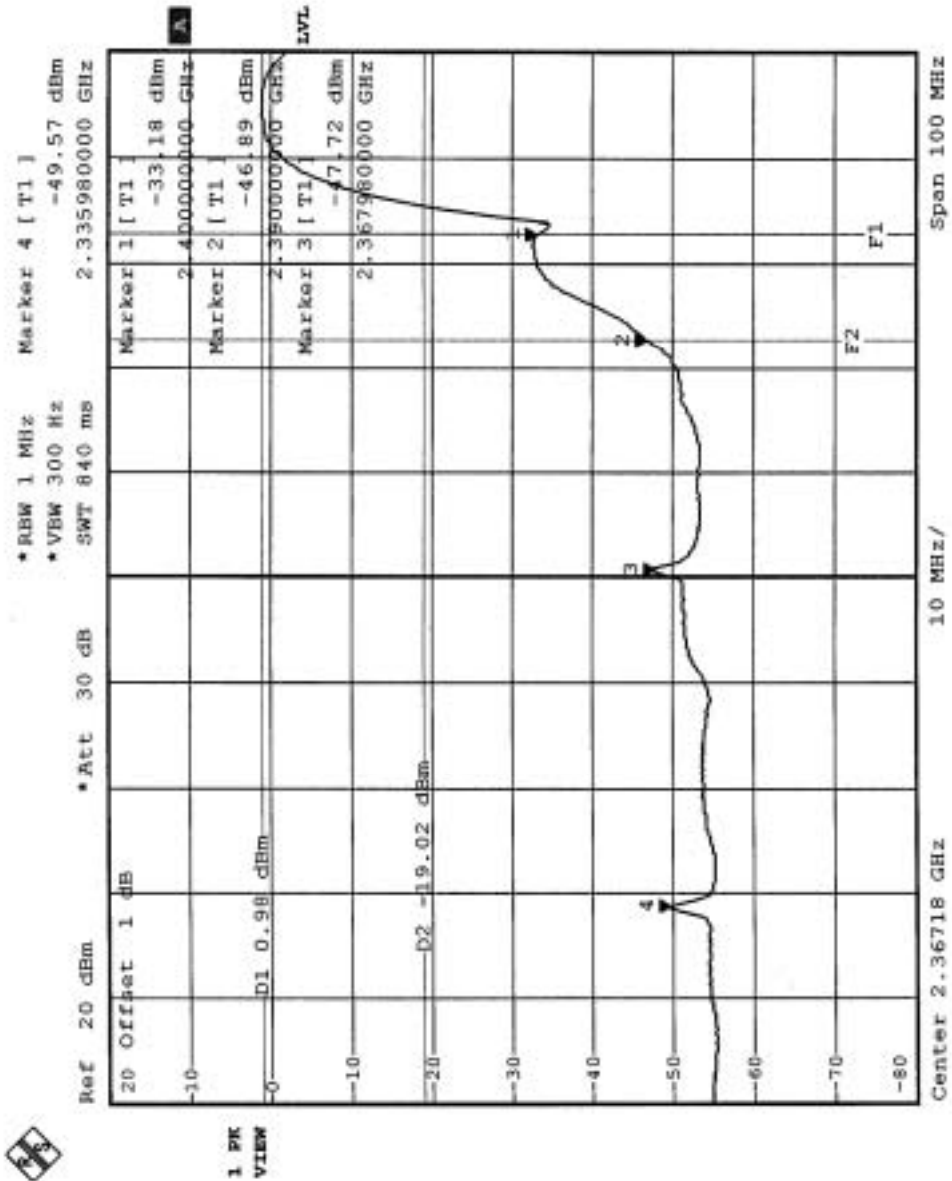

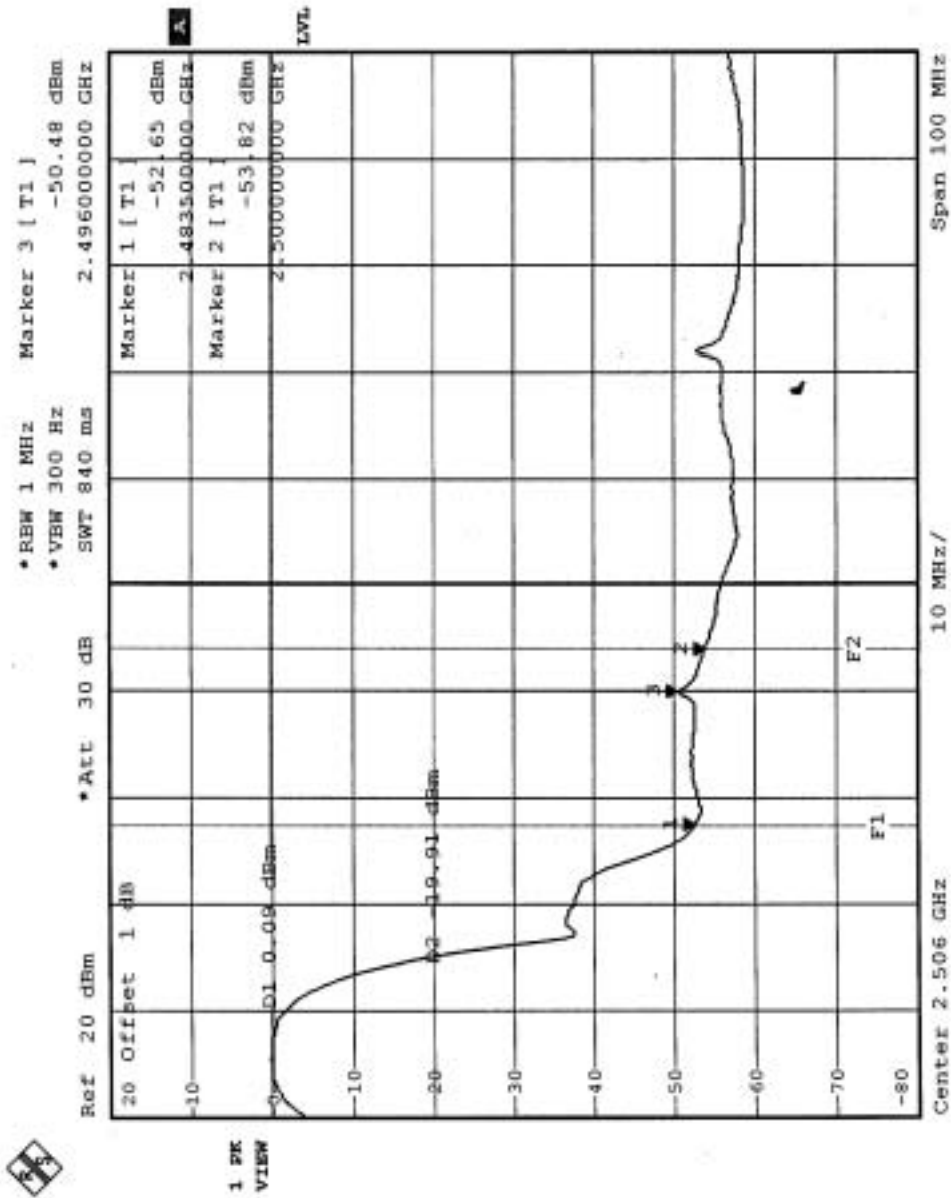



#### 4.6.7 TEST RESULTS (B)

The spectrum plots are attached on the following 2 pages. D1 line indicates the highest level, and D2 line indicates the 20dB offset below D1. It shows compliance with the requirement in part 15.247(C).

**NOTE (1):** The band edge emission plot on the following first page shows 43.23dB delta between carrier maximum power and local maximum emission in restrict band (2.390GHz). The emission of carrier strength list in the test result of channel 1 at the item 4.2 is 93.8dBuV/m, so the maximum field strength in restrict band is  $93.8-43.23=50.57$ dBuV/m which is under 54 dBuV/m limit.

**NOTE (2):** The band edge emission plot on the following second page shows 44.45 dB delta between carrier maximum power and local maximum emission in restrict band (2.4836GHz). The emission of carrier strength list in the test result of channel 11 at the item 4.2 is 94.1dBuV/m, so the maximum field strength in restrict band is  $94.1-44.45=49.65$  dBuV/m which is under 54 dBuV/m limit.

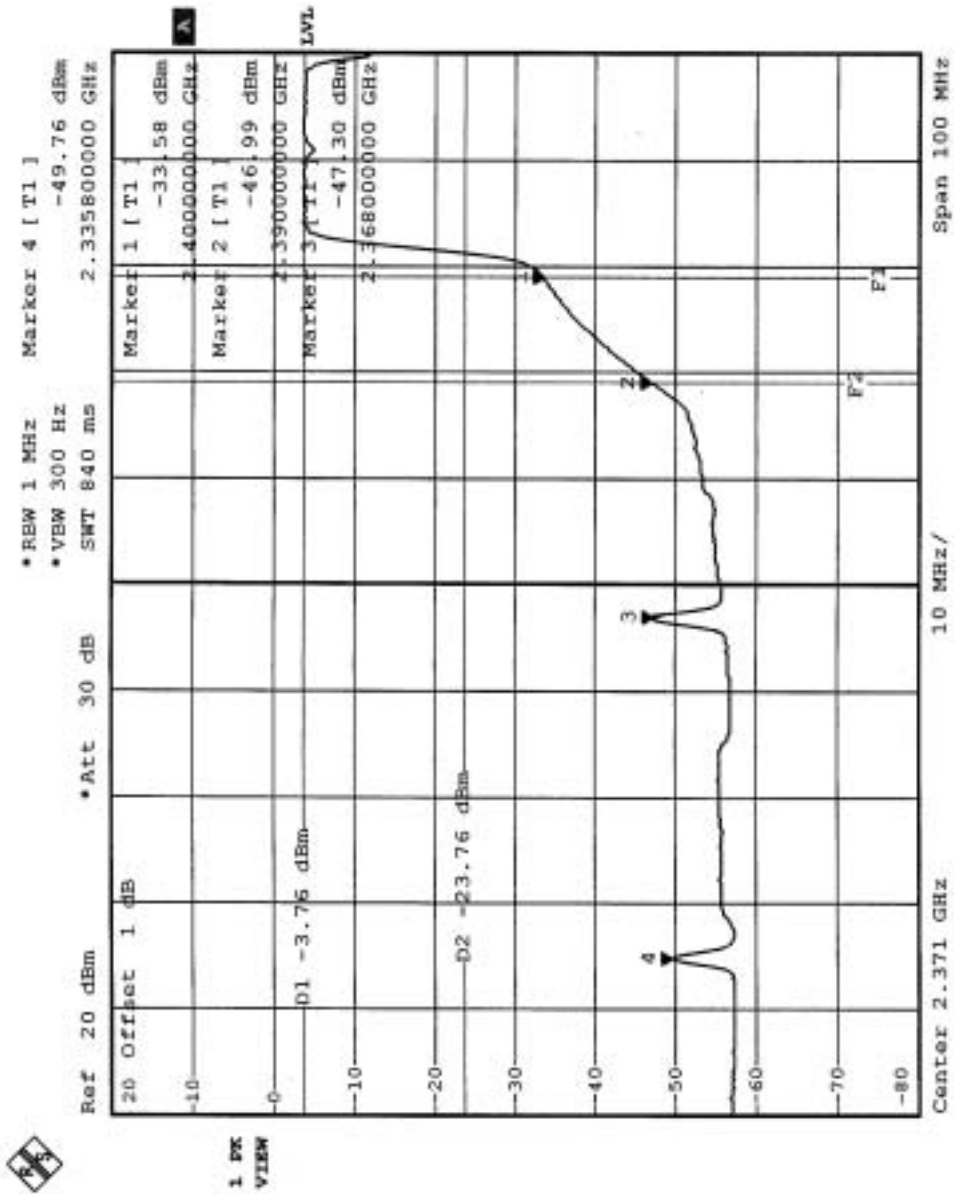

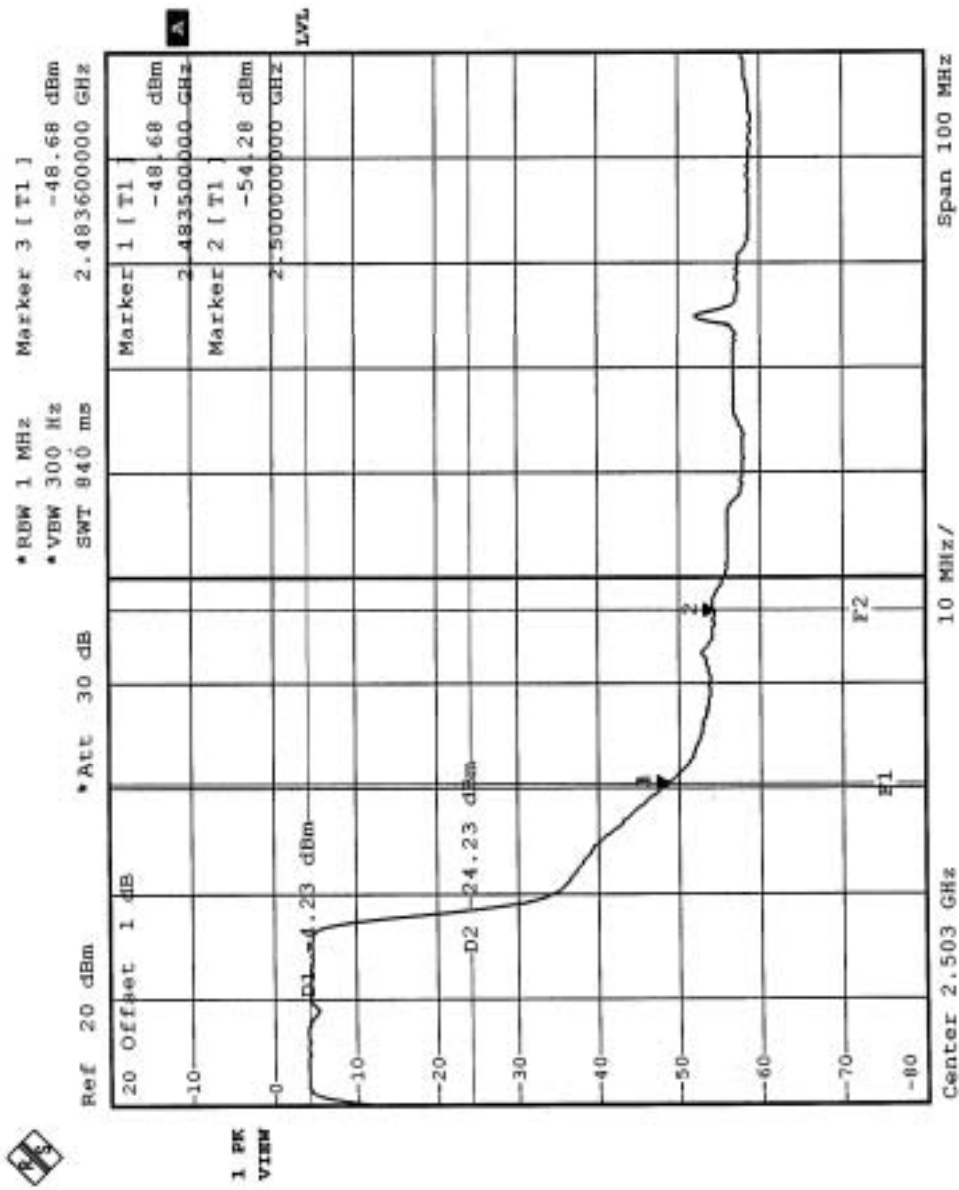





## **4.7 ANTENNA REQUIREMENT**

### **4.7.1 STANDARD APPLICABLE**

For intentional device, according to FCC 47 CFR Section 15.203, an intentional radiator shall be designed to ensure that no antenna other than that furnished by the responsible party shall be used with the device. And according to FCC 47 CFR Section 15.247 (b), if transmitting antennas of directional gain greater than 6dBi are used, the power shall be reduced by the amount in dB that the directional gain of the antenna exceeds 6dBi.

### **4.7.2 ANTENNA CONNECTED CONSTRUCTION**

The antenna used in this product is Dual-Band Omni-Directional Antenna with HRS U.FL-LP-066 connector. The maximum Gain of the antenna is 1.5dBi.



## 5. TEST TYPES AND RESULTS (FOR PART 802.11a)

### 5.1 CONDUCTED EMISSION MEASUREMENT

#### 5.1.1 LIMITS OF CONDUCTED EMISSION MEASUREMENT

| FREQUENCY OF EMISSION (MHz) | CONDUCTED LIMIT (dB $\mu$ V) |          |
|-----------------------------|------------------------------|----------|
|                             | Quasi-peak                   | Average  |
| 0.15-0.5                    | 66 to 56                     | 56 to 46 |
| 0.5-5                       | 56                           | 46       |
| 5-30                        | 60                           | 50       |

- NOTE:**
1. The lower limit shall apply at the transition frequencies.
  2. The limit decreases in line with the logarithm of the frequency in the range of 0.15 to 0.50 MHz.
  3. All emanations from a class A/B digital device or system, including any network of conductors and apparatus connected thereto, shall not exceed the level of field strengths specified above.

#### 5.1.2 TEST INSTRUMENTS

| DESCRIPTION & MANUFACTURER        | MODEL NO. | SERIAL NO.  | CALIBRATED UNTIL |
|-----------------------------------|-----------|-------------|------------------|
| ROHDE & SCHWARZ<br>Test Receiver  | ESCS 30   | 847124/029  | Nov. 17, 2003    |
| ROHDE & SCHWARZ LISN<br>(for EUT) | ESHS-Z5   | 848773/004  | Nov. 13, 2003    |
| KYORITSU LISN (for peripheral)    | KNW-407   | 8/1395/12   | Jul. 23, 2004    |
| RF Cable (JETBAO)                 | RG233/U   | Cable_CA_01 | Jul. 03, 2004    |
| Terminator(for KYORITSU)          | 50        | 3           | Apr. 11, 2004    |
| Software                          | Cond-V2e  | NA          | NA               |

- NOTE: 1. The calibration interval of the above test instruments is 12 months and the calibrations are traceable to NML/ROC and NIST/USA.
3. The test was performed in ADT Shielded Room No. A.
3. The VCCI Con A Registration No. is C-817.



### 5.1.3 TEST PROCEDURES

- a. The EUT was placed 0.4 meters from the conducting wall of the shielded room with EUT being connected to the power mains through a line impedance stabilization network (LISN). Other support units were connected to the power mains through another LISN. The two LISNs provide 50 ohm/ 50uH of coupling impedance for the measuring instrument.
- b. Both lines of the power mains connected to the EUT were checked for maximum conducted interference.
- c. The frequency range from 150 kHz to 30 MHz was searched. Emission levels over 10dB under the prescribed limits could not be reported

### 5.1.4 DEVIATION FROM TEST STANDARD

No deviation

### 5.1.5 TEST SETUP

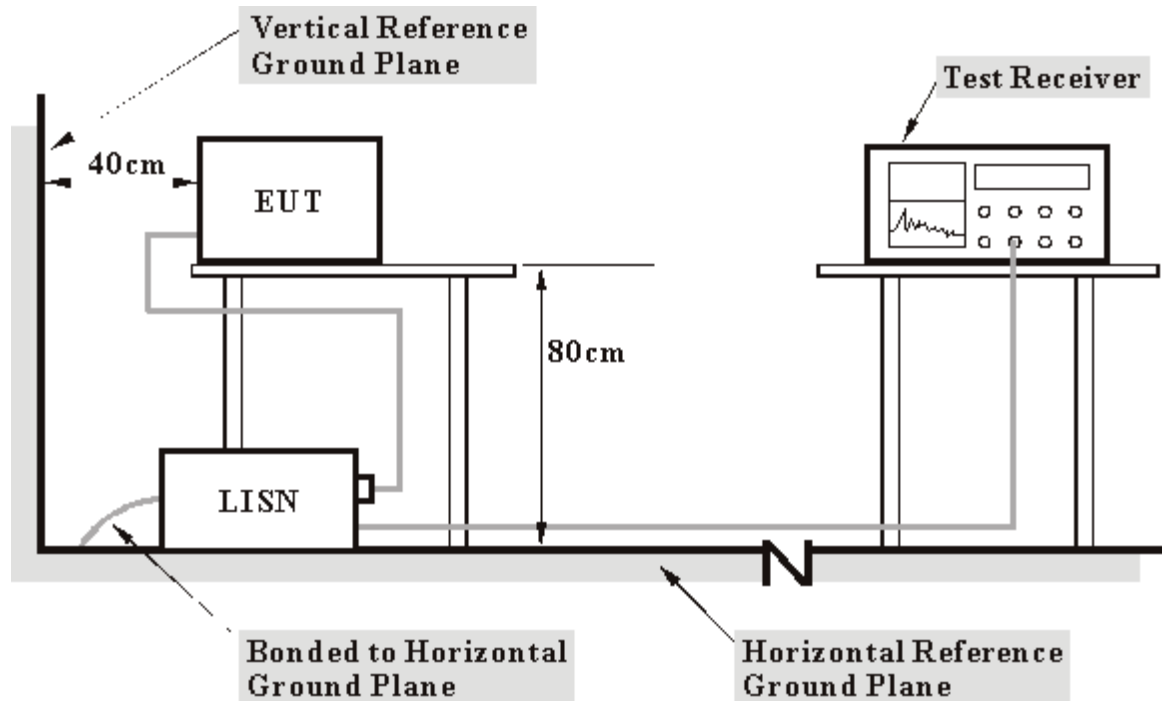

- Note:**
1. Support units were connected to second LISN.
  2. Both of LISNs (AMN) 80 cm from EUT and at the least 80 cm from other units and other metal planes support units.

For the actual test configuration, please refer to the related item – Photographs of the Test Configuration.

### 5.1.6 EUT OPERATING CONDITIONS

Same as 4.1.6.



### 5.1.7 TEST RESULTS

|                                 |  |                      |            |
|---------------------------------|--|----------------------|------------|
| <b>EUT</b>                      | Wireless Dual Band Enterprise Access Point |                      |            |
| <b>MODEL</b>                    | RBT3K-AG                                   | <b>6dB BANDWIDTH</b> | 9 kHz      |
| <b>INPUT POWER (SYSTEM)</b>     | 120Vac, 60 Hz                              | <b>PHASE</b>         | Line (L)   |
| <b>ENVIRONMENTAL CONDITIONS</b> | 27deg. C, 69RH, 976 hPa                    | <b>TESTED BY</b>     | Larry Peng |
| <b>TEST MODE</b>                | 802.11a, With Adapter                      |                      |            |

| No | Freq. [MHz] | Corr. Factor (dB) | Reading Value [dB (uV)] |     | Emission Level [dB (uV)] |     | Limit [dB (uV)] |       | Margin (dB) |     |
|----|-------------|-------------------|-------------------------|-----|--------------------------|-----|-----------------|-------|-------------|-----|
|    |             |                   | Q.P.                    | AV. | Q.P.                     | AV. | Q.P.            | AV.   | Q.P.        | AV. |
| 1  | 0.154       | 0.20              | 51.05                   | -   | 51.25                    | -   | 65.79           | 55.79 | -14.54      | -   |
| 2  | 0.189       | 0.20              | 34.06                   | -   | 34.26                    | -   | 64.08           | 54.08 | -29.82      | -   |
| 3  | 0.322       | 0.20              | 29.45                   | -   | 29.65                    | -   | 59.66           | 49.66 | -30.01      | -   |
| 4  | 0.670       | 0.24              | 20.65                   | -   | 20.89                    | -   | 56.00           | 46.00 | -35.11      | -   |
| 5  | 10.809      | 0.85              | 36.25                   | -   | 37.10                    | -   | 60.00           | 50.00 | -22.90      | -   |
| 6  | 16.426      | 1.13              | 45.60                   | -   | 46.73                    | -   | 60.00           | 50.00 | -13.27      | -   |

- NOTES: (1) "-": Undetectable  
 (2) Q.P. and AV. are abbreviations of quasi-peak and average.  
 (3) "-": The Quasi-peak reading value also meets an average limit, thus measurement with the average detector is unnecessary.  
 (4) The emission levels of other frequencies were very low against the limit.  
 (5) Correction Factor = Insertion loss + Cable loss  
 (6) Margin value = Emission level - Limit value

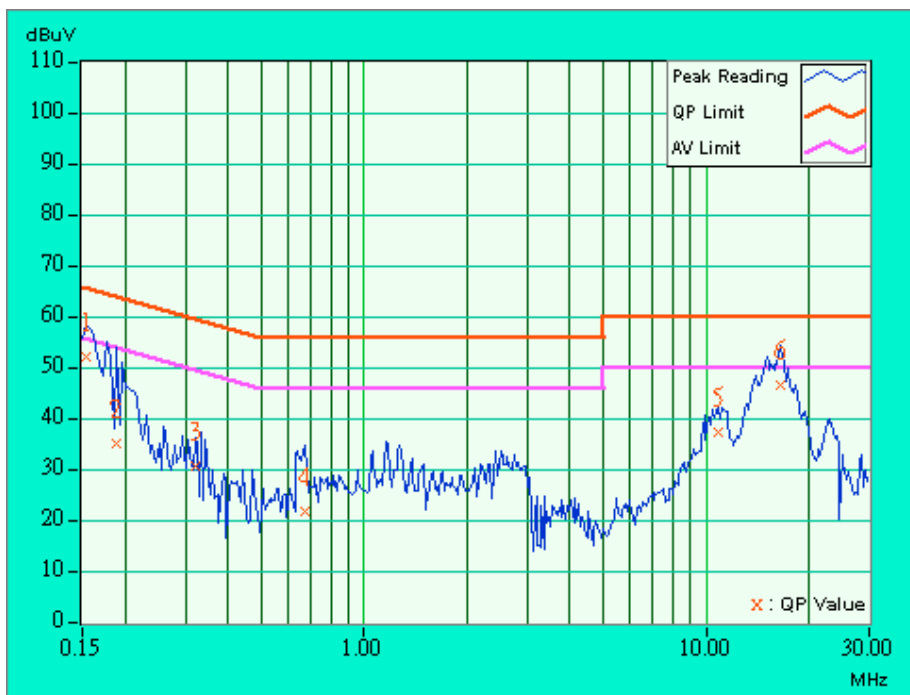



|                                 |  |                      |             |
|---------------------------------|--|----------------------|-------------|
| <b>EUT</b>                      | Wireless Dual Band Enterprise Access Point |                      |             |
| <b>MODEL</b>                    | RBT3K-AG                                   | <b>6dB BANDWIDTH</b> | 9 kHz       |
| <b>INPUT POWER (SYSTEM)</b>     | 120Vac, 60 Hz                              | <b>PHASE</b>         | Neutral (N) |
| <b>ENVIRONMENTAL CONDITIONS</b> | 27deg. C, 69RH, 976 hPa                    | <b>TESTED BY</b>     | Larry Peng  |
| <b>TEST MODE</b>                | 802.11a, With Adapter                      |                      |             |

| No | Freq. [MHz] | Corr. Factor (dB) | Reading Value [dB (uV)] |       | Emission Level [dB (uV)] |       | Limit [dB (uV)] |       | Margin (dB) |       |
|----|-------------|-------------------|-------------------------|-------|--------------------------|-------|-----------------|-------|-------------|-------|
|    |             |                   | Q.P.                    | AV.   | Q.P.                     | AV.   | Q.P.            | AV.   | Q.P.        | AV.   |
|    |             |                   | 1                       | 0.158 | 0.20                     | 51.92 | -               | 52.12 | -           | 65.58 |
| 2  | 0.201       | 0.20              | 42.39                   | -     | 42.59                    | -     | 63.58           | 53.58 | -20.99      | -     |
| 3  | 0.670       | 0.24              | 21.37                   | -     | 21.61                    | -     | 56.00           | 46.00 | -34.39      | -     |
| 4  | 1.170       | 0.30              | 33.58                   | -     | 33.88                    | -     | 56.00           | 46.00 | -22.12      | -     |
| 5  | 10.832      | 0.73              | 36.61                   | -     | 37.34                    | -     | 60.00           | 50.00 | -22.66      | -     |
| 6  | 16.234      | 0.90              | 45.66                   | -     | 46.56                    | -     | 60.00           | 50.00 | -13.44      | -     |

- NOTES: (1) "\*": Undetectable  
 (2) Q.P. and AV. are abbreviations of quasi-peak and average.  
 (3) "-": The Quasi-peak reading value also meets an average limit, thus measurement with the average detector is unnecessary.  
 (4) The emission levels of other frequencies were very low against the limit.  
 (5) Correction Factor = Insertion loss + Cable loss  
 (6) Margin value = Emission level - Limit value

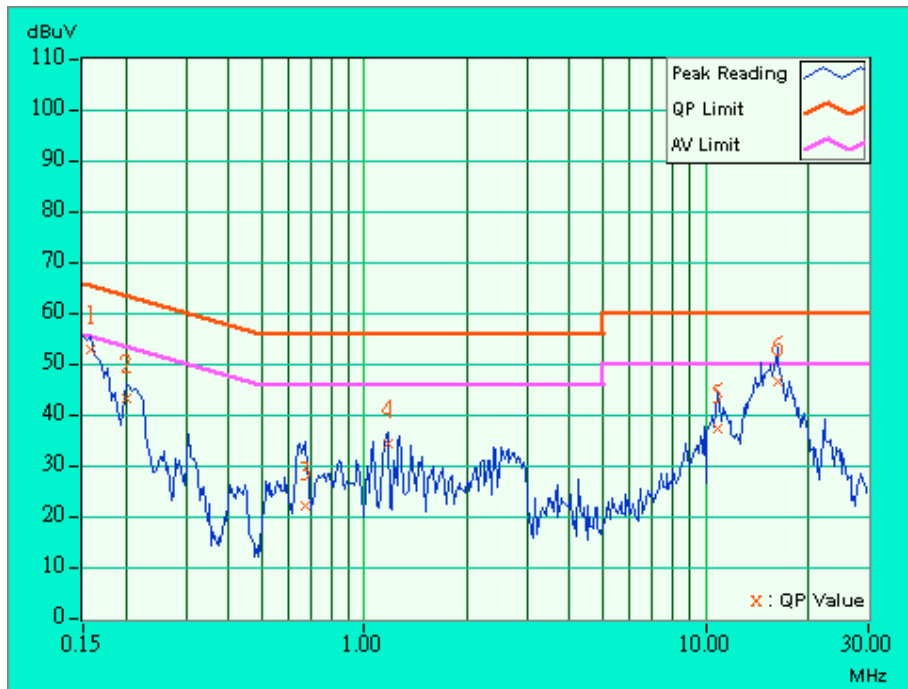



|                                 |  |                      |            |
|---------------------------------|--|----------------------|------------|
| <b>EUT</b>                      | Wireless Dual Band Enterprise Access Point |                      |            |
| <b>MODEL</b>                    | RBT3K-AG                                   | <b>6dB BANDWIDTH</b> | 9 kHz      |
| <b>INPUT POWER (SYSTEM)</b>     | 120Vac, 60 Hz                              | <b>PHASE</b>         | Line (L)   |
| <b>ENVIRONMENTAL CONDITIONS</b> | 27deg. C, 69RH, 976 hPa                    | <b>TESTED BY</b>     | Larry Peng |
| <b>TEST MODE</b>                | 802.11a, With POE                          |                      |            |

| No | Freq. [MHz] | Corr. Factor (dB) | Reading Value [dB (uV)] |     | Emission Level [dB (uV)] |     | Limit [dB (uV)] |       | Margin (dB) |     |
|----|-------------|-------------------|-------------------------|-----|--------------------------|-----|-----------------|-------|-------------|-----|
|    |             |                   | Q.P.                    | AV. | Q.P.                     | AV. | Q.P.            | AV.   | Q.P.        | AV. |
| 1  | 0.197       | 0.20              | 39.93                   | -   | 40.13                    | -   | 63.74           | 53.74 | -23.61      | -   |
| 2  | 0.400       | 0.20              | 36.84                   | -   | 37.04                    | -   | 57.85           | 47.85 | -20.81      | -   |
| 3  | 0.677       | 0.25              | 40.03                   | -   | 40.28                    | -   | 56.00           | 46.00 | -15.72      | -   |
| 4  | 1.017       | 0.30              | 42.40                   | -   | 42.70                    | -   | 56.00           | 46.00 | -13.30      | -   |
| 5  | 1.353       | 0.30              | 38.48                   | -   | 38.78                    | -   | 56.00           | 46.00 | -17.22      | -   |
| 6  | 9.695       | 0.78              | 31.63                   | -   | 32.41                    | -   | 60.00           | 50.00 | -27.59      | -   |

- NOTES: (1) "\*\*": Undetectable  
 (2) Q.P. and AV. are abbreviations of quasi-peak and average.  
 (3) "-": The Quasi-peak reading value also meets an average limit, thus measurement with the average detector is unnecessary.  
 (4) The emission levels of other frequencies were very low against the limit.  
 (5) Correction Factor = Insertion loss + Cable loss  
 (6) Margin value = Emission level - Limit value

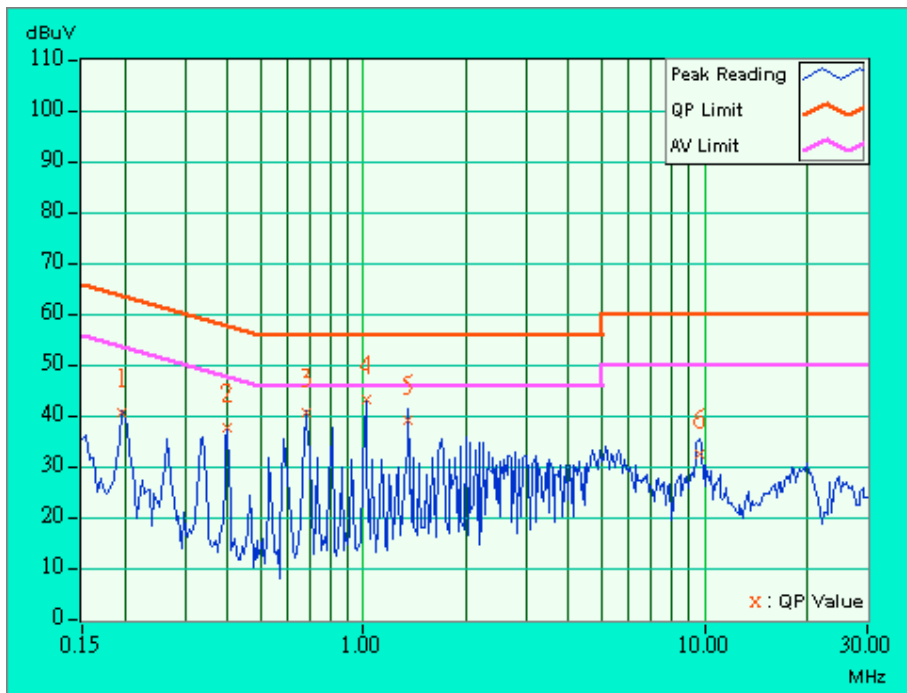



|                                 |  |                      |             |
|---------------------------------|--|----------------------|-------------|
| <b>EUT</b>                      | Wireless Dual Band Enterprise Access Point |                      |             |
| <b>MODEL</b>                    | RBT3K-AG                                   | <b>6dB BANDWIDTH</b> | 9 kHz       |
| <b>INPUT POWER (SYSTEM)</b>     | 120Vac, 60 Hz                              | <b>PHASE</b>         | Neutral (N) |
| <b>ENVIRONMENTAL CONDITIONS</b> | 27deg. C, 69RH, 976 hPa                    | <b>TESTED BY</b>     | Larry Peng  |
| <b>TEST MODE</b>                | 802.11a, With POE                          |                      |             |

| No | Freq. [MHz] | Corr. Factor (dB) | Reading Value [dB (uV)] |       | Emission Level [dB (uV)] |       | Limit [dB (uV)] |       | Margin (dB) |       |
|----|-------------|-------------------|-------------------------|-------|--------------------------|-------|-----------------|-------|-------------|-------|
|    |             |                   | Q.P.                    | AV.   | Q.P.                     | AV.   | Q.P.            | AV.   | Q.P.        | AV.   |
|    |             |                   | 1                       | 0.193 | 0.20                     | 34.48 | -               | 34.68 | -           | 63.91 |
| 2  | 0.400       | 0.20              | 35.95                   | -     | 36.15                    | -     | 57.85           | 47.85 | -21.70      | -     |
| 3  | 0.677       | 0.25              | 40.99                   | -     | 41.24                    | -     | 56.00           | 46.00 | -14.76      | -     |
| 4  | 1.017       | 0.30              | 43.22                   | -     | 43.52                    | -     | 56.00           | 46.00 | -12.48      | -     |
| 5  | 1.357       | 0.30              | 36.24                   | -     | 36.54                    | -     | 56.00           | 46.00 | -19.46      | -     |
| 6  | 9.837       | 0.69              | 34.36                   | -     | 35.05                    | -     | 60.00           | 50.00 | -24.95      | -     |

- NOTES: (1) "\*": Undetectable  
 (2) Q.P. and AV. are abbreviations of quasi-peak and average.  
 (3) "-": The Quasi-peak reading value also meets an average limit, thus measurement with the average detector is unnecessary.  
 (4) The emission levels of other frequencies were very low against the limit.  
 (5) Correction Factor = Insertion loss + Cable loss  
 (6) Margin value = Emission level - Limit value

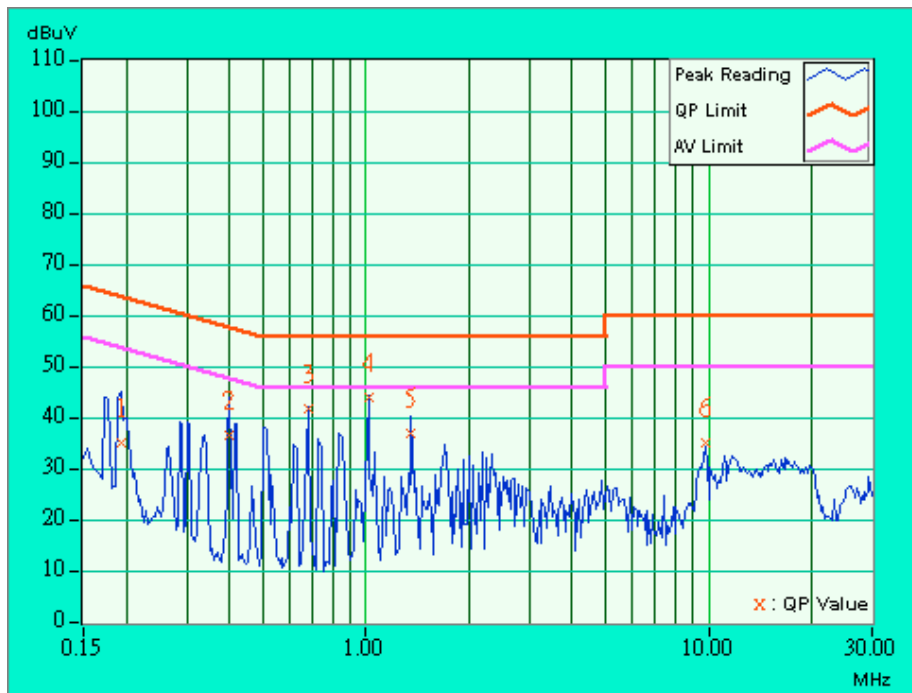





|                                 |  |                      |            |
|---------------------------------|--|----------------------|------------|
| <b>EUT</b>                      | Wireless Dual Band Enterprise Access Point |                      |            |
| <b>MODEL</b>                    | RBT3K-AG                                   | <b>6dB BANDWIDTH</b> | 9 kHz      |
| <b>INPUT POWER (SYSTEM)</b>     | 120Vac, 60 Hz                              | <b>PHASE</b>         | Line (L)   |
| <b>ENVIRONMENTAL CONDITIONS</b> | 27deg. C, 69RH, 976 hPa                    | <b>TESTED BY</b>     | Larry Peng |
| <b>TEST MODE</b>                | 802.11a and draft 802.11g, With Adapter    |                      |            |

| No | Freq. [MHz] | Corr. Factor (dB) | Reading Value [dB (uV)] |       | Emission Level [dB (uV)] |       | Limit [dB (uV)] |       | Margin (dB) |       |
|----|-------------|-------------------|-------------------------|-------|--------------------------|-------|-----------------|-------|-------------|-------|
|    |             |                   | Q.P.                    | AV.   | Q.P.                     | AV.   | Q.P.            | AV.   | Q.P.        | AV.   |
|    |             |                   | 1                       | 0.158 | 0.20                     | 50.55 | -               | 50.75 | -           | 65.58 |
| 2  | 0.228       | 0.20              | 40.16                   | -     | 40.36                    | -     | 62.52           | 52.52 | -22.16      | -     |
| 3  | 1.162       | 0.30              | 28.43                   | -     | 28.73                    | -     | 56.00           | 46.00 | -27.27      | -     |
| 4  | 2.459       | 0.32              | 26.65                   | -     | 26.97                    | -     | 56.00           | 46.00 | -29.03      | -     |
| 5  | 10.789      | 0.85              | 36.61                   | -     | 37.46                    | -     | 60.00           | 50.00 | -22.54      | -     |
| 6  | 16.160      | 1.12              | 45.58                   | -     | 46.70                    | -     | 60.00           | 50.00 | -13.30      | -     |

- NOTES: (1) "\*": Undetectable  
 (2) Q.P. and AV. are abbreviations of quasi-peak and average.  
 (3) "-": The Quasi-peak reading value also meets an average limit, thus measurement with the average detector is unnecessary.  
 (4) The emission levels of other frequencies were very low against the limit.  
 (5) Correction Factor = Insertion loss + Cable loss  
 (6) Margin value = Emission level - Limit value

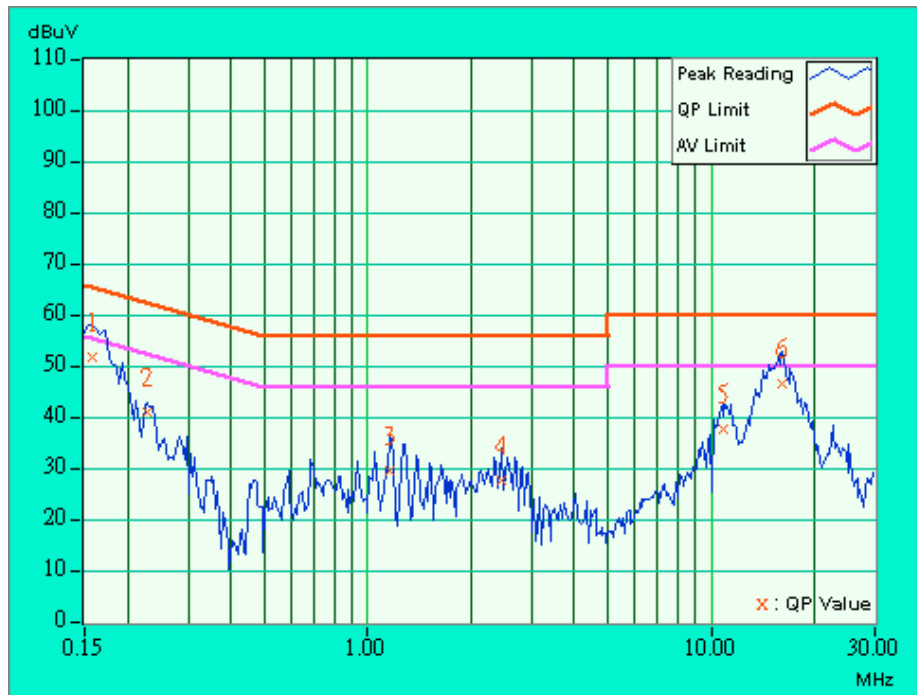



|                                 |  |                      |             |
|---------------------------------|--|----------------------|-------------|
| <b>EUT</b>                      | Wireless Dual Band Enterprise Access Point |                      |             |
| <b>MODEL</b>                    | RBT3K-AG                                   | <b>6dB BANDWIDTH</b> | 9 kHz       |
| <b>INPUT POWER (SYSTEM)</b>     | 120Vac, 60 Hz                              | <b>PHASE</b>         | Neutral (N) |
| <b>ENVIRONMENTAL CONDITIONS</b> | 27deg. C, 69RH, 976 hPa                    | <b>TESTED BY</b>     | Larry Peng  |
| <b>TEST MODE</b>                | 802.11a and draft 802.11g, With Adapter    |                      |             |

| No | Freq. [MHz] | Corr. Factor (dB) | Reading Value [dB (uV)] |       | Emission Level [dB (uV)] |       | Limit [dB (uV)] |       | Margin (dB) |       |
|----|-------------|-------------------|-------------------------|-------|--------------------------|-------|-----------------|-------|-------------|-------|
|    |             |                   | Q.P.                    | AV.   | Q.P.                     | AV.   | Q.P.            | AV.   | Q.P.        | AV.   |
|    |             |                   | 1                       | 0.166 | 0.20                     | 51.19 | -               | 51.39 | -           | 65.18 |
| 2  | 0.228       | 0.20              | 39.95                   | -     | 40.15                    | -     | 62.52           | 52.52 | -22.37      | -     |
| 3  | 1.170       | 0.30              | 34.18                   | -     | 34.48                    | -     | 56.00           | 46.00 | -21.52      | -     |
| 4  | 2.673       | 0.33              | 21.44                   | -     | 21.77                    | -     | 56.00           | 46.00 | -34.23      | -     |
| 5  | 11.023      | 0.74              | 37.38                   | -     | 38.12                    | -     | 60.00           | 50.00 | -21.88      | -     |
| 6  | 15.121      | 0.90              | 45.20                   | -     | 46.10                    | -     | 60.00           | 50.00 | -13.90      | -     |

- NOTES: (1) "\*": Undetectable  
 (2) Q.P. and AV. are abbreviations of quasi-peak and average.  
 (3) "-": The Quasi-peak reading value also meets an average limit, thus measurement with the average detector is unnecessary.  
 (4) The emission levels of other frequencies were very low against the limit.  
 (5) Correction Factor = Insertion loss + Cable loss  
 (6) Margin value = Emission level - Limit value

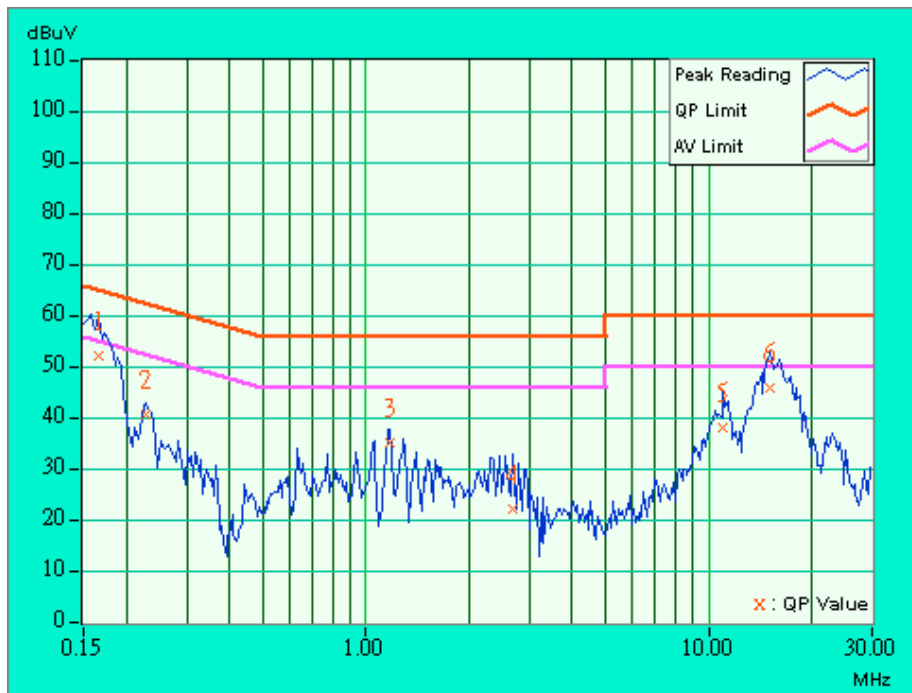



|                                 |  |                      |            |
|---------------------------------|--|----------------------|------------|
| <b>EUT</b>                      | Wireless Dual Band Enterprise Access Point |                      |            |
| <b>MODEL</b>                    | RBT3K-AG                                   | <b>6dB BANDWIDTH</b> | 9 kHz      |
| <b>INPUT POWER (SYSTEM)</b>     | 120Vac, 60 Hz                              | <b>PHASE</b>         | Line (L)   |
| <b>ENVIRONMENTAL CONDITIONS</b> | 27deg. C, 69RH, 976 hPa                    | <b>TESTED BY</b>     | Larry Peng |
| <b>TEST MODE</b>                | 802.11a and draft 802.11g, With POE        |                      |            |

| No       | Freq. [MHz]  | Corr. Factor (dB) | Reading Value [dB (uV)] |       | Emission Level [dB (uV)] |       | Limit [dB (uV)] |              | Margin (dB)   |       |
|----------|--------------|-------------------|-------------------------|-------|--------------------------|-------|-----------------|--------------|---------------|-------|
|          |              |                   | Q.P.                    | AV.   | Q.P.                     | AV.   | Q.P.            | AV.          | Q.P.          | AV.   |
|          |              |                   | 1                       | 0.166 | 0.20                     | 51.63 | -               | 51.83        | -             | 65.18 |
| 2        | 0.670        | 0.24              | 39.91                   | -     | 40.15                    | -     | 56.00           | 46.00        | -15.85        | -     |
| <b>3</b> | <b>1.338</b> | <b>0.30</b>       | <b>44.92</b>            | -     | <b>45.22</b>             | -     | <b>56.00</b>    | <b>46.00</b> | <b>-10.78</b> | -     |
| 4        | 4.258        | 0.42              | 37.91                   | -     | 38.33                    | -     | 56.00           | 46.00        | -17.67        | -     |
| 5        | 10.016       | 0.80              | 46.29                   | -     | 47.09                    | -     | 60.00           | 50.00        | -12.91        | -     |
| 6        | 14.379       | 1.06              | 47.67                   | -     | 48.73                    | -     | 60.00           | 50.00        | -11.27        | -     |

- NOTES: (1) "\*": Undetectable  
 (2) Q.P. and AV. are abbreviations of quasi-peak and average.  
 (3) "-": The Quasi-peak reading value also meets an average limit, thus measurement with the average detector is unnecessary.  
 (4) The emission levels of other frequencies were very low against the limit.  
 (5) Correction Factor = Insertion loss + Cable loss  
 (6) Margin value = Emission level - Limit value

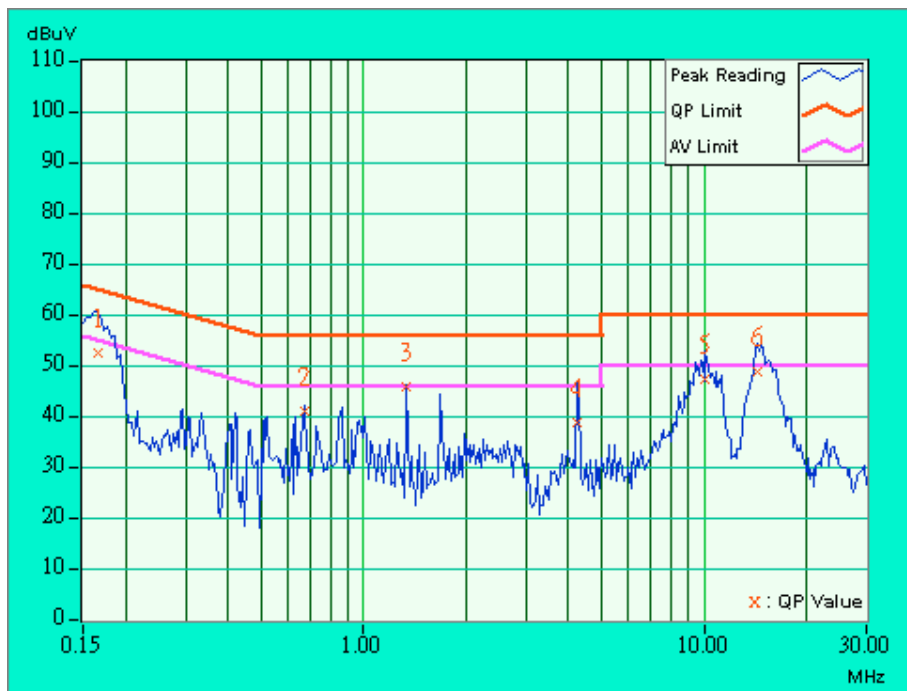



|                                 |  |                      |             |
|---------------------------------|--|----------------------|-------------|
| <b>EUT</b>                      | Wireless Dual Band Enterprise Access Point |                      |             |
| <b>MODEL</b>                    | RBT3K-AG                                   | <b>6dB BANDWIDTH</b> | 9 kHz       |
| <b>INPUT POWER (SYSTEM)</b>     | 120Vac, 60 Hz                              | <b>PHASE</b>         | Neutral (N) |
| <b>ENVIRONMENTAL CONDITIONS</b> | 27deg. C, 69RH, 976 hPa                    | <b>TESTED BY</b>     | Larry Peng  |
| <b>TEST MODE</b>                | 802.11a and draft 802.11g, With POE        |                      |             |

| No | Freq. [MHz] | Corr. Factor (dB) | Reading Value [dB (uV)] |       | Emission Level [dB (uV)] |       | Limit [dB (uV)] |       | Margin (dB) |       |
|----|-------------|-------------------|-------------------------|-------|--------------------------|-------|-----------------|-------|-------------|-------|
|    |             |                   | Q.P.                    | AV.   | Q.P.                     | AV.   | Q.P.            | AV.   | Q.P.        | AV.   |
|    |             |                   | 1                       | 0.166 | 0.20                     | 45.02 | -               | 45.22 | -           | 65.18 |
| 2  | 0.334       | 0.20              | 38.66                   | -     | 38.86                    | -     | 59.36           | 49.36 | -20.50      | -     |
| 3  | 0.670       | 0.24              | 39.47                   | -     | 39.71                    | -     | 56.00           | 46.00 | -16.29      | -     |
| 4  | 1.338       | 0.30              | 43.26                   | -     | 43.56                    | -     | 56.00           | 46.00 | -12.44      | -     |
| 5  | 9.625       | 0.68              | 43.67                   | -     | 44.35                    | -     | 60.00           | 50.00 | -15.65      | -     |
| 6  | 14.262      | 0.87              | 41.42                   | -     | 42.29                    | -     | 60.00           | 50.00 | -17.71      | -     |

- NOTES: (1) "\*": Undetectable  
 (2) Q.P. and AV. are abbreviations of quasi-peak and average.  
 (3) "-": The Quasi-peak reading value also meets an average limit, thus measurement with the average detector is unnecessary.  
 (4) The emission levels of other frequencies were very low against the limit.  
 (5) Correction Factor = Insertion loss + Cable loss  
 (6) Margin value = Emission level - Limit value

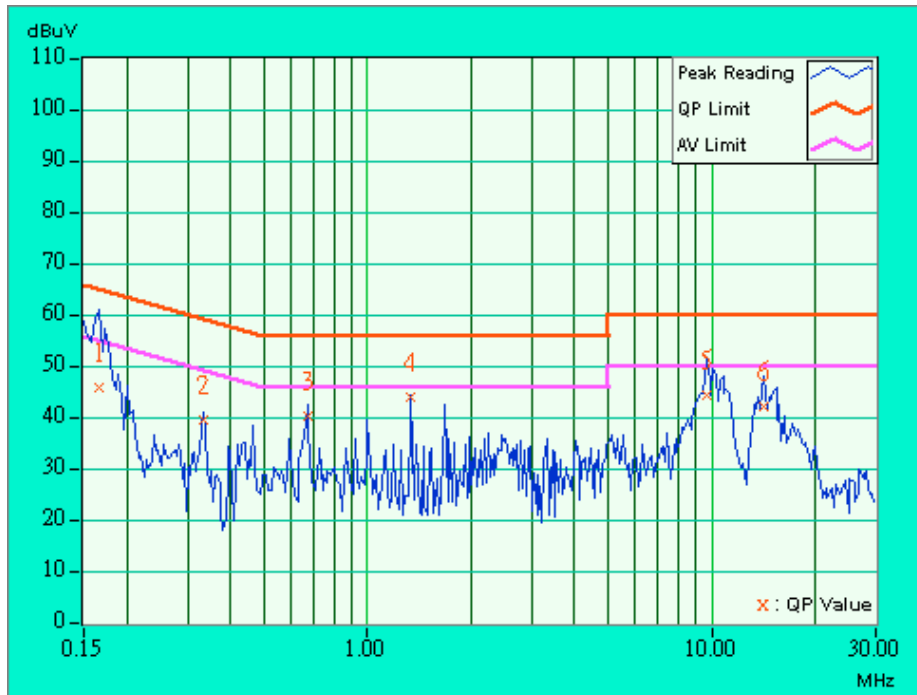



## 5.2 RADIATED EMISSION MEASUREMENT

### 5.2.1 LIMITS OF RADIATED EMISSION MEASUREMENT

Emissions radiated outside of the specified bands, shall be according to the general radiated limits in 15.209 as following:

| Frequencies (MHz) | Field strength (microvolts/meter) | Measurement distance (meters) |
|-------------------|-----------------------------------|-------------------------------|
| 0.009-0.490       | 2400/F(kHz)                       | 300                           |
| 0.490-1.705       | 24000/F(kHz)                      | 30                            |
| 1.705-30.0        | 30                                | 30                            |
| 30-88             | 100                               | 3                             |
| 88-216            | 150                               | 3                             |
| 216-960           | 200                               | 3                             |
| Above 960         | 500                               | 3                             |

**NOTE:**

1. The lower limit shall apply at the transition frequencies.
2. Emission level (dBuV/m) = 20 log Emission level (uV/m).
3. As shown in 15.35(b), for frequencies above 1000MHz, the field strength limits are based on average detector, however, the peak field strength of any emission shall not exceed the maximum permitted average limits, specified above by more than 20dB under any condition of modulation.



### 5.2.2 LIMITS OF UNWANTED EMISSION OUT OF THE RESTRICTED BANDS

| Frequencies (MHz) | EIRP Limit (dBm) | Equivalent Field Strength at 3m (dB $\mu$ V/m) *note 3 |
|-------------------|------------------|--|
| 5150~5250         | -27              | 68.3   |
| 5250~5350         | -27              | 68.3   |
| 5725~5825         | -27 *note 1      | 68.3   |
|                   | -17 *note 2      | 78.3   |

**NOTE:**

1. For frequencies 10MHz or greater above or below the band edge.
2. All emissions within the frequency range from the band edge to 10MHz above or below the band edge.
3. The following formula is used to convert the equipment isotropic radiated power (eirp) to field strength

$$E = \frac{1000000\sqrt{30P}}{3} \mu\text{V/m}, \quad \text{where P is the eirp (Watts)}$$



### 5.2.3 TEST INSTRUMENTS

| DESCRIPTION & MANUFACTURER            | MODEL NO. | SERIAL NO.              | CALIBRATED UNTIL |
|---------------------------------------|-----------|-------------------------|------------------|
| HP Spectrum Analyzer                  | 8594ER    | 3829U04676              | Jul. 14, 2004    |
| ADVANTEST Spectrum Analyzer           | R3271A    | 85060311                | May 21, 2004     |
| CHASE RF Pre_Amplifier                | CPA9232   | 1057                    | Apr. 24, 2004    |
| HP Pre_Amplifier                      | 8449B     | 3008A01281              | June 27, 2004    |
| ROHDE & SCHWARZ<br>Test Receiver      | ESVS 10   | 849231 /019             | Nov. 03, 2003    |
| CHASE Broadband Antenna               | CBL6111c  | 2730                    | Jul 17, 2004     |
| Schwarzbeck Horn_Antenna              | 3115      | 5619                    | Jul. 17, 2004    |
| Schwarzbeck Horn_Antenna              | BBHA 9170 | BBHA9170192             | Feb. 16, 2005    |
| SCHWARZBECK Tunable<br>Dipole Antenna | UHAP      | 897                     | Mar. 07, 2005    |
| SCHWARZBECK Tunable<br>Dipole Antenna | VHAP      | 880                     | Mar. 07, 2005    |
| RF Switches (ARNITSU)                 | CS-201    | 1565157                 | Dec. 01, 2003    |
| RF CABLE (Chaintek) 1GHz-20GHz        | SF102     | 22054-2                 | Feb. 10. 2004    |
| RF Cable(RICHTEC)                     | 9913-30M  | STCCAB-30M-<br>1GHz-021 | Nov. 5, 2003     |
| Software                              | AS60P8    | NA                      | NA               |
| CHANCE MOST<br>Antenna Tower          | AT-100    | 0203                    | NA               |
| CHANCE MOST Turn Table                | TT-100    | 0203                    | NA               |

Note: 1. The calibration interval of the above test instruments is 12 months (36 months for Tunable Dipole Antenna) and the calibrations are traceable to NML/ROC and NIST/USA.

2. \* = These equipment are used for the final measurement.
3. The horn antenna and HP preamplifier (model: 8449B) are used only for the measurement of emission frequency above 1GHz if tested.
4. The test was performed in ADT Open Site No. C.
5. The FCC Site Registration No. is 656396.
6. The VCCI Site Registration No. is R-1626.
7. The CANADA Site Registration No. is IC 3789-C.



#### 5.2.4 TEST PROCEDURES

- a. The EUT was placed on the top of a rotating table 0.8 meters above the ground at a 10 meter open area test site. The table was rotated 360 degrees to determine the position of the highest radiation.
- b. The EUT was set 3 meters away from the interference-receiving antenna, which was mounted on the top of a variable-height antenna tower.
- c. The antenna is a broadband antenna, and its height is varied from one meter to four meters above the ground to determine the maximum value of the field strength. Both horizontal and vertical polarizations of the antenna are set to make the measurement.
- d. For each suspected emission, the EUT was arranged to its worst case and then the antenna was tuned to heights from 1 meter to 4 meters and the rotatable table was turned from 0 degrees to 360 degrees to find the maximum reading.
- e. The test-receiver system was set to Peak Detect Function and Specified Bandwidth with Maximum Hold Mode.
- f. If the emission level of the EUT in peak mode was 10dB lower than the limit specified, then testing could be stopped and the peak values of the EUT would be reported. Otherwise the emissions that did not have 10dB margin would be re-tested one by one using peak, quasi-peak or average method as specified and then reported in a data sheet.

**NOTE:**

1. The resolution bandwidth and video bandwidth of test receiver/spectrum analyzer is 120kHz for Peak detection (PK) and Quasi-peak detection (QP) at frequency below 1GHz.
2. The resolution bandwidth and video bandwidth of test receiver/spectrum analyzer is 1 MHz for Peak detection at frequency above 1GHz.
3. The resolution bandwidth of test receiver/spectrum analyzer is 1 MHz and the video bandwidth is 300 Hz for Average detection (AV) at frequency above 1GHz.

#### 5.2.5 DEVIATION FROM TEST STANDARD

No deviation



## 5.2.6 TEST SETUP

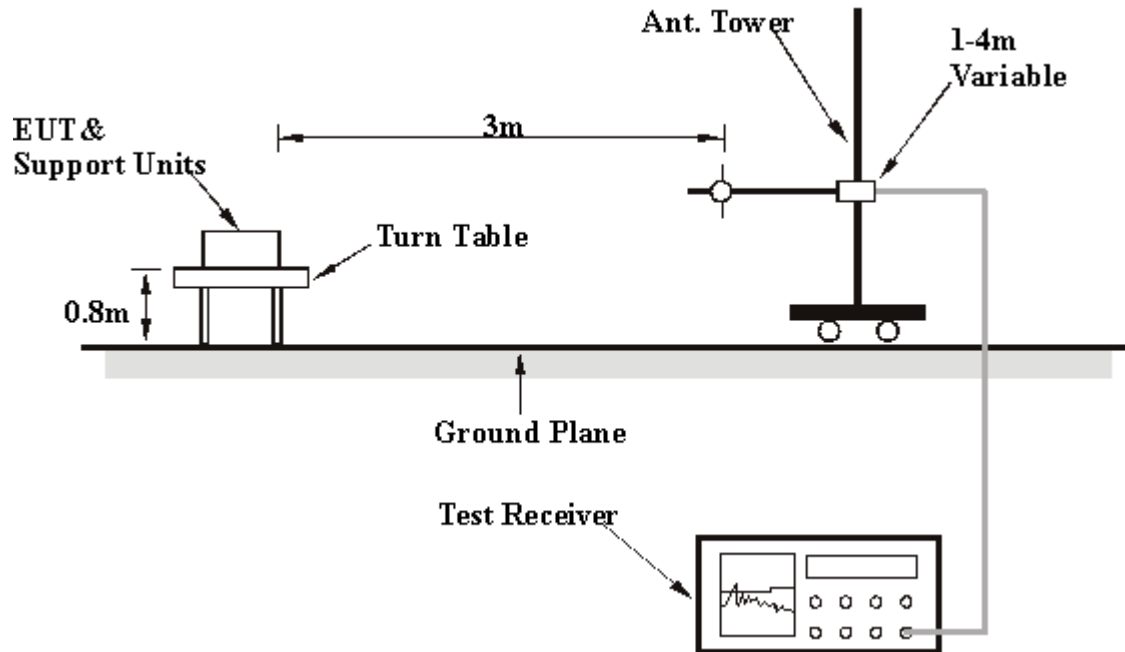

For the actual test configuration, please refer to the related item – Photographs of the Test Configuration.

## 5.2.7 EUT OPERATING CONDITIONS

Same as 4.1.6.



## 5.2.8 TEST RESULTS

|                                 |  |                             |              |
|---------------------------------|--|-----------------------------|--------------|
| <b>EUT</b>                      | Wireless Dual Band Enterprise Access Point | <b>MODEL</b>                | RBT3K-AG     |
| <b>FREQUENCY RANGE</b>          | Below 1000MHz                              | <b>DETECTOR FUNCTION</b>    | Quasi-Peak   |
| <b>ENVIRONMENTAL CONDITIONS</b> | 29 deg. C, 56%RH, 976 hPa                  | <b>INPUT POWER (SYSTEM)</b> | 120Vac, 60Hz |
| <b>TEST MODE</b>                | With Adapter                               | <b>TESTED BY</b>            | Eic Lee      |

**ANTENNA POLARITY & TEST DISTANCE: HORIZONTAL AT 3 M**

| No. | Freq. (MHz) | Emission Level (dBuV/m) | Limit (dBuV/m) | Margin (dB) | Antenna Height (m) | Table Angle (Degree) | Raw Value (dBuV) | Correction Factor (dB/m) |
|-----|-------------|-------------------------|----------------|-------------|--------------------|----------------------|------------------|--------------------------|
| 1   | 45.50       | 26.1 QP                 | 40.00          | -13.90      | 1.25 H             | 331                  | 15.20            | 11.00                    |
| 2   | 125.13      | 28.8 QP                 | 43.50          | -14.70      | 1.15 H             | 337                  | 16.70            | 12.00                    |
| 3   | 220.34      | 22.7 QP                 | 46.00          | -23.30      | 1.52 H             | 324                  | 13.20            | 9.40                     |
| 4   | 250.01      | 30.0 QP                 | 46.00          | -16.00      | 1.44 H             | 341                  | 17.00            | 13.00                    |
| 5   | 264.19      | 30.8 QP                 | 46.00          | -15.20      | 1.48 H             | 241                  | 16.70            | 14.00                    |
| 6   | 351.55      | 36.5 QP                 | 46.00          | -9.50       | 1.17 H             | 29                   | 21.00            | 15.50                    |
| 7   | 375.20      | 30.2 QP                 | 46.00          | -15.80      | 1.28 H             | 0                    | 14.00            | 16.20                    |
| 8   | 395.68      | 36.3 QP                 | 46.00          | -9.70       | 1.00 H             | 212                  | 19.40            | 16.90                    |
| 9   | 479.54      | 30.3 QP                 | 46.00          | -15.70      | 1.22 H             | 13                   | 11.50            | 18.90                    |
| 10  | 499.91      | 32.5 QP                 | 46.00          | -13.50      | 1.06 H             | 114                  | 13.20            | 19.30                    |
| 11  | 527.53      | 42.0 QP                 | 46.00          | -4.00       | 2.00 H             | 194                  | 22.40            | 19.60                    |
| 12  | 625.23      | 32.2 QP                 | 46.00          | -13.80      | 1.34 H             | 56                   | 10.50            | 21.70                    |

**ANTENNA POLARITY & TEST DISTANCE: VERTICAL AT 3 M**

| No. | Freq. (MHz) | Emission Level (dBuV/m) | Limit (dBuV/m) | Margin (dB) | Antenna Height (m) | Table Angle (Degree) | Raw Value (dBuV) | Correction Factor (dB/m) |
|-----|-------------|-------------------------|----------------|-------------|--------------------|----------------------|------------------|--------------------------|
| 1   | 43.25       | 28.2 QP                 | 40.00          | -11.80      | 1.47 V             | 322                  | 16.10            | 12.10                    |
| 2   | 60.58       | 30.7 QP                 | 40.00          | -9.30       | 1.41 V             | 196                  | 25.50            | 5.20                     |
| 3   | 70.25       | 24.0 QP                 | 40.00          | -16.00      | 1.16 V             | 7                    | 18.10            | 5.90                     |
| 4   | 125.02      | 32.1 QP                 | 43.50          | -11.40      | 1.19 V             | 93                   | 20.10            | 12.00                    |
| 5   | 220.04      | 29.9 QP                 | 46.00          | -16.10      | 1.26 V             | 64                   | 20.50            | 9.40                     |
| 6   | 250.29      | 27.9 QP                 | 46.00          | -18.10      | 1.35 V             | 25                   | 14.80            | 13.00                    |
| 7   | 352.33      | 29.9 QP                 | 46.00          | -16.10      | 1.23 V             | 50                   | 14.40            | 15.50                    |
| 8   | 375.01      | 29.0 QP                 | 46.00          | -17.00      | 1.39 V             | 114                  | 12.80            | 16.20                    |
| 9   | 395.56      | 33.3 QP                 | 46.00          | -12.70      | 1.09 V             | 93                   | 16.30            | 16.90                    |
| 10  | 499.62      | 35.2 QP                 | 46.00          | -10.80      | 1.02 V             | 244                  | 15.90            | 19.30                    |
| 11  | 528.34      | 40.3 QP                 | 46.00          | -5.70       | 1.00 V             | 56                   | 20.70            | 19.60                    |

- REMARKS:**
1. Emission level(dBuV/m)=Raw Value(dBuV) + Correction Factor(dB)
  2. Correction Factor(dB/m) = Antenna Factor (dB/m) + Cable Factor (dB)
  3. The other emission levels were very low against the limit.
  4. Margin value = Emission level – Limit value.
  5. The limit value is defined as per 15.247



|                                 |  |                             |              |
|---------------------------------|--|-----------------------------|--------------|
| <b>EUT</b>                      | Wireless Dual Band Enterprise Access Point | <b>MODEL</b>                | RBT3K-AG     |
| <b>FREQUENCY RANGE</b>          | Below 1000MHz                              | <b>DETECTOR FUNCTION</b>    | Quasi-Peak   |
| <b>ENVIRONMENTAL CONDITIONS</b> | 29 deg. C, 56%RH, 976 hPa                  | <b>INPUT POWER (SYSTEM)</b> | 120Vac, 60Hz |
| <b>TEST MODE</b>                | With POE                                   | <b>TESTED BY</b>            | Eic Lee      |

#### ANTENNA POLARITY & TEST DISTANCE: HORIZONTAL AT 3 M

| No. | Freq. (MHz) | Emission Level (dBuV/m) | Limit (dBuV/m) | Margin (dB) | Antenna Height (m) | Table Angle (Degree) | Raw Value (dBuV) | Correction Factor (dB/m) |
|-----|-------------|-------------------------|----------------|-------------|--------------------|----------------------|------------------|--------------------------|
| 1   | 50.69       | 27.5 QP                 | 40.00          | -12.50      | 1.96 H             | 58                   | 19.40            | 8.20                     |
| 2   | 68.29       | 24.0 QP                 | 40.00          | -16.00      | 1.08 H             | 57                   | 18.30            | 5.70                     |
| 3   | 124.59      | 27.6 QP                 | 43.50          | -15.90      | 1.52 H             | 309                  | 15.60            | 12.00                    |
| 4   | 220.00      | 29.4 QP                 | 46.00          | -16.60      | 1.48 H             | 54                   | 20.00            | 9.40                     |
| 5   | 220.11      | 26.3 QP                 | 46.00          | -19.70      | 1.77 H             | 47                   | 16.90            | 9.40                     |
| 6   | 250.03      | 28.0 QP                 | 46.00          | -18.00      | 1.88 H             | 5                    | 15.00            | 13.00                    |
| 7   | 352.01      | 29.8 QP                 | 46.00          | -16.20      | 1.88 H             | 5                    | 14.30            | 15.50                    |
| 8   | 374.98      | 31.9 QP                 | 46.00          | -14.10      | 1.14 H             | 147                  | 15.70            | 16.20                    |
| 9   | 500.12      | 34.3 QP                 | 46.00          | -11.70      | 1.18 H             | 160                  | 15.00            | 19.30                    |
| 10  | 527.68      | 37.2 QP                 | 46.00          | -8.80       | 1.58 H             | 98                   | 17.60            | 19.60                    |

#### ANTENNA POLARITY & TEST DISTANCE: VERTICAL AT 3 M

| No. | Freq. (MHz) | Emission Level (dBuV/m) | Limit (dBuV/m) | Margin (dB) | Antenna Height (m) | Table Angle (Degree) | Raw Value (dBuV) | Correction Factor (dB/m) |
|-----|-------------|-------------------------|----------------|-------------|--------------------|----------------------|------------------|--------------------------|
| 1   | 51.02       | 31.3 QP                 | 40.00          | -8.70       | 1.58 V             | 54                   | 23.20            | 8.00                     |
| 2   | 55.89       | 30.1 QP                 | 40.00          | -9.90       | 1.08 V             | 68                   | 23.70            | 6.40                     |
| 3   | 69.03       | 36.7 QP                 | 40.00          | -3.30       | 1.68 V             | 199                  | 30.90            | 5.80                     |
| 4   | 72.00       | 31.5 QP                 | 40.00          | -8.50       | 1.02 V             | 96                   | 25.20            | 6.30                     |
| 5   | 124.97      | 27.3 QP                 | 43.50          | -16.20      | 1.09 V             | 269                  | 15.30            | 12.00                    |
| 6   | 250.00      | 26.2 QP                 | 46.00          | -19.80      | 1.47 V             | 54                   | 13.20            | 13.00                    |
| 7   | 264.02      | 29.4 QP                 | 46.00          | -16.60      | 1.09 V             | 69                   | 15.30            | 14.10                    |
| 8   | 374.36      | 32.1 QP                 | 46.00          | -13.90      | 1.78 V             | 7                    | 15.90            | 16.20                    |
| 9   | 396.21      | 32.0 QP                 | 46.00          | -14.00      | 1.00 V             | 356                  | 15.00            | 17.00                    |
| 10  | 500.02      | 34.3 QP                 | 46.00          | -11.70      | 1.38 V             | 68                   | 15.00            | 19.30                    |
| 11  | 527.89      | 40.6 QP                 | 46.00          | -5.40       | 1.08 V             | 354                  | 21.00            | 19.60                    |
| 12  | 625.32      | 33.3 QP                 | 46.00          | -12.70      | 1.58 V             | 55                   | 11.60            | 21.70                    |

- REMARKS:**
1. Emission level(dBuV/m)=Raw Value(dBuV) + Correction Factor(dB)
  2. Correction Factor(dB/m) = Antenna Factor (dB/m) + Cable Factor (dB)
  3. The other emission levels were very low against the limit.
  4. Margin value = Emission level – Limit value.
  5. The limit value is defined as per 15.247



### 5.2.9 TEST RESULTS STANDARD SECTION 15.407

|                                 |  |                             |                          |
|---------------------------------|--|-----------------------------|--------------------------|
| <b>EUT</b>                      | Wireless Dual Band Enterprise Access Point | <b>MODEL</b>                | RBT3K-AG                 |
| <b>MODE</b>                     | Normal Mode                                | <b>CHANNEL</b>              | 1                        |
| <b>FREQUENCY RANGE</b>          | 1000MHz~25000MHz                           | <b>DETECTOR FUNCTION</b>    | Peak(PK)<br>Average (AV) |
| <b>ENVIRONMENTAL CONDITIONS</b> | 28 deg. C, 56%RH,<br>974 hPa               | <b>INPUT POWER (SYSTEM)</b> | 120Vac, 60Hz             |
| <b>TESTED BY</b>                | Eric Lee                                   |                             |                          |

#### ANTENNA POLARITY & TEST DISTANCE: HORIZONTAL AT 3 M

| No. | Freq. (MHz) | Emission Level (dBuV/m) | Limit (dBuV/m) | Margin (dB) | Antenna Height (m) | Table Angle (Degree) | Raw Value (dBuV) | Correction Factor (dB/m) |
|-----|-------------|-------------------------|----------------|-------------|--------------------|----------------------|------------------|--------------------------|
| 1   | #5088.00    | 54.2 PK                 | 74.00          | -19.80      | 1.46 H             | 329                  | 17.10            | 37.00                    |
| 1   | #5088.00    | 46.2 AV                 | 54.00          | -7.80       | 1.46 H             | 329                  | 9.20             | 37.00                    |
| 2   | #5120.00    | 55.0 PK                 | 74.00          | -19.00      | 1.08 H             | 326                  | 18.00            | 37.00                    |
| 2   | #5120.00    | 46.6 AV                 | 54.00          | -7.40       | 1.08 H             | 326                  | 9.60             | 37.00                    |
| 3   | #5150.00    | 54.6 PK                 | 74.00          | -19.40      | 1.40 H             | 208                  | 17.60            | 37.00                    |
| 3   | #5150.00    | 44.6 AV                 | 54.00          | -9.40       | 1.40 H             | 208                  | 7.60             | 37.00                    |
| 4   | *5180.00    | 95.3 PK                 |                |             | 1.48 H             | 69                   | 58.30            | 37.00                    |
| 4   | *5180.00    | 87.1 AV                 |                |             | 1.48 H             | 69                   | 50.10            | 37.00                    |
| 5   | #5440.00    | 52.1 PK                 | 74.00          | -21.90      | 1.37 H             | 151                  | 15.10            | 37.00                    |
| 5   | #5440.00    | 44.9 AV                 | 54.00          | -9.10       | 1.37 H             | 151                  | 7.90             | 37.00                    |
| 6   | 10360.00    | 49.7 PK                 | 68.30          | -18.60      | 1.07 H             | 46                   | 5.00             | 44.70                    |

#### ANTENNA POLARITY & TEST DISTANCE: VERTICAL AT 3 M

| No. | Freq. (MHz) | Emission Level (dBuV/m) | Limit (dBuV/m) | Margin (dB) | Antenna Height (m) | Table Angle (Degree) | Raw Value (dBuV) | Correction Factor (dB/m) |
|-----|-------------|-------------------------|----------------|-------------|--------------------|----------------------|------------------|--------------------------|
| 1   | #5088.00    | 63.2 PK                 | 74.00          | -10.80      | 1.01 V             | 43                   | 26.20            | 37.00                    |
| 1   | #5088.00    | 51.0 AV                 | 54.00          | -3.00       | 1.01 V             | 43                   | 14.00            | 37.00                    |
| 2   | #5120.00    | 58.3 PK                 | 74.00          | -15.70      | 1.85 V             | 65                   | 21.30            | 37.00                    |
| 2   | #5120.00    | 51.6 AV                 | 54.00          | -2.40       | 1.85 V             | 65                   | 14.60            | 37.00                    |
| 3   | #5150.00    | 59.6 PK                 | 74.00          | -14.40      | 1.39 V             | 66                   | 22.60            | 37.00                    |
| 3   | #5150.00    | 50.3 AV                 | 54.00          | -3.70       | 1.39 V             | 66                   | 13.30            | 37.00                    |
| 4   | *5180.00    | 103.3 PK                |                |             | 1.25 V             | 54                   | 66.20            | 37.00                    |
| 4   | *5180.00    | 95.7 AV                 |                |             | 1.25 V             | 54                   | 58.60            | 37.00                    |
| 5   | #5440.00    | 60.3 PK                 | 74.00          | -13.70      | 1.36 V             | 332                  | 23.30            | 37.00                    |
| 5   | #5440.00    | 52.2 AV                 | 54.00          | -1.80       | 1.36 V             | 332                  | 15.20            | 37.00                    |
| 6   | 10360.00    | 53.9 PK                 | 68.30          | -14.40      | 1.35 V             | 222                  | 9.20             | 44.70                    |

#### NOTE:

1. Emission level = Raw value - Correction Factor
2. Correction Factor = Pre-Amp. Factor - Ant. Factor - Cable loss  
(Pre-Amp. Factor = 0, when a Pre-Amplifier is not used for the test.)
3. Margin value = Emission level - Limit value
4. The other emission levels were very low against the limit.
5. "\*" : Fundamental frequency
6. "# " : The radiated frequency falling in the restricted band.



## STANDARD SECTION 15.407

|                                 |  |                             |                          |
|---------------------------------|--|-----------------------------|--------------------------|
| <b>EUT</b>                      | Wireless Dual Band Enterprise Access Point | <b>MODEL</b>                | RBT3K-AG                 |
| <b>MODE</b>                     | Normal Mode                                | <b>CHANNEL</b>              | 4                        |
| <b>FREQUENCY RANGE</b>          | 1000MHz~40000MHz                           | <b>DETECTOR FUNCTION</b>    | Peak(PK)<br>Average (AV) |
| <b>ENVIRONMENTAL CONDITIONS</b> | 28 deg. C, 56%RH,<br>974 hPa               | <b>INPUT POWER (SYSTEM)</b> | 120Vac, 60Hz             |
| <b>TESTED BY</b>                | Eric Lee                                   |                             |                          |

**ANTENNA POLARITY & TEST DISTANCE: HORIZONTAL AT 3 M**

| No. | Freq. (MHz) | Emission Level (dBuV/m) | Limit (dBuV/m) | Margin (dB) | Antenna Height (m) | Table Angle (Degree) | Raw Value (dBuV) | Correction Factor (dB/m) |
|-----|-------------|-------------------------|----------------|-------------|--------------------|----------------------|------------------|--------------------------|
| 1   | #5088.00    | 51.0 PK                 | 74.00          | -23.00      | 1.21 H             | 5                    | 13.90            | 37.00                    |
| 1   | #5088.00    | 43.0 AV                 | 54.00          | -11.00      | 1.21 H             | 5                    | 6.00             | 37.00                    |
| 2   | #5150.00    | 50.6 PK                 | 74.00          | -23.40      | 1.30 H             | 65                   | 13.50            | 37.00                    |
| 3   | *5240.00    | 96.4 PK                 |                |             | 1.33 H             | 200                  | 59.40            | 37.00                    |
| 3   | *5240.00    | 87.9 AV                 |                |             | 1.33 H             | 200                  | 50.90            | 37.00                    |
| 4   | #5440.00    | 53.3 PK                 | 74.00          | -20.70      | 1.05 H             | 22                   | 16.20            | 37.00                    |
| 4   | #5440.00    | 45.1 AV                 | 54.00          | -8.90       | 1.05 H             | 22                   | 8.10             | 37.00                    |
| 5   | 10480.00    | 49.9 PK                 | 68.30          | -18.40      | 1.35 H             | 69                   | 4.90             | 45.00                    |

**ANTENNA POLARITY & TEST DISTANCE: VERTICAL AT 3 M**

| No. | Freq. (MHz) | Emission Level (dBuV/m) | Limit (dBuV/m) | Margin (dB) | Antenna Height (m) | Table Angle (Degree) | Raw Value (dBuV) | Correction Factor (dB/m) |
|-----|-------------|-------------------------|----------------|-------------|--------------------|----------------------|------------------|--------------------------|
| 1   | #5088.00    | 57.2 PK                 | 74.00          | -16.80      | 1.07 V             | 57                   | 20.10            | 37.00                    |
| 1   | #5088.00    | 47.7 AV                 | 54.00          | -6.30       | 1.07 V             | 57                   | 10.60            | 37.00                    |
| 2   | #5150.00    | 55.2 PK                 | 74.00          | -18.80      | 1.36 V             | 307                  | 18.20            | 37.00                    |
| 2   | #5150.00    | 47.3 AV                 | 54.00          | -6.70       | 1.36 V             | 307                  | 10.20            | 37.00                    |
| 3   | *5240.00    | 102.9 PK                |                |             | 1.35 V             | 68                   | 65.90            | 37.00                    |
| 3   | *5240.00    | 96.0 AV                 |                |             | 1.35 V             | 68                   | 59.00            | 37.00                    |
| 4   | #5440.00    | 57.6 PK                 | 74.00          | -16.40      | 1.32 V             | 256                  | 20.60            | 37.00                    |
| 4   | #5440.00    | 49.4 AV                 | 54.00          | -4.60       | 1.32 V             | 256                  | 12.40            | 37.00                    |
| 5   | 10480.00    | 54.6 PK                 | 68.30          | -13.70      | 1.20 V             | 249                  | 9.70             | 45.00                    |

**NOTE:**

- Emission level = Raw value - Correction Factor
- Correction Factor = Pre-Amp. Factor - Ant. Factor - Cable loss  
(Pre-Amp. Factor = 0, when a Pre-Amplifier is not used for the test.)
- Margin value = Emission level - Limit value
- The other emission levels were very low against the limit.
- "\*": Fundamental frequency
- "#": The radiated frequency falling in the restricted band.



STANDARD SECTION 15.407

|                                 |  |                             |                           |
|---------------------------------|--|-----------------------------|---------------------------|
| <b>EUT</b>                      | Wireless Dual Band Enterprise Access Point | <b>MODEL</b>                | RBT3K-AG                  |
| <b>MODE</b>                     | Normal Mode                                | <b>CHANNEL</b>              | 5                         |
| <b>FREQUENCY RANGE</b>          | 1000MHz~40000MHz                           | <b>DETECTOR FUNCTION</b>    | Peak (PK)<br>Average (AV) |
| <b>ENVIRONMENTAL CONDITIONS</b> | 28 deg. C, 56%RH,<br>974 hPa               | <b>INPUT POWER (SYSTEM)</b> | 120Vac, 60Hz              |
| <b>TESTED BY</b>                | Eric Lee                                   |                             |                           |

**ANTENNA POLARITY & TEST DISTANCE: HORIZONTAL AT 3 M**

| No. | Freq. (MHz) | Emission Level (dBuV/m) | Limit (dBuV/m) | Margin (dB) | Antenna Height (m) | Table Angle (Degree) | Raw Value (dBuV) | Correction Factor (dB/m) |
|-----|-------------|-------------------------|----------------|-------------|--------------------|----------------------|------------------|--------------------------|
| 1   | #5056.00    | 44.60 PK                | 74.00          | -29.40      | 1.52 H             | 32                   | 7.60             | 37.00                    |
| 2   | #5120.00    | 51.20 PK                | 74.00          | -22.80      | 1.21 H             | 54                   | 14.20            | 37.00                    |
| 2   | #5120.00    | 44.70 AV                | 54.00          | -9.30       | 1.21 H             | 54                   | 7.60             | 37.00                    |
| 3   | *5260.00    | 102.00 PK               |                |             | 1.36 H             | 241                  | 65.00            | 37.00                    |
| 3   | *5260.00    | 92.70 AV                |                |             | 1.36 H             | 241                  | 55.60            | 37.00                    |
| 4   | #5376.00    | 52.00 PK                | 74.00          | -22.00      | 1.11 H             | 2                    | 15.00            | 37.00                    |
| 4   | #5376.00    | 45.70 AV                | 54.00          | -8.30       | 1.11 H             | 2                    | 8.70             | 37.00                    |
| 5   | #5440.00    | 51.00 PK                | 74.00          | -23.00      | 1.45 H             | 21                   | 14.00            | 37.00                    |
| 5   | #5440.00    | 45.70 AV                | 54.00          | -8.30       | 1.45 H             | 21                   | 8.60             | 37.00                    |
| 6   | 10520.00    | 49.00 PK                | 68.30          | -19.30      | 1.02 H             | 241                  | 3.80             | 45.20                    |

**ANTENNA POLARITY & TEST DISTANCE: VERTICAL AT 3 M**

| No. | Freq. (MHz) | Emission Level (dBuV/m) | Limit (dBuV/m) | Margin (dB) | Antenna Height (m) | Table Angle (Degree) | Raw Value (dBuV) | Correction Factor (dB/m) |
|-----|-------------|-------------------------|----------------|-------------|--------------------|----------------------|------------------|--------------------------|
| 1   | #5056.00    | 52.90 PK                | 74.00          | -21.10      | 1.17 V             | 111                  | 15.80            | 37.00                    |
| 1   | #5056.00    | 48.90 AV                | 54.00          | -5.10       | 1.17 V             | 111                  | 11.80            | 37.00                    |
| 2   | #5120.00    | 58.70 PK                | 74.00          | -15.30      | 1.19 V             | 12                   | 21.60            | 37.00                    |
| 2   | #5120.00    | 52.20 AV                | 54.00          | -1.80       | 1.19 V             | 12                   | 15.20            | 37.00                    |
| 3   | *5260.00    | 108.20 PK               |                |             | 1.09 V             | 359                  | 71.20            | 37.00                    |
| 3   | *5260.00    | 99.90 AV                |                |             | 1.09 V             | 359                  | 62.90            | 37.00                    |
| 4   | #5376.00    | 59.10 PK                | 74.00          | -14.90      | 1.18 V             | 99                   | 22.10            | 37.00                    |
| 4   | #5376.00    | 53.00 AV                | 54.00          | -1.00       | 1.18 V             | 99                   | 16.00            | 37.00                    |
| 5   | #5440.00    | 59.10 PK                | 74.00          | -14.90      | 1.15 V             | 122                  | 22.00            | 37.00                    |
| 5   | #5440.00    | 52.80 AV                | 54.00          | -1.20       | 1.15 V             | 122                  | 15.80            | 37.00                    |
| 6   | 10520.00    | 53.80 PK                | 68.30          | -14.50      | 1.19 V             | 160                  | 8.60             | 45.20                    |

**NOTE:**

1. Emission level = Raw value - Correction Factor
2. Correction Factor = Pre-Amp. Factor - Ant. Factor - Cable loss  
(Pre-Amp. Factor = 0, when a Pre-Amplifier is not used for the test.)
3. Margin value = Emission level - Limit value
4. The other emission levels were very low against the limit.
5. "\*" : Fundamental frequency
6. "#" : The radiated frequency falling in the restricted band.



## STANDARD SECTION 15.407

|                                 |  |                             |                          |
|---------------------------------|--|-----------------------------|--------------------------|
| <b>EUT</b>                      | Wireless Dual Band Enterprise Access Point | <b>MODEL</b>                | RBT3K-AG                 |
| <b>MODE</b>                     | Normal Mode                                | <b>CHANNEL</b>              | 8                        |
| <b>FREQUENCY RANGE</b>          | 1000MHz~40000MHz                           | <b>DETECTOR FUNCTION</b>    | Peak(PK)<br>Average (AV) |
| <b>ENVIRONMENTAL CONDITIONS</b> | 28 deg. C, 56%RH,<br>974 hPa               | <b>INPUT POWER (SYSTEM)</b> | 120Vac, 60Hz             |
| <b>TESTED BY</b>                | Eric Lee                                   |                             |                          |

**ANTENNA POLARITY & TEST DISTANCE: HORIZONTAL AT 3 M**

| No. | Freq. (MHz) | Emission Level (dBuV/m) | Limit (dBuV/m) | Margin (dB) | Antenna Height (m) | Table Angle (Degree) | Raw Value (dBuV) | Correction Factor (dB/m) |
|-----|-------------|-------------------------|----------------|-------------|--------------------|----------------------|------------------|--------------------------|
| 1   | #5120.00    | 50.7 PK                 | 74.00          | -23.30      | 1.76 H             | 64                   | 13.70            | 37.00                    |
| 2   | *5320.00    | 95.1 PK                 |                |             | 1.06 H             | 326                  | 58.10            | 37.00                    |
| 2   | *5320.00    | 88.0 AV                 |                |             | 1.06 H             | 326                  | 51.00            | 37.00                    |
| 3   | #5350.00    | 51.5 PK                 | 74.00          | -22.50      | 1.07 H             | 168                  | 14.50            | 37.00                    |
| 3   | #5350.00    | 45.9 AV                 | 54.00          | -8.10       | 1.07 H             | 168                  | 8.90             | 37.00                    |
| 4   | #5408.00    | 53.7 PK                 | 74.00          | -20.30      | 1.53 H             | 354                  | 16.70            | 37.00                    |
| 4   | #5408.00    | 48.0 AV                 | 54.00          | -6.00       | 1.53 H             | 354                  | 11.00            | 37.00                    |
| 5   | #10640.00   | 53.9 PK                 | 74.00          | -20.10      | 1.36 H             | 199                  | 7.60             | 46.30                    |
| 5   | #10640.00   | 43.2 AV                 | 54.00          | -10.80      | 1.36 H             | 199                  | -3.10            | 37.00                    |

**ANTENNA POLARITY & TEST DISTANCE: VERTICAL AT 3 M**

| No. | Freq. (MHz) | Emission Level (dBuV/m) | Limit (dBuV/m) | Margin (dB) | Antenna Height (m) | Table Angle (Degree) | Raw Value (dBuV) | Correction Factor (dB/m) |
|-----|-------------|-------------------------|----------------|-------------|--------------------|----------------------|------------------|--------------------------|
| 1   | #5120.00    | 55.3 PK                 | 74.00          | -18.70      | 1.33 V             | 201                  | 18.30            | 37.00                    |
| 1   | #5120.00    | 46.1 AV                 | 54.00          | -7.90       | 1.33 V             | 201                  | 9.10             | 37.00                    |
| 2   | *5320.00    | 102.3 PK                |                |             | 1.05 V             | 326                  | 65.30            | 37.00                    |
| 2   | *5320.00    | 94.0 AV                 |                |             | 1.05 V             | 326                  | 57.00            | 37.00                    |
| 3   | #5350.00    | 60.8 PK                 | 74.00          | -13.20      | 1.09 V             | 357                  | 23.80            | 37.00                    |
| 3   | #5350.00    | 51.9 AV                 | 54.00          | -2.10       | 1.09 V             | 357                  | 14.90            | 37.00                    |
| 4   | #5408.00    | 62.4 PK                 | 74.00          | -11.60      | 1.58 V             | 52                   | 25.40            | 37.00                    |
| 4   | #5408.00    | 53.0 AV                 | 54.00          | -1.00       | 1.58 V             | 52                   | 16.00            | 37.00                    |
| 5   | #10640.00   | 58.1 PK                 | 74.00          | -15.90      | 1.22 V             | 5                    | 11.90            | 46.30                    |
| 5   | #10640.00   | 46.4 AV                 | 54.00          | -7.60       | 1.22 V             | 5                    | 0.10             | 46.30                    |

**NOTE:**

1. Emission level = Raw value - Correction Factor
2. Correction Factor = Pre-Amp. Factor - Ant. Factor - Cable loss  
(Pre-Amp. Factor = 0, when a Pre-Amplifier is not used for the test.)
3. Margin value = Emission level - Limit value
4. The other emission levels were very low against the limit.
5. "\*" : Fundamental frequency
6. "#" : The radiated frequency falling in the restricted band.



STANDARD SECTION 15.247

|                                 |  |                             |                          |
|---------------------------------|--|-----------------------------|--------------------------|
| <b>EUT</b>                      | Wireless Dual Band Enterprise Access Point | <b>MODEL</b>                | RBT3K-AG                 |
| <b>MODE</b>                     | Normal Mode                                | <b>CHANNEL</b>              | 9                        |
| <b>FREQUENCY RANGE</b>          | 1000MHz~40000MHz                           | <b>DETECTOR FUNCTION</b>    | Peak(PK)<br>Average (AV) |
| <b>ENVIRONMENTAL CONDITIONS</b> | 26 deg. C, 67%RH,<br>974 hPa               | <b>INPUT POWER (SYSTEM)</b> | 120Vac, 60Hz             |
| <b>TESTED BY</b>                | Eric Lee                                   |                             |                          |

**ANTENNA POLARITY & TEST DISTANCE: HORIZONTAL AT 3 M**

| No. | Freq. (MHz) | Emission Level (dBuV/m) | Limit (dBuV/m) | Margin (dB) | Antenna Height (m) | Table Angle (Degree) | Raw Value (dBuV) | Correction Factor (dB/m) |
|-----|-------------|-------------------------|----------------|-------------|--------------------|----------------------|------------------|--------------------------|
| 1   | #5120.00    | 48.70 PK                | 74.00          | -25.30      | 1.36 H             | 65                   | 11.70            | 37.00                    |
| 2   | #5408.00    | 51.00 PK                | 74.00          | -23.00      | 1.04 H             | 78                   | 13.90            | 37.00                    |
| 2   | #5408.00    | 43.10 AV                | 54.00          | -10.90      | 1.04 H             | 78                   | 6.10             | 37.00                    |
| 3   | #5440.00    | 54.40 PK                | 74.00          | -19.60      | 1.36 H             | 65                   | 17.30            | 37.00                    |
| 3   | #5440.00    | 46.50 AV                | 54.00          | -7.50       | 1.36 H             | 65                   | 9.50             | 37.00                    |
| 4   | *5745.00    | 102.80 PK               |                |             | 1.05 H             | 65                   | 65.20            | 37.60                    |
| 4   | *5745.00    | 94.50 AV                |                |             | 1.05 H             | 65                   | 57.00            | 37.60                    |
| 5   | #11490.00   | 51.60 PK                | 74.00          | -22.40      | 1.63 H             | 98                   | 0.30             | 51.30                    |
| 5   | #11490.00   | 43.80 AV                | 54.00          | -10.20      | 1.63 H             | 98                   | -7.50            | 51.30                    |

**ANTENNA POLARITY & TEST DISTANCE: VERTICAL AT 3 M**

| No.      | Freq. (MHz)     | Emission Level (dBuV/m) | Limit (dBuV/m) | Margin (dB)  | Antenna Height (m) | Table Angle (Degree) | Raw Value (dBuV) | Correction Factor (dB/m) |
|----------|-----------------|-------------------------|----------------|--------------|--------------------|----------------------|------------------|--------------------------|
| 1        | #5120.00        | 54.20 PK                | 74.00          | -19.80       | 1.02 V             | 312                  | 17.20            | 37.00                    |
| 1        | #5120.00        | 48.80 AV                | 54.00          | -5.20        | 1.02 V             | 312                  | 11.70            | 37.00                    |
| 2        | #5408.00        | 58.90 PK                | 74.00          | -15.10       | 1.02 V             | 11                   | 21.90            | 37.00                    |
| 2        | #5408.00        | 50.80 AV                | 54.00          | -3.20        | 1.02 V             | 11                   | 13.80            | 37.00                    |
| 3        | #5440.00        | 61.70 PK                | 74.00          | -12.30       | 1.02 V             | 50                   | 24.70            | 37.00                    |
| <b>3</b> | <b>#5440.00</b> | <b>52.70 AV</b>         | <b>54.00</b>   | <b>-1.30</b> | <b>1.02 V</b>      | <b>50</b>            | <b>15.70</b>     | <b>37.00</b>             |
| 4        | *5745.00        | 109.70 PK               |                |              | 1.06 V             | 241                  | 72.10            | 37.60                    |
| 4        | *5745.00        | 101.70 AV               |                |              | 1.06 V             | 241                  | 64.10            | 37.60                    |
| 5        | #11490.00       | 54.90 PK                | 74.00          | -19.10       | 1.55 V             | 24                   | 3.50             | 51.30                    |
| 5        | #11490.00       | 46.90 AV                | 54.00          | -7.10        | 1.55 V             | 24                   | -4.40            | 51.30                    |

**NOTE:**

1. Emission level = Raw value - Correction Factor
2. Correction Factor = Pre-Amp. Factor - Ant. Factor - Cable loss  
(Pre-Amp. Factor = 0, when a Pre-Amplifier is not used for the test.)
3. Margin value = Emission level - Limit value
4. The other emission levels were very low against the limit.
5. “\*”: Fundamental frequency
6. “# “ : The radiated frequency falling in the restricted band.





## STANDARD SECTION 15.247

|                                 |  |                             |                          |
|---------------------------------|--|-----------------------------|--------------------------|
| <b>EUT</b>                      | Wireless Dual Band Enterprise Access Point | <b>MODEL</b>                | RBT3K-AG                 |
| <b>MODE</b>                     | Normal Mode                                | <b>CHANNEL</b>              | 11                       |
| <b>FREQUENCY RANGE</b>          | 1000MHz~40000MHz                           | <b>DETECTOR FUNCTION</b>    | Peak(PK)<br>Average (AV) |
| <b>ENVIRONMENTAL CONDITIONS</b> | 26 deg. C, 67%RH,<br>974 hPa               | <b>INPUT POWER (SYSTEM)</b> | 120Vac, 60Hz             |
| <b>TESTED BY</b>                | Eric Lee                                   |                             |                          |

**ANTENNA POLARITY & TEST DISTANCE: HORIZONTAL AT 3 M**

| No. | Freq. (MHz) | Emission Level (dBuV/m) | Limit (dBuV/m) | Margin (dB) | Antenna Height (m) | Table Angle (Degree) | Raw Value (dBuV) | Correction Factor (dB/m) |
|-----|-------------|-------------------------|----------------|-------------|--------------------|----------------------|------------------|--------------------------|
| 1   | #5120.00    | 49.60 PK                | 74.00          | -24.40      | 1.01 H             | 25                   | 12.60            | 37.00                    |
| 2   | #5376.00    | 50.60 PK                | 74.00          | -23.40      | 1.55 H             | 62                   | 13.50            | 37.00                    |
| 3   | #5440.00    | 53.90 PK                | 74.00          | -20.10      | 1.00 H             | 1                    | 16.90            | 37.00                    |
| 3   | #5440.00    | 45.90 AV                | 54.00          | -8.10       | 1.00 H             | 1                    | 8.90             | 37.00                    |
| 4   | *5785.00    | 94.50 PK                |                |             | 1.63 H             | 326                  | 56.90            | 37.60                    |
| 4   | *5785.00    | 94.80 AV                |                |             | 1.63 H             | 326                  | 57.20            | 37.60                    |
| 5   | #11570.00   | 50.70 PK                | 74.00          | -23.30      | 1.22 H             | 63                   | -0.40            | 51.10                    |

**ANTENNA POLARITY & TEST DISTANCE: VERTICAL AT 3 M**

| No. | Freq. (MHz) | Emission Level (dBuV/m) | Limit (dBuV/m) | Margin (dB) | Antenna Height (m) | Table Angle (Degree) | Raw Value (dBuV) | Correction Factor (dB/m) |
|-----|-------------|-------------------------|----------------|-------------|--------------------|----------------------|------------------|--------------------------|
| 1   | #5120.00    | 55.60 PK                | 74.00          | -18.40      | 1.02 V             | 33                   | 18.50            | 37.00                    |
| 1   | #5120.00    | 48.70 AV                | 54.00          | -5.30       | 1.02 V             | 33                   | 11.60            | 37.00                    |
| 2   | #5376.00    | 57.90 PK                | 74.00          | -16.10      | 1.20 V             | 89                   | 20.90            | 37.00                    |
| 2   | #5376.00    | 50.10 AV                | 54.00          | -3.90       | 1.20 V             | 89                   | 13.10            | 37.00                    |
| 3   | #5440.00    | 58.70 PK                | 74.00          | -15.30      | 1.45 V             | 41                   | 21.70            | 37.00                    |
| 3   | #5440.00    | 51.30 AV                | 54.00          | -2.70       | 1.45 V             | 41                   | 14.30            | 37.00                    |
| 4   | *5785.00    | 109.70 PK               |                |             | 1.52 V             | 24                   | 72.10            | 37.60                    |
| 4   | *5785.00    | 101.80 AV               |                |             | 1.52 V             | 24                   | 64.20            | 37.60                    |
| 5   | #11570.00   | 55.30 PK                | 74.00          | -18.70      | 1.56 V             | 326                  | 4.20             | 51.10                    |
| 5   | #11570.00   | 46.60 AV                | 54.00          | -7.40       | 1.56 V             | 326                  | -4.50            | 51.10                    |

**NOTE:**

1. Emission level = Raw value - Correction Factor
2. Correction Factor = Pre-Amp. Factor - Ant. Factor - Cable loss  
(Pre-Amp. Factor = 0, when a Pre-Amplifier is not used for the test.)
3. Margin value = Emission level - Limit value
4. The other emission levels were very low against the limit.
5. "\*": Fundamental frequency
6. "#": The radiated frequency falling in the restricted band.



## STANDARD SECTION 15.247

|                                 |  |                             |                          |
|---------------------------------|--|-----------------------------|--------------------------|
| <b>EUT</b>                      | Wireless Dual Band Enterprise Access Point | <b>MODEL</b>                | RBT3K-AG                 |
| <b>MODE</b>                     | Normal Mode                                | <b>CHANNEL</b>              | 13                       |
| <b>FREQUENCY RANGE</b>          | 1000MHz~40000MHz                           | <b>DETECTOR FUNCTION</b>    | Peak(PK)<br>Average (AV) |
| <b>ENVIRONMENTAL CONDITIONS</b> | 26 deg. C, 67%RH,<br>974 hPa               | <b>INPUT POWER (SYSTEM)</b> | 120Vac, 60Hz             |
| <b>TESTED BY</b>                | Eric Lee                                   |                             |                          |

**ANTENNA POLARITY & TEST DISTANCE: HORIZONTAL AT 3 M**

| No. | Freq. (MHz) | Emission Level (dBuV/m) | Limit (dBuV/m) | Margin (dB) | Antenna Height (m) | Table Angle (Degree) | Raw Value (dBuV) | Correction Factor (dB/m) |
|-----|-------------|-------------------------|----------------|-------------|--------------------|----------------------|------------------|--------------------------|
| 1   | #5120.00    | 49.20 PK                | 74.00          | -24.80      | 1.25 H             | 45                   | 12.20            | 37.00                    |
| 2   | #5376.00    | 52.60 PK                | 74.00          | -21.40      | 1.65 H             | 45                   | 15.60            | 37.00                    |
| 2   | #5376.00    | 44.00 AV                | 54.00          | -10.00      | 1.65 H             | 45                   | 7.00             | 37.00                    |
| 3   | #5440.00    | 51.00 PK                | 74.00          | -23.00      | 1.02 H             | 123                  | 14.00            | 37.00                    |
| 3   | #5440.00    | 43.90 AV                | 54.00          | -10.10      | 1.02 H             | 123                  | 6.90             | 37.00                    |
| 4   | *5825.00    | 101.90 PK               |                |             | 1.22 H             | 36                   | 64.20            | 37.70                    |
| 4   | *5825.00    | 95.70 AV                |                |             | 1.22 H             | 36                   | 58.00            | 37.70                    |
| 5   | #11650.00   | 51.10 PK                | 74.00          | -22.90      | 1.86 H             | 32                   | 0.20             | 50.80                    |
| 5   | #11650.00   | 44.00 AV                | 54.00          | -10.00      | 1.86 H             | 32                   | -6.90            | 50.80                    |

**ANTENNA POLARITY & TEST DISTANCE: VERTICAL AT 3 M**

| No. | Freq. (MHz) | Emission Level (dBuV/m) | Limit (dBuV/m) | Margin (dB) | Antenna Height (m) | Table Angle (Degree) | Raw Value (dBuV) | Correction Factor (dB/m) |
|-----|-------------|-------------------------|----------------|-------------|--------------------|----------------------|------------------|--------------------------|
| 1   | #5120.00    | 53.70 PK                | 74.00          | -20.30      | 1.25 V             | 41                   | 16.60            | 37.00                    |
| 1   | #5120.00    | 46.80 AV                | 54.00          | -7.20       | 1.25 V             | 41                   | 9.70             | 37.00                    |
| 2   | #5376.00    | 56.20 PK                | 74.00          | -17.80      | 1.19 V             | 217                  | 19.10            | 37.00                    |
| 2   | #5376.00    | 49.10 AV                | 54.00          | -4.90       | 1.19 V             | 217                  | 12.10            | 37.00                    |
| 3   | #5440.00    | 57.40 PK                | 74.00          | -16.60      | 1.56 V             | 226                  | 20.30            | 37.00                    |
| 3   | #5440.00    | 50.00 AV                | 54.00          | -4.00       | 1.56 V             | 226                  | 12.90            | 37.00                    |
| 4   | *5825.00    | 111.40 PK               |                |             | 1.06 V             | 98                   | 73.70            | 37.70                    |
| 4   | *5825.00    | 102.40 AV               |                |             | 1.06 V             | 98                   | 64.60            | 37.70                    |
| 5   | #11650.00   | 56.10 PK                | 74.00          | -17.90      | 1.75 V             | 41                   | 5.30             | 50.80                    |
| 5   | #11650.00   | 47.20 AV                | 54.00          | -6.80       | 1.75 V             | 41                   | -3.60            | 50.80                    |

**NOTE:**

1. Emission level = Raw value - Correction Factor
2. Correction Factor = Pre-Amp. Factor - Ant. Factor - Cable loss  
(Pre-Amp. Factor = 0, when a Pre-Amplifier is not used for the test.)
3. Margin value = Emission level - Limit value
4. The other emission levels were very low against the limit.
5. "\*": Fundamental frequency
6. "#": The radiated frequency falling in the restricted band.



## STANDARD SECTION 15.407

|                                 |  |                             |                           |
|---------------------------------|--|-----------------------------|---------------------------|
| <b>EUT</b>                      | Wireless Dual Band Enterprise Access Point | <b>MODEL</b>                | RBT3K-AG                  |
| <b>MODE</b>                     | Turbo Mode                                 | <b>CHANNEL</b>              | 1                         |
| <b>FREQUENCY RANGE</b>          | 1000MHz~40000MHz                           | <b>DETECTOR FUNCTION</b>    | Peak (PK)<br>Average (AV) |
| <b>ENVIRONMENTAL CONDITIONS</b> | 28 deg. C, 56%RH,<br>974 hPa               | <b>INPUT POWER (SYSTEM)</b> | 120Vac, 60Hz              |
| <b>TESTED BY</b>                | Eric Lee                                   |                             |                           |

**ANTENNA POLARITY & TEST DISTANCE: HORIZONTAL AT 3 M**

| No. | Freq. (MHz) | Emission Level (dBuV/m) | Limit (dBuV/m) | Margin (dB) | Antenna Height (m) | Table Angle (Degree) | Raw Value (dBuV) | Correction Factor (dB/m) |
|-----|-------------|-------------------------|----------------|-------------|--------------------|----------------------|------------------|--------------------------|
| 1   | #5088.00    | 54.6 PK                 | 74.00          | -19.40      | 1.09 H             | 8                    | 17.60            | 37.00                    |
| 1   | #5088.00    | 48.2 AV                 | 54.00          | -5.80       | 1.09 H             | 8                    | 11.20            | 37.00                    |
| 2   | #5150.00    | 51.9 PK                 | 74.00          | -22.10      | 1.06 H             | 113                  | 14.90            | 37.00                    |
| 2   | #5150.00    | 44.6 AV                 | 54.00          | -9.40       | 1.06 H             | 113                  | 7.60             | 37.00                    |
| 3   | *5210.00    | 93.7 PK                 |                |             | 1.45 H             | 24                   | 56.70            | 37.00                    |
| 3   | *5210.00    | 86.7 AV                 |                |             | 1.45 H             | 24                   | 49.70            | 37.00                    |
| 4   | #5440.00    | 49.4 PK                 | 74.00          | -24.60      | 1.25 H             | 236                  | 12.40            | 37.00                    |
| 5   | 10420.00    | 47.3 PK                 | 68.30          | -21.00      | 1.07 H             | 254                  | 2.50             | 44.80                    |

**ANTENNA POLARITY & TEST DISTANCE: VERTICAL AT 3 M**

| No. | Freq. (MHz) | Emission Level (dBuV/m) | Limit (dBuV/m) | Margin (dB) | Antenna Height (m) | Table Angle (Degree) | Raw Value (dBuV) | Correction Factor (dB/m) |
|-----|-------------|-------------------------|----------------|-------------|--------------------|----------------------|------------------|--------------------------|
| 1   | #5088.00    | 58.4 PK                 | 74.00          | -15.60      | 1.58 V             | 9                    | 21.30            | 37.00                    |
| 1   | #5088.00    | 49.6 AV                 | 54.00          | -4.40       | 1.58 V             | 9                    | 12.60            | 37.00                    |
| 2   | #5150.00    | 56.9 PK                 | 74.00          | -17.10      | 1.08 V             | 57                   | 19.90            | 37.00                    |
| 2   | #5150.00    | 49.2 AV                 | 54.00          | -4.80       | 1.08 V             | 57                   | 12.20            | 37.00                    |
| 3   | *5210.00    | 99.2 PK                 |                |             | 1.54 V             | 24                   | 62.20            | 37.00                    |
| 3   | *5210.00    | 92.2 AV                 |                |             | 1.54 V             | 24                   | 55.20            | 37.00                    |
| 4   | #5440.00    | 59.4 PK                 | 74.00          | -14.60      | 1.03 V             | 31                   | 22.30            | 37.00                    |
| 4   | #5440.00    | 50.4 AV                 | 54.00          | -3.60       | 1.03 V             | 31                   | 13.30            | 37.00                    |
| 5   | 10420.00    | 51.4 PK                 | 68.30          | -16.90      | 1.54 V             | 212                  | 6.50             | 44.80                    |

**NOTE:**

1. Emission level = Raw value - Correction Factor
2. Correction Factor = Pre-Amp. Factor - Ant. Factor - Cable loss  
(Pre-Amp. Factor = 0, when a Pre-Amplifier is not used for the test.)
3. Margin value = Emission level - Limit value
4. The other emission levels were very low against the limit.
5. "\*" : Fundamental frequency
6. "#" : The radiated frequency falling in the restricted band.



## STANDARD SECTION 15.407

|                                 |  |                             |                          |
|---------------------------------|--|-----------------------------|--------------------------|
| <b>EUT</b>                      | Wireless Dual Band Enterprise Access Point | <b>MODEL</b>                | RBT3K-AG                 |
| <b>MODE</b>                     | Turbo Mode                                 | <b>CHANNEL</b>              | 2                        |
| <b>FREQUENCY RANGE</b>          | 1000MHz~40000MHz                           | <b>DETECTOR FUNCTION</b>    | Peak(PK)<br>Average (AV) |
| <b>ENVIRONMENTAL CONDITIONS</b> | 28 deg. C, 56%RH,<br>974 hPa               | <b>INPUT POWER (SYSTEM)</b> | 120Vac, 60Hz             |
| <b>TESTED BY</b>                | Eric Lee                                   |                             |                          |

**ANTENNA POLARITY & TEST DISTANCE: HORIZONTAL AT 3 M**

| No. | Freq. (MHz) | Emission Level (dBuV/m) | Limit (dBuV/m) | Margin (dB) | Antenna Height (m) | Table Angle (Degree) | Raw Value (dBuV) | Correction Factor (dB/m) |
|-----|-------------|-------------------------|----------------|-------------|--------------------|----------------------|------------------|--------------------------|
| 1   | #5120.00    | 52.2 PK                 | 74.00          | -21.80      | 1.30 H             | 269                  | 15.10            | 37.00                    |
| 1   | #5120.00    | 44.6 AV                 | 54.00          | -9.40       | 1.30 H             | 269                  | 7.60             | 37.00                    |
| 2   | *5250.00    | 95.3 PK                 |                |             | 1.41 H             | 29                   | 58.30            | 37.00                    |
| 2   | *5250.00    | 87.1 AV                 |                |             | 1.41 H             | 29                   | 50.10            | 37.00                    |
| 3   | #5408.00    | 50.8 PK                 | 74.00          | -23.20      | 1.36 H             | 5                    | 13.70            | 37.00                    |
| 4   | 10500.00    | 50.9 PK                 | 68.30          | -17.40      | 1.08 H             | 222                  | 5.90             | 45.00                    |

**ANTENNA POLARITY & TEST DISTANCE: VERTICAL AT 3 M**

| No. | Freq. (MHz) | Emission Level (dBuV/m) | Limit (dBuV/m) | Margin (dB) | Antenna Height (m) | Table Angle (Degree) | Raw Value (dBuV) | Correction Factor (dB/m) |
|-----|-------------|-------------------------|----------------|-------------|--------------------|----------------------|------------------|--------------------------|
| 1   | #5120.00    | 51.4 PK                 | 74.00          | -22.60      | 1.04 V             | 249                  | 14.40            | 37.00                    |
| 1   | #5120.00    | 46.2 AV                 | 54.00          | -7.80       | 1.04 V             | 249                  | 9.20             | 37.00                    |
| 2   | *5250.00    | 100.5 PK                |                |             | 1.30 V             | 25                   | 63.50            | 37.00                    |
| 2   | *5250.00    | 93.2 AV                 |                |             | 1.30 V             | 25                   | 56.20            | 37.00                    |
| 3   | #5408.00    | 57.2 PK                 | 74.00          | -16.80      | 1.06 V             | 329                  | 20.20            | 37.00                    |
| 3   | #5408.00    | 50.4 AV                 | 54.00          | -3.60       | 1.06 V             | 329                  | 13.40            | 37.00                    |
| 4   | 10500.00    | 52.0 PK                 | 68.30          | -16.20      | 1.00 V             | 28                   | 7.00             | 45.00                    |

**NOTE:**

- Emission level = Raw value - Correction Factor
- Correction Factor = Pre-Amp. Factor - Ant. Factor - Cable loss  
(Pre-Amp. Factor = 0, when a Pre-Amplifier is not used for the test.)
- Margin value = Emission level - Limit value
- The other emission levels were very low against the limit.
- "\*": Fundamental frequency
- "#": The radiated frequency falling in the restricted band.



## STANDARD SECTION 15.407

|                                 |  |                             |                          |
|---------------------------------|--|-----------------------------|--------------------------|
| <b>EUT</b>                      | Wireless Dual Band Enterprise Access Point | <b>MODEL</b>                | RBT3K-AG                 |
| <b>MODE</b>                     | Turbo Mode                                 | <b>CHANNEL</b>              | 3                        |
| <b>FREQUENCY RANGE</b>          | 1000MHz~40000MHz                           | <b>DETECTOR FUNCTION</b>    | Peak(PK)<br>Average (AV) |
| <b>ENVIRONMENTAL CONDITIONS</b> | 28 deg. C, 56%RH,<br>974 hPa               | <b>INPUT POWER (SYSTEM)</b> | 120Vac, 60Hz             |
| <b>TESTED BY</b>                | Eric Lee                                   |                             |                          |

**ANTENNA POLARITY & TEST DISTANCE: HORIZONTAL AT 3 M**

| No. | Freq. (MHz) | Emission Level (dBuV/m) | Limit (dBuV/m) | Margin (dB) | Antenna Height (m) | Table Angle (Degree) | Raw Value (dBuV) | Correction Factor (dB/m) |
|-----|-------------|-------------------------|----------------|-------------|--------------------|----------------------|------------------|--------------------------|
| 1   | #5088.00    | 51.0 PK                 | 74.00          | -23.00      | 1.30 H             | 61                   | 13.90            | 37.00                    |
| 1   | #5088.00    | 44.6 AV                 | 54.00          | -9.40       | 1.30 H             | 61                   | 7.50             | 37.00                    |
| 2   | *5290.00    | 95.1 PK                 |                |             | 1.58 H             | 99                   | 58.00            | 37.00                    |
| 2   | *5290.00    | 86.7 AV                 |                |             | 1.58 H             | 99                   | 49.60            | 37.00                    |
| 3   | #5350.00    | 51.2 PK                 | 74.00          | -22.80      | 1.33 H             | 119                  | 14.10            | 37.00                    |
| 3   | #5350.00    | 41.0 AV                 | 54.00          | -13.00      | 1.33 H             | 119                  | 4.00             | 37.00                    |
| 4   | #5408.00    | 50.4 PK                 | 74.00          | -23.60      | 1.54 H             | 26                   | 13.40            | 37.00                    |
| 5   | 10580.00    | 51.8 PK                 | 68.30          | -16.50      | 1.35 H             | 26                   | 6.00             | 45.70                    |

**ANTENNA POLARITY & TEST DISTANCE: VERTICAL AT 3 M**

| No. | Freq. (MHz) | Emission Level (dBuV/m) | Limit (dBuV/m) | Margin (dB) | Antenna Height (m) | Table Angle (Degree) | Raw Value (dBuV) | Correction Factor (dB/m) |
|-----|-------------|-------------------------|----------------|-------------|--------------------|----------------------|------------------|--------------------------|
| 1   | #5088.00    | 56.0 PK                 | 74.00          | -18.00      | 1.11 V             | 9                    | 19.00            | 37.00                    |
| 1   | #5088.00    | 49.6 AV                 | 54.00          | -4.40       | 1.11 V             | 9                    | 12.60            | 37.00                    |
| 2   | *5290.00    | 98.9 PK                 |                |             | 1.00 V             | 0                    | 61.90            | 37.00                    |
| 2   | *5290.00    | 91.2 AV                 |                |             | 1.00 V             | 0                    | 54.20            | 37.00                    |
| 3   | #5350.00    | 57.0 PK                 | 74.00          | -17.00      | 1.05 V             | 24                   | 20.00            | 37.00                    |
| 3   | #5350.00    | 47.8 AV                 | 54.00          | -6.20       | 1.05 V             | 24                   | 10.80            | 37.00                    |
| 4   | #5408.00    | 59.4 PK                 | 74.00          | -14.60      | 1.05 V             | 24                   | 22.30            | 37.00                    |
| 4   | #5408.00    | 50.8 AV                 | 54.00          | -3.20       | 1.05 V             | 24                   | 13.70            | 37.00                    |
| 5   | 10580.00    | 55.1 PK                 | 68.30          | -13.20      | 1.52 V             | 329                  | 9.40             | 45.70                    |

**NOTE:**

1. Emission level = Raw value - Correction Factor
2. Correction Factor = Pre-Amp. Factor - Ant. Factor - Cable loss  
(Pre-Amp. Factor = 0, when a Pre-Amplifier is not used for the test.)
3. Margin value = Emission level - Limit value
4. The other emission levels were very low against the limit.
5. "\*" : Fundamental frequency
6. "#": The radiated frequency falling in the restricted band.



## STANDARD SECTION 15.247

|                                 |  |                             |                          |
|---------------------------------|--|-----------------------------|--------------------------|
| <b>EUT</b>                      | Wireless Dual Band Enterprise Access Point | <b>MODEL</b>                | RBT3K-AG                 |
| <b>MODE</b>                     | Turbo Mode                                 | <b>CHANNEL</b>              | 4                        |
| <b>FREQUENCY RANGE</b>          | 1000MHz~40000MHz                           | <b>DETECTOR FUNCTION</b>    | Peak(PK)<br>Average (AV) |
| <b>ENVIRONMENTAL CONDITIONS</b> | 26 deg. C, 67%RH,<br>974 hPa               | <b>INPUT POWER (SYSTEM)</b> | 120Vac, 60Hz             |
| <b>TESTED BY</b>                | Eric Lee                                   |                             |                          |

**ANTENNA POLARITY & TEST DISTANCE: HORIZONTAL AT 3 M**

| No. | Freq. (MHz) | Emission Level (dBuV/m) | Limit (dBuV/m) | Margin (dB) | Antenna Height (m) | Table Angle (Degree) | Raw Value (dBuV) | Correction Factor (dB/m) |
|-----|-------------|-------------------------|----------------|-------------|--------------------|----------------------|------------------|--------------------------|
| 1   | #5120.00    | 46.60 PK                | 74.00          | -27.40      | 1.65 H             | 25                   | 9.60             | 37.00                    |
| 2   | #5376.00    | 49.50 PK                | 74.00          | -24.50      | 1.59 H             | 325                  | 12.50            | 37.00                    |
| 3   | #5440.00    | 49.90 PK                | 74.00          | -24.10      | 1.11 H             | 9                    | 12.90            | 37.00                    |
| 4   | *5760.00    | 93.60 PK                |                |             | 1.63 H             | 30                   | 56.00            | 37.60                    |
| 4   | *5760.00    | 86.50 AV                |                |             | 1.63 H             | 30                   | 49.00            | 37.60                    |
| 5   | #11520.00   | 50.10 PK                | 74.00          | -23.90      | 1.05 H             | 42                   | -1.20            | 51.30                    |

**ANTENNA POLARITY & TEST DISTANCE: VERTICAL AT 3 M**

| No. | Freq. (MHz) | Emission Level (dBuV/m) | Limit (dBuV/m) | Margin (dB) | Antenna Height (m) | Table Angle (Degree) | Raw Value (dBuV) | Correction Factor (dB/m) |
|-----|-------------|-------------------------|----------------|-------------|--------------------|----------------------|------------------|--------------------------|
| 1   | #5120.00    | 51.90 PK                | 74.00          | -22.10      | 1.02 V             | 41                   | 14.80            | 37.00                    |
| 1   | #5120.00    | 48.40 AV                | 54.00          | -5.60       | 1.02 V             | 41                   | 11.30            | 37.00                    |
| 2   | #5376.00    | 57.30 PK                | 74.00          | -16.70      | 1.42 V             | 36                   | 20.20            | 37.00                    |
| 2   | #5376.00    | 48.10 AV                | 54.00          | -5.90       | 1.42 V             | 36                   | 11.10            | 37.00                    |
| 3   | #5440.00    | 59.00 PK                | 74.00          | -15.00      | 1.56 V             | 62                   | 21.90            | 37.00                    |
| 3   | #5440.00    | 50.00 AV                | 54.00          | -4.00       | 1.56 V             | 62                   | 12.90            | 37.00                    |
| 4   | *5760.00    | 99.70 PK                |                |             | 1.54 V             | 21                   | 62.10            | 37.60                    |
| 4   | *5760.00    | 92.80 AV                |                |             | 1.54 V             | 21                   | 55.30            | 37.60                    |
| 5   | #11520.00   | 54.60 PK                | 74.00          | -19.40      | 1.68 V             | 95                   | 3.30             | 51.30                    |
| 5   | #11520.00   | 46.80 AV                | 54.00          | -7.20       | 1.68 V             | 95                   | -4.50            | 51.30                    |

**NOTE:**

Emission level = Raw value - Correction Factor

Correction Factor = Pre-Amp. Factor - Ant. Factor - Cable loss

(Pre-Amp. Factor = 0, when a Pre-Amplifier is not used for the test.)

Margin value = Emission level - Limit value

The other emission levels were very low against the limit.

“\*” : Fundamental frequency

“# “ :The radiated frequency falling in the restricted band.



## STANDARD SECTION 15.247

|                                 |  |                             |                          |
|---------------------------------|--|-----------------------------|--------------------------|
| <b>EUT</b>                      | Wireless Dual Band Enterprise Access Point | <b>MODEL</b>                | RBT3K-AG                 |
| <b>MODE</b>                     | Turbo Mode                                 | <b>CHANNEL</b>              | 5                        |
| <b>FREQUENCY RANGE</b>          | 1000MHz~40000MHz                           | <b>DETECTOR FUNCTION</b>    | Peak(PK)<br>Average (AV) |
| <b>ENVIRONMENTAL CONDITIONS</b> | 28 deg. C, 56%RH,<br>974 hPa               | <b>INPUT POWER (SYSTEM)</b> | 120Vac, 60Hz             |
| <b>TESTED BY</b>                | Eric Lee                                   |                             |                          |

**ANTENNA POLARITY & TEST DISTANCE: HORIZONTAL AT 3 M**

| No. | Freq. (MHz) | Emission Level (dBuV/m) | Limit (dBuV/m) | Margin (dB) | Antenna Height (m) | Table Angle (Degree) | Raw Value (dBuV) | Correction Factor (dB/m) |
|-----|-------------|-------------------------|----------------|-------------|--------------------|----------------------|------------------|--------------------------|
| 1   | #5120.00    | 47.20 PK                | 74.00          | -26.80      | 1.35 H             | 26                   | 10.20            | 37.00                    |
| 2   | #5376.00    | 51.30 PK                | 74.00          | -22.70      | 1.55 H             | 201                  | 14.20            | 37.00                    |
| 2   | #5376.00    | 42.60 AV                | 54.00          | -11.40      | 1.55 H             | 201                  | 5.60             | 37.00                    |
| 3   | #5440.00    | 51.20 PK                | 74.00          | -22.80      | 1.02 H             | 32                   | 14.20            | 37.00                    |
| 3   | #5440.00    | 42.90 AV                | 54.00          | -11.10      | 1.02 H             | 32                   | 5.90             | 37.00                    |
| 4   | *5800.00    | 91.70 PK                |                |             | 1.56 H             | 6                    | 54.00            | 37.70                    |
| 4   | *5800.00    | 86.20 AV                |                |             | 1.56 H             | 6                    | 48.60            | 37.70                    |
| 5   | #11600.00   | 49.80 PK                | 74.00          | -24.20      | 1.63 H             | 6                    | -1.20            | 51.00                    |

**ANTENNA POLARITY & TEST DISTANCE: VERTICAL AT 3 M**

| No. | Freq. (MHz) | Emission Level (dBuV/m) | Limit (dBuV/m) | Margin (dB) | Antenna Height (m) | Table Angle (Degree) | Raw Value (dBuV) | Correction Factor (dB/m) |
|-----|-------------|-------------------------|----------------|-------------|--------------------|----------------------|------------------|--------------------------|
| 1   | #5120.00    | 51.80 PK                | 74.00          | -22.20      | 1.56 V             | 326                  | 14.80            | 37.00                    |
| 1   | #5120.00    | 47.40 AV                | 54.00          | -6.60       | 1.56 V             | 326                  | 10.30            | 37.00                    |
| 2   | #5376.00    | 57.30 PK                | 74.00          | -16.70      | 1.25 V             | 66                   | 20.20            | 37.00                    |
| 2   | #5376.00    | 47.50 AV                | 54.00          | -6.50       | 1.25 V             | 66                   | 10.40            | 37.00                    |
| 3   | #5440.00    | 58.10 PK                | 74.00          | -15.90      | 1.02 V             | 58                   | 21.00            | 37.00                    |
| 3   | #5440.00    | 49.00 AV                | 54.00          | -5.00       | 1.02 V             | 58                   | 11.90            | 37.00                    |
| 4   | *5800.00    | 101.70 PK               |                |             | 1.45 V             | 24                   | 64.00            | 37.70                    |
| 4   | *5800.00    | 93.90 AV                |                |             | 1.45 V             | 24                   | 56.30            | 37.70                    |
| 5   | #11600.00   | 56.20 PK                | 74.00          | -17.80      | 1.42 V             | 10                   | 5.20             | 51.00                    |
| 5   | #11600.00   | 46.90 AV                | 54.00          | -7.10       | 1.42 V             | 10                   | -4.10            | 51.00                    |

**NOTE:**

Emission level = Raw value - Correction Factor

Correction Factor = Pre-Amp. Factor - Ant. Factor - Cable loss

(Pre-Amp. Factor = 0, when a Pre-Amplifier is not used for the test.)

Margin value = Emission level - Limit value

The other emission levels were very low against the limit.

“\*” : Fundamental frequency

“#” : The radiated frequency falling in the restricted band.



**FOR FREQUENCY 5.15~5.35GHZ**

**5.3 PEAK TRANSMIT POWER MEASUREMENT**

**5.3.1 LIMITS OF PEAK TRANSMIT POWER MEASUREMENT**

| Frequency Band    | Limit   |
|-------------------|---|
| 5.15 – 5.25 GHz   | The lesser of 50mW (17dBm) or 4dBm + 10logB   |
| 5.25 – 5.35 GHz   | The lesser of 250mW (24dBm) or 11dBm + 10logB |
| 5.725 – 5.825 GHz | The lesser of 1W (30dBm) or 17dBm + 10logB    |

**Note:** Where B is the 26dB emission bandwidth in MHz.

**5.3.2 TEST INSTRUMENTS**

| Description & Manufacturer | Model No. | Serial No. | Calibrated Until |
|----------------------------|-----------|------------|------------------|
| R&S SPECTRUM ANALYZER      | FSP30     | 100019     | Dec. 19, 2003    |

**NOTE:**

The calibration interval of the above test instruments is 12 months and the calibrations are traceable to NML/ROC and NIST/USA.



### 5.3.3 TEST PROCEDURE

1. The transmitter output was connected to the spectrum analyzer.
2. Set span to encompass the entire emission bandwidth of the signal.
3. Set RBW to 1MHz, VBW to 300kHz.
4. Using the spectrum analyzer's channel power measurement function to measure the output power.

### 5.3.4 TEST SETUP

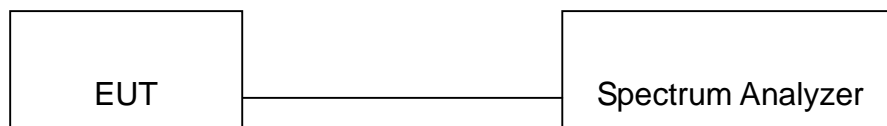

### 5.3.5 EUT OPERATING CONDITIONS

The software provided by client to enable the EUT under transmission condition continuously at specific channel frequencies individually.



## 5.3.6 TEST RESULTS

|                                 |  |                             |               |
|---------------------------------|--|-----------------------------|---------------|
| <b>EUT</b>                      | Wireless Dual Band Enterprise Access Point | <b>MODEL</b>                | RBT3K-AG      |
| <b>MODE</b>                     | Normal                                     | <b>INPUT POWER (SYSTEM)</b> | 120Vac, 60 Hz |
| <b>ENVIRONMENTAL CONDITIONS</b> | 21eg. C, 58RH, 974 hPa                     | <b>TESTED BY</b>            | Eric Lee      |

| <b>CHANNEL</b> | <b>CHANNEL FREQUENCY (MHz)</b> | <b>PEAK POWER OUTPUT (dBm)</b> | <b>PEAK POWER LIMIT (dBm)</b> | <b>26dBc Occupied Bandwidth (MHz)</b> | <b>PASS/FAIL</b> |
|----------------|--------------------------------|--------------------------------|-------------------------------|---------------------------------------|------------------|
| 1              | 5180                           | 15.13                          | 17.00                         | 30.56                                 | PASS             |
| 4              | 5240                           | 15.37                          | 17.00                         | 30.80                                 | PASS             |
| 5              | 5260                           | 19.90                          | 24.00                         | 29.52                                 | PASS             |
| 8              | 5320                           | 15.14                          | 24.00                         | 30.32                                 | PASS             |

**NOTE:** The 26dBc Occupied Bandwidth plot, please refer to the following pages.



CHANNEL 1

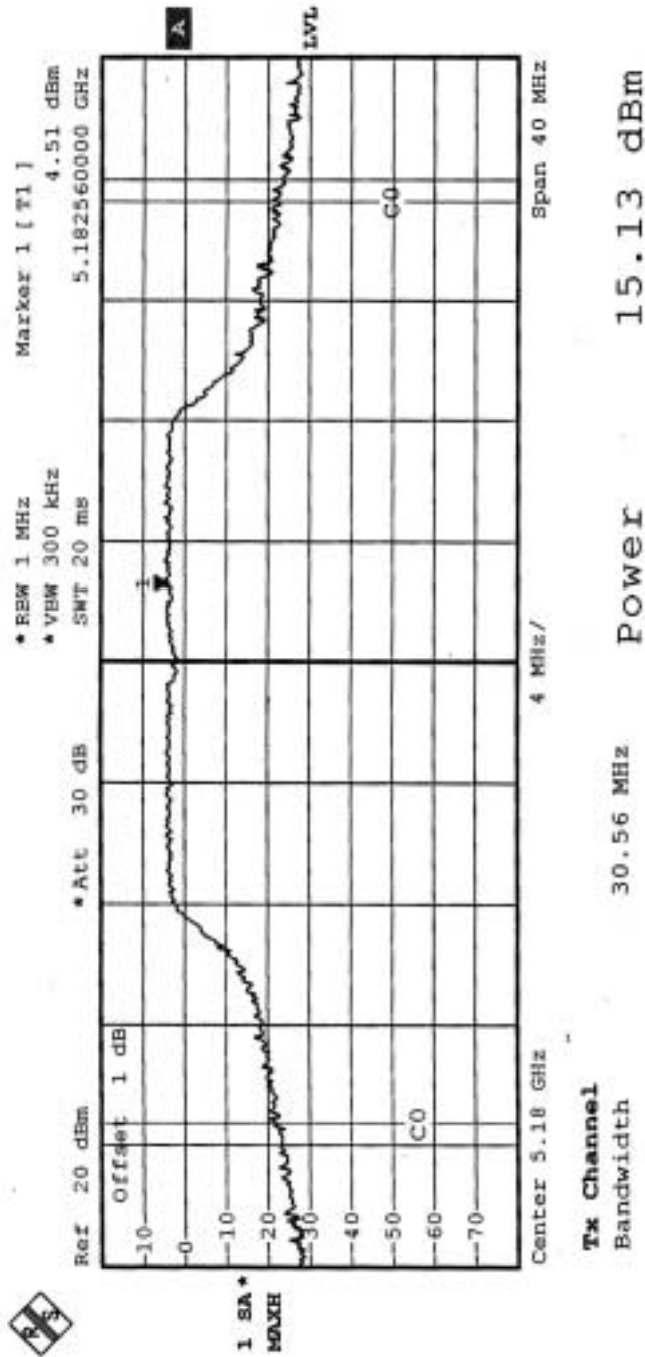



CHANNEL 4

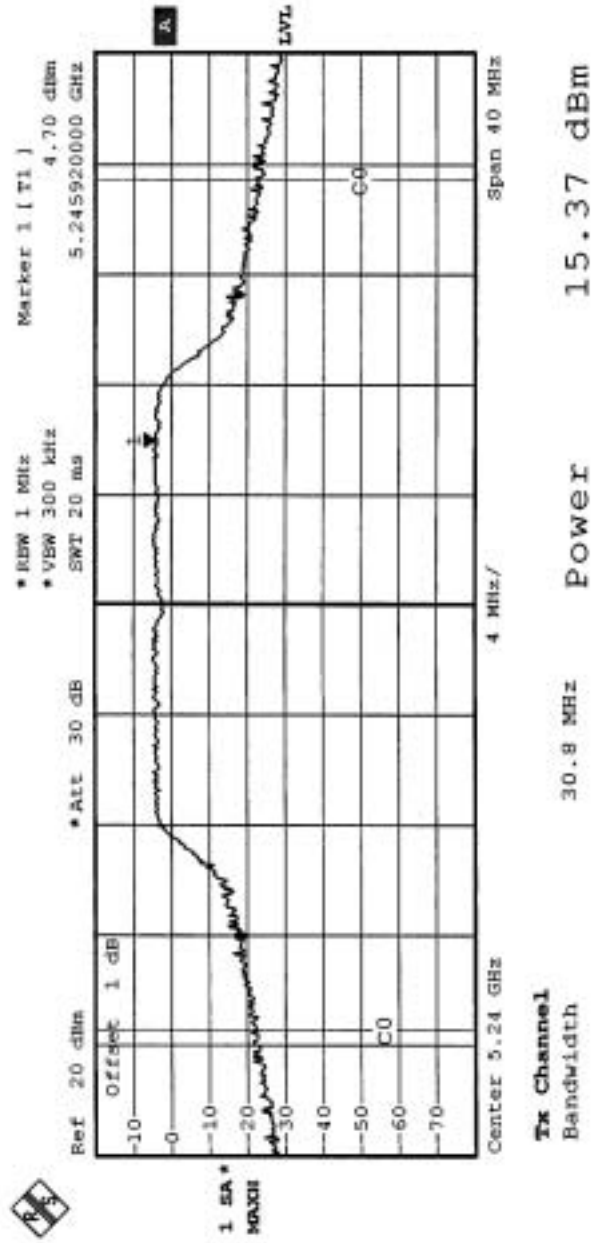



CHANNEL 5

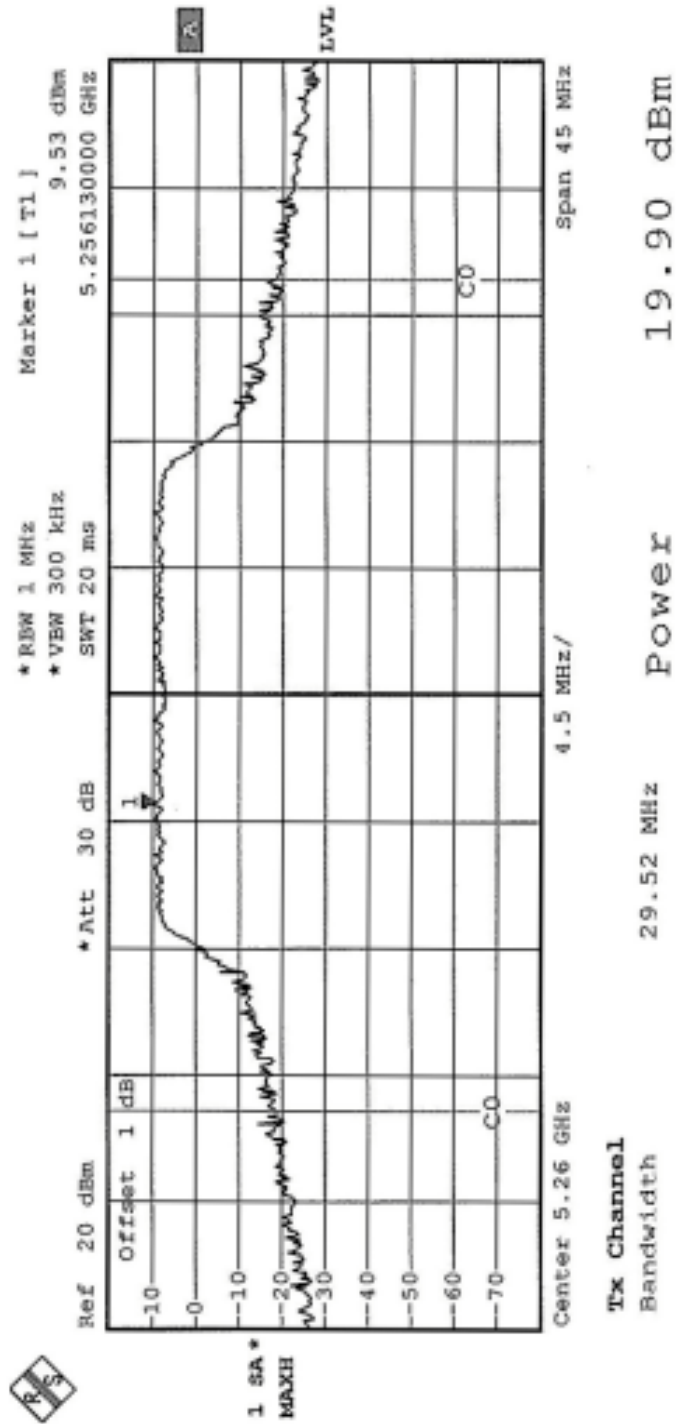



CHANNEL 8

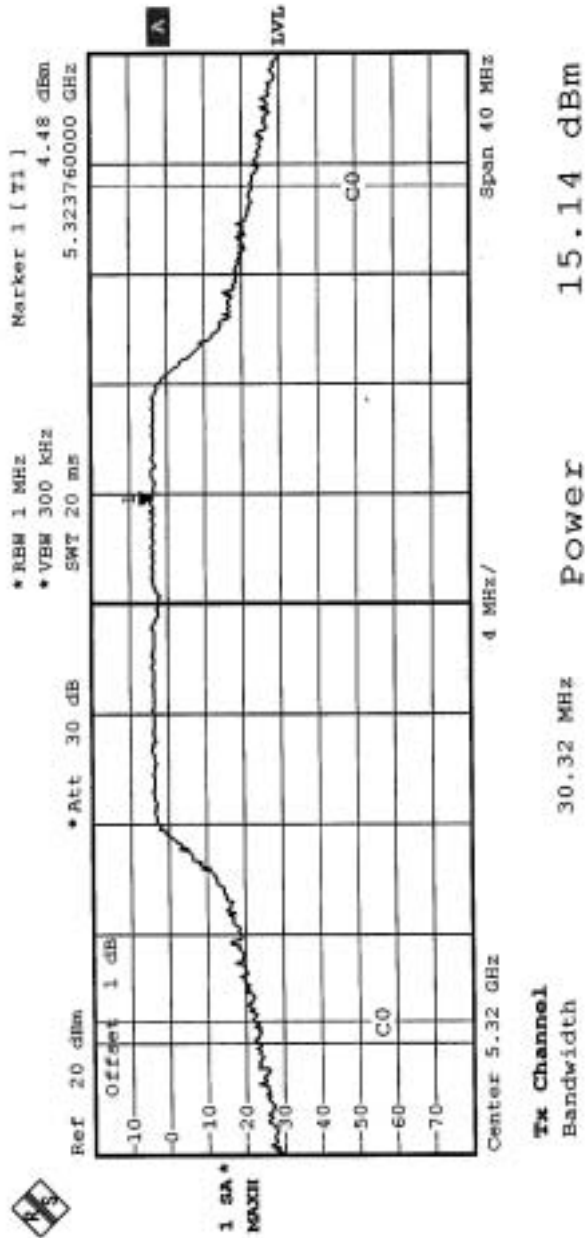



CHANNEL 1

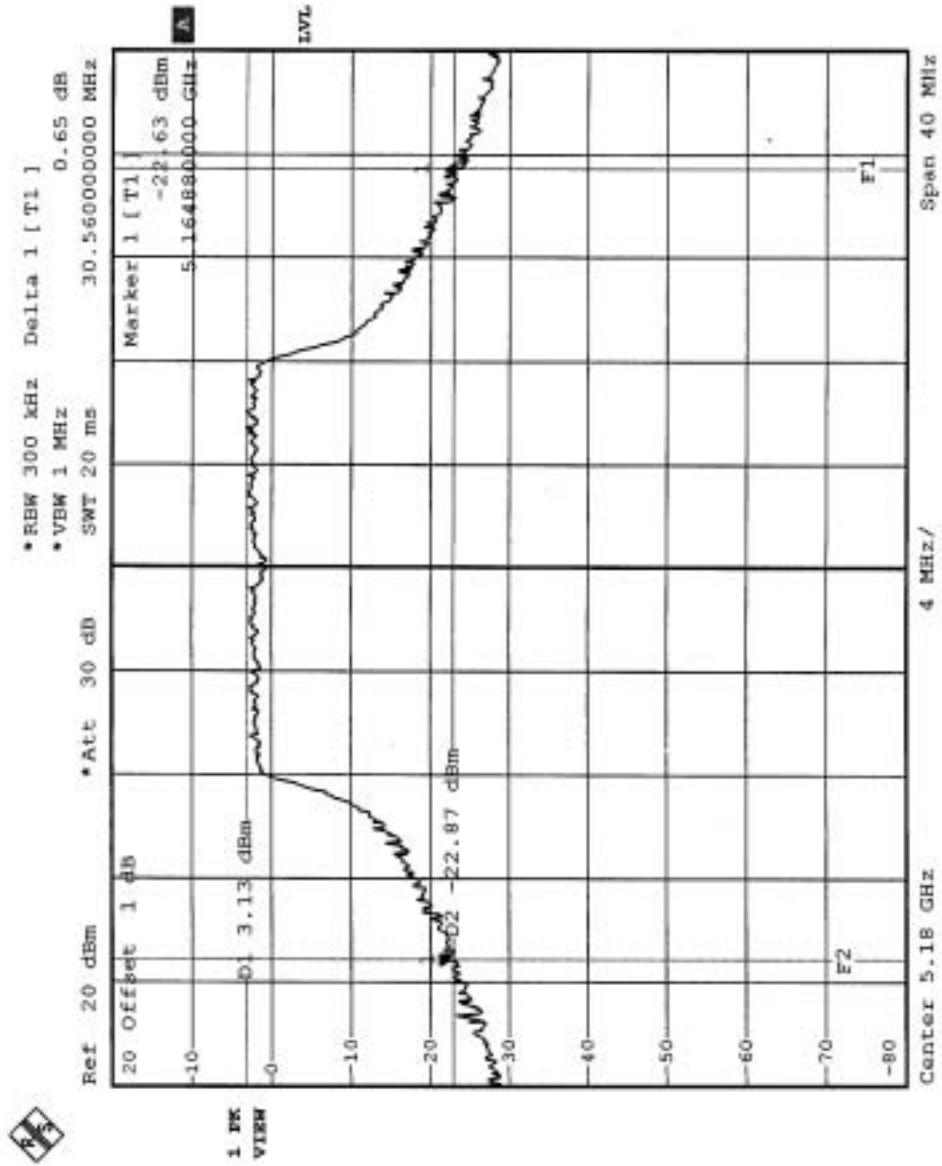



CHANNEL 4

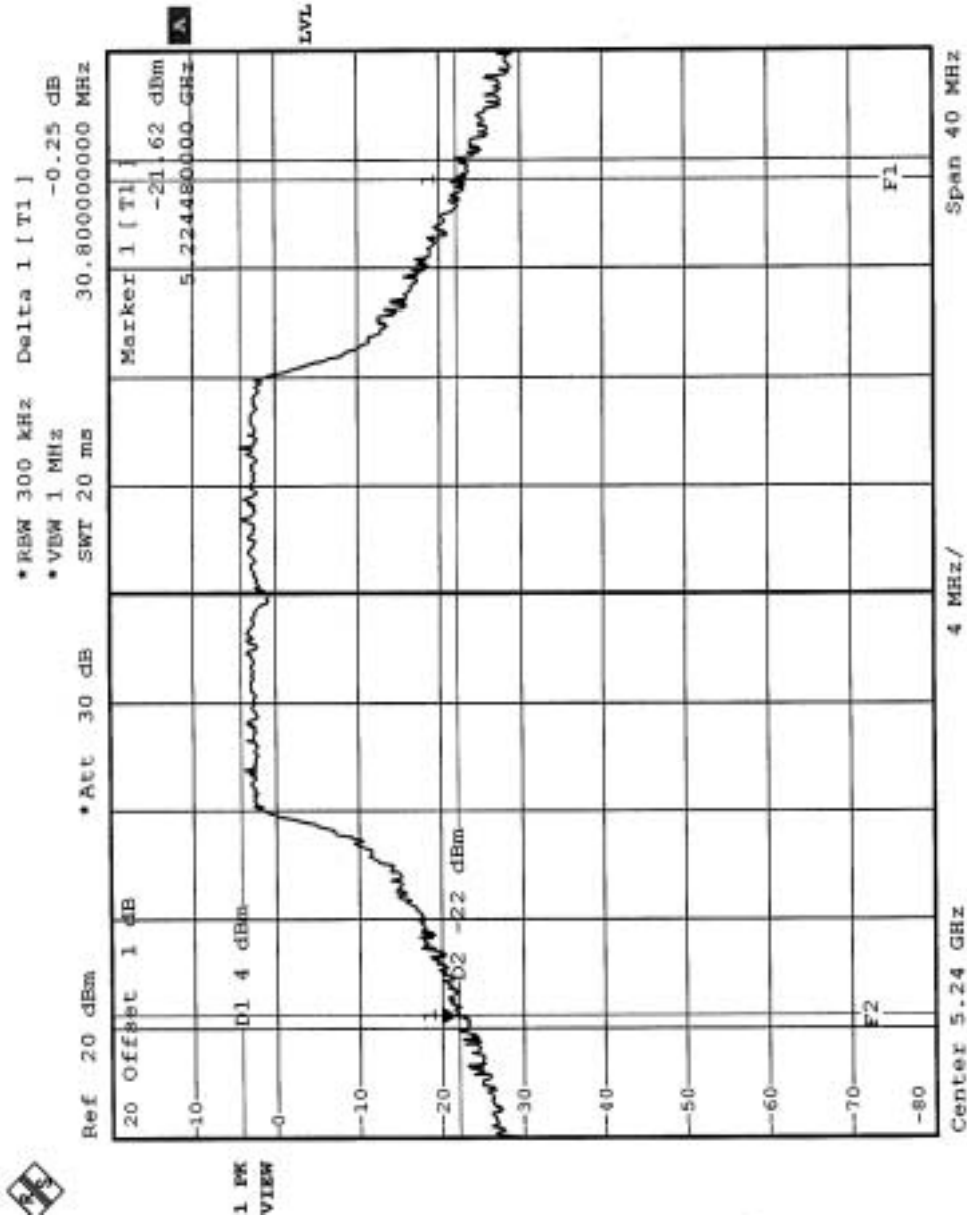





CHANNEL 5

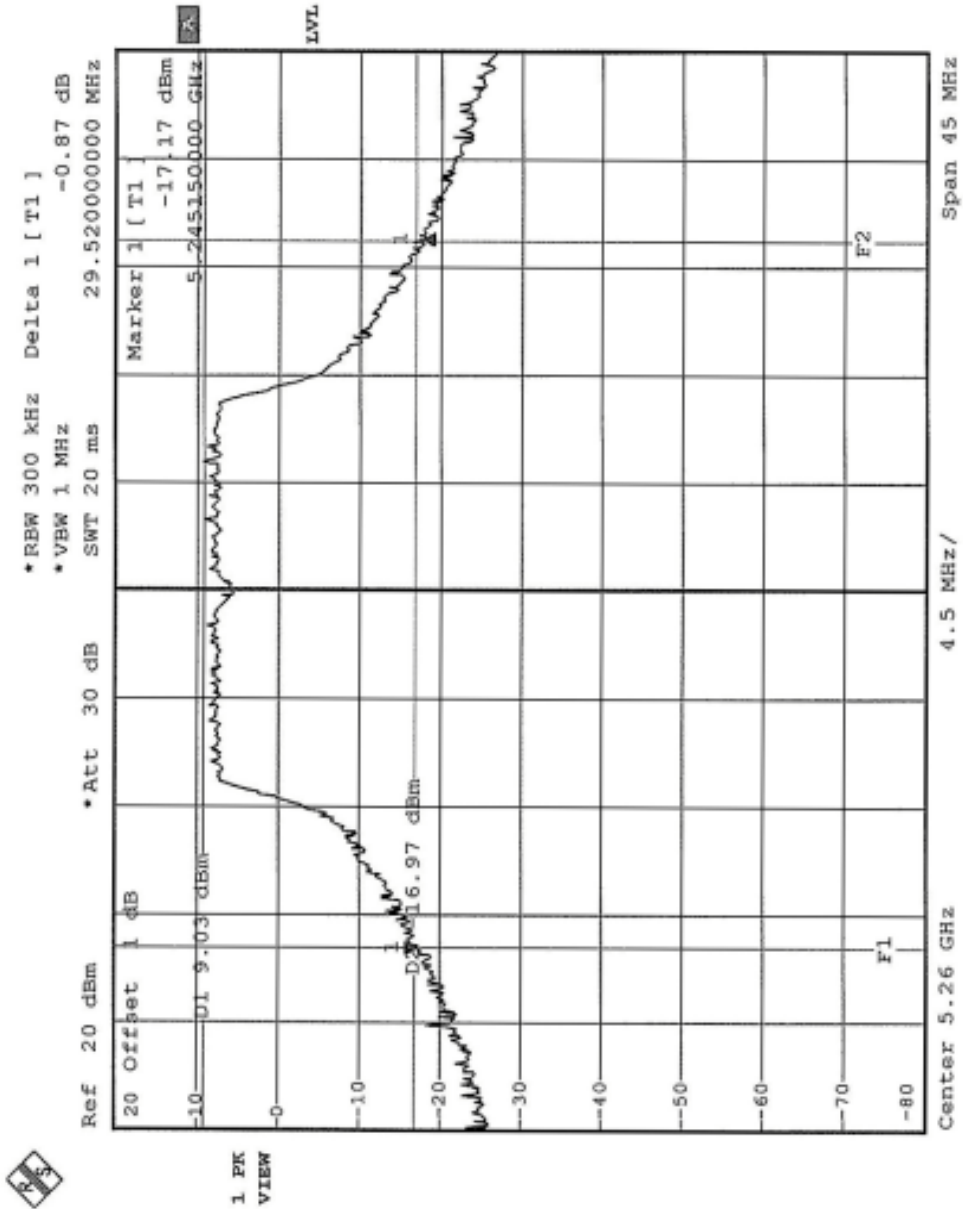



CHANNEL 8

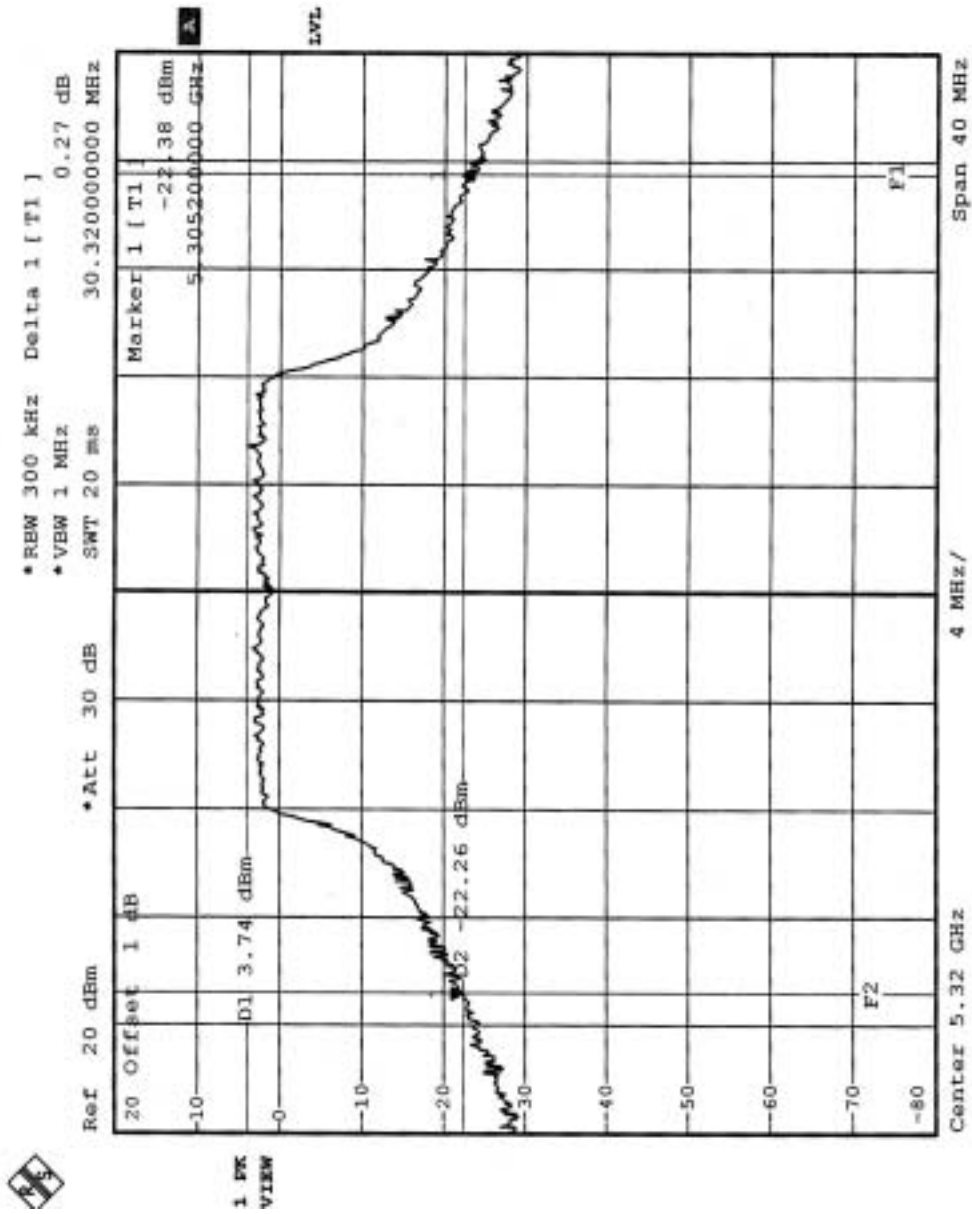



|                                 |  |                             |               |
|---------------------------------|--|-----------------------------|---------------|
| <b>EUT</b>                      | Wireless Dual Band Enterprise Access Point | <b>MODEL</b>                | RBT3K-AG      |
| <b>MODE</b>                     | Turbo                                      | <b>INPUT POWER (SYSTEM)</b> | 120Vac, 60 Hz |
| <b>ENVIRONMENTAL CONDITIONS</b> | 25deg. C, 66RH, 974 hPa                    | <b>TESTED BY</b>            | Eric Lee      |

| <b>CHANNEL</b> | <b>CHANNEL FREQUENCY (MHz)</b> | <b>PEAK POWER OUTPUT (dBm)</b> | <b>PEAK POWER LIMIT (dBm)</b> | <b>26dBc Occupied Bandwidth (MHz)</b> | <b>PASS/FAIL</b> |
|----------------|--------------------------------|--------------------------------|-------------------------------|---------------------------------------|------------------|
| 1              | 5210                           | 15.13                          | 17.00                         | 59.84                                 | PASS             |
| 2              | 5250                           | 15.53                          | 24.00                         | 57.60                                 | PASS             |
| 3              | 5290                           | 15.57                          | 24.00                         | 60.96                                 | PASS             |

**NOTE:** The 26dBc Occupied Bandwidth plot, please refer to the following pages.



CHANNEL 1

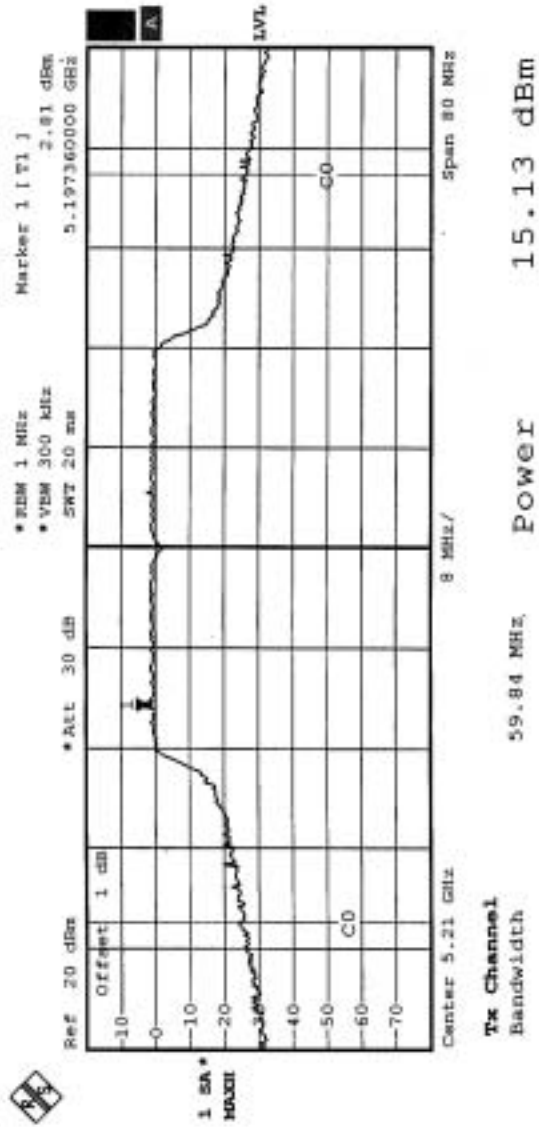



CHANNEL 2

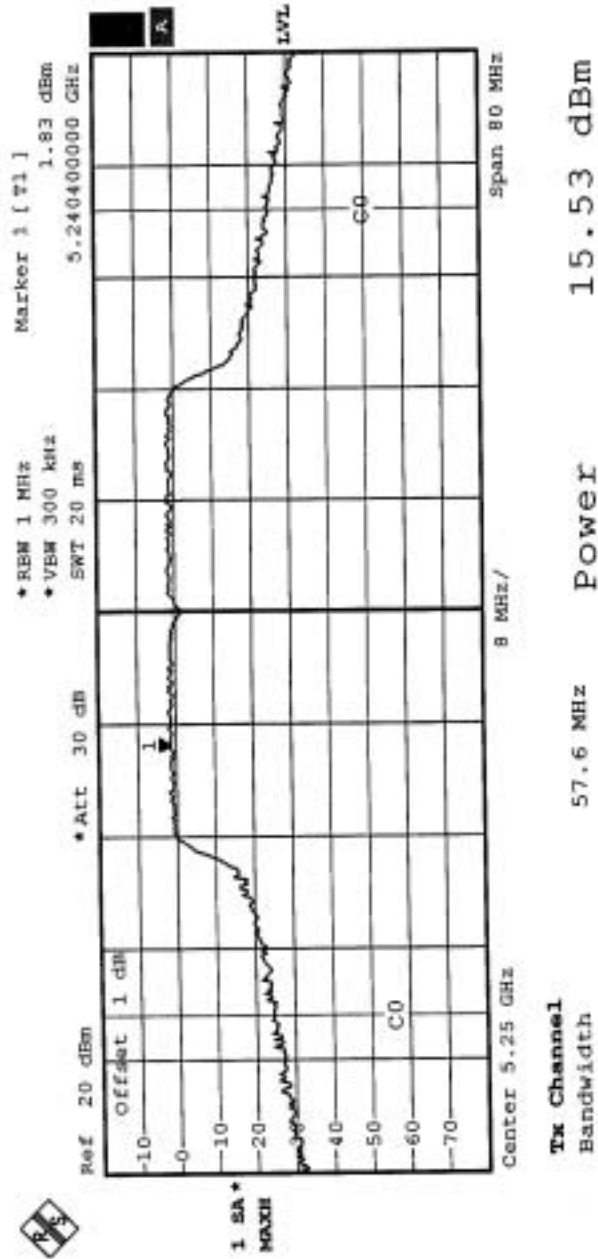



CHANNEL 3

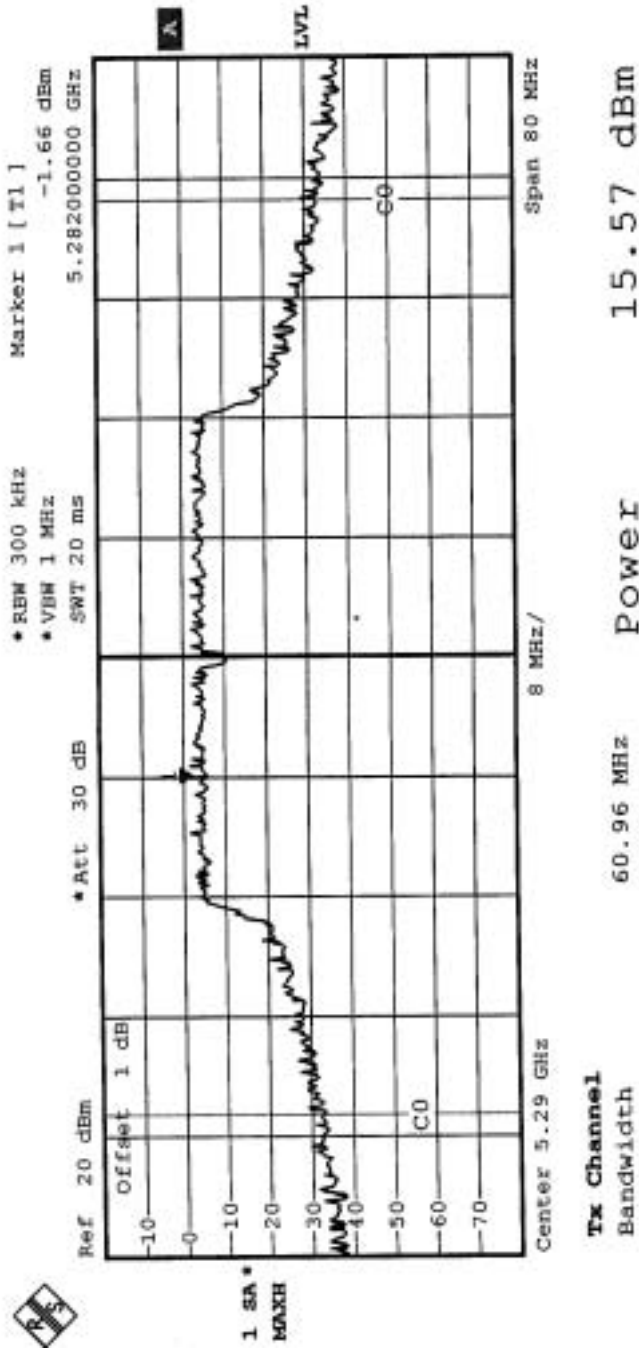



CHANNEL 1

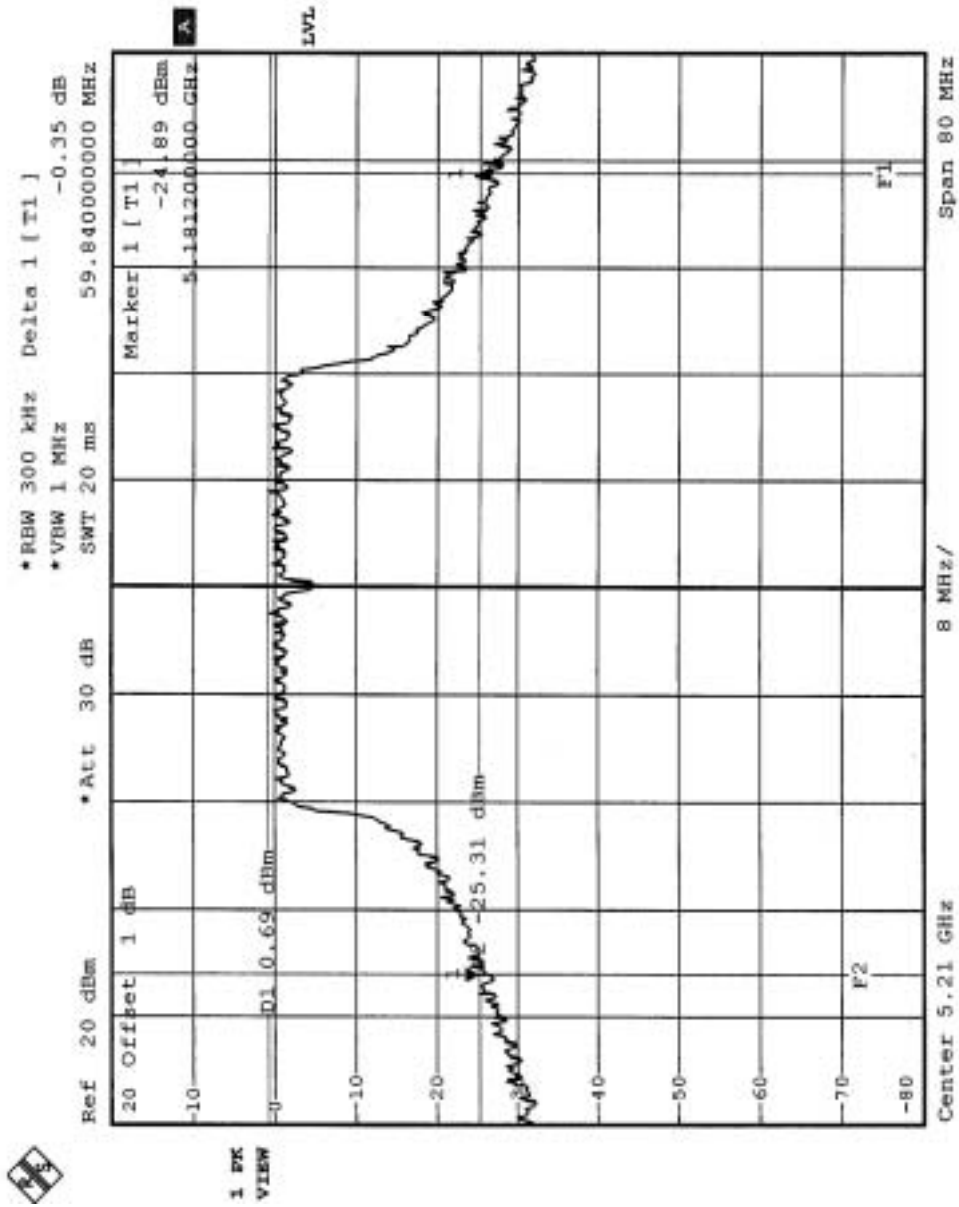



CHANNEL 2

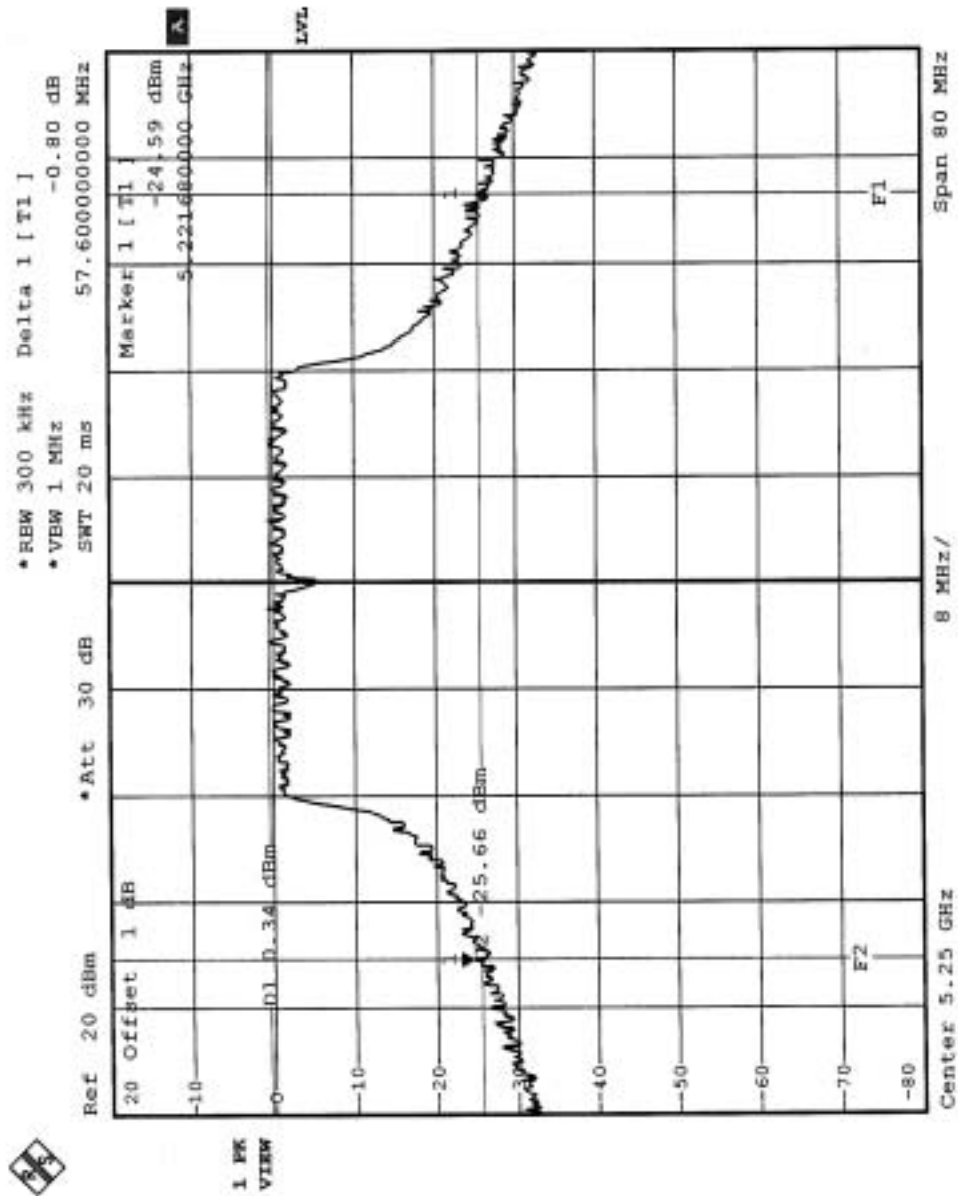





CHANNEL 3

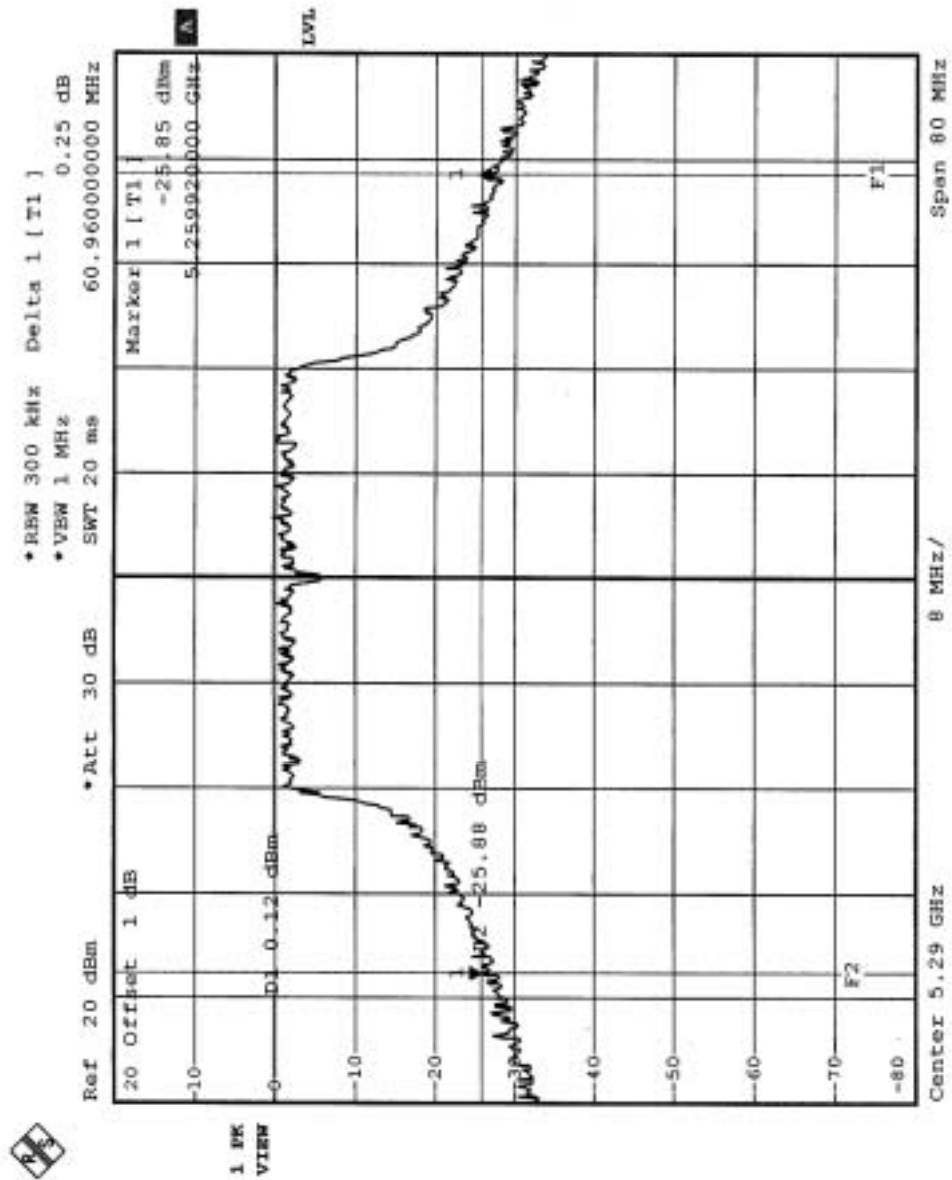



## 5.4 PEAK POWER EXCURSION MEASUREMENT

### 5.4.1 LIMITS OF PEAK POWER EXCURSION MEASUREMENT

| Frequency Band    | Limit |
|-------------------|-------|
| 5.15 – 5.25 GHz   | 13dB  |
| 5.25 – 5.35 GHz   | 13dB  |
| 5.725 – 5.825 GHz | 13dB  |

### 5.4.2 TEST INSTRUMENTS

| Description & Manufacturer | Model No. | Serial No. | Calibrated Until |
|----------------------------|-----------|------------|------------------|
| R&S SPECTRUM ANALYZER      | FSP30     | 100019     | Dec. 19, 2003    |

**NOTE:**

The calibration interval of the above test instruments is 12 months and the calibrations are traceable to NML/ROC and NIST/USA.



### 5.4.3 TEST PROCEDURE

1. The transmitter output was connected to the spectrum analyzer.
2. Set the spectrum bandwidth span to view the entire spectrum.
3. Using peak detector and Max-hold function for Trace 1 (RB=1MHz, VB=3MHz) and 2 (RB=1MHz, VB=30KHz).
4. The largest difference between Trace 1 and Trace 2 in any 1MHz band on any frequency was recorded.

### 5.4.4 DEVIATION FROM TEST STANDARD

No deviation

### 5.4.5 TEST SETUP

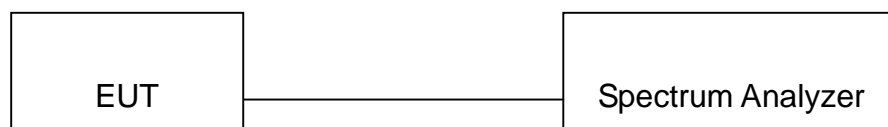

### 5.4.6 EUT OPERATING CONDITIONS

The software provided by client to enable the EUT under transmission condition continuously at specific channel frequencies individually.



## 5.4.7 TEST RESULTS

|                                 |  |                             |               |
|---------------------------------|--|-----------------------------|---------------|
| <b>EUT</b>                      | Wireless Dual Band Enterprise Access Point | <b>MODEL</b>                | RBT3K-AG      |
| <b>MODE</b>                     | Normal                                     | <b>INPUT POWER (SYSTEM)</b> | 120Vac, 60 Hz |
| <b>ENVIRONMENTAL CONDITIONS</b> | 21eg. C, 58RH, 974 hPa                     | <b>TESTED BY</b>            | Eric Lee      |

| <b>CHANNEL</b> | <b>CHANNEL FREQUENCY (MHz)</b> | <b>PEAK POWER EXCURSION (dB)</b> | <b>PEAK to AVERAGE EXCURSION LIMIT (dB)</b> | <b>PASS/FAIL</b> |
|----------------|--------------------------------|----------------------------------|---|------------------|
| 1              | 5180                           | 7.74                             | 13  | PASS             |
| 4              | 5240                           | 6.58                             | 13  | PASS             |
| 5              | 5260                           | 8.78                             | 13  | PASS             |
| 8              | 5320                           | 7.36                             | 13  | PASS             |



CHANNEL 1

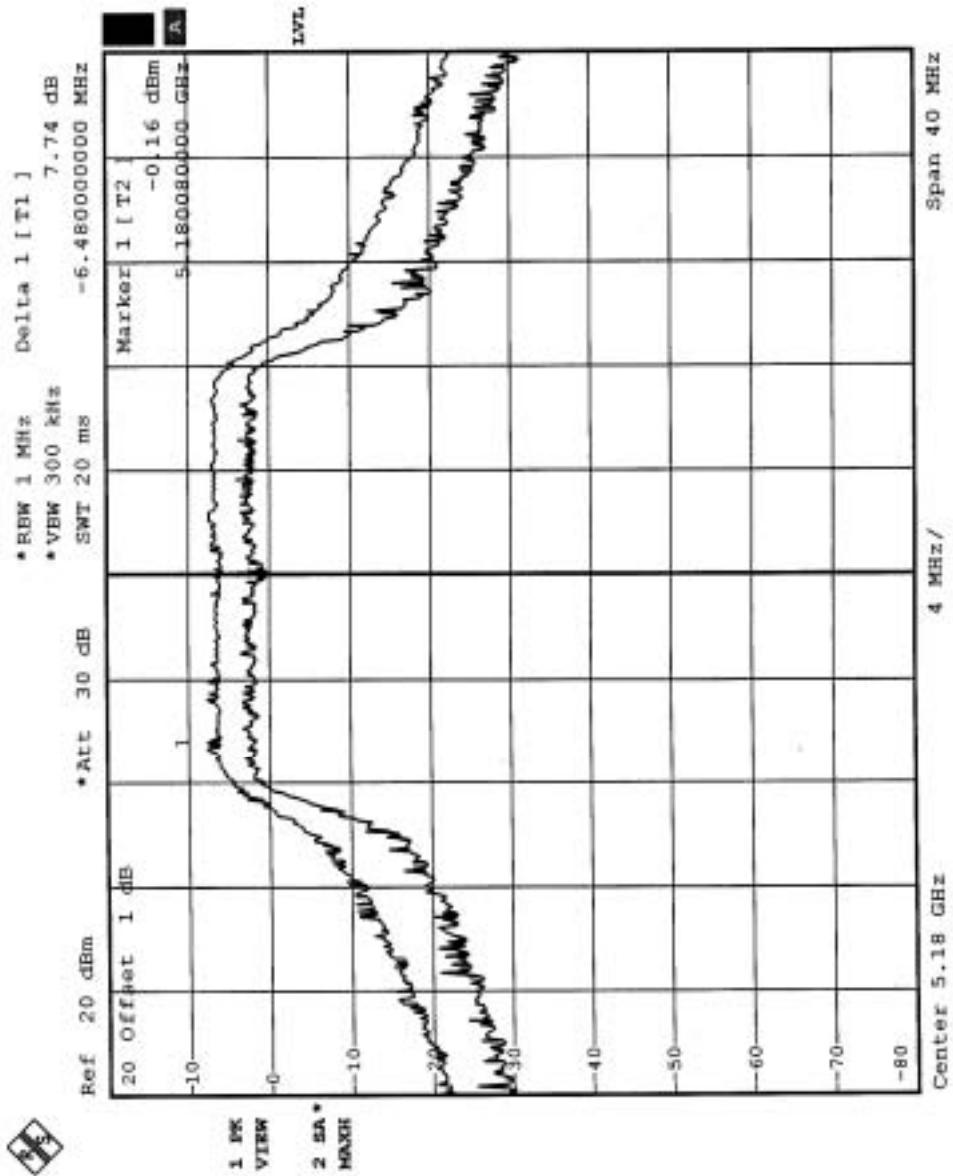



CHANNEL 4

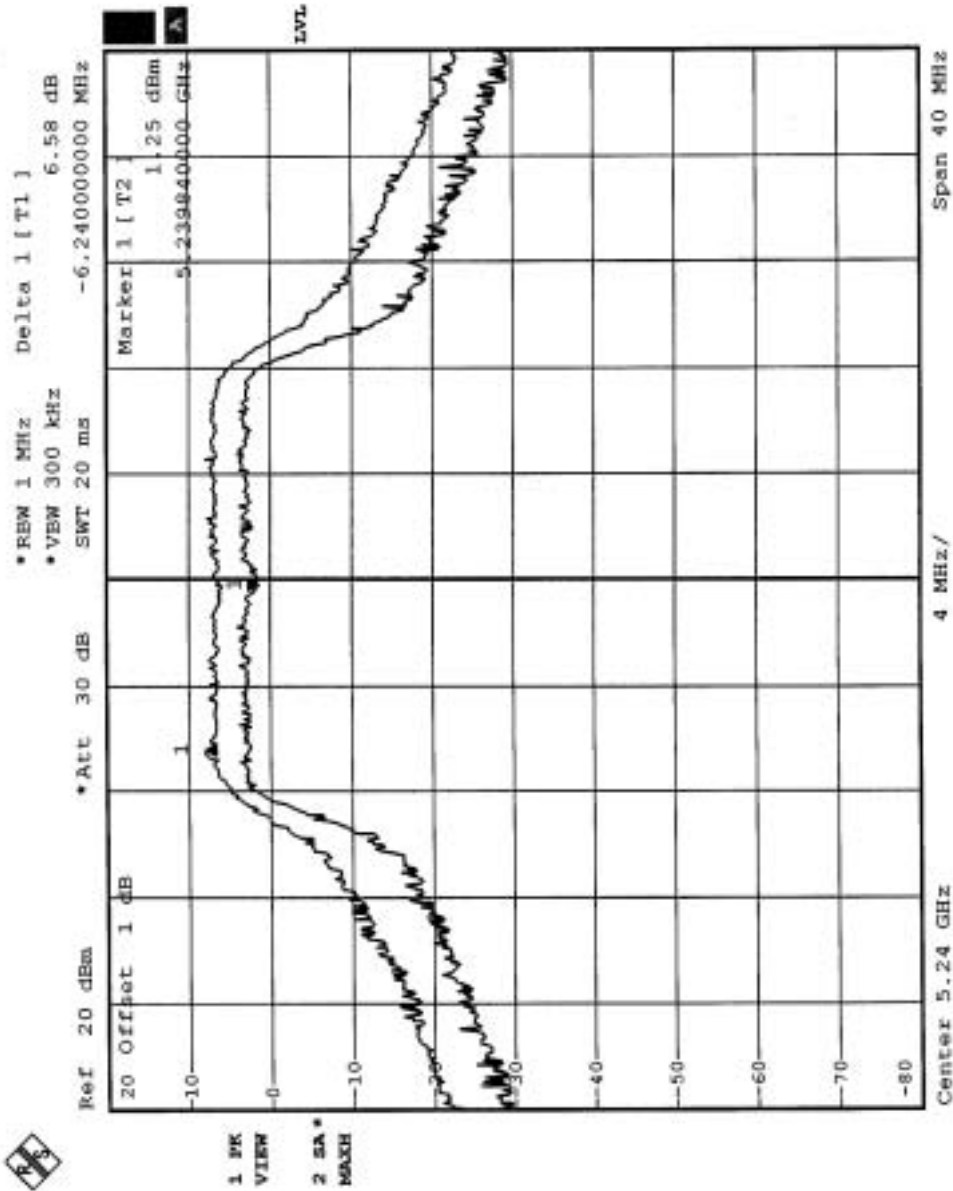



CHANNEL 5

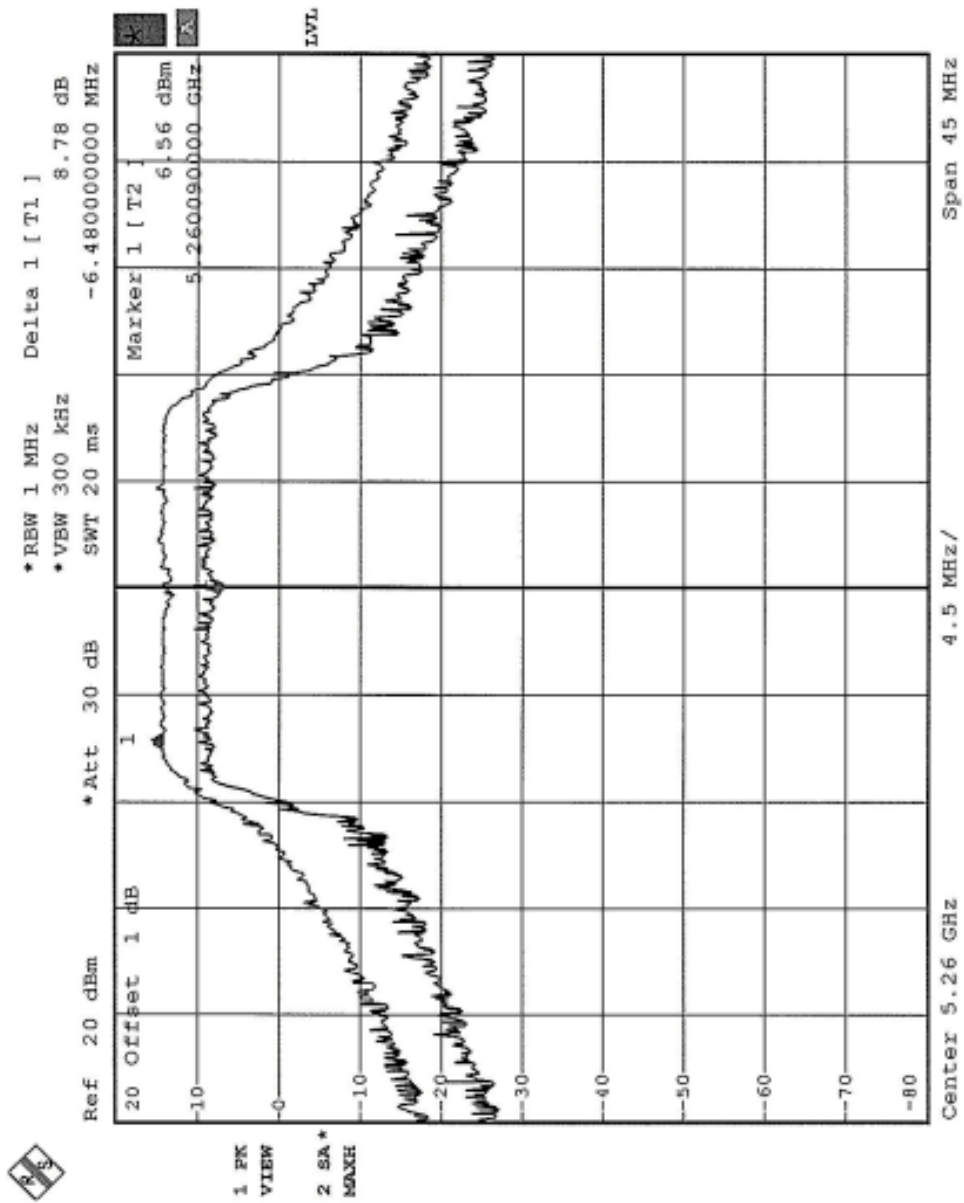



CHANNEL 8

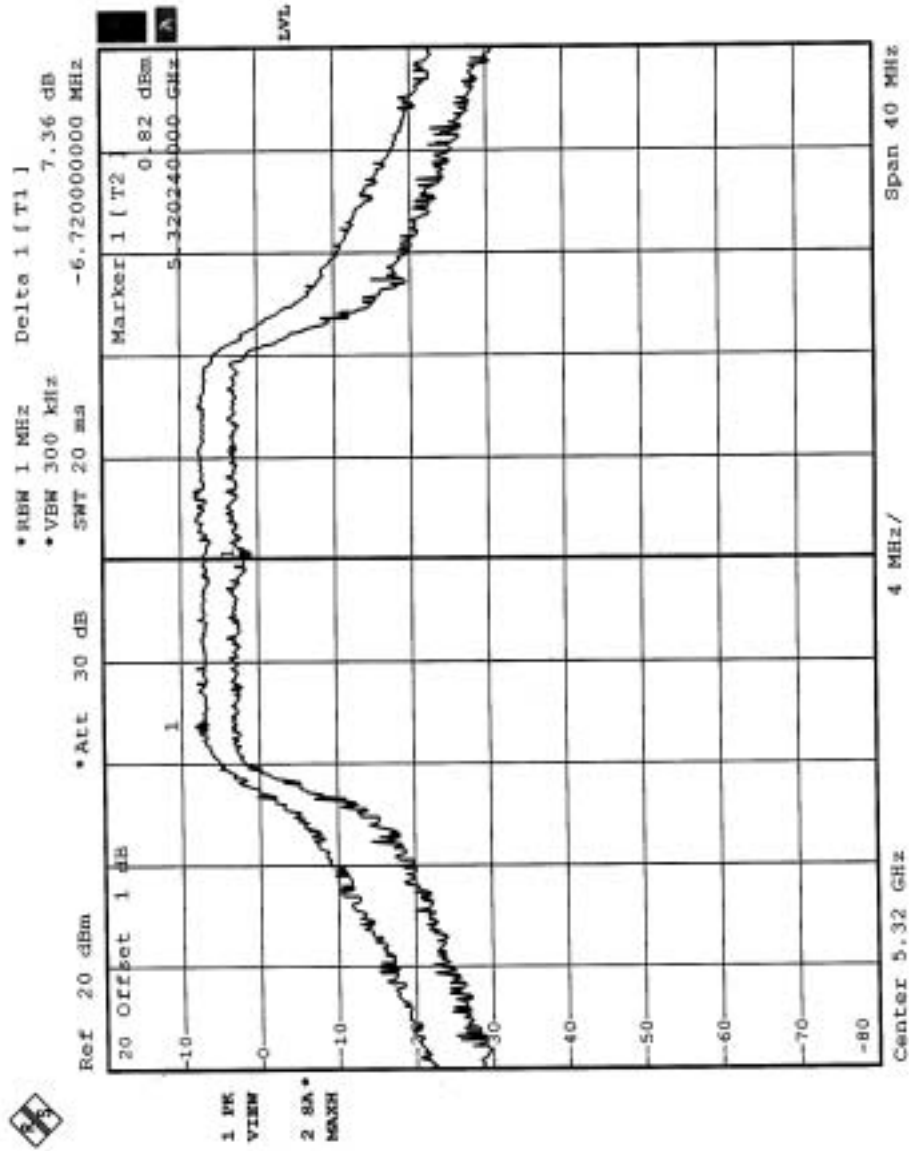





|                                 |  |                             |               |
|---------------------------------|--|-----------------------------|---------------|
| <b>EUT</b>                      | Wireless Dual Band Enterprise Access Point | <b>MODEL</b>                | RBT3K-AG      |
| <b>MODE</b>                     | Turbo                                      | <b>INPUT POWER (SYSTEM)</b> | 120Vac, 60 Hz |
| <b>ENVIRONMENTAL CONDITIONS</b> | 21eg. C, 58RH, 974 hPa                     | <b>TESTED BY</b>            | Eric Lee      |

| <b>CHANNEL</b> | <b>CHANNEL FREQUENCY (MHz)</b> | <b>PEAK POWER EXCURSION (dB)</b> | <b>PEAK to AVERAGE EXCURSION LIMIT (dB)</b> | <b>PASS/FAIL</b> |
|----------------|--------------------------------|----------------------------------|---|------------------|
| 1              | 5210                           | 8.88                             | 13  | PASS             |
| 2              | 5250                           | 8.73                             | 13  | PASS             |
| 3              | 5290                           | 7.32                             | 13  | PASS             |



CHANNEL 1

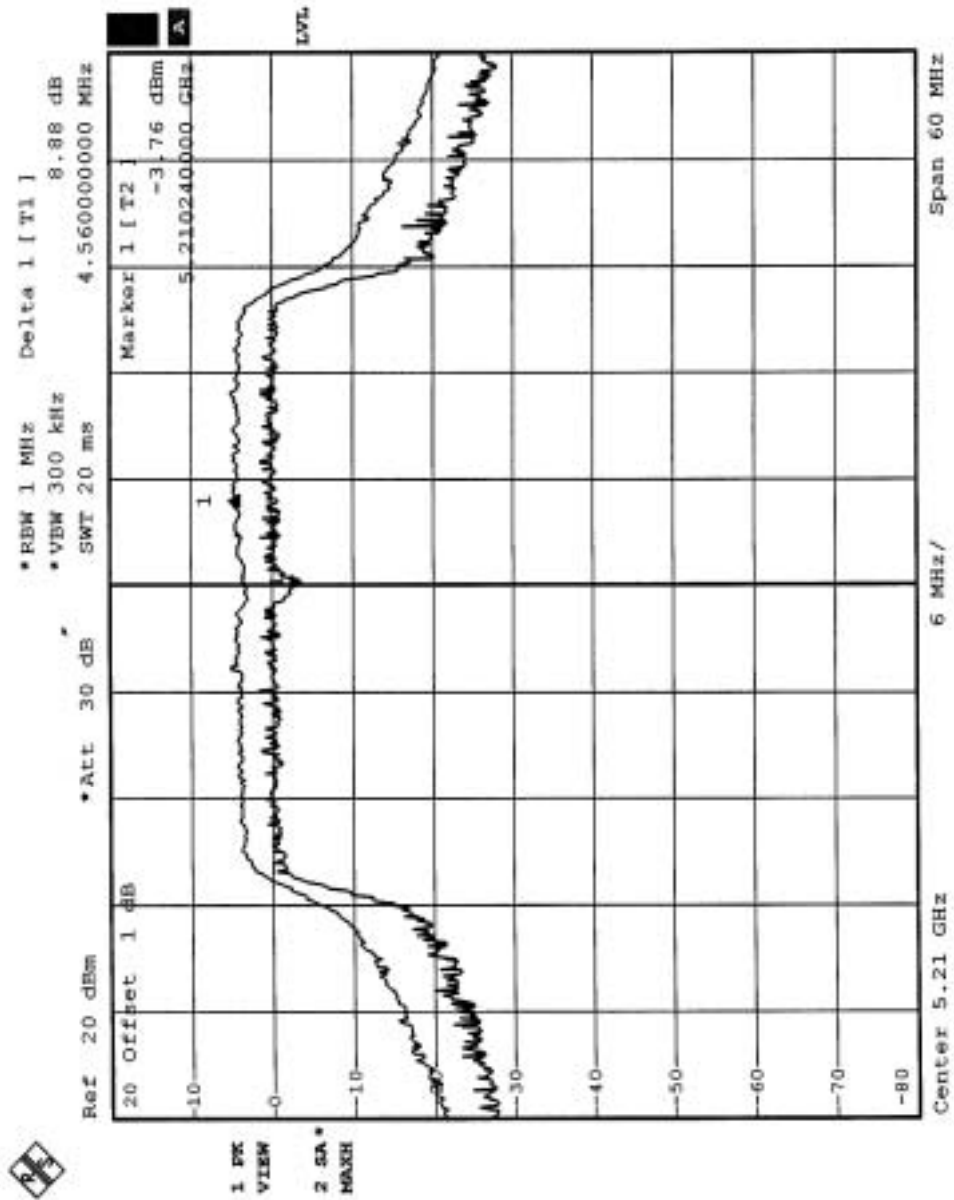



CHANNEL 2

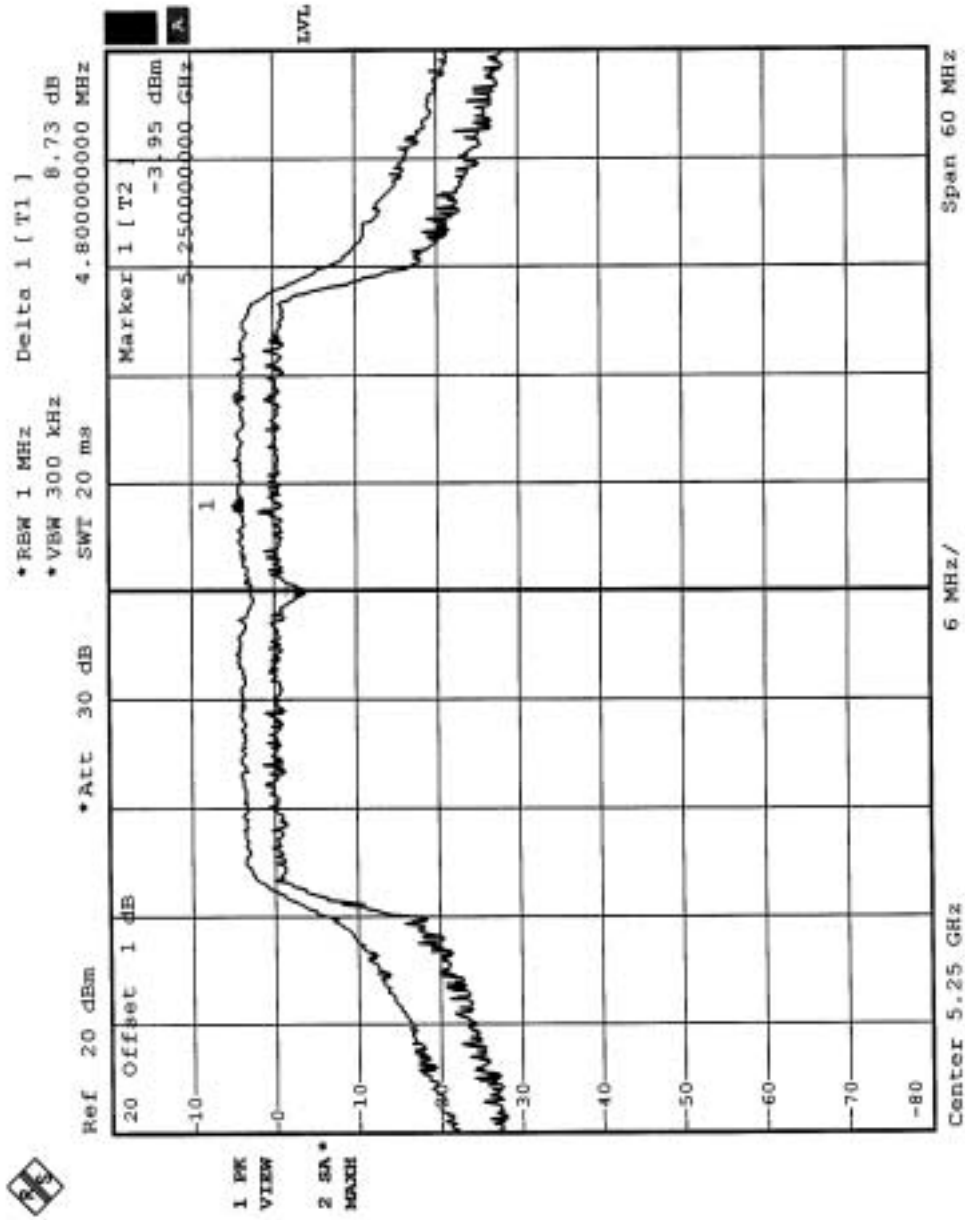



CHANNEL 3

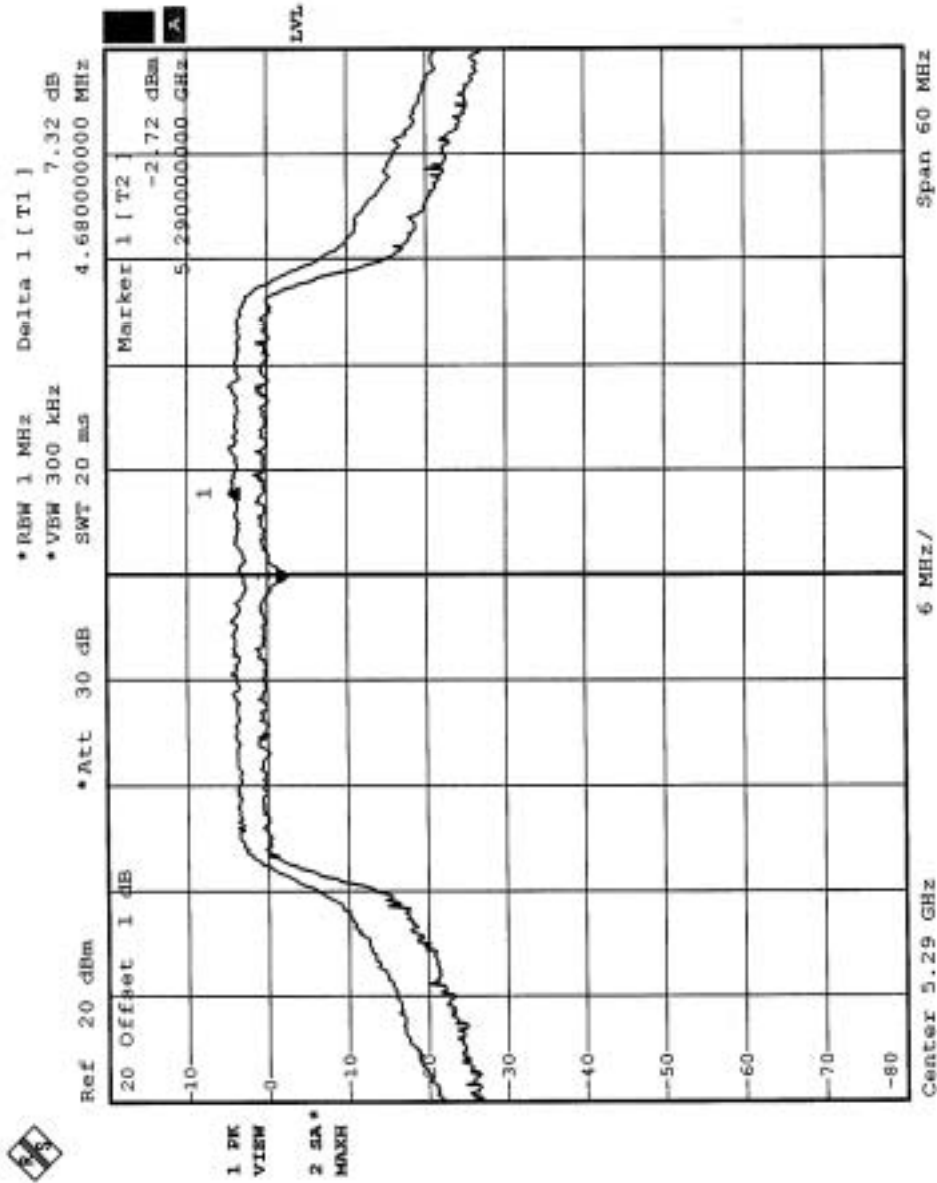



## 5.5 PEAK POWER SPECTRAL DENSITY MEASUREMENT

### 5.5.1 LIMITS OF PEAK POWER SPECTRAL DENSITY MEASUREMENT

| Frequency Band    | Limit |
|-------------------|-------|
| 5.15 – 5.25 GHz   | 4dBm  |
| 5.25 – 5.35 GHz   | 11dBm |
| 5.725 – 5.825 GHz | 17dBm |

### 5.5.2 TEST INSTRUMENTS

| Description & Manufacturer | Model No. | Serial No. | Calibrated Until |
|----------------------------|-----------|------------|------------------|
| R&S SPECTRUM ANALYZER      | FSP30     | 100019     | Dec. 19, 2003    |

**NOTE:**

The calibration interval of the above test instruments is 12 months and the calibrations are traceable to NML/ROC and NIST/USA.



### 5.5.3 TEST PROCEDURES

1. The transmitter output was connected to the spectrum analyzer.
2. Set RBW=1MHz, VBW=3MHz. The PPSD is the highest level found across the emission in any 1MHz band.

### 5.5.4 DEVIATION FROM TEST STANDARD

No deviation

### 5.5.5 TEST SETUP



### 5.5.6 EUT OPERATING CONDITIONS

Same as 5.3.6



## 5.5.7 TEST RESULTS

|                                 |  |                             |               |
|---------------------------------|--|-----------------------------|---------------|
| <b>EUT</b>                      | Wireless Dual Band Enterprise Access Point | <b>MODEL</b>                | RBT3K-AG      |
| <b>MODE</b>                     | Normal                                     | <b>INPUT POWER (SYSTEM)</b> | 120Vac, 60 Hz |
| <b>ENVIRONMENTAL CONDITIONS</b> | 21eg. C, 58RH, 974 hPa                     | <b>TESTED BY</b>            | Eric Lee      |

| <b>CHANNEL NUMBER</b> | <b>CHANNEL FREQUENCY (MHz )</b> | <b>RF POWER LEVEL IN 1 MHz BW (dBm)</b> | <b>MAXIMUM LIMIT (dBm)</b> | <b>PASS/FAIL</b> |
|-----------------------|---------------------------------|---|----------------------------|------------------|
| 1                     | 5180                            | -1.12                                   | 4                          | PASS             |
| 4                     | 5240                            | -0.84                                   | 4                          | PASS             |
| 5                     | 5260                            | 3.93                                    | 11                         | PASS             |
| 8                     | 5320                            | -0.23                                   | 11                         | PASS             |



CHANNEL 1

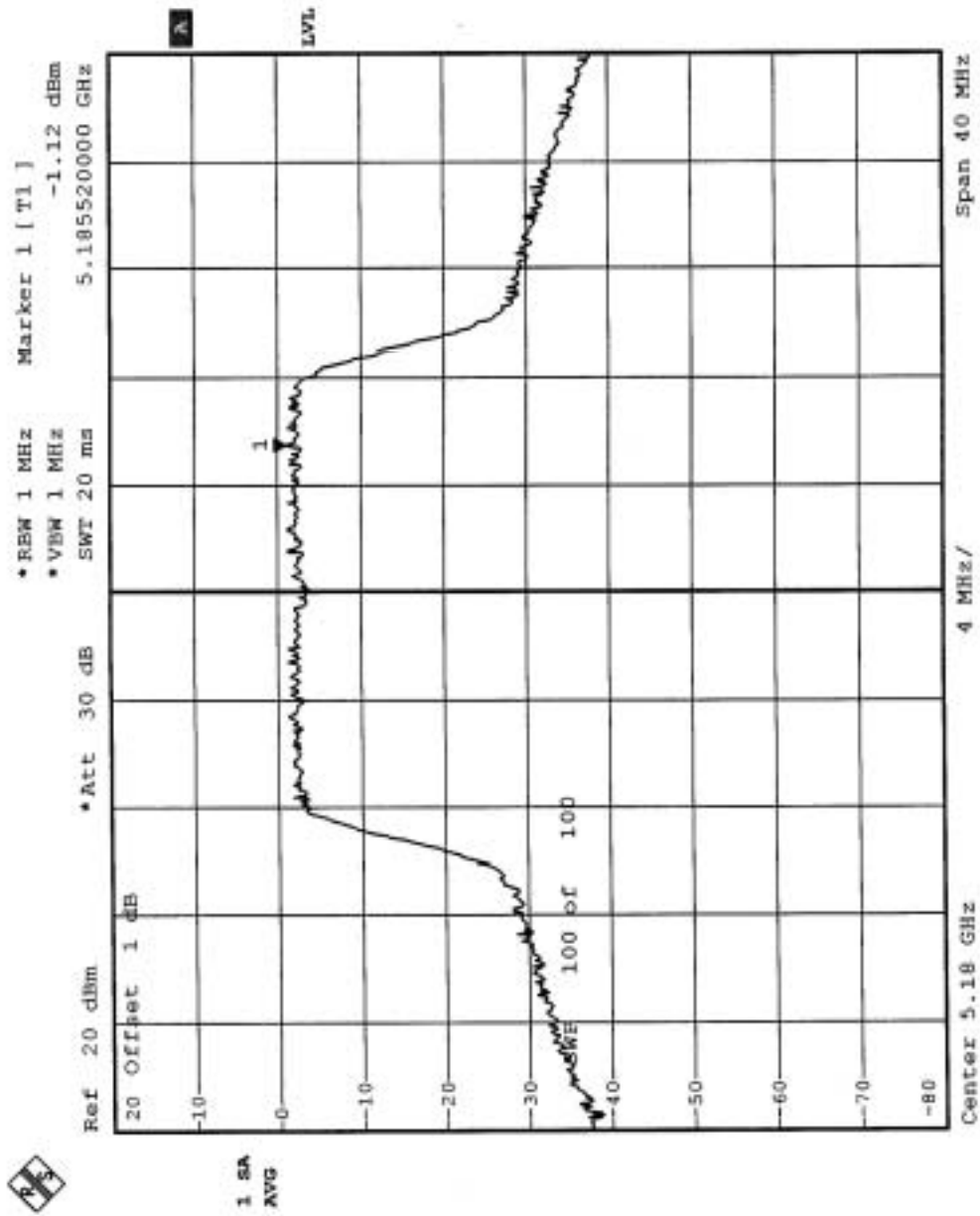





CHANNEL 4

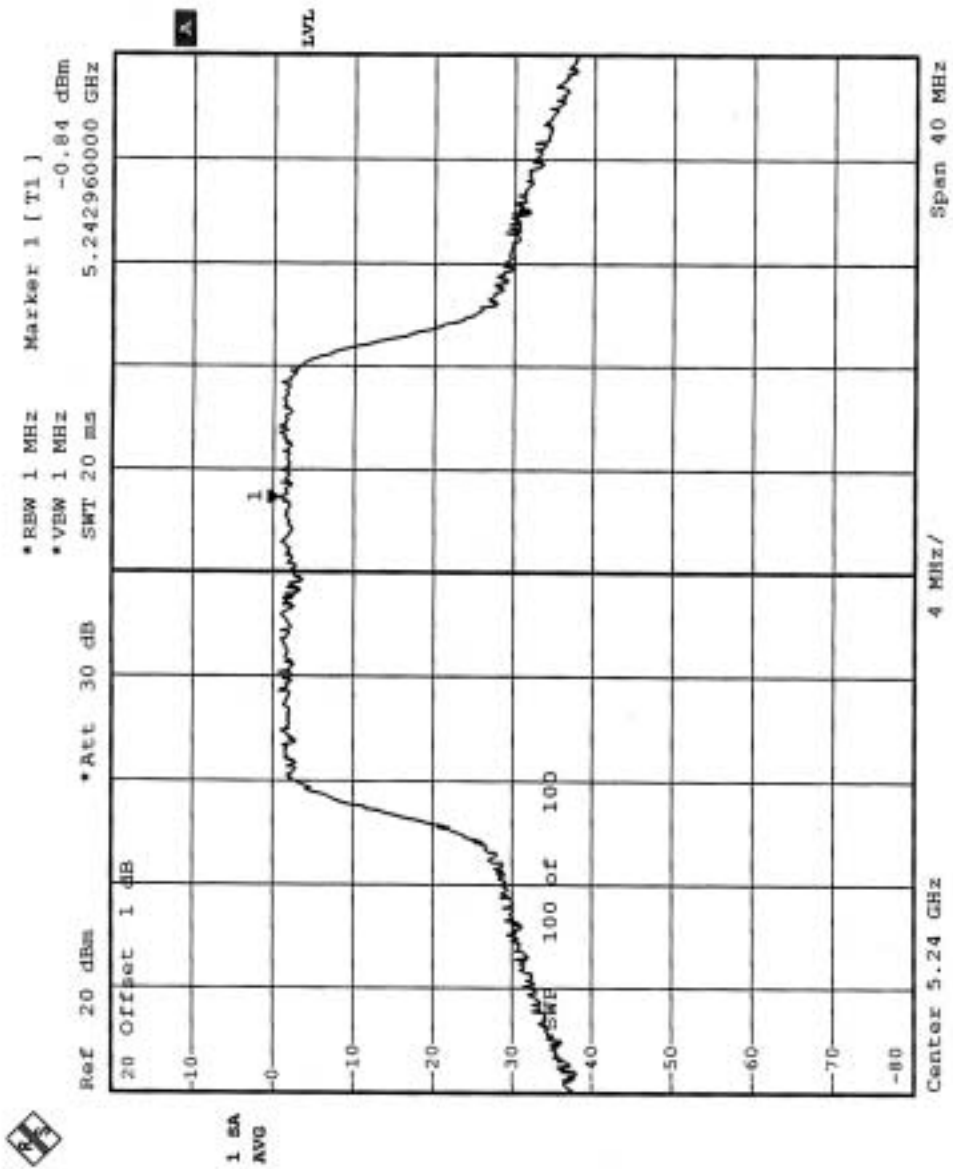



CHANNEL 5

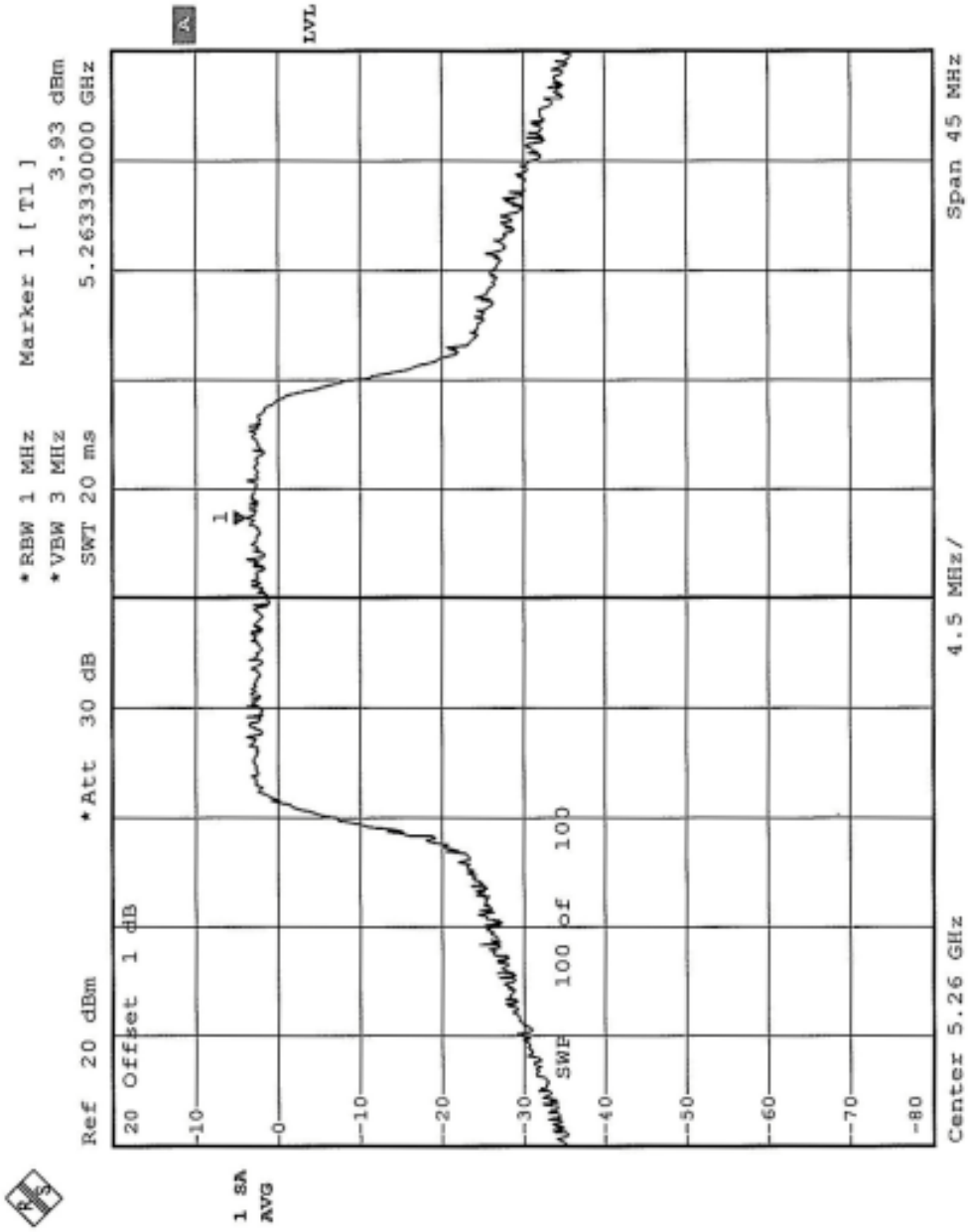



CHANNEL 8

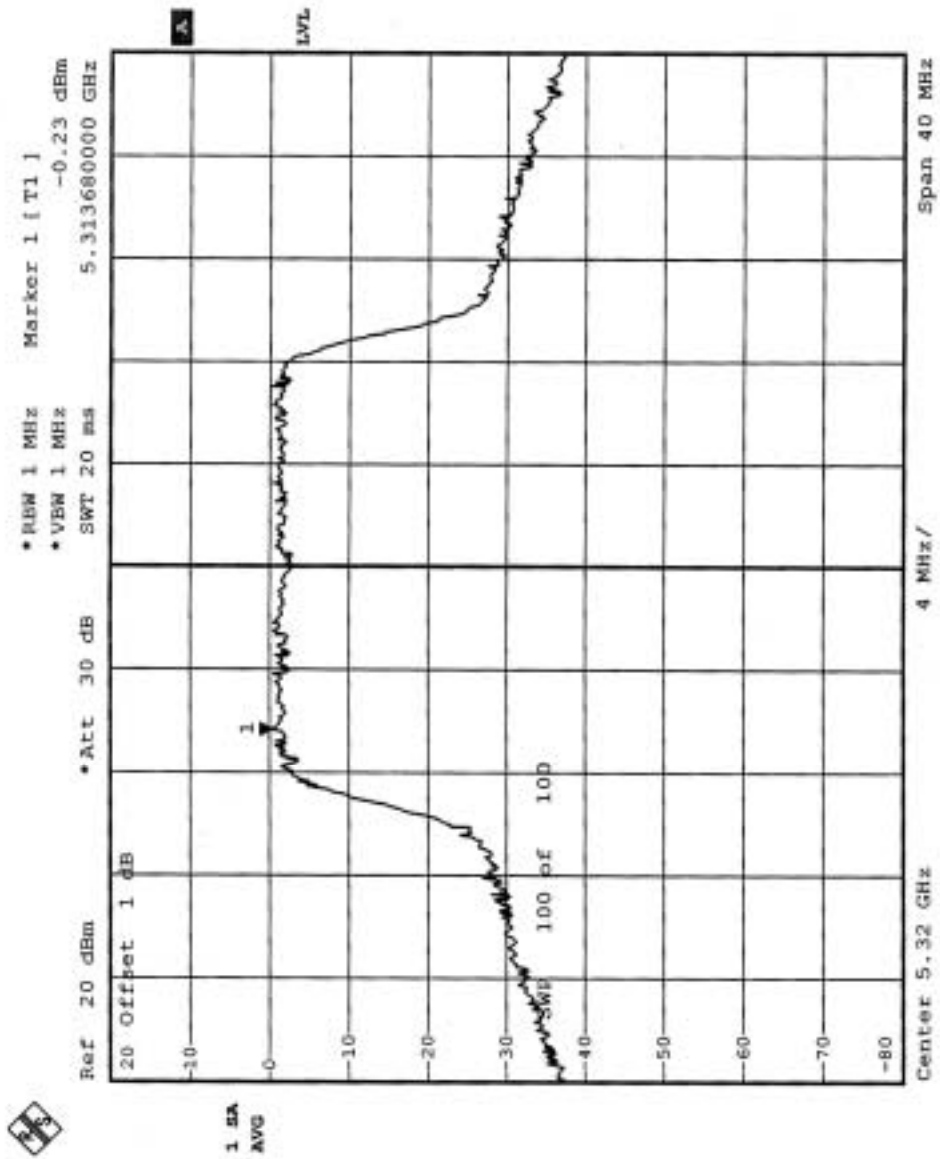



|                                 |  |                             |               |
|---------------------------------|--|-----------------------------|---------------|
| <b>EUT</b>                      | Wireless Dual Band Enterprise Access Point | <b>MODEL</b>                | RBT3K-AG      |
| <b>MODE</b>                     | Turbo                                      | <b>INPUT POWER (SYSTEM)</b> | 120Vac, 60 Hz |
| <b>ENVIRONMENTAL CONDITIONS</b> | 21eg. C, 58RH, 974 hPa                     | <b>TESTED BY</b>            | Eric Lee      |

| <b>CHANNEL NUMBER</b> | <b>CHANNEL FREQUENCY (MHz)</b> | <b>RF POWER LEVEL IN 1 MHz BW (dBm)</b> | <b>MAXIMUM LIMIT (dBm)</b> | <b>PASS/FAIL</b> |
|-----------------------|--------------------------------|---|----------------------------|------------------|
| 1                     | 5210                           | -4.93                                   | 4                          | PASS             |
| 2                     | 5250                           | -3.70                                   | 4                          | PASS             |
| 3                     | 5290                           | -3.81                                   | 11                         | PASS             |



CHANNEL 1

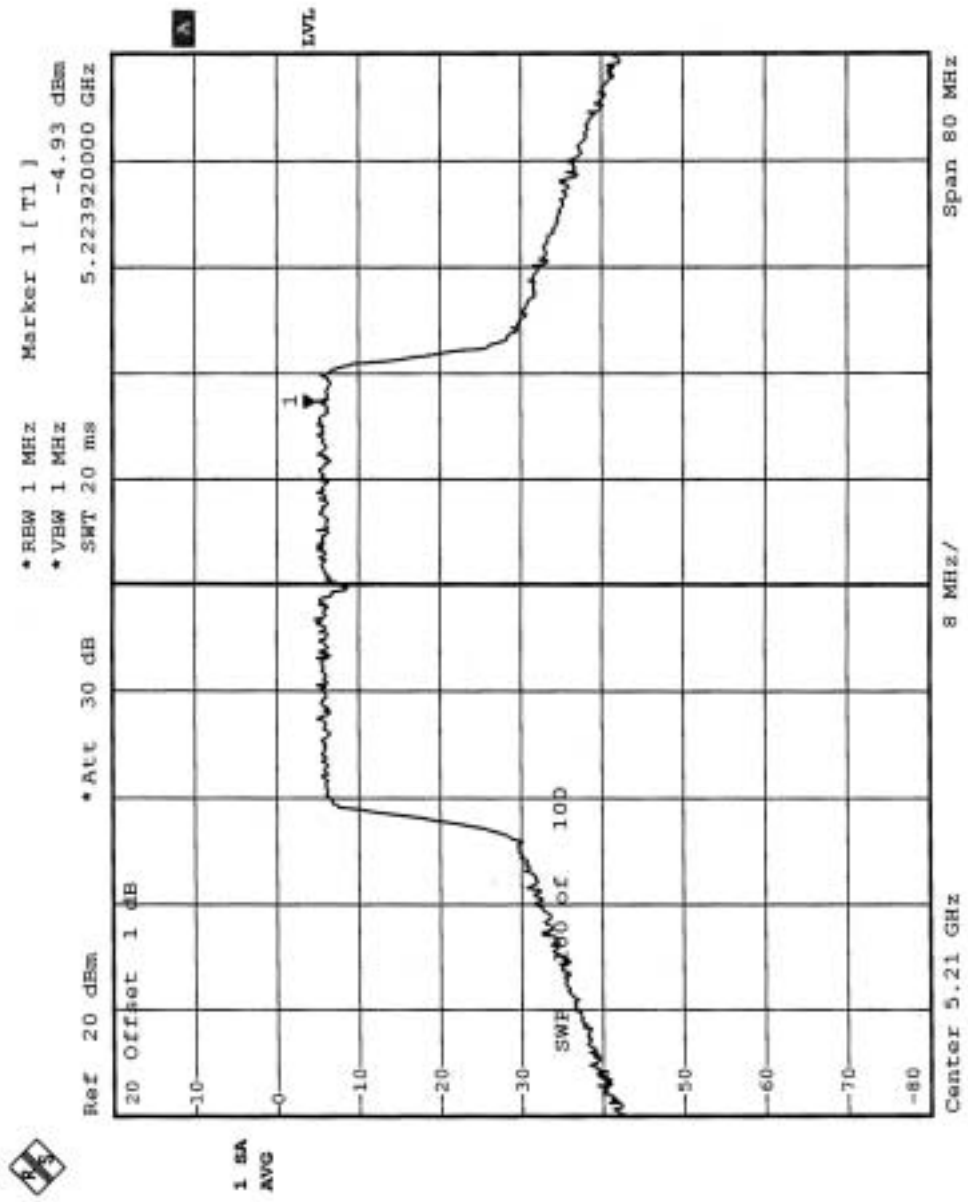



CHANNEL 2

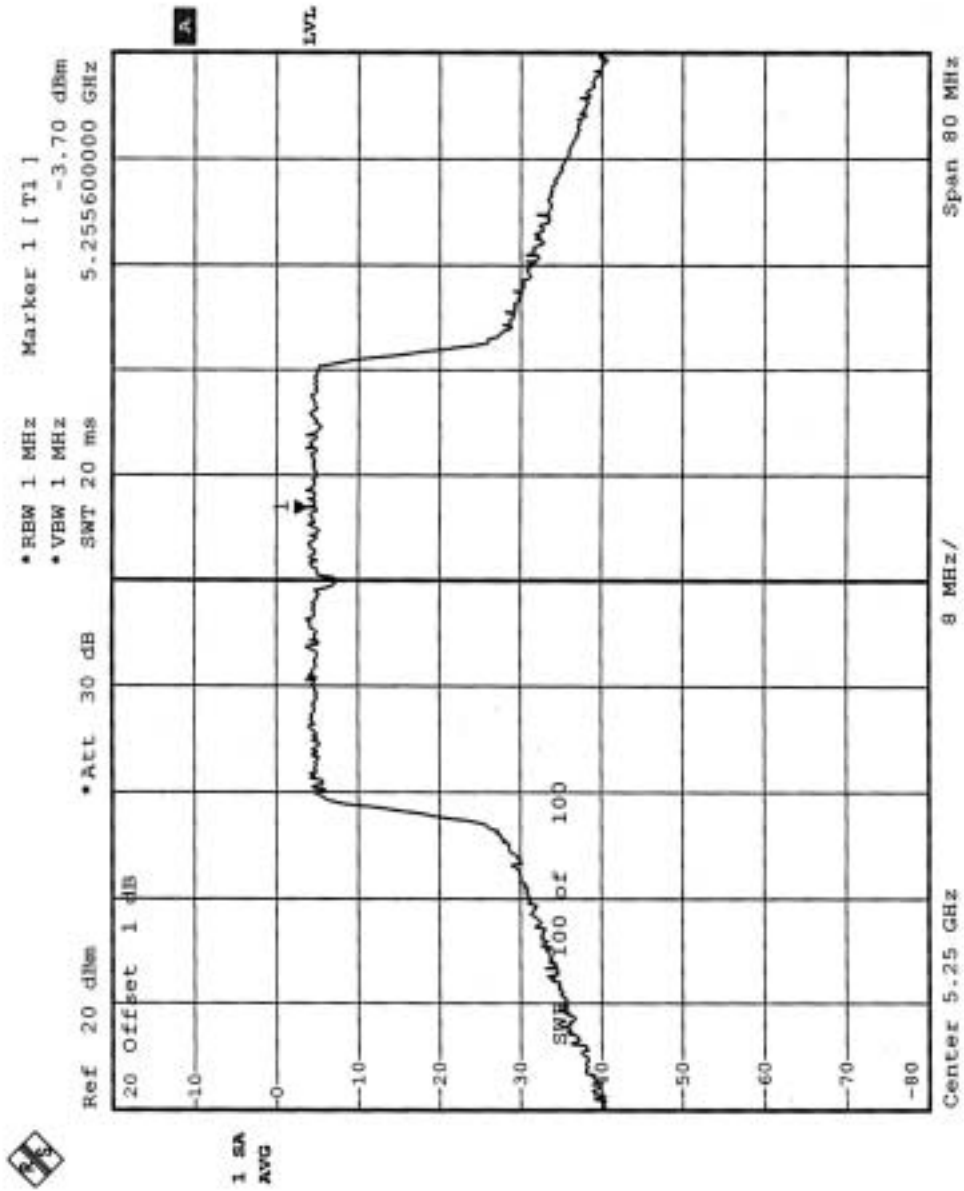



CHANNEL 3

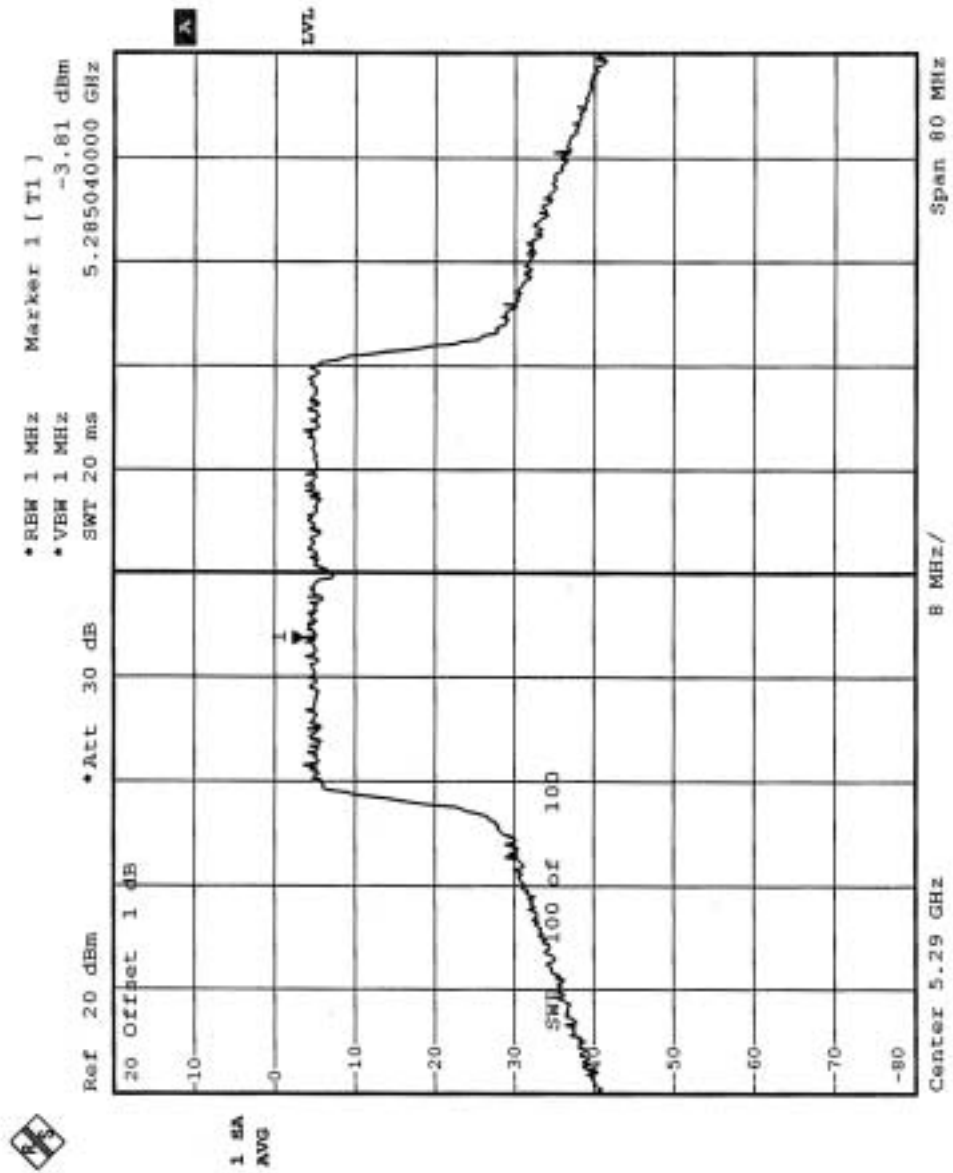



## 5.6 FREQUENCY STABILITY

### 5.6.1 LIMITS OF FREQUENCY STABILITY MEASUREMENT

The frequency tolerance of the carrier signal shall be maintained within +/- 0.02% of the operating frequency over a temperature variation of -30 degrees to 50 degrees C at normal supply voltage, and for a variation in the primary supply voltage from 85% to 115% of the rated supply voltage at a temperature of 20 degrees C.

### 5.6.2 TEST INSTRUMENTS

| Description & Manufacturer | Model No. | Serial No. | Calibrated Until |
|----------------------------|-----------|------------|------------------|
| R&S SPECTRUM ANALYZER      | FSP30     | 100019     | Dec. 19, 2003    |

**NOTE:**

The calibration interval of the above test instruments is 12 months and the calibrations are traceable to NML/ROC and NIST/USA.

### 5.6.3 TEST PROCEDURE

1. The EUT was placed inside the environmental test chamber and powered by nominal AC voltage.
2. Turn the EUT on and couple its output to a spectrum analyzer.
3. Turn the EUT off and set the chamber to the highest temperature specified.
4. Allow sufficient time (approximately 30 min) for the temperature of the chamber to stabilize, turn the EUT on and measure the operating frequency after 2, 5, and 10 minutes.
5. Repeat step 2 and 3 with the temperature chamber set to the lowest temperature.
6. The test chamber was allowed to stabilize at +20 degree C for a minimum of 30 minutes. The supply voltage was then adjusted on the EUT from 85% to 115% and the frequency record.

### 5.6.4 DEVIATION FROM TEST STANDARD

No deviation



### 5.6.5 TEST SETUP

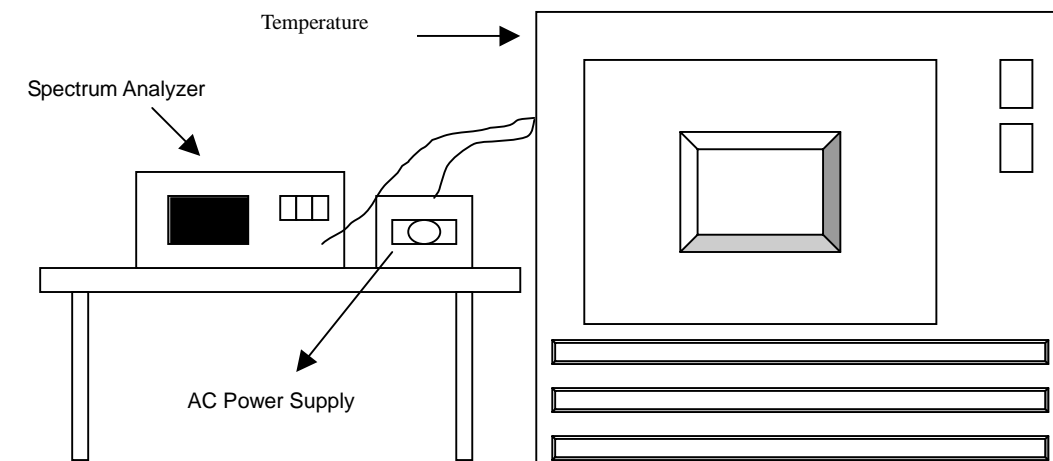

### 5.6.6 EUT OPERATING CONDITION

Same as Item 4.1.6



5.6.7 TEST RESULTS

|              |                       | Operating frequency: 5320MHz |            |           |            | Limit : ± 0.02% |            |
|--------------|-----------------------|------------------------------|------------|-----------|------------|-----------------|------------|
| Temp.<br>( ) | Power supply<br>(VAC) | 2 minute                     |            | 5 minute  |            | 10 minute       |            |
|              |                       | (MHz)                        | (%)        | (MHz)     | (%)        | (MHz)           | (%)        |
| 50           | 126.5                 | 5320.0167                    | 0.000314%  | 5320.0167 | 0.000314%  | 5320.0168       | 0.000316%  |
|              | 110.0                 | 5320.0168                    | 0.000316%  | 5320.0169 | 0.000318%  | 5320.0168       | 0.000316%  |
|              | 93.5                  | 5320.0166                    | 0.000312%  | 5320.017  | 0.000320%  | 5320.0168       | 0.000316%  |
| 40           | 126.5                 | 5319.9974                    | -0.000049% | 5319.9979 | -0.000039% | 5319.9978       | -0.000041% |
|              | 110.0                 | 5319.9976                    | -0.000045% | 5319.9977 | -0.000043% | 5319.9979       | -0.000039% |
|              | 93.5                  | 5319.9975                    | -0.000047% | 5319.9978 | -0.000041% | 5319.9978       | -0.000041% |
| 30           | 126.5                 | 5319.9932                    | -0.000128% | 5319.9935 | -0.000122% | 5319.9934       | -0.000124% |
|              | 110.0                 | 5319.9932                    | -0.000128% | 5319.9934 | -0.000124% | 5319.9936       | -0.000120% |
|              | 93.5                  | 5319.9932                    | -0.000128% | 5319.9936 | -0.000120% | 5319.9937       | -0.000118% |
| 20           | 126.5                 | 5319.9955                    | -0.000085% | 5319.9955 | -0.000085% | 5319.9955       | -0.000085% |
|              | 110.0                 | 5319.9952                    | -0.000090% | 5319.9953 | -0.000088% | 5319.9953       | -0.000088% |
|              | 93.5                  | 5319.9955                    | -0.000085% | 5319.9956 | -0.000083% | 5319.9954       | -0.000086% |
| 10           | 126.5                 | 5319.9934                    | -0.000124% | 5319.9936 | -0.000120% | 5319.9938       | -0.000117% |
|              | 110.0                 | 5319.9932                    | -0.000128% | 5319.9935 | -0.000122% | 5319.9938       | -0.000117% |
|              | 93.5                  | 5319.9935                    | -0.000122% | 5319.9935 | -0.000122% | 5319.9937       | -0.000118% |
| 0            | 126.5                 | 5319.9945                    | -0.000103% | 5319.9945 | -0.000103% | 5319.9946       | -0.000102% |
|              | 110.0                 | 5319.9944                    | -0.000105% | 5319.9946 | -0.000102% | 5319.9947       | -0.000100% |
|              | 93.5                  | 5319.9944                    | -0.000105% | 5319.9944 | -0.000105% | 5319.9947       | -0.000100% |
| -10          | 126.5                 | 5320.0039                    | 0.000073%  | 5320.0041 | 0.000077%  | 5320.0043       | 0.000081%  |
|              | 110.0                 | 5320.004                     | 0.000075%  | 5320.0042 | 0.000079%  | 5320.0043       | 0.000081%  |
|              | 93.5                  | 5320.0041                    | 0.000077%  | 5320.0042 | 0.000079%  | 5320.0043       | 0.000081%  |
| -20          | 126.5                 | 5320.0185                    | 0.000348%  | 5320.0184 | 0.000346%  | 5320.0186       | 0.000350%  |
|              | 110.0                 | 5320.0184                    | 0.000346%  | 5320.0185 | 0.000348%  | 5320.0186       | 0.000350%  |
|              | 93.5                  | 5320.0185                    | 0.000348%  | 5320.0186 | 0.000350%  | 5320.0186       | 0.000350%  |
| -30          | 126.5                 | 5320.019                     | 0.000357%  | 5320.0210 | 0.000395%  | 5320.0220       | 0.000414%  |
|              | 110.0                 | 5320.02                      | 0.000376%  | 5320.0220 | 0.000414%  | 5320.0210       | 0.000395%  |
|              | 93.5                  | 5320.019                     | 0.000357%  | 5320.0220 | 0.000414%  | 5320.0220       | 0.000414%  |



## 5.7 BAND EDGES MEASUREMENT

### 5.7.1 TEST INSTRUMENTS

| Description & Manufacturer | Model No. | Serial No.   | Calibrated Until |
|----------------------------|-----------|--------------|------------------|
| R&S SPECTRUM ANALYZER      | FSP       | 1093.4495.30 | Dec. 19, 2003    |

**NOTE:**

- 1.The measurement uncertainty is less than +/- 2.6dB, which is calculated as per the NAMAS document NIS81.
- 2.The calibration interval of the above test instruments is 12 months and the calibrations are traceable to NML/ROC and NIST/USA.

### 5.7.2 TEST PROCEDURE

The transmitter output was connected to the spectrum analyzer via a low lose cable. Set RBW of spectrum analyzer to 1MHz and VBW of spectrum analyzer to 300Hz with suitable frequency span including 100 MHz bandwidth from band edge. The band edges was measured and recorded.

### 5.7.3 EUT OPERATING CONDITION

The software provided by client to enable the EUT under transmission condition continuously at specific channel frequencies individually.



#### 5.7.4 TEST RESULTS

For signals in the restricted bands above and below the 5.15 to 5.35 GHz allocated band a measurement was made of the amplitude of the spurious emissions with respect to the intentional signals. The relative amplitude, in dBc, was applied to the average and peak field strength of the intentional signal made on the OATS to calculate the field strength of the unintentional signals.

The spectrum plots (Average RBW=1MHz, VBW=300Hz) are attached on the following 4 pages.



Normal Mode: Channel 1 (5180 MHz)

The band edge emission plot on the following page shows 45.07dBc (Average) between carrier maximum power and local maximum emission in restrict band. The emission of carrier strength list in the test result of channel 1 (normal mode) is 95.7dBuV/m, so the maximum field strength in restrict band is  $95.7-45.07=50.63$ dBuV/m which is under 54dBuV/m limit.

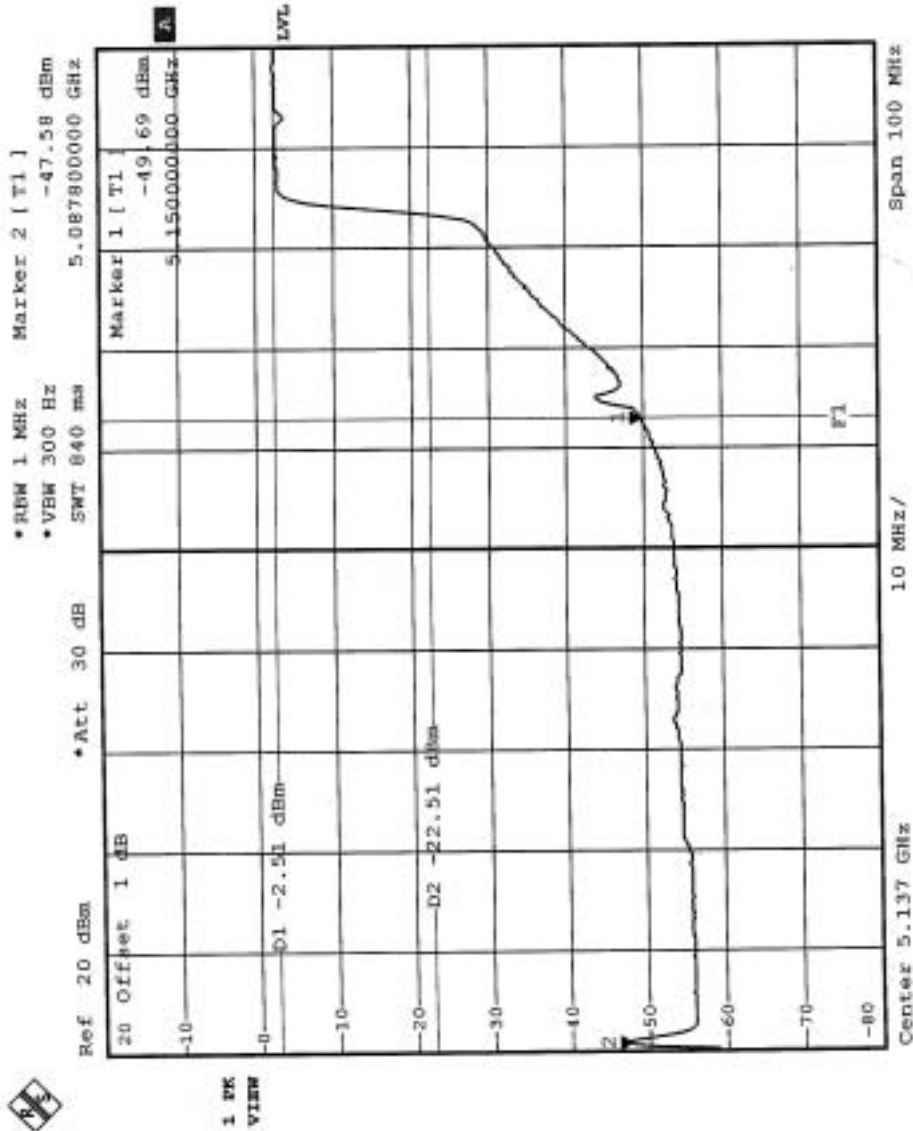



Normal Mode: Channel 8 (5320 MHz)

The band edge emission plot on the following page shows 41.18dBc (Average) between carrier maximum power and local maximum emission in restrict band. The emission of carrier strength list in the test result of channel 8 (normal mode) is 94.0dBuV/m, so the maximum field strength in restrict band is  $94.0-41.18=52.82\text{dBuV/m}$  which is under 54dBuV/m limit.

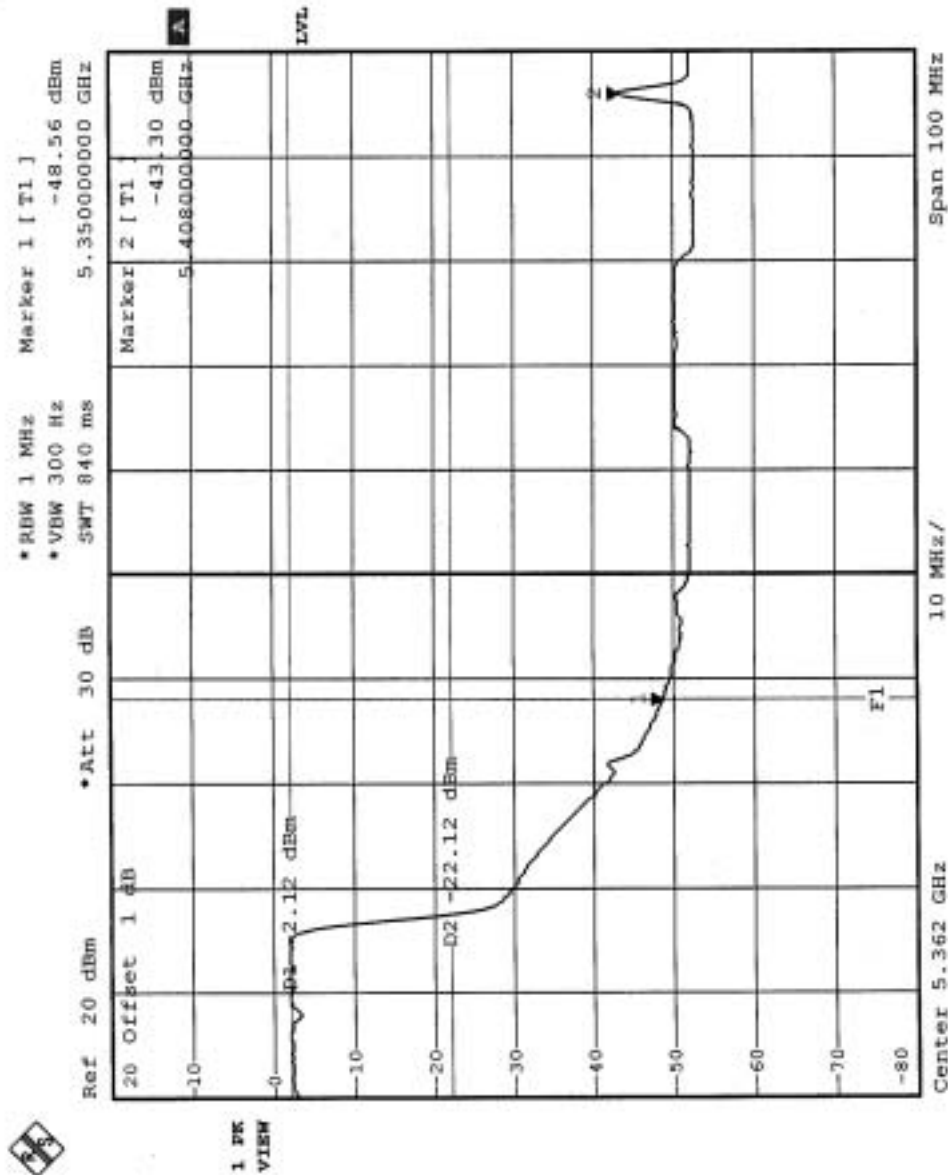



Turbo Mode: Channel 1 (5210 MHz)

The band edge emission plot on the following page shows 41.82dBc (Average) between carrier maximum power and local maximum emission in restrict band. The emission of carrier strength list in the test result of channel 1 (turbo mode) is 92.2dBuV/m, so the maximum field strength in restrict band is  $92.2 - 41.82 = 50.38$  dBuV/m which is under 54dBuV/m limit.

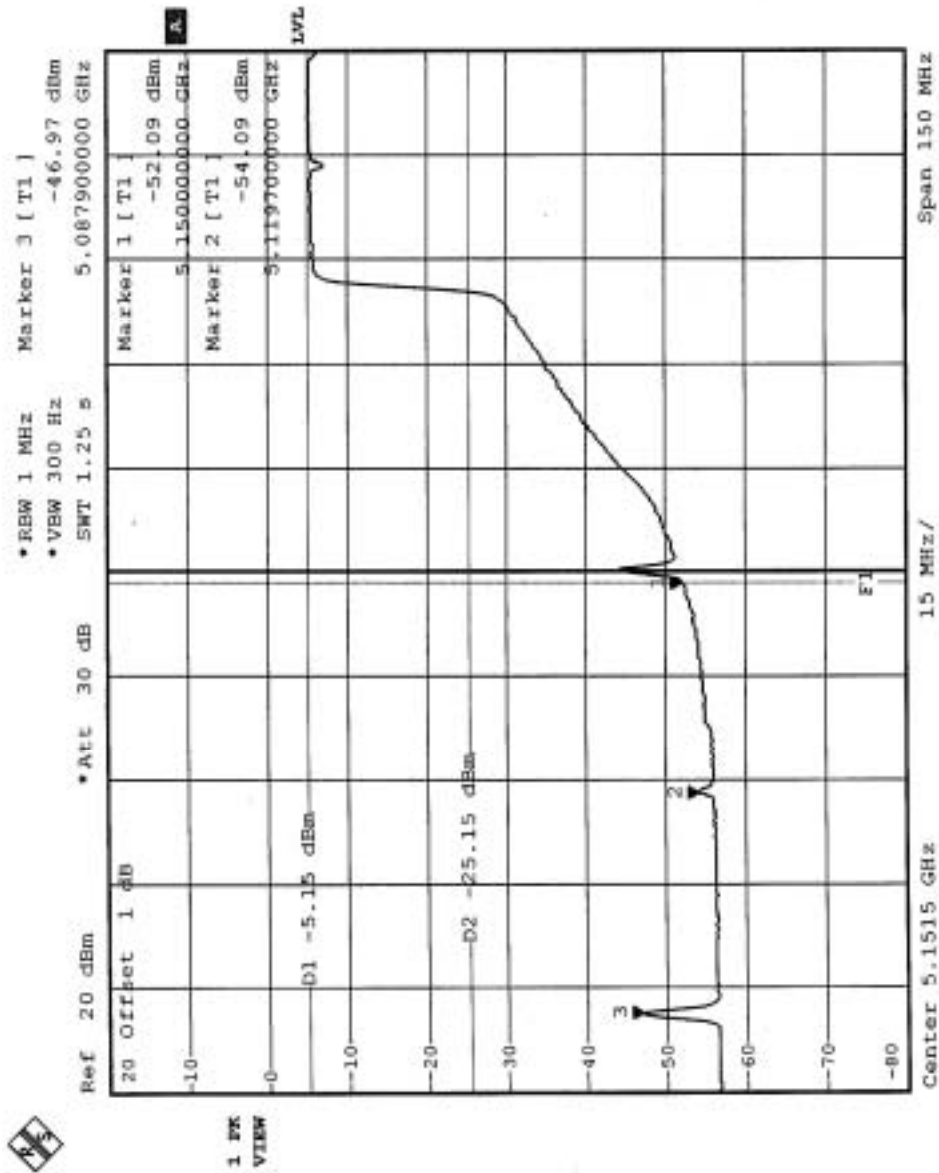



Turbo Mode: Channel 3 (5290 MHz)

The band edge emission plot on the following page shows 38.38dBc (Average) between carrier maximum power and local maximum emission in restrict band. The emission of carrier strength list in the test result of channel 8 (turbo mode) is 91.2dBuV/m, so the maximum field strength in restrict band is  $91.2 - 38.38 = 52.82$  dBuV/m which is under 54dBuV/m limit.

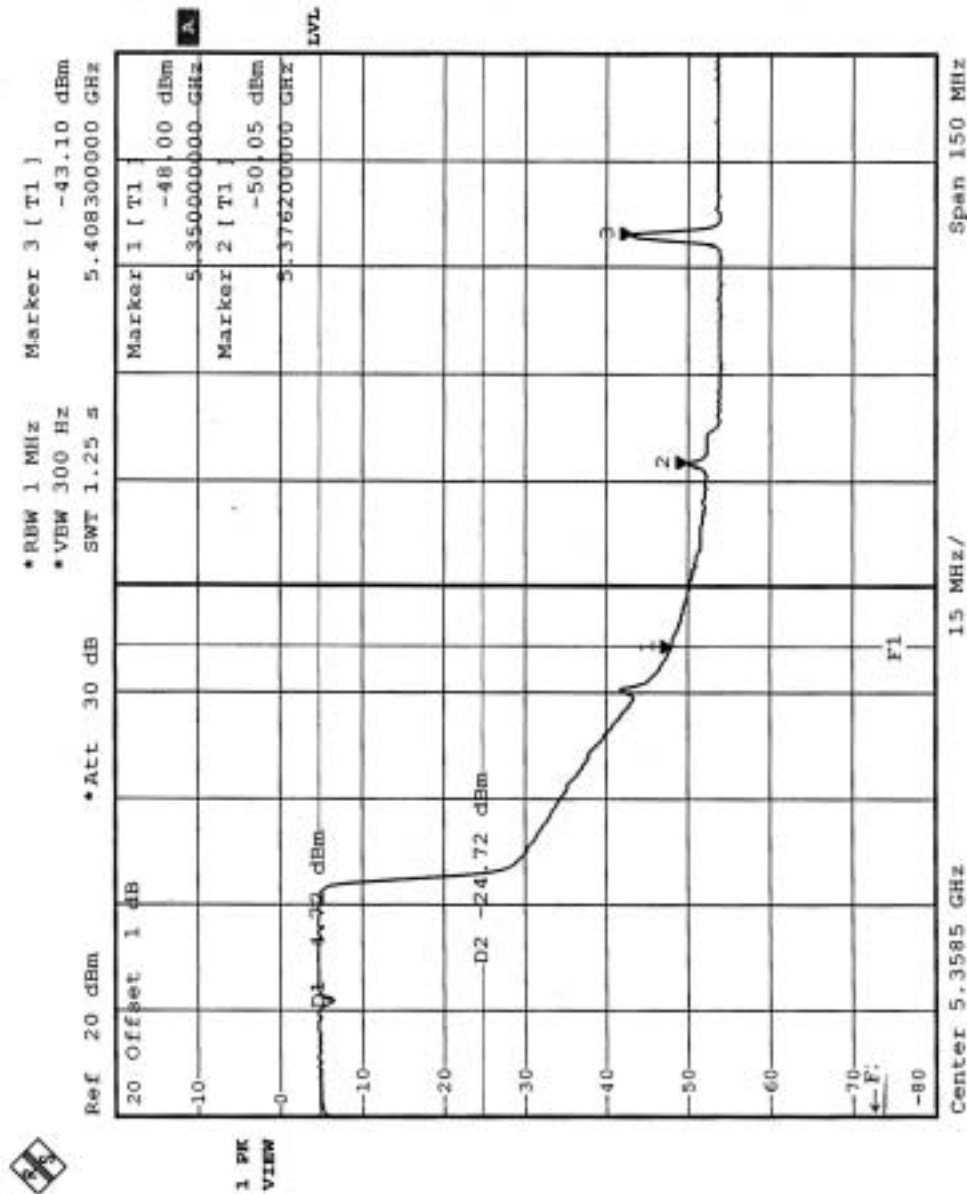



**FOR FREQUENCY 5.725~5.850GHz****5.8 6DB BANDWIDTH MEASUREMENT****5.8.1 LIMITS OF 6DB BANDWIDTH MEASUREMENT**

The minimum of 6dB Bandwidth Measurement is 0.5 MHz.

**5.8.2 TEST INSTRUMENTS**

| Description & Manufacturer | Model No. | Serial No.   | Calibrated Until |
|----------------------------|-----------|--------------|------------------|
| R&S SPECTRUM ANALYZER      | FSP       | 1093.4495.30 | Dec. 19, 2003    |

**NOTE:**

- 1.The measurement uncertainty is less than +/- 2.6dB, which is calculated as per the NAMAS document NIS81.
- 2.The calibration interval of the above test instruments is 12 months and the calibrations are traceable to NML/ROC and NIST/USA.

### 5.8.3 TEST PROCEDURE

The transmitter output was connected to the spectrum analyzer through an attenuator. The bandwidth of the fundamental frequency was measured by spectrum analyzer with 100 kHz RBW and 100 kHz VBW. The 6 dB bandwidth is defined as the total spectrum the power of which is higher than peak power minus 6 dB.

### 5.8.4 DEVIATION FROM TEST STANDARD

No deviation

### 5.8.5 TEST SETUP



### 5.8.6 EUT OPERATING CONDITIONS

The software provided by client to enable the EUT under transmission condition continuously at lowest, middle and highest channel frequencies individually.



## 5.8.7 TEST RESULTS

|                             |  |                                 |                         |
|-----------------------------|--|---------------------------------|-------------------------|
| <b>EUT</b>                  | Wireless Dual Band Enterprise Access Point | <b>MODEL</b>                    | RBT3K-AG                |
| <b>INPUT POWER (SYSTEM)</b> | 120Vac, 60Hz                               | <b>ENVIRONMENTAL CONDITIONS</b> | 27deg.C, 57%RH, 974 hPa |
| <b>TEST MODE</b>            | Normal                                     | <b>TEST BY</b>                  | Hank Chung              |

| <b>CHANNEL</b> | <b>CHANNEL FREQUENCY (MHz)</b> | <b>6 dB BANDWIDTH (MHz)</b> | <b>MINIMUM LIMIT (MHz)</b> | <b>PASS/FAIL</b> |
|----------------|--------------------------------|-----------------------------|----------------------------|------------------|
| 9              | 5745                           | 16.56                       | 0.5                        | PASS             |
| 11             | 5785                           | 16.56                       | 0.5                        | PASS             |
| 13             | 5825                           | 16.56                       | 0.5                        | PASS             |



CH9

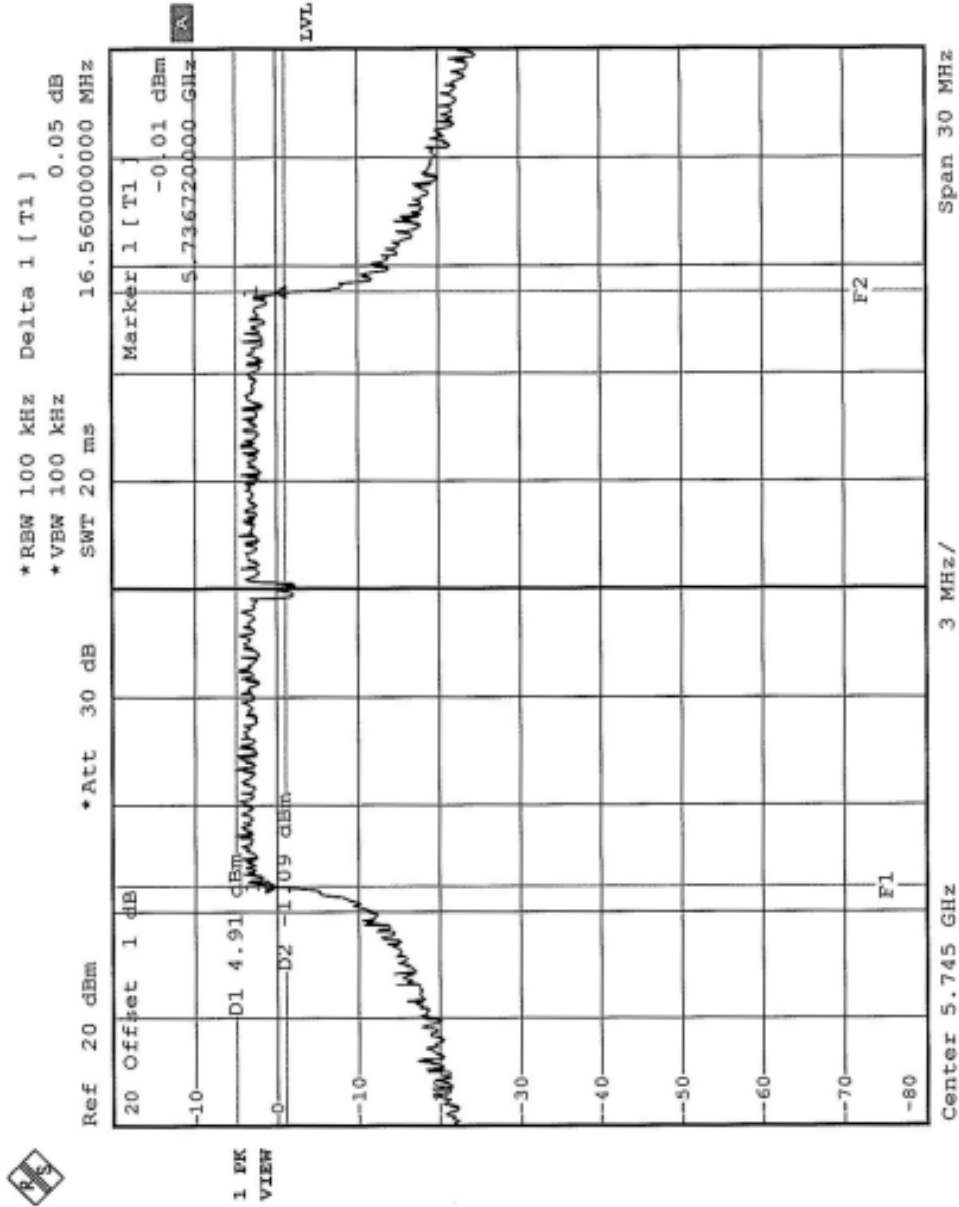



CH11

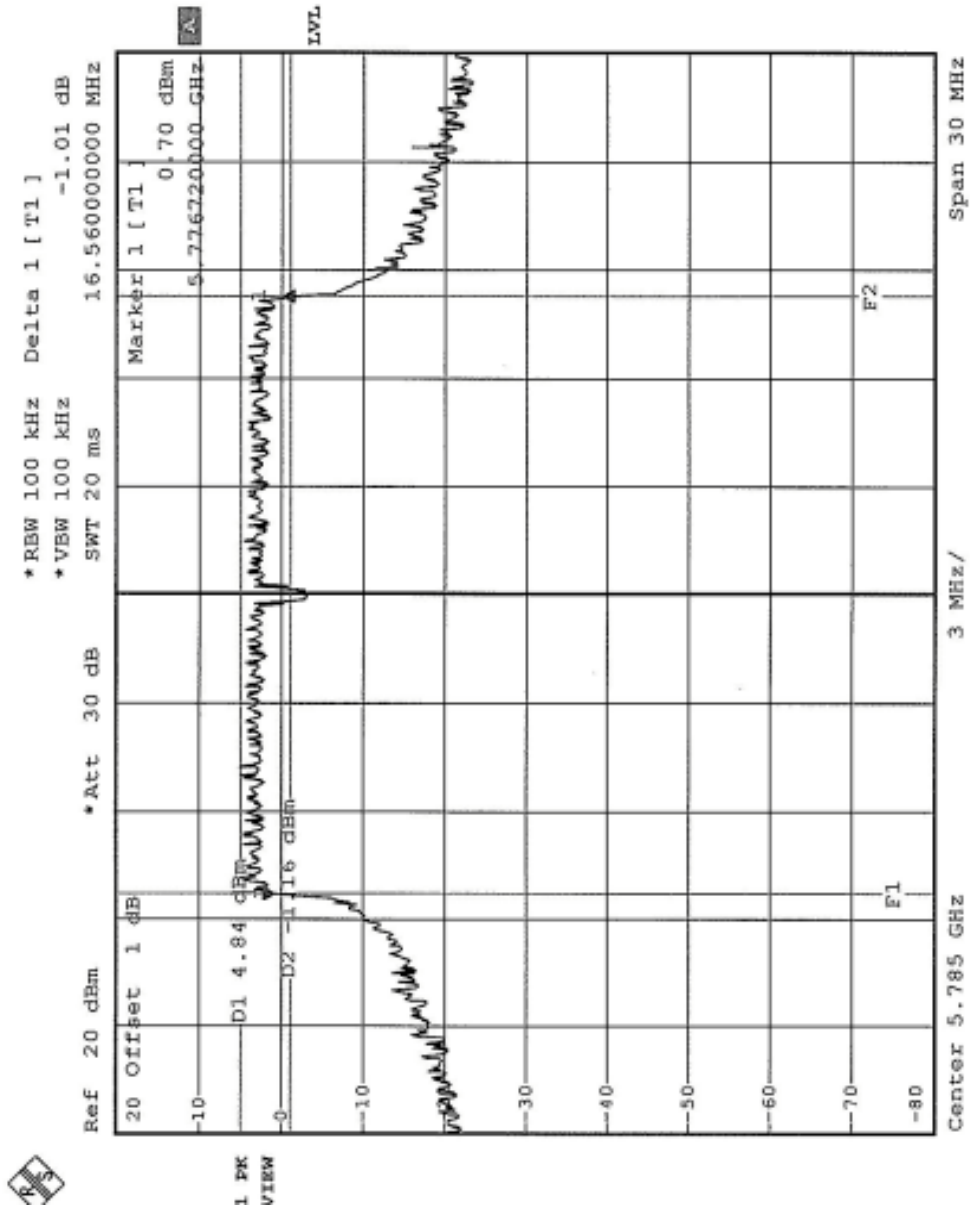



CH13

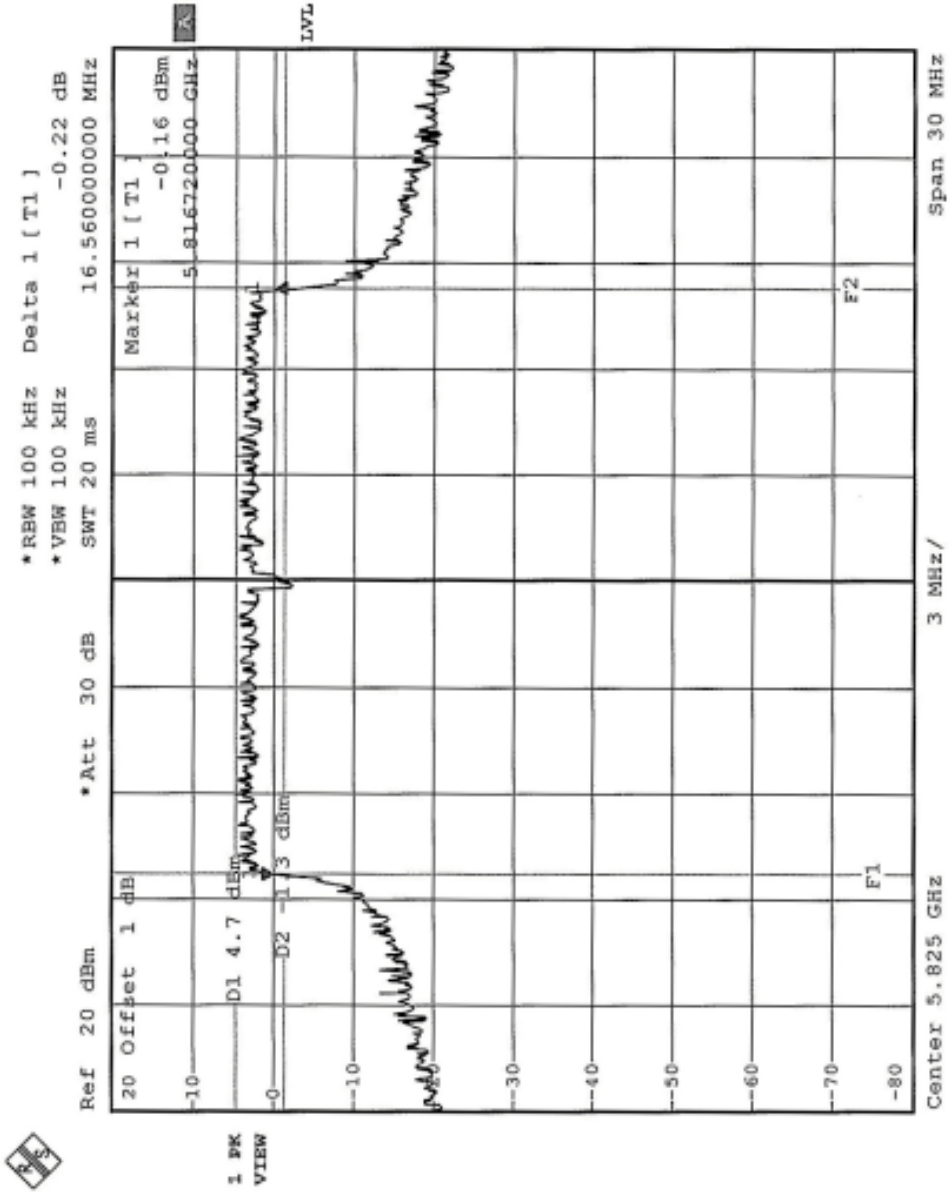



|                             |  |                                 |                         |
|-----------------------------|--|---------------------------------|-------------------------|
| <b>EUT</b>                  | Wireless Dual Band Enterprise Access Point | <b>MODEL</b>                    | RBT3K-AG                |
| <b>INPUT POWER (SYSTEM)</b> | 120Vac, 60Hz                               | <b>ENVIRONMENTAL CONDITIONS</b> | 27deg.C, 56%RH, 974 hPa |
| <b>TEST MODE</b>            | Turbo                                      | <b>TEST BY</b>                  | Hank Chung              |

| <b>CHANNEL</b> | <b>CHANNEL FREQUENCY (MHz)</b> | <b>6 dB BANDWIDTH (MHz)</b> | <b>MINIMUM LIMIT (MHz)</b> | <b>PASS/FAIL</b> |
|----------------|--------------------------------|-----------------------------|----------------------------|------------------|
| 4              | 5760                           | 33.12                       | 0.5                        | PASS             |
| 5              | 5800                           | 32.94                       | 0.5                        | PASS             |



CH4

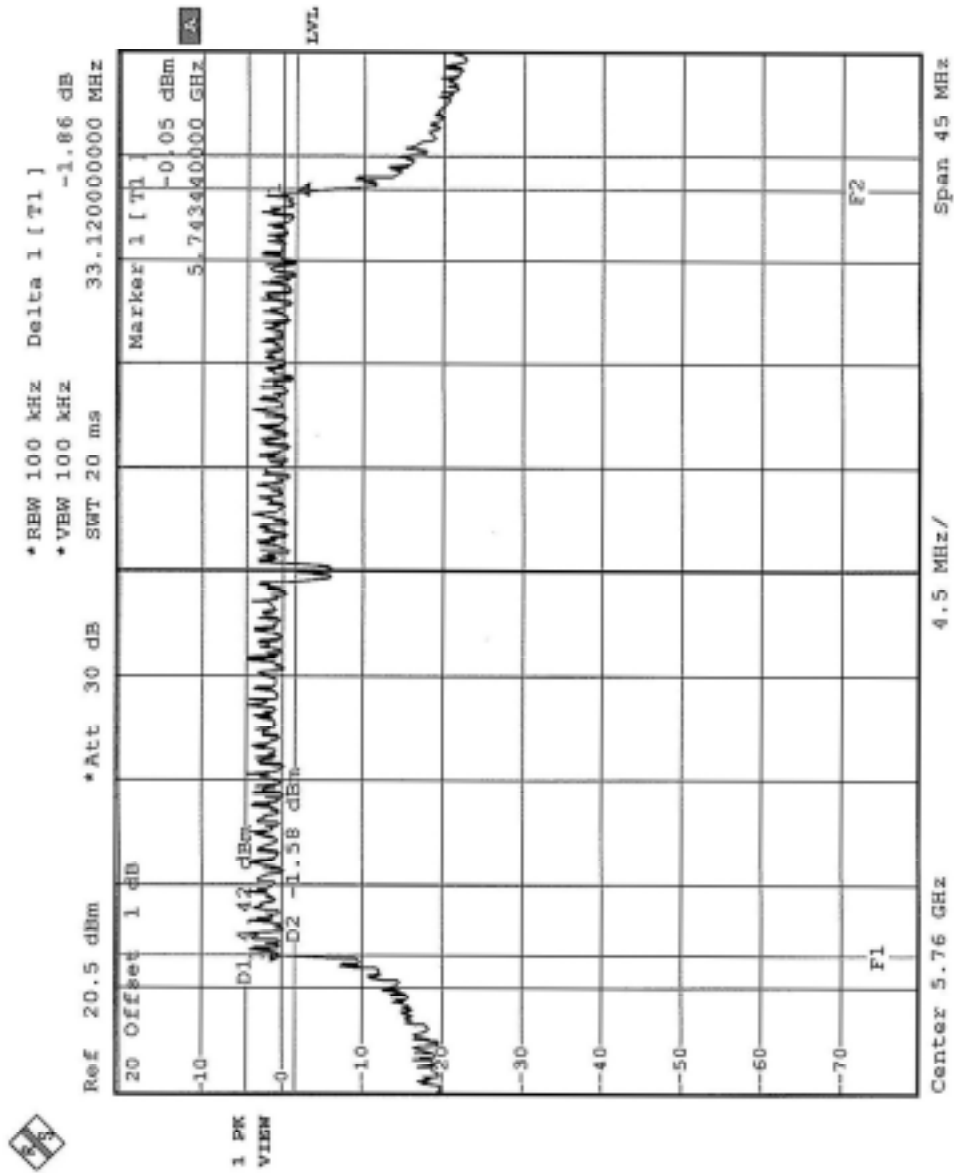





CH5

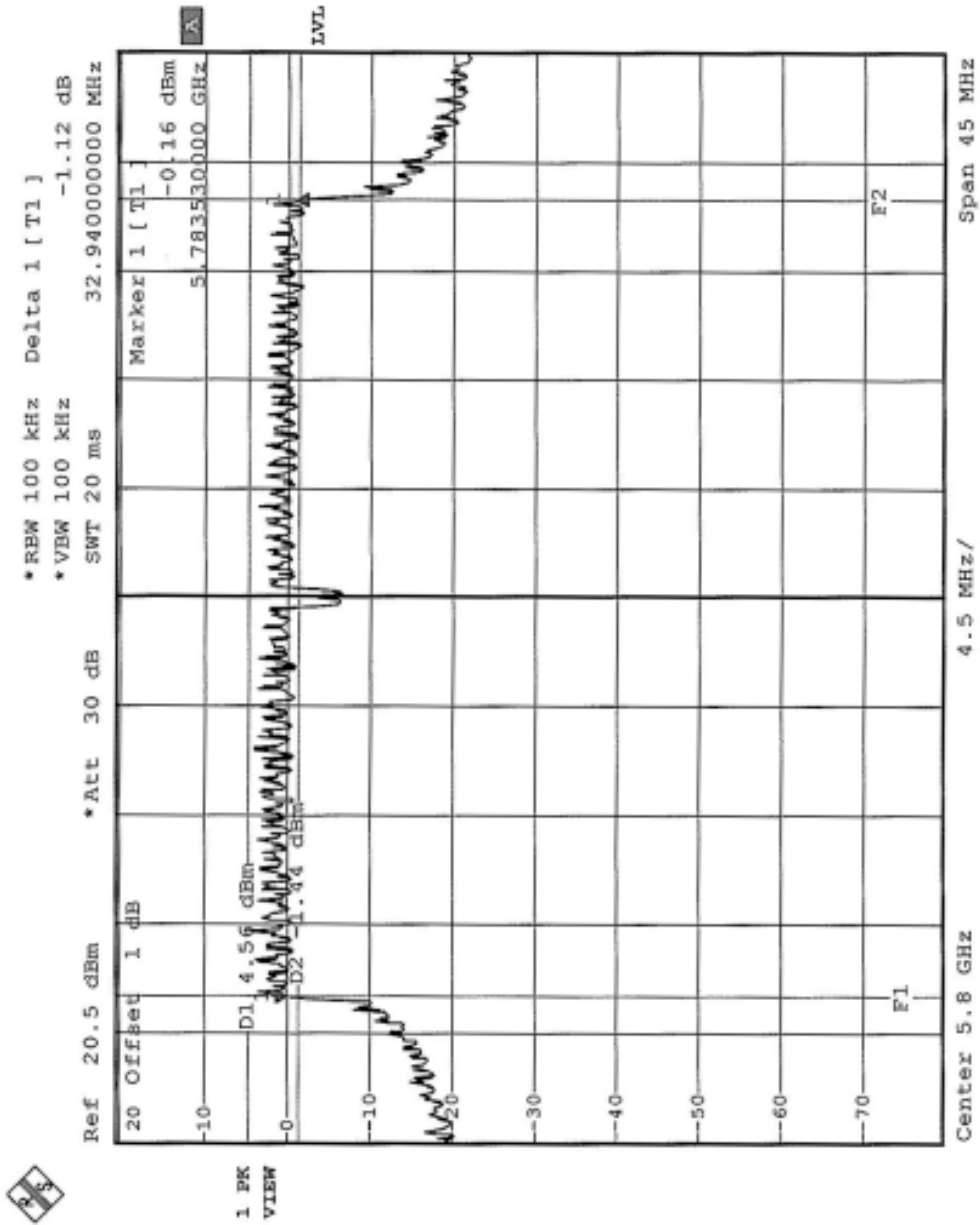



## 5.9 MAXIMUM PEAK OUTPUT POWER

### 5.9.1 LIMITS OF PEAK TRANSMIT POWER MEASUREMENT

The Maximum Peak Output Power Measurement is 30dBm.

### 5.9.2 INSTRUMENTS

| Description & Manufacturer | Model No. | Serial No. | Calibrated Until |
|----------------------------|-----------|------------|------------------|
| R&S SPECTRUM ANALYZER      | FSP30     | 100019     | Dec. 19, 2003    |
| R&S SIGNAL GENERATOR       | SMP04     | 100011     | May 28, 2004     |
| TEKTRONIX OSCILLOSCOPE     | TDS 220   | B048470    | Mar. 05, 2004    |
| NARDA DETECTOR             | 4503A     | FSCM99899  | NA               |

**NOTE:**

The calibration interval of the above test instruments is 12 months and the calibrations are traceable to NML/ROC and NIST/USA.



### 5.9.3 TEST PROCEDURES

1. A detector was used on the output port of the EUT. An oscilloscope was used to read the peak response of the detector.
2. Replaced the EUT by the signal generator. The center frequency of the S.G was adjusted to the center frequency of the measured channel.
3. Adjusted the power to have the same peak reading on oscilloscope. Record the power level.

### 5.9.4 TEST SETUP

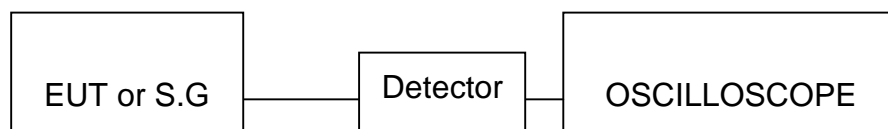

### 5.9.5 EUT OPERATING CONDITIONS

The software provided by client to enable the EUT under transmission condition continuously at specific channel frequencies individually.



5.9.6 TEST RESULTS

|                             |  |                                 |                         |
|-----------------------------|--|---------------------------------|-------------------------|
| <b>EUT</b>                  | Wireless Dual Band Enterprise Access Point | <b>MODEL</b>                    | RBT3K-AG                |
| <b>INPUT POWER (SYSTEM)</b> | 120Vac, 60Hz                               | <b>ENVIRONMENTAL CONDITIONS</b> | 24deg.C, 64%RH, 974 hPa |
| <b>TEST MODE</b>            | Normal                                     | <b>TEST BY</b>                  | Hank Chung              |

| <b>CHANNEL</b> | <b>CHANNEL FREQUENCY (MHz)</b> | <b>PEAK POWER OUTPUT (dBm)</b> | <b>PEAK POWER LIMIT (dBm)</b> | <b>PASS/FAIL</b> |
|----------------|--------------------------------|--------------------------------|-------------------------------|------------------|
| 9              | 5745                           | 20.08                          | 30                            | PASS             |
| 11             | 5785                           | 20.4                           | 30                            | PASS             |
| 13             | 5825                           | 21.0                           | 30                            | PASS             |

|                             |  |                                 |                         |
|-----------------------------|--|---------------------------------|-------------------------|
| <b>EUT</b>                  | Wireless Dual Band Enterprise Access Point | <b>MODEL</b>                    | RBT3K-AG                |
| <b>INPUT POWER (SYSTEM)</b> | 120Vac, 60Hz                               | <b>ENVIRONMENTAL CONDITIONS</b> | 24deg.C, 64%RH, 974 hPa |
| <b>TEST MODE</b>            | Turbo                                      | <b>TEST BY</b>                  | Hank Chung              |

| <b>CHANNEL</b> | <b>CHANNEL FREQUENCY (MHz)</b> | <b>PEAK POWER OUTPUT (dBm)</b> | <b>PEAK POWER LIMIT (dBm)</b> | <b>PASS/FAIL</b> |
|----------------|--------------------------------|--------------------------------|-------------------------------|------------------|
| 4              | 5760                           | 20.3                           | 30                            | PASS             |
| 5              | 5800                           | 20.1                           | 30                            | PASS             |



### 5.9.7 LIMITS OF POWER SPECTRAL DENSITY MEASUREMENT

The Maximum of Power Spectral Density Measurement is 8dBm.

### 5.9.8 TEST INSTRUMENTS

| Description & Manufacturer | Model No. | Serial No.   | Calibrated Until |
|----------------------------|-----------|--------------|------------------|
| R&S SPECTRUM ANALYZER      | FSP       | 1093.4495.30 | Dec. 19, 2003    |

**NOTE:**

- 1.The measurement uncertainty is less than +/- 2.6dB, which is calculated as per the NAMAS document NIS81.
- 2.The calibration interval of the above test instruments is 12 months and the calibrations are traceable to NML/ROC and NIST/USA.

### 5.9.9 TEST PROCEDURE

The transmitter output was connected to the spectrum analyzer through an attenuator, the bandwidth of the fundamental frequency was measured with the spectrum analyzer using 3 kHz RBW and 30 kHz VBW, set sweep time = span/3 kHz. The power spectral density was measured and recorded.

The sweep time is allowed to be longer than span/3 kHz for a full response of the mixer in the spectrum analyzer.

### 5.9.10 DEVIATION FROM TEST STANDARD

No deviation

### 5.9.11 TEST SETUP

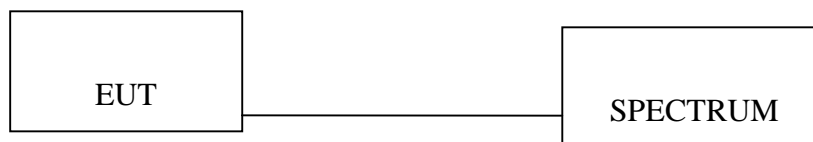

### 5.9.12 EUT OPERATING CONDITION

Same as Item 4.3.6



## 5.9.13 TEST RESULTS

|                             |  |                                 |                          |
|-----------------------------|--|---------------------------------|--------------------------|
| <b>EUT</b>                  | Wireless Dual Band Enterprise Access Point | <b>MODEL</b>                    | RBT3K-AG                 |
| <b>INPUT POWER (SYSTEM)</b> | 120Vac, 60Hz                               | <b>ENVIRONMENTAL CONDITIONS</b> | 57deg. C, 56%RH, 974 hPa |
| <b>TEST MODE</b>            | Normal                                     | <b>TEST BY</b>                  | Hank Chung               |

| <b>CHANNEL NUMBER</b> | <b>CHANNEL FREQUENCY (MHz )</b> | <b>RF POWER LEVEL IN 3 kHz BW (dBm)</b> | <b>MAXIMUM LIMIT (dBm)</b> | <b>PASS/FAIL</b> |
|-----------------------|---------------------------------|---|----------------------------|------------------|
| 9                     | 5745                            | -5.41                                   | 8                          | PASS             |
| 11                    | 5785                            | -6.28                                   | 8                          | PASS             |
| 13                    | 5825                            | -6.10                                   | 8                          | PASS             |



CH9

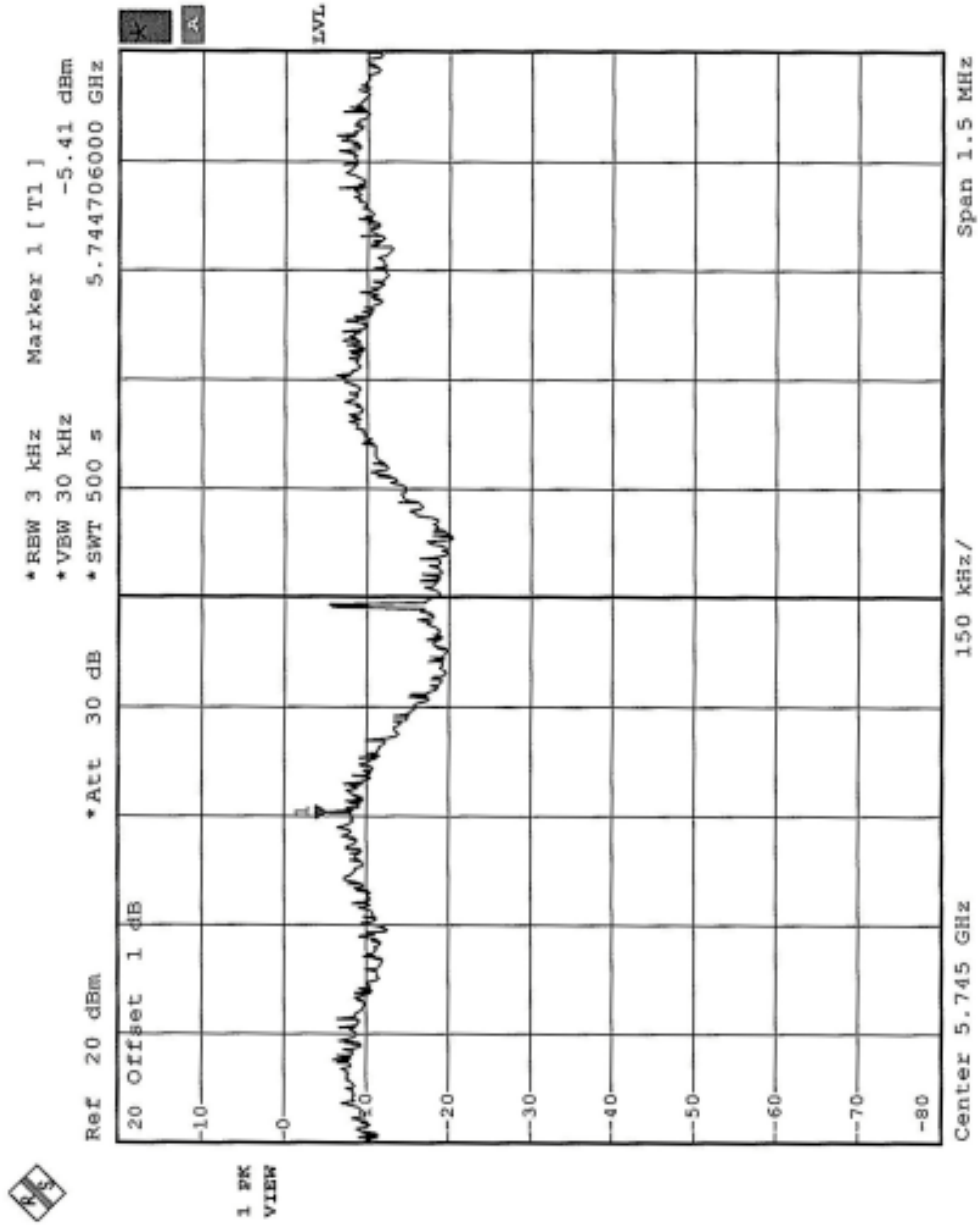





CH11

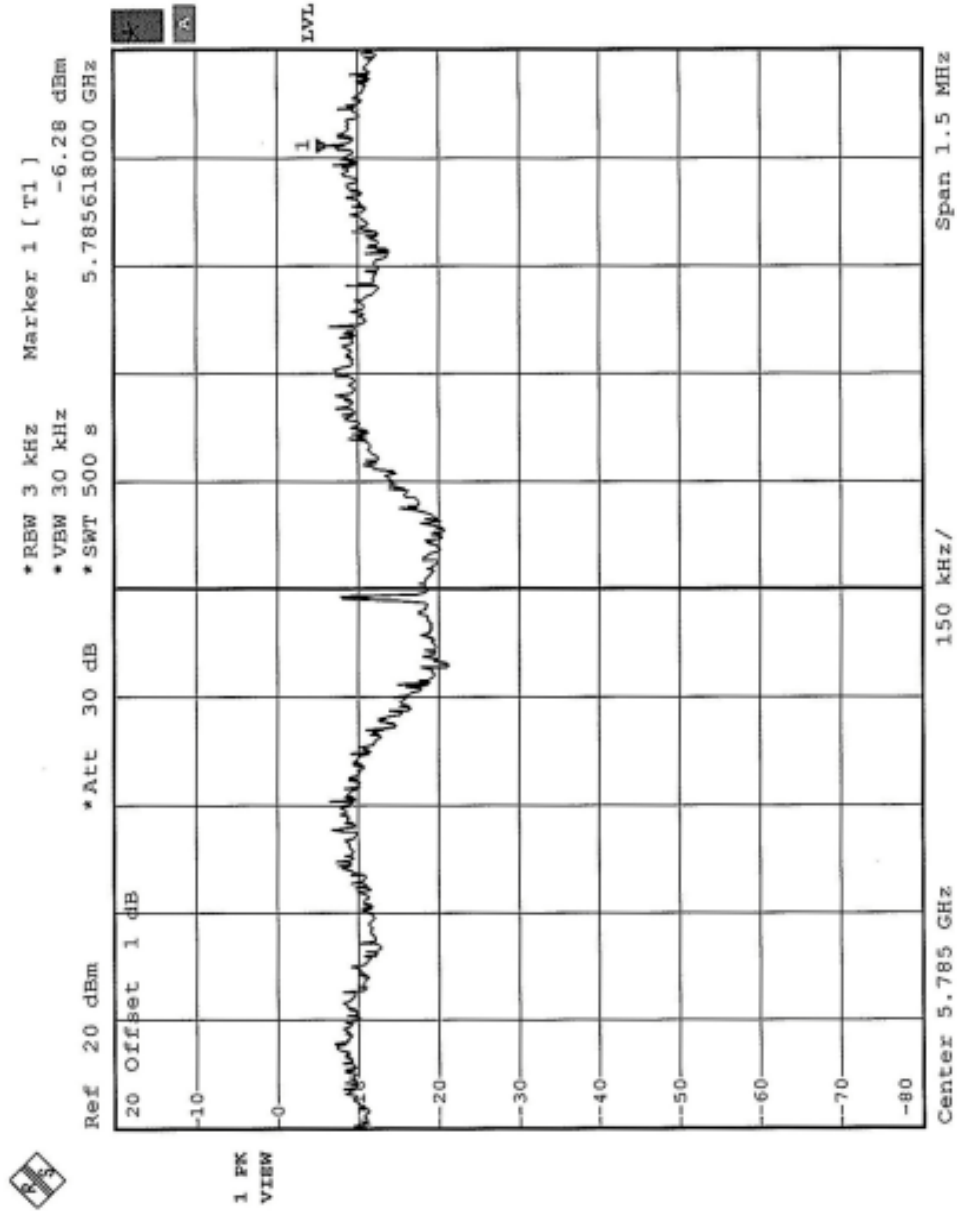



CH13

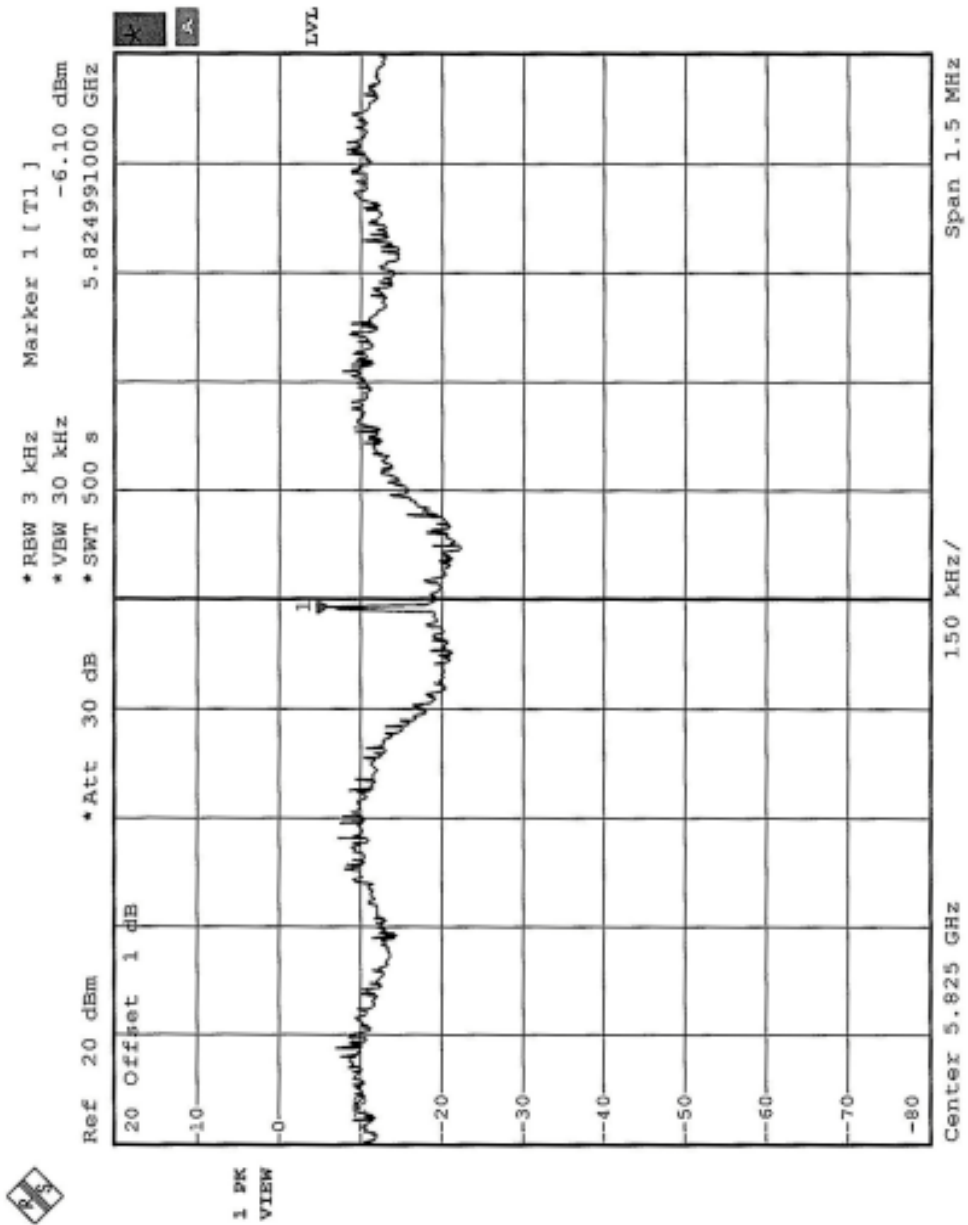



|                             |  |                                 |                          |
|-----------------------------|--|---------------------------------|--------------------------|
| <b>EUT</b>                  | Wireless Dual Band Enterprise Access Point | <b>MODEL</b>                    | RBT3K-AG                 |
| <b>INPUT POWER (SYSTEM)</b> | 120Vac, 60Hz                               | <b>ENVIRONMENTAL CONDITIONS</b> | 57deg. C, 56%RH, 974 hPa |
| <b>TEST MODE</b>            | Turbo                                      | <b>TEST BY</b>                  | Hank Chung               |

| <b>CHANNEL NUMBER</b> | <b>CHANNEL FREQUENCY (MHz )</b> | <b>RF POWER LEVEL IN 3 kHz BW (dBm)</b> | <b>MAXIMUM LIMIT (dBm)</b> | <b>PASS/FAIL</b> |
|-----------------------|---------------------------------|---|----------------------------|------------------|
| 4                     | 5760                            | -7.67                                   | 8                          | PASS             |
| 5                     | 5800                            | -11.71                                  | 8                          | PASS             |



CH4

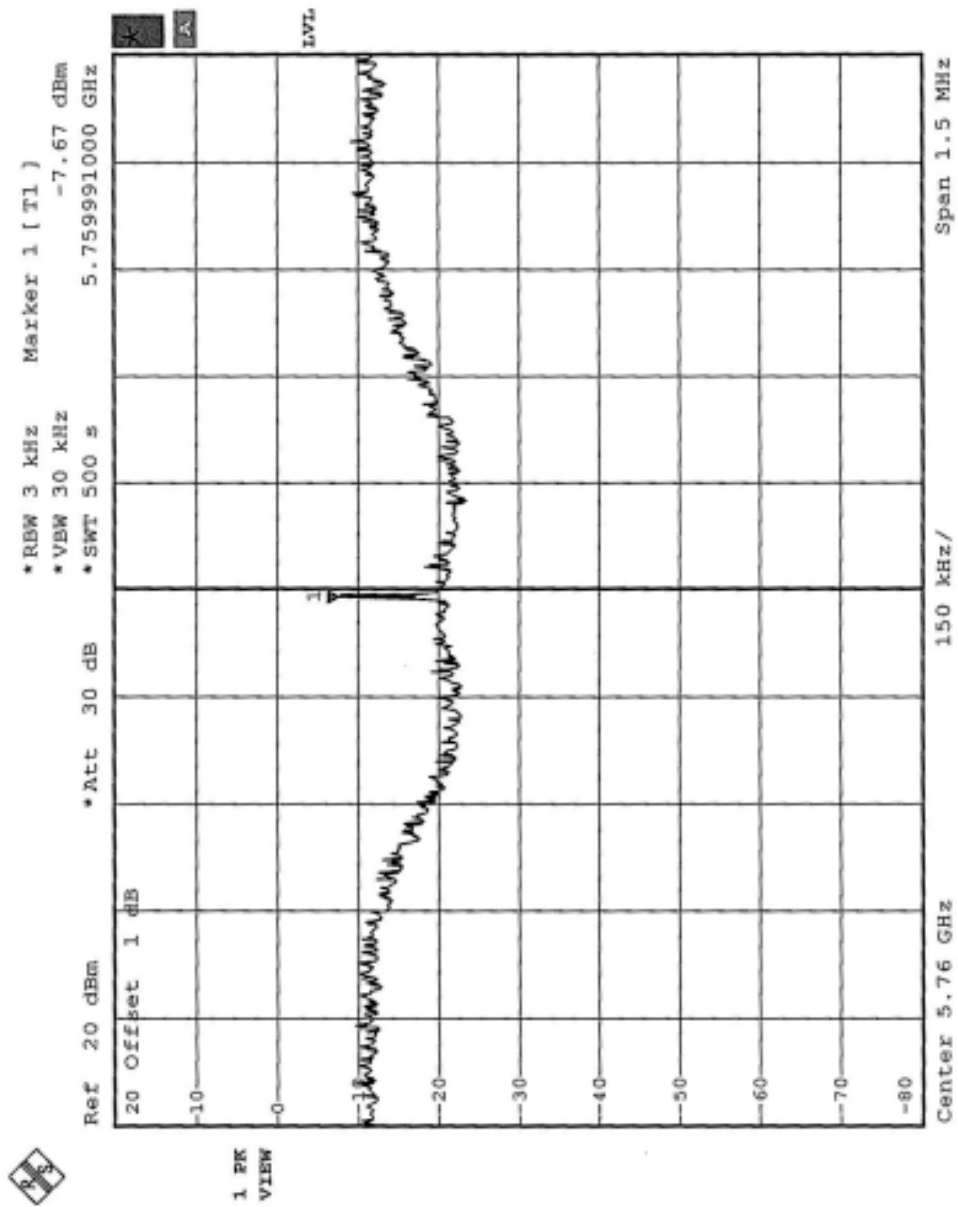



CH5

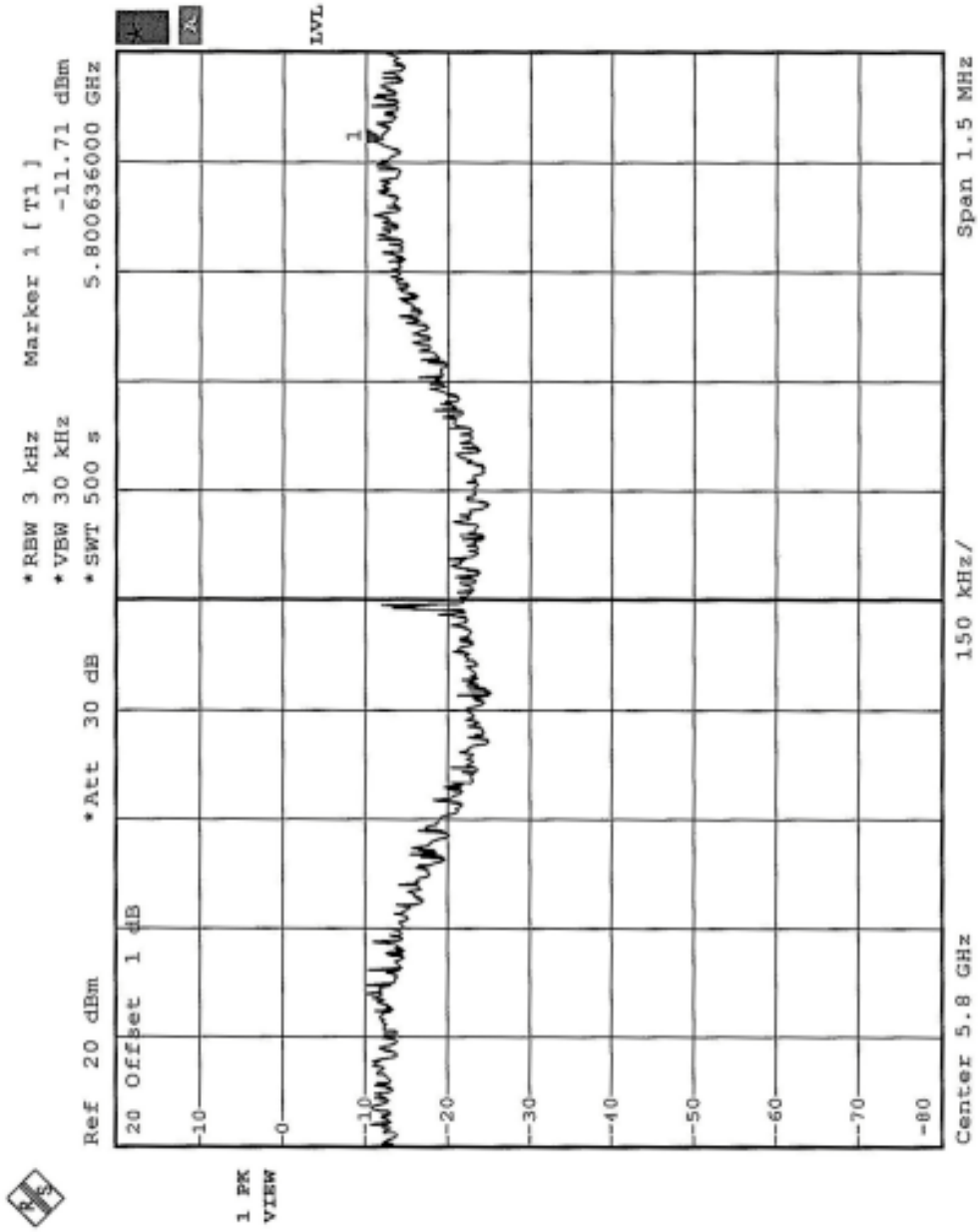



## 5.10 BAND EDGES MEASUREMENT

### 5.10.1 LIMITS OF BAND EDGES MEASUREMENT

Below  $-20\text{dB}$  of the highest emission level of operating band (in 100KHz Resolution Bandwidth).

### 5.10.2 TEST INSTRUMENTS

| Description & Manufacturer | Model No. | Serial No.   | Calibrated Until |
|----------------------------|-----------|--------------|------------------|
| R&S SPECTRUM ANALYZER      | FSP       | 1093.4495.30 | Dec. 19, 2003    |

**NOTE:**

- 1.The measurement uncertainty is less than  $\pm 2.6\text{dB}$ , which is calculated as per the NAMAS document NIS81.
- 2.The calibration interval of the above test instruments is 12 months and the calibrations are traceable to NML/ROC and NIST/USA.

### 5.10.3 TEST PROCEDURE

The transmitter output was connected to the spectrum analyzer via a low lose cable. Set both RBW and VBW of spectrum analyzer to 100 kHz with suitable frequency span including 100 kHz bandwidth from band edge. The band edges was measured and recorded.

### 5.10.4 DEVIATION FROM TEST STANDARD

No deviation



#### 5.10.5 EUT OPERATING CONDITION

Same as Item 4.3.6

#### 5.10.6 TEST RESULTS

The spectrum plots are attached on the following pages. D1 line indicates the highest level, D2 line indicates the 20dB offset below D1. It shows compliance with the requirement in part 15.247(C).



Normal Mode

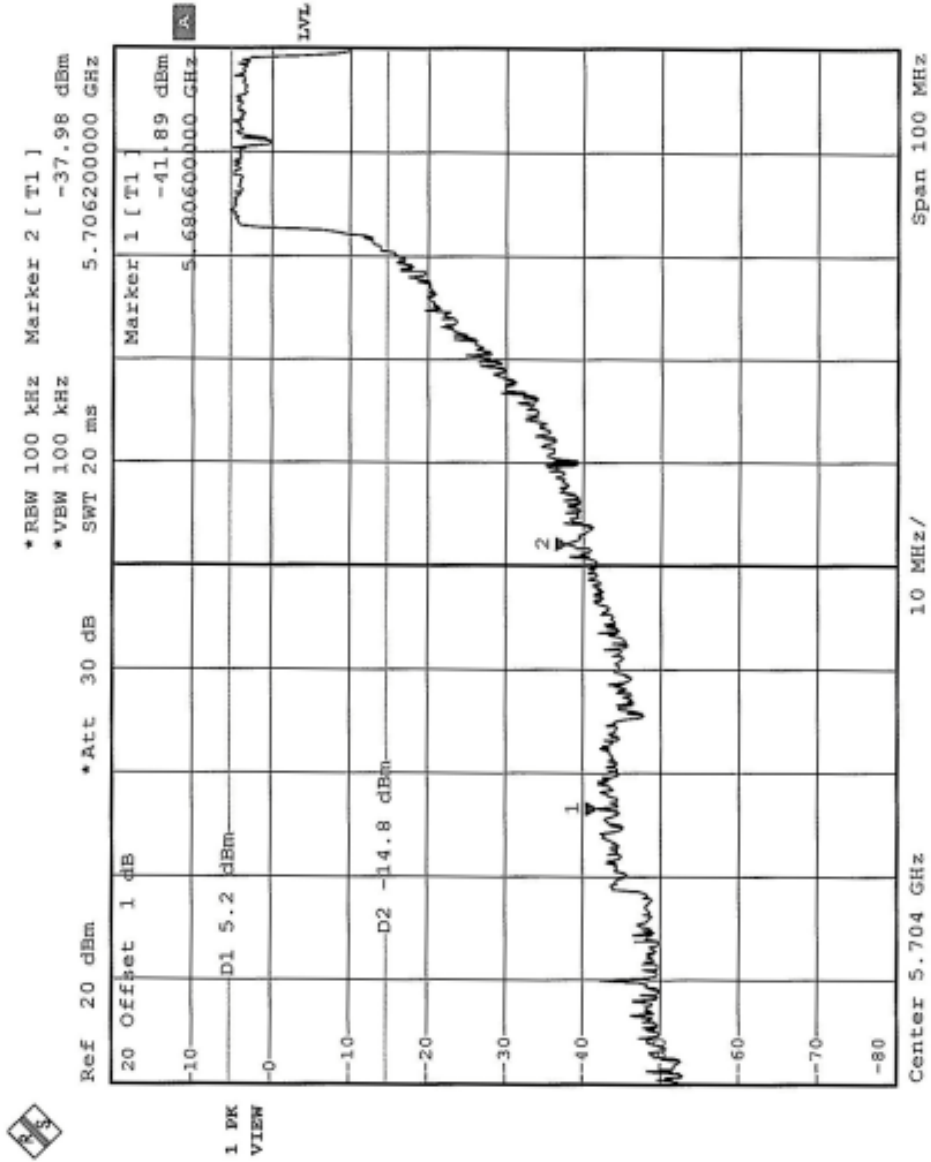



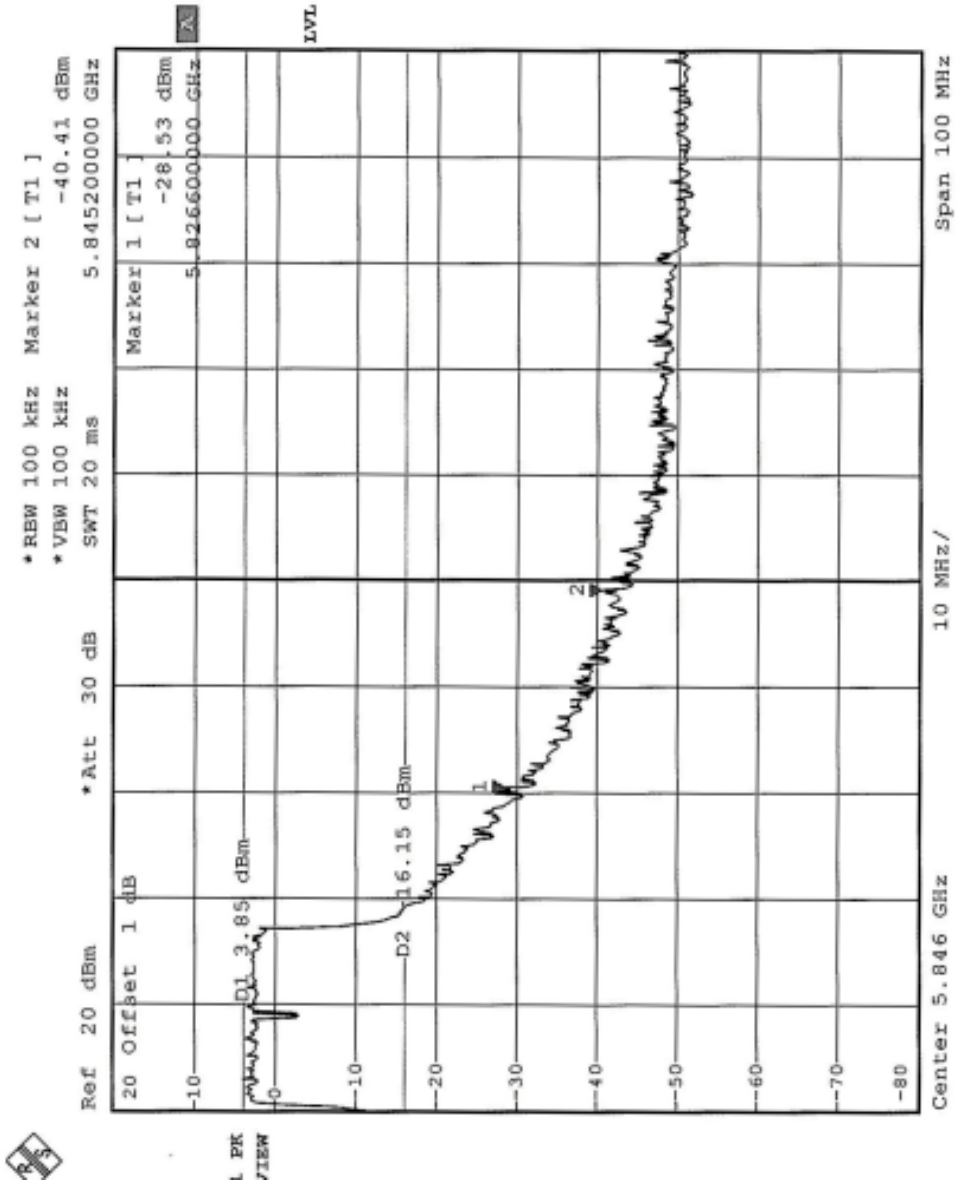



Turbo Mode

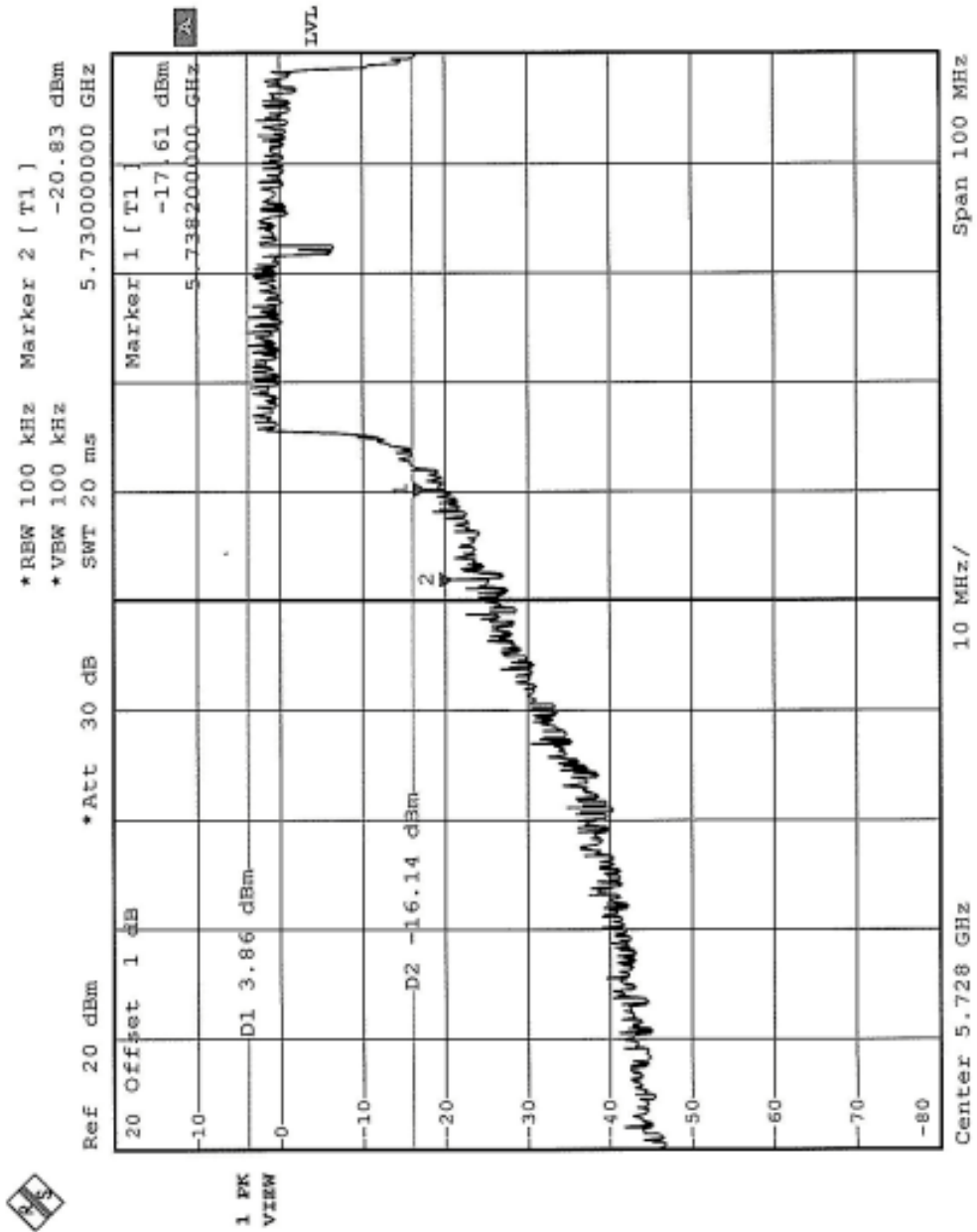

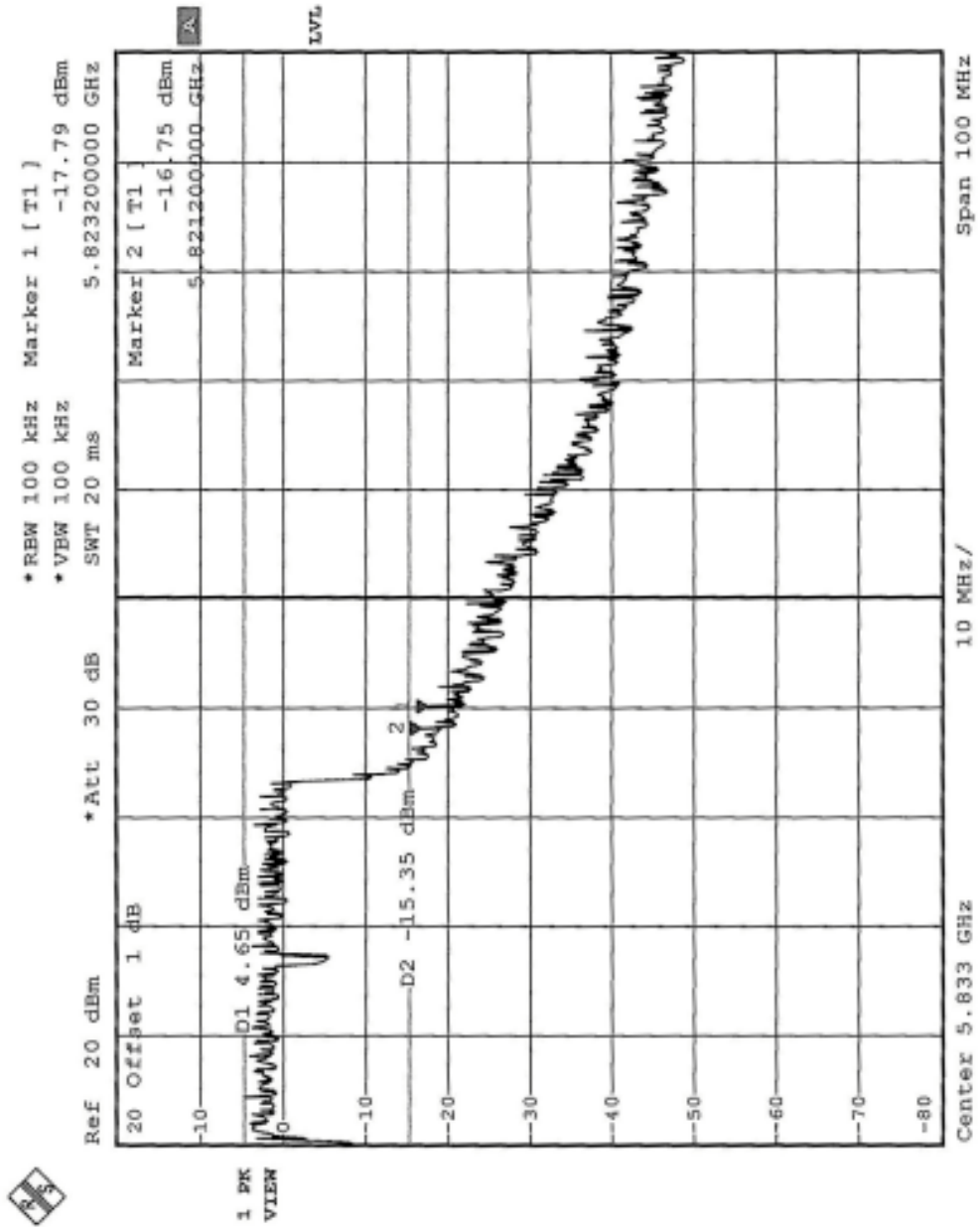



## **5.11 ANTENNA REQUIREMENT**

### **5.11.1 STANDARD APPLICABLE**

For intentional device, according to FCC 47 CFR Section 15.203, an intentional radiator shall be designed to ensure that no antenna other than that furnished by the responsible party shall be used with the device.

And according to FCC 47 CFR Section 15.407(a), if transmitting antennas of directional gain greater than 6dBi are used, the power shall be reduced by the amount in dB that the directional gain of the antenna exceeds 6dBi.

### **5.11.2 ANTENNA CONNECTED CONSTRUCTION**

The antenna used in this product is Dual-Band Omni-Directional Antenna with MMCX R/A Plug connector. The maximum Gain of the antenna is 4.5dBi.

## 6. PHOTOGRAPHS OF THE TEST CONFIGURATION CONDUCTED EMISSION TEST (With Adapter)

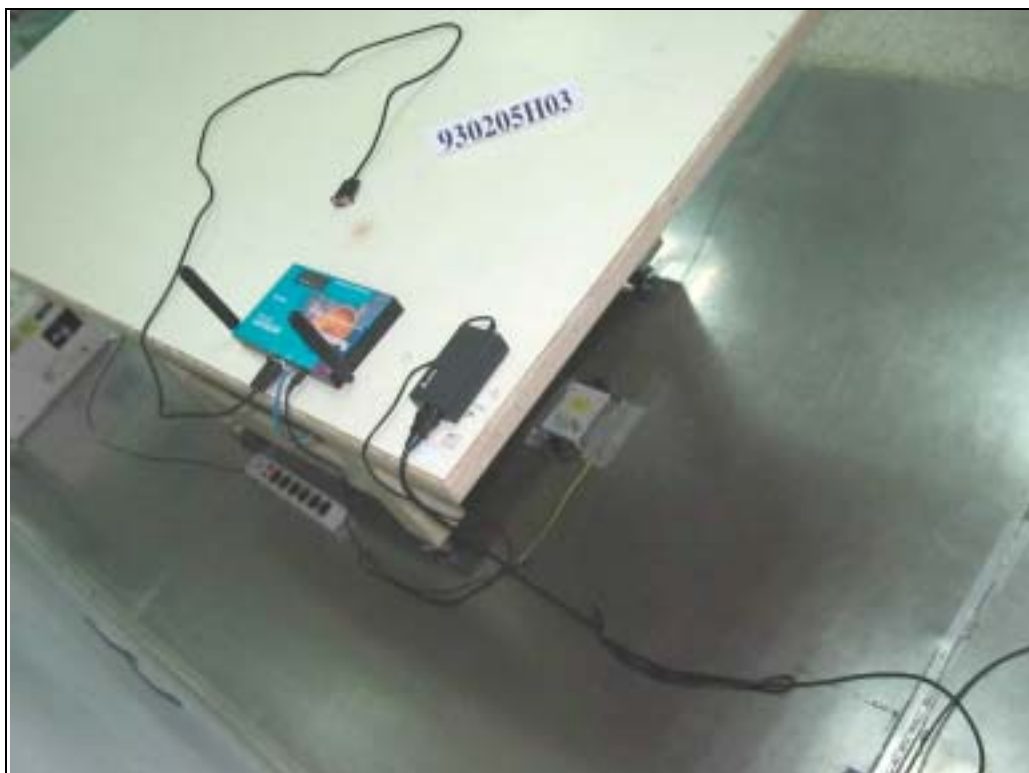

### CONDUCTED EMISSION TEST (With POE)



### RADIATED EMISSION TEST (With Adapter)

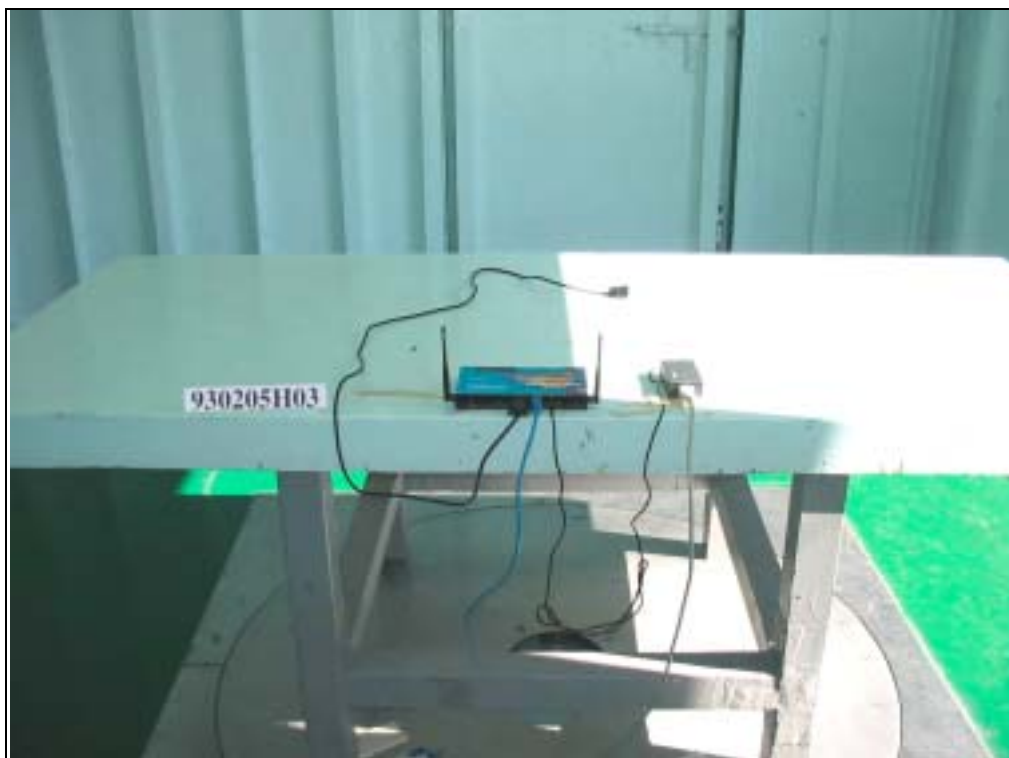



### RADIATED EMISSION TEST (With POE)







## 7. INFORMATION ON THE TESTING LABORATORIES

We, ADT Corp., were founded in 1988 to provide our best service in EMC and Safety consultation. Our laboratories are accredited and approved by the following approval agencies according to ISO/IEC 17025, Guide 25 or EN 45001:

|                    |                 |
|--------------------|-----------------|
| <b>USA</b>         | FCC, NVLAP, UL  |
| <b>Germany</b>     | TUV Rheinland   |
| <b>Japan</b>       | VCCI            |
| <b>New Zealand</b> | MoC             |
| <b>Norway</b>      | NEMKO           |
| <b>R.O.C.</b>      | BSMI, DGT, CNLA |

Copies of accreditation certificates of our laboratories obtained from approval agencies can be downloaded from our web site:

[www.adt.com.tw/index.5/phtml](http://www.adt.com.tw/index.5/phtml).

If you have any comments, please feel free to contact us at the following:

**Lin Kou EMC Lab:**

Tel: 886-2-26052180

Fax: 886-2-26052943

**Hsin Chu EMC Lab:**

Tel: 886-35-935343

Fax: 886-35-935342

**Lin Kou Safety Lab:**

Tel: 886-2-26093195

Fax: 886-2-26093184

**Lin Kou RF&Telecom Lab**

Tel: 886-3-3270910

Fax: 886-3-3270892

**Email:** [service@mail.adt.com.tw](mailto:service@mail.adt.com.tw)

**Web Site:** [www.adt.com.tw](http://www.adt.com.tw)

The address and road map of all our labs can be found in our web site also.