



RADIO TEST REPORT

FCC ID : HEDEAP104
Equipment : Indoor Wall-Plate WiFi 6 Access Point
Brand Name : **E d g e - c o r e**
Model Name : EAP104
Applicant : Accton Technology Corp
No. 1, Creation Rd. III, Science-based Industrial
Park Hsin Chu 30077, Taiwan R.O.C.
Manufacturer (1) : Accton Technology Corp
No. 1, Creation Rd. III, Science-based Industrial
Park Hsin Chu 30077, Taiwan R.O.C.
Manufacturer (2) : Accton Technology Corporation Zhunan Factory
1F.& 5F, No. 1 , Keyi St., Zhunan Township, Miaoli
County 350 - TAIWAN
Standard : 47 CFR FCC Part 15.247

The product was received on Sep. 26, 2022, and testing was started from Sep. 27, 2022 and completed on Oct. 29, 2022. We, Sporton International Inc. Hsinchu Laboratory, would like to declare that the tested sample has been evaluated in accordance with the procedures given in ANSI C63.10-2013 and shown compliance with the applicable technical standards.

The test results in this report apply exclusively to the tested model / sample. Without written approval of Sporton International Inc. Hsinchu Laboratory, the test report shall not be reproduced except in full.



Approved by: Sam Chen

Sporton International Inc. Hsinchu Laboratory
No.8, Ln. 724, Bo'ai St., Zhubei City, Hsinchu County 302010, Taiwan (R.O.C.)



Table of Contents

History of this test report.....3

Summary of Test Result.....4

1 General Description5

1.1 Information.....5

1.2 Applicable Standards8

1.3 Testing Location Information8

1.4 Measurement Uncertainty8

2 Test Configuration of EUT9

2.1 Test Channel Mode9

2.2 The Worst Case Measurement Configuration10

2.3 EUT Operation during Test11

2.4 Accessories11

2.5 Support Equipment.....12

2.6 Test Setup Diagram13

3 Transmitter Test Result16

3.1 AC Power-line Conducted Emissions16

3.2 DTS Bandwidth.....18

3.3 Maximum Conducted Output Power19

3.4 Power Spectral Density22

3.5 Emissions in Non-restricted Frequency Bands24

3.6 Emissions in Restricted Frequency Bands.....25

4 Test Equipment and Calibration Data29

Appendix A. Test Results of AC Power-line Conducted Emissions

Appendix B. Test Results of DTS Bandwidth

Appendix C. Test Results of Maximum Conducted Output Power

Appendix D. Test Results of Power Spectral Density

Appendix E. Test Results of Emissions in Non-restricted Frequency Bands

Appendix F. Test Results of Emissions in Restricted Frequency Bands

Appendix G. Test Photos

Photographs of EUT v01



Summary of Test Result

Report Clause	Ref Std. Clause	Test Items	Result (PASS/FAIL)	Remark
1.1.2	15.203	Antenna Requirement	PASS	-
3.1	15.207	AC Power-line Conducted Emissions	PASS	-
3.2	15.247(a)	DTS Bandwidth	PASS	-
3.3	15.247(b)	Maximum Conducted Output Power	PASS	-
3.4	15.247(e)	Power Spectral Density	PASS	-
3.5	15.247(d)	Emissions in Non-restricted Frequency Bands	PASS	-
3.6	15.247(d)	Emissions in Restricted Frequency Bands	PASS	-

Declaration of Conformity:

1. The test results with all measurement uncertainty excluded are presented in accordance with the regulation limits or requirements declared by manufacturers. It's means measurement values may risk exceeding the limit of regulation standards, if measurement uncertainty is include in test results.
2. The measurement uncertainty please refer to report "Measurement Uncertainty".

Comments and Explanations:

The declared of product specification for EUT presented in the report are provided by the manufacturer, and the manufacturer takes all the responsibilities for the accuracy of product specification.

Reviewed by: Sam Chen**Report Producer: Sophia Shiung**



1 General Description

1.1 Information

1.1.1 RF General Information

Frequency Range (MHz)	IEEE Std. 802.11	Ch. Frequency (MHz)	Channel Number
2400-2483.5	b, g, n (HT20), VHT20, ax (HEW20)	2412-2462	1-11 [11]
2400-2483.5	n (HT40), VHT40, ax (HEW40)	2422-2452	3-9 [7]

Band	Mode	BWch (MHz)	Nant
2.4-2.4835GHz	802.11b	20	2TX
2.4-2.4835GHz	802.11g	20	2TX
2.4-2.4835GHz	802.11n HT20	20	2TX
2.4-2.4835GHz	802.11n HT20-BF	20	2TX
2.4-2.4835GHz	VHT20	20	2TX
2.4-2.4835GHz	VHT20-BF	20	2TX
2.4-2.4835GHz	802.11ax HEW20	20	2TX
2.4-2.4835GHz	802.11ax HEW20-BF	20	2TX
2.4-2.4835GHz	802.11n HT40	40	2TX
2.4-2.4835GHz	802.11n HT40-BF	40	2TX
2.4-2.4835GHz	VHT40	40	2TX
2.4-2.4835GHz	VHT40-BF	40	2TX
2.4-2.4835GHz	802.11ax HEW40	40	2TX
2.4-2.4835GHz	802.11ax HEW40-BF	40	2TX

Note:

- ◆ 11b mode uses a combination of DSSS-DBPSK, DQPSK, CCK modulation.
- ◆ 11g, HT20 and HT40 use a combination of OFDM-BPSK, QPSK, 16QAM, 64QAM modulation.
- ◆ VHT20, VHT40 use a combination of OFDM-BPSK, QPSK, 16QAM, 64QAM, 256QAM modulation.
- ◆ HEW20, HEW40 use a combination of OFDMA-BPSK, QPSK, 16QAM, 64QAM, 256QAM modulation.
- ◆ BWch is the nominal channel bandwidth.



1.1.2 Antenna Information

Ant.	Port			Brand	Model Name	Antenna Type	Connector	Gain (dBi)
	WLAN 2.4GHz	WLAN 5GHz	Bluetooth					
1	1	-	-	Accton	EC-3-PB01-001	Dipole	I-PEX	3.94
2	2	-	-	Accton	EC-3-PB01-002	PIFA	I-PEX	3.11
3	-	1	-	Accton	EC-5-PB02-001	Monopole	I-PEX	5.21
4	-	2	-	Accton	EC-5-PB02-002	Monopole	I-PEX	5.11
5	-	-	1	Accton	EC-4-PB10-001	Dipole	I-PEX	4.22

Note 1: The above information was declared by manufacturer.

Note 2: Directional gain information

Type	Maximum Output Power	Power Spectral Density
Non-BF	Directional gain = Max.gain + array gain. For power measurements on IEEE 802.11 devices Array Gain = 0 dB (i.e., no array gain) for N ANT ≤ 4	$Directional\ iGain = 10 \cdot \log \left[\frac{\sum_{j=1}^{N_{SS}} \left\{ \sum_{k=1}^{N_{ANT}} g_{j,k} \right\}^2}{N_{ANT}} \right]$
BF	$Directional\ iGain = 10 \cdot \log \left[\frac{\sum_{j=1}^{N_{SS}} \left\{ \sum_{k=1}^{N_{ANT}} g_{j,k} \right\}^2}{N_{ANT}} \right]$	$Directional\ iGain = 10 \cdot \log \left[\frac{\sum_{j=1}^{N_{SS}} \left\{ \sum_{k=1}^{N_{ANT}} g_{j,k} \right\}^2}{N_{ANT}} \right]$

Ex.

Directional Gain (NSS1) formula :

$$Directional\ iGain = 10 \cdot \log \left[\frac{\sum_{j=1}^{N_{SS}} \left\{ \sum_{k=1}^{N_{ANT}} g_{j,k} \right\}^2}{N_{ANT}} \right]$$

$NSS1(g1,1) = 10^{G1/20}$; $NSS1(g1,2) = 10^{G2/20}$;

$g_{j,k} = (Nss1(g1,1) + Nss1(g1,2))^2$

$DG = 10 \log[(Nss1(g1,1) + Nss1(g1,2))^2 / N_{ANT}] \Rightarrow 10 \log[(10^{G1/20} + 10^{G2/20})^2 / N_{ANT}]$

Where ;

$G1 = 10$; $G2 = 10$

2.4G = 3.94 dBi; G2 = 3.11dBi; DG = 6.55 dBi

5G G1 = 5.21 dBi; G2 = 5.11 dBi; DG = 8.16 dBi



Note 3: For WLAN 2.4GHz function:

For IEEE 802.11 b/g/n/VHT/ax (2TX/2RX):

Port 1 and Port 2 can be used as transmitting/receiving antenna.

Port 1 and Port 2 could transmit/receive simultaneously.

For WLAN 5GHz function:

For IEEE 802.11a/n/ac/ax (2TX/2RX):

Port 1 and Port 2 can be used as transmitting/receiving antenna.

Port 1 and Port 2 could transmit/receive simultaneously.

For Bluetooth function (1TX/1RX):

Port 1 can be used as transmitting/receiving antenna.

1.1.3 Mode Test Duty Cycle

Mode	DC	DCF(dB)	T(s)	VBW(Hz) ≥ 1/T
802.11b	0.982	0.08	n/a (DC≥0.98)	n/a (DC≥0.98)
802.11g	0.992	0.03	n/a (DC≥0.98)	n/a (DC≥0.98)
802.11ax HEW20	0.997	0.01	n/a (DC≥0.98)	n/a (DC≥0.98)
802.11ax HEW40	0.998	0.01	n/a (DC≥0.98)	n/a (DC≥0.98)

Note:

- ◆ DC is Duty Cycle.
- ◆ DCF is Duty Cycle Factor.

1.1.4 EUT Operational Condition

EUT Power Type	From Power Adapter or PoE			
Beamforming Function	<input checked="" type="checkbox"/>	With beamforming	<input type="checkbox"/>	Without beamforming
	The product has beamforming function for n/VHT/ax in 2.4GHz and n/ac/ax in 5GHz.			
Function	<input checked="" type="checkbox"/>	Point-to-multipoint	<input type="checkbox"/>	Point-to-point
Support RU	<input checked="" type="checkbox"/>	Full RU	<input type="checkbox"/>	Partial RU
Test Software Version	QSPR V5.0-00197			

Note: The above information was declared by manufacturer.



1.2 Applicable Standards

According to the specifications of the manufacturer, the EUT must comply with the requirements of the following standards:

- ♦ 47 CFR FCC Part 15.247
- ♦ ANSI C63.10-2013

The following reference test guidance is not within the scope of accreditation of TAF.

- ♦ FCC KDB 558074 D01 v05r02
- ♦ FCC KDB 662911 D01 v02r01
- ♦ FCC KDB 414788 D01 v01r01

1.3 Testing Location Information

Testing Location Information	
Test Lab. : Sporton International Inc. Hsinchu Laboratory	
Hsinchu	ADD: No.8, Ln. 724, Bo'ai St., Zhubei City, Hsinchu County 302010, Taiwan (R.O.C.)
(TAF: 3787)	TEL: 886-3-656-9065 FAX: 886-3-656-9085
Test site Designation No. TW3787 with FCC.	
Conformity Assessment Body Identifier (CABID) TW3787 with ISED.	

Test Condition	Test Site No.	Test Engineer	Test Environment (°C / %)	Test Date
RF Conducted	TH03-CB	Owen Hsu	23.6~23.7 / 56~67	Oct. 01, 2022~ Oct. 29, 2022
Radiated < 1GHz	03CH06-CB	Stim Sung	23.5-24.5 / 45-55	Oct. 20, 2022~ Oct. 21, 2022
Radiated > 1GHz	03CH03-CB	Chris Lee	23.4~24.4 / 55~60	Sep. 27, 2022~ Oct. 28, 2022
AC Conduction	CO01-CB	Elvin Yeh	21~23 / 58-61	Oct. 24, 2022

1.4 Measurement Uncertainty

ISO/IEC 17025 requires that an estimate of the measurement uncertainties associated with the emissions test results be included in the report. The measurement uncertainties given below are based on a 95% confidence level (based on a coverage factor (k=2))

Test Items	Uncertainty	Remark
Conducted Emission (150kHz ~ 30MHz)	3.4 dB	Confidence levels of 95%
Radiated Emission (9kHz ~ 30MHz)	3.4 dB	Confidence levels of 95%
Radiated Emission (30MHz ~ 1,000MHz)	5.6 dB	Confidence levels of 95%
Radiated Emission (1GHz ~ 18GHz)	5.2 dB	Confidence levels of 95%
Radiated Emission (18GHz ~ 40GHz)	4.7 dB	Confidence levels of 95%
Conducted Emission	3.2 dB	Confidence levels of 95%
Output Power Measurement	0.8 dB	Confidence levels of 95%
Power Density Measurement	3.2 dB	Confidence levels of 95%
Bandwidth Measurement	2.0 %	Confidence levels of 95%



2 Test Configuration of EUT

2.1 Test Channel Mode

Mode	Power Setting
802.11b_Nss1,(1Mbps)_2TX	-
2412MHz	22.5
2437MHz	23
2457MHz	19
2462MHz	19
802.11g_Nss1,(6Mbps)_2TX	-
2412MHz	20
2437MHz	22
2457MHz	18
2462MHz	18
802.11ax HEW20_Nss1,(MCS0)_2TX	-
2412MHz	19.5
2437MHz	21
2457MHz	18.5
2462MHz	18
802.11ax HEW40_Nss1,(MCS0)_2TX	-
2422MHz	17
2437MHz	17.5
2452MHz	17
802.11ax HEW20-BF_Nss1,(MCS0)_2TX	-
2412MHz	19.5
2437MHz	21
2457MHz	18.5
2462MHz	18
802.11ax HEW40-BF_Nss1,(MCS0)_2TX	-
2422MHz	17
2437MHz	17.5
2452MHz	17

Note:

- ♦ Evaluated HEW20 / HEW40 mode only, due to similar modulation. The power setting of HT20 / HT40 / VHT20 / VHT40 modes are the same or lower than HEW20 / HEW40.
- ♦ The EUT supports non-beamforming and beamforming modes, after evaluating, the non-beamforming mode has been selected to execute all tests. The beamforming mode evaluates the output power only.



2.2 The Worst Case Measurement Configuration

The Worst Case Mode for Following Conformance Tests	
Tests Item	AC power-line conducted emissions
Condition	AC power-line conducted measurement for line and neutral Test Voltage: 120Vac / 60Hz
Operating Mode	Normal Link
1	EUT + Adapter
2	EUT + PoE
Mode 2 generated the worst test result, so it was recorded in this report.	

The Worst Case Mode for Following Conformance Tests	
Tests Item	DTS Bandwidth Maximum Conducted Output Power Power Spectral Density Emissions in Non-restricted Frequency Bands
Test Condition	Conducted measurement at transmit chains

The Worst Case Mode for Following Conformance Tests	
Tests Item	Emissions in Restricted Frequency Bands
Test Condition	Radiated measurement If EUT consist of multiple antenna assembly (multiple antenna are used in EUT regardless of spatial multiplexing MIMO configuration), the radiated test should be performed with highest antenna gain of each antenna type.
Operating Mode < 1GHz	Normal Link
1	Normal link: EUT in X axis + Adapter
2	Normal link: EUT in Y axis + Adapter
3	Normal link: EUT in Z axis + Adapter
Mode 1 has been evaluated to be the worst case among Mode 1~3, thus measurement for Mode 4 will follow this same test mode.	
4	Normal link: EUT in Z axis + PoE
Mode 3 generated the worst test result, so it was recorded in this report.	
Operating Mode > 1GHz	CTX
After evaluating, the worst case was found as below. So the measurement will follow this same test configuration.	
1	EUT in Y axis for bandedge and EUT in X axis for harmonic



The Worst Case Mode for Following Conformance Tests	
Tests Item	Simultaneous Transmission Analysis - Co-location RF Exposure Evaluation
Operating Mode	
1	WLAN 2.4GHz + WLAN 5GHz + Bluetooth
Refer to Sporton Test Report No.: FA292606 for Co-location RF Exposure Evaluation.	

Note: The adapter and PoE were for measurement only and would not be marketed. Their information is showed as below:

Equipment	Brand	Model
Adapter	ITE	MU12AR120100-A1
PoE	PHIHONG	POEA30U-1ATE

2.3 EUT Operation during Test

For CTX Mode:

The EUT was programmed to be in continuously transmitting mode.

For Normal Link Mode:

During the test, the EUT operation to normal function.

2.4 Accessories

Others
Wall-mounted rack*1
RJ-45 cable*1 (Non-shielded, 0.05m)



2.5 Support Equipment

For AC Conduction:

Support Equipment				
No.	Equipment	Brand Name	Model Name	FCC ID
A	Pass-Thru NB	DELL	E6430	N/A
B	LAN1 NB	DELL	E6430	N/A
C	Device NB	DELL	E6430	N/A
D	Device	Accton	EAP104	N/A
E	2.4G NB	DELL	E6430	N/A
F	5G NB	DELL	E6430	N/A
G	iPad	Apple	A1430	N/A
H	PoE	PHIHONG	POEA30U-1ATE	N/A
I	LAN4 NB	DELL	E6430	N/A

For Radiated (below 1GHz):

Support Equipment				
No.	Equipment	Brand Name	Model Name	FCC ID
A	LAN1 NB	DELL	E4300	N/A
B	Pass-Thru NB	DELL	E4300	N/A
C	iPad	Apple	A1430	N/A
D	2.4G NB	DELL	E4300	N/A
E	5G NB	DELL	E4300	N/A
F	Adapter	ITE	MU12AR120100-A1	N/A

For Radiated (above 1GHz):

Support Equipment				
No.	Equipment	Brand Name	Model Name	FCC ID
A	NB	Lenovo	L440	N/A
B	Adapter	ITE	MU12AR120100-A1	N/A

For RF Conducted:

Support Equipment				
No.	Equipment	Brand Name	Model Name	FCC ID
A	NB	DELL	E4300	N/A
B	AC Adapter	ITE	MU12AR120100-A1	N/A

2.6 Test Setup Diagram

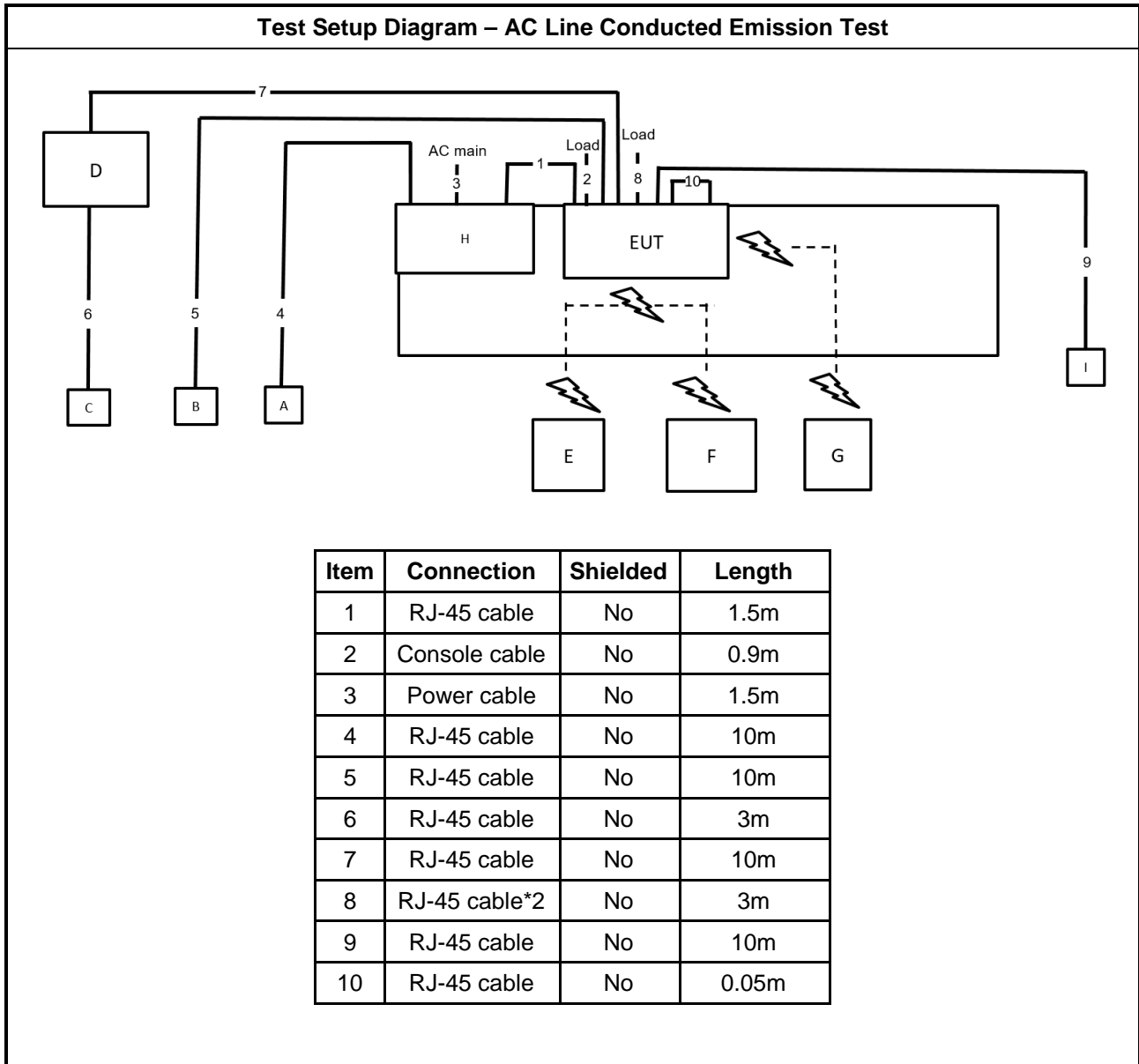

Test Setup Diagram - Radiated Test < 1GHz

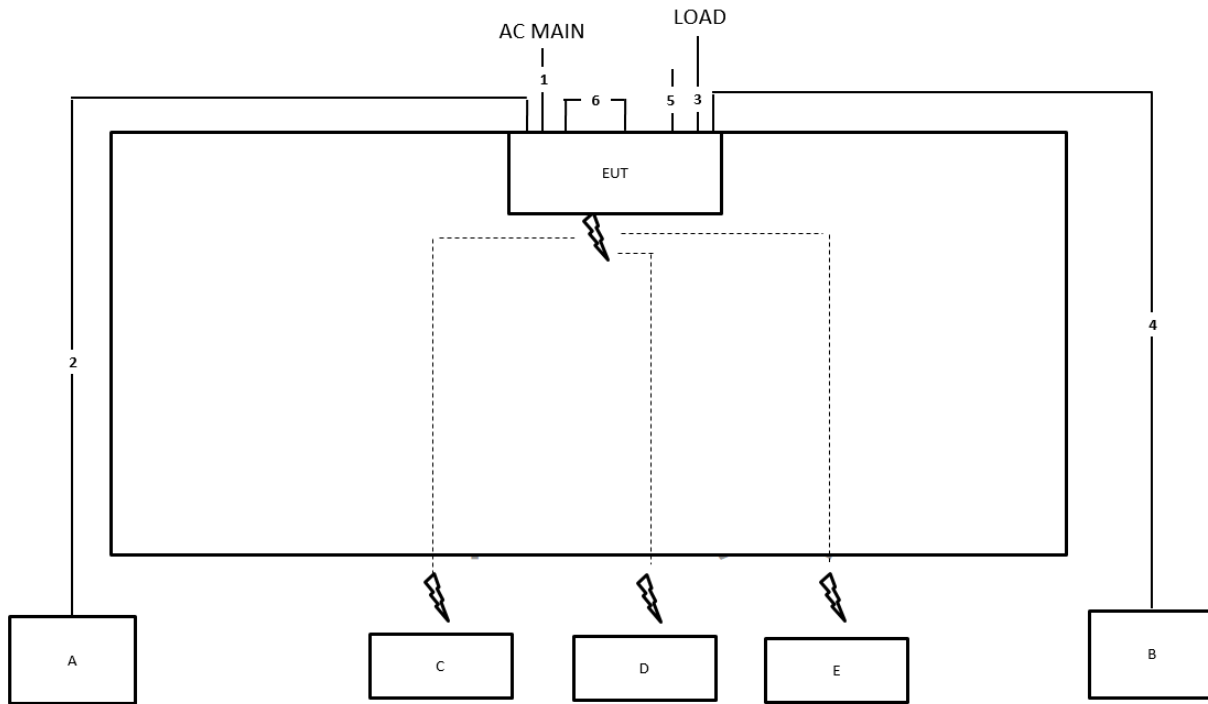

Item	Connection	Shielded	Length
1	Power cable	No	1.5m
2	RJ-45 cable	No	10m
3	RJ-45 cable*3	No	1.5m
4	RJ-45 cable	No	10m
5	Console cable	Yes	0.9m
6	RJ-45 cable	No	0.05m

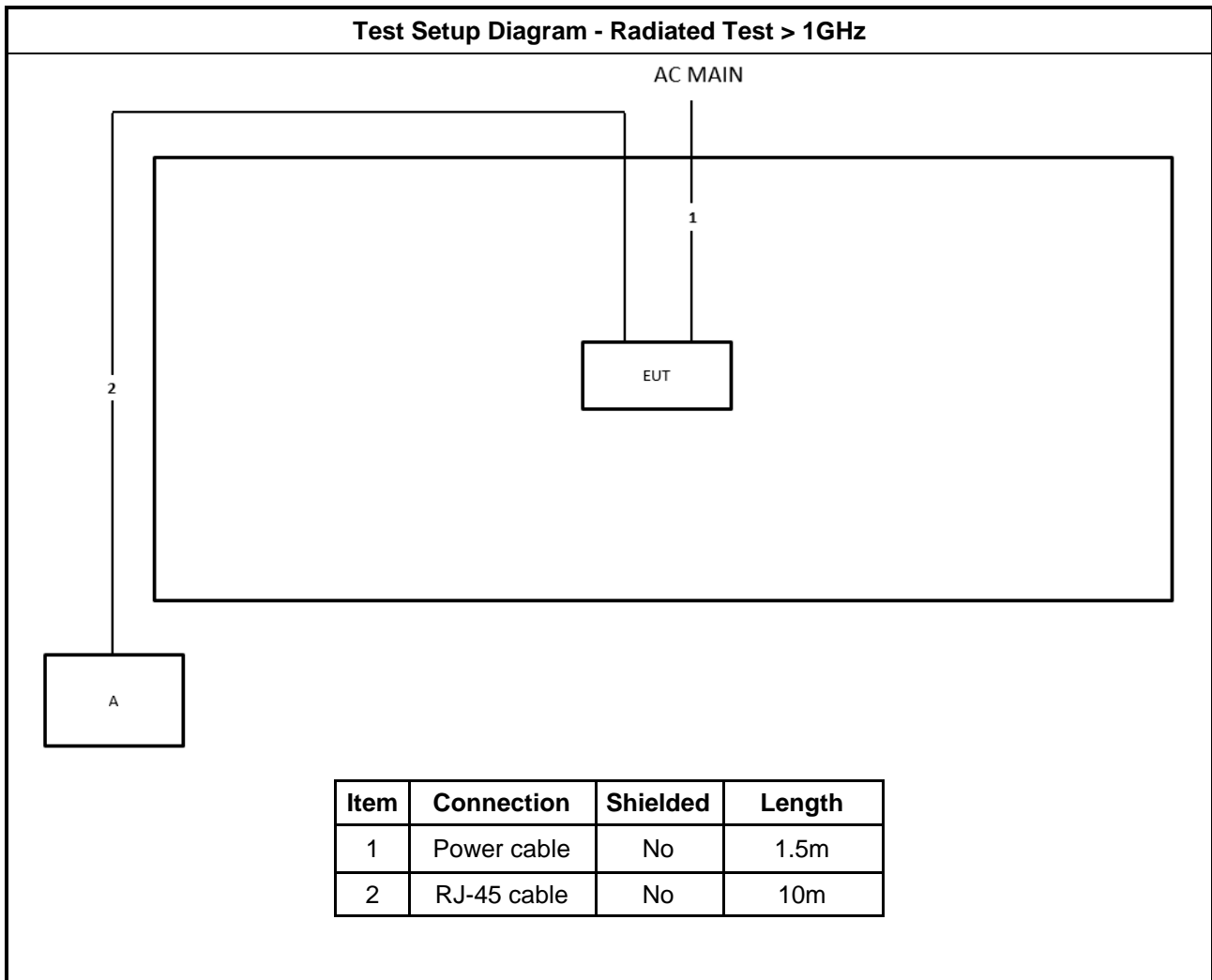



3 Transmitter Test Result

3.1 AC Power-line Conducted Emissions

3.1.1 AC Power-line Conducted Emissions Limit

AC Power-line Conducted Emissions Limit		
Frequency Emission (MHz)	Quasi-Peak	Average
0.15-0.5	66 - 56 *	56 - 46 *
0.5-5	56	46
5-30	60	50

Note 1: * Decreases with the logarithm of the frequency.

3.1.2 Measuring Instruments

Refer a test equipment and calibration data table in this test report.

3.1.3 Test Procedures

Test Method
<input checked="" type="checkbox"/> Refer as ANSI C63.10-2013, clause 6.2 for AC power-line conducted emissions.

3.1.4 Test Setup

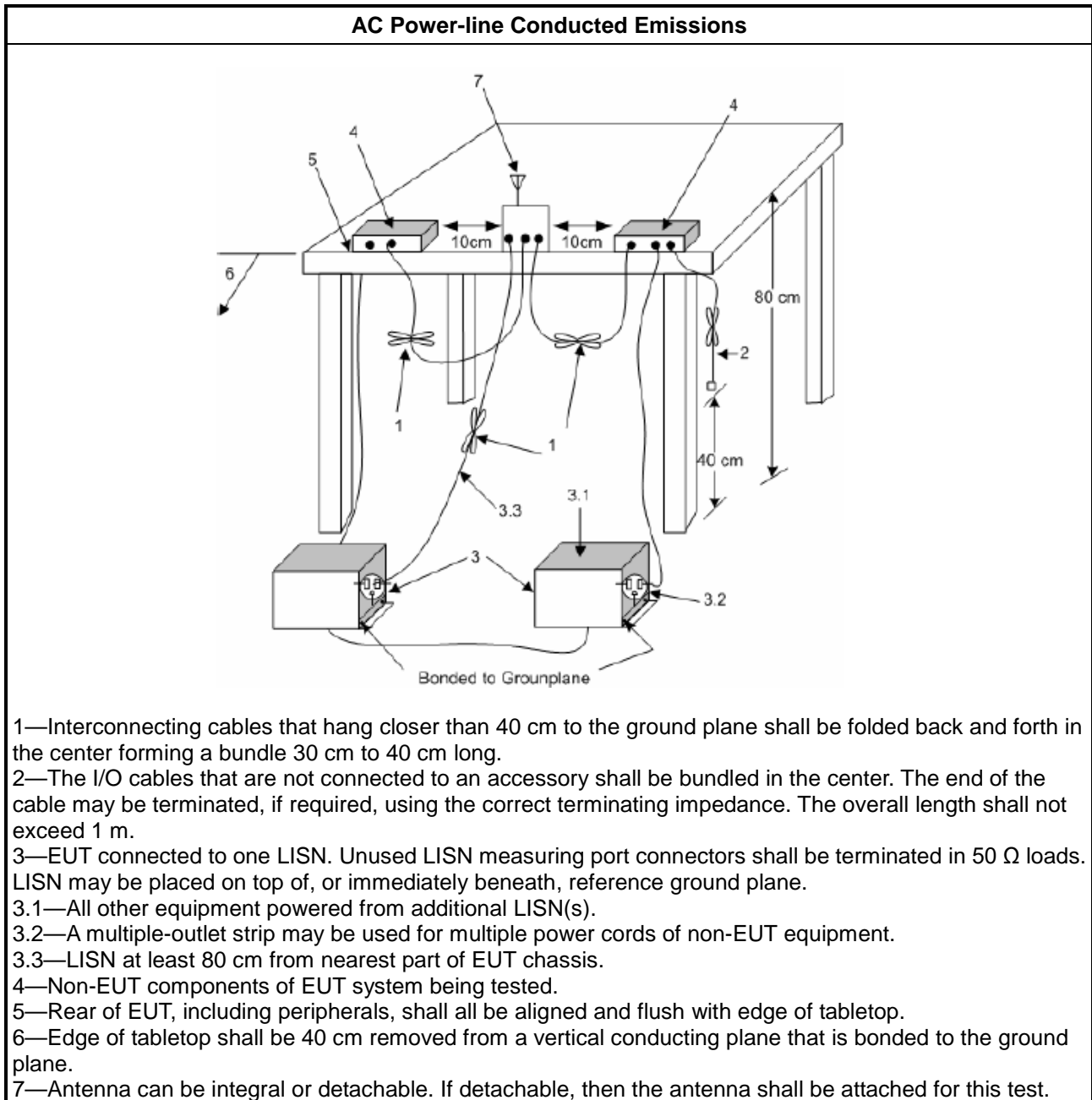

3.1.5 Measurement Results Calculation

The measured Level is calculated using:

- a. Corrected Reading: LISN Factor (LISN) + Attenuator (AT/AUX) + Cable Loss (CL) + Read Level (Raw) = Level
- b. Margin = -Limit + Level

3.1.6 Test Result of AC Power-line Conducted Emissions

Refer as Appendix A

3.2 DTS Bandwidth

3.2.1 6dB Bandwidth Limit

6dB Bandwidth Limit
Systems using digital modulation techniques:
<ul style="list-style-type: none"> ▪ 6 dB bandwidth \geq 500 kHz.

3.2.2 Measuring Instruments

Refer a test equipment and calibration data table in this test report.

3.2.3 Test Procedures

Test Method
<ul style="list-style-type: none"> ▪ For the emission bandwidth shall be measured using one of the options below:
<input checked="" type="checkbox"/> Refer as FCC KDB 558074, clause 8.2 & C63.10 clause 11.8.1 Option 1 for 6 dB bandwidth measurement.
<input type="checkbox"/> Refer as FCC KDB 558074, clause 8.2 & C63.10 clause 11.8.2 Option 2 for 6 dB bandwidth measurement.
<input type="checkbox"/> Refer as ANSI C63.10, clause 6.9.1 for occupied bandwidth testing.

3.2.4 Test Setup

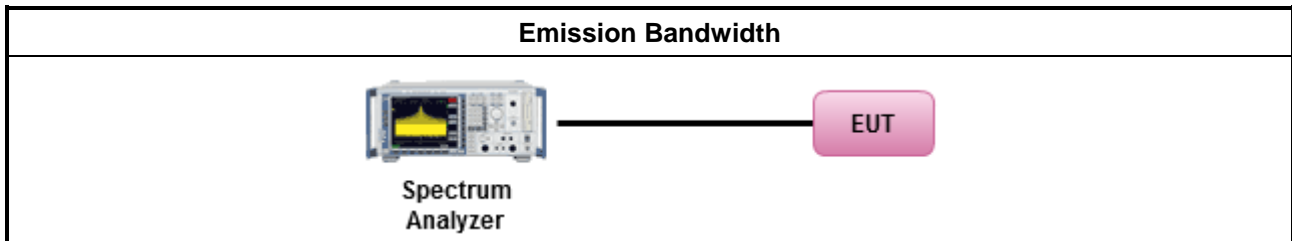

3.2.5 Test Result of Emission Bandwidth

Refer as Appendix B



3.3 Maximum Conducted Output Power

3.3.1 Maximum Conducted Output Power Limit

Maximum Conducted Output Power Limit	
	<ul style="list-style-type: none"> ▪ If $G_{TX} \leq 6$ dBi, then $P_{Out} \leq 30$ dBm (1 W)
	<ul style="list-style-type: none"> ▪ Point-to-multipoint systems (P2M): If $G_{TX} > 6$ dBi, then $P_{Out} = 30 - (G_{TX} - 6)$ dBm
	<ul style="list-style-type: none"> ▪ Point-to-point systems (P2P): If $G_{TX} > 6$ dBi, then $P_{Out} = 30 - (G_{TX} - 6)/3$ dBm
	<ul style="list-style-type: none"> ▪ Smart antenna system (SAS):
	<ul style="list-style-type: none"> - Single beam: If $G_{TX} > 6$ dBi, then $P_{Out} = 30 - (G_{TX} - 6)/3$ dBm
	<ul style="list-style-type: none"> - Overlap beam: If $G_{TX} > 6$ dBi, then $P_{Out} = 30 - (G_{TX} - 6)/3$ dBm
	<ul style="list-style-type: none"> - Aggregate power on all beams: If $G_{TX} > 6$ dBi, then $P_{Out} = 30 - (G_{TX} - 6)/3 + 8$ dB dBm
P_{Out} = maximum peak conducted output power or maximum conducted output power in dBm, G_{TX} = the maximum transmitting antenna directional gain in dBi.	

3.3.2 Measuring Instruments

Refer a test equipment and calibration data table in this test report.



3.3.3 Test Procedures

Test Method	
<ul style="list-style-type: none"> ▪ Maximum Peak Conducted Output Power 	
	<input type="checkbox"/> Refer as FCC KDB 558074, clause 8.3.1.1 & C63.10 clause 11.9.1.1 (RBW ≥ EBW method).
	<input type="checkbox"/> Refer as FCC KDB 558074, clause 8.3.1.3 & C63.10 clause 11.9.1.3 (peak power meter).
<ul style="list-style-type: none"> ▪ Maximum Conducted Output Power 	
[duty cycle ≥ 98% or external video / power trigger]	
	<input type="checkbox"/> Refer as FCC KDB 558074, clause 8.3.2.2 & C63.10 clause 11.9.2.2.2 Method AVGSA-1.
	<input type="checkbox"/> Refer as FCC KDB 558074, clause 8.3.2.2 & C63.10 clause 11.9.2.2.3 Method AVGSA-1A. (alternative)
duty cycle < 98% and average over on/off periods with duty factor	
	<input type="checkbox"/> Refer as FCC KDB 558074, clause 8.3.2.2 & C63.10 clause 11.9.2.2.4 Method AVGSA-2.
	<input type="checkbox"/> Refer as FCC KDB 558074, clause 8.3.2.2 & C63.10 clause 11.9.2.2.5 Method AVGSA-2A (alternative)
	<input type="checkbox"/> Refer as FCC KDB 558074, clause 8.3.2.2 & C63.10 clause 11.9.2.2.6 Method AVGSA-3
	<input type="checkbox"/> Refer as FCC KDB 558074, clause 8.3.2.2 & C63.10 clause 11.9.2.2.7 Method AVGSA-3A (alternative)
Measurement using a power meter (PM)	
	<input type="checkbox"/> Refer as FCC KDB 558074, clause 8.3.2.3 & C63.10 clause 11.9.2.3.1 Method AVGPM (using an RF average power meter).
	<input checked="" type="checkbox"/> Refer as FCC KDB 558074, clause 8.3.2.3 & C63.10 clause 11.9.2.3.2 Method AVGPM-G (using an gate RF average power meter).
<ul style="list-style-type: none"> ▪ For conducted measurement. 	
	<ul style="list-style-type: none"> ▪ If the EUT supports multiple transmit chains using options given below: Refer as FCC KDB 662911, In-band power measurements. Using the measure-and-sum approach, measured all transmit ports individually. Sum the power (in linear power units e.g., mW) of all ports for each individual sample and save them.
	<ul style="list-style-type: none"> ▪ If multiple transmit chains, EIRP calculation could be following as methods: $P_{total} = P_1 + P_2 + \dots + P_n$ (calculated in linear unit [mW] and transfer to log unit [dBm]) $EIRP_{total} = P_{total} + DG$

3.3.4 Test Setup

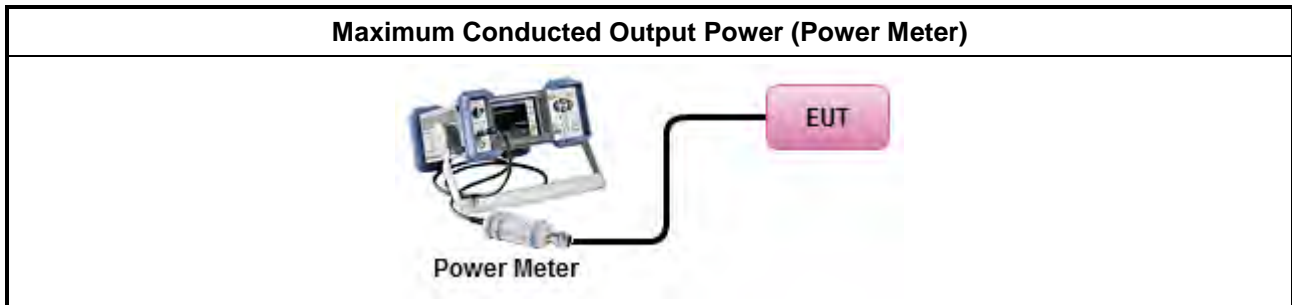

3.3.5 Test Result of Maximum Conducted Output Power

Refer as Appendix C



3.4 Power Spectral Density

3.4.1 Power Spectral Density Limit

Power Spectral Density Limit
<ul style="list-style-type: none"> Power Spectral Density (PSD) \leq 8 dBm/3kHz

3.4.2 Measuring Instruments

Refer a test equipment and calibration data table in this test report.

3.4.3 Test Procedures

Test Method			
<ul style="list-style-type: none"> Peak power spectral density procedures that the same method as used to determine the conducted output power. If maximum peak conducted output power was measured to demonstrate compliance to the output power limit, then the peak PSD procedure below (Method PKPSD) shall be used. If maximum conducted output power was measured to demonstrate compliance to the output power limit, then one of the average PSD procedures shall be used, as applicable based on the following criteria (the peak PSD procedure is also an acceptable option). 			
<input checked="" type="checkbox"/> Refer as FCC KDB 558074, clause 8.4 & C63.10 clause 11.10 Method Max. PSD.			
<ul style="list-style-type: none"> For conducted measurement. <ul style="list-style-type: none"> If The EUT supports multiple transmit chains using options given below: <table border="1"> <tbody> <tr> <td> <input checked="" type="checkbox"/> Option 1: Measure and sum the spectra across the outputs. Refer as FCC KDB 662911, In-band power spectral density (PSD). Sample all transmit ports simultaneously using a spectrum analyzer for each transmit port. Where the trace bin-by-bin of each transmit port summing can be performed. (i.e., in the first spectral bin of output 1 is summed with that in the first spectral bin of output 2 and that from the first spectral bin of output 3, and so on up to the NTX output to obtain the value for the first frequency bin of the summed spectrum.). Add up the amplitude (power) values for the different transmit chains and use this as the new data trace. </td> </tr> <tr> <td> <input type="checkbox"/> Option 2: Measure and sum spectral maxima across the outputs. With this technique, spectra are measured at each output of the device at the required resolution bandwidth. The maximum value (peak) of each spectrum is determined. These maximum values are then summed mathematically in linear power units across the outputs. These operations shall be performed separately over frequency spans that have different out-of-band or spurious emission limits, </td> </tr> <tr> <td> <input type="checkbox"/> Option 3: Measure and add 10 log(N) dB, where N is the number of transmit chains. Refer as FCC KDB 662911, In-band power spectral density (PSD). Performed at each transmit chains and each transmit chains shall be compared with the limit have been reduced with 10 log(N). Or each transmit chains shall be add 10 log(N) to compared with the limit. </td> </tr> </tbody> </table> 	<input checked="" type="checkbox"/> Option 1: Measure and sum the spectra across the outputs. Refer as FCC KDB 662911, In-band power spectral density (PSD). Sample all transmit ports simultaneously using a spectrum analyzer for each transmit port. Where the trace bin-by-bin of each transmit port summing can be performed. (i.e., in the first spectral bin of output 1 is summed with that in the first spectral bin of output 2 and that from the first spectral bin of output 3, and so on up to the NTX output to obtain the value for the first frequency bin of the summed spectrum.). Add up the amplitude (power) values for the different transmit chains and use this as the new data trace.	<input type="checkbox"/> Option 2: Measure and sum spectral maxima across the outputs. With this technique, spectra are measured at each output of the device at the required resolution bandwidth. The maximum value (peak) of each spectrum is determined. These maximum values are then summed mathematically in linear power units across the outputs. These operations shall be performed separately over frequency spans that have different out-of-band or spurious emission limits,	<input type="checkbox"/> Option 3: Measure and add 10 log(N) dB, where N is the number of transmit chains. Refer as FCC KDB 662911, In-band power spectral density (PSD). Performed at each transmit chains and each transmit chains shall be compared with the limit have been reduced with 10 log(N). Or each transmit chains shall be add 10 log(N) to compared with the limit.
<input checked="" type="checkbox"/> Option 1: Measure and sum the spectra across the outputs. Refer as FCC KDB 662911, In-band power spectral density (PSD). Sample all transmit ports simultaneously using a spectrum analyzer for each transmit port. Where the trace bin-by-bin of each transmit port summing can be performed. (i.e., in the first spectral bin of output 1 is summed with that in the first spectral bin of output 2 and that from the first spectral bin of output 3, and so on up to the NTX output to obtain the value for the first frequency bin of the summed spectrum.). Add up the amplitude (power) values for the different transmit chains and use this as the new data trace.			
<input type="checkbox"/> Option 2: Measure and sum spectral maxima across the outputs. With this technique, spectra are measured at each output of the device at the required resolution bandwidth. The maximum value (peak) of each spectrum is determined. These maximum values are then summed mathematically in linear power units across the outputs. These operations shall be performed separately over frequency spans that have different out-of-band or spurious emission limits,			
<input type="checkbox"/> Option 3: Measure and add 10 log(N) dB, where N is the number of transmit chains. Refer as FCC KDB 662911, In-band power spectral density (PSD). Performed at each transmit chains and each transmit chains shall be compared with the limit have been reduced with 10 log(N). Or each transmit chains shall be add 10 log(N) to compared with the limit.			

3.4.4 Test Setup

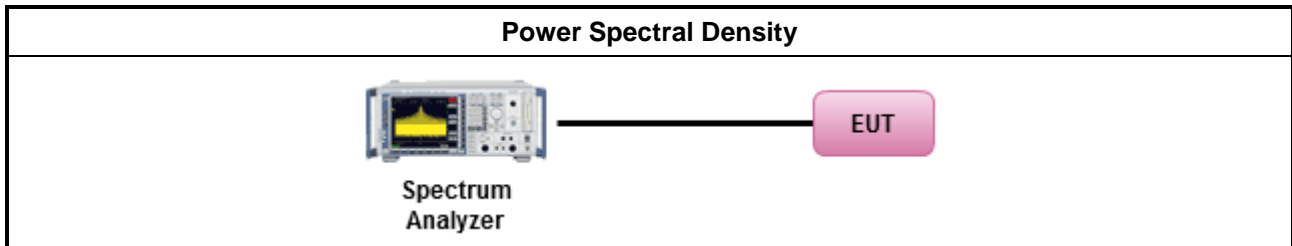

3.4.5 Test Result of Power Spectral Density

Refer as Appendix D

3.5 Emissions in Non-restricted Frequency Bands

3.5.1 Emissions in Non-restricted Frequency Bands Limit

Un-restricted Band Emissions Limit	
RF output power procedure	Limit (dBc)
Peak output power procedure	20
Average output power procedure	30

Note 1: If the peak output power procedure is used to measure the fundamental emission power to demonstrate compliance to requirements, then the peak conducted output power measured within any 100 kHz outside the authorized frequency band shall be attenuated by at least 20 dB relative to the maximum measured in-band peak PSD level.

Note 2: If the average output power procedure is used to measure the fundamental emission power to demonstrate compliance to requirements, then the power in any 100 kHz outside of the authorized frequency band shall be attenuated by at least 30 dB relative to the maximum measured in-band average PSD level.

3.5.2 Measuring Instruments

Refer a test equipment and calibration data table in this test report.

3.5.3 Test Procedures

Test Method
<ul style="list-style-type: none"> Refer as FCC KDB 558074, clause 8.5 for unwanted emissions into non-restricted bands.

3.5.4 Test Setup

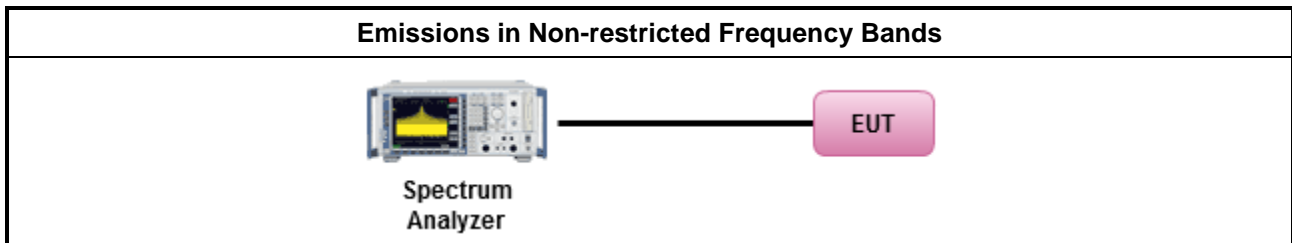

3.5.5 Test Result of Emissions in Non-restricted Frequency Bands

Refer as Appendix E



3.6 Emissions in Restricted Frequency Bands

3.6.1 Emissions in Restricted Frequency Bands Limit

Restricted Band Emissions Limit			
Frequency Range (MHz)	Field Strength (uV/m)	Field Strength (dBuV/m)	Measure Distance (m)
0.009~0.490	2400/F(kHz)	48.5 - 13.8	300
0.490~1.705	24000/F(kHz)	33.8 - 23	30
1.705~30.0	30	29	30
30~88	100	40	3
88~216	150	43.5	3
216~960	200	46	3
Above 960	500	54	3

Note 1: Test distance for frequencies at or above 30 MHz, measurements may be performed at a distance other than the limit distance provided they are not performed in the near field and the emissions to be measured can be detected by the measurement equipment. When performing measurements at a distance other than that specified, the results shall be extrapolated to the specified distance using an extrapolation factor of 20 dB/decade (inverse of linear distance for field-strength measurements, inverse of linear distance-squared for power-density measurements).

Note 2: Test distance for frequencies at below 30 MHz, measurements may be performed at a distance closer than the EUT limit distance; however, an attempt should be made to avoid making measurements in the near field. When performing measurements below 30 MHz at a closer distance than the limit distance, the results shall be extrapolated to the specified distance by either making measurements at a minimum of two or more distances on at least one radial to determine the proper extrapolation factor or by using the square of an inverse linear distance extrapolation factor (40 dB/decade). The test report shall specify the extrapolation method used to determine compliance of the EUT.

Note 3: Using the distance of 1m during the test for above 18 GHz, and the test value to correct for the distance factor at 3m.

3.6.2 Measuring Instruments

Refer a test equipment and calibration data table in this test report.



3.6.3 Test Procedures

Test Method	
<ul style="list-style-type: none"> ▪ The average emission levels shall be measured in [duty cycle \geq 98 or duty factor]. 	
<ul style="list-style-type: none"> ▪ Refer as ANSI C63.10, clause 6.10.3 band-edge testing shall be performed at the lowest frequency channel and highest frequency channel within the allowed operating band. 	
<ul style="list-style-type: none"> ▪ For the transmitter unwanted emissions shall be measured using following options below: 	
	<ul style="list-style-type: none"> ▪ Refer as FCC KDB 558074, clause 8.6 for unwanted emissions into restricted bands.
	<input type="checkbox"/> Refer as FCC KDB 558074, clause 8.6 & C63.10 clause 11.12.2.5.1(trace averaging for duty cycle \geq 98%).
	<input type="checkbox"/> Refer as FCC KDB 558074, clause 8.6 & C63.10 clause 11.12.2.5.2(trace averaging + duty factor).
	<input checked="" type="checkbox"/> Refer as FCC KDB 558074, clause 8.6 & C63.10 clause 11.12.2.5.3(Reduced VBW \geq 1/T).
	<input type="checkbox"/> Refer as ANSI C63.10, clause 11.12.2.5.3 (Reduced VBW). VBW \geq 1/T, where T is pulse time.
	<input type="checkbox"/> Refer as ANSI C63.10, clause 7.5 average value of pulsed emissions.
	<input checked="" type="checkbox"/> Refer as FCC KDB 558074, clause 8.6 & C63.10 clause 11.12.2.4 measurement procedure peak limit.
<ul style="list-style-type: none"> ▪ For the transmitter band-edge emissions shall be measured using following options below: 	
	<ul style="list-style-type: none"> ▪ Refer as FCC KDB 558074 clause 8.7 & C63.10 clause 11.13.1, When the performing peak or average radiated measurements, emissions within 2 MHz of the authorized band edge may be measured using the marker-delta method described below.
	<ul style="list-style-type: none"> ▪ Refer as FCC KDB 558074, clause 8.7 (ANSI C63.10, clause 6.10.6) for marker-delta method for band-edge measurements.
	<ul style="list-style-type: none"> ▪ Refer as FCC KDB 558074, clause 8.7 for narrower resolution bandwidth (100kHz) using the band power and summing the spectral levels (i.e., 1 MHz).
	<ul style="list-style-type: none"> ▪ For conducted unwanted emissions into restricted bands (absolute emission limits). Devices with multiple transmit chains using options given below: (1) Measure and sum the spectra across the outputs or (2) Measure and add 10 log(N) dB
	<ul style="list-style-type: none"> ▪ For FCC KDB 662911 The methodology described here may overestimate array gain, thereby resulting in apparent failures to satisfy the out-of-band limits even if the device is actually compliant. In such cases, compliance may be demonstrated by performing radiated tests around the frequencies at which the apparent failures occurred.

3.6.4 Test Setup

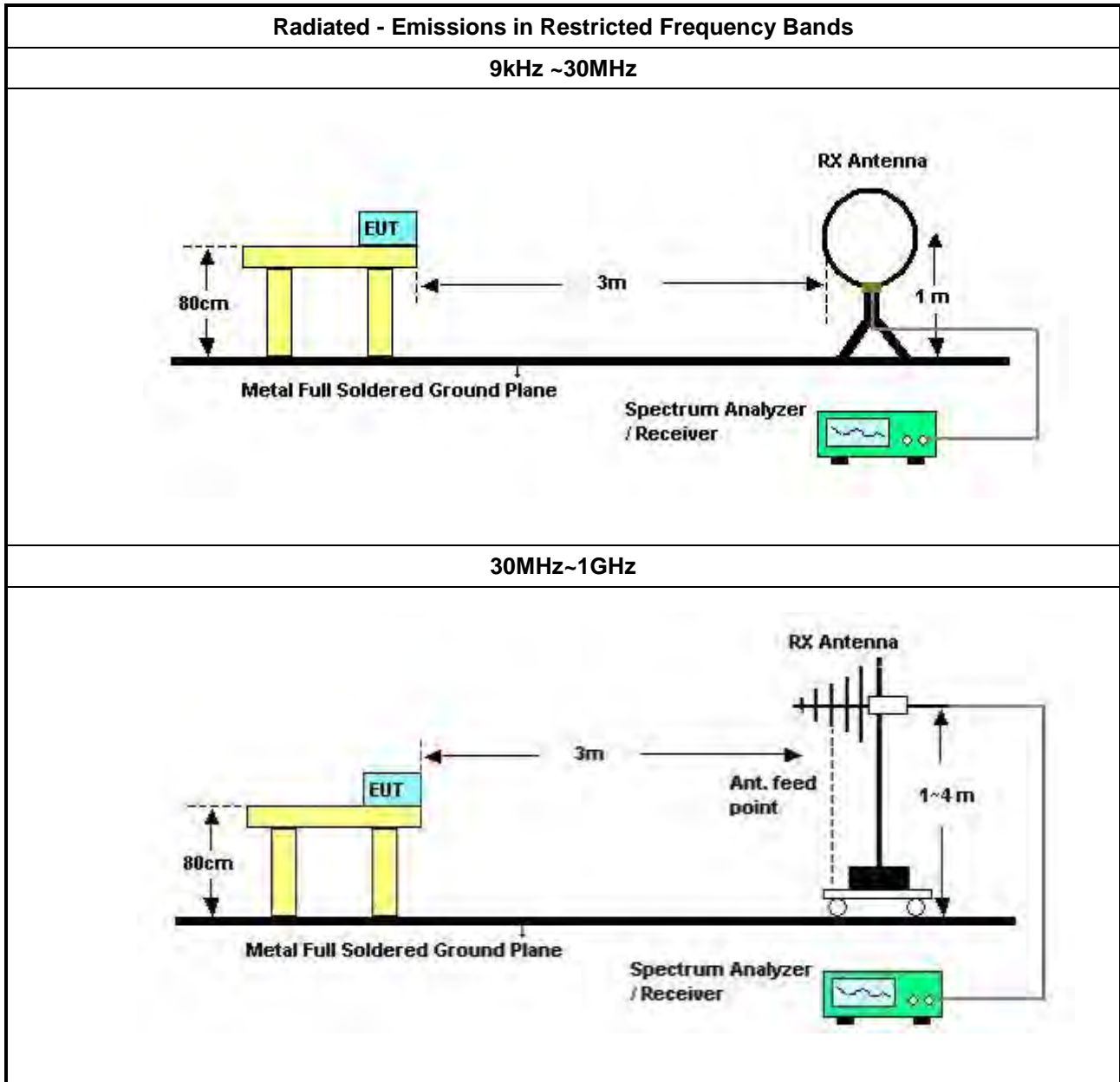

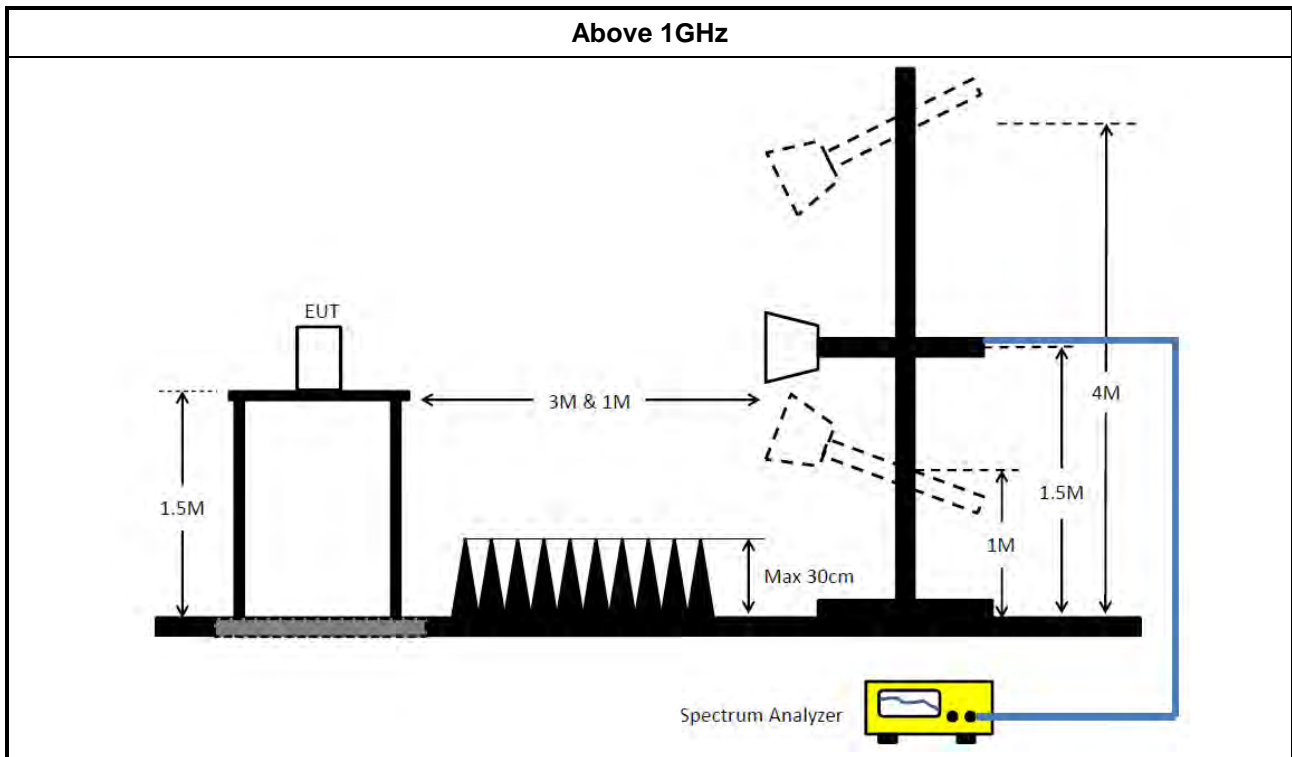

3.6.5 Measurement Results Calculation

The measured Level is calculated using:

Corrected Reading: Antenna factor (AF) + Cable loss (CL) + Read level (Raw) - Preamp factor (PA)(if applicable) = Level.

3.6.6 Emissions in Restricted Frequency Bands (Below 30MHz)

There is a comparison data of both open-field test site and alternative test site - semi-Anechoic chamber according to KDB414788 Radiated Test Site, and the result came out very similar.

All amplitude of spurious emissions that are attenuated by more than 20 dB below the permissible value has no need to be reported.

The radiated emissions were investigated from 9 kHz or the lowest frequency generated within the device, up to the 10th harmonic or 40 GHz, whichever is appropriate.

3.6.7 Test Result of Emissions in Restricted Frequency Bands

Refer as Appendix F



4 Test Equipment and Calibration Data

Instrument	Brand	Model No.	Serial No.	Characteristics	Calibration Date	Calibration Due Date	Remark
EMI Receiver	Agilent	N9038A	My52260123	9kHz ~ 8.4GHz	Feb. 22, 2022	Feb. 21, 2023	Conduction (CO01-CB)
LISN	F.C.C.	FCC-LISN-50-16-2	04083	150kHz ~ 100MHz	Feb. 09, 2022	Feb. 08, 2023	Conduction (CO01-CB)
LISN	Schwarzbeck	NSLK 8127	8127647	9kHz ~ 30MHz	Apr. 12, 2022	Apr. 11, 2023	Conduction (CO01-CB)
Pulse Limiter	Rohde & Schwarz	ESH3-Z2	100430	9kHz ~ 30MHz	Feb. 10, 2022	Feb. 09, 2023	Conduction (CO01-CB)
COND Cable	Woken	Cable	Low cable-CO01	9kHz ~ 30MHz	Oct. 18, 2022	Oct. 17, 2023	Conduction (CO01-CB)
Software	SPORTON	SENSE	V5.10	-	N.C.R.	N.C.R.	Conduction (CO01-CB)
Loop Antenna	Teseq	HLA 6120	24155	9kHz - 30 MHz	May 14, 2022	May 13, 2023	Radiation (03CH06-CB)
3m Semi Anechoic Chamber NSA	TDK	SAC-3M	03CH06-CB	30 MHz ~ 1 GHz	Aug. 04, 2022	Aug. 03, 2023	Radiation (03CH06-CB)
Bilog Antenna with 6 dB attenuator	TESEQ & EMCI	CBL6112D & N-6-06	37878 & AT-N0606	20MHz ~ 2GHz	Jul. 31, 2022	Jul. 30, 2023	Radiation (03CH06-CB)
Pre-Amplifier	Agilent	310N	187290	0.1MHz ~ 1GHz	Nov. 04, 2021	Nov. 03, 2022	Radiation (03CH06-CB)
Spectrum analyzer	R&S	FSP40	100080	9kHz~40GHz	Dec. 24, 2021	Dec. 23, 2022	Radiation (03CH06-CB)
EMI Test Receiver	R&S	ESCS	826547/017	9kHz ~ 2.75GHz	Jun. 17, 2022	Jun. 16, 2023	Radiation (03CH06-CB)
RF Cable-low	Woken	RG402	Low Cable-24+67	30MHz~1GHz	Oct. 03, 2022	Oct. 02, 2023	Radiation (03CH06-CB)
Test Software	SPORTON	SENSE	V5.10	-	N.C.R.	N.C.R.	Radiation (03CH06-CB)
3m Semi Anechoic Chamber VSWR	TDK	SAC-3M	03CH03-CB	1GHz ~18GHz 3m	May 05, 2022	May 04, 2023	Radiation (03CH03-CB)
Horn Antenna	ETS-Lindgren	3115	6821	750MHz~18GHz	Jan. 21, 2022	Jan. 20, 2023	Radiation (03CH03-CB)
Horn Antenna	Schwarzbeck	BBHA 9170	BBHA9170252	15GHz ~ 40GHz	Aug. 22, 2022	Aug. 21, 2023	Radiation (03CH03-CB)
Pre-Amplifier	Agilent	8449B	3008A02097	1GHz ~ 26.5GHz	Jul. 01, 2022	Jun. 30, 2023	Radiation (03CH03-CB)



Instrument	Brand	Model No.	Serial No.	Characteristics	Calibration Date	Calibration Due Date	Remark
Pre-Amplifier	MITEQ	TTA1840-35-H G	1864479	18GHz ~ 40GHz	Jul. 20, 2022	Jul. 19, 2023	Radiation (03CH03-CB)
Spectrum Analyzer	R&S	FSP40	100019	9kHz ~ 40GHz	Jun. 10, 2022	Jun. 09, 2023	Radiation (03CH03-CB)
RF Cable-high	Woken	RG402	High Cable-20+29	1GHz ~ 18GHz	Oct. 04, 2021	Oct. 03, 2022	Radiation (03CH03-CB)
RF Cable-high	Woken	RG402	High Cable-20+29	1GHz ~ 18GHz	Oct. 03, 2022	Oct. 02, 2023	Radiation (03CH03-CB)
RF Cable-high	Woken	RG402	High Cable-29	1GHz ~ 18GHz	Oct. 04, 2021	Oct. 03, 2022	Radiation (03CH03-CB)
RF Cable-high	Woken	RG402	High Cable-29	1GHz ~ 18GHz	Oct. 03, 2022	Oct. 02, 2023	Radiation (03CH03-CB)
High Cable	Woken	WCA0929M	40G#5+7	1GHz ~ 40 GHz	Dec. 14, 2021	Dec. 13, 2022	Radiation (03CH03-CB)
High Cable	Woken	WCA0929M	40G#5	1GHz ~ 40 GHz	Dec. 08, 2021	Dec. 07, 2022	Radiation (03CH03-CB)
High Cable	Woken	WCA0929M	40G#7	1GHz ~ 40 GHz	Dec. 14, 2021	Dec. 13, 2022	Radiation (03CH03-CB)
Test Software	SPORTON	SENSE	V5.10	-	N.C.R.	N.C.R.	Radiation (03CH03-CB)
Spectrum analyzer	R&S	FSV40	101028	9kHz~40GHz	Jan. 07, 2022	Jan. 06, 2023	Conducted (TH03-CB)
Power Sensor	Anritsu	MA2411B	1531344	300MHz~ 40GHz	Jul. 31, 2022	Jul. 30, 2023	Conducted (TH03-CB)
Power Meter	Anritsu	ML2495A	1728002	300MHz~ 40GHz	Jul. 31, 2022	Jul. 30, 2023	Conducted (TH03-CB)
RF Cable-high	Woken	RG402	High Cable-11	1 GHz ~18 GHz	Oct. 04, 2021	Oct. 03, 2022	Conducted (TH03-CB)
RF Cable-high	Woken	RG402	High Cable-11	1 GHz ~18 GHz	Oct. 03, 2022	Oct. 02, 2023	Conducted (TH03-CB)
RF Cable-high	Woken	RG402	High Cable-12	1 GHz ~18 GHz	Oct. 04, 2021	Oct. 03, 2022	Conducted (TH03-CB)
RF Cable-high	Woken	RG402	High Cable-12	1 GHz ~18 GHz	Oct. 03, 2022	Oct. 02, 2023	Conducted (TH03-CB)
RF Cable-high	Woken	RG402	High Cable-13	1 GHz ~18 GHz	Oct. 04, 2021	Oct. 03, 2022	Conducted (TH03-CB)
RF Cable-high	Woken	RG402	High Cable-13	1 GHz ~18 GHz	Oct. 03, 2022	Oct. 02, 2023	Conducted (TH03-CB)
RF Cable-high	Woken	RG402	High Cable-14	1 GHz ~18 GHz	Oct. 04, 2021	Oct. 03, 2022	Conducted (TH03-CB)
RF Cable-high	Woken	RG402	High Cable-14	1 GHz ~18 GHz	Oct. 03, 2022	Oct. 02, 2023	Conducted (TH03-CB)



Instrument	Brand	Model No.	Serial No.	Characteristics	Calibration Date	Calibration Due Date	Remark
RF Cable-high	Woken	RG402	High Cable-15	1 GHz –18 GHz	Oct. 04, 2021	Oct. 03, 2022	Conducted (TH03-CB)
RF Cable-high	Woken	RG402	High Cable-15	1 GHz –18 GHz	Oct. 03, 2022	Oct. 02, 2023	Conducted (TH03-CB)
Switch	SPTCB	SP-SWI	SWI-03	1 GHz – 26.5 GHz	Dec. 13, 2021	Dec. 12, 2022	Conducted (TH03-CB)
Test Software	SPORTON	SENSE	V5.10	-	N.C.R.	N.C.R.	Conducted (TH03-CB)

Note: Calibration Interval of instruments listed above is one year.

NCR means Non-Calibration required.



Summary

Mode	Result	Type	Freq (Hz)	Level (dBuV)	Limit (dBuV)	Margin (dB)	Condition
Mode 2	Pass	QP	154.5k	61.46	65.75	-4.29	Line

Mode 2

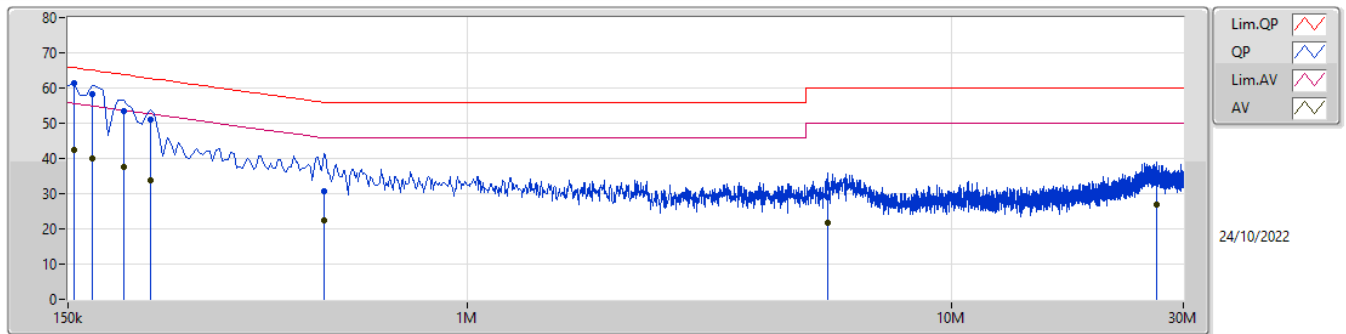

Type	Freq (Hz)	Level (dBuV)	Limit (dBuV)	Margin (dB)	Factor (dB)	Condition	Comment	Raw (dBuV)	LISN (dB)	CL (dB)	AT (dB)
QP	154.5k	61.46	65.75	-4.29	9.99	Line	"Worst"	51.47	0.06	0.04	9.89
AV	154.5k	42.54	55.75	-13.21	9.99	Line	-	32.55	0.06	0.04	9.89
QP	168k	58.29	65.06	-6.77	9.99	Line	-	48.30	0.06	0.04	9.89
AV	168k	39.97	55.06	-15.09	9.99	Line	-	29.98	0.06	0.04	9.89
QP	195k	53.30	63.82	-10.52	9.99	Line	-	43.31	0.06	0.04	9.89
AV	195k	37.52	53.82	-16.30	9.99	Line	-	27.53	0.06	0.04	9.89
QP	222k	51.01	62.75	-11.74	9.99	Line	-	41.02	0.06	0.04	9.89
AV	222k	33.93	52.75	-18.82	9.99	Line	-	23.94	0.06	0.04	9.89
QP	505.5k	30.83	56.00	-25.17	10.00	Line	-	20.83	0.06	0.05	9.89
AV	505.5k	22.50	46.00	-23.50	10.00	Line	-	12.50	0.06	0.05	9.89
QP	5.541M	29.10	60.00	-30.90	10.18	Line	-	18.92	0.16	0.12	9.90
AV	5.541M	21.67	50.00	-28.33	10.18	Line	-	11.49	0.16	0.12	9.90
QP	26.403M	33.24	60.00	-26.76	10.66	Line	-	22.58	0.37	0.30	9.99
AV	26.403M	26.82	50.00	-23.18	10.66	Line	-	16.16	0.37	0.30	9.99

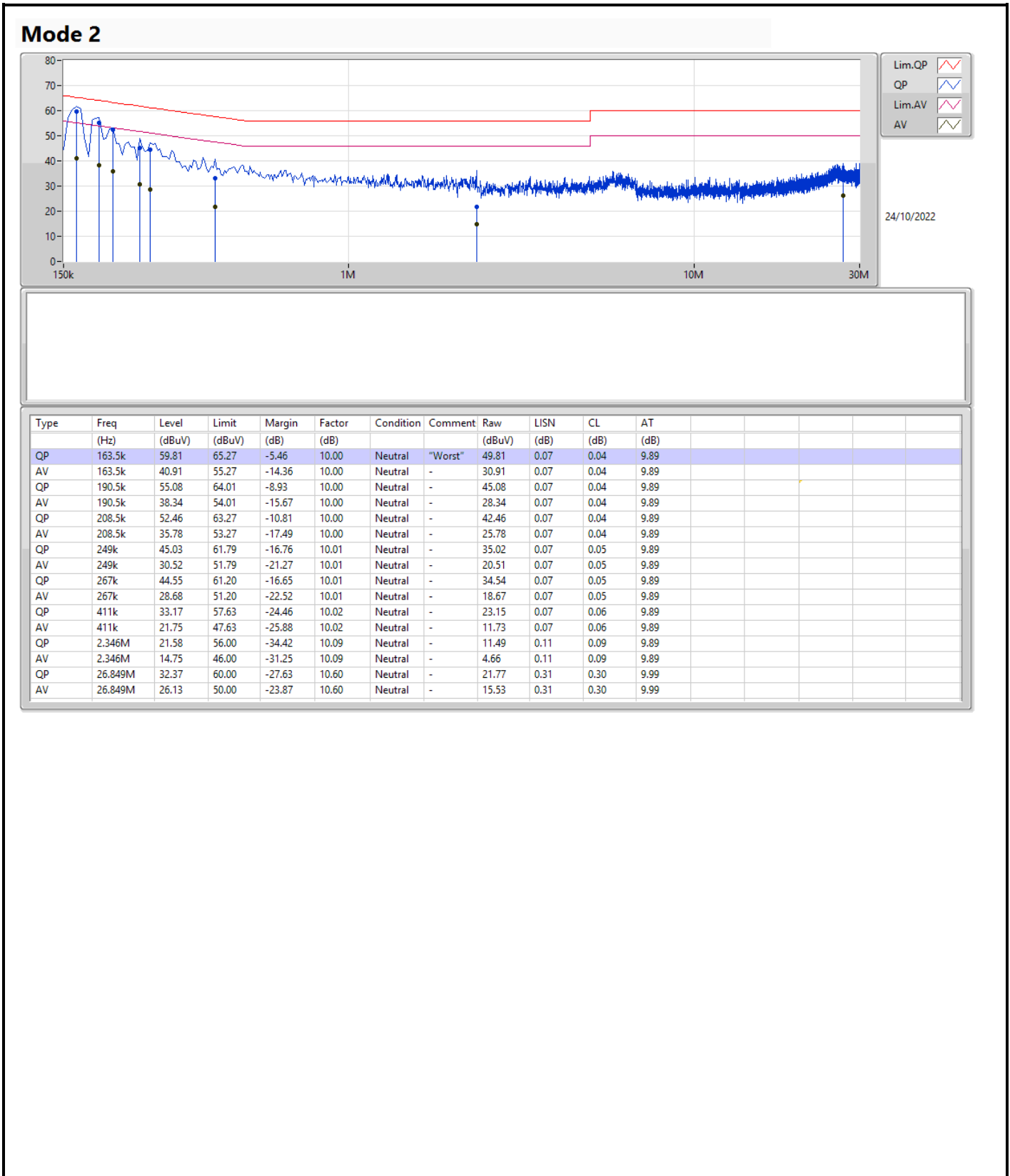



Summary

Mode	Max-N dB (Hz)	Max-OBW (Hz)	ITU-Code	Min-N dB (Hz)	Min-OBW (Hz)
2.4-2.4835GHz	-	-	-	-	-
802.11b_Nss1,(1Mbps)_2TX	8.05M	13.638M	13M6G1D	7.075M	12.942M
802.11g_Nss1,(6Mbps)_2TX	15.05M	17.14M	17M1D1D	13.775M	16.269M
802.11ax HEW20_Nss1,(MCS0)_2TX	15.575M	19.002M	19M0D1D	14.025M	18.807M
802.11ax HEW40_Nss1,(MCS0)_2TX	34.95M	37.564M	37M6D1D	22.65M	37.466M

Max-N dB = Maximum 6dB down bandwidth; Max-OBW = Maximum 99% occupied bandwidth;
Min-N dB = Minimum 6dB down bandwidth; Min-OBW = Minimum 99% occupied bandwidth

Result

Mode	Result	Limit (Hz)	Port 1-N dB (Hz)	Port 1-OBW (Hz)	Port 2-N dB (Hz)	Port 2-OBW (Hz)
802.11b_Nss1,(1Mbps)_2TX	-	-	-	-	-	-
2412MHz	Pass	500k	8.05M	13.159M	8.05M	12.942M
2437MHz	Pass	500k	7.075M	13.435M	7.1M	13.638M
2462MHz	Pass	500k	8.05M	13.058M	8.05M	13.014M
802.11g_Nss1,(6Mbps)_2TX	-	-	-	-	-	-
2412MHz	Pass	500k	14.975M	16.291M	13.775M	16.269M
2437MHz	Pass	500k	15.05M	17.14M	15M	16.694M
2462MHz	Pass	500k	15.025M	16.269M	13.825M	16.269M
802.11ax HEW20_Nss1,(MCS0)_2TX	-	-	-	-	-	-
2412MHz	Pass	500k	14.025M	18.856M	14.5M	18.831M
2437MHz	Pass	500k	15M	18.929M	15.575M	19.002M
2462MHz	Pass	500k	15M	18.831M	15.05M	18.807M
802.11ax HEW40_Nss1,(MCS0)_2TX	-	-	-	-	-	-
2422MHz	Pass	500k	22.65M	37.466M	34.65M	37.515M
2437MHz	Pass	500k	32.5M	37.466M	34.95M	37.564M
2452MHz	Pass	500k	34.25M	37.515M	32.3M	37.564M

Port X-N dB = Port X 6dB down bandwidth;
 Port X-OBW = Port X 99% occupied bandwidth

2.4-2.4835GHz_802.11b_Nss1,(1Mbps)_2TX
2412MHz

EBW

29/10/2022

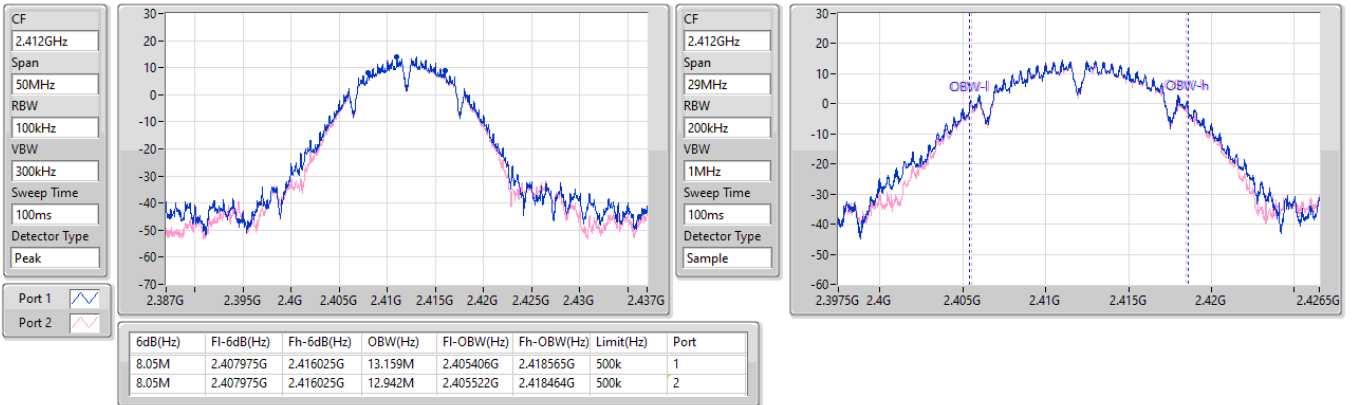

2.4-2.4835GHz_802.11b_Nss1,(1Mbps)_2TX
2437MHz

EBW

29/10/2022

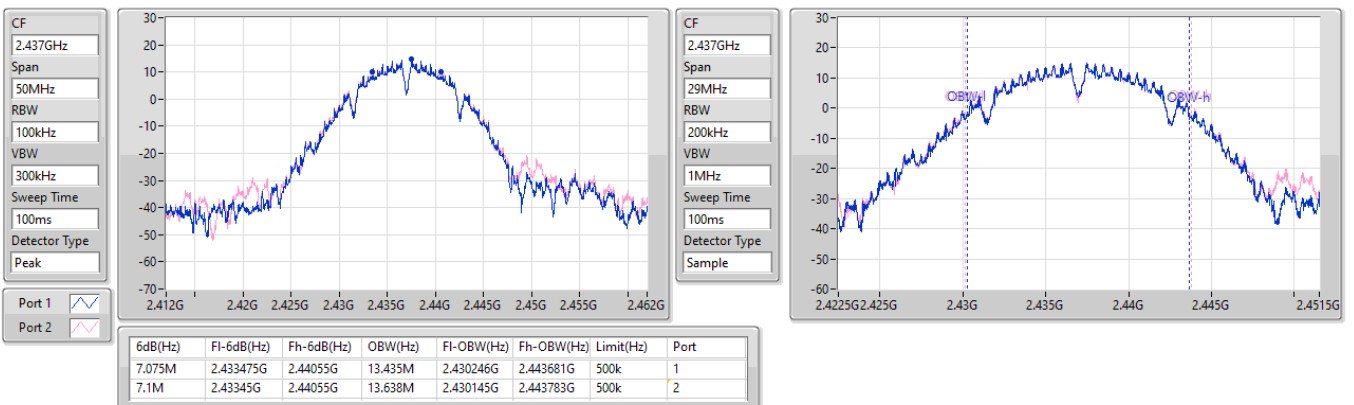

2.4-2.4835GHz_802.11b_Nss1,(1Mbps)_2TX
2462MHz

EBW

29/10/2022

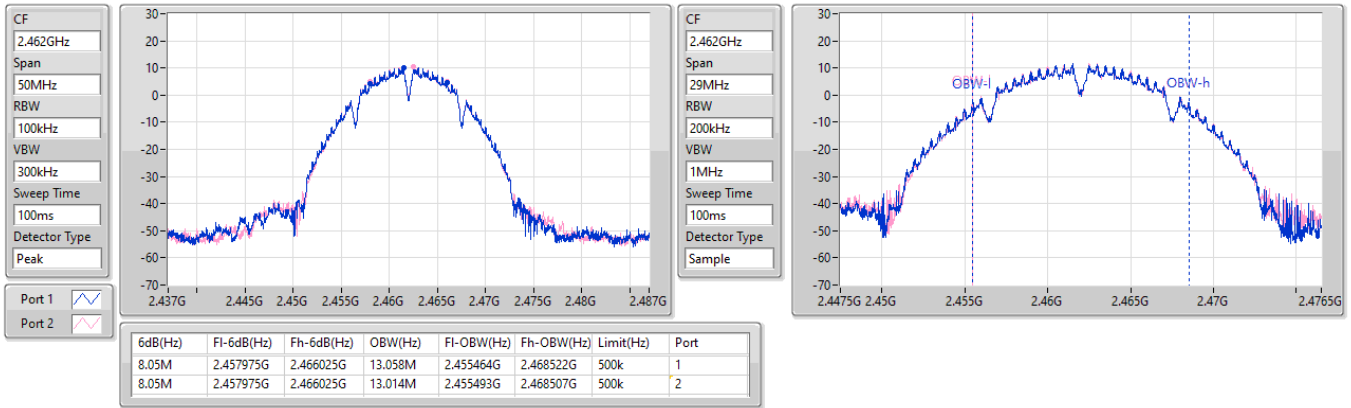

2.4-2.4835GHz_802.11g_Nss1,(6Mbps)_2TX
2412MHz

EBW

29/10/2022

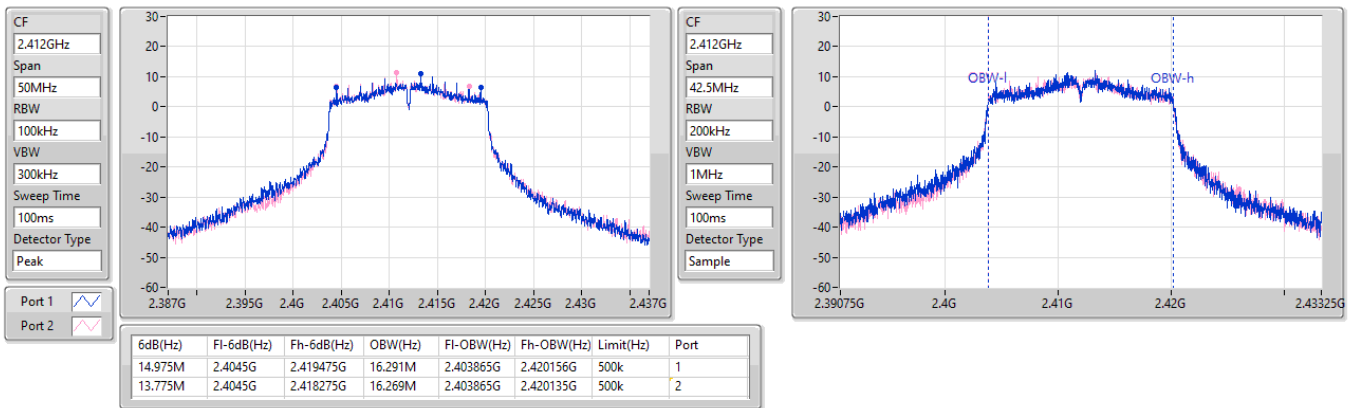

2.4-2.4835GHz_802.11g_Nss1,(6Mbps)_2TX
2437MHz

EBW

29/10/2022

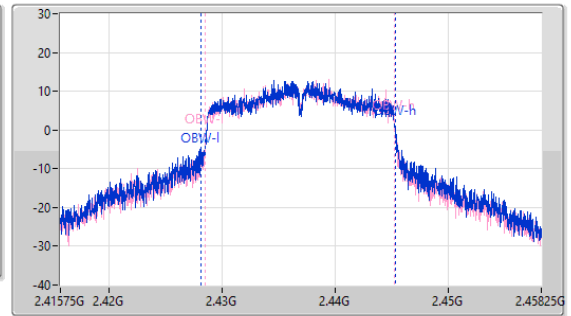
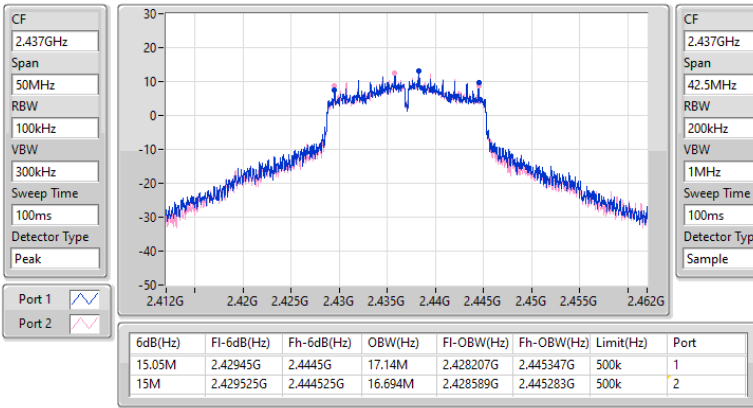

2.4-2.4835GHz_802.11g_Nss1,(6Mbps)_2TX
2462MHz

EBW

29/10/2022

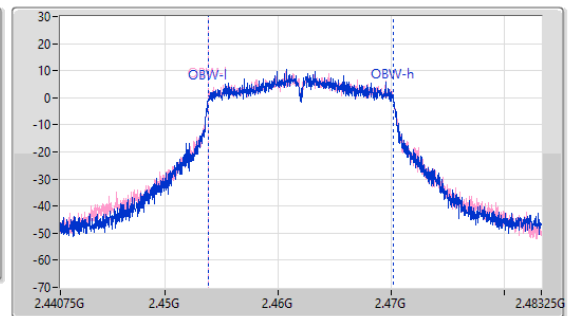
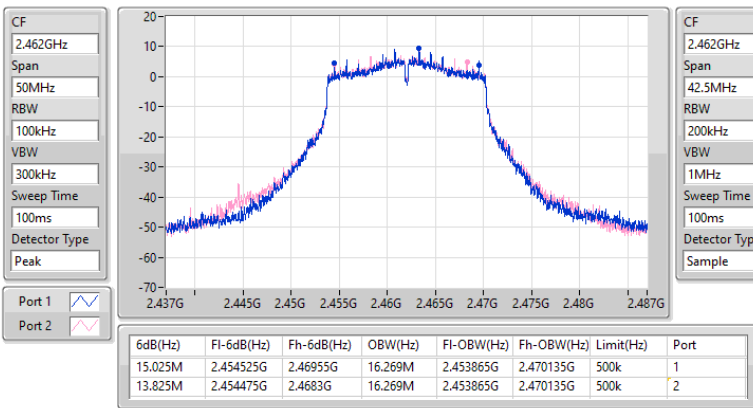

2.4-2.4835GHz_802.11ax HEW20_Nss1,(MCS0)_2TX
2412MHz

EBW

29/10/2022

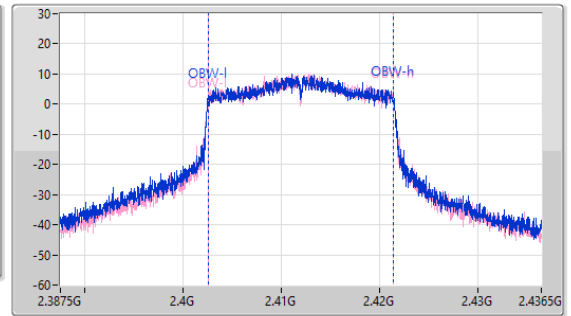
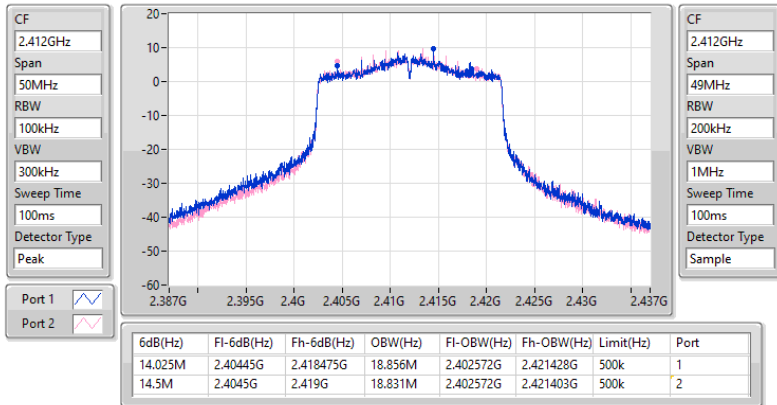

2.4-2.4835GHz_802.11ax HEW20_Nss1,(MCS0)_2TX
2437MHz

EBW

29/10/2022

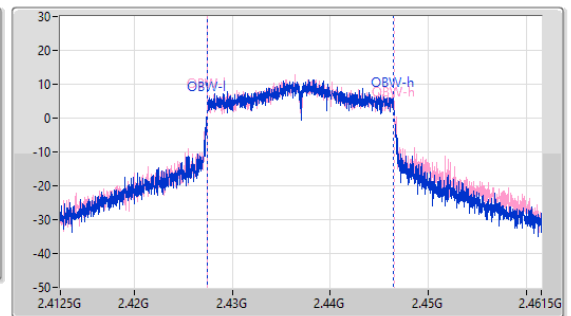
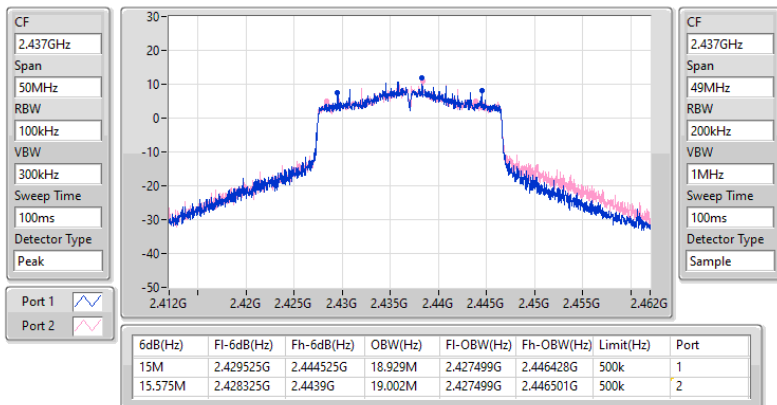

2.4-2.4835GHz_802.11ax HEW20_Nss1,(MCS0)_2TX
2462MHz

EBW

29/10/2022

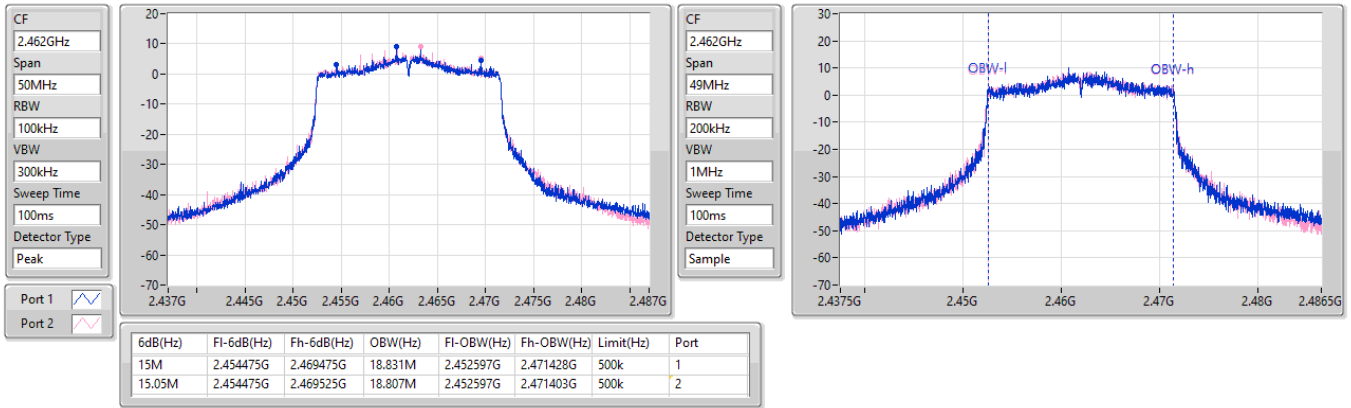

2.4-2.4835GHz_802.11ax HEW40_Nss1,(MCS0)_2TX
2422MHz

EBW

29/10/2022

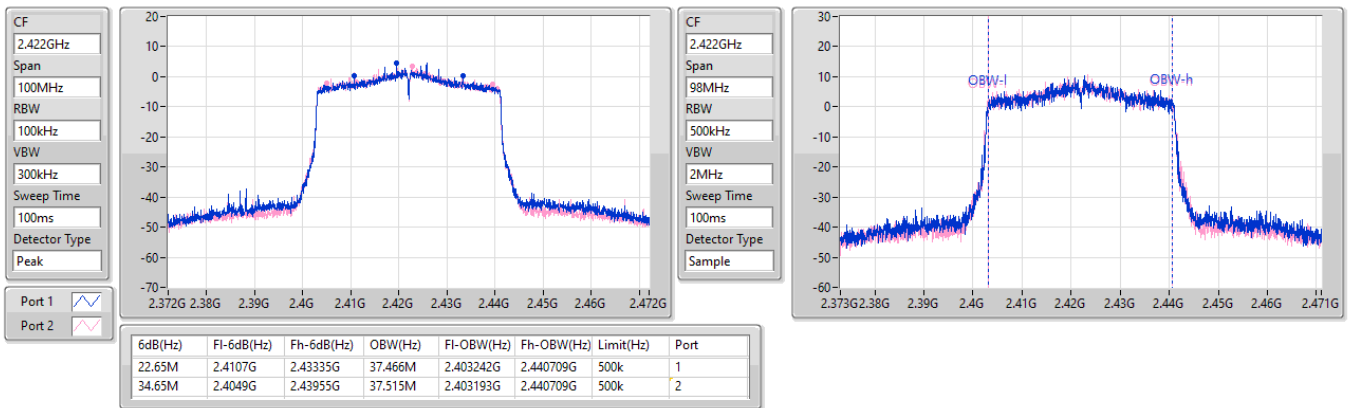

2.4-2.4835GHz_802.11ax HEW40_Nss1,(MCS0)_2TX
2437MHz

EBW

29/10/2022

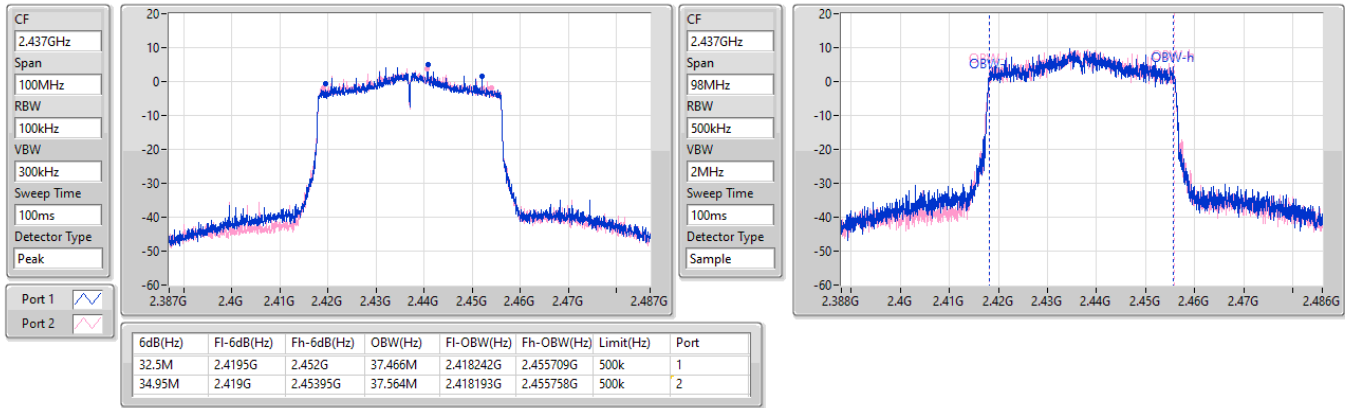

2.4-2.4835GHz_802.11ax HEW40_Nss1,(MCS0)_2TX
2452MHz

EBW

29/10/2022

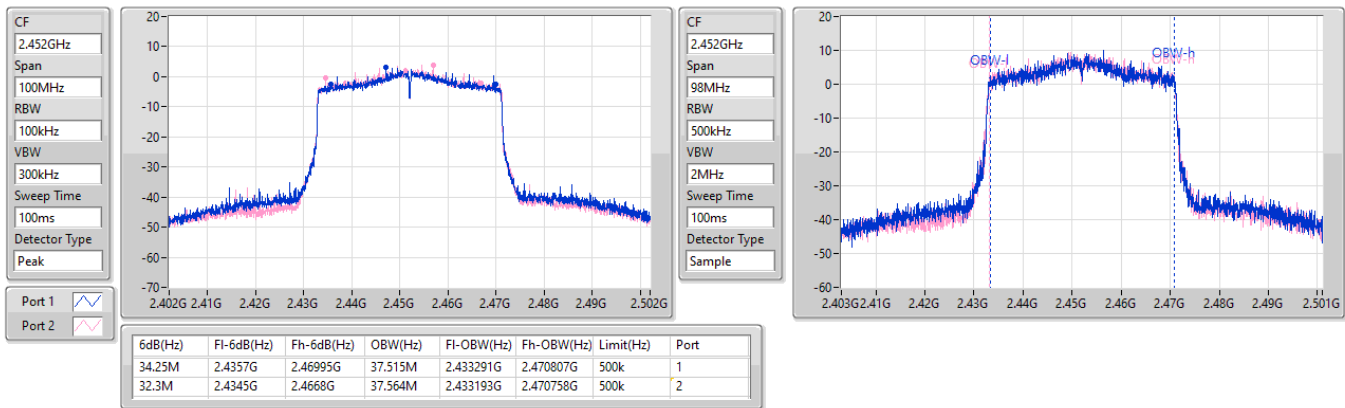



Summary

Mode	Total Power (dBm)	Total Power (W)
2.4-2.4835GHz	-	-
802.11b_Nss1,(1Mbps)_2TX	25.87	0.38637
802.11g_Nss1,(6Mbps)_2TX	25.04	0.31915
802.11ax HEW20_Nss1,(MCS0)_2TX	23.95	0.24831
802.11ax HEW20-BF_Nss1,(MCS0)_2TX	23.95	0.24831
802.11ax HEW40_Nss1,(MCS0)_2TX	20.63	0.11561
802.11ax HEW40-BF_Nss1,(MCS0)_2TX	20.63	0.11561



Result

Mode	Result	DG (dBi)	Port 1 (dBm)	Port 2 (dBm)	Total Power (dBm)	Power Limit (dBm)
802.11b_Nss1,(1Mbps)_2TX	-	-	-	-	-	-
2412MHz	Pass	3.94	22.22	22.13	25.19	30.00
2437MHz	Pass	3.94	22.8	22.91	25.87	30.00
2457MHz	Pass	3.94	19.19	19.29	22.25	30.00
2462MHz	Pass	3.94	19.06	19.17	22.13	30.00
802.11g_Nss1,(6Mbps)_2TX	-	-	-	-	-	-
2412MHz	Pass	3.94	19.94	20.00	22.98	30.00
2437MHz	Pass	3.94	22.02	22.04	25.04	30.00
2457MHz	Pass	3.94	18.16	18.39	21.29	30.00
2462MHz	Pass	3.94	18.14	18.47	21.32	30.00
802.11ax HEW20_Nss1,(MCS0)_2TX	-	-	-	-	-	-
2412MHz	Pass	3.94	19.36	19.38	22.38	30.00
2437MHz	Pass	3.94	20.96	20.92	23.95	30.00
2457MHz	Pass	3.94	18.47	18.62	21.56	30.00
2462MHz	Pass	3.94	18.02	18.28	21.16	30.00
802.11ax HEW40_Nss1,(MCS0)_2TX	-	-	-	-	-	-
2422MHz	Pass	3.94	16.98	17.12	20.06	30.00
2437MHz	Pass	3.94	17.45	17.79	20.63	30.00
2452MHz	Pass	3.94	17.03	17.44	20.25	30.00
802.11ax HEW20-BF_Nss1,(MCS0)_2TX	-	-	-	-	-	-
2412MHz	Pass	6.55	19.36	19.38	22.38	29.45
2437MHz	Pass	6.55	20.96	20.92	23.95	29.45
2457MHz	Pass	6.55	18.47	18.62	21.56	29.45
2462MHz	Pass	6.55	18.02	18.28	21.16	29.45
802.11ax HEW40-BF_Nss1,(MCS0)_2TX	-	-	-	-	-	-
2422MHz	Pass	6.55	16.98	17.12	20.06	29.45
2437MHz	Pass	6.55	17.45	17.79	20.63	29.45
2452MHz	Pass	6.55	17.03	17.44	20.25	29.45

DG = Directional Gain; Port X = Port X output power



Summary

Mode	PD (dBm/RBW)
2.4-2.4835GHz	-
802.11b_Nss1,(1Mbps)_2TX	2.76
802.11g_Nss1,(6Mbps)_2TX	-1.87
802.11ax HEW20_Nss1,(MCS0)_2TX	-1.93
802.11ax HEW40_Nss1,(MCS0)_2TX	-6.81

RBW = 3kHz;

Result

Mode	Result	DG (dBi)	Port 1 (dBm/RBW)	Port 2 (dBm/RBW)	PD (dBm/RBW)	PD Limit (dBm/RBW)
802.11b_Nss1,(1Mbps)_2TX	-	-	-	-	-	-
2412MHz	Pass	6.55	-1.53	-1.59	1.45	7.45
2437MHz	Pass	6.55	-0.36	-0.14	2.76	7.45
2462MHz	Pass	6.55	-5.01	-4.09	-1.92	7.45
802.11g_Nss1,(6Mbps)_2TX	-	-	-	-	-	-
2412MHz	Pass	6.55	-5.77	-5.86	-3.56	7.45
2437MHz	Pass	6.55	-2.94	-3.27	-1.87	7.45
2462MHz	Pass	6.55	-7.43	-7.50	-5.31	7.45
802.11ax HEW20_Nss1,(MCS0)_2TX	-	-	-	-	-	-
2412MHz	Pass	6.55	-3.35	-5.71	-1.93	7.45
2437MHz	Pass	6.55	-3.76	-3.97	-2.17	7.45
2462MHz	Pass	6.55	-6.22	-7.08	-4.43	7.45
802.11ax HEW40_Nss1,(MCS0)_2TX	-	-	-	-	-	-
2422MHz	Pass	6.55	-10.23	-9.49	-7.72	7.45
2437MHz	Pass	6.55	-9.75	-8.77	-6.96	7.45
2452MHz	Pass	6.55	-8.83	-8.30	-6.81	7.45

DG = Directional Gain; RBW = 3kHz;
 PD = trace bin-by-bin of each transmits port summing can be performed maximum power density; Port X = Port X Power Density;

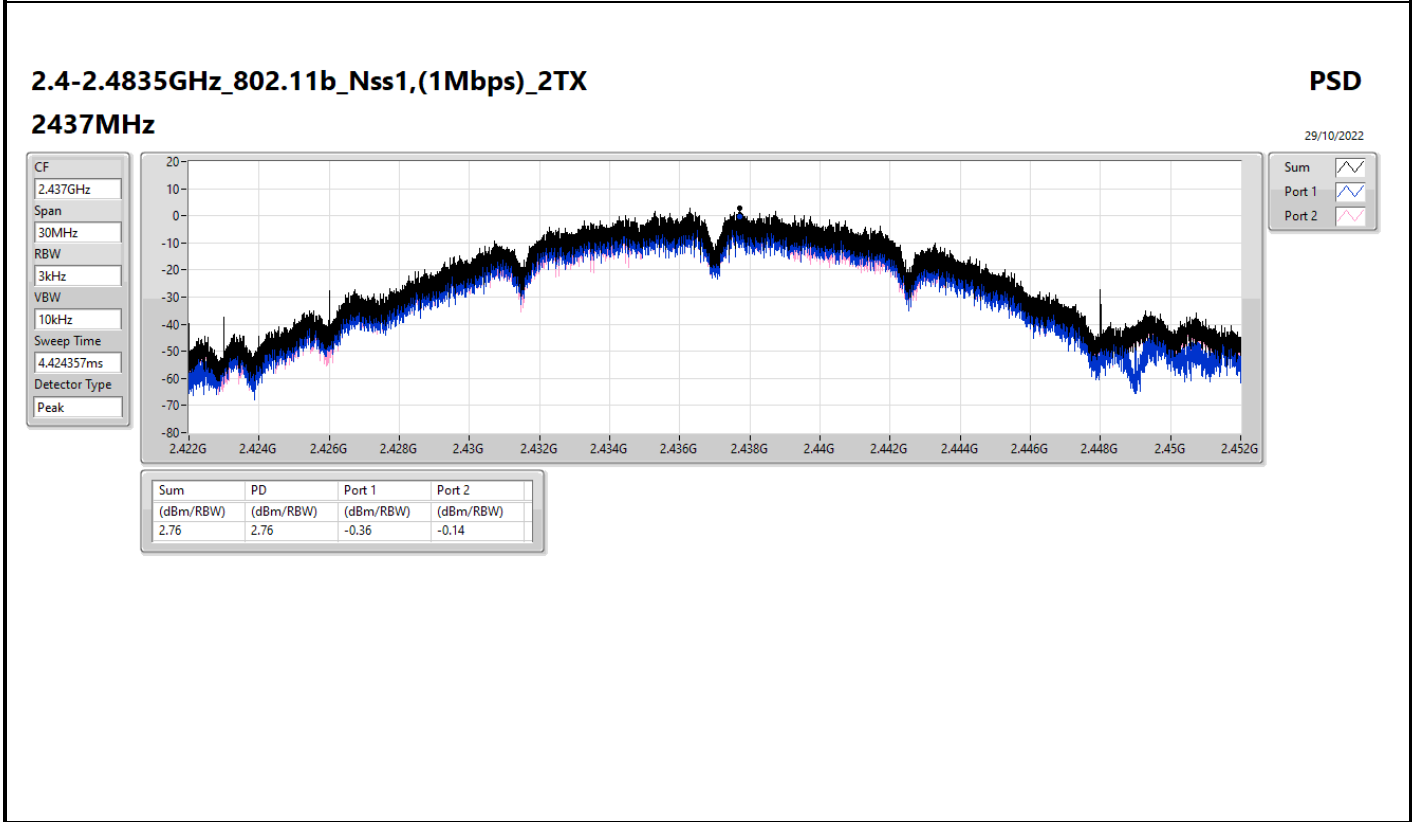
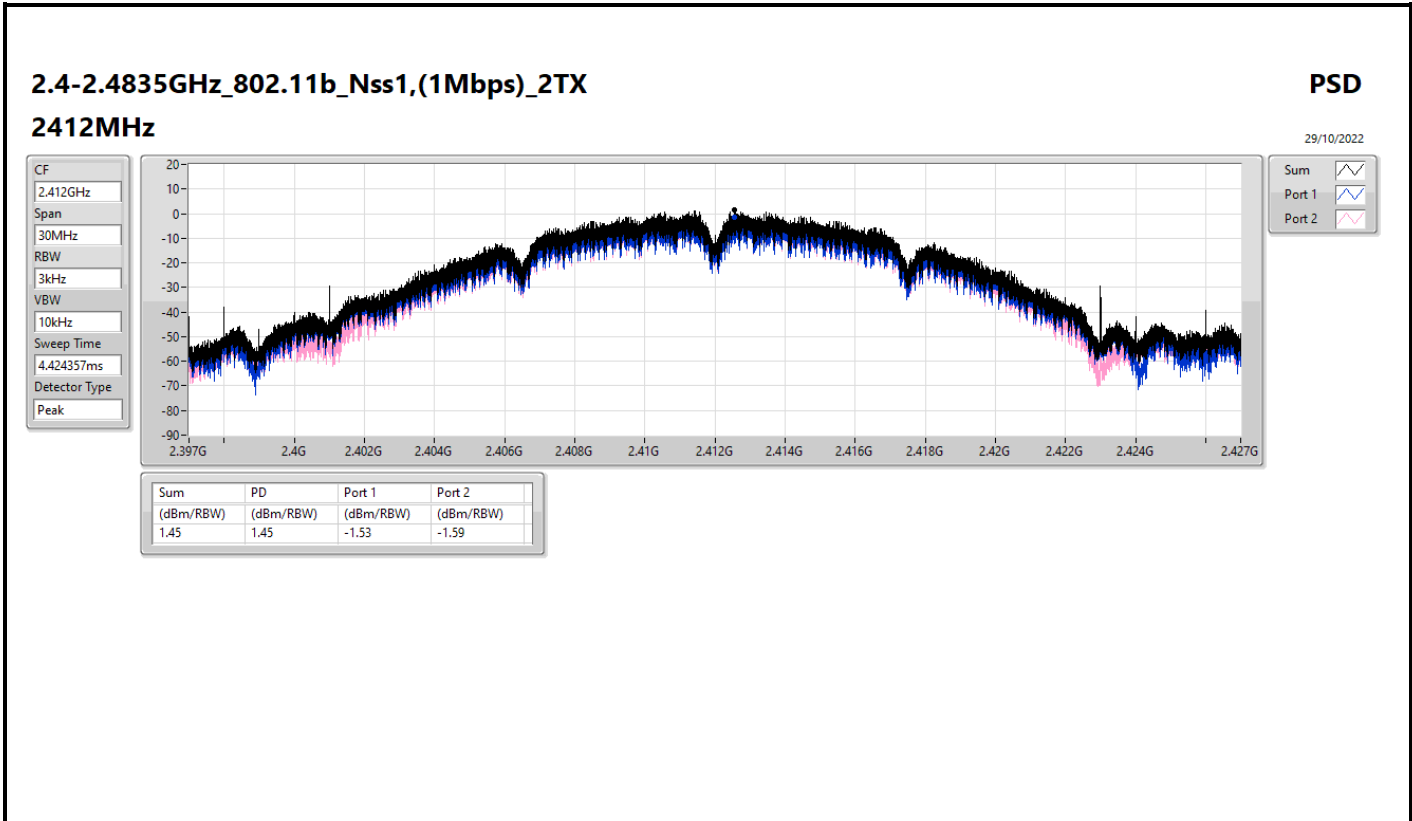

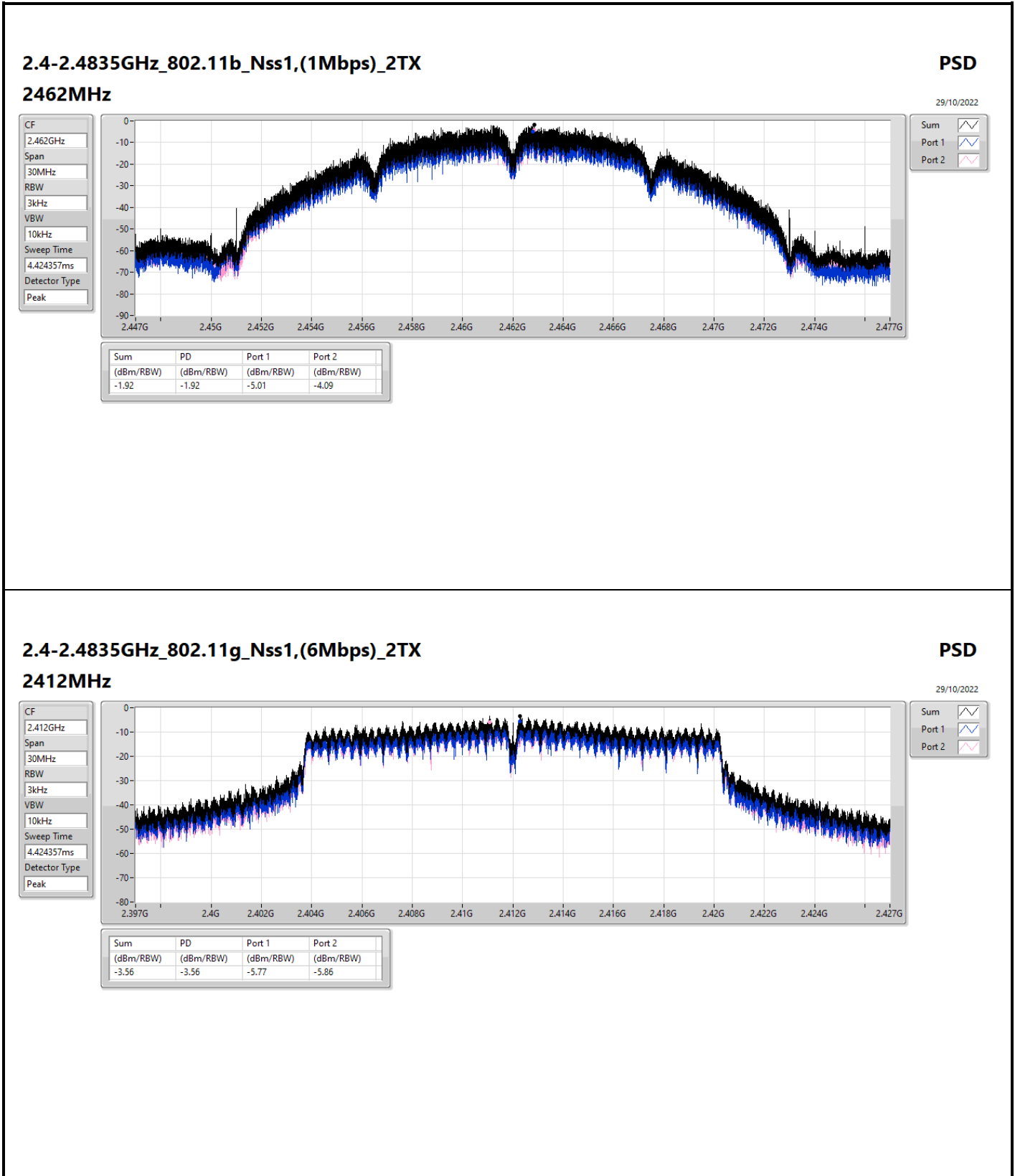

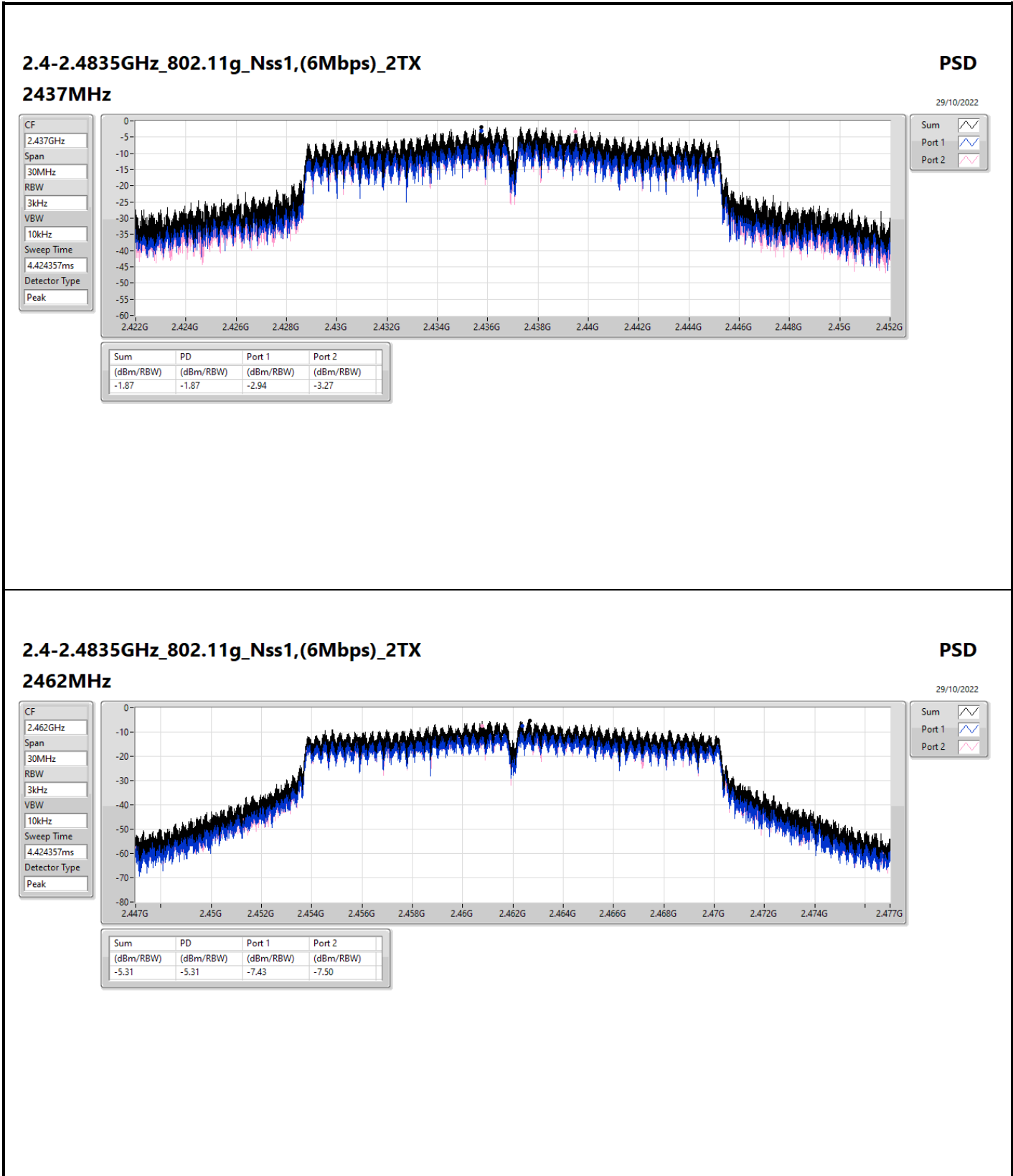

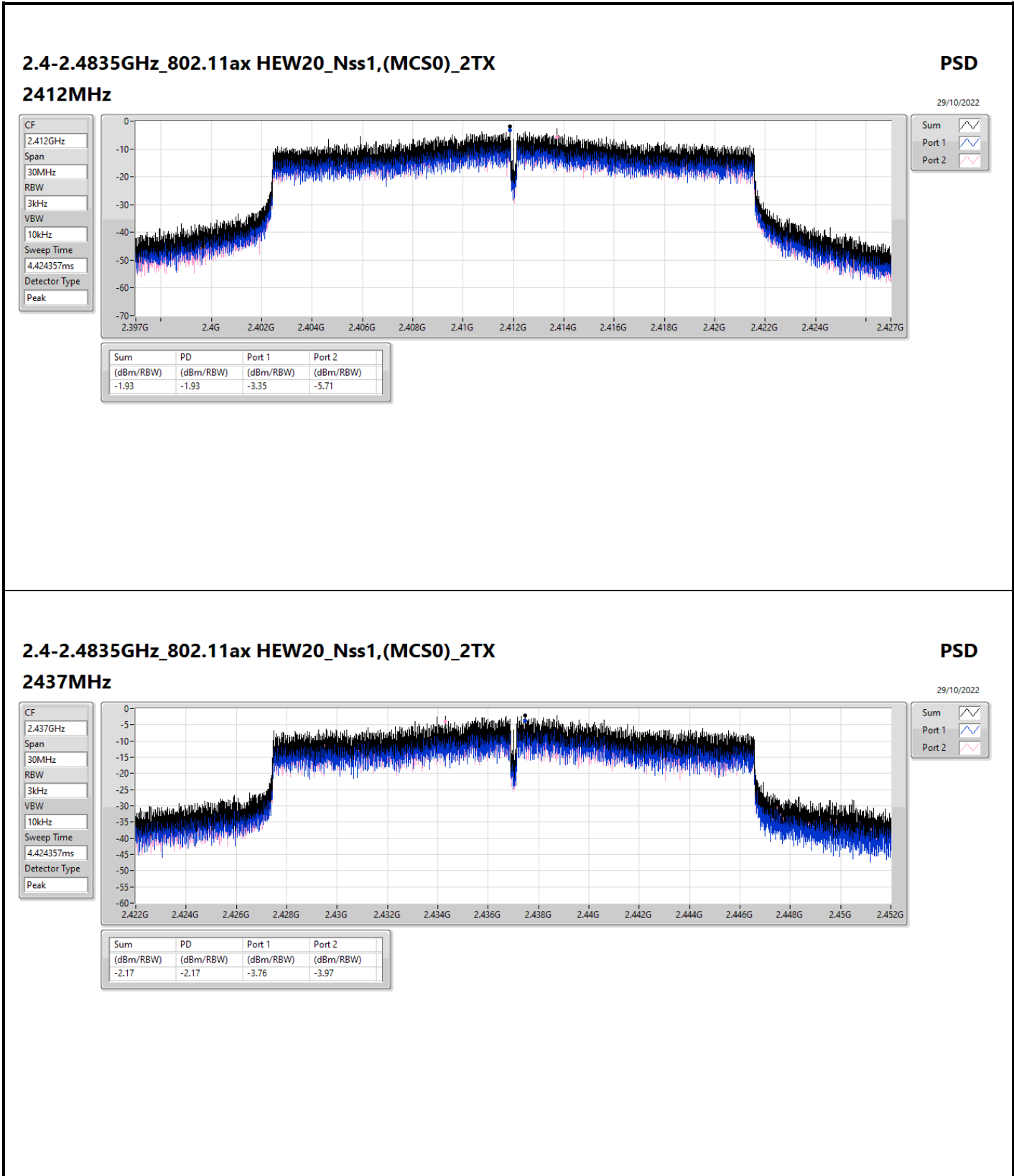

2.4-2.4835GHz_802.11ax HEW20_Nss1,(MCS0)_2TX

2437MHz

PSD

29/10/2022

CF	2.437GHz
Span	30MHz
RBW	3kHz
VBW	10kHz
Sweep Time	4.424357ms
Detector Type	Peak

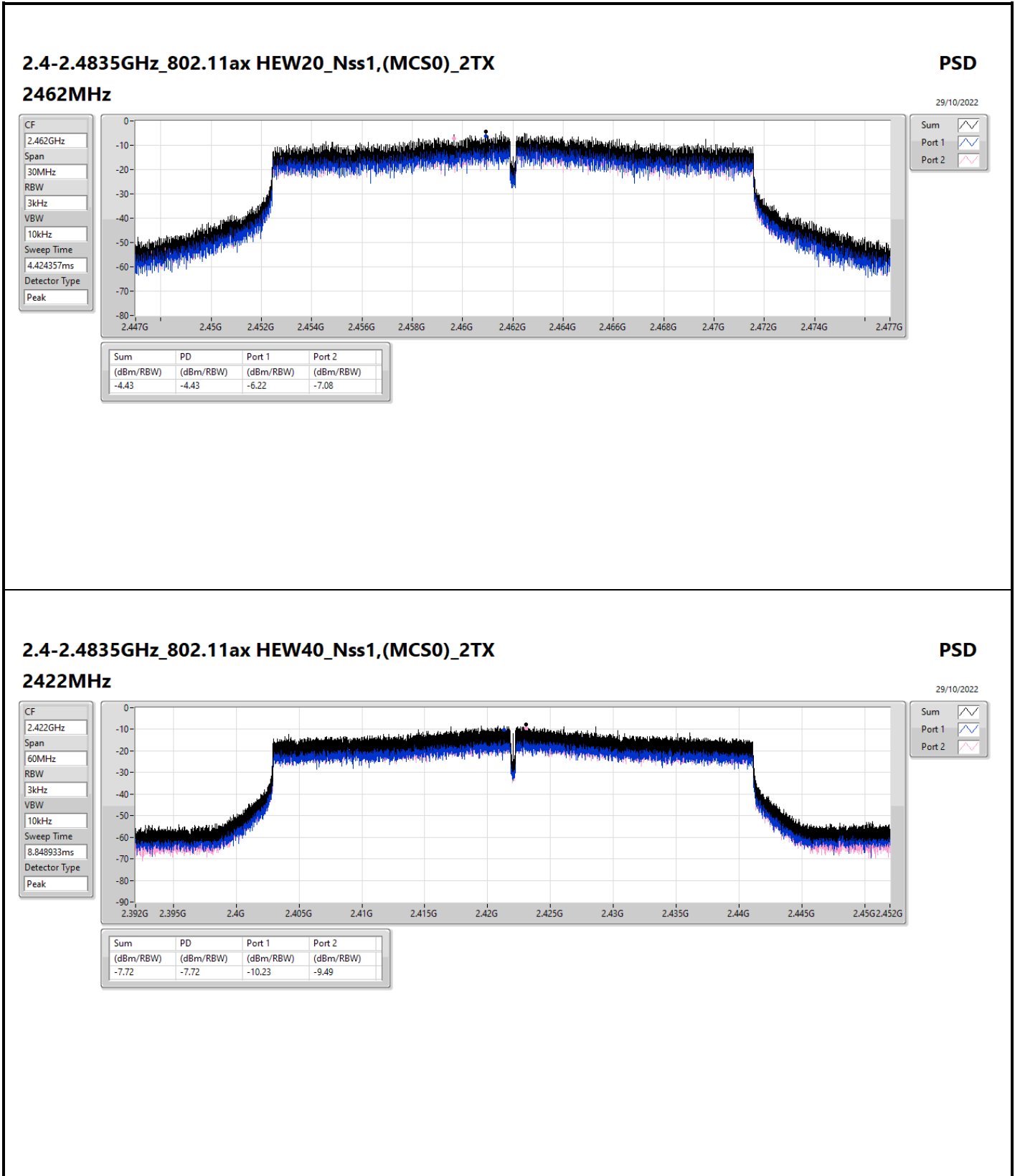

2.4-2.4835GHz_802.11ax HEW40_Nss1,(MCS0)_2TX

2422MHz

PSD

29/10/2022

CF	Span	RBW	VBW	Sweep Time	Detector Type
2.422GHz	60MHz	3kHz	10kHz	8.848933ms	Peak

2.4-2.4835GHz_802.11ax HEW40_Nss1,(MCS0)_2TX

2437MHz

PSD

29/10/2022

CF
2.437GHz

Span
60MHz

RBW
3kHz

VBW
10kHz

Sweep Time
8.848933ms

Detector Type
Peak

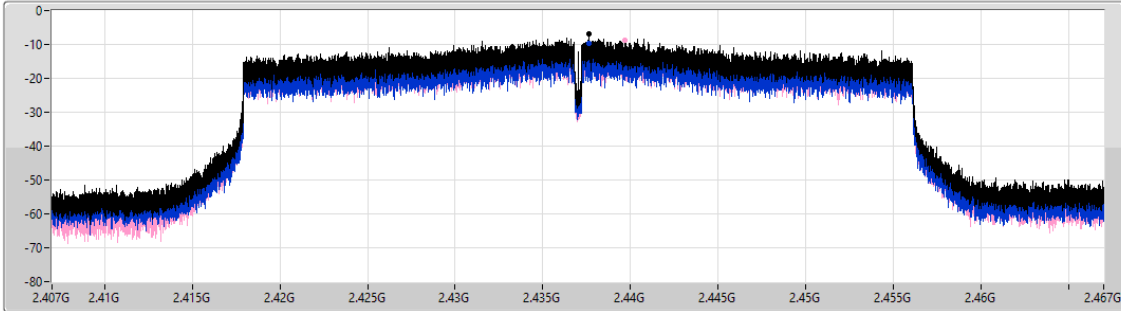

Sum 

Port 1 

Port 2 

Sum	PD	Port 1	Port 2
(dBm/RBW)	(dBm/RBW)	(dBm/RBW)	(dBm/RBW)
-6.96	-6.96	-9.75	-8.77

2.4-2.4835GHz_802.11ax HEW40_Nss1,(MCS0)_2TX

2452MHz

PSD

29/10/2022

CF
2.452GHz

Span
60MHz

RBW
3kHz

VBW
10kHz

Sweep Time
8.848933ms

Detector Type
Peak

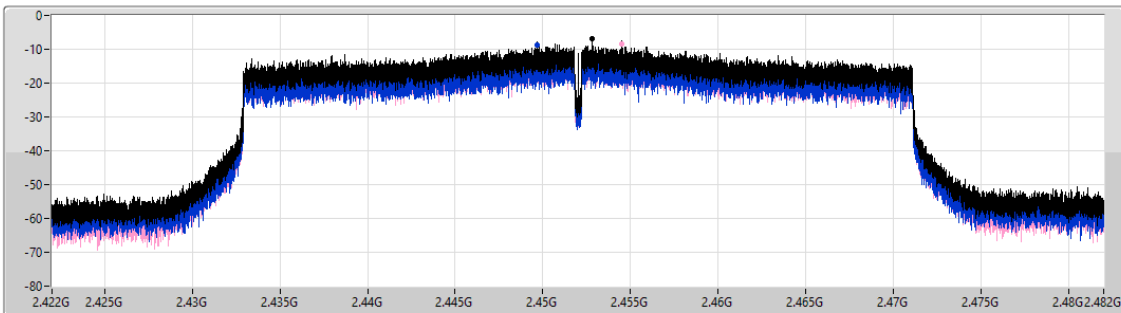

Sum 

Port 1 

Port 2 

Sum	PD	Port 1	Port 2
(dBm/RBW)	(dBm/RBW)	(dBm/RBW)	(dBm/RBW)
-6.81	-6.81	-8.83	-8.30



Summary

Mode	Result	Ref (Hz)	Ref (dBm)	Limit (dBm)	Freq (Hz)	Level (dBm)	Freq (Hz)	Level (dBm)	Freq (Hz)	Level (dBm)	Freq (Hz)	Level (dBm)	Freq (Hz)	Level (dBm)	Port
2.4-2.4835GHz	-	-	-	-	-	-	-	-	-	-	-	-	-	-	-
802.11b_Nss1,(1Mbps)_2TX	Pass	2.43741G	14.87	-15.13	931.71M	-52.66	2.4G	-26.88	2.4G	-26.57	2.50598G	-44.69	14.92772G	-47.96	1
802.11g_Nss1,(6Mbps)_2TX	Pass	2.43824G	13.24	-16.76	882.78M	-51.89	2.39984G	-23.10	2.4G	-23.27	2.50862G	-47.67	17.63895G	-47.48	1
802.11ax HEW20_Nss1,(MCS0)_2TX	Pass	2.43824G	12.07	-17.93	2.1969G	-51.33	2.39992G	-22.06	2.4G	-23.35	2.50686G	-48.38	16.61627G	-47.63	1
802.11ax HEW40_Nss1,(MCS0)_2TX	Pass	2.4344G	5.38	-24.62	2.13108G	-52.94	2.39984G	-36.70	2.4G	-35.36	2.52302G	-49.76	6.94984G	-47.86	1



Result

Mode	Result	Ref (Hz)	Ref (dBm)	Limit (dBm)	Freq (Hz)	Level (dBm)	Freq (Hz)	Level (dBm)	Freq (Hz)	Level (dBm)	Freq (Hz)	Level (dBm)	Freq (Hz)	Level (dBm)	Port
802.11b_Nss1,(1Mbps)_2TX	-	-	-	-	-	-	-	-	-	-	-	-	-	-	-
2412MHz	Pass	2.43741G	14.87	-15.13	931.71M	-52.66	2.4G	-26.88	2.4G	-26.57	2.50598G	-44.69	14.92772G	-47.96	1
2412MHz	Pass	2.43741G	14.87	-15.13	924.72M	-53.32	2.4G	-31.30	2.4G	-30.41	2.5075G	-45.28	17.67266G	-46.54	2
2437MHz	Pass	2.43741G	14.87	-15.13	2.05011G	-53.02	2.39656G	-41.60	2.4G	-50.46	2.50926G	-48.37	2.53193G	-47.14	1
2437MHz	Pass	2.43741G	14.87	-15.13	2.19108G	-53.04	2.39928G	-42.79	2.4G	-47.39	2.50806G	-47.88	2.53193G	-46.01	2
2462MHz	Pass	2.43741G	14.87	-15.13	2.30408G	-51.58	2.3988G	-51.45	2.4G	-51.66	2.50142G	-48.20	6.70413G	-47.74	1
2462MHz	Pass	2.43741G	14.87	-15.13	2.30874G	-50.44	2.4G	-48.49	2.4G	-49.48	2.5035G	-46.92	17.68109G	-46.63	2
802.11g_Nss1,(6Mbps)_2TX	-	-	-	-	-	-	-	-	-	-	-	-	-	-	-
2412MHz	Pass	2.43824G	13.24	-16.76	882.78M	-51.89	2.39984G	-23.10	2.4G	-23.27	2.50862G	-47.67	17.63895G	-47.48	1
2412MHz	Pass	2.43824G	13.24	-16.76	2.30991G	-52.82	2.39992G	-25.40	2.4G	-25.21	2.50614G	-48.15	15.30139G	-48.05	2
2437MHz	Pass	2.43824G	13.24	-16.76	2.13516G	-52.39	2.39984G	-30.54	2.4G	-31.24	2.50198G	-43.28	24.76119G	-46.60	1
2437MHz	Pass	2.43824G	13.24	-16.76	2.18991G	-52.36	2.39952G	-35.90	2.4G	-36.43	2.50134G	-47.12	15.3323G	-47.27	2
2462MHz	Pass	2.43824G	13.24	-16.76	2.1736G	-52.77	2.39104G	-51.62	2.4G	-52.67	2.51654G	-49.70	15.23677G	-46.93	1
2462MHz	Pass	2.43824G	13.24	-16.76	2.18292G	-52.90	2.39704G	-51.24	2.4G	-51.05	2.50598G	-49.74	17.66704G	-47.66	2
802.11ax HEW20_Nss1,(MCS0)_2TX	-	-	-	-	-	-	-	-	-	-	-	-	-	-	-
2412MHz	Pass	2.43824G	12.07	-17.93	2.1969G	-51.33	2.39992G	-22.06	2.4G	-23.35	2.50686G	-48.38	16.61627G	-47.63	1
2412MHz	Pass	2.43824G	12.07	-17.93	2.30874G	-52.79	2.4G	-24.26	2.4G	-24.25	2.5071G	-48.88	5.83597G	-47.59	2
2437MHz	Pass	2.43824G	12.07	-17.93	2.16661G	-52.11	2.39952G	-33.67	2.4G	-36.69	2.50254G	-44.82	16.77922G	-47.60	1
2437MHz	Pass	2.43824G	12.07	-17.93	2.30408G	-51.83	2.39904G	-34.49	2.4G	-36.51	2.50446G	-41.60	23.48003G	-47.51	2
2462MHz	Pass	2.43824G	12.07	-17.93	2.18991G	-52.91	2.39064G	-51.03	2.4G	-51.74	2.50558G	-50.19	16.63312G	-47.47	1
2462MHz	Pass	2.43824G	12.07	-17.93	952.68M	-53.43	2.39656G	-51.15	2.4G	-52.53	2.50078G	-48.58	17.65861G	-47.98	2
802.11ax HEW40_Nss1,(MCS0)_2TX	-	-	-	-	-	-	-	-	-	-	-	-	-	-	-
2422MHz	Pass	2.4344G	5.38	-24.62	2.13108G	-52.94	2.39984G	-36.70	2.4G	-35.36	2.52302G	-49.76	6.94984G	-47.86	1
2422MHz	Pass	2.4344G	5.38	-24.62	2.30397G	-51.83	2.39984G	-36.97	2.4G	-35.83	2.5035G	-49.58	17.6857G	-46.56	2
2437MHz	Pass	2.4344G	5.38	-24.62	2.14596G	-52.58	2.39872G	-39.09	2.4G	-40.91	2.50222G	-47.86	17.68009G	-47.45	1
2437MHz	Pass	2.4344G	5.38	-24.62	2.08871G	-52.32	2.39872G	-42.28	2.4G	-43.23	2.50062G	-47.86	5.77753G	-48.02	2
2452MHz	Pass	2.4344G	5.38	-24.62	2.16428G	-51.25	2.39936G	-48.09	2.4G	-48.38	2.50446G	-43.57	16.22452G	-47.24	1
2452MHz	Pass	2.4344G	5.38	-24.62	1.73949G	-52.48	2.39424G	-46.81	2.4G	-48.86	2.50286G	-42.67	15.34389G	-47.49	2

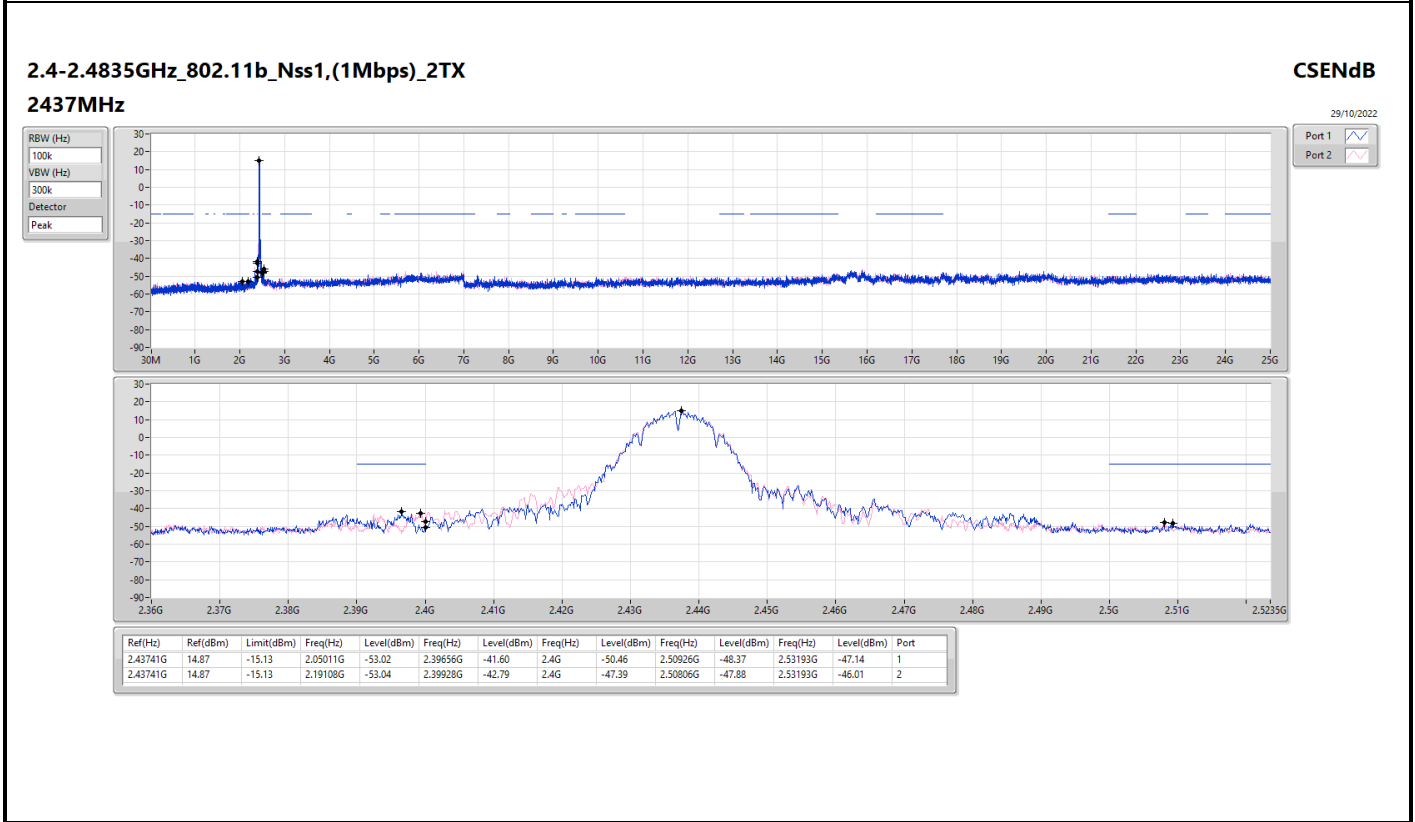
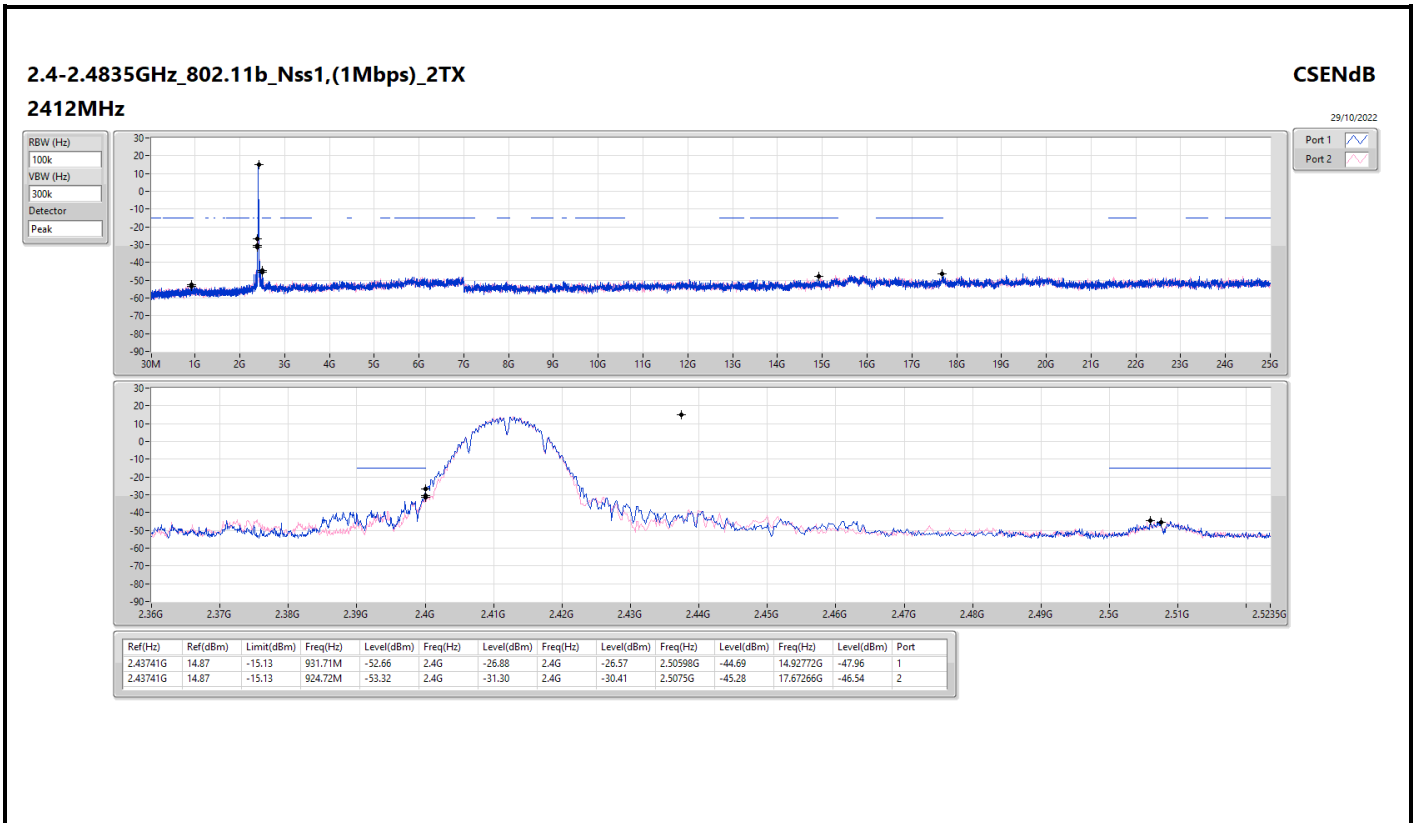

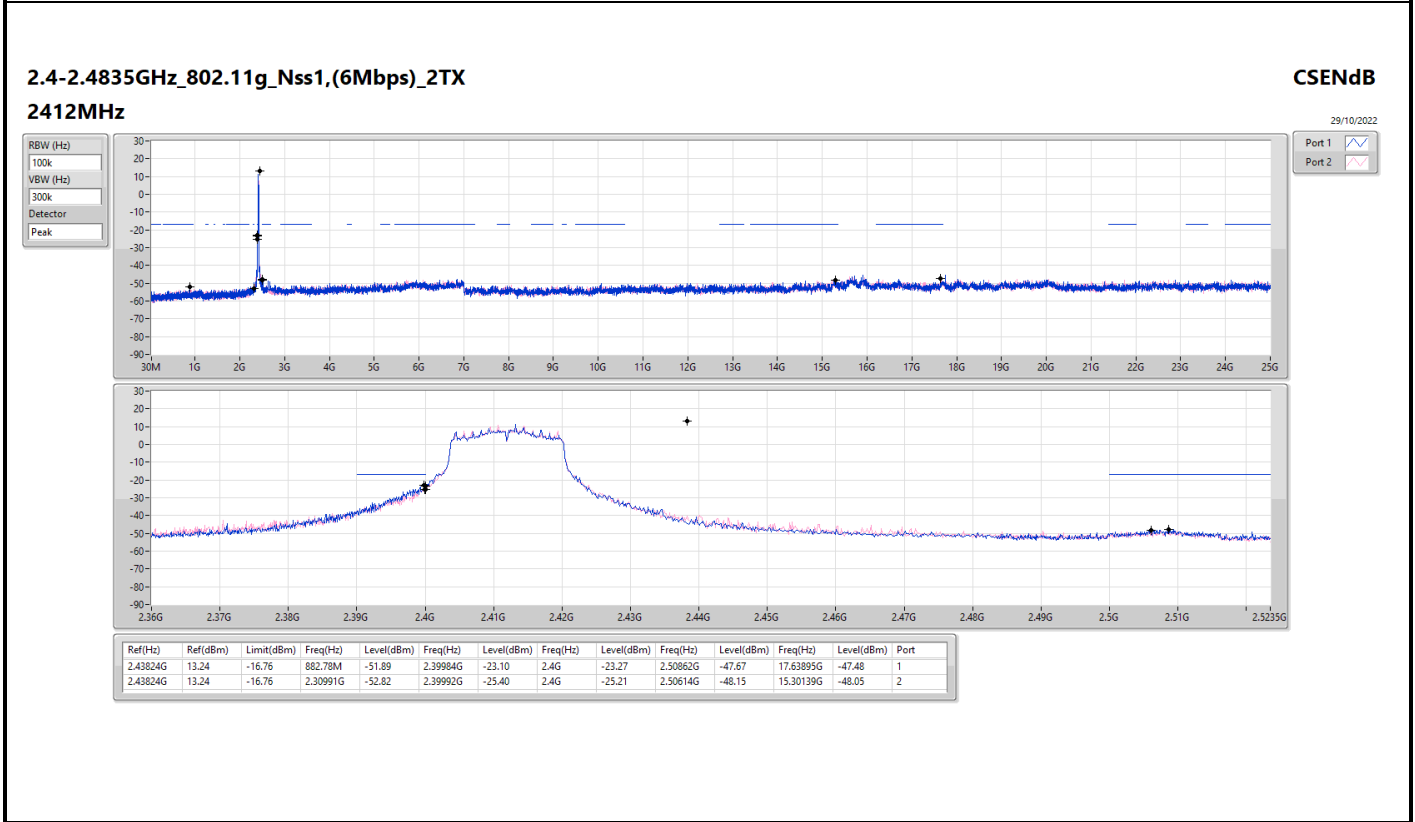
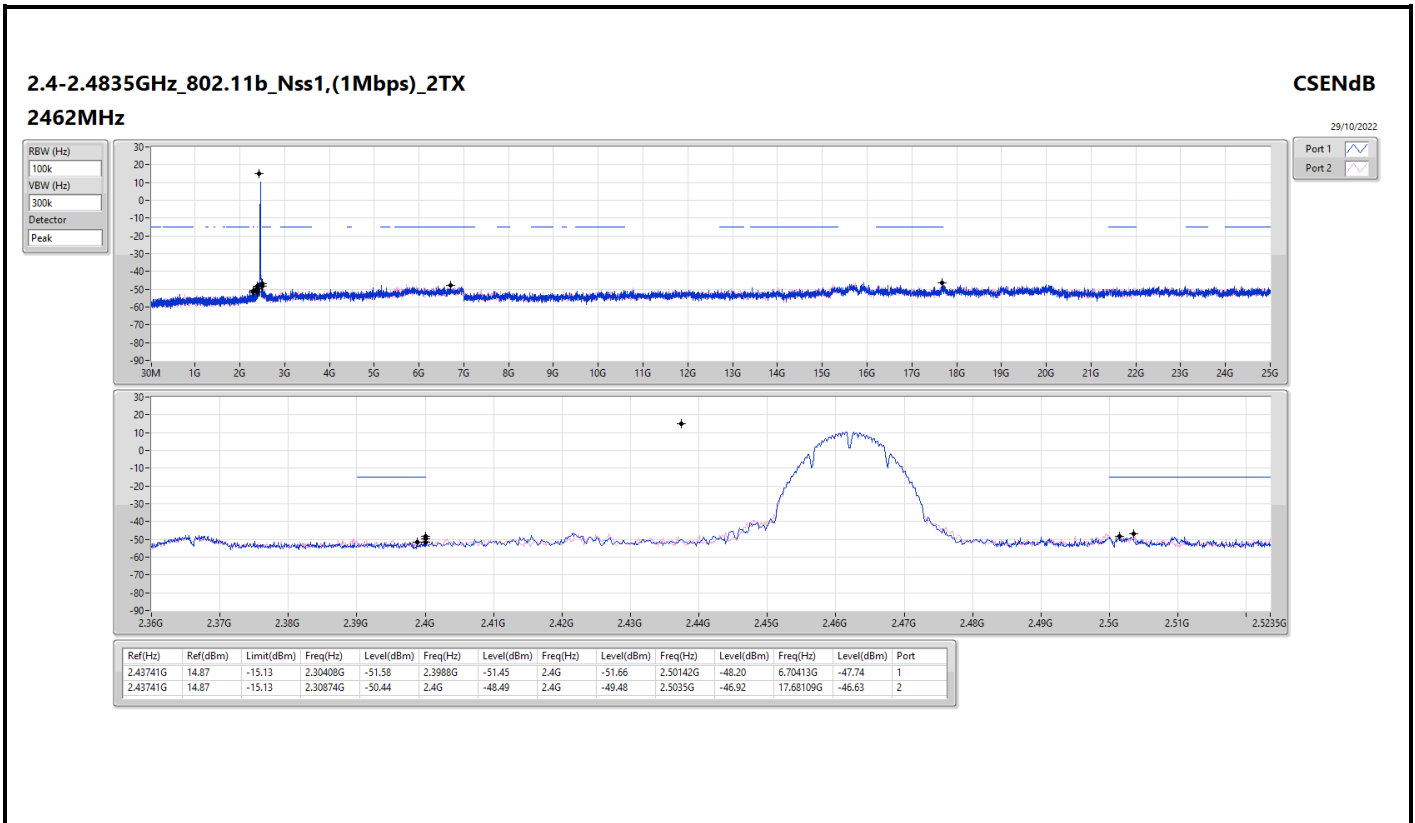

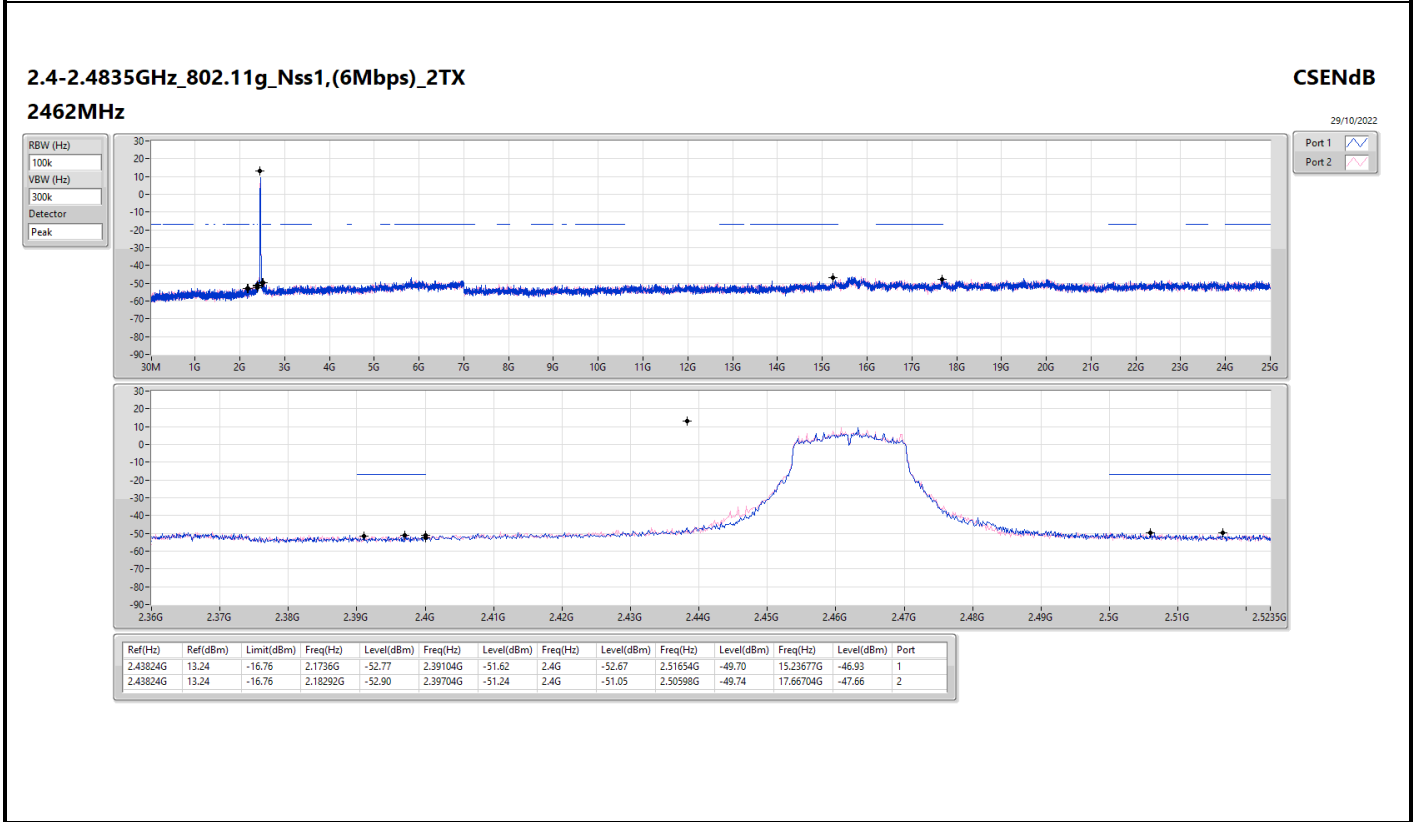
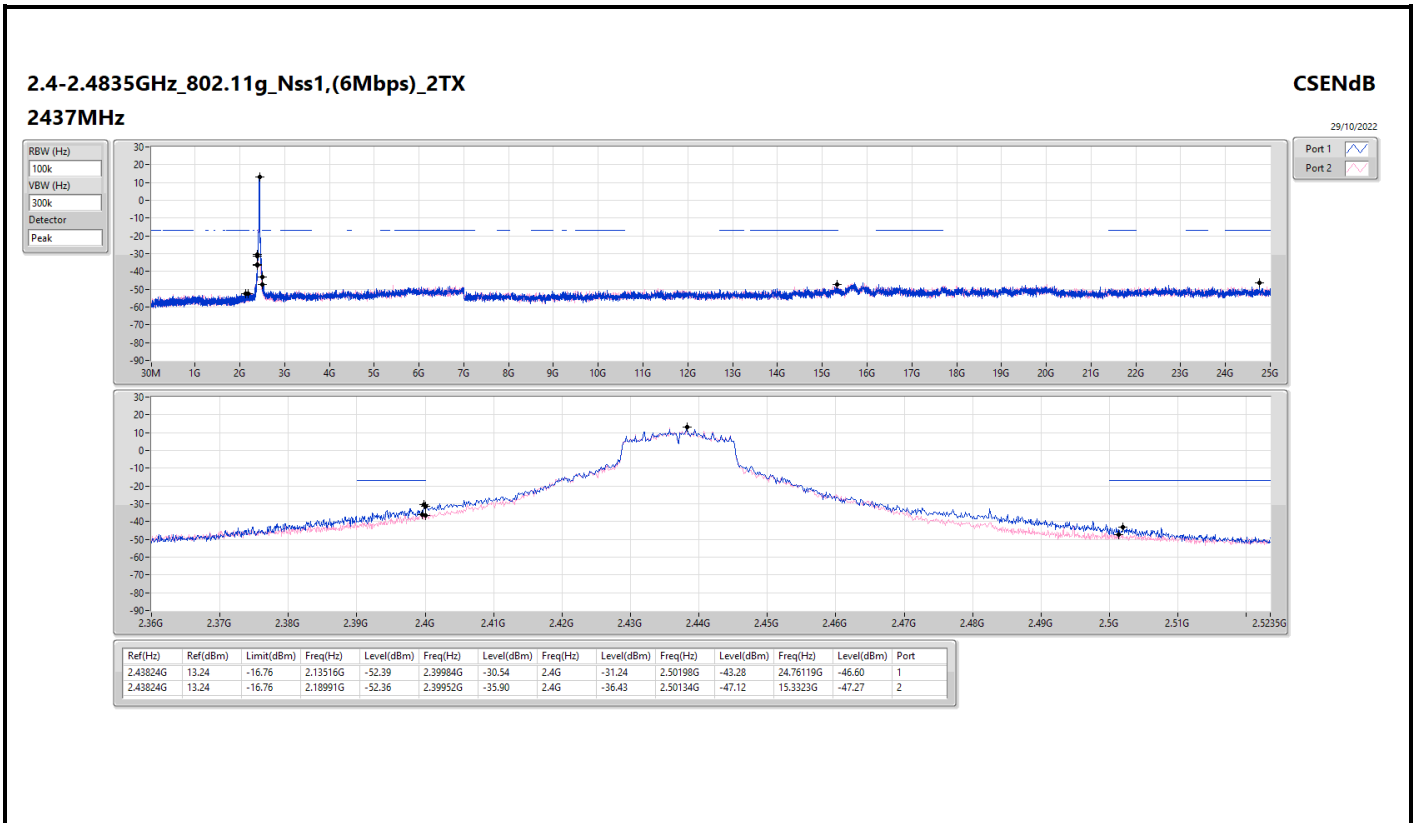

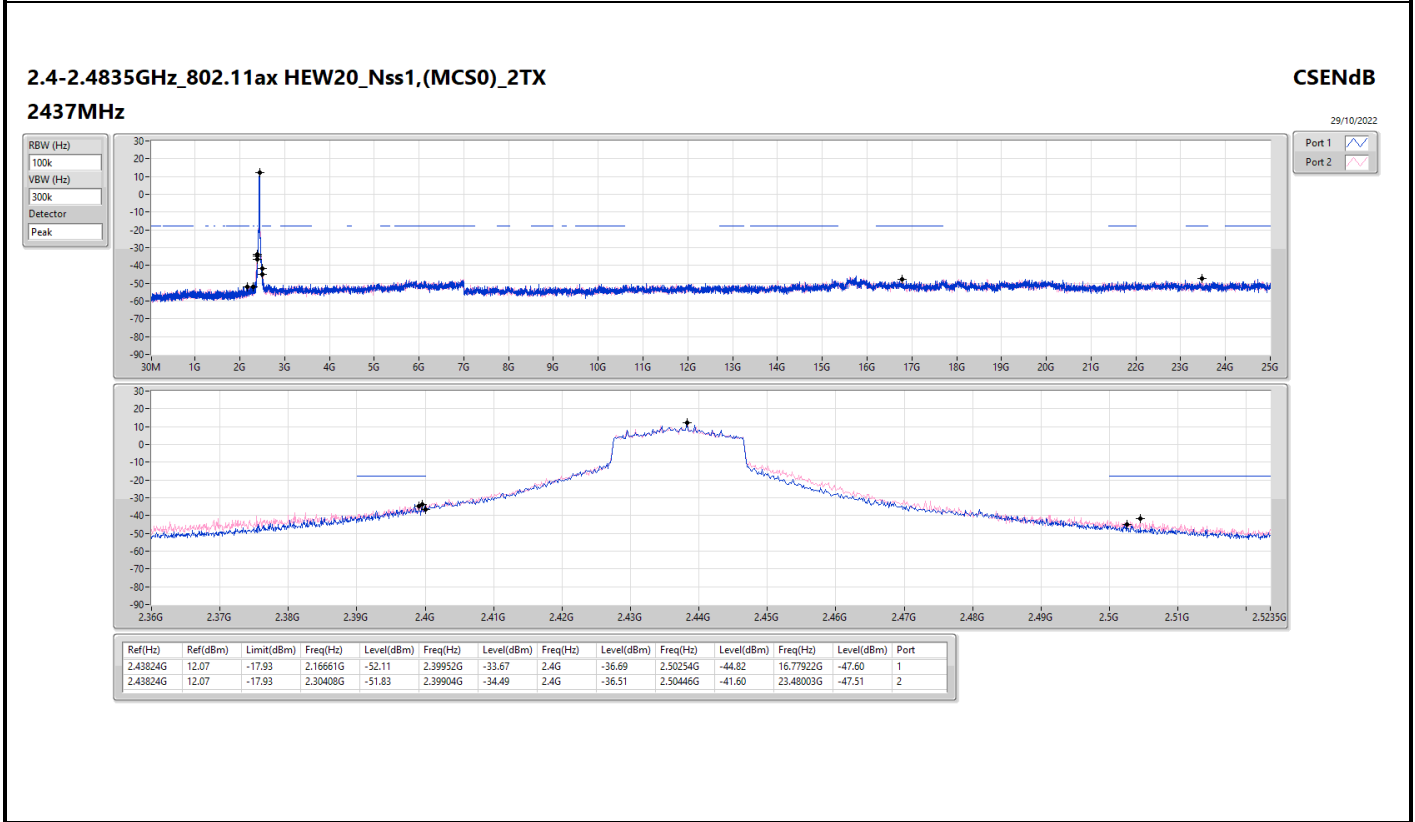
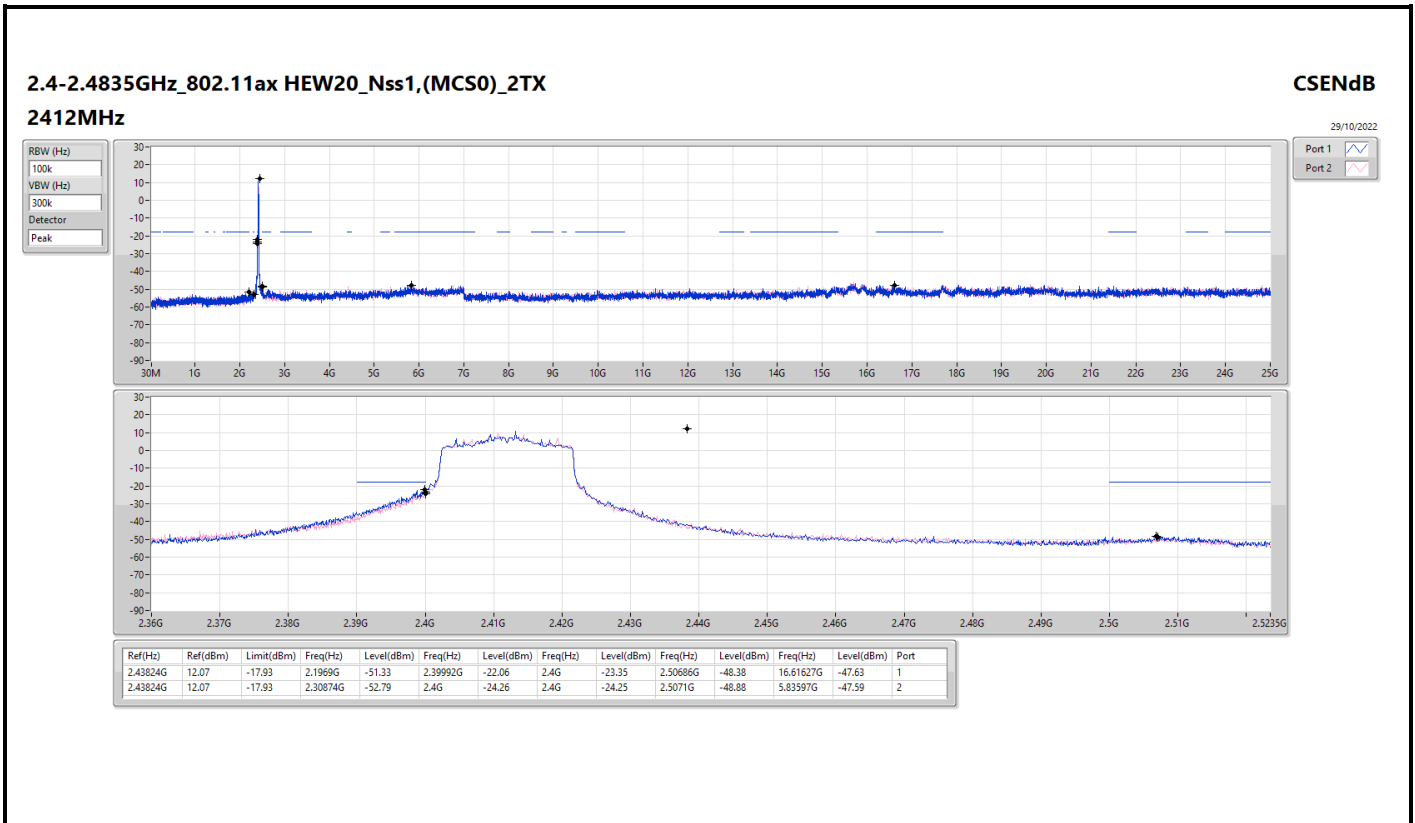

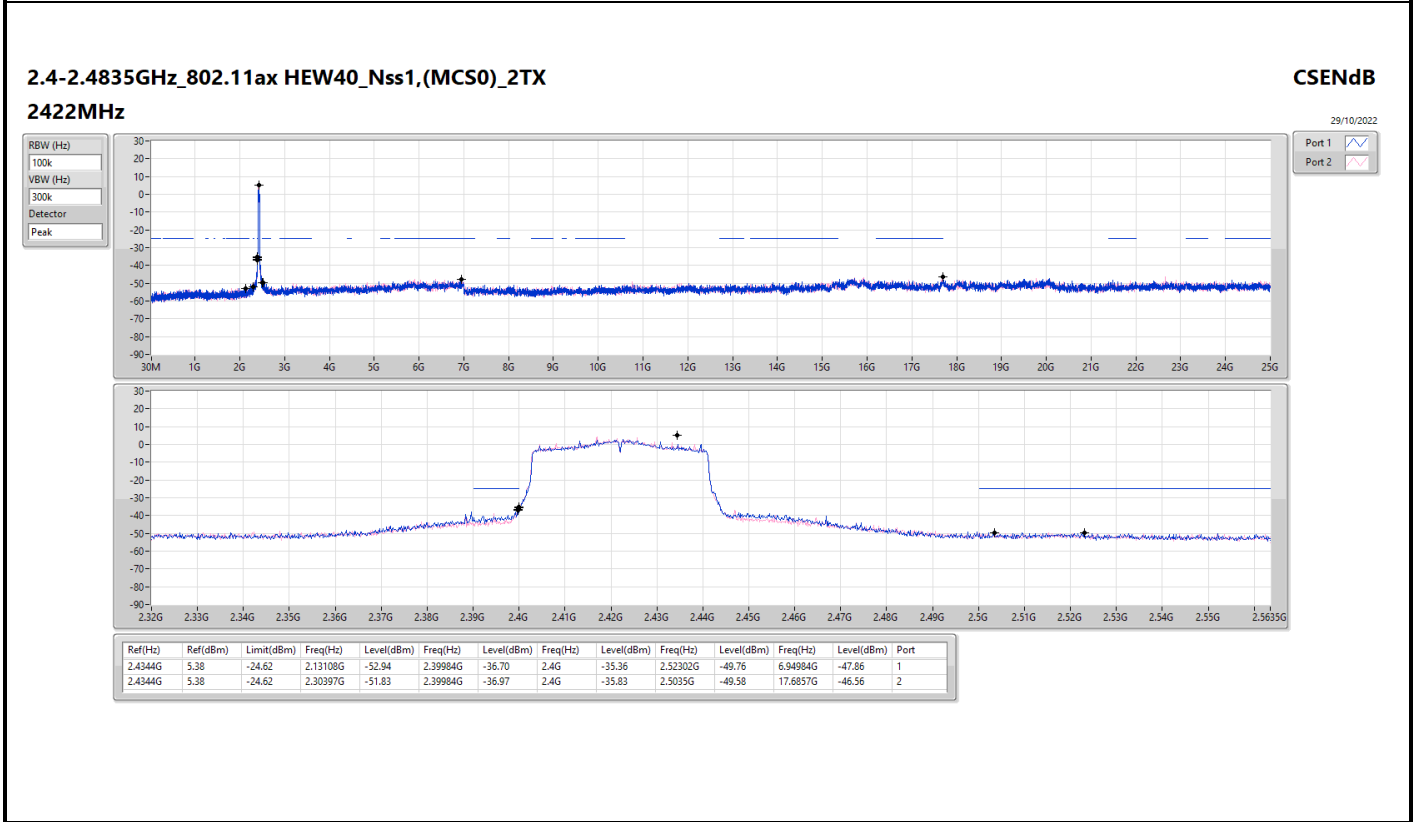
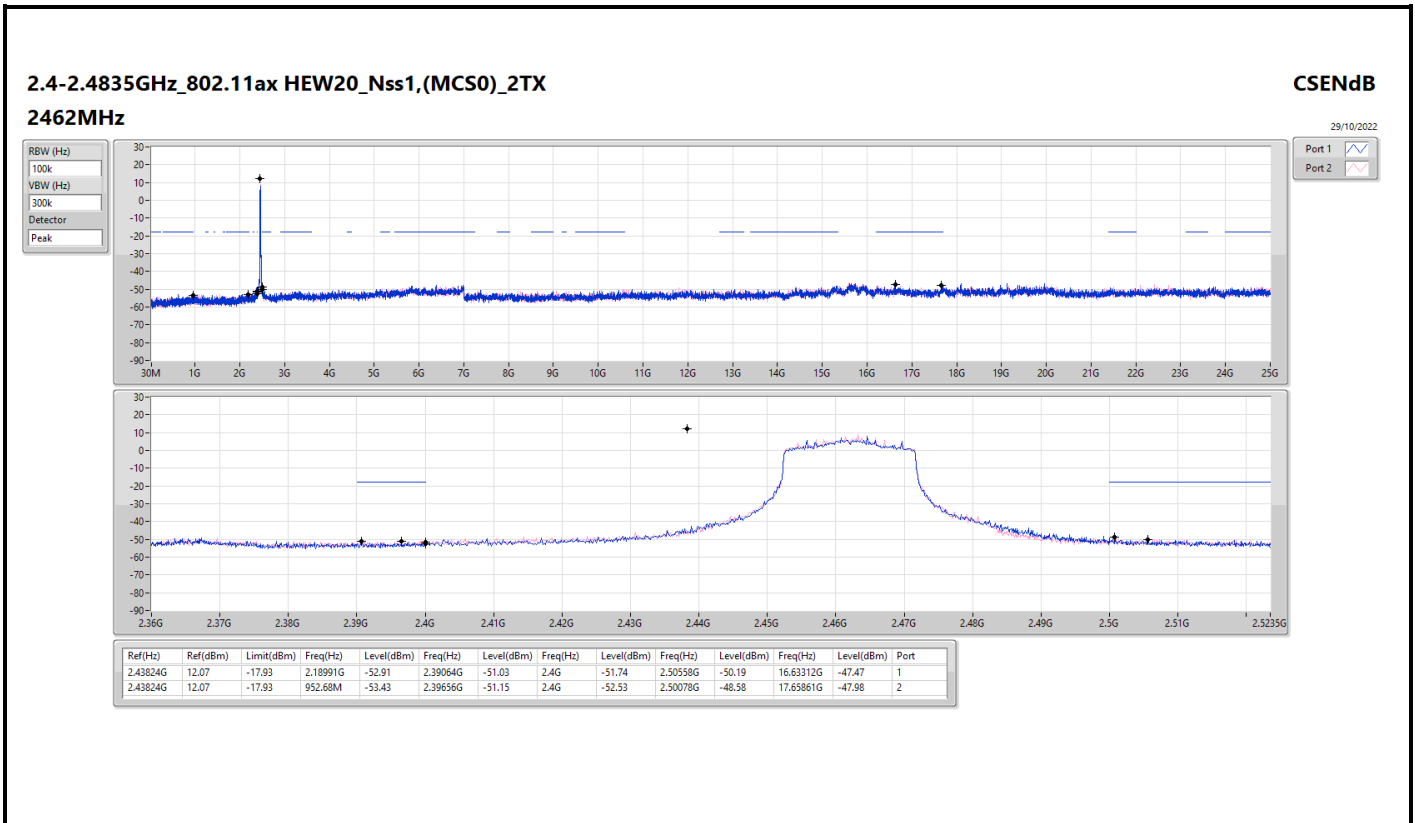

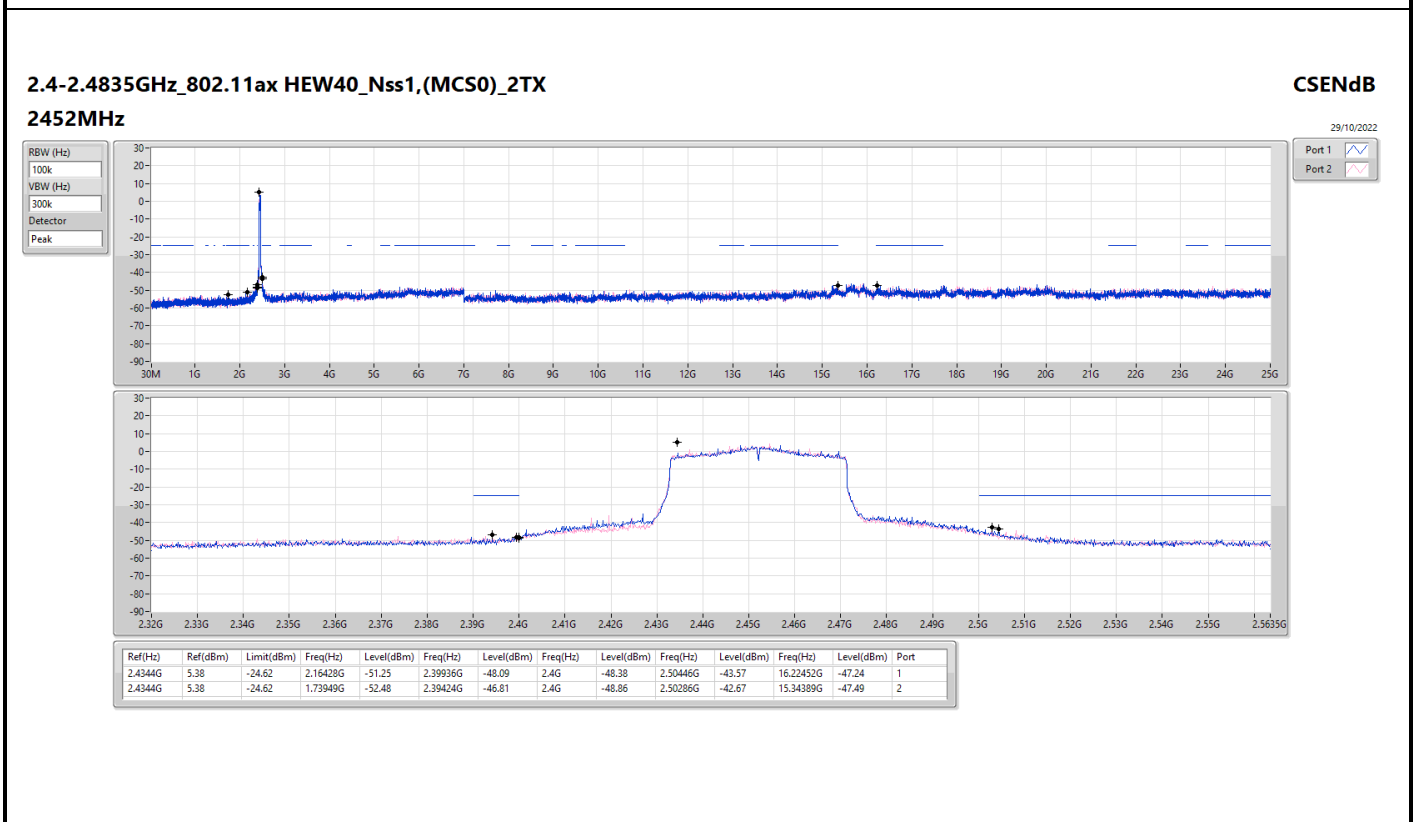
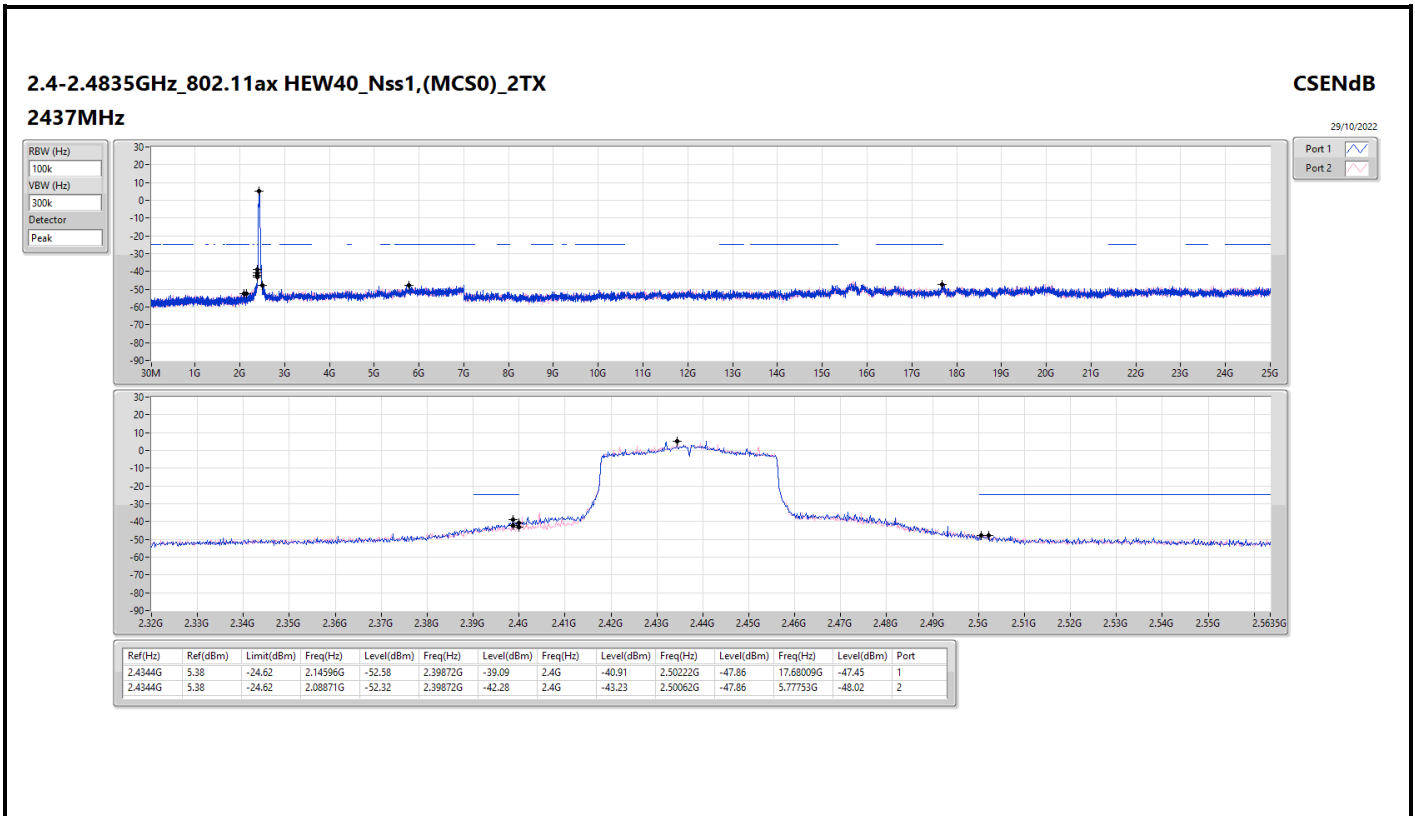



Summary

Mode	Result	Type	Freq (Hz)	Level (dBuV/m)	Limit (dBuV/m)	Margin (dB)	Condition
Mode 3	Pass	QP	44.55M	36.91	40.00	-3.09	Vertical

Mode 3

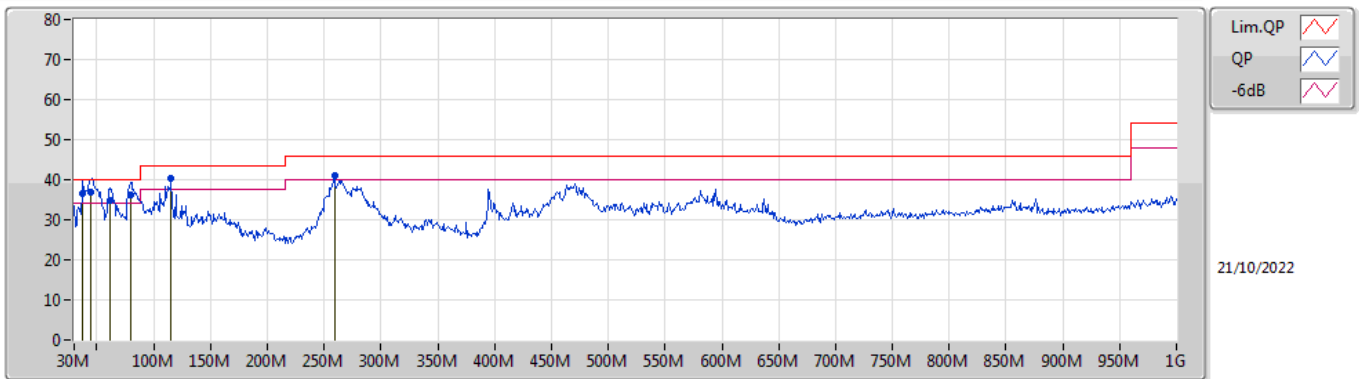

Type	Freq (Hz)	Level (dBuV/m)	Limit (dBuV/m)	Margin (dB)	Factor (dB/m)	Dist (m)	Condition	Azimuth (°)	Height (m)	Comment	Raw (dBuV/m)	AF (dB/m)	CL (dB)	PA (dB)
QP	37.76M	36.69	40.00	-3.31	-10.89	3	Vertical	191	1.00	-	47.58	20.43	1.14	32.46
QP	44.55M	36.91	40.00	-3.09	-14.49	3	Vertical	291	1.00	"Worst"	51.40	16.76	1.23	32.48
QP	61.04M	34.88	40.00	-5.12	-18.52	3	Vertical	0	1.50	-	53.40	12.44	1.50	32.46
QP	79.47M	36.28	40.00	-3.72	-17.81	3	Vertical	0	2.00	-	54.09	12.92	1.66	32.39
PK	115.36M	40.26	43.50	-3.24	-12.47	3	Vertical	224	1.00	-	52.73	17.90	2.02	32.39
PK	258.92M	40.87	46.00	-5.13	-9.65	3	Vertical	125	1.25	-	50.52	19.57	3.09	32.31

Mode 3

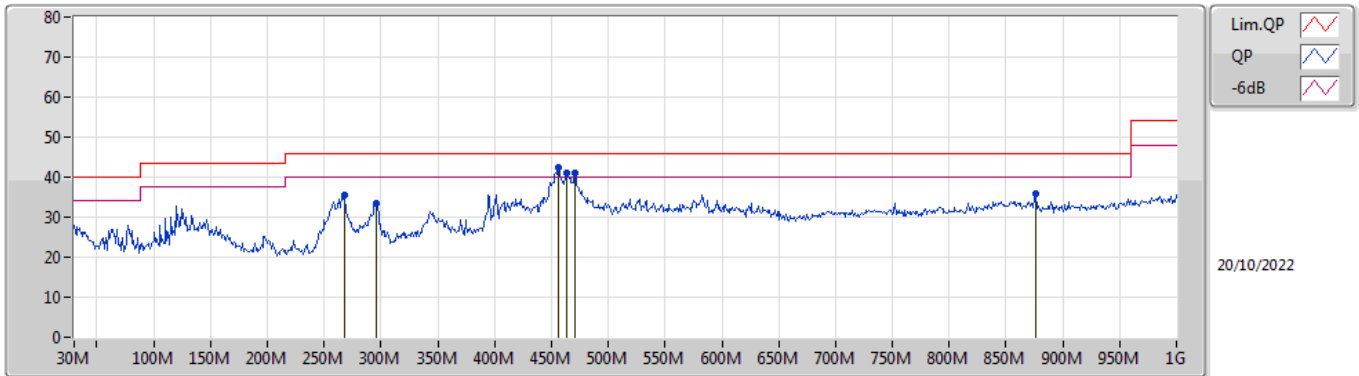

Type	Freq (Hz)	Level (dBuV/m)	Limit (dBuV/m)	Margin (dB)	Factor (dB/m)	Dist (m)	Condition	Azimuth (°)	Height (m)	Comment	Raw (dBuV/m)	AF (dB/m)	CL (dB)	PA (dB)
PK	267.65M	35.49	46.00	-10.51	-9.99	3	Horizontal	186	1.00	-	45.48	19.19	3.14	32.32
PK	295.78M	33.37	46.00	-12.63	-10.05	3	Horizontal	249	1.25	-	43.42	18.99	3.32	32.36
PK	455.83M	42.34	46.00	-3.66	-5.23	3	Horizontal	252	1.00	"Worst"	47.57	22.72	4.20	32.15
PK	463.59M	41.11	46.00	-4.89	-5.03	3	Horizontal	252	1.00	-	46.14	22.90	4.23	32.16
PK	470.38M	40.94	46.00	-5.06	-4.82	3	Horizontal	278	1.00	-	45.76	23.09	4.26	32.17
PK	875.84M	35.73	46.00	-10.27	0.68	3	Horizontal	181	1.00	-	35.05	26.31	5.92	31.55



Summary

Mode	Result	Type	Freq (Hz)	Level (dBuV/m)	Limit (dBuV/m)	Margin (dB)	Dist (m)	Condition	Azimuth (°)	Height (m)	Comments
2.4-2.4835GHz	-	-	-	-	-	-	-	-	-	-	-
802.11ax HEW20_Nss1,(MCS0)_2TX	Pass	AV	2.4835G	53.99	54.00	-0.01	3	Vertical	339	1.80	-

2.4-2.4835GHz_802.11b_Nss1,(1Mbps)_2TX

2412MHz_TX

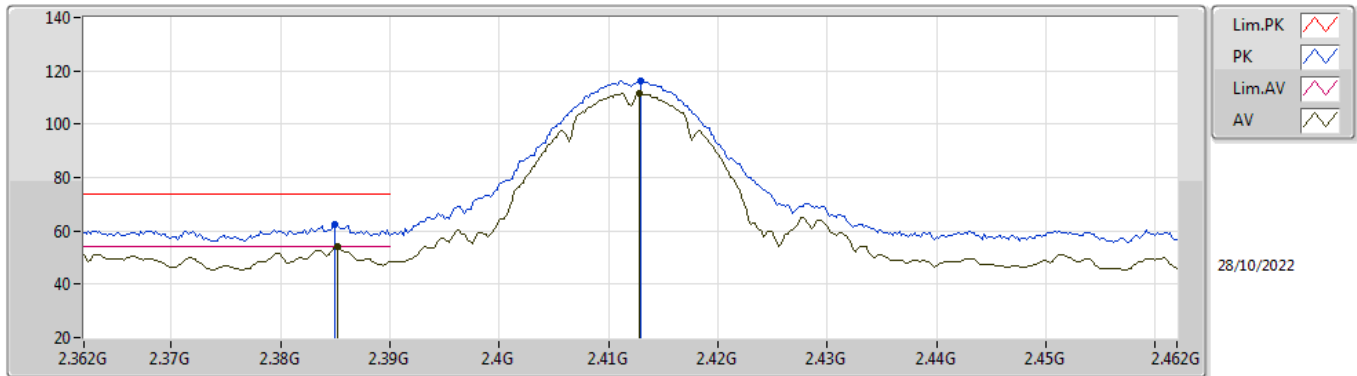

EUT_Y_2TX
Setting 22.5
03-D-J-8

Type	Freq (Hz)	Level (dBuV/m)	Limit (dBuV/m)	Margin (dB)	Raw (dBuV)	Dist (m)	Condition	Azimuth (°)	Height (m)	Comment	AF (dB)	CL (dB)	PA (dB)
PK	2.385G	62.60	74.00	-11.40	30.37	3	Vertical	315	1.72	-	28.24	3.99	-
AV	2.3852G	53.93	54.00	-0.07	21.70	3	Vertical	315	1.72	-	28.24	3.99	-
PK	2.413G	116.31	Inf	-Inf	84.00	3	Vertical	315	1.72	-	28.30	4.01	-
AV	2.4128G	111.43	Inf	-Inf	79.12	3	Vertical	315	1.72	-	28.30	4.01	-

2.4-2.4835GHz_802.11b_Nss1,(1Mbps)_2TX

2412MHz_TX

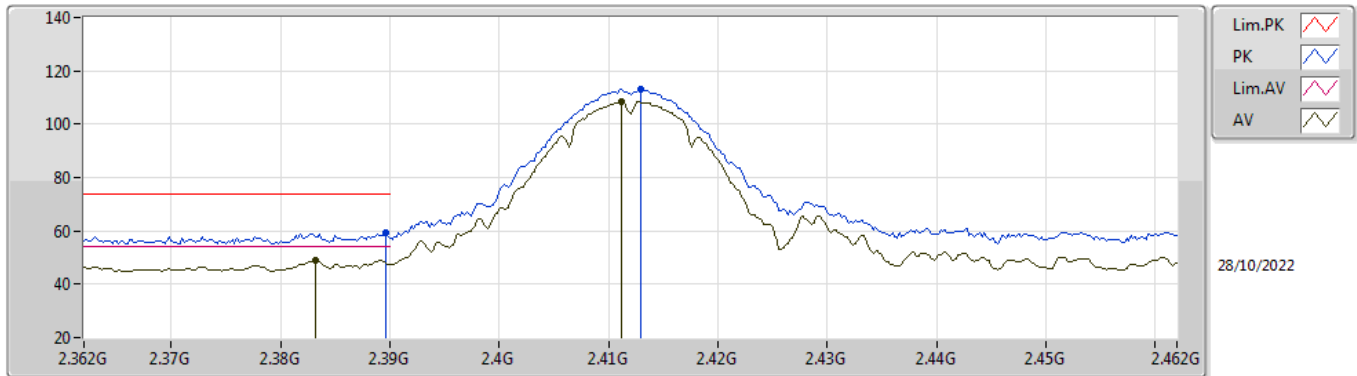

EUT_Y_2TX
 Setting 22.5
 03-D-J-8

Type	Freq (Hz)	Level (dBuV/m)	Limit (dBuV/m)	Margin (dB)	Raw (dBuV)	Dist (m)	Condition	Azimuth (°)	Height (m)	Comment	AF (dB)	CL (dB)	PA (dB)
PK	2.3896G	59.51	74.00	-14.49	27.26	3	Horizontal	305	1.80	-	28.26	3.99	-
AV	2.3832G	49.08	54.00	-4.92	16.87	3	Horizontal	305	1.80	-	28.23	3.98	-
PK	2.413G	113.16	Inf	-Inf	80.85	3	Horizontal	305	1.80	-	28.30	4.01	-
AV	2.4112G	108.43	Inf	-Inf	76.12	3	Horizontal	305	1.80	-	28.30	4.01	-

2.4-2.4835GHz_802.11b_Nss1,(1Mbps)_2TX

2412MHz_TX

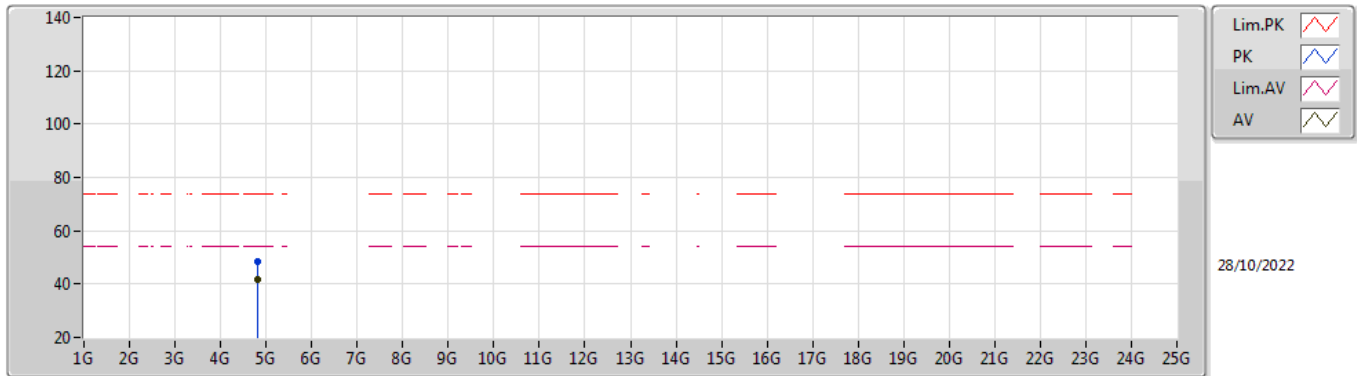

EUT X_2TX
 Setting 22.5
 03-D-J-8

Type	Freq (Hz)	Level (dBuV/m)	Limit (dBuV/m)	Margin (dB)	Raw (dBuV)	Dist (m)	Condition	Azimuth (°)	Height (m)	Comment	AF (dB)	CL (dB)	PA (dB)
PK	4.824G	48.48	74.00	-25.52	43.53	3	Vertical	329	1.80	-	33.34	6.51	34.90
AV	4.824G	41.93	54.00	-12.07	36.98	3	Vertical	329	1.80	-	33.34	6.51	34.90

2.4-2.4835GHz_802.11b_Nss1,(1Mbps)_2TX

2412MHz_TX

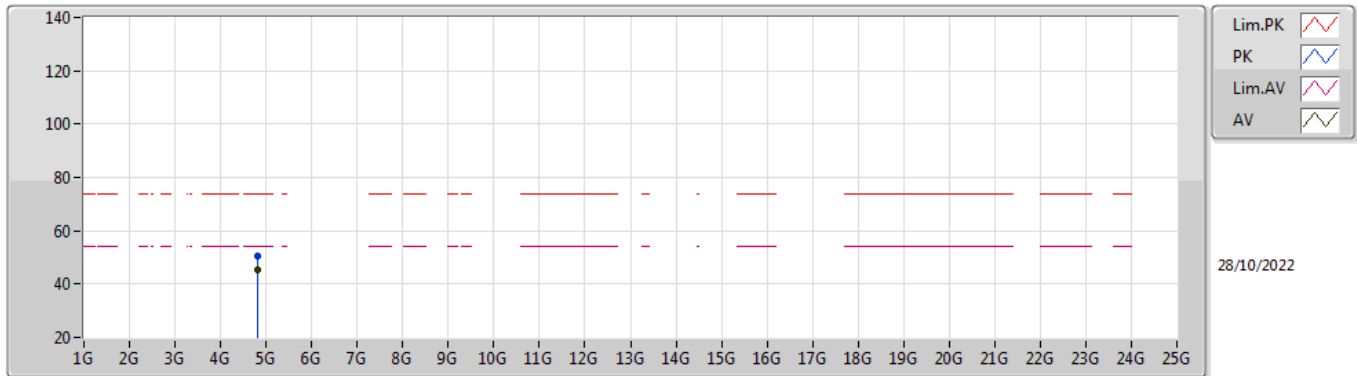

EUT X_2TX
 Setting 22.5
 03-D-J-8

Type	Freq (Hz)	Level (dBuV/m)	Limit (dBuV/m)	Margin (dB)	Raw (dBuV)	Dist (m)	Condition	Azimuth (°)	Height (m)	Comment	AF (dB)	CL (dB)	PA (dB)
PK	4.82406G	50.47	74.00	-23.53	45.52	3	Horizontal	28	2.20	-	33.34	6.51	34.90
AV	4.824G	45.18	54.00	-8.82	40.23	3	Horizontal	28	2.20	-	33.34	6.51	34.90

2.4-2.4835GHz_802.11b_Nss1,(1Mbps)_2TX

2437MHz_TX

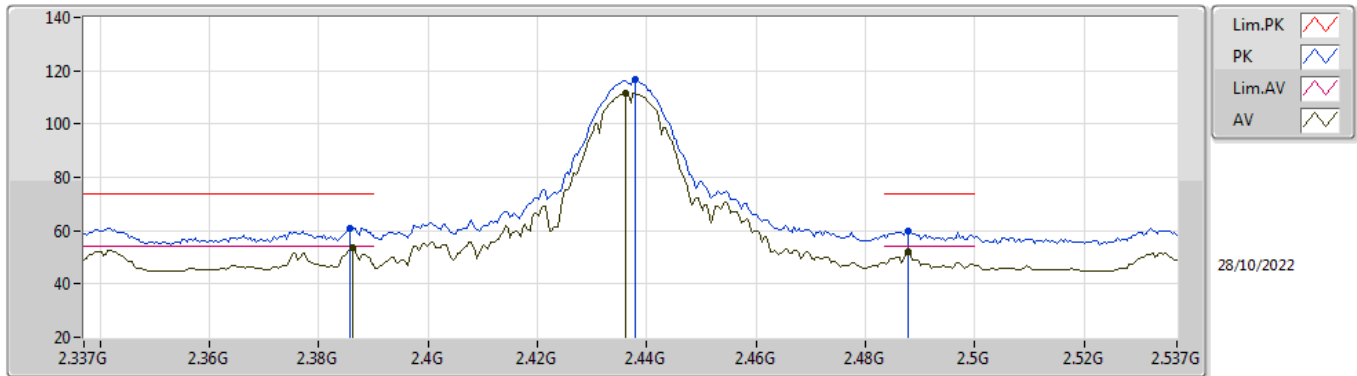

EUT Y_2TX
Setting 23
03-D-J-8

Type	Freq (Hz)	Level (dBuV/m)	Limit (dBuV/m)	Margin (dB)	Raw (dBuV)	Dist (m)	Condition	Azimuth (°)	Height (m)	Comment	AF (dB)	CL (dB)	PA (dB)
PK	2.3858G	61.09	74.00	-12.91	28.86	3	Vertical	306	1.11	-	28.24	3.99	-
AV	2.3862G	53.57	54.00	-0.43	21.34	3	Vertical	306	1.11	-	28.24	3.99	-
PK	2.4378G	116.47	Inf	-Inf	84.13	3	Vertical	306	1.11	-	28.30	4.04	-
AV	2.4362G	111.77	Inf	-Inf	79.43	3	Vertical	306	1.11	-	28.30	4.04	-
PK	2.4878G	59.98	74.00	-14.02	27.44	3	Vertical	306	1.11	-	28.45	4.09	-
AV	2.4878G	51.90	54.00	-2.10	19.36	3	Vertical	306	1.11	-	28.45	4.09	-

2.4-2.4835GHz_802.11b_Nss1,(1Mbps)_2TX

2437MHz_TX

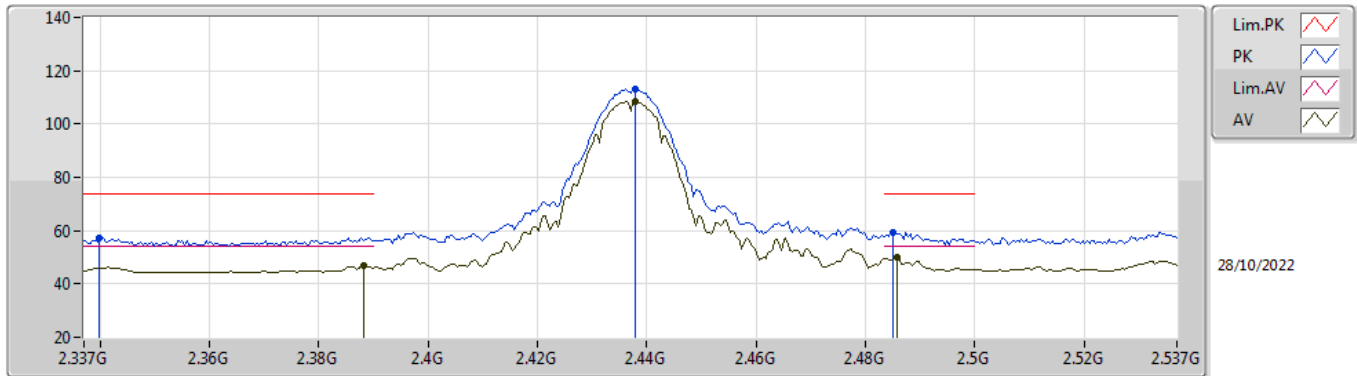

EUT Y_2TX
 Setting 23
 03-D-J-8

Type	Freq (Hz)	Level (dBuV/m)	Limit (dBuV/m)	Margin (dB)	Raw (dBuV)	Dist (m)	Condition	Azimuth (°)	Height (m)	Comment	AF (dB)	CL (dB)	PA (dB)
PK	2.3398G	57.33	74.00	-16.67	25.33	3	Horizontal	306	1.56	-	28.06	3.94	-
AV	2.3882G	46.94	54.00	-7.06	14.70	3	Horizontal	306	1.56	-	28.25	3.99	-
PK	2.4378G	113.35	Inf	-Inf	81.01	3	Horizontal	306	1.56	-	28.30	4.04	-
AV	2.4378G	108.65	Inf	-Inf	76.31	3	Horizontal	306	1.56	-	28.30	4.04	-
PK	2.485G	59.48	74.00	-14.52	26.96	3	Horizontal	306	1.56	-	28.44	4.08	-
AV	2.4858G	50.12	54.00	-3.88	17.59	3	Horizontal	306	1.56	-	28.44	4.09	-

2.4-2.4835GHz_802.11b_Nss1,(1Mbps)_2TX

2437MHz_TX

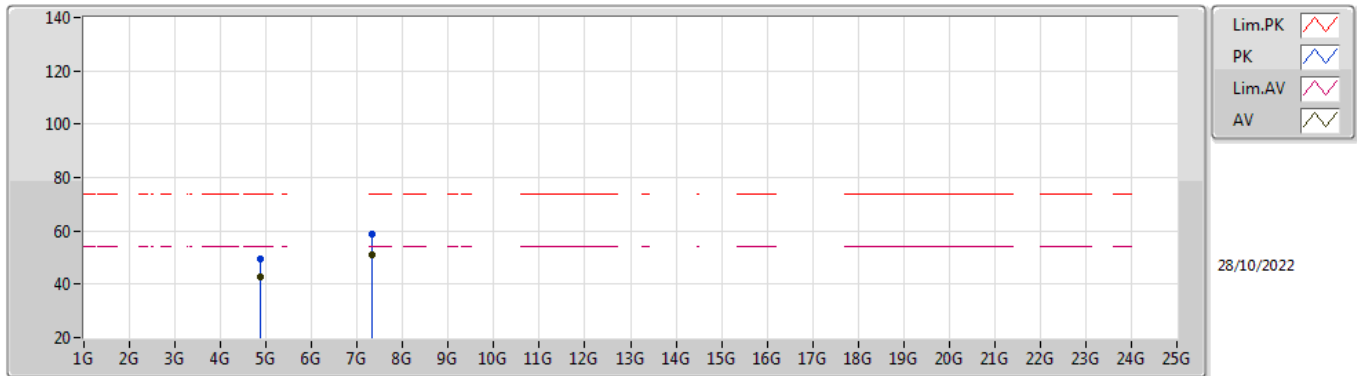

EUT X_2TX
 Setting 23
 03-D-J-8

Type	Freq (Hz)	Level (dBuV/m)	Limit (dBuV/m)	Margin (dB)	Raw (dBuV)	Dist (m)	Condition	Azimuth (°)	Height (m)	Comment	AF (dB)	CL (dB)	PA (dB)
PK	4.87418G	49.72	74.00	-24.28	44.48	3	Vertical	326	1.86	-	33.60	6.54	34.90
AV	4.874G	42.82	54.00	-11.18	37.58	3	Vertical	326	1.86	-	33.60	6.54	34.90
PK	7.3119G	58.96	74.00	-15.04	48.48	3	Vertical	12	1.60	-	36.92	8.70	35.14
AV	7.31172G	51.11	54.00	-2.89	40.63	3	Vertical	12	1.60	-	36.92	8.70	35.14

2.4-2.4835GHz_802.11b_Nss1,(1Mbps)_2TX

2437MHz_TX

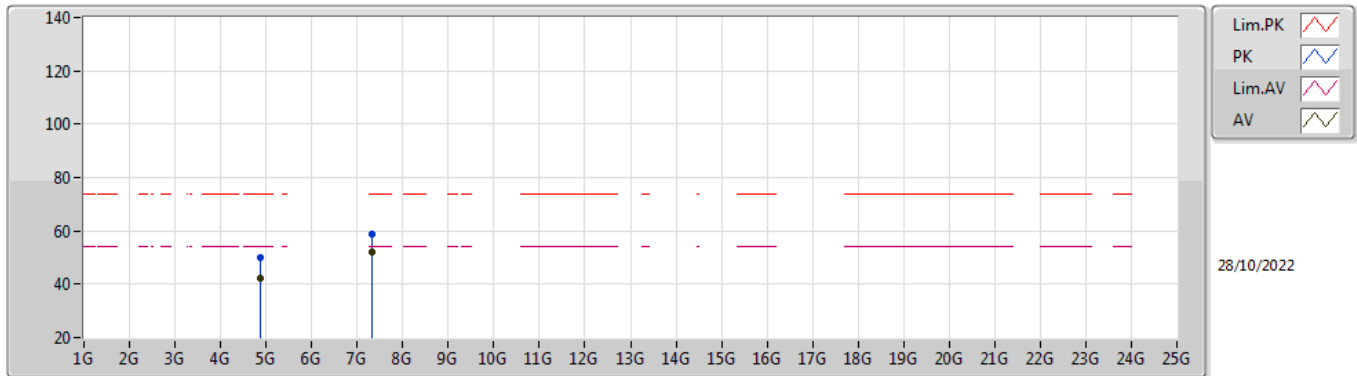

EUT_X_2TX
 Setting 23
 03-D-J-8

Type	Freq (Hz)	Level (dBuV/m)	Limit (dBuV/m)	Margin (dB)	Raw (dBuV)	Dist (m)	Condition	Azimuth (°)	Height (m)	Comment	AF (dB)	CL (dB)	PA (dB)
PK	4.87418G	49.83	74.00	-24.17	44.59	3	Horizontal	18	1.65	-	33.60	6.54	34.90
AV	4.874G	42.06	54.00	-11.94	36.82	3	Horizontal	18	1.65	-	33.60	6.54	34.90
PK	7.31202G	58.65	74.00	-15.35	48.17	3	Horizontal	13	2.04	-	36.92	8.70	35.14
AV	7.31172G	52.01	54.00	-1.99	41.53	3	Horizontal	13	2.04	-	36.92	8.70	35.14

2.4-2.4835GHz_802.11b_Nss1,(1Mbps)_2TX

2457MHz_TX

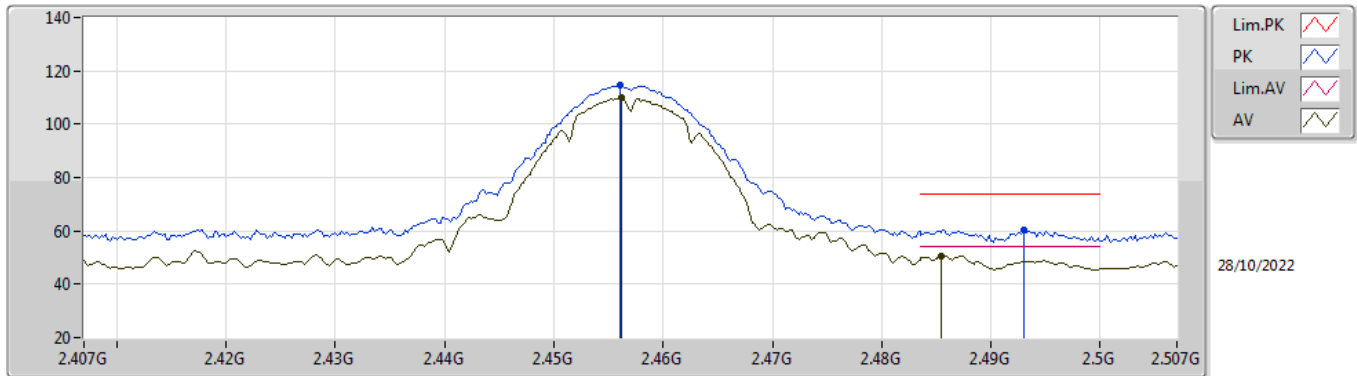

EUT_Y_2TX
Setting 22
03-D-J-8

Type	Freq (Hz)	Level (dBuV/m)	Limit (dBuV/m)	Margin (dB)	Raw (dBuV)	Dist (m)	Condition	Azimuth (°)	Height (m)	Comment	AF (dB)	CL (dB)	PA (dB)
PK	2.456G	114.61	Inf	-Inf	82.23	3	Vertical	307	2.67	-	28.32	4.06	-
AV	2.4562G	109.76	Inf	-Inf	77.38	3	Vertical	307	2.67	-	28.32	4.06	-
PK	2.493G	60.44	74.00	-13.56	27.88	3	Vertical	307	2.67	-	28.47	4.09	-
AV	2.4854G	50.73	54.00	-3.27	18.20	3	Vertical	307	2.67	-	28.44	4.09	-

2.4-2.4835GHz_802.11b_Nss1,(1Mbps)_2TX

2457MHz_TX

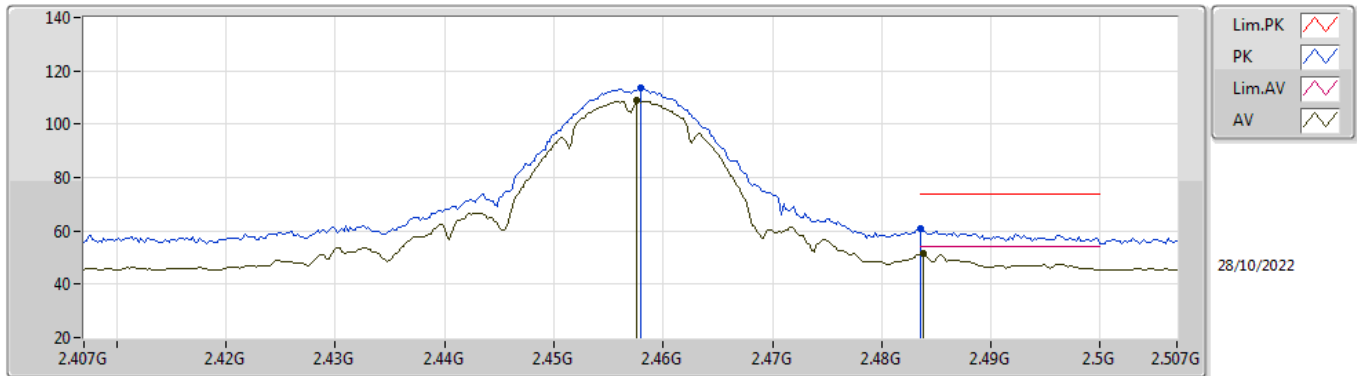

EUT_Y_2TX
 Setting 22
 03-D-J-8

Type	Freq (Hz)	Level (dBuV/m)	Limit (dBuV/m)	Margin (dB)	Raw (dBuV)	Dist (m)	Condition	Azimuth (°)	Height (m)	Comment	AF (dB)	CL (dB)	PA (dB)
PK	2.458G	113.51	Inf	-Inf	81.12	3	Horizontal	289	1.04	-	28.33	4.06	-
AV	2.4576G	108.79	Inf	-Inf	76.40	3	Horizontal	289	1.04	-	28.33	4.06	-
PK	2.4835G	60.65	74.00	-13.35	28.14	3	Horizontal	289	1.04	-	28.43	4.08	-
AV	2.4838G	51.48	54.00	-2.52	18.96	3	Horizontal	289	1.04	-	28.44	4.08	-

2.4-2.4835GHz_802.11b_Nss1,(1Mbps)_2TX

2462MHz_TX

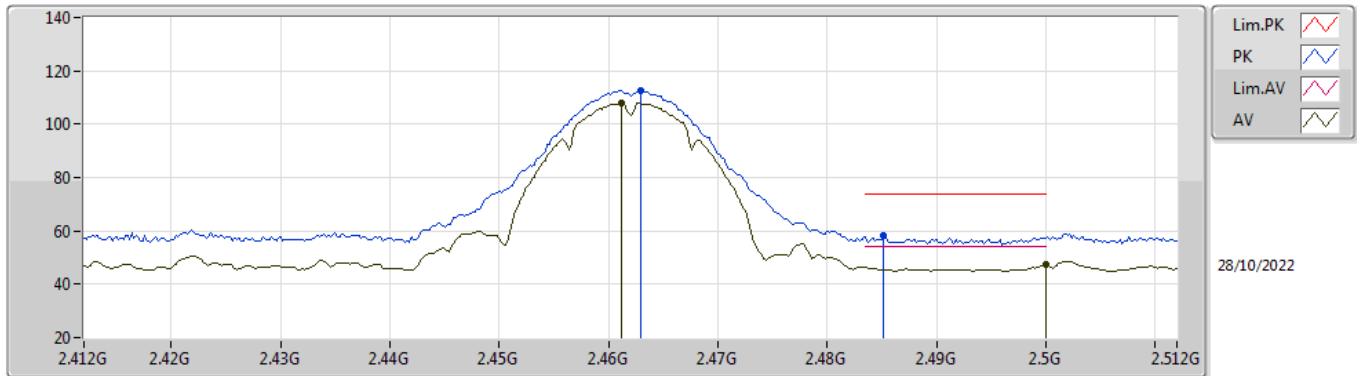

EUT_Y_2TX
 Setting 19
 03-D-J-8

Type	Freq (Hz)	Level (dBuV/m)	Limit (dBuV/m)	Margin (dB)	Raw (dBuV)	Dist (m)	Condition	Azimuth (°)	Height (m)	Comment	AF (dB)	CL (dB)	PA (dB)
PK	2.463G	112.73	Inf	-Inf	80.32	3	Vertical	330	1.86	-	28.35	4.06	-
AV	2.4612G	108.06	Inf	-Inf	75.66	3	Vertical	330	1.86	-	28.34	4.06	-
PK	2.4852G	58.05	74.00	-15.95	25.52	3	Vertical	330	1.86	-	28.44	4.09	-
AV	2.5G	47.27	54.00	-6.73	14.67	3	Vertical	330	1.86	-	28.50	4.10	-

2.4-2.4835GHz_802.11b_Nss1,(1Mbps)_2TX

2462MHz_TX

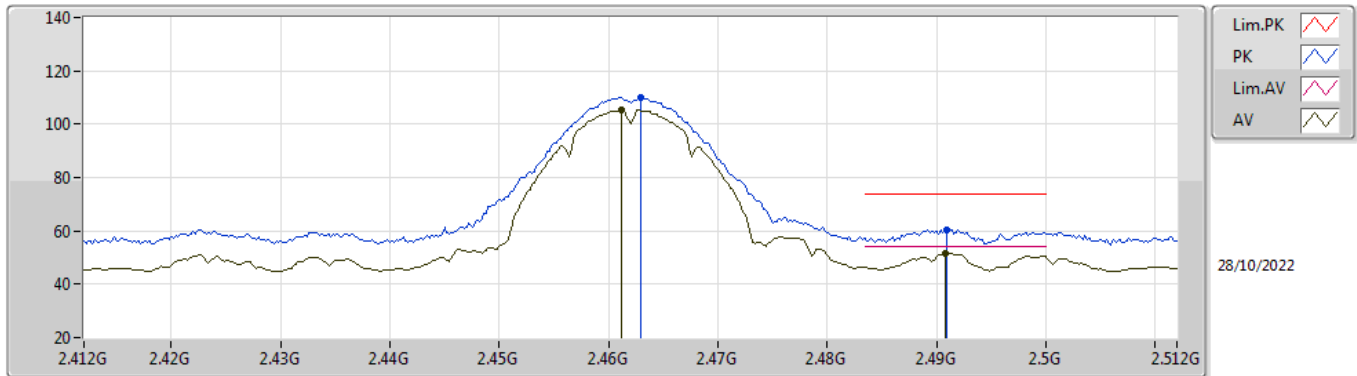

EUT_Y_2TX
Setting 19
03-D-J-8

Type	Freq (Hz)	Level (dBuV/m)	Limit (dBuV/m)	Margin (dB)	Raw (dBuV)	Dist (m)	Condition	Azimuth (°)	Height (m)	Comment	AF (dB)	CL (dB)	PA (dB)
PK	2.463G	110.00	Inf	-Inf	77.59	3	Horizontal	317	1.99	-	28.35	4.06	-
AV	2.4612G	105.48	Inf	-Inf	73.08	3	Horizontal	317	1.99	-	28.34	4.06	-
PK	2.491G	60.56	74.00	-13.44	28.01	3	Horizontal	317	1.99	-	28.46	4.09	-
AV	2.4908G	51.48	54.00	-2.52	18.93	3	Horizontal	317	1.99	-	28.46	4.09	-

2.4-2.4835GHz_802.11b_Nss1,(1Mbps)_2TX

2462MHz_TX

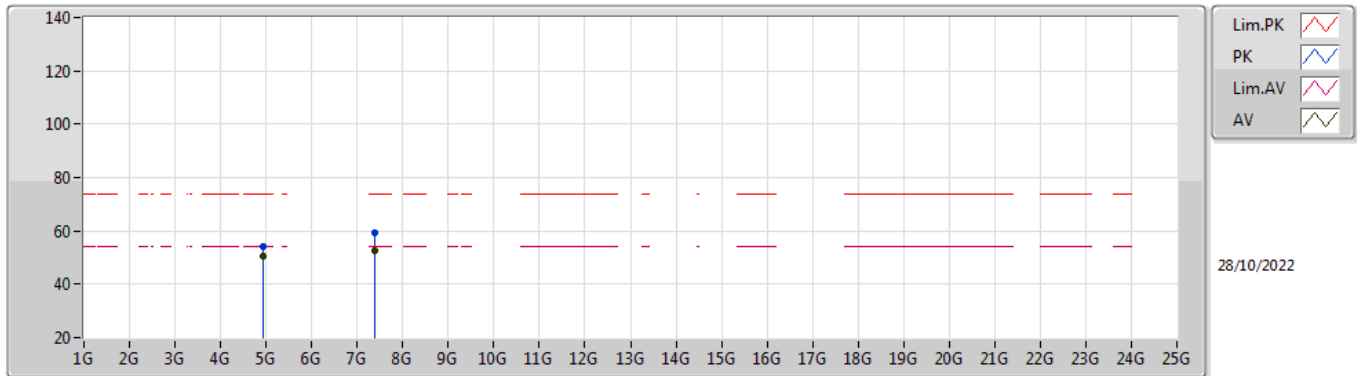

EUT_X_2TX
 Setting 19
 03-D-J-8

Type	Freq (Hz)	Level (dBuV/m)	Limit (dBuV/m)	Margin (dB)	Raw (dBuV)	Dist (m)	Condition	Azimuth (°)	Height (m)	Comment	AF (dB)	CL (dB)	PA (dB)
PK	4.924G	54.02	74.00	-19.98	48.60	3	Vertical	345	1.77	-	33.75	6.56	34.89
AV	4.924G	50.52	54.00	-3.48	45.10	3	Vertical	345	1.77	-	33.75	6.56	34.89
PK	7.38498G	59.33	74.00	-14.67	48.81	3	Vertical	298	1.88	-	37.00	8.70	35.18
AV	7.38672G	52.50	54.00	-1.50	41.98	3	Vertical	298	1.88	-	37.00	8.70	35.18

2.4-2.4835GHz_802.11b_Nss1,(1Mbps)_2TX

2462MHz_TX

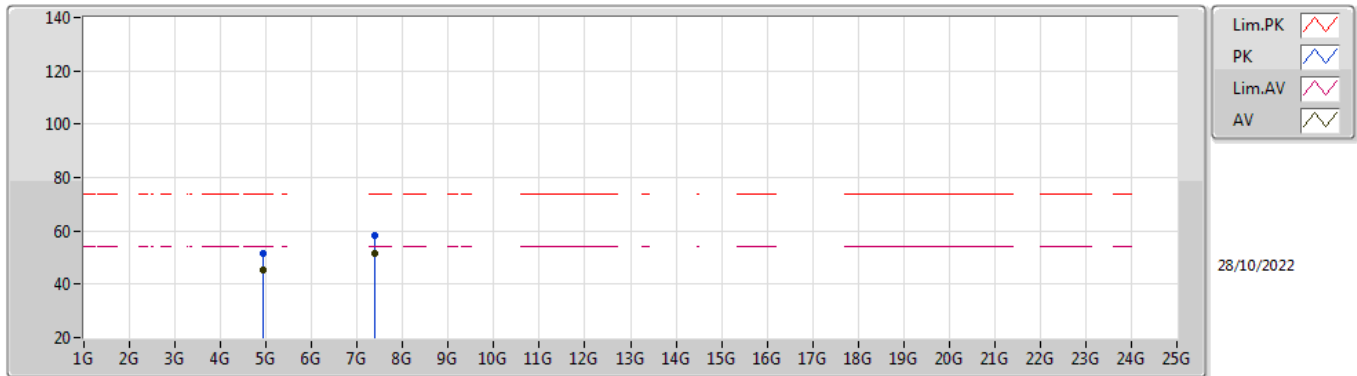

EUT X_2TX
Setting 19
03-D-J-8

Type	Freq (Hz)	Level (dBuV/m)	Limit (dBuV/m)	Margin (dB)	Raw (dBuV)	Dist (m)	Condition	Azimuth (°)	Height (m)	Comment	AF (dB)	CL (dB)	PA (dB)
PK	4.924G	51.39	74.00	-22.61	45.97	3	Horizontal	21	1.75	-	33.75	6.56	34.89
AV	4.924G	45.58	54.00	-8.42	40.16	3	Horizontal	21	1.75	-	33.75	6.56	34.89
PK	7.38636G	58.43	74.00	-15.57	47.91	3	Horizontal	12	1.69	-	37.00	8.70	35.18
AV	7.38672G	51.31	54.00	-2.69	40.79	3	Horizontal	12	1.69	-	37.00	8.70	35.18

2.4-2.4835GHz_802.11g_Nss1,(6Mbps)_2TX

2412MHz_TX

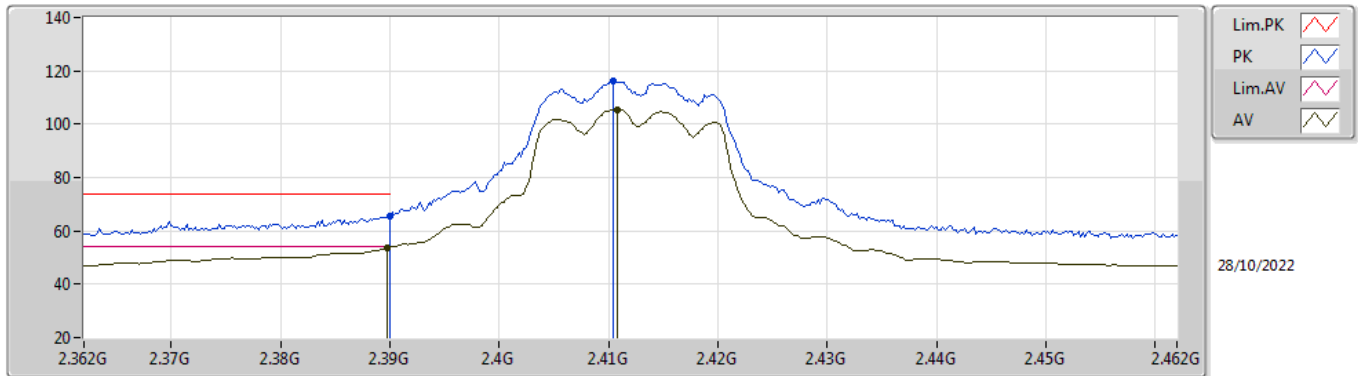

EUT_Y_2TX
Setting 20
03-D-J-8

Type	Freq (Hz)	Level (dBuV/m)	Limit (dBuV/m)	Margin (dB)	Raw (dBuV)	Dist (m)	Condition	Azimuth (°)	Height (m)	Comment	AF (dB)	CL (dB)	PA (dB)
PK	2.39G	65.57	74.00	-8.43	33.32	3	Vertical	327	1.80	-	28.26	3.99	-
AV	2.3898G	53.66	54.00	-0.34	21.41	3	Vertical	327	1.80	-	28.26	3.99	-
PK	2.4104G	116.06	Inf	-Inf	83.75	3	Vertical	327	1.80	-	28.30	4.01	-
AV	2.4108G	105.59	Inf	-Inf	73.28	3	Vertical	327	1.80	-	28.30	4.01	-

2.4-2.4835GHz_802.11g_Nss1,(6Mbps)_2TX

2412MHz_TX

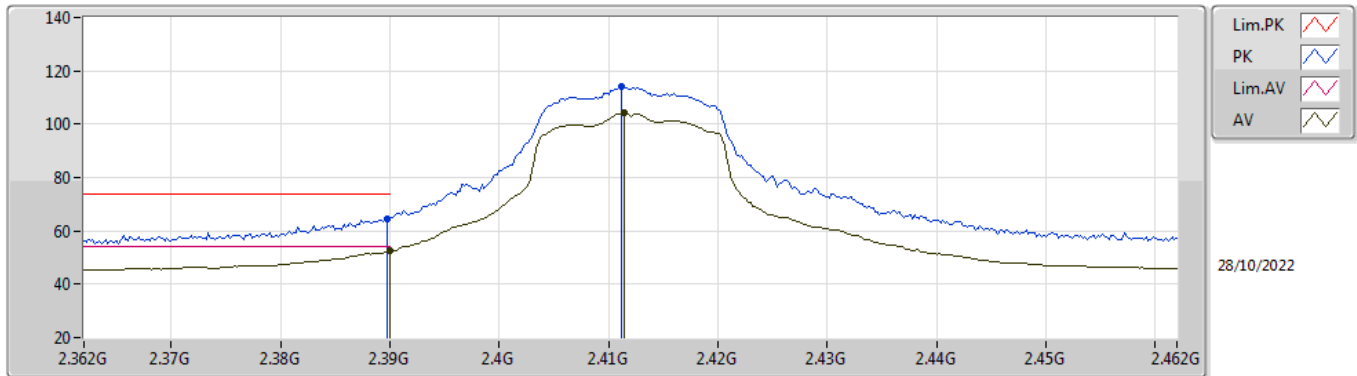

EUT_Y_2TX
Setting 20
03-D-J-8

Type	Freq (Hz)	Level (dBuV/m)	Limit (dBuV/m)	Margin (dB)	Raw (dBuV)	Dist (m)	Condition	Azimuth (°)	Height (m)	Comment	AF (dB)	CL (dB)	PA (dB)
PK	2.3898G	64.64	74.00	-9.36	32.39	3	Horizontal	277	1.39	-	28.26	3.99	-
AV	2.39G	52.52	54.00	-1.48	20.27	3	Horizontal	277	1.39	-	28.26	3.99	-
PK	2.4112G	114.30	Inf	-Inf	81.99	3	Horizontal	277	1.39	-	28.30	4.01	-
AV	2.4114G	104.35	Inf	-Inf	72.04	3	Horizontal	277	1.39	-	28.30	4.01	-

2.4-2.4835GHz_802.11g_Nss1,(6Mbps)_2TX

2412MHz_TX

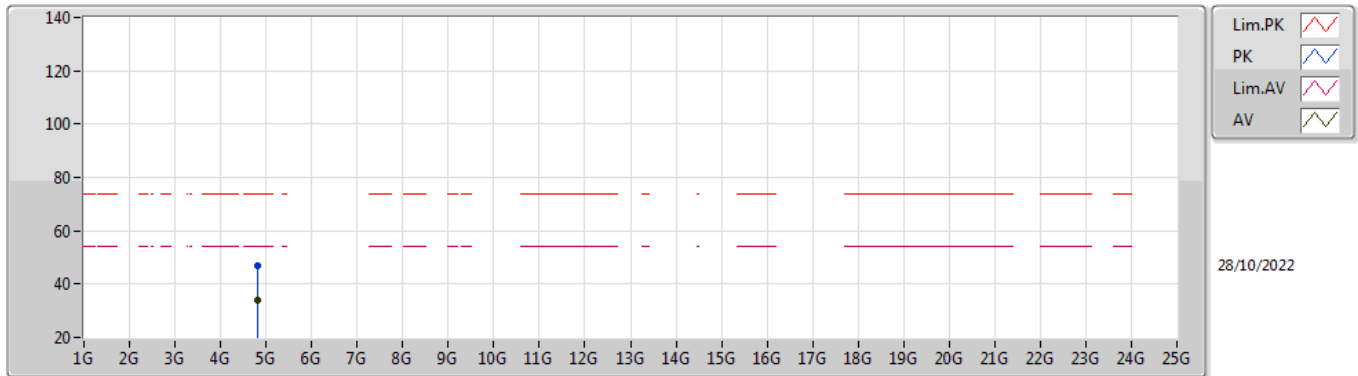

EUT X_2TX
 Setting 20
 03-D-J-8

Type	Freq (Hz)	Level (dBuV/m)	Limit (dBuV/m)	Margin (dB)	Raw (dBuV)	Dist (m)	Condition	Azimuth (°)	Height (m)	Comment	AF (dB)	CL (dB)	PA (dB)
PK	4.82694G	47.04	74.00	-26.96	42.07	3	Vertical	354	1.99	-	33.36	6.51	34.90
AV	4.82394G	34.09	54.00	-19.91	29.14	3	Vertical	354	1.99	-	33.34	6.51	34.90

2.4-2.4835GHz_802.11g_Nss1,(6Mbps)_2TX

2412MHz_TX

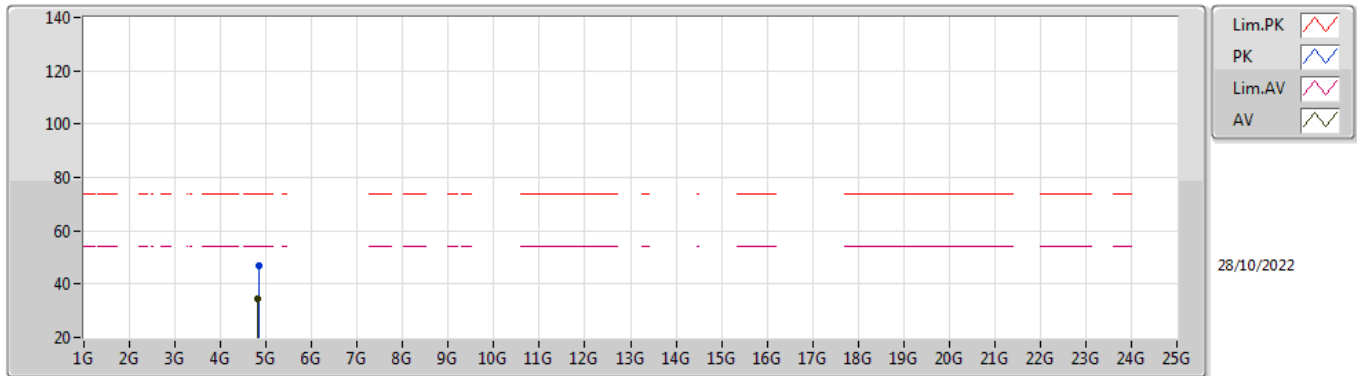

EUT X_2TX
 Setting 20
 03-D-J-8

Type	Freq (Hz)	Level (dBuV/m)	Limit (dBuV/m)	Margin (dB)	Raw (dBuV)	Dist (m)	Condition	Azimuth (°)	Height (m)	Comment	AF (dB)	CL (dB)	PA (dB)
PK	4.83858G	47.07	74.00	-26.93	42.02	3	Horizontal	126	2.13	-	33.43	6.52	34.90
AV	4.82394G	34.35	54.00	-19.65	29.40	3	Horizontal	126	2.13	-	33.34	6.51	34.90

2.4-2.4835GHz_802.11g_Nss1,(6Mbps)_2TX

2437MHz_TX

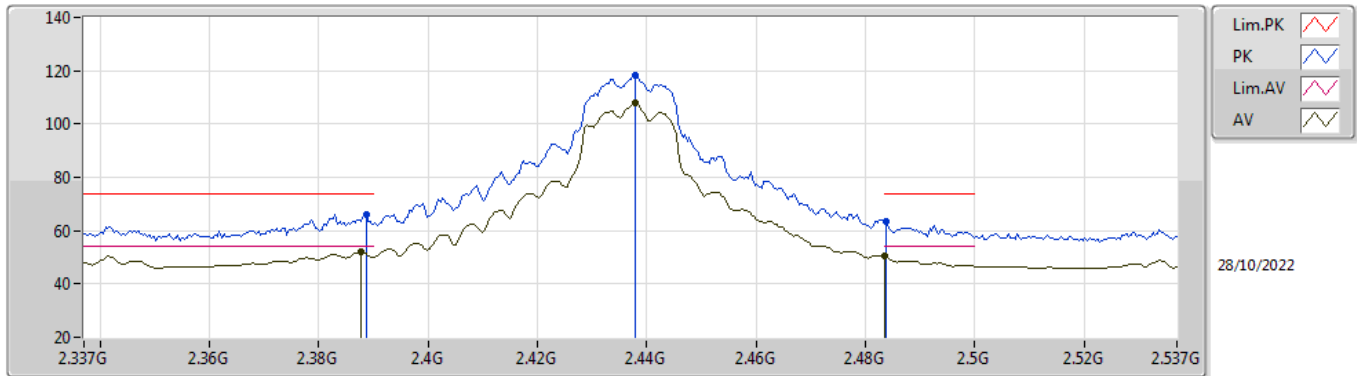

EUT Y_2TX
Setting 22
03-D-J-8

Type	Freq (Hz)	Level (dBuV/m)	Limit (dBuV/m)	Margin (dB)	Raw (dBuV)	Dist (m)	Condition	Azimuth (°)	Height (m)	Comment	AF (dB)	CL (dB)	PA (dB)
PK	2.3886G	65.84	74.00	-8.16	33.60	3	Vertical	297	1.85	-	28.25	3.99	-
AV	2.3878G	51.84	54.00	-2.16	19.60	3	Vertical	297	1.85	-	28.25	3.99	-
PK	2.4378G	118.18	Inf	-Inf	85.84	3	Vertical	297	1.85	-	28.30	4.04	-
AV	2.4378G	107.72	Inf	-Inf	75.38	3	Vertical	297	1.85	-	28.30	4.04	-
PK	2.4838G	63.26	74.00	-10.74	30.74	3	Vertical	297	1.85	-	28.44	4.08	-
AV	2.4835G	50.39	54.00	-3.61	17.88	3	Vertical	297	1.85	-	28.43	4.08	-

2.4-2.4835GHz_802.11g_Nss1,(6Mbps)_2TX

2437MHz_TX

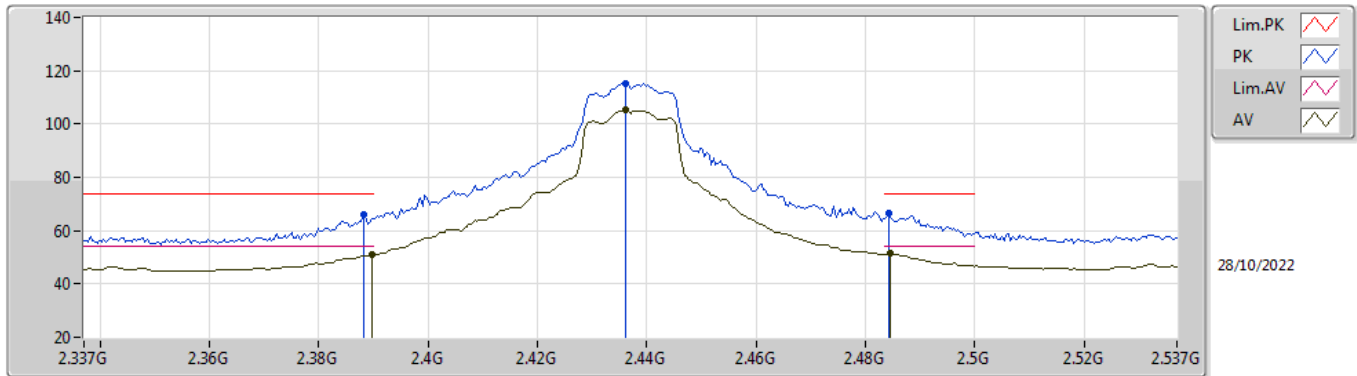

EUT Y_2TX
 Setting 22
 03-D-J-8

Type	Freq (Hz)	Level (dBuV/m)	Limit (dBuV/m)	Margin (dB)	Raw (dBuV)	Dist (m)	Condition	Azimuth (°)	Height (m)	Comment	AF (dB)	CL (dB)	PA (dB)
PK	2.3882G	65.78	74.00	-8.22	33.54	3	Horizontal	294	1.40	-	28.25	3.99	-
AV	2.3898G	51.01	54.00	-2.99	18.76	3	Horizontal	294	1.40	-	28.26	3.99	-
PK	2.4362G	115.37	Inf	-Inf	83.03	3	Horizontal	294	1.40	-	28.30	4.04	-
AV	2.4362G	105.28	Inf	-Inf	72.94	3	Horizontal	294	1.40	-	28.30	4.04	-
PK	2.4842G	66.46	74.00	-7.54	33.94	3	Horizontal	294	1.40	-	28.44	4.08	-
AV	2.4846G	51.38	54.00	-2.62	18.86	3	Horizontal	294	1.40	-	28.44	4.08	-

2.4-2.4835GHz_802.11g_Nss1,(6Mbps)_2TX

2437MHz_TX

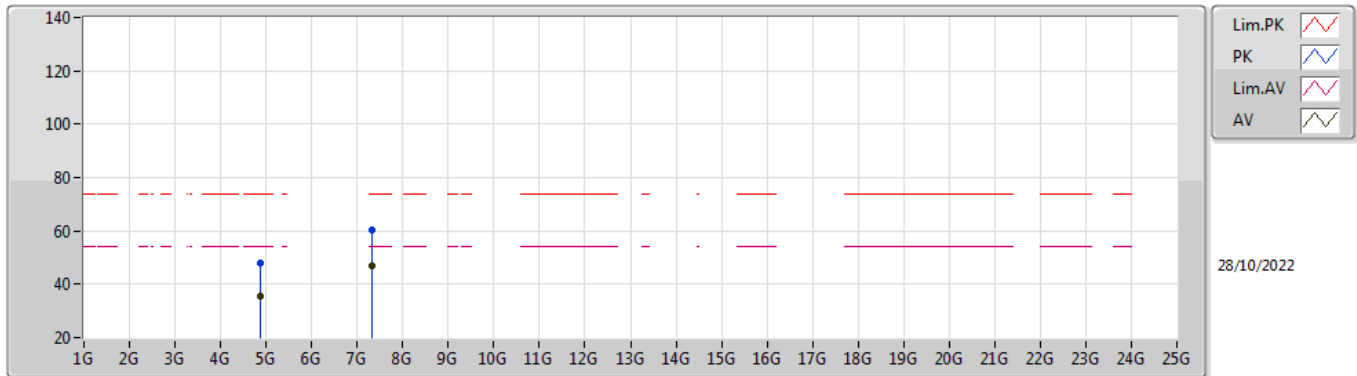

EUT_X_2TX
 Setting 22
 03-D-J-8

Type	Freq (Hz)	Level (dBuV/m)	Limit (dBuV/m)	Margin (dB)	Raw (dBuV)	Dist (m)	Condition	Azimuth (°)	Height (m)	Comment	AF (dB)	CL (dB)	PA (dB)
PK	4.8737G	47.99	74.00	-26.01	42.76	3	Vertical	341	2.42	-	33.59	6.54	34.90
AV	4.87406G	35.50	54.00	-18.50	30.26	3	Vertical	341	2.42	-	33.60	6.54	34.90
PK	7.31292G	60.33	74.00	-13.67	49.84	3	Vertical	301	1.80	-	36.93	8.70	35.14
AV	7.3131G	46.83	54.00	-7.17	36.34	3	Vertical	301	1.80	-	36.93	8.70	35.14

2.4-2.4835GHz_802.11g_Nss1,(6Mbps)_2TX

2437MHz_TX

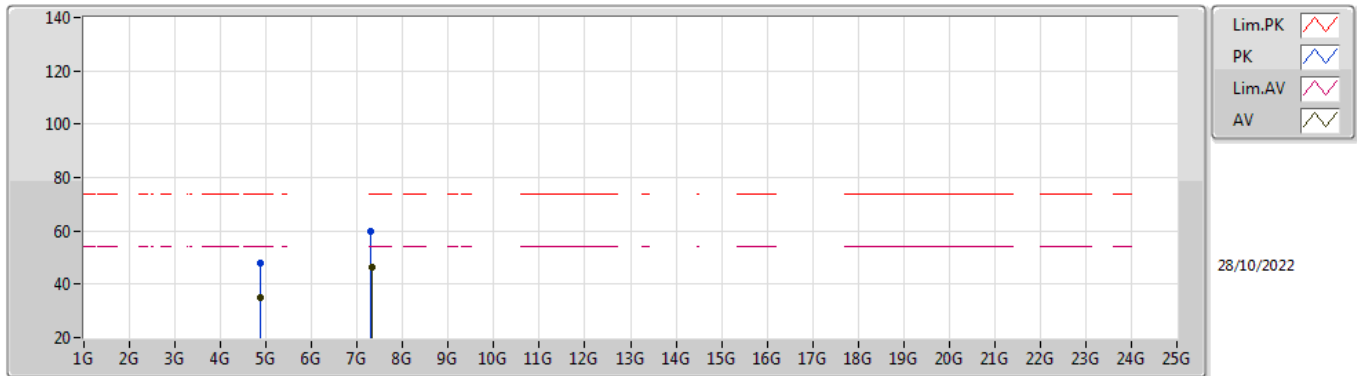

EUT_X_2TX
Setting 22
03-D-J-8

Type	Freq (Hz)	Level (dBuV/m)	Limit (dBuV/m)	Margin (dB)	Raw (dBuV)	Dist (m)	Condition	Azimuth (°)	Height (m)	Comment	AF (dB)	CL (dB)	PA (dB)
PK	4.874G	47.91	74.00	-26.09	42.67	3	Horizontal	128	2.00	-	33.60	6.54	34.90
AV	4.87394G	35.23	54.00	-18.77	29.99	3	Horizontal	128	2.00	-	33.60	6.54	34.90
PK	7.30788G	60.07	74.00	-13.93	49.59	3	Horizontal	9	2.27	-	36.92	8.70	35.14
AV	7.31304G	46.34	54.00	-7.66	35.85	3	Horizontal	9	2.27	-	36.93	8.70	35.14

2.4-2.4835GHz_802.11g_Nss1,(6Mbps)_2TX

2457MHz_TX

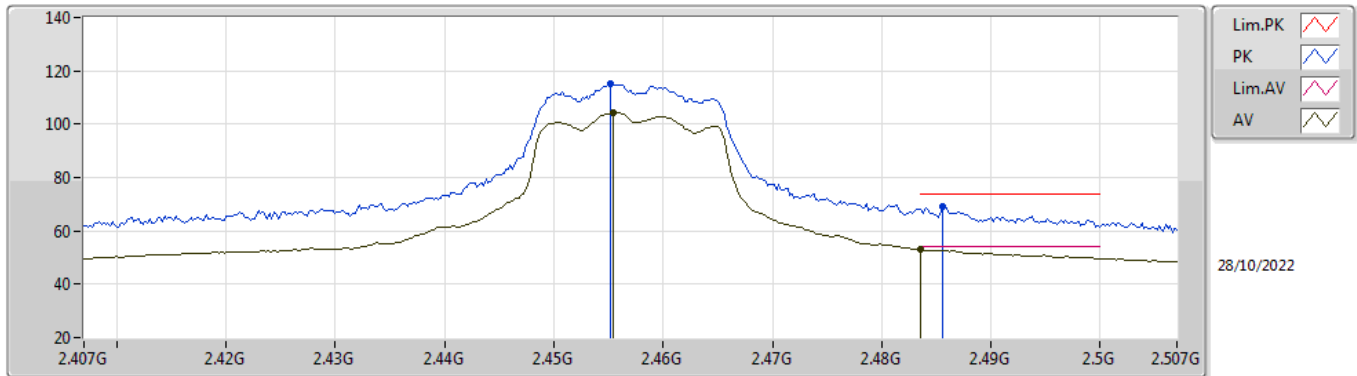

EUT_Y_2TX
Setting 18
03-D-J-8

Type	Freq (Hz)	Level (dBuV/m)	Limit (dBuV/m)	Margin (dB)	Raw (dBuV)	Dist (m)	Condition	Azimuth (°)	Height (m)	Comment	AF (dB)	CL (dB)	PA (dB)
PK	2.4552G	115.42	Inf	-Inf	83.04	3	Vertical	298	2.08	-	28.32	4.06	-
AV	2.4554G	104.34	Inf	-Inf	71.96	3	Vertical	298	2.08	-	28.32	4.06	-
PK	2.4856G	69.22	74.00	-4.78	36.69	3	Vertical	298	2.08	-	28.44	4.09	-
AV	2.4835G	52.97	54.00	-1.03	20.46	3	Vertical	298	2.08	-	28.43	4.08	-

2.4-2.4835GHz_802.11g_Nss1,(6Mbps)_2TX

2457MHz_TX

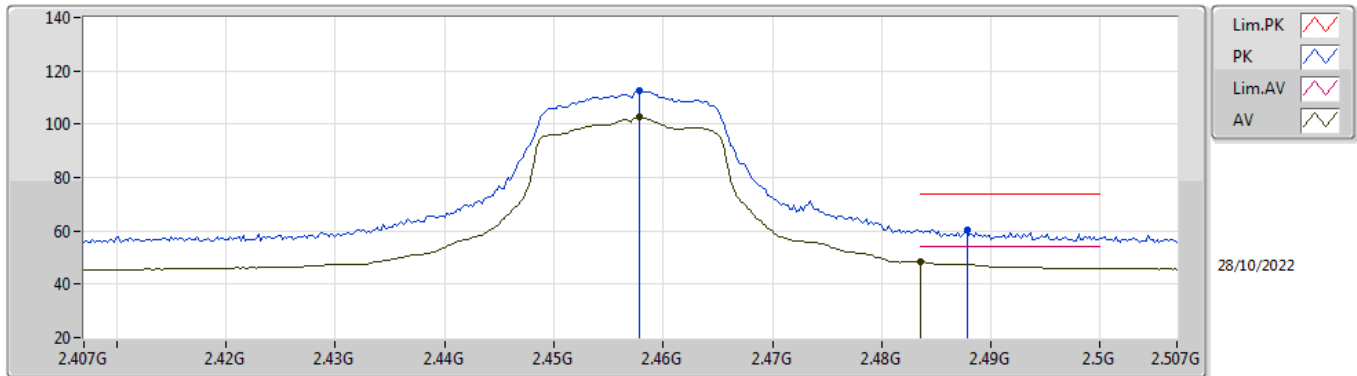

EUT_Y_2TX
 Setting 18
 03-D-J-8

Type	Freq (Hz)	Level (dBuV/m)	Limit (dBuV/m)	Margin (dB)	Raw (dBuV)	Dist (m)	Condition	Azimuth (°)	Height (m)	Comment	AF (dB)	CL (dB)	PA (dB)
PK	2.4578G	112.37	Inf	-Inf	79.98	3	Horizontal	316	1.02	-	28.33	4.06	-
AV	2.4578G	102.58	Inf	-Inf	70.19	3	Horizontal	316	1.02	-	28.33	4.06	-
PK	2.4878G	60.40	74.00	-13.60	27.86	3	Horizontal	316	1.02	-	28.45	4.09	-
AV	2.4835G	48.50	54.00	-5.50	15.99	3	Horizontal	316	1.02	-	28.43	4.08	-

2.4-2.4835GHz_802.11g_Nss1,(6Mbps)_2TX

2462MHz_TX

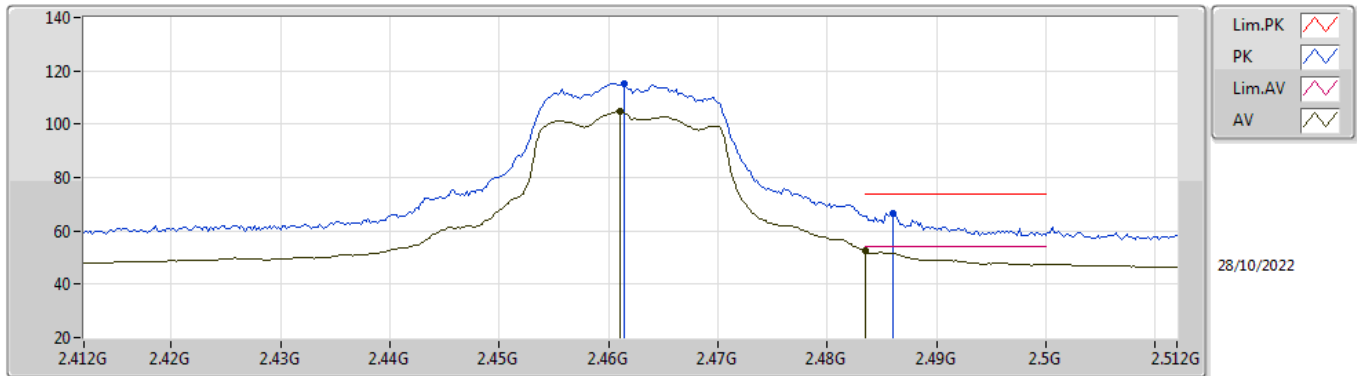

EUT_Y_2TX
Setting 18
03-D-J-8

Type	Freq (Hz)	Level (dBuV/m)	Limit (dBuV/m)	Margin (dB)	Raw (dBuV)	Dist (m)	Condition	Azimuth (°)	Height (m)	Comment	AF (dB)	CL (dB)	PA (dB)
PK	2.4614G	115.19	Inf	-Inf	82.78	3	Vertical	313	2.08	-	28.35	4.06	-
AV	2.461G	104.69	Inf	-Inf	72.29	3	Vertical	313	2.08	-	28.34	4.06	-
PK	2.486G	66.79	74.00	-7.21	34.26	3	Vertical	313	2.08	-	28.44	4.09	-
AV	2.4835G	52.58	54.00	-1.42	20.07	3	Vertical	313	2.08	-	28.43	4.08	-

2.4-2.4835GHz_802.11g_Nss1,(6Mbps)_2TX

2462MHz_TX

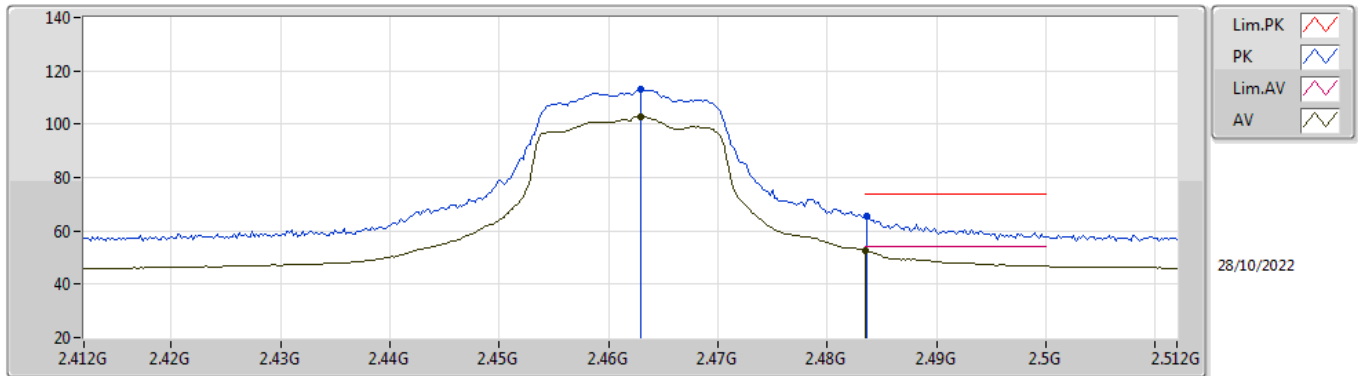

EUT_Y_2TX
Setting 18
03-D-J-8

Type	Freq (Hz)	Level (dBuV/m)	Limit (dBuV/m)	Margin (dB)	Raw (dBuV)	Dist (m)	Condition	Azimuth (°)	Height (m)	Comment	AF (dB)	CL (dB)	PA (dB)
PK	2.463G	113.09	Inf	-Inf	80.68	3	Horizontal	315	1.03	-	28.35	4.06	-
AV	2.463G	103.01	Inf	-Inf	70.60	3	Horizontal	315	1.03	-	28.35	4.06	-
PK	2.4836G	65.63	74.00	-8.37	33.12	3	Horizontal	315	1.03	-	28.43	4.08	-
AV	2.4835G	52.52	54.00	-1.48	20.01	3	Horizontal	315	1.03	-	28.43	4.08	-

2.4-2.4835GHz_802.11g_Nss1,(6Mbps)_2TX

2462MHz_TX

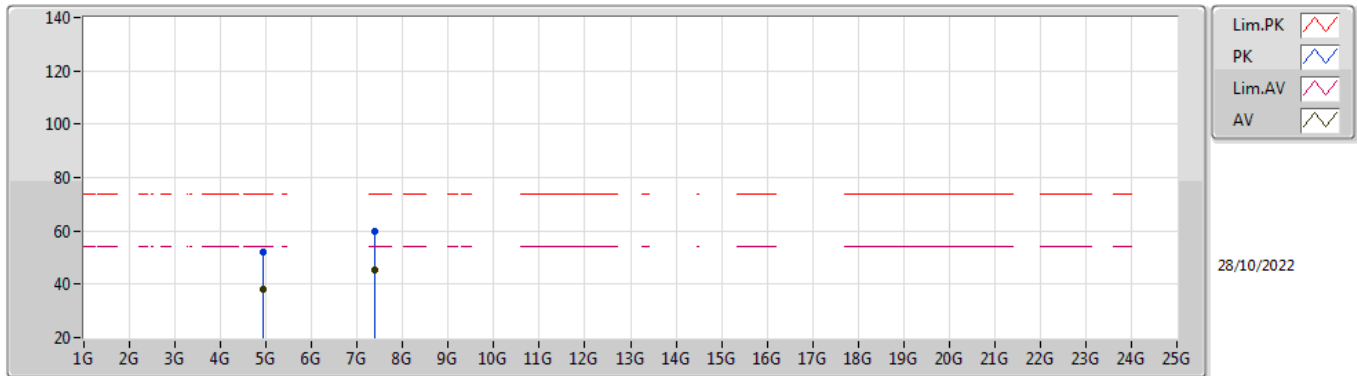

EUT X_2TX
Setting 18
03-D-J-8

Type	Freq (Hz)	Level (dBuV/m)	Limit (dBuV/m)	Margin (dB)	Raw (dBuV)	Dist (m)	Condition	Azimuth (°)	Height (m)	Comment	AF (dB)	CL (dB)	PA (dB)
PK	4.92706G	52.20	74.00	-21.80	46.78	3	Vertical	341	1.80	-	33.75	6.56	34.89
AV	4.92184G	38.36	54.00	-15.64	32.95	3	Vertical	341	1.80	-	33.74	6.56	34.89
PK	7.38408G	59.77	74.00	-14.23	49.25	3	Vertical	302	1.80	-	37.00	8.70	35.18
AV	7.38336G	45.50	54.00	-8.50	34.98	3	Vertical	302	1.80	-	37.00	8.70	35.18

2.4-2.4835GHz_802.11g_Nss1,(6Mbps)_2TX

2462MHz_TX

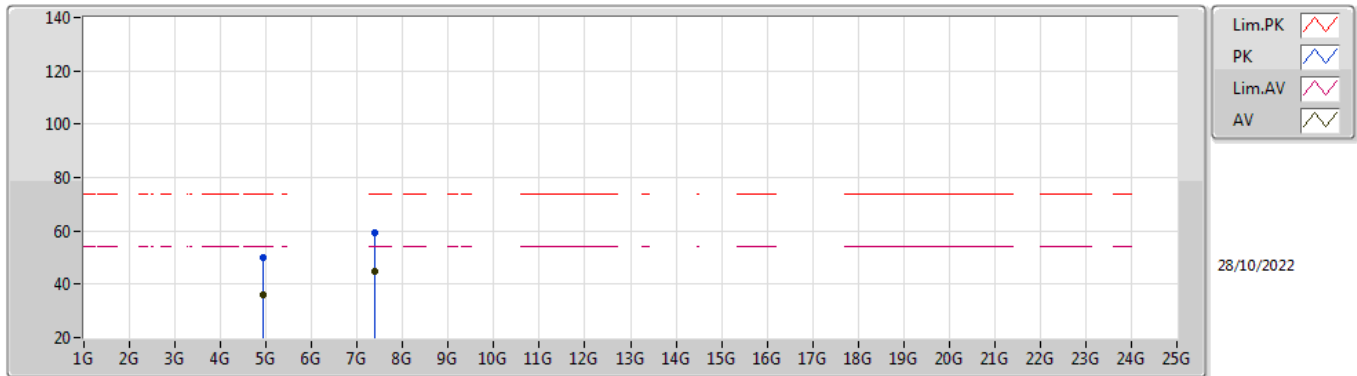

EUT_X_2TX
 Setting 18
 03-D-J-8

Type	Freq (Hz)	Level (dBuV/m)	Limit (dBuV/m)	Margin (dB)	Raw (dBuV)	Dist (m)	Condition	Azimuth (°)	Height (m)	Comment	AF (dB)	CL (dB)	PA (dB)
PK	4.9243G	50.18	74.00	-23.82	44.76	3	Horizontal	24	2.04	-	33.75	6.56	34.89
AV	4.924G	36.20	54.00	-17.80	30.78	3	Horizontal	24	2.04	-	33.75	6.56	34.89
PK	7.38744G	59.08	74.00	-14.92	48.56	3	Horizontal	10	1.77	-	37.00	8.70	35.18
AV	7.38822G	45.06	54.00	-8.94	34.54	3	Horizontal	10	1.77	-	37.00	8.70	35.18

2.4-2.4835GHz_802.11ax HEW20_Nss1,(MCS0)_2TX

2412MHz_TX

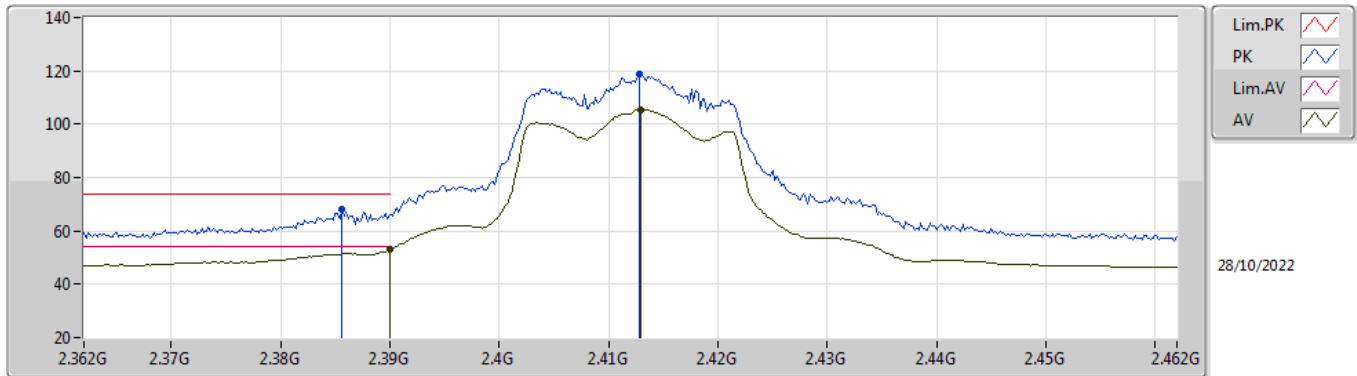

EUT_Y_2TX
 Setting 19.5
 03-D-J-8

Type	Freq (Hz)	Level (dBuV/m)	Limit (dBuV/m)	Margin (dB)	Raw (dBuV)	Dist (m)	Condition	Azimuth (°)	Height (m)	Comment	AF (dB)	CL (dB)	PA (dB)
PK	2.3856G	68.26	74.00	-5.74	36.03	3	Vertical	329	1.71	-	28.24	3.99	-
AV	2.39G	53.33	54.00	-0.67	21.08	3	Vertical	329	1.71	-	28.26	3.99	-
PK	2.4128G	118.97	Inf	-Inf	86.66	3	Vertical	329	1.71	-	28.30	4.01	-
AV	2.413G	105.35	Inf	-Inf	73.04	3	Vertical	329	1.71	-	28.30	4.01	-

2.4-2.4835GHz_802.11ax HEW20_Nss1,(MCS0)_2TX

2412MHz_TX

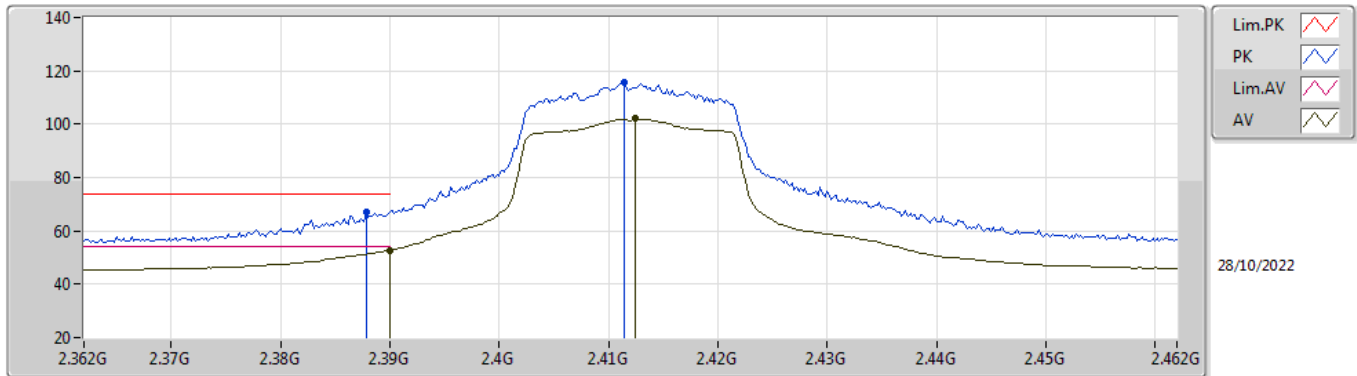

EUT_Y_2TX
 Setting 19.5
 03-D-J-8

Type	Freq (Hz)	Level (dBuV/m)	Limit (dBuV/m)	Margin (dB)	Raw (dBuV)	Dist (m)	Condition	Azimuth (°)	Height (m)	Comment	AF (dB)	CL (dB)	PA (dB)
PK	2.3878G	66.96	74.00	-7.04	34.72	3	Horizontal	307	1.62	-	28.25	3.99	-
AV	2.39G	52.65	54.00	-1.35	20.40	3	Horizontal	307	1.62	-	28.26	3.99	-
PK	2.4114G	115.50	Inf	-Inf	83.19	3	Horizontal	307	1.62	-	28.30	4.01	-
AV	2.4124G	102.00	Inf	-Inf	69.69	3	Horizontal	307	1.62	-	28.30	4.01	-

2.4-2.4835GHz_802.11ax HEW20_Nss1,(MCS0)_2TX

2412MHz_TX

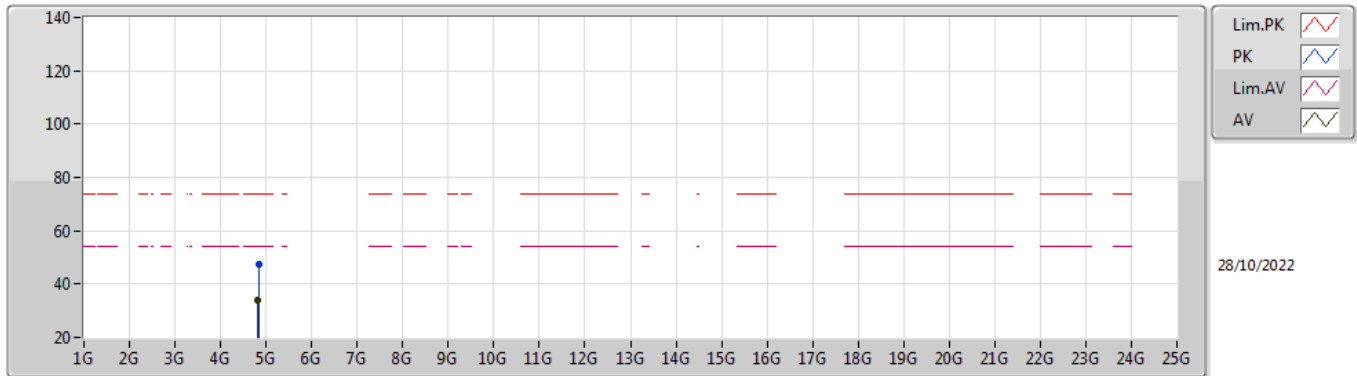

EUT X_2TX
 Setting 19.5
 03-D-J-8

Type	Freq (Hz)	Level (dBuV/m)	Limit (dBuV/m)	Margin (dB)	Raw (dBuV)	Dist (m)	Condition	Azimuth (°)	Height (m)	Comment	AF (dB)	CL (dB)	PA (dB)
PK	4.83072G	47.48	74.00	-26.52	42.48	3	Vertical	358	1.80	-	33.38	6.52	34.90
AV	4.82394G	34.06	54.00	-19.94	29.11	3	Vertical	358	1.80	-	33.34	6.51	34.90

2.4-2.4835GHz_802.11ax HEW20_Nss1,(MCS0)_2TX

2412MHz_TX

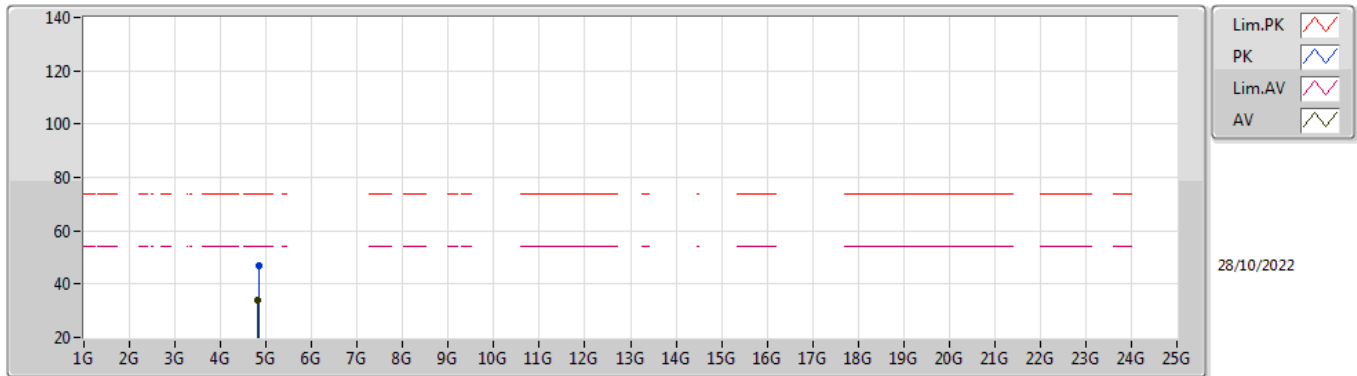

EUT X_2TX
Setting 19.5
03-D-J-8

Type	Freq (Hz)	Level (dBuV/m)	Limit (dBuV/m)	Margin (dB)	Raw (dBuV)	Dist (m)	Condition	Azimuth (°)	Height (m)	Comment	AF (dB)	CL (dB)	PA (dB)
PK	4.8318G	47.12	74.00	-26.88	42.11	3	Horizontal	86	2.13	-	33.39	6.52	34.90
AV	4.824G	33.88	54.00	-20.12	28.93	3	Horizontal	86	2.13	-	33.34	6.51	34.90

2.4-2.4835GHz_802.11ax HEW20_Nss1,(MCS0)_2TX

2437MHz_TX

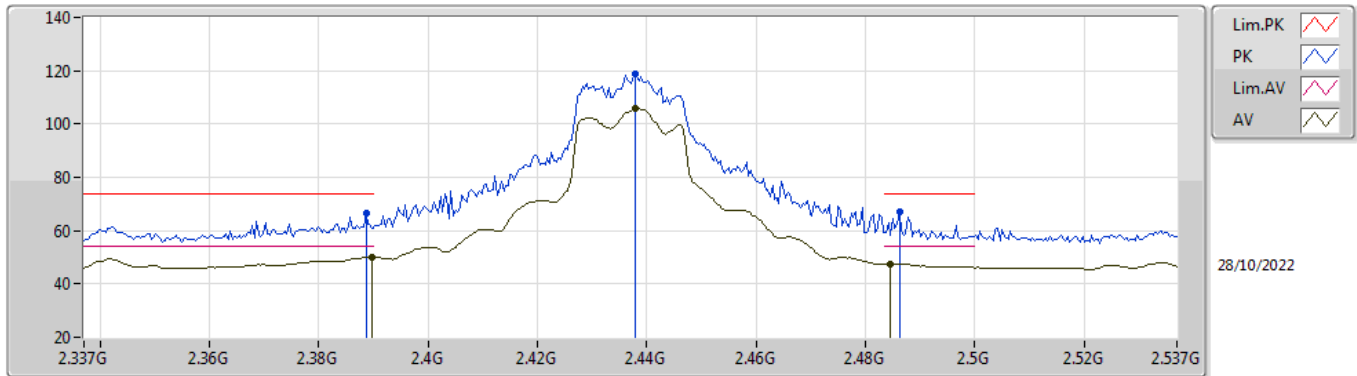

EUT Y_2TX
 Setting 21
 03-D-J-8

Type	Freq (Hz)	Level (dBuV/m)	Limit (dBuV/m)	Margin (dB)	Raw (dBuV)	Dist (m)	Condition	Azimuth (°)	Height (m)	Comment	AF (dB)	CL (dB)	PA (dB)
PK	2.3886G	66.37	74.00	-7.63	34.13	3	Vertical	292	1.80	-	28.25	3.99	-
AV	2.3898G	49.91	54.00	-4.09	17.66	3	Vertical	292	1.80	-	28.26	3.99	-
PK	2.4378G	118.98	Inf	-Inf	86.64	3	Vertical	292	1.80	-	28.30	4.04	-
AV	2.4378G	105.99	Inf	-Inf	73.65	3	Vertical	292	1.80	-	28.30	4.04	-
PK	2.4862G	66.93	74.00	-7.07	34.40	3	Vertical	292	1.80	-	28.44	4.09	-
AV	2.4846G	47.47	54.00	-6.53	14.95	3	Vertical	292	1.80	-	28.44	4.08	-

2.4-2.4835GHz_802.11ax HEW20_Nss1,(MCS0)_2TX

2437MHz_TX

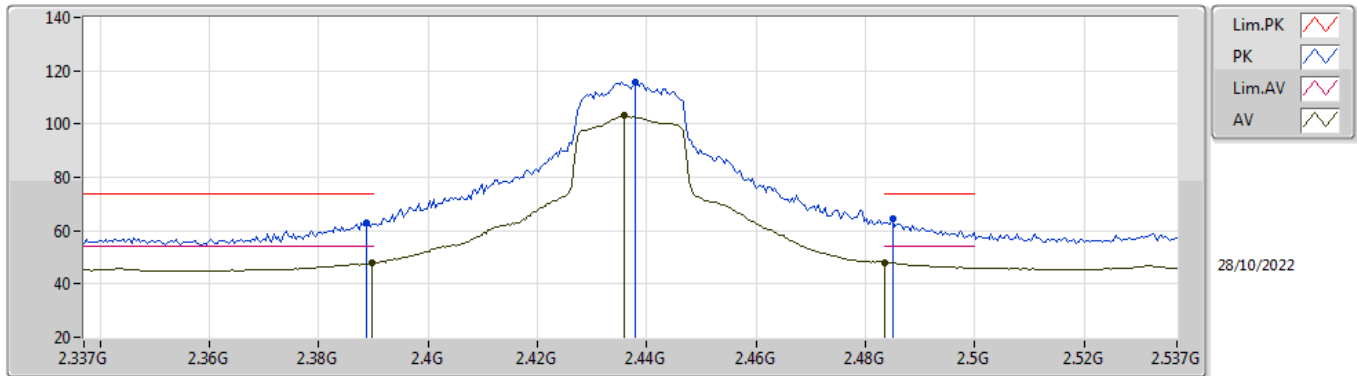

EUT Y_2TX
 Setting 21
 03-D-J-8

Type	Freq (Hz)	Level (dBuV/m)	Limit (dBuV/m)	Margin (dB)	Raw (dBuV)	Dist (m)	Condition	Azimuth (°)	Height (m)	Comment	AF (dB)	CL (dB)	PA (dB)
PK	2.3886G	63.02	74.00	-10.98	30.78	3	Horizontal	296	1.42	-	28.25	3.99	-
AV	2.3898G	47.82	54.00	-6.18	15.57	3	Horizontal	296	1.42	-	28.26	3.99	-
PK	2.4378G	115.79	Inf	-Inf	83.45	3	Horizontal	296	1.42	-	28.30	4.04	-
AV	2.4358G	103.12	Inf	-Inf	70.78	3	Horizontal	296	1.42	-	28.30	4.04	-
PK	2.485G	64.27	74.00	-9.73	31.75	3	Horizontal	296	1.42	-	28.44	4.08	-
AV	2.4835G	48.13	54.00	-5.87	15.62	3	Horizontal	296	1.42	-	28.43	4.08	-

2.4-2.4835GHz_802.11ax HEW20_Nss1,(MCS0)_2TX

2437MHz_TX

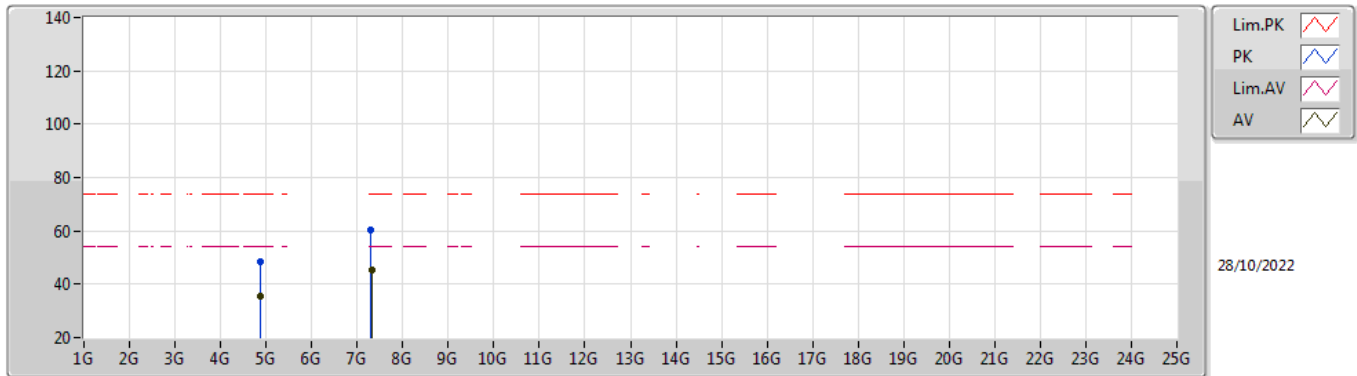

EUT_X_2TX
 Setting 21
 03-D-J-8

Type	Freq (Hz)	Level (dBuV/m)	Limit (dBuV/m)	Margin (dB)	Raw (dBuV)	Dist (m)	Condition	Azimuth (°)	Height (m)	Comment	AF (dB)	CL (dB)	PA (dB)
PK	4.8671G	48.69	74.00	-25.31	43.49	3	Vertical	344	1.80	-	33.57	6.53	34.90
AV	4.8788G	35.35	54.00	-18.65	30.08	3	Vertical	344	1.80	-	33.62	6.54	34.89
PK	7.30656G	60.17	74.00	-13.83	49.70	3	Vertical	304	1.61	-	36.91	8.70	35.14
AV	7.31592G	45.25	54.00	-8.75	34.77	3	Vertical	304	1.61	-	36.93	8.70	35.15

2.4-2.4835GHz_802.11ax HEW20_Nss1,(MCS0)_2TX

2437MHz_TX

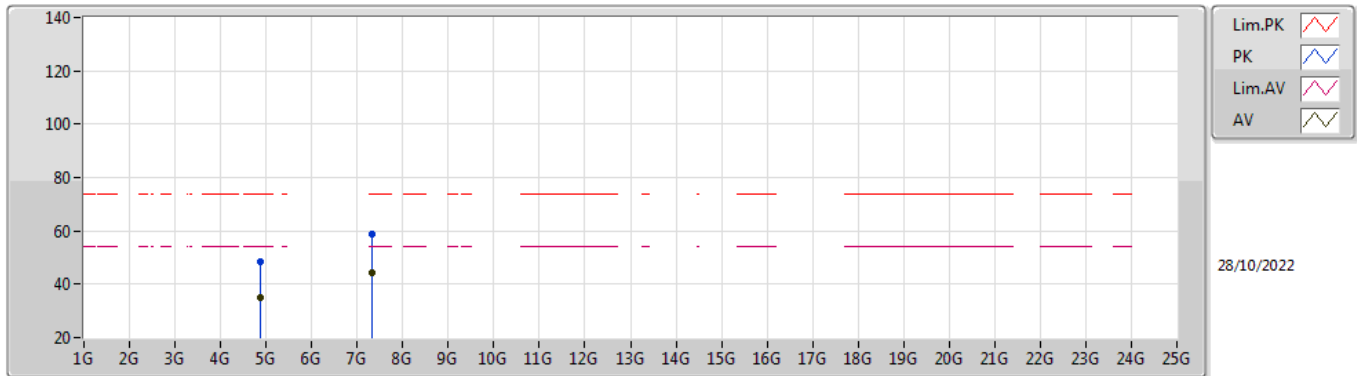

EUT_X_2TX
Setting 21
03-D-J-8

Type	Freq (Hz)	Level (dBuV/m)	Limit (dBuV/m)	Margin (dB)	Raw (dBuV)	Dist (m)	Condition	Azimuth (°)	Height (m)	Comment	AF (dB)	CL (dB)	PA (dB)
PK	4.87664G	48.31	74.00	-25.69	43.05	3	Horizontal	131	2.00	-	33.61	6.54	34.89
AV	4.87406G	35.23	54.00	-18.77	29.99	3	Horizontal	131	2.00	-	33.60	6.54	34.90
PK	7.31658G	58.99	74.00	-15.01	48.51	3	Horizontal	17	1.98	-	36.93	8.70	35.15
AV	7.31574G	44.37	54.00	-9.63	33.89	3	Horizontal	17	1.98	-	36.93	8.70	35.15

2.4-2.4835GHz_802.11ax HEW20_Nss1,(MCS0)_2TX

2457MHz_TX

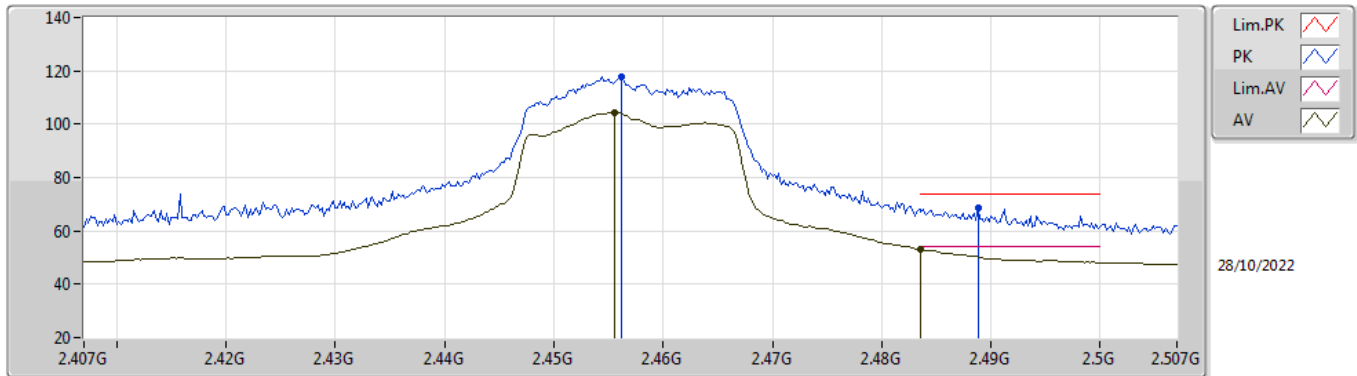

EUT_Y_2TX
Setting 18.5
03-D-J-8

Type	Freq (Hz)	Level (dBuV/m)	Limit (dBuV/m)	Margin (dB)	Raw (dBuV)	Dist (m)	Condition	Azimuth (°)	Height (m)	Comment	AF (dB)	CL (dB)	PA (dB)
PK	2.4562G	117.70	Inf	-Inf	85.32	3	Vertical	299	2.07	-	28.32	4.06	-
AV	2.4556G	104.40	Inf	-Inf	72.02	3	Vertical	299	2.07	-	28.32	4.06	-
PK	2.4888G	68.39	74.00	-5.61	35.84	3	Vertical	299	2.07	-	28.46	4.09	-
AV	2.4835G	53.20	54.00	-0.80	20.69	3	Vertical	299	2.07	-	28.43	4.08	-

2.4-2.4835GHz_802.11ax HEW20_Nss1,(MCS0)_2TX

2457MHz_TX

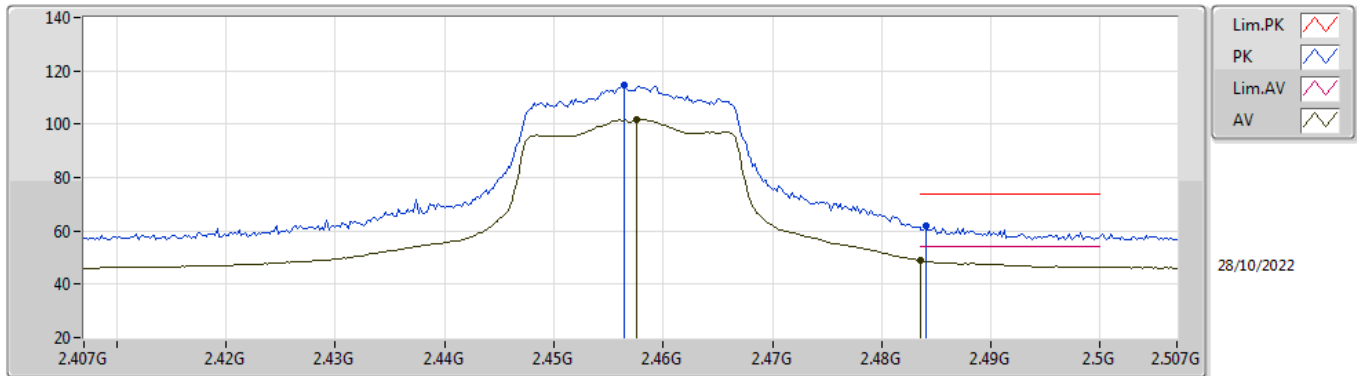

EUT_Y_2TX
Setting 18.5
03-D-J-8

Type	Freq (Hz)	Level (dBuV/m)	Limit (dBuV/m)	Margin (dB)	Raw (dBuV)	Dist (m)	Condition	Azimuth (°)	Height (m)	Comment	AF (dB)	CL (dB)	PA (dB)
PK	2.4564G	114.55	Inf	-Inf	82.16	3	Horizontal	291	1.00	-	28.33	4.06	-
AV	2.4576G	101.85	Inf	-Inf	69.46	3	Horizontal	291	1.00	-	28.33	4.06	-
PK	2.484G	61.77	74.00	-12.23	29.25	3	Horizontal	291	1.00	-	28.44	4.08	-
AV	2.4835G	48.95	54.00	-5.05	16.44	3	Horizontal	291	1.00	-	28.43	4.08	-

2.4-2.4835GHz_802.11ax HEW20_Nss1,(MCS0)_2TX

2462MHz_TX

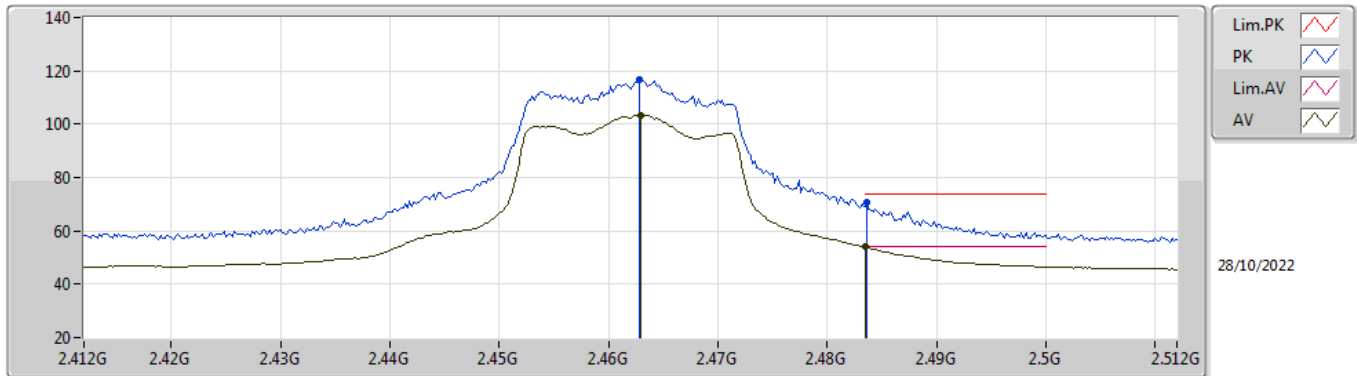

EUT_Y_2TX
 Setting 18
 03-D-J-8

Type	Freq (Hz)	Level (dBuV/m)	Limit (dBuV/m)	Margin (dB)	Raw (dBuV)	Dist (m)	Condition	Azimuth (°)	Height (m)	Comment	AF (dB)	CL (dB)	PA (dB)
PK	2.4628G	116.77	Inf	-Inf	84.36	3	Vertical	339	1.80	-	28.35	4.06	-
AV	2.463G	103.43	Inf	-Inf	71.02	3	Vertical	339	1.80	-	28.35	4.06	-
PK	2.4836G	70.67	74.00	-3.33	38.16	3	Vertical	339	1.80	-	28.43	4.08	-
AV	2.4835G	53.99	54.00	-0.01	21.48	3	Vertical	339	1.80	-	28.43	4.08	-

2.4-2.4835GHz_802.11ax HEW20_Nss1,(MCS0)_2TX

2462MHz_TX

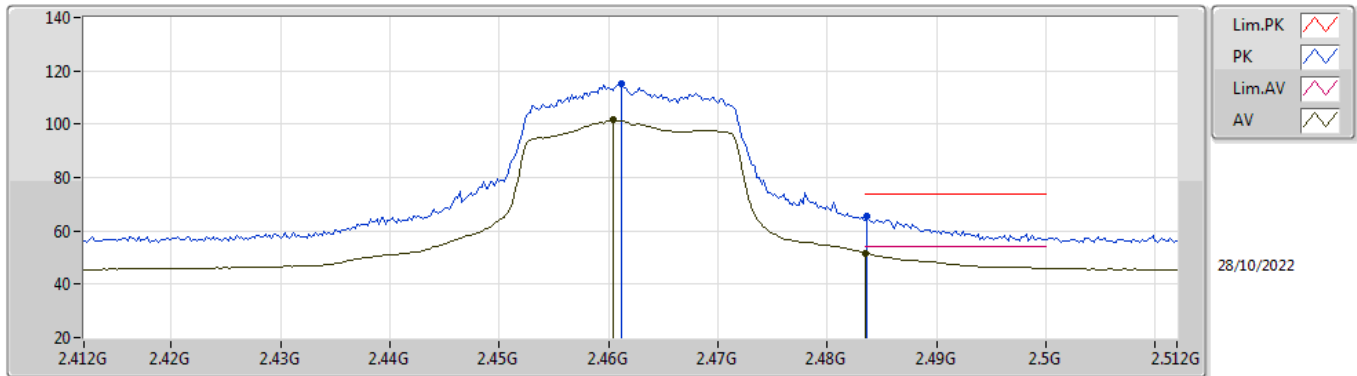

EUT_Y_2TX
 Setting 18
 03-D-J-8

Type	Freq (Hz)	Level (dBuV/m)	Limit (dBuV/m)	Margin (dB)	Raw (dBuV)	Dist (m)	Condition	Azimuth (°)	Height (m)	Comment	AF (dB)	CL (dB)	PA (dB)
PK	2.4612G	114.98	Inf	-Inf	82.58	3	Horizontal	318	1.05	-	28.34	4.06	-
AV	2.4604G	101.48	Inf	-Inf	69.08	3	Horizontal	318	1.05	-	28.34	4.06	-
PK	2.4836G	65.67	74.00	-8.33	33.16	3	Horizontal	318	1.05	-	28.43	4.08	-
AV	2.4835G	51.75	54.00	-2.25	19.24	3	Horizontal	318	1.05	-	28.43	4.08	-

2.4-2.4835GHz_802.11ax HEW20_Nss1,(MCS0)_2TX

2462MHz_TX

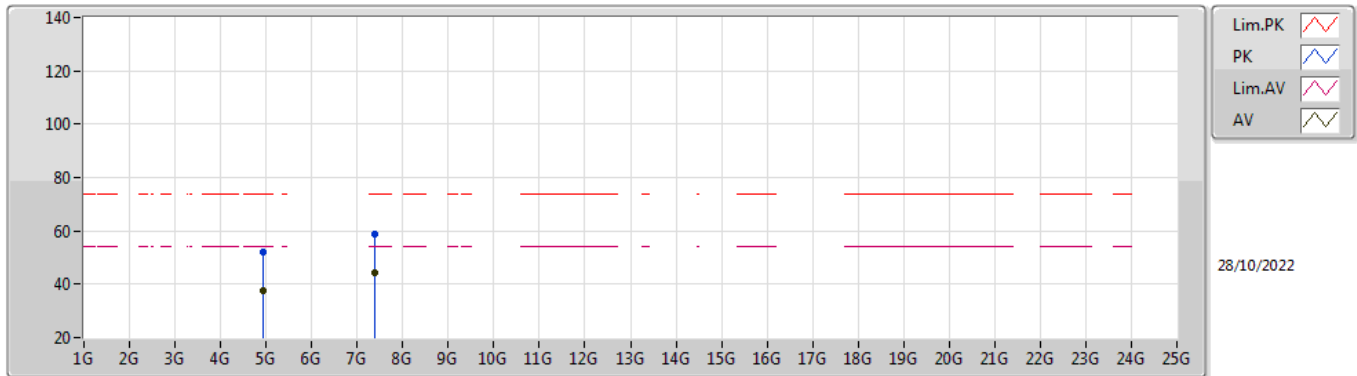

EUT X_2TX
Setting 18
03-D-J-8

Type	Freq (Hz)	Level (dBuV/m)	Limit (dBuV/m)	Margin (dB)	Raw (dBuV)	Dist (m)	Condition	Azimuth (°)	Height (m)	Comment	AF (dB)	CL (dB)	PA (dB)
PK	4.9237G	51.83	74.00	-22.17	46.41	3	Vertical	341	1.73	-	33.75	6.56	34.89
AV	4.92874G	37.34	54.00	-16.66	31.91	3	Vertical	341	1.73	-	33.76	6.56	34.89
PK	7.38516G	59.04	74.00	-14.96	48.52	3	Vertical	307	1.80	-	37.00	8.70	35.18
AV	7.38486G	44.16	54.00	-9.84	33.64	3	Vertical	307	1.80	-	37.00	8.70	35.18

2.4-2.4835GHz_802.11ax HEW20_Nss1,(MCS0)_2TX

2462MHz_TX

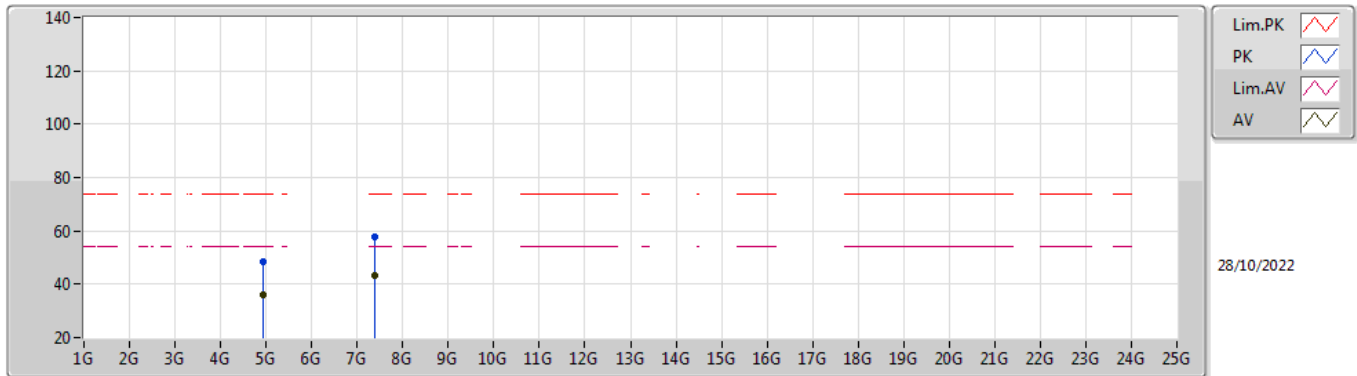

EUT X_2TX
Setting 18
03-D-J-8

Type	Freq (Hz)	Level (dBuV/m)	Limit (dBuV/m)	Margin (dB)	Raw (dBuV)	Dist (m)	Condition	Azimuth (°)	Height (m)	Comment	AF (dB)	CL (dB)	PA (dB)
PK	4.93144G	48.70	74.00	-25.30	43.26	3	Horizontal	133	1.99	-	33.76	6.57	34.89
AV	4.92406G	35.99	54.00	-18.01	30.57	3	Horizontal	133	1.99	-	33.75	6.56	34.89
PK	7.38678G	57.62	74.00	-16.38	47.10	3	Horizontal	11	1.80	-	37.00	8.70	35.18
AV	7.38714G	43.06	54.00	-10.94	32.54	3	Horizontal	11	1.80	-	37.00	8.70	35.18

2.4-2.4835GHz_802.11ax HEW40_Nss1,(MCS0)_2TX

2422MHz_TX

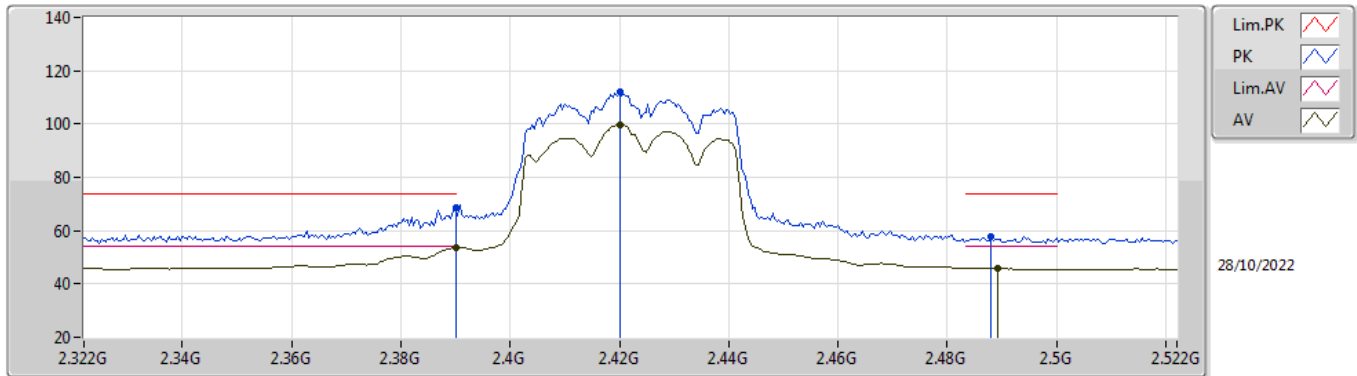

EUT Y_2TX
Setting 17
03-D-J-8

Type	Freq (Hz)	Level (dBuV/m)	Limit (dBuV/m)	Margin (dB)	Raw (dBuV)	Dist (m)	Condition	Azimuth (°)	Height (m)	Comment	AF (dB)	CL (dB)	PA (dB)
PK	2.39G	68.83	74.00	-5.17	36.58	3	Vertical	5	2.07	-	28.26	3.99	-
AV	2.39G	53.61	54.00	-0.39	21.36	3	Vertical	5	2.07	-	28.26	3.99	-
PK	2.42G	111.96	Inf	-Inf	79.64	3	Vertical	5	2.07	-	28.30	4.02	-
AV	2.42G	99.60	Inf	-Inf	67.28	3	Vertical	5	2.07	-	28.30	4.02	-
PK	2.488G	57.82	74.00	-16.18	25.28	3	Vertical	5	2.07	-	28.45	4.09	-
AV	2.4892G	45.89	54.00	-8.11	13.34	3	Vertical	5	2.07	-	28.46	4.09	-

2.4-2.4835GHz_802.11ax HEW40_Nss1,(MCS0)_2TX

2422MHz_TX

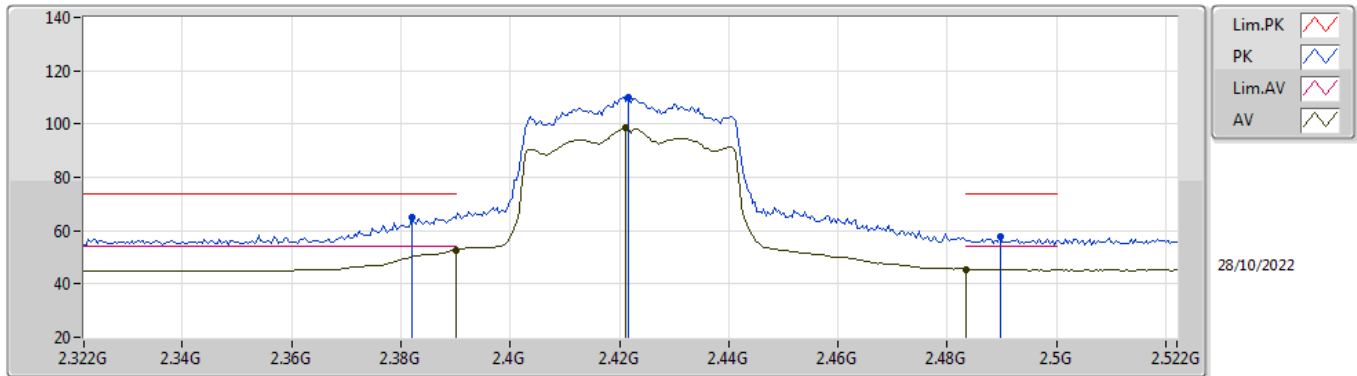

EUT Y_2TX
Setting 17
03-D-J-8

Type	Freq (Hz)	Level (dBuV/m)	Limit (dBuV/m)	Margin (dB)	Raw (dBuV)	Dist (m)	Condition	Azimuth (°)	Height (m)	Comment	AF (dB)	CL (dB)	PA (dB)
PK	2.382G	65.22	74.00	-8.78	33.01	3	Horizontal	274	1.22	-	28.23	3.98	-
AV	2.39G	52.72	54.00	-1.28	20.47	3	Horizontal	274	1.22	-	28.26	3.99	-
PK	2.4216G	110.21	Inf	-Inf	77.89	3	Horizontal	274	1.22	-	28.30	4.02	-
AV	2.4212G	98.48	Inf	-Inf	66.16	3	Horizontal	274	1.22	-	28.30	4.02	-
PK	2.4896G	57.64	74.00	-16.36	25.09	3	Horizontal	274	1.22	-	28.46	4.09	-
AV	2.4835G	45.49	54.00	-8.51	12.98	3	Horizontal	274	1.22	-	28.43	4.08	-

2.4-2.4835GHz_802.11ax HEW40_Nss1,(MCS0)_2TX

2422MHz_TX

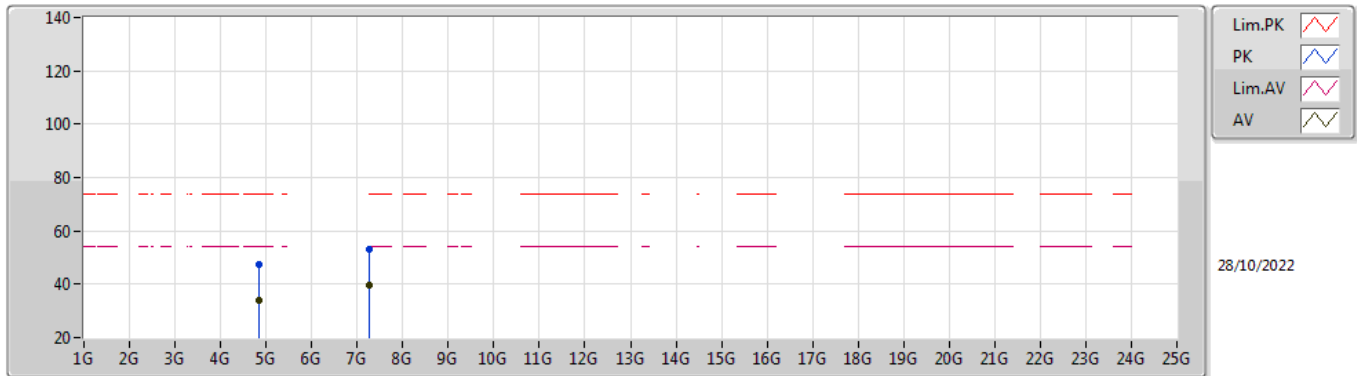

EUT_X_2TX
Setting 17
03-D-J-8

Type	Freq (Hz)	Level (dBuV/m)	Limit (dBuV/m)	Margin (dB)	Raw (dBuV)	Dist (m)	Condition	Azimuth (°)	Height (m)	Comment	AF (dB)	CL (dB)	PA (dB)
PK	4.83128G	47.65	74.00	-26.35	42.64	3	Vertical	360	1.71	-	33.39	6.52	34.90
AV	4.844G	33.72	54.00	-20.28	28.64	3	Vertical	360	1.71	-	33.46	6.52	34.90
PK	7.25646G	53.18	74.00	-20.82	42.87	3	Vertical	295	2.75	-	36.73	8.70	35.12
AV	7.2561G	39.73	54.00	-14.27	29.43	3	Vertical	295	2.75	-	36.72	8.70	35.12

2.4-2.4835GHz_802.11ax HEW40_Nss1,(MCS0)_2TX

2422MHz_TX

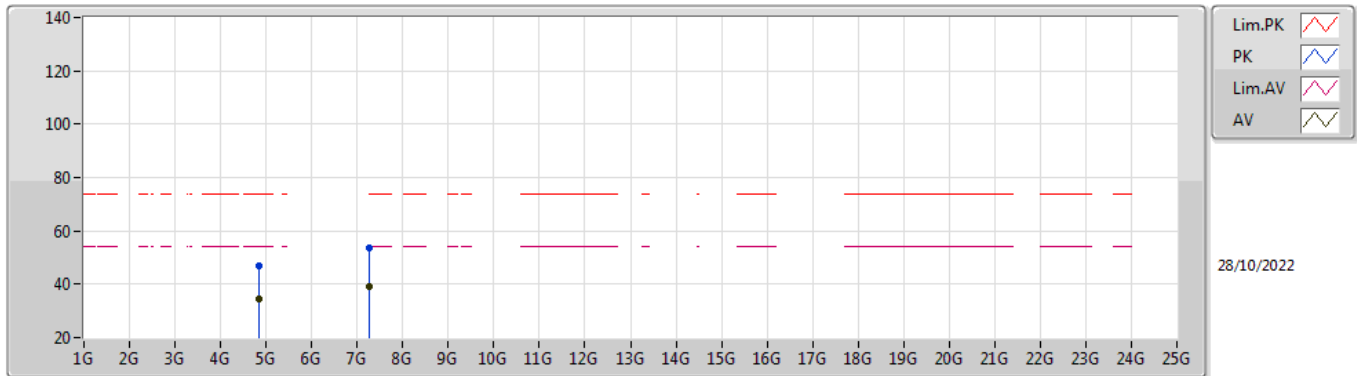

EUT_X_2TX
 Setting 17
 03-D-J-8

Type	Freq (Hz)	Level (dBuV/m)	Limit (dBuV/m)	Margin (dB)	Raw (dBuV)	Dist (m)	Condition	Azimuth (°)	Height (m)	Comment	AF (dB)	CL (dB)	PA (dB)
PK	4.84952G	46.87	74.00	-27.13	41.75	3	Horizontal	128	2.26	-	33.50	6.52	34.90
AV	4.844G	34.42	54.00	-19.58	29.34	3	Horizontal	128	2.26	-	33.46	6.52	34.90
PK	7.26852G	53.37	74.00	-20.63	43.02	3	Horizontal	14	2.68	-	36.77	8.70	35.12
AV	7.2558G	39.05	54.00	-14.95	28.75	3	Horizontal	14	2.68	-	36.72	8.70	35.12

2.4-2.4835GHz_802.11ax HEW40_Nss1,(MCS0)_2TX

2437MHz_TX

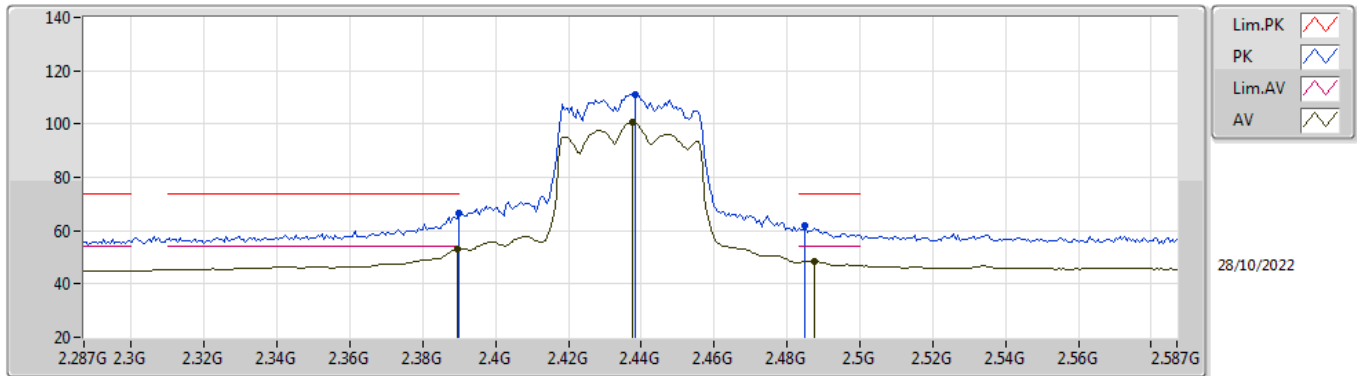

EUT Y_2TX
 Setting 17.5
 03-D-J-8

Type	Freq (Hz)	Level (dBuV/m)	Limit (dBuV/m)	Margin (dB)	Raw (dBuV)	Dist (m)	Condition	Azimuth (°)	Height (m)	Comment	AF (dB)	CL (dB)	PA (dB)
PK	2.39G	66.31	74.00	-7.69	34.06	3	Vertical	314	1.12	-	28.26	3.99	-
AV	2.3896G	53.16	54.00	-0.84	20.91	3	Vertical	314	1.12	-	28.26	3.99	-
PK	2.4382G	111.15	Inf	-Inf	78.81	3	Vertical	314	1.12	-	28.30	4.04	-
AV	2.4376G	100.74	Inf	-Inf	68.40	3	Vertical	314	1.12	-	28.30	4.04	-
PK	2.485G	61.91	74.00	-12.09	29.39	3	Vertical	314	1.12	-	28.44	4.08	-
AV	2.4874G	48.52	54.00	-5.48	15.98	3	Vertical	314	1.12	-	28.45	4.09	-

2.4-2.4835GHz_802.11ax HEW40_Nss1,(MCS0)_2TX

2437MHz_TX

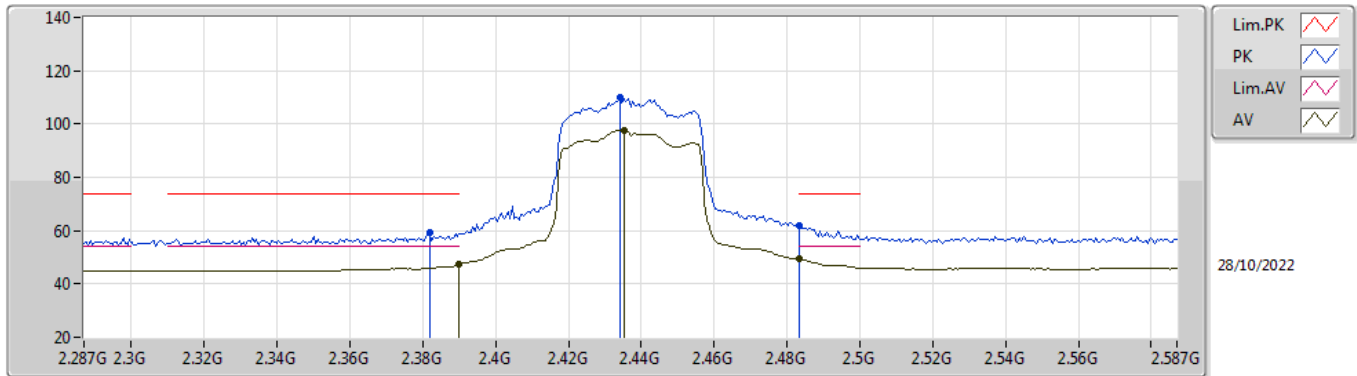

EUT Y_2TX
 Setting 17.5
 03-D-J-8

Type	Freq (Hz)	Level (dBuV/m)	Limit (dBuV/m)	Margin (dB)	Raw (dBuV)	Dist (m)	Condition	Azimuth (°)	Height (m)	Comment	AF (dB)	CL (dB)	PA (dB)
PK	2.3818G	59.09	74.00	-14.91	26.88	3	Horizontal	310	1.00	-	28.23	3.98	-
AV	2.39G	47.19	54.00	-6.81	14.94	3	Horizontal	310	1.00	-	28.26	3.99	-
PK	2.434G	109.93	Inf	-Inf	77.60	3	Horizontal	310	1.00	-	28.30	4.03	-
AV	2.4352G	97.63	Inf	-Inf	65.29	3	Horizontal	310	1.00	-	28.30	4.04	-
PK	2.4835G	61.70	74.00	-12.30	29.19	3	Horizontal	310	1.00	-	28.43	4.08	-
AV	2.4835G	49.37	54.00	-4.63	16.86	3	Horizontal	310	1.00	-	28.43	4.08	-

2.4-2.4835GHz_802.11ax HEW40_Nss1,(MCS0)_2TX

2437MHz_TX

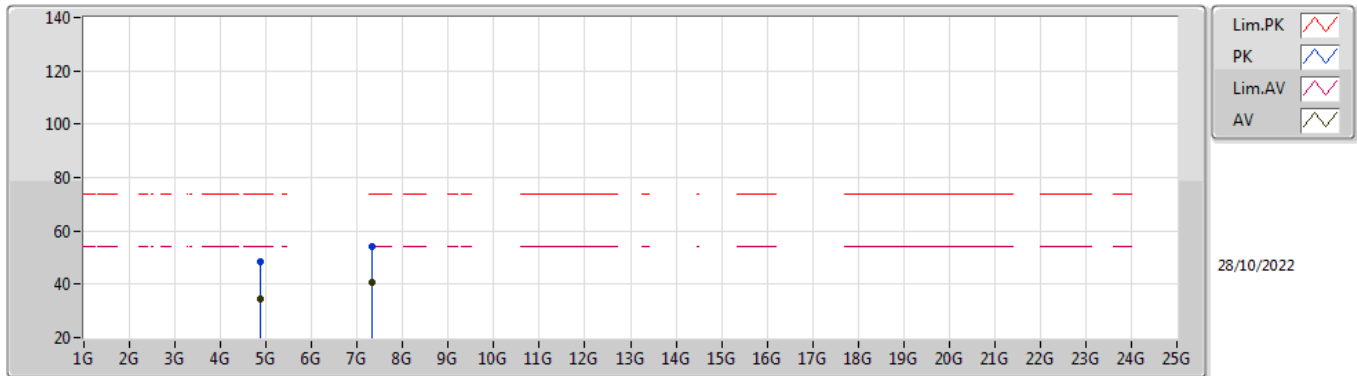

EUT_X_2TX
Setting 17.5
03-D-J-8

Type	Freq (Hz)	Level (dBuV/m)	Limit (dBuV/m)	Margin (dB)	Raw (dBuV)	Dist (m)	Condition	Azimuth (°)	Height (m)	Comment	AF (dB)	CL (dB)	PA (dB)
PK	4.8737G	48.27	74.00	-25.73	43.04	3	Vertical	344	2.06	-	33.59	6.54	34.90
AV	4.87388G	34.68	54.00	-19.32	29.44	3	Vertical	344	2.06	-	33.60	6.54	34.90
PK	7.3152G	54.13	74.00	-19.87	43.64	3	Vertical	303	1.79	-	36.93	8.70	35.14
AV	7.31604G	40.57	54.00	-13.43	30.09	3	Vertical	303	1.79	-	36.93	8.70	35.15

2.4-2.4835GHz_802.11ax HEW40_Nss1,(MCS0)_2TX

2437MHz_TX

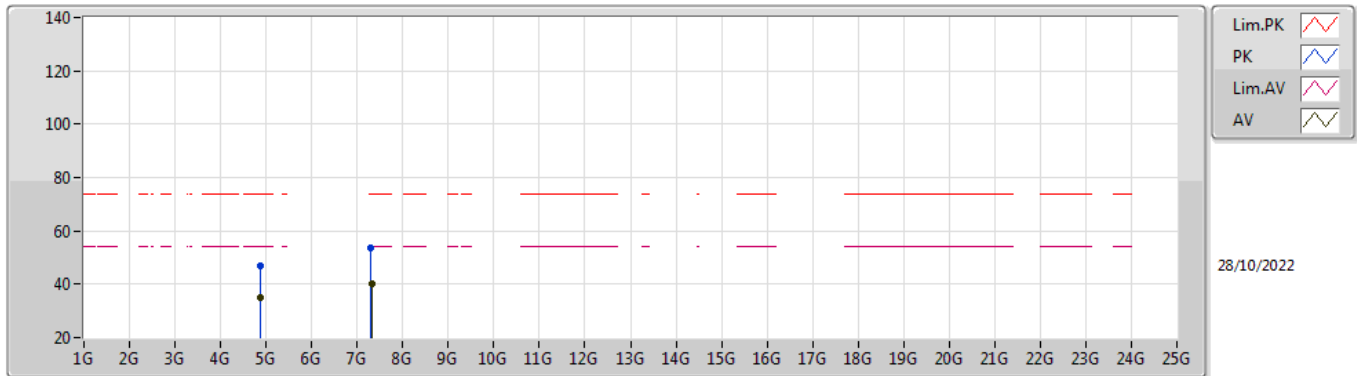

EUT_X_2TX
 Setting 17.5
 03-D-J-8

Type	Freq (Hz)	Level (dBuV/m)	Limit (dBuV/m)	Margin (dB)	Raw (dBuV)	Dist (m)	Condition	Azimuth (°)	Height (m)	Comment	AF (dB)	CL (dB)	PA (dB)
PK	4.87436G	46.97	74.00	-27.03	41.73	3	Horizontal	130	2.03	-	33.60	6.54	34.90
AV	4.874G	35.08	54.00	-18.92	29.84	3	Horizontal	130	2.03	-	33.60	6.54	34.90
PK	7.30932G	53.80	74.00	-20.20	43.32	3	Horizontal	12	2.73	-	36.92	8.70	35.14
AV	7.31436G	40.29	54.00	-13.71	29.80	3	Horizontal	12	2.73	-	36.93	8.70	35.14

2.4-2.4835GHz_802.11ax HEW40_Nss1,(MCS0)_2TX

2452MHz_TX

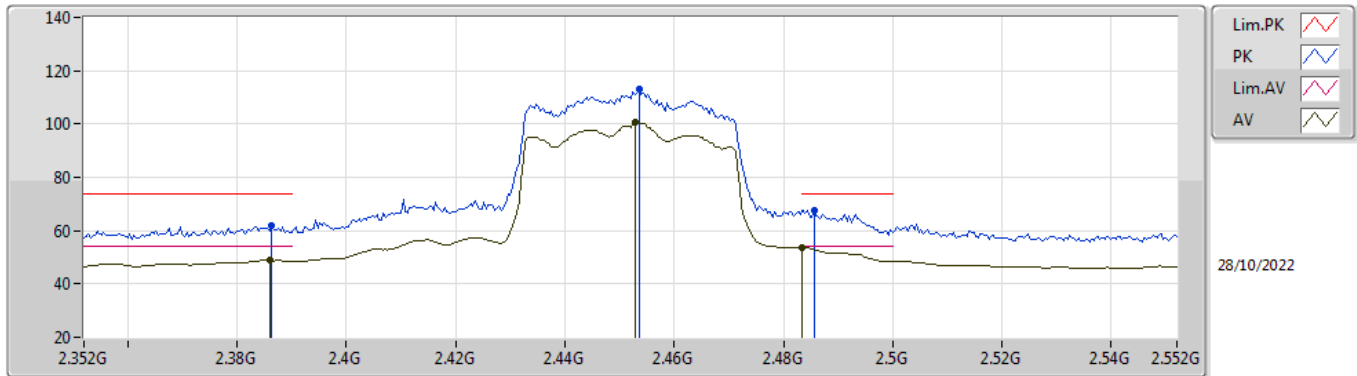

EUT Y_2TX
Setting 17
03-D-J-8

Type	Freq (Hz)	Level (dBuV/m)	Limit (dBuV/m)	Margin (dB)	Raw (dBuV)	Dist (m)	Condition	Azimuth (°)	Height (m)	Comment	AF (dB)	CL (dB)	PA (dB)
PK	2.3864G	61.66	74.00	-12.34	29.42	3	Vertical	309	1.71	-	28.25	3.99	-
AV	2.386G	48.91	54.00	-5.09	16.68	3	Vertical	309	1.71	-	28.24	3.99	-
PK	2.4536G	113.35	Inf	-Inf	80.99	3	Vertical	309	1.71	-	28.31	4.05	-
AV	2.4528G	100.65	Inf	-Inf	68.29	3	Vertical	309	1.71	-	28.31	4.05	-
PK	2.4856G	67.70	74.00	-6.30	35.17	3	Vertical	309	1.71	-	28.44	4.09	-
AV	2.4835G	53.66	54.00	-0.34	21.15	3	Vertical	309	1.71	-	28.43	4.08	-

2.4-2.4835GHz_802.11ax HEW40_Nss1,(MCS0)_2TX

2452MHz_TX

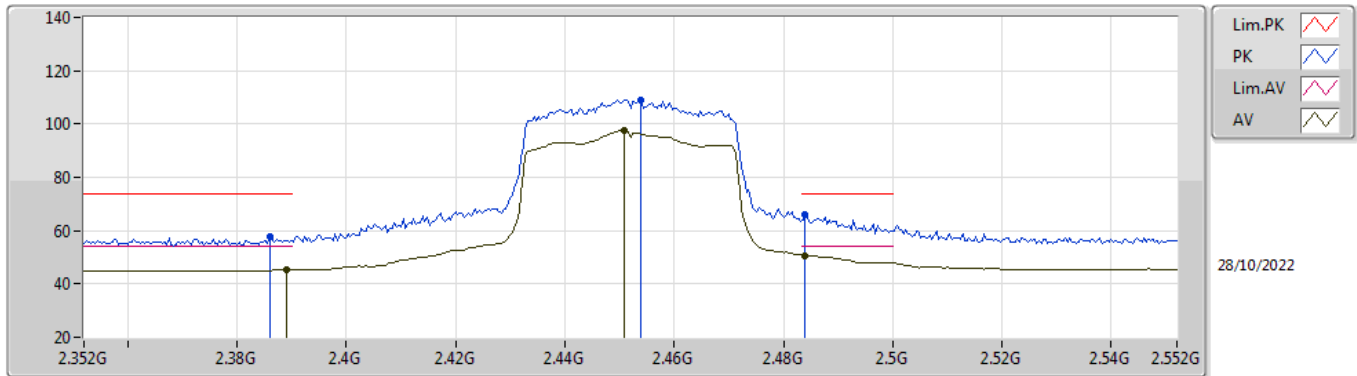

EUT Y_2TX
Setting 17
03-D-J-8

Type	Freq (Hz)	Level (dBuV/m)	Limit (dBuV/m)	Margin (dB)	Raw (dBuV)	Dist (m)	Condition	Azimuth (°)	Height (m)	Comment	AF (dB)	CL (dB)	PA (dB)
PK	2.386G	57.96	74.00	-16.04	25.73	3	Horizontal	306	1.15	-	28.24	3.99	-
AV	2.3892G	45.31	54.00	-8.69	13.06	3	Horizontal	306	1.15	-	28.26	3.99	-
PK	2.454G	109.01	Inf	-Inf	76.64	3	Horizontal	306	1.15	-	28.32	4.05	-
AV	2.4508G	97.56	Inf	-Inf	65.21	3	Horizontal	306	1.15	-	28.30	4.05	-
PK	2.484G	66.22	74.00	-7.78	33.70	3	Horizontal	306	1.15	-	28.44	4.08	-
AV	2.484G	50.70	54.00	-3.30	18.18	3	Horizontal	306	1.15	-	28.44	4.08	-

2.4-2.4835GHz_802.11ax HEW40_Nss1,(MCS0)_2TX

2452MHz_TX

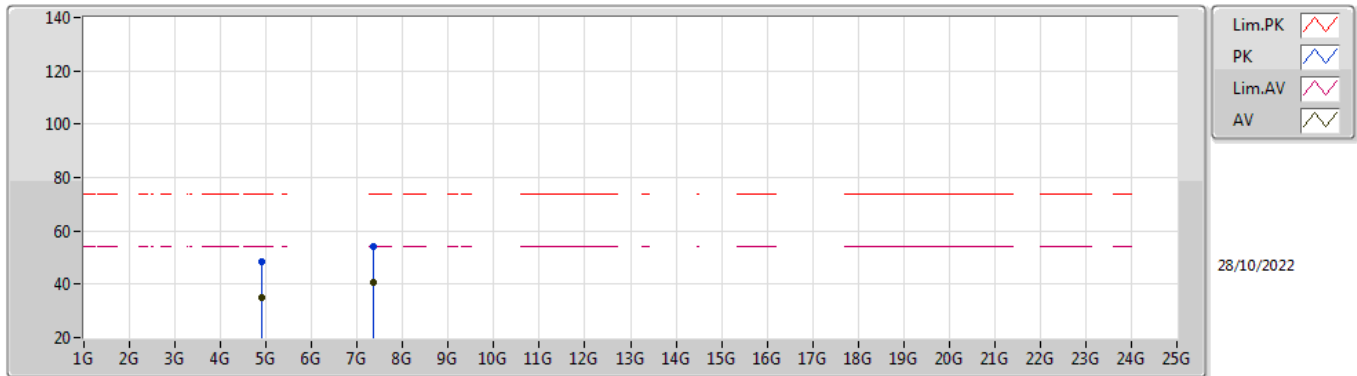

EUT_X_2TX
Setting 17
03-D-J-8

Type	Freq (Hz)	Level (dBuV/m)	Limit (dBuV/m)	Margin (dB)	Raw (dBuV)	Dist (m)	Condition	Azimuth (°)	Height (m)	Comment	AF (dB)	CL (dB)	PA (dB)
PK	4.90202G	48.67	74.00	-25.33	43.31	3	Vertical	334	2.01	-	33.70	6.55	34.89
AV	4.904G	35.24	54.00	-18.76	29.87	3	Vertical	334	2.01	-	33.71	6.55	34.89
PK	7.3656G	54.08	74.00	-19.92	43.55	3	Vertical	332	1.80	-	37.00	8.70	35.17
AV	7.3653G	40.47	54.00	-13.53	29.94	3	Vertical	332	1.80	-	37.00	8.70	35.17

2.4-2.4835GHz_802.11ax HEW40_Nss1,(MCS0)_2TX

2452MHz_TX

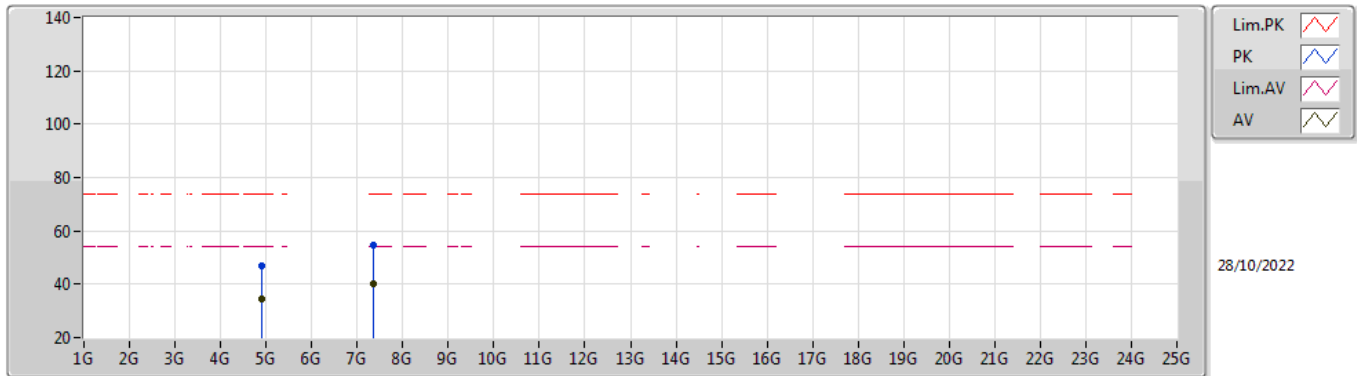

EUT_X_2TX
Setting 17
03-D-J-8

Type	Freq (Hz)	Level (dBuV/m)	Limit (dBuV/m)	Margin (dB)	Raw (dBuV)	Dist (m)	Condition	Azimuth (°)	Height (m)	Comment	AF (dB)	CL (dB)	PA (dB)
PK	4.89404G	47.05	74.00	-26.95	41.71	3	Horizontal	133	2.28	-	33.68	6.55	34.89
AV	4.904G	34.70	54.00	-19.30	29.33	3	Horizontal	133	2.28	-	33.71	6.55	34.89
PK	7.34736G	54.79	74.00	-19.21	44.26	3	Horizontal	17	2.04	-	36.99	8.70	35.16
AV	7.3659G	40.24	54.00	-13.76	29.71	3	Horizontal	17	2.04	-	37.00	8.70	35.17