



## Welcome to MetroLinq™



Interference-Free Gigabit Wireless

# Unboxing

After opening the box, you will find...

- MetroLing™
- Bracket Kit
- PoE Power Supply
- Power Cable

## Tools/Items Required

- 13 mm Socket Wrench
- Flat-Head Screwdriver
- Ethernet Cables
- (Optional) Alignment Scope ICC-SCOPE-9x50

For helpful training and user-case information, please go to [ignitenet.com/support](https://www.ignitenet.com/support)

# Assembly

The MetroLinq™ bracket is designed for wall and pole mounting (25 mm - 80 mm pole diameter). Choose what is best for your location and select hardware accordingly.

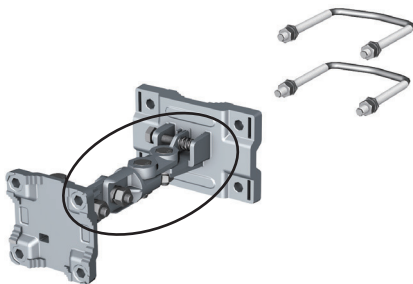

1. Ensure all four position-locking bolts are tight before installing.

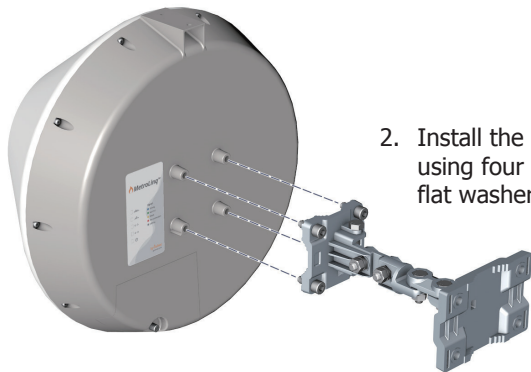

2. Install the bracket onto MetroLinq™ using four M8 bolts, lock washers, and flat washers.

# Power Up

1. Connect an Ethernet cable from the MetroLing™ ETH0/PoE IN port (right-side RJ-45) to the PoE port on the power supply.



2. Connect Ethernet cable from the "LAN" port on the power supply to your LAN device.
3. Connect the power cord to a nearby AC power source.



# Alignment

IgniteNet strongly recommends using the ICC-SCOPE-9x50 Alignment Scope for alignment. To install, place the scope on top of the MetroLinq™ housing and secure it with its thumb screw.

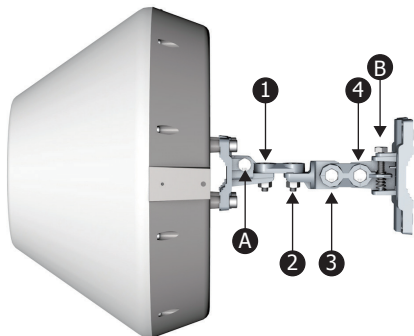
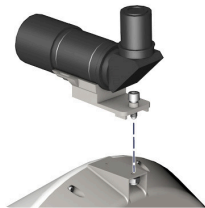

! Note: Do not adjust bolts A and B without first loosening 1 and 4 respectively.

1. Loosen coarse adjustment bolts 2 and 3 and set initial alignment. Don't worry, you don't have to be too accurate yet. After you have set the coarse alignment, tighten bolts 2 and 3.
2. Loosen the horizontal fine-tune adjustment bolt 4. Use fine-tune bolt "B" to optimize the horizontal position. Re-tighten bolt 4.
3. Loosen the vertical fine-tune adjustment bolt 1. Use fine-tune bolt "A" to optimize the vertical position. Re-tighten bolt 1.
4. Initial alignment should be based on optical or visual alignment. After you achieve this, repeat steps 2 and 3 while watching the 60 GHz signal strength LED. Optimize position to the LED indicator.
5. Ensure all bolts are fully tightened, remove the alignment scope (if installed), and enjoy Gigabit interference-free wireless.

# Software

1. To configure your MetroLinq, connect your computer to the device through the LAN port of the power supply or directly to the ETH1 port on the device. The default IP mode is DHCP client, so if the device obtains an address from a DHCP server on the network, then use that IP (you can use the Discovery Tool from the IgniteNet support site to find the DHCP address). If the device does not obtain a DHCP address, it reverts to the fallback IP of 192.168.1.20 and you can access it on that IP. Direct your web browser to the correct IP and log in.
2. After you have logged in, follow the steps in the Setup Wizard to configure the device for your network.

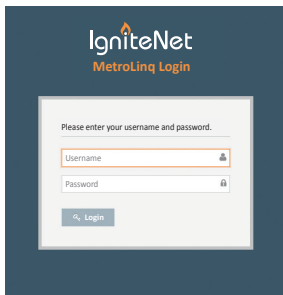

username: root  
password: admin123

For more configuration details and training,  
please go to [ignitenet.com/support](https://ignitenet.com/support)

150200001244A R04

## **FCC Statement:**

### **Federal Communication Commission Interference Statement**

This equipment has been tested and found to comply with the limits for a Class B digital device, pursuant to Part 15 of the FCC Rules. These limits are designed to provide reasonable protection against harmful interference in a residential installation. This equipment generates, uses and can radiate radio frequency energy and, if not installed and used in accordance with the instructions, may cause harmful interference to radio communications. However, there is no guarantee that interference will not occur in a particular installation. If this equipment does cause harmful interference to radio or television reception, which can be determined by turning the equipment off and on, the user is encouraged to try to correct the interference by one of the following measures:

- Reorient or relocate the receiving antenna.
- Increase the separation between the equipment and receiver.
- Connect the equipment into an outlet on a circuit different from that to which the receiver is connected.
- Consult the dealer or an experienced radio/TV technician for help.

FCC Caution: Any changes or modifications not expressly approved by the party responsible for compliance could void the user's authority to operate this equipment.

This device complies with Part 15 of the FCC Rules. Operation is subject to the following two conditions: (1) This device may not cause harmful interference, and (2) this device must accept any interference received, including interference that may cause undesired operation.

This device and its antennas(s) must not be co-located or operating in conjunction with any other antenna or transmitter except in accordance with FCC multi-transmitter product procedures.

### **IMPORTANT NOTE:**

#### **FCC Radiation Exposure Statement:**

This equipment complies with FCC radiation exposure limits set forth for an uncontrolled environment. This equipment should be installed and operated with minimum distance 56 cm between the radiator & your body.

**Professional installation instruction:****1. Installation personal**

This product is designed for specific application and needs to be installed by a qualified personal who has RF and related rule knowledge. The general user shall not attempt to install or change the setting.

**2. Installation location**

The product shall be installed at a location where the radiating antenna can be kept 56 cm from nearby person in normal operation condition to meet regulatory RF exposure requirement.

**3. External antenna**

Use only the antennas which have been approved by the applicant. The non-approved antenna(s) may produce unwanted spurious or excessive RF transmitting power which may lead to the violation of FCC limit and is prohibited.

**4. Installation procedure**

Please refer to user's manual for the detail.

**5. Warning**

Please carefully select the installation position and make sure that the final output power does not exceed the limit set force in relevant rules. The violation of the rule could lead to serious federal penalty.



## IC Statement:

This device complies with Industry Canada license-exempt RSS standard(s). Operation is subject to the following two conditions: (1) this device may not cause interference, and (2) this device must accept any interference, including interference that may cause undesired operation of the device.

*Le présent appareil est conforme aux CNR d'Industrie Canada applicables aux appareils radio exempts de licence.*

*L'exploitation est autorisée aux deux conditions suivantes : (1) l'appareil ne doit pas produire de brouillage, et (2) l'utilisateur de l'appareil doit accepter tout brouillage radioélectrique subi, même si le brouillage est susceptible d'en compromettre le fonctionnement.*

This device and its antenna(s) must not be co-located or operating in conjunction with any other antenna or transmitter except in accordance with IC multi-transmitter product procedures.

*Cet appareil et son antenne (s) ne doit pas être co-localisés ou fonctionner en association avec une autre antenne ou transmetteur.*

This radio transmitter (IC: 3857A-ML6035G3) has been approved by Industry Canada to operate with the antenna types listed below with the maximum permissible gain indicated. Antenna types not included in this list, having a gain greater than the maximum gain indicated for that type, are strictly prohibited for use with this device.

*Le présent émetteur radio (IC: 3857A-ML6035G3) a été approuvé par Industrie Canada pour fonctionner avec les types d'antenne énumérés ci-dessous et ayant un gain admissible maximal d'antenne. Les types d'antenne non inclus dans cette liste, ou dont le gain est supérieur au gain maximal indiqué, sont strictement interdits pour l'exploitation de l'émetteur.*

### Antenna list:

Ant.	Brand	P/N	Antenna Type	Connector	Gain (dBi)	
					Band 1	Band 4
1	Accton	120G00000156A	Dish Ant.	N/A	9.7	12.4

Note: Ant. 1 & Ant. 2 are the same type antennas, only the higher gain antenna "Ant. 1" was tested.

Dynamic Frequency Selection (DFS) for devices operating in the bands 5250- 5350 MHz, 5470-5600 MHz and 5650-5725 MHz.

*Sélection dynamique de fréquences (DFS) pour les dispositifs fonctionnant dans les bandes 5250-5350 MHz, 5470-5600 MHz et 5650-5725 MHz.*

The maximum antenna gain permitted for devices in the bands 5250-5350 MHz and 5470-5725 MHz shall be such that the equipment still complies with the e.i.r.p. limit.

*le gain maximal d'antenne permis pour les dispositifs utilisant les bandes 5250-5350 MHz et 5470-5725 MHz doit se conformer à la limite de p.i.r.e.*

The maximum antenna gain permitted for devices in the band 5725-5850 MHz shall be such that the equipment still complies with the e.i.r.p. limits specified for point-to-point and non-point-to-point operation as appropriate.

*le gain maximal d'antenne permis (pour les dispositifs utilisant la bande 5725-5850 MHz)*

*doit se conformer à la limite de p.i.r.e. spécifiée pour l'exploitation point à point et non point à point, selon le cas.*

Users should also be advised that high-power radars are allocated as primary users (i.e. priority users) of the bands 5250-5350 MHz and 5650-5850 MHz and that these radars could cause interference and/or damage to LE-LAN devices.

*De plus, les utilisateurs devraient aussi être avisés que les utilisateurs de radars de haute puissance sont désignés utilisateurs principaux (c.-à-d., qu'ils ont la priorité) pour les bandes 5250-5350 MHz et 5650-5850 MHz et que ces radars pourraient causer du brouillage et/ou des dommages aux dispositifs LAN-EL.*

#### **IMPORTANT NOTE:**

##### **IC Radiation Exposure Statement:**

This equipment complies with IC RSS-102 radiation exposure limits set forth for an uncontrolled environment. This equipment should be installed and operated with minimum distance 56 cm between the radiator & your body.

*Cet équipement est conforme aux limites d'exposition aux rayonnements IC établies pour un environnement non contrôlé.*

*Cet équipement doit être installé et utilisé avec un minimum de 56 cm de distance entre la source de rayonnement et votre corps.*