

FCC Test Report

Report No.: RF121012C11A

FCC ID: HDCWLAN193XF1

Test Model: BSAP-1930, BSAP-1935

Received Date: Aug. 14, 2015

Test Date: Aug. 21 ~ Sep. 08, 2015

Issued Date: Sep. 18, 2015

Applicant: Adtran

Address: 901 Explorer Boulevard, Huntsville Alabama, United States, 35806-2807

Issued By: Bureau Veritas Consumer Products Services (H.K.) Ltd., Taoyuan Branch

Lab Address: No. 47-2, 14th Ling, Chia Pau Vil., Lin Kou Dist., New Taipei City, Taiwan, R.O.C.

Test Location: No. 19, Hwa Ya 2nd Rd., Wen Hwa Vil., Kwei Shan Dist., Taoyuan City 33383, TAIWAN (R.O.C.)



This report is for your exclusive use. Any copying or replication of this report to or for any other person or entity, or use of our name or trademark, is permitted only with our prior written permission. This report sets forth our findings solely with respect to the test samples identified herein. The results set forth in this report are not indicative or representative of the quality or characteristics of the lot from which a test sample was taken or any similar or identical product unless specifically and expressly noted. Our report includes all of the tests requested by you and the results thereof based upon the information that you provided to us. You have 60 days from date of issuance of this report to notify us of any material error or omission caused by our negligence, provided, however, that such notice shall be in writing and shall specifically address the issue you wish to raise. A failure to raise such issue within the prescribed time shall constitute your unqualified acceptance of the completeness of this report, the tests conducted and the correctness of the report contents. Unless specific mention, the uncertainty of measurement has been explicitly taken into account to declare the compliance or non-compliance to the specification. The report must not be used by the client to claim product certification, approval, or endorsement by TAF or any government agencies.



Table of Contents

Release Control Record	4
1 Certificate of Conformity	5
2 Summary of Test Results	6
2.1 Measurement Uncertainty.....	6
2.2 Modification Record.....	6
3 General Information	7
3.1 General Description of EUT.....	7
3.2 Description of Test Modes.....	8
3.2.1 Test Mode Applicability and Tested Channel Detail.....	9
3.3 Duty Cycle of Test Signal.....	12
3.4 Description of Support Units.....	13
3.4.1 Configuration of System under Test.....	13
3.5 General Description of Applied Standards.....	14
4 Test Types and Results	15
4.1 Radiated Emission and Bandedge Measurement.....	15
4.1.1 Limits of Radiated Emission and Bandedge Measurement.....	15
4.1.2 Test Instruments.....	16
4.1.3 Test Procedures.....	17
4.1.4 Deviation from Test Standard.....	17
4.1.5 Test Set Up.....	18
4.1.6 EUT Operating Conditions.....	18
4.1.7 Test Results.....	19
4.2 Conducted Emission Measurement.....	65
4.2.1 Limits of Conducted Emission Measurement.....	65
4.2.2 Test Instruments.....	65
4.2.3 Test Procedures.....	66
4.2.4 Deviation from Test Standard.....	66
4.2.5 Test Setup.....	66
4.2.6 EUT Operating Conditions.....	66
4.2.7 Test Results.....	67
4.3 Transmit Power Measurement.....	71
4.3.1 Limits of Transmit Power Measurement.....	71
4.3.2 Test Setup.....	71
4.3.3 Test Instruments.....	71
4.3.4 Test Procedure.....	72
4.3.5 Deviation from Test Standard.....	72
4.3.6 EUT Operating Conditions.....	72
4.3.7 Test Result.....	73
4.4 Peak Power Spectral Density Measurement.....	81
4.4.1 Limits of Peak Power Spectral Density Measurement.....	81
4.4.2 Test Setup.....	81
4.4.3 Test Instruments.....	81
4.4.4 Test Procedures.....	82
4.4.5 Deviation from Test Standard.....	82
4.4.6 EUT Operating Conditions.....	82
4.4.7 Test Results.....	83
4.5 Frequency Stability.....	89
4.5.1 Limits of Frequency Stability Measurement.....	89
4.5.2 Test Setup.....	89
4.5.3 Test Instruments.....	89
4.5.4 Test Procedure.....	89
4.5.5 Deviation from Test Standard.....	89
4.5.6 EUT Operating Condition.....	89



4.5.7 Test Results	90
4.6 6dB Bandwidth Measurement	92
4.6.1 Limits of 6dB Bandwidth Measurement	92
4.6.2 Test Setup	92
4.6.3 Test Instruments	92
4.6.4 Test Procedure	92
4.6.5 Deviation from Test Standard	92
4.6.6 EUT Operating Condition	92
4.6.7 Test Results	93
5 Pictures of Test Arrangements	96
Appendix – Information on the Testing Laboratories	97



A D T

Release Control Record

Issue No.	Description	Date Issued
RF121012C11A	Original release	Sep. 18, 2015

1 Certificate of Conformity

Product: Wireless 802.11 abgn AP

Brand: Adtran

Test Model: BSAP-1930, BSAP-1935

Sample Status: ENGINEERING SAMPLE

Applicant: Adtran

Test Date: Aug. 21 ~ Sep. 08, 2015

Standards: 47 CFR FCC Part 15, Subpart E (Section 15.407)
ANSI C63.10:2013

The above equipment has been tested by **Bureau Veritas Consumer Products Services (H.K.) Ltd., Taoyuan Branch**, and found compliance with the requirement of the above standards. The test record, data evaluation & Equipment Under Test (EUT) configurations represented herein are true and accurate accounts of the measurements of the sample's EMC characteristics under the conditions specified in this report.

Prepared by : Ivy Lin , **Date:** Sep. 18, 2015
Ivy Lin / Specialist

Approved by : Ken Liu , **Date:** Sep. 18, 2015
Ken Liu / Senior Manager

2 Summary of Test Results

47 CFR FCC Part 15, Subpart E (SECTION 15.407)			
FCC Clause	Test Item	Result	Remarks
15.407(b)(6)	AC Power Conducted Emissions	Pass	Meet the requirement of limit. Minimum passing margin is -19.42dB at 0.15391MHz.
15.407(b) (1/2/3/4/6)	Radiated Emissions & Band Edge Measurement	Pass	Meet the requirement of limit. Minimum passing margin is -1.0dB at 5714.90MHz, 300.16MHz.
15.407(a)(1/2 /3)	Max Average Transmit Power	Pass	Meet the requirement of limit.
15.407(a)(1/2 /3)	Peak Power Spectral Density	Pass	Meet the requirement of limit.
15.407(e)	6dB bandwidth	Pass	Meet the requirement of limit. (U-NII-3 Band only)
15.407(g)	Frequency Stability	Pass	Meet the requirement of limit.
15.203	Antenna Requirement	Pass	PIFA antenna: Antenna connector is IPEX not a standard connector. Dipole antenna: Antenna connector is RSMA not a standard connector.

2.1 Measurement Uncertainty

Where relevant, the following measurement uncertainty levels have been estimated for tests performed on the EUT as specified in CISPR 16-4-2:

Measurement	Frequency	Expanded Uncertainty (k=2) (
-------------	-----------	------------------------------

3 General Information

3.1 General Description of EUT

Product	Wireless 802.11 abgn AP
Brand	Adtran
Test Model	BSAP-1930, BSAP-1935
Status of EUT	ENGINEERING SAMPLE
Power Supply Rating	5Vdc (host)
Modulation Type	64QAM, 16QAM, QPSK, BPSK
Modulation Technology	OFDM
Transfer Rate	802.11a: 54.0/ 48.0/ 36.0/ 24.0/ 18.0/ 12.0/ 9.0/ 6.0Mbps 802.11n: up to 450.0Mbps
Operating Frequency	5180 ~ 5240MHz, 5745 ~ 5825MHz
Number of Channel	5180 ~ 5240MHz: 4 for 802.11a, 802.11n (HT20) 2 for 802.11n (HT40) 5745 ~ 5825MHz: 5 for 802.11a, 802.11n (HT20) 2 for 802.11n (HT40)
Output Power	3TX: 5180 ~ 5240MHz: 222.977mW 5745 ~ 5825MHz: 136.270mW 1TX: 5180 ~ 5240MHz: 53.951mW 5745 ~ 5825MHz: 73.114mW
Antenna Type	Refer to Note
Antenna Connector	Refer to Note
Accessory Device	NA
Data Cable Supplied	NA

Note:

1. This report is prepared for FCC class II permissive change. The difference compared with the original design is updating standard to new rule version. All test data had been re-tested.
2. The following models are provided to this EUT.

Brand	Model	Description
Adtran	BSAP-1930	Internal antenna
	BSAP-1935	External antenna

3. The EUT incorporates a MIMO function. Physically, the EUT provides 3 completed transmitters and 3 receivers.

Modulation Mode	TX Function
802.11a	1TX/ 3TX
802.11n (HT20)	3TX
802.11n (HT40)	3TX

4. The following antenna types are provided to the EUT.

Antenna type	Antenna connector	Antenna Gain (dBi)	
		2.4GHz	5GHz
PIFA	IPEX	5	6
Dipole	RSMA	3	3

3.2 Description of Test Modes

FOR 5180 ~ 5240MHz

4 channels are provided for 802.11a, 802.11n (HT20):

Channel	Frequency	Channel	Frequency
36	5180 MHz	44	5220 MHz
40	5200 MHz	48	5240 MHz

2 channels are provided for 802.11n (HT40):

Channel	Frequency	Channel	Frequency
38	5190 MHz	46	5230 MHz

FOR 5745 ~ 5825MHz

5 channels are provided for 802.11a, 802.11n (HT20):

Channel	Frequency	Channel	Frequency
149	5745MHz	161	5805MHz
153	5765MHz	165	5825MHz
157	5785MHz		

2 channels are provided for 802.11n (HT40):

Channel	Frequency	Channel	Frequency
151	5755MHz	159	5795MHz

3.2.1 Test Mode Applicability and Tested Channel Detail

EUT CONFIGURE MODE	APPLICABLE TO				DESCRIPTION
	RE \geq 1G	RE $<$ 1G	PLC	APCM	
A1	√	√	√	√	PIFA antenna: 3TX
A2	√	-	-	√	PIFA antenna: 1TX
B1	√	√	√	-	Dipole antenna: 3TX
B2	√	-	-	-	Dipole antenna: 1TX

Where **RE \geq 1G**: Radiated Emission above 1GHz & Bandedge Measurement
RE $<$ 1G: Radiated Emission below 1GHz
PLC: Power Line Conducted Emission
APCM: Antenna Port Conducted Measurement

NOTE: The EUT had been pre-tested on the positioned of each 3 axis. The worst case was found when positioned on **X-plane**.

Radiated Emission Test (Above 1GHz):

- Pre-Scan has been conducted to determine the worst-case mode from all possible combinations between available modulations, data rates and antenna ports (if EUT with antenna diversity architecture).
- Following channel(s) was (were) selected for the final test as listed below.

EUT CONFIGURE MODE	MODE	FREQ. BAND (MHz)	AVAILABLE CHANNEL	TESTED CHANNEL	MODULATION TECHNOLOGY	MODULATION TYPE	DATA RATE (Mbps)	Antenna & TX function
A1	802.11a	5180-5240	36 to 48	36, 40, 48	OFDM	BPSK	6.0	PIFA antenna, 3TX
	802.11n (HT20)		36 to 48	36, 40, 48	OFDM	BPSK	7.2	
	802.11n (HT40)		38 to 46	38, 46	OFDM	BPSK	15.0	
	802.11a	5745-5825	149 to 165	149, 157, 165	OFDM	BPSK	6.0	
	802.11n (HT20)		149 to 165	149, 157, 165	OFDM	BPSK	7.2	
	802.11n (HT40)		151 to 159	151, 159	OFDM	BPSK	15.0	
A2	802.11a	5180-5240	36 to 48	36, 40, 48	OFDM	BPSK	6.0	PIFA antenna, 1TX
	802.11a	5745-5825	149 to 165	149, 157, 165	OFDM	BPSK	6.0	
B1	802.11a	5180-5240	36 to 48	36, 40, 48	OFDM	BPSK	6.0	Dipole antenna, 3TX
	802.11n (HT20)		36 to 48	36, 40, 48	OFDM	BPSK	7.2	
	802.11n (HT40)		38 to 46	38, 46	OFDM	BPSK	15.0	
	802.11a	5745-5825	149 to 165	149, 157, 165	OFDM	BPSK	6.0	
	802.11n (HT20)		149 to 165	149, 157, 165	OFDM	BPSK	7.2	
	802.11n (HT40)		151 to 159	151, 159	OFDM	BPSK	15.0	
B2	802.11a	5180-5240	36 to 48	36, 40, 48	OFDM	BPSK	6.0	Dipole antenna, 1TX
	802.11a	5745-5825	149 to 165	149, 157, 165	OFDM	BPSK	6.0	

Radiated Emission Test (Below 1GHz):

- Pre-Scan has been conducted to determine the worst-case mode from all possible combinations between available modulations, data rates and antenna ports (if EUT with antenna diversity architecture).
- Following channel(s) was (were) selected for the final test as listed below.

EUT CONFIGURE MODE	MODE	FREQ. BAND (MHz)	AVAILABLE CHANNEL	TESTED CHANNEL	MODULATION TECHNOLOGY	MODULATION TYPE	DATA RATE (Mbps)	Antenna & TX function
A1	802.11a	5180-5240, 5745-5825	36 to 48, 149 to 165	40	OFDM	BPSK	6.0	PIFA antenna, 3TX
B1	802.11a	5180-5240, 5745-5825	36 to 48, 149 to 165	40	OFDM	BPSK	6.0	Dipole antenna, 3TX

Power Line Conducted Emission Test:

- Pre-Scan has been conducted to determine the worst-case mode from all possible combinations between available modulations, data rates and antenna ports (if EUT with antenna diversity architecture).
- Following channel(s) was (were) selected for the final test as listed below.

EUT CONFIGURE MODE	MODE	FREQ. BAND (MHz)	AVAILABLE CHANNEL	TESTED CHANNEL	MODULATION TECHNOLOGY	MODULATION TYPE	DATA RATE (Mbps)	Antenna & TX function
A1	802.11a	5180-5240, 5745-5825	36 to 48, 149 to 165	40	OFDM	BPSK	6.0	PIFA antenna, 3TX
B1	802.11a	5180-5240, 5745-5825	36 to 48, 149 to 165	40	OFDM	BPSK	6.0	Dipole antenna, 3TX

Antenna Port Conducted Measurement:

- This item includes all test value of each mode, but only includes spectrum plot of worst value of each mode.
- Pre-Scan has been conducted to determine the worst-case mode from all possible combinations between available modulations, data rates and antenna ports (if EUT with antenna diversity architecture).
- Following channel(s) was (were) selected for the final test as listed below.

EUT CONFIGURE MODE	MODE	FREQ. BAND (MHz)	AVAILABLE CHANNEL	TESTED CHANNEL	MODULATION TECHNOLOGY	MODULATION TYPE	DATA RATE (Mbps)	Antenna & TX function
A1	802.11a	5180-5240	36 to 48	36, 40, 48	OFDM	BPSK	6.0	PIFA antenna, 3TX
	802.11n (HT20)		36 to 48	36, 40, 48	OFDM	BPSK	7.2	
	802.11n (HT40)		38 to 46	38, 46	OFDM	BPSK	15.0	
	802.11a	5745-5825	149 to 165	149, 157, 165	OFDM	BPSK	6.0	
	802.11n (HT20)		149 to 165	149, 157, 165	OFDM	BPSK	7.2	
	802.11n (HT40)		151 to 159	151, 159	OFDM	BPSK	15.0	
A2	802.11a	5180-5240	36 to 48	36, 40, 48	OFDM	BPSK	6.0	PIFA antenna, 1TX
	802.11a	5745-5825	149 to 165	149, 157, 165	OFDM	BPSK	6.0	



Test Condition:

APPLICABLE TO	ENVIRONMENTAL CONDITIONS	INPUT POWER (SYSTEM)	TESTED BY
RE \geq 1G	20deg. C, 66%RH, 20deg. C, 70%RH	120Vac, 60Hz	Jones Chang
RE<1G	18deg. C, 70%RH	120Vac, 60Hz	Jones Chang
PLC	20deg. C, 70%RH	120Vac, 60Hz	Jones Chang
APCM	25deg. C, 60%RH	120Vac, 60Hz	Nick Chen

3.3 Duty Cycle of Test Signal

Duty cycle of test signal is < 98 %, duty factor is required

3TX:

802.11a: Duty cycle = $1.357/1.407 = 0.964$, Duty factor = $10 * \log(1/0.964) = 0.16$

802.11n (HT20): Duty cycle = $1.270/1.320 = 0.962$, Duty factor = $10 * \log(1/0.962) = 0.17$

802.11n (HT40): Duty cycle = $0.627/0.665 = 0.943$, Duty factor = $10 * \log(1/0.943) = 0.26$

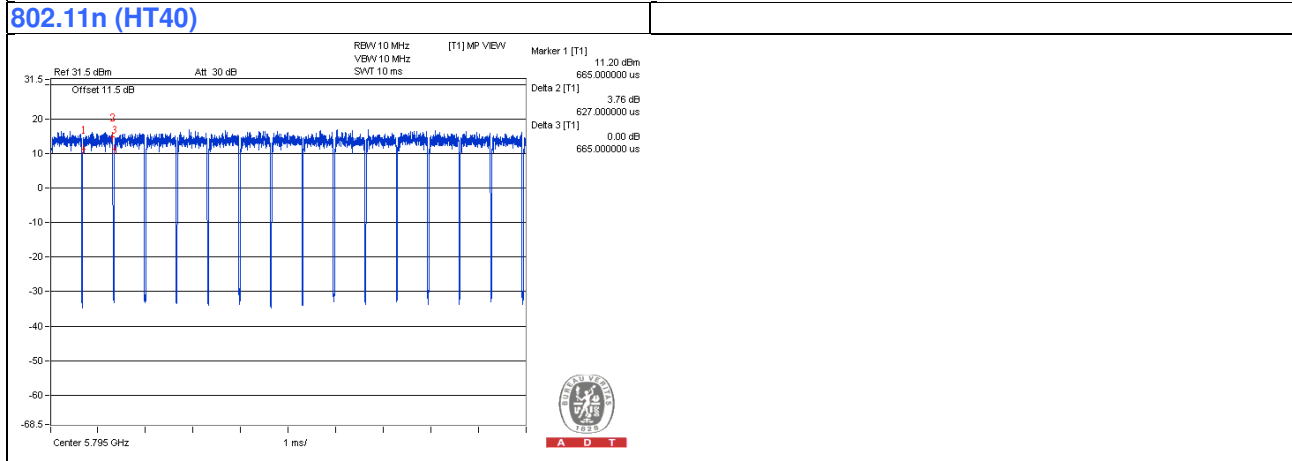
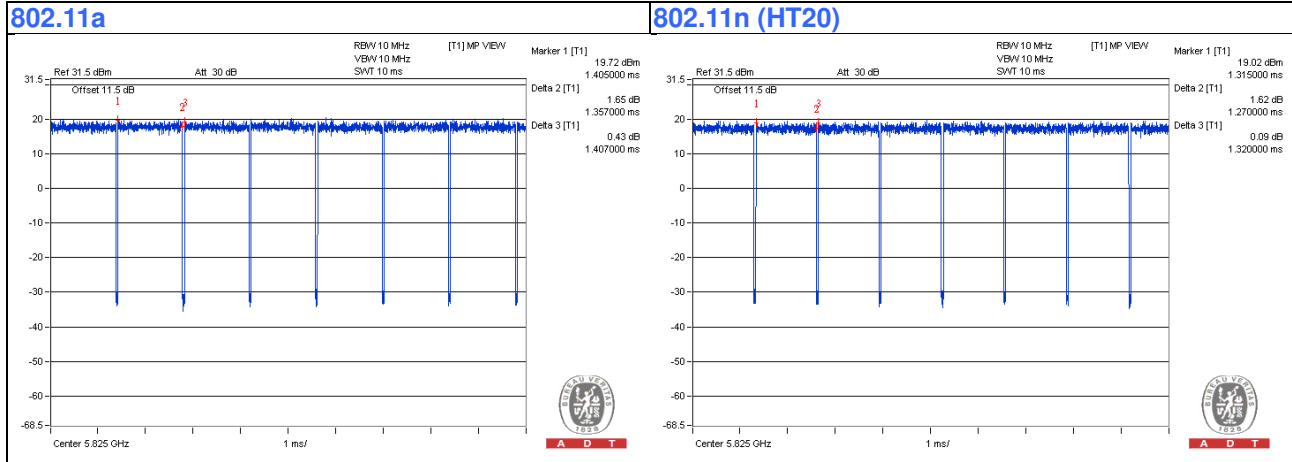

1TX:

802.11a: Duty cycle = $1.353/1.403 = 0.964$, Duty factor = $10 * \log(1/0.964) = 0.16$

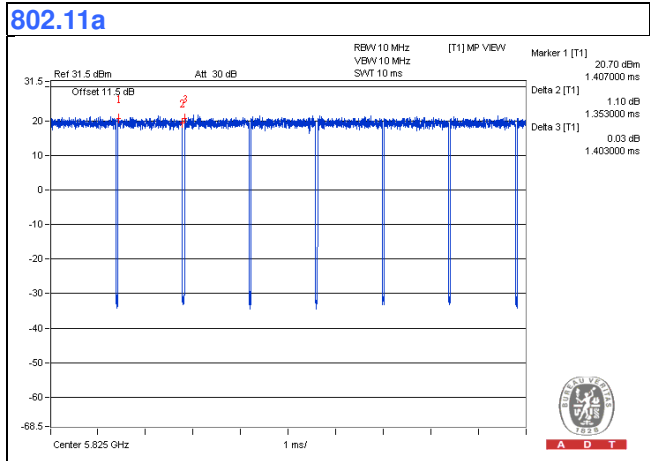

3.4 Description of Support Units

The EUT has been tested as an independent unit together with other necessary accessories or support units. The following support units or accessories were used to form a representative test configuration during the tests.

ID	Product	Brand	Model No.	Serial No.	FCC ID	Remarks
A.	Notebook	DELL	E5410	1HC2XM1	FCC DoC Approved	-
B.	Convertible board	NA	NA	NA	NA	Provided by client
C.	Power Supply	Topward	33010D	807748	NA	-

Note: All power cords of the above support units are non-shielded (1.8m).

ID	Descriptions	Qty.	Length (m)	Shielding (Yes/No)	Cores (Qty.)	Remarks
1.	Power	1	1.8	N	0	-

3.4.1 Configuration of System under Test

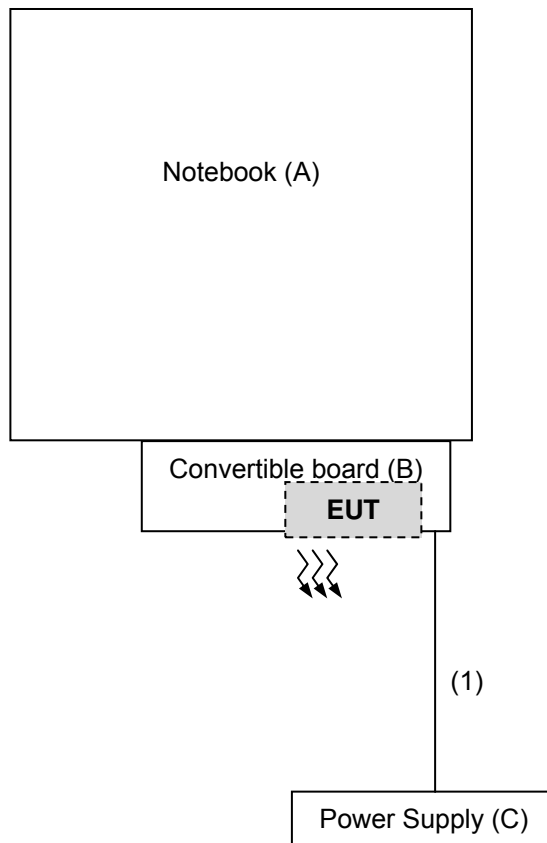

3.5 General Description of Applied Standards

The EUT is a RF Product. According to the specifications of the manufacturer, it must comply with the requirements of the following standards:

FCC Part 15, Subpart E (15.407)

789033 D02 General UNII Test Procedures New Rules v01

662911 D01 Multiple Transmitter Output v02r01

ANSI C63.10-2013

All test items have been performed and recorded as per the above standards.

4 Test Types and Results

4.1 Radiated Emission and Bandedge Measurement

4.1.1 Limits of Radiated Emission and Bandedge Measurement

Radiated emissions which fall in the restricted bands must comply with the radiated emission limits specified as below table. Other emissions shall be at least 20dB below the highest level of the desired power:

Frequencies (MHz)	Field Strength (microvolts/meter)	Measurement Distance (meters)
0.009 ~ 0.490	2400/F(kHz)	300
0.490 ~ 1.705	24000/F(kHz)	30
1.705 ~ 30.0	30	30
30 ~ 88	100	3
88 ~ 216	150	3
216 ~ 960	200	3
Above 960	500	3

NOTE:

1. The lower limit shall apply at the transition frequencies.
2. Emission level (dBuV/m) = 20 log Emission level (uV/m).
3. For frequencies above 1000MHz, the field strength limits are based on average detector, however, the peak field strength of any emission shall not exceed the maximum permitted average limits, specified above by more than 20dB under any condition of modulation.

LIMITS OF UNWANTED EMISSION OUT OF THE RESTRICTED BANDS

APPLICABLE TO	LIMIT	
789033 D02 General UNII Test Procedures New Rules v01	FIELD STRENGTH AT 3m	
	PK:74 (dBuV/m)	AV:54 (dBuV/m)
APPLICABLE TO	EIRP LIMIT	EQUIVALENT FIELD STRENGTH AT 3m
15.407(b)(1)	PK:-27 (dBm/MHz)	PK:68.2(dBuV/m)
15.407(b)(2)		
15.407(b)(3)		
15.407(b)(4)	PK:-27 (dBm/MHz) ^{*1} PK:-17 (dBm/MHz) ^{*2}	PK: 68.2(dBuV/m) ^{*1} PK: 78.2 (dBuV/m) ^{*2}

NOTE: ^{*1} beyond 10MHz of the band edge ^{*2} within 10 MHz of band edge

The following formula is used to convert the equipment isotropic radiated power (eirp) to field strength:

$$E = \frac{1000000\sqrt{30P}}{3} \mu\text{V/m, where P is the eirp (Watts).}$$

4.1.2 Test Instruments

Description & Manufacturer	Model No.	Serial No.	Cal. Date	Cal. Due
Test Receiver ROHDE & SCHWARZ	ESIB7	100187	Apr. 10, 2015	Apr. 09, 2016
Spectrum Analyzer ROHDE & SCHWARZ	FSP40	100040	Jul. 08, 2015	Jul. 07, 2016
BILOG Antenna SCHWARZBECK	VULB9168	9168-160	Feb. 05, 2015	Feb. 04, 2016
HORN Antenna SCHWARZBECK	9120D	209	Feb. 09, 2015	Feb. 08, 2016
HORN Antenna SCHWARZBECK	BBHA 9170	BBHA9170241	Feb. 09, 2015	Feb. 08, 2016
Preamplifier Agilent	8447D	2944A10738	Oct. 18, 2014	Oct. 17, 2015
Preamplifier Agilent	8449B	3008A01964	Aug. 22, 2014	Aug. 21, 2015
			Aug. 22, 2015	Aug. 21, 2016
RF signal cable HUBER+SUHNER	SUCOFLEX 104	Cable-CH3-03(214378)	Aug. 22, 2014	Aug. 21, 2015
			Aug. 22, 2015	Aug. 21, 2016
RF signal cable HUBER+SUHNER	SUCOFLEX 106	Cable-CH3-03(309224+12738)	Aug. 22, 2014	Aug. 21, 2015
			Aug. 22, 2015	Aug. 21, 2016
Software BV ADT	ADT_Radiated_V7.6.15.9.4	NA	NA	NA
Antenna Tower inn-co GmbH	MA 4000	013303	NA	NA
Antenna Tower Controller BV ADT	AT100	AT93021702	NA	NA
Turn Table BV ADT	TT100	TT93021702	NA	NA
Turn Table Controller BV ADT	SC100	SC93021702	NA	NA
26GHz ~ 40GHz Amplifier	EM26400	815221	Oct. 18, 2014	Oct. 17, 2015
High Speed Peak Power Meter	ML2495A	0824011	Jul. 09, 2015	Jul. 08, 2016
Power Sensor	MA2411B	0738171	Jul. 09, 2015	Jul. 08, 2016
WIT Standard Temperature And Humidity Chamber	TH-4S-C	W981030	Jun. 08, 2015	Jun. 07, 2016

- Note:
1. The calibration interval of the above test instruments is 12 months and the calibrations are traceable to NML/ROC and NIST/USA.
 2. The test was performed in HwaYa Chamber 3.
 3. The horn antenna and preamplifier (model: 8449B) are used only for the measurement of emission frequency above 1GHz if tested.
 4. The FCC Site Registration No. is 988962.
 5. The IC Site Registration No. is IC 7450F-3.

4.1.3 Test Procedures

- a. The EUT was placed on the top of a rotating table 0.8 meters (for below 1GHz) / 1.5 meters (for above 1GHz) above the ground at 3 meter chamber room for test. The table was rotated 360 degrees to determine the position of the highest radiation.
- b. The EUT was set 3 meters away from the interference-receiving antenna, which was mounted on the top of a variable-height antenna tower.
- c. The height of antenna is varied from one meter to four meters above the ground to determine the maximum value of the field strength. Both horizontal and vertical polarizations of the antenna are set to make the measurement.
- d. For each suspected emission, the EUT was arranged to its worst case and then the antenna was tuned to heights from 1 meter to 4 meters and the rotatable table was turned from 0 degrees to 360 degrees to find the maximum reading.
- e. The test-receiver system was set to quasi-peak detect function and specified bandwidth with maximum hold mode when the test frequency is below 1 GHz.
- f. The test-receiver system was set to peak and average detect function and specified bandwidth with maximum hold mode when the test frequency is above 1 GHz. If the peak reading value also meets average limit, measurement with the average detector is unnecessary.

Note:

1. The resolution bandwidth and video bandwidth of test receiver/spectrum analyzer is 120kHz for Quasi-peak detection (QP) at frequency below 1GHz.
2. The resolution bandwidth of test receiver/spectrum analyzer is 1 MHz and the video bandwidth is 3 MHz for Peak detection (PK) at frequency above 1GHz.
3. The resolution bandwidth of test receiver/spectrum analyzer is 1MHz and the video bandwidth is 3MHz for RMS Average (Duty cycle < 98%) for Average detection (AV) at frequency above 1GHz, then the measurement results was added to a correction factor ($10 \log(1/\text{duty cycle})$).
4. The resolution bandwidth of test receiver/spectrum analyzer is 1MHz and the video bandwidth is 10Hz (Duty cycle $\geq 98\%$) for Average detection (AV) at frequency above 1GHz.
5. All modes of operation were investigated and the worst-case emissions are reported.

4.1.4 Deviation from Test Standard

No deviation.

4.1.5 Test Set Up

<Frequency Range below 1GHz>

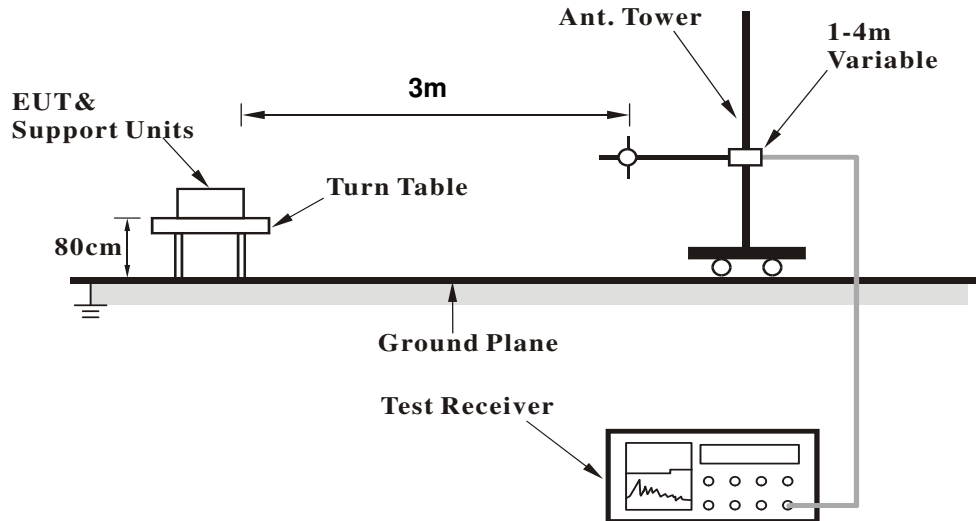

<Frequency Range above 1GHz>

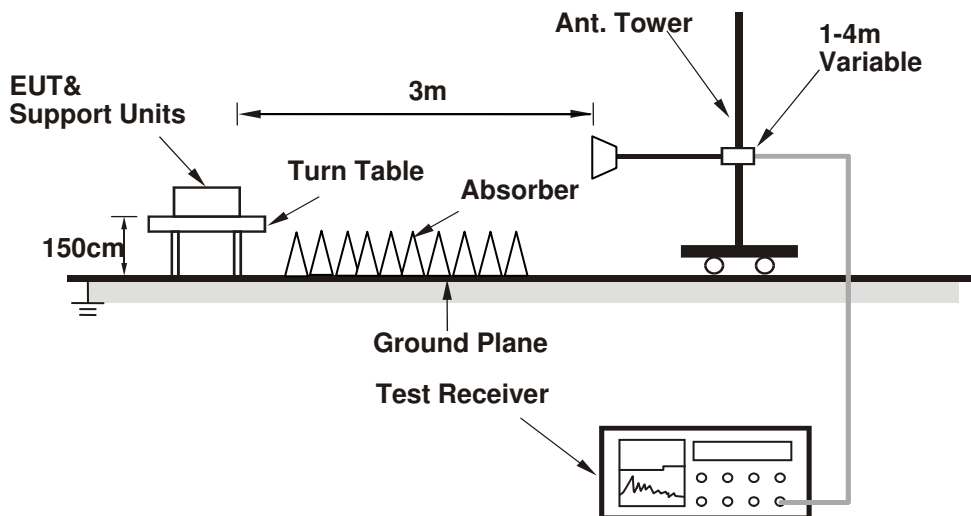

For the actual test configuration, please refer to the attached file (Test Setup Photo)

4.1.6 EUT Operating Conditions

- Plugged the EUT into notebook via a convertible board and placed them on the testing table.
- The notebook system ran a test program (provided by manufacturer) to enable EUT under transmission condition continuously at specific channel frequency.
- The necessary accessories enable the system in full functions.

4.1.7 Test Results

ABOVE 1GHz DATA

Test Mode A1 – PIFA Antenna: 3TX

802.11a

CHANNEL	TX Channel 36	DETECTOR FUNCTION	Peak (PK)
FREQUENCY RANGE	1GHz ~ 40GHz		Average (AV)

ANTENNA POLARITY & TEST DISTANCE: HORIZONTAL AT 3 M

NO.	FREQ. (MHz)	EMISSION LEVEL (dBuV/m)	LIMIT (dBuV/m)	MARGIN (dB)	ANTENNA HEIGHT (m)	TABLE ANGLE (Degree)	RAW VALUE (dBuV)	CORRECTION FACTOR (dB/m)
1	5150.00	66.6 PK	74.0	-7.4	1.38 H	37	60.40	6.20
2	5150.00	49.7 AV	54.0	-4.3	1.38 H	37	43.50	6.20
3	*5180.00	108.0 PK			1.42 H	173	68.50	39.50
4	*5180.00	98.7 AV			1.42 H	173	59.20	39.50
5	#10360.00	58.9 PK	74.0	-15.1	1.36 H	309	41.90	17.00
6	#10360.00	46.4 AV	54.0	-7.6	1.36 H	309	29.40	17.00

ANTENNA POLARITY & TEST DISTANCE: VERTICAL AT 3 M

NO.	FREQ. (MHz)	EMISSION LEVEL (dBuV/m)	LIMIT (dBuV/m)	MARGIN (dB)	ANTENNA HEIGHT (m)	TABLE ANGLE (Degree)	RAW VALUE (dBuV)	CORRECTION FACTOR (dB/m)
1	5150.00	72.6 PK	74.0	-1.4	1.00 V	139	66.40	6.20
2	5150.00	52.6 AV	54.0	-1.4	1.00 V	139	46.40	6.20
3	*5180.00	112.1 PK			1.00 V	6	72.60	39.50
4	*5180.00	102.2 AV			1.00 V	6	62.70	39.50
5	#10360.00	59.4 PK	74.0	-14.6	1.08 V	166	42.40	17.00
6	#10360.00	48.4 AV	54.0	-5.6	1.08 V	166	31.40	17.00

REMARKS:

1. Emission Level(dBuV/m) = Raw Value(dBuV) + Correction Factor(dB/m)
2. Correction Factor(dB/m) = Antenna Factor(dB/m) + Cable Factor(dB)
3. The other emission levels were very low against the limit.
4. Margin value = Emission Level – Limit value
5. " * ": Fundamental frequency.
6. " # ": The radiated frequency is out of the restricted band.

CHANNEL	TX Channel 40	DETECTOR FUNCTION	Peak (PK)
FREQUENCY RANGE	1GHz ~ 40GHz		Average (AV)

ANTENNA POLARITY & TEST DISTANCE: HORIZONTAL AT 3 M

NO.	FREQ. (MHz)	EMISSION LEVEL (dBuV/m)	LIMIT (dBuV/m)	MARGIN (dB)	ANTENNA HEIGHT (m)	TABLE ANGLE (Degree)	RAW VALUE (dBuV)	CORRECTION FACTOR (dB/m)
1	5150.00	62.6 PK	74.0	-11.4	1.24 H	40	56.40	6.20
2	5150.00	47.5 AV	54.0	-6.5	1.24 H	40	41.30	6.20
3	*5200.00	111.4 PK			1.22 H	356	71.90	39.50
4	*5200.00	100.8 AV			1.22 H	356	61.30	39.50
5	#10400.00	57.9 PK	74.0	-16.1	1.20 H	175	40.90	17.00
6	#10400.00	46.5 AV	54.0	-7.5	1.20 H	175	29.50	17.00

ANTENNA POLARITY & TEST DISTANCE: VERTICAL AT 3 M

NO.	FREQ. (MHz)	EMISSION LEVEL (dBuV/m)	LIMIT (dBuV/m)	MARGIN (dB)	ANTENNA HEIGHT (m)	TABLE ANGLE (Degree)	RAW VALUE (dBuV)	CORRECTION FACTOR (dB/m)
1	5150.00	64.1 PK	74.0	-9.9	1.07 V	46	57.90	6.20
2	5150.00	49.1 AV	54.0	-4.9	1.07 V	46	42.90	6.20
3	*5200.00	115.7 PK			1.06 V	29	76.10	39.60
4	*5200.00	105.1 AV			1.06 V	29	65.50	39.60
5	#10400.00	61.5 PK	74.0	-12.5	1.00 V	165	44.50	17.00
6	#10400.00	48.8 AV	54.0	-5.2	1.00 V	165	31.80	17.00

REMARKS:

1. Emission Level(dBuV/m) = Raw Value(dBuV) + Correction Factor(dB/m)
2. Correction Factor(dB/m) = Antenna Factor(dB/m) + Cable Factor(dB)
3. The other emission levels were very low against the limit.
4. Margin value = Emission Level – Limit value
5. " * ": Fundamental frequency.
6. " # ": The radiated frequency is out of the restricted band.



CHANNEL	TX Channel 48	DETECTOR FUNCTION	Peak (PK)
FREQUENCY RANGE	1GHz ~ 40GHz		Average (AV)

ANTENNA POLARITY & TEST DISTANCE: HORIZONTAL AT 3 M

NO.	FREQ. (MHz)	EMISSION LEVEL (dBuV/m)	LIMIT (dBuV/m)	MARGIN (dB)	ANTENNA HEIGHT (m)	TABLE ANGLE (Degree)	RAW VALUE (dBuV)	CORRECTION FACTOR (dB/m)
1	5120.00	57.2 PK	74.0	-16.8	1.25 H	169	51.00	6.20
2	5120.00	45.3 AV	54.0	-8.7	1.25 H	169	39.10	6.20
3	*5240.00	112.1 PK			1.38 H	37	72.50	39.60
4	*5240.00	101.6 AV			1.38 H	37	62.00	39.60
5	#10480.00	58.2 PK	74.0	-15.8	1.22 H	186	40.20	18.00
6	#10480.00	45.9 AV	54.0	-8.1	1.22 H	186	27.90	18.00

ANTENNA POLARITY & TEST DISTANCE: VERTICAL AT 3 M

NO.	FREQ. (MHz)	EMISSION LEVEL (dBuV/m)	LIMIT (dBuV/m)	MARGIN (dB)	ANTENNA HEIGHT (m)	TABLE ANGLE (Degree)	RAW VALUE (dBuV)	CORRECTION FACTOR (dB/m)
1	5120.00	58.0 PK	74.0	-16.0	1.00 V	4	51.80	6.20
2	5120.00	46.6 AV	54.0	-7.4	1.00 V	4	40.40	6.20
3	*5240.00	117.4 PK			1.50 V	37	77.80	39.60
4	*5240.00	106.5 AV			1.50 V	37	66.90	39.60
5	#10480.00	60.3 PK	74.0	-13.7	1.16 V	175	42.30	18.00
6	#10480.00	48.1 AV	54.0	-5.9	1.16 V	175	30.10	18.00

REMARKS:

1. Emission Level(dBuV/m) = Raw Value(dBuV) + Correction Factor(dB/m)
2. Correction Factor(dB/m) = Antenna Factor(dB/m) + Cable Factor(dB)
3. The other emission levels were very low against the limit.
4. Margin value = Emission Level – Limit value
5. " * ": Fundamental frequency.
6. " # ": The radiated frequency is out of the restricted band.

CHANNEL	TX Channel 149	DETECTOR FUNCTION	Peak (PK)
FREQUENCY RANGE	1GHz ~ 40GHz		Average (AV)

ANTENNA POLARITY & TEST DISTANCE: HORIZONTAL AT 3 M

NO.	FREQ. (MHz)	EMISSION LEVEL (dBuV/m)	LIMIT (dBuV/m)	MARGIN (dB)	ANTENNA HEIGHT (m)	TABLE ANGLE (Degree)	RAW VALUE (dBuV)	CORRECTION FACTOR (dB/m)
1	#5714.90	63.9 PK	74.0	-10.1	1.59 H	22	56.70	7.20
2	#5714.90	47.4 AV	54.0	-6.6	1.59 H	22	40.20	7.20
3	#5722.90	71.3 PK	78.2	-6.9	1.60 H	36	64.10	7.20
4	#5725.00	60.9 PK	78.2	-17.3	1.61 H	33	53.70	7.20
5	*5745.00	108.4 PK			1.86 H	32	68.00	40.40
6	*5745.00	98.4 AV			1.86 H	32	58.00	40.40
7	11490.00	59.3 PK	74.0	-14.7	1.23 H	136	41.00	18.30
8	11490.00	46.2 AV	54.0	-7.8	1.23 H	136	27.90	18.30

ANTENNA POLARITY & TEST DISTANCE: VERTICAL AT 3 M

NO.	FREQ. (MHz)	EMISSION LEVEL (dBuV/m)	LIMIT (dBuV/m)	MARGIN (dB)	ANTENNA HEIGHT (m)	TABLE ANGLE (Degree)	RAW VALUE (dBuV)	CORRECTION FACTOR (dB/m)
1	#5714.90	63.9 PK	74.0	-10.1	1.21 V	19	56.70	7.20
2	#5714.90	47.9 AV	54.0	-6.1	1.21 V	19	40.70	7.20
3	#5722.90	76.4 PK	78.2	-1.8	1.00 V	0	69.20	7.20
4	#5725.00	62.2 PK	78.2	-16.0	1.09 V	28	55.00	7.20
5	*5745.00	109.8 PK			1.00 V	3	69.40	40.40
6	*5745.00	99.8 AV			1.00 V	3	59.40	40.40
7	11490.00	59.0 PK	74.0	-15.0	1.08 V	275	40.70	18.30
8	11490.00	46.1 AV	54.0	-7.9	1.08 V	275	27.80	18.30

REMARKS:

1. Emission Level(dBuV/m) = Raw Value(dBuV) + Correction Factor(dB/m)
2. Correction Factor(dB/m) = Antenna Factor(dB/m) + Cable Factor(dB)
3. The other emission levels were very low against the limit.
4. Margin value = Emission Level – Limit value
5. " * ": Fundamental frequency.
6. " # ": The radiated frequency is out of the restricted band.

CHANNEL	TX Channel 157	DETECTOR FUNCTION	Peak (PK)
FREQUENCY RANGE	1GHz ~ 40GHz		Average (AV)

ANTENNA POLARITY & TEST DISTANCE: HORIZONTAL AT 3 M

NO.	FREQ. (MHz)	EMISSION LEVEL (dBuV/m)	LIMIT (dBuV/m)	MARGIN (dB)	ANTENNA HEIGHT (m)	TABLE ANGLE (Degree)	RAW VALUE (dBuV)	CORRECTION FACTOR (dB/m)
1	5080.00	57.7 PK	74.0	-16.3	1.30 H	33	51.70	6.00
2	5080.00	47.0 AV	54.0	-7.0	1.30 H	33	41.00	6.00
3	*5785.00	109.3 PK			1.42 H	268	68.80	40.50
4	*5785.00	99.7 AV			1.42 H	268	59.20	40.50
5	11570.00	59.0 PK	74.0	-15.0	1.19 H	154	40.80	18.20
6	11570.00	46.5 AV	54.0	-7.5	1.19 H	154	28.30	18.20

ANTENNA POLARITY & TEST DISTANCE: VERTICAL AT 3 M

NO.	FREQ. (MHz)	EMISSION LEVEL (dBuV/m)	LIMIT (dBuV/m)	MARGIN (dB)	ANTENNA HEIGHT (m)	TABLE ANGLE (Degree)	RAW VALUE (dBuV)	CORRECTION FACTOR (dB/m)
1	5080.00	60.6 PK	74.0	-13.4	1.01 V	1	54.60	6.00
2	5080.00	52.2 AV	54.0	-1.8	1.01 V	1	46.20	6.00
3	*5785.00	113.8 PK			1.40 V	279	73.30	40.50
4	*5785.00	103.7 AV			1.40 V	279	63.20	40.50
5	11570.00	58.3 PK	74.0	-15.7	1.26 V	193	40.10	18.20
6	11570.00	46.1 AV	54.0	-7.9	1.26 V	193	27.90	18.20

REMARKS:

1. Emission Level(dBuV/m) = Raw Value(dBuV) + Correction Factor(dB/m)
2. Correction Factor(dB/m) = Antenna Factor(dB/m) + Cable Factor(dB)
3. The other emission levels were very low against the limit.
4. Margin value = Emission Level – Limit value
5. " * ": Fundamental frequency.

CHANNEL	TX Channel 165	DETECTOR FUNCTION	Peak (PK)
FREQUENCY RANGE	1GHz ~ 40GHz		Average (AV)

ANTENNA POLARITY & TEST DISTANCE: HORIZONTAL AT 3 M

NO.	FREQ. (MHz)	EMISSION LEVEL (dBuV/m)	LIMIT (dBuV/m)	MARGIN (dB)	ANTENNA HEIGHT (m)	TABLE ANGLE (Degree)	RAW VALUE (dBuV)	CORRECTION FACTOR (dB/m)
1	5120.00	58.6 PK	74.0	-15.4	1.20 H	262	52.40	6.20
2	5120.00	47.2 AV	54.0	-6.8	1.20 H	262	41.00	6.20
3	*5825.00	110.7 PK			1.27 H	265	70.20	40.50
4	*5825.00	100.3 AV			1.27 H	265	59.80	40.50
5	#5850.00	52.9 PK	78.2	-25.3	1.30 H	264	45.40	7.50
6	#5852.10	68.4 PK	78.2	-9.8	1.46 H	275	60.80	7.60
7	#5860.10	62.6 PK	74.0	-11.4	1.46 H	261	55.00	7.60
8	#5860.10	47.4 AV	54.0	-6.6	1.46 H	261	39.80	7.60
9	11650.00	58.9 PK	74.0	-15.1	1.11 H	182	40.20	18.70
10	11650.00	46.6 AV	54.0	-7.4	1.11 H	182	27.90	18.70

ANTENNA POLARITY & TEST DISTANCE: VERTICAL AT 3 M

NO.	FREQ. (MHz)	EMISSION LEVEL (dBuV/m)	LIMIT (dBuV/m)	MARGIN (dB)	ANTENNA HEIGHT (m)	TABLE ANGLE (Degree)	RAW VALUE (dBuV)	CORRECTION FACTOR (dB/m)
1	5120.00	62.0 PK	74.0	-12.0	1.00 V	359	55.80	6.20
2	5120.00	52.2 AV	54.0	-1.8	1.00 V	359	46.00	6.20
3	*5825.00	111.9 PK			1.07 V	27	71.40	40.50
4	*5825.00	102.1 AV			1.07 V	27	61.60	40.50
5	#5850.00	56.0 PK	78.2	-22.2	1.00 V	29	48.50	7.50
6	#5852.10	74.5 PK	78.2	-3.7	1.06 V	8	66.90	7.60
7	#5860.10	64.8 PK	74.0	-9.2	1.05 V	28	57.20	7.60
8	#5860.10	48.3 AV	54.0	-5.7	1.05 V	28	40.70	7.60
9	11650.00	59.5 PK	74.0	-14.5	1.12 V	98	40.80	18.70
10	11650.00	46.7 AV	54.0	-7.3	1.12 V	98	28.00	18.70

REMARKS:

1. Emission Level(dBuV/m) = Raw Value(dBuV) + Correction Factor(dB/m)
2. Correction Factor(dB/m) = Antenna Factor(dB/m) + Cable Factor(dB)
3. The other emission levels were very low against the limit.
4. Margin value = Emission Level – Limit value
5. " * ": Fundamental frequency.
6. " # ": The radiated frequency is out of the restricted band.

802.11n (HT20)

CHANNEL	TX Channel 36	DETECTOR FUNCTION	Peak (PK)
FREQUENCY RANGE	1GHz ~ 40GHz		Average (AV)

ANTENNA POLARITY & TEST DISTANCE: HORIZONTAL AT 3 M								
NO.	FREQ. (MHz)	EMISSION LEVEL (dBuV/m)	LIMIT (dBuV/m)	MARGIN (dB)	ANTENNA HEIGHT (m)	TABLE ANGLE (Degree)	RAW VALUE (dBuV)	CORRECTION FACTOR (dB/m)
1	5150.00	64.6 PK	74.0	-9.4	1.25 H	20	58.40	6.20
2	5150.00	48.8 AV	54.0	-5.2	1.25 H	20	42.60	6.20
3	*5180.00	108.9 PK			1.24 H	346	69.40	39.50
4	*5180.00	98.8 AV			1.24 H	346	59.30	39.50
5	#10360.00	57.8 PK	74.0	-16.2	1.17 H	191	40.80	17.00
6	#10360.00	46.0 AV	54.0	-8.0	1.17 H	191	29.00	17.00

ANTENNA POLARITY & TEST DISTANCE: VERTICAL AT 3 M								
NO.	FREQ. (MHz)	EMISSION LEVEL (dBuV/m)	LIMIT (dBuV/m)	MARGIN (dB)	ANTENNA HEIGHT (m)	TABLE ANGLE (Degree)	RAW VALUE (dBuV)	CORRECTION FACTOR (dB/m)
1	5150.00	68.7 PK	74.0	-5.3	1.00 V	6	62.50	6.20
2	5150.00	52.6 AV	54.0	-1.4	1.00 V	6	46.40	6.20
3	*5180.00	111.8 PK			1.00 V	145	72.30	39.50
4	*5180.00	102.7 AV			1.00 V	145	63.20	39.50
5	#10360.00	58.8 PK	74.0	-15.2	1.21 V	165	41.80	17.00
6	#10360.00	46.4 AV	54.0	-7.6	1.21 V	165	29.40	17.00

REMARKS:

1. Emission Level(dBuV/m) = Raw Value(dBuV) + Correction Factor(dB/m)
2. Correction Factor(dB/m) = Antenna Factor(dB/m) + Cable Factor(dB)
3. The other emission levels were very low against the limit.
4. Margin value = Emission Level – Limit value
5. " * ": Fundamental frequency.
6. " # ": The radiated frequency is out of the restricted band.

CHANNEL	TX Channel 40	DETECTOR FUNCTION	Peak (PK)
FREQUENCY RANGE	1GHz ~ 40GHz		Average (AV)

ANTENNA POLARITY & TEST DISTANCE: HORIZONTAL AT 3 M

NO.	FREQ. (MHz)	EMISSION LEVEL (dBuV/m)	LIMIT (dBuV/m)	MARGIN (dB)	ANTENNA HEIGHT (m)	TABLE ANGLE (Degree)	RAW VALUE (dBuV)	CORRECTION FACTOR (dB/m)
1	5150.00	63.9 PK	74.0	-10.1	1.45 H	173	57.70	6.20
2	5150.00	48.3 AV	54.0	-5.7	1.45 H	173	42.10	6.20
3	*5200.00	111.0 PK			1.44 H	38	71.40	39.60
4	*5200.00	100.3 AV			1.44 H	38	60.70	39.60
5	#10400.00	58.5 PK	74.0	-15.5	1.07 H	202	41.50	17.00
6	#10400.00	46.2 AV	54.0	-7.8	1.07 H	202	29.20	17.00

ANTENNA POLARITY & TEST DISTANCE: VERTICAL AT 3 M

NO.	FREQ. (MHz)	EMISSION LEVEL (dBuV/m)	LIMIT (dBuV/m)	MARGIN (dB)	ANTENNA HEIGHT (m)	TABLE ANGLE (Degree)	RAW VALUE (dBuV)	CORRECTION FACTOR (dB/m)
1	5150.00	70.6 PK	74.0	-3.4	1.00 V	4	64.40	6.20
2	5150.00	51.9 AV	54.0	-2.1	1.00 V	4	45.70	6.20
3	*5200.00	115.1 PK			1.06 V	7	75.50	39.60
4	*5200.00	105.0 AV			1.06 V	7	65.40	39.60
5	#10400.00	62.2 PK	74.0	-11.8	1.24 V	166	45.20	17.00
6	#10400.00	48.8 AV	54.0	-5.2	1.24 V	166	31.80	17.00

REMARKS:

1. Emission Level(dBuV/m) = Raw Value(dBuV) + Correction Factor(dB/m)
2. Correction Factor(dB/m) = Antenna Factor(dB/m) + Cable Factor(dB)
3. The other emission levels were very low against the limit.
4. Margin value = Emission Level – Limit value
5. " * ": Fundamental frequency.
6. " # ": The radiated frequency is out of the restricted band.

CHANNEL	TX Channel 48	DETECTOR FUNCTION	Peak (PK)
FREQUENCY RANGE	1GHz ~ 40GHz		Average (AV)

ANTENNA POLARITY & TEST DISTANCE: HORIZONTAL AT 3 M

NO.	FREQ. (MHz)	EMISSION LEVEL (dBuV/m)	LIMIT (dBuV/m)	MARGIN (dB)	ANTENNA HEIGHT (m)	TABLE ANGLE (Degree)	RAW VALUE (dBuV)	CORRECTION FACTOR (dB/m)
1	5080.00	56.7 PK	74.0	-17.3	1.14 H	99	50.70	6.00
2	5080.00	44.9 AV	54.0	-9.1	1.14 H	99	38.90	6.00
3	*5240.00	111.3 PK			1.16 H	186	71.70	39.60
4	*5240.00	100.6 AV			1.16 H	186	61.00	39.60
5	#10480.00	58.6 PK	74.0	-15.4	1.22 H	176	40.60	18.00
6	#10480.00	46.2 AV	54.0	-7.8	1.22 H	176	28.20	18.00

ANTENNA POLARITY & TEST DISTANCE: VERTICAL AT 3 M

NO.	FREQ. (MHz)	EMISSION LEVEL (dBuV/m)	LIMIT (dBuV/m)	MARGIN (dB)	ANTENNA HEIGHT (m)	TABLE ANGLE (Degree)	RAW VALUE (dBuV)	CORRECTION FACTOR (dB/m)
1	5080.00	58.2 PK	74.0	-15.8	1.39 V	7	52.20	6.00
2	5080.00	48.1 AV	54.0	-5.9	1.39 V	7	42.10	6.00
3	*5240.00	114.6 PK			1.33 V	293	75.00	39.60
4	*5240.00	103.8 AV			1.33 V	293	64.20	39.60
5	#10480.00	59.6 PK	74.0	-14.4	1.28 V	29	41.60	18.00
6	#10480.00	47.3 AV	54.0	-6.7	1.28 V	29	29.30	18.00

REMARKS:

1. Emission Level(dBuV/m) = Raw Value(dBuV) + Correction Factor(dB/m)
2. Correction Factor(dB/m) = Antenna Factor(dB/m) + Cable Factor(dB)
3. The other emission levels were very low against the limit.
4. Margin value = Emission Level – Limit value
5. " * ": Fundamental frequency.
6. " # ": The radiated frequency is out of the restricted band.



CHANNEL	TX Channel 149	DETECTOR FUNCTION	Peak (PK)
FREQUENCY RANGE	1GHz ~ 40GHz		Average (AV)

ANTENNA POLARITY & TEST DISTANCE: HORIZONTAL AT 3 M

NO.	FREQ. (MHz)	EMISSION LEVEL (dBuV/m)	LIMIT (dBuV/m)	MARGIN (dB)	ANTENNA HEIGHT (m)	TABLE ANGLE (Degree)	RAW VALUE (dBuV)	CORRECTION FACTOR (dB/m)
1	#5714.90	61.2 PK	74.0	-12.8	1.21 H	33	54.00	7.20
2	#5714.90	46.6 AV	54.0	-7.4	1.21 H	33	39.40	7.20
3	#5722.90	73.9 PK	78.2	-4.3	1.27 H	33	66.70	7.20
4	#5725.00	59.3 PK	78.2	-18.9	1.25 H	30	52.10	7.20
5	*5745.00	106.8 PK			1.86 H	34	66.40	40.40
6	*5745.00	96.4 AV			1.86 H	34	56.00	40.40
7	11490.00	58.9 PK	74.0	-15.1	1.12 H	109	40.60	18.30
8	11490.00	45.8 AV	54.0	-8.2	1.12 H	109	27.50	18.30

ANTENNA POLARITY & TEST DISTANCE: VERTICAL AT 3 M

NO.	FREQ. (MHz)	EMISSION LEVEL (dBuV/m)	LIMIT (dBuV/m)	MARGIN (dB)	ANTENNA HEIGHT (m)	TABLE ANGLE (Degree)	RAW VALUE (dBuV)	CORRECTION FACTOR (dB/m)
1	#5714.90	64.5 PK	74.0	-9.5	1.42 V	1	57.30	7.20
2	#5714.90	47.5 AV	54.0	-6.5	1.42 V	1	40.30	7.20
3	#5722.90	76.7 PK	78.2	-1.5	1.41 V	358	69.50	7.20
4	#5725.00	58.8 PK	78.2	-19.4	1.41 V	357	51.60	7.20
5	*5745.00	107.2 PK			1.00 V	128	66.80	40.40
6	*5745.00	97.9 AV			1.00 V	128	57.50	40.40
7	11490.00	58.4 PK	74.0	-15.6	1.12 V	84	40.10	18.30
8	11490.00	45.5 AV	54.0	-8.5	1.12 V	84	27.20	18.30

REMARKS:

1. Emission Level(dBuV/m) = Raw Value(dBuV) + Correction Factor(dB/m)
2. Correction Factor(dB/m) = Antenna Factor(dB/m) + Cable Factor(dB)
3. The other emission levels were very low against the limit.
4. Margin value = Emission Level – Limit value
5. " * ": Fundamental frequency.
6. " # ": The radiated frequency is out of the restricted band.

CHANNEL	TX Channel 157	DETECTOR FUNCTION	Peak (PK)
FREQUENCY RANGE	1GHz ~ 40GHz		Average (AV)

ANTENNA POLARITY & TEST DISTANCE: HORIZONTAL AT 3 M

NO.	FREQ. (MHz)	EMISSION LEVEL (dBuV/m)	LIMIT (dBuV/m)	MARGIN (dB)	ANTENNA HEIGHT (m)	TABLE ANGLE (Degree)	RAW VALUE (dBuV)	CORRECTION FACTOR (dB/m)
1	5120.00	58.0 PK	74.0	-16.0	1.28 H	18	51.80	6.20
2	5120.00	48.4 AV	54.0	-5.6	1.28 H	18	42.20	6.20
3	*5785.00	107.6 PK			1.00 H	318	67.10	40.50
4	*5785.00	98.7 AV			1.00 H	318	58.20	40.50
5	11570.00	58.6 PK	74.0	-15.4	1.08 H	222	40.40	18.20
6	11570.00	46.0 AV	54.0	-8.0	1.08 H	222	27.80	18.20

ANTENNA POLARITY & TEST DISTANCE: VERTICAL AT 3 M

NO.	FREQ. (MHz)	EMISSION LEVEL (dBuV/m)	LIMIT (dBuV/m)	MARGIN (dB)	ANTENNA HEIGHT (m)	TABLE ANGLE (Degree)	RAW VALUE (dBuV)	CORRECTION FACTOR (dB/m)
1	5120.00	61.1 PK	74.0	-12.9	1.00 V	1	54.90	6.20
2	5120.00	52.3 AV	54.0	-1.7	1.00 V	1	46.10	6.20
3	*5785.00	112.2 PK			1.00 V	25	71.70	40.50
4	*5785.00	102.0 AV			1.00 V	25	61.50	40.50
5	11570.00	58.6 PK	74.0	-15.4	1.16 V	141	40.40	18.20
6	11570.00	46.3 AV	54.0	-7.7	1.16 V	141	28.10	18.20

REMARKS:

1. Emission Level(dBuV/m) = Raw Value(dBuV) + Correction Factor(dB/m)
2. Correction Factor(dB/m) = Antenna Factor(dB/m) + Cable Factor(dB)
3. The other emission levels were very low against the limit.
4. Margin value = Emission Level – Limit value
5. " * ": Fundamental frequency.

CHANNEL	TX Channel 165	DETECTOR FUNCTION	Peak (PK)
FREQUENCY RANGE	1GHz ~ 40GHz		Average (AV)

ANTENNA POLARITY & TEST DISTANCE: HORIZONTAL AT 3 M

NO.	FREQ. (MHz)	EMISSION LEVEL (dBuV/m)	LIMIT (dBuV/m)	MARGIN (dB)	ANTENNA HEIGHT (m)	TABLE ANGLE (Degree)	RAW VALUE (dBuV)	CORRECTION FACTOR (dB/m)
1	5080.00	58.7 PK	74.0	-15.3	1.05 H	260	52.70	6.00
2	5080.00	46.9 AV	54.0	-7.1	1.05 H	260	40.90	6.00
3	*5825.00	110.1 PK			1.16 H	268	69.60	40.50
4	*5825.00	99.8 AV			1.16 H	268	59.30	40.50
5	#5850.00	57.1 PK	78.2	-21.1	1.16 H	269	49.60	7.50
6	#5852.10	72.0 PK	78.2	-6.2	1.23 H	265	64.40	7.60
7	#5860.10	61.0 PK	74.0	-13.0	1.23 H	264	53.40	7.60
8	#5860.10	47.0 AV	54.0	-7.0	1.23 H	264	39.40	7.60
9	11650.00	59.2 PK	74.0	-14.8	1.12 H	211	40.50	18.70
10	11650.00	46.7 AV	54.0	-7.3	1.12 H	211	28.00	18.70

ANTENNA POLARITY & TEST DISTANCE: VERTICAL AT 3 M

NO.	FREQ. (MHz)	EMISSION LEVEL (dBuV/m)	LIMIT (dBuV/m)	MARGIN (dB)	ANTENNA HEIGHT (m)	TABLE ANGLE (Degree)	RAW VALUE (dBuV)	CORRECTION FACTOR (dB/m)
1	5080.00	60.3 PK	74.0	-13.7	1.00 V	3	54.30	6.00
2	5080.00	52.2 AV	54.0	-1.8	1.00 V	3	46.20	6.00
3	*5825.00	112.3 PK			1.47 V	6	71.80	40.50
4	*5825.00	101.9 AV			1.47 V	6	61.40	40.50
5	#5850.00	57.5 PK	78.2	-20.7	1.05 V	3	50.00	7.50
6	#5852.10	71.2 PK	78.2	-7.0	1.00 V	19	63.60	7.60
7	#5860.10	64.1 PK	74.0	-9.9	1.04 V	12	56.50	7.60
8	#5860.10	49.5 AV	54.0	-4.5	1.04 V	12	41.90	7.60
9	11650.00	59.1 PK	74.0	-14.9	1.23 V	8	40.40	18.70
10	11650.00	47.0 AV	54.0	-7.0	1.23 V	8	28.30	18.70

REMARKS:

1. Emission Level(dBuV/m) = Raw Value(dBuV) + Correction Factor(dB/m)
2. Correction Factor(dB/m) = Antenna Factor(dB/m) + Cable Factor(dB)
3. The other emission levels were very low against the limit.
4. Margin value = Emission Level – Limit value
5. " * ": Fundamental frequency.
6. " # ": The radiated frequency is out of the restricted band.

802.11n (HT40)

CHANNEL	TX Channel 38	DETECTOR FUNCTION	Peak (PK)
FREQUENCY RANGE	1GHz ~ 40GHz		Average (AV)

ANTENNA POLARITY & TEST DISTANCE: HORIZONTAL AT 3 M								
NO.	FREQ. (MHz)	EMISSION LEVEL (dBuV/m)	LIMIT (dBuV/m)	MARGIN (dB)	ANTENNA HEIGHT (m)	TABLE ANGLE (Degree)	RAW VALUE (dBuV)	CORRECTION FACTOR (dB/m)
1	5150.00	66.5 PK	74.0	-7.5	1.14 H	355	60.30	6.20
2	5150.00	50.8 AV	54.0	-3.2	1.14 H	355	44.60	6.20
3	*5190.00	101.1 PK			1.00 H	37	61.60	39.50
4	*5190.00	92.2 AV			1.00 H	37	52.70	39.50
5	#10380.00	58.7 PK	74.0	-15.3	1.20 H	88	41.70	17.00
6	#10380.00	46.6 AV	54.0	-7.4	1.20 H	88	29.60	17.00

ANTENNA POLARITY & TEST DISTANCE: VERTICAL AT 3 M								
NO.	FREQ. (MHz)	EMISSION LEVEL (dBuV/m)	LIMIT (dBuV/m)	MARGIN (dB)	ANTENNA HEIGHT (m)	TABLE ANGLE (Degree)	RAW VALUE (dBuV)	CORRECTION FACTOR (dB/m)
1	5150.00	70.2 PK	74.0	-3.8	1.00 V	109	64.00	6.20
2	5150.00	52.5 AV	54.0	-1.5	1.00 V	109	46.30	6.20
3	*5190.00	106.1 PK			1.00 V	47	66.60	39.50
4	*5190.00	97.1 AV			1.00 V	47	57.60	39.50
5	#10380.00	58.3 PK	74.0	-15.7	1.10 V	36	41.30	17.00
6	#10380.00	46.6 AV	54.0	-7.4	1.10 V	36	29.60	17.00

REMARKS:

1. Emission Level(dBuV/m) = Raw Value(dBuV) + Correction Factor(dB/m)
2. Correction Factor(dB/m) = Antenna Factor(dB/m) + Cable Factor(dB)
3. The other emission levels were very low against the limit.
4. Margin value = Emission Level – Limit value
5. " * ": Fundamental frequency.
6. " # ": The radiated frequency is out of the restricted band.

CHANNEL	TX Channel 46	DETECTOR FUNCTION	Peak (PK)
FREQUENCY RANGE	1GHz ~ 40GHz		Average (AV)

ANTENNA POLARITY & TEST DISTANCE: HORIZONTAL AT 3 M

NO.	FREQ. (MHz)	EMISSION LEVEL (dBuV/m)	LIMIT (dBuV/m)	MARGIN (dB)	ANTENNA HEIGHT (m)	TABLE ANGLE (Degree)	RAW VALUE (dBuV)	CORRECTION FACTOR (dB/m)
1	5150.00	62.4 PK	74.0	-11.6	1.02 H	36	56.20	6.20
2	5150.00	48.7 AV	54.0	-5.3	1.02 H	36	42.50	6.20
3	*5230.00	106.6 PK			1.00 H	131	67.00	39.60
4	*5230.00	98.0 AV			1.00 H	131	58.40	39.60
5	#10460.00	58.1 PK	74.0	-15.9	1.26 H	276	40.30	17.80
6	#10460.00	47.1 AV	54.0	-6.9	1.26 H	276	29.30	17.80

ANTENNA POLARITY & TEST DISTANCE: VERTICAL AT 3 M

NO.	FREQ. (MHz)	EMISSION LEVEL (dBuV/m)	LIMIT (dBuV/m)	MARGIN (dB)	ANTENNA HEIGHT (m)	TABLE ANGLE (Degree)	RAW VALUE (dBuV)	CORRECTION FACTOR (dB/m)
1	5150.00	66.7 PK	74.0	-7.3	1.00 V	237	60.50	6.20
2	5150.00	52.4 AV	54.0	-1.6	1.00 V	237	46.20	6.20
3	*5230.00	112.1 PK			1.00 V	30	72.50	39.60
4	*5230.00	102.6 AV			1.00 V	30	63.00	39.60
5	#10460.00	59.6 PK	74.0	-14.4	1.14 V	34	41.80	17.80
6	#10460.00	47.0 AV	54.0	-7.0	1.14 V	34	29.20	17.80

REMARKS:

1. Emission Level(dBuV/m) = Raw Value(dBuV) + Correction Factor(dB/m)
2. Correction Factor(dB/m) = Antenna Factor(dB/m) + Cable Factor(dB)
3. The other emission levels were very low against the limit.
4. Margin value = Emission Level – Limit value
5. " * ": Fundamental frequency.
6. " # ": The radiated frequency is out of the restricted band.

CHANNEL	TX Channel 151	DETECTOR FUNCTION	Peak (PK)
FREQUENCY RANGE	1GHz ~ 40GHz		Average (AV)

ANTENNA POLARITY & TEST DISTANCE: HORIZONTAL AT 3 M

NO.	FREQ. (MHz)	EMISSION LEVEL (dBuV/m)	LIMIT (dBuV/m)	MARGIN (dB)	ANTENNA HEIGHT (m)	TABLE ANGLE (Degree)	RAW VALUE (dBuV)	CORRECTION FACTOR (dB/m)
1	#5714.90	69.1 PK	74.0	-4.9	1.41 H	30	61.90	7.20
2	#5714.90	52.2 AV	54.0	-1.8	1.41 H	30	45.00	7.20
3	#5722.90	69.8 PK	78.2	-8.4	1.39 H	41	62.60	7.20
4	#5725.00	55.9 PK	78.2	-22.3	1.45 H	32	48.70	7.20
5	*5755.00	103.9 PK			1.47 H	276	63.40	40.50
6	*5755.00	94.3 AV			1.47 H	276	53.80	40.50
7	11510.00	58.7 PK	74.0	-15.3	1.06 H	112	40.50	18.20
8	11510.00	46.6 AV	54.0	-7.4	1.06 H	112	28.40	18.20

ANTENNA POLARITY & TEST DISTANCE: VERTICAL AT 3 M

NO.	FREQ. (MHz)	EMISSION LEVEL (dBuV/m)	LIMIT (dBuV/m)	MARGIN (dB)	ANTENNA HEIGHT (m)	TABLE ANGLE (Degree)	RAW VALUE (dBuV)	CORRECTION FACTOR (dB/m)
1	#5714.90	69.8 PK	74.0	-4.2	1.08 V	310	62.60	7.20
2	#5714.90	53.0 AV	54.0	-1.0	1.08 V	310	45.80	7.20
3	#5722.90	76.5 PK	78.2	-1.7	1.07 V	310	69.30	7.20
4	#5725.00	56.5 PK	78.2	-21.7	1.20 V	279	49.30	7.20
5	*5755.00	104.6 PK			1.01 V	24	64.10	40.50
6	*5755.00	95.3 AV			1.01 V	24	54.80	40.50
7	11510.00	58.4 PK	74.0	-15.6	1.10 V	132	40.20	18.20
8	11510.00	46.7 AV	54.0	-7.3	1.10 V	132	28.50	18.20

REMARKS:

1. Emission Level(dBuV/m) = Raw Value(dBuV) + Correction Factor(dB/m)
2. Correction Factor(dB/m) = Antenna Factor(dB/m) + Cable Factor(dB)
3. The other emission levels were very low against the limit.
4. Margin value = Emission Level – Limit value
5. " * ": Fundamental frequency.
6. " # ": The radiated frequency is out of the restricted band.

CHANNEL	TX Channel 159	DETECTOR FUNCTION	Peak (PK)
FREQUENCY RANGE	1GHz ~ 40GHz		Average (AV)

ANTENNA POLARITY & TEST DISTANCE: HORIZONTAL AT 3 M

NO.	FREQ. (MHz)	EMISSION LEVEL (dBuV/m)	LIMIT (dBuV/m)	MARGIN (dB)	ANTENNA HEIGHT (m)	TABLE ANGLE (Degree)	RAW VALUE (dBuV)	CORRECTION FACTOR (dB/m)
1	5120.00	57.9 PK	74.0	-16.1	1.00 H	264	51.70	6.20
2	5120.00	48.9 AV	54.0	-5.1	1.00 H	264	42.70	6.20
3	*5795.00	106.2 PK			1.00 H	35	65.70	40.50
4	*5795.00	97.0 AV			1.00 H	35	56.50	40.50
5	#5850.00	50.4 PK	78.2	-27.8	1.03 H	34	42.90	7.50
6	#5852.10	49.9 PK	78.2	-28.3	1.03 H	35	42.30	7.60
7	#5860.10	63.9 PK	74.0	-10.1	1.04 H	34	56.30	7.60
8	#5860.10	49.4 AV	54.0	-4.6	1.04 H	34	41.80	7.60
9	11590.00	58.7 PK	74.0	-15.3	1.14 H	217	40.40	18.30
10	11590.00	47.6 AV	54.0	-6.4	1.14 H	217	29.30	18.30

ANTENNA POLARITY & TEST DISTANCE: VERTICAL AT 3 M

NO.	FREQ. (MHz)	EMISSION LEVEL (dBuV/m)	LIMIT (dBuV/m)	MARGIN (dB)	ANTENNA HEIGHT (m)	TABLE ANGLE (Degree)	RAW VALUE (dBuV)	CORRECTION FACTOR (dB/m)
1	5120.00	60.6 PK	74.0	-13.4	1.00 V	9	54.40	6.20
2	5120.00	52.6 AV	54.0	-1.4	1.00 V	9	46.40	6.20
3	*5795.00	108.6 PK			1.07 V	28	68.10	40.50
4	*5795.00	99.6 AV			1.07 V	28	59.10	40.50
5	#5850.00	50.4 PK	78.2	-27.8	1.06 V	28	42.90	7.50
6	#5852.10	62.9 PK	78.2	-15.3	1.05 V	22	55.30	7.60
7	#5860.10	60.4 PK	74.0	-13.6	1.00 V	14	52.80	7.60
8	#5860.10	48.3 AV	54.0	-5.7	1.00 V	14	40.70	7.60
9	11590.00	58.4 PK	74.0	-15.6	1.02 V	85	40.10	18.30
10	11590.00	46.7 AV	54.0	-7.3	1.02 V	85	28.40	18.30

REMARKS:

1. Emission Level(dBuV/m) = Raw Value(dBuV) + Correction Factor(dB/m)
2. Correction Factor(dB/m) = Antenna Factor(dB/m) + Cable Factor(dB)
3. The other emission levels were very low against the limit.
4. Margin value = Emission Level – Limit value
5. " * ": Fundamental frequency.
6. " # ": The radiated frequency is out of the restricted band.

Test Mode A2 – PIFA Antenna: 1TX

802.11a

CHANNEL	TX Channel 36	DETECTOR FUNCTION	Peak (PK)
FREQUENCY RANGE	1GHz ~ 40GHz		Average (AV)

ANTENNA POLARITY & TEST DISTANCE: HORIZONTAL AT 3 M

NO.	FREQ. (MHz)	EMISSION LEVEL (dBuV/m)	LIMIT (dBuV/m)	MARGIN (dB)	ANTENNA HEIGHT (m)	TABLE ANGLE (Degree)	RAW VALUE (dBuV)	CORRECTION FACTOR (dB/m)
1	5150.00	62.8 PK	74.0	-11.2	1.70 H	177	56.60	6.20
2	5150.00	47.7 AV	54.0	-6.3	1.70 H	177	41.50	6.20
3	*5180.00	103.9 PK			1.60 H	175	64.40	39.50
4	*5180.00	93.5 AV			1.60 H	175	54.00	39.50
5	#10360.00	59.1 PK	74.0	-14.9	1.52 H	97	42.10	17.00
6	#10360.00	45.5 AV	54.0	-8.5	1.52 H	97	28.50	17.00

ANTENNA POLARITY & TEST DISTANCE: VERTICAL AT 3 M

NO.	FREQ. (MHz)	EMISSION LEVEL (dBuV/m)	LIMIT (dBuV/m)	MARGIN (dB)	ANTENNA HEIGHT (m)	TABLE ANGLE (Degree)	RAW VALUE (dBuV)	CORRECTION FACTOR (dB/m)
1	5150.00	69.8 PK	74.0	-4.2	1.00 V	127	63.60	6.20
2	5150.00	52.9 AV	54.0	-1.1	1.00 V	127	46.70	6.20
3	*5180.00	109.2 PK			1.00 V	129	69.70	39.50
4	*5180.00	98.8 AV			1.00 V	129	59.30	39.50
5	#10360.00	57.7 PK	74.0	-16.3	1.08 V	229	40.70	17.00
6	#10360.00	46.2 AV	54.0	-7.8	1.08 V	229	29.20	17.00

REMARKS:

1. Emission Level(dBuV/m) = Raw Value(dBuV) + Correction Factor(dB/m)
2. Correction Factor(dB/m) = Antenna Factor(dB/m) + Cable Factor(dB)
3. The other emission levels were very low against the limit.
4. Margin value = Emission Level – Limit value
5. " * ": Fundamental frequency.
6. " # ": The radiated frequency is out of the restricted band.



CHANNEL	TX Channel 40	DETECTOR FUNCTION	Peak (PK)
FREQUENCY RANGE	1GHz ~ 40GHz		Average (AV)

ANTENNA POLARITY & TEST DISTANCE: HORIZONTAL AT 3 M

NO.	FREQ. (MHz)	EMISSION LEVEL (dBuV/m)	LIMIT (dBuV/m)	MARGIN (dB)	ANTENNA HEIGHT (m)	TABLE ANGLE (Degree)	RAW VALUE (dBuV)	CORRECTION FACTOR (dB/m)
1	*5200.00	104.8 PK			1.43 H	329	65.20	39.60
2	*5200.00	94.3 AV			1.43 H	329	54.70	39.60
3	#10400.00	57.8 PK	74.0	-16.2	1.26 H	81	40.80	17.00
4	#10400.00	45.1 AV	54.0	-8.9	1.26 H	81	28.10	17.00

ANTENNA POLARITY & TEST DISTANCE: VERTICAL AT 3 M

NO.	FREQ. (MHz)	EMISSION LEVEL (dBuV/m)	LIMIT (dBuV/m)	MARGIN (dB)	ANTENNA HEIGHT (m)	TABLE ANGLE (Degree)	RAW VALUE (dBuV)	CORRECTION FACTOR (dB/m)
1	*5200.00	111.0 PK			1.05 V	113	71.40	39.60
2	*5200.00	100.0 AV			1.05 V	113	60.40	39.60
3	#10400.00	60.4 PK	74.0	-13.6	1.02 V	167	43.40	17.00
4	#10400.00	48.2 AV	54.0	-5.8	1.02 V	167	31.20	17.00

REMARKS:

1. Emission Level(dBuV/m) = Raw Value(dBuV) + Correction Factor(dB/m)
2. Correction Factor(dB/m) = Antenna Factor(dB/m) + Cable Factor(dB)
3. The other emission levels were very low against the limit.
4. Margin value = Emission Level – Limit value
5. " * ": Fundamental frequency.
6. " # ": The radiated frequency is out of the restricted band.



CHANNEL	TX Channel 48	DETECTOR FUNCTION	Peak (PK)
FREQUENCY RANGE	1GHz ~ 40GHz		Average (AV)

ANTENNA POLARITY & TEST DISTANCE: HORIZONTAL AT 3 M

NO.	FREQ. (MHz)	EMISSION LEVEL (dBuV/m)	LIMIT (dBuV/m)	MARGIN (dB)	ANTENNA HEIGHT (m)	TABLE ANGLE (Degree)	RAW VALUE (dBuV)	CORRECTION FACTOR (dB/m)
1	*5240.00	105.3 PK			1.02 H	178	65.70	39.60
2	*5240.00	94.8 AV			1.02 H	178	55.20	39.60
3	5350.00	57.8 PK	74.0	-16.2	1.08 H	172	51.40	6.40
4	5350.00	45.0 AV	54.0	-9.0	1.08 H	172	38.60	6.40
5	#10480.00	58.0 PK	74.0	-16.0	1.11 H	124	40.00	18.00
6	#10480.00	45.9 AV	54.0	-8.1	1.11 H	124	27.90	18.00

ANTENNA POLARITY & TEST DISTANCE: VERTICAL AT 3 M

NO.	FREQ. (MHz)	EMISSION LEVEL (dBuV/m)	LIMIT (dBuV/m)	MARGIN (dB)	ANTENNA HEIGHT (m)	TABLE ANGLE (Degree)	RAW VALUE (dBuV)	CORRECTION FACTOR (dB/m)
1	*5240.00	107.8 PK			1.00 V	138	68.20	39.60
2	*5240.00	98.8 AV			1.00 V	138	59.20	39.60
3	5350.00	58.1 PK	74.0	-15.9	1.08 V	123	51.70	6.40
4	5350.00	45.1 AV	54.0	-8.9	1.08 V	123	38.70	6.40
5	#10480.00	60.0 PK	74.0	-14.0	1.22 V	148	42.00	18.00
6	#10480.00	46.9 AV	54.0	-7.1	1.22 V	148	28.90	18.00

REMARKS:

1. Emission Level(dBuV/m) = Raw Value(dBuV) + Correction Factor(dB/m)
2. Correction Factor(dB/m) = Antenna Factor(dB/m) + Cable Factor(dB)
3. The other emission levels were very low against the limit.
4. Margin value = Emission Level – Limit value
5. " * ": Fundamental frequency.
6. " # ": The radiated frequency is out of the restricted band.

CHANNEL	TX Channel 149	DETECTOR FUNCTION	Peak (PK)
FREQUENCY RANGE	1GHz ~ 40GHz		Average (AV)

ANTENNA POLARITY & TEST DISTANCE: HORIZONTAL AT 3 M

NO.	FREQ. (MHz)	EMISSION LEVEL (dBuV/m)	LIMIT (dBuV/m)	MARGIN (dB)	ANTENNA HEIGHT (m)	TABLE ANGLE (Degree)	RAW VALUE (dBuV)	CORRECTION FACTOR (dB/m)
1	#5714.00	58.1 PK	74.0	-15.9	1.64 H	145	50.90	7.20
2	#5714.00	46.7 AV	54.0	-7.3	1.64 H	145	39.50	7.20
3	#5722.00	71.6 PK	78.2	-6.6	1.75 H	189	64.40	7.20
4	#5725.00	65.4 PK	78.2	-12.8	1.75 H	189	58.20	7.20
5	*5745.00	103.1 PK			1.67 H	190	62.70	40.40
6	*5745.00	93.0 AV			1.67 H	190	52.60	40.40
7	11490.00	59.8 PK	74.0	-14.2	1.23 H	211	41.50	18.30
8	11490.00	46.8 AV	54.0	-7.2	1.23 H	211	28.50	18.30

ANTENNA POLARITY & TEST DISTANCE: VERTICAL AT 3 M

NO.	FREQ. (MHz)	EMISSION LEVEL (dBuV/m)	LIMIT (dBuV/m)	MARGIN (dB)	ANTENNA HEIGHT (m)	TABLE ANGLE (Degree)	RAW VALUE (dBuV)	CORRECTION FACTOR (dB/m)
1	#5714.00	61.3 PK	74.0	-12.7	1.62 V	79	54.10	7.20
2	#5714.00	50.1 AV	54.0	-3.9	1.62 V	79	42.90	7.20
3	#5722.00	77.0 PK	78.2	-1.2	1.58 V	75	69.80	7.20
4	#5725.00	64.8 PK	78.2	-13.4	1.66 V	74	57.60	7.20
5	*5745.00	107.3 PK			1.50 V	77	66.90	40.40
6	*5745.00	96.8 AV			1.50 V	77	56.40	40.40
7	11490.00	59.3 PK	74.0	-14.7	1.44 V	77	41.00	18.30
8	11490.00	47.5 AV	54.0	-6.5	1.44 V	77	29.20	18.30

REMARKS:

1. Emission Level(dBuV/m) = Raw Value(dBuV) + Correction Factor(dB/m)
2. Correction Factor(dB/m) = Antenna Factor(dB/m) + Cable Factor(dB)
3. The other emission levels were very low against the limit.
4. Margin value = Emission Level – Limit value
5. " * ": Fundamental frequency.
6. " # ": The radiated frequency is out of the restricted band.

CHANNEL	TX Channel 157	DETECTOR FUNCTION	Peak (PK)
FREQUENCY RANGE	1GHz ~ 40GHz		Average (AV)

ANTENNA POLARITY & TEST DISTANCE: HORIZONTAL AT 3 M

NO.	FREQ. (MHz)	EMISSION LEVEL (dBuV/m)	LIMIT (dBuV/m)	MARGIN (dB)	ANTENNA HEIGHT (m)	TABLE ANGLE (Degree)	RAW VALUE (dBuV)	CORRECTION FACTOR (dB/m)
1	*5785.00	105.9 PK			1.55 H	188	65.40	40.50
2	*5785.00	95.5 AV			1.55 H	188	55.00	40.50
3	11570.00	60.2 PK	74.0	-13.8	1.06 H	136	42.00	18.20
4	11570.00	47.0 AV	54.0	-7.0	1.06 H	136	28.80	18.20

ANTENNA POLARITY & TEST DISTANCE: VERTICAL AT 3 M

NO.	FREQ. (MHz)	EMISSION LEVEL (dBuV/m)	LIMIT (dBuV/m)	MARGIN (dB)	ANTENNA HEIGHT (m)	TABLE ANGLE (Degree)	RAW VALUE (dBuV)	CORRECTION FACTOR (dB/m)
1	*5785.00	110.8 PK			1.07 V	106	70.30	40.50
2	*5785.00	99.8 AV			1.07 V	106	59.30	40.50
3	11570.00	60.6 PK	74.0	-13.4	1.26 V	336	42.40	18.20
4	11570.00	47.4 AV	54.0	-6.6	1.26 V	336	29.20	18.20

REMARKS:

1. Emission Level(dBuV/m) = Raw Value(dBuV) + Correction Factor(dB/m)
2. Correction Factor(dB/m) = Antenna Factor(dB/m) + Cable Factor(dB)
3. The other emission levels were very low against the limit.
4. Margin value = Emission Level – Limit value
5. " * ": Fundamental frequency.

CHANNEL	TX Channel 165	DETECTOR FUNCTION	Peak (PK)
FREQUENCY RANGE	1GHz ~ 40GHz		Average (AV)

ANTENNA POLARITY & TEST DISTANCE: HORIZONTAL AT 3 M

NO.	FREQ. (MHz)	EMISSION LEVEL (dBuV/m)	LIMIT (dBuV/m)	MARGIN (dB)	ANTENNA HEIGHT (m)	TABLE ANGLE (Degree)	RAW VALUE (dBuV)	CORRECTION FACTOR (dB/m)
1	*5825.00	106.1 PK			1.65 H	189	65.60	40.50
2	*5825.00	95.3 AV			1.65 H	189	54.80	40.50
3	#5850.00	54.5 PK	78.2	-23.7	1.43 H	143	47.00	7.50
4	#5853.00	63.1 PK	78.2	-15.1	1.43 H	130	55.50	7.60
5	#5861.00	63.0 PK	74.0	-11.0	1.58 H	139	55.40	7.60
6	#5861.00	48.1 AV	54.0	-5.9	1.58 H	139	40.50	7.60
7	11650.00	59.9 PK	74.0	-14.1	1.10 H	96	41.20	18.70
8	11650.00	46.9 AV	54.0	-7.1	1.10 H	96	28.20	18.70

ANTENNA POLARITY & TEST DISTANCE: VERTICAL AT 3 M

NO.	FREQ. (MHz)	EMISSION LEVEL (dBuV/m)	LIMIT (dBuV/m)	MARGIN (dB)	ANTENNA HEIGHT (m)	TABLE ANGLE (Degree)	RAW VALUE (dBuV)	CORRECTION FACTOR (dB/m)
1	*5825.00	109.9 PK			1.47 V	94	69.40	40.50
2	*5825.00	99.8 AV			1.47 V	94	59.30	40.50
3	#5850.00	64.2 PK	78.2	-14.0	1.46 V	95	56.70	7.50
4	#5855.00	76.3 PK	78.2	-1.9	1.46 V	95	68.70	7.60
5	#5861.00	68.0 PK	74.0	-6.0	1.38 V	95	60.40	7.60
6	#5861.00	50.6 AV	54.0	-3.4	1.38 V	95	43.00	7.60
7	11650.00	60.2 PK	74.0	-13.8	1.23 V	222	41.50	18.70
8	11650.00	47.3 AV	54.0	-6.7	1.23 V	222	28.60	18.70

REMARKS:

1. Emission Level(dBuV/m) = Raw Value(dBuV) + Correction Factor(dB/m)
2. Correction Factor(dB/m) = Antenna Factor(dB/m) + Cable Factor(dB)
3. The other emission levels were very low against the limit.
4. Margin value = Emission Level – Limit value
5. " * ": Fundamental frequency.
6. " # ": The radiated frequency is out of the restricted band.

Test Mode B1 – Dipole Antenna: 3TX

802.11a

CHANNEL	TX Channel 36	DETECTOR FUNCTION	Peak (PK)
FREQUENCY RANGE	1GHz ~ 40GHz		Average (AV)

ANTENNA POLARITY & TEST DISTANCE: HORIZONTAL AT 3 M

NO.	FREQ. (MHz)	EMISSION LEVEL (dBuV/m)	LIMIT (dBuV/m)	MARGIN (dB)	ANTENNA HEIGHT (m)	TABLE ANGLE (Degree)	RAW VALUE (dBuV)	CORRECTION FACTOR (dB/m)
1	5150.00	60.8 PK	74.0	-13.2	1.11 H	27	54.80	6.00
2	5150.00	46.8 AV	54.0	-7.2	1.11 H	27	40.80	6.00
3	*5180.00	103.2 PK			1.11 H	27	63.70	39.50
4	*5180.00	93.3 AV			1.11 H	27	53.80	39.50
5	#10360.00	60.8 PK	74.0	-13.2	1.29 H	143	42.40	18.40
6	#10360.00	47.8 AV	54.0	-6.2	1.29 H	143	29.40	18.40

ANTENNA POLARITY & TEST DISTANCE: VERTICAL AT 3 M

NO.	FREQ. (MHz)	EMISSION LEVEL (dBuV/m)	LIMIT (dBuV/m)	MARGIN (dB)	ANTENNA HEIGHT (m)	TABLE ANGLE (Degree)	RAW VALUE (dBuV)	CORRECTION FACTOR (dB/m)
1	5150.00	72.6 PK	74.0	-1.4	1.65 V	310	66.60	6.00
2	5150.00	52.8 AV	54.0	-1.2	1.65 V	310	46.80	6.00
3	*5180.00	115.0 PK			1.91 V	53	75.50	39.50
4	*5180.00	105.9 AV			1.91 V	53	66.40	39.50
5	#10360.00	61.0 PK	74.0	-13.0	1.56 V	259	42.60	18.40
6	#10360.00	47.9 AV	54.0	-6.1	1.56 V	259	29.50	18.40

REMARKS:

1. Emission Level(dBuV/m) = Raw Value(dBuV) + Correction Factor(dB/m)
2. Correction Factor(dB/m) = Antenna Factor(dB/m) + Cable Factor(dB)
3. The other emission levels were very low against the limit.
4. Margin value = Emission Level – Limit value
5. " * ": Fundamental frequency.
6. " # ": The radiated frequency is out of the restricted band.



CHANNEL	TX Channel 40	DETECTOR FUNCTION	Peak (PK)
FREQUENCY RANGE	1GHz ~ 40GHz		Average (AV)

ANTENNA POLARITY & TEST DISTANCE: HORIZONTAL AT 3 M

NO.	FREQ. (MHz)	EMISSION LEVEL (dBuV/m)	LIMIT (dBuV/m)	MARGIN (dB)	ANTENNA HEIGHT (m)	TABLE ANGLE (Degree)	RAW VALUE (dBuV)	CORRECTION FACTOR (dB/m)
1	5150.00	59.8 PK	74.0	-14.2	1.47 H	159	53.80	6.00
2	5150.00	46.5 AV	54.0	-7.5	1.47 H	159	40.50	6.00
3	*5200.00	105.2 PK			1.51 H	166	65.60	39.60
4	*5200.00	95.0 AV			1.51 H	166	55.40	39.60
5	#10400.00	60.9 PK	74.0	-13.1	1.26 H	177	42.40	18.50
6	#10400.00	47.8 AV	54.0	-6.2	1.26 H	177	29.30	18.50

ANTENNA POLARITY & TEST DISTANCE: VERTICAL AT 3 M

NO.	FREQ. (MHz)	EMISSION LEVEL (dBuV/m)	LIMIT (dBuV/m)	MARGIN (dB)	ANTENNA HEIGHT (m)	TABLE ANGLE (Degree)	RAW VALUE (dBuV)	CORRECTION FACTOR (dB/m)
1	5150.00	69.1 PK	74.0	-4.9	1.67 V	205	63.10	6.00
2	5150.00	52.1 AV	54.0	-1.9	1.67 V	205	46.10	6.00
3	*5200.00	118.3 PK			1.98 V	55	78.70	39.60
4	*5200.00	107.6 AV			1.98 V	55	68.00	39.60
5	#10400.00	61.5 PK	74.0	-12.5	1.60 V	266	43.00	18.50
6	#10400.00	48.5 AV	54.0	-5.5	1.60 V	266	30.00	18.50

REMARKS:

1. Emission Level(dBuV/m) = Raw Value(dBuV) + Correction Factor(dB/m)
2. Correction Factor(dB/m) = Antenna Factor(dB/m) + Cable Factor(dB)
3. The other emission levels were very low against the limit.
4. Margin value = Emission Level – Limit value
5. " * ": Fundamental frequency.
6. " # ": The radiated frequency is out of the restricted band.

CHANNEL	TX Channel 48	DETECTOR FUNCTION	Peak (PK)
FREQUENCY RANGE	1GHz ~ 40GHz		Average (AV)

ANTENNA POLARITY & TEST DISTANCE: HORIZONTAL AT 3 M

NO.	FREQ. (MHz)	EMISSION LEVEL (dBuV/m)	LIMIT (dBuV/m)	MARGIN (dB)	ANTENNA HEIGHT (m)	TABLE ANGLE (Degree)	RAW VALUE (dBuV)	CORRECTION FACTOR (dB/m)
1	*5240.00	107.0 PK			1.15 H	69	67.40	39.60
2	*5240.00	96.6 AV			1.15 H	69	57.00	39.60
3	5350.00	60.1 PK	74.0	-13.9	1.20 H	179	54.00	6.10
4	5350.00	46.7 AV	54.0	-7.3	1.20 H	179	40.60	6.10
5	#10480.00	61.0 PK	74.0	-13.0	1.33 H	211	42.00	19.00
6	#10480.00	48.1 AV	54.0	-5.9	1.33 H	211	29.10	19.00

ANTENNA POLARITY & TEST DISTANCE: VERTICAL AT 3 M

NO.	FREQ. (MHz)	EMISSION LEVEL (dBuV/m)	LIMIT (dBuV/m)	MARGIN (dB)	ANTENNA HEIGHT (m)	TABLE ANGLE (Degree)	RAW VALUE (dBuV)	CORRECTION FACTOR (dB/m)
1	*5240.00	118.0 PK			1.92 V	270	78.40	39.60
2	*5240.00	107.5 AV			1.92 V	270	67.90	39.60
3	5440.00	62.8 PK	74.0	-11.2	1.70 V	0	56.50	6.30
4	5440.00	49.6 AV	54.0	-4.4	1.70 V	0	43.30	6.30
5	#10480.00	61.9 PK	74.0	-12.1	2.07 V	211	42.90	19.00
6	#10480.00	48.5 AV	54.0	-5.5	2.07 V	211	29.50	19.00

REMARKS:

1. Emission Level(dBuV/m) = Raw Value(dBuV) + Correction Factor(dB/m)
2. Correction Factor(dB/m) = Antenna Factor(dB/m) + Cable Factor(dB)
3. The other emission levels were very low against the limit.
4. Margin value = Emission Level – Limit value
5. " * ": Fundamental frequency.
6. " # ": The radiated frequency is out of the restricted band.

CHANNEL	TX Channel 149	DETECTOR FUNCTION	Peak (PK)
FREQUENCY RANGE	1GHz ~ 40GHz		Average (AV)

ANTENNA POLARITY & TEST DISTANCE: HORIZONTAL AT 3 M

NO.	FREQ. (MHz)	EMISSION LEVEL (dBuV/m)	LIMIT (dBuV/m)	MARGIN (dB)	ANTENNA HEIGHT (m)	TABLE ANGLE (Degree)	RAW VALUE (dBuV)	CORRECTION FACTOR (dB/m)
1	#5714.00	58.2 PK	74.0	-15.8	1.10 H	58	51.40	6.80
2	#5714.00	47.0 AV	54.0	-7.0	1.10 H	58	40.20	6.80
3	#5722.00	64.4 PK	78.2	-13.8	1.13 H	200	57.60	6.80
4	#5725.00	57.3 PK	78.2	-20.9	1.13 H	200	50.50	6.80
5	*5745.00	101.6 PK			1.06 H	263	61.20	40.40
6	*5745.00	91.5 AV			1.06 H	263	51.10	40.40
7	11490.00	59.5 PK	74.0	-14.5	1.20 H	249	41.10	18.40
8	11490.00	46.7 AV	54.0	-7.3	1.20 H	249	28.30	18.40

ANTENNA POLARITY & TEST DISTANCE: VERTICAL AT 3 M

NO.	FREQ. (MHz)	EMISSION LEVEL (dBuV/m)	LIMIT (dBuV/m)	MARGIN (dB)	ANTENNA HEIGHT (m)	TABLE ANGLE (Degree)	RAW VALUE (dBuV)	CORRECTION FACTOR (dB/m)
1	#5714.00	67.8 PK	74.0	-6.2	1.85 V	276	61.00	6.80
2	#5714.00	50.0 AV	54.0	-4.0	1.85 V	276	43.20	6.80
3	#5722.00	76.3 PK	78.2	-1.9	1.94 V	266	69.50	6.80
4	#5725.00	63.7 PK	78.2	-14.5	1.94 V	264	56.90	6.80
5	*5745.00	114.9 PK			1.72 V	46	74.50	40.40
6	*5745.00	103.9 AV			1.72 V	46	63.50	40.40
7	11490.00	60.3 PK	74.0	-13.7	1.65 V	240	41.90	18.40
8	11490.00	47.3 AV	54.0	-6.7	1.65 V	240	28.90	18.40

REMARKS:

1. Emission Level(dBuV/m) = Raw Value(dBuV) + Correction Factor(dB/m)
2. Correction Factor(dB/m) = Antenna Factor(dB/m) + Cable Factor(dB)
3. The other emission levels were very low against the limit.
4. Margin value = Emission Level – Limit value
5. " * ": Fundamental frequency.
6. " # ": The radiated frequency is out of the restricted band.



CHANNEL	TX Channel 157	DETECTOR FUNCTION	Peak (PK)
FREQUENCY RANGE	1GHz ~ 40GHz		Average (AV)

ANTENNA POLARITY & TEST DISTANCE: HORIZONTAL AT 3 M

NO.	FREQ. (MHz)	EMISSION LEVEL (dBuV/m)	LIMIT (dBuV/m)	MARGIN (dB)	ANTENNA HEIGHT (m)	TABLE ANGLE (Degree)	RAW VALUE (dBuV)	CORRECTION FACTOR (dB/m)
1	5080.00	58.7 PK	74.0	-15.3	1.00 H	200	52.90	5.80
2	5080.00	47.7 AV	54.0	-6.3	1.00 H	200	41.90	5.80
3	5440.00	58.9 PK	74.0	-15.1	1.20 H	95	52.60	6.30
4	5440.00	47.4 AV	54.0	-6.6	1.20 H	95	41.10	6.30
5	*5785.00	106.2 PK			1.12 H	269	65.70	40.50
6	*5785.00	96.0 AV			1.12 H	269	55.50	40.50
7	11570.00	60.4 PK	74.0	-13.6	1.09 H	279	42.00	18.40
8	11570.00	47.3 AV	54.0	-6.7	1.09 H	279	28.90	18.40

ANTENNA POLARITY & TEST DISTANCE: VERTICAL AT 3 M

NO.	FREQ. (MHz)	EMISSION LEVEL (dBuV/m)	LIMIT (dBuV/m)	MARGIN (dB)	ANTENNA HEIGHT (m)	TABLE ANGLE (Degree)	RAW VALUE (dBuV)	CORRECTION FACTOR (dB/m)
1	5080.00	61.3 PK	74.0	-12.7	1.79 V	105	55.50	5.80
2	5080.00	51.8 AV	54.0	-2.2	1.79 V	105	46.00	5.80
3	5440.00	63.7 PK	74.0	-10.3	1.51 V	280	57.40	6.30
4	5440.00	52.7 AV	54.0	-1.3	1.51 V	280	46.40	6.30
5	*5785.00	114.5 PK			1.80 V	64	74.00	40.50
6	*5785.00	105.0 AV			1.80 V	64	64.50	40.50
7	11570.00	61.0 PK	74.0	-13.0	1.50 V	321	42.60	18.40
8	11570.00	47.9 AV	54.0	-6.1	1.50 V	321	29.50	18.40

REMARKS:

1. Emission Level(dBuV/m) = Raw Value(dBuV) + Correction Factor(dB/m)
2. Correction Factor(dB/m) = Antenna Factor(dB/m) + Cable Factor(dB)
3. The other emission levels were very low against the limit.
4. Margin value = Emission Level – Limit value
5. " * ": Fundamental frequency.

CHANNEL	TX Channel 165	DETECTOR FUNCTION	Peak (PK)
FREQUENCY RANGE	1GHz ~ 40GHz		Average (AV)

ANTENNA POLARITY & TEST DISTANCE: HORIZONTAL AT 3 M

NO.	FREQ. (MHz)	EMISSION LEVEL (dBuV/m)	LIMIT (dBuV/m)	MARGIN (dB)	ANTENNA HEIGHT (m)	TABLE ANGLE (Degree)	RAW VALUE (dBuV)	CORRECTION FACTOR (dB/m)
1	*5825.00	106.0 PK			1.02 H	277	65.50	40.50
2	*5825.00	95.8 AV			1.02 H	277	55.30	40.50
3	#5850.00	60.4 PK	78.2	-17.8	1.20 H	189	53.50	6.90
4	#5853.00	63.6 PK	78.2	-14.6	1.20 H	189	56.60	7.00
5	#5861.00	58.5 PK	74.0	-15.5	1.17 H	269	51.50	7.00
6	#5861.00	47.0 AV	54.0	-7.0	1.17 H	269	40.00	7.00
7	11650.00	60.9 PK	74.0	-13.1	1.17 H	195	42.00	18.90
8	11650.00	48.1 AV	54.0	-5.9	1.17 H	195	29.20	18.90

ANTENNA POLARITY & TEST DISTANCE: VERTICAL AT 3 M

NO.	FREQ. (MHz)	EMISSION LEVEL (dBuV/m)	LIMIT (dBuV/m)	MARGIN (dB)	ANTENNA HEIGHT (m)	TABLE ANGLE (Degree)	RAW VALUE (dBuV)	CORRECTION FACTOR (dB/m)
1	*5825.00	116.5 PK			1.75 V	49	76.00	40.50
2	*5825.00	107.0 AV			1.75 V	49	66.50	40.50
3	#5850.00	64.2 PK	78.2	-14.0	1.85 V	294	57.30	6.90
4	#5853.00	76.3 PK	78.2	-1.9	1.87 V	296	69.30	7.00
5	#5861.00	68.4 PK	74.0	-5.6	1.87 V	287	61.40	7.00
6	#5861.00	50.7 AV	54.0	-3.3	1.87 V	287	43.70	7.00
7	11650.00	61.1 PK	74.0	-12.9	1.57 V	202	42.20	18.90
8	11650.00	48.5 AV	54.0	-5.5	1.57 V	202	29.60	18.90

REMARKS:

1. Emission Level(dBuV/m) = Raw Value(dBuV) + Correction Factor(dB/m)
2. Correction Factor(dB/m) = Antenna Factor(dB/m) + Cable Factor(dB)
3. The other emission levels were very low against the limit.
4. Margin value = Emission Level – Limit value
5. " * ": Fundamental frequency.
6. " # ": The radiated frequency is out of the restricted band.

802.11n (HT20)

CHANNEL	TX Channel 36	DETECTOR FUNCTION	Peak (PK)
FREQUENCY RANGE	1GHz ~ 40GHz		Average (AV)

ANTENNA POLARITY & TEST DISTANCE: HORIZONTAL AT 3 M								
NO.	FREQ. (MHz)	EMISSION LEVEL (dBuV/m)	LIMIT (dBuV/m)	MARGIN (dB)	ANTENNA HEIGHT (m)	TABLE ANGLE (Degree)	RAW VALUE (dBuV)	CORRECTION FACTOR (dB/m)
1	5150.00	59.2 PK	74.0	-14.8	1.31 H	160	53.20	6.00
2	5150.00	46.5 AV	54.0	-7.5	1.31 H	160	40.50	6.00
3	*5180.00	101.6 PK			1.26 H	106	62.10	39.50
4	*5180.00	91.8 AV			1.26 H	106	52.30	39.50
5	#10360.00	60.1 PK	74.0	-13.9	1.16 H	303	41.70	18.40
6	#10360.00	47.1 AV	54.0	-6.9	1.16 H	303	28.70	18.40

ANTENNA POLARITY & TEST DISTANCE: VERTICAL AT 3 M								
NO.	FREQ. (MHz)	EMISSION LEVEL (dBuV/m)	LIMIT (dBuV/m)	MARGIN (dB)	ANTENNA HEIGHT (m)	TABLE ANGLE (Degree)	RAW VALUE (dBuV)	CORRECTION FACTOR (dB/m)
1	5150.00	72.6 PK	74.0	-1.4	1.68 V	173	66.60	6.00
2	5150.00	51.7 AV	54.0	-2.3	1.68 V	173	45.70	6.00
3	*5180.00	114.6 PK			1.72 V	106	75.10	39.50
4	*5180.00	104.7 AV			1.72 V	106	65.20	39.50
5	#10360.00	60.3 PK	74.0	-13.7	1.66 V	200	41.90	18.40
6	#10360.00	47.4 AV	54.0	-6.6	1.66 V	200	29.00	18.40

REMARKS:

1. Emission Level(dBuV/m) = Raw Value(dBuV) + Correction Factor(dB/m)
2. Correction Factor(dB/m) = Antenna Factor(dB/m) + Cable Factor(dB)
3. The other emission levels were very low against the limit.
4. Margin value = Emission Level – Limit value
5. " * ": Fundamental frequency.
6. " # ": The radiated frequency is out of the restricted band.

CHANNEL	TX Channel 40	DETECTOR FUNCTION	Peak (PK)
FREQUENCY RANGE	1GHz ~ 40GHz		Average (AV)

ANTENNA POLARITY & TEST DISTANCE: HORIZONTAL AT 3 M

NO.	FREQ. (MHz)	EMISSION LEVEL (dBuV/m)	LIMIT (dBuV/m)	MARGIN (dB)	ANTENNA HEIGHT (m)	TABLE ANGLE (Degree)	RAW VALUE (dBuV)	CORRECTION FACTOR (dB/m)
1	5150.00	56.8 PK	74.0	-17.2	1.10 H	33	50.80	6.00
2	5150.00	45.6 AV	54.0	-8.4	1.10 H	33	39.60	6.00
3	*5200.00	102.9 PK			1.00 H	19	63.30	39.60
4	*5200.00	93.2 AV			1.00 H	19	53.60	39.60
5	#10400.00	59.8 PK	74.0	-14.2	1.29 H	100	41.30	18.50
6	#10400.00	46.9 AV	54.0	-7.1	1.29 H	100	28.40	18.50

ANTENNA POLARITY & TEST DISTANCE: VERTICAL AT 3 M

NO.	FREQ. (MHz)	EMISSION LEVEL (dBuV/m)	LIMIT (dBuV/m)	MARGIN (dB)	ANTENNA HEIGHT (m)	TABLE ANGLE (Degree)	RAW VALUE (dBuV)	CORRECTION FACTOR (dB/m)
1	5150.00	72.1 PK	74.0	-1.9	1.91 V	50	66.10	6.00
2	5150.00	51.2 AV	54.0	-2.8	1.91 V	50	45.20	6.00
3	*5200.00	117.3 PK			1.74 V	278	77.70	39.60
4	*5200.00	107.2 AV			1.74 V	278	67.60	39.60
5	#10400.00	60.4 PK	74.0	-13.6	1.60 V	178	41.90	18.50
6	#10400.00	47.4 AV	54.0	-6.6	1.60 V	178	28.90	18.50

REMARKS:

1. Emission Level(dBuV/m) = Raw Value(dBuV) + Correction Factor(dB/m)
2. Correction Factor(dB/m) = Antenna Factor(dB/m) + Cable Factor(dB)
3. The other emission levels were very low against the limit.
4. Margin value = Emission Level – Limit value
5. " * ": Fundamental frequency.
6. " # ": The radiated frequency is out of the restricted band.

CHANNEL	TX Channel 48	DETECTOR FUNCTION	Peak (PK)
FREQUENCY RANGE	1GHz ~ 40GHz		Average (AV)

ANTENNA POLARITY & TEST DISTANCE: HORIZONTAL AT 3 M

NO.	FREQ. (MHz)	EMISSION LEVEL (dBuV/m)	LIMIT (dBuV/m)	MARGIN (dB)	ANTENNA HEIGHT (m)	TABLE ANGLE (Degree)	RAW VALUE (dBuV)	CORRECTION FACTOR (dB/m)
1	*5240.00	103.8 PK			1.18 H	224	64.20	39.60
2	*5240.00	94.2 AV			1.18 H	224	54.60	39.60
3	5350.00	59.2 PK	74.0	-14.8	1.23 H	244	53.10	6.10
4	5350.00	47.1 AV	54.0	-6.9	1.23 H	244	41.00	6.10
5	#10480.00	61.2 PK	74.0	-12.8	1.18 H	210	42.20	19.00
6	#10480.00	48.1 AV	54.0	-5.9	1.18 H	210	29.10	19.00

ANTENNA POLARITY & TEST DISTANCE: VERTICAL AT 3 M

NO.	FREQ. (MHz)	EMISSION LEVEL (dBuV/m)	LIMIT (dBuV/m)	MARGIN (dB)	ANTENNA HEIGHT (m)	TABLE ANGLE (Degree)	RAW VALUE (dBuV)	CORRECTION FACTOR (dB/m)
1	*5240.00	117.9 PK			1.78 V	82	78.30	39.60
2	*5240.00	107.0 AV			1.78 V	82	67.40	39.60
3	5440.00	61.4 PK	74.0	-12.6	1.82 V	57	55.10	6.30
4	5440.00	50.9 AV	54.0	-3.1	1.82 V	57	44.60	6.30
5	#10480.00	61.7 PK	74.0	-12.3	1.70 V	212	42.70	19.00
6	#10480.00	48.6 AV	54.0	-5.4	1.70 V	212	29.60	19.00

REMARKS:

1. Emission Level(dBuV/m) = Raw Value(dBuV) + Correction Factor(dB/m)
2. Correction Factor(dB/m) = Antenna Factor(dB/m) + Cable Factor(dB)
3. The other emission levels were very low against the limit.
4. Margin value = Emission Level – Limit value
5. " * ": Fundamental frequency.
6. " # ": The radiated frequency is out of the restricted band.



CHANNEL	TX Channel 149	DETECTOR FUNCTION	Peak (PK)
FREQUENCY RANGE	1GHz ~ 40GHz		Average (AV)

ANTENNA POLARITY & TEST DISTANCE: HORIZONTAL AT 3 M

NO.	FREQ. (MHz)	EMISSION LEVEL (dBuV/m)	LIMIT (dBuV/m)	MARGIN (dB)	ANTENNA HEIGHT (m)	TABLE ANGLE (Degree)	RAW VALUE (dBuV)	CORRECTION FACTOR (dB/m)
1	#5714.90	57.8 PK	74.0	-16.2	1.05 H	101	51.00	6.80
2	#5714.90	46.0 AV	54.0	-8.0	1.05 H	101	39.20	6.80
3	#5722.90	62.6 PK	78.2	-15.6	1.25 H	105	55.80	6.80
4	#5725.00	49.9 PK	78.2	-28.3	1.05 H	106	43.10	6.80
5	*5745.00	103.6 PK			1.18 H	97	63.20	40.40
6	*5745.00	93.2 AV			1.18 H	97	52.80	40.40
7	11490.00	58.0 PK	74.0	-16.0	1.07 H	38	39.60	18.40
8	11490.00	45.5 AV	54.0	-8.5	1.07 H	38	27.10	18.40

ANTENNA POLARITY & TEST DISTANCE: VERTICAL AT 3 M

NO.	FREQ. (MHz)	EMISSION LEVEL (dBuV/m)	LIMIT (dBuV/m)	MARGIN (dB)	ANTENNA HEIGHT (m)	TABLE ANGLE (Degree)	RAW VALUE (dBuV)	CORRECTION FACTOR (dB/m)
1	#5714.90	67.2 PK	74.0	-6.8	1.52 V	278	60.40	6.80
2	#5714.90	47.7 AV	54.0	-6.3	1.52 V	278	40.90	6.80
3	#5722.90	77.1 PK	78.2	-1.1	1.42 V	278	70.30	6.80
4	#5725.00	56.9 PK	78.2	-21.3	1.62 V	278	50.10	6.80
5	*5745.00	112.3 PK			1.15 V	278	71.90	40.40
6	*5745.00	102.4 AV			1.15 V	278	62.00	40.40
7	11490.00	57.8 PK	74.0	-16.2	1.30 V	185	39.40	18.40
8	11490.00	45.4 AV	54.0	-8.6	1.30 V	185	27.00	18.40

REMARKS:

1. Emission Level(dBuV/m) = Raw Value(dBuV) + Correction Factor(dB/m)
2. Correction Factor(dB/m) = Antenna Factor(dB/m) + Cable Factor(dB)
3. The other emission levels were very low against the limit.
4. Margin value = Emission Level – Limit value
5. " * ": Fundamental frequency.
6. " # ": The radiated frequency is out of the restricted band.

CHANNEL	TX Channel 157	DETECTOR FUNCTION	Peak (PK)
FREQUENCY RANGE	1GHz ~ 40GHz		Average (AV)

ANTENNA POLARITY & TEST DISTANCE: HORIZONTAL AT 3 M

NO.	FREQ. (MHz)	EMISSION LEVEL (dBuV/m)	LIMIT (dBuV/m)	MARGIN (dB)	ANTENNA HEIGHT (m)	TABLE ANGLE (Degree)	RAW VALUE (dBuV)	CORRECTION FACTOR (dB/m)
1	5440.00	57.9 PK	74.0	-16.1	1.29 H	103	51.60	6.30
2	5440.00	46.3 AV	54.0	-7.7	1.29 H	103	40.00	6.30
3	*5785.00	108.4 PK			1.00 H	101	67.90	40.50
4	*5785.00	98.5 AV			1.00 H	101	58.00	40.50
5	11570.00	58.7 PK	74.0	-15.3	1.20 H	72	40.30	18.40
6	11570.00	46.3 AV	54.0	-7.7	1.20 H	72	27.90	18.40

ANTENNA POLARITY & TEST DISTANCE: VERTICAL AT 3 M

NO.	FREQ. (MHz)	EMISSION LEVEL (dBuV/m)	LIMIT (dBuV/m)	MARGIN (dB)	ANTENNA HEIGHT (m)	TABLE ANGLE (Degree)	RAW VALUE (dBuV)	CORRECTION FACTOR (dB/m)
1	5440.00	61.4 PK	74.0	-12.6	2.07 V	121	55.10	6.30
2	5440.00	52.4 AV	54.0	-1.6	2.07 V	121	46.10	6.30
3	*5785.00	116.0 PK			1.98 V	294	75.50	40.50
4	*5785.00	105.4 AV			1.98 V	294	64.90	40.50
5	11570.00	58.5 PK	74.0	-15.5	1.34 V	184	40.10	18.40
6	11570.00	45.5 AV	54.0	-8.5	1.34 V	184	27.10	18.40

REMARKS:

1. Emission Level(dBuV/m) = Raw Value(dBuV) + Correction Factor(dB/m)
2. Correction Factor(dB/m) = Antenna Factor(dB/m) + Cable Factor(dB)
3. The other emission levels were very low against the limit.
4. Margin value = Emission Level – Limit value
5. " * ": Fundamental frequency.

CHANNEL	TX Channel 165	DETECTOR FUNCTION	Peak (PK)
FREQUENCY RANGE	1GHz ~ 40GHz		Average (AV)

ANTENNA POLARITY & TEST DISTANCE: HORIZONTAL AT 3 M

NO.	FREQ. (MHz)	EMISSION LEVEL (dBuV/m)	LIMIT (dBuV/m)	MARGIN (dB)	ANTENNA HEIGHT (m)	TABLE ANGLE (Degree)	RAW VALUE (dBuV)	CORRECTION FACTOR (dB/m)
1	5400.00	57.7 PK	74.0	-16.3	1.25 H	140	51.40	6.30
2	5400.00	45.7 AV	54.0	-8.3	1.25 H	140	39.40	6.30
3	*5825.00	106.4 PK			1.00 H	102	65.90	40.50
4	*5825.00	96.2 AV			1.00 H	102	55.70	40.50
5	#5852.00	50.2 PK	78.2	-28.0	1.16 H	102	43.20	7.00
6	#5852.10	64.9 PK	78.2	-13.3	1.16 H	102	57.90	7.00
7	#5860.10	58.6 PK	74.0	-15.4	1.29 H	108	51.60	7.00
8	#5860.10	45.6 AV	54.0	-8.4	1.29 H	108	38.60	7.00
9	11650.00	60.0 PK	74.0	-14.0	1.22 H	139	41.10	18.90
10	11650.00	46.6 AV	54.0	-7.4	1.22 H	139	27.70	18.90

ANTENNA POLARITY & TEST DISTANCE: VERTICAL AT 3 M

NO.	FREQ. (MHz)	EMISSION LEVEL (dBuV/m)	LIMIT (dBuV/m)	MARGIN (dB)	ANTENNA HEIGHT (m)	TABLE ANGLE (Degree)	RAW VALUE (dBuV)	CORRECTION FACTOR (dB/m)
1	5400.00	61.8 PK	74.0	-12.2	1.98 V	121	55.50	6.30
2	5400.00	52.2 AV	54.0	-1.8	1.98 V	121	45.90	6.30
3	*5825.00	113.8 PK			1.82 V	292	73.30	40.50
4	*5825.00	104.0 AV			1.82 V	292	63.50	40.50
5	#5850.00	59.5 PK	78.2	-18.7	1.73 V	297	52.60	6.90
6	#5852.10	73.8 PK	78.2	-4.4	1.89 V	300	66.80	7.00
7	#5860.10	70.1 PK	74.0	-3.9	1.80 V	296	63.10	7.00
8	#5860.10	49.4 AV	54.0	-4.6	1.80 V	296	42.40	7.00
9	11650.00	59.8 PK	74.0	-14.2	1.12 V	46	40.90	18.90
10	11650.00	46.5 AV	54.0	-7.5	1.12 V	46	27.60	18.90

REMARKS:

1. Emission Level(dBuV/m) = Raw Value(dBuV) + Correction Factor(dB/m)
2. Correction Factor(dB/m) = Antenna Factor(dB/m) + Cable Factor(dB)
3. The other emission levels were very low against the limit.
4. Margin value = Emission Level – Limit value
5. " * ": Fundamental frequency.
6. " # ": The radiated frequency is out of the restricted band.

802.11n (HT40)

CHANNEL	TX Channel 38	DETECTOR FUNCTION	Peak (PK)
FREQUENCY RANGE	1GHz ~ 40GHz		Average (AV)

ANTENNA POLARITY & TEST DISTANCE: HORIZONTAL AT 3 M

NO.	FREQ. (MHz)	EMISSION LEVEL (dBuV/m)	LIMIT (dBuV/m)	MARGIN (dB)	ANTENNA HEIGHT (m)	TABLE ANGLE (Degree)	RAW VALUE (dBuV)	CORRECTION FACTOR (dB/m)
1	5150.00	57.6 PK	74.0	-16.4	1.25 H	212	51.60	6.00
2	5150.00	45.9 AV	54.0	-8.1	1.25 H	212	39.90	6.00
3	*5190.00	93.8 PK			1.23 H	177	54.30	39.50
4	*5190.00	84.4 AV			1.23 H	177	44.90	39.50
5	#10380.00	59.8 PK	74.0	-14.2	1.06 H	335	41.30	18.50
6	#10380.00	46.9 AV	54.0	-7.1	1.06 H	335	28.40	18.50

ANTENNA POLARITY & TEST DISTANCE: VERTICAL AT 3 M

NO.	FREQ. (MHz)	EMISSION LEVEL (dBuV/m)	LIMIT (dBuV/m)	MARGIN (dB)	ANTENNA HEIGHT (m)	TABLE ANGLE (Degree)	RAW VALUE (dBuV)	CORRECTION FACTOR (dB/m)
1	5150.00	72.1 PK	74.0	-1.9	1.77 V	174	66.10	6.00
2	5150.00	51.9 AV	54.0	-2.1	1.77 V	174	45.90	6.00
3	*5190.00	106.1 PK			1.76 V	175	66.60	39.50
4	*5190.00	97.3 AV			1.76 V	175	57.80	39.50
5	#10380.00	59.9 PK	74.0	-14.1	1.66 V	154	41.40	18.50
6	#10380.00	47.1 AV	54.0	-6.9	1.66 V	154	28.60	18.50

REMARKS:

1. Emission Level(dBuV/m) = Raw Value(dBuV) + Correction Factor(dB/m)
2. Correction Factor(dB/m) = Antenna Factor(dB/m) + Cable Factor(dB)
3. The other emission levels were very low against the limit.
4. Margin value = Emission Level – Limit value
5. " * ": Fundamental frequency.
6. " # ": The radiated frequency is out of the restricted band.

CHANNEL	TX Channel 46	DETECTOR FUNCTION	Peak (PK)
FREQUENCY RANGE	1GHz ~ 40GHz		Average (AV)

ANTENNA POLARITY & TEST DISTANCE: HORIZONTAL AT 3 M

NO.	FREQ. (MHz)	EMISSION LEVEL (dBuV/m)	LIMIT (dBuV/m)	MARGIN (dB)	ANTENNA HEIGHT (m)	TABLE ANGLE (Degree)	RAW VALUE (dBuV)	CORRECTION FACTOR (dB/m)
1	5150.00	56.7 PK	74.0	-17.3	1.36 H	36	50.70	6.00
2	5150.00	45.7 AV	54.0	-8.3	1.36 H	36	39.70	6.00
3	*5230.00	101.7 PK			1.16 H	70	62.10	39.60
4	*5230.00	91.5 AV			1.16 H	70	51.90	39.60
5	#10460.00	60.3 PK	74.0	-13.7	1.15 H	101	41.40	18.90
6	#10460.00	47.2 AV	54.0	-6.8	1.15 H	101	28.30	18.90

ANTENNA POLARITY & TEST DISTANCE: VERTICAL AT 3 M

NO.	FREQ. (MHz)	EMISSION LEVEL (dBuV/m)	LIMIT (dBuV/m)	MARGIN (dB)	ANTENNA HEIGHT (m)	TABLE ANGLE (Degree)	RAW VALUE (dBuV)	CORRECTION FACTOR (dB/m)
1	5150.00	69.9 PK	74.0	-4.1	1.82 V	106	63.90	6.00
2	5150.00	52.7 AV	54.0	-1.3	1.82 V	106	46.70	6.00
3	*5230.00	113.5 PK			1.63 V	210	73.90	39.60
4	*5230.00	103.1 AV			1.63 V	210	63.50	39.60
5	#10460.00	60.7 PK	74.0	-13.3	1.55 V	301	41.80	18.90
6	#10460.00	47.7 AV	54.0	-6.3	1.55 V	301	28.80	18.90

REMARKS:

1. Emission Level(dBuV/m) = Raw Value(dBuV) + Correction Factor(dB/m)
2. Correction Factor(dB/m) = Antenna Factor(dB/m) + Cable Factor(dB)
3. The other emission levels were very low against the limit.
4. Margin value = Emission Level – Limit value
5. " * ": Fundamental frequency.
6. " # ": The radiated frequency is out of the restricted band.

CHANNEL	TX Channel 151	DETECTOR FUNCTION	Peak (PK)
FREQUENCY RANGE	1GHz ~ 40GHz		Average (AV)

ANTENNA POLARITY & TEST DISTANCE: HORIZONTAL AT 3 M

NO.	FREQ. (MHz)	EMISSION LEVEL (dBuV/m)	LIMIT (dBuV/m)	MARGIN (dB)	ANTENNA HEIGHT (m)	TABLE ANGLE (Degree)	RAW VALUE (dBuV)	CORRECTION FACTOR (dB/m)
1	#5714.90	62.6 PK	74.0	-11.4	1.46 H	115	55.80	6.80
2	#5714.90	47.4 AV	54.0	-6.6	1.46 H	115	40.60	6.80
3	#5722.90	67.9 PK	78.2	-10.3	1.24 H	108	61.10	6.80
4	#5725.00	49.5 PK	78.2	-28.7	1.06 H	106	42.70	6.80
5	*5755.00	100.5 PK			1.00 H	104	60.00	40.50
6	*5755.00	90.8 AV			1.00 H	104	50.30	40.50
7	11510.00	57.3 PK	74.0	-16.7	1.06 H	64	39.00	18.30
8	11510.00	45.9 AV	54.0	-8.1	1.06 H	64	27.60	18.30

ANTENNA POLARITY & TEST DISTANCE: VERTICAL AT 3 M

NO.	FREQ. (MHz)	EMISSION LEVEL (dBuV/m)	LIMIT (dBuV/m)	MARGIN (dB)	ANTENNA HEIGHT (m)	TABLE ANGLE (Degree)	RAW VALUE (dBuV)	CORRECTION FACTOR (dB/m)
1	#5714.90	71.8 PK	74.0	-2.2	1.84 V	299	65.00	6.80
2	#5714.90	52.4 AV	54.0	-1.6	1.84 V	299	45.60	6.80
3	#5722.90	74.6 PK	78.2	-3.6	1.92 V	292	67.80	6.80
4	#5725.00	56.5 PK	78.2	-21.7	1.87 V	293	49.70	6.80
5	*5755.00	107.6 PK			1.58 V	315	67.10	40.50
6	*5755.00	97.8 AV			1.58 V	315	57.30	40.50
7	11510.00	57.5 PK	74.0	-16.5	1.36 V	238	39.20	18.30
8	11510.00	46.2 AV	54.0	-7.8	1.36 V	238	27.90	18.30

REMARKS:

1. Emission Level(dBuV/m) = Raw Value(dBuV) + Correction Factor(dB/m)
2. Correction Factor(dB/m) = Antenna Factor(dB/m) + Cable Factor(dB)
3. The other emission levels were very low against the limit.
4. Margin value = Emission Level – Limit value
5. " * ": Fundamental frequency.
6. " # ": The radiated frequency is out of the restricted band.

CHANNEL	TX Channel 159	DETECTOR FUNCTION	Peak (PK)
FREQUENCY RANGE	1GHz ~ 40GHz		Average (AV)

ANTENNA POLARITY & TEST DISTANCE: HORIZONTAL AT 3 M

NO.	FREQ. (MHz)	EMISSION LEVEL (dBuV/m)	LIMIT (dBuV/m)	MARGIN (dB)	ANTENNA HEIGHT (m)	TABLE ANGLE (Degree)	RAW VALUE (dBuV)	CORRECTION FACTOR (dB/m)
1	5400.00	59.2 PK	74.0	-14.8	1.38 H	127	52.90	6.30
2	5400.00	46.6 AV	54.0	-7.4	1.38 H	127	40.30	6.30
3	*5795.00	104.9 PK			1.11 H	106	64.40	40.50
4	*5795.00	95.8 AV			1.11 H	106	55.30	40.50
5	#5850.00	46.9 PK	78.2	-31.3	1.10 H	107	40.00	6.90
6	#5852.10	60.4 PK	78.2	-17.8	1.01 H	104	53.40	7.00
7	#5860.10	60.0 PK	74.0	-14.0	1.08 H	102	53.00	7.00
8	#5860.10	47.3 AV	54.0	-6.7	1.08 H	102	40.30	7.00
9	11590.00	59.0 PK	74.0	-15.0	1.18 H	65	40.50	18.50
10	11590.00	47.4 AV	54.0	-6.6	1.18 H	65	28.90	18.50

ANTENNA POLARITY & TEST DISTANCE: VERTICAL AT 3 M

NO.	FREQ. (MHz)	EMISSION LEVEL (dBuV/m)	LIMIT (dBuV/m)	MARGIN (dB)	ANTENNA HEIGHT (m)	TABLE ANGLE (Degree)	RAW VALUE (dBuV)	CORRECTION FACTOR (dB/m)
1	5400.00	62.2 PK	74.0	-11.8	1.97 V	123	55.90	6.30
2	5400.00	51.6 AV	54.0	-2.4	1.97 V	123	45.30	6.30
3	*5795.00	111.6 PK			1.74 V	315	71.10	40.50
4	*5795.00	101.8 AV			1.74 V	315	61.30	40.50
5	#5850.00	55.5 PK	78.2	-22.7	1.74 V	294	48.60	6.90
6	#5852.10	69.9 PK	78.2	-8.3	1.73 V	294	62.90	7.00
7	#5860.10	67.5 PK	74.0	-6.5	1.80 V	293	60.50	7.00
8	#5860.10	52.2 AV	54.0	-1.8	1.80 V	293	45.20	7.00
9	11590.00	60.0 PK	74.0	-14.0	1.53 V	218	41.50	18.50
10	11590.00	47.2 AV	54.0	-6.8	1.53 V	218	28.70	18.50

REMARKS:

1. Emission Level(dBuV/m) = Raw Value(dBuV) + Correction Factor(dB/m)
2. Correction Factor(dB/m) = Antenna Factor(dB/m) + Cable Factor(dB)
3. The other emission levels were very low against the limit.
4. Margin value = Emission Level – Limit value
5. " * ": Fundamental frequency.
6. " # ": The radiated frequency is out of the restricted band.

Test Mode B2 – Dipole Antenna: 1TX

802.11a

CHANNEL	TX Channel 36	DETECTOR FUNCTION	Peak (PK)
FREQUENCY RANGE	1GHz ~ 40GHz		Average (AV)

ANTENNA POLARITY & TEST DISTANCE: HORIZONTAL AT 3 M

NO.	FREQ. (MHz)	EMISSION LEVEL (dBuV/m)	LIMIT (dBuV/m)	MARGIN (dB)	ANTENNA HEIGHT (m)	TABLE ANGLE (Degree)	RAW VALUE (dBuV)	CORRECTION FACTOR (dB/m)
1	5150.00	57.0 PK	74.0	-17.0	1.00 H	59	51.00	6.00
2	5150.00	44.8 AV	54.0	-9.2	1.00 H	59	38.80	6.00
3	*5180.00	97.6 PK			1.00 H	63	58.10	39.50
4	*5180.00	87.9 AV			1.00 H	63	48.40	39.50
5	#10360.00	59.1 PK	74.0	-14.9	1.00 H	86	40.70	18.40
6	#10360.00	45.9 AV	54.0	-8.1	1.00 H	86	27.50	18.40

ANTENNA POLARITY & TEST DISTANCE: VERTICAL AT 3 M

NO.	FREQ. (MHz)	EMISSION LEVEL (dBuV/m)	LIMIT (dBuV/m)	MARGIN (dB)	ANTENNA HEIGHT (m)	TABLE ANGLE (Degree)	RAW VALUE (dBuV)	CORRECTION FACTOR (dB/m)
1	5150.00	71.1 PK	74.0	-2.9	1.75 V	280	65.10	6.00
2	5150.00	52.3 AV	54.0	-1.7	1.75 V	280	46.30	6.00
3	*5180.00	106.8 PK			1.07 V	96	67.30	39.50
4	*5180.00	96.0 AV			1.07 V	96	56.50	39.50
5	#10360.00	59.1 PK	74.0	-14.9	1.15 V	38	40.70	18.40
6	#10360.00	46.5 AV	54.0	-7.5	1.15 V	38	28.10	18.40

REMARKS:

1. Emission Level(dBuV/m) = Raw Value(dBuV) + Correction Factor(dB/m)
2. Correction Factor(dB/m) = Antenna Factor(dB/m) + Cable Factor(dB)
3. The other emission levels were very low against the limit.
4. Margin value = Emission Level – Limit value
5. " * ": Fundamental frequency.
6. " # ": The radiated frequency is out of the restricted band.



CHANNEL	TX Channel 40	DETECTOR FUNCTION	Peak (PK)
FREQUENCY RANGE	1GHz ~ 40GHz		Average (AV)

ANTENNA POLARITY & TEST DISTANCE: HORIZONTAL AT 3 M

NO.	FREQ. (MHz)	EMISSION LEVEL (dBuV/m)	LIMIT (dBuV/m)	MARGIN (dB)	ANTENNA HEIGHT (m)	TABLE ANGLE (Degree)	RAW VALUE (dBuV)	CORRECTION FACTOR (dB/m)
1	5150.00	56.6 PK	74.0	-17.4	1.04 H	62	50.60	6.00
2	5150.00	43.9 AV	54.0	-10.1	1.04 H	62	37.90	6.00
3	*5200.00	101.1 PK			1.06 H	63	61.50	39.60
4	*5200.00	90.3 AV			1.06 H	63	50.70	39.60
5	#10400.00	59.3 PK	74.0	-14.7	1.07 H	92	40.80	18.50
6	#10400.00	46.8 AV	54.0	-7.2	1.07 H	92	28.30	18.50

ANTENNA POLARITY & TEST DISTANCE: VERTICAL AT 3 M

NO.	FREQ. (MHz)	EMISSION LEVEL (dBuV/m)	LIMIT (dBuV/m)	MARGIN (dB)	ANTENNA HEIGHT (m)	TABLE ANGLE (Degree)	RAW VALUE (dBuV)	CORRECTION FACTOR (dB/m)
1	5150.00	65.5 PK	74.0	-8.5	1.80 V	280	59.50	6.00
2	5150.00	50.1 AV	54.0	-3.9	1.80 V	280	44.10	6.00
3	*5200.00	112.7 PK			1.72 V	280	73.10	39.60
4	*5200.00	101.8 AV			1.72 V	280	62.20	39.60
5	#10400.00	60.6 PK	74.0	-13.4	1.54 V	327	42.10	18.50
6	#10400.00	47.0 AV	54.0	-7.0	1.54 V	327	28.50	18.50

REMARKS:

1. Emission Level(dBuV/m) = Raw Value(dBuV) + Correction Factor(dB/m)
2. Correction Factor(dB/m) = Antenna Factor(dB/m) + Cable Factor(dB)
3. The other emission levels were very low against the limit.
4. Margin value = Emission Level – Limit value
5. " * ": Fundamental frequency.
6. " # ": The radiated frequency is out of the restricted band.

CHANNEL	TX Channel 48	DETECTOR FUNCTION	Peak (PK)
FREQUENCY RANGE	1GHz ~ 40GHz		Average (AV)

ANTENNA POLARITY & TEST DISTANCE: HORIZONTAL AT 3 M

NO.	FREQ. (MHz)	EMISSION LEVEL (dBuV/m)	LIMIT (dBuV/m)	MARGIN (dB)	ANTENNA HEIGHT (m)	TABLE ANGLE (Degree)	RAW VALUE (dBuV)	CORRECTION FACTOR (dB/m)
1	*5240.00	98.9 PK			1.00 H	63	59.30	39.60
2	*5240.00	89.0 AV			1.00 H	63	49.40	39.60
3	5350.00	57.2 PK	74.0	-16.8	1.12 H	60	51.10	6.10
4	5350.00	44.4 AV	54.0	-9.6	1.12 H	60	38.30	6.10
5	#10480.00	59.9 PK	74.0	-14.1	1.12 H	251	40.90	19.00
6	#10480.00	47.1 AV	54.0	-6.9	1.12 H	251	28.10	19.00

ANTENNA POLARITY & TEST DISTANCE: VERTICAL AT 3 M

NO.	FREQ. (MHz)	EMISSION LEVEL (dBuV/m)	LIMIT (dBuV/m)	MARGIN (dB)	ANTENNA HEIGHT (m)	TABLE ANGLE (Degree)	RAW VALUE (dBuV)	CORRECTION FACTOR (dB/m)
1	*5240.00	112.8 PK			1.61 V	280	73.20	39.60
2	*5240.00	101.6 AV			1.61 V	280	62.00	39.60
3	5350.00	57.7 PK	74.0	-16.3	1.56 V	279	51.60	6.10
4	5350.00	45.3 AV	54.0	-8.7	1.56 V	279	39.20	6.10
5	#10480.00	59.0 PK	74.0	-15.0	1.39 V	332	40.00	19.00
6	#10480.00	47.2 AV	54.0	-6.8	1.39 V	332	28.20	19.00

REMARKS:

1. Emission Level(dBuV/m) = Raw Value(dBuV) + Correction Factor(dB/m)
2. Correction Factor(dB/m) = Antenna Factor(dB/m) + Cable Factor(dB)
3. The other emission levels were very low against the limit.
4. Margin value = Emission Level – Limit value
5. " * ": Fundamental frequency.
6. " # ": The radiated frequency is out of the restricted band.

CHANNEL	TX Channel 149	DETECTOR FUNCTION	Peak (PK)
FREQUENCY RANGE	1GHz ~ 40GHz		Average (AV)

ANTENNA POLARITY & TEST DISTANCE: HORIZONTAL AT 3 M

NO.	FREQ. (MHz)	EMISSION LEVEL (dBuV/m)	LIMIT (dBuV/m)	MARGIN (dB)	ANTENNA HEIGHT (m)	TABLE ANGLE (Degree)	RAW VALUE (dBuV)	CORRECTION FACTOR (dB/m)
1	#5714.90	57.3 PK	74.0	-16.7	1.06 H	114	50.50	6.80
2	#5714.90	44.8 AV	54.0	-9.2	1.06 H	114	38.00	6.80
3	#5722.90	61.6 PK	78.2	-16.6	1.10 H	117	54.80	6.80
4	#5725.00	50.4 PK	78.2	-27.8	1.03 H	116	43.60	6.80
5	*5745.00	98.5 PK			1.00 H	116	58.10	40.40
6	*5745.00	88.3 AV			1.00 H	116	47.90	40.40
7	11490.00	58.1 PK	74.0	-15.9	1.13 H	205	39.70	18.40
8	11490.00	45.9 AV	54.0	-8.1	1.13 H	205	27.50	18.40

ANTENNA POLARITY & TEST DISTANCE: VERTICAL AT 3 M

NO.	FREQ. (MHz)	EMISSION LEVEL (dBuV/m)	LIMIT (dBuV/m)	MARGIN (dB)	ANTENNA HEIGHT (m)	TABLE ANGLE (Degree)	RAW VALUE (dBuV)	CORRECTION FACTOR (dB/m)
1	#5714.90	66.2 PK	74.0	-7.8	1.39 V	279	59.40	6.80
2	#5714.90	49.2 AV	54.0	-4.8	1.39 V	279	42.40	6.80
3	#5722.90	76.4 PK	78.2	-1.8	1.40 V	277	69.60	6.80
4	#5725.00	61.4 PK	78.2	-16.8	1.36 V	279	54.60	6.80
5	*5745.00	109.2 PK			1.60 V	277	68.80	40.40
6	*5745.00	98.7 AV			1.60 V	277	58.30	40.40
7	11490.00	58.0 PK	74.0	-16.0	1.35 V	82	39.60	18.40
8	11490.00	45.6 AV	54.0	-8.4	1.35 V	82	27.20	18.40

REMARKS:

1. Emission Level(dBuV/m) = Raw Value(dBuV) + Correction Factor(dB/m)
2. Correction Factor(dB/m) = Antenna Factor(dB/m) + Cable Factor(dB)
3. The other emission levels were very low against the limit.
4. Margin value = Emission Level – Limit value
5. " * ": Fundamental frequency.
6. " # ": The radiated frequency is out of the restricted band.

CHANNEL	TX Channel 157	DETECTOR FUNCTION	Peak (PK)
FREQUENCY RANGE	1GHz ~ 40GHz		Average (AV)

ANTENNA POLARITY & TEST DISTANCE: HORIZONTAL AT 3 M

NO.	FREQ. (MHz)	EMISSION LEVEL (dBuV/m)	LIMIT (dBuV/m)	MARGIN (dB)	ANTENNA HEIGHT (m)	TABLE ANGLE (Degree)	RAW VALUE (dBuV)	CORRECTION FACTOR (dB/m)
1	*5785.00	103.5 PK			1.08 H	116	63.00	40.50
2	*5785.00	92.1 AV			1.08 H	116	51.60	40.50
3	11570.00	58.7 PK	74.0	-15.3	1.02 H	97	40.30	18.40
4	11570.00	45.4 AV	54.0	-8.6	1.02 H	97	27.00	18.40

ANTENNA POLARITY & TEST DISTANCE: VERTICAL AT 3 M

NO.	FREQ. (MHz)	EMISSION LEVEL (dBuV/m)	LIMIT (dBuV/m)	MARGIN (dB)	ANTENNA HEIGHT (m)	TABLE ANGLE (Degree)	RAW VALUE (dBuV)	CORRECTION FACTOR (dB/m)
1	*5785.00	111.9 PK			1.52 V	279	71.40	40.50
2	*5785.00	101.6 AV			1.52 V	279	61.10	40.50
3	11570.00	58.6 PK	74.0	-15.4	1.22 V	220	40.20	18.40
4	11570.00	45.8 AV	54.0	-8.2	1.22 V	220	27.40	18.40

REMARKS:

1. Emission Level(dBuV/m) = Raw Value(dBuV) + Correction Factor(dB/m)
2. Correction Factor(dB/m) = Antenna Factor(dB/m) + Cable Factor(dB)
3. The other emission levels were very low against the limit.
4. Margin value = Emission Level – Limit value
5. " * ": Fundamental frequency.



CHANNEL	TX Channel 165	DETECTOR FUNCTION	Peak (PK)
FREQUENCY RANGE	1GHz ~ 40GHz		Average (AV)

ANTENNA POLARITY & TEST DISTANCE: HORIZONTAL AT 3 M

NO.	FREQ. (MHz)	EMISSION LEVEL (dBuV/m)	LIMIT (dBuV/m)	MARGIN (dB)	ANTENNA HEIGHT (m)	TABLE ANGLE (Degree)	RAW VALUE (dBuV)	CORRECTION FACTOR (dB/m)
1	*5825.00	101.5 PK			1.04 H	117	61.00	40.50
2	*5825.00	91.1 AV			1.04 H	117	50.60	40.50
3	#5850.00	51.3 PK	78.2	-26.9	1.13 H	117	44.40	6.90
4	#5852.10	67.3 PK	78.2	-10.9	1.13 H	116	60.30	7.00
5	#5860.10	60.6 PK	74.0	-13.4	1.12 H	117	53.60	7.00
6	#5860.10	46.1 AV	54.0	-7.9	1.12 H	117	39.10	7.00
7	11650.00	59.6 PK	74.0	-14.4	1.05 H	94	40.70	18.90
8	11650.00	46.7 AV	54.0	-7.3	1.05 H	94	27.80	18.90

ANTENNA POLARITY & TEST DISTANCE: VERTICAL AT 3 M

NO.	FREQ. (MHz)	EMISSION LEVEL (dBuV/m)	LIMIT (dBuV/m)	MARGIN (dB)	ANTENNA HEIGHT (m)	TABLE ANGLE (Degree)	RAW VALUE (dBuV)	CORRECTION FACTOR (dB/m)
1	*5825.00	111.2 PK			1.01 V	277	70.70	40.50
2	*5825.00	100.7 AV			1.01 V	277	60.20	40.50
3	#5850.00	58.8 PK	78.2	-19.4	1.24 V	290	51.90	6.90
4	#5852.10	76.6 PK	78.2	-1.6	1.32 V	289	69.60	7.00
5	#5860.10	68.3 PK	74.0	-5.7	1.32 V	289	61.30	7.00
6	#5860.10	50.7 AV	54.0	-3.3	1.32 V	289	43.70	7.00
7	11650.00	59.1 PK	74.0	-14.9	1.12 V	224	40.20	18.90
8	11650.00	46.5 AV	54.0	-7.5	1.12 V	224	27.60	18.90

REMARKS:

1. Emission Level(dBuV/m) = Raw Value(dBuV) + Correction Factor(dB/m)
2. Correction Factor(dB/m) = Antenna Factor(dB/m) + Cable Factor(dB)
3. The other emission levels were very low against the limit.
4. Margin value = Emission Level – Limit value
5. " * ": Fundamental frequency.
6. " # ": The radiated frequency is out of the restricted band.

BELOW 1GHz WORST-CASE DATA
Test Mode A1 – PIFA Antenna: 3TX
802.11a

CHANNEL	TX Channel 40	DETECTOR FUNCTION	Quasi-Peak (QP)
FREQUENCY RANGE	30MHz ~ 1GHz		

ANTENNA POLARITY & TEST DISTANCE: HORIZONTAL AT 3 M

NO.	FREQ. (MHz)	EMISSION LEVEL (dBuV/m)	LIMIT (dBuV/m)	MARGIN (dB)	ANTENNA HEIGHT (m)	TABLE ANGLE (Degree)	RAW VALUE (dBuV)	CORRECTION FACTOR (dB/m)
1	99.89	35.5 QP	43.5	-8.0	2.00 H	120	54.40	-18.90
2	166.00	39.0 QP	43.5	-4.5	1.50 H	8	53.20	-14.20
3	239.88	41.5 QP	46.0	-4.5	1.01 H	180	56.50	-15.00
4	298.82	43.0 QP	46.0	-3.0	1.00 H	12	55.50	-12.50
5	499.53	44.9 QP	46.0	-1.1	1.50 H	90	53.20	-8.30
6	696.79	40.9 QP	46.0	-5.1	1.01 H	70	45.20	-4.30

ANTENNA POLARITY & TEST DISTANCE: VERTICAL AT 3 M

NO.	FREQ. (MHz)	EMISSION LEVEL (dBuV/m)	LIMIT (dBuV/m)	MARGIN (dB)	ANTENNA HEIGHT (m)	TABLE ANGLE (Degree)	RAW VALUE (dBuV)	CORRECTION FACTOR (dB/m)
1	99.89	36.0 QP	43.5	-7.5	1.00 V	119	54.90	-18.90
2	166.00	33.6 QP	43.5	-9.9	1.00 V	125	47.80	-14.20
3	239.88	35.7 QP	46.0	-10.3	1.00 V	189	50.70	-15.00
4	300.16	36.5 QP	46.0	-9.5	1.00 V	344	48.90	-12.40
5	499.54	44.1 QP	46.0	-1.9	2.00 V	202	52.40	-8.30
6	696.79	36.2 QP	46.0	-9.8	1.99 V	114	40.50	-4.30

REMARKS:

1. Emission Level(dBuV/m) = Raw Value(dBuV) + Correction Factor(dB/m)
2. Correction Factor(dB/m) = Antenna Factor(dB/m) + Cable Factor(dB)
3. The other emission levels were very low against the limit.
4. Margin value = Emission Level – Limit value

Test Mode B1 – Dipole Antenna: 3TX

802.11a

CHANNEL	TX Channel 40	DETECTOR FUNCTION	Quasi-Peak (QP)
FREQUENCY RANGE	30MHz ~ 1GHz		

ANTENNA POLARITY & TEST DISTANCE: HORIZONTAL AT 3 M								
NO.	FREQ. (MHz)	EMISSION LEVEL (dBuV/m)	LIMIT (dBuV/m)	MARGIN (dB)	ANTENNA HEIGHT (m)	TABLE ANGLE (Degree)	RAW VALUE (dBuV)	CORRECTION FACTOR (dB/m)
1	99.89	36.1 QP	43.5	-7.4	1.99 H	113	55.00	-18.90
2	166.00	37.6 QP	43.5	-5.9	1.99 H	11	51.80	-14.20
3	239.88	42.4 QP	46.0	-3.6	1.00 H	184	57.40	-15.00
4	300.16	45.0 QP	46.0	-1.0	1.00 H	148	57.40	-12.40
5	500.42	44.5 QP	46.0	-1.5	1.49 H	126	52.80	-8.30
6	700.68	39.8 QP	46.0	-6.2	1.00 H	75	44.10	-4.30

ANTENNA POLARITY & TEST DISTANCE: VERTICAL AT 3 M								
NO.	FREQ. (MHz)	EMISSION LEVEL (dBuV/m)	LIMIT (dBuV/m)	MARGIN (dB)	ANTENNA HEIGHT (m)	TABLE ANGLE (Degree)	RAW VALUE (dBuV)	CORRECTION FACTOR (dB/m)
1	99.89	36.0 QP	43.5	-7.5	1.01 V	118	54.90	-18.90
2	166.00	32.8 QP	43.5	-10.7	1.01 V	338	47.00	-14.20
3	239.88	35.8 QP	46.0	-10.2	1.01 V	182	50.80	-15.00
4	300.16	37.9 QP	46.0	-8.1	1.01 V	135	50.30	-12.40
5	500.42	41.5 QP	46.0	-4.5	1.50 V	47	49.80	-8.30
6	696.79	34.3 QP	46.0	-11.7	2.00 V	77	38.60	-4.30

REMARKS:

1. Emission Level(dBuV/m) = Raw Value(dBuV) + Correction Factor(dB/m)
2. Correction Factor(dB/m) = Antenna Factor(dB/m) + Cable Factor(dB)
3. The other emission levels were very low against the limit.
4. Margin value = Emission Level – Limit value

4.2 Conducted Emission Measurement

4.2.1 Limits of Conducted Emission Measurement

Frequency (MHz)	Conducted Limit (dBuV)	
	Quasi-peak	Average
0.15 - 0.5	66 - 56	56 - 46
0.50 - 5.0	56	46
5.0 - 30.0	60	50

Note: 1.

4.2.3 Test Procedures

- a. The EUT was placed 0.4 meters from the conducting wall of the shielded room with EUT being connected to the power mains through a line impedance stabilization network (LISN). Other support units were connected to the power mains through another LISN. The two LISNs provide 50 ohm/ 50uH of coupling impedance for the measuring instrument.
- b. Both lines of the power mains connected to the EUT were checked for maximum conducted interference.
- c. The frequency range from 150kHz to 30MHz was searched. Emission levels under (Limit - 20dB) was not recorded.

NOTE: The resolution bandwidth and video bandwidth of test receiver is 9kHz for quasi-peak detection (QP) and average detection (AV) at frequency 0.15MHz-30MHz.

4.2.4 Deviation from Test Standard

No deviation.

4.2.5 Test Setup

4.2.7 Test Results

Test Mode A1 – PIFA Antenna: 3TX

Phase	Line (L)	Detector Function	Quasi-Peak (QP) / Average (AV)
-------	----------	-------------------	--------------------------------

No	Freq. [MHz]	Corr. Factor (dB)	Reading Value [dB (uV)]		Emission Level [dB (uV)]		Limit [dB (uV)]		Margin (dB)	
			Q.P.	AV.	Q.P.	AV.	Q.P.	AV.	Q.P.	AV.
			1	0.15000	9.82	26.11	26.02	35.93	35.84	66.00
2	0.22820	9.85	20.91	20.89	30.76	30.74	62.51	52.51	-31.76	-21.78
3	0.45498	9.88	16.24	12.80	26.12	22.68	56.78	46.78	-30.66	-24.10
4	2.14801	10.01	23.04	16.46	33.05	26.47	56.00	46.00	-22.95	-19.53
5	18.62475	11.01	15.85	9.92	26.86	20.93	60.00	50.00	-33.14	-29.07
6	21.33829	11.14	15.26	10.14	26.40	21.28	60.00	50.00	-33.60	-28.72

REMARKS:

1. Q.P. and AV. are abbreviations of quasi-peak and average individually.
2. The emission levels of other frequencies were very low against the limit.
3. Margin value = Emission level - Limit value
4. Correction factor = Insertion loss + Cable loss
5. Emission Level = Correction Factor + Reading Value.

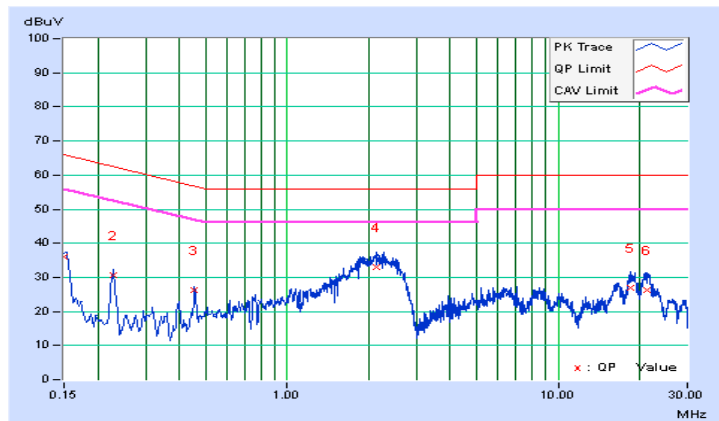

Phase	Neutral (N)	Detector Function	Quasi-Peak (QP) / Average (AV)
-------	-------------	-------------------	--------------------------------

No	Freq. [MHz]	Corr. Factor (dB)	Reading Value [dB (uV)]		Emission Level [dB (uV)]		Limit [dB (uV)]		Margin (dB)	
			Q.P.	AV.	Q.P.	AV.	Q.P.	AV.	Q.P.	AV.
			1	0.15000	9.82	26.12	26.06	35.94	35.88	66.00
2	0.22820	9.84	20.81	20.72	30.65	30.56	62.51	52.51	-31.87	-21.96
3	0.45498	9.88	15.47	12.54	25.35	22.42	56.78	46.78	-31.43	-24.36
4	2.16365	10.00	21.58	15.46	31.58	25.46	56.00	46.00	-24.42	-20.54
5	16.97864	10.79	11.35	5.58	22.14	16.37	60.00	50.00	-37.86	-33.63
6	20.43508	10.93	15.47	10.40	26.40	21.33	60.00	50.00	-33.60	-28.67

REMARKS:

1. Q.P. and AV. are abbreviations of quasi-peak and average individually.
2. The emission levels of other frequencies were very low against the limit.
3. Margin value = Emission level - Limit value
4. Correction factor = Insertion loss + Cable loss
5. Emission Level = Correction Factor + Reading Value.

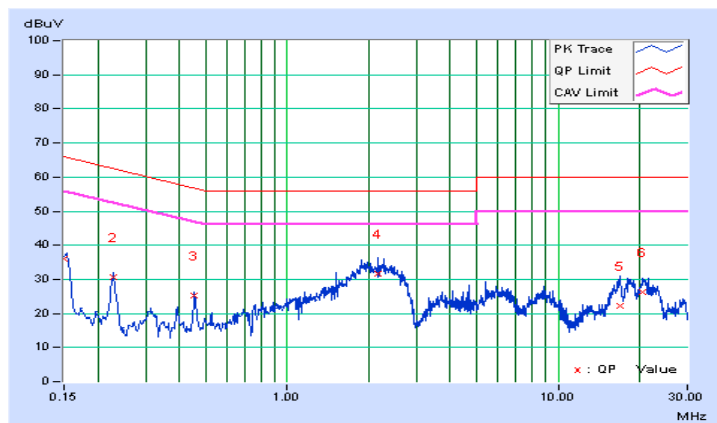

Test Mode B1 – Dipole Antenna: 3TX

Phase	Line (L)	Detector Function	Quasi-Peak (QP) / Average (AV)
-------	----------	-------------------	--------------------------------

No	Freq. [MHz]	Corr. Factor (dB)	Reading Value [dB (uV)]		Emission Level [dB (uV)]		Limit [dB (uV)]		Margin (dB)	
			Q.P.	AV.	Q.P.	AV.	Q.P.	AV.	Q.P.	AV.
			1	0.15391	9.82	26.58	26.50	36.40	36.32	65.79
2	0.22820	9.85	20.22	20.18	30.07	30.03	62.51	52.51	-32.45	-22.49
3	0.45498	9.88	15.56	12.25	25.44	22.13	56.78	46.78	-31.34	-24.65
4	1.85476	9.99	18.44	14.38	28.43	24.37	56.00	46.00	-27.57	-21.63
5	4.22031	10.14	1.15	-3.84	11.29	6.30	56.00	46.00	-44.71	-39.70
6	22.69897	11.19	11.18	6.58	22.37	17.77	60.00	50.00	-37.63	-32.23

REMARKS:

1. Q.P. and AV. are abbreviations of quasi-peak and average individually.
2. The emission levels of other frequencies were very low against the limit.
3. Margin value = Emission level - Limit value
4. Correction factor = Insertion loss + Cable loss
5. Emission Level = Correction Factor + Reading Value.

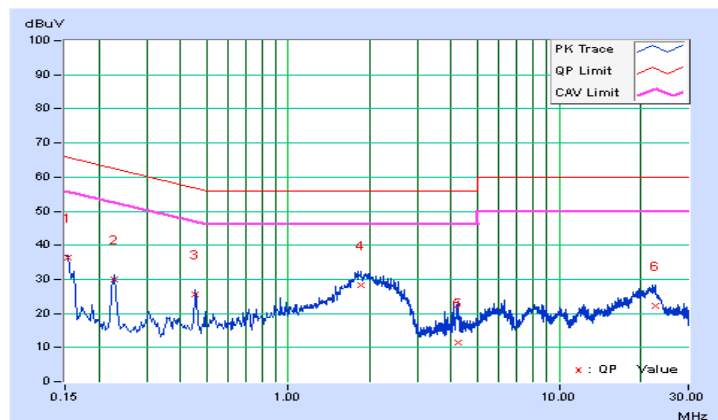

Phase	Neutral (N)	Detector Function	Quasi-Peak (QP) / Average (AV)
-------	-------------	-------------------	--------------------------------

No	Freq. [MHz]	Corr. Factor (dB)	Reading Value [dB (uV)]		Emission Level [dB (uV)]		Limit [dB (uV)]		Margin (dB)	
			Q.P.	AV.	Q.P.	AV.	Q.P.	AV.	Q.P.	AV.
			1	0.15391	9.82	26.57	26.55	36.39	36.37	65.79
2	0.22791	9.84	20.44	20.41	30.28	30.25	62.53	52.53	-32.25	-22.28
3	0.45498	9.88	15.46	12.30	25.34	22.18	56.78	46.78	-31.44	-24.60
4	1.88588	9.98	19.50	14.55	29.48	24.53	56.00	46.00	-26.52	-21.47
5	2.33569	10.01	17.63	13.56	27.64	23.57	56.00	46.00	-28.36	-22.43
6	21.84268	10.96	12.40	7.61	23.36	18.57	60.00	50.00	-36.64	-31.43

REMARKS:

1. Q.P. and AV. are abbreviations of quasi-peak and average individually.
2. The emission levels of other frequencies were very low against the limit.
3. Margin value = Emission level - Limit value
4. Correction factor = Insertion loss + Cable loss
5. Emission Level = Correction Factor + Reading Value.

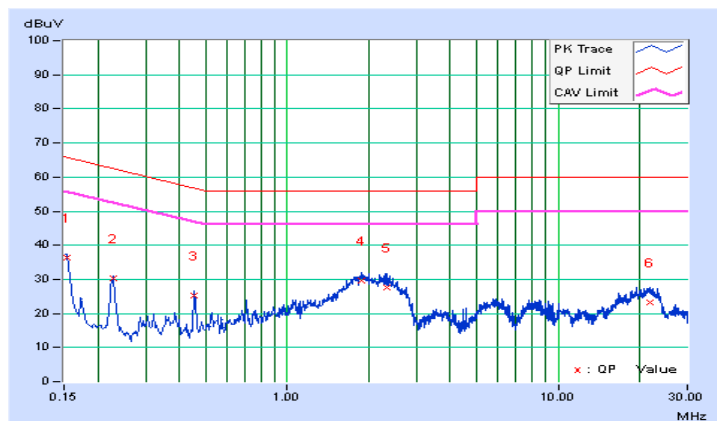

4.3 Transmit Power Measurement

4.3.1 Limits of Transmit Power Measurement

Operation Band	EUT Category	LIMIT
U-NII-1	Outdoor Access Point	1 Watt (30 dBm)

*B is the 26 dB emission bandwidth in megahertz

Per KDB 662911 Method of conducted output power measurement on IEEE 802.11 devices,

- Array Gain = 0 dB (i.e., no array gain) for $N_{ANT} \leq 4$;
- Array Gain = 0 dB (i.e., no array gain) for channel widths ≥ 40 MHz for any N_{ANT} ;
- Array Gain = $5 \log(N_{ANT}/N_{SS})$ dB or 3 dB, whichever is less for 20-MHz channel widths with $N_{ANT} \geq 5$.

For power measurements on all other devices: Array Gain = $10 \log(N_{ANT}/N_{SS})$ dB.

4.3.2 Test Setup

4.3.3 Test Instruments

Refer to section 4.1.2 to get information of above instrument.

4.3.4 Test Procedure

FOR AVERAGE POWER MEASUREMENT

For 802.11a, 802.11n (HT20), 802.11n (HT40)

Method PM is used to perform output power measurement, trigger and gating function of wide band power meter is enabled to measure max output power of TX on burst. Duty factor is not added to measured value.

4.3.5 Deviation from Test Standard

No deviation.

4.3.6 EUT Operating Conditions

The software provided by client to enable the EUT under transmission condition continuously at lowest, middle and highest channel frequencies individually.

4.3.7 Test Result

POWER OUTPUT:

Test Mode A1 – PIFA Antenna: 3TX

802.11a

Channel	Frequency (MHz)	Maximum Conducted Power (dBm)			Maximum Conducted Power (mW)	Maximum Conducted Power (dBm)	Power Limit (dBm)	Pass / Fail
		Chain 0	Chain 1	Chain 2				
36	5180	14.20	13.77	13.54	72.720	18.62	30.00	Pass
40	5200	18.37	18.53	19.19	222.977	23.48	30.00	Pass
48	5240	16.38	15.13	15.63	112.594	20.52	30.00	Pass
149	5745	13.21	12.07	14.32	64.087	18.07	30.00	Pass
157	5785	16.80	15.71	17.09	136.270	21.34	30.00	Pass
165	5825	16.58	15.62	16.44	126.029	21.00	30.00	Pass

802.11n (HT20)

Channel	Frequency (MHz)	Maximum Conducted Power (dBm)			Maximum Conducted Power (mW)	Maximum Conducted Power (dBm)	Power Limit (dBm)	Pass / Fail
		Chain 0	Chain 1	Chain 2				
36	5180	14.15	13.16	13.62	69.717	18.43	30.00	Pass
40	5200	18.01	18.22	18.86	206.528	23.15	30.00	Pass
48	5240	16.18	15.17	15.95	113.735	20.56	30.00	Pass
149	5745	12.09	10.16	12.23	43.267	16.36	30.00	Pass
157	5785	15.81	14.29	15.89	103.775	20.16	30.00	Pass
165	5825	16.34	15.06	15.94	114.380	20.58	30.00	Pass

802.11n (HT40)

Channel	Frequency (MHz)	Maximum Conducted Power (dBm)			Maximum Conducted Power (mW)	Maximum Conducted Power (dBm)	Power Limit (dBm)	Pass / Fail
		Chain 0	Chain 1	Chain 2				
38	5190	11.44	10.48	10.36	35.965	15.56	30.00	Pass
46	5230	16.11	15.03	15.83	110.956	20.45	30.00	Pass
151	5755	11.14	9.55	11.40	35.822	15.54	30.00	Pass
159	5795	15.77	14.21	15.90	103.025	20.13	30.00	Pass

Test Mode A2 – PIFA Antenna: 1TX

Channel	Frequency (MHz)	Maximum Conducted Power (mW)	Maximum Conducted Power (dBm)	Power Limit (dBm)	Pass / Fail
36	5180	34.435	15.37	30.00	Pass
40	5200	51.523	17.12	30.00	Pass
48	5240	53.951	17.32	30.00	Pass
149	5745	31.477	14.98	30.00	Pass
157	5785	73.114	18.64	30.00	Pass
165	5825	62.806	17.98	30.00	Pass

26dB BANDWIDTH:
Test Mode A1 – PIFA Antenna: 3TX
802.11a

Channel	Frequency (MHz)	26dBc Bandwidth (MHz)			Pass / Fail
		Chain 0	Chain 1	Chain 2	
36	5180	36.62	24.15	22.86	Pass
40	5200	44.99	42.26	40.93	Pass
48	5240	38.66	27.89	26.57	Pass

802.11n (HT20)

Channel	Frequency (MHz)	26dBc Bandwidth (MHz)			Pass / Fail
		Chain 0	Chain 1	Chain 2	
36	5180	31.96	24.43	24.53	Pass
40	5200	47.11	43.49	42.77	Pass
48	5240	40.54	27.18	28.37	Pass

802.11n (HT40)

Channel	Frequency (MHz)	26dBc Bandwidth (MHz)			Pass / Fail
		Chain 0	Chain 1	Chain 2	
38	5190	50.95	47.72	47.91	Pass
46	5230	88.07	74.25	70.25	Pass

Spectrum Plot of Worst Value

802.11a

802.11n (HT20)

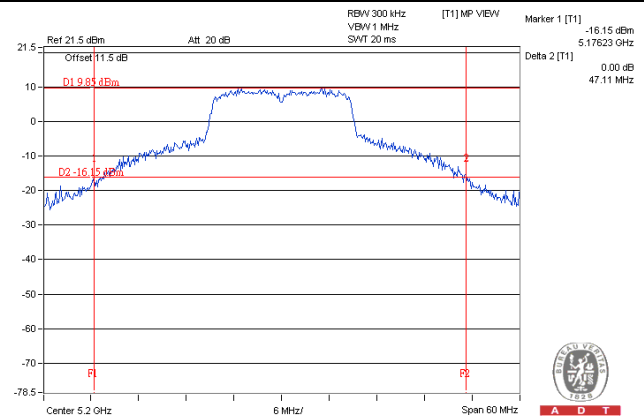
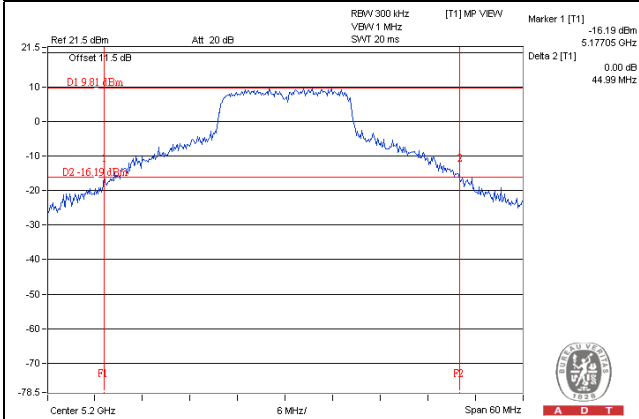

802.11n (HT40)

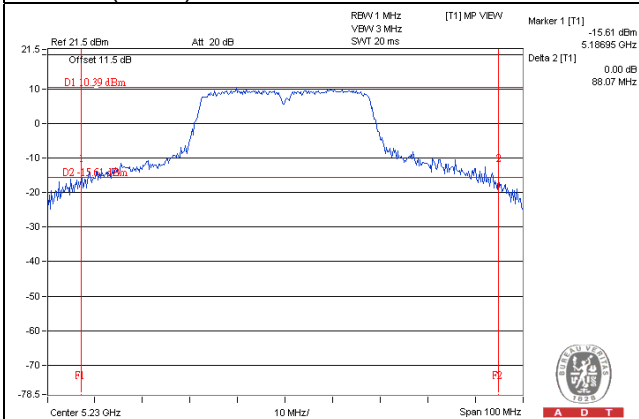

Test Mode A2 – PIFA Antenna: 1TX

Channel	Frequency (MHz)	26dBc Bandwidth (MHz)	Pass / Fail
36	5180	31.79	Pass
40	5200	38.02	Pass
48	5240	39.78	Pass

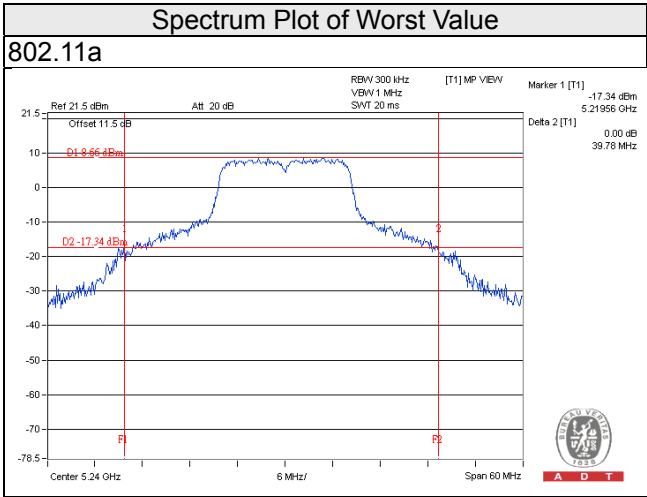

OCCUPIED BANDWIDTH:
Test Mode A1 – PIFA Antenna: 3TX
802.11a

Channel	Frequency (MHz)	Occupied Bandwidth (MHz)		
		Chain 0	Chain 1	Chain 2
36	5180	17.04	16.80	16.80
40	5200	28.68	25.56	24.84
48	5240	18.24	16.92	16.80
149	5745	16.80	16.68	16.80
157	5785	21.12	16.92	18.00
165	5825	18.24	17.04	17.28

802.11n (HT20)

Channel	Frequency (MHz)	Occupied Bandwidth (MHz)		
		Chain 0	Chain 1	Chain 2
36	5180	18.12	17.88	17.88
40	5200	29.40	24.60	24.60
48	5240	19.32	18.12	18.12
149	5745	17.64	17.88	17.88
157	5785	18.48	18.00	18.24
165	5825	19.56	17.88	18.24

802.11n (HT40)

Channel	Frequency (MHz)	Occupied Bandwidth (MHz)		
		Chain 0	Chain 1	Chain 2
38	5190	36.96	36.84	36.72
46	5230	37.56	36.84	36.84
151	5755	36.84	36.84	36.84
159	5795	37.32	36.72	37.20

Spectrum Plot of Worst Value

802.11a

802.11n (HT20)

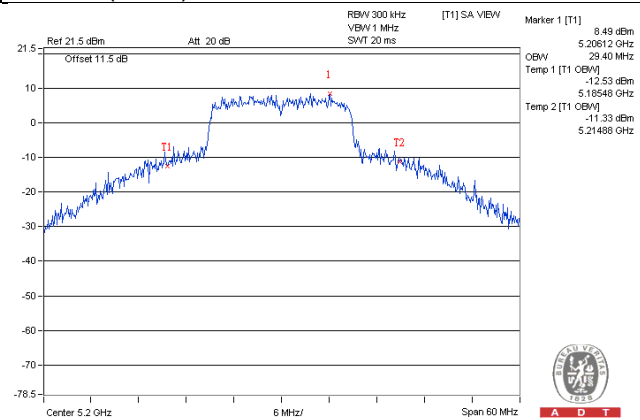
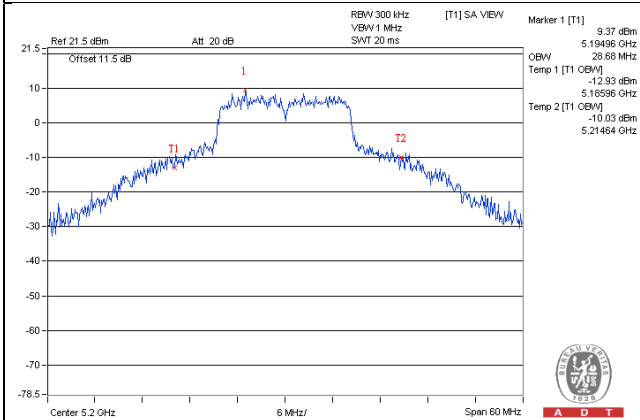

802.11n (HT40)

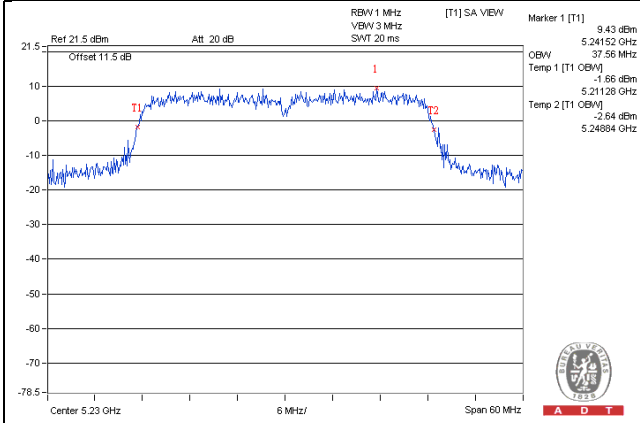

Test Mode A2 – PIFA Antenna: 1TX

802.11a

Channel	Frequency (MHz)	Occupied Bandwidth (MHz)
36	5180	17.16
40	5200	18.60
48	5240	19.08
149	5745	16.92
157	5785	26.76
165	5825	22.56

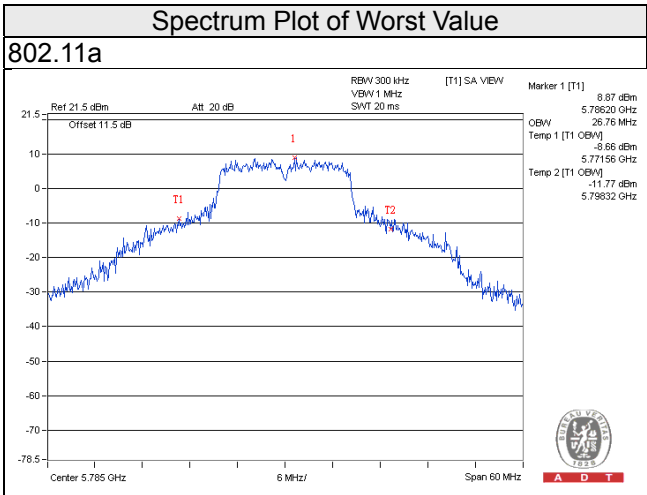

4.4 Peak Power Spectral Density Measurement

4.4.1 Limits of Peak Power Spectral Density Measurement

Operation Band	EUT Category		LIMIT
U-NII-1		Outdoor Access Point	17dBm/ MHz
		Fixed point-to-point Access Point	
	√	Indoor Access Point	
		Mobile and Portable client device	11dBm/ MHz
U-NII-2A	-		11dBm/ MHz
U-NII-2C	-		11dBm/ MHz
U-NII-3	√		30dBm/ 500kHz

4.4.2 Test Setup

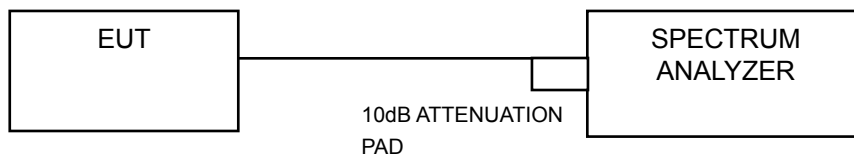

4.4.3 Test Instruments

Refer to section 4.1.2 to get information of above instrument.

4.4.4 Test Procedures

For U-NII-1 band:

Using method SA-2

- a. Set span to encompass the entire emission bandwidth (EBW) of the signal.
- b. Set RBW = 1 MHz, Set VBW \geq 3 MHz, Detector = RMS
- c. Sweep time = auto, trigger set to "free run".
- d. Trace average at least 100 traces in power averaging mode.
- e. Record the max value and add 10 log (1/duty cycle)

For U-NII-3 band:

- a. Set span to encompass the entire emission bandwidth (EBW) of the signal.
- b. Set RBW = 300 kHz, Set VBW \geq 1 MHz, Detector = RMS
- c. Use the peak marker function to determine the maximum power level in any 300 kHz band segment within the fundamental EBW.
- d. Scale the observed power level to an equivalent value in 500 kHz by adjusting (reducing) the measured power by a bandwidth correction factor (BWCF) where $BWCF = 10\log(500 \text{ kHz}/300\text{kHz})$
- e. Sweep time = auto, trigger set to "free run".
- f. Trace average at least 100 traces in power averaging mode.
- g. Record the max value and add 10 log (1/duty cycle)

4.4.5 Deviation from Test Standard

No deviation.

4.4.6 EUT Operating Conditions

Same as Item 4.3.6.

4.4.7 Test Results

For U-NII-1 Band

Test Mode A1 – PIFA Antenna: 3TX

802.11a

Chan.	Frequency (MHz)	PSD (dBm/MHz)			Total PSD W/O Duty Factor (dBm/MHz)	Duty Factor	Total PSD With Duty Factor (dBm/MHz)	Maximum Limit (dBm/MHz)	Pass / Fail
		Chain 0	Chain 1	Chain 2					
36	5180	0.55	-0.07	-0.01	4.94	0.16	5.10	12.23	Pass
40	5200	3.97	5.08	5.46	9.65	0.16	9.81	12.23	Pass
48	5240	2.02	0.60	2.07	6.39	0.16	6.55	12.23	Pass

Note:

- Method 1 of power density measurement of KDB 662911 is using for calculating total power density. Total power density is summing entire spectra across corresponding frequency bins on the various outputs by computer.
- For U-NII-1:** Directional gain = 6dBi + 10log(3) = 10.77dBi > 6dBi, so the power density limit shall be reduced to 17-(10.77-6) = 12.23dBm.
- Refer to section 3.3 for duty cycle spectrum plot.

802.11n (HT20)

Chan.	Frequency (MHz)	PSD (dBm/MHz)			Total PSD W/O Duty Factor (dBm/MHz)	Duty Factor	Total PSD With Duty Factor (dBm/MHz)	Maximum Limit (dBm/MHz)	Pass / Fail
		Chain 0	Chain 1	Chain 2					
36	5180	0.26	-0.13	0.21	4.89	0.17	5.06	12.23	Pass
40	5200	4.05	4.78	5.00	9.40	0.17	9.57	12.23	Pass
48	5240	1.84	0.78	1.54	6.18	0.17	6.35	12.23	Pass

Note:

- Method 1 of power density measurement of KDB 662911 is using for calculating total power density. Total power density is summing entire spectra across corresponding frequency bins on the various outputs by computer.
- For U-NII-1:** Directional gain = 6dBi + 10log(3) = 10.77dBi > 6dBi, so the power density limit shall be reduced to 17-(10.77-6) = 12.23dBm.
- Refer to section 3.3 for duty cycle spectrum plot.

802.11n (HT40)

Chan.	Frequency (MHz)	PSD (dBm/MHz)			Total PSD W/O Duty Factor (dBm/MHz)	Duty Factor	Total PSD With Duty Factor (dBm/MHz)	Maximum Limit (dBm/MHz)	Pass / Fail
		Chain 0	Chain 1	Chain 2					
38	5190	-5.48	-6.34	-5.99	-1.16	0.26	-0.90	12.23	Pass
46	5230	-1.11	-2.41	-1.15	3.25	0.26	3.51	12.23	Pass

Note:

- Method 1 of power density measurement of KDB 662911 is using for calculating total power density. Total power density is summing entire spectra across corresponding frequency bins on the various outputs by computer.
- For U-NII-1:** Directional gain = $6\text{dBi} + 10\log(3) = 10.77\text{dBi} > 6\text{dBi}$, so the power density limit shall be reduced to $17 - (10.77 - 6) = 12.23\text{dBm}$.
- Refer to section 3.3 for duty cycle spectrum plot.

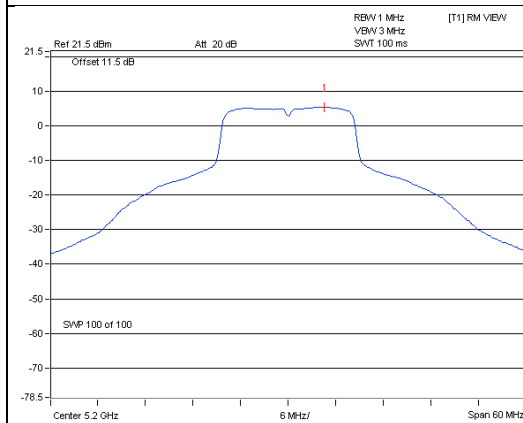
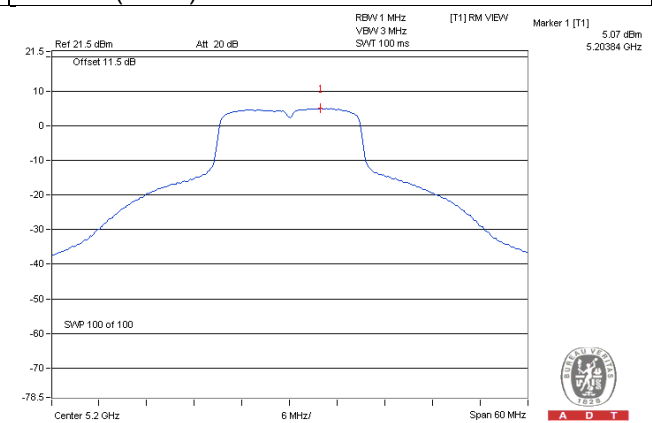
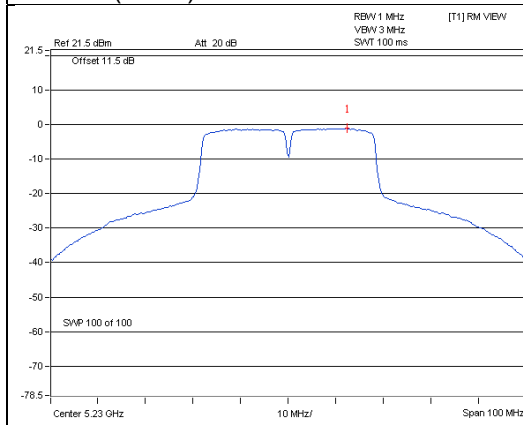
Spectrum Plot of Worst Value
802.11a / CH 40 / Chain 2

802.11n (HT20) / CH 40 / Chain 2

802.11n (HT40) / CH 46 / Chain 0

Test Mode A2 – PIFA Antenna: 1TX

802.11a

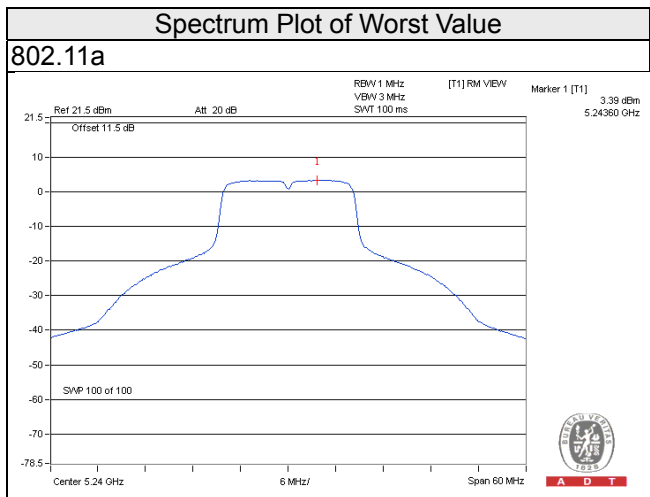
Chan.	Frequency (MHz)	PSD W/O Duty Factor (dBm/MHz)	Duty Factor	PSD With Duty Factor (dBm/MHz)	Maximum Limit (dBm/MHz)	Pass / Fail
36	5180	2.05	0.16	2.21	17.00	Pass
40	5200	3.30	0.16	3.46	17.00	Pass
48	5240	3.39	0.16	3.55	17.00	Pass

NOTE: Refer to section 3.3 for duty cycle spectrum plot.



For U-NII-3 Band

Test Mode A1 – PIFA Antenna: 3TX

802.11a

TX chain	Channel	Freq. (MHz)	PSD (dBm/300kHz)	PSD (dBm/500kHz)	10 log (N=3) dB	Duty Factor	Total PSD (dBm/500kHz)	Limit (dBm/500kHz)	Pass /Fail
0	149	5745	-7.82	-5.60	4.77	0.16	-0.67	25.23	Pass
	157	5785	-5.23	-3.01	4.77	0.16	1.92	25.23	Pass
	165	5825	-5.78	-3.56	4.77	0.16	1.37	25.23	Pass
1	149	5745	-9.85	-7.63	4.77	0.16	-2.70	25.23	Pass
	157	5785	-6.31	-4.09	4.77	0.16	0.84	25.23	Pass
	165	5825	-6.36	-4.14	4.77	0.16	0.79	25.23	Pass
2	149	5745	-7.38	-5.16	4.77	0.16	-0.23	25.23	Pass
	157	5785	-5.17	-2.95	4.77	0.16	1.98	25.23	Pass
	165	5825	-6.00	-3.78	4.77	0.16	1.15	25.23	Pass

Note:

1. Directional gain = $6\text{dBi} + 10\log(3) = 10.77\text{dBi} > 6\text{dBi}$, so the power density limit shall be reduced to $30 - (10.77 - 6) = 25.23\text{dBm}$.
2. Refer to section 3.3 for duty cycle spectrum plot.

802.11n (HT20)

TX chain	Channel	Freq. (MHz)	PSD (dBm/300kHz)	PSD (dBm/500kHz)	10 log (N=3) dB	Duty Factor	Total PSD (dBm/500kHz)	Limit (dBm/500kHz)	Pass /Fail
0	149	5745	-10.12	-7.90	4.77	0.17	-2.96	25.23	Pass
	157	5785	-6.39	-4.17	4.77	0.17	0.77	25.23	Pass
	165	5825	-6.01	-3.79	4.77	0.17	1.15	25.23	Pass
1	149	5745	-11.80	-9.58	4.77	0.17	-4.64	25.23	Pass
	157	5785	-8.05	-5.83	4.77	0.17	-0.89	25.23	Pass
	165	5825	-6.92	-4.70	4.77	0.17	0.24	25.23	Pass
2	149	5745	-9.81	-7.59	4.77	0.17	-2.65	25.23	Pass
	157	5785	-6.13	-3.91	4.77	0.17	1.03	25.23	Pass
	165	5825	-6.61	-4.39	4.77	0.17	0.55	25.23	Pass

Note:

1. Directional gain = $6\text{dBi} + 10\log(3) = 10.77\text{dBi} > 6\text{dBi}$, so the power density limit shall be reduced to $30 - (10.77 - 6) = 25.23\text{dBm}$.
2. Refer to section 3.3 for duty cycle spectrum plot.

802.11n (HT40)

TX chain	Channel	Freq. (MHz)	PSD (dBm/300kHz)	PSD (dBm/500kHz)	10 log (N=3) dB	Duty Factor	Total PSD (dBm/500kHz)	Limit (dBm/500kHz)	Pass /Fail
0	151	5755	-13.84	-11.62	4.77	0.26	-6.59	25.23	Pass
	159	5795	-9.71	-7.49	4.77	0.26	-2.46	25.23	Pass
1	151	5755	-15.94	-13.72	4.77	0.26	-8.69	25.23	Pass
	159	5795	-11.21	-8.99	4.77	0.26	-3.96	25.23	Pass
2	151	5755	-13.67	-11.45	4.77	0.26	-6.42	25.23	Pass
	159	5795	-10.12	-7.90	4.77	0.26	-2.87	25.23	Pass

Note:

- Directional gain = $6\text{dBi} + 10\log(3) = 10.77\text{dBi} > 6\text{dBi}$, so the power density limit shall be reduced to $30 - (10.77 - 6) = 25.23\text{dBm}$.
- Refer to section 3.3 for duty cycle spectrum plot.

Spectrum Plot of Worst Value

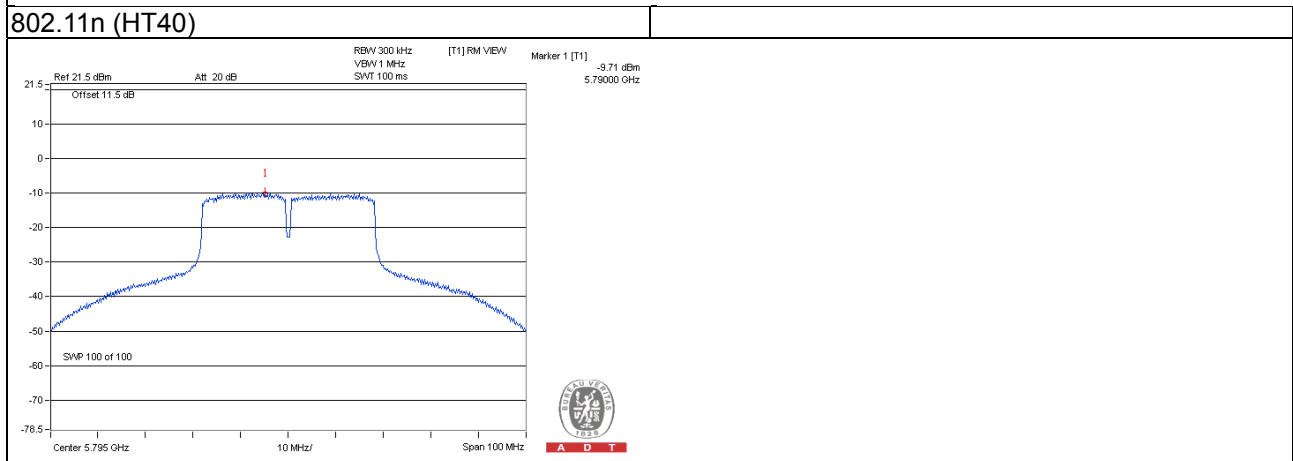
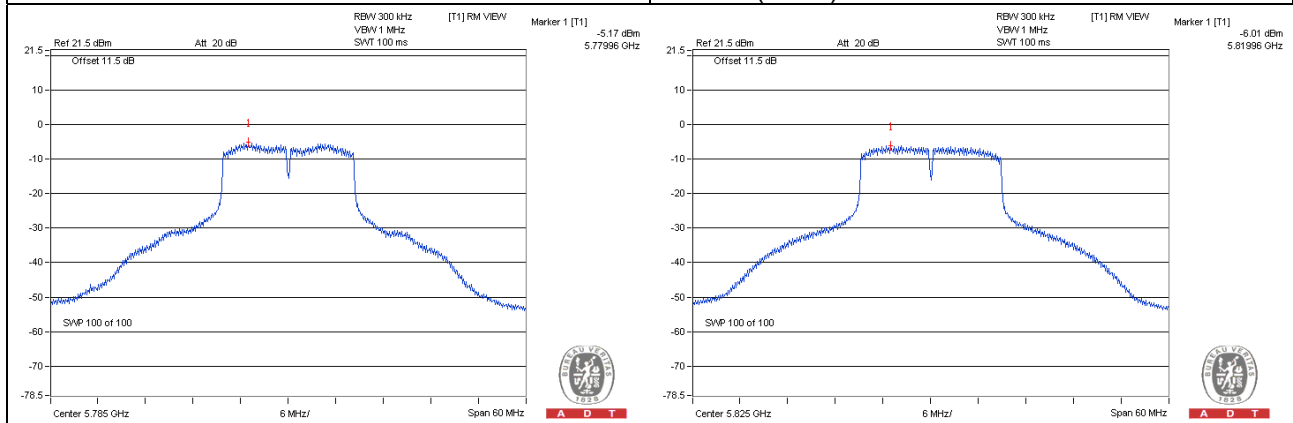

Test Mode A2 – PIFA Antenna: 1TX

Channel	Freq. (MHz)	PSD (dBm/300kHz)	PSD (dBm/500kHz)	Duty Factor	Total PSD (dBm/500kHz)	Limit (dBm/500kHz)	Pass /Fail
149	5745	-6.58	-4.36	0.16	-4.20	30.00	Pass
157	5785	-3.43	-1.21	0.16	-1.05	30.00	Pass
165	5825	-3.88	-1.66	0.16	-1.50	30.00	Pass

NOTE: Refer to section 3.3 for duty cycle spectrum plot.

Spectrum Plot of Worst Value

802.11a

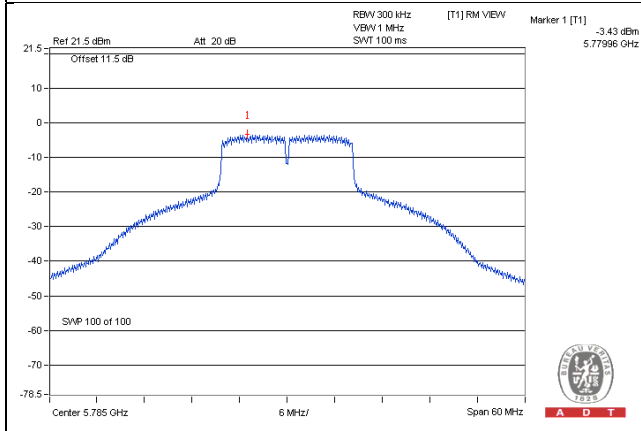

4.5 Frequency Stability

4.5.1 Limits of Frequency Stability Measurement

The frequency of the carrier signal shall be maintained within band of operation

4.5.2 Test Setup

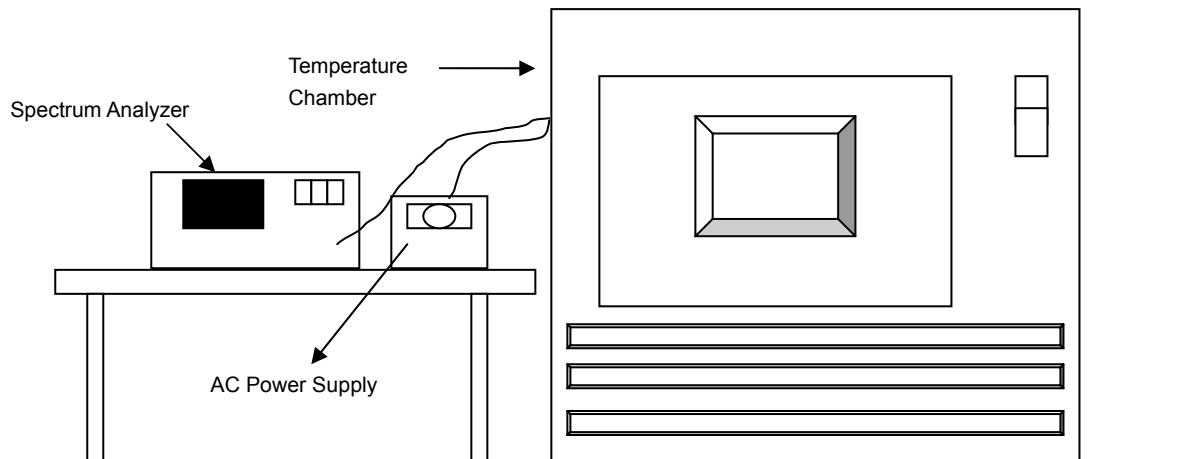

4.5.3 Test Instruments

Refer to section 4.1.2 to get information of above instrument.

4.5.4 Test Procedure

- a. The EUT was placed inside the environmental test chamber and powered by nominal AC voltage.
- b. Turn the EUT on and couple its output to a spectrum analyzer.
- c. Turn the EUT off and set the chamber to the highest temperature specified.
- d. Allow sufficient time (approximately 30 min) for the temperature of the chamber to stabilize, turn the EUT on and measure the operating frequency after 2, 5, and 10 minutes.
- e. Repeat step 2 and 3 with the temperature chamber set to the lowest temperature.
- f. The test chamber was allowed to stabilize at +20 degree C for a minimum of 30 minutes. The supply voltage was then adjusted on the EUT from 85% to 115% and the frequency record.

4.5.5 Deviation from Test Standard

No deviation.

4.5.6 EUT Operating Condition

Set the EUT transmit at un-modulation mode to test frequency stability.

4.5.7 Test Results

Test Mode A1 – PIFA Antenna: 3TX

Frequency Stability Versus Temp.
Operating Frequency: 5180MHz

Temp.
(



Test Mode A2 – PIFA Antenna: 1TX

Frequency Stability Versus Temp.

Operating Frequency: 5180MHz

Temp.
(

4.6 6dB Bandwidth Measurement

4.6.1 Limits of 6dB Bandwidth Measurement

The minimum of 6dB Bandwidth Measurement is 0.5MHz.

4.6.2 Test Setup

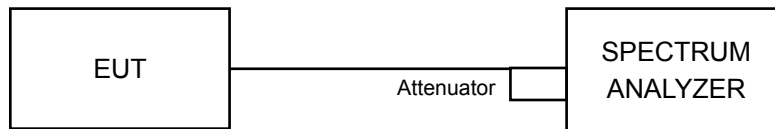

4.6.3 Test Instruments

Refer to section 4.1.2 to get information of above instrument.

4.6.4 Test Procedure

MEASUREMENT PROCEDURE REF

- Set resolution bandwidth (RBW) = 100kHz
- Set the video bandwidth (VBW) $\geq 3 \times$ RBW, Detector = Peak.
- Trace mode = max hold.
- Sweep = auto couple.
- Measure the maximum width of the emission that is constrained by the frequencies associated with the two amplitude points (upper and lower) that are attenuated by 6 dB relative to the maximum level measured in the fundamental emission

4.6.5 Deviation from Test Standard

No deviation.

4.6.6 EUT Operating Condition

The software provided by client to enable the EUT under transmission condition continuously at lowest, middle and highest channel frequencies individually.

4.6.7 Test Results

Test Mode A1 – PIFA Antenna: 3TX

802.11a

Channel	Frequency (MHz)	6dB Bandwidth (MHz)			Minimum Limit (MHz)	Pass / Fail
		Chain 0	Chain 1	Chain 2		
149	5745	16.09	16.38	16.37	0.5	Pass
157	5785	15.41	15.40	15.15	0.5	Pass
165	5825	15.70	15.90	15.39	0.5	Pass

802.11n (HT20)

Channel	Frequency (MHz)	6dB Bandwidth (MHz)			Minimum Limit (MHz)	Pass / Fail
		Chain 0	Chain 1	Chain 2		
149	5745	16.55	16.91	16.67	0.5	Pass
157	5785	16.20	15.43	15.74	0.5	Pass
165	5825	15.76	15.50	15.18	0.5	Pass

802.11n (HT40)

Channel	Frequency (MHz)	6dB Bandwidth (MHz)			Minimum Limit (MHz)	Pass / Fail
		Chain 0	Chain 1	Chain 2		
151	5755	35.56	35.87	35.54	0.5	Pass
159	5795	35.26	35.30	35.24	0.5	Pass

Spectrum Plot of Worst Value

802.11a

802.11n (HT20)

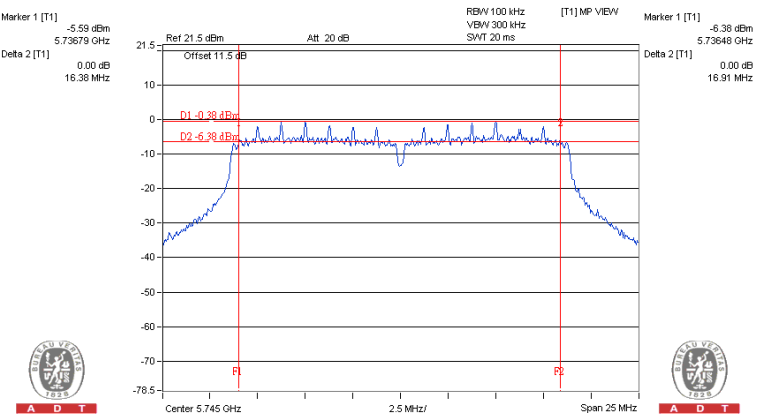
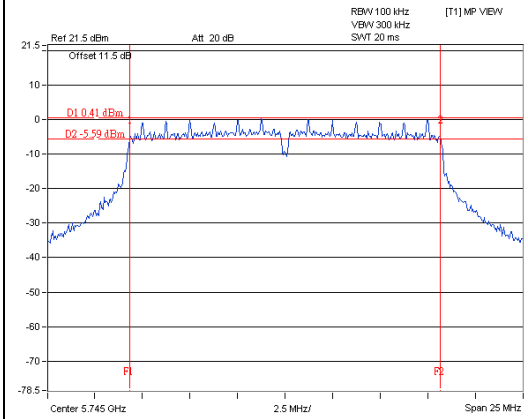

802.11n (HT40)

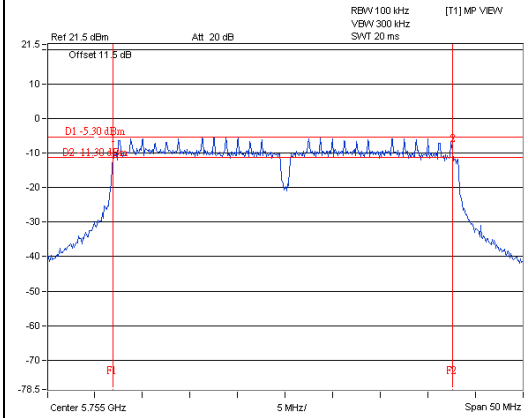

Test Mode A2 – PIFA Antenna: 1TX

802.11a

Channel	Frequency (MHz)	6dB Bandwidth (MHz)	Minimum Limit (MHz)	Pass / Fail
149	5745	16.35	0.5	Pass
157	5785	16.32	0.5	Pass
165	5825	15.96	0.5	Pass

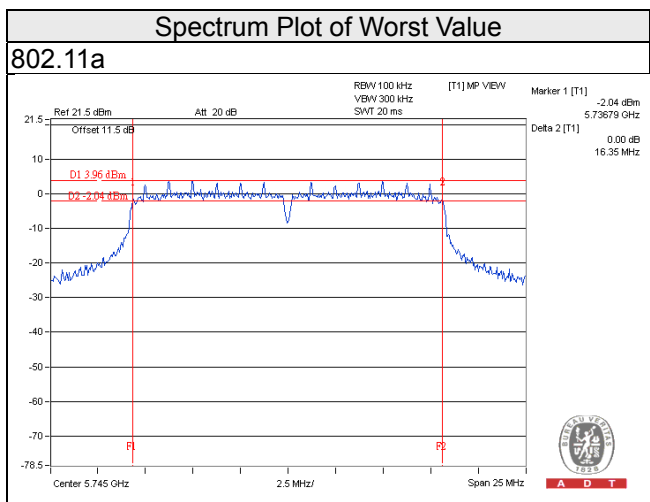

5 Pictures of Test Arrangements

Please refer to the attached file (Test Setup Photo).

Appendix – Information on the Testing Laboratories

We, Bureau Veritas Consumer Products Services (H.K.) Ltd., Taoyuan Branch, were founded in 1988 to provide our best service in EMC, Radio, Telecom and Safety consultation. Our laboratories are accredited and approved according to ISO/IEC 17025.

If you have any comments, please feel free to contact us at the following:

Linko EMC/RF Lab

Tel: 886-2-26052180

Fax: 886-2-26051924

Hsin Chu EMC/RF/Telecom Lab

Tel: 886-3-5935343

Fax: 886-3-5935342

Hwa Ya EMC/RF/Safety Lab

Tel: 886-3-3183232

Fax: 886-3-3270892

Email: service.adt@tw.bureauveritas.com

Web Site: www.bureauveritas-adt.com

The address and road map of all our labs can be found in our web site also.

--- END ---