



FCC & Industry Canada Certification Test Report

**For the
Adtran, Inc.
Tracer 6410**

**HDCTRC6410
2250A-TRC6410**

**WLL JOB# 8957
November 2005**

Prepared for:

**Adtran, Inc.
901 Explorer Boulevard
Huntsville, AL 35806**

Prepared By:

**Washington Laboratories, Ltd.
7560 Lindbergh Drive
Gaithersburg, Maryland 20879**

FCC & Industry Canada Certification Test Report
for the
Adtran, Inc.
Tracer 6410
FCC ID: HDCTRC6410
IC ID: 2250A-TRC6410

November 2005

WLL JOB# 8957

Prepared by: Brian J. Dettling
Documentation Specialist

Reviewed by: Gregory M. Snyder
Chief EMC Engineer

Abstract

This report has been prepared on behalf of Adtran, Inc. to support the attached Application for Equipment Authorization. The test report and application are submitted for a digitally modulated transmitter under Part 15.247 of the FCC Rules and Regulations and Spectrum Management and Telecommunications Policy RSS-210 of Industry Canada. This Certification Test Report documents the test configuration and test results for an Adtran, Inc. Tracer 6410.

Testing was performed on an Open Area Test Site (OATS) of Washington Laboratories, Ltd, 7560 Lindbergh Drive, Gaithersburg, MD 20879. Site description and site attenuation data have been placed on file with the FCC's Sampling and Measurements Branch at the FCC laboratory in Columbia, MD. The Industry Canada OATS numbers are 3035A-1 and 3035A-2 for Washington Laboratories, Ltd. Site 1 and Site 2, respectively. Washington Laboratories, Ltd. has been accepted by the FCC and approved by NIST NVLAP (NVLAP Lab Code: 200066-0) as an independent FCC test laboratory.

The Adtran, Inc. Tracer 6410 complies with the limits for a Digitally Modulated Transceiver device under FCC Part 15.247 and Industry Canada RSS-210.

Table of Contents

Abstract..... ii

1 Introduction..... 1

 1.1 Compliance Statement 1

 1.2 Test Scope..... 1

 1.3 Contract Information..... 1

 1.4 Test Dates 1

 1.5 Test and Support Personnel 1

 1.6 Abbreviations..... **Error! Bookmark not defined.**

2 Equipment Under Test 2

 2.1 EUT Identification & Description 2

 2.2 Test Configuration 3

 2.3 Testing Algorithm..... 3

 2.4 Test Location 3

 2.5 Measurements 4

 2.5.1 References..... 4

 2.6 Measurement Uncertainty 4

3 Test Equipment 5

4 Test Results..... 6

 4.1 RF Power Output: (§15.247(b))..... 6

 4.2 Occupied Bandwidth: (§15.247(a)(2))..... 7

 4.3 RF Peak Power Spectral Density (§15.247(e))..... 14

 4.4 Conducted Spurious Emissions at Antenna Terminals (FCC Part §15.247(d)) 21

 4.5 Radiated Spurious Emissions: (FCC Part §15.247(c)) 46

 4.5.1 Test Procedure 46

 4.6 AC Powerline Conducted Emissions: (FCC Part §15.207) 52

List of Tables

Table 1. Device Summary..... 2

Table 2: Test Equipment List..... 5

Table 3. RF Power Output 6

Table 4. Occupied Bandwidth Results..... 14

Table 5. RF Power Spectral Density..... 21

Table 6: Radiated Emission Test Data, Low Frequency Data (<1GHz) 47

Table 7: Radiated Emission Test Data, High Frequency Data: Plan A, Band 1 (2419MHz)..... 47

Table 8: Radiated Emission Test Data, High Frequency Data: Plan A, Band 3 (2425MHz)..... 49

Table 9: Radiated Emission Test Data, High Frequency Data: Plan B, Band 3 (2465MHz)..... 50

Table 10: Conducted Emissions Test Data; §15.207 52

List of Figures

Figure 1. Power Measurement Setup.....	7
Figure 2. Occupied Bandwidth - Plan A, Band 1	8
Figure 3. Occupied Bandwidth - Plan A, Band 2	9
Figure 4. Occupied Bandwidth - Plan A, Band 3	10
Figure 5. Occupied Bandwidth - Plan B, Band 1.....	11
Figure 6. Occupied Bandwidth - Plan B, Band 2.....	12
Figure 7. Occupied Bandwidth - Plan B, Band 3.....	13
Figure 8. Power Spectral Density Plan A, Band 1	15
Figure 9. Power Spectral Density Plan A, Band 2.....	16
Figure 10. Power Spectral Density Plan A, Band 3.....	17
Figure 11. Power Spectral Density Plan B, Band 1	18
Figure 12. Power Spectral Density Plan B, Band 2.....	19
Figure 13. Power Spectral Density Plan B, Band 3	20
Figure 14. Conducted Spurious Emissions, Plan A Band 1, 30MHz - 1GHz	22
Figure 15. Conducted Spurious Emissions, Plan A Band 1, 1GHz – 2.4GHz.....	23
Figure 16. Conducted Spurious Emissions, Plan A Band 1, Inband	24
Figure 17. Conducted Spurious Emissions, Plan A Band 1, 2.4835 – 24.2GHz	25
Figure 18. Conducted Spurious Emissions, Plan A Band 2, 30MHz - 1GHz	26
Figure 19. Conducted Spurious Emissions, Plan A Band 2, 1GHz – 2.4GHz.....	27
Figure 20. Conducted Spurious Emissions, Plan A Band 2, Inband	28
Figure 21. Conducted Spurious Emissions, Plan A Band 2, 2.4835 – 24.3GHz	29
Figure 22. Conducted Spurious Emissions, Plan A Band 3, 30MHz - 1GHz	30
Figure 23. Conducted Spurious Emissions, Plan A Band 3, 1GHz – 2.4GHz.....	31
Figure 24. Conducted Spurious Emissions, Plan A Band 3, Inband	32
Figure 25. Conducted Spurious Emissions, Plan A Band 3, 2.4835 – 24.3GHz	33
Figure 26. Conducted Spurious Emissions, Plan B Band 1, 30MHz - 1GHz.....	34
Figure 27. Conducted Spurious Emissions, Plan B Band 1, 1GHz – 2.4GHz.....	35
Figure 28. Conducted Spurious Emissions, Plan B Band 1, Inband.....	36
Figure 29. Conducted Spurious Emissions, Plan B Band 1, 2.4835 – 24.6GHz	37
Figure 30. Conducted Spurious Emissions, Plan B Band 2, 30MHz - 1GHz.....	38
Figure 31. Conducted Spurious Emissions, Plan A Band 2, 1GHz – 2.4GHz.....	39
Figure 32. Conducted Spurious Emissions, Plan B Band 2, Inband.....	40
Figure 33. Conducted Spurious Emissions, Plan B Band 2, 2.4835 – 24.6GHz	41
Figure 34. Conducted Spurious Emissions, Plan B Band 3, 30MHz - 1GHz.....	42
Figure 35. Conducted Spurious Emissions, Plan B Band 3, 1GHz – 2.4GHz.....	43
Figure 36. Conducted Spurious Emissions, Plan B Band 3, Inband.....	44
Figure 37. Conducted Spurious Emissions, Plan B Band 3, 2.4835 – 24.6GHz	45

1 Introduction

1.1 Compliance Statement

The Adtran, Inc. Tracer 6410 complies with the limits for a Digitally Modulated Transmitter device under FCC Part 15.247 and Industry Canada RSS-210, Issue 6.

1.2 Test Scope

Tests for radiated and conducted (at antenna terminal) emissions were performed. All measurements were performed in accordance with the 2003 version of ANSI C63.4. The measurement equipment conforms to ANSI C63.2 Specifications for Electromagnetic Noise and Field Strength Instrumentation.

1.3 Contract Information

Customer: Adtran, Inc.
901 Explorer Boulevard
Huntsville, AL 35806

Quotation Number: 62622

1.4 Test Dates

Testing was performed on the following date(s): October 13 to October 24, 2005

1.5 Test and Support Personnel

Washington Laboratories, LTD Greg Snyder, James Ritter
Client Representative Derek Foster

2 Equipment Under Test

2.1 EUT Identification & Description

ADTRAN Part #	Product Name/Description
12806410L2A	Tracer 6410 Plan A
12806410L2B	Tracer 6410 Plan B

Top Assembly #:	12806410L2 A / B
Sub Assembly #(s):	22806410-1, 2280018-18
Circuit Board #(s):	52806410-1, 5280018-18

The Adtran, Inc. Tracer 6410 operates in the 2400 to 2483.5 MHz unlicensed industrial, scientific, and medical (ISM) band, and serves as a radio frequency converter for 8xT1, 8xE1, and 10/100 Base-T Ethernet digital signals. The aggregate single-sided baseband bandwidth of the product is a maximum of 16.7 MHz, which accounts for 8xT1 plus framing overhead. Three frequency band plans are available: A1/B1, A2/B2, and A3/B3. Frequency plan A radios transmit (receive) in the lower (upper) band, while plan B radios transmit (receive) in the upper (lower) band.

Table 1. Device Summary

ITEM	DESCRIPTION
Manufacturer:	Adtran, Inc.
FCC ID:	HDCTRC6410
IC:	2250A-TRC6410
Model:	Tracer 6410
FCC Rule Parts:	§15.247
Industry Canada:	RSS210
Frequency Range:	2419 – 2465 MHz
Maximum Output Power:	500mW
Modulation:	Digital (QPSK)
Occupied Bandwidth:	15.89MHz
Keying:	Automatic
Type of Information:	Data
Number of Channels:	2 plans (A and B), 3 channels/plan
Power Output Level	Fixed
Antenna Type	Parabolic Dish Radio Waves, Inc. SP2-2.4; 21.1 dBi (Fixed Point-to-Point Installations)
Power Source & Voltage:	48Vdc

2.2 Test Configuration

The Tracer 6410 was configured with an external power adapter to provide 48Vdc. Cables with loopback connections were connected to Channels A and B, unshielded wires were connected to the alarm I/O and a 50 Ohm coaxial cable was connected to the antenna port.

The EUT firmware was set up to provide continuous random data for Direct Sequence modulation to the output connector.

Two plans are available: “A” and “B”. Changing between the plans is accomplished by switching the internal diplexer cables. The channels are then programmed within the plan.

A laptop PC was used to set up the EUT via Hyperterminal. The PC is only used for configuration and was removed during testing.

I/O ports available on the Tracer 6410:

Port ID	Connector Type	Cable Length (m)	Shielded (Y/N)	Connected To/From
RF Port	N	2m	Shielded	Connected to antenna
T1 (8)	RJ-45	1m	N	Un-terminated
Network	RJ-45	1m	N	Un-terminated
Craft Port	DB-9	1m	Y	Un-terminated
Alarm	3-Pin Header	1m	N	Discrete/un-terminated wires
Power	2-Pin Hader	1m	N	To AC/DC Power supply

2.3 Testing Algorithm

The Tracer 6410 was operated continuously by a firmware test sequence that provided a continuous modulated RF data stream to the output port. For the conducted power measurements the transmitter was set to the maximum output power setting of 27dBm. During the radiated emissions testing the transmitter was adjusted to 25dBm so as not to exceed the 36dBm EIRP limit.

Worst case emission levels are provided in the test results data.

2.4 Test Location

All measurements herein were performed at Washington Laboratories, Ltd. test center in Gaithersburg, MD. Site description and site attenuation data have been placed on file with the FCC's Sampling and Measurements Branch at the FCC laboratory in Columbia, MD. The Industry Canada OATS numbers are 3035A-1 and 3035A-2 for Washington Laboratories, Ltd. Site 1 and Site 2, respectively. Washington Laboratories, Ltd. has been accepted by the FCC and approved by NIST NVLAP (NVLAP Lab Code: 200066-0) as an independent FCC test laboratory.

2.5 Measurements

2.5.1 References

ANSI C63.2 Specifications for Electromagnetic Noise and Field Strength Instrumentation

ANSI C63.4 American National Standard for Methods of Measurement of Radio-Noise Emissions from Low-Voltage Electrical and Electronic Equipment in the Range of 9 kHz to 40 GHz

2.6 Measurement Uncertainty

All results reported herein relate only to the equipment tested. For the purposes of the measurements performed by Washington Laboratories, the measurement uncertainty is ± 2.3 dB. This has been calculated for a *worst-case situation* (radiated emissions measurements performed on an open area test site).

The following measurement uncertainty calculation is provided:

$$\text{Total Uncertainty} = (A^2 + B^2 + C^2)^{1/2}/(n-1)$$

where:

A = Antenna calibration uncertainty, in dB = 2 dB

B = Spectrum Analyzer uncertainty, in dB = 1 dB

C = Site uncertainty, in dB = 4 dB

n = number of factors in uncertainty calculation = 3

Thus, Total Uncertainty = $0.5 (2^2 + 1^2 + 4^2)^{1/2} = \pm 2.3$ dB.

3 Test Equipment

Table 2 shows a list of the test equipment used for measurements along with the calibration information.

Table 2: Test Equipment List

WLL Asset #	Manufacturer Model/Type	Function	Cal. Due
0073	HP 8568B	SPECTRUM ANALYZER	6/30/2006
0007	ARA LPB-2520	BICONILOG ANTENNA	12/25/2005
0522	HEWLETT-PACKARD 8449B	MICROWAVE PREAMP	4/11/2006
0425	ARA DRG118/A	MICROWAVE HORN ANTENNA	10/31/2005
0125	SOLAR 8012-50-R-24-BNC	LISN	10/31/2005
0126	SOLAR 8012-50-R-24-BNC	LISN	10/31/2005
0210	NARDA V638	HORN ANTENNA	12/25/2008
0476	TEKTRONIX TDS 220	OSCILLOSCOPE	8/2/2006
0475	WILTRON 75N50	DIODE DETECTOR	12/31/2005
0394	HEWLETT-PACKARD 438A	POWER METER	3/21/2006
0390	HEWLETT-PACKARD 8481B	POWER HEAD	3/21/2006
0026	EMCO 3110B	BICONICAL ANTENNA	12/10/2005
0029	EMCO 3146A	LOG PERIODIC ANTENNA	6/28/2006
0071	HP 85685A	RF PRESELECTOR	6/30/2006
0478	ROHDE & SCHWARZ SMT06	SIGNAL GENERATOR	11/23/2005
0069	HP 85650A	QUASI-PEAK ADAPTER	6/30/2006

4 Test Results

4.1 RF Power Output: (§15.247(b) and RSS-210, A8.4)

For devices within the scope of FCC §15.247 and RSS-210 Annex A, the peak power conducted from the intentional radiator to the antenna shall not be greater than one watt (30 dBm).

The output from the transmitter was connected to a diode detector and oscilloscope. The peak deflection was measured on the oscilloscope and recorded. A signal generator was then substituted in place of EUT and set to the same frequency as the transmitter. The CW output of the signal generator was increased until the same deflection was noted on the oscilloscope. A power meter was then connected to the output of the signal generator to determine the output power of the signal generator. This level is then recorded as the output power of the EUT at the specified frequency.

The EUT carrier was modulated during this test.

Table 3. RF Power Output

Channel and/or Frequency	Measured Level (dBm)	Measured Level (mWatts)	Rated (mWatts)	Limit (mWatts)
Plan A Band 1 – 2419 MHz	26.85	484	500	1000
Plan A Band 2 – 2422 MHz	26.92	492	500	1000
Plan A Band 3 – 2425 MHz	26.93	494	500	1000
Plan B Band 1 – 2459 MHz	26.78	475	500	1000
Plan B Band 2 – 2462 MHz	26.93	494	500	1000
Plan B Band 3 – 2465 MHz	26.96	495	500	1000

**RF Output Power Measurement
Diode Detector Method Test Setup Diagram**

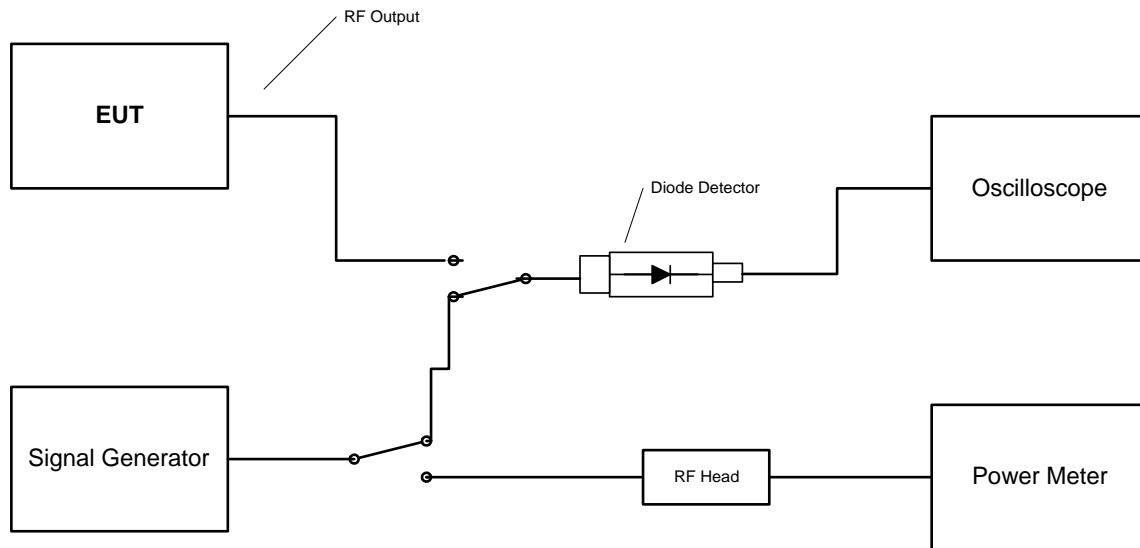

Figure 1. Power Measurement Setup

4.2 Occupied Bandwidth: (§15.247(a)(2) and RSS-210 Section A8.2)

For systems using digital modulation techniques, FCC Part 15.247 and Annex A of RSS-210 requires that the minimum 6dB bandwidth be at least 500 kHz.

Occupied bandwidth was performed by connecting the RF output of the EUT to the input of a spectrum analyzer. The following plots depict the bandwidth measurements. Table 4 lists the measured bandwidths.

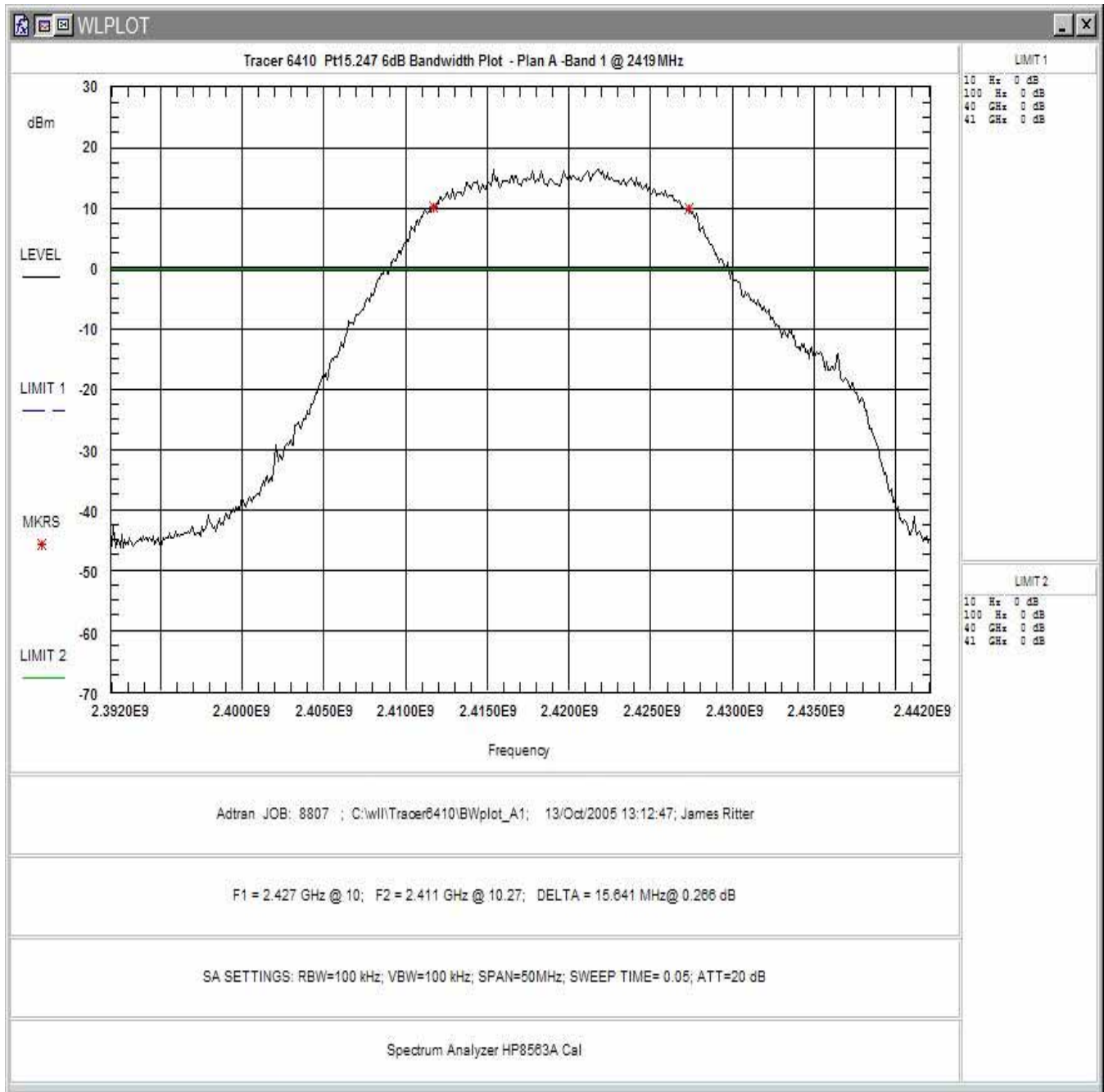

Figure 2. Occupied Bandwidth - Plan A, Band 1

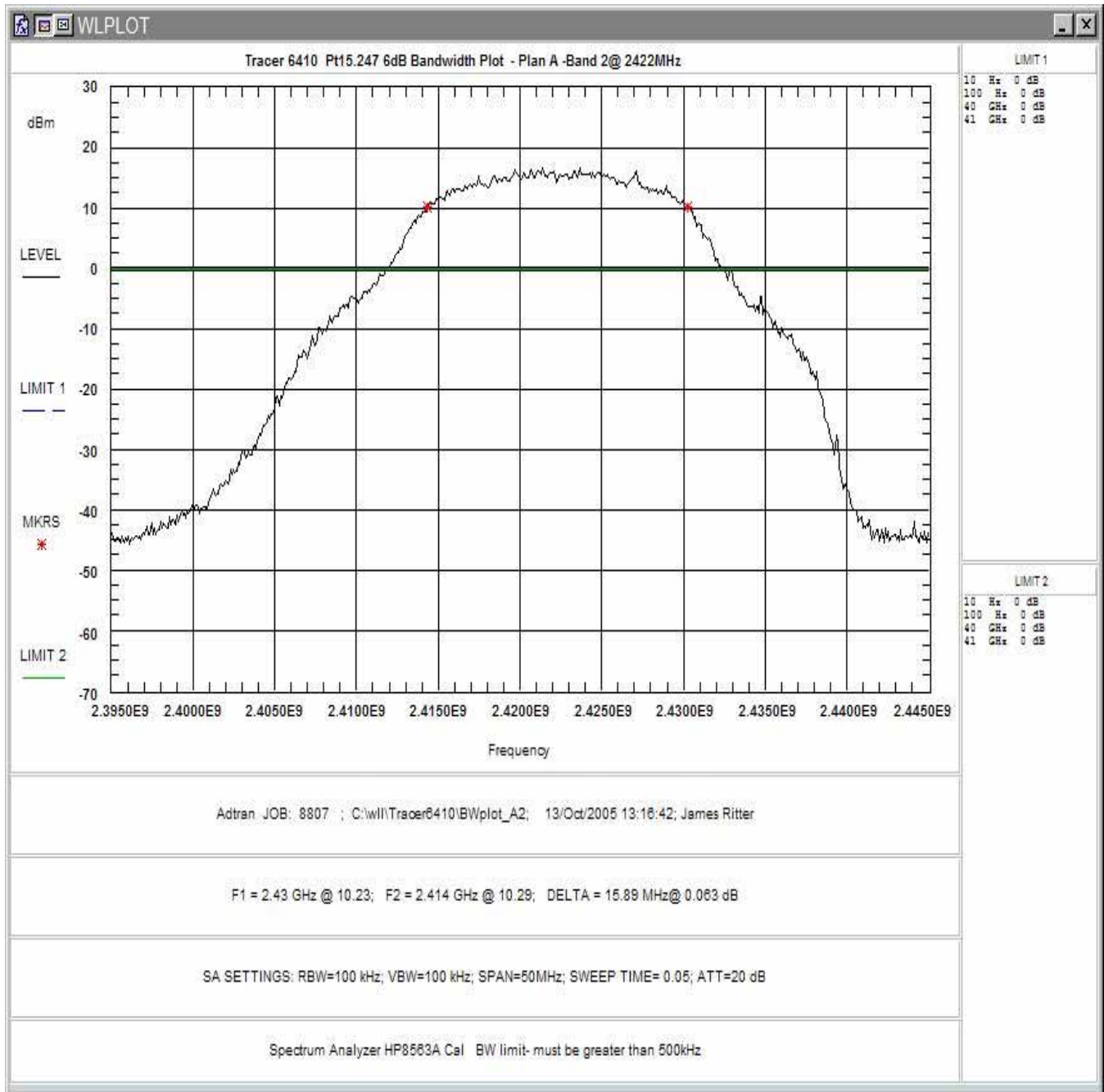

Figure 3. Occupied Bandwidth - Plan A, Band 2

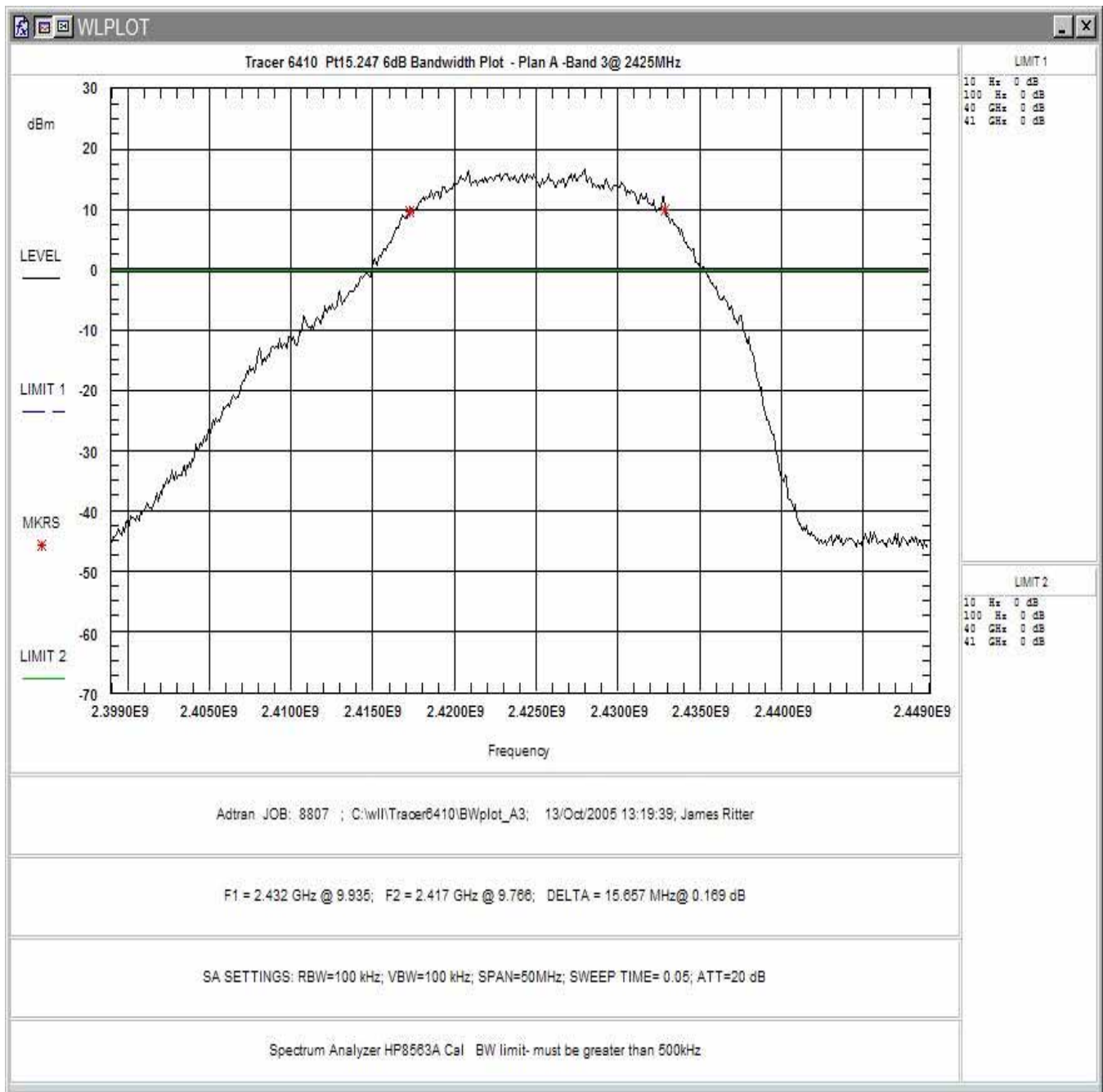

Figure 4. Occupied Bandwidth - Plan A, Band 3

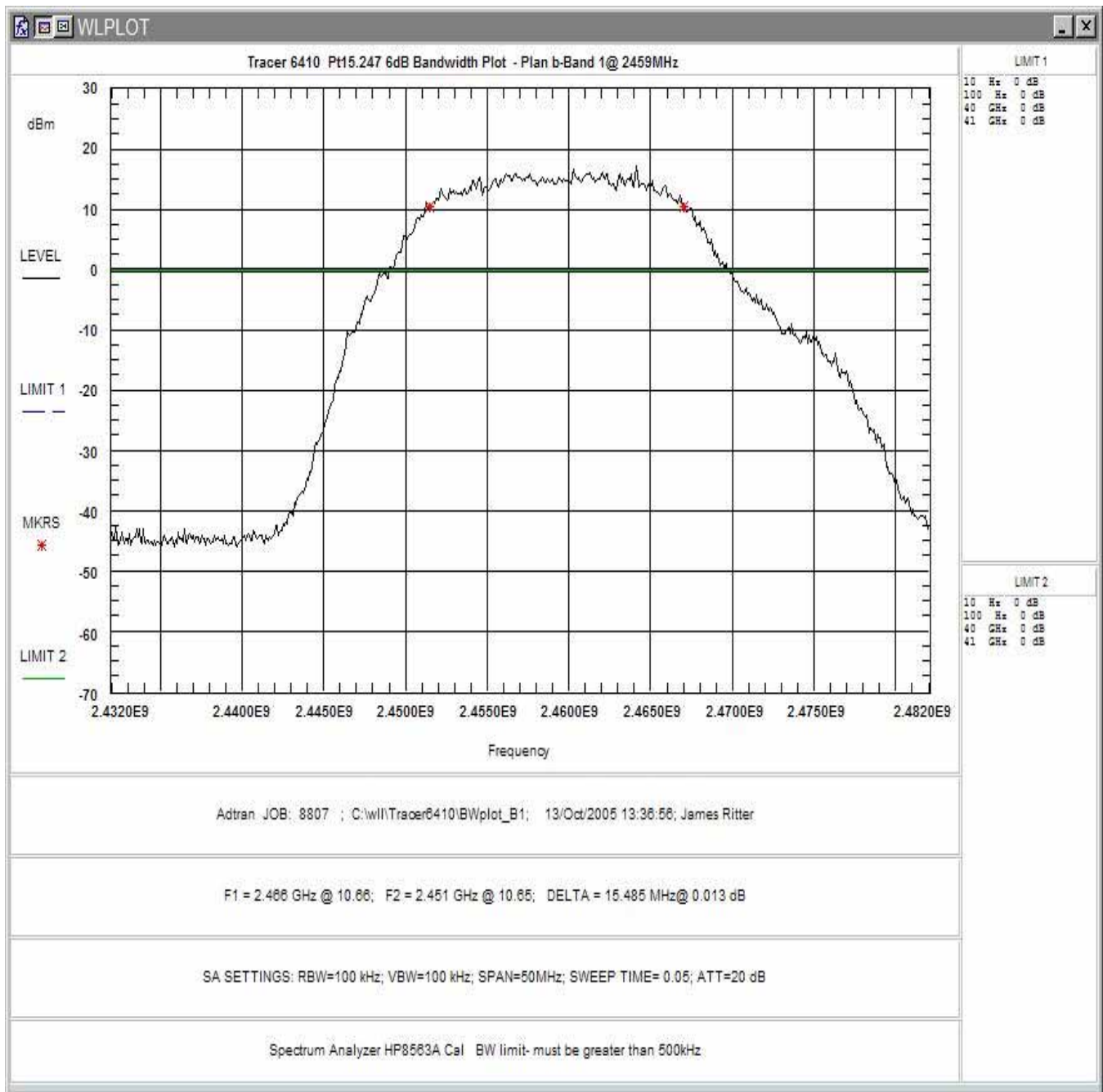

Figure 5. Occupied Bandwidth - Plan B, Band 1

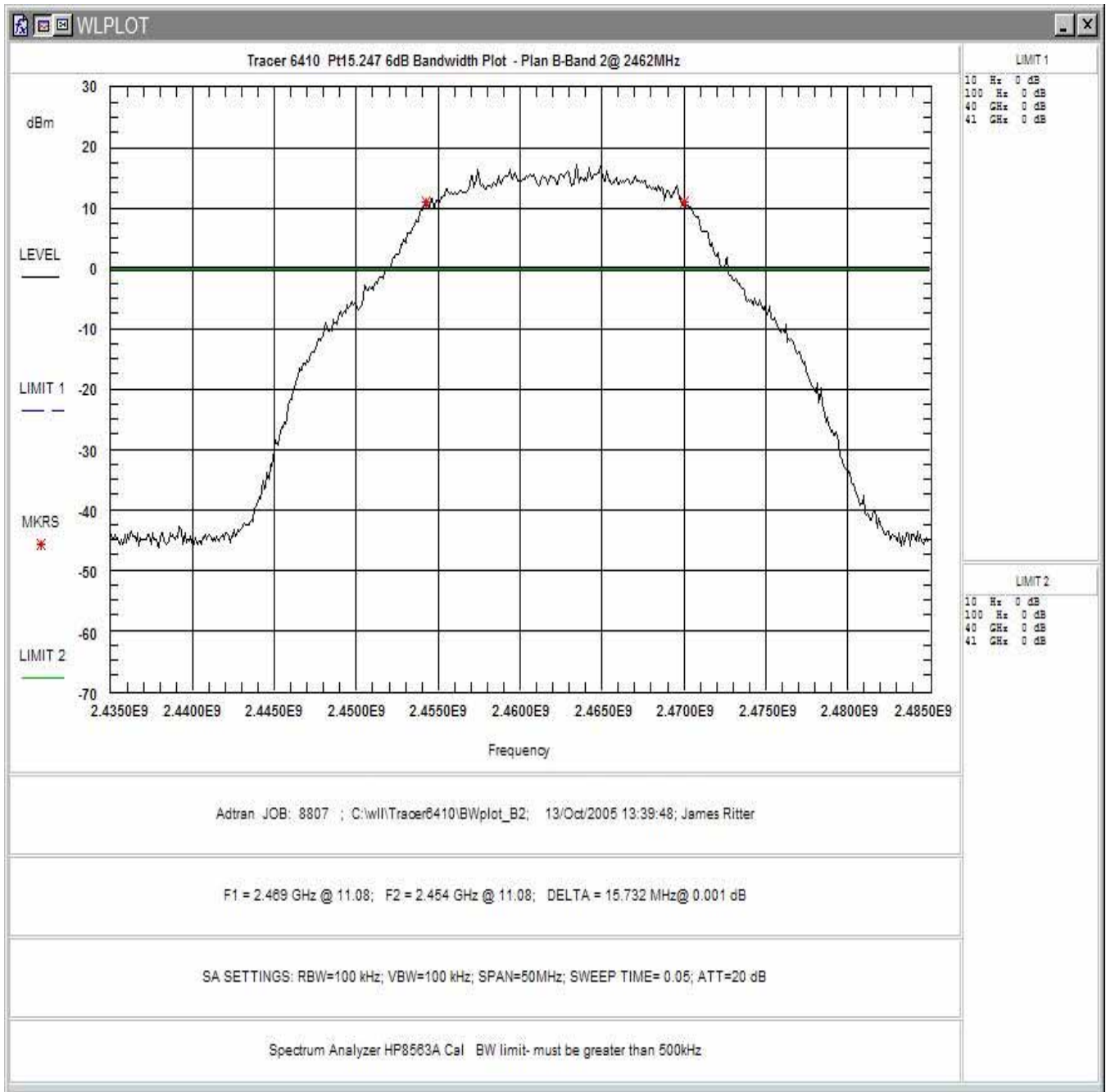

Figure 6. Occupied Bandwidth - Plan B, Band 2

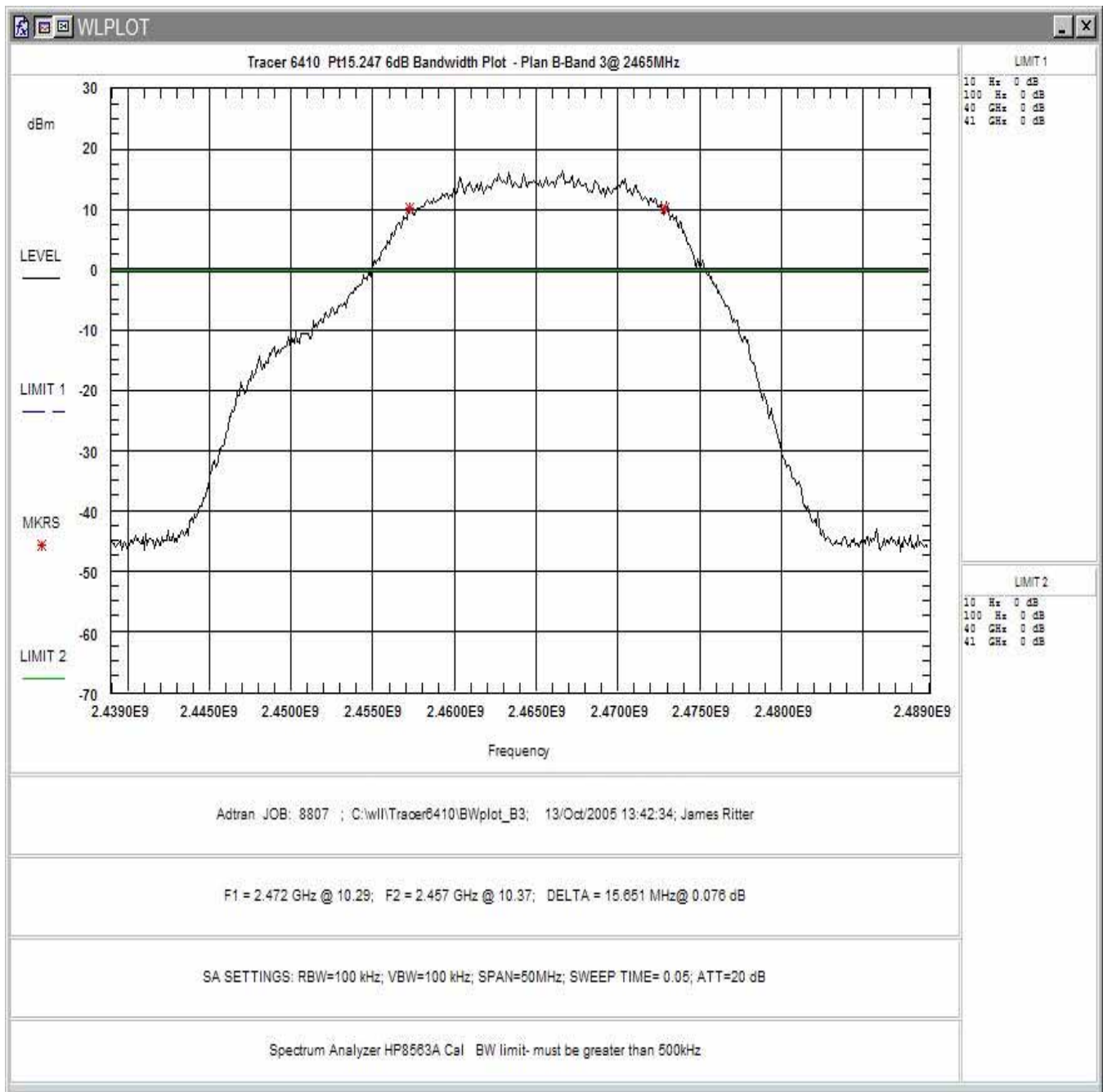

Figure 7. Occupied Bandwidth - Plan B, Band 3

Table 4 provides a summary of the Occupied Bandwidth Results.

Table 4. Occupied Bandwidth Results

Frequency	Bandwidth	Limit	Pass/Fail
Plan A (1)	15.64	> 500 kHz	Pass
Plan A (2)	15.89	> 500 kHz	Pass
Plan A (3)	15.65	> 500 kHz	Pass
Plan B (1)	15.48	> 500 kHz	Pass
Plan B (2)	15.73	> 500 kHz	Pass
Plan B (3)	15.65	> 500 kHz	Pass

4.3 RF Peak Power Spectral Density (§15.247(e) and RSS-210, Annex 8.2)

For digitally modulated systems, the peak power spectral density conducted from the intentional radiator to the antenna shall not be greater than 8 dBm in any 3 kHz band during any time interval of continuous transmission.

The output from the transmitter was connected to an attenuator and then to the input of the RF Spectrum Analyzer. The analyzer offset was adjusted to compensate for the attenuator and other losses in the system.

The highest peak within the transmission was located and measured for the upper and lower channels of Plan A and Plan B. Plots of the PSD were taken as shown in Figure 8 through Figure 13 below. Table 5 provides a summary of the data.

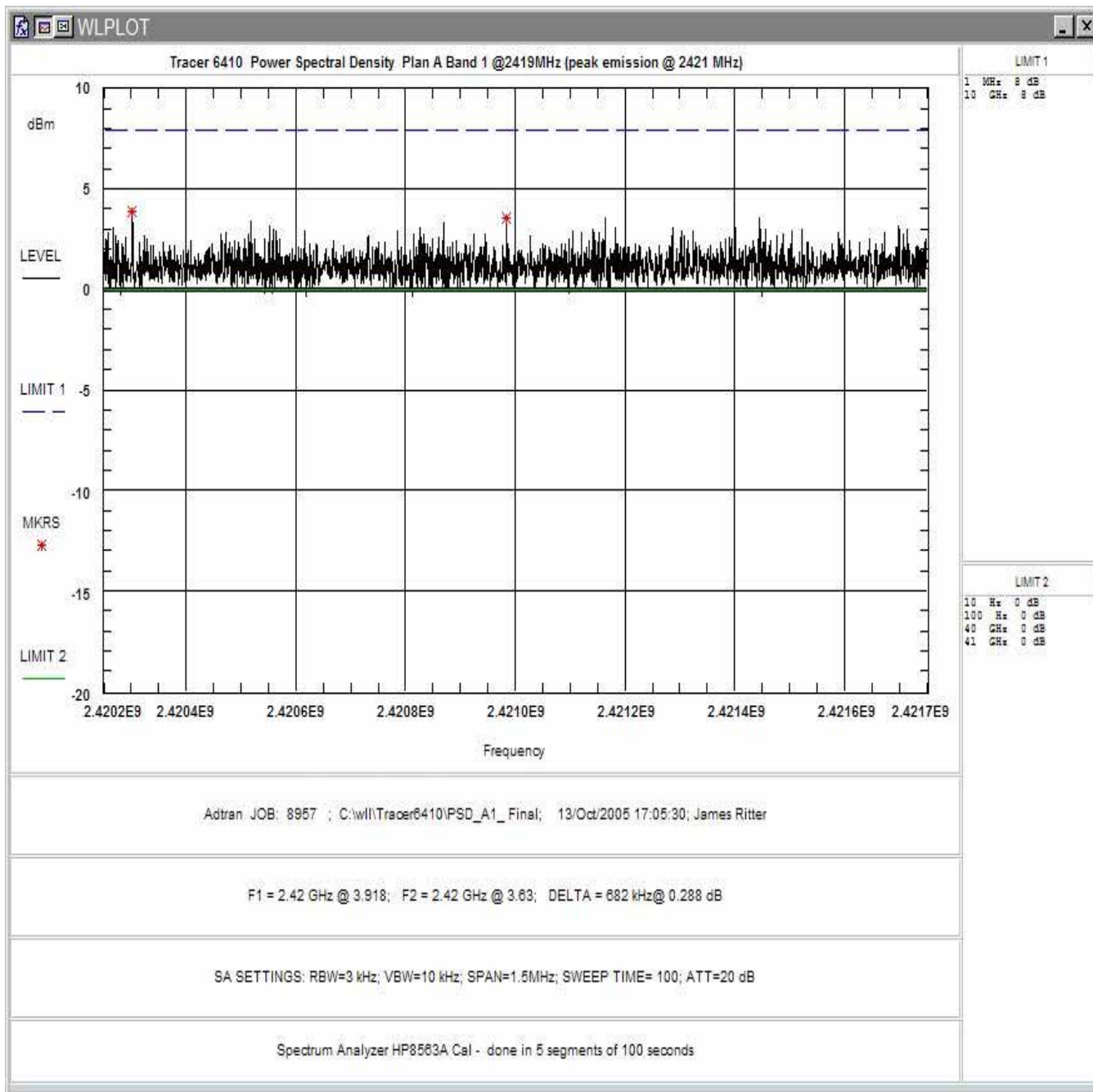

Figure 8. Power Spectral Density Plan A, Band 1

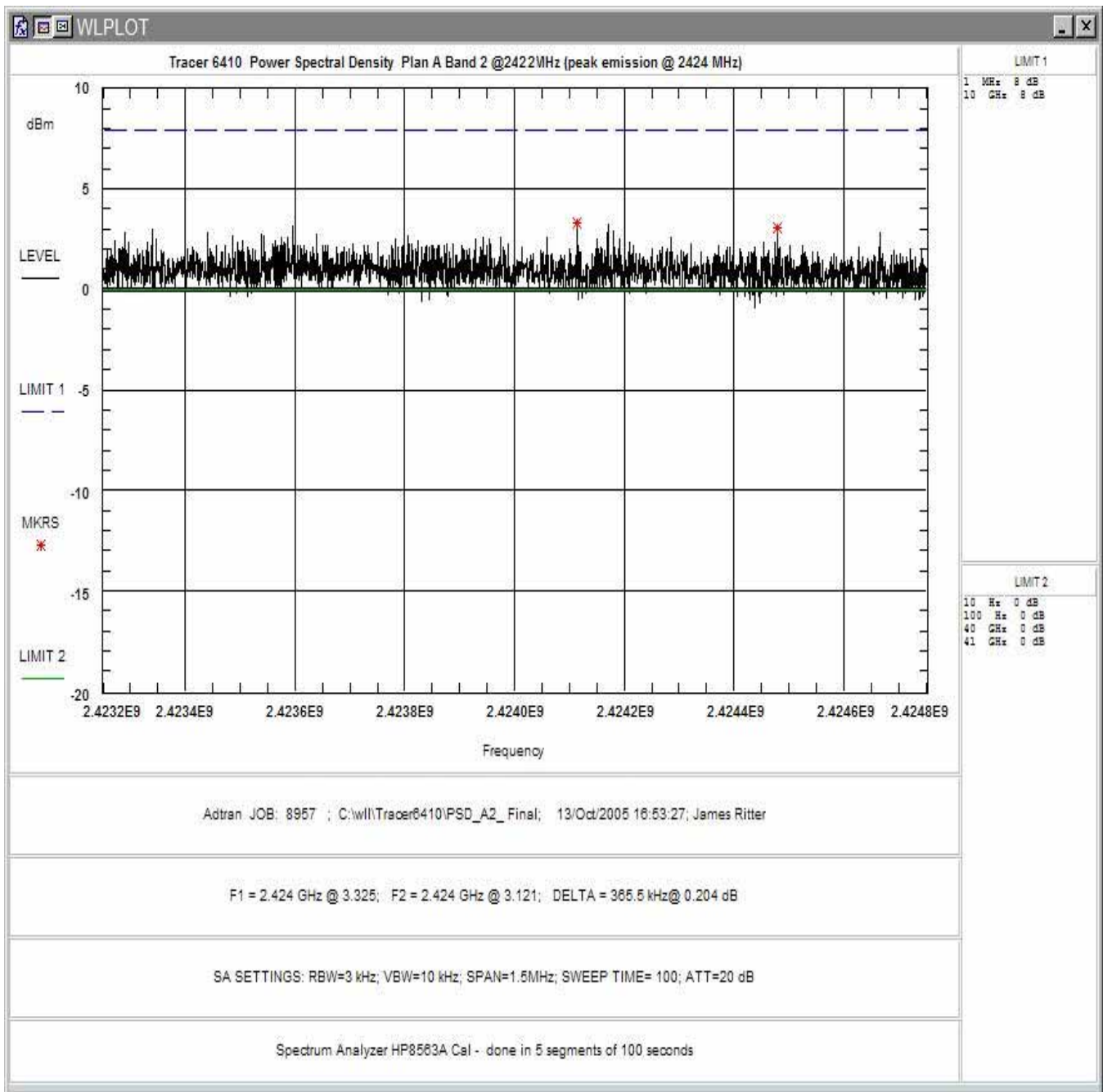

Figure 9. Power Spectral Density Plan A, Band 2

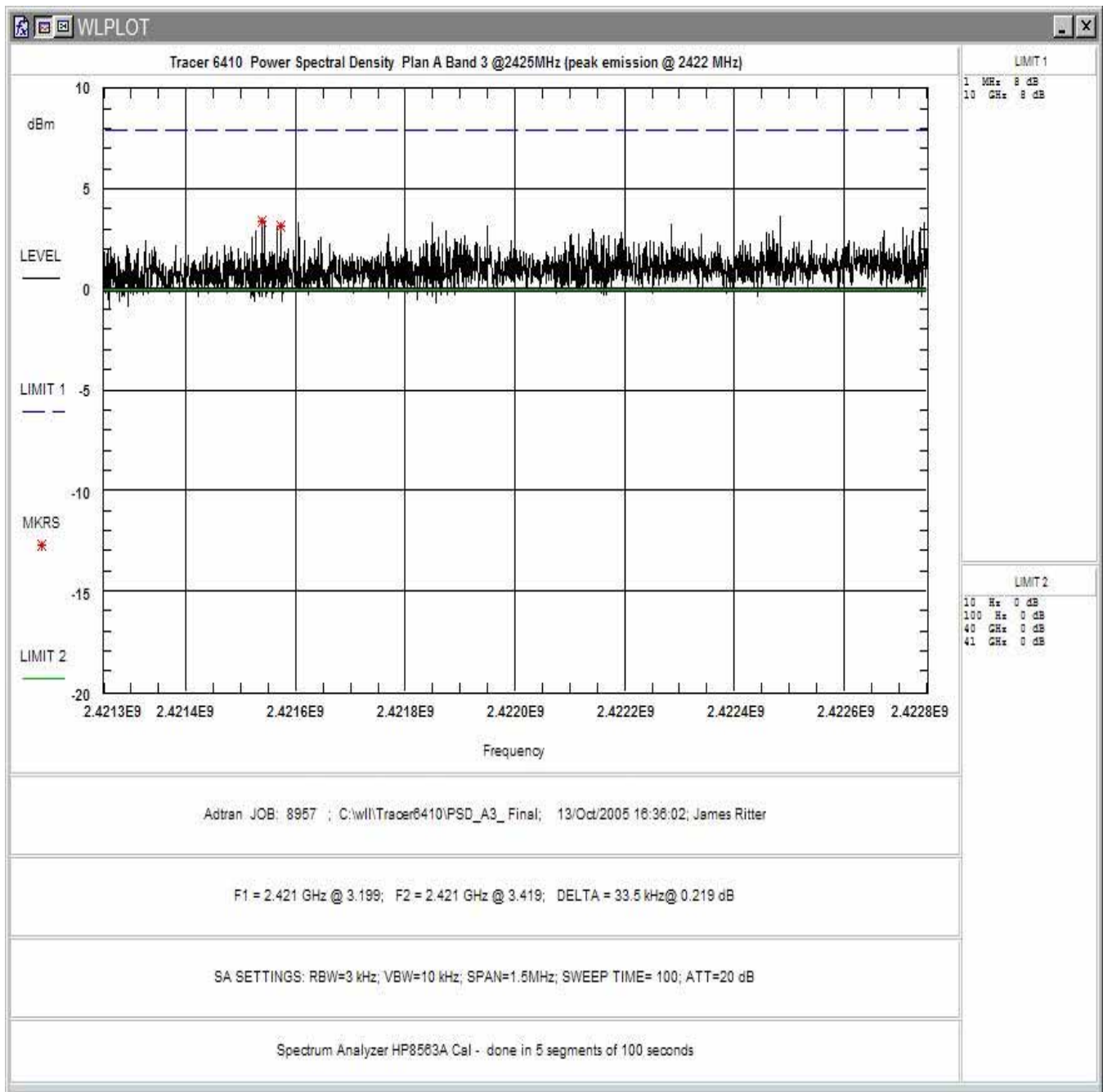

Figure 10. Power Spectral Density Plan A, Band 3

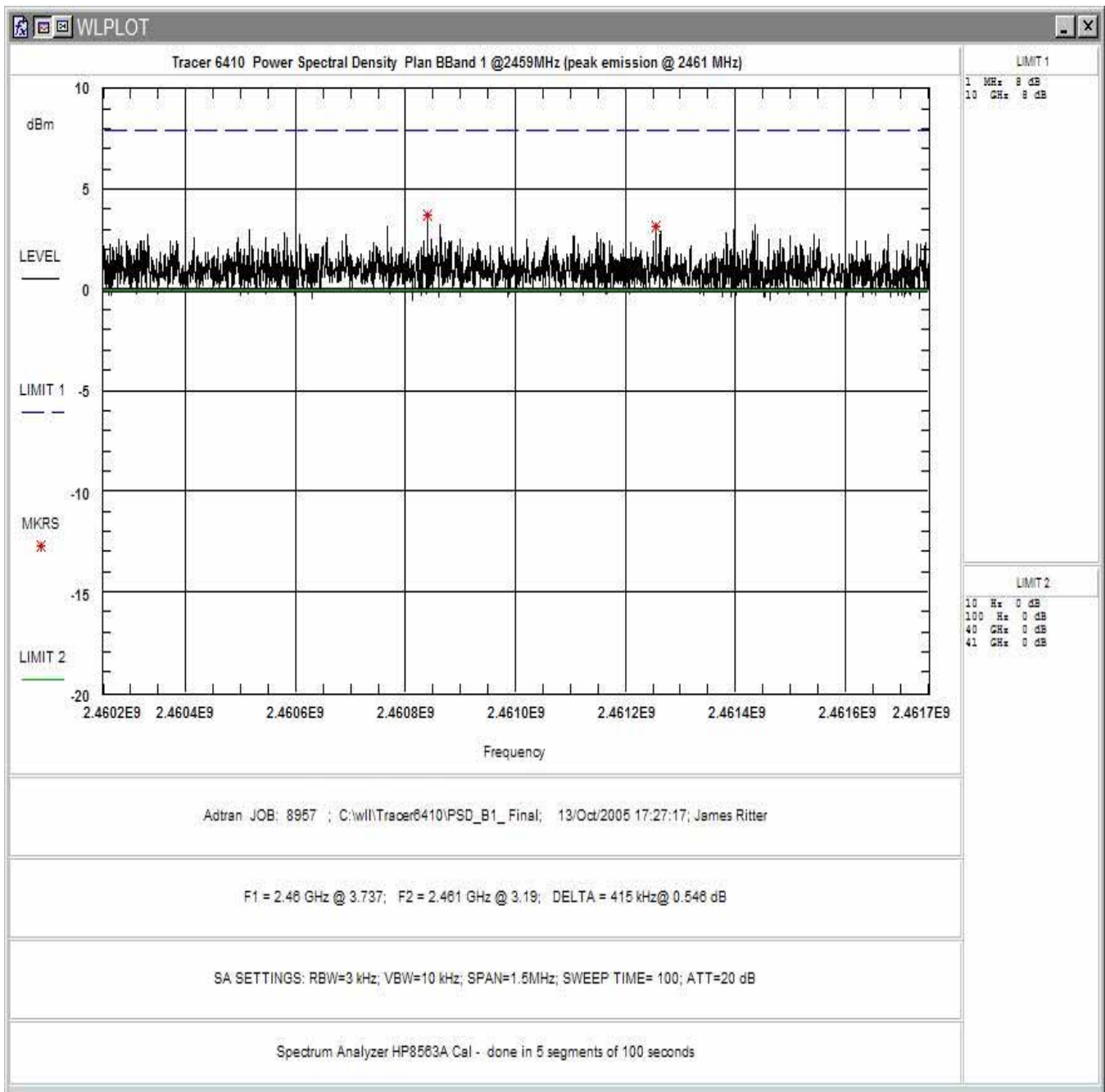

Figure 11. Power Spectral Density Plan B, Band 1

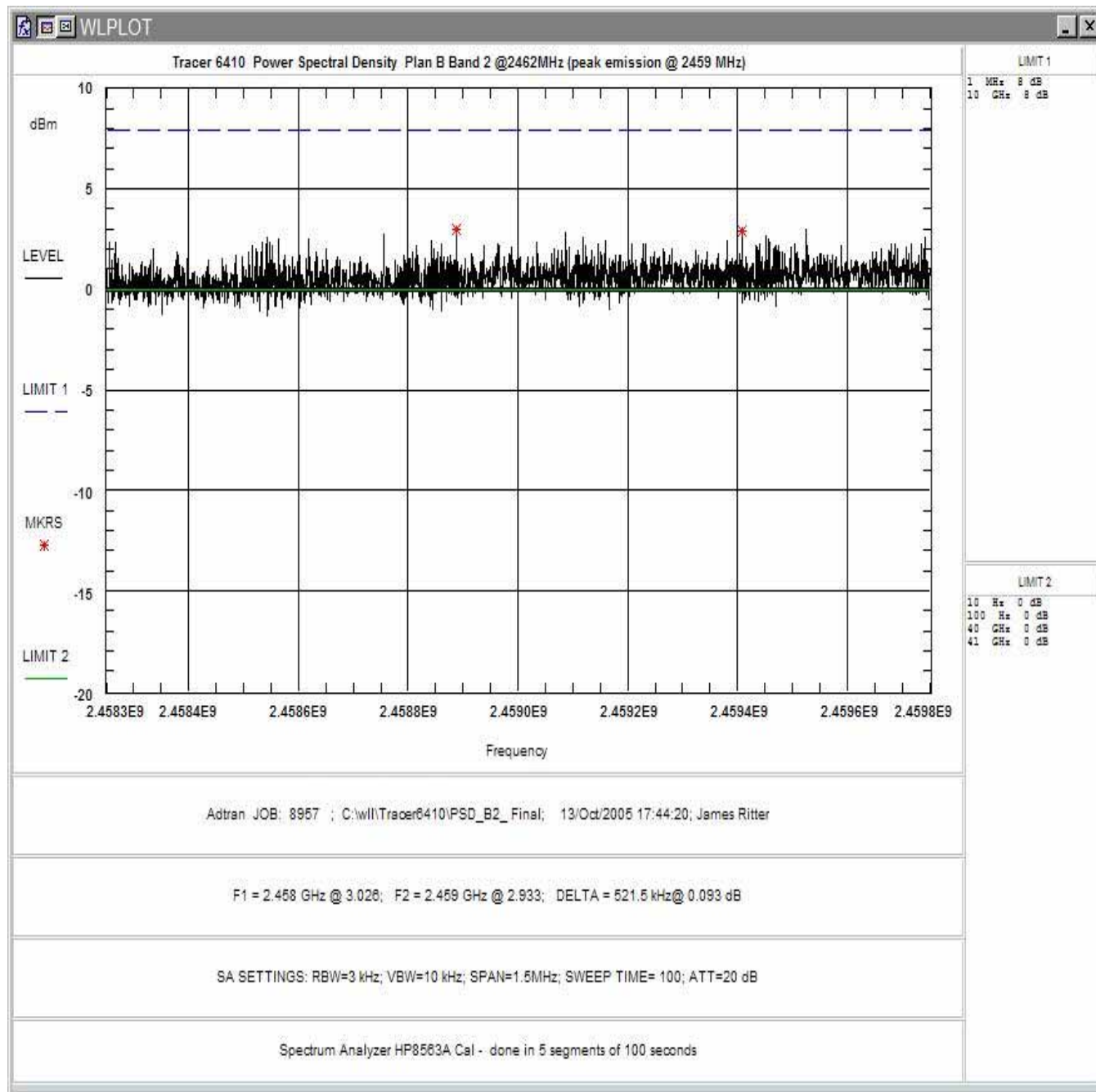

Figure 12. Power Spectral Density Plan B, Band 2

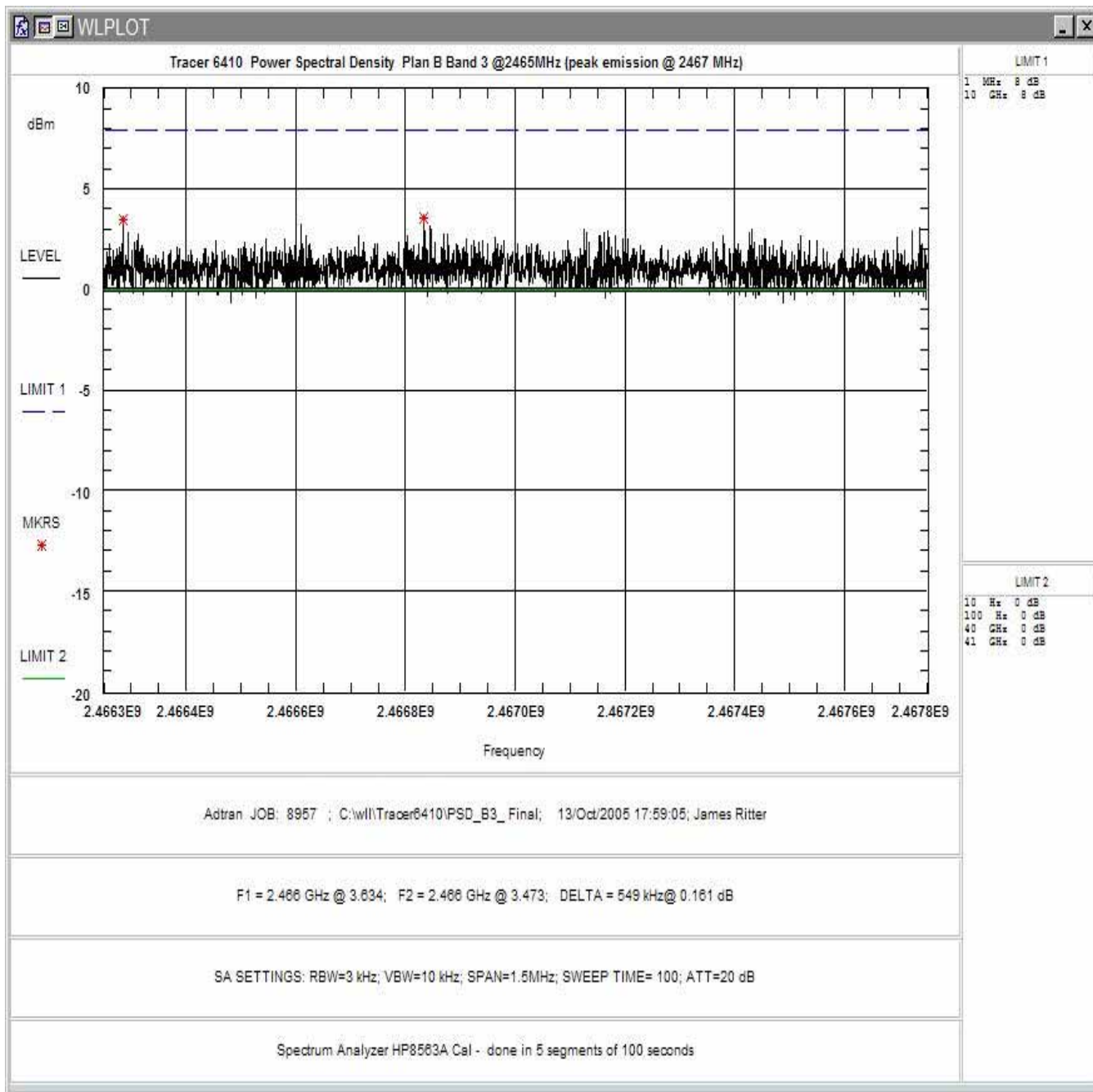

Figure 13. Power Spectral Density Plan B, Band 3

Table 5. RF Power Spectral Density

Frequency	Level (dBm)	Limit (dBm)	Pass/Fail
Plan A (1)	3.92	8	P
Plan A (2)	3.33	8	P
Plan A (3)	3.42	8	P
Plan B (1)	2.46	8	P
Plan B (2)	2.46	8	P
Plan B (3)	2.47	8	P

4.4 Conducted Spurious Emissions at Antenna Terminals (FCC Part §15.247(d) and RSS-210, A8)

In any 100 kHz band outside the frequency band in which the system is operating, the RF power shall be at least 20dB below that in the 100 kHz bandwidth that contain the highest level of the desired power.

All measurements were performed with a measurement bandwidth of 100kHz. The video bandwidth was set to 3MHz during the testing.

See the plots of conducted emissions plots below.

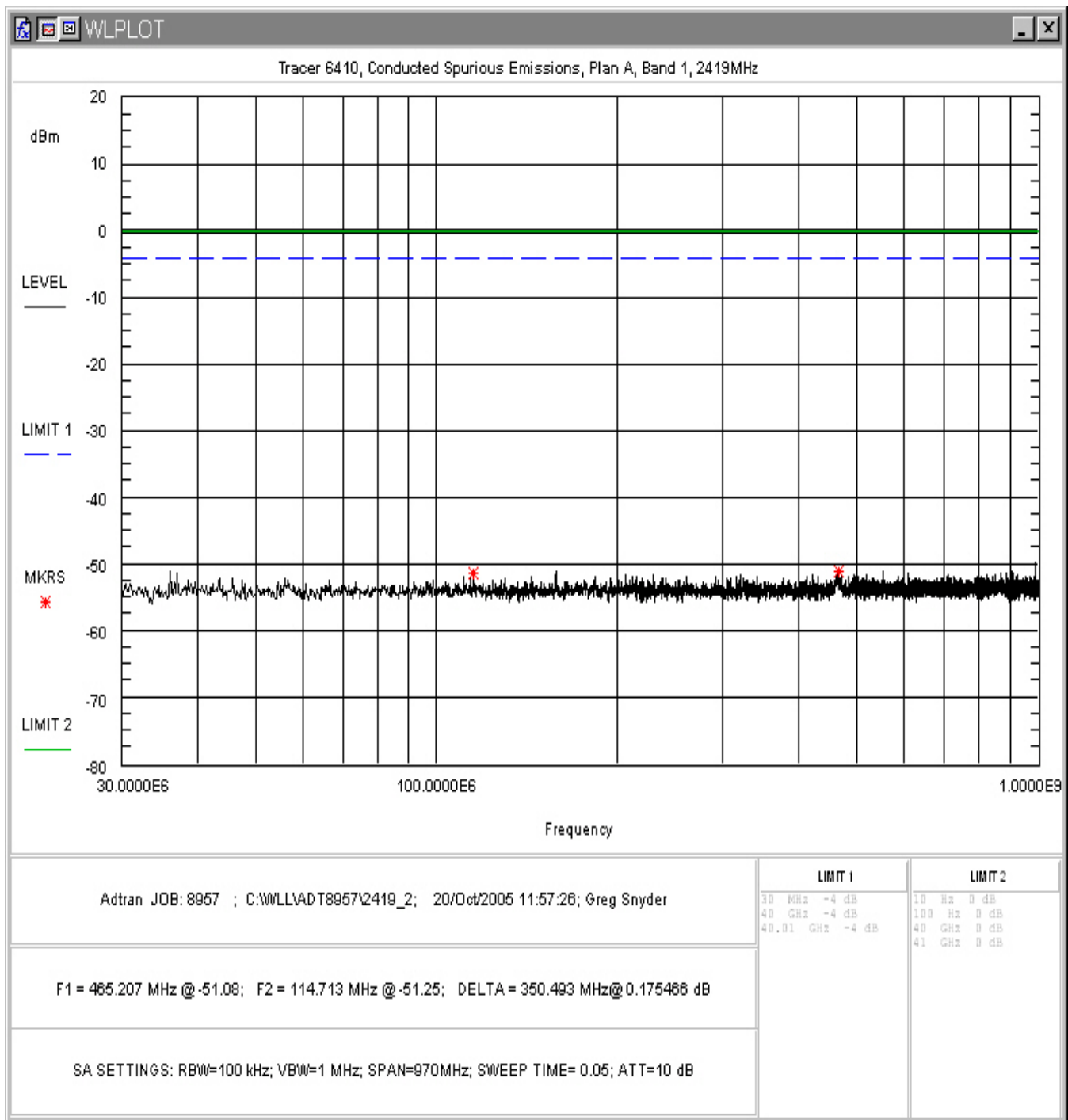

Figure 14. Conducted Spurious Emissions, Plan A Band 1, 30MHz - 1GHz

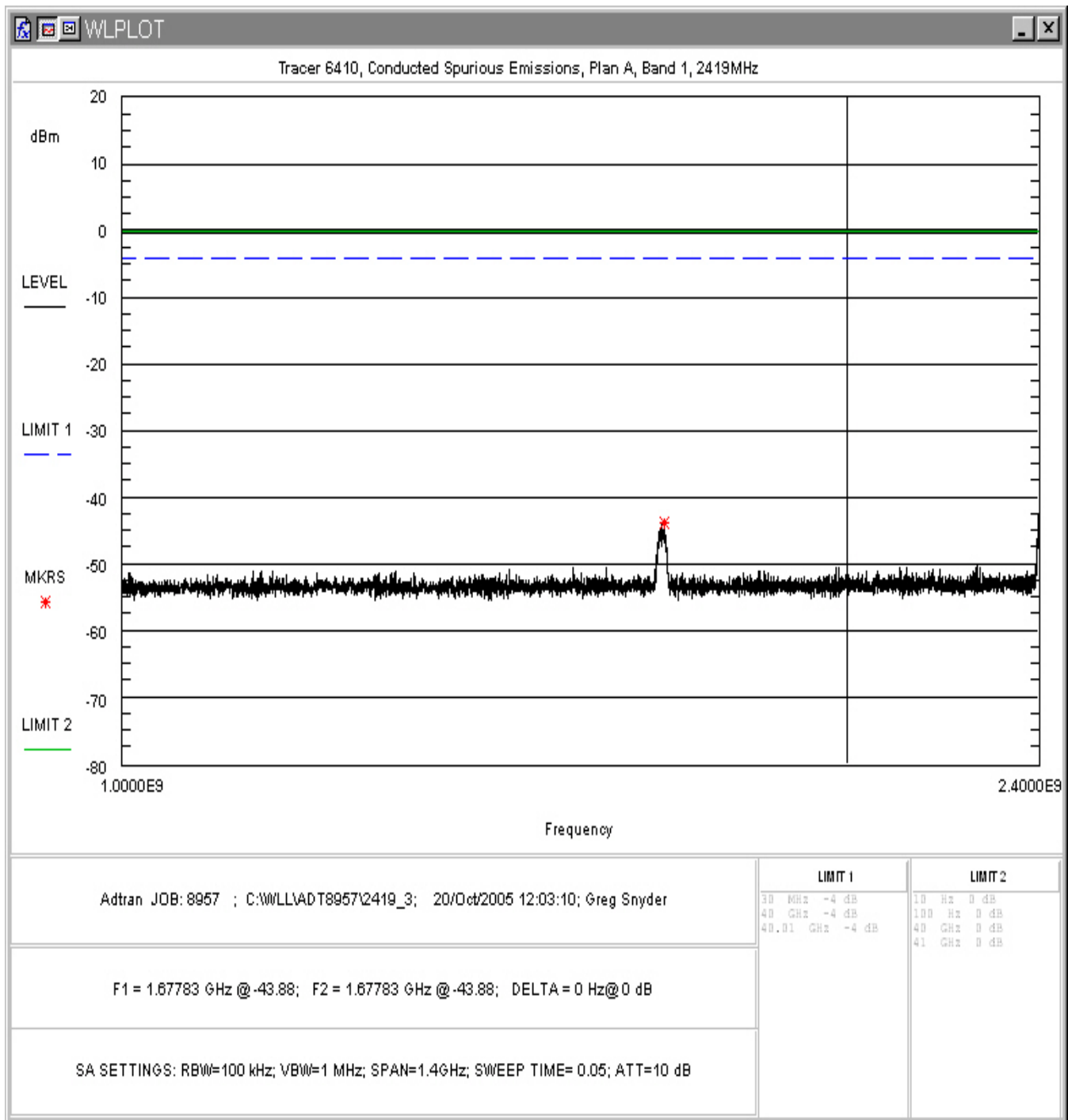

Figure 15. Conducted Spurious Emissions, Plan A Band 1, 1GHz – 2.4GHz

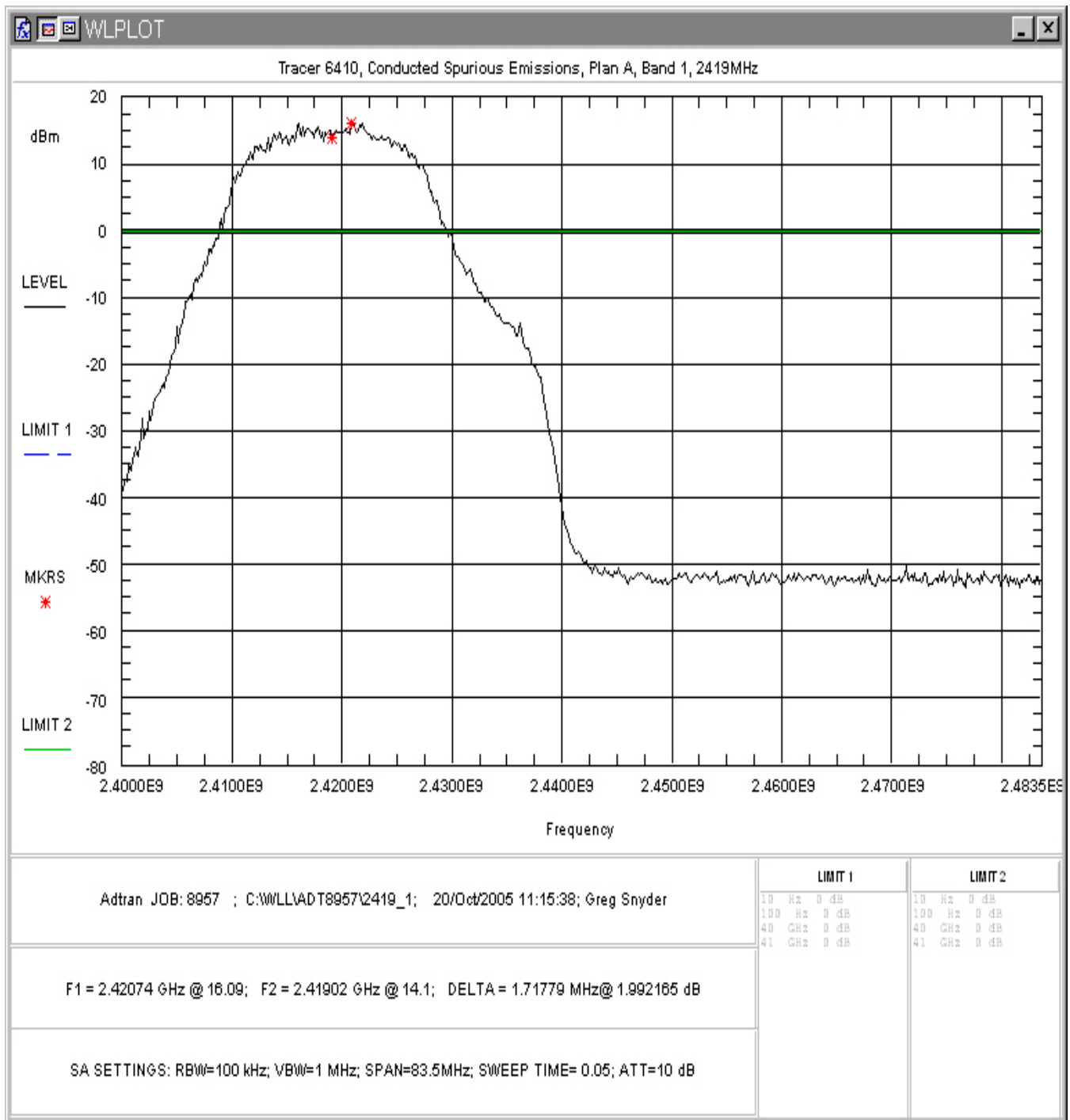

Figure 16. Conducted Spurious Emissions, Plan A Band 1, Inband

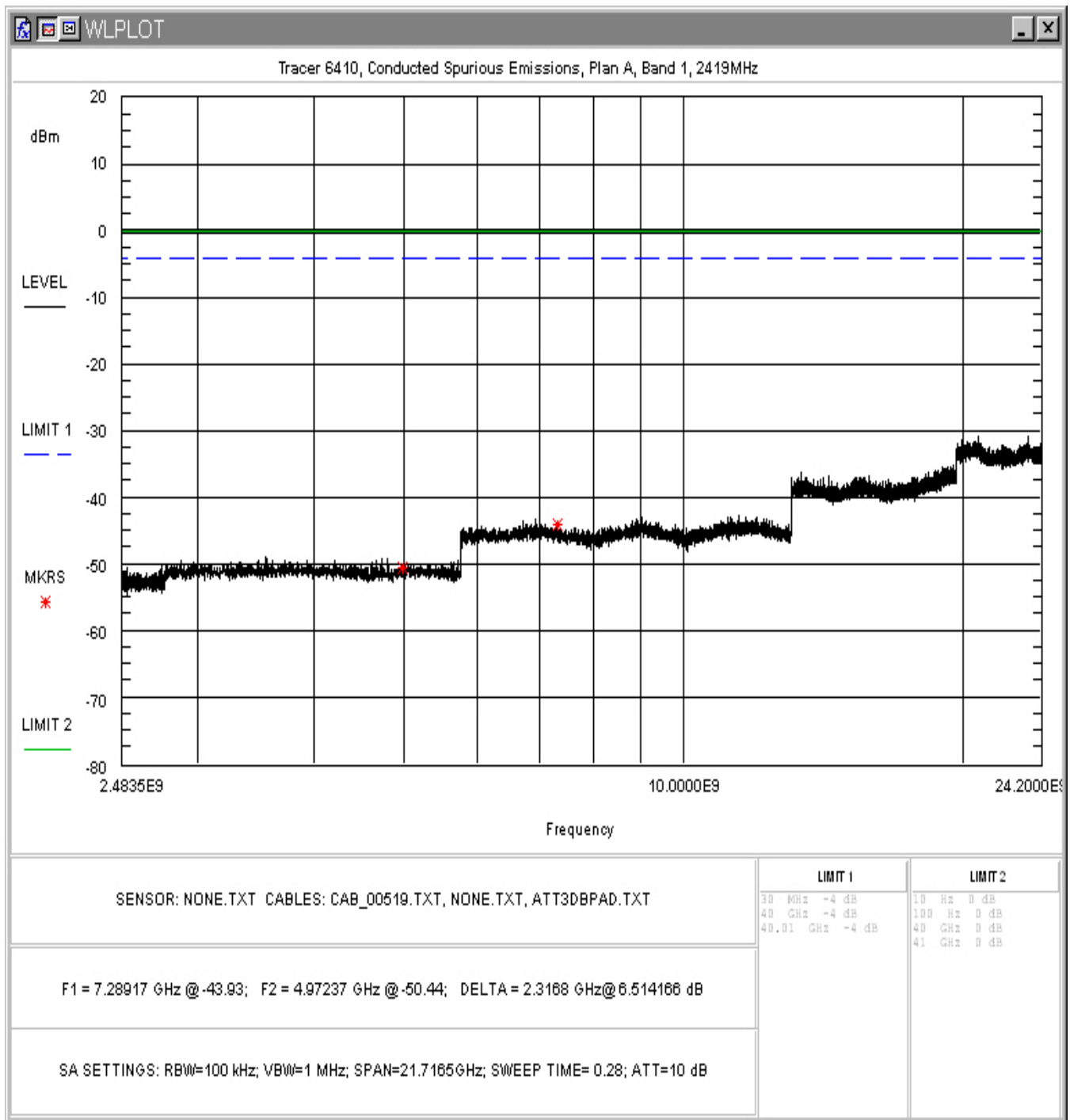

Figure 17. Conducted Spurious Emissions, Plan A Band 1, 2.4835 – 24.2GHz

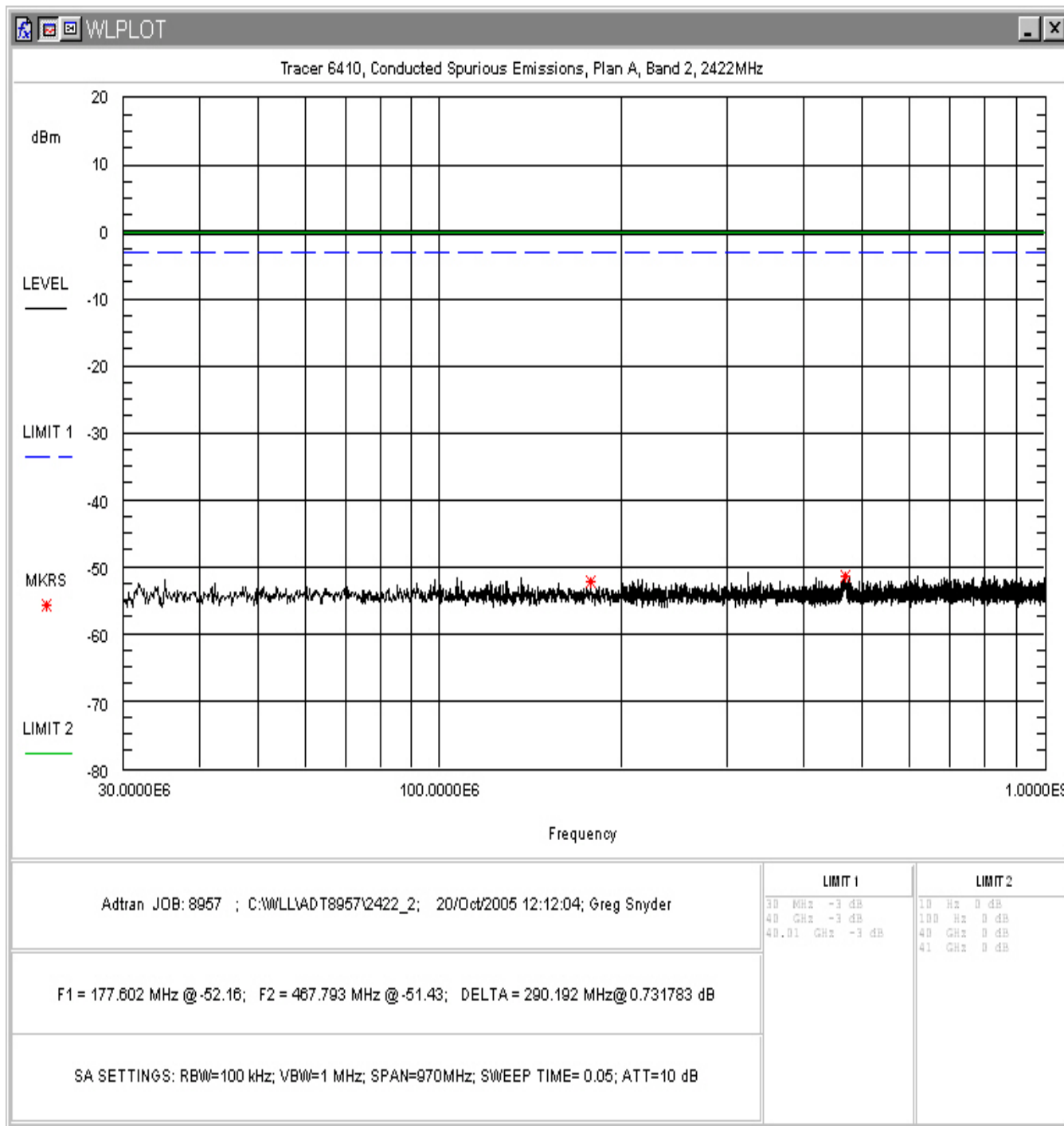

Figure 18. Conducted Spurious Emissions, Plan A Band 2, 30MHz - 1GHz

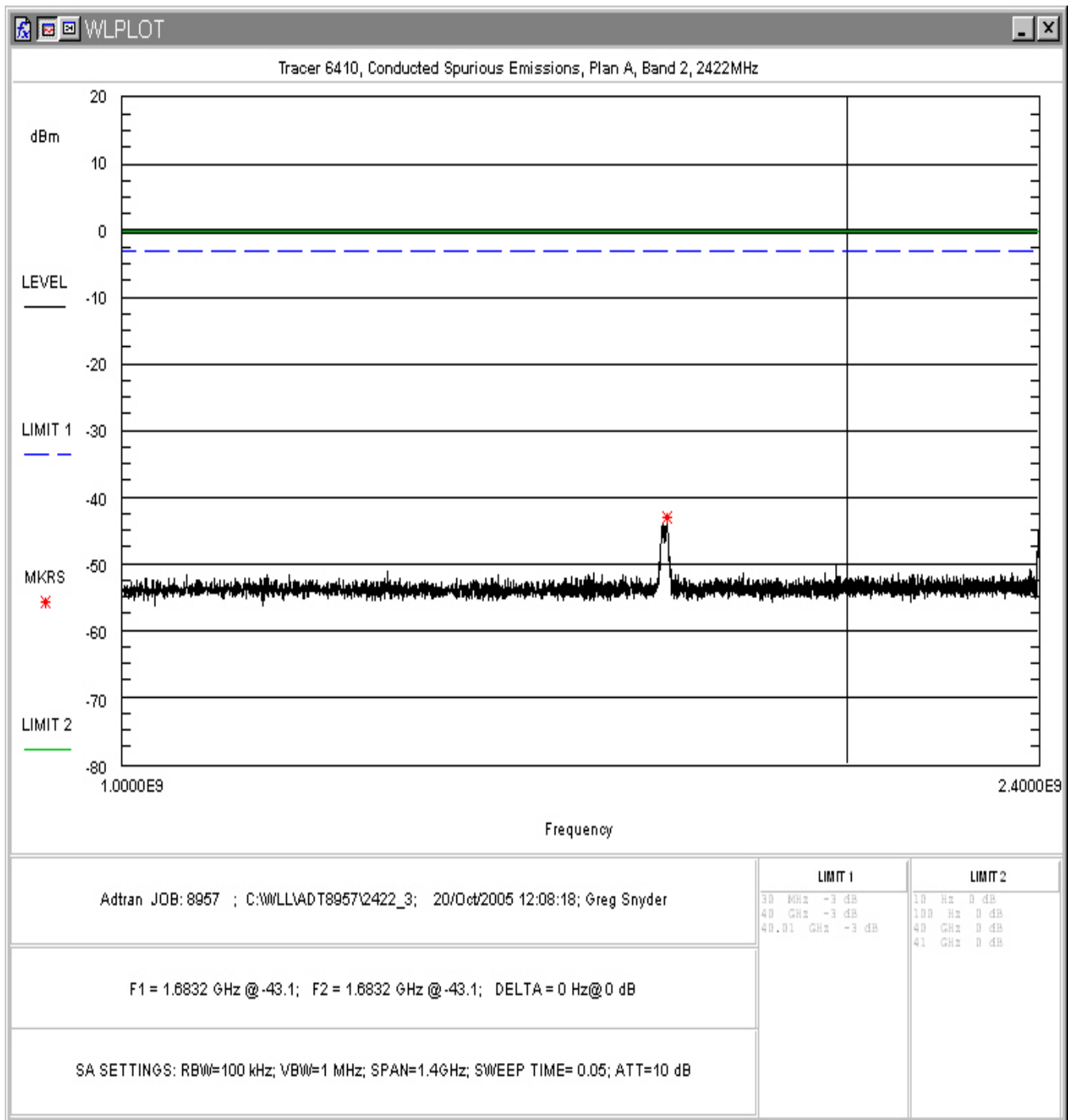

Figure 19. Conducted Spurious Emissions, Plan A Band 2, 1GHz – 2.4GHz

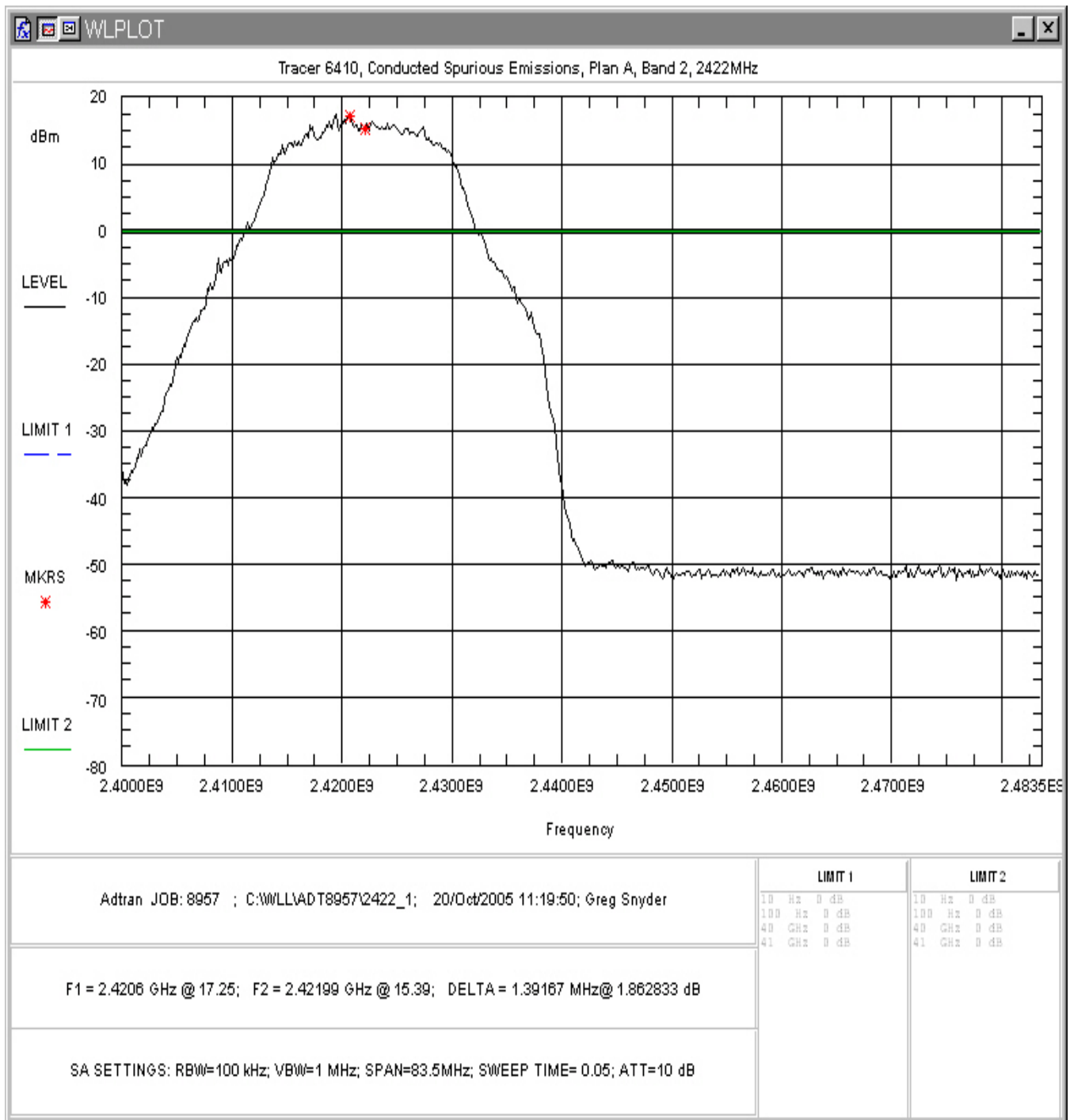

Figure 20. Conducted Spurious Emissions, Plan A Band 2, Inband

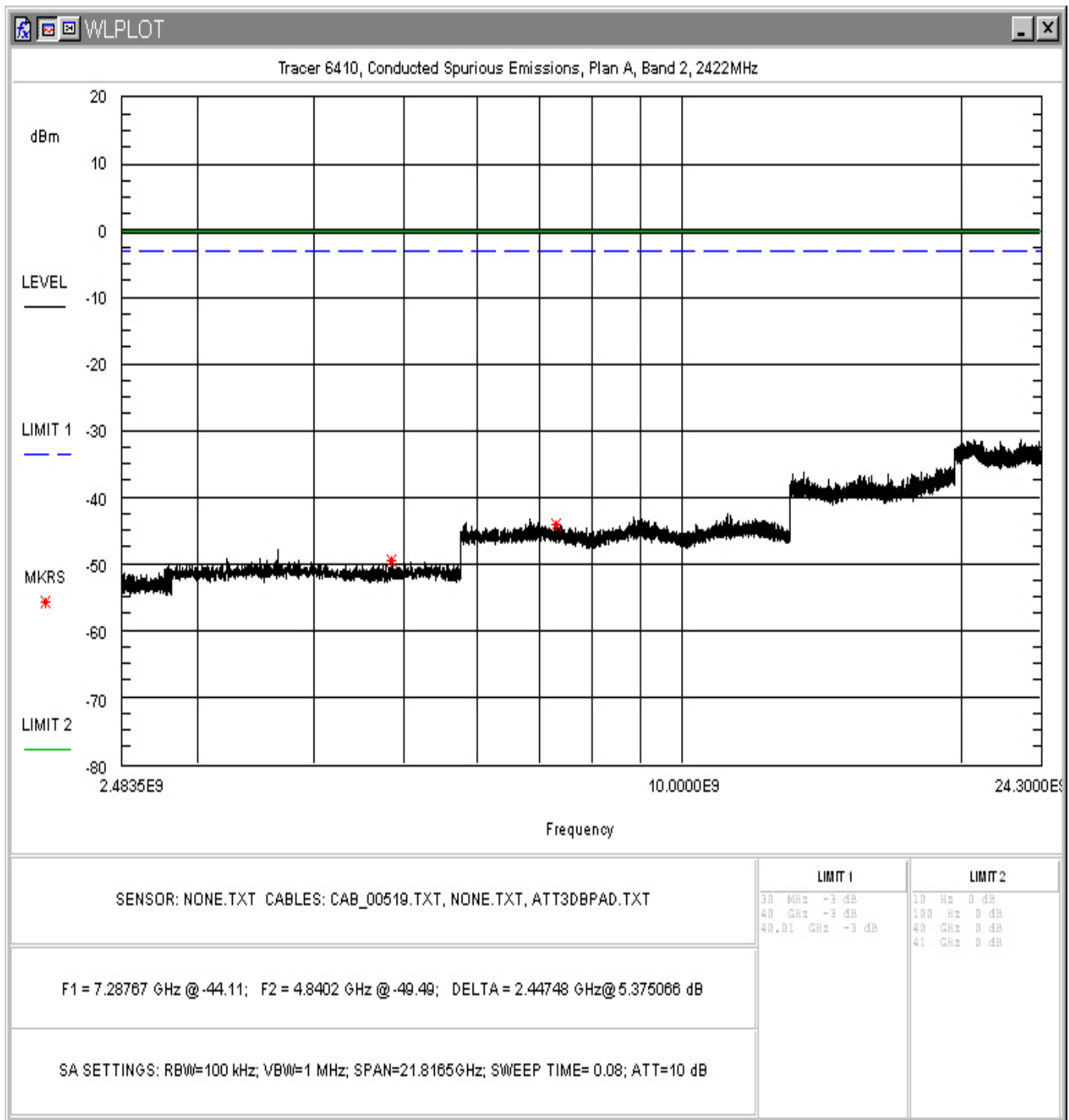

Figure 21. Conducted Spurious Emissions, Plan A Band 2, 2.4835 – 24.3GHz

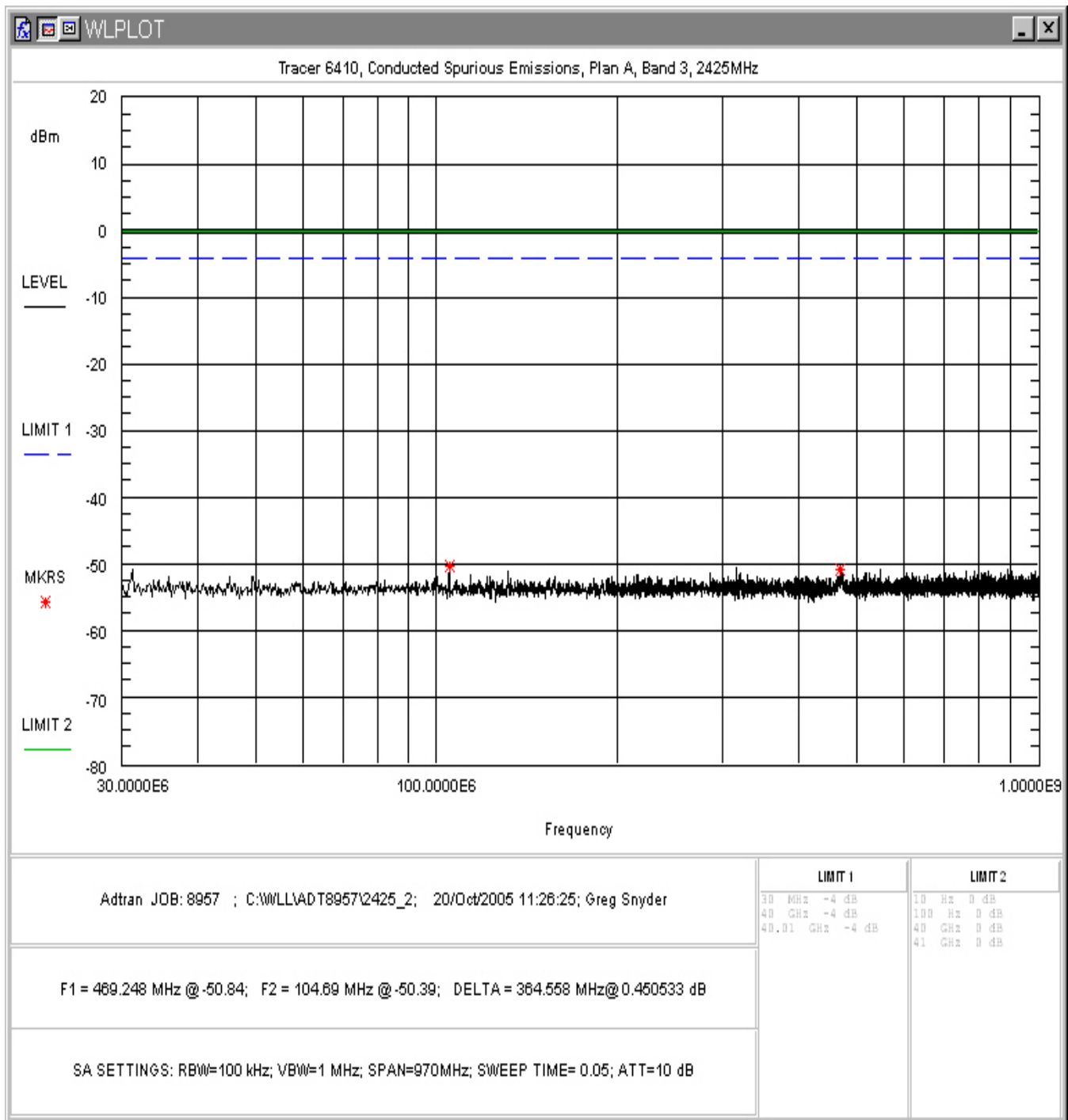

Figure 22. Conducted Spurious Emissions, Plan A Band 3, 30MHz - 1GHz

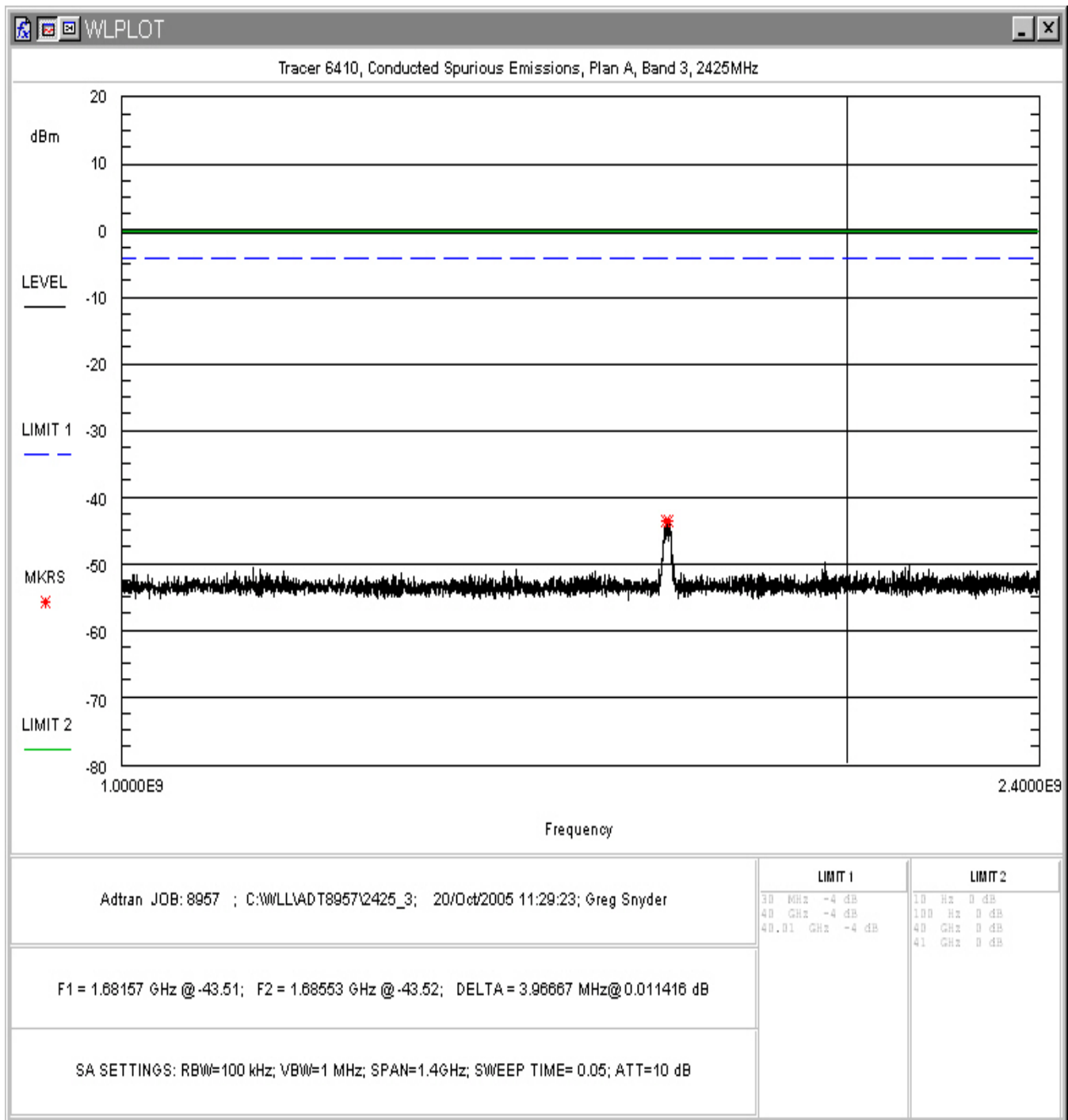

Figure 23. Conducted Spurious Emissions, Plan A Band 3, 1GHz – 2.4GHz

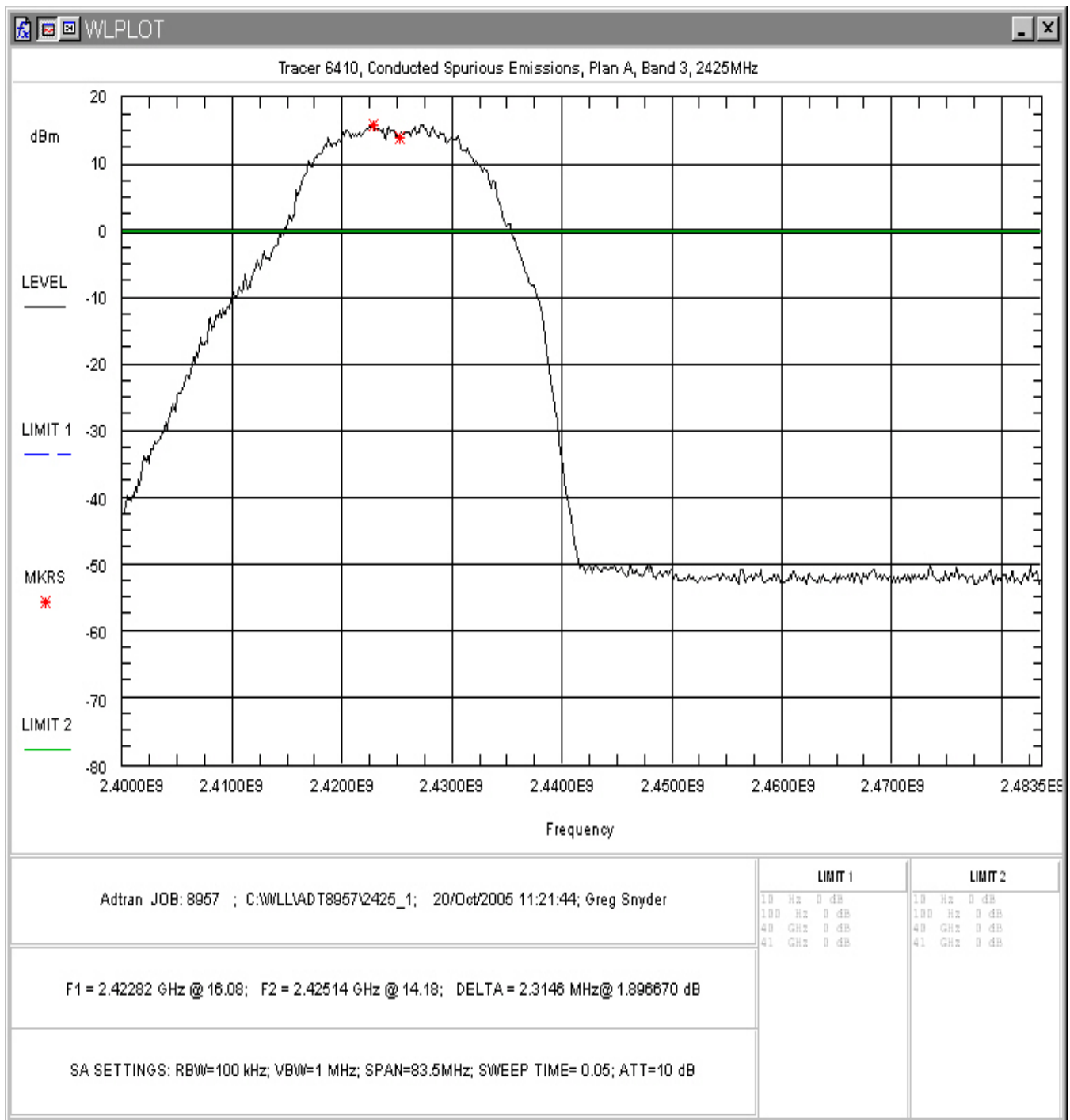

Figure 24. Conducted Spurious Emissions, Plan A Band 3, Inband

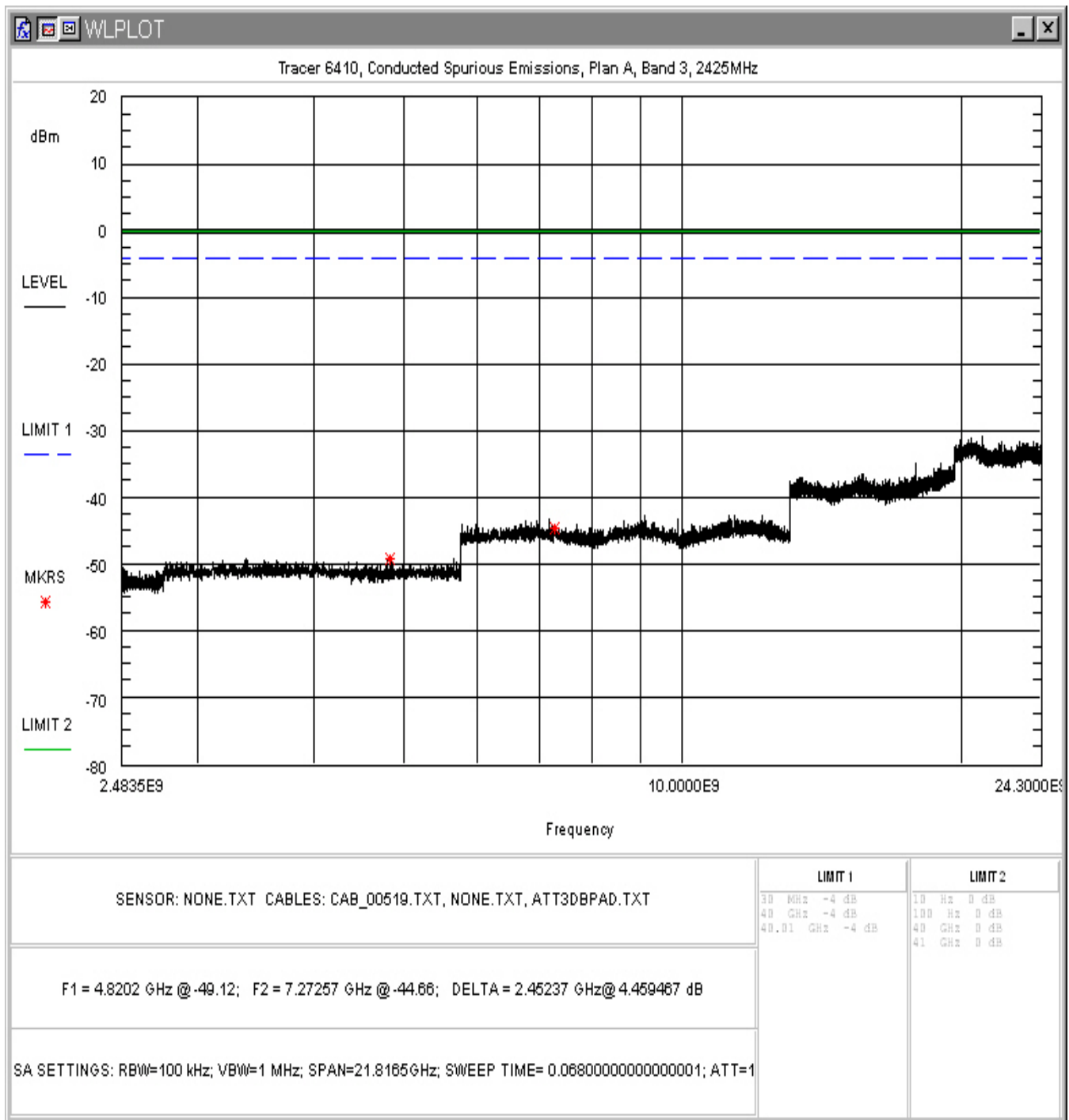

Figure 25. Conducted Spurious Emissions, Plan A Band 3, 2.4835 – 24.3GHz

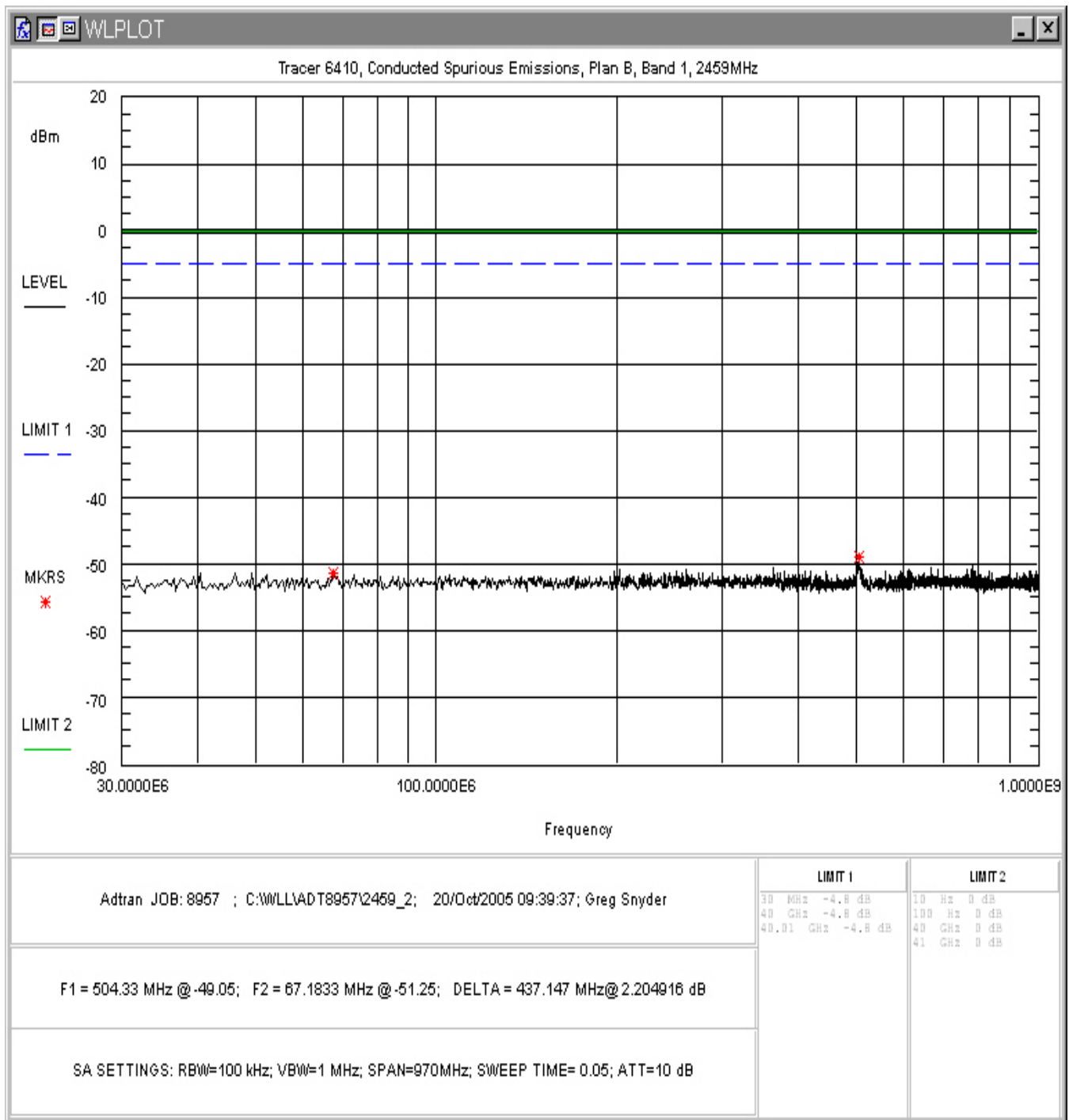

Figure 26. Conducted Spurious Emissions, Plan B Band 1, 30MHz - 1GHz

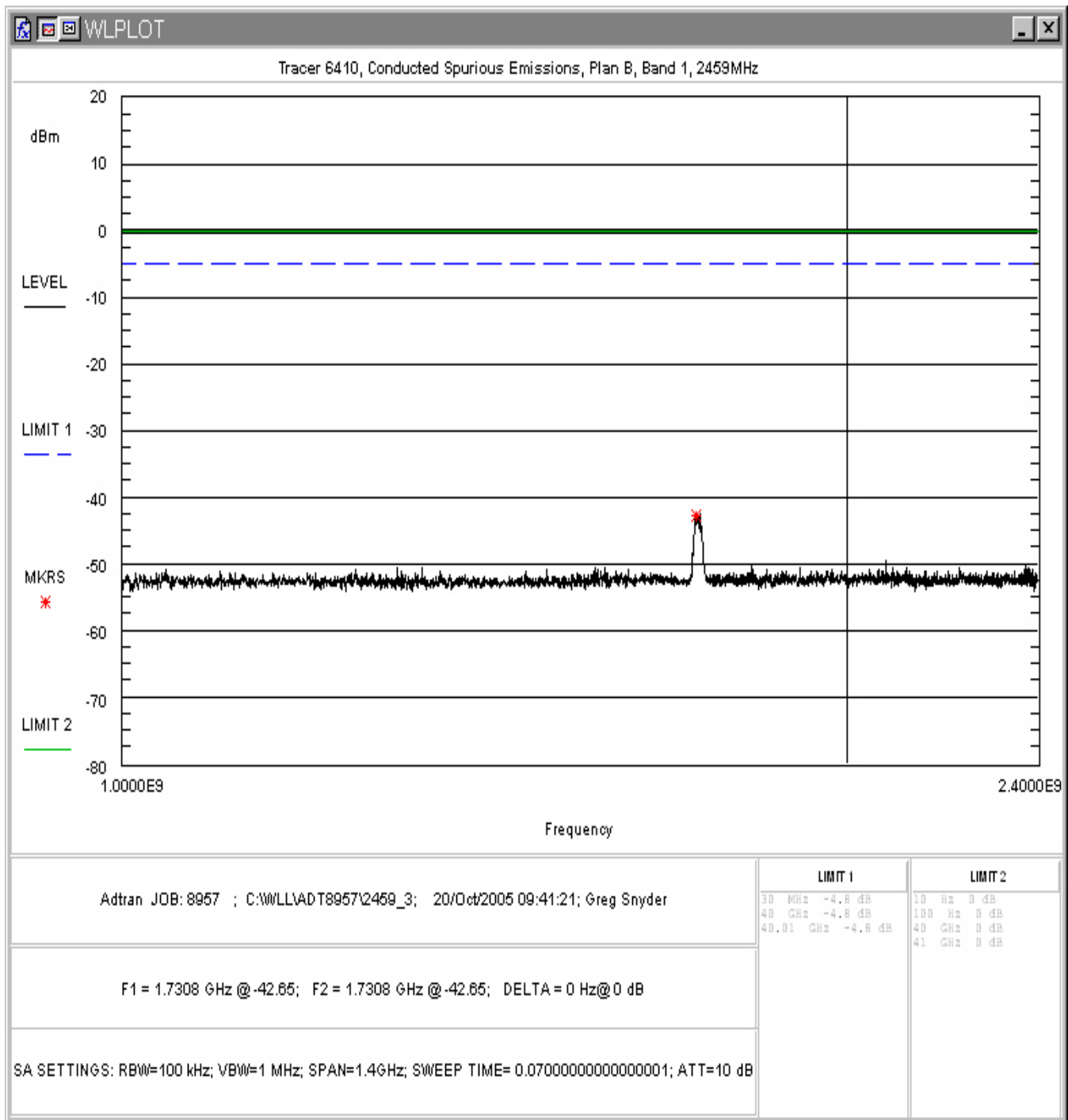

Figure 27. Conducted Spurious Emissions, Plan B Band 1, 1GHz – 2.4GHz

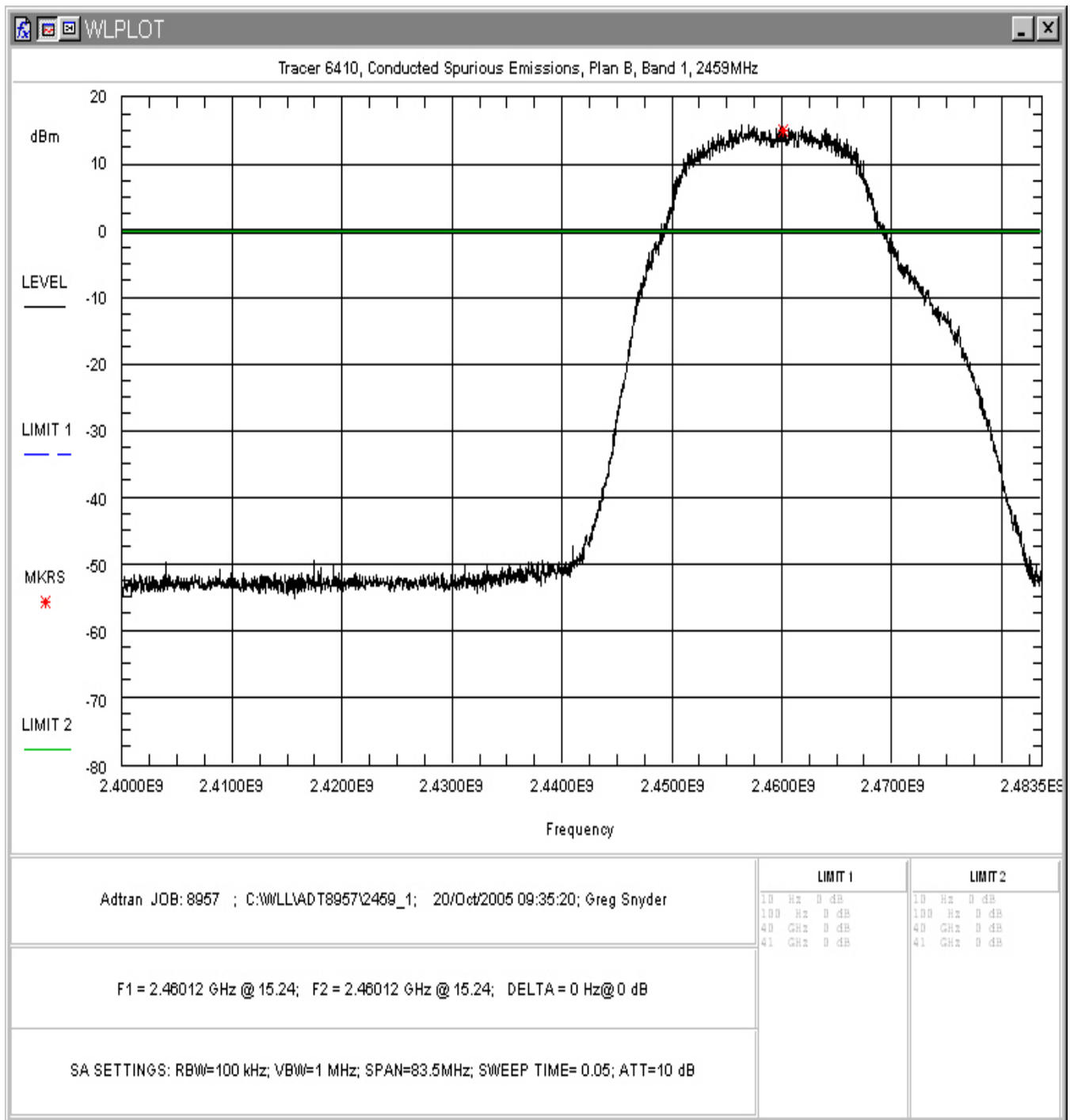

Figure 28. Conducted Spurious Emissions, Plan B Band 1, Inband

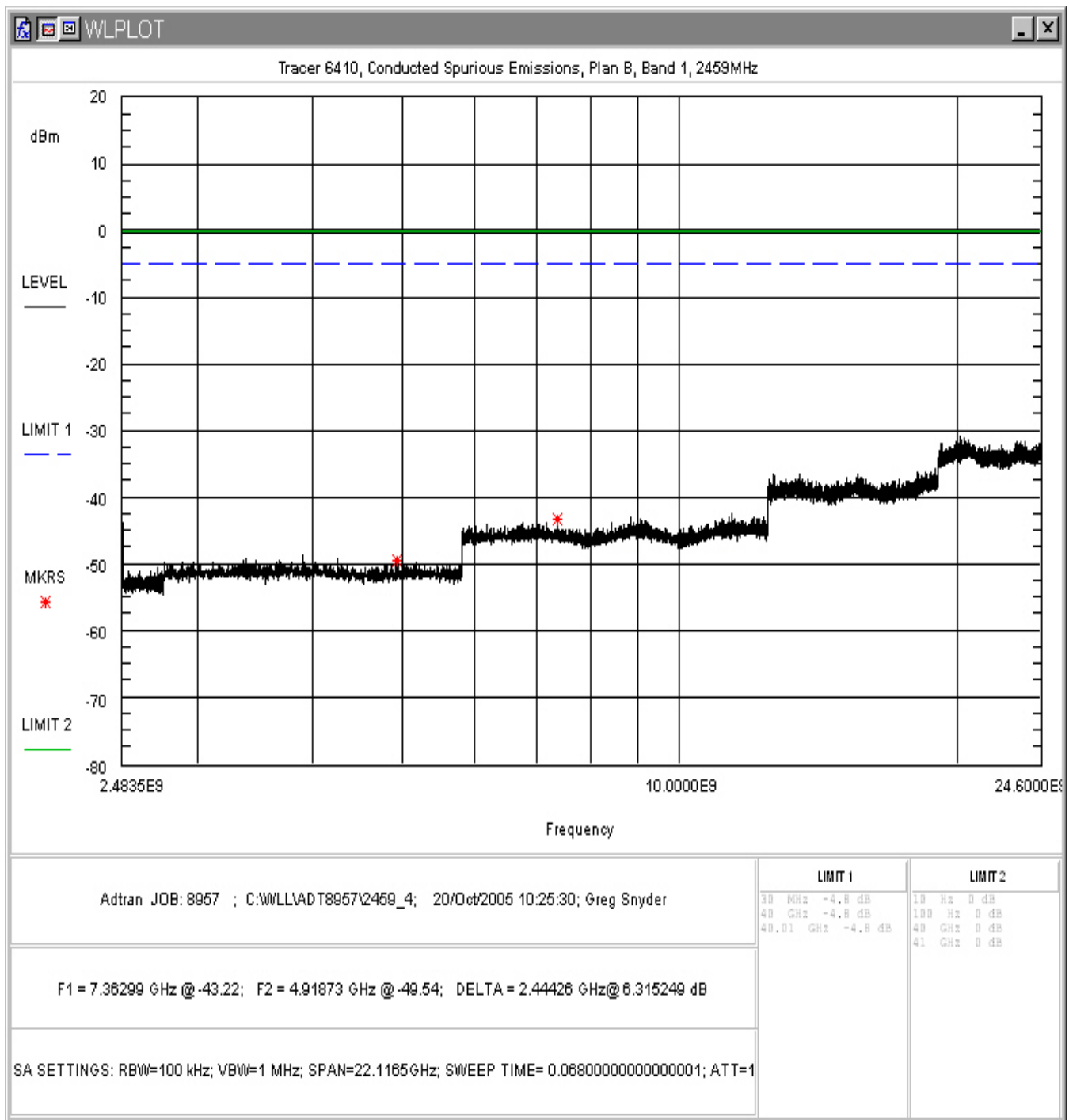

Figure 29. Conducted Spurious Emissions, Plan B Band 1, 2.4835 – 24.6GHz

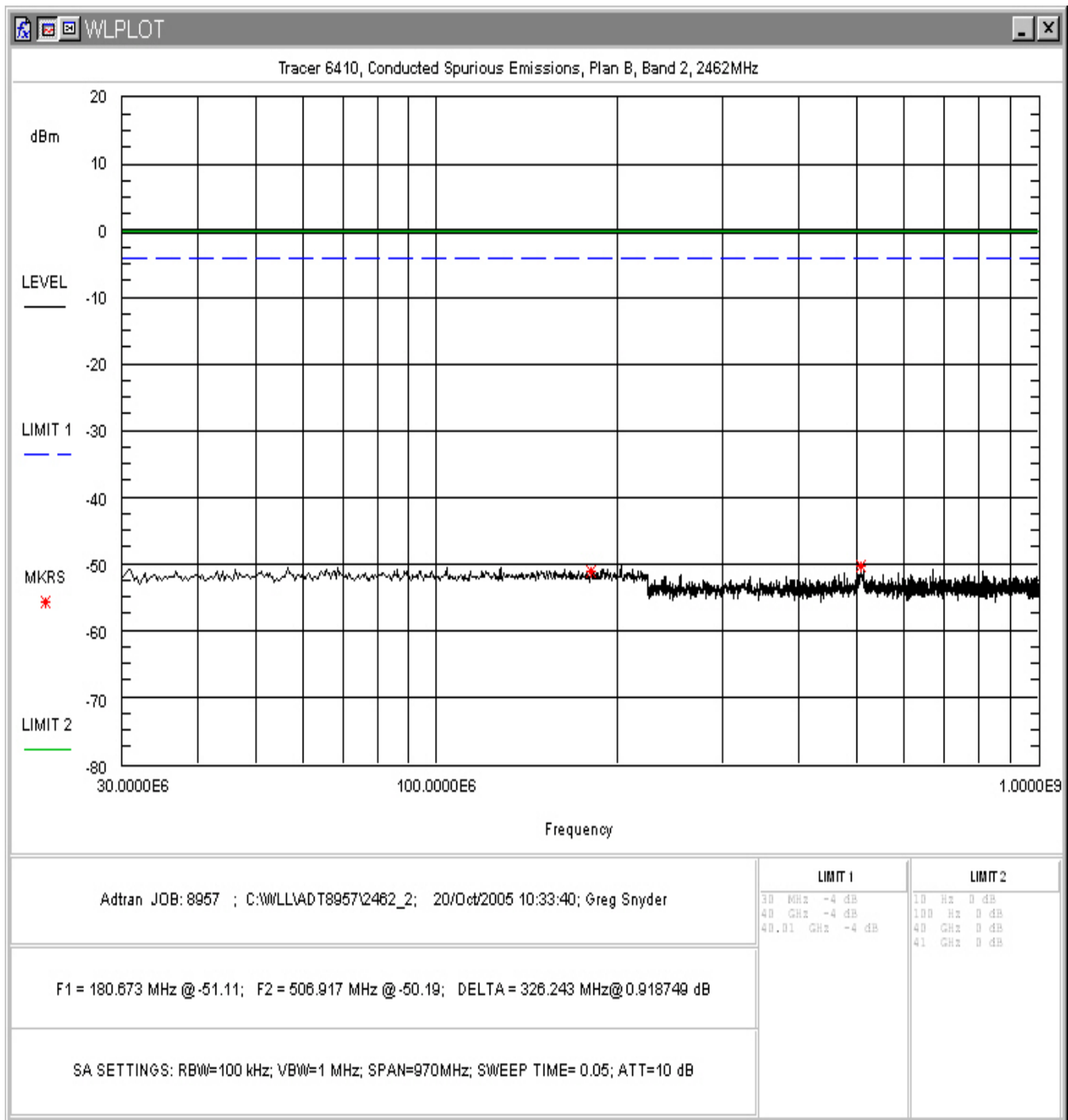

Figure 30. Conducted Spurious Emissions, Plan B Band 2, 30MHz - 1GHz

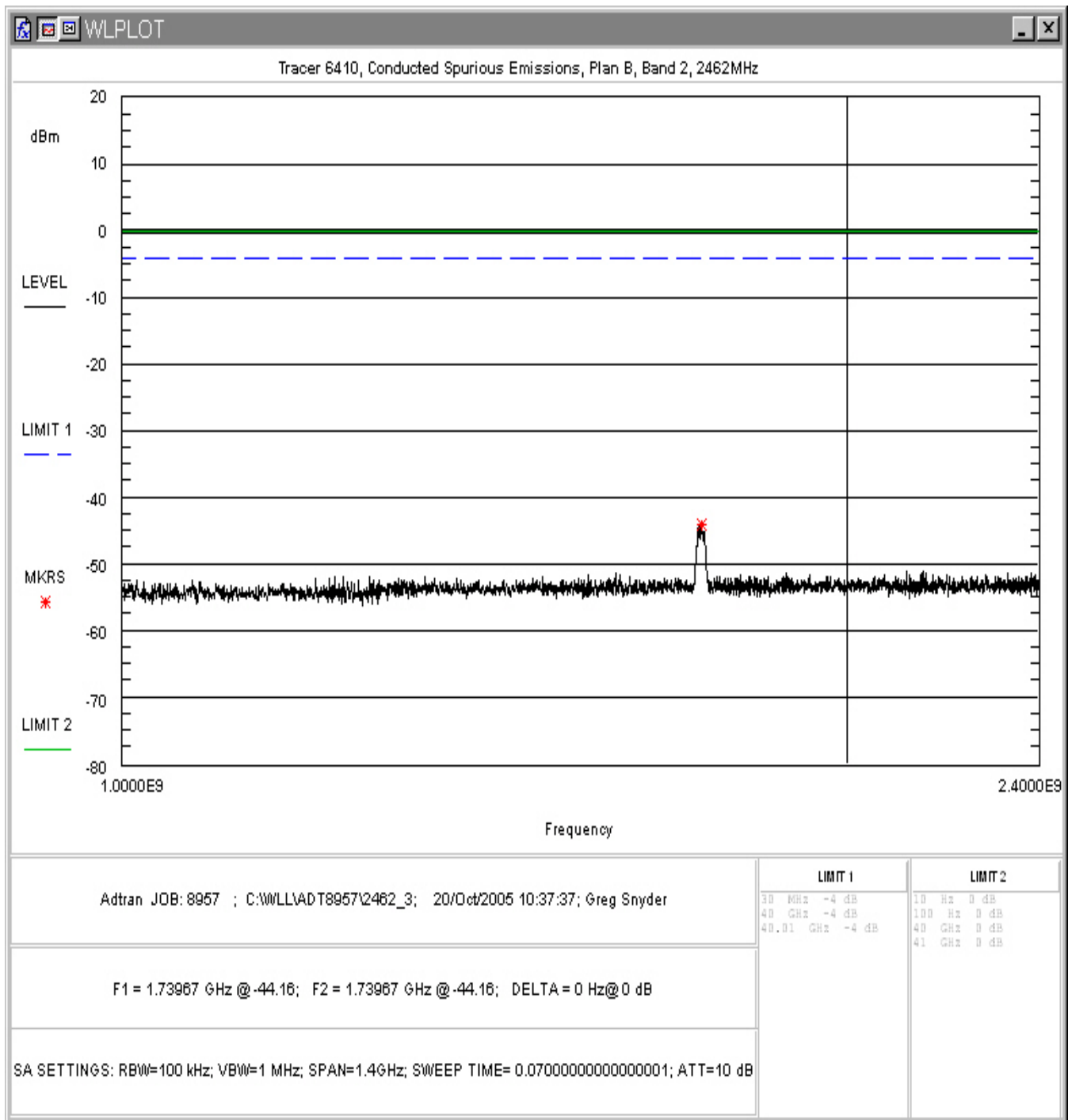

Figure 31. Conducted Spurious Emissions, Plan A Band 2, 1GHz – 2.4GHz

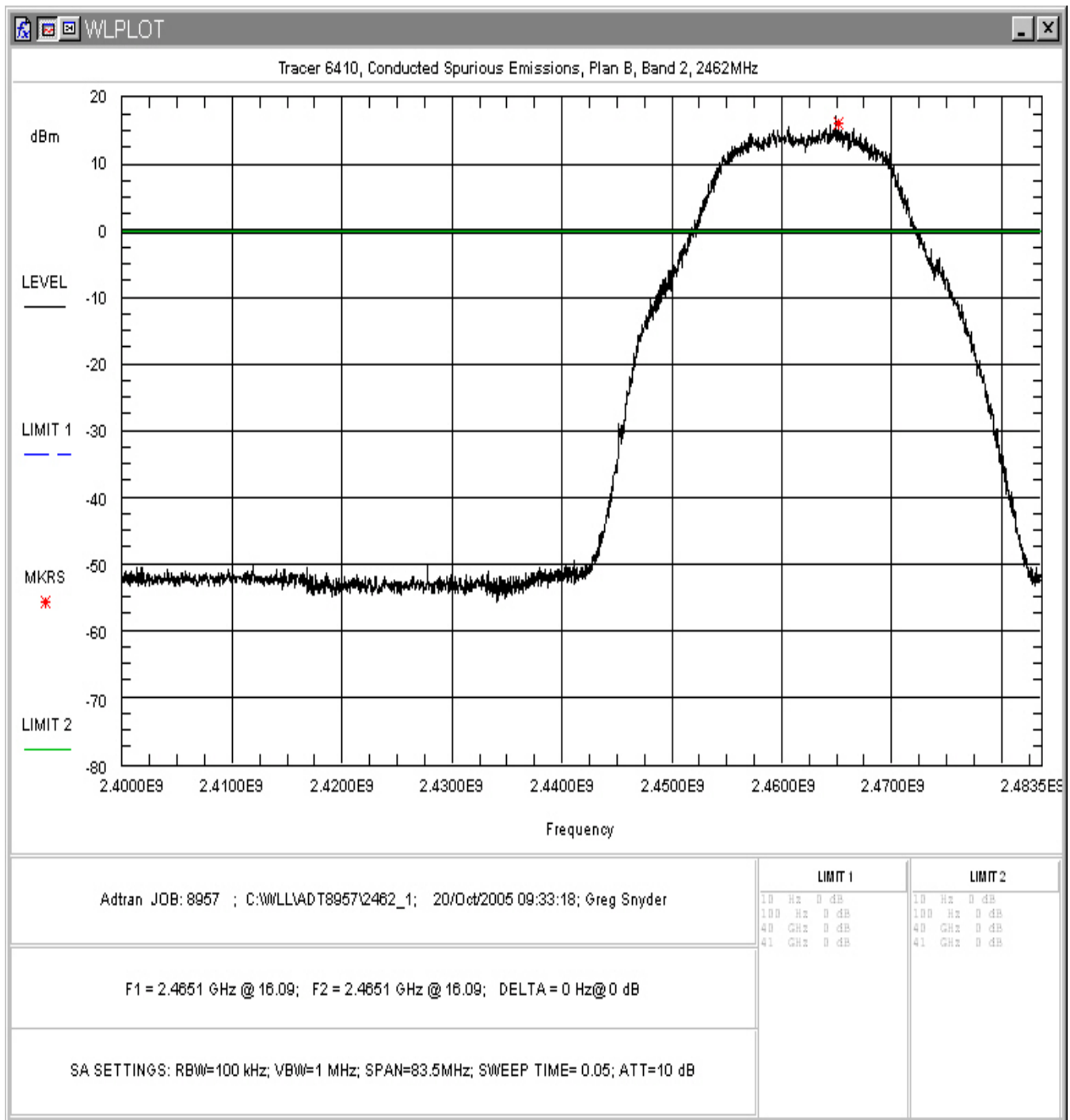

Figure 32. Conducted Spurious Emissions, Plan B Band 2, Inband

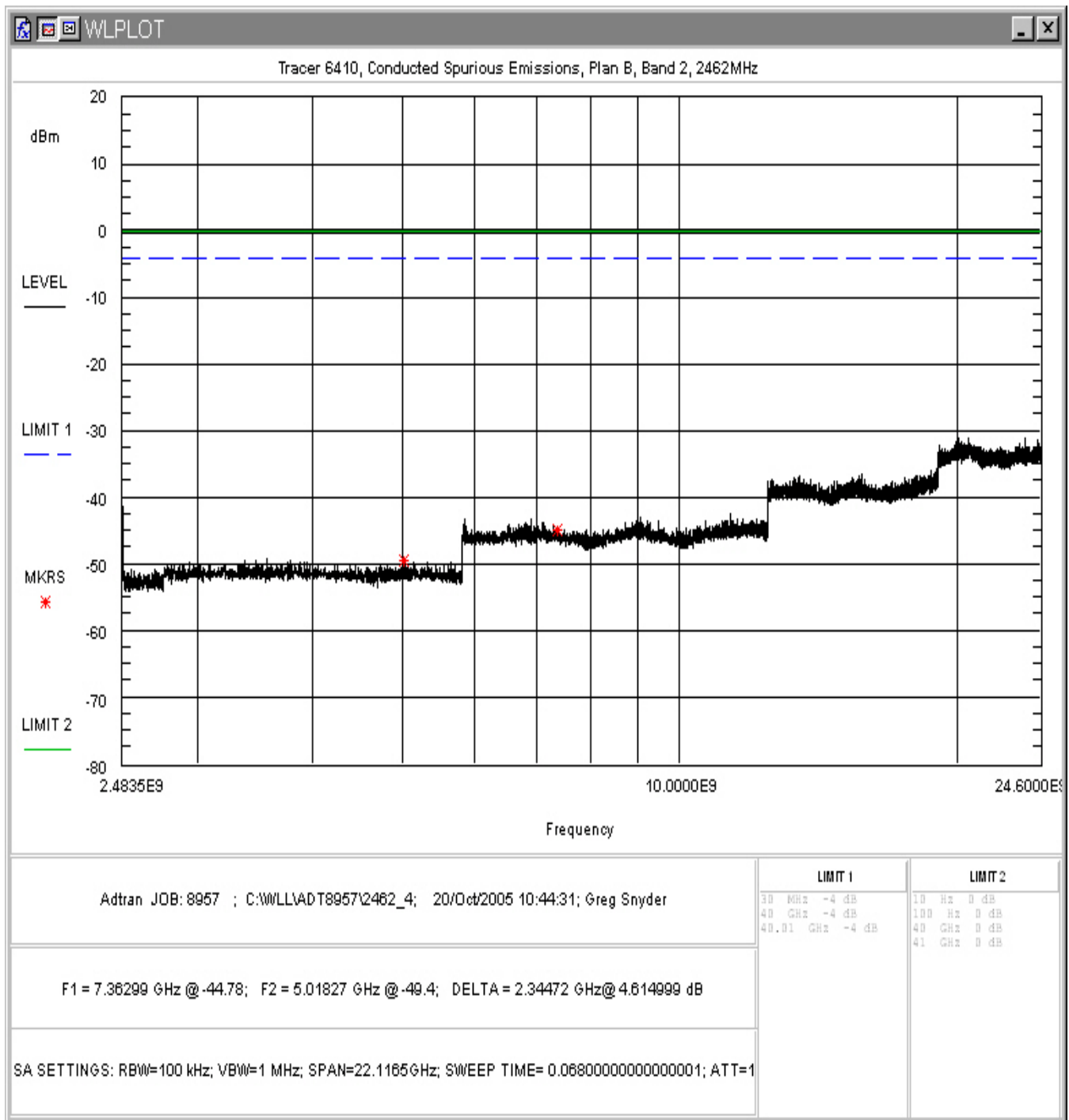

Figure 33. Conducted Spurious Emissions, Plan B Band 2, 2.4835 – 24.6GHz

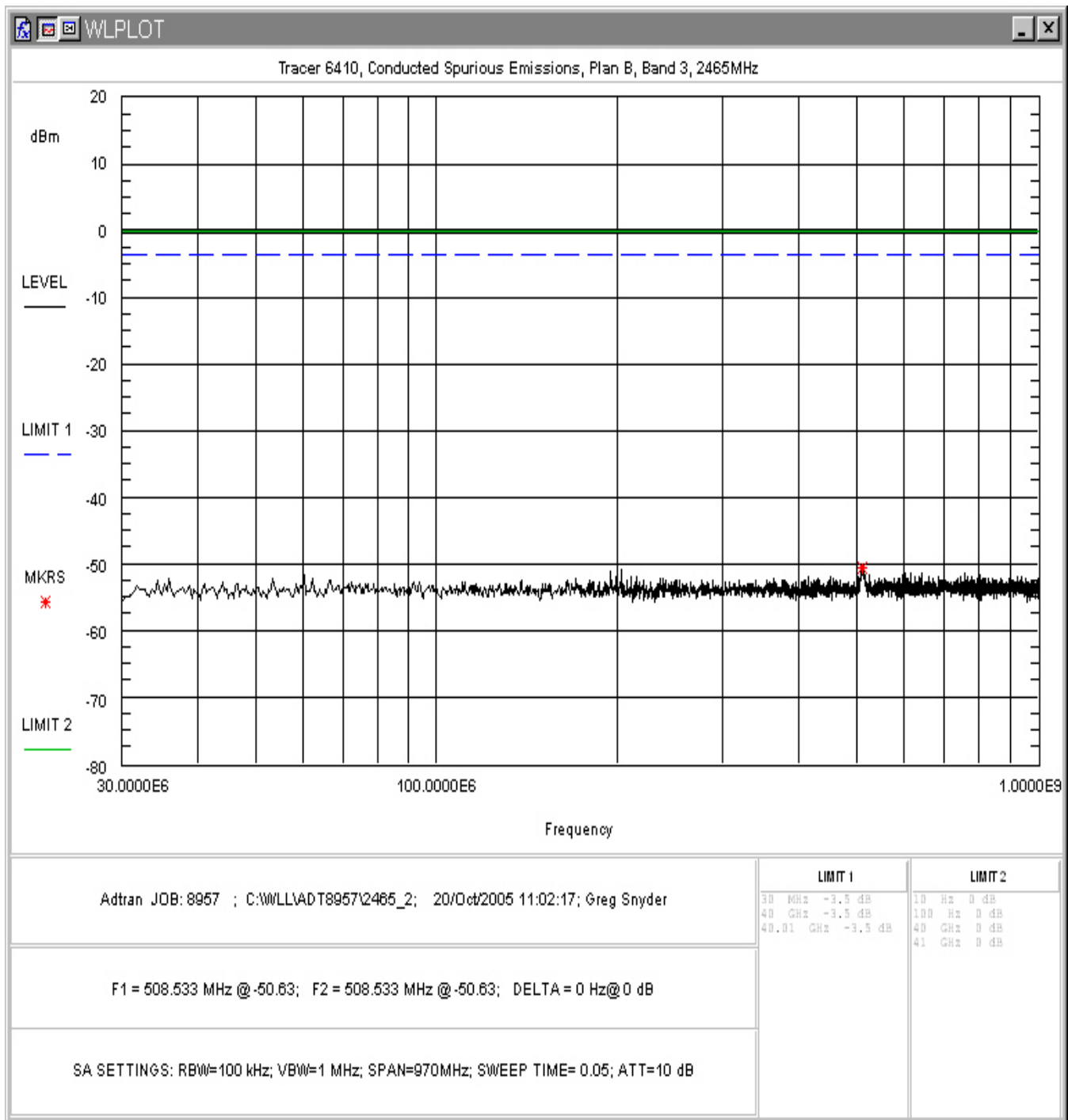

Figure 34. Conducted Spurious Emissions, Plan B Band 3, 30MHz - 1GHz

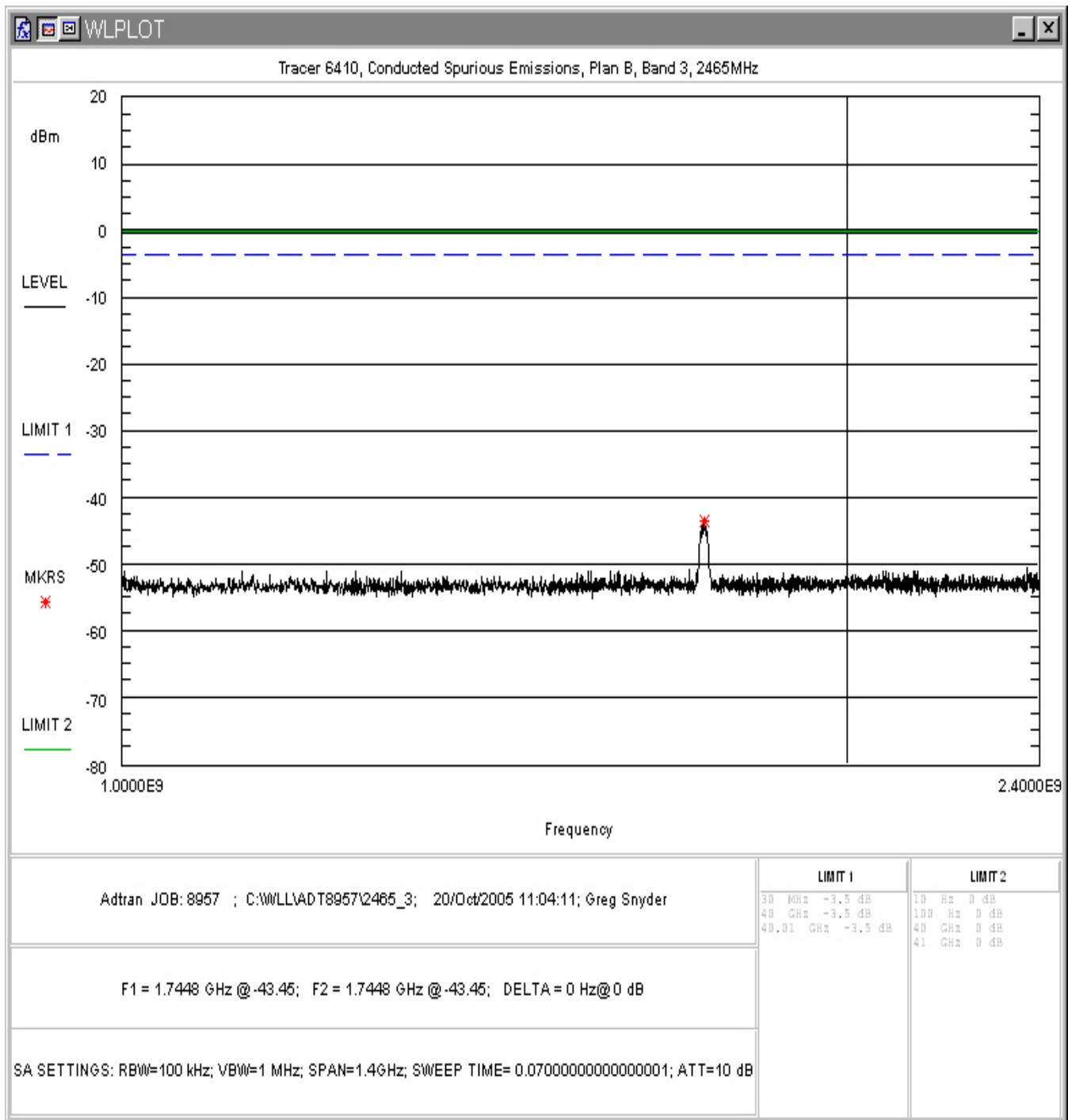

Figure 35. Conducted Spurious Emissions, Plan B Band 3, 1GHz – 2.4GHz

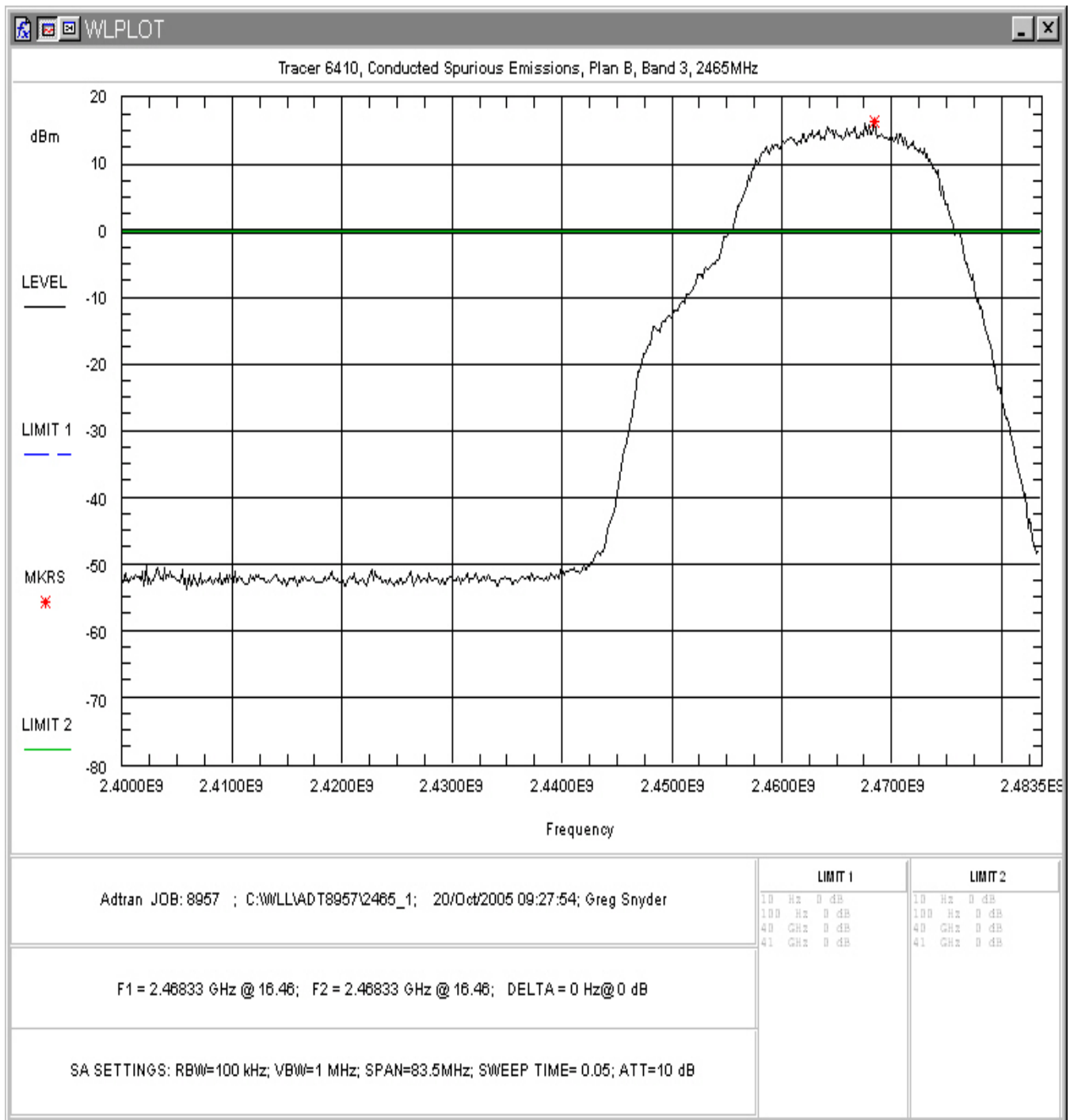

Figure 36. Conducted Spurious Emissions, Plan B Band 3, Inband

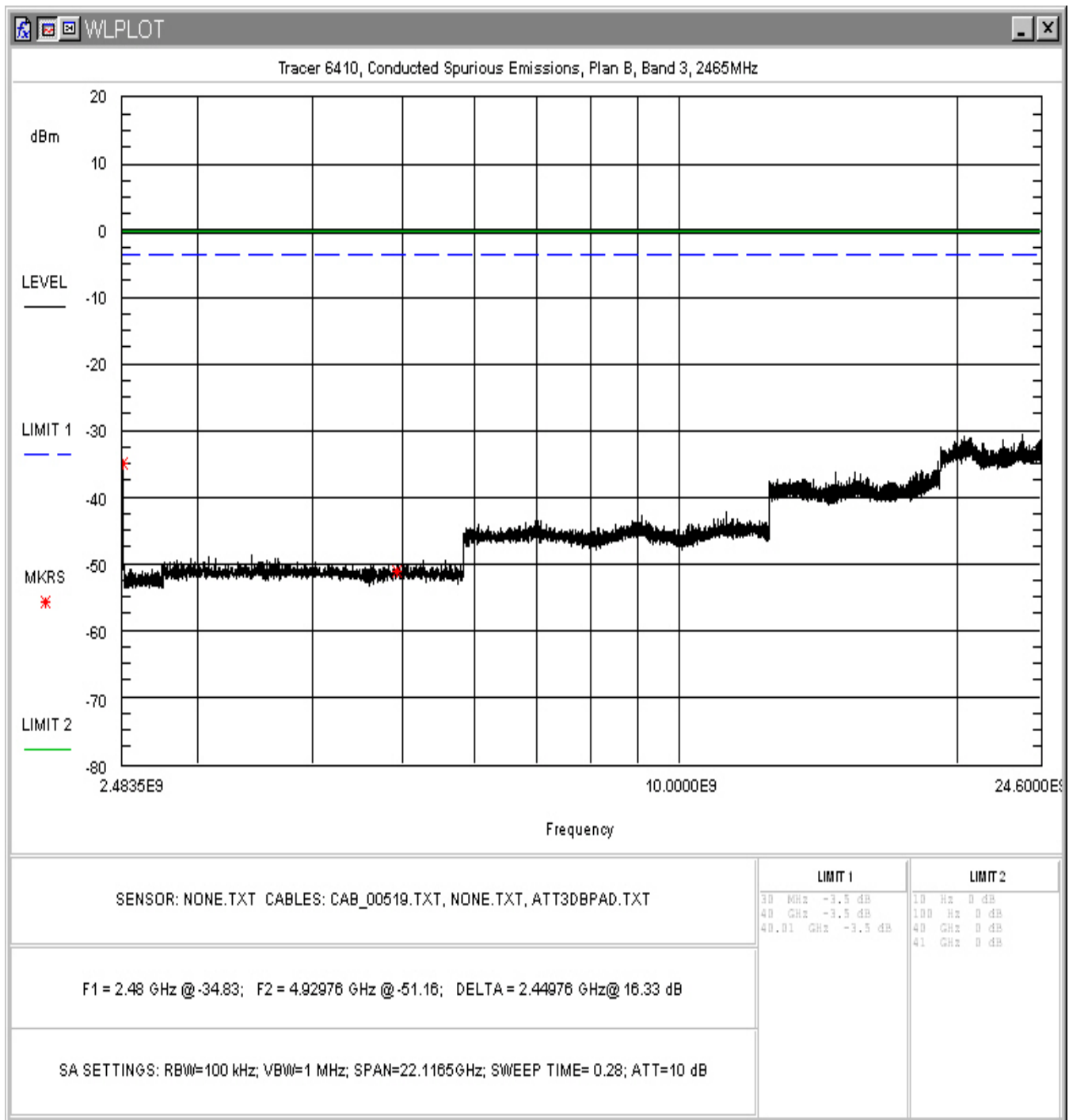

Figure 37. Conducted Spurious Emissions, Plan B Band 3, 2.4835 – 24.6GHz

4.5 Radiated Spurious Emissions: (FCC Part §15.247(c) and RSS-210 A8.5)

Radiated emissions that fall in the restricted bands must comply with the general emissions limits in 15.209(a) and RSS-210 Table 2.

The emissions were measured using the following resolution bandwidths:

Frequency Range	Resolution Bandwidth	Video Bandwidth
30MHz-1000 MHz	120kHz	>30 kHz
>1000 MHz	1 MHz	<30 Hz (Avg.) 1MHz (Peak)

Harmonic and Spurious emissions that were identified as coming from the EUT were checked in Peak and in Average Mode. It was verified that the peak-to-average ratio did not exceed 20dB.

Peak measurements and average measurements are made. All emissions were determined to have a peak-to-average ratio of less than 20 dB.

4.5.1 Test Procedure

The EUT was placed on motorized turntable for radiated testing on a 3-meter open field test site. The emissions from the EUT were measured continuously at every azimuth by rotating the turntable. Receiving antennas were mounted on an antenna mast to determine the height of maximum emissions. The height of the antenna was varied between 1 and 4 meters. The peripherals were placed on the table in accordance with ANSI C63.4-2003. Cables were varied in position to produce maximum emissions. Both the horizontal and vertical field components were measured.

The EUT was tested in the following configurations and modes:

Antenna	Channel
Dish	A&B

The following is a sample calculation used in the data tables for calculating the final field strength of spurious emissions and comparing these levels to the specified limits.

Sample Calculation:

Spectrum Analyzer Voltage (SA Level): V dBμV
 Antenna Factor (Ant Corr): AFdB/m
 Cable Loss Correction (Cable Corr): CCdB
 Amplifier Gain: GdB
 Electric Field (Corr Level): EdBμV/m = VdBμV + AFdB/m + CCdB - GdB
 To convert to linear units: EμV/m = antilog (EdBμV/m/20)

Data are supplied in the following tables. Testing was performed to 40GHz. No emissions were detected above 12GHz. All detected emissions are reported in the following tables. Both peak and

average measurements are listed. Following the transmit data are the data collected for the receiver spurious emissions.

Table 6: Radiated Emission Test Data, Low Frequency Data (<1GHz)

Frequency (MHz)	Pol H/V	Az Deg	Ant. Hght (m)	SA Level (dBµV)	Ant. Corr. (dB/m)	Cable Corr. (dB)	Corr. Level (dBµV/m)	Corr. Level (µV/m)	Limit (µV/m)	Margin dB
280.000	H	45.0	1.5	24.2	12.5	3.2	39.9	99.4	200.0	-6.1
440.000	H	180.0	1.5	18.5	15.3	4.1	37.9	78.3	200.0	-8.1
920.000	H	135.0	1.5	10.8	21.4	7.0	39.2	91.3	200.0	-6.8
280.000	V	0.0	1.5	18.2	12.5	3.2	33.9	49.8	200.0	-12.1
440.000	V	180.0	1.5	18.5	15.3	4.1	37.9	78.3	200.0	-8.1
520.000	V	270.0	1.5	19.7	16.6	4.7	41.0	111.8	200.0	-5.1
920.000	V	270.0	1.5	9.0	21.4	7.0	37.4	74.2	200.0	-8.6

Table 7: Radiated Emission Test Data, High Frequency Data: Plan A, Band 1 (2419MHz)

Frequency (MHz)	Pol H/V	Az Deg	Ant. Hght (m)	SA Level (dBµV)	Ant. Corr. (dB/m)	Cable Corr. (dB)	Amp Gain (dB)	Corr. Level (dBµV/m)	Corr. Level (µV/m)	Limit (µV/m)	Margin dB
				AVG.							
2390.000	H	0.0	1.0	53.7	28.9	2.9	35.5	50.0	314.8	500.0	-4.0
4278.000	H	190.0	1.0	38.2	31.6	3.9	35.5	38.2	81.4	500.0	-15.8
4838.000	H	180.0	1.0	34.8	32.5	4.1	35.9	35.5	59.6	500.0	-18.5
7257.000	H	0.0	1.0	34.0	37.1	5.0	35.7	40.4	104.2	500.0	-13.6
9676.000	H	0.0	1.0	34.3	38.6	5.7	36.3	42.3	130.5	500.0	-11.7
12095.000	H	0.0	1.0	34.5	40.0	6.6	35.6	45.5	188.2	500.0	-8.5
14514.000	H	0.0	1.0	36.8	41.3	7.5	34.6	51.0	353.7	500.0	-3.0
16933.000	H	0.0	1.0	34.3	42.3	8.0	34.9	49.7	306.9	500.0	-4.2
				PEAK							
2390.000	H	0.0	1.0	67.0	28.9	2.9	35.5	63.3	1455.8	5000.0	-10.7
4278.000	H	190.0	1.0	47.0	31.6	3.9	35.5	47.0	224.1	5000.0	-27.0
4838.000	H	180.0	1.0	45.0	32.5	4.1	35.9	45.7	193.0	5000.0	-28.3
7257.000	H	0.0	1.0	45.5	37.1	5.0	35.7	51.9	391.6	5000.0	-22.1
9676.000	H	0.0	1.0	44.5	38.6	5.7	36.3	52.5	422.3	5000.0	-21.5
12095.000	H	0.0	1.0	47.0	40.0	6.6	35.6	58.0	793.8	5000.0	-16.0
14514.000	H	0.0	1.0	47.6	41.3	7.5	34.6	61.8	1226.4	5000.0	-12.2
16933.000	H	0.0	1.0	44.7	42.3	8.0	34.9	60.1	1016.4	5000.0	-13.8
				AVG.							
1016.820	V	300.0	1.0	48.2	24.7	2.2	36.3	38.8	87.2	500.0	-15.2
2390.000	V	0.0	1.0	18.8	28.9	2.9	0.0	50.6	337.8	500.0	-3.4
4278.000	V	180.0	1.0	45.8	31.6	3.9	35.5	45.8	195.2	500.0	-8.2
4833.000	V	153.0	1.0	37.2	32.5	4.1	35.9	37.9	78.6	500.0	-16.1
7257.000	V	0.0	1.0	33.8	37.1	5.0	35.7	40.2	101.8	500.0	-13.8
9676.000	V	0.0	1.0	34.1	38.6	5.7	36.3	42.1	127.5	500.0	-11.9

12095.000	V	0.0	1.0	35.2	40.0	6.6	35.6	46.2	204.0	500.0	-7.8
14514.000	V	0.0	1.0	36.4	41.3	7.5	34.6	50.6	337.8	500.0	-3.4
16933.000	V	0.0	1.0	33.9	42.3	8.0	34.9	49.3	293.1	500.0	-4.6
				PEAK							
1016.820	V	300.0	1.0	62.2	24.7	2.2	36.3	52.8	437.0	5000.0	-21.2
2390.000	V	0.0	1.0	75.0	28.9	2.9	35.5	71.3	3656.8	5000.0	-2.7
4278.000	V	180.0	1.0	52.3	31.6	3.9	35.5	52.3	412.5	5000.0	-21.7
4833.000	V	153.0	1.0	50.5	32.5	4.1	35.9	51.2	363.3	5000.0	-22.8

Table 8: Radiated Emission Test Data, High Frequency Data: Plan A, Band 3 (2425MHz)

Frequency (MHz)	Pol H/V	Az Deg	Ant. Hght (m)	SA Level (dBµV)	Ant. Corr. (dB/m)	Cable Corr. (dB)	Amp Gain (dB)	Corr. Level (dBµV/m)	Corr. Level (µV/m)	Limit (µV/m)	Margin dB
				AVG							
4290.000	H	150.0	1.0	45.7	31.6	3.9	35.5	45.7	193.3	500.0	-8.3
4850.000	H	0.0	1.0	34.5	32.6	4.1	35.9	35.2	57.7	500.0	-18.8
7275.000	H	0.0	1.0	34.7	37.1	4.4	35.7	40.4	105.0	500.0	-13.6
9700.000	H	0.0	1.0	34.5	38.6	4.9	36.3	41.7	121.2	500.0	-12.3
12125.000	H	0.0	1.0	34.1	40.0	5.1	35.6	43.6	151.7	500.0	-10.4
14550.000	H	0.0	1.0	33.6	41.2	6.2	34.6	46.4	208.5	500.0	-7.6
16975.000	H	0.0	1.0	33.8	42.2	8.7	34.8	49.9	311.6	500.0	-4.1
				PEAK							
4290.000	H	150.0	1.0	51.2	31.6	3.9	35.5	51.2	364.1	5000.0	-22.8
4850.000	H	0.0	1.0	46.3	32.6	4.1	35.9	47.0	224.5	5000.0	-27.0
7275.000	H	0.0	1.0	47.5	37.1	4.4	35.7	53.2	458.2	5000.0	-20.8
9700.000	H	0.0	1.0	46.2	38.6	4.9	36.3	53.4	466.1	5000.0	-20.6
12125.000	H	0.0	1.0	45.2	40.0	5.1	35.6	54.7	544.5	5000.0	-19.3
14550.000	H	0.0	1.0	44.3	41.2	6.2	34.6	57.1	714.7	5000.0	-16.9
16975.000	H	0.0	1.0	46.3	42.2	8.7	34.8	62.4	1314.2	5000.0	-11.6
				AVG.							
1040.000	V	229.0	1.0	40.2	24.8	2.2	36.2	31.0	35.3	500.0	-23.0
4290.000	V	180.0	1.0	48.6	31.6	3.2	35.5	47.9	248.4	500.0	-6.1
4850.000	V	180.0	1.0	35.6	32.6	4.1	35.9	36.3	65.5	500.0	-17.7
7275.000	V	0.0	1.0	34.7	37.1	5.0	35.7	41.1	113.0	500.0	-12.9
9700.000	V	0.0	1.0	34.5	38.6	5.7	36.3	42.5	133.9	500.0	-11.4
12125.000	V	0.0	1.0	34.1	40.0	6.6	35.6	45.1	180.6	500.0	-8.8
14550.000	V	0.0	1.0	33.6	41.2	7.5	34.6	47.7	242.7	500.0	-6.3
16975.000	V	0.0	1.0	33.8	42.2	8.0	34.8	49.2	288.7	500.0	-4.8
				PEAK							
1040.000	V	229.0	1.0	51.3	24.8	2.2	36.2	42.1	126.7	5000.0	-31.9
4290.000	V	180.0	1.0	52.7	31.6	3.2	35.5	52.0	398.2	5000.0	-22.0
4850.000	V	180.0	1.0	49.0	32.6	4.1	35.9	49.7	306.4	5000.0	-24.3
7275.000	V	0.0	1.0	47.5	37.1	5.0	35.7	53.9	493.1	5000.0	-20.1
9700.000	V	0.0	1.0	46.2	38.6	5.7	36.3	54.2	515.0	5000.0	-19.7
12125.000	V	0.0	1.0	45.2	40.0	6.6	35.6	56.2	648.2	5000.0	-17.7
14550.000	V	0.0	1.0	44.3	41.2	7.5	34.6	58.4	831.9	5000.0	-15.6
16975.000	V	0.0	1.0	46.3	42.2	8.0	34.8	61.7	1217.5	5000.0	-12.3

Table 9: Radiated Emission Test Data, High Frequency Data: Plan B, Band 3 (2465MHz)

Frequency (MHz)	Pol H/V	Az Deg	Ant. Hght (m)	SA Level (dBµV)	Ant. Corr. (dB/m)	Cable Corr. (dB)	Amp Gain (dB)	Corr. Level (dBµV/m)	Corr. Level (µV/m)	Limit (µV/m)	Margin dB
				AVG.							
2483.500	H	0.0	1.0	54.8	29.1	1.5	35.6	49.9	311.0	500.0	-4.1
4296.000	H	150.0	1.0	41.8	31.6	3.2	35.5	41.1	113.7	500.0	-12.9
4930.000	H	180.0	1.0	36.0	32.7	3.6	36.0	36.3	65.3	500.0	-17.7
7395.000	H	0.0	1.0	34.4	37.1	4.7	35.8	40.4	105.0	500.0	-13.6
9860.000	H	0.0	1.0	34.5	38.8	4.9	36.4	41.8	122.9	500.0	-12.2
12325.000	H	0.0	1.0	35.6	40.0	5.3	35.4	45.5	187.7	500.0	-8.5
14790.000	H	0.0	1.0	36.5	40.9	6.3	34.8	48.8	275.7	500.0	-5.2
17255.000	H	0.0	1.0	32.8	42.9	9.5	34.8	50.4	330.5	500.0	-3.6
				PEAK							
2483.500	H	0.0	1.0	65.5	29.1	1.5	35.6	60.6	1065.9	5000.0	-13.4
4296.000	H	150.0	1.0	56.2	31.6	3.2	35.5	55.5	596.5	5000.0	-18.5
4930.000	H	180.0	1.0	47.8	32.7	3.6	36.0	48.1	254.1	5000.0	-25.9
7395.000	H	0.0	1.0	45.0	37.1	4.7	35.8	51.0	355.9	5000.0	-23.0
9860.000	H	0.0	1.0	44.1	38.8	4.9	36.4	51.4	371.2	5000.0	-22.6
12325.000	H	0.0	1.0	46.7	40.0	5.3	35.4	56.6	673.6	5000.0	-17.4
14790.000	H	0.0	1.0	47.8	40.9	6.3	34.8	60.1	1012.6	5000.0	-13.9
17255.000	H	0.0	1.0	45.2	42.9	9.5	34.8	62.8	1378.0	5000.0	-11.2
				AVG							
1040.000	V	229.0	1.0	39.4	24.8	1.2	36.2	29.2	28.7	500.0	-24.8
2483.500	V	0.0	1.0	56.2	29.1	1.5	35.6	51.3	365.4	500.0	-2.7
4296.000	V	180.0	1.0	40.6	31.6	3.2	35.5	39.9	99.0	500.0	-14.1
4930.000	V	180.0	1.0	36.8	32.7	3.6	36.0	37.1	71.6	500.0	-16.9
7395.000	V	0.0	1.0	33.5	37.1	4.7	35.8	39.5	94.7	500.0	-14.5
9860.000	V	0.0	1.0	34.5	38.8	4.9	36.4	41.8	122.9	500.0	-12.2
12325.000	V	0.0	1.0	35.6	40.0	5.3	35.4	45.5	187.7	500.0	-8.5
14790.000	V	0.0	1.0	36.5	40.9	6.3	34.8	48.8	275.7	500.0	-5.2
17255.000	V	0.0	1.0	32.8	42.9	9.5	34.8	50.4	330.5	500.0	-3.6
				PEAK							
1040.000	V	229.0	1.0	50.7	24.8	1.2	36.2	40.5	105.5	5000.0	-33.5
2483.500	V	0.0	1.0	69.7	29.1	1.5	35.6	64.8	1728.7	5000.0	-9.2
4296.000	V	180.0	1.0	52.4	31.6	3.2	35.5	51.7	385.1	5000.0	-22.3
4930.000	V	180.0	1.0	49.2	32.7	3.6	36.0	49.5	298.5	5000.0	-24.5
7395.000	V	0.0	1.0	45.0	37.1	4.7	35.8	51.0	355.9	5000.0	-23.0
9860.000	V	0.0	1.0	44.1	38.8	4.9	36.4	51.4	371.2	5000.0	-22.6
12325.000	V	0.0	1.0	46.7	40.0	5.3	35.4	56.6	673.6	5000.0	-17.4
14790.000	V	0.0	1.0	47.8	40.9	6.3	34.8	60.1	1012.6	5000.0	-13.9
17255.000	V	0.0	1.0	45.2	42.9	9.5	34.8	62.8	1378.0	5000.0	-11.2

Table 10, Receiver Spurious Radiated Emissions

Frequency (MHz)	Pol H/V	Az Deg	Ant. Hght (m)	SA Level (dBµV)	Ant. Corr. (dB/m)	Cable Corr. (dB)	Corr. Level (dBµV/m)	Corr. Level (µV/m)	Limit (µV/m)	Margin dB
30.900	H	180.0	4.0	8.2	16.9	1.3	26.4	20.9	100.0	-13.6
44.760	H	270.0	2.5	12.2	15.2	1.5	29.0	28.1	100.0	-11.0
63.470	H	270.0	4.0	21.7	8.9	1.8	32.3	41.3	100.0	-7.7
64.840	H	270.0	4.0	18.7	8.4	1.8	28.8	27.6	100.0	-11.2
75.780	H	90.0	4.0	23.0	6.1	1.9	31.0	35.5	100.0	-9.0
79.860	H	270.0	4.0	26.0	6.3	1.9	34.2	51.3	100.0	-5.8
83.950	H	112.5	4.0	22.0	7.1	1.9	31.0	35.6	100.0	-9.0
92.150	H	180.0	4.0	22.8	8.4	2.0	33.2	45.5	150.0	-10.4
108.530	H	112.5	2.0	22.7	9.9	2.2	34.7	54.4	150.0	-8.8
120.830	H	270.0	3.0	16.5	10.8	2.2	29.6	30.1	150.0	-13.9
135.870	H	180.0	3.0	18.2	9.1	2.4	29.6	30.2	150.0	-13.9
161.000	H	270.0	3.0	12.8	9.0	2.5	24.3	16.3	150.0	-19.3
225.000	H	180.0	2.0	12.6	11.4	2.9	26.9	22.2	200.0	-19.1
235.500	H	45.0	2.0	12.5	11.7	3.0	27.2	22.9	200.0	-18.8
240.000	H	270.0	2.0	16.2	11.7	3.0	30.9	35.1	200.0	-15.1
256.000	H	270.0	2.0	11.8	11.8	3.1	26.7	21.6	200.0	-19.3
270.000	H	270.0	2.0	12.0	13.3	3.2	28.5	26.6	200.0	-17.5
338.500	H	45.0	1.5	23.8	13.9	3.6	41.3	115.7	200.0	-4.8
749.240	H	90.0	1.5	10.5	19.8	6.0	36.2	64.9	200.0	-9.8
62.865	V	180.0	1.0	16.9	9.1	1.8	27.7	24.4	100.0	-12.3
75.780	V	0.0	1.0	14.0	6.1	1.9	22.0	12.6	100.0	-18.0
83.950	V	90.0	1.0	18.4	7.1	1.9	27.4	23.5	100.0	-12.6
108.530	V	45.0	1.0	20.9	9.9	2.2	32.9	44.2	150.0	-10.6
135.870	V	180.0	1.0	18.0	9.1	2.4	29.4	29.6	150.0	-14.1
165.875	V	270.0	1.0	11.5	9.6	2.5	23.6	15.1	150.0	-19.9
204.760	V	270.0	1.0	5.6	9.8	2.8	18.2	8.1	150.0	-25.3
225.000	V	0.0	1.0	8.5	11.4	2.9	22.8	13.8	200.0	-23.2
338.500	V	270.0	1.5	22.6	13.9	3.6	40.1	100.7	200.0	-6.0
600.000	V	180.0	1.5	20.3	17.5	5.5	43.3	146.6	200.0	-2.7
749.240	V	212.5	1.5	10.8	19.8	6.0	36.5	67.2	200.0	-9.5

>1GHz

Frequency (MHz)	Pol H/V	Az Deg	Ant. Hght (m)	SA Level (dBµV)	Ant. Corr. (dB/m)	Cable Corr. (dB)	Amp Gain (dB)	Corr. Level (dBµV/m)	Corr. Level (µV/m)	Limit (µV/m)	Margin dB
1000.000	H	132.0	1.2	54.5	24.6	2.2	36.3	45.0	177.8	500.0	-9.0
1017.330	H	114.0	1.0	38.8	24.7	2.2	36.3	29.4	29.6	500.0	-24.6
1000.000	V	147.0	1.0	53.5	24.6	2.2	36.3	44.0	158.5	500.0	-10.0
1017.330	V	305.0	1.0	38.3	24.7	2.2	36.3	28.9	27.9	500.0	-25.1

4.6 AC Powerline Conducted Emissions: (FCC Part §15.207 and RSS-GEN)

The EUT was placed on an 80 cm high 1 x 1.5 m non-conductive table above a ground plane. Power to the EUT was provided through a Solar Corporation 50 Ω/50 μH Line Impedance Stabilization Network bonded to a 3 x 2 meter ground plane. The LISN has its AC input supplied from a filtered AC power source. Power and data cables were moved about to obtain maximum emissions.

The 50Ω output of the LISN was connected to the input of the spectrum analyzer and the emissions in the frequency range of 150 kHz to 30 MHz were measured. The detector function was set to quasi-peak, peak, or average as appropriate, and the resolution bandwidth during testing was at least 9 kHz, with all post-detector filtering no less than 10 times the resolution bandwidth for peak measurements.

Data is recorded in the following table.

Table 11: Conducted Emissions Test Data; §15.207

LINE 1 - NEUTRAL										
Frequency	Level	Cable	Limit	Level	Margin	Level	Cable	Level	Limit	Margin
MHz	QP	Loss	QP	Corr	QP	AVG	Loss	Corr	AVG	AVG
	dBuV	dB	dBuV	dBuV	dB	dBuV	dB	dBuV	dBuV	dB
0.305	32.8	10.2	60.1	43.0	-17.1	32.7	10.2	42.9	50.1	-7.2
0.481	31.0	10.3	56.3	41.3	-15.0	30.0	10.3	40.3	46.3	-6.0
0.654	31.3	10.4	56.0	41.7	-14.3	29.7	10.4	40.1	46.0	-5.9
0.829	30.9	10.5	56.0	41.4	-14.6	29.7	10.5	40.2	46.0	-5.8
1.240	31.5	10.5	56.0	42.0	-14.0	30.9	10.5	41.4	46.0	-4.6
2.140	29.6	10.5	56.0	40.1	-15.9	27.9	10.5	38.4	46.0	-7.6
6.945	28.5	11.2	60.0	39.7	-20.3	28.5	11.2	39.7	50.0	-10.3
10.040	33.8	11.6	60.0	45.4	-14.6	31.2	11.6	42.8	50.0	-7.2
LINE 2 - PHASE										
Frequency	Level	Cable	Limit	Level	Margin	Level	Cable	Level	Limit	Margin
MHz	QP	Loss	QP	Corr	QP	AVG	Loss	Corr	AVG	AVG
	dBuV	dB	dBuV	dBuV	dB	dBuV	dB	dBuV	dBuV	dB
0.309	33.4	10.2	60.0	43.6	-16.4	32.1	10.2	42.3	50.0	-7.7
0.484	31.3	10.3	56.3	41.6	-14.7	30.6	10.3	40.9	46.3	-5.4
0.657	31.2	10.4	56.0	41.6	-14.4	30.3	10.4	40.7	46.0	-5.3
0.831	30.9	10.5	56.0	41.4	-14.6	30.1	10.5	40.6	46.0	-5.4
1.056	30.9	10.5	56.0	41.4	-14.6	29.5	10.5	40.0	46.0	-6.0
2.316	30.0	10.5	56.0	40.5	-15.5	28.1	10.5	38.6	46.0	-7.4
6.945	29.3	11.2	60.0	40.5	-19.5	29.3	11.2	40.5	50.0	-9.5
10.040	35.0	11.6	60.0	46.6	-13.4	31.7	11.6	43.3	50.0	-6.7