



FCC RF Test Report

APPLICANT : Adtran
EQUIPMENT : BSAP-2020,DUAL RADIO
BRAND NAME : Adtran
MODEL NAME : BSAP-2020,DUAL RADIO
FCC ID : HDCBSAP2020
STANDARD : FCC Part 15 Subpart E §15.407
CLASSIFICATION : (NII) Unlicensed National Information Infrastructure

The product was received on Jan. 23, 2016 and testing was completed on Feb. 03, 2016. We, SPORTON INTERNATIONAL INC., would like to declare that the tested sample has been evaluated in accordance with the test procedures and has been in compliance with the applicable technical standards.

The test results in this report apply exclusively to the tested model / sample. Without written approval of SPORTON INTERNATIONAL INC., the test report shall not be reproduced except in full.

Reviewed by: Joseph Lin / Supervisor

Approved by: Jones Tsai / Manager



Testing Laboratory
1190

SPORTON INTERNATIONAL INC.

No. 52, Hwa Ya 1st Rd., Hwa Ya Technology Park, Kwei-Shan District, Tao Yuan City, Taiwan, R.O.C.



TABLE OF CONTENTS

REVISION HISTORY.....3

SUMMARY OF TEST RESULT4

1 GENERAL DESCRIPTION5

1.1 Applicant5

1.2 Manufacturer5

1.3 Product Feature of Equipment Under Test.....5

1.4 Product Specification of Equipment Under Test.....6

1.5 Modification of EUT6

1.6 Testing Location7

1.7 Applicable Standards.....7

2 TEST CONFIGURATION OF EQUIPMENT UNDER TEST8

2.1 Carrier Frequency and Channel8

2.2 Pre-Scanned RF Power9

2.3 Test Mode.....10

2.4 Connection Diagram of Test System11

2.5 Support Unit used in test configuration and system12

2.6 EUT Operation Test Setup12

2.7 Measurement Results Explanation Example.....12

3 TEST RESULT13

3.1 6dB and 26dB and 99% Occupied Bandwidth Measurement13

3.2 Maximum Conducted Output Power Measurement16

3.3 Power Spectral Density Measurement17

3.4 Unwanted Emissions Measurement20

3.5 AC Conducted Emission Measurement.....26

3.6 Frequency Stability Measurement36

3.7 Automatically Discontinue Transmission37

3.8 Antenna Requirements38

4 LIST OF MEASURING EQUIPMENT39

5 UNCERTAINTY OF EVALUATION41

APPENDIX A. CONDUCTED TEST RESULTS

APPENDIX B. RADIATED TEST RESULTS

APPENDIX C. RADIATED SPURIOUS EMISSION PLOTS

APPENDIX D. SETUP PHOTOGRAPHS



REVISION HISTORY

REPORT NO.	VERSION	DESCRIPTION	ISSUED DATE
FR5D2212-02C	Rev. 01	Initial issue of report	Feb. 16, 2016



SUMMARY OF TEST RESULT

Report Section	FCC Rule	Description	Limit	Result	Remark
3.1	15.403(i)	6dB, 26dB and 99% Occupied Bandwidth	> 500kHz	Pass	-
3.2	15.407(a)	Maximum Conducted Output Power	≤ 30 dBm	Pass	-
3.3	15.407(a)	Power Spectral Density	≤ 30 dBm/500kHz	Pass	-
3.4	15.407(b)	Unwanted Emissions	≤ -17, -27 dBm/MHz & 15.209(a)	Pass	Under limit 0.45 dB at 11650.000 MHz
3.5	15.207	AC Conducted Emission	15.207(a)	Pass	Under limit 4.80 dB at 0.366 MHz
3.6	15.407(g)	Frequency Stability	Within Operation Band	Pass	-
3.7	15.407(c)	Automatically Discontinue Transmission	Discontinue Transmission	Pass	-
3.8	15.203 & 15.407(a)	Antenna Requirement	N/A	Pass	-



1 General Description

1.1 Applicant

Adtran

901 Explorer Boulevard Huntsville, AL 35806-2807 United States

1.2 Manufacturer

Senao Networks, Inc.

3F, No. 529, Chung Cheng Rd., Hsintien, Taipei, Taiwan, R.O.C

1.3 Product Feature of Equipment Under Test

Product Feature	
Equipment	BSAP-2020,DUAL RADIO
Brand Name	Adtran
Model Name	BSAP-2020,DUAL RADIO
FCC ID	HDCBSAP2020
EUT supports Radios application	WLAN 11a/b/g/n HT20/HT40 WLAN 11ac VHT20/VHT40/VHT80
EUT Stage	Production Unit

Remark: The above EUT's information was declared by manufacturer. Please refer to the specifications or user's manual for more detailed description.



1.4 Product Specification of Equipment Under Test

Standards-related Product Specification							
Tx/Rx Channel Frequency Range	5745 MHz ~ 5825 MHz						
Maximum Output Power	MIMO <Ant. 1 + 2> 802.11a : 22.19 dBm / 0.1656 W 802.11n HT20 : 23.25 dBm / 0.2113 W 802.11n HT40 : 23.45 dBm / 0.2213 W 802.11ac VHT20: 23.30 dBm / 0.2138 W 802.11ac VHT40: 23.58 dBm / 0.2280 W 802.11ac VHT80: 14.05 dBm / 0.0254 W						
99% Occupied Bandwidth	802.11a : 17.55 MHz 802.11n HT20 : 18.80 MHz 802.11n HT40 : 36.90 MHz 802.11ac VHT20 : 18.95 MHz 802.11ac VHT40 : 36.80 MHz 802.11ac VHT80 : 75.96 MHz						
Type of Modulation	802.11a/n : OFDM (BPSK / QPSK / 16QAM / 64QAM) 802.11ac : OFDM (BPSK / QPSK / 16QAM / 64QAM / 256QAM)						
Antenna Type	Ant. 1 : PIFA Antenna Ant. 2 : PIFA Antenna						
Antenna Gain	Ant. 1 : 5.23 dBi Ant. 2 : 5.68 dBi						
Antenna Function Description	<table border="1"> <thead> <tr> <th></th> <th>Ant. 1</th> <th>Ant. 2</th> </tr> </thead> <tbody> <tr> <td>802.11 a/n/ac MIMO</td> <td>V</td> <td>V</td> </tr> </tbody> </table>		Ant. 1	Ant. 2	802.11 a/n/ac MIMO	V	V
	Ant. 1	Ant. 2					
802.11 a/n/ac MIMO	V	V					

1.5 Modification of EUT

No modifications are made to the EUT during all test items.



1.6 Testing Location

Sporton Lab is accredited to ISO 17025 by Taiwan Accreditation Foundation (TAF code : 1190) and the FCC designation No. TW1022 under the FCC 2.948(e) by Mutual Recognition Agreement (MRA) in FCC Test.

Test Site	SPORTON INTERNATIONAL INC.	
Test Site Location	No. 52, Hwa Ya 1 st Rd., Hwa Ya Technology Park, Kwei-Shan District, Tao Yuan City, Taiwan, R.O.C. TEL: +886-3-327-3456 FAX: +886-3-328-4978	
Test Site No.	Sporton Site No.	
	TH02-HY	CO05-HY

Note: The test site complies with ANSI C63.4 2014 requirement.

Test Site	SPORTON INTERNATIONAL INC.	
Test Site Location	No.58, Aly. 75, Ln. 564, Wenhua 3rd Rd. Guishan Dist, Taoyuan City, Taiwan (R.O.C.) TEL: +886-3-327-0868 FAX: +886-3-327-0855	
Test Site No.	Sporton Site No.	
	03CH12-HY	

Note: The test site complies with ANSI C63.4 2014 requirement.

1.7 Applicable Standards

According to the specifications of the manufacturer, the EUT must comply with the requirements of the following standards:

- ♦ FCC Part 15 Subpart E
- ♦ FCC KDB 789033 D02 General UNII Test Procedures New Rules v01r01
- ♦ FCC KDB 662911 D01 Multiple Transmitter Output v02r01.
- ♦ ANSI C63.10-2013

Remark: All test items were verified and recorded according to the standards and without any deviation during the test.



2 Test Configuration of Equipment Under Test

The EUT has been associated with peripherals and configuration operated in a manner tended to maximize its emission characteristics in a typical application. Frequency range investigated: conducted emission (150 kHz to 30 MHz) and radiated emission (9 kHz to the 10th harmonic of the highest fundamental frequency or to 40 GHz, whichever is lower). For radiated measurement, pre-scanned in three orthogonal panels, X, Y, Z. The worst cases (Y plane) were recorded in this report.

The final configuration from all the combinations and the worst-case data rates were investigated by measuring the maximum power across all the data rates and modulation modes under section 2.2.

Based on the worst configuration found above, the RF power setting is set individually to meet FCC compliance limit for the final conducted and radiated tests shown in section 2.3.

2.1 Carrier Frequency and Channel

Frequency Band	Channel	Freq. (MHz)	Channel	Freq. (MHz)
5725-5850 MHz Band 4 (U-NII-3)	149	5745	157	5785
	151	5755	159	5795
	153	5765	161	5805
	155	5775	165	5825

Note: The above Frequency and Channel in boldface were 802.11n HT40.



2.2 Pre-Scanned RF Power

Preliminary tests were performed in different data rate and data rate associated with the highest power were chosen for full test in the following tables.

MIMO <Ant. 1+2>

5GHz 802.11a mode								
Data Rate (MHz)	6M bps	9M bps	12M bps	18M bps	24M bps	36M bps	48M bps	54M bps
Average Power (dBm)	22.19	21.83	22.00	22.03	22.18	21.57	21.83	21.73

5GHz 802.11n HT20 mode								
Data Rate (MHz)	MCS0	MCS1	MCS2	MCS3	MCS4	MCS5	MCS6	MCS7
Average Power (dBm)	23.25	22.86	23.00	23.04	22.96	22.62	22.77	22.71

5GHz 802.11n HT40 mode								
Data Rate (MHz)	MCS0	MCS1	MCS2	MCS3	MCS4	MCS5	MCS6	MCS7
Average Power (dBm)	23.45	23.27	23.23	23.28	23.09	22.88	22.84	22.87

5GHz 802.11ac VHT20 mode									
Data Rate (MHz)	MCS 0	MCS 1	MCS 2	MCS 3	MCS 4	MCS 5	MCS 6	MCS 7	MCS 8
Average Power (dBm)	23.30	22.92	22.77	22.98	22.86	22.84	22.80	22.88	22.80

5GHz 802.11ac VHT40 mode										
Data Rate (MHz)	MCS 0	MCS 1	MCS 2	MCS 3	MCS 4	MCS 5	MCS 6	MCS 7	MCS 8	MCS 9
Average Power (dBm)	23.58	23.40	23.56	23.52	23.57	23.54	23.01	23.22	23.13	23.11

5GHz 802.11ac VHT80 mode										
Data Rate (MHz)	MCS 0	MCS 1	MCS 2	MCS 3	MCS 4	MCS 5	MCS 6	MCS 7	MCS 8	MCS 9
Average Power (dBm)	14.05	13.98	13.93	13.83	13.92	13.93	13.86	13.96	13.91	13.92

Note: MIMO Ant. 1+2 is a calculated result from sum of the power MIMO Ant. 1 and MIMO Ant. 2.



2.3 Test Mode

Final test mode of conducted test items and radiated spurious emissions are considering the modulation and worse data rates from the power table described in section 2.2.

MIMO Antenna

Modulation	Data Rate
802.11a	6 Mbps
802.11n HT20	MCS0
802.11n HT40	MCS0
802.11ac VHT20	MCS0
802.11ac VHT40	MCS0
802.11ac VHT80	MCS0

AC Conducted	Mode 1 : 5G Tx + RJ-45 Link + Adapter
Emission	Mode 2 : 5G Tx + RJ-45 Link + PoE
Remark: The worst case of conducted emission is mode1; only the test data of it was reported.	

Ch. #		Band IV : 5725-5850 MHz		
		802.11a	802.11n HT20	802.11n HT40
L	Low	149	149	151
M	Middle	157	157	-
H	High	165	165	159

Ch. #		Band IV : 5725-5850 MHz		
		802.11ac VHT20	802.11ac VHT40	802.11ac VHT80
L	Low	149	151	-
M	Middle	157	-	155
H	High	165	159	-

2.4 Connection Diagram of Test System

<EUT with Adapter Mode>

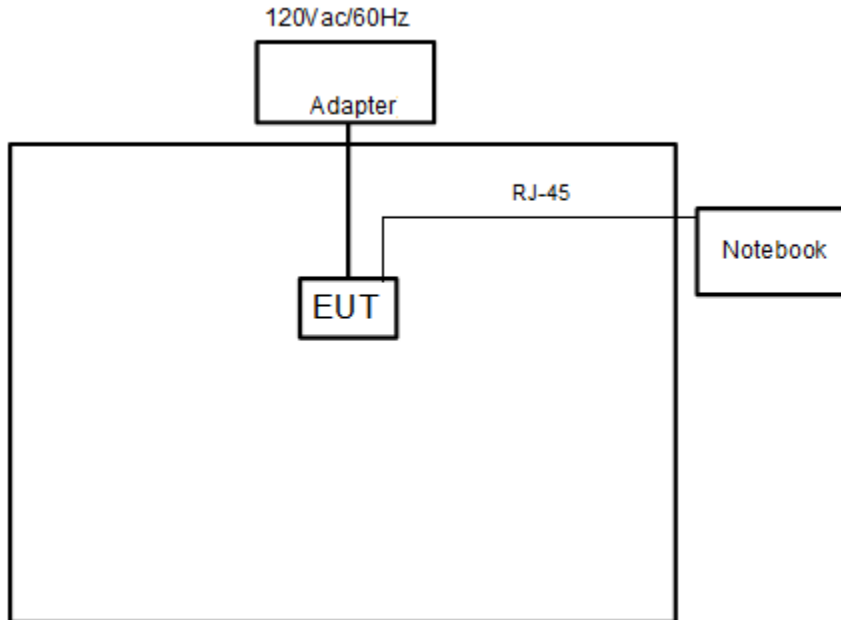

<EUT with POE Mode>

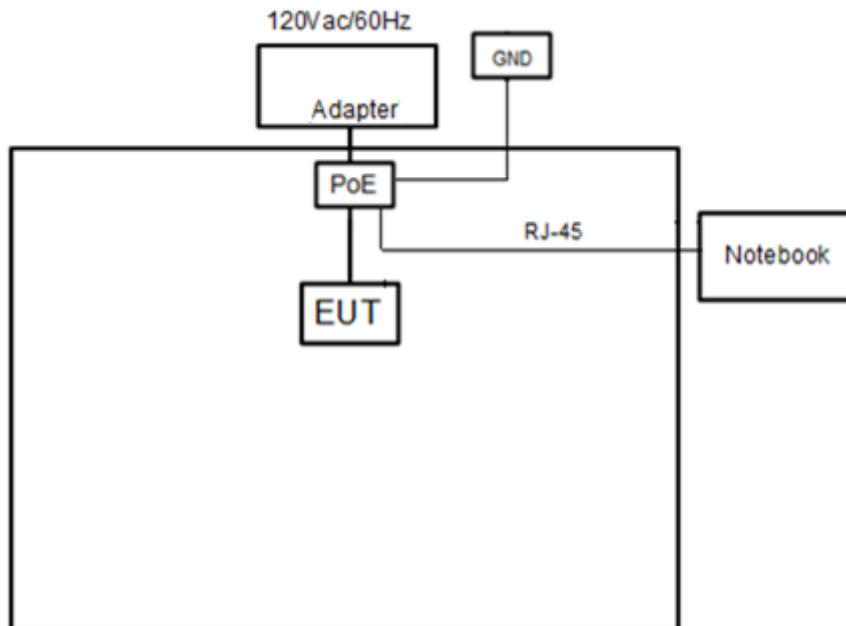



2.5 Support Unit used in test configuration and system

Item	Equipment	Trade Name	Model Name	FCC ID	Data Cable	Power Cord
1.	Notebook	DELL	Latitude E6320	FCC DoC/ Contains FCC ID: QDS-BRCM1054	N/A	AC I/P: Unshielded, 1.2 m DC O/P: Shielded, 1.8 m
2.	Notebook	Lenovo	M490S	FCC DoC	N/A	AC I/P: Unshielded, 1.2 m DC O/P: Shielded, 1.8 m
3.	POE Adapter	Powertron Electronics Corp	PA1040-480IB080	N/A	N/A	1.5m
4.	POE	N/A	NPE-5818	N/A	N/A	N/A
5.	Adapter	Powertron Electronics Corp.	PA1015-2I/PA1015-2I PA1015-2I120125	N/A	N/A	1.2m

2.6 EUT Operation Test Setup

For WLAN function, programmed RF utility, "Art2-gui Tool" installed in the notebook make the EUT provide functions like channel selection and power level for continuous transmitting and receiving signals.

N AP under large package sizes transmission.

2.7 Measurement Results Explanation Example

For all conducted test items:

The offset level is set in the spectrum analyzer to compensate the RF cable loss and attenuator factor between EUT conducted output port and spectrum analyzer. With the offset compensation, the spectrum analyzer reading level is exactly the EUT RF output level.

Example :

The spectrum analyzer offset is derived from RF cable loss and attenuator factor.

Offset = RF cable loss + attenuator factor.

Following shows an offset computation example with cable loss 4.2 dB and 10dB attenuator.

$$\begin{aligned}
\text{Offset(dB)} &= \text{RF cable loss(dB)} + \text{attenuator factor(dB)}. \\
&= 4.2 + 10 = 14.2 \text{ (dB)}
\end{aligned}$$

3 Test Result

3.1 6dB and 26dB and 99% Occupied Bandwidth Measurement

3.1.1 Description of 6dB and 26dB and 99% Occupied Bandwidth

The minimum 6 dB bandwidth shall be at least 500 kHz.

26dB and 99% Occupied bandwidth are reporting only.

3.1.2 Measuring Instruments

The measuring equipment is listed in the section 4 of this test report.

3.1.3 Test Procedures

1. The testing follows FCC KDB 789033 D02 General UNII Test Procedures New Rules v01r01.
Section C) Emission bandwidth for the band 5.725-5.85GHz
2. Set RBW = 100kHz.
3. Set the VBW $\geq 3 \times$ RBW.
4. Detector = Peak.
5. Trace mode = max hold
6. Measure the maximum width of the emission that is 6 dB down from the peak of the emission.
7. Measure and record the results in the test report.

3.1.4 Test Setup





3.1.5 Test Result of 6dB Bandwidth

Please refer to Appendix A.

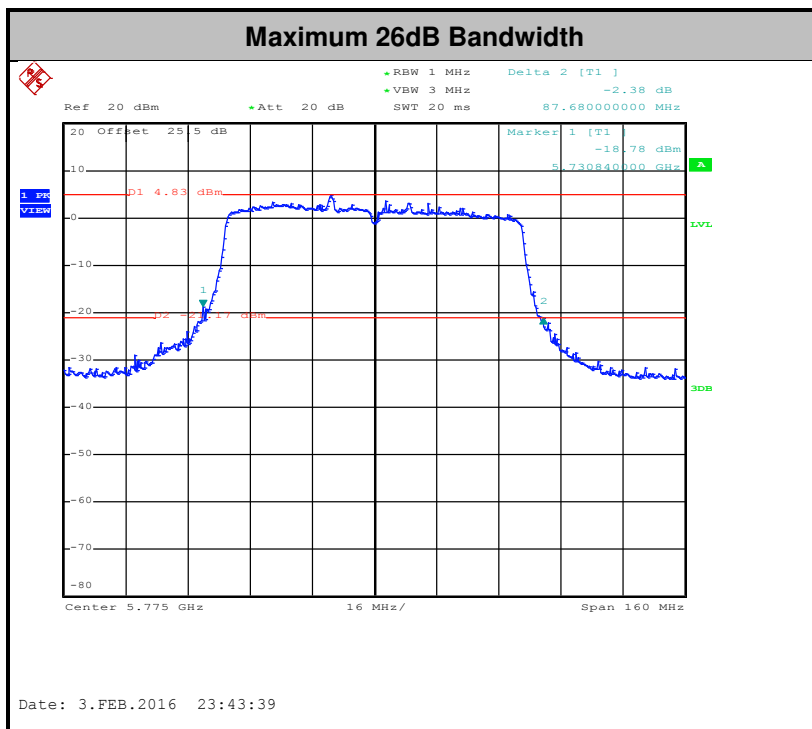
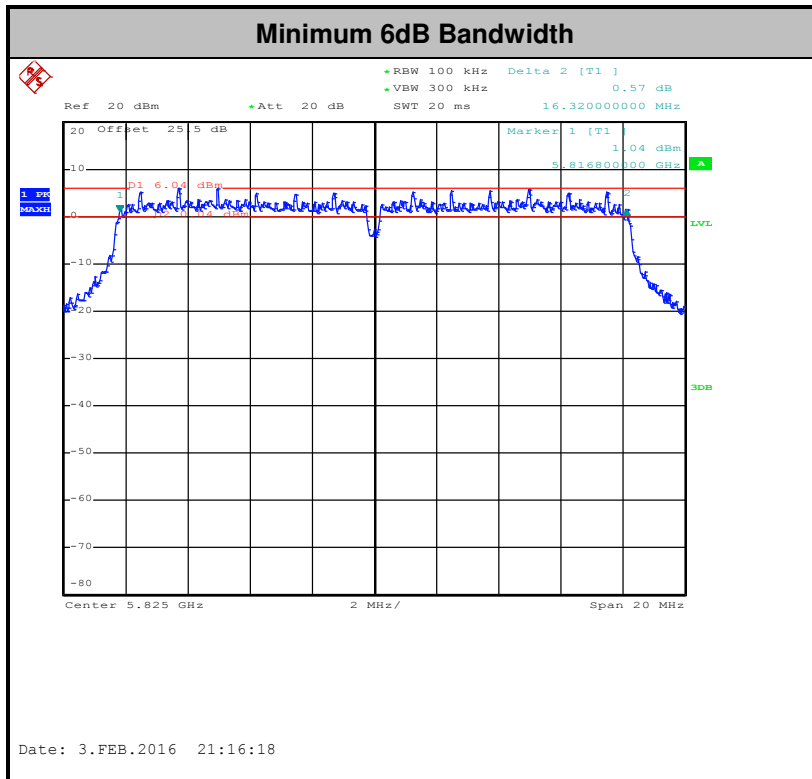

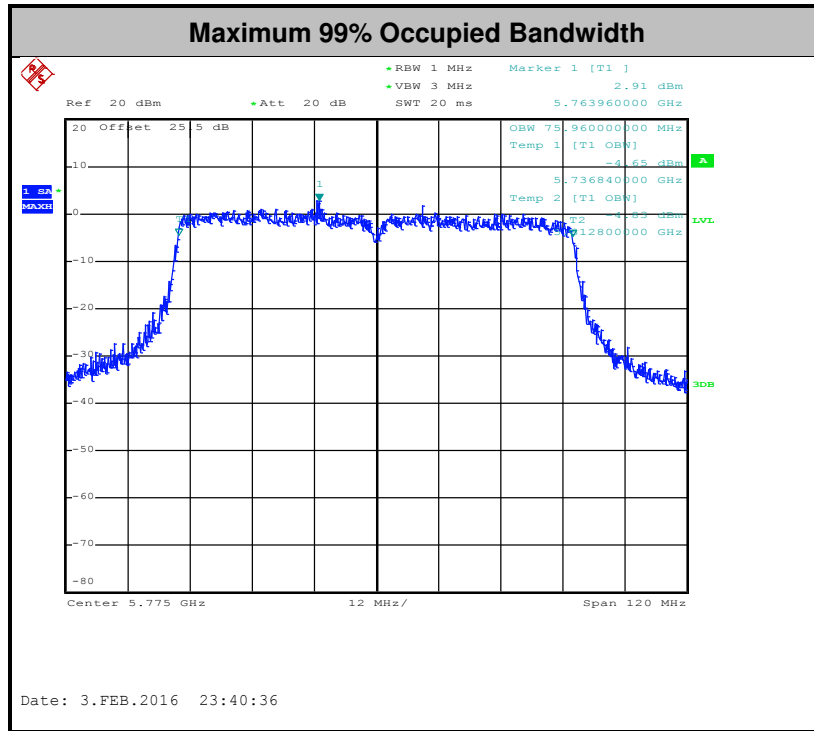

Note: The occupied channel bandwidth is maintained within the band of operation for all of the modulations.

3.2 Maximum Conducted Output Power Measurement

3.2.1 Limit of Maximum Conducted Output Power

For the band 5.725–5.85 GHz, the maximum conducted output power over the frequency band of operation shall not exceed 1 W.

If transmitting antennas of directional gain greater than 6 dBi are used, the peak output power shall be reduced by the amount in dB that the directional gain of the antenna exceeds 6 dBi.

3.2.2 Measuring Instruments

The measuring equipment is listed in the section 4 of this test report.

3.2.3 Test Procedures

The testing follows Method PM of FCC KDB 789033 D02 General UNII Test Procedures New Rules v01r01.

Method PM (Measurement using an RF average power meter):

1. Measurement is performed using a wideband RF power meter.
2. The EUT is configured to transmit continuously with a consistent duty cycle at its maximum power control level.
3. Measure the average power of the transmitter, and the average power is corrected with duty factor, $10 \log(1/x)$, where x is the duty cycle.

3.2.4 Test Setup

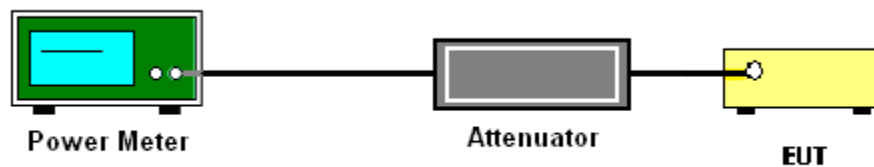

3.2.5 Test Result of Maximum Conducted Output Power

Please refer to Appendix A.



3.3 Power Spectral Density Measurement

3.3.1 Limit of Power Spectral Density

For the band 5.725–5.85 GHz, the maximum power spectral density shall not exceed 30 dBm in any 500-kHz band.

If transmitting antennas of directional gain greater than 6 dBi are used, the peak output power shall be reduced by the amount in dB that the directional gain of the antenna exceeds 6 dBi.

3.3.2 Measuring Instruments

The measuring equipment is listed in the section 4 of this test report.

3.3.3 Test Procedures

The testing follows FCC KDB 789033 D02 General UNII Test Procedures New Rules v01r01. Section F) Maximum power spectral density.

Method SA-2

(trace averaging across on and off times of the EUT transmissions, followed by duty cycle correction).

1. The testing follows Method SA-2 of FCC KDB 789033 D02 General UNII Test Procedures New Rules v01r01.
 - Measure the duty cycle.
 - Set span to encompass the entire emission bandwidth (EBW) of the signal.
 - Set RBW = 300 kHz.
 - Set VBW \geq 1 MHz.
 - Number of points in sweep \geq 2 Span / RBW.
 - Sweep time = auto.
 - Detector = RMS
 - Trace average at least 100 traces in power averaging mode.
 - Add $10 \log(500\text{kHz}/\text{RBW})$ to the test result.
 - Add $10 \log(1/x)$, where x is the duty cycle, to the measured power in order to compute the average power during the actual transmission times. For example, add $10 \log(1/0.25) = 6$ dB if the duty cycle is 25 percent.

2. The RF output of EUT was connected to the spectrum analyzer by a low loss cable.
3. Each plot has already offset with cable loss, and attenuator loss. Measure the PPSD and record it.
4. For **MIMO mode**, calculation method follows FCC KDB 662911 D01 Multiple Transmitter Output v02r01.

Method (a): Measure and sum the spectra across the outputs.

The total final Power Spectral Density is from a device with 2 transmitter outputs. The spectrum measurements of the individual outputs are all performed with the same span and number of points, the spectrum value in the first spectral bin of output 1 is summed with that in the first spectral bin of output 2 to obtain the value for the first frequency bin of the summed spectrum.

3.3.4 Test Setup

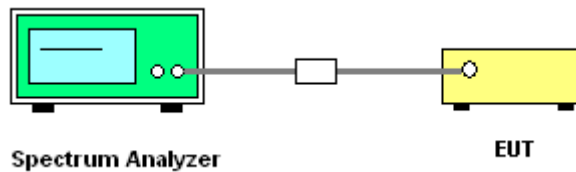



3.3.5 Test Result of Power Spectral Density

Please refer to Appendix A.

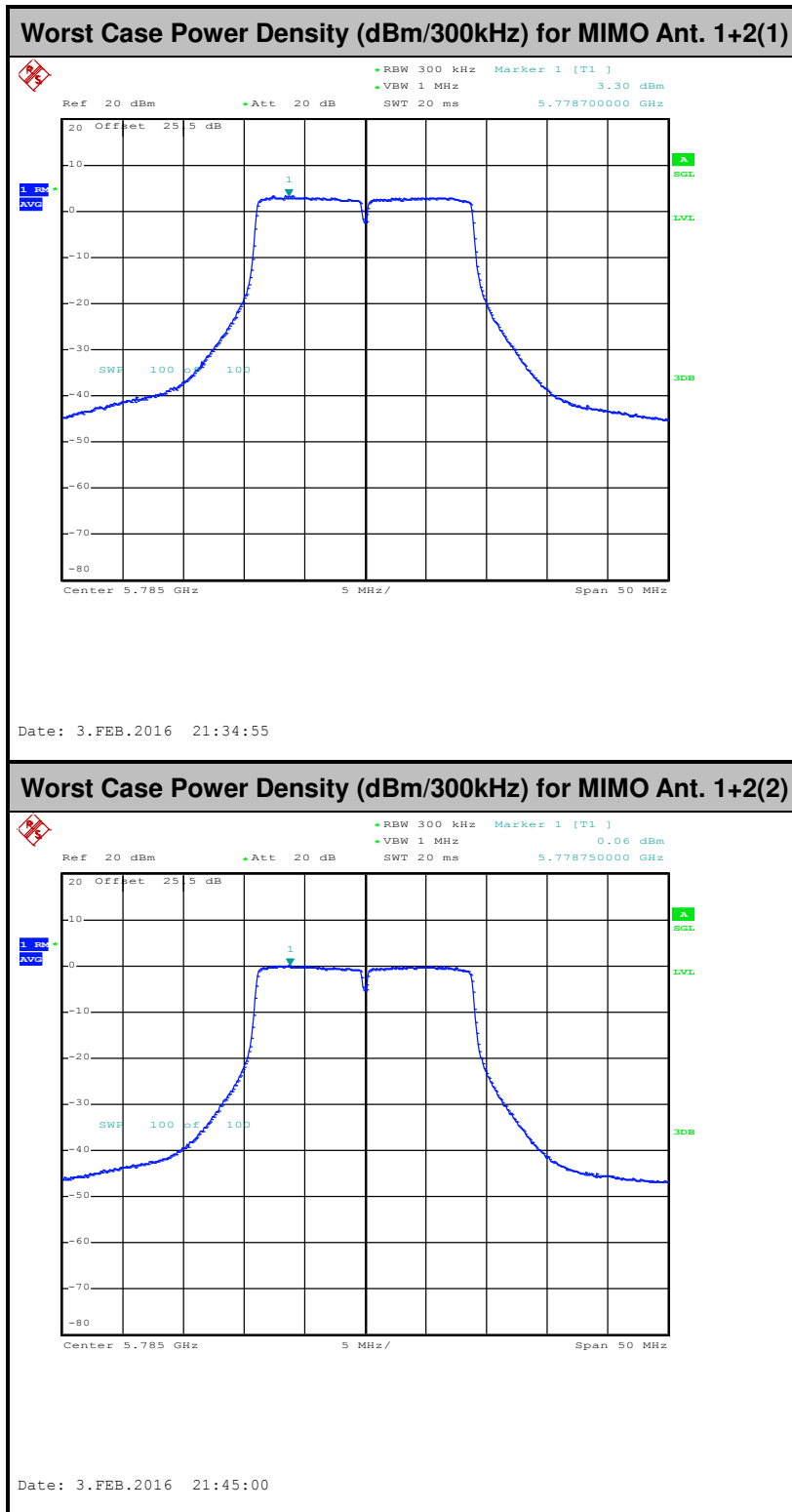



3.4 Unwanted Emissions Measurement

This section as specified in FCC Part 15.407(b) is to measure unwanted emissions through radiated measurement for band edge spurious emissions and out of band emissions measurement. The unwanted emissions shall comply with 15.407(b)(1) to (6), and restricted bands per FCC Part15.205.

3.4.1 Limit of Unwanted Emissions

- (1) For transmitters operating in the 5725-5850 MHz band: all emissions within the frequency range from the band edge to 10 MHz above or below the band edge shall not exceed an EIRP of -17 dBm/MHz (78.3dBµV/m); for frequencies 10 MHz or greater above or below the band edge, emissions shall not exceed an EIRP of -27 dBm/MHz (68.3dBµV/m).
- (2) Unwanted spurious emissions fallen in restricted bands per FCC Part15.205 shall comply with the general field strength limits set forth in § 15.209 as below table,

Frequency (MHz)	Field Strength (microvolts/meter)	Measurement Distance (meters)
0.009 – 0.490	2400/F(kHz)	300
0.490 – 1.705	24000/F(kHz)	30
1.705 – 30.0	30	30
30 – 88	100	3
88 – 216	150	3
216 - 960	200	3
Above 960	500	3

Note: The following formula is used to convert the EIRP to field strength.

$$E = \frac{1000000\sqrt{30P}}{3} \mu\text{V/m, where P is the eirp (Watts)}$$

EIRP (dBm)	Field Strength at 3m (dBµV/m)
-17	78.3
-27	68.3

- (3) KDB 789033 D02 General UNII Test Procedures New Rules v01r01 G)2)c) As specified in 15.407(b), emissions above 1000 MHz that are outside of the restricted bands are subject to a peak emission limit of -27 dBm/MHz (or -17 dBm/MHz as specified in 15.407(b)(4)). However, an out-of-band emission that complies with both the average and peak limits of 15.209 is not required to satisfy the -27 dBm/MHz or -17 dBm/MHz peak emission limit.



3.4.2 Measuring Instruments

The measuring equipment is listed in the section 4 of this test report.

3.4.3 Test Procedures

1. The testing follows FCC KDB 789033 D02 General UNII Test Procedures New Rules v01r01. Section G) Unwanted emissions measurement.

(1) Procedure for Unwanted Emissions Measurements Below 1000MHz

- RBW = 120 kHz
- VBW = 300 kHz
- Detector = Peak
- Trace mode = max hold

(2) Procedure for Peak Unwanted Emissions Measurements Above 1000 MHz

- RBW = 1 MHz
- VBW \geq 3 MHz
- Detector = Peak
- Sweep time = auto
- Trace mode = max hold

(3) Procedures for Average Unwanted Emissions Measurements Above 1000MHz

- RBW = 1 MHz
- VBW = 10 Hz, when duty cycle is no less than 98 percent.
- VBW \geq 1/T, when duty cycle is less than 98 percent where T is the minimum transmission duration over which the transmitter is on and is transmitting at its maximum power control level for the tested mode of operation.



Antenna	Band	Duty Cycle(%)	T(us)	1/T(kHz)	VBW Setting
1+2	5GHz 802.11a for Ant 1	96.18	2016	0.496031746	1kHz
1+2	5GHz 802.11a for Ant 2	96.18	2016	0.496031746	1kHz
1+2	5GHz 802.11n HT20 for Ant 1	96.72	1888	0.529661017	1kHz
1+2	5GHz 802.11n HT20 for Ant 2	95.9	1872	0.534188034	1kHz
1+2	5GHz 802.11n HT40 for Ant 1	93	930	1.075268817	3kHz
1+2	5GHz 802.11n HT40 for Ant 2	93.94	930	1.075268817	3kHz
1+2	5GHz 802.11ac VHT20 for Ant 1	95.94	1888	0.529661017	1kHz
1+2	5GHz 802.11ac VHT20 for Ant 2	95.97	1904	0.525210084	1kHz
1+2	5GHz 802.11ac VHT40 for Ant 1	93.07	940	1.063829787	3kHz
1+2	5GHz 802.11ac VHT40 for Ant 2	93.07	940	1.063829787	3kHz
1+2	5GHz 802.11ac VHT80 for Ant 1	87.36	456	2.192982456	3kHz
1+2	5GHz 802.11ac VHT80 for Ant 2	87.21	450	2.222222222	3kHz



2. The EUT was placed on a turntable with 0.8 meter for frequency below 1GHz and 1.5 meter for frequency above 1GHz respectively above ground.
3. The EUT was set 3 meters from the interference receiving antenna which was mounted on the top of a variable height antenna tower.
4. The antenna is a broadband antenna and its height is adjusted between one meter and four meters above ground to find the maximum value of the field strength for both horizontal polarization and vertical polarization of the antenna.
5. For each suspected emission, the EUT was arranged to its worst case and then adjust the antenna tower (from 1 m to 4 m) and turntable (from 0 degree to 360 degrees) to find the maximum reading.
6. For testing below 1GHz, if the emission level of the EUT in peak mode was 3 dB lower than the limit specified, then peak values of EUT will be reported, otherwise, the emissions will be repeated one by one using the CISPR quasi-peak method and reported.
7. For testing above 1GHz, the emission level of the EUT in peak mode was 20dB lower than average limit (that means the emission level in average mode also complies with the limit in average mode), then peak values of EUT will be reported, otherwise, the emissions will be measured in average mode again and reported.

3.4.4 Test Setup

For radiated emissions below 30MHz

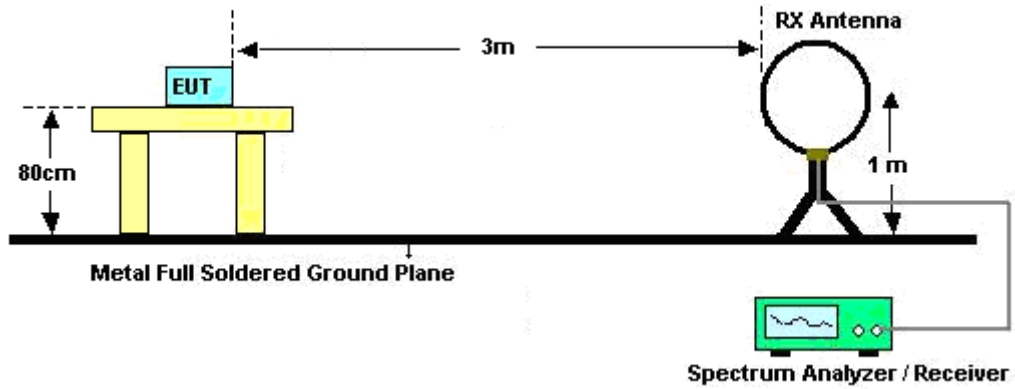

For radiated emissions from 30MHz to 1GHz

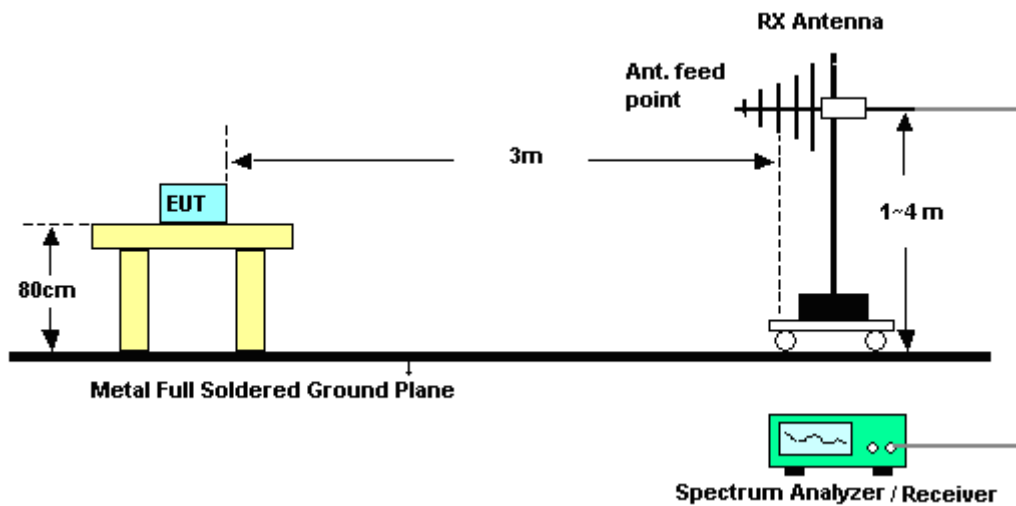

For radiated emissions above 1GHz

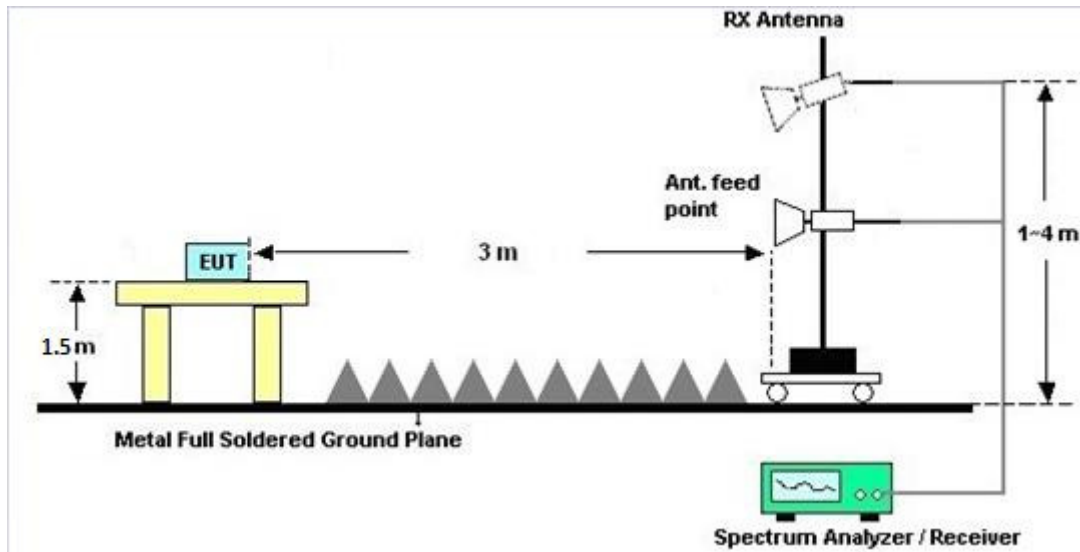

3.4.5 Test Results of Radiated Emissions (9 kHz ~ 30 MHz)

The low frequency, which started from 9 kHz to 30MHz, was pre-scanned and the result which was 20dB lower than the limit line per 15.31(o) was not reported.

3.4.6 Test Result of Radiated Band Edges

Please refer to Appendix B and C.

3.4.7 Test Result of Unwanted Radiated Emission (30MHz ~ 10th Harmonic)

Please refer to Appendix B and C.



3.5 AC Conducted Emission Measurement

3.5.1 Limit of AC Conducted Emission

For equipment that is designed to be connected to the public utility (AC) power line, the radio frequency voltage that is conducted back onto the AC power line on any frequency or frequencies within the band 150 kHz to 30 MHz shall not exceed the limits in the following table.

Frequency of emission (MHz)	Conducted limit (dB μ V)	
	Quasi-peak	Average
0.15-0.5	66 to 56*	56 to 46*
0.5-5	56	46
5-30	60	50

*Decreases with the logarithm of the frequency.

3.5.2 Measuring Instruments

The measuring equipment is listed in the section 4 of this test report.

3.5.3 Test Procedures

1. The EUT was placed 0.4 meter from the conducting wall of the shielding room was kept at least 80 centimeters from any other grounded conducting surface.
2. Connect EUT to the power mains through a line impedance stabilization network (LISN).
3. All the support units are connecting to the other LISN.
4. The LISN provides 50 ohm coupling impedance for the measuring instrument.
5. The FCC states that a 50 ohm, 50 microhenry LISN should be used.
6. Both sides of AC line were checked for maximum conducted interference.
7. The frequency range from 150 kHz to 30 MHz was searched.
8. Set the test-receiver system to Peak Detect Function and specified bandwidth with Maximum Hold Mode.

3.5.4 Test Setup

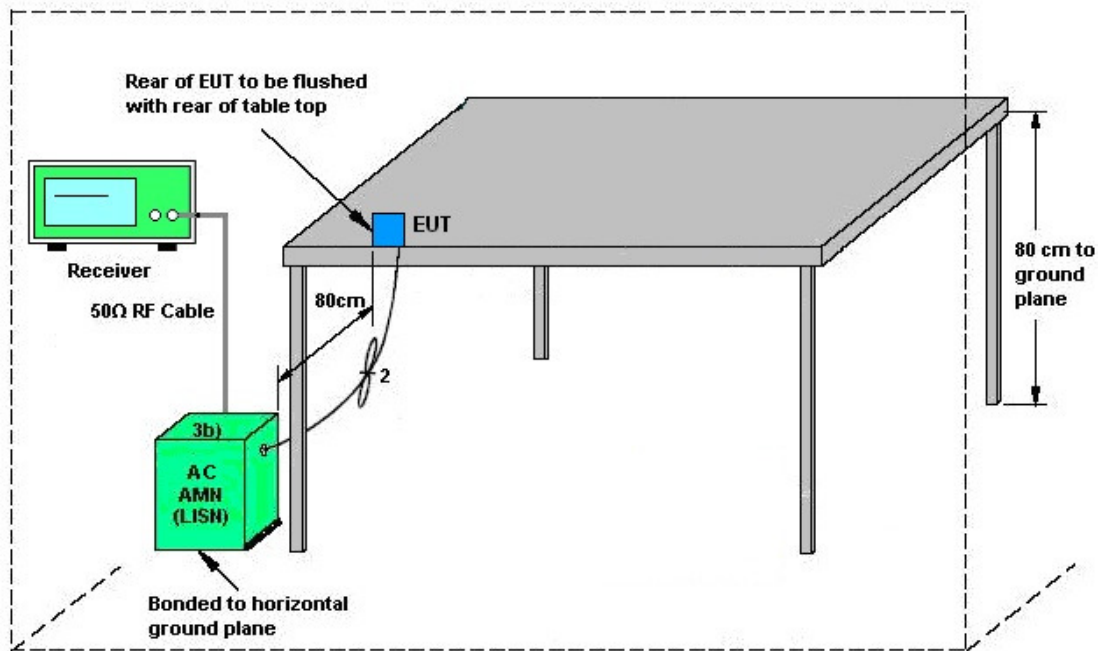

AMN = Artificial mains network (LISN)
AE = Associated equipment
EUT = Equipment under test
ISN = Impedance stabilization network

3.5.5 Test Result of AC Conducted Emission

Test Mode :	Mode 1	Temperature :	24~25°C
Test Engineer :	Kai-Chun Chu	Relative Humidity :	53~25%
Test Voltage :	120Vac / 60Hz	Phase :	Line
Function Type :	5G Tx + RJ-45 Link + Adapter		

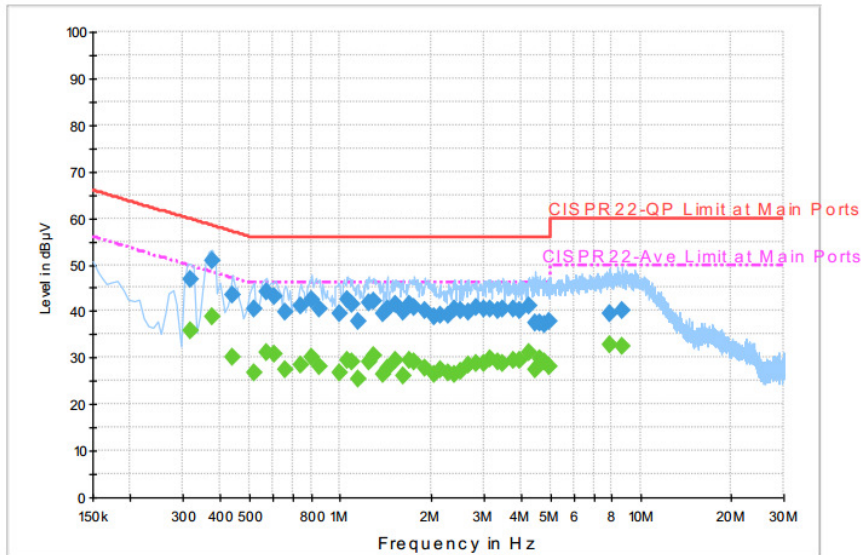

Final Result : QuasiPeak

Frequency (MHz)	QuasiPeak (dBµV)	Filter	Line	Corr. (dB)	Margin (dB)	Limit (dBµV)
0.318000	46.9	Off	L1	19.6	12.9	59.8
0.374000	50.7	Off	L1	19.6	7.7	58.4
0.438000	43.4	Off	L1	19.6	13.7	57.1
0.518000	40.6	Off	L1	19.6	15.4	56.0
0.566000	44.1	Off	L1	19.6	11.9	56.0
0.606000	43.2	Off	L1	19.6	12.8	56.0
0.654000	39.8	Off	L1	19.6	16.2	56.0
0.742000	41.2	Off	L1	19.6	14.8	56.0
0.806000	42.6	Off	L1	19.6	13.4	56.0
0.854000	40.5	Off	L1	19.6	15.5	56.0
0.998000	39.6	Off	L1	19.6	16.4	56.0
1.054000	42.3	Off	L1	19.6	13.7	56.0
1.094000	41.3	Off	L1	19.6	14.7	56.0
1.150000	37.9	Off	L1	19.6	18.1	56.0
1.246000	41.7	Off	L1	19.6	14.3	56.0
1.294000	42.1	Off	L1	19.6	13.9	56.0
1.382000	39.6	Off	L1	19.6	16.4	56.0
1.438000	40.6	Off	L1	19.6	15.4	56.0
1.526000	41.4	Off	L1	19.6	14.6	56.0
1.614000	39.8	Off	L1	19.6	16.2	56.0
1.702000	41.4	Off	L1	19.6	14.6	56.0



Test Mode :	Mode 1	Temperature :	24~25°C
Test Engineer :	Kai-Chun Chu	Relative Humidity :	53~25%
Test Voltage :	120Vac / 60Hz	Phase :	Line
Function Type :	5G Tx + RJ-45 Link + Adapter		

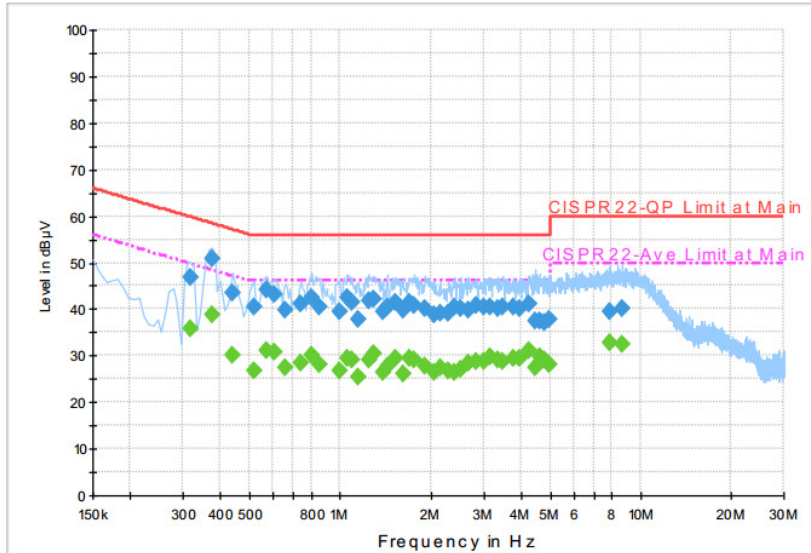

Final Result : QuasiPeak

Frequency (MHz)	QuasiPeak (dBµV)	Filter	Line	Corr. (dB)	Margin (dB)	Limit (dBµV)
1.774000	40.9	Off	L1	19.6	15.1	56.0
1.918000	40.2	Off	L1	19.6	15.8	56.0
2.054000	38.9	Off	L1	18.6	17.1	56.0
2.150000	39.1	Off	L1	18.4	16.9	56.0
2.294000	39.1	Off	L1	18.9	16.9	56.0
2.414000	40.5	Off	L1	19.1	15.5	56.0
2.534000	40.0	Off	L1	19.3	16.0	56.0
2.670000	39.8	Off	L1	19.4	16.2	56.0
2.846000	40.8	Off	L1	19.5	15.2	56.0
3.022000	40.5	Off	L1	19.6	15.5	56.0
3.150000	40.5	Off	L1	19.6	15.5	56.0
3.358000	40.1	Off	L1	19.6	15.9	56.0
3.494000	40.4	Off	L1	19.6	15.6	56.0
3.782000	40.5	Off	L1	19.7	15.5	56.0
3.966000	40.3	Off	L1	19.7	15.7	56.0
4.246000	41.0	Off	L1	19.7	15.0	56.0
4.478000	37.6	Off	L1	19.7	18.4	56.0
4.630000	37.5	Off	L1	19.7	18.5	56.0
4.806000	37.1	Off	L1	19.7	18.9	56.0
4.950000	37.6	Off	L1	19.7	18.4	56.0
7.926000	39.6	Off	L1	19.7	20.4	60.0
8.686000	40.0	Off	L1	19.7	20.0	60.0



Test Mode :	Mode 1	Temperature :	24~25°C
Test Engineer :	Kai-Chun Chu	Relative Humidity :	53~25%
Test Voltage :	120Vac / 60Hz	Phase :	Line
Function Type :	5G Tx + RJ-45 Link + Adapter		

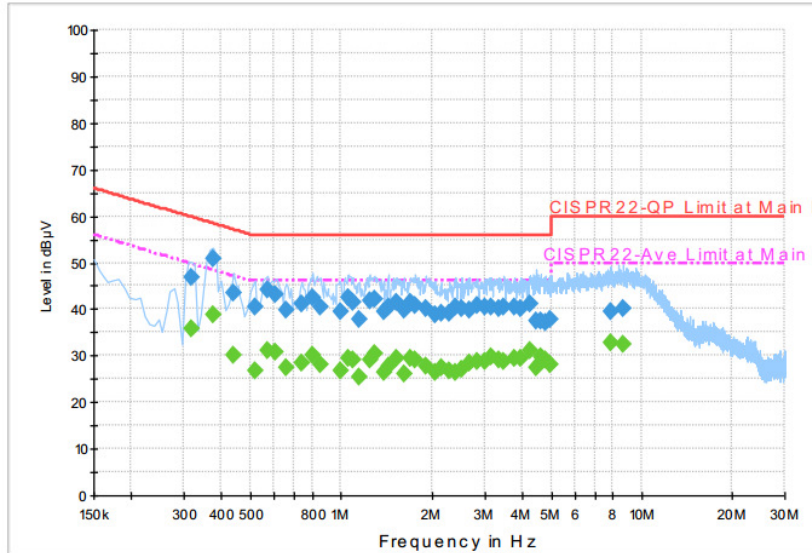

Final Result : Average

Frequency (MHz)	Average (dBµV)	Filter	Line	Corr. (dB)	Margin (dB)	Limit (dBµV)
0.318000	35.8	Off	L1	19.6	14.0	49.8
0.374000	38.8	Off	L1	19.6	9.6	48.4
0.438000	30.0	Off	L1	19.6	17.1	47.1
0.518000	26.8	Off	L1	19.6	19.2	46.0
0.566000	31.2	Off	L1	19.6	14.8	46.0
0.606000	30.6	Off	L1	19.6	15.4	46.0
0.654000	27.5	Off	L1	19.6	18.5	46.0
0.742000	28.5	Off	L1	19.6	17.5	46.0
0.806000	30.1	Off	L1	19.6	15.9	46.0
0.854000	28.2	Off	L1	19.6	17.8	46.0
0.998000	26.8	Off	L1	19.6	19.2	46.0
1.054000	29.5	Off	L1	19.6	16.5	46.0
1.094000	29.0	Off	L1	19.6	17.0	46.0
1.150000	25.6	Off	L1	19.6	20.4	46.0
1.246000	29.0	Off	L1	19.6	17.0	46.0
1.294000	30.3	Off	L1	19.6	15.7	46.0
1.382000	26.5	Off	L1	19.6	19.5	46.0
1.438000	27.6	Off	L1	19.6	18.4	46.0
1.526000	29.4	Off	L1	19.6	16.6	46.0
1.614000	26.0	Off	L1	19.6	20.0	46.0
1.702000	29.4	Off	L1	19.6	16.6	46.0



Test Mode :	Mode 1	Temperature :	24~25°C
Test Engineer :	Kai-Chun Chu	Relative Humidity :	53~25%
Test Voltage :	120Vac / 60Hz	Phase :	Line
Function Type :	5G Tx + RJ-45 Link + Adapter		

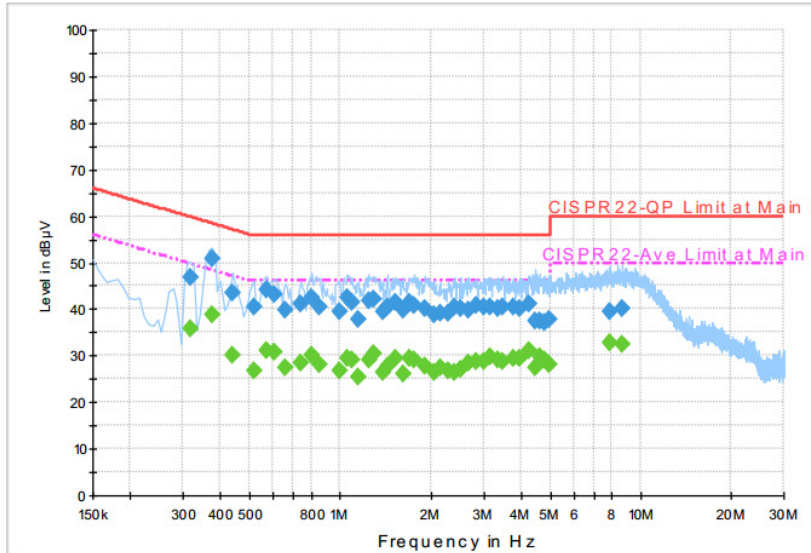

Final Result : Average

Frequency (MHz)	Average (dBµV)	Filter	Line	Corr. (dB)	Margin (dB)	Limit (dBµV)
1.774000	29.2	Off	L1	19.6	16.8	46.0
1.918000	27.9	Off	L1	19.6	18.1	46.0
2.054000	26.3	Off	L1	18.6	19.7	46.0
2.150000	27.6	Off	L1	18.4	18.4	46.0
2.294000	26.6	Off	L1	18.9	19.4	46.0
2.414000	26.3	Off	L1	19.1	19.7	46.0
2.534000	27.3	Off	L1	19.3	18.7	46.0
2.670000	28.5	Off	L1	19.4	17.5	46.0
2.846000	28.7	Off	L1	19.5	17.3	46.0
3.022000	28.9	Off	L1	19.6	17.1	46.0
3.150000	29.9	Off	L1	19.6	16.1	46.0
3.358000	29.1	Off	L1	19.6	16.9	46.0
3.494000	28.7	Off	L1	19.6	17.3	46.0
3.782000	29.6	Off	L1	19.7	16.4	46.0
3.966000	29.4	Off	L1	19.7	16.6	46.0
4.246000	31.1	Off	L1	19.7	14.9	46.0
4.478000	27.6	Off	L1	19.7	18.4	46.0
4.630000	29.6	Off	L1	19.7	16.4	46.0
4.806000	29.0	Off	L1	19.7	17.0	46.0
4.950000	28.0	Off	L1	19.7	18.0	46.0
7.926000	32.6	Off	L1	19.7	17.4	50.0
8.686000	32.3	Off	L1	19.7	17.7	50.0



Test Mode :	Mode 1	Temperature :	24~25°C
Test Engineer :	Kai-Chun Chu	Relative Humidity :	53~25%
Test Voltage :	120Vac / 60Hz	Phase :	Neutral
Function Type :	5G Tx + RJ-45 Link + Adapter		

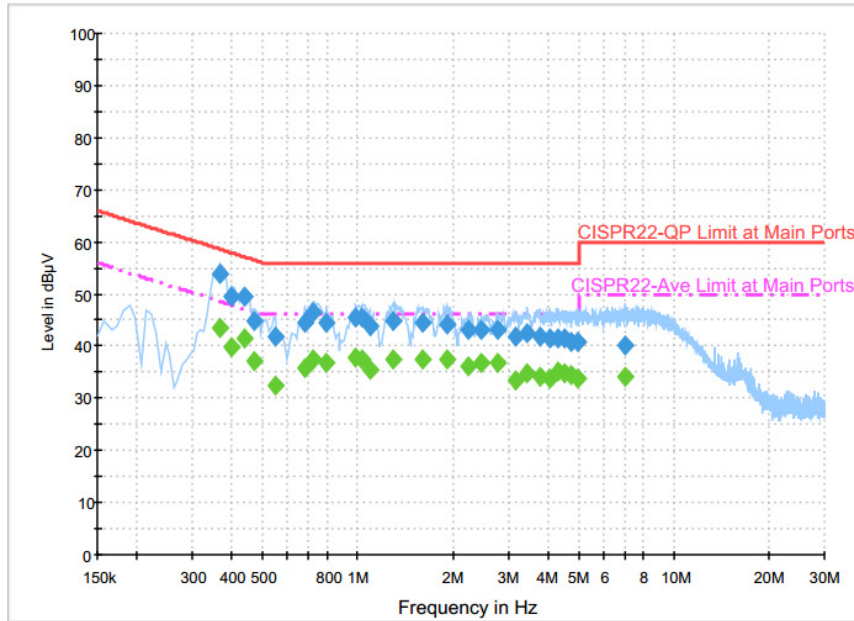

Final Result : QuasiPeak

Frequency (MHz)	QuasiPeak (dBµV)	Filter	Line	Corr. (dB)	Margin (dB)	Limit (dBµV)
0.366000	53.8	Off	N	19.6	4.8	58.6
0.398000	49.5	Off	N	19.6	8.4	57.9
0.438000	49.5	Off	N	19.6	7.6	57.1
0.470000	44.9	Off	N	19.6	11.6	56.5
0.550000	41.6	Off	N	19.6	14.4	56.0
0.678000	44.3	Off	N	19.6	11.7	56.0
0.726000	46.4	Off	N	19.6	9.6	56.0
0.798000	44.5	Off	N	19.6	11.5	56.0
0.990000	45.3	Off	N	19.6	10.7	56.0
1.030000	45.3	Off	N	19.6	10.7	56.0
1.094000	43.7	Off	N	19.6	12.3	56.0
1.294000	44.8	Off	N	19.6	11.2	56.0



Test Mode :	Mode 1	Temperature :	24~25°C
Test Engineer :	Kai-Chun Chu	Relative Humidity :	53~25%
Test Voltage :	120Vac / 60Hz	Phase :	Neutral
Function Type :	5G Tx + RJ-45 Link + Adapter		

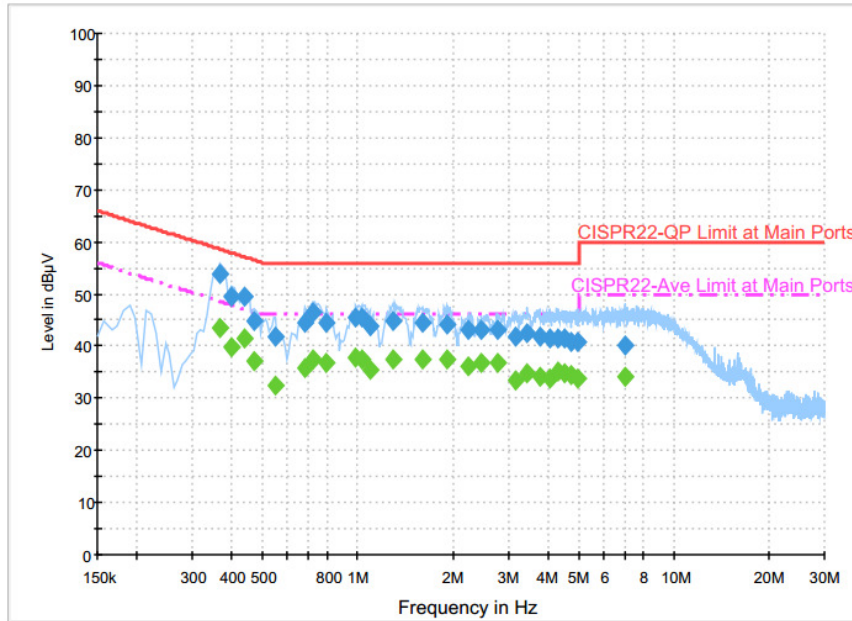

Final Result : QuasiPeak

Frequency (MHz)	QuasiPeak (dBµV)	Filter	Line	Corr. (dB)	Margin (dB)	Limit (dBµV)
1.598000	44.6	Off	N	19.6	11.4	56.0
1.926000	44.1	Off	N	19.6	11.9	56.0
2.230000	43.1	Off	N	18.7	12.9	56.0
2.462000	43.2	Off	N	19.2	12.8	56.0
2.782000	43.0	Off	N	19.5	13.0	56.0
3.174000	41.8	Off	N	19.6	14.2	56.0
3.446000	42.4	Off	N	19.6	13.6	56.0
3.766000	41.7	Off	N	19.6	14.3	56.0
4.070000	41.6	Off	N	19.6	14.4	56.0
4.294000	41.6	Off	N	19.6	14.4	56.0
4.510000	41.5	Off	N	19.7	14.5	56.0
4.766000	40.9	Off	N	19.7	15.1	56.0
4.950000	40.7	Off	N	19.7	15.3	56.0
7.014000	40.3	Off	N	19.7	19.7	60.0



Test Mode :	Mode 1	Temperature :	24~25°C
Test Engineer :	Kai-Chun Chu	Relative Humidity :	53~25%
Test Voltage :	120Vac / 60Hz	Phase :	Neutral
Function Type :	5G Tx + RJ-45 Link + Adapter		

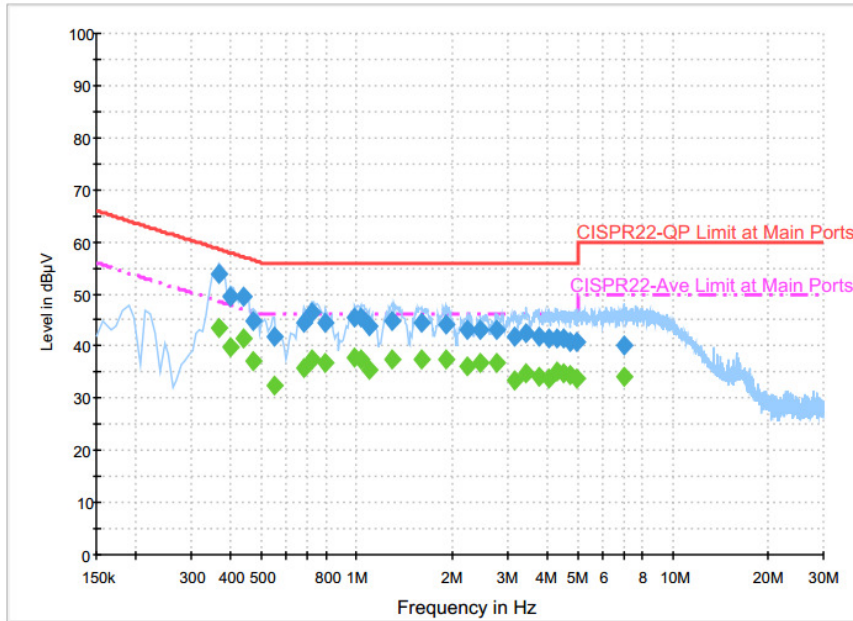

Final Result : Average

Frequency (MHz)	Average (dBµV)	Filter	Line	Corr. (dB)	Margin (dB)	Limit (dBµV)
0.366000	43.3	Off	N	19.6	5.3	48.6
0.398000	39.9	Off	N	19.6	8.0	47.9
0.438000	41.6	Off	N	19.6	5.5	47.1
0.470000	37.0	Off	N	19.6	9.5	46.5
0.550000	32.5	Off	N	19.6	13.5	46.0
0.678000	35.9	Off	N	19.6	10.1	46.0
0.726000	37.5	Off	N	19.6	8.5	46.0
0.798000	36.7	Off	N	19.6	9.3	46.0
0.990000	37.6	Off	N	19.6	8.4	46.0
1.030000	37.4	Off	N	19.6	8.6	46.0
1.094000	35.5	Off	N	19.6	10.5	46.0
1.294000	37.3	Off	N	19.6	8.7	46.0



Test Mode :	Mode 1	Temperature :	24~25°C
Test Engineer :	Kai-Chun Chu	Relative Humidity :	53~25%
Test Voltage :	120Vac / 60Hz	Phase :	Neutral
Function Type :	5G Tx + RJ-45 Link + Adapter		

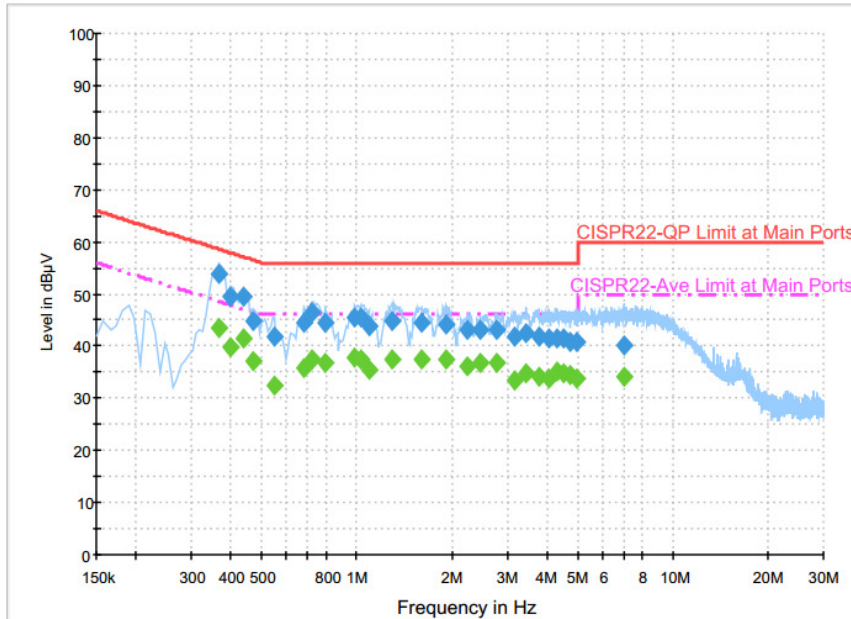

Final Result : Average

Frequency (MHz)	Average (dBµV)	Filter	Line	Corr. (dB)	Margin (dB)	Limit (dBµV)
1.598000	37.6	Off	N	19.6	8.4	46.0
1.926000	37.4	Off	N	19.6	8.6	46.0
2.230000	36.2	Off	N	18.7	9.8	46.0
2.462000	36.8	Off	N	19.2	9.2	46.0
2.782000	36.8	Off	N	19.5	9.2	46.0
3.174000	33.5	Off	N	19.6	12.5	46.0
3.446000	34.8	Off	N	19.6	11.2	46.0
3.766000	34.1	Off	N	19.6	11.9	46.0
4.070000	33.9	Off	N	19.6	12.1	46.0
4.294000	35.1	Off	N	19.6	10.9	46.0
4.510000	34.8	Off	N	19.7	11.2	46.0
4.766000	34.6	Off	N	19.7	11.4	46.0
4.950000	33.8	Off	N	19.7	12.2	46.0
7.014000	34.1	Off	N	19.7	15.9	50.0

3.6 Frequency Stability Measurement

3.6.1 Limit of Frequency Stability

Manufacturers of U-NII devices are responsible for ensuring frequency stability such that an emission is maintained within the band of operation under all conditions of normal operation as specified in the user's manual.

3.6.2 Measuring Instruments

The measuring equipment is listed in the section 4 of this test report.

3.6.3 Test Procedures

1. To ensure emission at the band edge is maintained within the authorized band, those values shall be measured by radiation emissions at upper and lower frequency points, and finally compensated by frequency deviation as procedures below.
2. The EUT was operated at the maximum output power, and connected to the spectrum analyzer, which is set to maximum hold function and peak detector. The peak value of the power envelope was measured and noted. The upper and lower frequency points were respectively measured relatively 10dB lower than the measured peak value.
3. The frequency deviation was calculated by adding the upper frequency point and the lower frequency point divided by two. Those detailed values of frequency deviation are provided in table below.

3.6.4 Test Setup

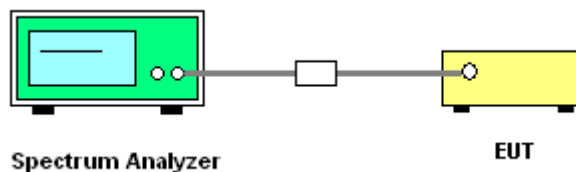

3.6.5 Test Result of Frequency Stability

Please refer to Appendix A.



3.7 Automatically Discontinue Transmission

3.7.1 Limit of Automatically Discontinue Transmission

The device shall automatically discontinue transmission in case of either absence of information to transmit or operational failure. These provisions are not intended to preclude the transmission of control or signaling information or the use of repetitive codes used by certain digital technologies to complete frame or burst intervals. Applicants shall include in their application for equipment authorization to describe how this requirement is met.

3.7.2 Measuring Instruments

The measuring equipment is listed in the section 4 of this test report.

3.7.3 Test Result of Automatically Discontinue Transmission

While the EUT is not transmitting any information, the EUT can automatically discontinue transmission and become standby mode for power saving. The EUT can detect the controlling signal of ACK message transmitting from remote device and verify whether it shall resend or discontinue transmission.



3.8 Antenna Requirements

3.8.1 Standard Applicable

According to FCC 47 CFR Section 15.407(a)(1)(2) ,if transmitting antenna directional gain is greater than 6 dBi, both the peak transmit power and the peak power spectral density shall be reduced by the amount in dB that the directional gain of the antenna exceeds 6 dBi.

3.8.2 Antenna Anti-Replacement Construction

An embedded-in antenna design is used.

3.8.3 Antenna Gain

FCC KDB 662911 D01 Multiple Transmitter Output v02r01

For CDD transmissions, directional gain is calculated as

Directional gain = $G_{ANT} + \text{Array Gain}$, where Array Gain is as follows.

For power spectral density (PSD) measurements on all devices,

Array Gain = $10 \log(N_{ANT}/N_{SS}=1)$ dB.

For power measurements on IEEE 802.11 devices,

Array Gain = 0 dB (i.e., no array gain) for $N_{ANT} \leq 4$.

The EUT supports CDD mode.

The power and PSD limit should be modified if the directional gain of EUT is over 6 dBi,

The directional gain “DG” is calculated as following table.

			DG for Power (dBi)	DG for PSD (dBi)	Power Limit Reduction (dB)	PSD Limit Reduction (dB)
	Ant 1 (dBi)	Ant 2 (dBi)				
Band IV	5.23	5.68	5.68	8.47	0.00	2.47

Power limit reduction = Composite gain – 6dBi, (min = 0)

PSD limit reduction = Composite gain + PSD Array gain – 6dBi, (min = 0)



4 List of Measuring Equipment

Instrument	Manufacturer	Model No.	Serial No.	Characteristics	Calibration Date	Test Date	Due Date	Remark
DC Power Supply	TOPWARD	3303D	740889	N/A	May 27, 2015	Feb. 03, 2016	May 26, 2016	Conducted (TH02-HY)
Power Meter	Anritsu	ML2495A	1036004	300MHz~40GHz	Jul. 29, 2015	Feb. 03, 2016	Jul. 28, 2016	Conducted (TH02-HY)
Power Sensor	Anritsu	MA2411B	1027253	300MHz~40GHz	Jul. 29, 2015	Feb. 03, 2016	Jul. 28, 2016	Conducted (TH02-HY)
Spectrum Analyzer	Rohde & Schwarz	FSP40	100055	9kHz~40GHz	Jun. 18, 2015	Feb. 03, 2016	Jun. 17, 2016	Conducted (TH02-HY)
Loop Antenna	Rohde & Schwarz	HFH2-Z2	100315	9 kHz~30 MHz	Sep. 02, 2015	Jan. 31, 2016 ~ Feb. 03, 2016	Sep. 01, 2016	Radiation (03CH12-HY)
Bilog Antenna	TESEQ	CBL 6111D	37059	30MHz~1GHz	Dec. 29, 2015	Jan. 31, 2016 ~ Feb. 03, 2016	Dec. 28, 2016	Radiation (03CH12-HY)
EMI Test Receiver	Rohde & Schwarz	ESU26	100390	20Hz~26.5GHz	Dec. 21, 2015	Jan. 31, 2016 ~ Feb. 03, 2016	Dec. 20, 2016	Radiation (03CH12-HY)
Horn Antenna	SCHWARZBECK	BBHA 9120D	9120D-1328	1GHz ~ 18GHz	Nov. 02, 2015	Jan. 31, 2016 ~ Feb. 03, 2016	Nov. 01, 2016	Radiation (03CH12-HY)
Horn Antenna	SCHWARZBECK	BBHA 9170	BBHA9170584	18GHz- 40GHz	Nov. 02, 2015	Jan. 31, 2016 ~ Feb. 03, 2016	Nov. 01, 2016	Radiation (03CH12-HY)
Preamplifier	COM-POWER	PA-103A	161075	10MHz~1GHz	Apr. 09, 2015	Jan. 31, 2016 ~ Feb. 03, 2016	Apr. 08, 2016	Radiation (03CH12-HY)
Preamplifier	MITEQ	AMF-7D-0010 1800-30-10P	1815698	1GHz~18GHz	Dec. 14, 2015	Jan. 31, 2016 ~ Feb. 03, 2016	Dec. 13, 2016	Radiation (03CH12-HY)
Preamplifier	Agilent	8449B	3008A02375	1GHz~26.5GHz	Jan. 05, 2016	Jan. 31, 2016 ~ Feb. 03, 2016	Jan. 04, 2017	Radiation (03CH12-HY)
Controller	EMEC	EM1000	N/A	Control Turn table & Ant Mast	N/A	Jan. 31, 2016 ~ Feb. 03, 2016	N/A	Radiation (03CH12-HY)
Antenna Mast	EMEC	AM-BS-4500-B	N/A	1m~4m	N/A	Jan. 31, 2016 ~ Feb. 03, 2016	N/A	Radiation (03CH12-HY)
Turn Table	EMEC	TT2000	N/A	0-360 degree	N/A	Jan. 31, 2016 ~ Feb. 03, 2016	N/A	Radiation (03CH12-HY)
Preamplifier	MITEQ	JS44-1800400 0-33-8P	1840917	18GHz ~ 40GHz	Jun. 02, 2015	Jan. 31, 2016 ~ Feb. 03, 2016	Jun. 01, 2016	Radiation (03CH12-HY)



Instrument	Manufacturer	Model No.	Serial No.	Characteristics	Calibration Date	Test Date	Due Date	Remark
AC Power Source	ChainTek	APC-1000W	N/A	N/A	N/A	Feb. 03, 2016	N/A	Conduction (CO05-HY)
EMI Test Receiver	Rohde & Schwarz	ESCI 7	100724	9kHz~7GHz	Aug. 26, 2015	Feb. 03, 2016	Aug. 25, 2016	Conduction (CO05-HY)
LISN	Rohde & Schwarz	ENV216	100080	9kHz~30MHz	Dec. 02, 2015	Feb. 03, 2016	Dec. 01, 2016	Conduction (CO05-HY)
Pulse Limiter	Rohde & Schwarz	ESH3-Z2	100851	N/A	Jan. 08, 2016	Feb. 03, 2016	Jan. 07, 2017	Conduction (CO05-HY)



5 Uncertainty of Evaluation

Uncertainty of Conducted Emission Measurement (150kHz ~ 30MHz)

Measuring Uncertainty for a Level of Confidence of 95% ($U = 2Uc(y)$)	2.26
---	------

Uncertainty of Radiated Emission Measurement (30 MHz ~ 1000 MHz)

Measuring Uncertainty for a Level of Confidence of 95% ($U = 2Uc(y)$)	4.90
---	------



Appendix A. Conducted Test Results