

FCC Test Report

FCC ID : HDC-17600074
Equipment : WiFi 7 10G Router
Model No. : SDG-8733, SDG-8734
(Please refer to section 1.1.1 for more details)
Brand Name : Adtran
Applicant : Adtran
Address : 901 Explorer Boulevard, Huntsville, Alabama,
United States, 35806-2807
Standard : 47 CFR FCC Part 15.407
Received Date : Mar. 13, 2024
Tested Date : Mar. 13 ~ Apr. 26, 2024

We, International Certification Corporation, would like to declare that the tested sample has been evaluated and in compliance with the requirement of the above standards. The test results contained in this report refer exclusively to the product. It shall not be reproduced except in full without the written approval of our laboratory.

Reviewed by:

Approved by:

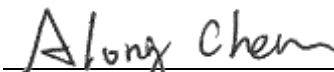

Along Chen / Assistant Manager



Gary Chang / Manager

Table of Contents

1	GENERAL DESCRIPTION	5
1.1	Information.....	5
1.2	Local Support Equipment List	12
1.3	Test Setup Chart	13
1.4	The Equipment List	17
1.5	Test Standards	18
1.6	Reference Guidance	18
1.7	Deviation from Test Standard and Measurement Procedure.....	18
1.8	Measurement Uncertainty	19
2	TEST CONFIGURATION	20
2.1	Testing Facility.....	20
2.2	The Worst Test Modes and Channel Details	21
3	TRANSMITTER TEST RESULTS.....	23
3.1	Emission Bandwidth	23
3.2	Conducted Output Power	24
3.3	Power Spectral Density	26
3.4	Unwanted Emissions.....	28
3.5	Frequency Stability.....	31
3.6	AC Power Line Conducted Emissions	32
4	TEST LABORATORY INFORMATION	33
Appendix A. Emission Bandwidth		
Appendix B. Conducted Output Power		
Appendix C. Power Spectral Density		
Appendix D. Unwanted Emissions		
Appendix E. Frequency Stability		
Appendix F. AC Power Line Conducted Emissions		

Release Record

Report No.	Version	Description	Issued Date
FR431301AN	Rev. 01	Initial issue	May 24, 2024

Summary of Test Results

FCC Rules	Test Items	Measured	Result
15.207	AC Power Line Conducted Emissions	[dBuV]: 0.437MHz 34.99 (Margin -12.12dB) - AV	Pass
15.407(b) 15.209	Unwanted Emissions	[dBuV/m at 3m]: 5150.00MHz 53.88 (Margin -0.12dB) – AV	Pass
15.407(a)	Emission Bandwidth	Meet the requirement of limit	Pass
15.407(e)	6dB bandwidth	Meet the requirement of limit	Pass
15.407(a)	Conducted Output Power	Max Power [dBm]: Non-beamforming mode 5150~5250MHz: 28.02 5250~5350MHz: 23.35 5470~5725MHz: 23.73 5725~5850MHz: 29.00 Beamforming mode 5150~5250MHz: 26.98 5250~5350MHz: 23.85 5470~5725MHz: 23.71 5725~5850MHz: 28.79	Pass
15.407(a)	Power Spectral Density	Meet the requirement of limit	Pass
15.407(g)	Frequency Stability	Meet the requirement of limit	Pass
15.203	Antenna Requirement	Meet the requirement of limit	Pass

Declaration of Conformity:

The test results with all measurement uncertainty excluded are presented in accordance with the regulation limits or requirements declared by manufacturers.

Comments and Explanations:

The declared of product specification for EUT presented in the report are provided by the manufacturer, and the manufacturer takes all the responsibilities for the accuracy of product specification.

1 General Description

1.1 Information

1.1.1 Product Details

The following models are provided to this EUT.

Brand Name	Model Name	Product Name	Description
Adtran	SDG-8733	WiFi 7 10G Router	W/O VOIP, With 10G RJ45 WAN Port
	SDG-8734	WiFi 7 10G Router	W/O VOIP, With 10G SFP WAN Port

1.1.2 Specification of the Equipment under Test (EUT)

RF General Information					
Frequency Range (MHz)	IEEE Std. 802.11	Ch. Freq. (MHz)	Channel Number	Transmit Chains (N _{TX})	Data Rate / MCS
5150-5250 5250-5350 5470-5725 5725-5850	a	5180-5240 5260-5320 5500-5720 5745-5825	36-48 [4] 52-64 [4] 100-144 [12] 149-165 [5]	4	6-54 Mbps
5150-5250 5250-5350 5470-5725 5725-5850	n (HT20)	5180-5240 5260-5320 5500-5720 5745-5825	36-48 [4] 52-64 [4] 100-144 [12] 149-165 [5]	4	MCS 0-31
5150-5250 5250-5350 5470-5725 5725-5850	n (HT40)	5190-5230 5270-5310 5510-5710 5755-5795	38-46 [2] 54-62 [2] 102-142 [6] 151-159 [2]	4	MCS 0-31
5150-5250 5250-5350 5470-5725 5725-5850	ac (VHT20)	5180-5240 5260-5320 5500-5720 5745-5825	36-48 [4] 52-64 [4] 100-144 [12] 149-165 [5]	4	MCS 0-9
5150-5250 5250-5350 5470-5725 5725-5850	ac (VHT40)	5190-5230 5270-5310 5510-5710 5755-5795	38-46 [2] 54-62 [2] 102-142 [6] 151-159 [2]	4	MCS 0-9
5150-5250 5250-5350 5470-5725 5725-5850	ac (VHT80)	5210 5290 5530~5690 5775	42 [1] 58 [1] 106-138 [3] 155 [1]	4	MCS 0-9
5150-5250 5250-5350 5470-5725	ac (VHT160)	5250 5570	50 [1] 114 [1]	4	MCS 0-11
5150-5250 5250-5350 5470-5725 5725-5850	ax (HE20)	5180-5240 5260-5320 5500-5720 5745-5825	36-48 [4] 52-64 [4] 100-144 [12] 149-165 [5]	4	MCS 0-11

5150-5250 5250-5350 5470-5725 5725-5850	ax (HE40)	5190-5230 5270-5310 5510-5710 5755-5795	38-46 [2] 54-62 [2] 102-142 [6] 151-159 [2]	4	MCS 0-11
5150-5250 5250-5350 5470-5725 5725-5850	ax (HE80)	5210 5290 5530~5690 5775	42 [1] 58 [1] 106-138 [3] 155 [1]	4	MCS 0-11
5150-5250 5250-5350 5470-5725	ax (HE160)	5250 5570	50 [1] 114 [1]	4	MCS 0-11
5150-5250 5250-5350 5470-5725 5725-5850	be (EHT20)	5180-5240 5260-5320 5500-5720 5745-5825	36-48 [4] 52-64 [4] 100-144 [12] 149-165 [5]	4	MCS 0-13
5150-5250 5250-5350 5470-5725 5725-5850	be (EHT40)	5190-5230 5270-5310 5510-5710 5755-5795	38-46 [2] 54-62 [2] 102-142 [6] 151-159 [2]	4	MCS 0-13
5150-5250 5250-5350 5470-5725 5725-5850	be (EHT80)	5210 5290 5530~5690 5775	42 [1] 58 [1] 106-138 [3] 155 [1]	4	MCS 0-13
5150-5250 5250-5350 5470-5725	be (EHT160)	5250 5570	50 [1] 114 [1]	4	MCS 0-13
Note 1: OFDM/OFDMA- BPSK, QPSK, 16QAM, 64QAM, 256QAM, 1024QAM and 4096QAM modulation.					

1.1.3 Antenna Details

Ant. No.	Model	Type	Connector	Operating Frequencies (MHz) / Antenna Gain (dBi)				
				2400~2483.5	5150~5250	5250~5350	5470~5725	5725 ~ 5850
1	DB1	Dipole	UFL	3.948	5.688	5.607	5.316	4.309
2	DB2	Dipole	UFL	4.92	4.627	4.569	5.03	5.17
3	DB3	Dipole	UFL	3.842	4.597	5.481	6.018	4.796
4	DB4	Dipole	UFL	5.006	6.346	6.51	5.997	5.982
5	SM-DFS	Dipole	UFL	4.092	5.909	5.909	5.159	5.526

1.1.4 Configuration of Equipment under Test (EUT)

Power Supply Type	15Vdc from adapter	
TPC	<input checked="" type="checkbox"/> Support	<input type="checkbox"/> Not support
Beamforming	<input checked="" type="checkbox"/> Support	<input type="checkbox"/> Not support
RU Configuration	<input checked="" type="checkbox"/> Full RU	<input type="checkbox"/> Partial RU
Channel Puncturing	<input type="checkbox"/> Support	<input checked="" type="checkbox"/> Not support

1.1.5 Accessories

Accessories		
No.	Equipment	Description
1	AC adapter	Brand: LUCENT TRANS Model: 1A78 I/P: 100-240Vac, 50/60Hz, 1.2A O/P: 15V= 3.0A, 45.0W Power Line: USB 1.8m non-shielded without core
2	AC adapter	Brand: PHIHONG Model: AA45A-59FKD I/P: 100-240Vac, 50/60Hz, 1.2A O/P: 15V=3.0A, 45.0W Power Line: USB 1.8m non-shielded without core
3	RJ45	2m non-shielded without core

1.1.6 Channel List

802.11a / n HT20 / ac VHT20 / ax HE20 / be EHT20		802.11n HT40 / ac VHT40 / ax HE40 / be EHT40	
Channel	Frequency(MHz)	Channel	Frequency(MHz)
36	5180	38	5190
40	5200	46	5230
44	5220	54	5270
48	5240	62	5310
52	5260	102	5510
56	5280	110	5550
60	5300	118	5590
64	5320	126	5630
100	5500	134	5670
104	5520	151	5755
108	5540	159	5795
112	5560	802.11ac VHT80 / ax HE80 / be EHT80	
116	5580	42	5210
120	5600	58	5290
124	5620	106	5530
128	5640	122	5610
132	5660	155	5775
136	5680	802.11ac VHT160 / ax HE160 / be EHT160	
140	5700	50	5250
149	5745	114	5570
153	5765	---	---
157	5785	---	---
161	5805	---	---
165	5825	---	---

1.1.7 Test Tool and Duty Cycle

Test Tool	Non-beamforming: QATool, 0.0.2.99 Beamforming: Putty, 0.6				
Duty Cycle and Duty Factor	Mode	Non-beamforming		Beamforming	
		Duty cycle (%)	Duty factor (dB)	Duty cycle (%)	Duty factor (dB)
	11a	98.96%	0.05	---	---
	be EHT20	98.92%	0.05	99.62%	0.02
	be EHT40	98.61%	0.06	98.41%	0.07
	be EHT80	96.30%	0.16	96.53%	0.15
be EHT160	94.00%	0.27	91.75%	0.37	

1.1.8 Power Index of Test Tool

Modulation Mode	Test Frequency (MHz)	Power Index	
		Non-beamforming	Beamforming
11a	5180	19.5	---
11a	5200	23	---
11a	5240	23	---
11a	5260	15.5	---
11a	5300	15.5	---
11a	5320	15.5	---
11a	5500	16.5	---
11a	5580	17.5	---
11a	5700	16	---
11a	5720	16.5	---
11a	5745	23	---
11a	5785	23	---
11a	5825	23	---
be EHT20	5180	20	39
be EHT20	5200	21.5	43
be EHT20	5240	22.5	43
be EHT20	5260	16	32
be EHT20	5300	16	32
be EHT20	5320	15.5	32
be EHT20	5500	17	33
be EHT20	5580	17.5	36
be EHT20	5700	16.5	33
be EHT20	5720	17	34
be EHT20	5745	23	46
be EHT20	5785	23	46
be EHT20	5825	23	46

Modulation Mode	Test Frequency (MHz)	Power Index	
		Non-beamforming	Beamforming
be EHT40	5190	17.5	36
be EHT40	5230	23	43
be EHT40	5270	16	34
be EHT40	5310	16	33
be EHT40	5510	17.5	36
be EHT40	5590	18	36
be EHT40	5670	17	34
be EHT40	5710	17.5	35
be EHT40	5755	20.5	41
be EHT40	5795	21.5	42
be EHT80	5210	17	34
be EHT80	5290	14	28
be EHT80	5530	18.5	37
be EHT80	5610	18.5	37
be EHT80	5690	17.5	35
be EHT80	5775	17	34
be EHT160	5250	13	26
be EHT160	5570	15	30

1.2 Local Support Equipment List

Support Equipment List					
No.	Equipment	Brand	Model	FCC ID	Remarks
Non-beamforming mode - RJ45 WAN					
1	Laptop	DELL	Latitude 5400	DoC	---
2	Laptop	DELL	Latitude 5400	DoC	---
3	USB Flash	Transcend(USB 3.0)	JetFlash 700	---	---
4	RJ45 Connector	ICC	---	---	---
5	RJ45 Load	ICC	---	---	---
6	Laptop	DELL	Latitude 3440	DoC	Beamforming mode
7	WiFi 7 10G Router	Adtran	SDG-8733	---	Beamforming mode (Provided by applicant)
Non-beamforming mode - SFP WAN					
1	Laptop	DELL	Latitude 5400	DoC	---
2	USB Flash	Transcend(USB 3.0)	JetFlash 700	---	---
3	RJ45 Connector	ICC	---	---	---
4	RJ45 Load	ICC	---	---	---
5	Fiber module	MikroTik	S+RJ10	---	Provided by applicant
6	Laptop	DELL	Latitude 3440	DoC	Beamforming mode
7	WiFi 7 10G Router	Adtran	SDG-8733	---	Beamforming mode (Provided by applicant)

1.3 Test Setup Chart

Non-beamforming mode

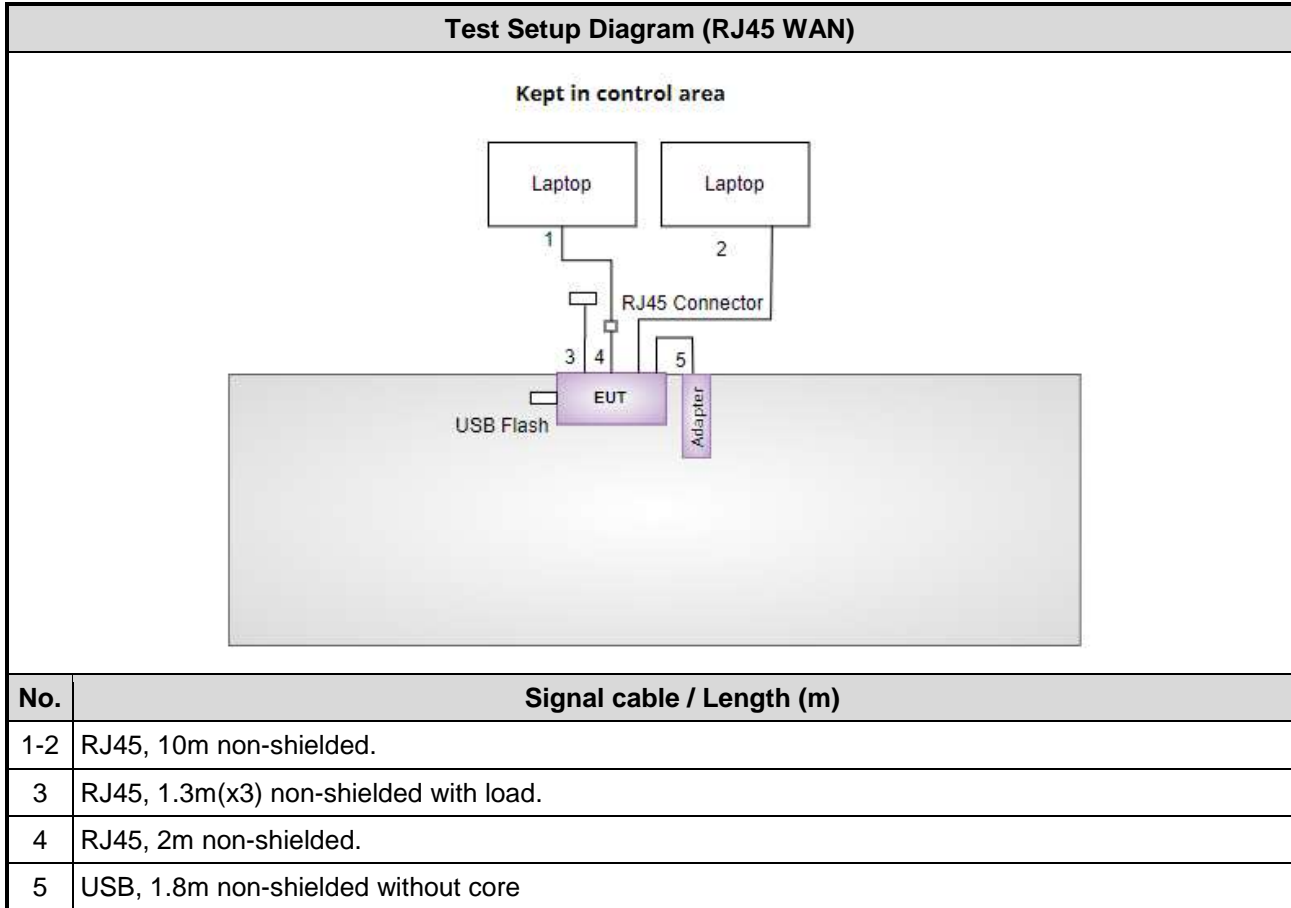

Test Setup Diagram (SFP WAN)

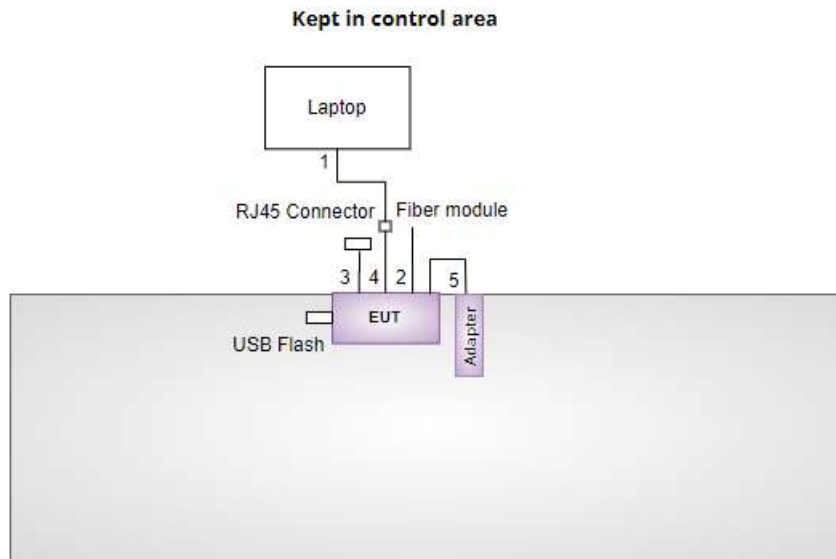

No.	Signal cable / Length (m)
1	RJ45, 10m non-shielded.
2	RJ45, 2m non-shielded.
3	RJ45, 1.3m(x3) non-shielded with load.
4	RJ45, 2m non-shielded.
5	USB, 1.8m non-shielded without core

Beamforming mode

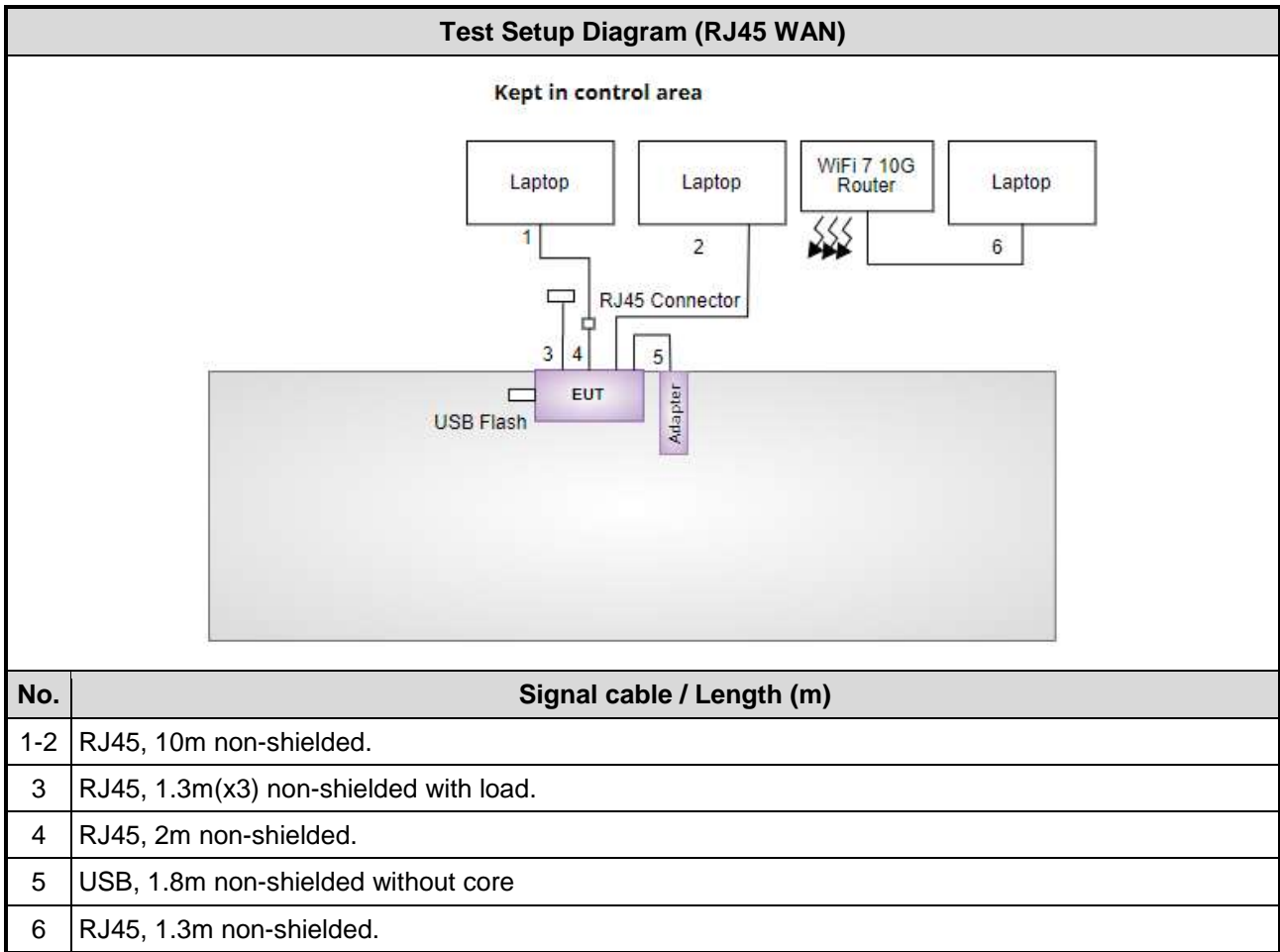

Test Setup Diagram (SFP WAN)

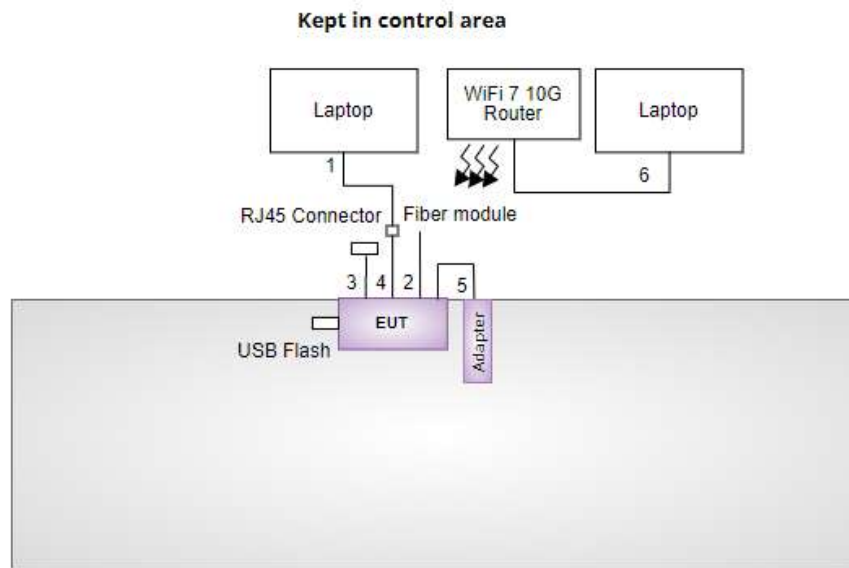

No.	Signal cable / Length (m)
1	RJ45, 10m non-shielded.
2	RJ45, 2m non-shielded.
3	RJ45, 1.3m(x3) non-shielded with load.
4	RJ45, 2m non-shielded.
5	USB, 1.8m non-shielded without core
6	RJ45, 1.3m non-shielded.

1.4 The Equipment List

Test Item	Conducted Emission				
Test Site	Conduction room 1 / (CO01-WS)				
Tested Date	Apr. 19, 2024				
Instrument	Brand	Model No.	Serial No.	Calibration Date	Calibration Until
Receiver	R&S	ESR3	101658	Feb. 23, 2024	Feb. 22, 2025
LISN	R&S	ENV216	101579	May 09, 2023	May 08, 2024
RF Cable-CON	Woken	CFD200-NL	CFD200-NL-001	Oct. 11, 2023	Oct. 10, 2024
LISN (Support Unit)	SCHWARZBECK	Schwarzbeck 8127	8127667	Jan. 10, 2024	Jan. 09, 2025
50 ohm terminal (Support Unit)	NA	50	01	Jun. 14, 2023	Jun. 13, 2024
Measurement Software	AUDIX	e3	6.120210k	NA	NA
Note: Calibration Interval of instruments listed above is one year.					

Test Item	Radiated Emission				
Test Site	966 chamber1 / (03CH01-WS)				
Tested Date	Mar. 13 ~ Apr. 15, 2024				
Instrument	Brand	Model No.	Serial No.	Calibration Date	Calibration Until
Receiver	R&S	ESR3	101657	Mar. 05, 2024	Mar. 04, 2025
Spectrum Analyzer	R&S	FSV40	101498	Nov. 23, 2023	Nov. 22, 2024
Loop Antenna	R&S	HFH2-Z2	100330	Oct. 31, 2023	Oct. 30, 2024
Bilog Antenna	SCHWARZBECK	VULB9168	VULB9168-522	Jul. 31, 2023	Jul. 30, 2024
Horn Antenna 1G-18G	SCHWARZBECK	BBHA 9120 D	BBHA 9120 D 1096	Nov. 27, 2023	Nov. 26, 2024
Horn Antenna 18G-40G	SCHWARZBECK	BBHA 9170	BBHA 9170517	Oct. 30, 2023	Oct. 29, 2024
Preamplifier	EMC	EMC02325	980225	Jun. 28, 2023	Jun. 27, 2024
Preamplifier	EMC	EMC118A45SE	980898	Jul. 14, 2023	Jul. 13, 2024
Preamplifier	EMC	EMC184045SE	980903	Jul. 17, 2023	Jul. 16, 2024
Loop Antenna Cable	KOAX KABEL	101354-BW	101354-BW	Oct. 03, 2023	Oct. 02, 2024
LF cable 3M	Woken	CFD400NL-LW	CFD400NL-001	Oct. 03, 2023	Oct. 02, 2024
LF cable 11M	EMC	EMCCFD400-NW-N W-11000	200801	Oct. 03, 2023	Oct. 02, 2024
LF cable 1M	EMC	EMCCFD400-NM-N M-1000	160502	Oct. 03, 2023	Oct. 02, 2024
RF Cable	EMC	EMC104-35M-35M-8000	210920	Oct. 03, 2023	Oct. 02, 2024
RF Cable	EMC	EMC104-35M-35M-3000	210922	Oct. 03, 2023	Oct. 02, 2024
HIGHPASS FILTER 7-18G	K&L	11SH10-7000/T1800 0-O/OP	18	Oct. 05, 2023	Oct. 04, 2024
Attenuator	Pasternack	PE7005-10	10-1	Oct. 05, 2023	Oct. 04, 2024
Measurement Software	AUDIX	e3	6.120210g	NA	NA
Note: Calibration Interval of instruments listed above is one year.					

Test Item	RF Conducted				
Test Site	(TH01-WS)				
Tested Date	Mar. 18 ~ Apr. 26, 2024				
Instrument	Brand	Model No.	Serial No.	Calibration Date	Calibration Until
Spectrum Analyzer	R&S	FSV40	101498	Nov. 23, 2023	Nov. 22, 2024
Power Meter	Anritsu	ML2495A	1241002	Nov. 21, 2023	Nov. 20, 2024
Power Sensor	Anritsu	MA2411B	1207366	Nov. 21, 2023	Nov. 20, 2024
TEMP&HUMIDITY CHAMBER	GIANT FORCE	GCT-225-40-SP-SD	MAF1212-002	Jun. 21, 2023	Jun. 20, 2024
AC POWER SOURCE	APC	AFC-500W	F312060012	Dec. 16, 2023	Dec. 15, 2024
Attenuator	Pasternack	PE7005-10	10-2	Oct. 05, 2023	Oct. 04, 2024
Measurement Software	Sporton	SENSE-15407_NII	V5.11	NA	NA
Note: Calibration Interval of instruments listed above is one year.					

1.5 Test Standards

47 CFR FCC Part 15.407
ANSI C63.10-2013

1.6 Reference Guidance

FCC KDB 412172 D01 Determining ERP and EIRP v01r01
FCC KDB 662911 D01 Multiple Transmitter Output v02r01
FCC KDB 789033 D02 General UNII Test Procedures New Rules v02r01

1.7 Deviation from Test Standard and Measurement Procedure

None

1.8 Measurement Uncertainty

The measurement uncertainties given below are based on a 95% confidence level (based on a coverage factor (k=2)).

Measurement Uncertainty	
Parameters	Uncertainty
Bandwidth	±34.130 Hz
Conducted power	±0.808 dB
Frequency error	±1×10 ⁻⁹
Power density	±0.583 dB
Conducted emission	±2.715 dB
AC conducted emission	±2.92 dB
Unwanted Emission ≤ 1GHz	±3.41 dB
Unwanted Emission > 1GHz	±4.59 dB
Time	±0.1%
Temperature	±0.4 °C

2 Test Configuration

2.1 Testing Facility

Test Laboratory	International Certification Corporation
Test Site	CO01-WS, 03CH01-WS, TH01-WS
Address of Test Site	No.3-1, Lane 6, Wen San 3rd St., Kwei Shan Dist., Tao Yuan City 33381, Taiwan (R.O.C.)

- FCC Designation No.: TW2732
- FCC site registration No.: 181692
- ISED#: 10807A
- CAB identifier: TW2732

2.2 The Worst Test Modes and Channel Details

Non-beamforming mode

Frequency band 5150~5350 MHz / 5470~5725 MHz				
Test item	Modulation Mode	Test Frequency (MHz)	Data Rate	Test Configuration
AC Power Line Conducted Emissions	be EHT40	5230	MCS 0	1, 2
Unwanted Emissions ≤1GHz	be EHT40	5230	MCS 0	1, 2
Unwanted Emissions >1GHz Conducted Output Power Emission Bandwidth Power Spectral Density	11a	5180 / 5200 / 5240 / 5260 / 5300 5320 / 5500 / 5580 / 5700 / 5720	6 Mbps	1
	be EHT20	5180 / 5200 / 5240 / 5260 / 5300 5320 / 5500 / 5580 / 5700 / 5720	MCS 0	
	be EHT40	5190 / 5230 / 5270 / 5310 / 5510 5590 / 5670 / 5710	MCS 0	
	be EHT80	5210 / 5290 / 5530 / 5610 / 5690	MCS 0	
	be EHT160	5250 / 5570	MCS 0	
Frequency Stability	Un-modulation	5300	---	1
Frequency band 5725-5850 MHz				
Test item	Modulation Mode	Test Frequency (MHz)	Data Rate	Test Configuration
AC Power Line Conducted Emissions	11a	5745	6 Mbps	1, 2
Unwanted Emissions ≤1GHz	11a	5745	6 Mbps	1, 2
Unwanted Emissions >1GHz Conducted Output Power Emission Bandwidth 6dB bandwidth Power Spectral Density	11a	5745 / 5785 / 5825	6 Mbps	1
	be EHT20	5745 / 5785 / 5825	MCS 0	
	be EHT40	5755 / 5795	MCS 0	
	be EHT80	5775	MCS 0	
Frequency Stability	Un-modulation	5785	---	1
NOTE:				
1. Two adapters (LUCENT TRANS & PHIHONG) had been covered during the pretest and found that PHIHONG adapter was the worst case for radiated emission test and LUCENT TRANS adapter was the worst case for conducted emission test.				
2. The EUT had been tested by following test configurations.				
1) Configuration 1: Model: SDG-8733				
2) Configuration 2: Model: SDG-8734				

Beamforming mode

Frequency band 5150~5350 MHz / 5470~5725 MHz				
Test item	Modulation Mode	Test Frequency (MHz)	Data Rate	Test Configuration
AC Power Line Conducted Emissions	be EHT20	5240	MCS 0	1, 2
Unwanted Emissions ≤1GHz	be EHT20	5240	MCS 0	1, 2
Unwanted Emissions >1GHz Conducted Output Power Emission Bandwidth Power Spectral Density	be EHT20	5180 / 5200 / 5240 / 5260 / 5300 5320 / 5500 / 5580 / 5700 / 5720	MCS 0	1
	be EHT40	5190 / 5230 / 5270 / 5310 / 5510 5590 / 5670 / 5710	MCS 0	
	be EHT80	5210 / 5290 / 5530 / 5610 / 5690	MCS 0	
	be EHT160	5250 / 5570	MCS 0	
Frequency band 5725-5850 MHz				
Test item	Modulation Mode	Test Frequency (MHz)	Data Rate	Test Configuration
AC Power Line Conducted Emissions	be EHT20	5745	MCS 0	1, 2
Unwanted Emissions ≤1GHz	be EHT20	5745	MCS 0	1, 2
Unwanted Emissions >1GHz Conducted Output Power Emission Bandwidth 6dB bandwidth Power Spectral Density	be EHT20	5745 / 5785 / 5825	MCS 0	1
	be EHT40	5755 / 5795	MCS 0	
	be EHT80	5775	MCS 0	
NOTE:				
1. Two adapters (LUCENT TRANS & PHIHONG) had been covered during the pretest and found that PHIHONG adapter was the worst case for radiated emission test and LUCENT TRANS adapter was the worst case for conducted emission test.				
2. The EUT had been tested by following test configurations.				
1) Configuration 1: Model: SDG-8733				
2) Configuration 2: Model: SDG-8734				

3 Transmitter Test Results

3.1 Emission Bandwidth

3.1.1 Limit of Emission Bandwidth

Within the 5.725-5.85 GHz band, the minimum 6 dB bandwidth of U-NII devices shall be at least 500 kHz.

3.1.2 Test Procedures

26dB Bandwidth

1. Set RBW = approximately 1% of the emission bandwidth.
2. Set the VBW > RBW, Detector = Peak.
3. Trace mode = max hold.
4. Measure the maximum width of the emission that is 26 dB down from the peak of the emission.

Occupied Bandwidth

1. Set RBW = 1 % to 5 % of the OBW.
2. Set VBW \geq 3 RBW.
3. Sample detection and single sweep mode shall be used.
4. Use the 99 % power bandwidth function of the instrument.

6dB Bandwidth

1. Set RBW = 100kHz, VBW = 300kHz.
2. Detector = Peak, Trace mode = max hold.
3. Allow the trace to stabilize.
4. Measure the maximum width of the emission that is constrained by the frequencies associated with the two outermost amplitude points (upper and lower frequencies) that are attenuated by 6 dB relative to the maximum level measured in the fundamental emission.

3.1.3 Test Setup

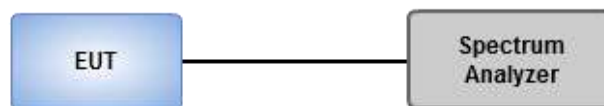

3.1.4 Test Results

Ambient Condition	22-24°C / 63-66%	Tested By	Akun Chung
--------------------------	------------------	------------------	------------

Refer to Appendix A.

3.2 Conducted Output Power

3.2.1 Limit of Conducted Output Power

Frequency band 5150-5250 MHz		
Operating Mode		Limit
<input type="checkbox"/>	Outdoor access point	Conducted Power: 1 W The maximum e.i.r.p. at any elevation angle above 30 degrees as measured from the horizon must not exceed 125 mW (21 dBm)
<input checked="" type="checkbox"/>	Indoor access point	Conducted Power: 1 W
<input type="checkbox"/>	Fixed point-to-point access points	Conducted Power: 1 W
<input type="checkbox"/>	Client devices	Conducted Power: 250 mW

Frequency Band (MHz)		Limit
<input checked="" type="checkbox"/>	5250 ~ 5350	Conducted Power: 250mW or 11dBm+10 log B
<input checked="" type="checkbox"/>	5470 ~ 5725	Conducted Power: 250mW or 11dBm+10 log B
<input checked="" type="checkbox"/>	5725 ~ 5850	Conducted Power: 1 W

Note: "B" is the 26dB emission bandwidth in MHz.

3.2.2 Test Procedures

Method PM-G (Measurement using a gated RF average power meter)

Measurements is performed using a wideband gated RF power meter provided that the gate parameters are adjusted such that the power is measured only when the EUT is transmitting at its maximum power control level. Since the measurement is made only during the ON time of the transmitter, no duty cycle correction factor is required.

Spectrum analyzer (For channel that extends across the 5.725 GHz boundary)

1. Set RBW = 1MHz, VBW = 3MHz, Sweep time = Auto, Detector = RMS.
2. Trace average at least 100 traces in power averaging mode.
3. Compute power by integrating the spectrum across the 26 dB EBW.
4. Add $10 \log(1/X)$, X:duty cycle) if duty cycle is <98%).

3.2.3 Test Setup

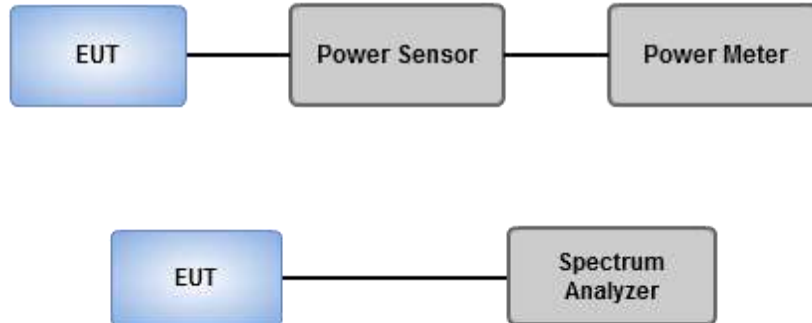

3.2.4 Test Results

Ambient Condition	22-24°C / 63-66%	Tested By	Akun Chung
--------------------------	------------------	------------------	------------

Refer to Appendix B.

3.3 Power Spectral Density

3.3.1 Limit of Power Spectral Density

Frequency band 5150-5250 MHz		
Operating Mode		Limit
<input type="checkbox"/>	Outdoor access point	17 dBm / MHz
<input checked="" type="checkbox"/>	Indoor access point	17 dBm / MHz
<input type="checkbox"/>	Fixed point-to-point access points	17 dBm / MHz
<input type="checkbox"/>	Client devices	11 dBm / MHz

Frequency Band (MHz)		Limit
<input checked="" type="checkbox"/>	5250 ~ 5350	11 dBm / MHz
<input checked="" type="checkbox"/>	5470 ~ 5725	11 dBm / MHz
<input checked="" type="checkbox"/>	5725 ~ 5850	30 dBm /500 kHz

3.3.2 Test Procedures

For 5150 ~ 5250 MHz / 5250 ~ 5350 MHz / 5470 ~ 5725 MHz

Duty cycle \geq 98 %

1. Set RBW = 1 MHz, VBW = 3 MHz, Sweep time = auto, Detector = RMS.
2. Trace average 100 traces.
3. Use the peak marker function to determine the maximum amplitude level.

Duty cycle $<$ 98 %

1. Set RBW = 1 MHz, VBW = 3 MHz, Detector = RMS.
2. Set sweep time $\geq 10 * (\text{number of points in sweep}) * (\text{total on/off period of the transmitted signal})$.
3. Perform a single sweep.
4. Use the peak marker function to determine the maximum amplitude level.
5. Add $10 \log(1/x)$, where x is the duty cycle.

For 5725 ~ 5850 MHz

Duty cycle \geq 98 %

1. Set RBW = 500 kHz, VBW = 3 MHz, Sweep time = auto, Detector = RMS.
2. Trace average 100 traces.
3. Use the peak marker function to determine the maximum amplitude level.

Duty cycle $<$ 98 %

1. Set RBW = 500 kHz, VBW = 3 MHz, Detector = RMS.
2. Set sweep time $\geq 10 * (\text{number of points in sweep}) * (\text{total on/off period of the transmitted signal})$.
3. Perform a single sweep.
4. Use the peak marker function to determine the maximum amplitude level.
5. Add $10 \log(1/x)$, where x is the duty cycle.

3.3.3 Test Setup

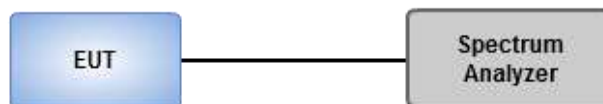

3.3.4 Test Results

Ambient Condition	22-24°C / 63-66%	Tested By	Akun Chung
--------------------------	------------------	------------------	------------

Refer to Appendix C.

3.4 Unwanted Emissions

3.4.1 Limit of Unwanted Emissions

Restricted Band Emissions Limit			
Frequency Range (MHz)	Field Strength (uV/m)	Field Strength (dBuV/m)	Measure Distance (m)
0.009~0.490	2400/F(kHz)	48.5 - 13.8	300
0.490~1.705	24000/F(kHz)	33.8 - 23	30
1.705~30.0	30	29	30
30~88	100	40	3
88~216	150	43.5	3
216~960	200	46	3
Above 960	500	54	3

Note 1:
Qusai-Peak value is measured for frequency below 1GHz except for 9–90 kHz, 110–490 kHz frequency band. Peak and average value are measured for frequency above 1GHz. The limit on average radio frequency emission is as above table. The limit on peak radio frequency emissions is 20 dB above the maximum permitted average emission limit

Note 2:
Measurements may be performed at a distance other than what is specified provided. When performing measurements at a distance other than that specified, the results shall be extrapolated to the specified distance using an extrapolation factor as below, Frequency at or above 30 MHz: 20 dB/decade Frequency below 30 MHz: 40 dB/decade.

Un-restricted band emissions above 1GHz Limit	
Operating Band	Limit
5.15 - 5.25 GHz	e.i.r.p. -27 dBm [68.2 dBuV/m@3m]
5.25 - 5.35 GHz	e.i.r.p. -27 dBm [68.2 dBuV/m@3m]
5.47 - 5.725 GHz	e.i.r.p. -27 dBm [68.2 dBuV/m@3m]
5.725 - 5.850 GHz	All emissions shall be limited to a level of -27 dBm/MHz at 75 MHz or more above or below the band edge increasing linearly to 10 dBm/MHz at 25 MHz above or below the band edge, and from 25 MHz above or below the band edge increasing linearly to a level of 15.6 dBm/MHz at 5 MHz above or below the band edge, and from 5 MHz above or below the band edge increasing linearly to a level of 27 dBm/MHz at the band edge.

Note 1: Measurements may be performed at a distance other than the limit distance provided they are not performed in the near field and the emissions to be measured can be detected by the measurement equipment. When performing measurements at a distance other than that specified, the results shall be extrapolated to the specified distance using an extrapolation factor of 20 dB/decade (inverse of linear distance for field-strength measurements, inverse of linear distance-squared for power-density measurements).

3.4.2 Test Procedures

1. Measurement is made at a semi-anechoic chamber that incorporates a turntable allowing a EUT rotation of 360°. A continuously-rotating, remotely-controlled turntable is installed at the test site to support the EUT and facilitate determination of the direction of maximum radiation for each EUT emission frequency. The EUT is placed at test table. For emissions testing at or below 1 GHz, the table height is 80 cm above the reference ground plane. For emission measurements above 1 GHz, the table height is 1.5 m
2. Measurement is made with the antenna positioned in both the horizontal and vertical planes of polarization. The measurement antenna is varied in height (1m ~ 4m) above the reference ground plane to obtain the maximum signal strength. Distance between EUT and antenna is 3 m.
3. This investigation is performed with the EUT rotated 360°, the antenna height scanned between 1 m and 4 m, and the antenna rotated to repeat the measurements for both the horizontal and vertical antenna polarizations.

Note:

1. 120kHz measurement bandwidth of test receiver and Quasi-peak detector is for radiated emission below 1GHz.
2. RBW=1MHz, VBW=3MHz and Peak detector is for peak measured value of radiated emission above 1GHz.
3. RBW=1MHz, VBW=1/T and Peak detector is for average measured value of radiated emission above 1GHz.

3.4.3 Test Setup

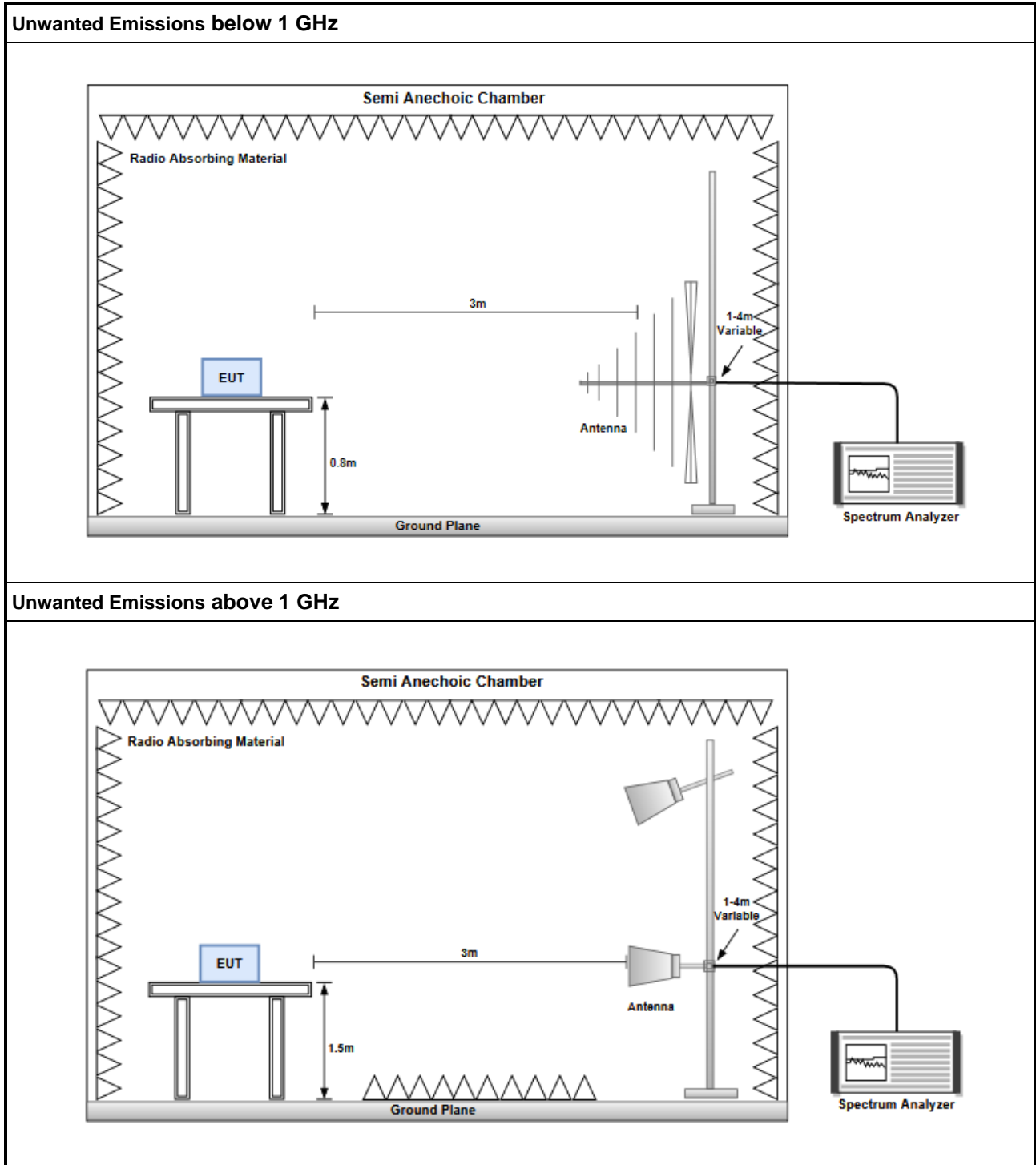

3.4.4 Test Results

Refer to Appendix D.

3.5 Frequency Stability

3.5.1 Limit of Frequency Stability

Manufacturers of U-NII devices are responsible for ensuring frequency stability such that an emission is maintained within the band of operation under all conditions of normal operation as specified in the user's manual.

3.5.2 Test Procedures

1. The EUT is installed in an environment test chamber with external power source.
2. Set the chamber to operate at 20 centigrade and external power source to output at nominal voltage of EUT.
3. A sufficient stabilization period at each temperature is used prior to each frequency measurement.
4. When temperature is stabled, measure the frequency stability.
5. The test shall be performed under normal and extreme condition for temperature and voltage.

3.5.3 Test Setup

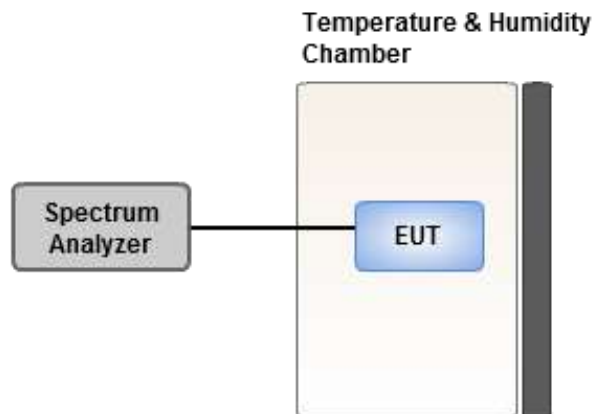

3.5.4 Test Results

Ambient Condition	22-24°C / 63-66%	Tested By	Akun Chung
--------------------------	------------------	------------------	------------

Refer to Appendix E.

3.6 AC Power Line Conducted Emissions

3.6.1 Limit of AC Power Line Conducted Emissions

Conducted Emissions Limit		
Frequency Emission (MHz)	Quasi-Peak	Average
0.15-0.5	66 - 56 *	56 - 46 *
0.5-5	56	46
5-30	60	50

Note 1: * Decreases with the logarithm of the frequency.

3.6.2 Test Procedures

1. The device is placed on a test table, raised 80 cm above the reference ground plane. The vertical conducting plane is located 40 cm to the rear of the device.
2. The device is connected to line impedance stabilization network (LISN) and other accessories are connected to other LISN. Measured levels of AC power line conducted emission are across the 50 Ω LISN port.
3. AC conducted emission measurements is made over frequency range from 150 kHz to 30 MHz.
4. This measurement was performed with AC 120V/60Hz

3.6.3 Test Setup

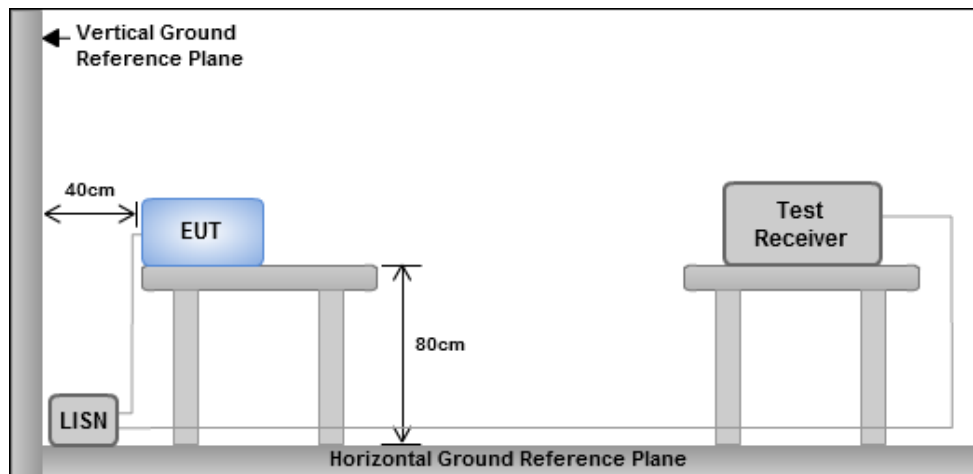

- Note: 1. Support units were connected to second LISN.
 2. Both of LISNs (AMN) are 80 cm from EUT and at least 80 cm from other units and other metal planes

3.6.4 Test Results

Refer to Appendix F.

4 Test laboratory information

Established in 2012, ICC provides foremost EMC & RF Testing and advisory consultation services by our skilled engineers and technicians. Our services employ a wide variety of advanced edge test equipment and one of the widest certification extents in the business.

International Certification Corporation (EMC and Wireless Communication Laboratory), it is our definitive objective is to institute long term, trust-based associations with our clients. The expectation we set up with our clients is based on outstanding service, practical expertise and devotion to a certified value structure. Our passion is to grant our clients with best EMC / RF services by oriented knowledgeable and accommodating staff.

Our Test sites are located at Linkou District and Kwei Shan District. Location map can be found on our website <http://www.icertifi.com.tw>.

Linkou

Tel: 886-2-2601-1640

No.30-2, Ding Fwu Tsuen, Lin Kou
District, New Taipei City, Taiwan
(R.O.C.)

Kwei Shan

Tel: 886-3-271-8666

No.3-1, Lane 6, Wen San 3rd
St., Kwei Shan Dist., Tao Yuan
City 33381, Taiwan (R.O.C.)
No.2-1, Lane 6, Wen San 3rd
St., Kwei Shan Dist., Tao Yuan
City 33381, Taiwan (R.O.C.)

Kwei Shan Site II

Tel: 886-3-271-8640

No.14-1, Lane 19, Wen San 3rd
St., Kwei Shan Dist., Tao Yuan
City 33381, Taiwan (R.O.C.)

If you have any suggestion, please feel free to contact us as below information.

Tel: 886-3-271-8666

Fax: 886-3-318-0345

Email: ICC_Service@icertifi.com.tw

==END==