

## TEST REPORT

Report Number: 100030468ATL-001

March 9, 2010

**Product Designation: RLR-0003-1**

Standard: FCC Part 15.250 - Operation of wideband systems within the band 5925 to 7250 MHz

**Tested by:**

Intertek Testing Services NA Inc.  
1950 Evergreen Blvd., Suite 100  
Duluth, GA 30096

**Client:**

Sutron Corporation  
22400 Davis Drive  
Sterling, VA 20164  
Contact: Chris Buchner  
Phone: 703.406.2800

**Tests performed by:**



Richard C. Bianco  
EMC Project Engineer

**Report reviewed by:**



Jeremy O. Pickens  
EMC Department Manager

All services undertaken are subject to the following general policy: This report is for the exclusive use of Intertek's Client and is provided pursuant to the agreement between Intertek and its Client. Intertek's responsibility and liability are limited to the terms and conditions of the agreement. Intertek assumes no liability to any party, other than to the Client in accordance with the agreement, for any loss, expense or damage occasioned by the use of this report. Only the Client is authorized to copy or distribute this report and then only in its entirety. Any use of the Intertek name or one of its marks for the sale or advertisement of the tested material, product or service must first be approved in writing by Intertek. The observations and test results in this report are relevant only to the sample tested. This report by itself does not imply that the material, product, or service is or has ever been under an Intertek certification program. This report must not be used to claim product endorsement by A2LA, NIST, or any agency of the US Government.

## 1.0 Introduction and Conclusion

The tests indicated in section 2.0 were performed on the product constructed as described in section 3.0. The remaining test sections are the verbatim text from the actual data sheets used during the investigation. These test sections include the test name, the specified test Method, a list of the actual Test Equipment Used, documentation Photos, Results and raw Data. No additions, deviations, or exclusions have been made from the standard(s) unless specifically noted.

Based on the results of our investigation, we have concluded the product tested complies with the requirements of the standard(s) indicated. The results obtained in this test report pertain only to the item(s) tested.

## 2.0 Test Summary

Section	Test Full Name	Test Date	Result
4.0	System setup including cable interconnection details, support equipment and simplified block diagram. (System Setup)		
5.0	15.250(a) and 15.250(b): -10 dB Bandwidth requirements (Bandwidth)	02/23/2010	PASS
6.0	15.250(d)(1) Radiated power (EIRP) density (EIRP power density)	02/24/2010	PASS
7.0	Peak Power in a 50 MHz bandwidth (Peak Power per 50 MHz)	02/23/2010	PASS
8.0	Radiated emissions below 960 MHz (Radiated Emissions (<960 MHz))	02/23/2010	PASS
9.0	15.250(d)(2) Radiated power (EIRP) density in GPS receive bands (EIRP power density (GPS))	02/23/2010	PASS

### 3.0 Description of Equipment Under Test

Equipment Under Test			
Description	Manufacturer	Model Number	Serial Number
Radar Level Recorder	Sutron	RLR-0003-1	NA

EUT receive date:	02/18/2010
EUT receive condition:	Good

Description of EUT provided by Client:

A Precision water level measuring instrument using radar pulses to measure levels without direct contact with water, the RLR can be located on a bridge, pier or any structure over the water's surface.

Description of EUT exercising:

The EUT was placed in a continuous transmit state during testing.

## 4.0 System setup including cable interconnection details, support equipment and simplified block diagram. (System Setup)

### Method:

Record the details of EUT cabling, document the support equipment, and show the interconnections in a block diagram.

### Drawing:

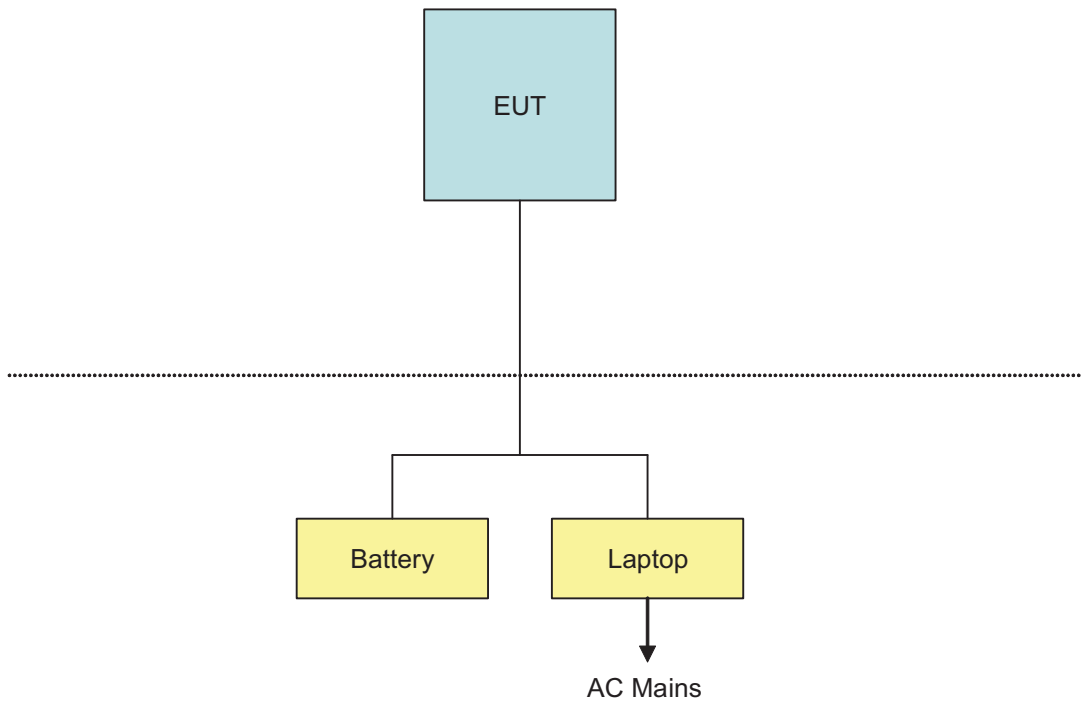

Simplified Block Diagram

#### 4.0 System setup including cable interconnection details, support equipment and simplified block diagram. (System Setup)

##### Data:

EUT Cabling						
ID	Description	Length	Shielding	Ferrites	Connection	
					From	To
A	RS232	10m	No	No	EUT	Battery/Laptop support

Support Equipment			
Description	Manufacturer	Model Number	Serial Number
Battery	Werker	WKA12-80C/FR	K40401A
Laptop	Dell	Client equipment	Client equipment

**5.0 15.250(a) and 15.250(b): -10 dB Bandwidth requirements (Bandwidth)**

**Method:**

The -10 dB bandwidth of a device operating under the provisions of this section must be contained within the 5925-7250 MHz band under all conditions of operation including the effects from stepped frequency, frequency hopping or other modulation techniques that may be employed as well as the frequency stability of the transmitter over expected variations in temperature and supply voltage.

The -10 dB bandwidth of the fundamental emission shall be at least 50 MHz. For transmitters that employ frequency hopping, stepped frequency or similar modulation types, measurement of the -10 dB minimum bandwidth specified in this paragraph shall be made with the frequency hop or step function disabled and with the transmitter operating continuously at a fundamental frequency following the provisions of §15.31(m).

The -10 dB bandwidth is based on measurement using a peak detector, a 1 MHz resolution bandwidth, and a video bandwidth greater than or equal to the resolution bandwidth.

**Test Equipment Used:**

Description:	Manufacturer:	Model:	Asset Number:	Cal Date:	Cal Due:
Antenna, Horn, <18 GHz	EMCO	3115	213061	04/30/2009	04/30/2010
Cable, 7 meters, 1-18GHz	Storm Products Co.	PR90-241-7MTR	ST-2	08/18/2009	08/18/2010
Preamplifier, 20 MHz to 18 GHz, 40 dB	A.H. Systems	PAM-0118	200108	04/07/2009	04/07/2010
Spectrum Analyzer, 20Hz-40GHz	Rohde & Schwarz	FSEK30	200062	10/19/2009	10/19/2010

**Results: The sample tested was found to Comply.**

**Plot:**

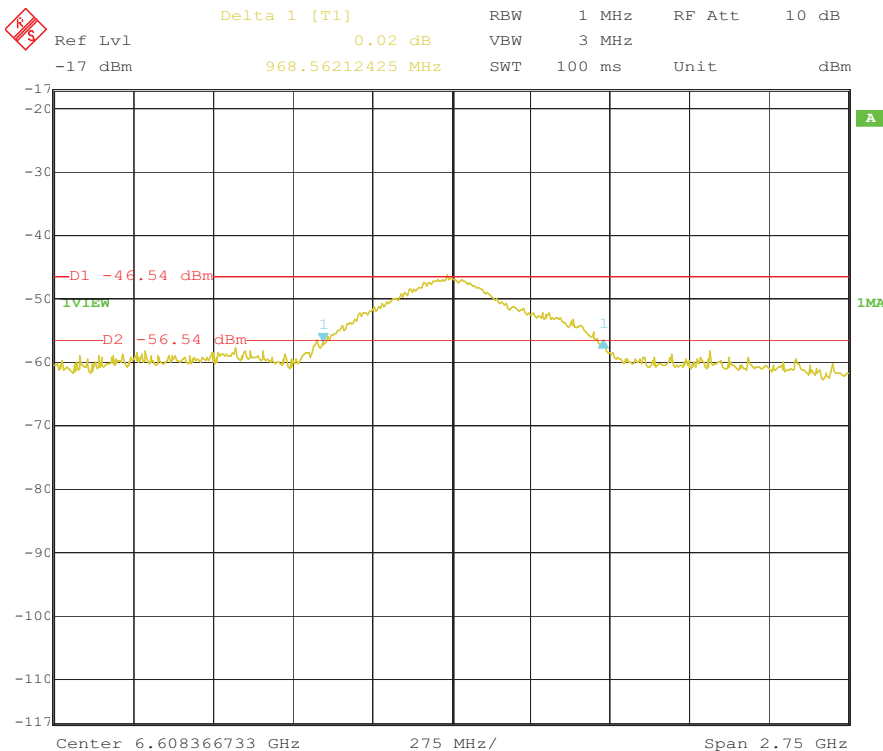

Date: 23.FEB.2010 08:47:43

-10dB down bandwidth

5.0 15.250(a) and 15.250(b): -10 dB Bandwidth requirements (Bandwidth)

Plot:

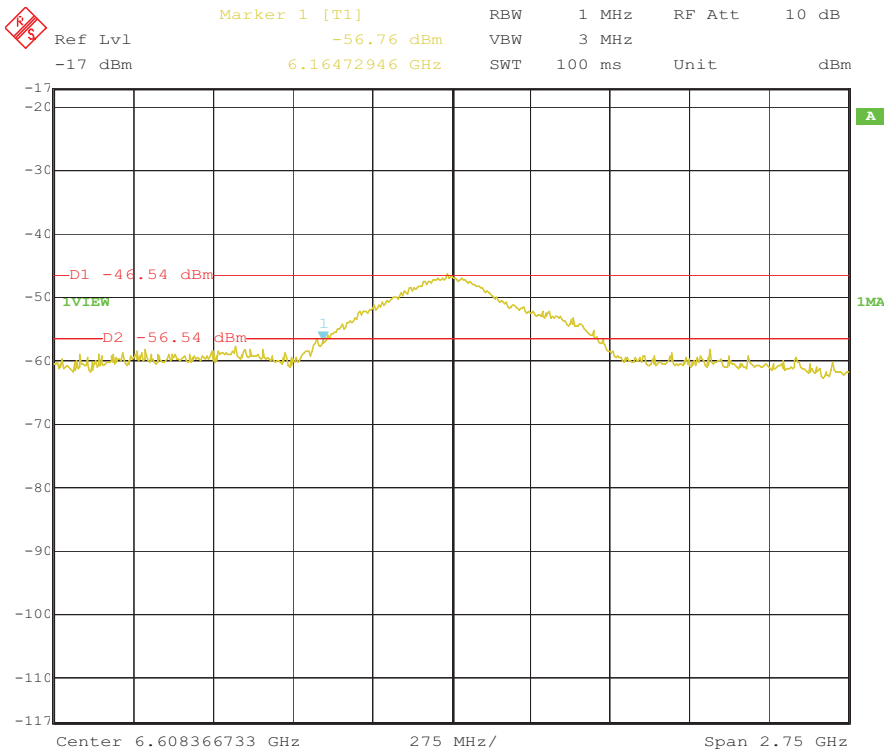

Date: 23.FEB.2010 08:49:09

Lower edge of bandwidth

5.0 15.250(a) and 15.250(b): -10 dB Bandwidth requirements (Bandwidth)

Plot:

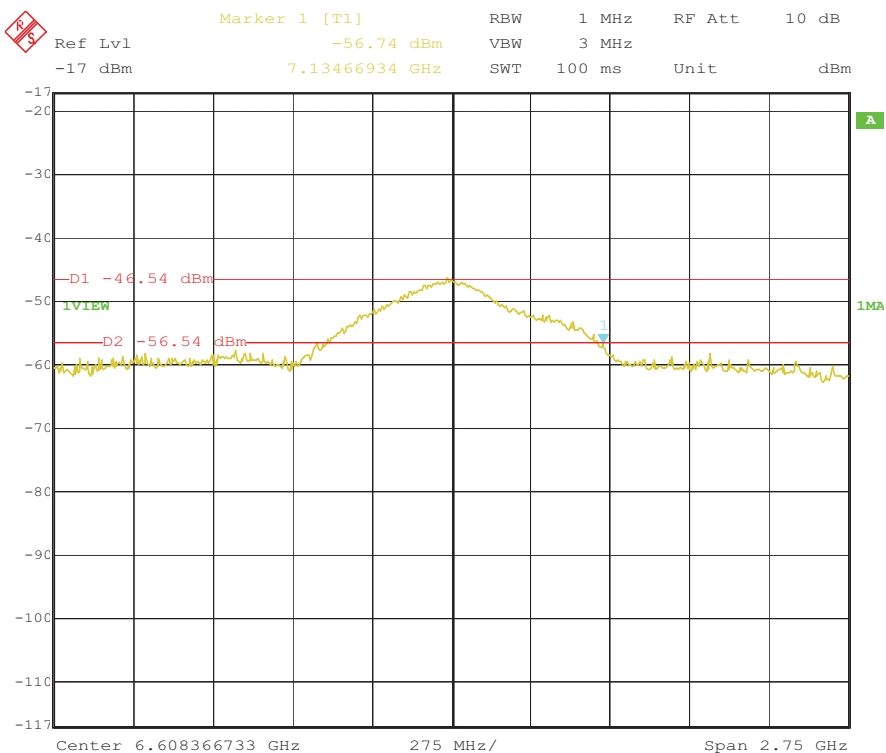

Date: 23.FEB.2010 08:50:01

Upper edge of bandwidth



**5.0 15.250(a) and 15.250(b): -10 dB Bandwidth requirements (Bandwidth)**

**Data:**

**Date:** 02/23/2010  
**Frequency Range (MHz):** 5925-7250  
**Input power:** 12Vdc

Standard: 15.250  
 Test Distance (m): 1  
 Limit: 15.250@1m  
 Modifications (y/n): n

Fundamental Frequency MHz	Measured Bandwidth MHz	Bandwidth Limits MHz	Bandwidth Margin MHz
6609.744	6164.729	5925	238.729 (1)
6609.744	7134.669	7250	115.331 (1)

Note: (1) The bandwidth is less than 80% of the frequency range so the frequency stability testing is not required.

Instrument Settings	
RBW (MHz):	1
VBW (MHz):	3
Span (MHz):	2750.000
Sweep time (ms):	100

**6.0 15.250(d)(1) Radiated power (EIRP) density (EIRP power density)****Method:**

(d) Emissions from a transmitter operating under this section shall not exceed the equivalent isotropically radiated power (EIRP) density levels:

(1) The radiated emissions above 960 MHz from a device operating under the provisions of this section shall not exceed the RMS average limits based on measurements using a 1 MHz resolution bandwidth.

Emissions from digital circuitry used to enable the operation of the transmitter may comply with the limits in §15.209 provided it can be clearly demonstrated that those emissions are due solely to emissions from digital circuitry contained within the transmitter and the emissions are not intended to be radiated from the transmitter's antenna. Emissions from associated digital devices, as defined in §15.3(k), e.g., emissions from digital circuitry used to control additional functions or capabilities other than the operation of the transmitter, are subject to the limits contained in subpart B of this part. Emissions from these digital circuits shall not be employed in determining the -10 dB bandwidth of the fundamental emission or the frequency at which the highest emission level occurs.

**Measurement procedures:**

All emissions at and below 960 MHz are based on measurements employing a CISPR quasi-peak detector. Unless otherwise specified, all RMS average emission levels specified in this section are to be measured utilizing a 1 MHz resolution bandwidth with a one millisecond dwell over each 1 MHz segment. The frequency span of the analyzer should equal the number of sampling bins times 1 MHz and the sweep rate of the analyzer should equal the number of sampling bins times one millisecond. The provision in §15.35(c) that allows emissions to be averaged over a 100 millisecond period does not apply to devices operating under this section. The video bandwidth of the measurement instrument shall not be less than the resolution bandwidth and trace averaging shall not be employed. The RMS average emission measurement is to be repeated over multiple sweeps with the analyzer set for maximum hold until the amplitude stabilizes.

**Test Equipment Used:**

Description:	Manufacturer:	Model:	Asset Number:	Cal Date:	Cal Due:
Antenna, Horn, <18 GHz	EMCO	3115	213061	04/30/2009	04/30/2010
Cable, 7 meters, 1-18GHz	Storm Products Co.	PR90-241-7MTR	ST-2	08/18/2009	08/18/2010
Excel spreadsheet for radiated emissions	Software	Excel - RE Worksh	SW004	12/09/2009	12/09/2010
Preamplifier, 20 MHz to 18 GHz, 40 dB	A.H. Systems	PAM-0118	200108	04/07/2009	04/07/2010
Spectrum Analyzer, 20Hz-40GHz	Rohde & Schwarz	FSEK30	200062	10/19/2009	10/19/2010
Tile - software profile for radiated and conducted emissions testing.	Software	Tile - Emissions	SW006	12/09/2009	12/09/2010

**Results: The sample tested was found to Comply.**

**6.0 15.250(d)(1) Radiated power (EIRP) density (EIRP power density)**

**Photo:**



Test Setup - Front view

6.0 15.250(d)(1) Radiated power (EIRP) density (EIRP power density)

Photo:

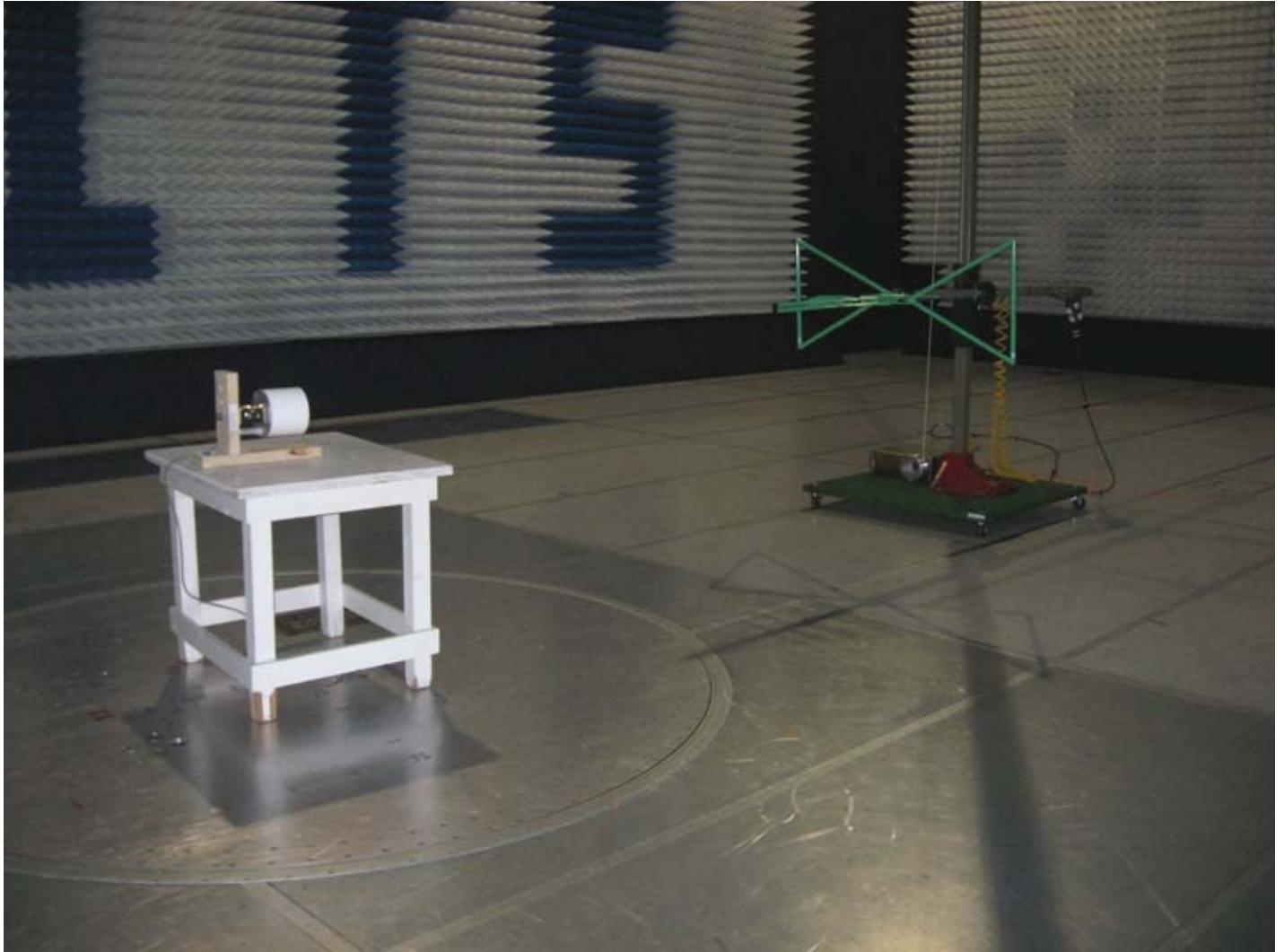

Test Setup - Rear view

6.0 15.250(d)(1) Radiated power (EIRP) density (EIRP power density)

Plot:

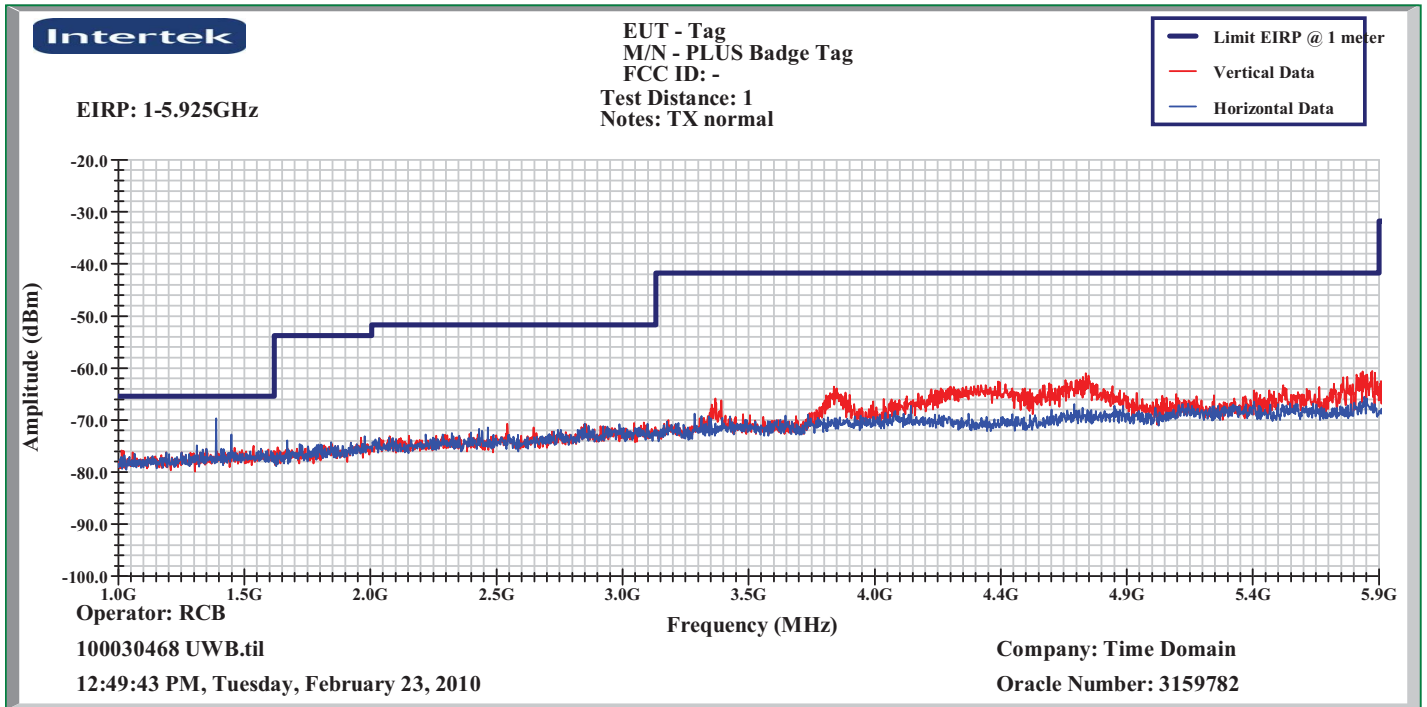

Peak Scan from 1.0 - 5.925GHz

6.0 15.250(d)(1) Radiated power (EIRP) density (EIRP power density)

Plot:

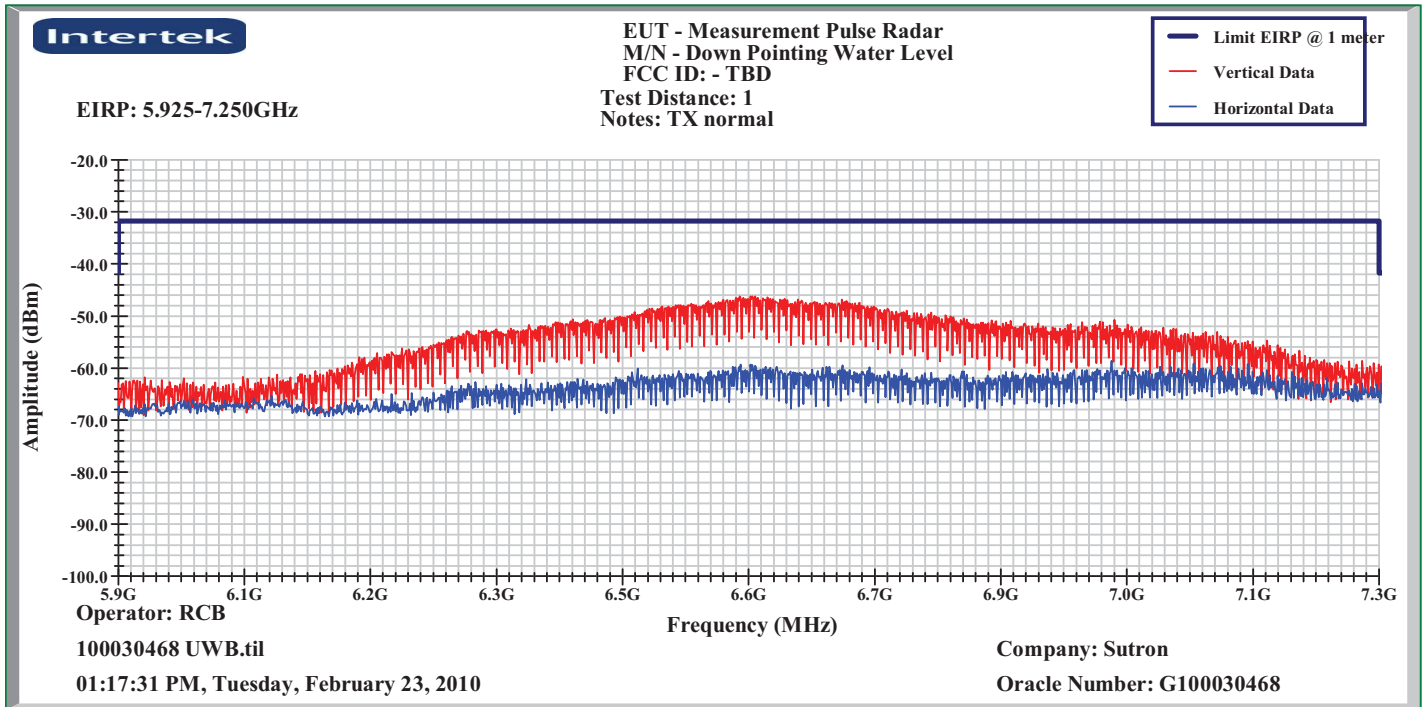

Peak Scan from 5.925 - 7.250GHz

6.0 15.250(d)(1) Radiated power (EIRP) density (EIRP power density)

Plot:

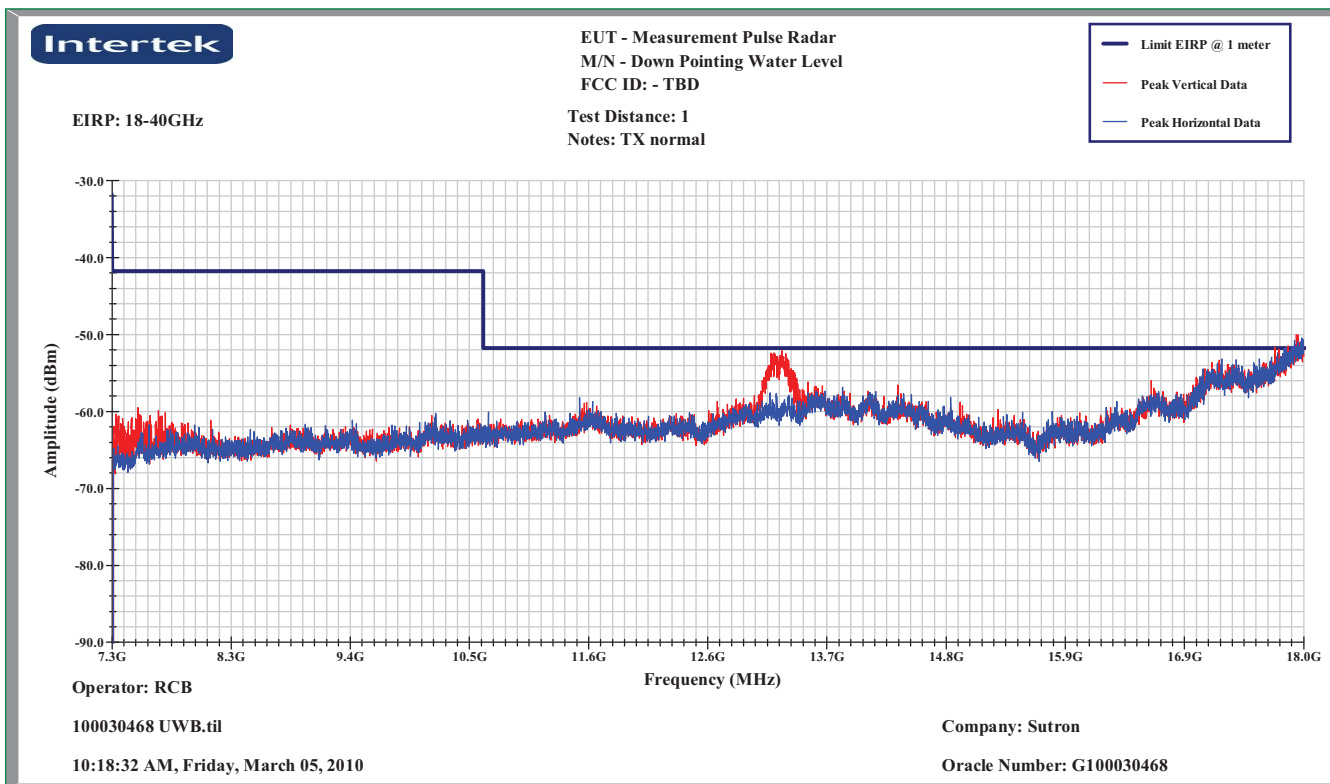

Peak Scan from 7.250 - 18.0GHz

6.0 15.250(d)(1) Radiated power (EIRP) density (EIRP power density)

Plot:

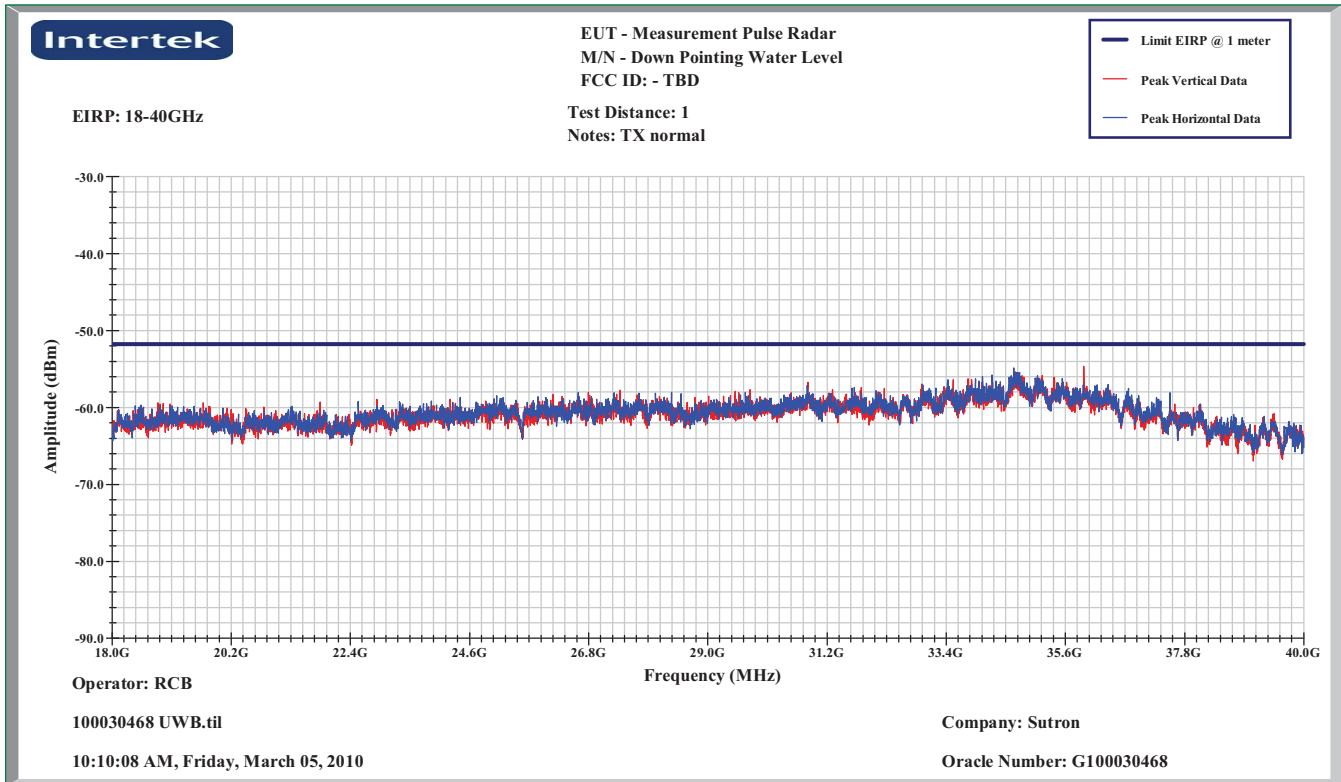

Peak Scan from 18.0 - 40.0GHz



## 6.0 15.250(d)(1) Radiated power (EIRP) density (EIRP power density)

## Data:

Client: Sutron

Receiver: HP 8546A

Model Number:

Antenna: EMCO 3115

Project Number: G100030468

Cables: ST-2

Tested By: RCB

Preamp: AH PAM-0118

Date: 02/23/2010

Frequency Range (MHz): 1000-40000

Test Distance (m): 1

Input power: 12Vdc

Limit: 15\_250d1-1m

Modifications for compliance (y/n): n

A	B	C	D	E	F	G	H	I	J
Ant. Pol. (V/H)	Frequency MHz	Reading dB(uV)	Antenna Factor dB(1/m)	Cable Loss dB	Pre-amp Factor dB	Net dB(uV/m)	1m Limit dB(uV/m)	Margin dB	Detectors / Bandwidths Det/RBW/VBW
V	6593.987	58.2	35.2	3.6	39.5	57.5	63.4	-5.9	RMS/1M/3M
V	13200.000	42.4	41.3	5.6	38.3	44.0	50.4	-6.4	RMS/1M/3M
<b>Calculations</b>		G=C+D+E-F		I=G-H					

## 7.0 Peak Power in a 50 MHz bandwidth (Peak Power per 50 MHz)

### Method:

(3) There is a limit on the peak level of the emissions contained within a 50 MHz bandwidth centered on the frequency at which the highest radiated emission occurs and this 50 MHz bandwidth must be contained within the 5925–7250 MHz band. The peak EIRP limit is 20 log (RBW/50) dBm where RBW is the resolution bandwidth in megahertz that is employed by the measurement instrument. RBW shall not be lower than 1 MHz or greater than 50 MHz. The video bandwidth of the measurement instrument shall not be less than RBW. If RBW is greater than 3 MHz, the application for certification filed with the Commission shall contain a detailed description of the test procedure, calibration of the test setup, and the instrumentation employed in the testing.

### Test Equipment Used:

Description:	Manufacturer:	Model:	Asset Number:	Cal Date:	Cal Due:
Antenna, Horn, <18 GHz	EMCO	3115	213061	04/30/2009	04/30/2010
Cable, 7 meters, 1-18GHz	Storm Products Co.	PR90-241-7MTR	ST-2	08/18/2009	08/18/2010
Preamplifier, 20 MHz to 18 GHz, 40 dB	A.H. Systems	PAM-0118	200108	04/07/2009	04/07/2010
Spectrum Analyzer, 20Hz-40GHz	Rohde & Schwarz	FSEK30	200062	10/19/2009	10/19/2010

**Results: The sample tested was found to Comply.**

### Plot:

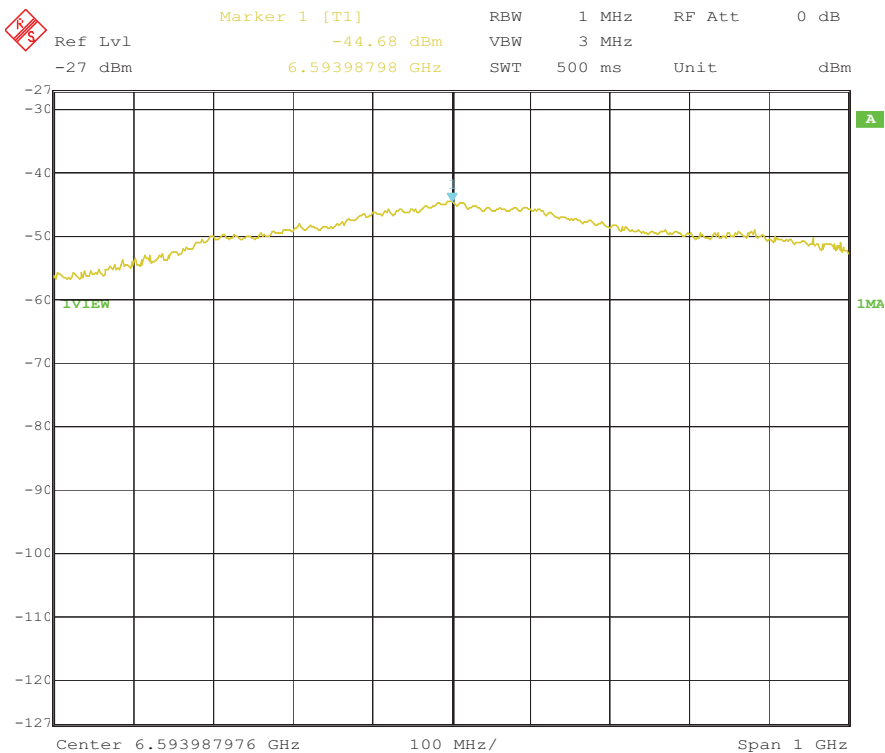

Date: 23.FEB.2010 13:16:22

Peak Power

**7.0 Peak Power in a 50 MHz bandwidth (Peak Power per 50 MHz)**

**Data:**

<b>Client:</b> Sutron	<b>Receiver:</b> R&S FSEK30
<b>Model Number:</b>	<b>Antenna:</b> EMCO 3115
<b>Project Number:</b> G100030468	<b>Cables:</b> ST2
<b>Tested By:</b> RCB	<b>Preamp:</b> PA-0118
<b>Date:</b> 02/23/2010	<b>Standard:</b> 15.250
<b>Frequency Range (MHz):</b> 5925-7250	<b>Test Distance (m):</b> 1
<b>Input power:</b> 12Vdc	<b>Limit:</b> 15.250 at 1 m

**Modifications for compliance (y/n):** n

A	B	C	D	E	F
<b>Ant.</b>		<b>EIRP</b>	<b>1 MHz</b>		<b>Detectors /</b>
<b>Pol.</b>	<b>Frequency</b>	<b>RBW: 1MHz</b>	<b>Limit</b>	<b>Margin</b>	<b>Bandwidths</b>
<b>(V/H)</b>	<b>MHz</b>	<b>dBm</b>	<b>dBm</b>	<b>dB</b>	<b>Det/RBW/VBW</b>
V	6609.744	-44.7	-34.0	-10.7	Pk / 1M / 3M
<b>Calculations</b>		<b>E=C-D</b>			

Limit =  $20 \cdot \log(\text{RBW}/50) = 20 \cdot \log(1/50) = -34 \text{ dBm}$

## 8.0 Radiated emissions below 960 MHz (Radiated Emissions (<960 MHz))

### Method:

Radiated emissions at or below 960 MHz shall not exceed the emission levels in §15.209.

Measurements in the frequency range of 30 MHz to 1000 MHz shall be performed with a quasi-peak detector instrument that meets the requirements of Section One of CISPR 16.

#### Bandwidths:

30 MHz to 1000 MHz: 120 kHz RBW and 1 MHz VBW

Measurements of the radiated field are made with the antenna located at a distance of 3 or 10 meters from the EUT. The limit applied to the measurement shall be appropriate for the test distance. The test distance shall be indicated in the results section.

The EUT shall be arranged and connected with cables terminated in accordance with the product specification.

Exploratory tests should be carried out while varying the cable positions to determine the maximum or near-maximum emission level. During manipulation, cables shall not be placed under or on top of the system test components unless such placement is required by the inherent equipment design.

The antenna shall be adjusted between 1m and 4m in height above the ground plane for maximum meter reading at each test frequency.

The antenna-to-EUT azimuth shall be varied during the measurement to find the maximum field-strength readings.

The antenna-to-EUT polarization (horizontal and vertical) shall be varied during the measurements to find the maximum field-strength readings.

If the EUT is intended for tabletop use, it shall be placed on a table whose top is 0.8m above the ground plane. The table shall be constructed of non-conductive materials. Its dimensions are at least 1m by 1.5m, but may be extended for larger EUT.

If EUT is floor standing, the EUT was placed on a horizontal metal ground plane and isolated from the ground plane by up to 12 mm of insulating material.

Equipment setup for radiated disturbance tests shall follow the guidelines of ANSI C63.4:2003.

### TEST SITE

The test site for radiated emissions is located at 1950 Evergreen Blvd, Suite 100, Duluth, Georgia 30096.

### MEASUREMENT UNCERTAINTY

Compliance of the product is based on the measured value. However, the measurement uncertainty is included for informational purposes. The values given are the measurement uncertainty values with an expanded uncertainty of k=2.

30 MHz to 1000 MHz at 3 meters: +/- 3.9 dB

30 MHz to 1000 MHz at 10 meters: +/- 3.6 dB

1 GHz to 18 GHz at 3 meters: +/- 4.2 dB

### Test Equipment Used:

Description:	Manufacturer:	Model:	Asset Number:	Cal Date:	Cal Due:
Antenna, BiLog, 20-2000MHz	Chase	CBL6112B	211386	10/02/2009	10/02/2010
Cable E01, <18GHz	Pasternack	RG214/U	E01	05/04/2009	05/04/2010
Cable E201, 18 GHz, N, 3m	Megaphase	TM18 NKNK 118	E201	02/02/2010	02/02/2011
Cable MP3, 18 GHz, N, 10m	Megaphase	G919-NKNK-394	MP3	05/04/2009	05/04/2010
Cable, N-N 3 meters, 18GHz	Megaphase	TM18 NKNK 118	E203	05/12/2009	05/12/2010
EMI Receiver	Hewlett Packard	8546A	213109	10/06/2009	10/06/2010
EMI Receiver, Preselector section	Hewlett Packard	85460A	213108	10/06/2009	10/06/2010
Excel spreadsheet for radiated emissions	Software	Excel - RE Worksh	SW004	12/09/2009	12/09/2010
Preamplifier, 10 MHz to 2000 MHz, 27 dB gain	Mini-Circuits	ZKL-2	200074	09/17/2009	09/17/2010
Spectrum Analyzer, 20Hz-40GHz	Rohde & Schwarz	FSEK30	200062	10/19/2009	10/19/2010
Tile - software profile for radiated and conducted emissions testing.	Software	Tile - Emissions	SW006	12/09/2009	12/09/2010

**Results: The sample tested was found to Comply.**

8.0 Radiated emissions below 960 MHz (Radiated Emissions (<960 MHz))

Photo:



Test Setup - Front view

**8.0 Radiated emissions below 960 MHz (Radiated Emissions (<960 MHz))**

**Photo:**



Test Setup - Rear view

8.0 Radiated emissions below 960 MHz (Radiated Emissions (<960 MHz))

Plot:

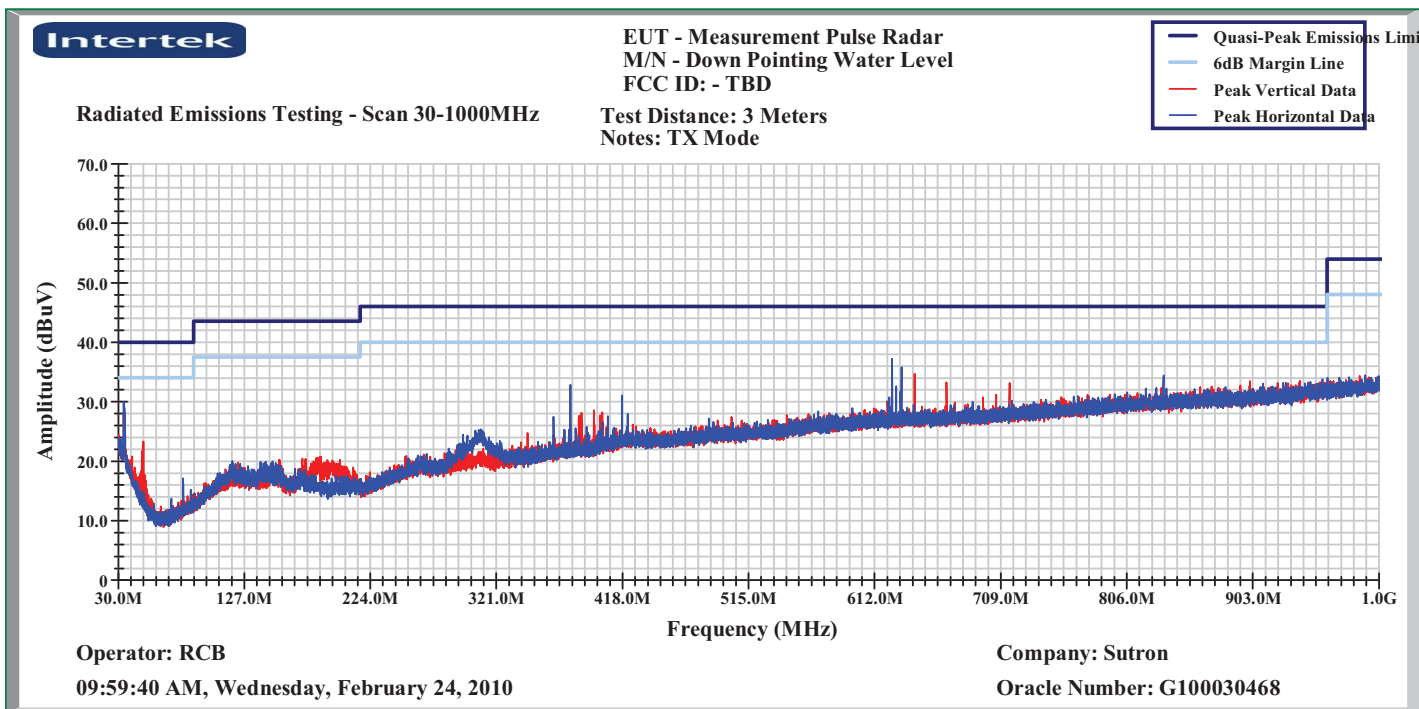

Radiated Emissions to FCC 15.209 limits

**8.0 Radiated emissions below 960 MHz (Radiated Emissions (<960 MHz))**

**Data:**

**Client:** Sutron

**Receiver:** HP 8546A

**Model Number:**

**Antenna:** Chase 2622

**Project Number:** G100030468

**Cables:** E01+MP3+E201+E203

**Tested By:** RCB

**Preamp:** ZKL-2 D052005

**Date:** 02/23/2010

**Frequency Range (MHz):** 30-1000

**Test Distance (m):** 3

**Input power:** 12Vdc battery

**Limit:** FCC15 Class B-3m

**Modifications for compliance (y/n):** n

A	B	C	D	E	F	G	H	I	J
Ant. Pol. (V/H)	Frequency MHz	Reading dB(uV)	Antenna Factor dB(1/m)	Cable Loss dB	Pre-amp Factor dB	Net dB(uV/m)	3m Limit dB(uV/m)	Margin dB	Detectors / Bandwidths Det/RBW/VBW
H	34.650	35.7	16.0	1.1	27.7	25.2	40.0	-14.8	QP/120k/300k
H	314.980	33.0	13.7	3.7	27.7	22.7	46.0	-23.3	QP/120k/300k
H	379.980	38.8	15.5	4.2	27.6	30.9	46.0	-15.1	QP/120k/300k
H	625.088	35.4	19.2	5.4	27.4	32.6	46.0	-13.4	QP/120k/300k
H	625.300	36.3	19.2	5.4	27.4	33.4	46.0	-12.6	QP/120k/300k
H	660.110	29.0	19.2	5.6	27.4	26.4	46.0	-19.6	QP/120k/300k
<b>Calculations</b>		G=C+D+E-F		I=G-H					



**9.0 15.250(d)(2) Radiated power (EIRP) density in GPS receive bands (EIRP power density (GPS))****Method:**

(d) Emissions from a transmitter operating under this section shall not exceed the equivalent isotropically radiated power (EIRP) density levels:

Transmitters operating under the provisions of this section shall not exceed the RMS average limits when measured using a resolution bandwidth of no less than 1 kHz.

Emissions from digital circuitry used to enable the operation of the transmitter may comply with the limits in §15.209 provided it can be clearly demonstrated that those emissions are due solely to emissions from digital circuitry contained within the transmitter and the emissions are not intended to be radiated from the transmitter's antenna. Emissions from associated digital devices, as defined in §15.3(k), e.g., emissions from digital circuitry used to control additional functions or capabilities other than the operation of the transmitter, are subject to the limits contained in subpart B of this part. Emissions from these digital circuits shall not be employed in determining the -10 dB bandwidth of the fundamental emission or the frequency at which the highest emission level occurs.

**Measurement procedures:**

All emissions at and below 960 MHz are based on measurements employing a CISPR quasi-peak detector. Unless otherwise specified, all RMS average emission levels specified in this section are to be measured utilizing a resolution bandwidth greater than with a one millisecond dwell over each segment (equal to the RBW). The frequency span of the analyzer should equal the number of sampling bins times RBW and the sweep rate of the analyzer should equal the number of sampling bins times one millisecond. The provision in §15.35(c) that allows emissions to be averaged over a 100 millisecond period does not apply to devices operating under this section. The video bandwidth of the measurement instrument shall not be less than the resolution bandwidth and trace averaging shall not be employed. The RMS average emission measurement is to be repeated over multiple sweeps with the analyzer set for maximum hold until the amplitude stabilizes.

**Test Equipment Used:**

Description:	Manufacturer:	Model:	Asset Number:	Cal Date:	Cal Due:
Antenna, Horn, <18 GHz	EMCO	3115	213061	04/30/2009	04/30/2010
Cable, 7 meters, 1-18GHz	Storm Products Co.	PR90-241-7MTR	ST-2	08/18/2009	08/18/2010
Preamplifier, 20 MHz to 18 GHz, 40 dB	A.H. Systems	PAM-0118	200108	04/07/2009	04/07/2010
Spectrum Analyzer, 20Hz-40GHz	Rohde & Schwarz	FSEK30	200062	10/19/2009	10/19/2010

**Results: The sample tested was found to Comply.**

9.0 15.250(d)(2) Radiated power (EIRP) density in GPS receive bands (EIRP power density (GPS))

Plot:

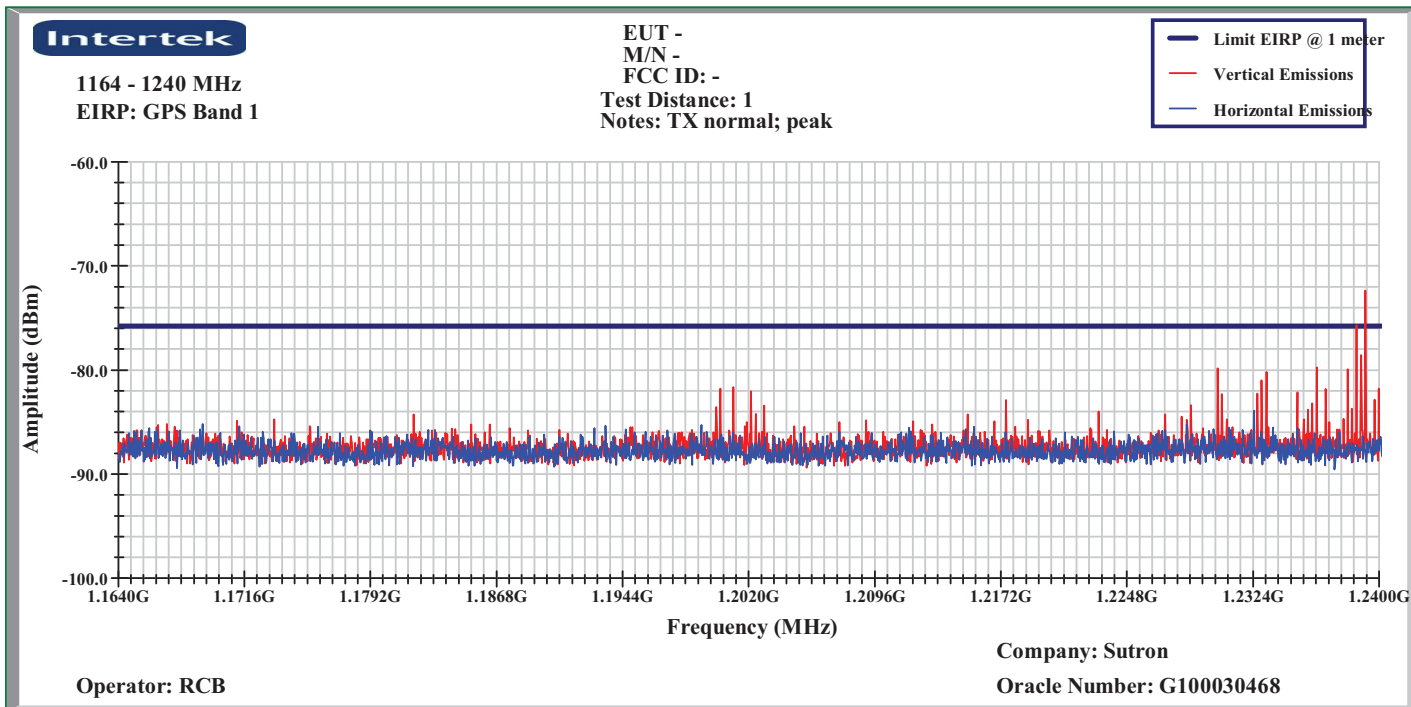

GPS Band#1

9.0 15.250(d)(2) Radiated power (EIRP) density in GPS receive bands (EIRP power density (GPS))

Plot:

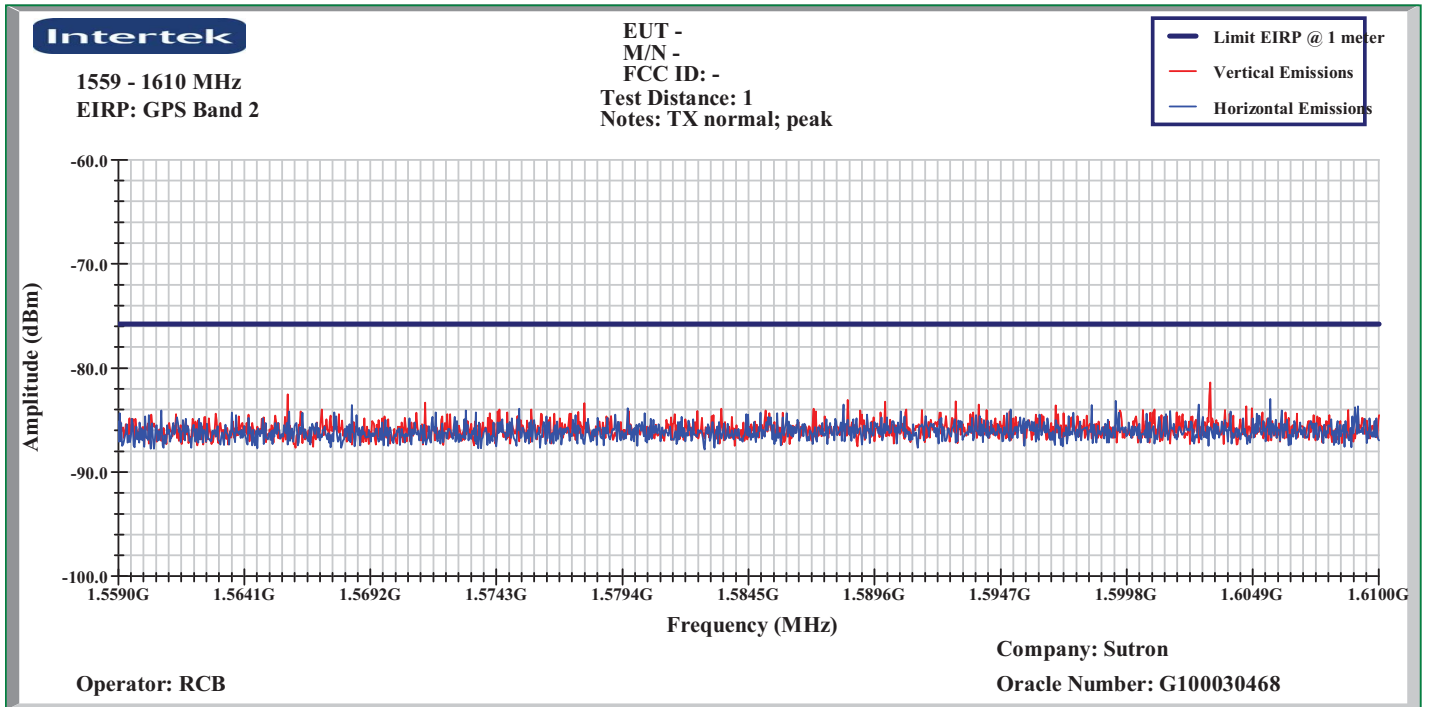

GPS Band#2

**9.0 15.250(d)(2) Radiated power (EIRP) density in GPS receive bands (EIRP power density (GPS))**

**Data:**

**Client:** Sutron

**Receiver:** HP 8546A

**Model Number:** Down pointing water level

**Antenna:** EMCO 3115

**Project Number:** G100030468

**Cables:** ST-2

**Tested By:** RCB

**Preamp:** AH PAM-0118

**Date:** 02/23/2010

**Frequency Range (MHz):** 1164 - 1610

**Test Distance (m):** 1

**Input power:** 12Vdc

**Limit:** 15\_250d1-1m

**Modifications for compliance (y/n):** n

A	B	C	D	E	F	G	H	I	J
<b>Ant. Pol. (V/H)</b>	<b>Frequency MHz</b>	<b>Reading dB(uV)</b>	<b>Antenna Factor dB(1/m)</b>	<b>Cable Loss dB</b>	<b>Pre-amp Factor dB</b>	<b>Net dB(uV/m)</b>	<b>1m Limit dB(uV/m)</b>	<b>Margin dB</b>	<b>Detectors / Bandwidths Det/RBW/VBW</b>
V	1190.000	7.4	24.8	1.4	40.4	-6.8	29.4	-36.2	RMS/1k/30k
<b>Calculations</b>		G=C+D+E-F		I=G-H					