



Engineering Solutions & Electromagnetic Compatibility Services

**FCC & Industry Canada Limited Modular Approval
Certification Application Report**

Test Lab: Rhein Tech Laboratories, Inc. Tel: 703-689-0368 360 Herndon Parkway Fax: 703-689-2056 Suite 1400 www.rheintech.com Herndon, VA 20170 E-Mail: atcbinfo@rheintech.com		Applicant: Sutron Corporation Tel: (703) 406-2800 22400 Davis Drive Sterling, VA 20164	
FCC/IC ID	HDB-6461-1311-1/ 1088A-646113111	Test Report Date	September 11, 2014
Platform	N/A	RTL Work Order #	2014075
Model #	6461-1311-1	RTL Quote #	QRTL14-075A
American National Standard Institute	ANSI C63.4-2003: Methods of Measurement of Radio-Noise Emissions from Low-Voltage Electrical and Electronic Equipment in the Range of 9 kHz to 40 GHz		
FCC Classification	DTS – Part 15 Digital Transmission System		
FCC Rule Part(s)/ Guidance	FCC Rules Part 15.247: Operation within the bands 920-928 MHz, 2400-2483.5 MHz and 5725-5850 MHz Direct Sequence System (10-01-13)		
Industry Canada	RSS-210 Issue 8: Low Power License-Exempt Communications Devices RSS-Gen: Issue 3; 2010 General Requirements and Information for the Certification of Radio Apparatus		
Digital Interface Information	Digital Interface was found to be compliant		
Frequency Range (MHz)	Output Power (W)	Frequency Tolerance	Emission Designator
2415 – 2460	0.246	N/A	1M60FXD

I, the undersigned, hereby declare that the equipment tested and referenced in this report conforms to the identified standard(s) as described in this test report. No modifications were made to the equipment during testing in order to achieve compliance with these standards. Furthermore, there was no deviation from, additions to, or exclusions from, the applicable parts of FCC Part 2, FCC Part 15, RSS-210, and ANSI C63.4.

Signature: 

Date: September 11, 2014

Typed/Printed Name: Desmond A. Fraser

Position: President

This report may not be reproduced, except in full, without the written approval of Rhein Tech Laboratories, Inc. and Sutron Corp. The test results relate only to the item(s) tested.

These tests are accredited and meet the requirements of ISO/IEC 17025 as verified by ANSI-ASQ National Accreditation Board/ACLASS. Refer to certificate and scope of accreditation AT-1445.

Table of Contents

1	General Information	5
1.1	Scope	5
1.2	Description of EUT	5
1.3	Test Facility	5
1.4	Related Submittal(s)/Grant(s)	5
1.5	Modifications	5
2	Test Information	6
2.1	Description of Test Modes	6
2.2	Exercising the EUT	6
2.3	Test Result Summary	6
2.4	Test System Details	7
2.5	Configuration of Tested System	7
3	Peak Output Power – FCC §15.247(b)(1); RSS-210 §A8.4(4)	8
3.1	Power Output Test Procedure	8
3.2	Power Output Test Data	8
4	Compliance with the Band Edge – FCC §15.247(d); RSS-210 §2.2	9
4.1	Band Edge Test Procedure	9
4.2	Restricted Band Edge Test Results	10
4.2.1	Calculation of Lower Band Edge	10
4.2.2	Calculation of Upper Band Edge	11
5	Antenna Conducted Spurious Emissions – FCC §15.247(d); RSS-Gen	12
5.1.1	Antenna Conducted Spurious Emissions Test Procedure	12
5.2	Antenna Conducted Spurious Emissions Test Results	12
6	Power Spectral Density – FCC §15.247(e); RSS-210 §A8.2	15
6.1	Power Spectral Density Test Procedure	15
6.2	Power Spectral Density Test Data	15
7	Radiated Emissions – FCC §15.209; RSS-210 §A8.5	19
7.1	Limits of Radiated Emissions Measurement	19
7.2	Radiated Emissions Measurement Test Procedure	19
7.3	Radiated Emissions Harmonics/Spurious Test Data	21
8	AC Conducted Emissions - FCC §15.207; RSS-Gen §7.2.4: Conducted Limits	23
8.1	Conducted Limits - §15.207	23
8.2	Conducted Line Emissions Test Procedure	23
8.3	Conducted Line Emission Test Description	23
8.4	Conducted Line Emission Test Data	24
9	6 dB Bandwidth – FCC §15.247(a)(2); RSS-210 §A8.2	28
9.1	6 db Bandwidth Test Procedure – Minimum 6 dB Bandwidth	28
9.2	6 dB Modulated Bandwidth Test Data	28
10	Conclusion	32

Figure Index

Figure 2-1: Configuration of Tested System.....	7
---	---

Table Index

Table 2-1: Channels Tested	6
Table 2-2: Test Result Summary – FCC Part 15, Subpart C (Section 15.247).....	6
Table 2-3: Equipment Under Test	7
Table 3-1: Power Output Test Equipment	8
Table 3-2: Power Output Test Data.....	8
Table 4-1: Band Edge Test Equipment	9
Table 5-1: Antenna Conducted Spurious Emissions Test Equipment	12
Table 6-1: Power Spectral Density Test Equipment	15
Table 6-2: Power Spectral Density Test Data – 802.11b	15
Table 7-1: Radiated Emissions Test Equipment	20
Table 7-2: Radiated Emissions Harmonics/Spurious - 2415 MHz – Peak Detector	21
Table 7-3: Radiated Emissions Harmonics/Spurious - 2415 MHz – Average Detector	21
Table 7-4: Radiated Emissions Harmonics/Spurious - 2435 MHz – Peak Detector	21
Table 7-5: Radiated Emissions Harmonics/Spurious - 2435 MHz – Average Detector	21
Table 7-6: Radiated Emissions Harmonics/Spurious - 2460 MHz – Peak Detector	22
Table 7-7: Radiated Emissions Harmonics/Spurious - 2460 MHz – Average Detector	22
Table 8-1: Conducted Line Emissions Test Equipment	23
Table 9-1: 6 dB Bandwidth Test Equipment.....	28
Table 9-2: 6 dB Bandwidth Test Data	28

Plot Index

Plot 4-1: Lower Band Edge - 2415 MHz	10
Plot 4-2: Upper Band Edge - 2460 MHz	11
Plot 5-1: Spurious Emissions at Antenna Terminals – 2415 MHz.....	12
Plot 5-2: Spurious Emissions at Antenna Terminals – 2435 MHz.....	13
Plot 5-3: Spurious Emissions at Antenna Terminals – 2460 MHz.....	14
Plot 6-1: Power Spectral Density - 2415 MHz	16
Plot 6-2: Power Spectral Density - 2435 MHz	17
Plot 6-3: Power Spectral Density - 2460 MHz	18
Plot 8-1: Conducted Emissions (Phase Side) (Standby Mode).....	24
Plot 8-2: Conducted Emissions (Neutral Side) (Standby Mode)	25
Plot 8-3: Conducted Emissions (Phase Side) (Transmit Mode, Center Channel 6).....	26
Plot 8-4: Conducted Emissions (Neutral Side) (Transmit Mode, Center Channel 6)	27
Plot 9-1: 6 dB Bandwidth - 2415 MHz	29
Plot 9-2: 6 dB Bandwidth - 2435 MHz	30
Plot 9-3: 6 dB Bandwidth - 2460 MHz	31

Appendix Index

Appendix A:	FCC Part 1.1307, 1.1310, 2.1091, 2.1093; IC RSS-Gen: RF Exposure - MPE.....	33
Appendix B:	Agency Authorization Letter	34
Appendix C:	FCC Confidentiality Request Letter.....	35
Appendix D:	FCC Limited Modular Approval Criteria	36
Appendix E:	IC Letters.....	37
Appendix F:	IC Confidentiality Request Letter	38
Appendix G:	Canadian Based Representative Attestation Letter	39
Appendix H:	IC Limited Modular Approval Criteria	40
Appendix I:	ID Label and Label Location	41
Appendix J:	Technical Operational Description	43
Appendix K:	Schematics.....	44
Appendix L:	Block Diagram	45
Appendix M:	Manual.....	46
Appendix N:	Test Photographs	47
Appendix O:	External Photographs	51
Appendix P:	Internal Photographs	55

Photograph Index

Photograph 1:	ID Label on EUT Top	41
Photograph 2:	Sample Host Label Location	42
Photograph 3:	Radiated Testing – Front View.....	47
Photograph 4:	Radiated Testing – Rear View	48
Photograph 5:	Conducted AC Testing – Front View.....	49
Photograph 6:	Conducted AC Testing – Rear View	50
Photograph 7:	EUT Top View with Shield.....	51
Photograph 8:	EUT Top View without Shield.....	52
Photograph 9:	EUT Bottom View	53
Photograph 10:	Sample Host	54
Photograph 11:	EUT Top View with Shield	55
Photograph 12:	EUT Top View without Shield	56
Photograph 13:	EUT Bottom View	57

1 General Information

1.1 Scope

This is an original certification application request for the Sutron Corp. 802.15.4 transceiver, Model # 6461-1311-1

Applicable Standards:

- FCC Rules Part 15.247: Frequency Hopping, Direct Spread Spectrum and Hybrid Systems that are in operation within the bands of 902-928 MHz, 2400-2483.5 MHz and 5725-5850 MHz.
- Industry Canada RSS-210: Low Power License-Exempt Communications Devices

1.2 Description of EUT

Equipment Under Test	802.15.4 Transceiver
Model #	6461-1311-1
Power Supply	8-15 VDC
Modulation Type	DSSS
Frequency Range	2415–2460 MHz
Antenna Connector Type	U.FL on PCB, reverse SMA at antenna
Antenna Type	3.2 dBi; ½ wave whip

1.3 Test Facility

The open area test site and conducted measurement facility used to collect the radiated data is located at 360 Herndon Parkway, Suite 1400, Herndon, Virginia 20170. This site has been fully described in a report and approved by the Federal Communications Commission to perform AC line conducted and radiated emissions testing (ANSI C63.4-2003).

1.4 Related Submittal(s)/Grant(s)

This is an original **LIMITED MODULAR APPROVAL** certification application for Sutron Corporation 802.15.4 transmitter, Model # 6461-1311-1, FCC ID: HDB-6461-1311-1, IC: 1088A-646113111.

1.5 Modifications

No modifications were made to the equipment during testing in order to achieve compliance with these standards.

2 Test Information

2.1 Description of Test Modes

In accordance with FCC 15.31(m), and because the EUT utilizes an operating band greater than 10 MHz, the following frequencies were tested:

Table 2-1: Channels Tested

Channel	Frequency
Low	2415
Middle	2435
High	2460

2.2 Exercising the EUT

The EUT was supplied with test firmware programmed with a high, mid, and low channel for testing. The EUT was tested in all three orthogonal planes in order to determine worst-case emissions. The EUT was provided with software to continuously transmit during testing. The carrier was also checked to verify that information was being transmitted.

2.3 Test Result Summary

Table 2-2: Test Result Summary – FCC Part 15, Subpart C (Section 15.247)

Standard	Test	Pass/Fail or N/A
FCC 15.207	AC Power Conducted Emissions	Pass
FCC 15.209	Radiated Emissions	Pass
FCC 15.247(a)(2)	6 dB Bandwidth	Pass
FCC 15.247(b)	Maximum Peak Power Output	Pass
FCC 15.247(d)	Antenna Conducted Spurious Emissions	Pass
FCC 15.247(e)	Power Spectral Density	Pass
FCC 15.247(d)	Band Edge Measurement	Pass

2.4 Test System Details

The test samples were received on August 28, 2014. The FCC identifiers for all applicable equipment, plus descriptions of all cables used in the tested system, are identified in the following table.

Table 2-3: Equipment Under Test

Part	Manufacturer	Model	Serial Number	FCC ID	Cable Description	RTL Bar Code
802.15.4 Transceiver Module	Sutron Corporation	6461-1311-1	N/A	HDB-6461-1311-1	N/A	20464
3.2 dBi Omni Antenna	Linx	ANT-2.4-CW-HW	N/A	N/A	N/A	20463

2.5 Configuration of Tested System

Figure 2-1: Configuration of Tested System

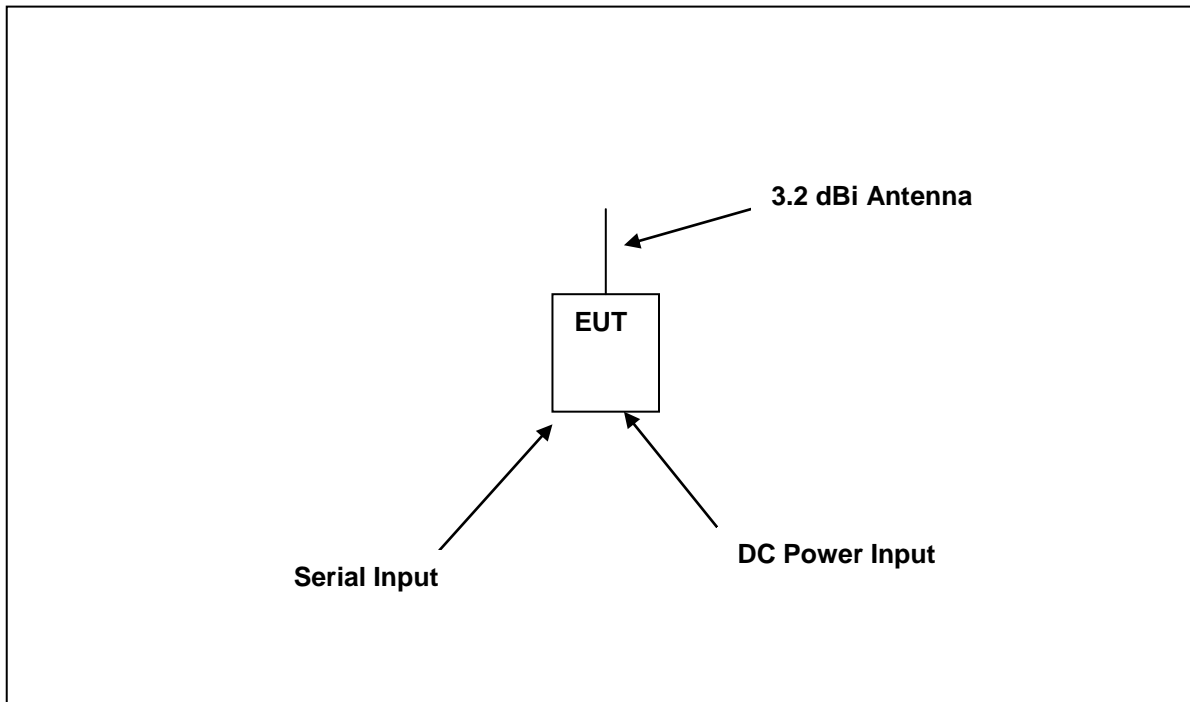

3 Peak Output Power – FCC §15.247(b)(1); RSS-210 §A8.4(4)

3.1 Power Output Test Procedure

A radiated power measurement of the EUT was taken using a Rhode & Schwarz FSU Spectrum Analyzer since no antenna test port was available.

Table 3-1: Power Output Test Equipment

RTL Asset #	Manufacturer	Model	Part Type	Serial Number	Calibration Due Date
901581	Rohde & Schwarz	1166.1660.50	Spectrum Analyzer	2001006	11/13/14

3.2 Power Output Test Data

Table 3-2: Power Output Test Data

Frequency (MHz)	Peak Power Conducted Output (dBm)
2415	23.9
2435	23.6
2460	23.2

Test Personnel:

Daniel W. Baltzell
Test Engineer



Signature

September 2, 2014
Date of Test

4 Compliance with the Band Edge – FCC §15.247(d); RSS-210 §2.2

4.1 Band Edge Test Procedure

The transmitter output was connected to its appropriate antenna. Peak (1 MHz RBW/VBW) and average (1 MHz RBW/10 Hz VBW) radiated measurements were taken with a suitable span to encompass the peak of the fundamental. A delta measurement was performed from the highest peak in the restricted band to the peak of the fundamental, and subtracted from the field strength; the result was compared to the limit in the restricted band (54 dBuV/m).

Table 4-1: Band Edge Test Equipment

RTL Asset #	Manufacturer	Model	Part Type	Serial Number	Calibration Due Date
901581	Rohde & Schwarz	1166.1660.50	Spectrum Analyzer	2001006	11/13/14
900878	Rhein Tech Laboratories	AM3-1197-0005	3 meter antenna mast, polarizing	Outdoor Range 1	Not Required
901242	Rhein Tech Laboratories	WRT-000-0003	Wood Rotating Table	N/A	Not Required
900772	EMCO	3161-02	Horn Antenna (2-4 GHz)	9804-1044	4/20/15
901592	Insulated Wire Inc.	KPS-1503-3600-KPR	SMK RF Cables 20'	NA	8/27/15
901593	Insulated Wire Inc.	KPS-1503-360-KPR	SMK RF Cables 36"	NA	8/27/15
900932	Hewlett Packard	8449B OPT H02	Preamplifier (1-26.5 GHz)	3008A00505	8/27/15

4.2 Restricted Band Edge Test Results

4.2.1 Calculation of Lower Band Edge

114.5 dBuV/m is the field strength measurement, from which the delta measurement of 67.4 dB is subtracted (reference plots), resulting in a level of 47.1 dBuV/m. This level has a margin of 6.9 dB below the limit of 54 dBuV/m.

Calculation: $114.5 \text{ dBuV/m} - 67.4 \text{ dB} - 54 \text{ dBuV/m} = -6.9 \text{ dB}$

Peak Field Strength of Lower Band Edge (1 MHz RBW/3 MHz VBW, Pk Det.) = 117.3 dBuV/m
 Average Field Strength of Lower Band Edge (1 MHz RBW/3 MHz VBW, Av Det.) = 114.5 dBuV/m
 Delta measurement 67.4 dB

Plot 4-1: Lower Band Edge - 2415 MHz

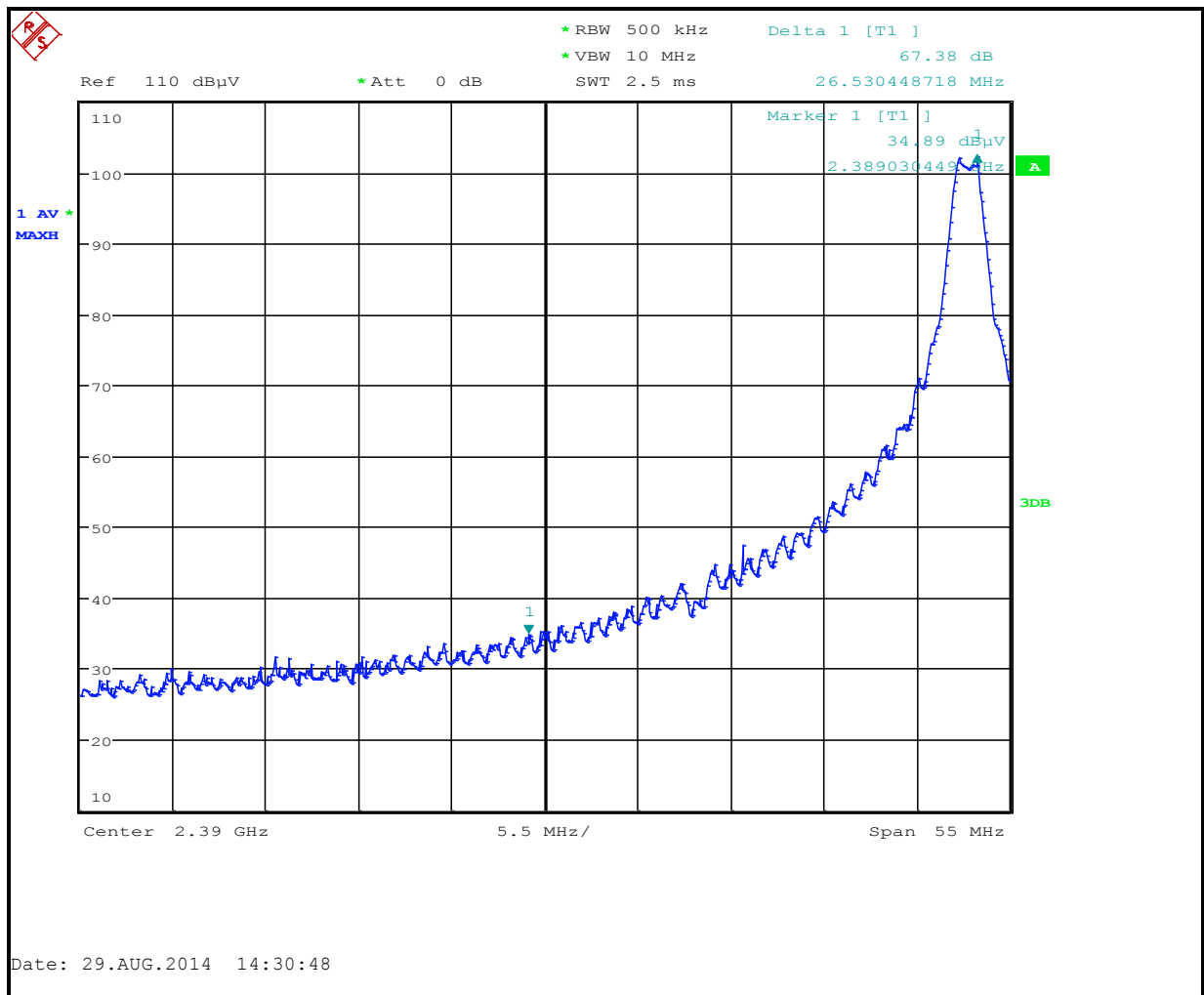

4.2.2 Calculation of Upper Band Edge

114.6 dBuV/m is the field strength measurement, from which the delta measurement of 66.9 dB is subtracted (reference plots), resulting in a level of 47.7 dBuV/m. This level has a margin of 6.3 dB below the limit of 54 dBuV/m.

Calculation: $114.6 \text{ dBuV/m} - 66.9 \text{ dB} - 54 \text{ dBuV/m} = -6.3 \text{ dB}$

Peak Field Strength of Upper Band Edge (1 MHz RBW/3 MHz VBW, Pk. Det.) = 117.3 dBuV/m
 Average Field Strength of Upper Band Edge (1 MHz RBW/3 MHz VBW, Av Det.) = 114.6 dBuV/m
 Delta measurement = 66.9 dB

Plot 4-2: Upper Band Edge - 2460 MHz

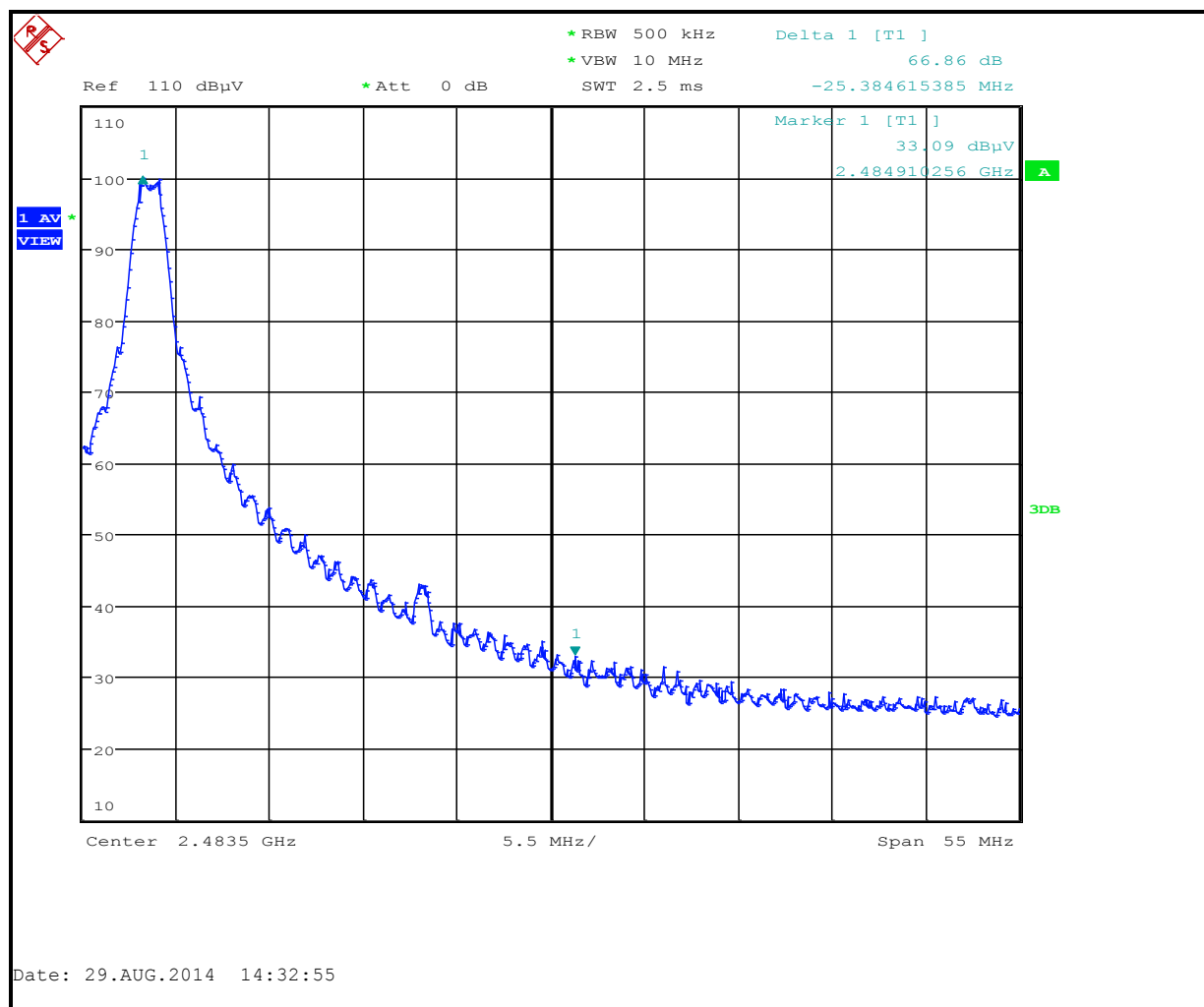

Test Personnel:

Daniel W. Baltzell
 Test Engineer

Daniel W. Baltzell
 Signature

August 29, 2014
 Date of Test

5 Antenna Conducted Spurious Emissions – FCC §15.247(d); RSS-Gen

5.1.1 Antenna Conducted Spurious Emissions Test Procedure

Antenna spurious emissions per FCC 15.247(d) were measured from the EUT antenna port using a 50 ohm spectrum analyzer with the resolution and video bandwidth set at 100 kHz. The modulated carrier was identified at the following frequencies: 2415 MHz, 2435 MHz and 2460 MHz.

Table 5-1: Antenna Conducted Spurious Emissions Test Equipment

RTL Asset #	Manufacturer	Model	Part Type	Serial Number	Calibration Due Date
901581	Rohde & Schwarz	1166.1660.50	Spectrum Analyzer	2001006	11/13/14

5.2 Antenna Conducted Spurious Emissions Test Results

Plot 5-1: Spurious Emissions at Antenna Terminals – 2415 MHz

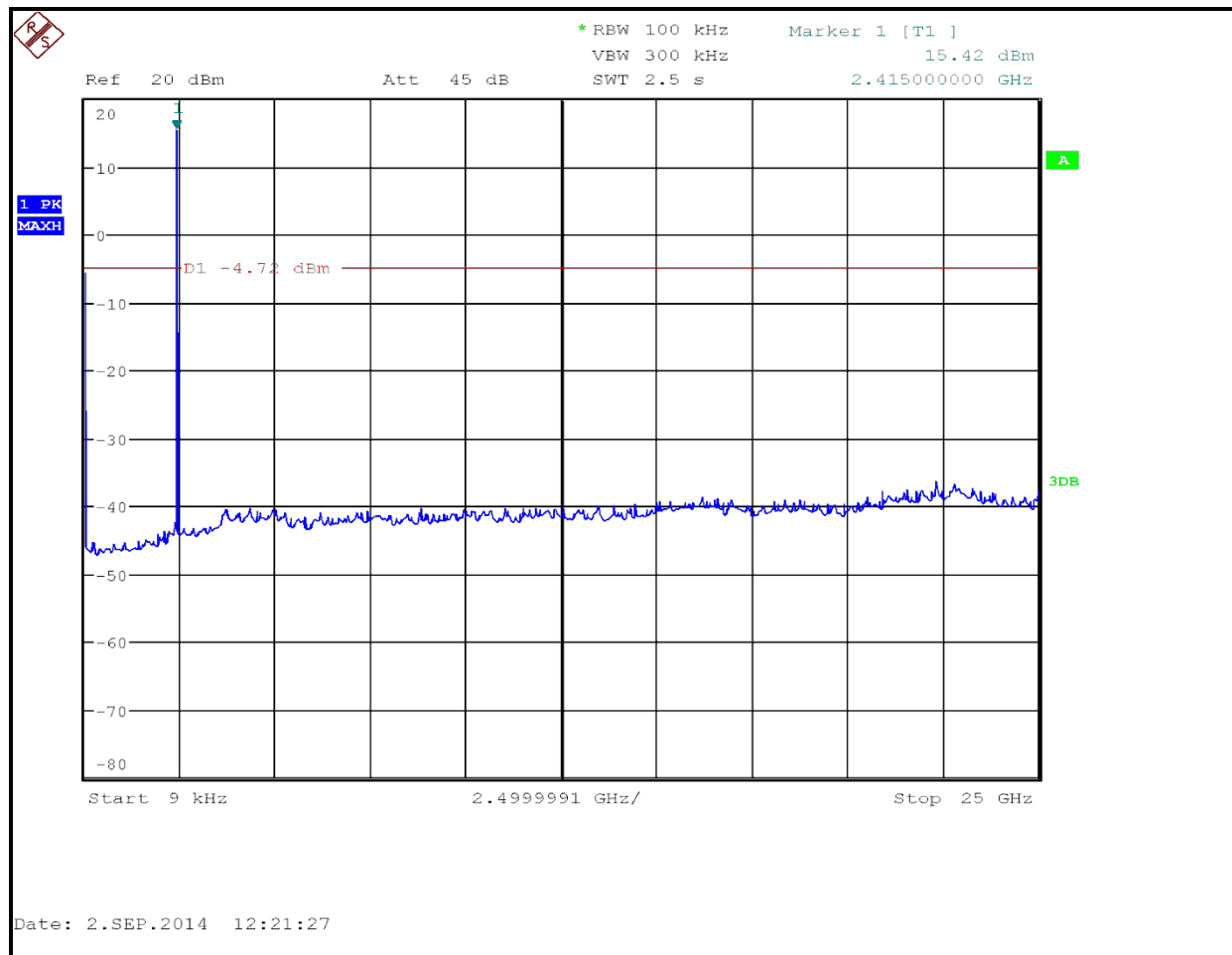

Plot 5-2: Spurious Emissions at Antenna Terminals – 2435 MHz

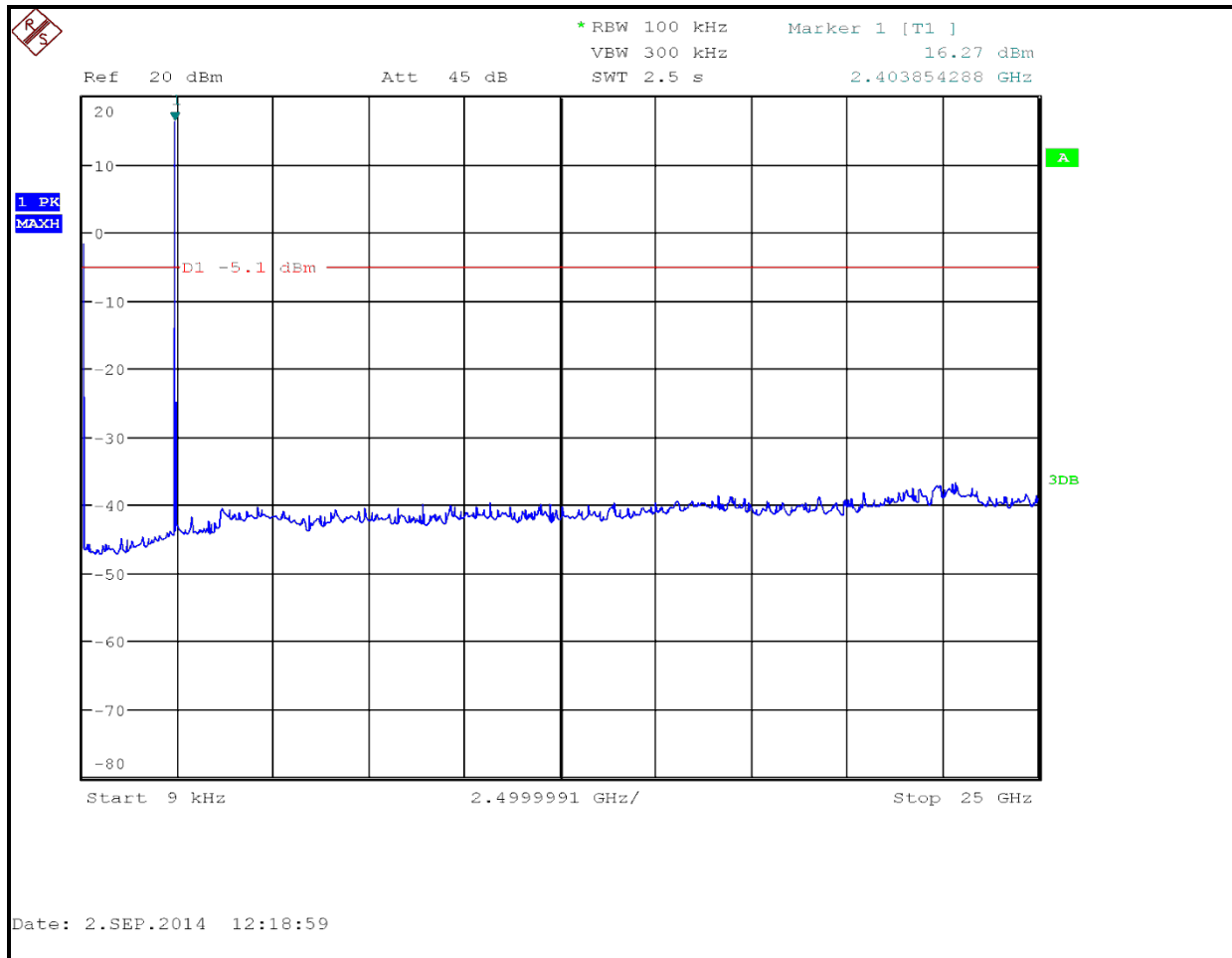

Plot 5-3: Spurious Emissions at Antenna Terminals – 2460 MHz

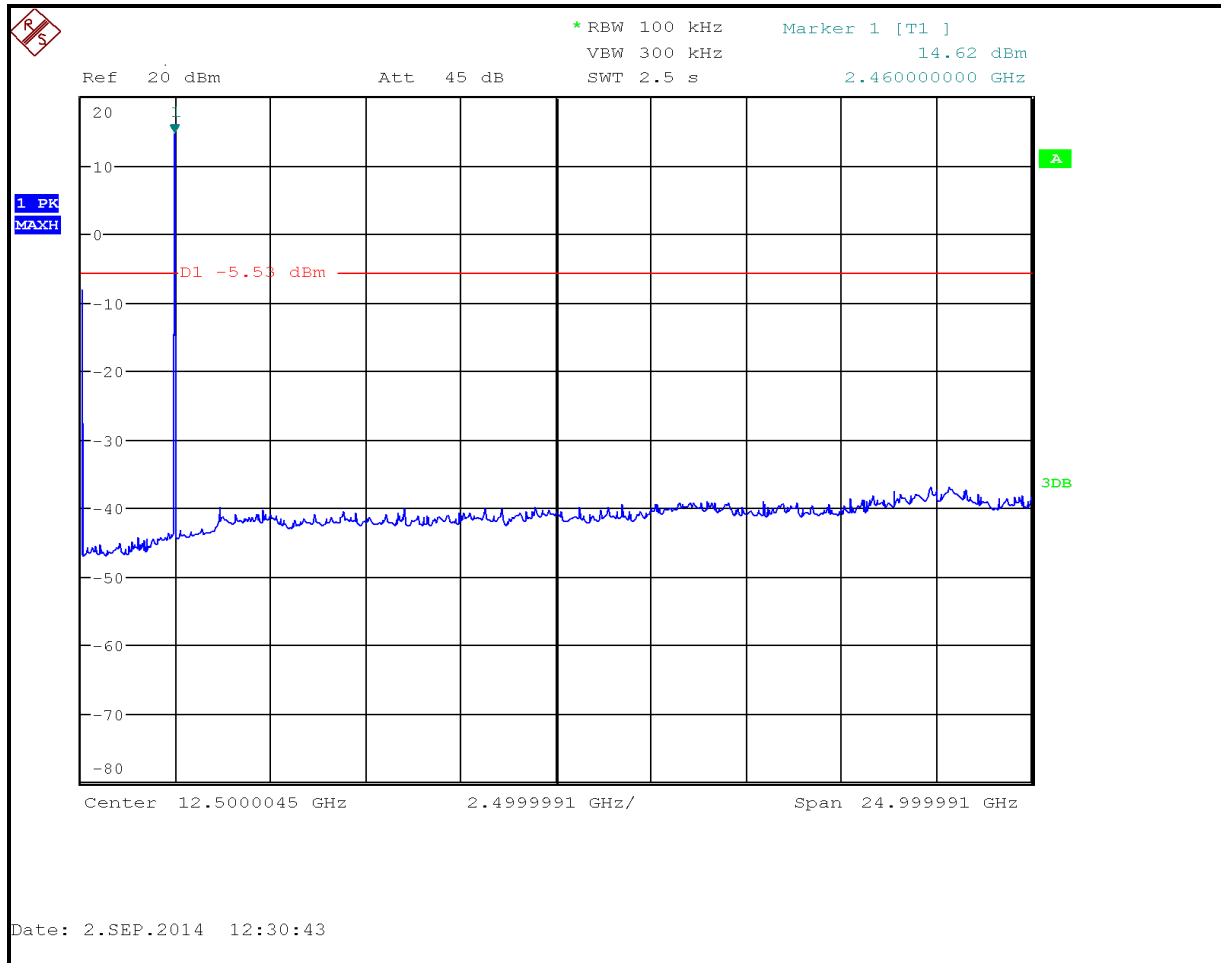

Test Personnel:

Daniel W. Baltzell
Test Engineer

Daniel W. Baltzell
Signature

September 2, 2014
Date of Test

6 Power Spectral Density – FCC §15.247(e); RSS-210 §A8.2

6.1 Power Spectral Density Test Procedure

The power spectral density per FCC 15.247(d) was measured using a 50-ohm spectrum analyzer with the resolution bandwidth set at 3 kHz, the video bandwidth set at equal to or greater than 10 times the RBW, and the sweep time set at 500 seconds. The spectral lines were resolved for the modulated carriers at 2415 MHz, 2435 MHz, and 2460 MHz respectively. These levels are below the +8 dBm limit. See the power spectral density table and plots.

Table 6-1: Power Spectral Density Test Equipment

RTL Asset #	Manufacturer	Model	Part Type	Serial Number	Calibration Due Date
901581	Rohde & Schwarz	1166.1660.50	Spectrum Analyzer	2001006	11/13/14

6.2 Power Spectral Density Test Data

Table 6-2: Power Spectral Density Test Data – 802.11b

Frequency (MHz)	RF Power Level dBm)	Maximum Limit +8 dBm	Pass/Fail
2415	4.1	8	Pass
2435	3.7	8	Pass
2460	2.9	8	Pass

Plot 6-1: Power Spectral Density - 2415 MHz

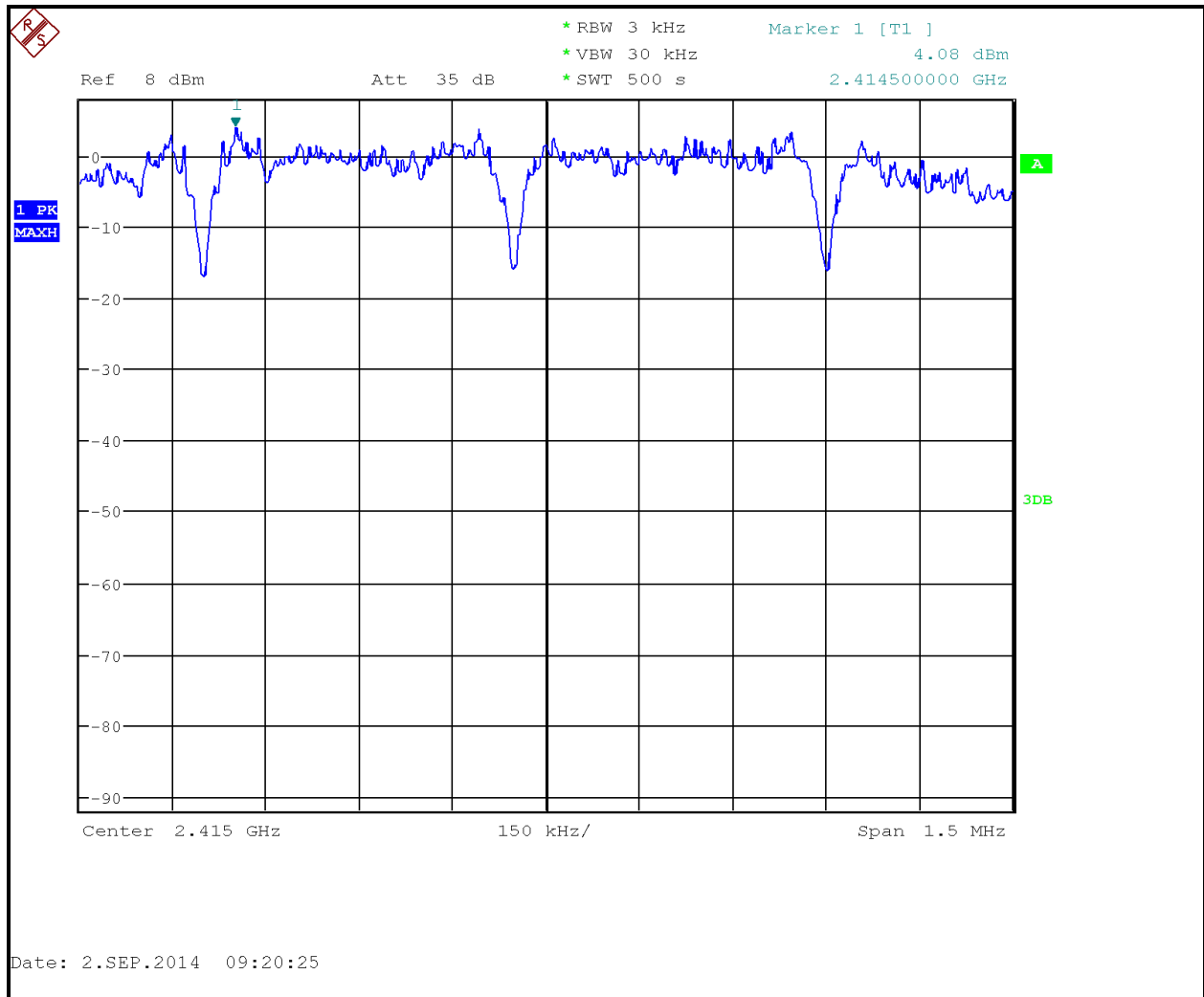

Plot 6-2: Power Spectral Density - 2435 MHz

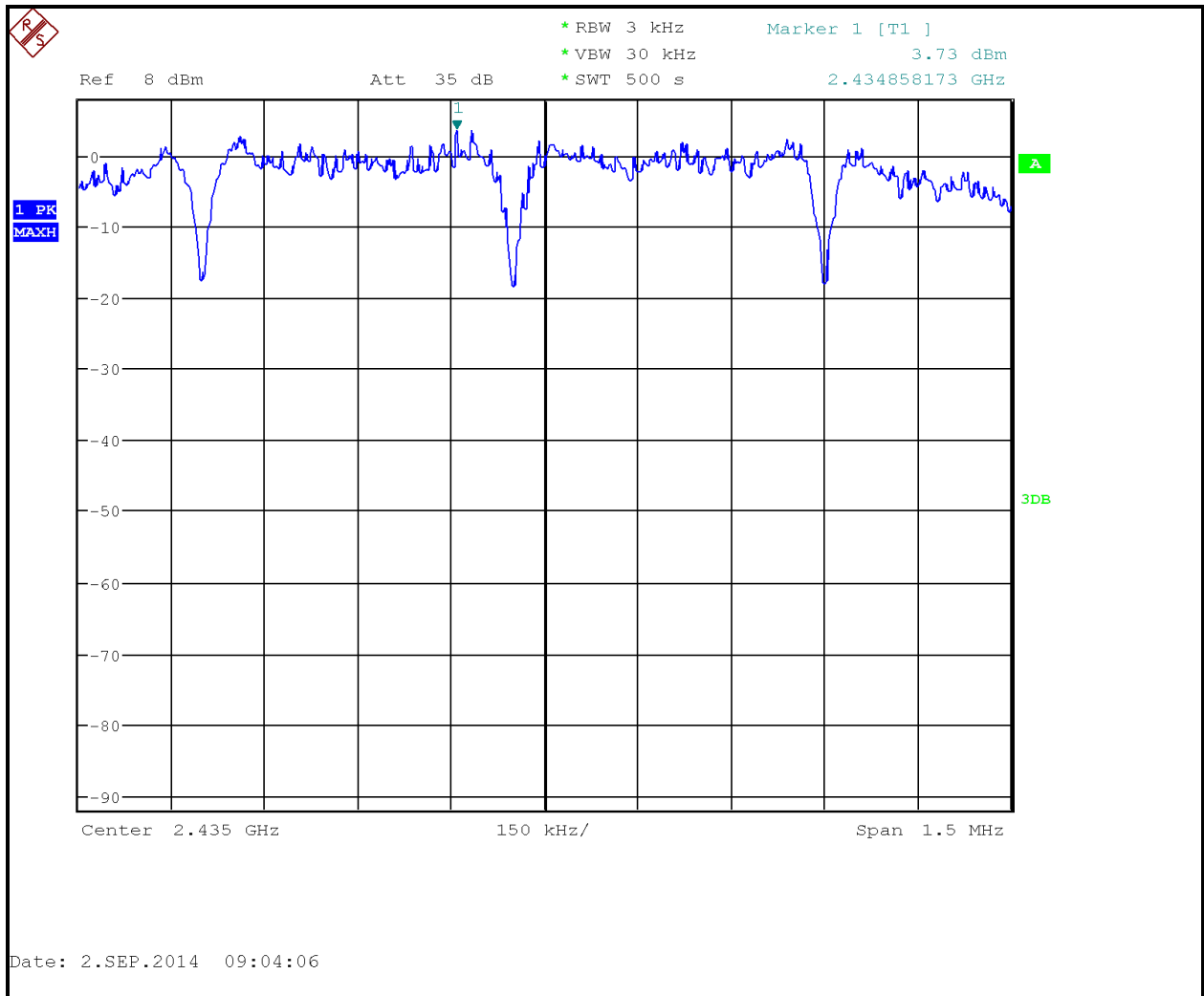

Plot 6-3: Power Spectral Density - 2460 MHz

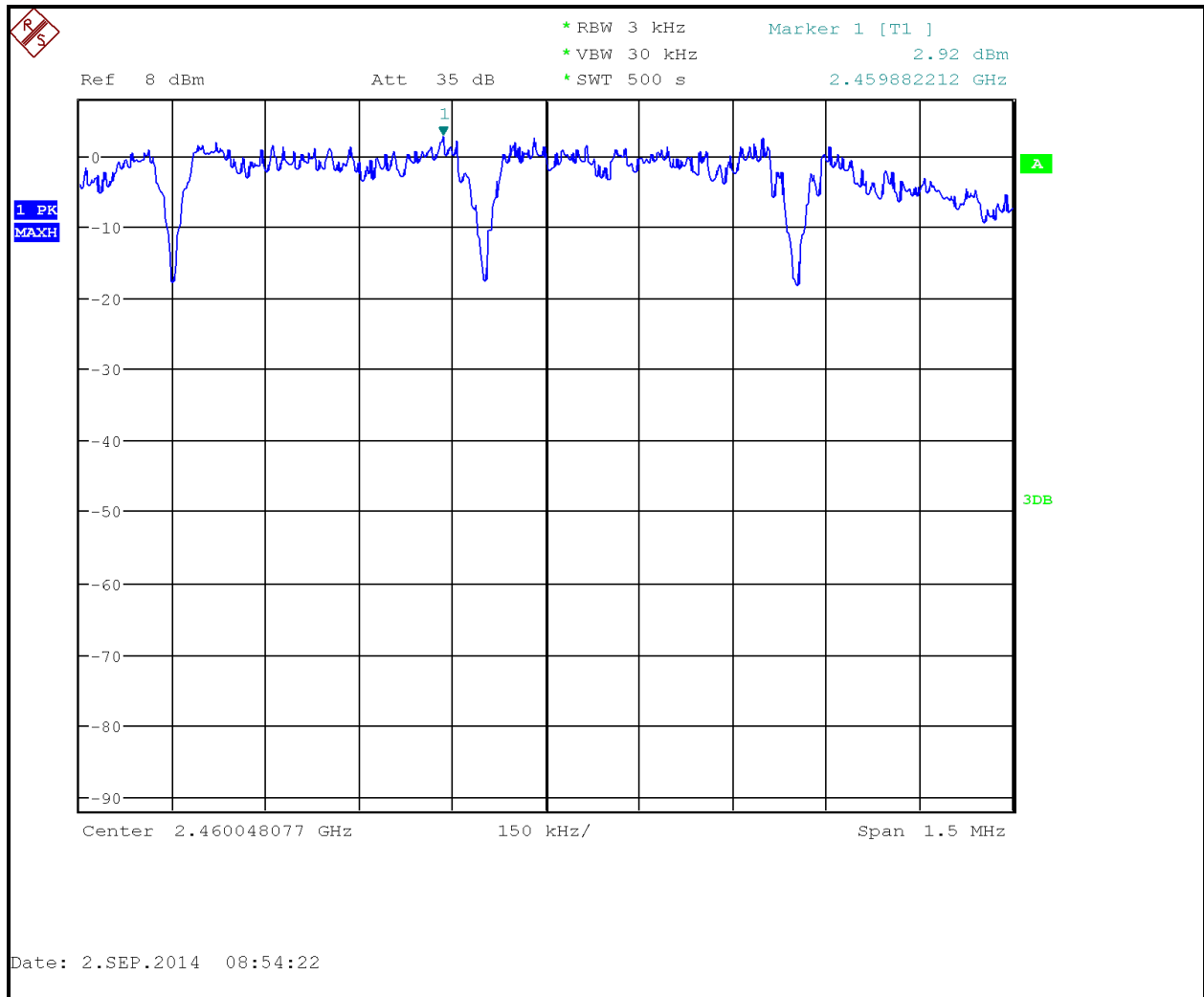

Test Personnel:

Daniel W. Baltzell
Test Engineer

Signature

September 2, 2014
Date of Test

7 Radiated Emissions – FCC §15.209; RSS-210 §A8.5

7.1 Limits of Radiated Emissions Measurement

Frequency (MHz)	Field Strength (uV/m)	Measurement Distance (m)
0.009-0.490	2400/f (kHz)	300
0.490-1.705	2400/f (kHz)	30
1.705-30.0	30	30
30-88	100	3
88-216	150	3
216-960	200	3
Above 960	500	3

As shown in 15.35(b), for frequencies above 1000 MHz, the field strength limits are based on average detector, however, the peak field strength of any emission shall not exceed the maximum permitted average limits specified above by more than 20 dB under any circumstances of modulation.

7.2 Radiated Emissions Measurement Test Procedure

Before final measurements of radiated emissions were made on the open-field three/ten meter range, the EUT was scanned indoors at one and three meter distances. This was done in order to determine its emissions spectrum signature. The physical arrangement of the test system and associated cabling was varied in order to determine the effect on the EUT's emissions in amplitude, direction and frequency. This process was repeated during final radiated emissions measurements on the open-field range, at each frequency, in order to ensure that maximum emission amplitudes were attained.

Final radiated emissions measurements were made on the three/ten-meter, open-field test site. The EUT was placed on a nonconductive turntable 0.8 meters above the ground plane. The spectrum was examined from 9 kHz to the 10th harmonic of the highest fundamental transmitter frequency (24.8 GHz).

At each frequency, the EUT was rotated 360°, and the antenna was raised and lowered from 1 to 4 meters in order to determine the emission's maximum level. Measurements were taken using both horizontal and vertical antenna polarizations. For frequencies between 30 and 1000 MHz, the spectrum analyzer's 6 dB bandwidth was set to 120 kHz, and the analyzer was operated in the CISPR quasi-peak detection mode. For emissions above 1000 MHz, emissions are measured using the average detector function with a minimum resolution bandwidth of 1 MHz. No video filter less than 10 times the resolution bandwidth was used. The highest emission amplitudes relative to the appropriate limit were measured and recorded in this report.

Table 7-1: Radiated Emissions Test Equipment

RTL Asset #	Manufacturer	Model	Part Type	Serial Number	Calibration Due Date
900932	Hewlett Packard	8449B OPT H02	Preamplifier (1-26.5 GHz)z	3008A00505	8/27/15
900772	EMCO	3161-02	Horn Antenna (2-4 GHz)	9804-1044	4/20/15
900321	EMCO	3161-03	Horn Antenna (4.0-8.2 GHz)	9508-1020	4/20/15
900323	EMCO	3160-07	Horn Antenna (8.2-12.4 GHz)	9605-1054	4/20/15
900356	EMCO	3160-08	Horn Antenna (12.4-18 GHz)	9607-1044	4/20/15
900325	EMCO	3160-9	Horn Antenna (18-26.5 GHz)	9605-1051	4/19/15
900151	Rohde and Schwarz	HFH2-Z2	Loop Antenna (9 kHz-30 MHz)	827525/019	3/4/15
901629	Teledyne Cougar	A4C2123	Amplifier	003-003	9/4/15
900878	Rhein Tech Laboratories	AM3-1197-0005	3 meter antenna mast, polarizing	Outdoor Range 1	Not Required
901242	Rhein Tech Laboratories	WRT-000-0003	Wood rotating table	N/A	Not Required
901581	Rohde & Schwarz	1166.1660.50	Spectrum Analyzer	2001006	11/13/14
900724	Antenna Research Associates, Inc.	LPB-2520	BiLog Antenna (25-1000MHz)	1037	4/19/15
901592	Insulated Wire Inc.	KPS-1503-3600-KPR	SMK RF Cables 20'	NA	8/27/15
901593	Insulated Wire Inc.	KPS-1503-360-KPR	SMK RF Cables 36"	NA	8/27/15

7.3 Radiated Emissions Harmonics/Spurious Test Data

Table 7-2: Radiated Emissions Harmonics/Spurious - 2415 MHz – Peak Detector

Emission Frequency (MHz)	Peak Analyzer Reading (dBuV/m) (1 MHz RBW/VBW)	Site Correction Factor (dB/m)	Peak Corrected (dBuV/m)	Peak Limit (dBuV/m)	Peak Margin (dB)
4830.0	55.0	-1.1	53.9	74.0	-20.1
12075.0	49.5	10.3	59.8	74.0	-14.2
14490.0	43.7	14.7	58.4	74.0	-15.6
19320.0	45.0	20.5	65.5	74.0	-8.5

Table 7-3: Radiated Emissions Harmonics/Spurious - 2415 MHz – Average Detector

Emission Frequency (MHz)	Average Analyzer Reading (dBuV/m) (1 MHz RBW/VBW)	Site Correction Factor (dB/m)	Average Corrected (dBuV/m)	Average Limit (dBuV/m)	Average Margin (dB)
4830.0	45.7	-1.1	44.6	54.0	-9.4
12075.0	37.1	10.3	47.4	54.0	-6.6
14490.0	29.4	14.7	44.1	54.0	-9.9
19320.0	29.6	20.5	50.1	54.0	-3.9

Table 7-4: Radiated Emissions Harmonics/Spurious - 2435 MHz – Peak Detector

Emission Frequency (MHz)	Peak Analyzer Reading (dBuV/m) (1 MHz RBW/VBW)	Site Correction Factor (dB/m)	Peak Corrected (dBuV/m)	Peak Limit (dBuV/m)	Peak Margin (dB)
4870.0	54.5	-1.1	53.4	74.0	-20.6
7305.0	60.0	0.9	60.9	74.0	-13.1
12175.0	49.4	11.0	60.4	74.0	-13.6
19480.0	44.8	20.2	65.0	74.0	-9.0

Table 7-5: Radiated Emissions Harmonics/Spurious - 2435 MHz – Average Detector

Emission Frequency (MHz)	Peak Analyzer Reading (dBuV/m) (1 MHz RBW/VBW)	Site Correction Factor (dB/m)	Peak Corrected (dBuV/m)	Peak Limit (dBuV/m)	Peak Margin (dB)
4870.0	45.7	-1.1	44.6	54.0	-9.4
7305.0	48.4	0.9	49.3	54.0	-4.7
12175.0	36.6	11.0	47.6	54.0	-6.4
19480.0	29.6	20.2	49.8	54.0	-4.2

Table 7-6: Radiated Emissions Harmonics/Spurious - 2460 MHz – Peak Detector

Emission Frequency (MHz)	Peak Analyzer Reading (dBuV/m) (1 MHz RBW/VBW)	Site Correction Factor (dB/m)	Peak Corrected (dBuV/m)	Peak Limit (dBuV/m)	Peak Margin (dB)
4920.0	53.9	-1.0	52.9	74.0	-21.1
7380.0	59.4	1.0	60.4	74.0	-13.6
12300.0	49.2	11.9	61.1	74.0	-12.9
19680.0	45.6	20.4	66.0	74.0	-8.0
22140.0	44.2	22.0	66.2	74.0	-7.8

Table 7-7: Radiated Emissions Harmonics/Spurious - 2460 MHz – Average Detector

Emission Frequency (MHz)	Peak Analyzer Reading (dBuV/m) (1 MHz RBW/VBW)	Site Correction Factor (dB/m)	Peak Corrected (dBuV/m)	Peak Limit (dBuV/m)	Peak Margin (dB)
4920.0	44.8	-1.0	43.8	54.0	-10.2
7380.0	48.3	1.0	49.3	54.0	-4.7
12300.0	37.2	11.9	49.1	54.0	-4.9
19680.0	30.1	20.4	50.5	54.0	-3.5
22140.0	29.8	22.0	51.8	54.0	-2.2

Test Personnel:

Daniel W. Baltzell
 Test Engineer

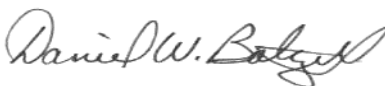

Signature

August 29, 2014
 Date of Test

8 AC Conducted Emissions - FCC §15.207; RSS-Gen §7.2.4: Conducted Limits

8.1 Conducted Limits - §15.207

Frequency of emission (MHz)	Conducted limit (dB μ V)	
	Quasi-peak	Average
0.15–0.5	66 to 56*	56 to 46*
0.5–5	56	46
5–30	60	50

*Decreases with the logarithm of the frequency.

8.2 Conducted Line Emissions Test Procedure

The power line conducted emission measurements were performed in a Series 81 type shielded enclosure manufactured by Rayproof. The EUT was assembled on a wooden table 80 centimeters high. Power was fed to the EUT through a 50 ohm / 50 microhenry Line Impedance Stabilization Network (EUT LISN). The EUT LISN was fed power through an A.C. filter box on the outside of the shielded enclosure. The filter box and EUT LISN housing are bonded to the ground plane of the shielded enclosure. A second LISN, the peripheral LISN, provides isolation for the EUT test peripherals. This peripheral LISN was also fed A.C. power. A metal power outlet box, which is bonded to the ground plane and electrically connected to the peripheral LISN, powers the EUT host peripherals.

The spectrum analyzer was connected to the A.C. line through an isolation transformer. The 50 ohm output of the EUT LISN was connected to the spectrum analyzer input through a Solar high-pass filter. The filter is used to prevent overload of the spectrum analyzer from noise below 100 kHz. Conducted emission levels were measured on each current-carrying line with the spectrum analyzer operating in the CISPR quasi-peak mode (or peak mode if applicable). The analyzer's 6 dB bandwidth was set to 9 kHz. No video filter less than 10 times the resolution bandwidth was used. Average measurements are performed in linear mode using a 10 kHz resolution bandwidth, a 1 Hz video bandwidth, and by increasing the sweep time in order to obtain a calibrated measurement. The emission spectrum was scanned from 150 kHz to 30 MHz. The highest emission amplitudes relative to the appropriate limit were measured and have been recorded in this report.

Table 8-1: Conducted Line Emissions Test Equipment

RTL Asset #	Manufacturer	Model	Part Type	Serial Number	Calibration Due Date
901083	AFJ International	LS16	16A LISN (110 V)	16010020080	8/27/15
901581	Rohde & Schwarz	FSU	Spectrum Analyzer	1166.1660.50	11/13/14

8.3 Conducted Line Emission Test Description

The conducted test was performed with the EUT exercise program loaded, and the emissions were scanned between 150 kHz to 30 MHz on the NEUTRAL SIDE and PHASE SIDE.

8.4 Conducted Line Emission Test Data

Plot 8-1: Conducted Emissions (Phase Side) (Standby Mode)

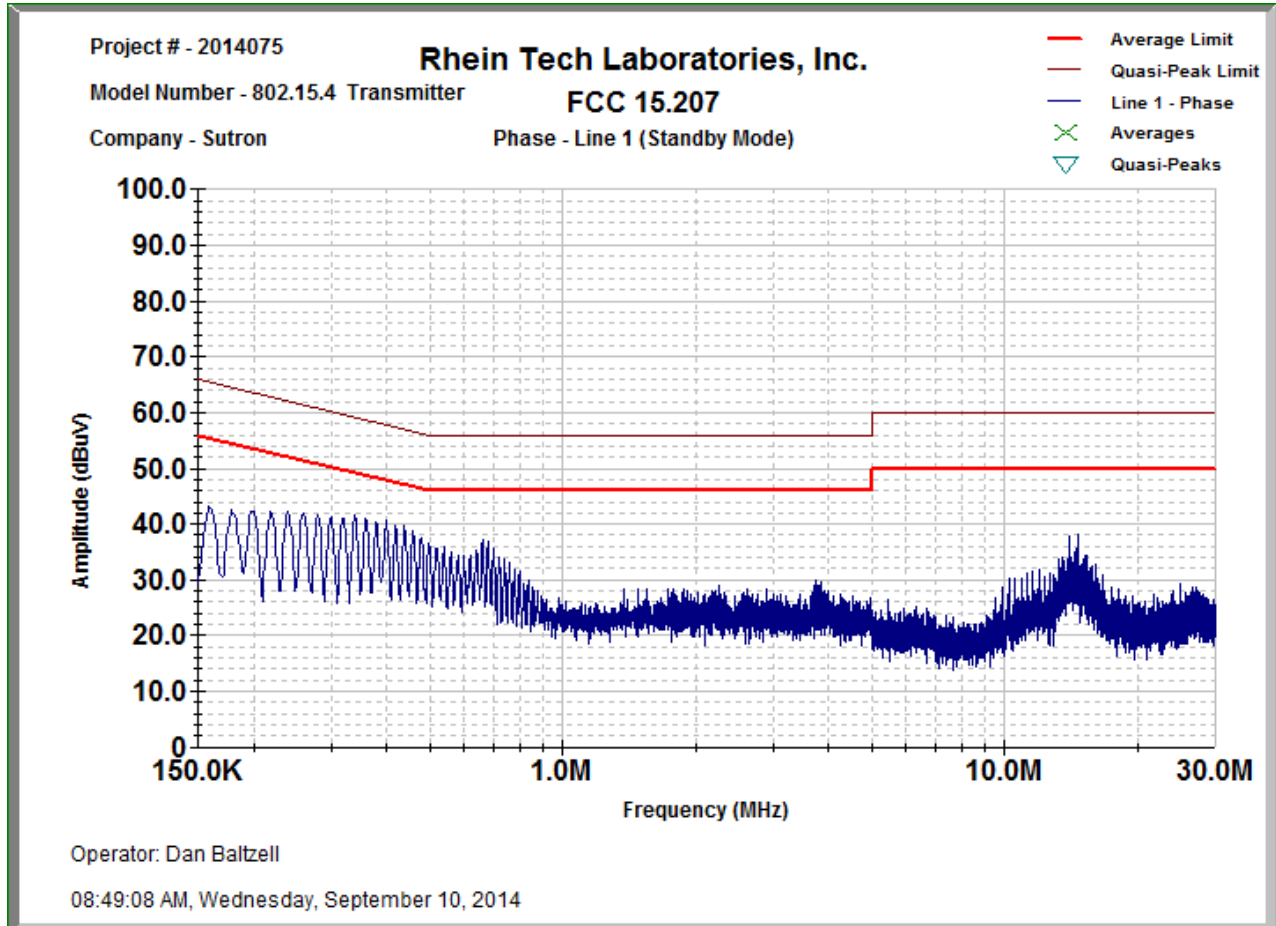

Plot 8-2: Conducted Emissions (Neutral Side) (Standby Mode)

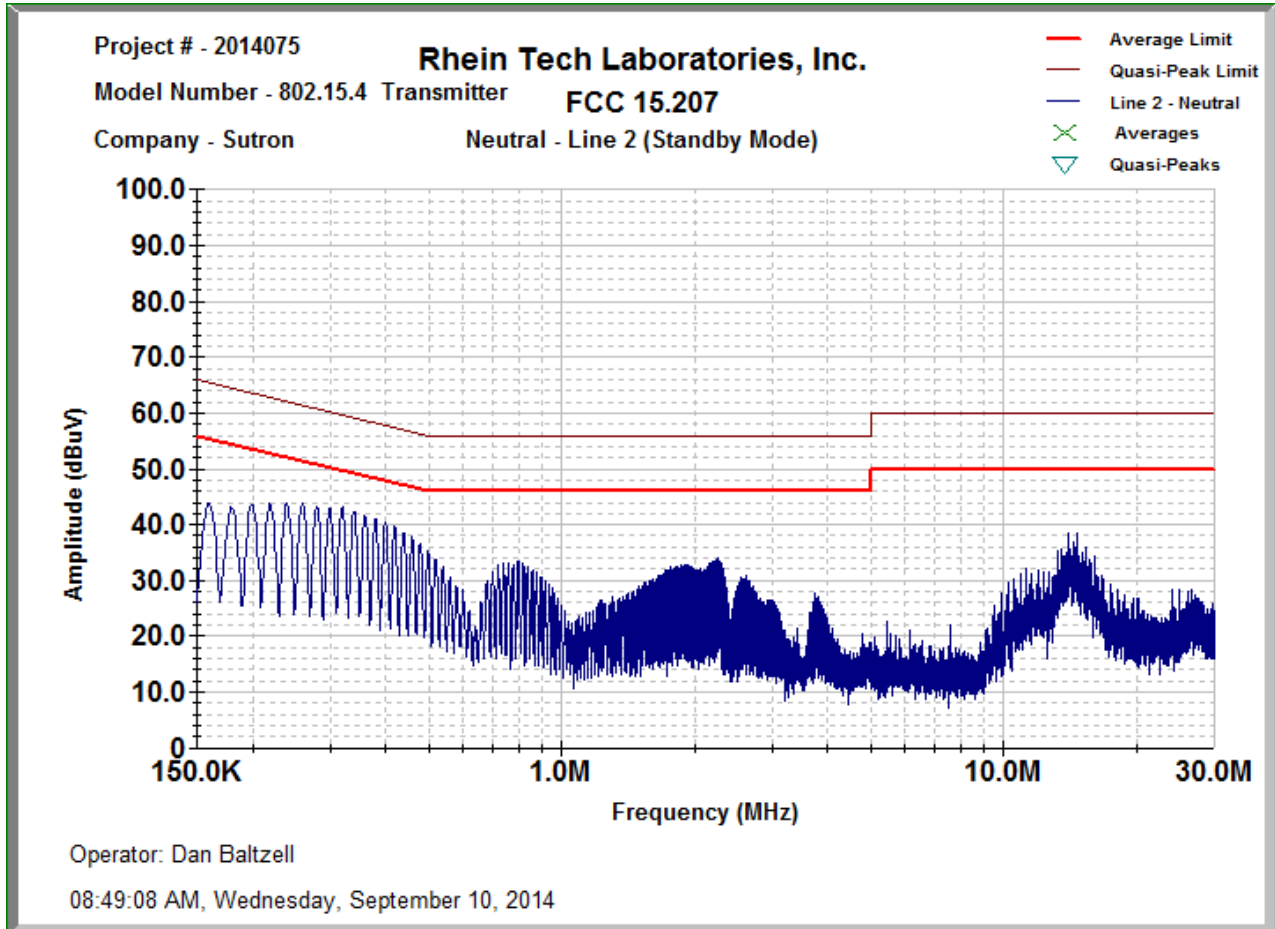

Plot 8-3: Conducted Emissions (Phase Side) (Transmit Mode, Center Channel 6)

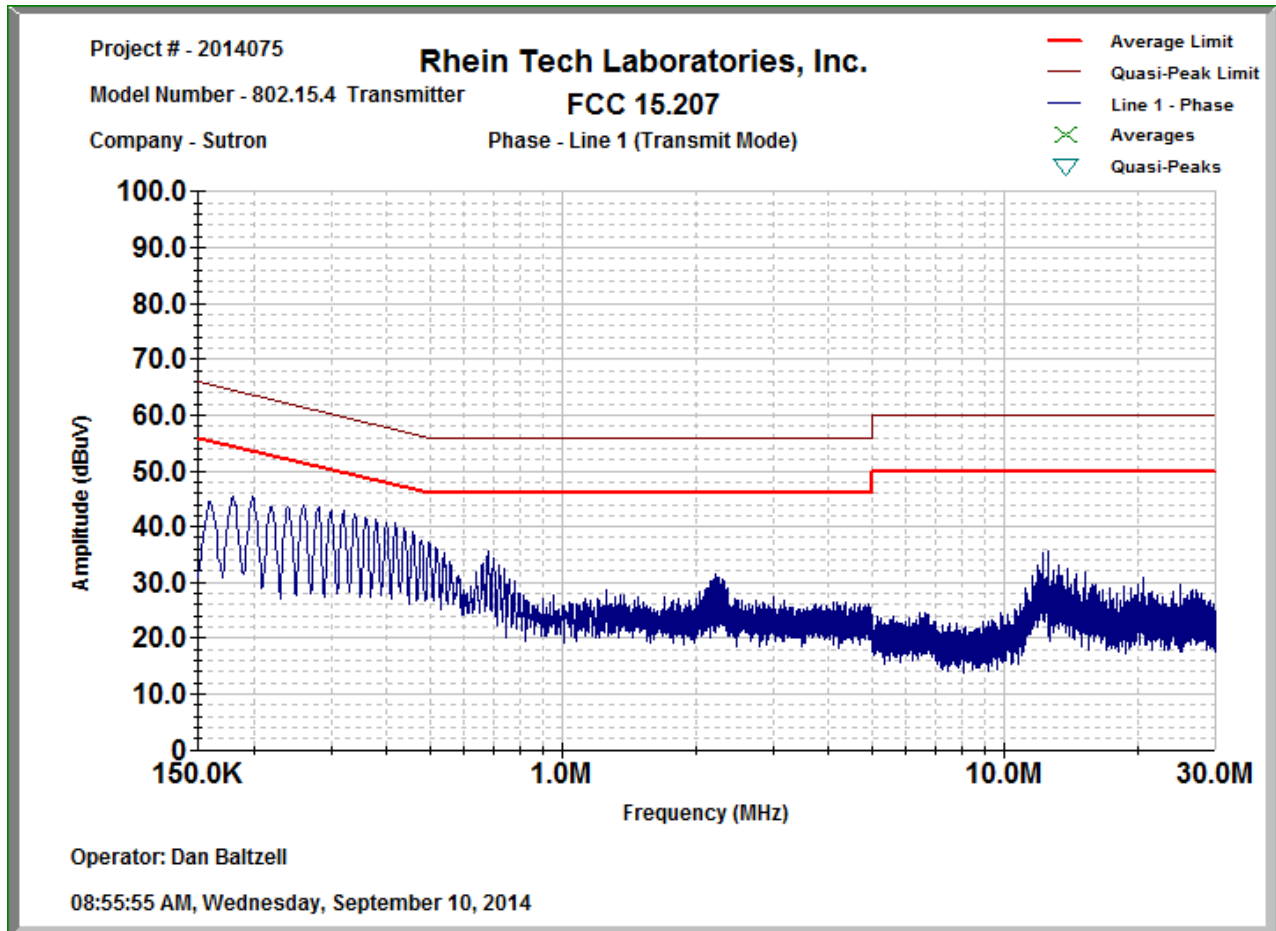

Plot 8-4: Conducted Emissions (Neutral Side) (Transmit Mode, Center Channel 6)

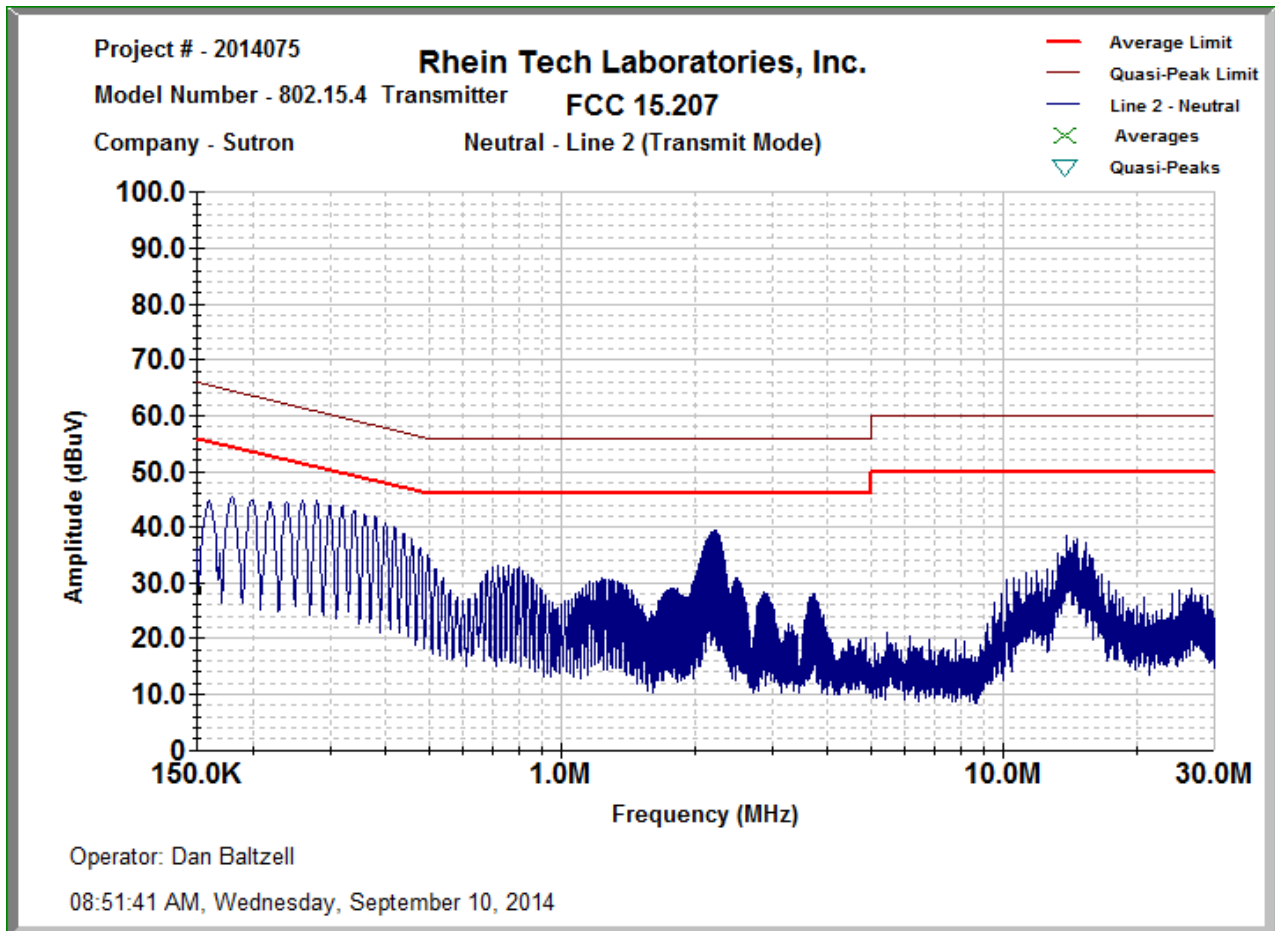

Test Personnel:

Daniel W. Baltzell
Test Engineer

Signature

September 10, 2014
Date of Test

9 6 dB Bandwidth – FCC §15.247(a)(2); RSS-210 §A8.2

9.1 6 db Bandwidth Test Procedure – Minimum 6 dB Bandwidth

The minimum 6 dB bandwidths per FCC 15.247(a)(2) were measured using a 50-ohm spectrum analyzer with the resolution bandwidth set at 100 kHz, and the video bandwidth set at 300 kHz. The device was modulated. The minimum 6 dB bandwidths are presented below.

Table 9-1: 6 dB Bandwidth Test Equipment

RTL Asset #	Manufacturer	Model	Part Type	Serial Number	Calibration Due Date
901581	Rohde & Schwarz	1166.1660.50	Spectrum Analyzer	2001006	11/13/14

9.2 6 dB Modulated Bandwidth Test Data

Table 9-2: 6 dB Bandwidth Test Data

Frequency (MHz)	6 dB Bandwidth (MHz)	Minimum Limit (kHz)	Pass/Fail
2415	1.5	500	Pass
2435	1.5	500	Pass
2460	1.6	500	Pass

Plot 9-1: 6 dB Bandwidth - 2415 MHz

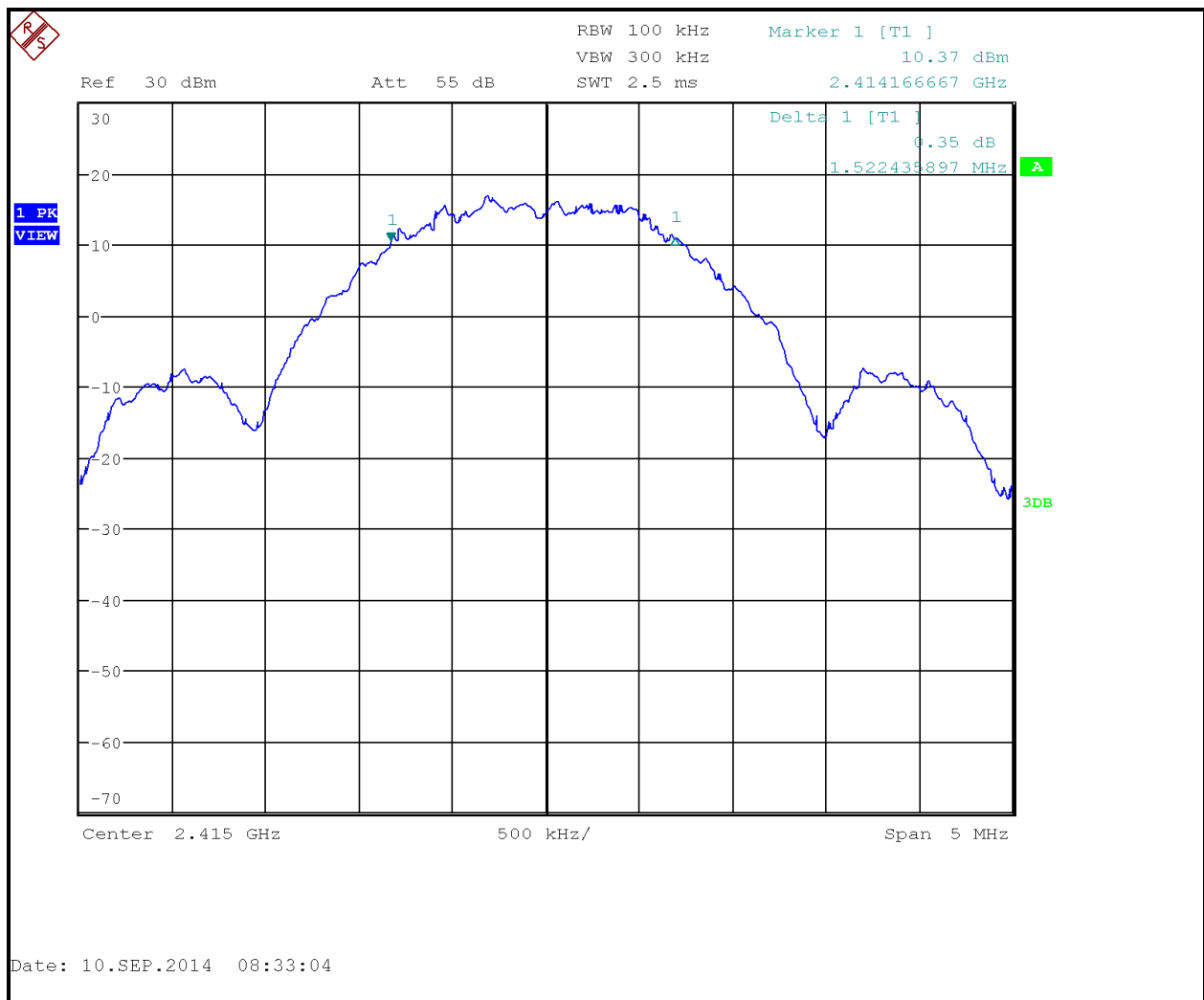

Plot 9-2: 6 dB Bandwidth - 2435 MHz

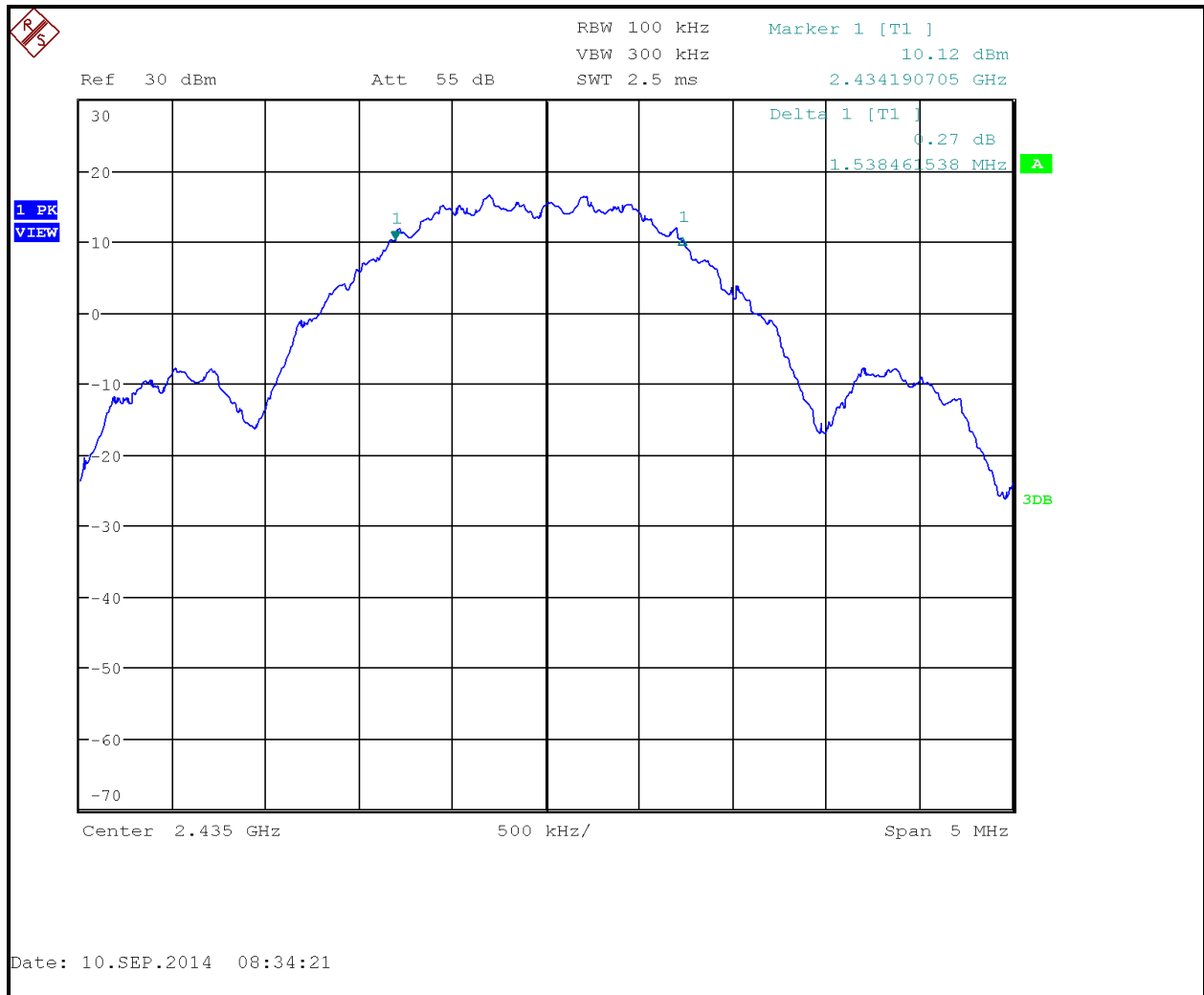

Plot 9-3: 6 dB Bandwidth - 2460 MHz

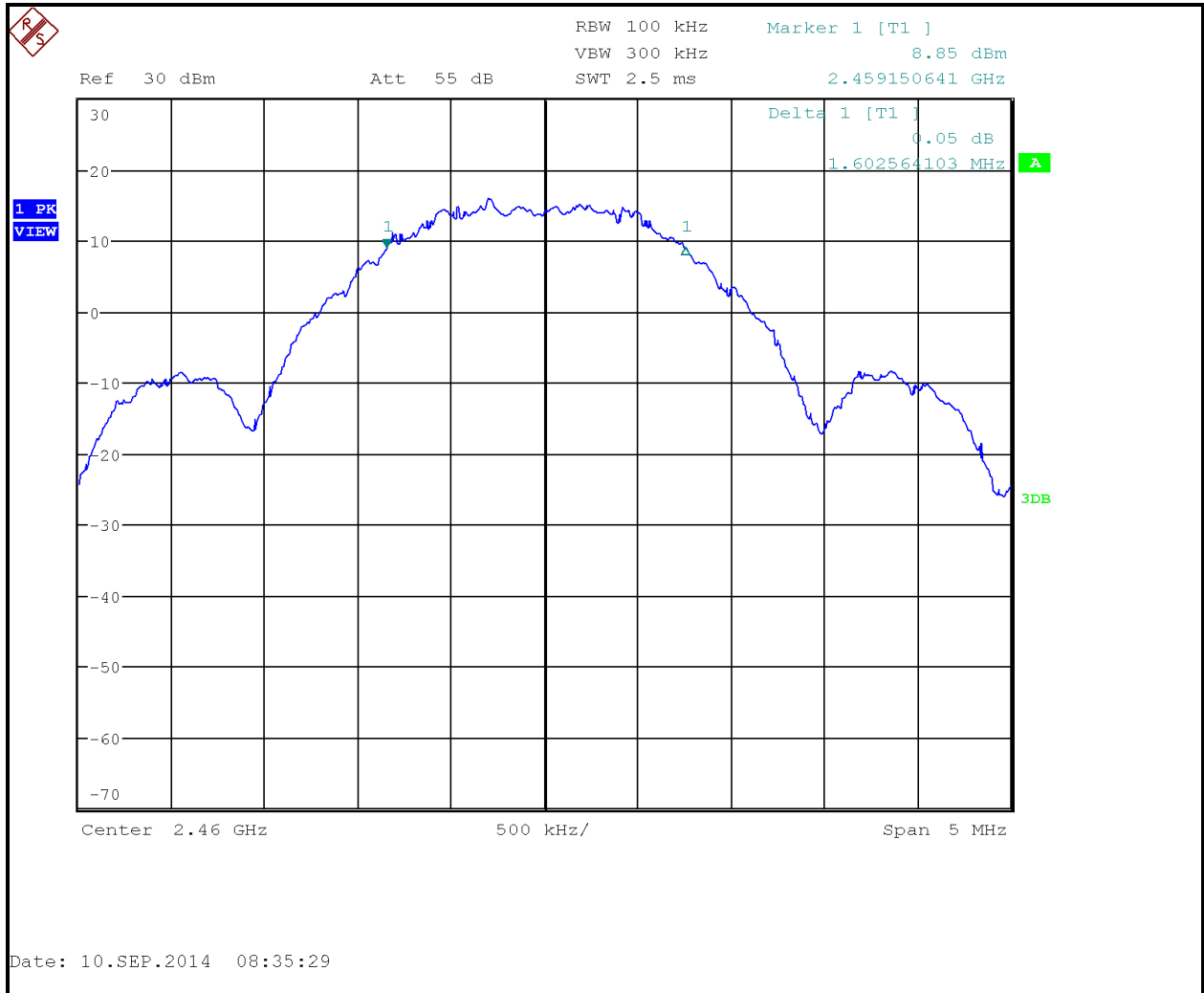

Test Personnel:

Daniel W. Baltzell
Test Engineer

Signature

September 10, 2014
Date of Test

10 Conclusion

The data in this measurement report shows that the EUT as tested, Sutron Corporation 802.15.4 Transmitter, Model # 6461-1311-1, FCC ID: HDB-6461-1311-1, IC: 1088A-646113111, complies with the applicable requirements for Limited Modular Approval under Parts 2 and 15 of the FCC Rules and Regulations, and IC RSS-210 and RSS-Gen.