

Honeywell

Thor VM1A

Vehicle-Mounted Computer
powered by Android™

User Guide

Disclaimer

Honeywell International Inc. (“HII”) reserves the right to make changes in specifications and other information contained in this document without prior notice, and the reader should in all cases consult HII to determine whether any such changes have been made. HII makes no representation or warranties regarding the information provided in this publication.

HII shall not be liable for technical or editorial errors or omissions contained herein; nor for incidental or consequential damages resulting from the furnishing, performance, or use of this material. HII disclaims all responsibility for the selection and use of software and/or hardware to achieve intended results.

This document contains proprietary information that is protected by copyright. All rights are reserved. No part of this document may be photocopied, reproduced, or translated into another language without the prior written consent of HII.

Copyright © 2022 Honeywell Group of Companies. All rights reserved.

Web Address: sps.honeywell.com

Trademarks

Google and Android are trademarks of Google LLC.

Bluetooth trademarks are owned by Bluetooth SIG, Inc., U.S.A. and licensed to Honeywell.

SD is a registered trademark of SD-3C, LLC.

Qualcomm and Snapdragon are registered trademarks or trademarks of Qualcomm Incorporated in the United States and/or other countries.

Other product names or marks mentioned in this document may be trademarks or registered trademarks of other companies and are the property of their respective owners.

Patents

For patent information, refer to www.hsmpats.com.

TABLE OF CONTENTS

Customer Support	ix
Technical Assistance	ix
Product Service and Repair	ix
Limited Warranty	ix
Chapter 1 - About the Computer Features.....	1
About the Thor VM1A Vehicle-Mounted Computer.....	1
Model Overview.....	2
Features of the VM1A	2
Front View - Thor VM1A.....	2
Back View - Thor VM1A.....	3
Access Panels - Thor VM1A	3
Power Management Modes	4
About the Power Supply.....	4
Vehicle DC Power Supply.....	4
External AC Power Supply.....	5
Uninterruptible Power Supply	5
Backup Battery	6
Fuse.....	7
Disconnect the UPS Battery.....	7
Replace the UPS Battery.....	9
About the Battery Status.....	11
Check the Battery Level and Usage	12
Enable Airplane Mode	12
Power On the Computer	13

Power Cable Cautions	14
Power Cable Routing	14
Power Mode	15
Welcome Screen	16
Touch Screen Calibration.....	16
Unlock the Screen.....	16
Change the Screen Lock to Protect the Computer.....	17
Configure the Screen Backlight.....	17
Screen Blanking	18
Motion Detection Action.....	18
Motion Timeout Settings.....	18
Motion Detection Source	18
Zoom Zone.....	19
About the Keypad.....	20
Keyboard Options.....	20
USB Keyboard/Mouse.....	20
Keyboard LEDs.....	21
System LEDs	22
Connection LEDs	23
About the Audio Features	24
Adjust Speaker Volume	24
Audio Settings	24
About the Defroster.....	25
Automatic mode.....	25
Manual mode.....	26
Configure the Defroster in the Settings App	26
Defroster Parameters	26
Insert an SD Card.....	27
Equipment Required.....	27
Installation Procedure.....	27
Scanners.....	29

Chapter 2 - About the User Interface and Applications.....31

About the User Interface	31
Navigation Buttons	32
About Status Bar Icons	32
Remap a Button or Key	33
Restore Default Button Action.....	34
View and Manage Notifications.....	34
Open Quick Settings.....	35
Customize the Home Screen	35
Customize the Favorites Tray.....	35
Use Google™ Search.....	36
About Screen Gestures.....	36
Set the Time Zone	37
Set PCAP Touch Screen Sensitivity Mode	37
About Honeywell Applications	38
Applications You Can Download to the Computer.....	39
About Honeywell Enterprise Browser	39
About Honeywell Launcher	39
About UEMConnect.....	40
Honeywell SmartTE	40
Unlock Developer Options.....	40

Chapter 3 - Configure the Computer43

How to Configure the Computer	43
Start the Settings App.....	43
About the Structure of the Settings App	43
About Network Communications	54
Connect to a Wi-Fi Network.....	54
Connect to an Ethernet Network.....	55
How to Connect to Virtual Private Networks.....	56
About Wireless Security	57
About Certificates.....	57
About Bluetooth Communications	59

Connect a Bluetooth Device	59
Rename the Computer and View File History	59
Rename or Unpair a Paired Device.....	60
About the Scanner Edge App	60
Connect a Bluetooth Scanner	60
Unpair a Paired Scanner	61
USB Troubleshooting	61
About Near Field Communication (NFC)	61
Developer and Device Management Information	62
About Provisioning Mode	62
Enable or Disable Provisioning Mode.....	63
About Wi-Fi Staging.....	63
Staging Devices	63
Log Files.....	67
About Voice Wedge	67
Define Trigger Mode.....	67
Associate Applications	68
Define Key Commands.....	68
Select Data Type	68
To Use Voice Wedge in an App.....	69

Chapter 4 - About the VM docks 71

About the Docks	71
Dock Overview.....	72
VM1D Standard Dock.....	72
VM3D Enhanced Dock.....	72
Enhanced Dock with Thor VX8/VX9 Screen Blanking	73
VMXD Enhanced Dock for Off-Vehicle Use	73
Features of the Dock.....	74
Front View - Dock	74
Back View - Dock	74
Top View - Enhanced Dock.....	75
Dock I/O Pin Cover	76

Padlock	76
Laptop Security Cable	77
External Connectors Overview.....	77
Serial Connector (COM1 and COM2).....	78
USB Connector(s).....	79
Ethernet Connector	80
Audio Connector	80
Power Supply Connector	81
Antenna Connections	81

Chapter 5 - Mounting And Installing83

About Mounting the VM1A.....	83
Select Mounting Location	84
General Mounting Outline.....	84
Install RAM Mount.....	85
RAM Ball Mount	85
RAM Clamp Mount.....	86
RAM Plate Mount with RAM Ball.....	87
Attach RAM Mount Ball to the Dock	88
Attach Thor VM1A Assembly to RAM Mount	88
Install U Bracket Mount or Adapter	90
Install Table Stand	93
Place Thor VM1A in the Dock.....	95
About the 802.11 Remote Antenna	96
Mount the 802.11 Remote Antenna	97
Connect Power	98
12-48 VDC Vehicles (10-60 VDC Direct Connection).....	99
60-144 VDC Vehicles (50-150 VDC Power Supply, Screws on Side of Lid)	104
60-144 VDC Vehicles (50-150 VDC Power Supply, Screws on Top of Lid)	108
VX5/VX6/VX7 Adapter Cable.....	113
Thor VX8/Thor VX9 Adapter Cable	114
CV60/CV61 Adapter Cable	116
Screen Blanking Installation.....	117

Enhanced Dock with Thor VX8/Thor VX9 Screen Blanking.....	121
External AC/DC Power Supply	124
Connect USB Host	126
Connect USB Client.....	127
Connect Serial Device.....	129
Connect a Tethered Scanner	129
Connect Headset Cable	130
Strain Relief Cable Clamps.....	131

Chapter 6 - Manage and Maintain the Computer.....133

About Software Updates and Cyber Security	133
Software Downloads	133
Install Software Updates with AutoInstall	134
Optional SD Card Method.....	135
About the Honeywell Upgrader.....	135
Install OTA Updates.....	135
Restart (Reboot) the Computer.....	138
About an Enterprise Data Reset.....	138
Before You Begin	138
Enterprise Data Reset the Computer	139
About a Factory Data Reset	139
Before You Begin	139
Factory Data Reset the Computer	140
Clean the Computer.....	140
Maintenance - Vehicle Mounted Devices	140
Replace the Front Panel.....	141
Front Panel Options	141
Equipment Required.....	141
Replacement Procedure.....	141

Appendix A - Key Maps143

Keypad Key Map	143
----------------------	-----

Appendix B - Specifications and Reference Materials149

Technical Specifications149
 Thor VM1A.....149
 VM1D Standard Dock150
 VM3D Enhanced Dock150
 VMXD Enhanced Dock151
 VMXD Enhanced Dock for Off-Vehicle Use (QM3AC)152
Dimensions.....152
 Thor VM1A.....152
 VM1D Standard Dock153
 VM3D and VMXD Enhanced Dock.....153
Environmental Specifications.....153
 Thor VM1A and Dock.....153
Port and Connector Pinouts154
 Power Supply Connector154
 COM1 and COM2 Connector.....155
 USB and USB1 Connector156
 USB Host/Client Y Cable.....156
 USB Host to Scanner Cable.....157
 USB2 Connector158
 USB Dual Host Y Cable.....159
 Audio Connector160
 Headset Adapter Cable.....160

Appendix C - Agency Information.....163

Label Locations163

Customer Support

Technical Assistance

Go to honeywell.com/PSStechnicalsupport and select **Support** to search our knowledge base for a solution or to log into the Technical Support portal.

Product Service and Repair

Honeywell International Inc. provides service for all of its products through service centers throughout the world. Go to sps.honeywell.com and select **Support** to find a service center near you or to get a Return Material Authorization number (RMA #) before returning a product.

For ongoing and future product quality improvement initiatives, the computer comes equipped with an embedded device lifetime counter function. Honeywell may use the lifetime counter data for future statistical reliability analysis as well as ongoing quality, repair and service purposes.

Limited Warranty

For warranty information, go to sps.honeywell.com and select **Support > Warranties**.

ABOUT THE COMPUTER FEATURES

This chapter introduces the Thor VM1A Vehicle-Mounted Computer. Use this chapter to learn about the basic computer features and functions.

About the Thor VM1A Vehicle-Mounted Computer

The Thor VM1A Vehicle-Mounted Computer (VMC) is a rugged, vehicle mounted computer powered by Android and capable of wireless data communications from a fork-lift truck or any properly configured vehicle. VM1A is built on the Mobility Edge™ platform and can deliver real-time connectivity, advanced data capture, and future-proof investment protection. The computer is equipped for fast Wi-Fi connectivity with a WLAN 802.11 a/b/g/n/ac radio and Bluetooth (v5.0) technology that includes Bluetooth Low Energy (BLE) support.

The computer is designed for use with a vehicle dock. The dock installs in the vehicle, connects to vehicle power, and provides conditioned input power for the computer. The VM1A is designed to be easily removed from the dock and be moved from one vehicle dock to another.



Caution: Before shipping the Thor VM1A, be sure to **Disconnect the UPS Battery**.

VM1A contains a UPS battery which, when fully charged, can power the computer for a minimum of 30 minutes for when the computer is not attached to a dock, is being switched to another dock, or the vehicle power is interrupted.

Model Overview

Available Features
Android operating system, upgradeable through Android 12
2.2 GHz Qualcomm Snapdragon™ 660 octacore processor
4GB SDRAM, 32 GB flash memory
WXGA displays available for indoor and brighter outdoor options
Integrated ambient light sensor, proximity sensor, accelerometer, gyroscope, magnetometer, and pressure sensors
64-key QWERTY keypad
WLAN IEEE 802.11 a/b/g/n/ac radio; Wi-Fi certified
Bluetooth™ V5.0 and Bluetooth Low Energy (BLE) technology support
NFC technology for short-range wireless data exchange
Mid-tier rugged specifications with IP66 sealing
Customer-accessible SD™ slot for removable memory cards up to 512 GB (SDXC/SDHC/SDIO-compliant)

Note: To learn more, see [Specifications and Reference Materials](#) beginning on page 149.

Features of the VM1A

Front View - Thor VM1A

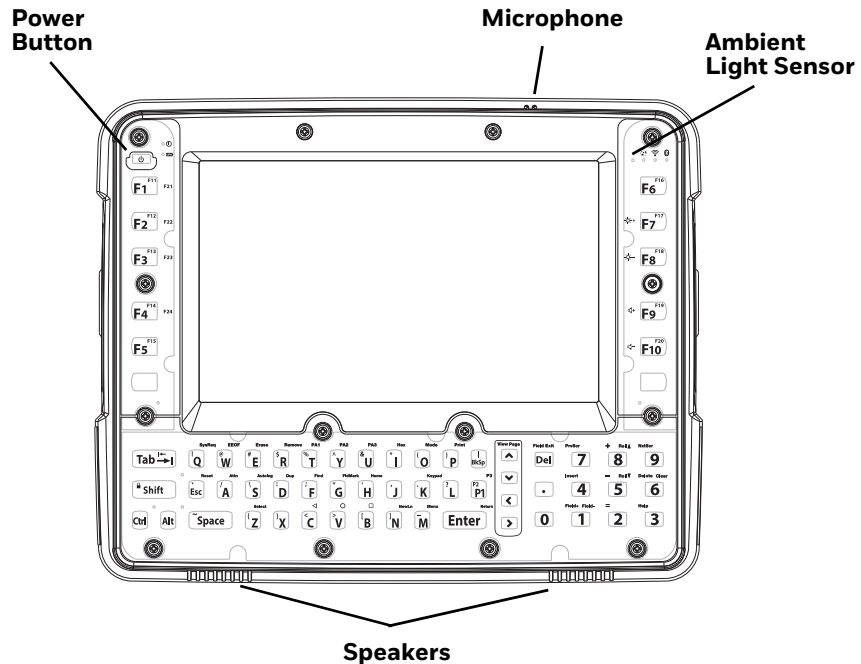

Back View - Thor VM1A

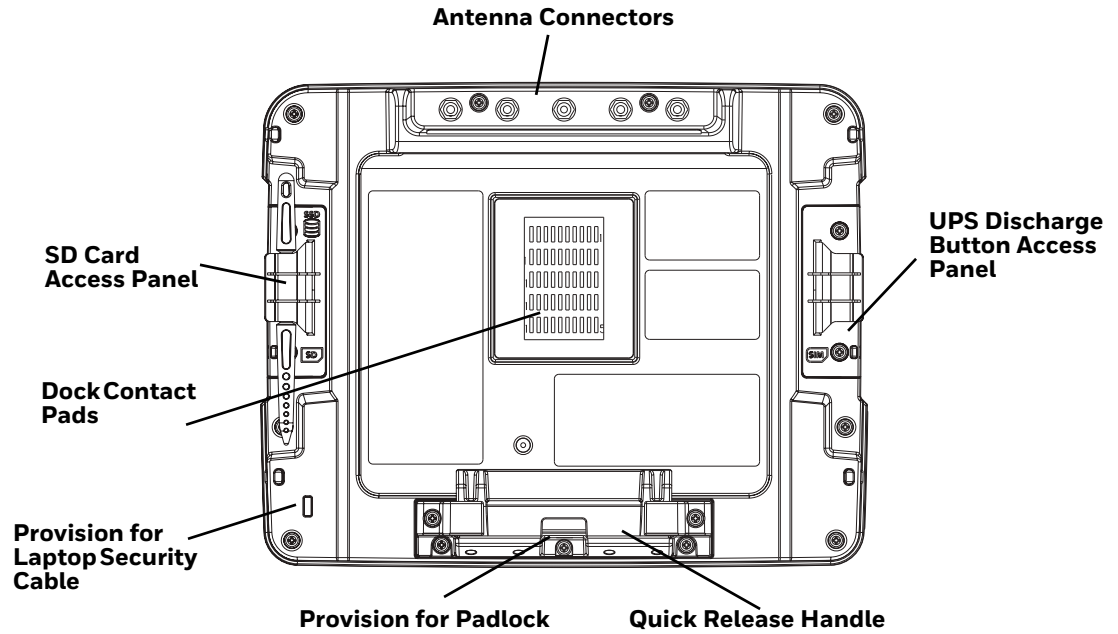

Access Panels - Thor VM1A

SD Card Access Panel with door removed

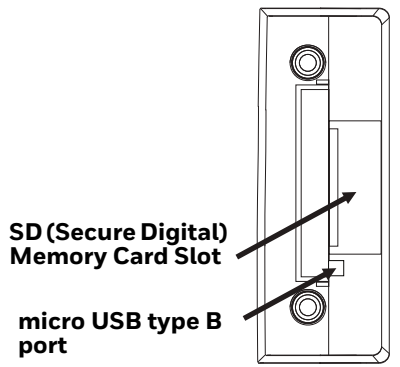

Access Panel Door is labeled with  and .

SIM Access Panel with Door Removed

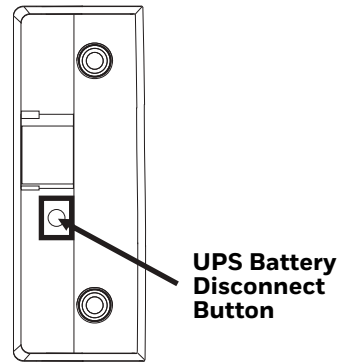

Access Panel Door is labeled with .

Power Management Modes

The Thor VM1A has three power modes: On, Sleep, and Off.

On Mode

When the computer is attached to vehicle power, external power supply, or is operating from the UPS battery and the power button is pressed, the computer is in the On mode. In this mode, the keypad, touch screen, and any attached peripherals, such as a scanner, function normally. The display remains On unless the unit transitions to Sleep Mode or screen blanking is activated.

When in On mode, the status LED is solid green.

Sleep Mode

When the computer enters Sleep mode, all LEDs are off. Sleep mode occurs when the power button is pressed momentarily or the inactivity timer expires.

When in Sleep Mode, the status LED:

- is green, if external power is attached.
- is off, if external power is not attached.

To wake the computer from Sleep Mode, momentarily press the power button.

Off Mode

When the power button is held, an option menu appears, and Power Off is selected.

The computer is also Off when it is not connected to a power source and the UPS battery is depleted. However, an internal Real Time Clock (RTC) powered by an internal battery, maintains the date and time while the computer is Off.

About the Power Supply

Vehicle DC Power Supply

Vehicle power input for the dock is 10V to 60V DC and is accepted without the need to perform any manual operation within the dock, see [12-48 VDC Vehicles \(10-60 VDC Direct Connection\)](#). The dock provides a regulated power output for the VM1A. By using a specified DC/DC power supply, input voltage of 50-150V DC can be accepted, see [60-144 VDC Vehicles \(50-150 VDC Power Supply, Screws on Top of Lid\)](#) or [60-144 VDC Vehicles \(50-150 VDC Power Supply, Screws on Side of Lid\)](#).

Input power to VM1A is fused for protection and the fuse is externally accessible, see [Fuse](#).

External AC Power Supply

If DC power is not available, for example, in an office environment, an optional external Universal Input Power Supply can be used to convert an AC wall outlet to an appropriate DC level. AC to DC power input for the computer is delivered to the dock via an optional external power supply and adapter cable. See [External AC/DC Power Supply](#).

Uninterruptible Power Supply

- The VM1A contains an internal UPS battery backup. The user can [Replace the UPS Battery](#).
- The UPS battery is automatically charged when the computer is placed in a powered dock, provided the [Safe Charging Temperature Range](#) is met.
- When external power is removed, the UPS automatically powers the computer with no user intervention. When running on UPS power, the power management time outs may be different than when vehicle power is applied.
- The UPS allows the computer to continue operation when not mounted in a dock or when the vehicle battery is being swapped. When fully charged, the UPS battery is designed to power the computer for a minimum of 30 minutes at temperatures of 20°C (68°F) or greater.
- If operating on UPS power and the UPS battery becomes critically low, the computer performs a controlled shutdown.
- If there is no external power available, there must be 10% or greater power in the UPS battery or the computer does not power On.
- The UPS status LED and the Battery Control Panel can be used to monitor the status of the UPS battery.



Caution: Safety requirements restrict the temperature at which the Li-Ion UPS battery can be charged. Charging is disabled if the temperature is outside of the 0° to 35°C safe charging range. In order to maintain UPS charge, the Thor VM1A should have power applied while the unit is within the safe charging range for at least an hour each day.

Safe Charging Temperature Range

The internal temperature of the VM1A is the trigger for UPS battery charging.

- The UPS battery is not charged when the internal temperature is below 0°C (32°F). This corresponds to an ambient (room) temperature of approximately -10°C (-14°F).
- The UPS battery is not charged when the internal temperature is above 45°C (113°F). This corresponds to an ambient (room) temperature of approximately 35°C (95°F).

- If the UPS battery cannot be charged due to a temperature extreme, the **UPS Status LED** is amber. Move the VM1A to a different location to charge the UPS battery.

Charging Timeout

- A fully discharged UPS battery normally recharges in less than 4 hours when the computer is in a powered dock and within the safe charging temperature range.
- If the UPS battery is not charged before an 8 hour timeout period expires, the **UPS Status LED** is amber.
- The charge timeout is reset if charging resumes upon application of external power.
- The charge timeout is reset if charging resumes when the computer enters the permissible temperature range for charging.
- If the charge timeout occurs frequently, the UPS battery should be replaced.

Charging and Power Management

Charging of the UPS battery continues when the computer is in power management (Display Off or Sleep mode).

Backup Battery

The Thor VM1A has a permanent Lithium battery installed to maintain time, date, and CMOS setup information for a minimum of 90 days. The lithium battery is not user serviceable and should last five years with normal use before it requires replacement.



Warning: Improper replacement or repair could damage the battery, cause overheating, risk of explosion, and result in injury. The battery should be disposed of properly. The battery should not be disassembled or crushed. The battery should not be heated above 212°F (100°C) or incinerated. The battery must be recycled or disposed of separately from household waste.

Note: *The backup battery should only be changed by authorized service personnel.*

Fuse

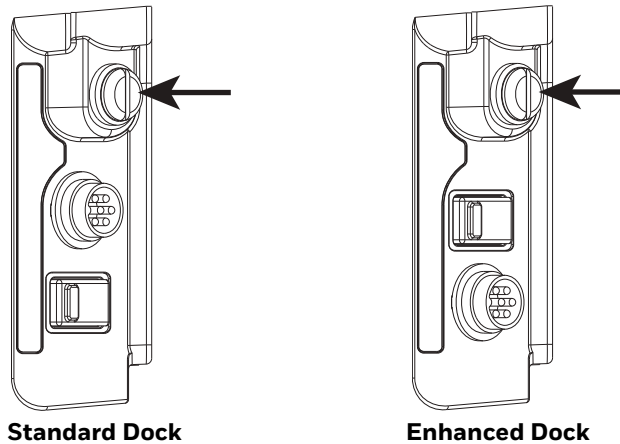

The VM1A uses an 8A time delay (slow blow) fuse that is externally accessible and user replaceable. The fuse is located on the back of the dock and is accessed by unscrewing the cap.

Should the fuse need replacement, replace with similar type or rating of the below fuse specs:

- Littelfuse O215008.MXP,
- Cooper Bussmann BK1/S506-8-R,
- Bel Fuse 5HT 8-R,
- or equivalent.



Caution: Fuse has voltage on it even when power is Off. Always disconnect input power before changing the fuse.

Disconnect the UPS Battery



Caution: The UPS battery must be disconnected before you ship the Thor VM1A, [Replace the UPS Battery](#), or [Replace the Front Panel](#).

Equipment Required

The following equipment is user-supplied:

- Torque tool capable of measuring inch pounds
- #2 Phillips screwdriver bit

Disconnect Procedure

1. For convenience, the VM1A can be removed from the dock, though it is not necessary. If the VM1A remains in the dock, disconnect the power cable from the dock.
2. Press and hold the **Power** button until the options menu appears. Tap **Power Off**.
3. If the computer was removed from the dock, place the computer face down on a stable surface.
4. Using a #2 Phillips bit loosen the M3 screws and then remove the tethered access panel with the SIM label.

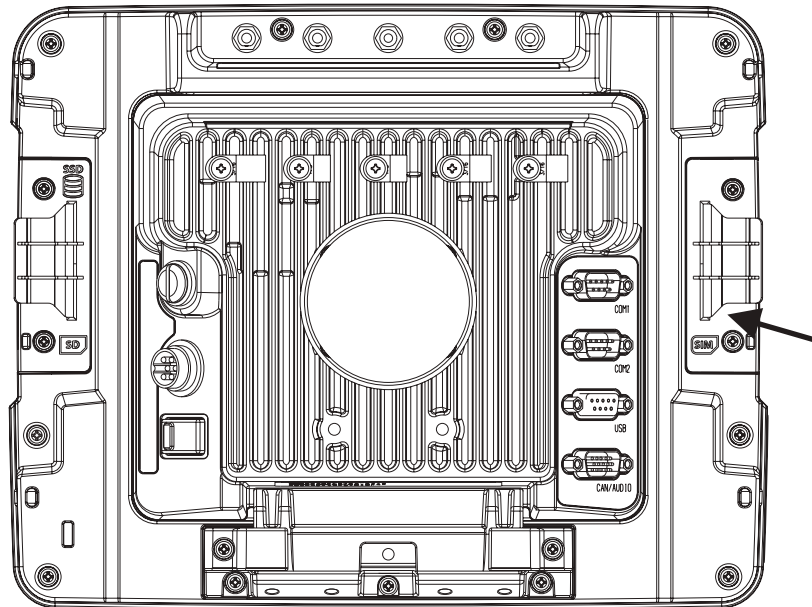

5. Locate the small push button.

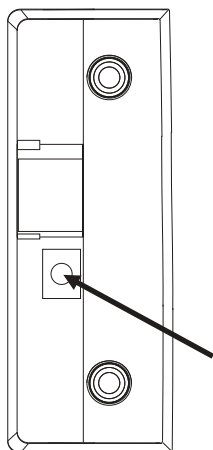

6. Press the push button to disconnect the UPS. The UPS battery maintains its charge but is disconnected from the power circuitry of the computer.

7. Reattach the access panel, torque the M3 screws to 4-5 inch pounds using a #2 Phillips bit.
8. When the computer is attached to external power, the UPS battery is automatically reconnected.
9. Press the **Power** button to turn on the computer.

Replace the UPS Battery

The UPS battery in the VM1A is field replaceable. Should the UPS battery fail, it can easily be replaced to minimize downtime.

Equipment Required

The following equipment is user-supplied:

- Torque tool capable of measuring inch pounds
- #2 Phillips screwdriver bit

Replacement Procedure



Caution: Before replacing the Thor VM1A front panel, **Disconnect the UPS Battery.**

1. Place the VM1A on a clean, well-lit surface before performing the UPS battery replacement.
2. Press and hold the **Power** button until the options menu appears. Tap **Power Off**.
3. Remove the computer from the dock.
4. **Disconnect the UPS Battery.**

5. Loosen the fourteen (14) captive M3 screws holding the front panel. Use a #2 Phillips bit.

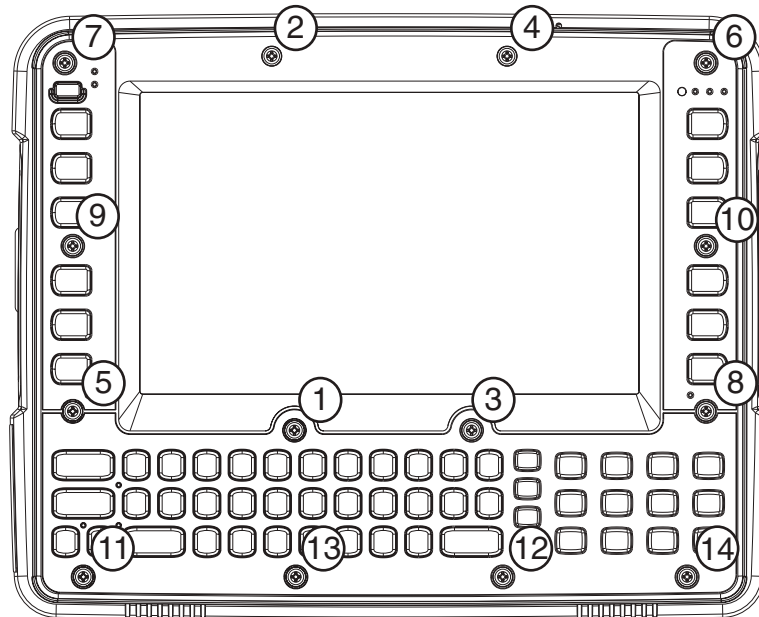

6. Carefully lift the front panel away from the device.
7. Note the orientation of the UPS battery. Lift the UPS battery out of the battery well and place it outside the well. Do not pull on the wires attaching the battery to the computer while lifting the battery.

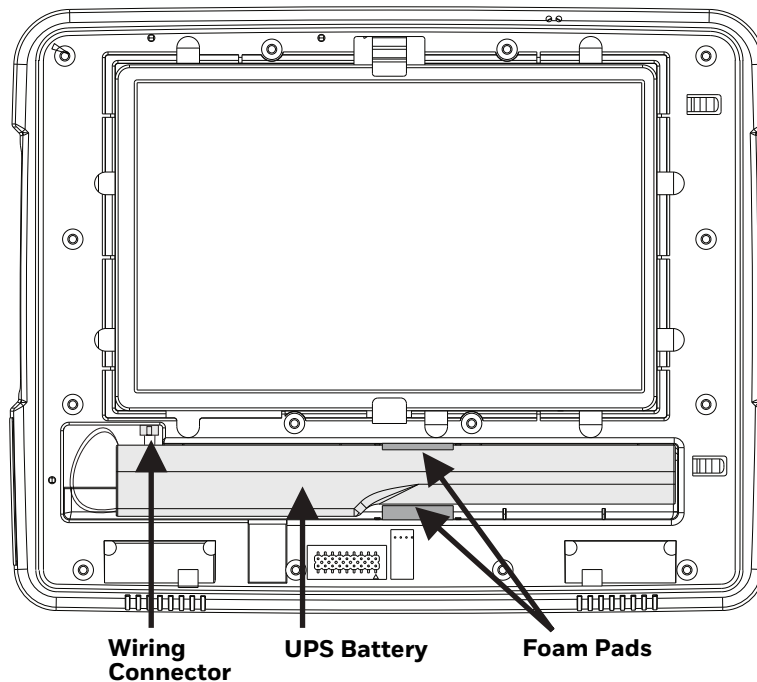

8. Locate the retaining tab on the wiring connector for the UPS battery. Press on the tab and gently disconnect the UPS battery wiring.

9. Remove the old battery and set it aside.
10. Inspect the battery well to verify the two foam pads are still in place.
11. Align the wiring connector on the new UPS battery with the connector on the computer. Gently press the connector into place until the retaining tab snaps into place.
12. Place the UPS battery into the well. Note the orientation of the battery in the illustration below. The flat surface of the battery points toward the bottom of the VM1A. Make sure all wires are inside the battery well so they are not pinched when the front panel is reinstalled.

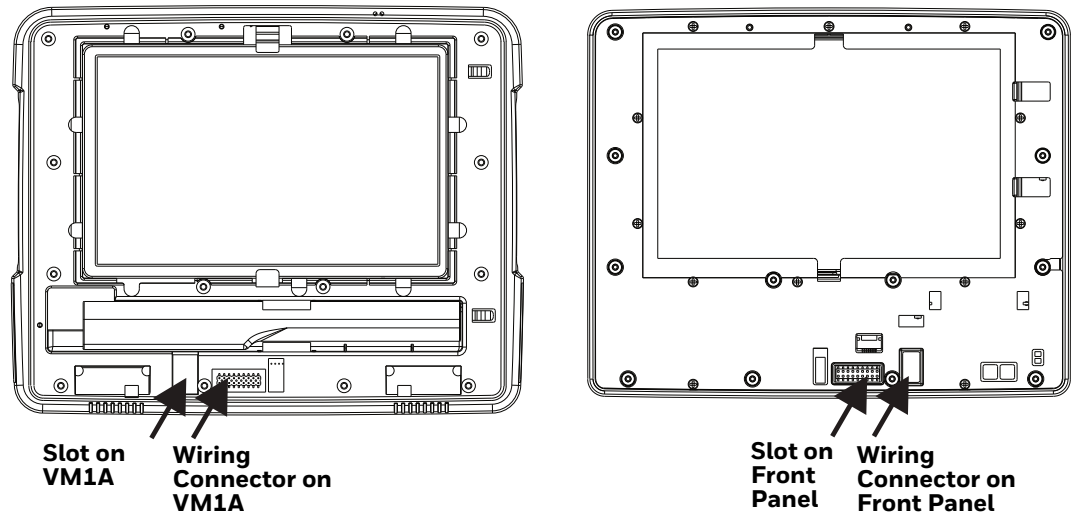







13. Position the front panel so the tab on the back of the front panel lines up with the slot on the VM1A. Be sure the two wiring connectors are also aligned.
14. Gently press the front panel into place.
15. Tighten the fourteen (14) captive M3 screws. In the order shown in step 5, use a #2 Phillips bit and torque the screws to 6-7 inch pounds.
16. Reinstall the computer in the dock.
17. When the computer is placed in the powered dock, the UPS battery automatically reconnects. The UPS battery automatically begins charging from the powered dock.
18. Press the **Power** button to turn on the computer.

About the Battery Status

Use the battery icon in the Status bar to see the charge level of your battery. If you want more detailed information on your battery, such as usage time, charge remaining on the battery, or battery health information, open the

Settings app  and tap **Battery**.

Battery Status Icons

Icon	Status
	The battery charge is at 100%.
	The battery charge is at 50%.
	The battery charge is low. You need to charge the battery soon.
	The battery is critically low. You need to connect the computer to a dock.
	The computer is connected to the dock and the battery is charging.
	There is a battery error.

Check the Battery Level and Usage

In addition to the Battery status icon and LED, you can monitor the battery status from the Settings app.

1. Swipe up from the bottom of the Home screen to access all apps.
2. Tap **Settings**  > **Battery**.

The current percentage of battery power remaining and the amount of usage time left on the battery appear on the screen. A list shows the battery usage for individual apps and services. For usage details, select one of the apps or services in the list. You can also access the Battery saver feature from the battery screen.

Enable Airplane Mode

If you do not need to connect to any wireless networks, you can enable Airplane mode to turn Off the radios and save battery power.

1. Swipe up from the bottom of the Home screen to access all apps.
2. Tap **Settings** .
3. In the **Network & internet** section, tap the toggle button next to **Airplane mode**. An airplane icon appears in the status bar to indicate Airplane mode is turned On.

Power On the Computer



Caution: If a USB drive, such as a thumb drive, is attached to the Thor VM1A, the device will attempt to boot from the USB drive. Remove the USB drive and power up the computer again.

The dock has a power switch on the back. The “On” side of this rocker switch has a raised bump to allow the state of the switch to be determined when the switch may not be easily viewed, for example, after the dock is mounted in a vehicle.

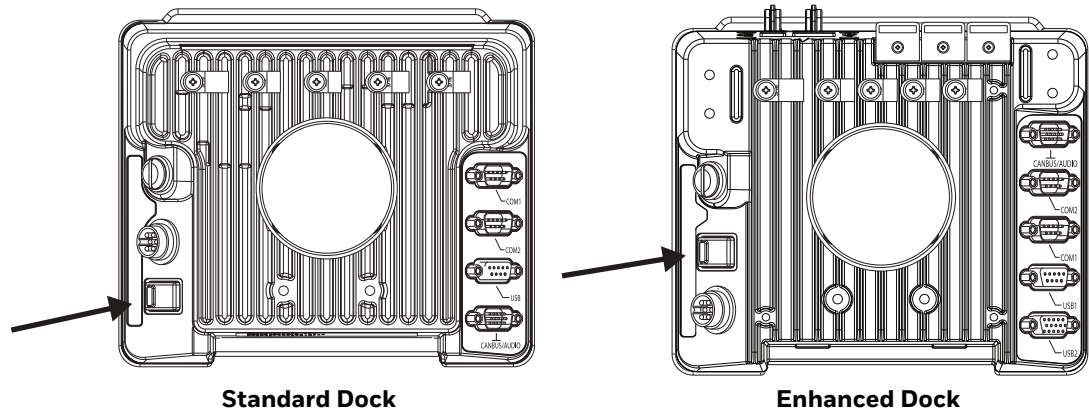

After external power has been connected and the computer has been mounted in the dock, press the side of the power switch with the raised bump to pass power from the dock to the computer.

Next locate the **Power** button on the front of the VM1A.

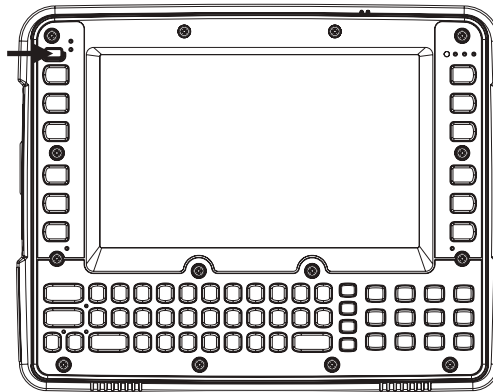

Press the power button to turn the computer On. When the Welcome Screen is displayed or an application begins, the power up sequence is complete.

After initial power On, the computer can be configured to automatically power On. See [Power Management Modes](#) for more information.

Power Cable Cautions



Caution: When routing the power cable:

- Route power cable away from the outside of the fork truck.
- Choose a mounting location so that the power cable does not extend outside the vehicle and that provides sufficient clearance so that the power cable (especially the dock connector end) is not pressed against part of the vehicle.
- Use the proper [Strain Relief Cable Clamps](#) to secure cable.
- The power cable is less flexible in low temperature environments. Avoid sharp bends.



Caution: Regularly inspect power cable for damage, especially in low temperature environments. Contact [Technical Assistance](#) for replacement cable options.

Power Cable Routing

Power cable with right-angle connector

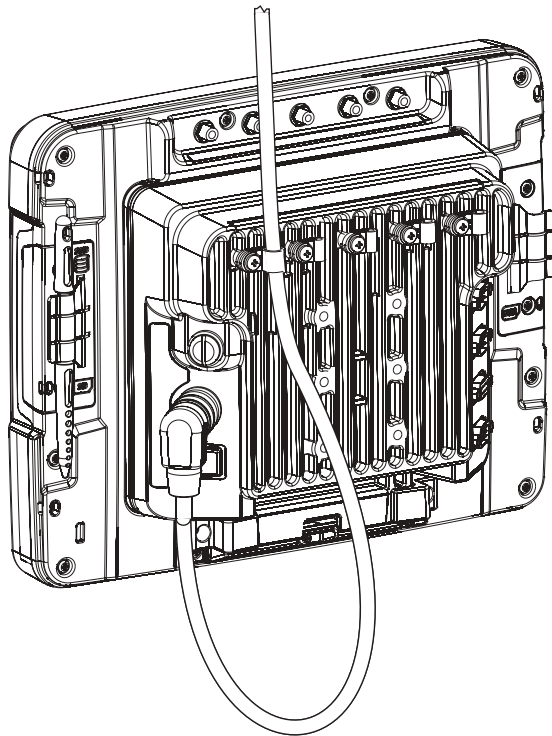

Power cable with straight connector

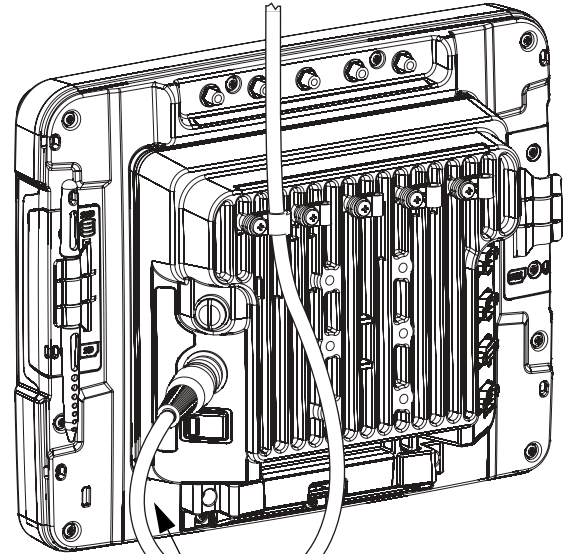

Avoid sharp bends in this area of the power cable

Power Mode

Select the desired power mode behavior.

1. Swipe up from the bottom of the Home screen to access all apps.
2. Tap **Settings**  > **Honeywell Settings** > **Power Mode**.
3. Choose one of the following options:
 - **AC/DC**
 - **Auto-On**
 - **Ignition Control**
 - **UPS**
4. Select Power Schedule for **Sleep** and **Shutdown**.

AC/DC

The computer is turned On and Off manually by the user using the power button on the front of the device.

Ignition Control

The computer is turned On automatically when a signal is received via the Ignition Input wire, which is part of the DC Power Cable.

Auto-On

The computer automatically powers up when power is provided. Auto-On is recommended when the VM1A is powered by AC. The computer will automatically power up after a power outage.

UPS

The computer is turned On or Off manually by the user using the power button on the front of the device. The computer will shutdown automatically after one hour of inactivity.

Power Schedule

Set the duration of time to put the VM1A into Sleep Mode or Shutdown.

Note: *The device will sleep or shutdown after the timeout of inactivity.*

Welcome Screen

The first time you power On the computer, a Welcome screen appears.

During the manual setup process, follow the prompts on the screen as the wizard has you:

- Set the default language.
- Set up the Wi-Fi network connections.
- Set the time, date, and time zone.
- Personalize (name) the computer.
- Set up security and privacy options.
- Calibrate the touch screen (not required for PCAP touch screen).

Once you complete the initial setup, the Welcome screen no longer appears when you power on the computer and Provisioning mode (see page 62) is automatically turned off (disabled).

Touch Screen Calibration

1. Swipe up from the bottom of the Home screen to access all apps.
2. Tap **TouchScreen Calibration**.
3. Choose one of the following options:
 - **Draw Test**
 - **4 Points Calibration**
 - **9 Points Calibration**
 - **25 Points Calibration**
 - **Reset Parameter**
 - **About**
4. Follow the on-screen prompts to touch the targets, hold and then lift the stylus to complete the calibration process.

Note: *Touch screen calibration is not necessary with the optional Projective Capacitive (PCAP) touch screen.*

Unlock the Screen

The screen lock automatically activates every time the computer is turned On or when the computer wakes from sleep mode.

- Swipe up from the lock icon at the bottom of the screen.

The level of security provided depends on the type of lock set (e.g., Swipe, Pattern, PIN, or Password). The default setting (Swipe) provides no protection against unauthorized access to your computer.

Change the Screen Lock to Protect the Computer

After you start using the computer, you should change the screen lock to prevent unauthorized persons from accessing the computer without a password, pin, or pattern to unlock the touch screen once it has been locked.

The recommended setting for the Screen Lock is to enable a Password lock. Use a strong password value (e.g., include numbers, characters, special characters, and mix character case).

1. Swipe up from the bottom of the Home screen to access all apps.
2. Tap **Settings**  > **Security** > **Screen lock**.
3. Choose one of the following options:
 - **None**
 - **Swipe**
 - **Pattern**
 - **PIN**
 - **Password**
4. Follow the on-screen prompts to complete the setup.
5. Exit the Settings app.

Configure the Screen Backlight

The display has an ambient light sensor that automatically adjusts the backlight intensity to conserve power and ensure the display is readable. You can also manually set the backlight intensity if you do not want to use the automated adaptive brightness feature.

1. Swipe up from the bottom of the Home screen to access all apps.
2. Tap **Settings**  > **Display**.
3. Choose one of the following options:
 - To have the computer automatically adjust the brightness for your work environment, turn on the **Adaptive brightness** setting. You can tap **Adaptive brightness** to toggle the feature on or off.

- To set the brightness level manually, verify the **Adaptive brightness** feature is turned Off, and tap **Brightness Level**. Adjust the slider to set the brightness level.

To set the brightness level manually, verify the Adaptive brightness feature is turned off, and tap **Brightness level**.

- Use the **Blue Key + F7** keypress to increase backlight brightness.
- Use the **Blue Key + F8** keypress to decrease backlight brightness.

Screen Blanking

Screen blanking (blackout) can be enabled when the vehicle is in motion. Once screen blanking is enabled, the display is blanked out (or a preselected zoom area is displayed) any time when the vehicle is in motion. If the screen blanking cable is removed, screen blanking is disabled and the display remains On.

1. Swipe up from the bottom of the Home screen to access all apps.
2. Tap **Settings**  > **Honeywell Settings** > **Zoomzone**.

Motion Detection Action

Determine what to do when motion is detected:

- **Display Always Active** - The display does not change when motion is detected.
- **Display Black** - The display is blanked out when motion is detected.
- **Display Freeze** - The display is frozen at the time motion is detected.
- **Zoom Zone** - A preconfigured zoom area is displayed when motion is detected.

Motion Timeout Settings

Screen blanking can be configured to provide delays.

- **Delay on Motion** - Configure the delay between motion detection and screen blanking. The default is 2 seconds.
- **Delay on Stop** - Configure the delay between motion stopping and the screen resuming normal behavior. The default is 2 seconds.

Motion Detection Source

Select the Motion Detection Source. The computer supports the screen blanking box to determine motion.

Select the port (COM1 or COM2) the blanking box is attached.

Zoom Zone

Set Zoom Area

The Zoom Area can be selected from the current active desktop display. To set the zoom area:

1. Display the desired content on the VM1A desktop.
2. Open the Screen Blanking interface.
3. Select **Zoom Zone** in Motion Detection Action.
4. Tap the **Set Zoom Area** button.
5. Select the desired zoom area by tapping on the upper left corner of the desired area and dragging to the lower right corner of the desired area. The selected area is highlighted by a red outline.

Note: *Be sure to select the desired area from the upper left corner to the lower right. Selecting the area from a different corner may result in nothing (a black box) being displayed.*

6. If the selected area is not satisfactory, repeat the step above to reselect an area.
7. To save, tap the check mark in the upper right corner.

Show Zoom Area

Tap the **Show Zoom Area** button to show the currently selected zoom area. The selected area is highlighted in red.

When finished, tap the back button .

Test Zoom Area

Tap the **Test Zoom Area** button.

- The zoom image is displayed.

About the Keypad

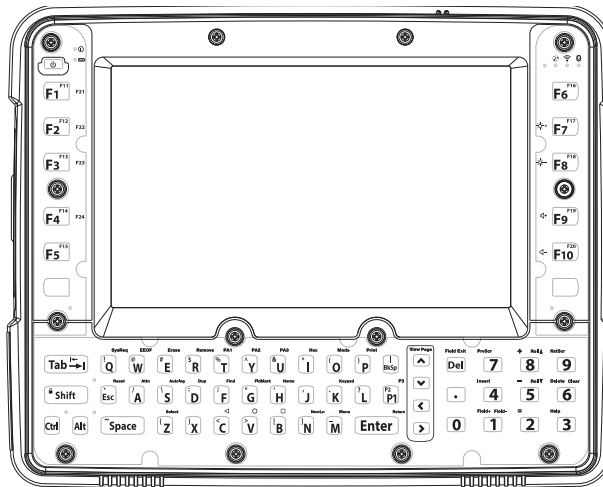

The keyboard keys are backlit.

- Standard ANSI key labels are printed on the keys. Some commands, 5250 and 3270, are printed above the keys and are accessed by pressing either the blue or orange keys first. For keypress order, see [Keypad Key Map](#).
- By default, the keyboard backlight follows the display backlight. When the display backlight is On, the keyboard backlight is On.
- If the display backlight brightness is increased (or decreased) the keyboard backlight brightness is increased (or decreased).

The keyboard backlight and the display share the same timer. To configure the backlight, see [Configure the Screen Backlight](#).

Keyboard Options

The Orange, Blue, ALT, CTRL, and Shift key are sticky keys. The [Keyboard LEDs](#) identify the active sticky modifier mode state of the keyboard.

USB Keyboard/Mouse

A standard USB keyboard or mouse can be attached to the computer using the appropriate adapter cable.

The VM1052CABLE USB Y cable attaches to the dock and provides a type A USB connector.

Keyboard LEDs

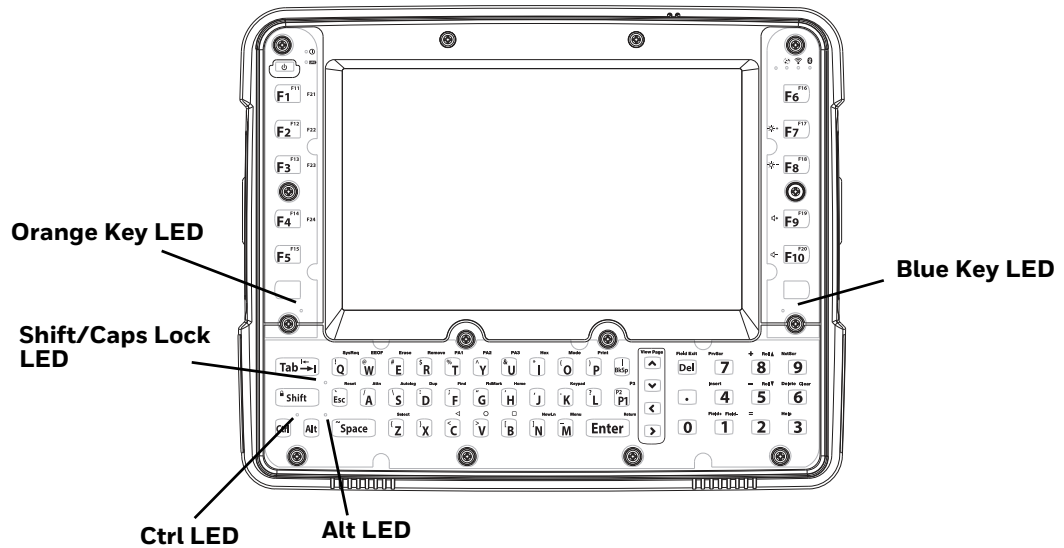

The keyboard LEDs are located near the specified key.

Blue Key LED

LED Behavior	Status
Solid Blue	<ul style="list-style-type: none"> Indicates the Blue Key modifier key is active. Blue Key mode is invoked for the next keypress only. Pressing the Blue Key a second time exits this modifier mode and turns off the LED.
Off	Blue Key mode is not involved.

Orange Key LED

LED Behavior	Status
Solid Red	<ul style="list-style-type: none"> Indicates the Orange Key modifier key is active. Orange Key modes in invoked for the next keypress only. Pressing the Orange key a second time exits this modifier mode and turns off the LED. Pressing the Orange key followed by the Shift key places the system in Caps Lock mode. To exit Caps Lock mode, press the Shift key again.
Off	Neither Orange Key or Caps Lock mode is invoked.

Shift LED

LED Behavior	Status
Solid Green	<ul style="list-style-type: none">Indicates the keypad is in Caps Lock mode. Caps Lock mode is invoked until canceled.Pressing the Orange key followed by the Shift key places the system in Caps Lock mode.To exit Caps Lock mode, press the Shift key again.
Off	Neither Shift or Caps Lock mode is invoked.

Ctrl LED

LED Behavior	Status
Solid Green	<ul style="list-style-type: none">Indicates the Ctrl modifier key is active. Ctrl mode is invoked for the next keypress only.Pressing the Ctrl key a second time exits this modifier mode and turns off the LED.
Off	Ctrl mode is not invoked.

Alt LED

LED Behavior	Status
Solid Green	<ul style="list-style-type: none">Indicates the Alt modifier key is active. Alt mode is invoked for the next keypress only.Pressing the Alt key a second time exits this modifier mode and turns off the LED.
Off	Alt mode is not invoked.

System LEDs

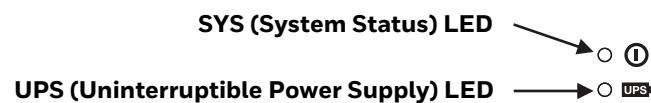

SYS (System Status) LED

LED Behavior	System State
Solid White	<ul style="list-style-type: none">OnOn, but in Sleep Mode
Blinking White	<ul style="list-style-type: none">CPU temperature is less than -20°C. The unit must be moved to an environment warmer than -20°C before it will boot up.

LED Behavior	System State
Off	• Off

UPS Status LED

The behavior of the UPS LED depends if external power is connected or not.

External Power Present

LED Behavior	Status
Solid Green	UPS is more than 50% charged
Solid Amber	UPS is less than 50% charged
Blinking Red	Battery error

External Power Not Present

LED Behavior	Status
Blinking Green	UPS is more than 30% charged
Blinking Amber	UPS is less than 30% charged
Off	Unit is off

Connection LEDs

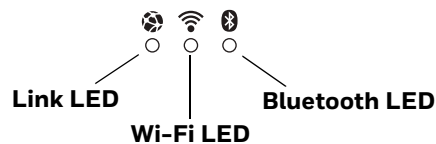

Link LED

LED Behavior	Status
Solid Green	Indicates a connection to Host. By default, the Link LED is disabled.
Blinking Green	Indicates a ping response has been received within five times of the user specified response time.
Off	Indicates no connection to Host.

Wi-Fi LED

LED Behavior	Status
Solid White	Indicates a connection with an IP address to an Access Point.
Off	Indicates no connection to an Access Point.



Bluetooth LED

LED Behavior	Status
Solid Blue	Bluetooth is paired and connected to a device.
Blinking Blue	Bluetooth is discovering and connecting to Bluetooth devices.
Off	Bluetooth hardware has been turned off.

About the Audio Features

The computer has speakers, a microphone, and several software tools to configure sound volume.

Adjust Speaker Volume

1. The speaker volume can be adjusted via the keypad:
 - Use the **Blue Key + F9** keypress to increase speaker volume
 - Use the **Blue Key + F10** keypress to decrease speaker volume
2. The volume slider appears.
3. Depending on the OS version, tap the down arrow  or  to expand the options.
4. Use the stylus or the Volume buttons to adjust each volume type.

Audio Settings

This section describes the audio and sound settings you can configure in the Settings app.

- To change audio settings, start the **Settings** app  and tap **Sound**.

Sound Settings

Note: Phone calls are not supported with VM1A.

Setting	Description
Cast volume Media volume Ring & notification volume Alarm volume	Use the sliders to set the volume for media (e.g., music, videos, and games) and alarms.
Do Not Disturb	Set app priority allowances, block visual disturbances, and set automatic rules.
Shortcut to prevent ringing	Press Power & Volume Up together. Options include: Vibrate or Mute.

Setting	Description
Default notification sound	Select a notification sound.
Default alarm sound	Select a alarm sound.
Other sounds and vibrations	
Dial pad tones	Enable or disable an audio tone when you touch the numbers.
Advanced	
Screen locking sounds	Enable or disable an audio tone when the screen is locked.
Charging sounds and vibration	Enable or disable an audio tone when the computer is charging.
Touch sounds	Enable or disable audio sounds when you use the touch screen.

About the Defroster

Thor VM1A comes equipped with LCD window defroster to support extended use in freezers as well as transitions into and out of freezer areas.

The defroster can be set to:

- **Automatic**
Turn On automatically to defrost the window based on external temperature changes and timers.
- **Manual**
The user can control the defroster by manually turning it On or Off.

Automatic mode

This is the default mode of operation for the defroster. The defroster activation is controlled by the specifications entered by the user. When the temperature of the computer is below the Defroster enable temperature, the defroster will turn On. The defroster will turn Off after the temperature is reached.

How Automatic Mode Works

Automatic defroster management saves power since the defroster is automatically controlled by the system based on Defroster enable temperature. Automatic mode is enabled by default.

Turn the Defroster On/Off in Automatic Mode

1. Swipe up from the bottom of the Home screen to access all apps.
2. Tap **Settings**  > **Defroster**.
3. Tap the **Automatic/Manual** button to switch between the Automatic or Manual mode. The active mode appears on the button. When Automatic mode is enabled, the Defroster Off button is not active.

4. Select the desired Defroster enable temperature.

Manual mode

When enabled, defroster activation is controlled solely by the user. No temperature monitoring and timers are used to control the defroster. The user must manually turn the defroster On or Off.

How Manual Mode Works

Manual mode gives you full control over turning the defroster On or Off. When Manual mode is enabled, automatic mode no longer used to control the defroster's behavior. To turn the defroster on/off, you must tap a button on the Defroster screen in the Settings app. Manual mode is disabled by default.

Turn Manual Mode On/Off

1. Swipe up from the bottom of the Home screen to access all apps.
2. Tap **Settings**  > **Defroster**.
3. Tap the **Automatic/Manual** button to switch between the Automatic or Manual mode. The active mode appears on the button. When Manual mode is enabled, the Defroster On/Off button is active.
4. Tap the **Defroster On/Off** button to control the defroster.

Configure the Defroster in the Settings App

1. Swipe up from the bottom of the Home screen to access all apps.
2. Tap **Settings**  > **Defroster**.
3. Modify the defroster parameters.
4. Tap **Update** to apply the changes.
5. Tap **OK**.

Defroster Parameters

You can configure the following **Defroster** parameters in the **Settings** app to fit your specific application environment.

Defroster Setting	Description
Defroster	Enable or Disable the Defroster feature and temperature monitoring. Tap the switch button at the top of the screen to toggle the feature On or Off. The default is On.

Defroster Setting	Description
Defroster enabled temperature	Set the temperature (°C) that the computer must fall to before the system determines cold storage entry and defroster use.
Defroster State	Shows current state of defroster, On or Off .
Temperature	Shows detected LCD window temperature
Manual/Automatic	Tap the button to switch between Automatic mode or Manual mode. To learn more about the modes, see How Automatic Mode Works on page 25 and Manual mode on page 26.
Defroster On/Off	Tap the button to switch between On and Off .

Insert an SD Card

You can use an SD card to increase file storage capacity or to install software. Honeywell recommends the use of Single Level Cell (SLC) industrial grade SD or SDHC memory cards with the computer for maximum performance and durability.

Note: *Format the memory card before initial use.*

Equipment Required

The following equipment is user-supplied:

- Torque tool capable of measuring inch pounds
- SD card up to 512 GB
- #2 Phillips screwdriver bit

Installation Procedure

1. For convenience, the computer can be removed from the dock, though it is not necessary. If the computer remains in the dock, disconnect the power cable from the dock.
2. Press and hold the **Power** button until the options menu appears. Tap **Power Off**.
3. If the computer was removed from the dock, place the computer face down on a stable surface.
4. Using a #2 Phillips bit loosen the M3 screws and then remove the access panel with the SD label. This panel is on the left hand side when the computer is face down with the top away from the user.

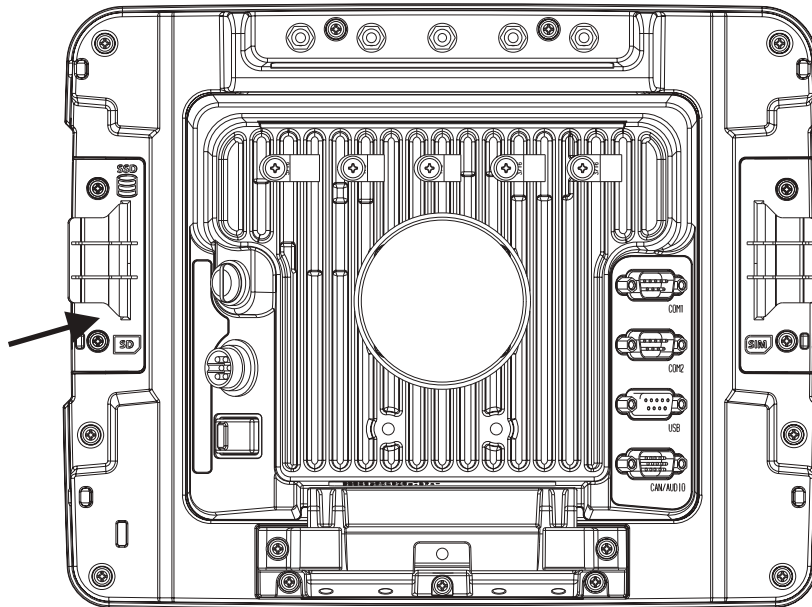

5. Locate the SD card installation slot.

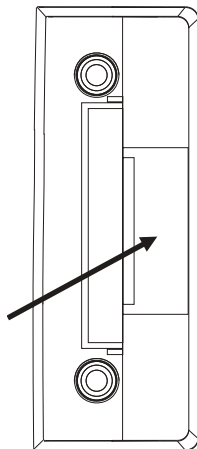

6. Slide the SD card into the slot. The label side (front) of the SD card faces toward the back of the computer.
7. Reattach the access panel, torquing the screws to 4-5 inch pounds.
8. If removed, reinstall the computer in the dock.
9. Press the **Power** button to turn on the computer.

Scanners

VM1A supports external scanners through USB, Serial Port, and Bluetooth.

For more information:

- [Connect a Bluetooth Scanner](#) for connecting Bluetooth Scanners
- [Connect a Tethered Scanner](#) for connecting a scanner through the serial port
- [USB Scanner](#) for connecting a scanner through USB

ABOUT THE USER INTERFACE AND APPLICATIONS

Use this chapter to learn about the user interface and how to interact with the screen. You can also use this chapter to learn about the Honeywell applications on the computer.

About the User Interface

The Android operating system provides a touch-friendly and easy-to-navigate user interface. When you turn On the VM1A, the Home screen is the first screen that appears after language provision and the startup Wizard is complete.



– Notification / Status Bar

– Search Bar

– HomeScreen Panel

– Swipe up from the bottom of the screen to access all apps

– Favorites Tray

– Virtual Navigation Buttons

Home Screen Features



Item	Description
Notifications panel / Status bar	Status icons to the left tell you when an app has sent notifications, such as an arriving message. System icons to the right display the current wireless and network connection state and battery level.

Item	Description
Search bar	Search the Internet or the computer using Google™. Touch the microphone icon in the search box to initiate a voice search or command.
Home Screen Panel	You can create more than one custom Home screen panel. Swipe left or right on the Home to switch between your custom panels.
Favorites tray	App icons in the customizable tray are visible on all Home screen panels.

Navigation Buttons

Your computer has virtual buttons on the front panel below the Favorites tray for easy navigation and quick feature access when using the computer.

Navigation Buttons

Button	Description	
	Back	Return to the previous screen.
	Home	Return to the Home screen.
	Recent Apps	View and switch between recently used apps.









To access the navigation buttons on the keypad:





- Use the **Blue Key + C** keypress to return to the previous screen.
- Use the **Blue Key + V** keypress to return to the Home screen.
- Use the **Blue Key + B** keypress to view and switch between recently used apps.

About Status Bar Icons

Status and notification icons show you the current status of your network, the battery, notifications, and sounds. Use the table below to understand some of the most common icons.

Status and Notification Icons

Icon	Description	Icon	Description
	Pending alarm and Alarm is set		Airplane mode is turned On.
	New email		Bluetooth is turned On.
	Computer is connected to a PC with a USB cable		SD card is full
	Synchronizing data		Error with sync or sign-in

Icon	Description	Icon	Description
	Wi-Fi network connected with full signal strength		Wi-Fi network connected but no signal strength
	Computer is connected with Ethernet		Zoomzone is running

Remap a Button or Key

You can change the default function of the physical buttons and keys.

1. Swipe up from the bottom of the Home screen to access all apps.
2. Tap **Settings**  > **Honeywell Settings** > **Keyremap**.
3. Tap the plus sign (+).
4. Press the button or key you want to remap.
5. Tap **OK**.
6. Select one of the following options:
 - Tap **Keys** to view available functions. Select the function you want assigned to the button.
 - Tap **Apps** to view available applications. Select the application you want assigned to the button.
 - Tap **Actions** to enter an Intent or Broadcast. Tap **OK** to assign the action to the button. For example, to send a Broadcast, `android.intent.action.MASTER_CLEAR`, or to start an Intent, `com.android.settings/com.android.settings.wifi.WifiSettings`.
 - Tap **Command** to enter a command that will be executed when the button is pressed. This option supports all ADB shell commands. For example, if you choose a button to remap and enter the command “input keyevent 64”, pressing the selected button will open the web browser on the device.
 - Tap **Text** to type characters to display when the remapped key is pressed. Use a comma “,” to separate the characters. Tap **OK** to assign the text to the button. Examples are listed below:



Input Text	Button Press
A,A,B	aab
SHIFT_LEFT,A,SHIFT_LEFT,B or CAPS_LOCK,A,CAPS_LOCK,B	AB
SHIFT_LEFT,1	!
CTRL_LEFT,A	(Select All)
VOLUME_UP	(Volume Up)

Note: Lower case text is not supported in the **Text** field. Text must be entered in upper case. For example, “H,e,l,l,o” will display as “h”, whereas “H.E.L.L.O” will display as “hello”.

7. The function you selected now appears next to the button or key name.

Restore Default Button Action

To restore the button default action:

1. Swipe up from the bottom of the Home screen to access all apps.
 2. Tap **Settings**  > **Honeywell Settings** > **Keyremap**.
 3. Tap the clean icon .
 4. Choose the remapped button(s) you want restored to the default setting.
 - Tap the check box next to the button.
- OR
- Tap **All Select** to choose all the buttons.
5. Tap **Delete**.

View and Manage Notifications

You can view recent events on the computer, manage system notifications, change a setting, or quickly respond to an app notification by opening the notifications panel.

When a notification icon appears in the status bar at the top of the screen:

1. Swipe down from the top of the screen to open the notifications panel.
2. Respond to the notification. You can take one of the following actions:
 - Tap the notification to open the associated app.
 - Tap a quick-reply or action command (e.g., Reply, Archive) if available.
 - Swipe the notification sideways, off the screen to dismiss it. Note that some notifications cannot be dismissed.
 - Slide the notification left or right to reveal the settings icon . Choose between **Alerting**, **Silent**, or **Turn off notifications**.

To close the notification panel, swipe up from the bottom of the screen, or tap the Back or Home buttons.

Open Quick Settings

Use the Quick Settings screen to quickly access common settings. Tap an icon to toggle the feature on/off or to open additional settings.

- To open Quick Settings, swipe down twice from the status bar at the top of the screen.
- To close Quick Settings, tap the top of the screen, Back or Home buttons.

Customize the Home Screen

You can add application icons to any Home screen for easier access.

1. Swipe up from the bottom of the Home screen to access all apps.
2. Tap and hold the app you want to add.
3. Drag and drop the app icon into place.
 - If you want to add another home screen, drag the icon to the right edge of the screen before releasing the icon.
 - If you want to create a folder, drag and drop the icon on top of another icon.

To add widgets or customize the look of the Home Screen:

1. Tap and hold an empty section of the Home screen.
2. Select either **Wallpapers**, **Widgets**, or **Home Settings**.

Customize the Favorites Tray

Modify the Favorites tray to contain the apps you use the most.

1. Tap and hold the app icon you want to replace on the Favorites tray.
2. Drag and drop the app on “**X Remove**” at the top of the screen.
3. Swipe up from the bottom of the screen to access all apps.
4. Tap and hold the icon of the app you want to add.
5. Drag and drop the icon into position on the Favorites tray.

Use Google™ Search

Use the Google Search field on the Home screen to help you find anything you need on the computer or on the web.

1. On the Home screen, tap inside the Google Search box and begin to type your search term.

As you type, suggestions from Google web search appear below the Search box, and results from the computer (such as apps or contacts) appear below the web search results.

2. Tap a suggestion to search for it immediately, or touch the arrow to add the term to the search field without starting to search.

About Screen Gestures

Use the stylus to manipulate icons, buttons, menus, the on-screen keyboard, and other items on the screen.

- **Tap**

Tap to select something, toggle a setting on or off, or activate a field for text entry. An on-screen keyboard automatically appears for text entry.

- **Tap and hold**

Tap and hold an item but do not lift the stylus until an action occurs.

- **Drag and drop**

Tap and hold an item, and then slide your stylus across the screen until you reach the target position. Lift your stylus off the screen to drop the item in place.

- **Swipe**

Quickly move your stylus across the screen, without pausing when you first touch. For example, you can swipe a Home screen left or right to view the other Home screens.

- **Slide**

Slowly move your stylus across the screen, without pausing when you first touch. For example, you can slide a notification to the left until the Settings gear is revealed.

- **Double-tap**

Tap quickly twice on a web page, map, or other screen to zoom in. Double-tap again to zoom out.

Set the Time Zone

The computer gets the current date and time from its network connection. If preferred, you can change this behavior and manually set the time zone for your location.

1. Swipe up from the bottom of the Home screen to access all apps.
2. Tap **Settings**  > **System** > **Date & time**.
3. Tap **Set time automatically** to turn off the feature.
4. Tap **Time zone** and choose the time zone for your location.

Set PCAP Touch Screen Sensitivity Mode









To set the PCAP touch screen sensitivity press the **Blue Key + F6** to toggle between **Normal Mode** (stylus/finger/light glove) and **Thick Glove Mode**.





About Honeywell Applications

Honeywell applications help you troubleshoot and connect your computer to other devices and networks. Some of the applications in this table are located in the Power Tools app. To learn more about Honeywell Power Tools, go to sps.honeywell.com to download the *Dolphin Power Tools User Guide*.

Honeywell Applications Available on the Computer

Icon	Application	Description
	AutoInstall Settings	Enable the AutoInstall feature, to automatically install *.zip or *.apk files containing applications saved in the Internal shared storage\honeywell\autoinstall folder and IPSM card\honeywell\autotinstall folder on the computer during the power-up boot or reboot process.
	Demos	Honeywell Demo apps demonstrate the basic capabilities of the computer and are not intended as functional business solutions. The demos included, demonstrate scanning, signature capture, NFC functionality, and printing via Bluetooth technology. Information on how to create custom applications for your Honeywell computer can be found in the Honeywell Software Development Kit (SDK) for Android, available from the Technical Support Downloads Portal .
	HUpgrader	Use the HUpgrader app to view the current OTA version on the computer, check for updates, or initiate an OTA upgrade from storage.
	Scanner Edge	Use the Scanner Edge app to connect or disconnect a Bluetooth scanner. <ul style="list-style-type: none"> View connected devices. Pair with a Bluetooth Scanner. Disconnect a Bluetooth Scanner.
Power Tools		
	BattMon	BattMon provides information on the charge status and health of the battery, and provides access to activate battery status notifications and battery charging history logs.
	Config Apps	Config Apps provides the ability to enable, disable, and uninstall applications.
	Configure Autorun	Configure Autorun provides the ability to set applications to automatically run after a reboot.
	Diagnostic Information	Diagnostic Information provides access to system statistics, notifications and version information about the computer.

Icon	Application	Description
	EZConfig	EZConfig supports advanced customization and configuration of the hand held computer. EZConfig includes a standard XML editor and configuration barcode scanner feature.
	WiFi Diagnostic	Use application to: <ul style="list-style-type: none"> • View Wi-Fi radio status information about a connected access point or a list of other available access points in range of the Wi-Fi radio. • Use the Route utility to view packet destination gateway information across the subnets. • Use the IPConfig utility to view IP parameters for the on-board network adapters. • Use the Ping utility to verify communication links or to make sure a specific IP address is working.
	Wireless Tether	Use to enable range tracking and customize out-of-range alerts for Bluetooth devices paired and tethered to your hand held computer.

Applications You Can Download to the Computer

You can download Honeywell applications to extend the capabilities of the computer. You may need to purchase a license to run some applications. To learn more about the applications described in this section and other Honeywell software solutions, go to sps.honeywell.com and select **Software > Productivity**.

About Honeywell Enterprise Browser

Enterprise Browser is a locked-down enterprise Web client application designed for Honeywell computers. It provides a controlled Web application environment that helps enterprises increase productivity and reduce IT management expenses. You can configure Enterprise Browser for your specific application requirements and design custom web applications that run through the Enterprise Browser to provide your users with an easy-to-use yet controlled experience.

If Enterprise Browser is not included on your computer model, you can download a trial version for evaluation. After the evaluation period expires, you need to purchase a license. For more information about Enterprise Browser, visit sps.honeywell.com.

About Honeywell Launcher

Launcher is a configurable locked-down menu program designed for Honeywell computers that prevents end-users from accessing the start menu and other non-authorized applications. Use Launcher to provide a platform where your computer users are limited to running only company-approved applications and prevent

them from initiating unauthorized configuration changes. You can also use Honeywell Launcher together with Honeywell Enterprise Browser to create a single-purpose device configuration.

If Launcher is not included on your computer model, you can download a trial version of the software for evaluation. After the evaluation period expires, you need to purchase a license. For more information about Launcher, visit sps.honeywell.com.

About UEMConnect

Honeywell UEMConnect enables customers to use the Google OEMConfig protocol to perform enterprise configuration and enhance the management of Honeywell Mobility Edge™ devices. It seamlessly integrates with EMM solutions to expose Honeywell management extensions directly on the EMM console. UEMConnect provides exclusive access to over 260 advanced Honeywell proprietary settings and provides supplemental access to standard EMM features. EMM providers may also make use of generic Android APIs to provide standard EMM functionality.

Honeywell UEMConnect is available for download in the Google Play™ store. UEMConnect licenses are included with the purchase of applicable SOTI offerings through Honeywell or may be purchased separately for applicable EMM solutions not purchased through Honeywell.



Honeywell SmartTE

Honeywell SmartTE is a wireless terminal emulation and centralized management software program. SmartTE is designed to centralize wireless session/client configurations, secure end-to-end wireless data transmission, program screen recognition, track unique devices and usage, and provide visible analytical and application data.

For more information, please contact [Technical Assistance](#) on page ix.

Unlock Developer Options

Developer options only appear in the Settings app if you unlock the feature. If you are a developer working with the computer, you can easily unlock the additional settings to use for testing and debugging applications under development for the computer.

1. Swipe up from the bottom of the Home screen to access all apps.
2. Tap **Settings**  > **About phone**.
3. Tap **Build number** seven times. A message appears informing you that you are now a developer.
4. Open **Settings**  and scroll to the bottom of the list.

5. Tap **Developer options**.

CONFIGURE THE COMPUTER

Use this chapter to learn about the available methods for configuring your computer. You can also use this chapter to learn how to configure network communication and wireless security.

How to Configure the Computer

You can configure many parameters on the computer such as the bar code symbologies it decodes or the network settings. The values you set for these parameters determine how the computer operates.

You configure the computer using the Settings app.

Start the Settings App

The Settings app is available from the all apps menu and the notification panel.

- Swipe up from the bottom of the Home screen to access all apps, and then tap **Settings** .

OR



- Swipe down from the top of the Home screen, and then select  in the status bar.

About the Structure of the Settings App

Use this section to learn about the structure of the Settings app so you can find parameters quickly.

Note: *The Settings app varies by computer model and OS version. Your computer may not include all the features outlined in this section.*

When you open the Settings app, suggestions may appear at the top of the list.

- Tap  or  to expand or collapse the suggestion list.

- Tap a suggestion to open the settings screen or app relevant to the suggestion.
- Tap  and then tap **Remove** to dismiss the suggestion.

Network & internet

Setting	Description
Wi-Fi	<ul style="list-style-type: none"> • Turn Wi-Fi on or off. • Lists available Wi-Fi networks in range and the connection status when the radio is turned on. • Add a network Wi-Fi connection. • Tap Wi-Fi preferences to view saved networks, turn public network notifications on or off, modify WLAN radio sleep settings, and view MAC and IP address information.
Airplane mode	Turn Airplane mode on or off.
Ethernet	<ul style="list-style-type: none"> • Turn Ethernet connection on and off. • Configure Ethernet connections and set up proxy settings when Ethernet setting is turned on.
Data Saver	Turn the Data saver feature On or Off. Specify which apps can use unrestricted data.
VPN	Set the password parameters for a virtual private network (VPN) connection.
Private DNS	Select Private DNS mode.

Connected devices

Setting	Description
USB	Select the type of communication: <ul style="list-style-type: none"> • File Transfer • USB Tethering • MIDI • PTP • No data transfer <p>Note: This setting only appears when the unit is connected via USB.</p>
Pair new device	<ul style="list-style-type: none"> • Connect to a Bluetooth Device. • Lists Bluetooth enabled devices in range. • View and rename the computer. • View the computer Bluetooth address.
Connection preferences	
Bluetooth	<ul style="list-style-type: none"> • Use Bluetooth - Turn the Bluetooth radio on or off. • Lists Bluetooth enabled devices in range when the radio is turned on. • Connect to a Bluetooth Device.

Setting	Description
NFC	<ul style="list-style-type: none"> Use NFC - Turn Near Field Communication (NFC) on or off. When the NFC radio is enabled, data exchanges are allowed when the computer touches another NFC enabled device. Contactless Payments - View and select defaults for contactless payments
Cast	<ul style="list-style-type: none"> Enable wireless display. Connect to nearby devices.
Printing	Configure print options.
Chromebook	Set up a connection from the VM1A to a Chromebook.
Nearby Share	Share files with nearby devices.

Apps

Setting	Description
Apps info	View a list of all apps installed on the computer or system services running.
Default apps	View and manage default app use.
Screen time	<ul style="list-style-type: none"> Shows Screen time, Notifications received, Times opened. Allows to set app timer.
Unused apps	View and manage apps that are unused for over three months.
Special app access	Manage apps with special unrestricted access.

Notifications

Setting	Description
Apps settings	View a list of all apps installed on the computer or system services running.
Notification history	Shows recent and snoozed notifications.
Conversations	Priority and modified conversations will appear here.
Bubbles	Turn on Bubbles to enable conversations to appear as floating icons on top of other apps.
Device & app notifications	Set rules for notifications.
Notifications on lock screen	Controls display of notifications on lock screen
Do Not Disturb	Set people, apps, and alarms that notifications will be displayed from
Hide silent notifications in status bar	Icons from apps with silent notifications will not be displayed in the status bar.
Allow notification snoozing	Silences notifications for up to two hours.
Notification dot on app icon	Displays a dot on the icon for an app with an active notification.
Blink light	Enables a blinking light to display when a notification is received.

Setting	Description
Enhanced notifications	Shows suggested actions and replies and organizes notifications.

Battery

Setting	Description
Battery	View current battery charge or charging status.
Battery usage	Displays battery usage from last full charge.
Battery Saver	<p>Turn the Battery saver feature On or Off manually.</p> <p>Set a schedule, based on the battery charge percentage (%) remaining that automatically activates the Battery saver feature. Use the slider to set the battery percentage level. Slider adjusts from 5% to 7% and is only available once schedule is selected.</p> <p>When charging, set the battery saver feature to turn Off during when the battery reaches 90%. Default setting.</p>
Battery Manager	Turn the Battery Manager On or Off. Battery manager detects when apps drain the battery.
Battery Percentage	Enable battery percentage in status bar.

Display

In the Settings app, select **Display** to access the following settings.

Setting	Description
Brightness level	Set the Brightness level manually if Adaptive brightness feature is turned Off.
Dark theme	Enable dark mode to switch app backgrounds to a black color.
Night light	Activate the Night light feature to adjust the screen tint to a light amber for easier viewing and reading in dim light or for the hours you use the device before going to sleep. Set the feature to stay on or define a schedule to automatically turn the feature On/Off. You can manually adjust the intensity of the amber hue once the feature is activated.
Adaptive brightness	Set how the screen in sleep mode responds when new notifications are received (e.g., wake or do not wake).
Screen timeout	Set the inactivity time limit before the unit automatically turns of the screen to save battery power (seconds or minutes).
Colors	Select to display Natural or Boosted colors.
Keypad backlight	Set the inactivity time limit before the keypad backlight automatically turns off (seconds or minutes).
Auto-rotate screen	Set the screen to switch from portrait to landscape when the unit is rotated. When Off the screen does not automatically rotate.
Font size	Set the default on-screen text size.
Display size	Set the default size of items on your screen.
Screen saver	Set the screen saver.
Lock screen	Select what to show on the lock screen and when to display new notifications.

Wallpaper

Select the wallpaper from Live Wallpapers, Photos, or Wallpapers on the unit.

Sound

In the Settings app, select **Sound** to modify the audio and sound settings. To learn more, see [Audio Settings](#) on page 24.

Storage

In the Settings app, select Storage to view statistics on available and used storage space on the device and on any portable storage cards installed.

Privacy

In the Settings app, select **Privacy** to define privacy settings for the device.

Setting	Description
Privacy dashboard	Shows which apps recently used permissions.
Permission manager	Define which apps have access to features on the device, such as the camera or microphone.
Microphone access	Allows microphone access for apps and services.
Show passwords	Briefly displays the characters in a password as you type before hiding them.
Notifications on lock screen	Select whether or not to show all notification content on the lock screen.
Show clipboard access	Displays a message when apps access text, images, or other content you've opened.
Autofill service from Google	Automatically fill fields using saved data from your Google account.
Google location history	Enable or disable location history and manage or delete activity. A Google account must be associated with the device to use this feature.
Activity controls	Choose what type of activities are saved in your Google account. A Google account must be associated with the device to use this feature.
Ads	Opt in or out of ad personalization features. When this is on, ads are personalized with the activity and information from your Google Account.
Usage & diagnostics	Automatically send diagnostic, device, and app usage data to Google. By default, this setting is turned off.

Location

In the Settings app, select **Location** to define which apps have access to the device's location.

Setting	Description
Use Location	Turn location services (Google and GPS satellite data) On or Off. Set location mode accuracy and view location request history.
App access to location	View and manage app-level location service permissions.
Wi-Fi and Bluetooth Scanning	Turn Wi-Fi and/or Bluetooth scanning On or Off. When enabled system apps and services are allowed to detect Wi-Fi networks or Bluetooth devices at any time to improve location services.
Emergency Location Service	Allows the device to automatically send its location to emergency locations.
Google Location Accuracy	Improves location accuracy by using Wi-Fi, mobile networks, and sensors to help estimate the device location.
Google Location History	Allows the device to report Location History to Google. A Google account must be associated with the device to use this feature.
Google Location Sharing	Allows the device to share its location with anyone in the contacts list.

Safety & Emergency

In the Settings app, select **Safety & Emergency** to define emergency contact information.

Setting	Description
Emergency Information	View or update medical information and emergency contacts.
Emergency SOS	Define Emergency SOS settings.
Emergency Location Service	Turn Emergency Location Service on or off.

Security

In the Settings app, select **Security** to view latest Security scan results, security updates and phone encryption status. Access additional settings related to device security.

Setting	Description
Google Play Protect	Manually initiate a scan of the apps on the device to check for problems.
Find My Device	Allows users to locate, ring, or wipe a device remotely.
Security update	Displays the last date security was updated on the device.
Screen Lock	Activate and configure a screen lock (i.e., None, Swipe, Pattern, Pin, Password).
Smart Lock	Define safe conditions or locations where your phone will stay unlocked (e.g. On-body, Trusted places, Trusted devices, Voice Match).
Device admin apps	Manage administrator privileges.
Encryption & credentials	View encryption status and manage trusted credentials (e.g., view, install, clear, and edit).
Trust agents	View and enable/disable trusted agent apps such as, Smart Lock by Google on the device. Trusted agents bypass security based on set parameters.
App pinning	Enable or disable the screen pinning feature. When enabled you can pin the device screen to a recently used app where it stays until you unpin the app via the security method chosen.

Passwords & Accounts

In the Settings app, select **Passwords & Accounts** to access the following settings.

Setting	Description
Passwords	View, change, or remove passwords saved in your Google account.
Autofill service	Turn Autofill with Google on or off.
Add account	Select to add and manage Corporate or Email account on the computer.
Automatically sync app data	Turn auto-sync On or Off for accounts. Turning the feature On allows apps to refresh data automatically.

Accessibility

In the Settings app, select **Accessibility** to access screen readers, display settings, interaction controls, and audio & on-screen text features to improve accessibility levels.

Setting	Description
ScanWedge Accessibility	Turn ScanWedge Accessibility on or off.
Touch Gesture	Select to use Touch Gesture service to allow multi-touch gestures.
Display	

Setting	Description
Text and Display	Configure display features that may aid visual accessibility levels. <ul style="list-style-type: none"> • Adjust Font size • Adjust Display size • Turn Bold text On/Off • Set Color correction • Turn Color inversion On/Off • Turn Remove animations On/Off • Turn Large mouse pointer On/Off • Turn High contrast text On/Off
Extra Dim	Turn on to dim screen beyond device's minimum brightness
Dark Theme	Turn Dark Theme On/Off
Magnification	Turn Magnification On/Off
Timing controls	Configure timing controls: <ul style="list-style-type: none"> • Touch & hold delay • Time to take action (Accessibility timeout) • Autoclick (dwell timing)
System controls	Configure system controls: <ul style="list-style-type: none"> • System navigation • Power button ends call • Auto-rotate screen
Caption preferences	Turn captions on or off, set caption size and style
Audio adjustment	Turn Mono audio On/Off, set Audio balance.
Accessibility shortcuts	<ul style="list-style-type: none"> • Accessibility button - Toggle on to allow feature shortcut to turn on from the lock screen by holding down both volume buttons. • Shortcut from lock screen - Allow feature shortcut to turn on from the lock screen.
Text-to-speech output	Select and configure the preferred TTS, set language, speech rate and pitch of synthesized voice.

Honeywell Settings

Setting	Description
Honeywell Power Setting	Turn unattended mode On/Off.
HXLogger	<p>The HXLogger is an advanced diagnostic log service that provides a basic log service, plug-ins for modified log services, and a log manager.</p> <ul style="list-style-type: none"> • Tap HXLogger to turn the basic log service on or off. When enabled the service records app and system diagnostic troubleshooting information into four basic log files: main log file, radio log, event log, and kernel log. • Tap Plugin to view and enable additional log services and custom plug-ins. • Tap Manager, to change the default log path, delete logs or upload logs for technical support troubleshooting.
Keyremap	Change (remap) a button or key function. To learn more, see Remap a Button or Key on page 33.
Link LED Indicator	Set Link LED Indicator settings: IP address, ping rate, failed ping count threshold, degraded link threshold, and failed link threshold.
I/O Ports	<ul style="list-style-type: none"> • Turn USB Powered in Sleep On/Off. • Turn 5V on COM1 On/Off. • Turn 5V on COM2 On/Off. • Set COM1 settings. • Set COM2 settings.
Misc	<p>Turn on or off miscellaneous features.</p> <ul style="list-style-type: none"> • Permanent Caps Lock Enable • Touch Screen Disable • Enable Keypad Backlight
Power Mode	<ul style="list-style-type: none"> • Set Power Mode to AC/DC, Auto-On, Ignition Control, or UPS. • Set Power Schedule for Switch state to Sleep and Switch state to Shutdown.
Provisioning Mode	Enable or disable unrestricted installation of applications, certificates, configuration files, and licenses. Provisioning mode is turned off by default. To learn more About Provisioning Mode , see page 70.
Scanning	Enable or disable serial scanner COM1 and COM2. Configure serial scanner COM1 and COM2.
Staging Hub Agent	Use this agent and settings to connect the computer to the Honeywell Staging Hub Foundation software platform; a centralized software platform IT integrators and administrators can use as a solution for managing, monitoring and deploying Honeywell devices in a connected workspace environment.
Sticky Option	Choose whether functions keys are “sticky” (remain active after being pressed). The default is Off.
Voice Wedge	Voice-to-text conversion tool that can be triggered by a specified start word or key press event. Voice Wedge can be configured to take effect globally or only for an associated application.
Web Applications	Enables access for the Honeywell Mobility SDK for Web apps and lets you set a port.

Setting	Description
Wi-Fi Staging	Use the Honeywell Wi-Fi Staging app to quickly set up new devices by configuring one device and using it to stage others. Wi-Fi Staging can also be used to enroll devices in an Mobile Device Management (MDM) system by connecting units to a specified network and downloading and installing the specified MDM client app. To learn more, see page 63.
Zoomzone	Configure screen blanking and define the zoom area that is displayed when motion is detected. To learn more, see page 18.

Digital Wellbeing & parental controls

In the Settings app, select **Digital Wellbeing & parental controls** to access options that monitor screen time and other features. See <https://wellbeing.google/>.

Google

In the Settings app, select **Google** to set up and manage your Google accounts and services.

System

Setting	Description
Languages & input	<ul style="list-style-type: none"> Set the active language. Configure auto-typing features such as capitalization, punctuation, spell check, and the personal dictionary. Set and manage Keyboard and input methods (Virtual and Physical). Set text-to-speech output. Adjusts the pointer speed.
Gestures	<ul style="list-style-type: none"> Turn Jump to Camera On/Off. Select navigation options (Gesture, 2-button, 3-button). Set the Prevent ringing option. Options: Vibrate, Mute, Do Nothing.
Date & time	Configure all date and time settings
Scheduled power on and off	Schedule times for the power to turn on and off on the device.
Backup	Perform a Factory Reset. To learn more, see About a Factory Data Reset on page 76.
Reset options	<p>Select from the following reset options:</p> <ul style="list-style-type: none"> Reset Wi-Fi, Mobile & Bluetooth Use to reset all network settings, including Wi-Fi, Mobile data and Bluetooth. Reset app preferences. Use reset app preference back to defaults. This apps you disabled, notification changes, default app actions set, background data restrictions for apps and permission restrictions. Enterprise data reset. To learn more, see About an Enterprise Data Reset on page 138. Erase all data (factory reset). To learn more, see About a Factory Data Reset on page 139.

Setting	Description
Multiple Users	<ul style="list-style-type: none"> • Modify the owner profile name and add profiles for other people who use the computer. • Activate a different user profile. • Enable or disable allowing users to be added from the lock screen.

About Phone

In the Settings app, select **About Phone** to access the following settings.

Setting	Description
Device name	A nickname to identify the device. To change, tap Device name and enter a new name.
Phone number	The phone number assigned to the device.
Legal information	Provides links to third-party licenses and other legal information.
Compliance information	Displays certification and compliance information.
Model	Displays the model number, serial number, and hardware version of the device.
Android version	The version of Android on the device. Tap to view additional details.
Asset number	Asset tag assigned to the device.
IP address	IP address associated with the device.
Wi-Fi MAC address	The MAC address for the Wi-Fi network
Device Wi-Fi MAC address	Enabled when there is a Wi-Fi network connected to the device
Bluetooth Address	Bluetooth address information
Second BLE MAC address	If there is more than one BLE MAC address, that information is listed here
Up Time	How long the device has been in use during the current session
Software component version	<p>Here you can find the following information:</p> <ul style="list-style-type: none"> • Honeywell Android Extension • Enabling Solution • Mobile Device Management • Touch Panel Version • AMSS • OS Extension SDK version • Second BLE version
Build number	The current OS version build number on the device



About Network Communications

You can easily add the computer to your wireless or wired data collection network. Connect the VM1A to your computer using:

- 802.11 a/b/g/n/ac radio communications.
- Ethernet communications.
- Bluetooth communications.
- USB and serial communications.

Connect to a Wi-Fi Network

The computer contains an 802.11 a/b/g/n/ac radio to transfer data using wireless communications. Before you connect to a Wi-Fi network, you need to know about your network security protocol and its required credentials.

1. Swipe up from the bottom of the Home screen to access all apps.
2. Tap **Settings**  > **Network & internet** > **Wi-Fi**.
3. Tap **Off**  to toggle the Wi-Fi radio **On** . A list of discovered networks appears.
4. On the list, tap a network name to initiate a connection.

To add a network if it does not appear on the list:

- a. Navigate to the end of the discovered network list, and then tap **Add network**.
 - b. Type the Wi-Fi network name (SSID).
 - c. Choose a security protocol and add any required information.
 - d. Tap **Save**.
5. Enter any required information if the network is secured (e.g., password, key or certificate name).
 6. Tap **Connect**.

Once you connect to a saved Wi-Fi network:

- Tap the network name on the list to view details (e.g., status, signal strength, speed, frequency, security type). Select **Cancel** to close details screen.
- The computer automatically connects to the same network when the network is in range and the WLAN radio is turned on.
- To remove a network from your saved list, tap and hold the network name and select **Forget**. You can do this for networks you no longer use.
- To modify a network from your saved list, tap and hold the network name and select **Modify**. You can do this if you changed your network password.
- To view a list of only your saved networks, tap **Saved networks**.

Configure Proxy Settings for a Wi-Fi Network

If you need to connect to network resources through a proxy server, you can configure settings for the proxy server for each Wi-Fi network you add. By default, the Wi-Fi networks you add are not configured to connect through a proxy server.

Note: Proxy settings apply only to the Wi-Fi network you modify. You must change proxy settings for each network requiring a proxy server.

1. Swipe up from the bottom of the Home screen to access all apps.
2. Tap **Settings**  > **Network & internet** > **Wi-Fi**. The list of available Wi-Fi networks appears.
3. Tap and hold the name of a connected network, and then tap **Modify**.
4. Tap **Advanced options**.
5. Under **Proxy**, tap **None** to open menu, and then select **Manual**.
6. Enter the proxy settings for the network.
7. Tap **Save**.

Disable Wi-Fi Notifications and Set WLAN Radio Sleep Parameter

By default, when Wi-Fi is enabled, you receive notifications in the Status bar when the computer discovers a wireless network. You can disable these notifications.

1. Swipe up from the bottom of the Home screen to access all apps.
2. Tap **Settings**  > **Network & internet**. Verify the WLAN radio is turned on.
3. Tap **Wi-Fi**.
4. Tap **Wi-Fi Preferences**.
5. Tap **Notify for public networks** to toggle the setting on or off.

Connect to an Ethernet Network

To connect the computer to an Ethernet network.

1. Swipe up from the bottom of the Home screen to access all apps.
2. Tap **Settings**  > **Network & internet** > **Ethernet**. The Ethernet setting is turned **On** by default.
3. Tap **Ethernet**.

The Ethernet connection screen shows the current Ethernet connection. By default, the computer assumes a DHCP connection, and that your network has assigned an IP address automatically.

4. (Optional) To assign a static IP address.

- a. Tap **DHCP** and then select **Static** from the list.
 - b. Enter the required network information, and then tap **Apply**.
5. Tap **Save**.

How to Connect to Virtual Private Networks

The computer supports connecting to virtual private networks (VPNs). This section describes how to add and connect to VPNs. To configure VPN access, you must obtain details from your network administrator. You view and change VPN settings in the Settings app.

Note: Before you can add or connect to a VPN network, you must enable a screen lock method.

Add a VPN

Before you can connect to a VPN, you must create a VPN profile.

1. Swipe up from the bottom of the Home screen to access all apps.
2. Tap **Settings**  > **Network & internet** > **VPN**.
3. Tap **+** to add a VPN new profile.
4. Enter the required information for the VPN connection. If needed, swipe up on the screen to access all the required information fields.
5. Tap **Save**. The VPN name appears in the VPN list.

Connect to a VPN



Once a VPN profile is created, you can connect to the VPN at any time.

1. Swipe up from the bottom of the Home screen to access all apps.
2. Tap **Settings**  > **Network & internet** > **VPN**.
3. Tap the name of the VPN in the list.
4. Enter any necessary credentials when prompted.
5. Tap **Connect**.

A  appears in the status bar and a notification is received. To disconnect from the VPN, tap the notification.

Edit VPN Information

Editing an existing VPN profile be done from the VPN screen.

1. Swipe up from the bottom of the Home screen to access all apps.
2. Tap **Settings**  > **Network & internet** > **VPN**.
3. Tap and hold the name of the VPN in the list.
4. Tap  to the right of the VPN profile you want to edit.
5. Edit the VPN settings as necessary.
6. When you are done, tap **Save**.

About Wireless Security

The computer provides these security solutions for your wireless network:

- Wi-Fi Protected Access 2 (WPA2™)
- Wi-Fi Protected Access (WPA)
- 802.1x

Honeywell recommends WPA2 security with PSK (Personal) or 802.1x (Enterprise) key management.

Before you set security, you need to enable the radio, set the date, and set the SSID on your computer. To use 802.1x security, you need to load a root certificate on your computer. To use transport layer security (TLS) with 802.1x security, you also need to load a user certificate.

Use the Settings app to access and configure all wireless security settings.

About Certificates

You can use digital certificates to identify the computer for network access or authentication to servers. To use a certificate to identify your device, you must install it in the trusted credential storage on the computer.



Android supports DER-encoded X.509 certificates saved in files with a .crt or .cer file extension. To install a valid certificate with a .der or other extension, you must change the extension to .crt or .cer to install it.

Android also supports X.509 certificates saved in PKCS#12 key store files with a .p12 or .pfx extension. To install a valid key store file with another extension, you must change the extension to .p12 or .pfx to install it. When you install a certificate from a PKCS#12 key store, Android also installs any accompanying private key or certificate authority certificates.

Load a Certificate

To use a certificate, you must install it in the trusted credential storage on the computer.

Note: Apps such as email and browsers that support certificates allow you to install certificates directly from within the app. For more information, see the help that comes with the app.

1. Copy the certificate or key store from your PC to the computer.
2. Swipe up from the bottom of the Home screen to access all apps.
3. Tap **Settings**  > **Security** > **Encryption & credentials**.
4. Tap **Install a certificate**.
5. Select either **CA certificate**, **VPN & app user certificate**, or **Wi-Fi certificate**.
6. Tap the Menu icon , and then navigate to the location where you saved the certificate.
7. Tap the certificate or key store to install it. If prompted, enter the key store password and tap **OK**.
8. Enter a name for the certificate and tap **OK**.

Disable or Remove Certificates

If a user or system certificate is compromised, or your organization chooses not to trust it, you can disable or remove the certificate.

1. Swipe up from the bottom of the Home screen to access all apps.
2. Tap **Settings**  > **Security** > **Encryption & credentials** > **Trusted credentials**.
The trusted credentials screen has two tabs:
 - **System** shows Certificate Authorities (CA) certificates permanently installed on the computer. They can only be disabled.
 - **User** shows CA certificates you have installed yourself. You can remove these certificates.
3. Tap the name of the certificate to you want to disable or remove. The Security certificate screen appears.
4. Scroll to the bottom of the screen and tap **Disable** (for System certificates) or **Remove** (for User certificates).
5. Tap **OK**.

Note: You can enable a disabled System certificate but if you remove a User certificate, you must install it again to enable it.

About Bluetooth Communications

Your computer is equipped to communicate with other devices using Bluetooth technology. The Bluetooth radio must be turned on to discover, pair and connect to other Bluetooth devices. System bar icons indicate Bluetooth radio status.

Connect a Bluetooth Device

To connect to a Bluetooth device, you must turn on the Bluetooth radio and then select the device from a list of discovered devices.

1. Swipe up from the bottom of the Home screen to access all apps.
2. Tap **Settings**  > **Connected devices**.
3. Tap **+ Pair new device**. A list of Bluetooth devices appears.
4. Select a device on the list to initiate a pairing request.
5. When the pairing request message appears:
 - Determine whether the device should access contacts and call history.
 - If the pairing PIN is the same on both devices, verify the PIN and then tap **Pair**.
 - If the pairing request requires a PIN, enter the **PIN** and then tap **Pair**.
6. When the device is successfully paired with the computer, the device name appears under **Previously Connected Devices**.
7. (Optional) To connect manually to the device, tap the device name under **Previously Connected Devices**. The connected device name appears under **Other Devices**.

The status icon changes from  to .

Note: To disconnect a paired device, tap  next to the name of the paired device and then tap **Forget**.



Rename the Computer and View File History

You can change the name of the computer to make it easier to identify when pairing with other Bluetooth enabled devices and view statistics about received files.

1. Swipe up from the bottom of the Home screen to access all apps.
2. Tap **Settings**  > **Connected devices** > **Connection Preferences** > **Bluetooth**.
3. Tap **Device name**. Type new name and then tap **Rename**.

Rename or Unpair a Paired Device



You can rename a paired device to make it easier to identify on the list or unpair the device to remove it from the paired list.

1. Swipe up from the bottom of the Home screen to access all apps.
2. Tap **Settings**  > **Connected devices**.
3. Tap  next to the paired device.
4. Take one of the following actions:
 - To rename the device, tap  to open the Device name screen. Type the new name, and then tap **Rename**.
 - To allow **Internet access** or **Contact Sharing**, tap the setting.
 - To unpair the device, tap **Forget**.

About the Scanner Edge App



Your mobile computer is equipped to communicate with scanners using Bluetooth technology through the Scanner Edge app. The Bluetooth radio must be turned on. System bar icons indicate Bluetooth radio status.

To turn on the Bluetooth radio:

1. Swipe up from the bottom of the Home screen to access all apps.
2. Tap **Settings**  > **Connected devices** > **Bluetooth**.
3. If necessary, tap **Off**  to toggle the Bluetooth radio **On** .

Connect a Bluetooth Scanner



To connect to a Bluetooth scanner, the Bluetooth radio must be turned on and then scan a pairing barcode with the Bluetooth scanner.

1. Swipe up from the bottom of the Home screen to access all apps.
2. Tap **Scanner Edge** .
3. Tap the menu icon  and then tap **Pair BT Scanner**.
4. For Honeywell branded scanners tap **Honeywell** or for Intermec branded scanners tap **Intermec**.
5. Scan the **Scan to connect barcode** displayed on screen.

6. When the scanner is successfully paired with the computer, the scanner name appears under Connected Device.

Unpair a Paired Scanner

You can unpair the scanner to remove it from the Connected Device list.

1. Swipe up from the bottom of the Home screen to access all apps.
2. Tap **Scanner Edge** .
3. Tap the menu icon  and then tap **Disconnect BT Scanner**.
4. Tap **Honeywell** or **Intermec**.
5. Scan the **Scan to disconnect barcode** displayed on screen.

USB Troubleshooting

- If you have a problem with your workstation computer recognizing the USB device, try downloading and installing the Honeywell-aidc-usb-driver. The driver is part of the Honeywell_Mobility SDK_Android software.zip file. To learn where to get the software, see [Developer and Device Management Information](#) on page 62.
- Check to make sure you have enabled the USB for file transfer. To learn more, see [Connected devices](#) on page 44.

About Near Field Communication (NFC)

NFC technology provides the ability for short-range, wireless data transfer between the VM1A and NFC tags or other NFC enabled devices placed in close proximity to the back of the computer. All VM1A computers support the following modes of operation:

- NFC tag reader/writer mode: The computer reads and/or writes digital information from or to an NFC tag.
- Peer-to-Peer (P2P) mode: The computer uses Android Beam and/or Bluetooth technology to transfer screen content (e.g., a picture, contact information, Web page URL, or file) between NFC enabled devices.
- NFC card emulation mode: The computer emulates an NFC card (smart card) that an external card reader can access. You can download and install apps for card emulation mode from the Google Play™ store. Some examples include digital wallets (e-wallets) offered by your bank or credit card company and Google Pay™. The app you install determines the type of emulation mode used: Card Emulation with a Secure Element or Host-based Card Emulation. Secure element use is common for financial transactions that require a high

level of security in order to provide a secure memory and execution environment for running custom smart card applets and storing your personal information (e.g., account information and credentials).

Note: *When using a Universal Integrated Circuit (UICC) card for NFC Secure Element NFC link encryption, install the card in SIM slot 1.*

Developer and Device Management Information

To download the Honeywell Mobility SDK for Android, Enterprise Provisioner, and Staging Hub:

1. Go to the *Technical Support Downloads Portal* link, honeywell.com/PSSsoftware-downloads.
2. Create an account if you have not already created one. You must login to download the software.
3. Install the *Honeywell Download Manager* tool on your workstation (e.g., laptop or desktop computer) prior to trying to download any files.
4. Navigate to the software:
 - *Honeywell Mobility SDK for Android*
Click on **Software > Software and Tools > Developer Library > SDKs for Android**.
 - *Enterprise Provisioner and Staging Hub*
Click on **Software > Software and Tools > Device Management > Staging Hub Foundation > Current**.
5. Select **Download** next to the software zip file.

For more information about Honeywell Mobility SDK for Android, Enterprise Provisioner, and Staging Hub, visit sps.honeywell.com.

About Provisioning Mode

Once you complete the out-of-box initial setup process, Provisioning mode is automatically turned off to improve device security against unwanted modifications to the system.

When Provisioning mode is turned off (disabled):

- Configuration barcodes do not scan and process.
- \honeywell\autoinstall folders are inaccessible.

Note: *To learn more about network and security for Honeywell computers with Android operating systems, go to sps.honeywell.com.*

Enable or Disable Provisioning Mode

1. Swipe up from the bottom of the Home screen to access all apps.
2. Tap **Settings**  > **Honeywell Settings** > **Provisioning mode**.
3. Tap the button to toggle the provisioning On or Off.

About Wi-Fi Staging

You can use the Honeywell Wi-Fi Staging app to quickly set up new devices by configuring one device and using it to stage others. Wi-Fi Staging can also be used to enroll devices in a Mobile Device Management (MDM) system by connecting units to a defined network and downloading and installing the MDM client app.

Once you have set up a configuration in the Wi-Fi Staging app on the server device, Wi-Fi staging uses that device as a hotspot and waits for a client to connect. The configuration is distributed to the client device once communication is established between the client and the server device.

Staging Devices

Wi-Fi Staging requires two steps:

1. Set up a master device to act as a server (see next section).
2. Set up the client device (see [Set Up Client Devices](#) on page 66).

Set Up a Device as a Server

Wi-Fi Staging provides two kinds of configurations for a master device acting as a server through a hotspot. Setup of the server device differs based on the staging configuration chosen:

- **Basic Configs** include the most common system settings:
 - System language
 - Bluetooth and NFC
 - System volume
 - Location
 - Network
 - File download
 - Application installation or launch

- **Advanced Configs** allow you to stage your devices with .xml files

The hotspot on the server device will be named HONEYWELL_WIFI_STAGING.

Note: We recommend setting up the server before setting up clients. If the server is not created in advance, client setup requires more time and power to scan and search for the hotspot signal.

Note: To control bandwidth usage, the server side of Wi-Fi Staging has a maximum limitation of 10 concurrent client connections. If more than 10 client devices attempt to connect to the server device at the same time, staging of some of those clients will be delayed until client connections become available as the staging process progresses.

Basic Configuration

Basic configuration includes the most common system settings.

1. Tap **Settings** > **Honeywell Settings** > **Wi-Fi Staging** to launch the Wi-Fi Staging app on the server device.
2. Tap **Basic Configs** to start the configuration wizard.
3. Select system language. Tap **+** to add a language. At least one language must be selected. Tap **NEXT**.
4. Select connection preferences. Enable Bluetooth and/or NFC. They are disabled by default. Tap **NEXT**.
5. Select sound preferences. Adjust the default volume for each type of audio by dragging the slider, and then tap **NEXT**.
6. Enable the location switch. It is disabled by default. Tap **NEXT**.
7. Set up **Network & Internet** connection or tap **SKIP** to proceed to Step 9 if you do not want to set up a network connection.

You would need to set up a Network & Internet connection if you want to register devices to an MDM system or the devices being registered need to use applications that require network access.

If you want to set up devices to connect to a Wi-Fi access point, enter the network information:

- a. Tap **Wi-Fi Security** and select either **OPEN** or **WPA/WPA2**.
 - b. Enter the Wi-Fi SSID, and then tap **OK**. This field cannot be left empty.
 - c. Enter the Wi-Fi password. The password must be between 8 and 63 characters long. If you select WPA/WPA2, a password is required.
 - d. Tap **NEXT**.
8. The **Files & Apks** option only appears if you chose to set up Network & Internet connections in step 7.

Enter the locations (URLs) of the **Files & Apks** that you want downloaded.

- The URL should end with the file that you want to download. Wi-Fi Staging names the downloaded file with the file name in the URL.
 - (Optional) You can include a file's hash in the file name. Wi-Fi Staging supports hash algorithms SH1 and SHA256.
 - For security, Only Local Area Network URLs are supported for security. Wi-Fi Staging ignores URLs from Wide Area Networks.
 - Supported network protocols include HTTP or HTTPS.
 - APK files are installed silently and automatically after download.
9. **Final Setting:** Select whether you want to reboot the device after staging is complete. You can also specify an action (intent) to launch Android activities.
 10. Review the items you have configured. If you need to change a setting, tap the Back button to return to the relevant screen.

Tap **Confirmed, start staging now!** to begin. Wi-Fi Staging starts a hotspot on the server device and wait for clients to connect.

11. Proceed to [Set Up Client Devices](#) on page 66.

Configurations are distributed to any client that connects to the server device. Once the data transmission finishes successfully, the name and serial number of the configured client is displayed in the Wi-Fi Staging app on the server device and the client device skips the Android setup wizard.

Note: *If you included a file's hash in Step 8, Wi-Fi Staging will validate that the hash of the file downloaded to a device matches what you specified. If the downloaded file's hash does not match, the file will be removed from the device.*

Advanced Configuration

Advanced configuration allows you to stage your devices with one of more .xml files created by EZConfig or Enterprise Provisioner. For more information about generating .xml files, see the *Power Tools User Guide* or *Enterprise Provisioner User Guide*.

Note: *Advanced Configuration supports .xml files only. Other file types are ignored.*

Note: *Do not change the default names of .xml files. For example, DeviceConfig.xml is acceptable, but DeviceConfig1.xml is not.*

1. Choose one device to act as the server.
2. Tap **Settings > Honeywell Settings > Wi-Fi Staging** to launch Wi-Fi Staging on the server.
3. Tap **Advanced Configs**.
4. Tap **File directory**.
5. Specify where on the server device the .xml files to be downloaded are located.
6. Tap **NEXT**.

7. Choose the files to be applied. Tap **NEXT**.
8. Review the files you have selected. If you need to change any files, tap the Back button.

Otherwise, tap **Confirmed, start staging now!** to begin. Wi-Fi Staging starts a hotspot on the server device and waits for clients to connect.
9. Proceed to [Set Up Client Devices](#) on page 66.

Set Up Client Devices

The Wi-Fi Staging client runs automatically on the initial boot of a new device. However, it must be started manually on existing devices.

New Devices

This section applies to new, out-of-the box devices only. For existing devices, see [New Devices](#).

1. Set up a server device (see page 63).
2. Place the new devices to be configured within 1 meter (3 feet) of the server device and turn them on. When a new device boots up and begins the setup wizard, it attempts to retrieve configuration from the server device, and a staging progress screen appears.

Note: *Client devices should be kept on the Android Welcome or setup wizard screen during staging. If you finish the setup wizard manually, the client side of Wi-Fi Staging stops running.*

Configurations are distributed to any client that connects to the server device. Once data transmission finishes successfully, the name and serial number of the configured client appears in the Wi-Fi Staging app on the server device, and the client device skips the Android setup wizard.

Existing Devices

To start the Wi-Fi Staging client on an existing device:

1. Set up a server device (see page 63).
2. Tap **Settings** > **Honeywell Settings** > **Wi-Fi Staging** to turn on the client device and launch the Wi-Fi Staging app.
3. Tap **To be Staged**.
4. A message appears notifying you that the Wi-Fi settings on the client device will be reset as part of the staging process. Tap **OK** to confirm you wish to proceed.

Staging begins and a progress screen appears.
5. Place the device within 1 meter (3 feet) of the server device and it begins searching the server hotspot for a configuration.

The client device(s) attempt to retrieve the configuration from the server device and displays the staging progress screen. Once the client device receives and applies the configuration successfully, the progress screen is dismissed.

Note: *To stop the staging process on an existing device, tap the Back button on the client device.*

Log Files

Wi-Fi Staging saves a key process and exception log on the device in the following directory: /sdcard/honeywell/Android/data/com.honeywell.wifistaging/Log/

This directory can be accessed via a file browser on a workstation (e.g., laptop, desktop computer) through a USB file transfer connection with the mobile computer, if Provisioning Mode is enabled.

About Voice Wedge

Voice Wedge is a voice-to-text conversion tool that can be triggered by a specified start word or key press event. When Voice Wedge is activated, the mobile device can capture a user's speech and output it as text in a field in the selected app. Voice Wedge can be configured to apply globally across all apps or only for an associated application.

Note: *Because Voice Wedge is powered by Google speech recognition services, it is only available on Google Mobile Services (GMS) devices.*

Define Trigger Mode

You can define either a spoken word or a key press as the trigger to launch Voice Wedge.

1. Select **Settings > Honeywell Settings > Voice Wedge**.
2. Tap **Trigger Mode**.
3. Tap **Start Word** to define a voice command as the trigger or **Key** to use a key press.
4. If you selected Start Word, tap **Trigger start word** then use the keypad to enter the word. The default trigger start word is "honeywell".
5. If you selected Key, tap **Trigger key** then select the key to be mapped. You can either press a button, for example, a scan button, or use a virtual key. Note that when a button or key is selected for Voice Wedge, its original use is no longer active.

Associate Applications

By default, Voice Wedge is associated with all applications. You have the option to associate Voice Wedge with a single app.

1. Select **Settings > Honeywell Settings > Voice Wedge**.
2. Tap **Effective Coverage**.
3. Tap **Single app**.
4. Tap **App package name**.
5. Use the keyboard to enter the associated package name, for example, “com.android.chrome”, then click **OK**.
6. To limit Voice Wedge to a specific activity within an app, tap **App activity name** and use the keyboard to enter the activity name, for example, “com.google.android.apps.chrome.Main”.

Define Key Commands

Voice Wedge allows you to define some words so that they will be interpreted as commands rather than being displayed as text when you are speaking. When you say one of these words, Voice Wedge will send a key press.

Under **Key command**, select the check box for words that should be used as keys.

- Enter - When you say, “enter,” an Enter key will be sent.
- Tab - When you say, “table,” a Tab key will be sent.
- Space - When you say, “space,” a space key will be sent.

Select Data Type

By default, Voice Wedge enters both alphabetic and numeric characters. You can also choose to input only alpha or numeric characters.

1. Select **Settings > Honeywell Settings > Voice Wedge**.
2. Tap **Data type**.
3. Tap the data type to input.

Examples:

Data Type	You say...	Voice Wedge inputs...
Any	abc123	abc123
Alpha	abc123	abc
Numeric	abc123	123

To Use Voice Wedge in an App

Follow these steps to use Voice Wedge in an application on your device. Note that if a specific application is defined in the App Package Name setting, Voice Wedge will only work if you are using that app.

1. Select an app on your device.
2. Tap a data entry field in the app.
3. Say the defined Trigger start word or press the Trigger key.
A message indicates, "Waiting for voice input..."
4. Speak normally into the device.
The text will populate the selected field.

ABOUT THE VM DOCKS

Use this chapter to learn about the available docks for the VM1A.

About the Docks

The Thor computer assembly consists of two parts: the VM1A computer and the dock. The computer contains an internal UPS battery that, once fully charged, powers the computer for approximately 30 minutes when the unit is not mounted in the dock.

There are three available vehicle-mount docks:

- [VM1D Standard Dock](#)
- [VM3D Enhanced Dock](#)
- [Enhanced Dock with Thor VX8/VX9 Screen Blanking](#)

Additionally an off-vehicle dock is available for the computer for use in environment such as an office where AC power is available:

- [VMXD Enhanced Dock for Off-Vehicle Use](#)

All docks provide:

- A mount for the computer. The dock attaches to a vehicle via a RAM or U bracket mount or to a RAM table stand for use in an office environment.
- Conditioned power for the VM1A. The vehicle-mount docks accept 10-60VDC power input directly or 50-150VDC power input with a DC/DC converter. The off-vehicle dock requires an AC/DC power supply.
- Mobility of the VM1A, since the dock remains attached to the vehicle the computer can easily be moved from one vehicle equipped with a dock to another.
- I/O ports.
- Strain relief provisions for cables.
- Headset connection via an adapter cable. When a headset is not attached, the microphone and speakers are active.

Dock Overview

VM1D Standard Dock



Caution: In order to comply with US power efficiency requirements this dock should not be used in the US for AC power applications.

SKUs	VM1001VMCRADLE (with power cable) VM1002VMCRADLE (with RAM ball) VM1003VMCRADLE
Serial Ports	COM1 and COM2 by means of DB9 male connectors
USB Ports	USB port provides host connection via an adapter cable
Ethernet	N/A
Audio	Headset connection via an adapter cable
Screen Blanking	Supported via COM1 and COM2 connectors
Ignition Control	Supported

VM3D Enhanced Dock



Caution: In order to comply with US power efficiency requirements this dock should not be used in the US for AC power applications.

SKUs	VM3001VMCRADLE
Serial Ports	COM1 and COM2 by means of DB9 male connectors
USB Ports	USB1 port provides host connection via an adapter cable USB2 port provides two USB host ports via an adapter cable Direct USB host type A connection
Ethernet	RJ-45 Ethernet connection on top of dock
Audio	Headset connection via an adapter cable
Screen Blanking	Supported via COM1 and COM2 connectors
Ignition Control	Supported

Enhanced Dock with Thor VX8/VX9 Screen Blanking

This dock is designed for use when the Thor VM1A is replacing a Thor VX8 or Thor VX9. This dock utilizes the existing vehicle wiring from the earlier computer and supports screen blanking through that wiring.

SKUs	VMX004VMCRADLE
Power Connection	Direct or DC/DC power supply
Serial Ports	COM1 and COM2 by means of DB9 male connectors (See note below)
USB Ports	USB1 port provides host connection via an adapter cable USB2 port provides two USB host ports via an adapter cable Direct USB host type A connection
Ethernet	RJ-45 Ethernet connection on top of dock
Audio	Headset connection via an adapter cable
Screen Blanking	Supported via COM1 and COM2 connectors
Ignition Control	Not supported

Note: For the VMX Enhanced Dock: COM1 is used for screen blanking (via the power cable connector) and is unavailable when the screen blanking box is attached. When a screen blanking box is attached, any external serial device, such as a scanner, must be connected to the COM2 port on the dock. If a screen blanking box is not connected via the power cable, the COM1 port on the dock is available for a serial device.

VMXD Enhanced Dock for Off-Vehicle Use



Caution: This dock is designed for AC power (non vehicle-mounted) applications only.

SKUs	VMX005VMCRADLE
Power Connection	AC/DC adapter
Serial Ports	COM1 and COM2 by means of DB9 male connectors
USB Ports	USB1 port provides host connection via an adapter cable USB2 port provides two USB host ports via an adapter cable Direct USB host type A connection
Ethernet	RJ-45 Ethernet connection on top of dock
Audio	Headset connection via an adapter cable
Screen Blanking	Not supported
Ignition Control	Not supported

Features of the Dock

Front View - Dock

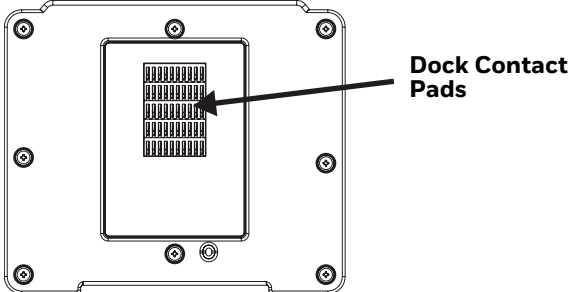

Back View - Dock

The connectors on the back of the dock vary by dock model.

Standard Dock

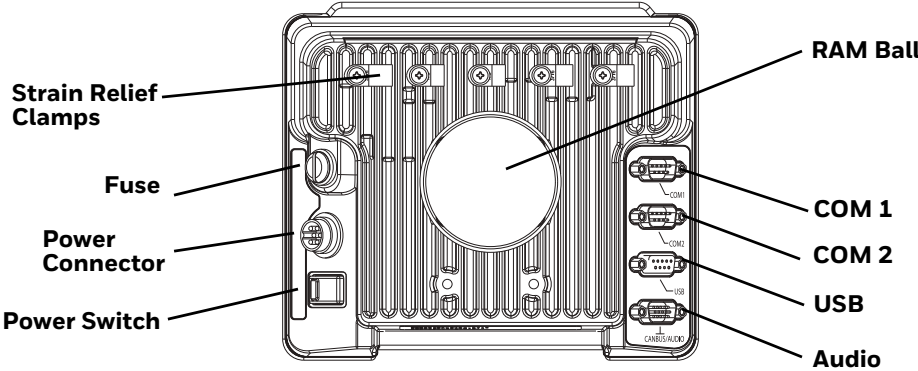

Enhanced Dock

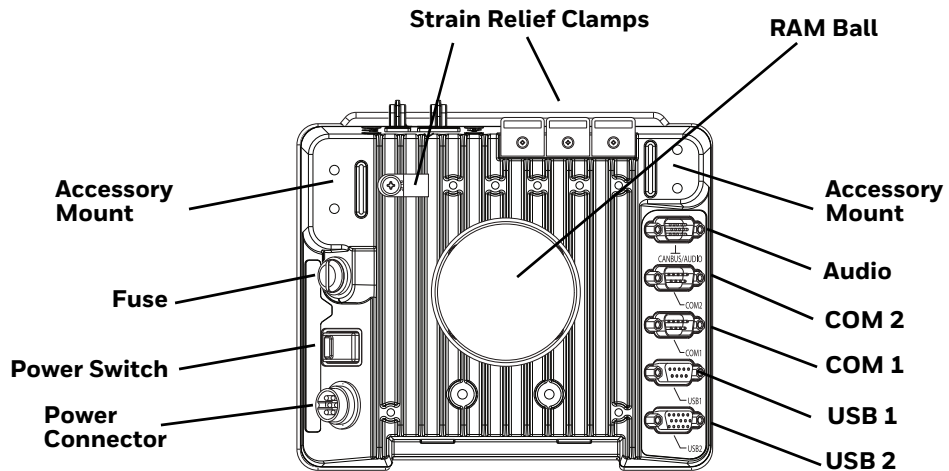

Note: For the VMX Enhanced Dock: COM1 is used for screen blanking (via the power cable connector) and is unavailable when the screen blanking box is attached. When a screen blanking box is attached, any external serial device, such as a scanner, must be connected to the COM2 port on the dock. If a screen blanking box is not connected via the power cable, the COM1 port on the dock is available for a serial device.

Top View - Enhanced Dock

Only the Enhanced Dock has these connectors on the top. The connectors are located behind the dust plugs.

Note: Dock USB Client Port is not supported with VM1A computers.

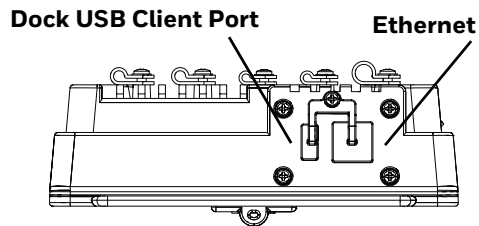

Dock I/O Pin Cover

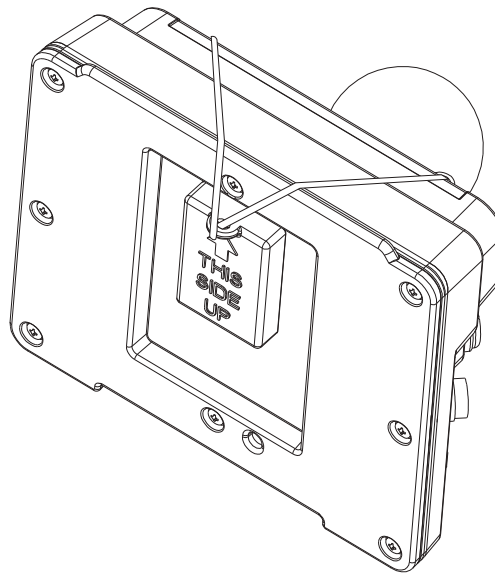

- When the computer is not installed in the dock, use the I/O Pin Cover to protect the pins on the dock, as shown.
- When the computer is installed in the dock, the I/O Pin Cover can be placed out of the way behind the dock.

Padlock

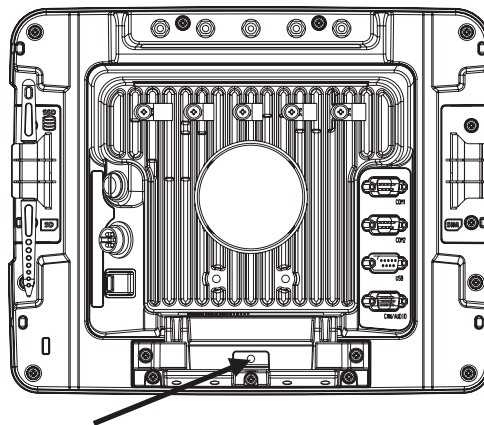

It may be desirable to secure the VM1A in the dock so it cannot be removed from the dock. The quick release handle on the computer is notched to allow a user supplied small padlock to be placed through a hole in the bracket on the back of the computer in the location shown below. Once the padlock is installed, the release handle cannot be moved so the VM1A cannot be removed from the dock. The padlock shackle must be smaller than 3/16" (4.76mm).

A cable tie wrap can be used instead of a padlock, if desired.

Laptop Security Cable

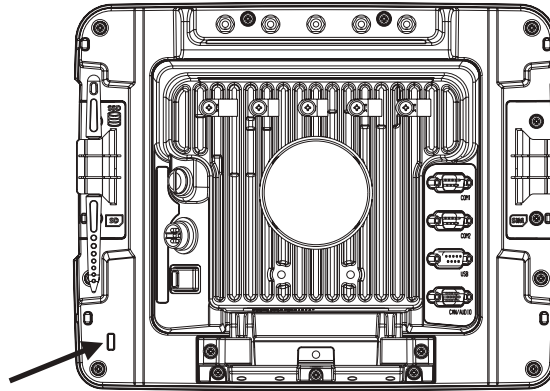

The VM1A can be secured with a standard laptop security cable using the slot on the back.

External Connectors Overview

- Power the VM1A Off before attaching a cable to any port (serial, USB, Audio, etc.).
- The external I/O connectors for the computer are located on the right side of the dock (when viewed from the back).
- The [Power Supply Connector](#) is on the left side of the dock (when viewed from the back).
- Antenna connectors are located on the top rear of the computer.

Serial Connector (COM1 and COM2)

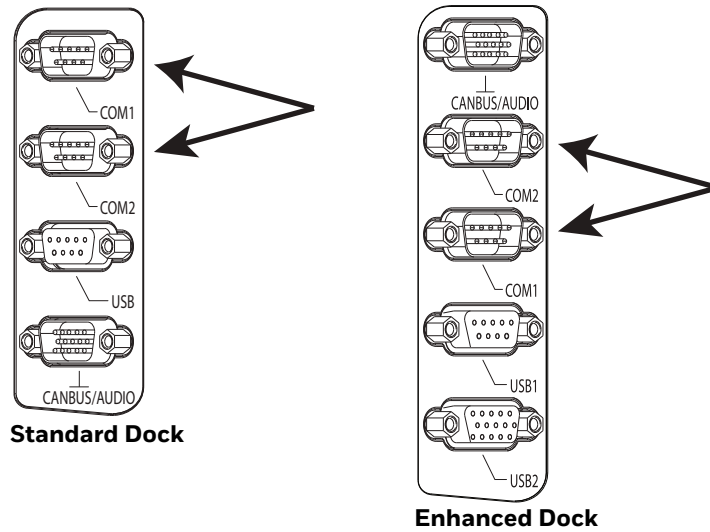

- The COM1 and COM2 connectors are D-9 male connectors located on the back of the dock.
- Power the VM1A Off before attaching a cable to any port (serial, USB, Audio, etc.).
- The serial connectors are industry standard RS-232, PC/AT standard 9-pin “D” male connector. See [COM1 and COM2 Connector](#) for connector pinout detail.
- Pin 9 is configured to provide +5V, 500mA for an external barcode scanner.
- See [Connect Serial Device](#) for more information.
- If a COM port is not being used for a peripheral, it can be used for [Screen Blanking Installation](#) when the vehicle is in motion.

USB Connector(s)

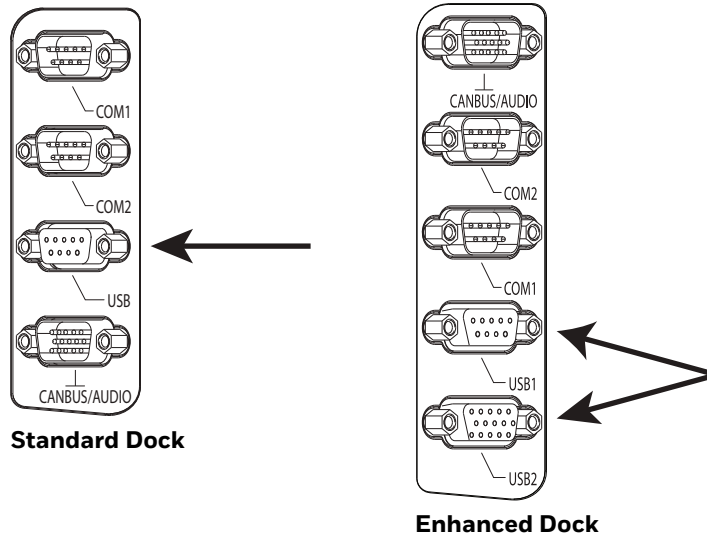

- The USB or USB1 connector is a D-9 female connector located on the back of the dock. See [USB and USB1 Connector](#) for connector pinout detail.
- See [Connect USB Host](#) for more information.
- The USB-2 connector is a D-15 female connector located on the back of the dock. See [USB2 Connector](#) for connector pinout detail.
- Power the VM1A Off before attaching a cable to any port (serial, USB, Audio, etc.).

Ethernet Connector

An Ethernet port is located on the top of the Enhanced Dock. Lift the cover to access the Ethernet port.

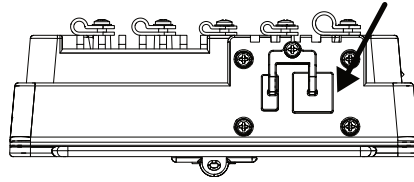

Audio Connector

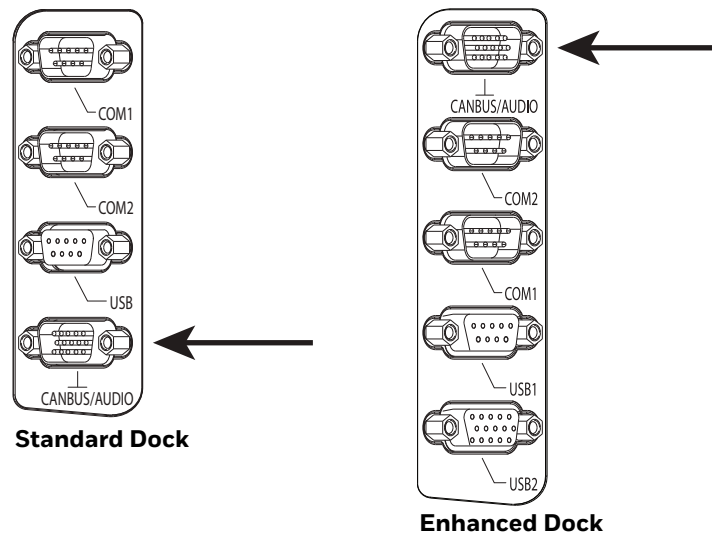

- The Audio connector is a D-15 male connector located on the back of the dock.
- See [Audio Connector](#) for connector pinout detail.
- A headset cable attaches to the Audio connector and provides a quick connect connection for a headset. See [Connect Headset Cable](#) for more information.

Power Supply Connector

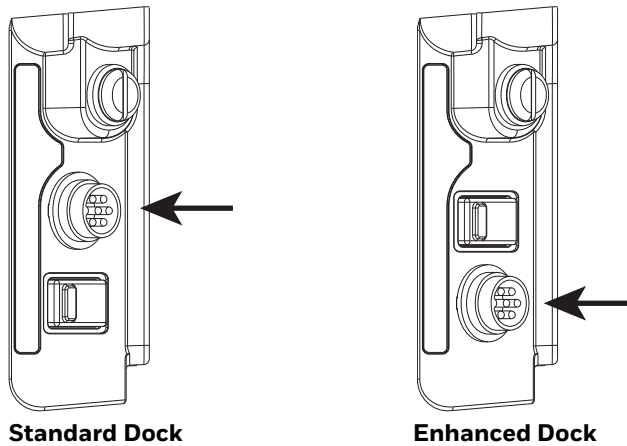

- Power is supplied to the VM1A through the power connector. Additionally, this assembly provides a connection point for the vehicle’s chassis ground to be connected internally to the conductive chassis of the computer.
- The computer’s internal power supply can accept DC input voltages in the range of 10 to 60 Volts DC when using the VM1D standard dock or VM3D enhanced dock. The VMXD dock DC input voltage is 13.2VDC from the AC/DC power supply.
- See [Power Supply Connector](#) for connector pinout detail. See [Connect Power](#) for more information on connecting power to the VM1A.

Antenna Connections

The VM1A is equipped with an 802.11 WLAN radio and can be ordered with internal antennas or configured to support external antennas. When the computer is ordered with internal antennas, the external antenna connectors are not used.

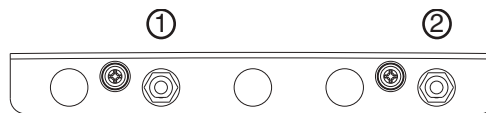

1. WI-FI (MAIN) (Red label) 802.11 Main External SMA Antenna Connector
2. WI-FI (AUX) (Yellow label) 802.11 Auxiliary External SMA Antenna Connector

External Antenna Connector

When the VM1A is ordered with the internal antenna option, the 802.11 antenna connectors on the back are not connected to the 802.11 radio. Instead the internal antenna connector is connected to the 802.11 radio.

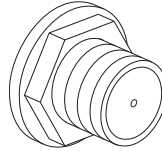

Remove the rubber cap, if present, from the antenna connector before connecting an external antenna.

Internal 802.11 Antennas

If the internal 802.11 antenna option is ordered, antennas are mounted inside the computer. The internal antennas are not user accessible.

External Antennas

The external antennas can be remotely mounted on the vehicle (VM1277AN-TENNA) or connected directly to the SMA connectors on the VM1A (VM2276AN-TENNA). See [Mount the 802.11 Remote Antenna](#) for instructions.

MOUNTING AND INSTALLING

Use this chapter to learn how to mount the VM1A.

About Mounting the VM1A



Warning: The correct dock must be selected for the installation:

- For a vehicle installation with 10-60 VDC direct connection: Use either a VM1D standard dock or a VM3D enhanced dock.
- For a vehicle installation with 60-144 VDC connection: Use a DC/DC power supply with either a VM1D standard dock or a VM3D enhanced dock.
- To replace a Thor VX8 or Thor VX9 on a vehicle: Use the existing power supply, if applicable, and the existing power cable with either a VM1D standard dock or VM3D enhanced dock.
- To replace a VX6, VX7, or CV61: Use the appropriate adapter power cable and either a VM1D standard dock or a VM3D enhanced dock. Voltage must be 10-60 VDC.
- For an AC powered application: Use an AC/DC power supply and the VMXD off-vehicle enhanced dock.

The VM1A is designed to be mounted to a dock in a vehicle with either a RAM mount or U Bracket system. A power cable is provided with some dock models. An integrated scanner mount is also offered. Optional communication cables are available.

Vehicle mounting brackets are specifically designed for vehicle mount applications. The vehicle mounted assembly restrains the VM1A and isolates it from shock and vibration. A RAM metal table stand is also available to secure the computer and dock when in an office environment.

The vehicle mount holds the dock and the VM1A attaches to the dock. The dock remains attached to the vehicle, however, the computer has a quick release located on the lower rear side that allows the computer to easily be removed from the dock.

The computer can be operated for approximately 30 minutes from an internal UPS battery when not attached to a dock. The computer can be transferred from one dock equipped vehicle to another for easy portability. The dock provides accessory attachment and conditioned power for the computer.

Overhead, dash, and roof support pillar mounting is via a RAM Mount or U-bracket accessory which includes most of the hardware required for vehicle mounting.



Warning: Never put the computer into the vehicle mounted assembly until the assembly is securely fastened to the vehicle.

Select Mounting Location

The VM1A should be secured to an area in the vehicle where it:

- Does not obstruct the driver's vision or safe vehicle operation.
- Will be protected from rain or inclement weather.
- Will be protected from extremely high concentrations of dust or wind-blown debris.
- Can be easily accessed by a user seated in the driver's seat while the vehicle is not in operation.

General Mounting Outline

The following list outlines, in a general way, the process to follow when mounting the VM1A in a vehicle.

1. [Install RAM Mount](#) or [Install U Bracket Mount or Adapter](#) to the vehicle
2. [Place Thor VM1A in the Dock.](#)
3. Secure accessories, such as, a scanner holder, to either and integrated or remote mounting bracket.
4. Adjust the computer to the best viewing angle.
5. [Mount the 802.11 Remote Antenna](#), if necessary.
6. Connect power for any peripherals.
7. Connect vehicle power:
 - [12-48 VDC Vehicles \(10-60 VDC Direct Connection\)](#)
 - [60-144 VDC Vehicles \(50-150 VDC Power Supply, Screws on Top of Lid\)](#)
 - [60-144 VDC Vehicles \(50-150 VDC Power Supply, Screws on Side of Lid\)](#)
 - [Thor VX8/Thor VX9 Adapter Cable](#)
 - [VX5/VX6/VX7 Adapter Cable](#)
8. Secure all cables in [Strain Relief Cable Clamps](#).

The VM1A is ready for use.

Install RAM Mount



Caution: This device is intended to transmit RF energy. For protection against RF exposure to humans and in accordance with FCC rules and Industry Canada rules, this transmitter should be installed such that a minimum separation distance of at least 20 cm (7.8 in.) is maintained between the antenna and the general population. This device is not to be co-located with other transmitters.

Step 1. Before installation begins, verify you have the applicable vehicle mounting assembly components necessary. Refer to the Thor VM Series Vehicle Mount Computer Accessory Guide for information on RAM mount kits and components on www.honeywellaidc.com. Kits do not include the hardware required to mount the base to the vehicle since requirements vary from vehicle to vehicle.

Step 2. You will need the following tools for mounting the RAM:

- Sockets
- Ratchet wrench
- Screwdriver
- Drill and bits, if using a round or place base
- Torque wrench capable of torquing to 20 inch pounds (1.10 N/m).

For these nuts...	Torque to
10-32 lock nuts	17-20in/lb (0-95 - 1.10 N/m)

Note: Tools are not supplied by Honeywell.

Step 3. Attach the base to the vehicle.

RAM Ball Mount

1. Determine the position for mounting the RAM ball base. Be sure to position the RAM bracket to allow access to the switches and ports on the bottom of the computer.

Note: Mount to the most rigid surface available.

2. Drill and tap holes for three 1/4 bolts. (Drawing not to scale.)

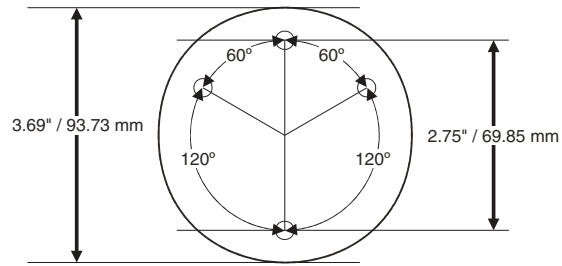

3. Attach the RAM ball base to the vehicle mounting surface using three or four 1/4 bolts (not included) or equivalent fasteners. If the mounting kit includes cone washers, use those as illustrated below.

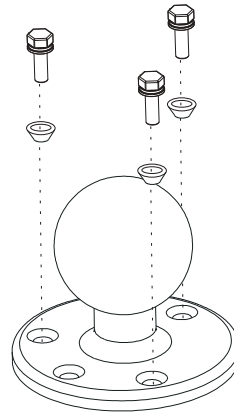

RAM Clamp Mount

1. Determine the position for mounting the RAM clamp mount. The clamp mount can be used on a beam (such as on a fork lift truck) up to 2.5" (63.5 mm) wide and approximately 2" (50.8 mm) thick. The clamp may be attached to a thicker beam by substituting longer bolts (not included). Be sure to position the RAM clamp mount to allow access to the switches and ports on the bottom of the computer. (Drawing not to scale.)

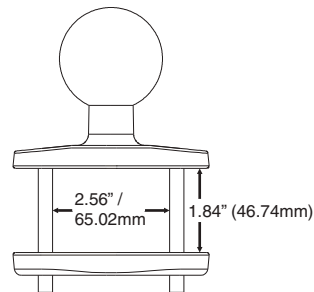

2. Position the upper clamp piece with ball on the beam. Place the bolts through the holes in the upper clamp piece. Position the lower clamp piece below the beam. Align the bolts with the holes in the lower clamp piece. Place the nylon locking nuts on the bolts and tighten the bolts.

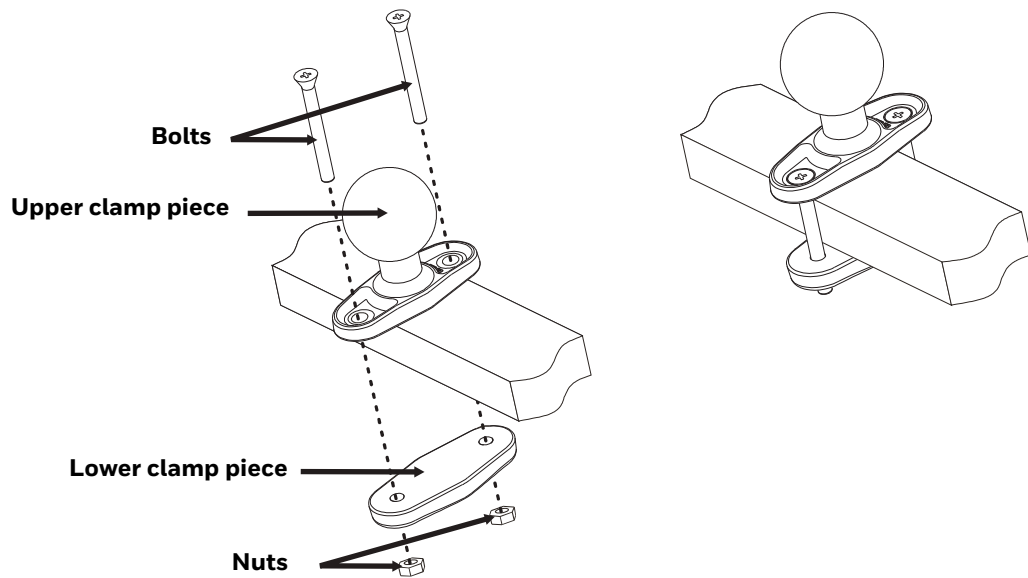

RAM Plate Mount with RAM Ball

1. Determine the position for mounting the RAM ball plate. Be sure to position the RAM plate to allow access to the switches and ports on the bottom of the computer.

Note: Mount to the most rigid surface available.

2. Attach the RAM ball plate to the vehicle mounting surface using four 1/4 bolts (not included) or equivalent fasteners. (Drawing not to scale.)

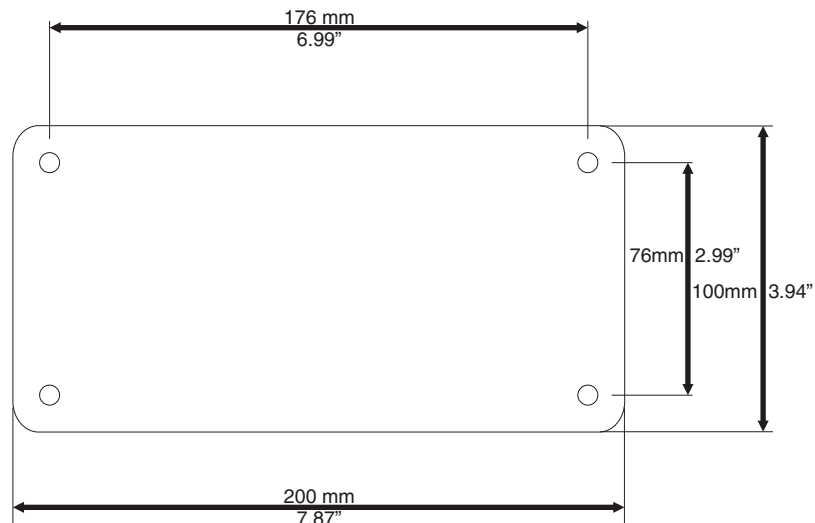

3. If not already attached, attach the RAM ball to the RAM ball plate using three M6 nuts and washers.

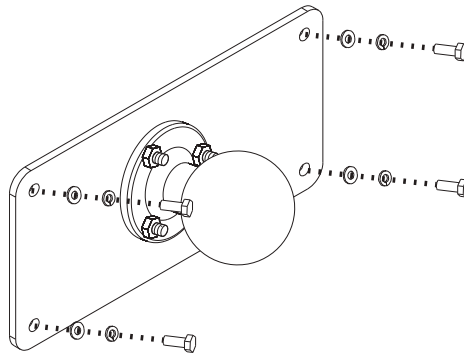

Attach RAM Mount Ball to the Dock

1. Turn the computer off before attaching the RAM mount ball.
2. Place the computer face down on a stable surface.
3. Position the RAM ball on the rear of the dock, aligning the holes on the back of the dock with the holes on the RAM ball base. Attach with four M5 screws, flat washers and lock washers.

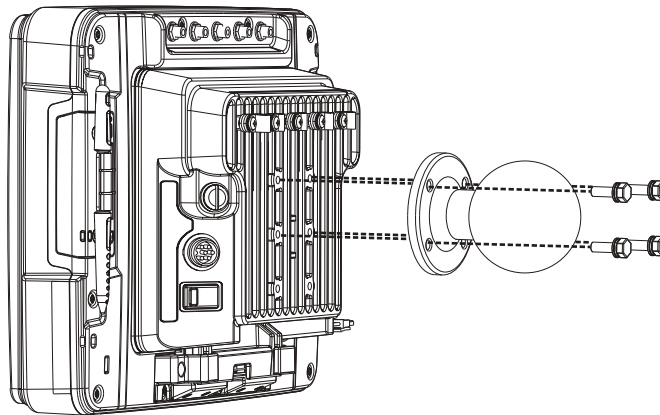

Attach Thor VM1A Assembly to RAM Mount

1. Slip the Size D RAM arm over the ball on the vehicle RAM mount (RAM Ball mount shown).
2. Insert the ball on the dock into the RAM arm and tighten the knob on the RAM arm.

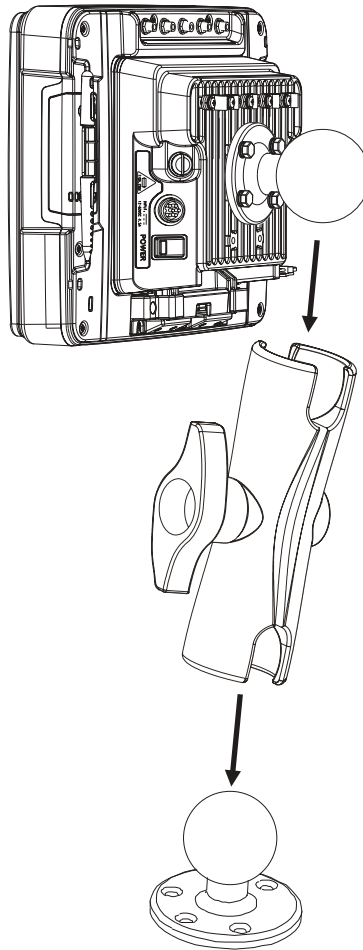

Step 3. Place the computer onto the dock.

Step 4. Attach the optional scanner holder to the Enhanced Dock.

1. Attach the accessory RAM ball to Enhanced Dock. There are two mounting provisions, one on either side of the Enhanced dock and either can be used to mount the scanner holder. (Some components omitted for detail clarity.)

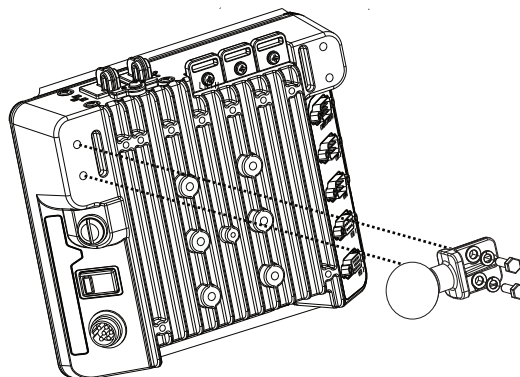

2. Attach the RAM ball to the back of the scanner holder.