

<b>Prüfbericht-Nr.:</b> <i>Test report no.:</i>	IN23ZC8W 001	<b>Auftrags-Nr.:</b> <i>Order no.:</i>	146742972 0010	Seite 1 von 50 Page 1 of 50	
<b>Kunden-Referenz-Nr.:</b> <i>Client reference no.:</i>	2119359	<b>Auftragsdatum:</b> <i>Order date:</i>	2022-12-06		
<b>Auftraggeber:</b> <i>Client:</i>	HONEYWELL INTERNATIONAL INC, Honeywell Safety and Productivity Solutions 9680 OLD BAILES RD, FORT MILL, SC 29707, USA				
<b>Prüfgegenstand:</b> <i>Test item:</i>	HWBPC11AX-PRTM	<b>Product Type</b>	Wi-Fi BT Module		
<b>Bezeichnung:</b> <i>Identification .:</i>	HWBPC11AX-PRT				
<b>Auftrags-Inhalt:</b> <i>Order content:</i>	Testing and issue of Test Report and Grant Certificate				
<b>Prüfgrundlage:</b> <i>Test specification:</i>	FCC Part 15 Subpart C 15.247, 15.207, 15.205 & 15.209 RSS 247 Issue 2 and RSS GEN Issue 5				
<b>Wareneingangsdatum:</b> <i>Date of sample receipt:</i>	2022-12-07				
<b>Prüfmuster-Nr &amp; Serien-Nr.:</b> <i>Test sample no &amp; serial no.:</i>	A003385546-022 & A003385546-04 2022120701 & 2022120702				
<b>Prüfzeitraum:</b> <i>Testing period:</i>	2022-12-07 - 2023-01-06				
<b>Ort der Prüfung:</b> <i>Place of testing:</i>	Wireless laboratory, Bangalore				
<b>Prüflaboratorium:</b> <i>Testing laboratory:</i>	TÜV Rheinland (India) Pvt.Ltd., 27/B, 2nd Cross, Electronic City Phase1 Bangalore -560 100, India FCC Test site registration number: 496599 ISED Test site registration number: 3466E-1				
<b>Prüfergebnis*:</b> <i>Test result*:</i>	Pass				
<b>geprüft von:</b> <i>tested by:</i>	<b>genehmigt von:</b> <i>authorized by:</i>				
<b>Datum:</b> <i>Date:</i> 2023-01-09	<b>Ausstellatum:</b> <i>Issue date:</i> 2023-02-28				
<b>Stellung / Position:</b>	<b>Likhithesh M D</b> Senior Engineer	<b>Stellung / Position:</b>	<b>Madhu K.N</b> Senior Engineer		
<b>Sonstiges / Other:</b>	FCC ID: HD5-PC11AX IC: 1693B-PC11AX				
<b>Zustand des Prüfgegenstandes bei Anlieferung:</b> <i>Condition of the test item at delivery:</i>	<b>Prüfmuster vollständig und unbeschädigt</b> <i>Test item complete and undamaged</i>				
* Legende:	1 = sehr gut P(ass) = entspricht o.g. Prüfgrundlage(n)	2 = gut F(ail) = entspricht nicht o.g. Prüfgrundlage(n)	3 = befriedigend F(ail) = entspricht nicht o.g. Prüfgrundlage(n)	4 = ausreichend N/A = nicht anwendbar	5 = nicht befriedigend N/T = nicht getestet
* Legend:	1 = very good P(ass) = passed a.m. test specification(s)	2 = good F(ail) = failed a.m. test specification(s)	3 = satisfactory F(ail) = failed a.m. test specification(s)	4 = sufficient N/A = not applicable	5 = poor N/T = not
<p><b>Dieser Prüfbericht bezieht sich nur auf das o.g. Prüfmuster und darf ohne Genehmigung der Prüfstelle nicht auszugsweise vervielfältigt werden. Dieser Bericht berechtigt nicht zur Verwendung eines Prüfzeichens.</b> <i>This test report only relates to the a. m. test sample. Without permission of the test center this test report is not permitted to be duplicated in extracts. This test report does not entitle to carry any test mark.</i></p>					

**Prüfbericht - Nr.:**  
Test Report No.:

**IN23ZC8W 001**

Seite 2 von 50  
Page 2 of 50

## TEST SUMMARY

Test Item	Applicable Standard		Result
	FCC	ISED	
Maximum conducted (Peak) output power	FCC 15.247(b)(1)	RSS 247 Issue 2, Section 5.4 (b)	Pass
Maximum Power Spectral Density	FCC 15.247(e)	RSS 247 Issue 2, Section 5.2 (b)	NA
DTS Bandwidth	FCC 15.247(a)(iii)	RSS 247 Issue 2, Section 5.1 (b)	Pass
Channel Frequency Separation	15.247(a)(1)	RSS 247 Issue 2, Section 5.1 (b)	Pass
Number of Hopping Channels	15.247(a)(iii)	RSS 247 Issue 2, Section 5.1 (d)	Pass
Time of Occupancy(Dwell Time)	15.247(a)(iii)	RSS 247 Issue 2, Section 5.1 (d)	Pass
Emissions in non-restricted frequency bands	FCC 15.247(d)	RSS 247 Issue 2, Section 5.5	Pass
Spurious Radiated Emissions and Restricted Bands of Operation	FCC 15.209 / FCC 15.205	RSS-Gen Issue 5, Section 8.9 /8.10	Pass
Conducted Emissions on a.c power Lines	FCC 15.207	RSS-Gen Issue 5, Section 8.8	Pass

Product Category: Electronics Testing  
Test Discipline: EMC Test Facility

### Compliance statement for Part 15.203:

“THE ANTENNA WITH A STANDARD CONNECTOR (U.FL) USED, WITH NO POSSIBILITY OF REPLACEMENT WITH A NON-APPROVED ANTENNA BY THE END-USER. THEREFORE, THE EUT IS CONSIDERED TO COMPLY WITH THIS PROVISION.”

**Prüfbericht - Nr.:**  
*Test Report No.:*

**IN23ZC8W 001**

Seite 3 von 50  
Page 3 of 50

## REVISION HISTORY OF THIS REPORT

Report Number	Version	Description	Issue date
IN23ZC8W 001	01	Initial Issue of Test Report	14-02-2023
IN23ZC8W 001	02	Reviewer comments updated	28-02-2023

## Table of Contents

1	GENERAL REMARKS .....	5
1.1	Attachments .....	5
2	TEST SITES .....	6
2.1	Testing Facilities.....	6
2.2	List of Test and Measurement Instruments.....	6
3	GENERAL PRODUCT INFORMATION.....	7
3.1	Product Function and Intended Use.....	7
3.2	Ratings and System Details of Equipment under Test .....	7
3.3	Measurement Uncertainty: .....	8
4	TEST SET-UP AND OPERATION MODE .....	9
4.1	Principle of Configuration Selection .....	9
4.2	UUT Operation and Software .....	9
4.3	Special Accessories and Auxiliary Equipment .....	9
4.4	Simultaneous Transmission .....	9
4.5	Countermeasures to achieve EMC Compliance .....	9
4.6	List of frequencies .....	9
4.7	Report references.....	10
5	OPERATIONAL DESCRIPTION.....	11
6	TEST METHODOLOGY .....	12
6.1	Conducted Spurious Emission Test on AC Power Line.....	12
6.1.1	Test Setup Configuration .....	12
6.2	Radiated Emission Test .....	13
6.2.1	Test Setup Configuration .....	13
7	TEST RESULTS FOR BLUETOOTH .....	15
7.1	Maximum Peak Conducted Output Power .....	15
7.2	20dB Bandwidth & 99% Bandwidth.....	18
7.3	Number of Hopping Channels.....	20
7.4	Carrier Frequency Separation.....	22
7.5	Time Of Occupancy(Dwell Time) .....	24
7.6	Emissions in non-restricted frequency bands and Conducted Spurious Emission.....	26
7.6.1	Reference plots .....	27
7.6.2	Band Edge.....	28
7.6.3	Out-Of-Band Emissions.....	29
7.7	Spurious Radiated Emissions & Restricted Bands of Operation .....	32
8	CONDUCTED SPURIOUS EMISSION TEST ON AC POWER LINE .....	47
9	LIST OF TABLES.....	50
10	LIST OF FIGURES.....	50
11	POWER LEVEL USED FOR TESTING .....	50

# 1 GENERAL REMARKS

## 1.1 Attachments

All attachments are part of this test report and are issued in separate document

- 1: TEST SETUP PHOTOS
- 2: EUT EXTERNAL PHOTOS
- 3: EUT INTERNAL PHOTOS
- 4: FCC LABEL AND LABEL LOCATION
- 5: BLOCK DIAGRAM
- 6: SPECIFICATION OF EUT
- 7: SCHEMATIC DIAGRAM
- 8: BILL OF MATERIAL
- 9: USER MANUAL
- 10: MAXIMUM PERMISSIBLE EXPOSURE INFORMATION

## 2 TEST SITES

### 2.1 Testing Facilities

1. TÜV Rheinland (India) Pvt.Ltd.,  
27/B, 2nd Cross,  
ElectronicCityPhase1  
Bangalore – 560 100,  
India

2. TUV Rheinland (India) Pvt.Ltd.,  
108 , Beside ISBR Business School,  
Electronic city Phase I  
Bangalore - 560 100.  
India

Radiated Measurement site type :  
Fully anechoic chamber (used for above 1 GHz  
measurements)

Radiated Measurement site type :  
Semi anechoic chamber (used for below 1 GHz  
measurements)

### 2.2 List of Test and Measurement Instruments

Table 1: List of test and measurement instruments

Equipment	Manufacturer	Model Name	Serial Number	Firmware Versions	Calibration Due Date	Periodicity	Test Facility
EMI Receiver	Rohde & Schwarz	ESW 44	101732	4.73 SP5	04.08.2023	Yearly	Radiated Spurious Emission
Active loop antenna	Frankonia	LAX-10	LAX-10-800	-	31.01.2023	Yearly	
Baloon and Biconical Antenna	Schwarzbeck mess-elektronik	VHBB-9124 / BBA-9106	01028	-	03.02.2023	Yearly	
Log-Periodic Antenna	Schwarzbeck mess-elektronik	VUSLP-9111B	9111B-111	-	26.01.2023	Yearly	
Horn Antenna	Schwarzbeck	BBHA 9120 D	9120D-01944	-	11.10.2023	Yearly	
EMI Test Receiver	Rohde & Schwarz	ESW44	101773	1.72.SP1	12.02.2023	Yearly	
Semi Anechoic Chamber	Frankonia	-	-	-	-	-	
Fully Anechoic Chamber	Albatross	-	-	-	-	-	Conducted Test Parameters
Spectrum Analyzer	Agilent	E4407B	US41192772	A.14.07	21-12-2023	Yearly	
10dB Attenuator	H+S Electronics Pvt. Ltd	6810.17.A	770041	-	19-03-2023	Yearly	
Signal Analyser	Rohde & Schwarz	FSV7	101644	FW 3.40	25-01-2023	Yearly	
Signal Analyser	Anritsu Corporation	MS2830A	6261983953	-	18-10-2023	Yearly	Conducted AC Power line Test
EMI Receiver	Rohde & Schwarz	ESR7	101133	3.48 SP3	22.07.2023	Yearly	
Line Impedance Stabilization Network	Rohde & Schwarz	ENV 216	101434	-	11.04.2023	Yearly	
Pulse Limiter	Rohde & Schwarz	ESH3-Z2	100811	-	12.07.2023	Yearly	

Table 2: Instrument application Software versions

SL. No.	Test Type	Application software	Version
1	Radiated spurious emission measurement in 10mtr-SAC	BAT EMC	3.20.0.17
2	Radiated spurious emission measurement in FAC	EMC 32	10.60.20

## 3 GENERAL PRODUCT INFORMATION

### 3.1 Product Function and Intended Use

**HWBPC11AX-PRTM** is a carrier board with System on Module. The module to be used inside the Honeywell Products. The Module has Dual Band WIFI (2.4GHz & 5GHz) and BLUETOOTH radio interface. This module communicates with external host using SDIO interface for WIFI and UART for BLUETOOTH.

This Module supports 802.11a/b/g/n/ac/ax for WIFI and Supports BT (Basic , EDR & BLE) The module will act as Access Point / Master only in NON - DFS bands. In the DFS band, the Module acts as Slave /Station device which do not have Radar detection functionality.

Powered with BM-57, **HWBPC11AX-PRTM** achieve the best possible connectivity and performance in RF Environment.

This Module will be used to provide the WIFI & BLUETOOTH wireless connectivity for Honeywell Products

### 3.2 Ratings and System Details of Equipment under Test

Table 3: Ratings and System Details as declared by Client\*

<b>Radio Protocol</b>	Bluetooth	
<b>Operating Frequency Range</b>	2402MHz to 2480MHz	
<b>No. of Channels</b>	79	
<b>Channel Spacing</b>	1MHz	
<b>Transmitting Power Level</b>	Refer clause 11	
<b>Maximum Measured Power (e.i.r.p)</b>	<b>1001932PT(Flex/PCB Antenna)</b> 19.88 dBm(1 Mbps 2440MHz)	
	<b>FPA3020-10A (Flex/PCB Antenna)</b> 21.61 dBm(1 Mbps 2440MHz)	
<b>Modulation</b>	GFSK, pi/4-DQPSK,8-DPSK	
<b>Number of antennas</b>	2	
<b>Antenna type &amp; gain</b>	1001932PT(Flex/PCB Antenna)	2.50dBi
	FPA3020-10A (Flex/PCB Antenna)	4.23dBi
<b>Supply Voltage to Product</b>	3.3VDC through AC/DC Adapter , <2A	
<b>Environmental conditions</b>	Storage	-20degC to +70degC Relative Humidity <95%
	Operating	-20degC to +60degC Relative Humidity <95%
<b>EUT Dimension</b>	2.5 x 2.5 x 0.3 CM (L x W x H)	

\***Disclaimer:** The information/data is supplied by the client and the same is considered to arrive at the final value. Any changes made apart from the specified specification, can directly impact on the tests results. Refer the products user manual for more details.

**Prüfbericht - Nr.:**  
*Test Report No.:*

**IN23ZC8W 001**

Seite 8 von 50  
Page 8 of 50

**Note:** Product **HWBPC11AX-PRTM** has multiple protocols. All the supported wireless protocols and their respective test results are issued in separate test reports, refer clause 4.7 Report references

### 3.3 Measurement Uncertainty:

Reported uncertainties represent expanded uncertainties expressed at approximately the 95% confidence level using a coverage factor of  $k = 2$

**Table 4: Measurement Uncertainty**

Parameter	Uncertainty
Occupied Channel Bandwidth	±5 %
RF output power, conducted	±1.5 dB
Power Spectral Density, conducted	±3 dB
Unwanted Emissions, conducted	±3 dB
All emissions, radiated	±6 dB
Temperature	±3 °C
Supply Voltages	±3 %
Time	±5 %

**Note:** The Listed Measurement Uncertainties are the worst-case uncertainty, for the respective test cases. Above Table is for reporting purpose only and not used in determining Final Pass/Fail verdict.



## 4 TEST SET-UP AND OPERATION MODE

### 4.1 Principle of Configuration Selection

Transmission was enabled with highest possible duty cycle on low, mid and high channels

### 4.2 UUT Operation and Software

Hardware Version Identification number (HVIN) : 3008-8482-001  
Software version : 18.35.387.23.1301.62

### 4.3 Special Accessories and Auxiliary Equipment

Test laptop (Tera Term VT ver 4.105),  
LAN cable

### 4.4 Simultaneous Transmission

This product does not supports Simultaneous transmission

### 4.5 Countermeasures to achieve EMC Compliance

- None

### 4.6 List of frequencies

Frequency Band (MHz)	Channel No.	Channel Frequency (MHz)
2400 – 2483.5 BT(BDR+EDR)	<b>0</b>	<b>2402</b>
	1	2403
	2	2404
	3	2405
	:	:
	:	:
	:	:
	37	2439
	<b>38</b>	<b>2440</b>
	39	2441
	40	2442
	:	:
	:	:
	:	:
	74	2476
	75	2477
	:	:
:	:	
<b>78</b>	<b>2480</b>	

Table 5: List of Bluetooth center Frequencies

#### Channel used for Bluetooth testing

Channel low : 2402MHz

Channel mid : 2440MHz

Channel high : 2480MHz

**Prüfbericht - Nr.:**  
*Test Report No.:*

**IN23ZC8W 001**

Seite 10 von 50  
Page 10 of 50

**Note:**

TUV Sample Identification number : A003385546-022 – Radiated test Sample  
A003385546-04 – Conducted test Sample

## 4.7 Report references

**Note:** Product **HWBPC11AX-PRTM** has multiple protocols. All the supported wireless protocols and their respective test results are issued in separate test reports, following table lists the report numbers.

<b>Radio Protocol</b>	<b>Report Number</b>
RF test report for Wi-Fi (2.4GHz) & BLE (2.4GHz)	IN2391GP 001
<b>RF test report for Bluetooth (2.4GHz) → This Report</b>	<b>IN23ZC8W 001</b>
RF test report for Wi-Fi (5GHz)	IN23VER9 001

## 5 OPERATIONAL DESCRIPTION

This **HWBPC11AX-PRTM** is a WiFi/BT system on module which will be placed inside the Honeywell products like printers, barcode scanners, RFID readers etc. to enable wireless connectivity. This module includes MAC & physical layer of 802.11a/b/g/n/ac and the Bluetooth modem.

This module operates on 5.0V DC Power supply with internal on board regulation to generate 3.3v for powering ON all the circuits. The entire RF circuits is enclosed in RF shield of dimension 25mm X 25mm.

The module uses internal power amplifier and LNA for 2.4GHz frequency band and an external front end chip for 5GHz frequency band. All filters and diplexers are included in the module to ensure maximum power flatness and optimum VSWR. The module has one antenna chain for 1X1 output.

The module supports range of data rates from 1Mbps in 802.11b mode to MCS9 in 802.11ac mode. This chipset also supports concurrent operation of Bluetooth (Version 5.0) for wireless connectivity during browsing or other device applications. Along with both standard and high speed (HS) Bluetooth data rates, Bluetooth low energy modes are also supported. Hardware WAPI acceleration engine, AES, TKIP, WPA and WPA2 are supported to provide the latest security requirement on your network.

The Device communicates with HOST using SDIO interface for WIFI and UART interface for BLUETOOTH.

## 6 TEST METHODOLOGY

### 6.1 Conducted Spurious Emission Test on AC Power Line

Measured levels of ac power-line conducted emission across the 50Ω LISN port (to which the EUT is connected). All emission voltage and current measurements shall be made on each current-carrying conductor at the plug end of the EUT power cord by the use of mating plugs and receptacles on the LISN, if used. Equipment shall be tested with power cords that are normally supplied or recommended by the manufacturer and that have electrical and shielding characteristics that are the same as those cords normally supplied or recommended by the manufacturer.

The device is placed on the test table, raised 80cm above the reference ground plane. The vertical conducting plane is located 40cm to the rear of the device. AC Conducted emission measurement is made over frequency range from 150kHz to 30MHz, this measurement was performed with EUT powered with an AC adaptor with 110V AC 60Hz supply.

#### 6.1.1 Test Setup Configuration

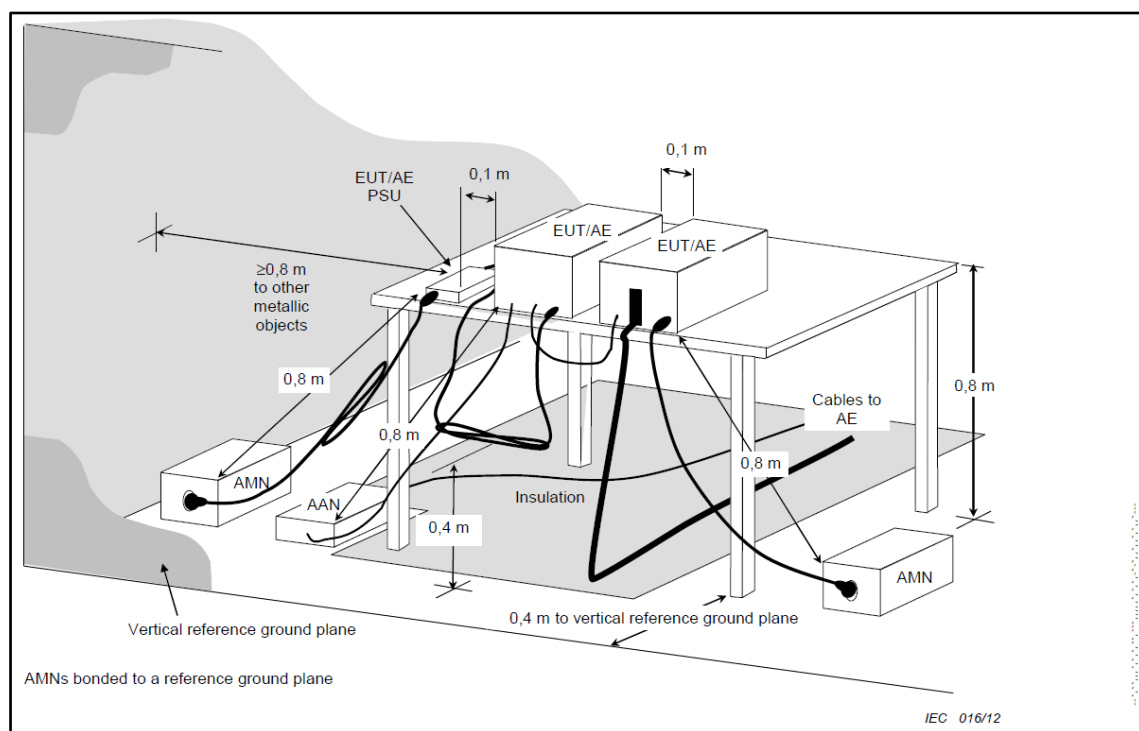

## 6.2 Radiated Emission Test

The radiated emission measurement was performed according to the procedures in ANSI C63.10-2013. The equipment under test (EUT) was placed at the middle of the 80 cm high turntable for below 1 GHz & 1.5 m height for above 1 GHz measurement, and the EUT is 3 meters far from the measuring antenna. The turntable was rotated 360° for obtaining the maximum emission. The height of the measuring antennas was scanned between 1 m and 4 m, and the antenna rotated to repeat the measurements for both the horizontal and vertical antenna polarizations. Repeat the measurement steps until the maximum emissions were obtained. The measurement above 1000 MHz was performed by horn antenna, The measurement below 30 MHz was performed by loop antenna, Measurement from 30 MHz to 200 MHz was performed by Baloon and Biconical Antenna, and mesurement from 200 MHz to 1 GHz was performed by Log-Periodic Antenna.

The EUT was rotated around the X-, Y-, and Z-Axis and the results from worst case axis are recorded

### 6.2.1 Test Setup Configuration

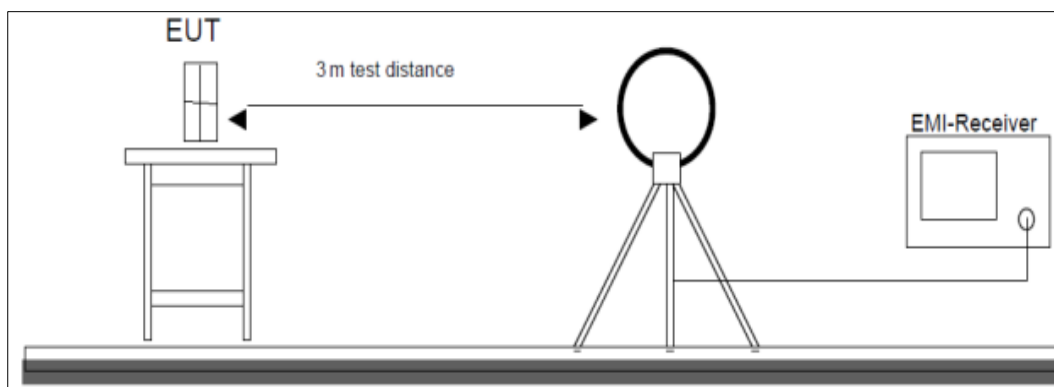

Figure 1: Frequency Range 9 kHz- 30 MHz

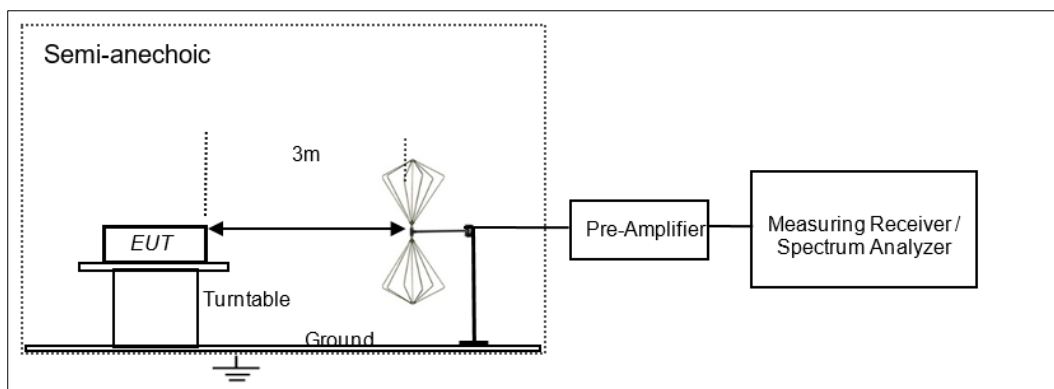

Figure 2: Frequency Range 30 MHz – 200 MHz

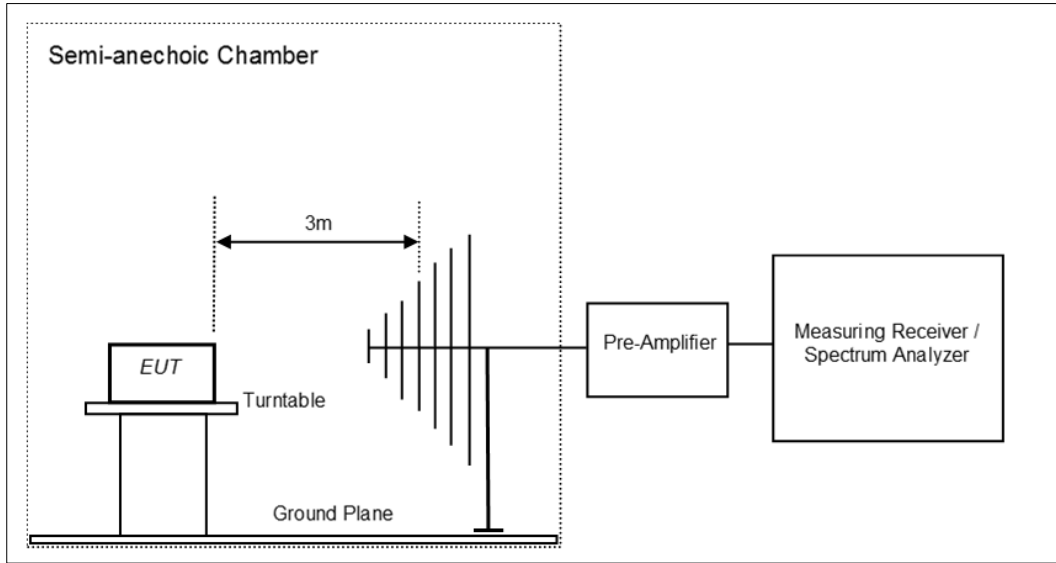

Figure 3: Frequency Range 200 MHz - 1GHz

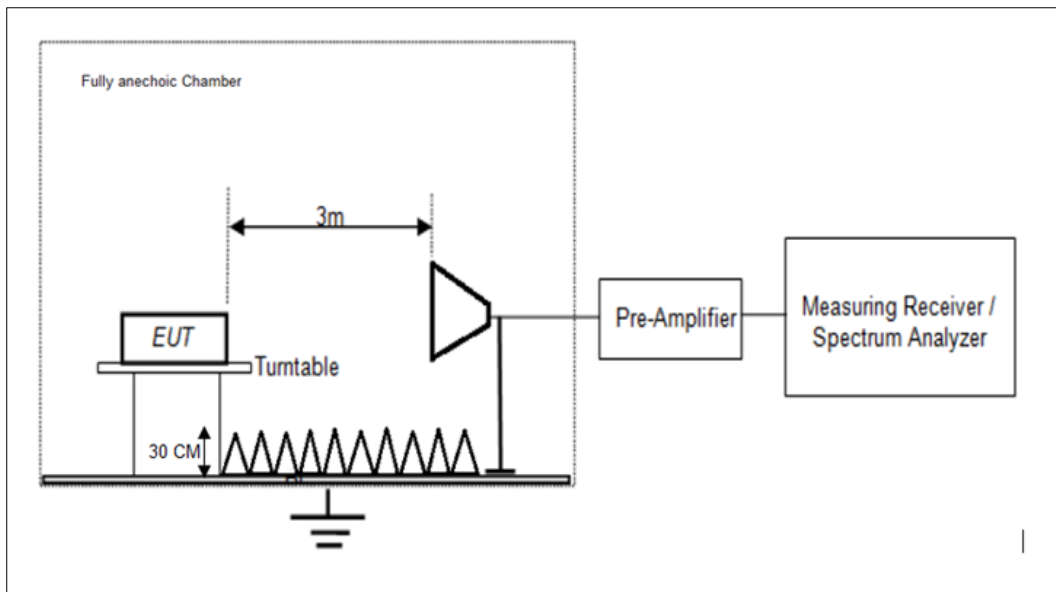

Figure 4: Frequency Range above 1 GHz

## 7 TEST RESULTS FOR BLUETOOTH

### 7.1 Maximum Peak Conducted Output Power

**Result**

**Pass**

Test Specification	FCC part 15 Subpart C 15.247 (b)(1) / RSS 247 Issue 2, Section 5.4 (b)
Test Method	Subclause 7.8.5 of ANSI C63.10
Measurement Bandwidth	1MHz
Detector	Peak
Port of testing	Antenna port
Requirement	Power $\leq$ 1 W (30 dBm) & e.i.r.p $\leq$ 4 W (36 dBm)

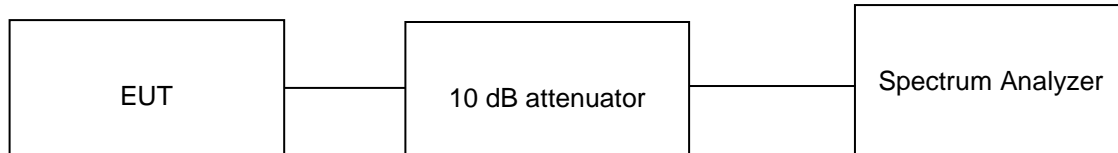

#### Test Condition

##### Normal Test Condition:

Temperature (Norm) = + 22.6 °C      Voltage = 3.3 V DC through AC to Dc adaptor      Relative humidity: 62%

#### KDB Guidelines applied:

Measurements were made as per section 9 b) in KDB 558074 D01 15.247 Measurement Guidance v05r02.

**Prüfbericht - Nr.:**  
Test Report No.:

**IN23ZC8W 001**

Seite 16 von 50  
Page 16 of 50

**Test results:**

**Note:**

1. All the losses are included during measurement and final values are mentioned in the test report.
2. Total Peak Output power (dBm) = Measured Peak power (dBm) + Attenuator factor (10dB) + Cable loss (1.4dB)

Antenna Type	Data Rate (Mbps)	Channel Frequency (MHz)	Maximum Peak Conducted Output Power (dBm)	Maximum (e.i.r.p)	Power Limit (dBm)	Limit (e.i.r.p)
1001932PT PCB/Flex Antenna	1	2402	16.35	18.85	30.00	36.00
		<b>2440</b>	<b>17.38</b>	<b>19.88</b>	<b>30.00</b>	<b>36.00</b>
		2480	16.96	19.46	30.00	36.00
	2	2402	11.88	14.38	30.00	36.00
		2440	12.40	14.90	30.00	36.00
		2480	11.91	14.41	30.00	36.00
	3	2402	12.06	14.56	30.00	36.00
		2440	12.62	15.12	30.00	36.00
		2480	12.30	14.80	30.00	36.00
FPA3020- 10A PCB/Flex Antenna	1	2402	16.35	20.58	30.00	36.00
		<b>2440</b>	<b>17.38</b>	<b>21.61</b>	<b>30.00</b>	<b>36.00</b>
		2480	16.96	21.19	30.00	36.00
	2	2402	11.88	16.11	30.00	36.00
		2440	12.40	16.63	30.00	36.00
		2480	11.91	16.14	30.00	36.00
	3	2402	12.06	16.29	30.00	36.00
		2440	12.62	16.85	30.00	36.00
		2480	12.30	16.53	30.00	36.00



**Test Plots:**

**Data Rate: 1Mbps**

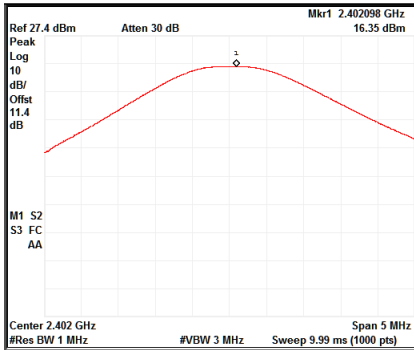

Channel Frequency:2402MHz

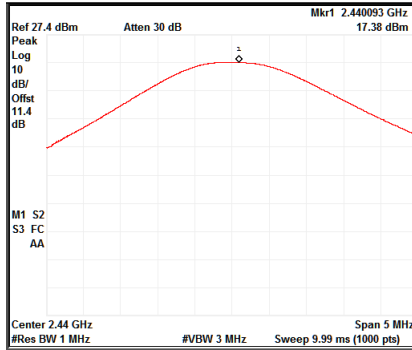

Channel Frequency:2440MHz

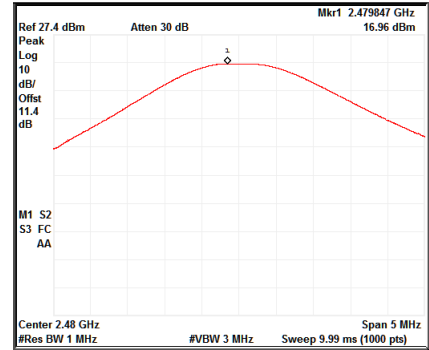

Channel Frequency:2480MHz

**Data Rate: 2Mbps**

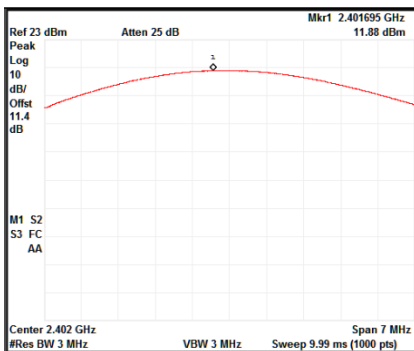

Channel Frequency:2402MHz

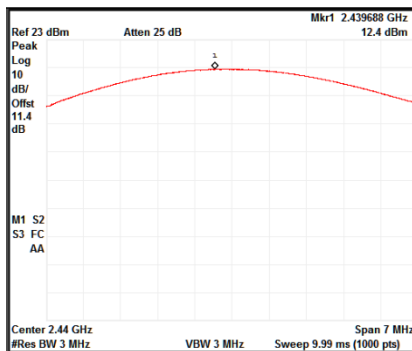

Channel Frequency:2440MHz

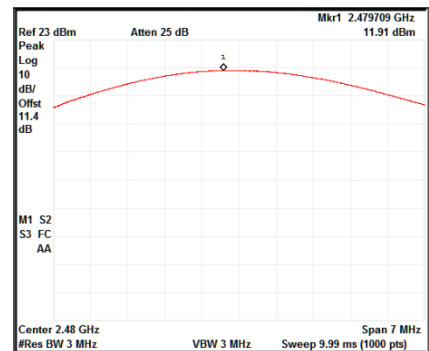

Channel Frequency:2480MHz

**Data Rate: 3Mbps**

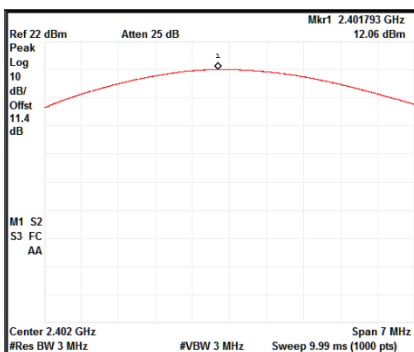

Channel Frequency:2402MHz

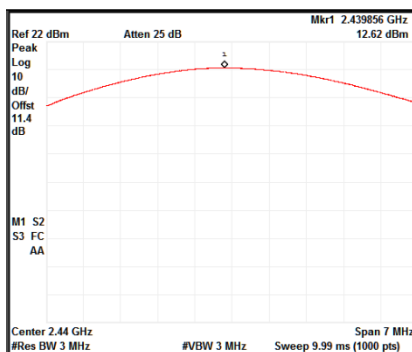

Channel Frequency:2440MHz

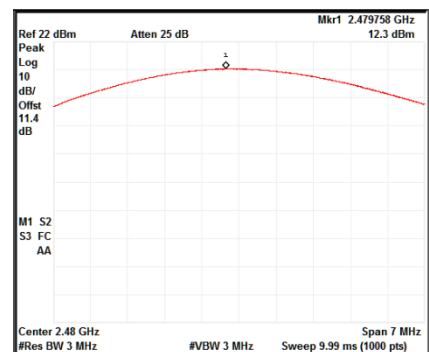

Channel Frequency:2480MHz

## 7.2 20dB Bandwidth & 99% Bandwidth

**Result**

**Pass**

Test Specification	FCC part 15 Subpart C 15.247 (a) (i) / RSS 247 Issue 2, Section 5.1 (b)
Test Method	Subclause 7.8.7 of ANSI C63.10
Measurement Bandwidth	30 kHz
Detector	Peak
Port of testing	Antenna port

Requirement

The bandwidth of frequency hopping channel is the 20 dB emission bandwidth ,measured with the hopping stopped. The system RF bandwidth is equal to the channel bandwidth multiplied by the number of channels in the hopset. The hopset shall be such that the near-term distribution of frequencies appears random , with sequential hops randomly distributed in both direction and magnitude of change in the hopset while the long-term distribution appears evenly distributed.

**Test Method:**

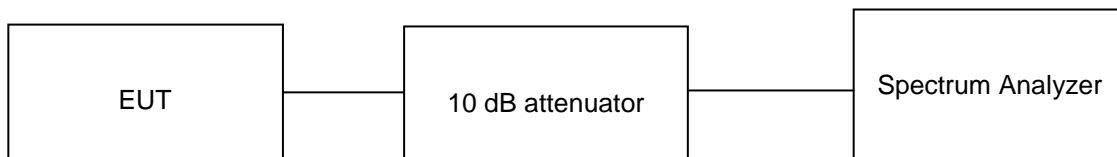

**Test Condition**

**Normal Test Condition:**

Temperature (Norm) = + 22.3°C      Voltage = 3.3 V DC through AC to Dc adaptor      Relative humidity: 62 %

**KDB Guidelines applied:**

Measurements were made as per section 9(b) in KDB 558074 D01 15.247 Measurement Guidance v05r02.

**Test results:**

1. All the losses are included during measurement and final values are mentioned in the test report.

Data Rate (Mbps)	Channel Frequency (MHz)	20 dB Bandwidth (MHz)	99% OBW (MHz)
1	2402	0.930	0.910
	2440	0.933	0.910
	2480	0.930	0.910
2	2402	1.20	1.33
	2440	1.20	1.32
	2480	1.21	1.33
3	2402	1.20	1.30
	2440	1.21	1.30
	2480	1.22	1.31

**Data Rate: 1Mbps**

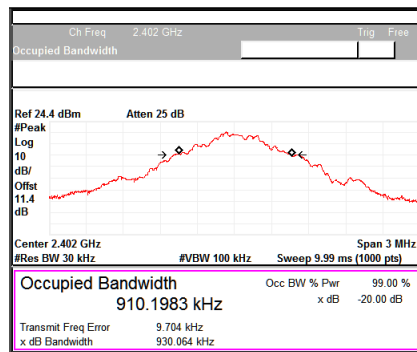

Channel Frequency:2402MHz

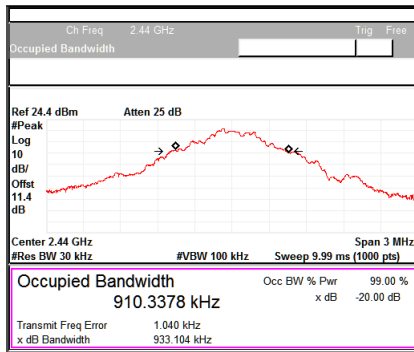

Channel Frequency:2440MHz

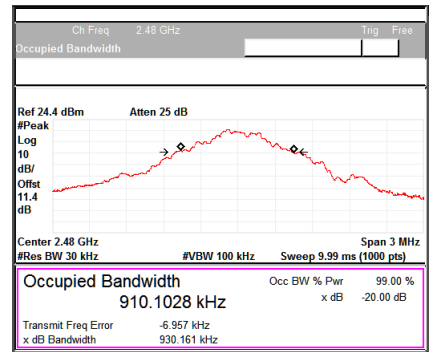

Channel Frequency:2480MHz

**Data Rate: 2Mbps**

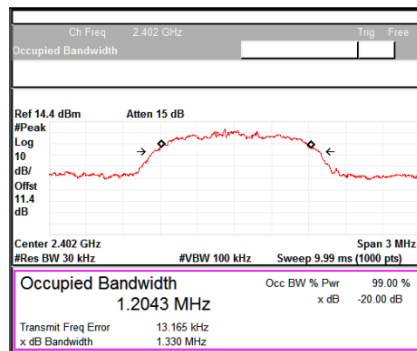

Channel Frequency:2402MHz

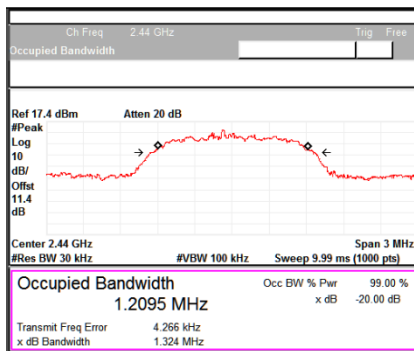

Channel Frequency:2440MHz

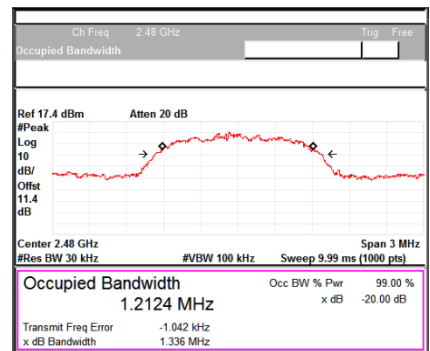

Channel Frequency:2480MHz

**Data Rate: 3Mbps**

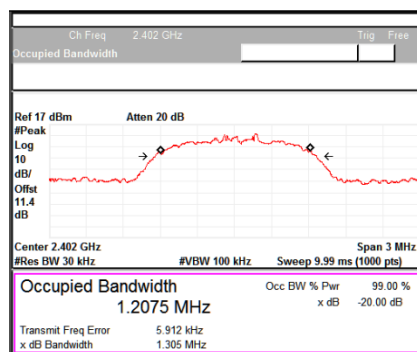

Channel Frequency:2402MHz

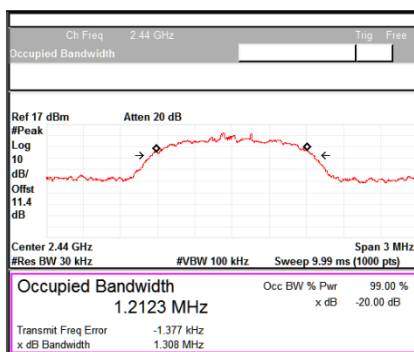

Channel Frequency:2440MHz

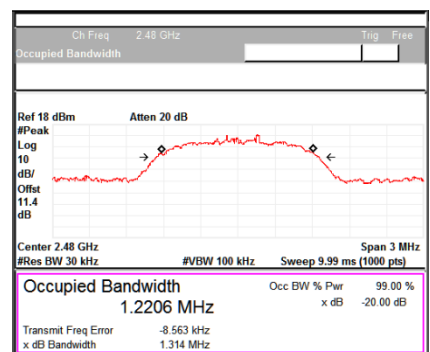

Channel Frequency:2480MHz

**Prüfbericht - Nr.:**  
Test Report No.:

**IN23ZC8W 001**

Seite 20 von 50  
Page 20 of 50

### 7.3 Number of Hopping Channels

**Result**

**Pass**

Test Specification	FCC Part 15 Subpart C Section 15.247 (a) (i) / RSS 247 Issue 2, Section 5.1 (d)
Test Method	Subclause 7.8.3 of ANSI C63.10
Measurement Bandwidth	100 kHz
Detector	Peak
Port of testing	Antenna port
Requirement	Frequency hopping systems operating in the band 2400-2483.5 MHz shall use at least 15 hopping channels

**Test Method:**

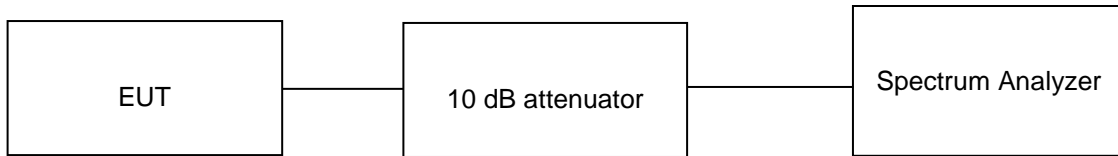

**Test Condition**

**Normal Test Condition:**

Temperature (Norm) = + 25 °C      Voltage = 3.3 V DC through AC to Dc adaptor      Relative humidity: 62 %

**KDB Guidelines applied:**

Measurements were made as per section 9(b) in KDB 558074 D01 15.247 Measurement Guidance v05r02.

**Test results:**

**Note:**

- All the losses are included during measurement and final values are mentioned in the test report.

**Test Plots:**

**Data Rate: 1Mbps**

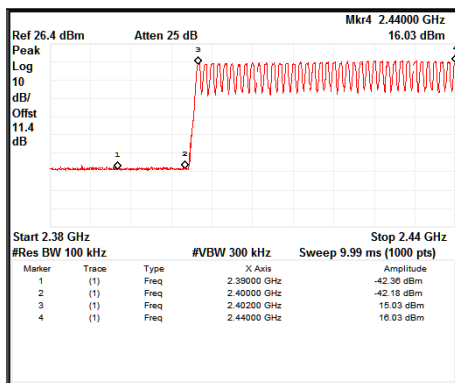

Frequency range: 2380MHz to 2440MHz

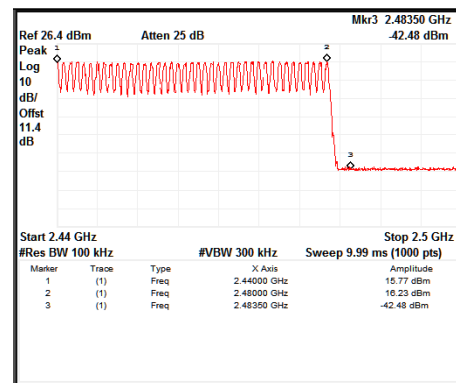

Frequency range: 2440MHz to 2500MHz

**Data Rate: 2Mbps**

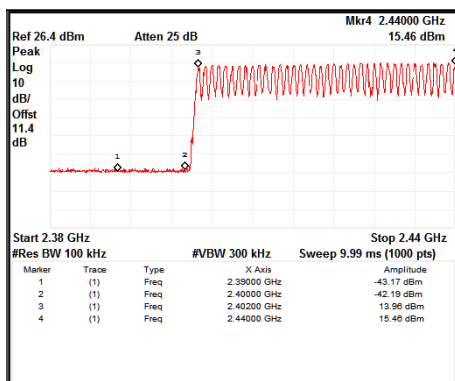

Frequency range: 2380MHz to 2440MHz

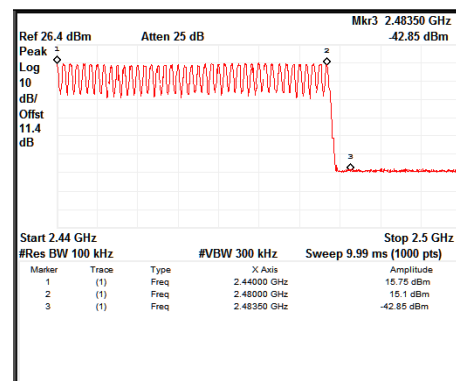

Frequency range: 2440MHz to 2500MHz

**Data Rate: 3Mbps**

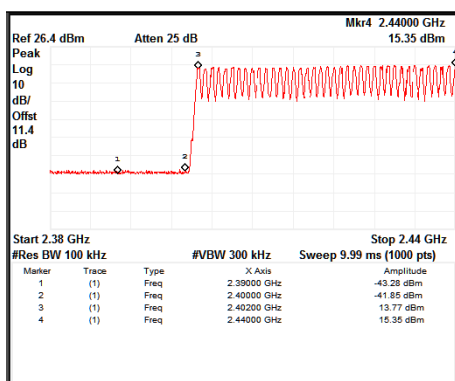

Frequency range: 2380MHz to 2440MHz

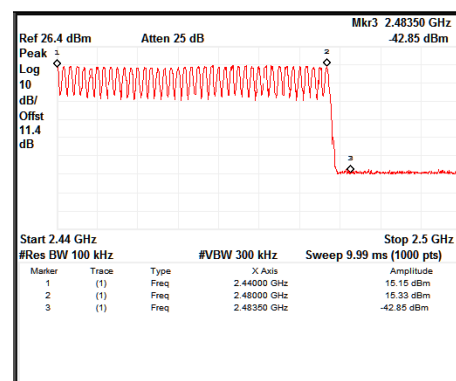

Frequency range: 2440MHz to 2500MHz

Number of Hopping frequencies for all data rates = 79

**Prüfbericht - Nr.:**  
Test Report No.:

**IN23ZC8W 001**

Seite 22 von 50  
Page 22 of 50

## 7.4 Carrier Frequency Separation

### Result

### Pass

Test Specification	FCC Part 15 Subpart C Section 15.247 (a) (1) / RSS 247 Issue 2, Section 5.1 (b)
Test Method	Clause 7.8.2 of ANSI C63.10
Measurement Bandwidth	300 kHz
Detector	Peak
Port of testing	Antenna port
Requirement	Frequency hopping systems shall have hopping channel carrier frequency separated by a minimum of 25kHz or the 20dB bandwidth of the hopping channel, whichever is greater

#### Test Method:

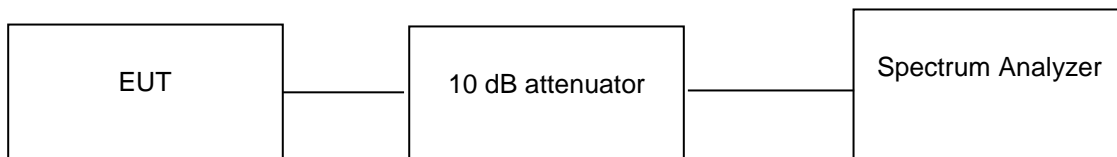

#### Test Condition

##### Normal Test Condition:

Temperature (Norm) = + 25 °C      Voltage = 3.3 V DC through AC to Dc adaptor      Relative humidity: 62%

#### KDB Guidelines applied:

Measurements were made as per section 9(b) in KDB 558074 D01 15.247 Measurement Guidance v05r02.

**Test results:**

**Note:**

- All the losses are included during measurement and final values are mentioned in the test report.

Data rate (Mbps)	Channel Frequency (MHz)	Channel spacing Observed (MHz)	20 dB Bandwidth (MHz)
1	2439	1	0.930
	2440	1	0.933
	2441	1	0.930
2	2439	1	1.33
	2440	1	1.32
	2441	1	1.33
3	2439	1	1.30
	2440	1	1.30
	2441	1	1.31

**Test Plots:**

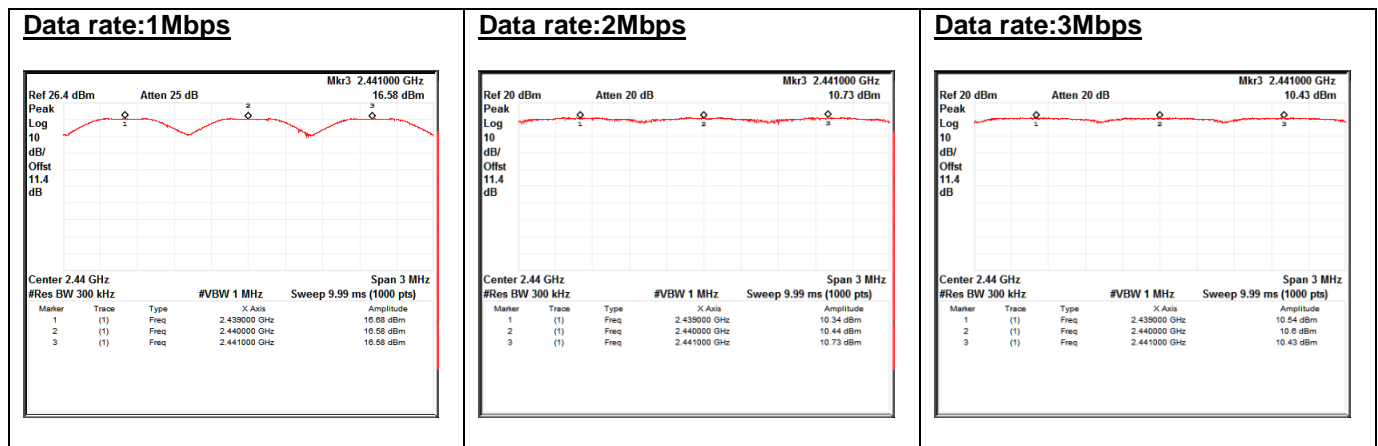

**Prüfbericht - Nr.:**  
Test Report No.:

**IN23ZC8W 001**

Seite 24 von 50  
Page 24 of 50

## 7.5 Time Of Occupancy(Dwell Time)

**Result**

**Pass**

Test Specification                      FCC Part 15 Subpart C Section 15.247 (a) (i) / RSS 247  
Issue 2,Section 5.1 (d)

Test Method                                Clause 7.8.4 of ANSI C63.10

Measurement Bandwidth                100 kHz

Detector                                    Peak

Port of testing                             Antenna port

Requirement                              The average time of occupancy on any channel shall not be greater than 0.4 seconds within a period of 0.4 seconds multiplied by the number of hopping channels employed. Transmissions on particular hopping frequencies may be avoided or suppressed provided that a minimum of 15 hopping channels are used.

### Test Method:

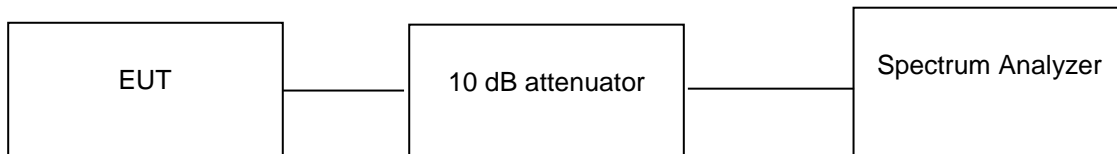

### Test Condition

#### Normal Test Condition:

Temperature (Norm) = + 25 °C              Voltage = 3.3 V DC through AC to Dc adaptor              Relative humidity: 62%

### KDB Guidelines applied:

Measurements were made as per section 9(b) in KDB 558074 D01 15.247 Measurement Guidance v05r02



**Test results:**

**Note:**

1. All the losses are included during measurement and final values are mentioned in the test report
2. Testing is performed for all the applicable data rates only worst case graphs are reported (3DH5)

**Data Rate: 3DH5**

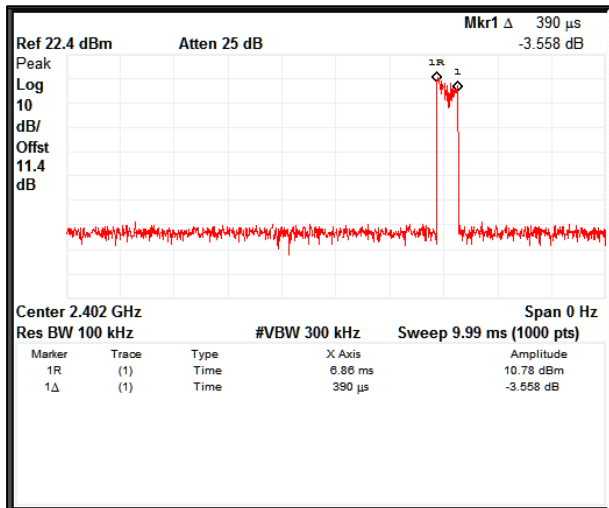

**Dwell time**

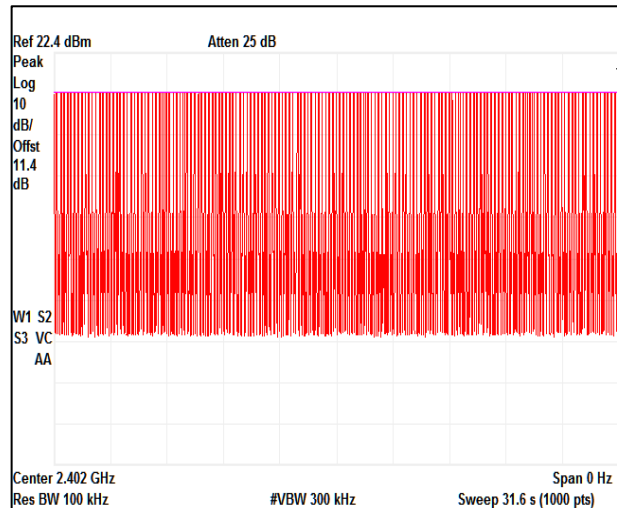

**No. of Bin Calculation**

Single Burst	390	µs
Measured Span (Seconds)	31.6	sec
No. Of Bins/Bursts in Measured Span	166	No.
Observation Period (79 hop ch x0.4s) - Seconds	31.6	sec
<b>Total Burst in 31.6sec</b>	<b>64.74</b>	<b>ms</b>
Limit	400.00	ms

## 7.6 Emissions in non-restricted frequency bands and Conducted Spurious Emission

**Result**

**Pass**

Test Specification: FCC part 15 Subpart C 15.247 (d) / RSS 247 Issue 2, Section 5.5

Test Method: Subclause 11.11 of ANSI C63.10

Measurement Bandwidth: 100 kHz

Detector: Peak

Port of testing: Antenna port

Requirement: In any 100kHz bandwidth outside the frequency band in which the spread spectrum or digitally modulated intentional radiator is operating, the radio frequency power that is produced by the intentional radiator shall be at least 30dB below that in the 100kHz bandwidth within the band that contains the highest level of the desired power, based on either an RF conducted or a radiated measurement, provided the transmitter demonstrates compliance with the peak conducted power limits

If the transmitter complies with the conducted power limits based on the use of RMS averaging over a time interval, the attenuation required under this paragraph shall be 30 dB instead of 20 dB

**Test Method:**

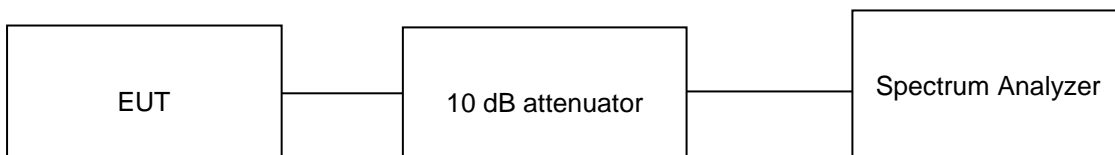

**Test Condition**

**Normal Test Condition:**

Temperature (Norm) = +25 °C      Voltage = 3.3 V DC through AC to Dc adaptor      Relative humidity: 62 %

**KDB Guidelines applied:**

Measurements were made as per section 8.5 in KDB 558074 D01 15.247 Measurement Guidance v05r02.

**Test results:**

**Note:**

1. All the losses are included during measurement and final values are mentioned in the test report.
2. Final Value (dBm) = Measured Value (dBm) + Attenuator factor (10dB) + Cable loss (0.5dB)
3. This product do not support additional beamforming gain / directional gain, it uses signal antenna and hence directional gain of the single antenna is 2.35 dBi

**7.6.1 Reference plots**

**Data Rate: 1Mbps**

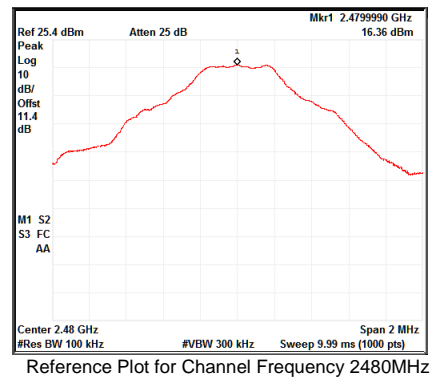
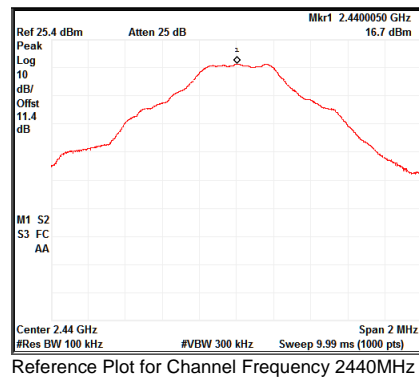
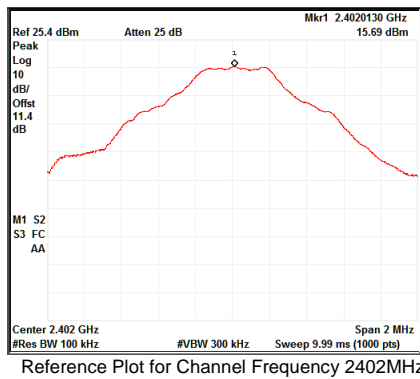

**Data Rate: 2Mbps**

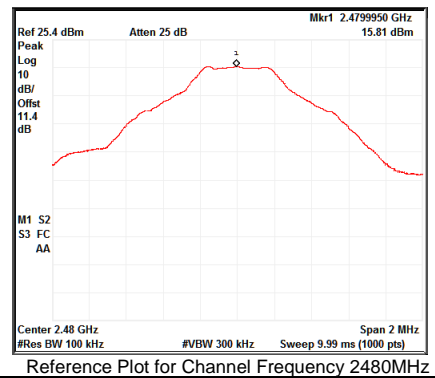
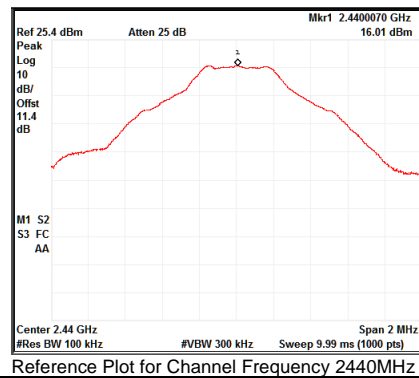
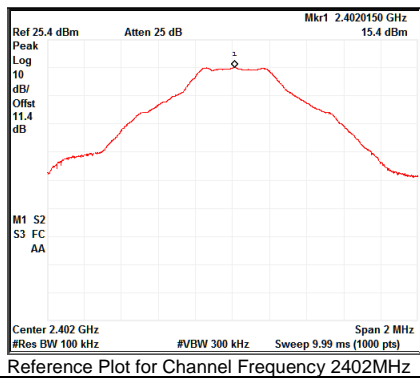

**Data Rate: 3Mbps**

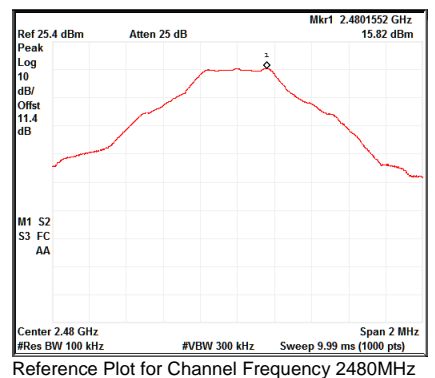
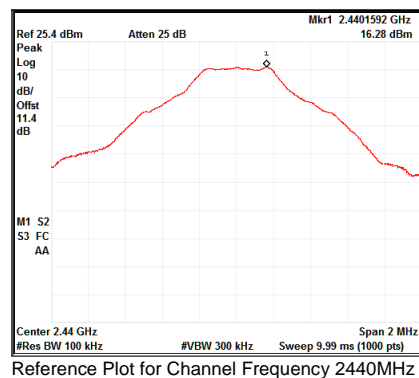
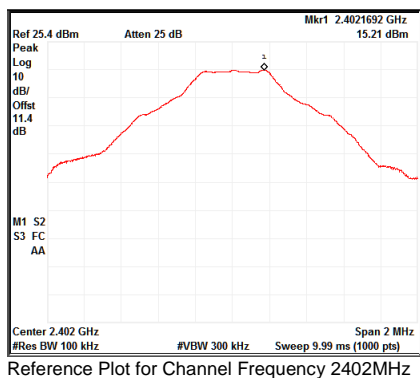

7.6.2 Band Edge

Data rate	Channel Frequency (MHz)	Band edge frequency (MHz)	Value at band edge (A) (dBm)	Reference value (B) (dBm)	A-B (dBc)	Minimum Limit (dBc)
1Mbps	2402.00	2400.00	-41.71	15.69	-57.40	-20
	2480.00	2483.50	-42.35	16.36	-58.71	-20
2Mbps	2402.00	2400.00	-47.20	9.88	-57.08	-20
	2480.00	2483.50	-49.32	10.26	-59.58	-20
3Mbps	2402.00	2400.00	-45.48	9.80	-55.28	-20
	2480.00	2483.50	-47.74	10.24	-57.98	-20

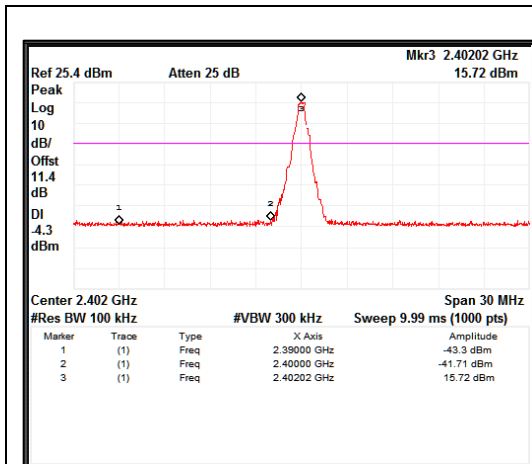

Data rate: 1Mbps Channel Frequency 2402MHz

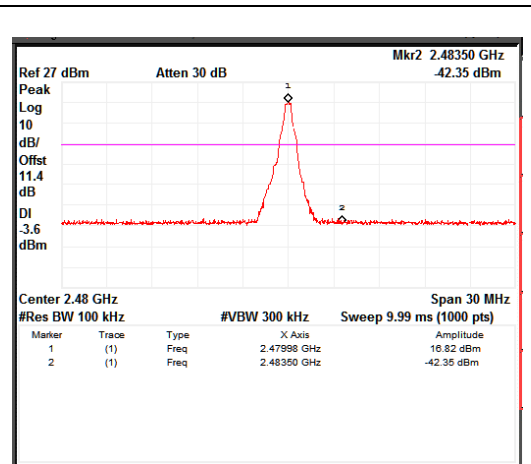

Data rate: 1Mbps Channel Frequency 2480MHz

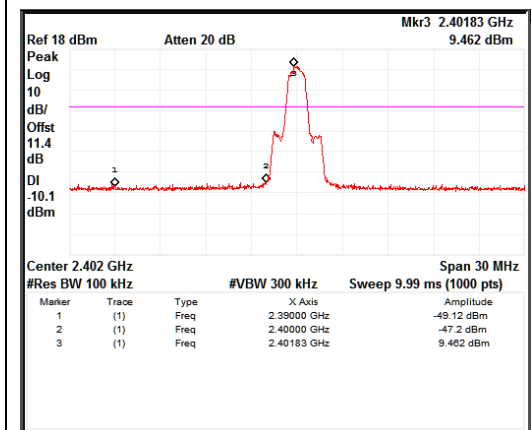

Data rate: 2Mbps Channel Frequency 2402MHz

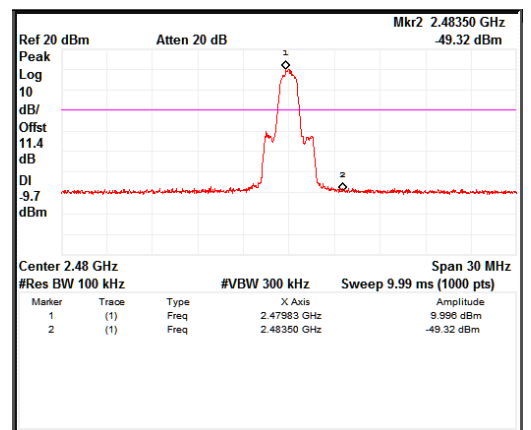

Data rate: 2Mbps Channel Frequency 2480MHz

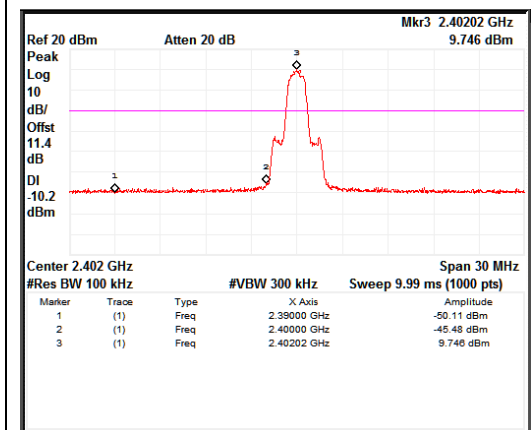

Data rate: 3Mbps Channel Frequency 2402MHz

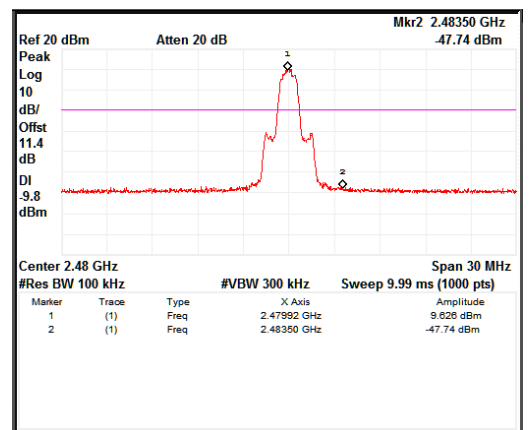

Data rate: 3Mbps Channel Frequency 2480MHz

7.6.3 Out-Of-Band Emissions

Data Rate: 1Mbps

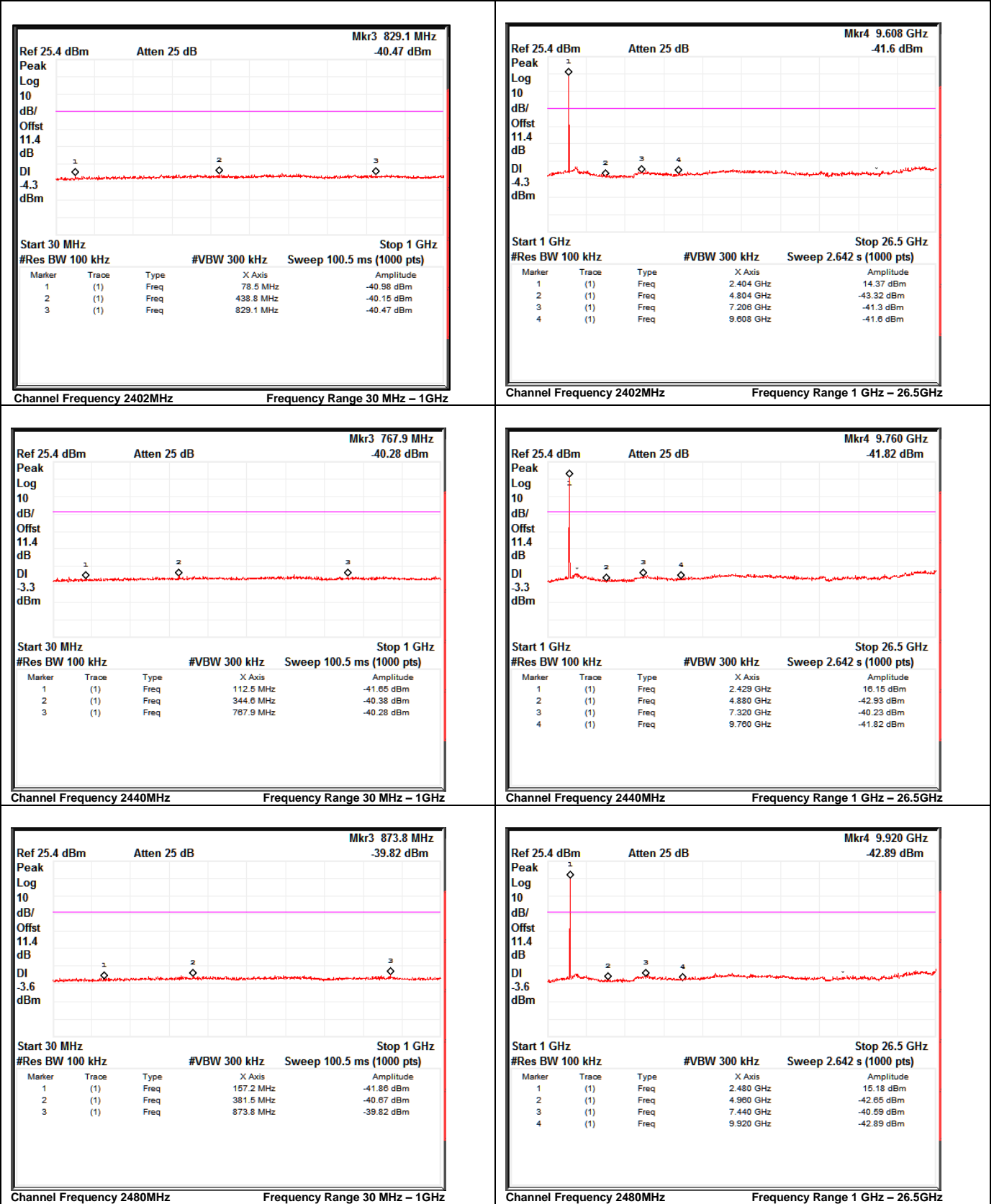

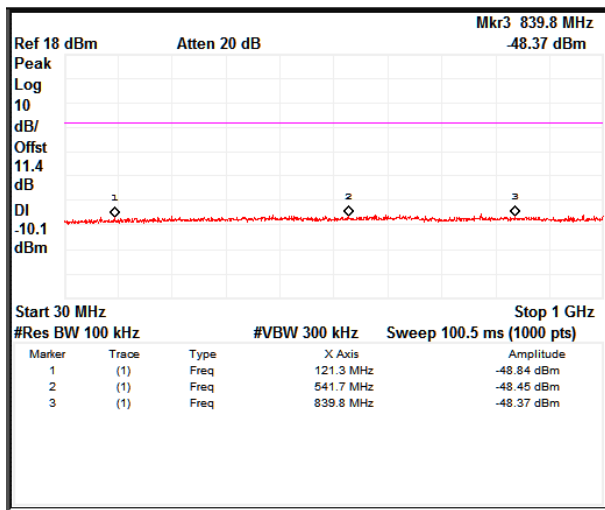
**Data Rate: 2Mbps**

Channel Frequency 2402MHz

Frequency Range 30 MHz - 1GHz

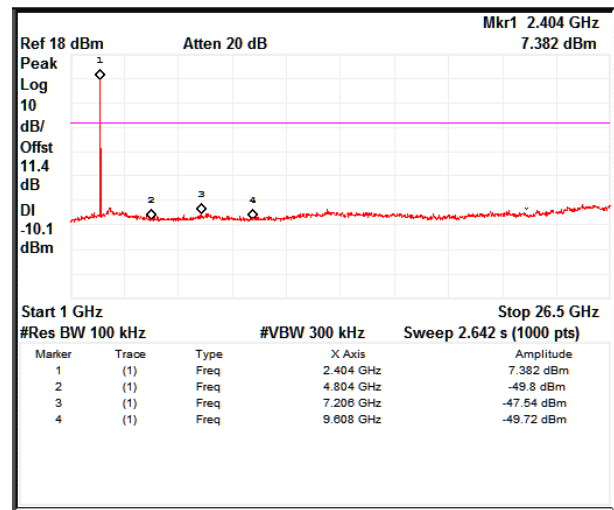

Channel Frequency 2402MHz

Frequency Range 1 GHz - 26.5GHz

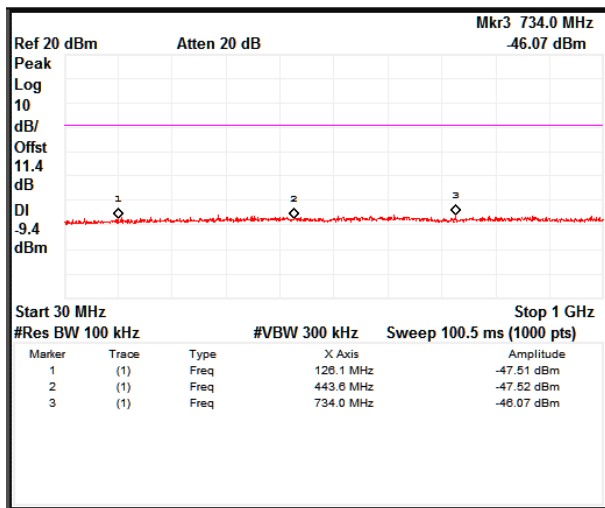

Channel Frequency 2440MHz

Frequency Range 30 MHz - 1GHz

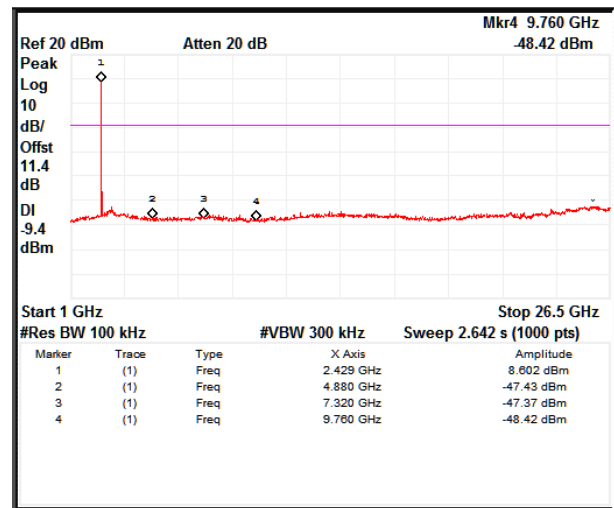

Channel Frequency 2440MHz

Frequency Range 1 GHz - 26.5GHz

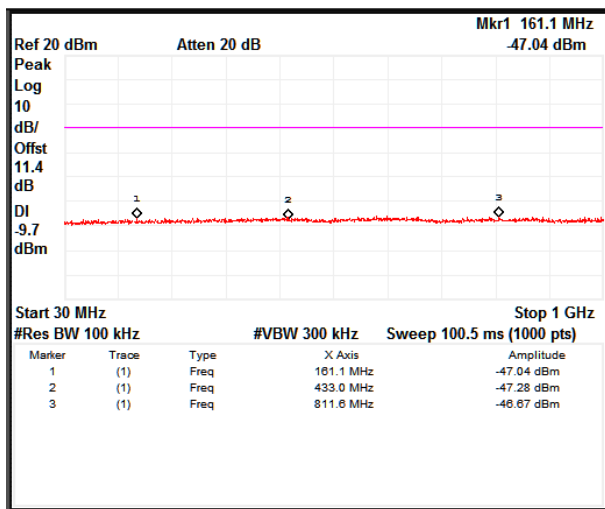

Channel Frequency 2480MHz

Frequency Range 30 MHz - 1GHz

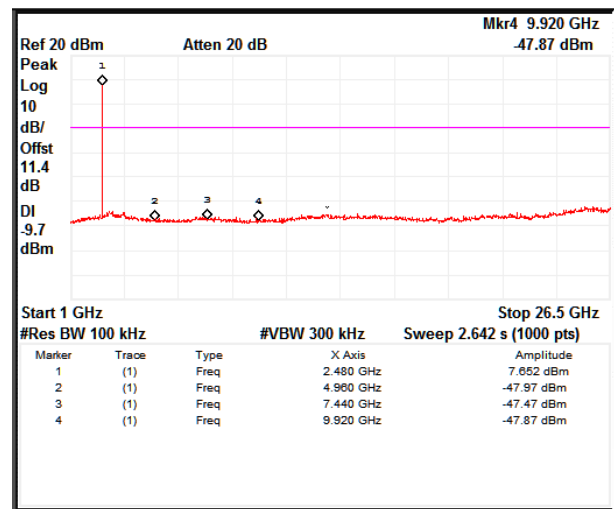

Channel Frequency 2480MHz

Frequency Range 1 GHz - 26.5GHz

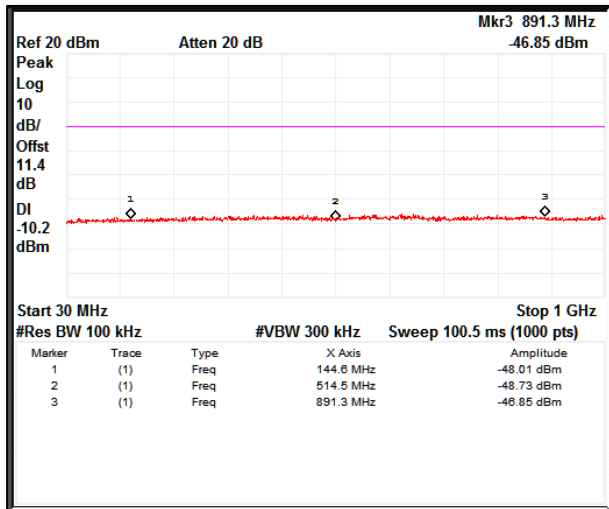
**Data Rate: 3Mbps**

Channel Frequency 2402MHz Frequency Range 30 MHz - 1GHz

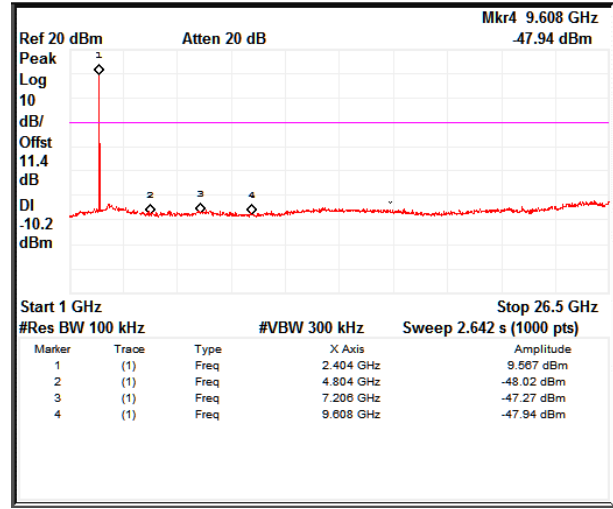

Channel Frequency 2402MHz Frequency Range 1 GHz - 26.5GHz

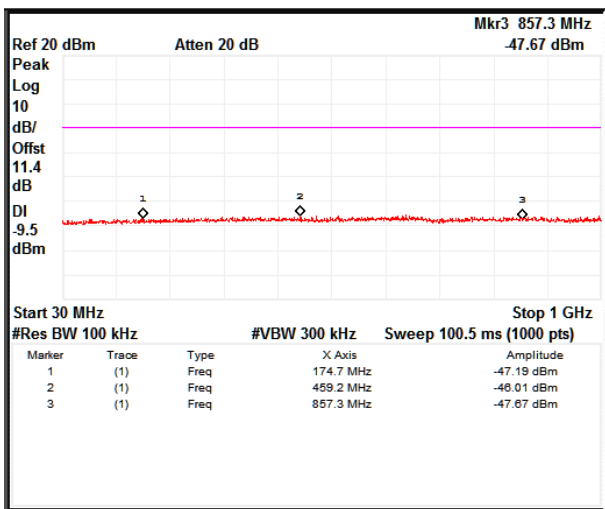

Channel Frequency 2440MHz Frequency Range 30 MHz - 1GHz

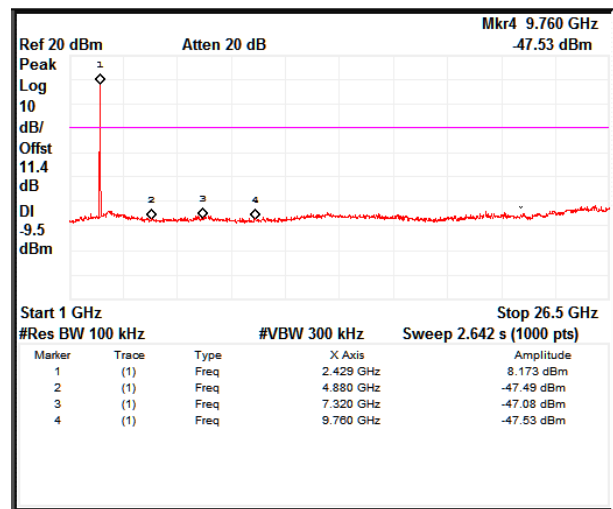

Channel Frequency 2440MHz Frequency Range 1 GHz - 26.5GHz

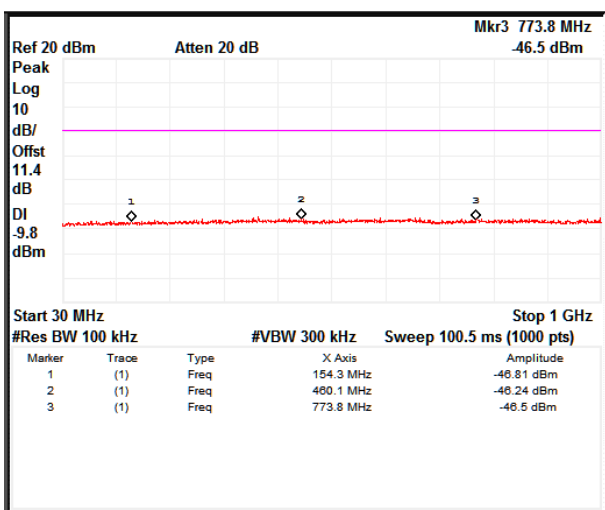

Channel Frequency 2480MHz Frequency Range 30 MHz - 1GHz

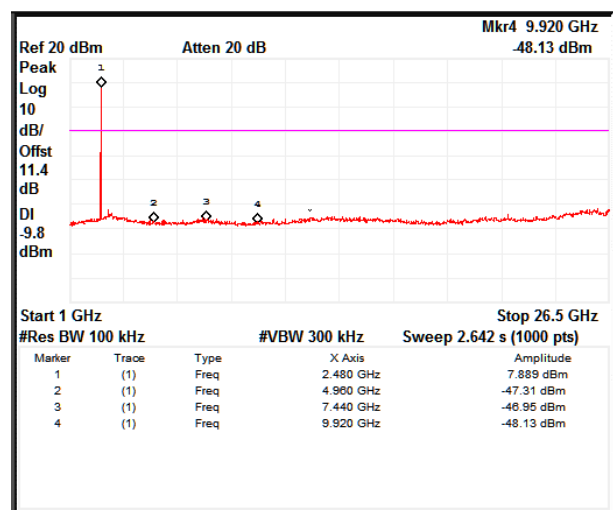

Channel Frequency 2480MHz Frequency Range 1 GHz - 26.5GHz

## 7.7 Spurious Radiated Emissions & Restricted Bands of Operation

<b>Result</b>	<b>Pass</b>
Test Specification	FCC part 15 Subpart C 15.247 (d) / (15.209 & 15.205) / IC RSS-GEN, Section 8.9 and 8.10
Test Method	ANSI C63.10
Measurement Location	Semi Anechoic Chamber 30MHz - 1 GHz Fully Anechoic Chamber 1 GHz - 40GHz
Measurement Bandwidth	100 kHz for frequency range < 1GHz 1 MHz for Frequency range >1GHz
Detector	Refer remarks below
Measuring Distance	3 m
Requirement	As per the limits mentioned in the below table
Test setup	Refer TEST METHODOLOGY

**Table 6: Transmitter limits for Radiated emission**

Frequency (MHz)	Field strength (μV/m)	Field strength (dBμV/m)	Distance of Measurement (m)
0.009 – 0.490	2400/F(kHz)	48.50 – 13.80	300*
0.490 – 1.705	24000/F(kHz)	33.80 – 23.00	30*
1.705 -30	30	29.54	30*
30-88	100	40.0	3
88-216	150	43.5	3
216-960	200	46.0	3
Above 960	500	54.0	3

Remark: \* The limit shows in the table above of frequency range 0.009 – 0.490, 0.490 – 1.705 MHz and 1.705-30MHz is at 300 meter, 30 meter and 30 meter range respectively, which corresponds to 128.51 – 93.80, 73.80 – 62.96 and 69.54 dBμV/m at 3m range by extrapolation calculation and the measurement of loop antenna.

The emission limits shown in the above table are based on measurements employing a CISPR quasi-peak detector except for the frequency bands 9–90 kHz, 110–490 kHz and above 1000 MHz Radiated emission limits in these three bands are based on measurements employing an average detector.

### Test Conditions:

Temperature (Norm) = + 21.6 °C      Voltage = 3.3 V DC through AC to Dc adaptor      Relative humidity = 62 %



**Prüfbericht - Nr.:**  
Test Report No.:

**IN23ZC8W 001**

Seite 33 von 50  
Page 33 of 50

**Test results:**

**Note:** All the losses are included during measurement and final values are mentioned in the test report. Refer TEST METHODOLOGY for more details

**Test results for frequency range 9kHz – 30MHz**

No emissions found in frequency range 9 kHz to 30 MHz, and measured levels are below 20dB from the limit line, hence not reported

**Test results for frequency range 30MHz – 1GHz**

Antenna Polarization	Measured Frequency (MHz)	Measured Value (dBµV/m)	Limit (dBµV/m)	Margin (dB)
Vertical	39.54	29.10	40.00	-10.90
	52.68	26.00	40.00	-14.00
	132.00	25.60	43.50	-17.90
	162.00	27.90	43.50	-15.60
	238.64	9.99	46.00	-36.01
	395.99	12.90	46.00	-33.10
	653.45	14.90	46.00	-31.10
Horizontal	39.63	16.20	40.00	-23.80
	57.06	16.60	43.50	-26.90
	127.95	27.00	43.50	-16.50
	157.98	33.93	43.50	-9.57
	263.99	3.93	46.00	-42.07
	395.99	18.70	46.00	-27.30
	659.84	14.20	46.00	-31.80

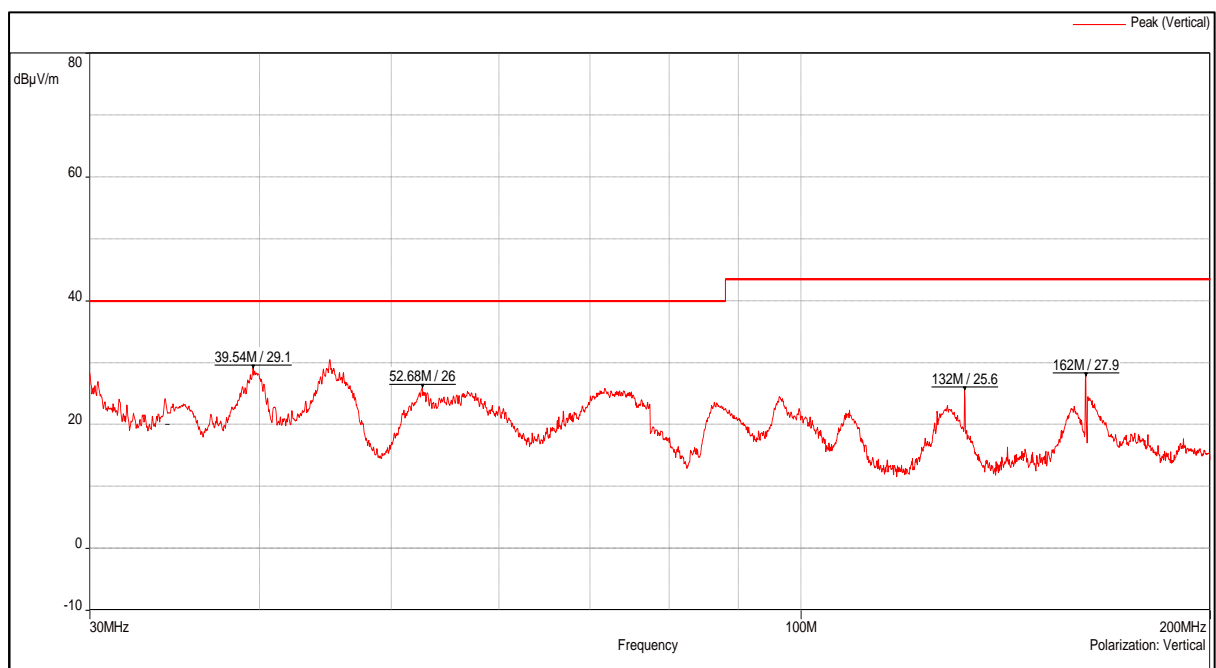

**Channel Frequency 30MHz – 200MHz**

**Polarization Vertical**

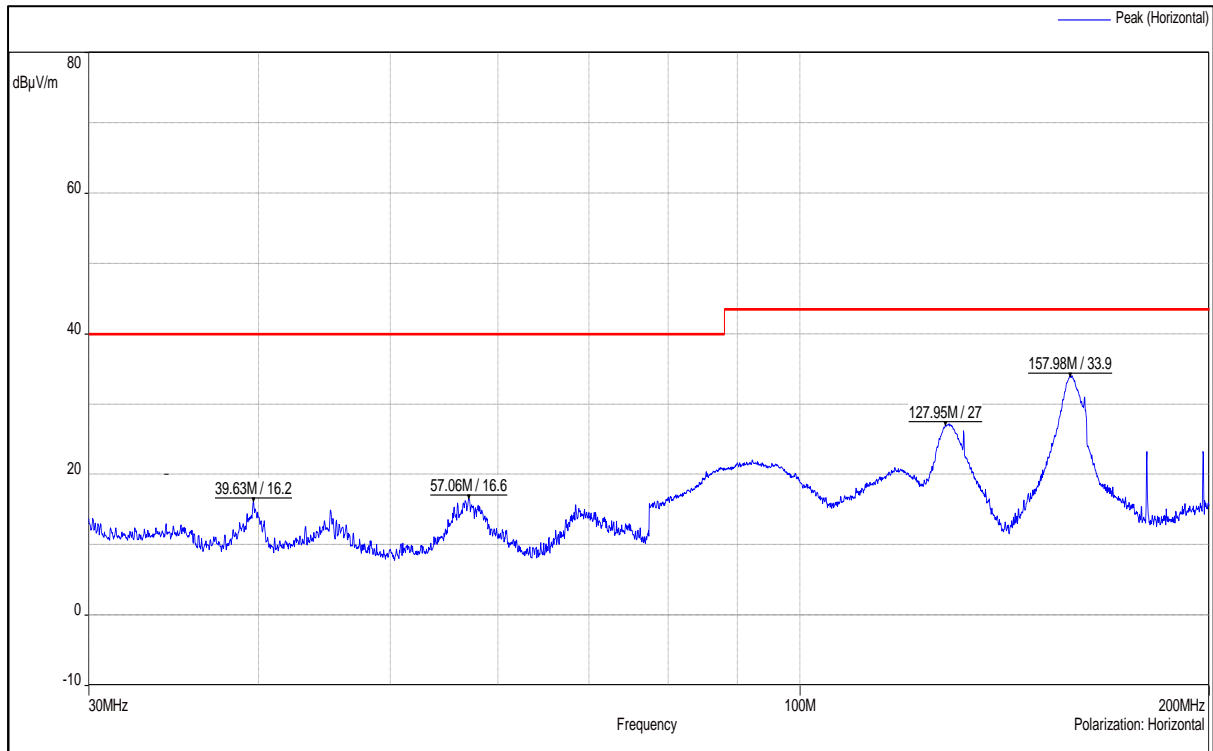

**Channel Frequency 30MHz – 200MHz**

**Polarization Horizontal**

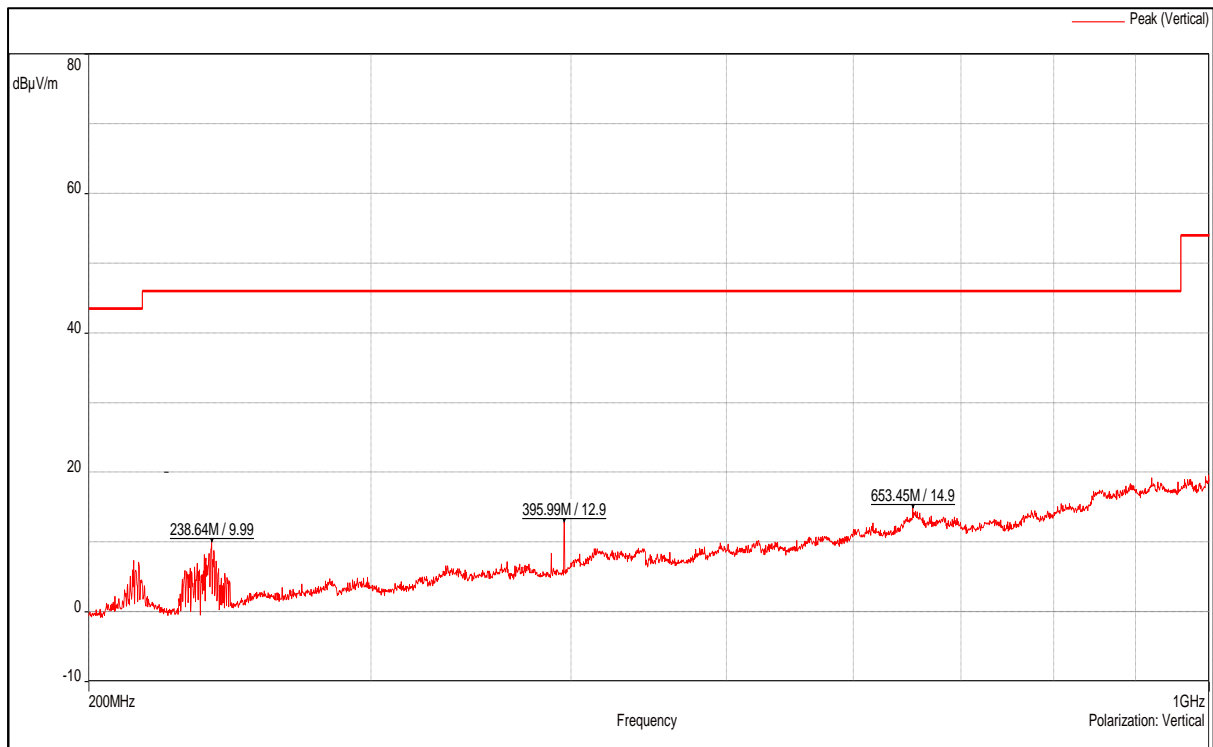

**Channel Frequency 200MHz – 1GHz**

**Polarization Vertical**

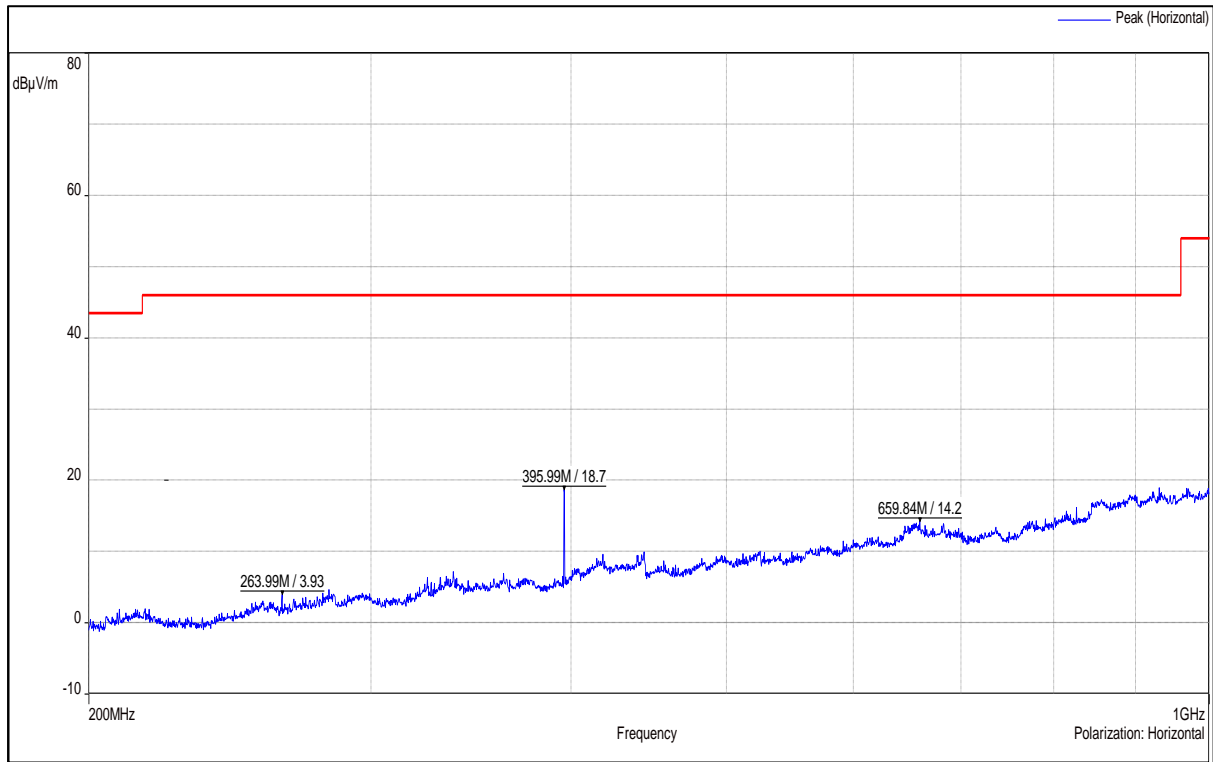

**Channel Frequency 200MHz – 1GHz**

**Polarization Horizontal**

**Prüfbericht - Nr.:**  
Test Report No.:

**IN23ZC8W 001**

Seite 36 von 50  
Page 36 of 50

**Test results for the frequencies above 1GHz**  
**Antenna Type: 1001932PT (PCB/Flex) Antenna Results**

Data rate (Mbps)	Channel Frequency (MHz)	Measured Frequency (MHz)	Antenna Polarization	Measured Emission (dBµV/m)	Limit (dBµV/m)	Margin (dB)
1	2402	2390(Pk)	Vertical	37.01	74.00*	-36.99
		2390(Av)		24.94	54.00*	-29.06
		2402(Pk)		100.83	-	-
		2402(Av)		87.99	-	-
		4804(Pk)		42.66	74.00	-31.34
		4804(Av)		29.51	54.00	-24.49
		7206(Pk)		46.89	74.00	-27.11
		7206(Av)		35.15	54.00	-18.85
		2390(Pk)	Horizontal	38.73	74.00*	-35.27
		2390(Av)		26.21	54.00*	-27.79
		2402(Pk)		105.30	-	-
		2402(Av)		92.47	-	-
		4804(Pk)		41.88	74.00	-32.12
		4804(Av)		29.78	54.00	-24.22
		7206(Pk)		46.59	74.00	-27.41
		7206(Av)		35.08	54.00	-18.92
	2440	Vertical	2440(Pk)	101.30	-	-
			2440(Av)	88.62	-	-
			4880(Pk)	41.44	74.00	-32.56
			4880(Av)	29.80	54.00	-24.20
			7320(Pk)	47.25	74.00	-26.75
		7320(Av)	35.13	54.00	-18.87	
		Horizontal	2440(Pk)	105.38	-	-
			2440(Av)	92.73	-	-
			4880(Pk)	44.34	74.00	-29.66
			4880(Av)	31.27	54.00	-22.73
	7320(Pk)		47.67	74.00	-26.33	
	7320(Av)	35.12	54.00	-18.88		
	2480	Vertical	2480(Pk)	101.67	-	-
			2480(Av)	89.72	-	-
			2483.5(Pk)	54.98	74.00*	-19.02
			2483.5(Av)	31.55	54.00*	-22.45
			4960(Pk)	42.53	74.00	-31.47
			4960(Av)	29.30	54.00	-24.70
			7440(Pk)	47.58	74.00	-26.42
			7440(Av)	35.34	54.00	-18.66
Horizontal		2480(Pk)	108.47	-	-	
		2480(Av)	96.52	-	-	
		2483.5(Pk)	61.51	74.00*	-12.49	
		2483.5(Av)	37.35	54.00*	-16.65	
		4960(Pk)	49.62	74.00	-24.38	
		4960(Av)	35.43	54.00	-18.57	
		7440(Pk)	48.13	74.00	-25.87	
		7440(Av)	35.62	54.00	-18.38	

\* : Indicate restricted band of operation §15.205  
- : Fundamental Frequency  
Pk: Peak Detector; Av: Average Detector

**Prüfbericht - Nr.:**  
Test Report No.:

**IN23ZC8W 001**

Seite 37 von 50  
Page 37 of 50

Data rate (Mbps)	Channel Frequency (MHz)	Measured Frequency (MHz)	Antenna Polarization	Measured Emission (dBµV/m)	Limit (dBµV/m)	Margin (dB)
2	2402	2390(Pk)	Vertical	36.63	74.00*	-37.37
		2390(Av)		25.02	54.00*	-28.98
		2402(Pk)		99.81	-	-
		2402(Av)		92.89	-	-
		4804(Pk)		41.27	74.00	-32.73
		4804(Av)		29.49	54.00	-24.51
		7206(Pk)		46.77	74.00	-27.23
		7206(Av)		35.10	54.00	-18.90
		2390(Pk)	Horizontal	38.48	74.00*	-35.52
		2390(Av)		26.32	54.00*	-27.68
		2402(Pk)		104.57	-	-
		2402(Av)		97.67	-	-
		4804(Pk)		42.21	74.00	-31.79
		4804(Av)		29.96	54.00	-24.04
		7206(Pk)		47.30	74.00	-26.70
		7206(Av)		35.11	54.00	-18.89
	2440	Vertical	2440(Pk)	103.08	-	-
			2440(Av)	96.43	-	-
			4880(Pk)	42.29	74.00	-31.71
			4880(Av)	29.52	54.00	-24.48
			7320(Pk)	47.55	74.00	-26.45
			7320(Av)	35.14	54.00	-18.86
		Horizontal	2440(Pk)	107.54	-	-
			2440(Av)	100.90	-	-
			4880(Pk)	44.41	74.00	-29.59
			4880(Av)	33.14	54.00	-20.86
			7320(Pk)	47.42	74.00	-26.58
			7320(Av)	35.17	54.00	-18.83
	2480	Vertical	2480(Pk)	100.83	-	-
			2480(Av)	94.64	-	-
			2483.5(Pk)	52.77	74.00*	-21.23
			2483.5(Av)	35.46	54.00*	-18.54
			4960(Pk)	42.02	74.00	-31.98
			4960(Av)	29.38	54.00	-24.62
			7440(Pk)	47.61	74.00	-26.39
			7440(Av)	35.52	54.00	-18.48
			Horizontal	2480(Pk)	107.39	-
		2480(Av)		101.20	-	-
		2483.5(Pk)		59.42	74.00*	-14.58
		2483.5(Av)		41.38	54.00*	-12.62
		4960(Pk)		48.29	74.00	-25.71
		4960(Av)		38.65	54.00	-15.35
		7440(Pk)		48.85	74.00	-25.15
		7440(Av)		36.05	54.00	-17.95

\* : Indicate restricted band of operation §15.205

- : Fundamental Frequency

Pk: Peak Detector; Av: Average Detector

**Prüfbericht - Nr.:**  
Test Report No.:

**IN23ZC8W 001**

Seite 38 von 50  
Page 38 of 50

Data Rate (Mbps)	Channel Frequency (MHz)	Measured Frequency (MHz)	Antenna Polarization	Measured Emission (dBµV/m)	Limit (dBµV/m)	Margin (dB)
3	2402	2390(Pk)	Vertical	37.50	74.00*	-36.50
		2390(Av)		24.99	54.00*	-29.01
		2402(Pk)		100.22	-	-
		2402(Av)		94.51	-	-
		4804(Pk)		41.44	74.00	-32.56
		4804(Av)		29.59	54.00	-24.41
		7206(Pk)		47.75	74.00	-26.25
		7206(Av)		35.29	54.00	-18.71
		2390(Pk)	Horizontal	39.80	74.00*	-34.20
		2390(Av)		26.38	54.00*	-27.62
		2402(Pk)		105.23	-	-
		2402(Av)		99.55	-	-
		4804(Pk)		41.85	74.00	-32.15
		4804(Av)		30.25	54.00	-23.75
		7206(Pk)		47.12	74.00	-26.88
		7206(Av)		35.20	54.00	-18.80
	2440(Pk)	Vertical	2440(Pk)	103.32	-	-
	2440(Av)		97.81	-	-	
	4880(Pk)		41.62	74.00	-32.38	
	4880(Av)		29.53	54.00	-24.47	
	7320(Pk)		47.48	74.00	-26.52	
	7320(Av)		35.12	54.00	-18.88	
	2440(Pk)	Horizontal	2440(Pk)	108.07	-	-
	2440(Av)		102.55	-	-	
	4880(Pk)		43.96	74.00	-30.04	
	4880(Av)		32.61	54.00	-21.39	
	7320(Pk)		47.29	74.00	-26.71	
	7320(Av)		35.15	54.00	-18.85	
	2480(Pk)	Vertical	2480(Pk)	100.87	-	-
	2480(Av)		95.84	-	-	
	2483.5(Pk)		54.43	74.00*	-19.57	
	2483.5(Av)		36.64	54.00*	-17.36	
	4960(Pk)		41.81	74.00	-32.19	
	4960(Av)		30.45	54.00	-23.55	
	7440(Pk)		48.09	74.00	-25.91	
	7440(Av)		36.13	54.00	-17.87	
2480(Pk)	Horizontal	2480(Pk)	107.36	-	-	
2480(Av)		102.35	-	-		
2483.5(Pk)		60.44	74.00*	-13.56		
2483.5(Av)		42.84	54.00*	-11.16		
4960(Pk)		47.90	74.00	-26.10		
4960(Av)		38.93	54.00	-15.07		
7440(Pk)		47.33	74.00	-26.67		
7440(Av)		35.55	54.00	-18.45		

\* : Indicate restricted band of operation §15.205  
- : Fundamental Frequency  
Pk: Peak Detector; Av: Average Detector

**Prüfbericht - Nr.:**  
Test Report No.:

**IN23ZC8W 001**

Seite 39 von 50  
Page 39 of 50

**Antenna Type: FPA3020-10A (PCB/Flex) Antenna Results**

Data Rate (Mbps)	Channel Frequency (MHz)	Measured Frequency (MHz)	Antenna Polarization	Measured Emission (dBµV/m)	Limit (dBµV/m)	Margin (dB)	
1	2402	2390(Pk)	Vertical	37.37	74.00*	-36.63	
		2390(Av)		24.95	54.00*	-29.05	
		2402(Pk)		103.15	-	-	
		2402(Av)		90.22	-	-	
		4804(Pk)		41.51	74.00	-32.49	
		4804(Av)		29.61	54.00	-24.39	
		7206(Pk)		48.22	74.00	-25.78	
		7206(Av)		35.28	54.00	-18.72	
		2390(Pk)		Horizontal	39.22	74.00*	-34.78
		2390(Av)	26.20		54.00*	-27.80	
		2402(Pk)	106.30		-	-	
		2402(Av)	93.36		-	-	
		4804(Pk)	41.93		74.00	-32.07	
		4804(Av)	29.68		54.00	-24.32	
		7206(Pk)	48.05		74.00	-25.95	
		7206(Av)	35.25		54.00	-18.75	
		2440	Vertical		2440(Pk)	106.28	-
				2440(Av)	93.81	-	-
	4880(Pk)			41.63	74.00	-32.37	
	4880(Av)			29.88	54.00	-24.12	
	7320(Pk)			46.94	74.00	-27.06	
	7320(Av)			35.39	54.00	-18.61	
	Horizontal		2440(Pk)	107.35	-	-	
			2440(Av)	94.85	-	-	
			4880(Pk)	45.01	74.00	-28.99	
			4880(Av)	32.39	54.00	-21.61	
			7320(Pk)	46.67	74.00	-27.33	
			7320(Av)	35.34	54.00	-18.66	
	2480	Vertical	2480(Pk)	104.41	-	-	
			2480(Av)	92.44	-	-	
			2483.5(Pk)	57.61	74.00*	-16.39	
			2483.5(Av)	33.39	54.00*	-20.61	
			4960(Pk)	43.24	74.00	-30.76	
			4960(Av)	30.28	54.00	-23.72	
			7440(Pk)	50.78	74.00	-23.22	
			7440(Av)	36.60	54.00	-17.40	
Horizontal		2480(Pk)	105.98	-	-		
		2480(Av)	94.02	-	-		
		2483.5(Pk)	59.01	74.00*	-14.99		
		2483.5(Av)	34.57	54.00*	-19.43		
		4960(Pk)	47.63	74.00	-26.37		
		4960(Av)	34.72	54.00	-19.28		
		7440(Pk)	47.04	74.00	-26.96		
		7440(Av)	35.47	54.00	-18.53		

\* : Indicate restricted band of operation §15.205  
 - : Fundamental Frequency  
 Pk: Peak Detector; Av: Average Detector

**Prüfbericht - Nr.:**  
Test Report No.:

**IN23ZC8W 001**

Seite 40 von 50  
Page 40 of 50

Data Rate (Mbps)	Channel Frequency (MHz)	Measured Frequency (MHz)	Antenna Polarization	Measured Emission (dBµV/m)	Limit (dBµV/m)	Margin (dB)	
2	2402	2390(Pk)	Vertical	37.69	74.00*	-36.31	
		2390(Av)		25.00	54.00*	-29.00	
		2402(Pk)		102.77	-	-	
		2402(Av)		95.82	-	-	
		4804(Pk)		42.09	74.00	-31.91	
		4804(Av)		29.72	54.00	-24.28	
		7206(Pk)		47.63	74.00	-26.37	
		7206(Av)		35.30	54.00	-18.70	
		2390(Pk)		Horizontal	38.21	74.00*	-35.79
		2390(Av)	26.34		54.00*	-27.66	
		2402(Pk)	105.77		-	-	
		2402(Av)	98.87		-	-	
		4804(Pk)	42.09		74.00	-31.91	
		4804(Av)	29.90		54.00	-24.10	
		7206(Pk)	47.22		74.00	-26.78	
		7206(Av)	35.30		54.00	-18.70	
		2440	Vertical		2440(Pk)	105.81	-
				2440(Av)	99.27	-	-
	4880(Pk)			42.56	74.00	-31.44	
	4880(Av)			30.15	54.00	-23.85	
	7320(Pk)			47.28	74.00	-26.72	
	7320(Av)			35.45	54.00	-18.55	
	Horizontal		2440(Pk)	107.72	-	-	
			2440(Av)	101.23	-	-	
			4880(Pk)	43.25	74.00	-30.75	
			4880(Av)	30.96	54.00	-23.04	
			7320(Pk)	47.28	74.00	-26.72	
			7320(Av)	35.34	54.00	-18.66	
	2480	Vertical	2480(Pk)	104.10	-	-	
			2480(Av)	98.07	-	-	
			2483.5(Pk)	56.82	74.00*	-17.18	
			2483.5(Av)	38.53	54.00*	-15.47	
			4960(Pk)	43.47	74.00	-30.53	
			4960(Av)	30.49	54.00	-23.51	
			7440(Pk)	49.62	74.00	-24.38	
			7440(Av)	38.38	54.00	-15.62	
Horizontal		2480(Pk)	105.61	-	-		
		2480(Av)	99.56	-	-		
		2483.5(Pk)	58.07	74.00*	-15.93		
		2483.5(Av)	39.76	54.00*	-14.24		
		4960(Pk)	42.76	74.00	-31.24		
		4960(Av)	30.28	54.00	-23.72		
7440(Pk)	47.10	74.00	-26.90				
7440(Av)	35.56	54.00	-18.44				

\* : Indicate restricted band of operation §15.205

- : Fundamental Frequency

Pk: Peak Detector; Av: Average Detector



Data Rate (Mbps)	Channel Frequency (MHz)	Measured Frequency (MHz)	Antenna Polarization	Measured Emission (dBµV/m)	Limit (dBµV/m)	Margin (dB)
3	2402	2390(Pk)	Vertical	37.63	74.00*	-36.37
		2390(Av)		25.05	54.00*	-28.95
		2402(Pk)		102.46	-	-
		2402(Av)		96.63	-	-
		4804(Pk)		41.67	74.00	-32.33
		4804(Av)		29.64	54.00	-24.36
		7206(Pk)		48.44	74.00	-25.56
		7206(Av)		35.25	54.00	-18.75
		2390(Pk)	Horizontal	39.13	74.00*	-34.87
		2390(Av)		26.36	54.00*	-27.64
		2402(Pk)		105.27	-	-
		2402(Av)		99.45	-	-
		4804(Pk)		41.41	74.00	-32.59
		4804(Av)		29.80	54.00	-24.20
		7206(Pk)		47.46	74.00	-26.54
		7206(Av)		35.27	54.00	-18.73
	2440(Pk)	Vertical	105.62	-	-	
	2440(Av)		100.22	-	-	
	4880(Pk)		42.64	74.00	-31.36	
	4880(Av)		30.06	54.00	-23.94	
	7320(Pk)		47.78	74.00	-26.22	
	7320(Av)		35.50	54.00	-18.50	
	2440(Pk)	Horizontal	107.46	-	-	
	2440(Av)		102.01	-	-	
	4880(Pk)		41.41	74.00	-32.59	
	4880(Av)		30.02	54.00	-23.98	
	7320(Pk)		47.00	74.00	-27.00	
	7320(Av)		35.29	54.00	-18.71	
	2480(Pk)	Vertical	103.88	-	-	
	2480(Av)		99.05	-	-	
	2483.5(Pk)		57.77	74.00*	-16.23	
	2483.5(Av)		40.40	54.00*	-13.60	
	4960(Pk)		41.95	74.00	-32.05	
	4960(Av)		30.46	54.00	-23.54	
	7440(Pk)		50.49	74.00	-23.51	
	7440(Av)		38.05	54.00	-15.95	
2480(Pk)	Horizontal		105.57	-	-	
2480(Av)			100.74	-	-	
2483.5(Pk)		59.25	74.00*	-14.75		
2483.5(Av)		41.96	54.00*	-12.04		
4960(Pk)		43.43	74.00	-30.57		
4960(Av)		31.99	54.00	-22.01		
7440(Pk)	Horizontal	47.08	74.00	-26.92		
7440(Av)		35.36	54.00	-18.64		

\* : Indicate restricted band of operation §15.205  
- : Fundamental Frequency  
Pk: Peak Detector; Av: Average Detector

**Worst Case Plots Reported**

Channel Frequency -2402MHz\_Veritical Polarization

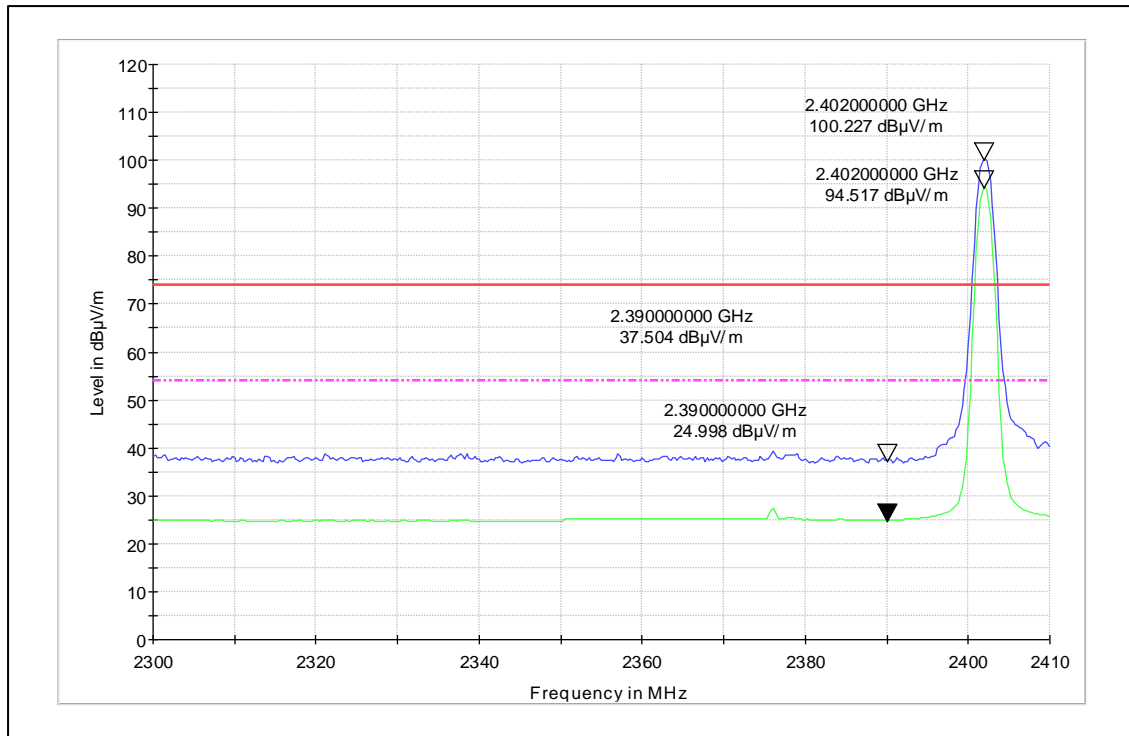

Channel Frequency -2440MHz\_Horizontal Polarization

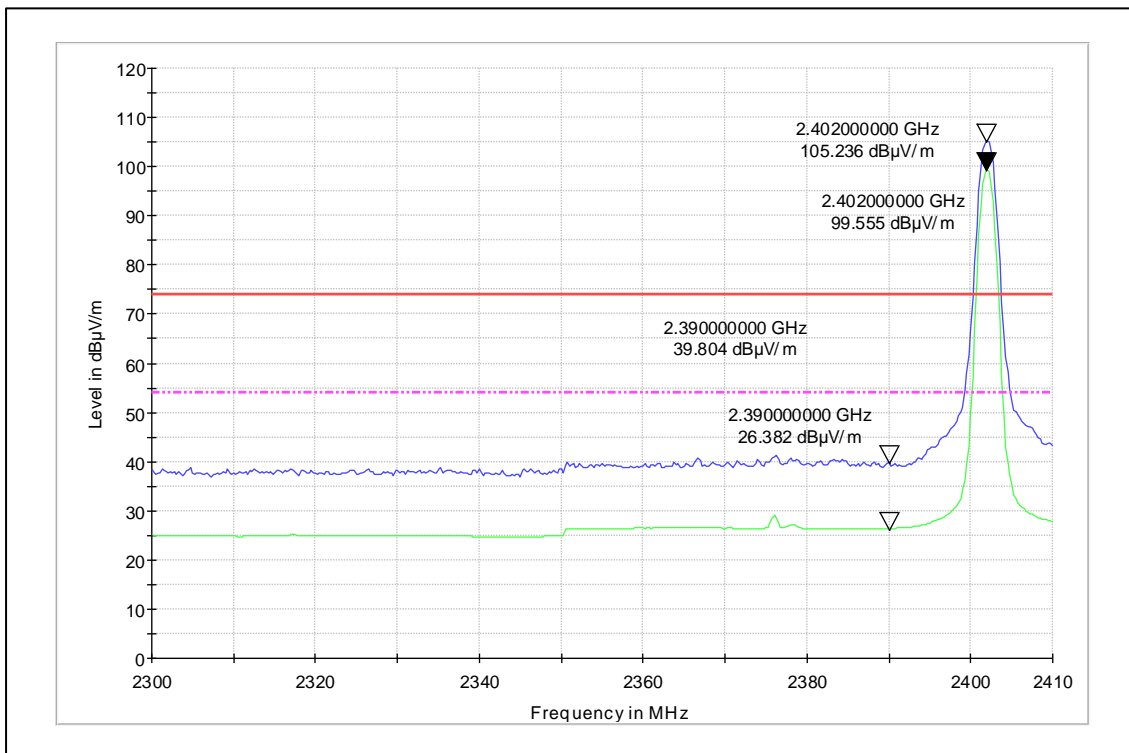

Channel Frequency -2440MHz\_Vertical Polarization

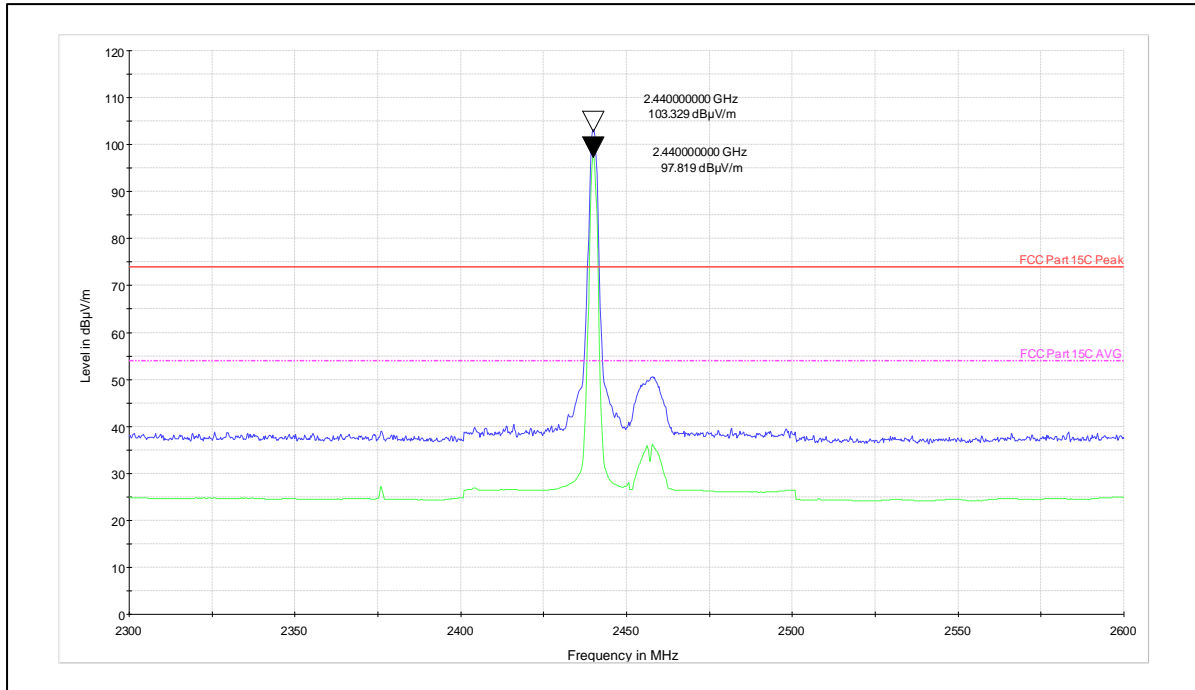

Channel Frequency -2440MHz\_Horizontal Polarization

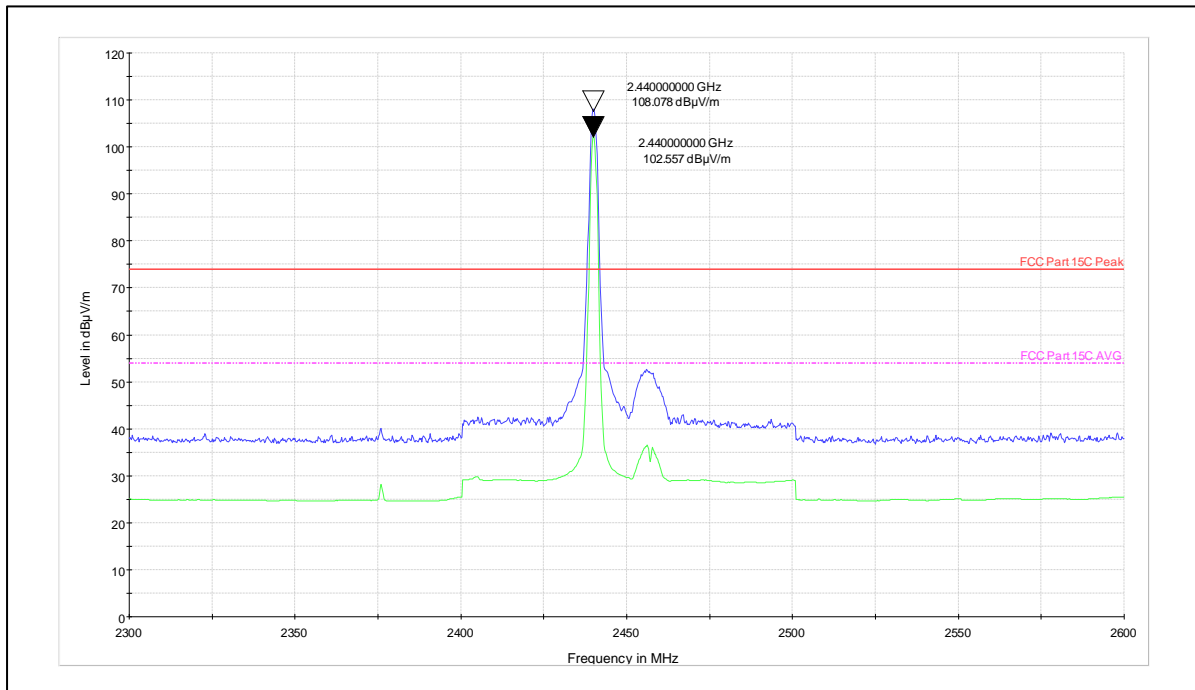

Channel Frequency -2480MHz\_Vertical Polarization

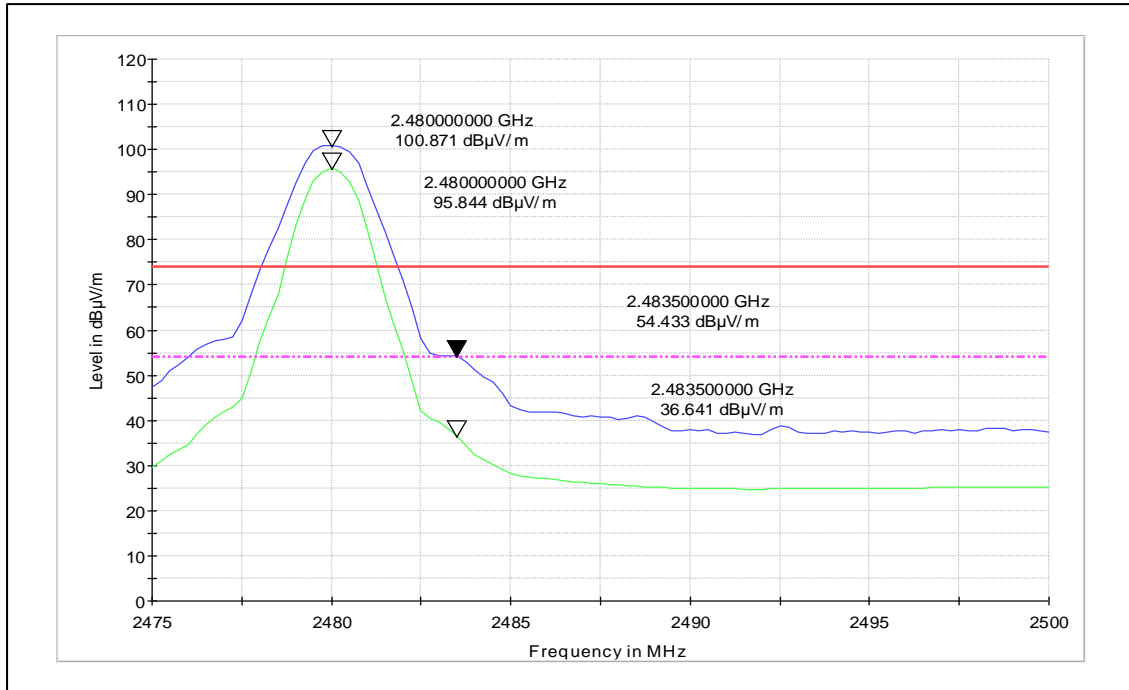

Channel Frequency -2480MHz\_Horizontal Polarization

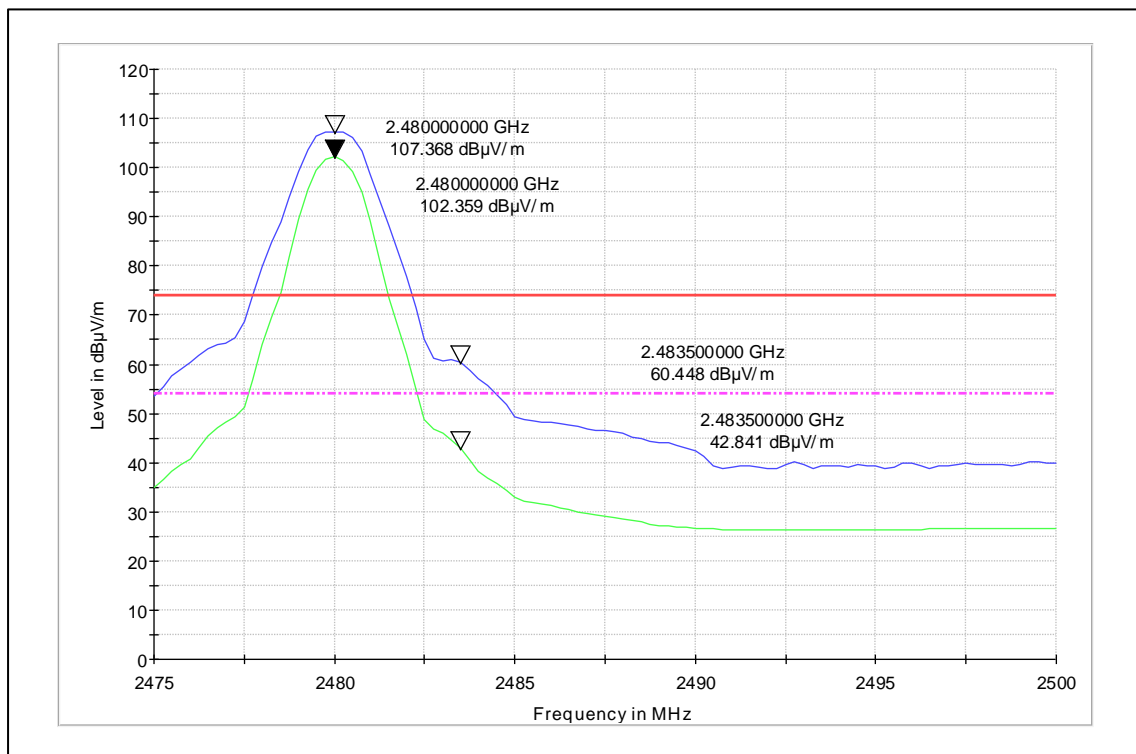

Channel Frequency -2440MHz\_Vertical Polarization \_1-18GHz

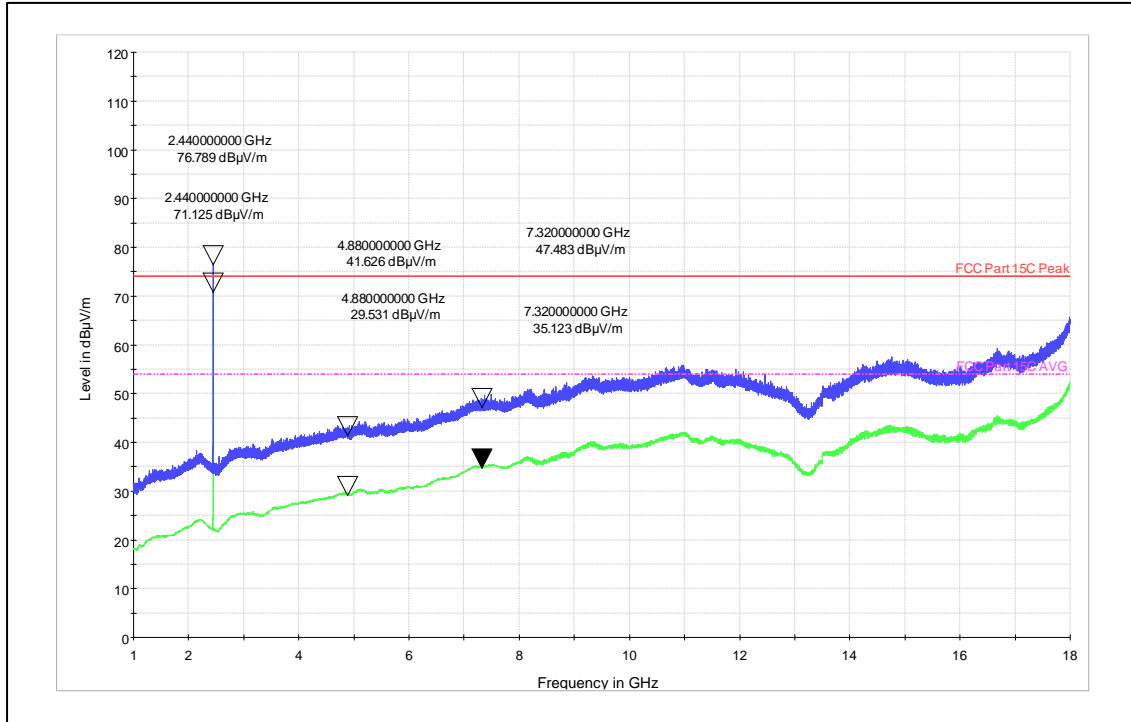

Channel Frequency-2440MHz\_Horizontal Polarization \_1-18GHz

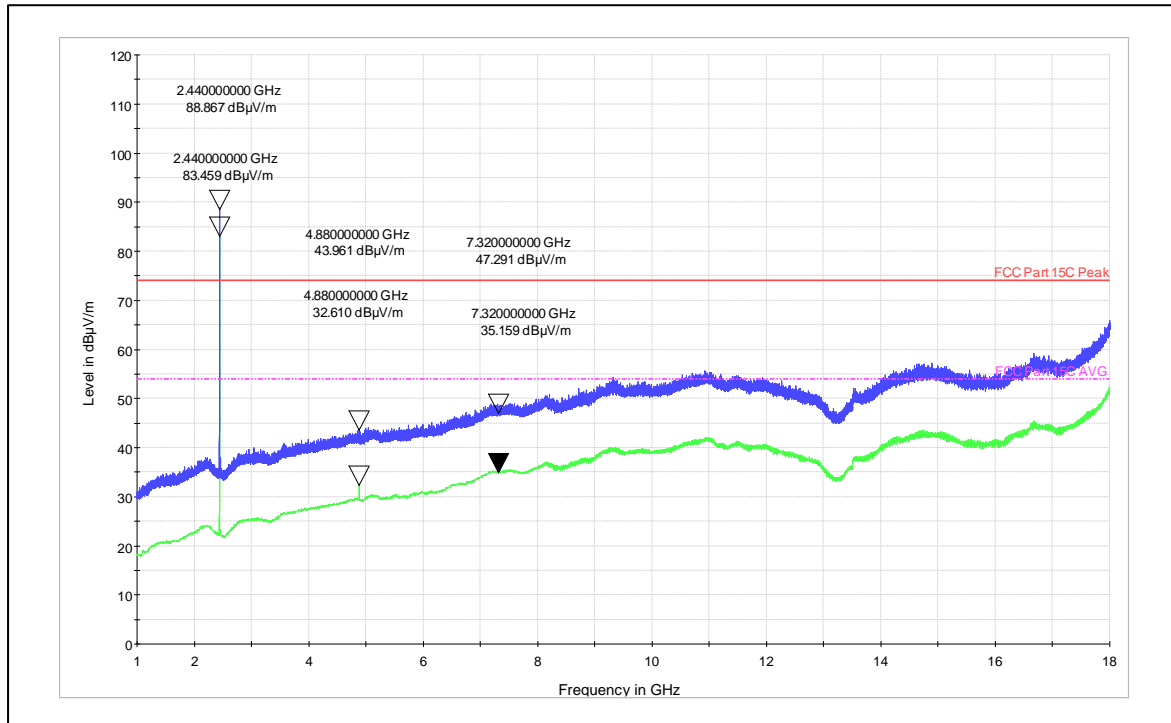

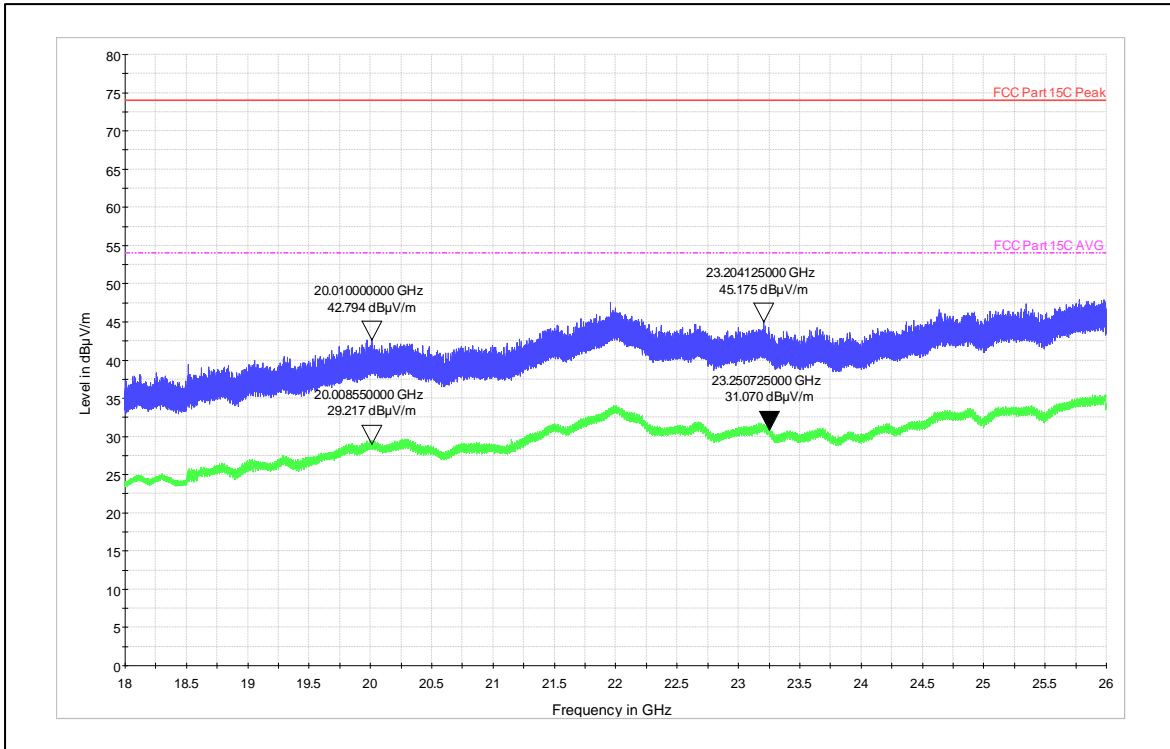

Frequency Range: 18 - 40 GHz

Polarization: Vertical

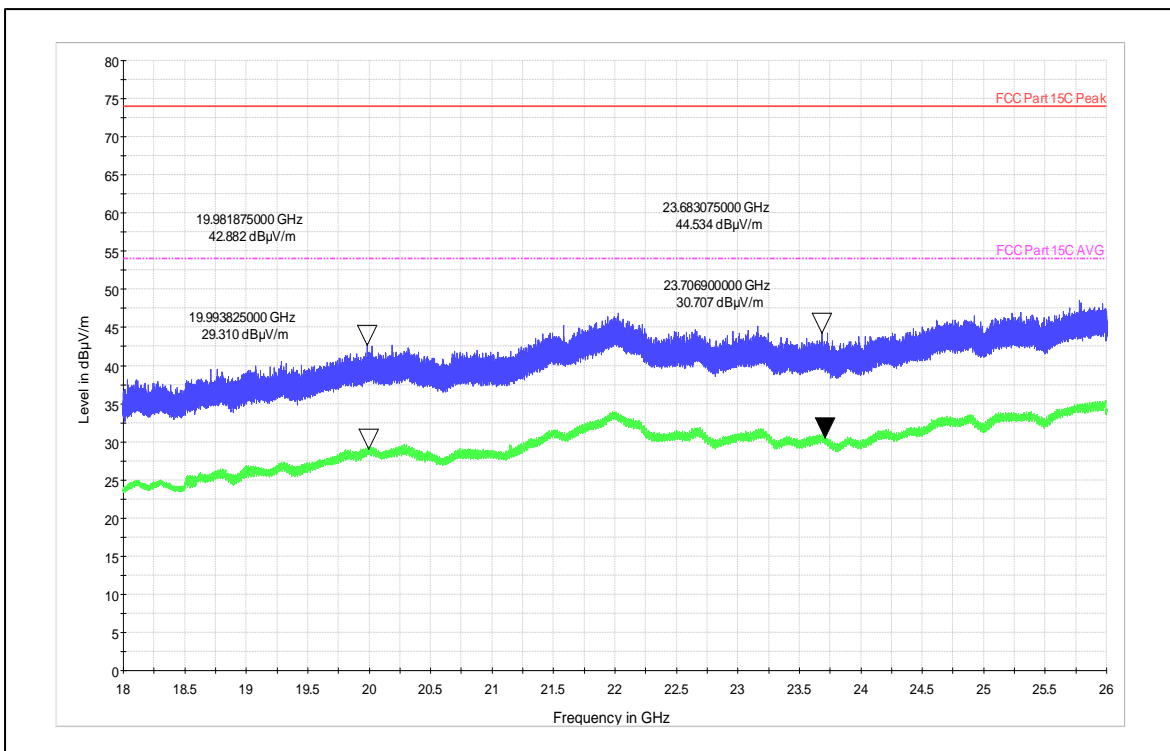

Frequency Range: 18 - 40 GHz

Polarization: Horizontal

**Prüfbericht - Nr.:**  
*Test Report No.:*

**IN23ZC8W 001**

Seite 47 von 50  
Page 47 of 50

## 8 CONDUCTED SPURIOUS EMISSION TEST ON AC POWER LINE

**Result**

**Pass**

Test Specification : FCC Part 15 Section 15.207 / RSS Gen Issue 5 Section 8.8  
Test Method : ANSI C 63.10-2013  
Testing Location : Screened room  
Measurement Bandwidth : 9kHz  
Frequency Range : 150kHz – 30MHz  
Supply Voltage : 110VAC,60Hz  
Test Method : Refer TEST METHODOLOGY

### Limits of section 15.207

Frequency of emission (MHz)	QP Limit (dBµV)	AV Limit (dBµV)
0.15 – 0.5	66 – 56*	56 – 46*
0.5 – 5	56	46
5 – 30	60	50

\* Decreases with the logarithm of the frequency

### Test Conditions:

Normal Temperature = +24°C Voltage (V norm) = 110V AC (Through AC to DC Adapter) Relative Humidity = 64%

**Prüfbericht - Nr.:**  
Test Report No.:

**IN23ZC8W 001**

Seite 48 von 50  
Page 48 of 50

**Test result:**

Power: 110V 60HZ\_LINE

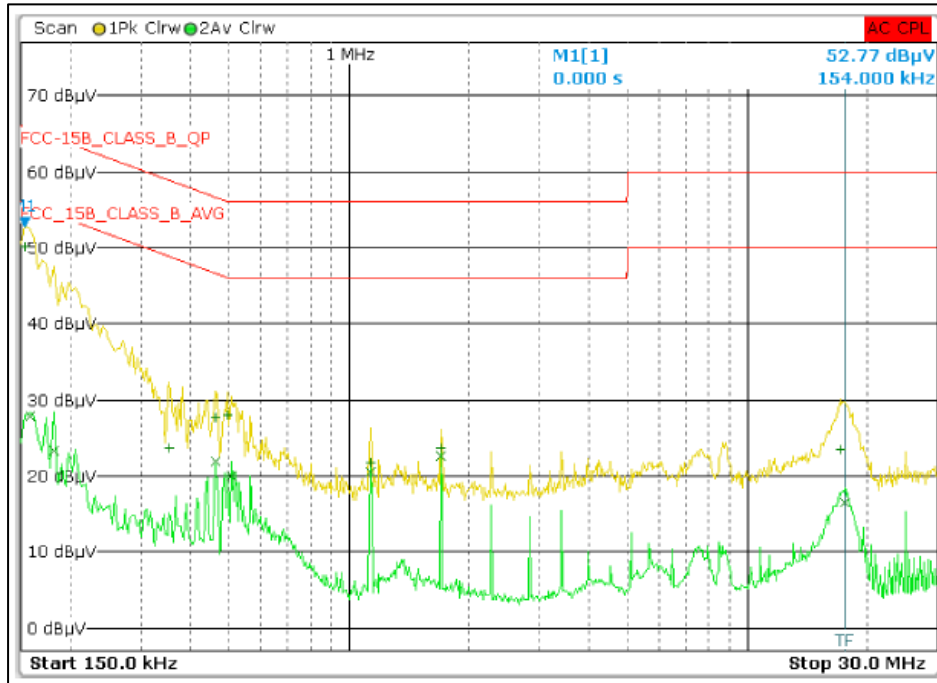

Line Graph

Trace	Frequency	Level (dBµV)	Phase	Detector	Delta Limit/dB
1	154.00000000 kHz	50.20		Quasi Peak	-15.58
2	1.70200000 MHz	22.70		Average	-23.30
2	462.00000000 kHz	21.96		Average	-24.70
2	1.13400000 MHz	20.59		Average	-25.41
2	506.00000000 kHz	19.96		Average	-26.04
2	158.00000000 kHz	27.82		Average	-27.75
1	494.00000000 kHz	27.97		Quasi Peak	-28.13
1	462.00000000 kHz	27.73		Quasi Peak	-28.93
2	182.00000000 kHz	23.32		Average	-31.07
1	1.70200000 MHz	23.69		Quasi Peak	-32.31
2	17.55800000 MHz	16.60		Average	-33.40
1	1.13400000 MHz	21.83		Quasi Peak	-34.17
1	354.00000000 kHz	23.74		Quasi Peak	-35.13
1	17.20600000 MHz	23.44		Quasi Peak	-36.56

Line Table



Power: 110V60Hz\_NEUTRAL

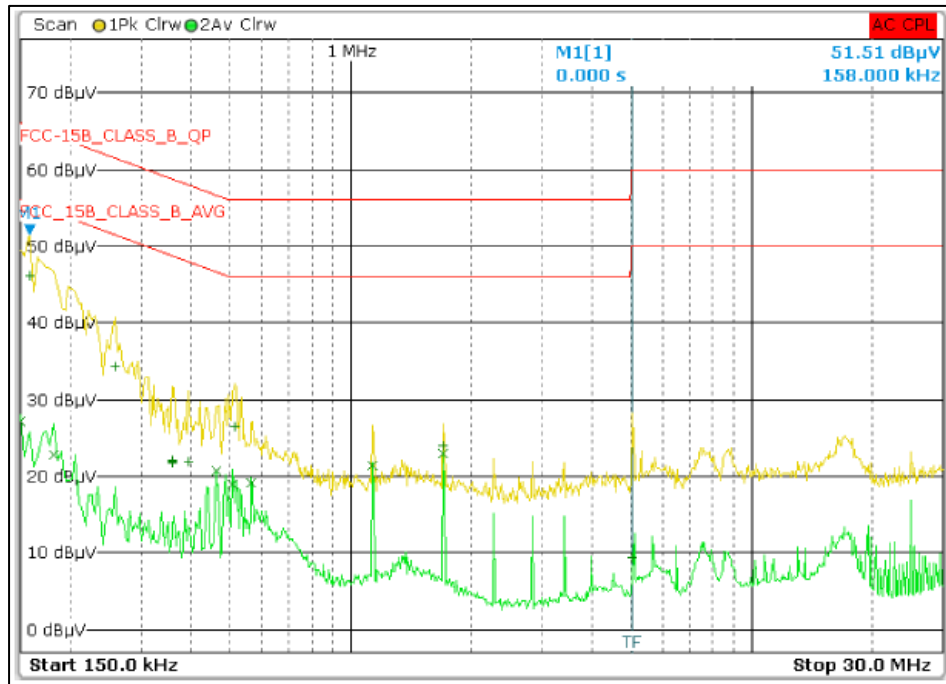

Neutral Graph

Trace	Frequency	Level (dBµV)	Phase	Detector	Delta Limit/dB
1	158.00000000 kHz	46.23		Quasi Peak	-19.34
2	1.70200000 MHz	23.02		Average	-22.98
2	1.13400000 MHz	21.40		Average	-24.60
2	462.00000000 kHz	20.64		Average	-26.02
2	566.00000000 kHz	19.17		Average	-26.83
2	506.00000000 kHz	18.92		Average	-27.08
1	258.00000000 kHz	34.31		Quasi Peak	-27.19
2	150.00000000 kHz	27.21		Average	-28.79
1	514.00000000 kHz	26.41		Quasi Peak	-29.59
2	182.00000000 kHz	22.79		Average	-31.60
1	1.70200000 MHz	24.01		Quasi Peak	-31.99
1	394.00000000 kHz	21.96		Quasi Peak	-36.02
1	394.00000000 kHz	21.90		Quasi Peak	-36.08
1	358.00000000 kHz	22.14		Quasi Peak	-36.63
1	358.00000000 kHz	21.94		Quasi Peak	-36.83
1	358.00000000 kHz	21.68		Quasi Peak	-37.09
1	5.03400000 MHz	9.29		Quasi Peak	-50.71

Neutral Table

## 9 LIST OF TABLES

Table 1: List of test and measurement instruments .....	6
Table 2: Instrument application Software versions .....	6
Table 3: Ratings and System Details as declared by Client* .....	7
Table 4: Measurement Uncertainty .....	8
Table 5: List of Bluetooth center Frequencies .....	9
Table 6: Transmitter limits for Radiated emission .....	32

## 10 LIST OF FIGURES

Figure 1: Frequency Range 9 kHz- 30 MHz .....	13
Figure 2: Frequency Range 30 MHz – 200 MHz .....	13
Figure 3: Frequency Range 200 MHz - 1GHz .....	14
Figure 4: Frequency Range above 1 GHz .....	14

## 11 POWER LEVEL USED FOR TESTING

### Bluetooth 2.4GHz

Channel BandWidth	Data rate (Mbps)	Channel Frequency (MHZ)	1001932PT (Flex/PCB) Antenna	FPA3020-10A (Flex/PCB) Antenna
1MHz	1	2402	16.5	16.5
		2440	16.5	16.5
		2480	16.5	16.5
	2	2402	14.0	14.0
		2440	14.0	14.0
		2480	14.0	14.0
	3	2402	14.0	14.0
		2440	14.0	14.0
		2480	14.0	14.0

\*\*\*\*\*END OF TEST REPORT\*\*\*\*\*