



MEASUREMENT REPORT

FCC PART 15.407/ RSS-247WLAN 802.11a/n/ac

FCC ID: HD5-EDA710
IC: 1693B-EDA710
APPLICANT: Honeywell International Inc
Honeywell Safety and Productivity Solutions

Application Type: Certification
Product: Tablet
Model No.: EDA71-0
Brand Name: Honeywell
FCC Classification: Unlicensed National Information Infrastructure (UNII)
FCC Rule Part(s): Part15 Subpart E (Section 15.407)
IC Rule(s): RSS-247 Issue 2, RSS-GEN Issue 5
Test Procedure(s): ANSI C63.10-2013, KDB 789033 D02v02r01
Test Date: April 21 ~ May 07, 2019

Reviewed By:

Jame Yuan

(Jame Yuan)

Approved By:

Robin Wu

(Robin Wu)



The test results relate only to the samples tested.

This equipment has been shown to be capable of compliance with the applicable technical standards as indicated in the measurement report and was tested in accordance with the measurement procedures specified in KDB 789033 D02v02r01. Test results reported herein relate only to the item(s) tested.

The test report shall not be reproduced except in full without the written approval of MRT Technology (Suzhou) Co., Ltd.

Revision History

Report No.	Version	Description	Issue Date	Note
1904RSU029-U4	Rev. 01	Initial Report	05-12-2019	Valid

CONTENTS

Description	Page
§2.1033 General Information	6
1. INTRODUCTION	7
1.1. Scope	7
1.2. MRT Test Location	7
2. PRODUCT INFORMATION	8
2.1. Equipment Description.....	8
2.2. Product Specification Subjective to this Report.....	9
2.3. Working Frequencies for this Report.....	10
2.4. Test Mode	10
2.5. Device Capabilities	11
2.6. Description of Test Software	12
2.7. Test Configuration	13
2.8. EMI Suppression Device(s)/Modifications	13
2.9. Labeling Requirements.....	13
3. DESCRIPTION OF TEST	14
3.1. Evaluation Procedure	14
3.2. AC Line Conducted Emissions	14
3.3. Radiated Emissions.....	15
4. ANTENNA REQUIREMENTS.....	16
5. TEST EQUIPMENT CALIBRATION DATE.....	17
6. MEASUREMENT UNCERTAINTY.....	19
7. TEST RESULT	20
7.1. Summary	20
7.2. 26dB Bandwidth& 99% Bandwidth Measurement.....	22
7.2.1. Test Limit	22
7.2.2. TestProcedureUsed	22
7.2.3. TestSetting.....	22
7.2.4. Test Setup	22
7.2.5. Test Result.....	23
7.3. 6dB Bandwidth Measurement.....	40
7.3.1. Test Limit	40
7.3.2. Test Procedure Used	40
7.3.3. TestSetting.....	40

7.3.4. Test Setup	40
7.3.5. TestResult.....	41
7.4. Output Power Measurement	46
7.4.1. TestLimit	46
7.4.2. Test Procedure Used	46
7.4.3. Test Setting.....	46
7.4.4. Test Setup	47
7.4.5. TestResult.....	48
7.5. Transmit Power Control	52
7.5.1. Test Limit	52
7.5.2. Test Procedure Used	52
7.5.3. Test Setting.....	52
7.5.4. Test Setup	52
7.5.5. TestResult.....	52
7.6. Power Spectral Density Measurement	53
7.6.1. TestLimit	53
7.6.2. Test Procedure Used	53
7.6.3. Test Setting.....	53
7.6.4. Test Setup	54
7.6.5. Test Result.....	55
7.7. Frequency Stability Measurement.....	73
7.7.1. TestLimit	73
7.7.2. Test Procedure Used	73
7.7.3. Test Setup	74
7.7.4. Test Result.....	75
7.8. Radiated Spurious Emission Measurement	76
7.8.1. Test Limit	76
7.8.2. Test Procedure Used	76
7.8.3. Test Setting.....	76
7.8.4. Test Setup	78
7.8.5. Test Result.....	79
7.9. Radiated RestrictedBand Edge Measurement	145
7.9.1. Test Limit	145
7.9.2. Test Procedure Used	148
7.9.3. Test Setting.....	148
7.9.4. Test Setup	149
7.9.5. Test Result.....	150
7.10. AC Conducted Emissions Measurement.....	256
7.10.1. TestLimit	256

7.10.2. Test Setup 256

7.10.3. Test Result..... 257

8. CONCLUSION..... 259

Appendix A - Test Setup Photograph 260

Appendix B-EUT Photograph..... 261

§2.1033 General Information

Applicant:	Honeywell International Inc Honeywell Safety and Productivity Solutions
Applicant Address:	9680 Old Bailes Road, Fort Mill, SC 29707 United States
Manufacturer:	Honeywell International Inc Honeywell Safety and Productivity Solutions
Manufacturer Address:	9680 Old Bailes Road, Fort Mill, SC 29707 United States
Test Site:	MRT Technology (Suzhou) Co., Ltd
Test Site Address:	D8 Building, No.2 Tian'edang Rd., Wuzhong Economic Development Zone, Suzhou, China
Test Device Serial No.:	S/N: 19077B2BDD (Conducted Sample) S/N: 19077B32EF (Radiated Sample)

Test Facility / Accreditations

Measurements were performed at MRT Laboratory located in Tian'edang Rd., Suzhou, China.

- MRT facility is a FCC registered (MRT Reg. No. 893164) test facility with the site description report on file and has met all the requirements specified in ANSI C63.4-2014.
- MRT facility is an IC registered (MRT Reg. No.11384A-1) test laboratory with the site description on file at Industry Canada.
- MRT facility is a VCCI registered (R-20025, G-20034, C-20020, T-20020) test laboratory with the site description on file at VCCI Council.
- MRT Lab is accredited to ISO 17025 by the American Association for Laboratory Accreditation (A2LA) under the American Association for Laboratory Accreditation Program (A2LACert. No.3628.01) in EMC, Telecommunications, Radio and SAR testing.



1. INTRODUCTION

1.1. Scope

Measurement and determination of electromagnetic emissions (EMC) of radio frequency devices including intentional and/or unintentional radiators for compliance with the technical rules and regulations of the Federal Communications Commission and the Industry Canada Certification and Engineering Bureau.

1.2. MRT Test Location

The map below shows the location of the MRT LABORATORY, its proximity to the Taihu Lake. These measurement tests were conducted at the MRT Technology (Suzhou) Co., Ltd. Facility located at D8 Building, No.2 Tian'edang Rd., Wuzhong Economic Development Zone, Suzhou, China. The measurement facility compliant with the test site requirements specified in ANSI C63.4-2014.



2. PRODUCT INFORMATION

2.1. Equipment Description

Product Name:	Tablet
Model No.:	EDA71-0
Brand Name:	Honeywell
Wi-Fi Specification:	802.11a/b/g/n/ac
Bluetooth Version:	V4.2 dual mode
NFC Specification:	13.56MHz
Accessories	
Adapter:	Model No.: ADS-12B-06 05010E Input Power: 100 - 240V ~ 50/60Hz, Max. 0.3A Output Power: 5VDC 2.0A
USB Charging Cup:	M/N: EDA70-UC
Battery 1#:	Model No.: BAT-EDA50US Capacitance: 15.2Wh, 4000mAh Rated Voltage: 3.8V
Battery 2#:	Model No.: EDA70-EXT Capacitance: 33.45Wh, 8850mAh Rated Voltage: 3.78V

2.2. Product Specification Subjective to this Report

Frequency Range:	For 802.11a/n-HT20/ac-VHT20: 5180~5240MHz, 5260~5320MHz, 5500~5700MHz, 5745~5825MHz For 802.11n-HT40/ac-VHT40: 5190~5230MHz,5270~5310MHz, 5510~5670MHz, 5755~5795MHz For 802.11ac-VHT80: 5210MHz, 5290MHz, 5530MHz, 5610MHz, 5775MHz
Type of Modulation:	802.11a/n/ac: OFDM
Data Rate:	802.11a: 6/9/12/18/24/36/48/54Mbps 802.11n: up to 150Mbps 802.11ac: up to 433.3Mbps
Maximum Average Output Power:	802.11a: 14.22dBm 802.11n-HT20: 12.10dBm 802.11n-HT40: 10.23dBm 802.11ac-VHT20: 12.22dBm 802.11ac-VHT40: 10.23dBm 802.11ac-VHT80: 8.52dBm
Antenna Type:	FPC Antenna
Antenna Gain:	4.59dBi

Note: For other features of this EUT, test report will be issued separately.

2.3. Working Frequencies for this Report

802.11a/n-HT20/ac-VHT20

Channel	Frequency	Channel	Frequency	Channel	Frequency
36	5180 MHz	40	5200 MHz	44	5220 MHz
48	5240 MHz	52	5260 MHz	56	5280 MHz
60	5300 MHz	64	5320 MHz	100	5500 MHz
104	5520 MHz	108	5540 MHz	112	5560 MHz
116	5580 MHz	120	5600 MHz	124	5620 MHz
128	5640 MHz	132	5660 MHz	136	5680 MHz
140	5700 MHz	149	5745 MHz	153	5765 MHz
157	5785 MHz	161	5805 MHz	165	5825 MHz

802.11n-HT40/ac-VHT40

Channel	Frequency	Channel	Frequency	Channel	Frequency
38	5190 MHz	46	5230 MHz	54	5270 MHz
62	5310 MHz	102	5510 MHz	110	5550 MHz
118	5590 MHz	126	5630 MHz	134	5670 MHz
151	5755 MHz	159	5795 MHz	--	--

802.11ac-VHT80

Channel	Frequency	Channel	Frequency	Channel	Frequency
42	5210 MHz	58	5290 MHz	106	5530 MHz
122	5610 MHz	155	5775 MHz	--	--

Note: The frequencies that fall in the 5600MHz to 5650MHz band will not be used in Canada.

2.4. Test Mode

Test Mode	Mode 1: Transmit by 802.11a (6Mbps)
	Mode 2: Transmit by 802.11n-HT20 (MCS0)
	Mode 3: Transmit by 802.11n-HT40 (MCS0)
	Mode 4: Transmit by 802.11ac-VHT20 (MCS0)
	Mode 5: Transmit by 802.11ac-VHT40 (MCS0)
	Mode 6: Transmit by 802.11ac-VHT80 (MCS0)

2.5. Device Capabilities

This device contains the following capabilities:

2.4GHz WLAN (DTS), 5GHz WLAN (UNII), Bluetooth v4.2 (DSS, DTS) and NFC.

Note:5GHz (NII) operation is possible in 20MHz, 40MHz and 80MHz channel bandwidths. The maximum achievable duty cycles for all modes were determined based on measurements performed on a spectrum analyzer in zero-span mode with RBW = 8MHz, VBW = 50MHz. The RBW and VBW were both greater than $50/T$, where T is the minimum transmission duration, and the number of sweep points across T was greater than 100. The duty cycles are as follows:

Test Mode	Duty Cycle
802.11a	83.02%
802.11n-HT20	82.56%
802.11n-HT40	70.74%
802.11ac-VHT20	82.91%
802.11ac-VHT40	71.00%
802.11ac-VHT80	55.36%

Duty Cycle (T = Transmission Duration)

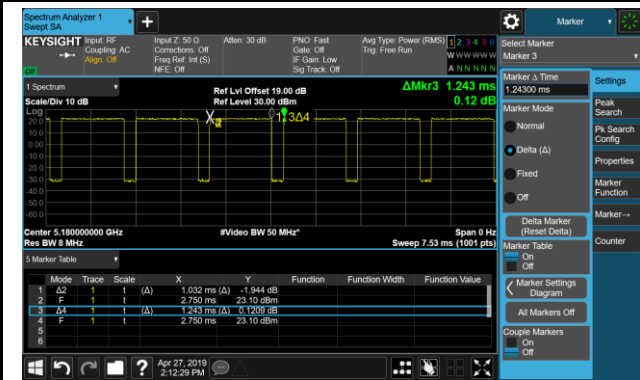
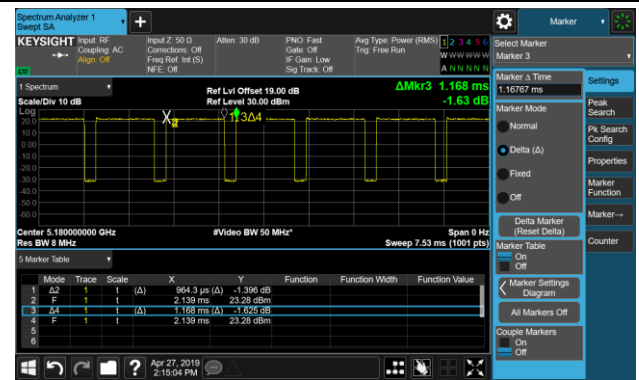
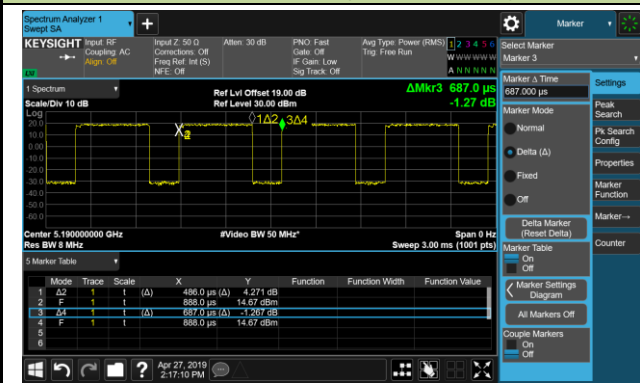
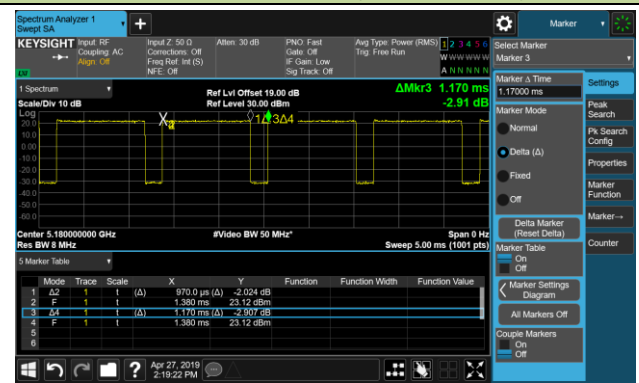
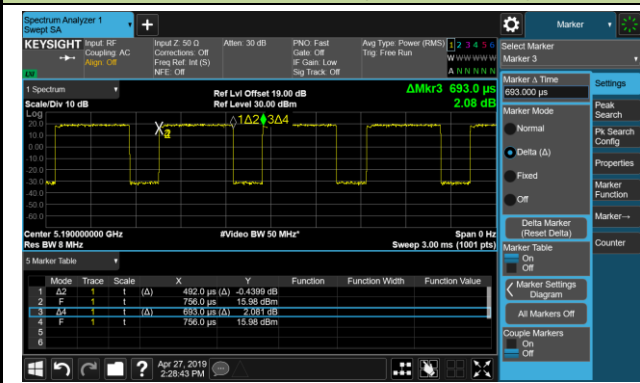
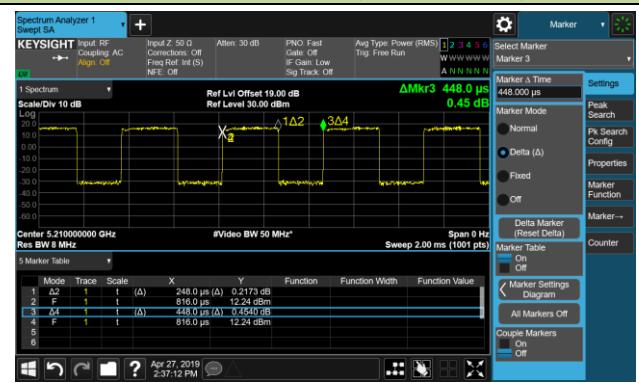
802.11a (T = 1.032ms)

802.11n-HT20 (T = 964.3μs)

802.11n-HT40 (T = 486.0μs)

802.11ac-VHT20 (T = 970.0μs)

802.11ac-VHT40 (T = 492.0μs)

802.11ac-VHT80 (T = 248.0μs)

2.6. Description of Test Software

The test utility software used during testing was "QRCT", and the version was 3.0.268.0.

Power parameter value refer to operation description.

2.7. Test Configuration

The **Tablet** was tested per the guidance of KDB 789033 D02v02r01. ANSI C63.10-2013 was used to reference the appropriate EUT setup for radiated spurious emissions testing and AC line conducted testing.

2.8. EMI Suppression Device(s)/Modifications

No EMI suppression device(s) were added and/or no modifications were made during testing.

2.9. Labeling Requirements

Per 2.1074 & 15.19; Docket 95-19

The label shall be permanently affixed at a conspicuous location on the device; instruction manual or pamphlets supplied to the user and be readily visible to the purchaser at the time of purchase.

However, when the device is so small wherein placement of the label with specified statement is not practical, only the FCC ID must be displayed on the device per Section 15.19(a)(5). Please see attachment for FCC ID label and label location.

RSP-100 Issue 11 Section 3

The manufacturer, importer or distributor shall meet the labeling requirements set out in this section for every unit:

- (i) prior to marketing in Canada, for products manufactured in Canada
- (ii) prior to importation into Canada, for imported products

For information regarding the e-labeling option, see Notice 2014-DRS1003. The label for the certified product represents the manufacturer's or importer's compliance with Innovation, Science and Economic Development Canada's (ISED) regulatory requirements.

Please see attachment for IC label and label location.

3. DESCRIPTION OF TEST

3.1. Evaluation Procedure

The measurement procedures described in the American National Standard of Procedures for Compliance Testing of Unlicensed Wireless Devices (ANSI C63.10-2013), and the guidance provided in KDB 789033 D02v02r01 were used in the measurement.

Deviation from measurement procedure.....None

3.2. AC Line Conducted Emissions

The line-conducted facility is located inside an 8'x4'x4' shielded enclosure. A 1m x 2m wooden table 80cm high is placed 40cm away from the vertical wall and 80cm away from the sidewall of the shielded room. Two 10kHz-30MHz, 50Ω/50uH Line-Impedance Stabilization Networks (LISNs) are bonded to the shielded room floor. Power to the LISNs is filtered by external high-current high-insertion loss power line filters. These filters attenuate ambient signal noise from entering the measurement lines. These filters are also bonded to the shielded enclosure.

The EUT is powered from one LISN and the support equipment is powered from the second LISN. All interconnecting cables more than 1 meter were shortened to a 1 meter length by non-inductive bundling (serpentine fashion) and draped over the back edge of the test table. All cables were at least 40cm above the horizontal reference ground-plane. Power cables for support equipment were routed down to the second LISN while ensuring that that cables were not draped over the second LISN.

Sufficient time for the EUT, support equipment, and test equipment was allowed in order for them to warm up to their normal operating condition. The RF output of the LISN was connected to the receiver and exploratory measurements were made to determine the frequencies producing the maximum emission from the EUT. The receiver was scanned from 150kHz to 30MHz. The detector function was set to peak mode for exploratory measurements while the bandwidth of the analyzer was set to 9kHz. The EUT, support equipment, and interconnecting cables were arranged and manipulated to maximize each emission. Each emission was also maximized by varying: power lines, the mode of operation or data exchange speed, or support equipment whichever determined the worst-case emission. Once the worst case emissions have been identified, the one EUT cable configuration/arrangement and mode of operation that produced these emissions are used for final measurements on the same test site. The analyzer is set to CISPR quasi-peak and average detectors with a 9kHz resolution bandwidth for final measurements.

An extension cord was used to connect to a single LISN which powered by EUT. The extension cord was calibrated with LISN, the impedance and insertion loss are compliance with the requirements as stated in ANSI C63.10-2013.

3.3. Radiated Emissions

The radiated test facilities consisted of an indoor 3 meter semi-anechoic chamber used for final measurements and exploratory measurements, when necessary. The measurement area is contained within the semi-anechoic chamber which is shielded from any ambient interference. For measurements above 1GHz absorbers are arranged on the floor between the turn table and the antenna mast in such a way so as to maximize the reduction of reflections. For measurements below 1GHz, the absorbers are removed. A MF Model 210SS turntable is used for radiated measurement. It is a continuously rotatable, remotecontrolled, metallic turntable and 2 meters (6.56 ft.) in diameter. The turn table is flush with the raised floor of the chamber in order to maintain its function as a ground plane. An 80cm high PVC support structure is placed on top of the turntable.

For all measurements, the spectrum was scanned through all EUT azimuths and from 1 to 4 meter receive antenna height using a broadband antenna from 30MHz up to the upper frequency shown in 15.33(b)(1) depending on the highest frequency generated or used in the device or on which the device operates or tunes. For frequencies above 1GHz, linearly polarized double ridge horn antennas were used. For frequencies below 30MHz, a calibrated loop antenna was used. When exploratory measurements were necessary, they were performed at 1 meter test distance inside the semi-anechoic chamber using broadband antennas, broadband amplifiers, and spectrum analyzers to determine the frequencies and modes producing the maximum emissions. Sufficient time for the EUT, support equipment, and test equipment was allowed in order for them to warm up to their normal operating condition. The test set-up for frequencies below 1GHz was placed on top of the 0.8 meter high, 1 x 1.5 meter table; and test set-up for frequencies 1-40GHz was placed on top of the 1.5 meter high, 1 x 1.5 meter table. The EUT, support equipment, and interconnecting cables were arranged and manipulated to maximize each emission. Appropriate precaution was taken to ensure that all emissions from the EUT were maximized and investigated. The system configuration, clock speed, mode of operation or video resolution, if applicable, turntable azimuth, and receive antenna height was noted for each frequency found.

Final measurements were made in the semi-anechoic chamber using calibrated, linearly polarized broadband and horn antennas. The test setup was configured to the setup that produced the worst case emissions. The spectrum analyzer was set to investigate all frequencies required for testing to compare the highest radiated disturbances with respect to the specified limits. The turntable containing the EUT was rotated through 360 degrees and the height of the receive antenna was varied 1 to 4 meters and stopped at the azimuth and height producing the maximum emission. Each emission was maximized by changing the orientation of the EUT through three orthogonal planes and changing the polarity of the receive antenna, whichever produced the worst-case emissions. According to 3dB Beam-Width of horn antenna, the horn antenna should be always directed to the EUT when rising height.

4. ANTENNA REQUIREMENTS

Excerpt from §15.203 of the FCC Rules/Regulations:

“An intentional radiator antenna shall be designed to ensure that no antenna other than that furnished by the responsible party can be used with the device. The use of a permanently attached antenna or of an antenna that uses a unique coupling to the intentional radiator shall be considered sufficient to comply with the provisions of this section.”

- The antenna of the **Tablet** is **permanently attached**.
- There are no provisions for connection to an external antenna.

Conclusion:

The **Tablet** unit complies with the requirement of §15.203.

5. TEST EQUIPMENT CALIBRATION DATE

Conducted Emissions - SR2

Instrument	Manufacturer	Type No.	Asset No.	Cali. Interval	Cali. Due Date
EMI Test Receiver	R&S	ESR3	MRTSUE06185	1 year	2020/04/15
Two-Line V-Network	R&S	ENV 216	MRTSUE06002	1 year	2019/06/14
Two-Line V-Network	R&S	ENV 216	MRTSUE06003	1 year	2019/06/14
Thermohygrometer	testo	608-H1	MRTSUE06404	1 year	2019/08/14
Shielding Room	MIX-BEP	Chamber-SR2	MRTSUE06215	N/A	N/A

Radiated Emissions - AC1

Instrument	Manufacturer	Type No.	Asset No.	Cali. Interval	Cali. Due Date
EMI Test Receiver	R&S	ESR7	MRTSUE06001	1 year	2019/08/13
EXA Signal Analyzer	Agilent	N9020A	MRTSUE06106	1 year	2020/04/15
Loop Antenna	Schwarzbeck	FMZB 1519	MRTSUE06025	1 year	2019/11/09
Bilog Period Antenna	Schwarzbeck	VULB 9168	MRTSUE06172	1 year	2020/03/31
Broad Band Horn Antenna	Schwarzbeck	BBHA9120D	MRTSUE06023	1 year	2019/10/19
Broad Band Horn Antenna	Schwarzbeck	BBHA9170	MRTSUE06024	1 year	2019/12/17
Microwave System Amplifier	Agilent	83017A	MRTSUE06076	1 year	2019/11/16
Preamplifier	Schwarzbeck	BBV 9721	MRTSUE06121	1 year	2019/06/12
Thermohygrometer	Testo	608-H1	MRTSUE06403	1 year	2019/08/14
Anechoic Chamber	TDK	Chamber-AC1	MRTSUE06212	1 year	2020/04/30

Radiated Emission - AC2

Instrument	Manufacturer	Type No.	Asset No.	Cali. Interval	Cali. Due Date
MXE EMI Receiver	Agilent	N9038A	MRTSUE06125	1 year	2019/08/13
Loop Antenna	Schwarzbeck	FMZB 1519	MRTSUE06025	1 year	2019/11/09
Bilog Period Antenna	Schwarzbeck	VULB 9162	MRTSUE06022	1 year	2019/10/19
Broad-Band Horn Antenna	Schwarzbeck	BBHA9120D	MRTSUE06171	1 year	2019/11/09
Broad Band Horn Antenna	Schwarzbeck	BBHA9170	MRTSUE06024	1 year	2019/12/17
Broadband Coaxial Preamplifier	Schwarzbeck	BBV 9718	MRTSUE06176	1 year	2019/11/16
Preamplifier	Schwarzbeck	BBV 9721	MRTSUE06121	1 year	2019/06/12
Digital Thermometer & Hygrometer	Minggao	ETH529	MRTSUE06170	1 year	2019/12/13
Anechoic Chamber	RIKEN	Chamber-AC2	MRTSUE06213	1 year	2020/04/30

Conducted Test Equipment - TR3

Instrument	Manufacturer	Type No.	Asset No.	Cali. Interval	Cali. Due Date
EXA Signal Analyzer	Keysight	N9010A	MRTSUE06195	1 year	2020/04/15
EXA Signal Analyzer	Keysight	N9010B	MRTSUE06452	1 year	2019/07/19
EXA Signal Analyzer	Agilent	N9020A	MRTSUE06106	1 year	2020/04/15
Signal Analyzer	R&S	FSV40	MRTSUE06218	1 year	2020/04/15
Power Meter	Agilent	U2021XA	MRTSUE06030	1 year	2019/11/16
USB wideband power sensor	Keysight	U2021XA	MRTSUE06446	1 year	2019/07/19
USB wideband power sensor	Keysight	U2021XA	MRTSUE06447	1 year	2019/07/05
Bluetooth Test Set	Anritsu	MT8852B-042	MRTSUE06389	1 year	2019/06/14
Audio Analyzer	Agilent	U8903B	MRTSUE06143	1 year	2019/08/14
Modulation Analyzer	Hewlett Packard	HP8901A	MRTSUE06098	1 year	2019/10/18
Wideband Radio Communication Tester	R&S	CMW 500	MRTSUE06243	1 year	2019/11/16
DC Power Supply	GWINSTEK	DPS-3303C	MRTSUE06064	N/A	N/A
Temperature & Humidity Chamber	BAOYT	BYH-150CL	MRTSUE06051	1 year	2019/11/16
Thermohygrometer	Testo	608-H1	MRTSUE06401	1 year	2019/08/14

Software	Version	Function
EMI Software	V3	EMI Test Software

6. MEASUREMENT UNCERTAINTY

Where relevant, the following test uncertainty levels have been estimated for tests performed on the EUT as specified in CISPR 16-4-2. This uncertainty represents an expanded uncertainty expressed at approximately the 95% confidence level using a coverage factor of $k = 2$.

AC Conducted Emission Measurement - SR2
Measuring Uncertainty for a Level of Confidence of 95% ($U=2Uc(y)$): 9kHz~150kHz: 3.84dB 150kHz~30MHz: 3.46dB
Radiated Emission Measurement- AC1
Measuring Uncertainty for a Level of Confidence of 95% ($U=2Uc(y)$): Horizontal: 30MHz~300MHz: 4.07dB 300MHz~1GHz: 3.63dB 1GHz~18GHz: 4.16dB Vertical: 30MHz~300MHz: 4.18dB 300MHz~1GHz: 3.60dB 1GHz~18GHz: 4.76dB
Radiated Emission Measurement- AC2
Measuring Uncertainty for a Level of Confidence of 95% ($U=2Uc(y)$): Horizontal: 30MHz~300MHz: 3.75dB 300MHz~1GHz: 3.53dB 1GHz~18GHz: 4.28dB Vertical: 30MHz~300MHz: 3.86dB 300MHz~1GHz: 3.53dB 1GHz~18GHz: 4.33dB

7. TEST RESULT

7.1. Summary

FCC Section(s)	Test Description	Test Limit	Test Condition	Test Result	Reference
15.407(a)	26dB Bandwidth	N/A	Conducted	Pass	Section7.2
15.407(e)	6dB Bandwidth	$\geq 500\text{kHz}$		Pass	Section 7.3
15.407(a)(1)(iv), (2),(3)	Maximum Conducted Output Power	U-NII-1: $\leq 250\text{mW}$ U-NII-2: $\leq 250\text{mW}$ or $11 + 10\log_{10}B$ U-NII-3: $\leq 1\text{W}$		Pass	Section 7.4
15.407(h)(1)	Transmit Power Control	$\leq 24\text{dBm}$		N/A	Section 7.5
15.407(a)(1)(iv), (2), (3), (5)	Peak Power Spectral Density	U-NII-1&U-NII-2: $\leq 11\text{dBm/MHz}$ U-NII-3: $\leq 30\text{dBm}/500\text{kHz}$		Pass	Section 7.6
15.407(g)	Frequency Stability	N/A		Pass	Section 7.7
15.407(b)(1), (2), (3), (4)(i)	Undesirable Emissions	$\leq -27\text{dBm/MHz}$ EIRP Detail see section 7.9	Radiated	Pass	Section 7.8 Section7.9
15.205, 15.209 15.407(b)(5), (6), (7)	General Field Strength Limits(Restricted Bands and Radiated Emission Limits)	Emissions in restricted bands must meet the radiated limits detailed in15.209		Pass	
15.207	AC Conducted Emissions 150kHz-30MHz	< FCC 15.207 limits	Line Conducted	Pass	Section 7.10

RSS Section(s)	Test Description	Test Limit	Test Condition	Test Result	Reference
RSS-247 §6.2	99% Bandwidth	N/A	Conducted	Pass	Section 7.2
RSS-247 §6.2.4	6dB Bandwidth	≥ 500kHz		Pass	Section 7.3
RSS-247 §6.2.1, §6.2.2, §6.2.3, §6.2.4	Max Conducted Output Power	5250~5350MHz, 5470~5725MHz: ≤ 250mW or 11 + 10 log ₁₀ B 5725~5850MHz: ≤ 1W		Pass	Section 7.4
	Maximum E.I.R.P	5150~5250MHz: ≤ 200mW or 10 + 10 log ₁₀ B 5250~5350, 5470~5725MHz: ≤ 1W or 17 + 10 log ₁₀ B			
RSS-247 §6.2.2, §6.2.3	Transmit Power Control	≤ 24dBm		N/A	Section 7.5
RSS-247 §6.2.1, §6.2.2, §6.2.3, §6.2.4	Peak Power Spectral Density	5150~5250MHz: ≤ 10dBm/MHz 5250~5250, 5470~5725MHz: ≤ 11dBm/MHz 5725~5850MHz: ≤ 30dBm/500kHz		Pass	Section 7.6
RSS-Gen [8.11]	Frequency Stability	N/A	Pass	Section 7.7	
RSS-247 §6.2.1, §6.2.2, §6.2.3, §6.2.4	Out-of-Band Emissions	Refer to section 7.8	Radiated	Pass	Section 7.8 Section 7.9
RSS-247 §6.2.1, §6.2.2, §6.2.3, §6.2.4	General Field Strength Limits(Restricted Bands and Radiated Emission Limits)	Emissions in restricted bands must meet the radiated limits detailed in 15.209		Pass	
RSS-Gen [8.8]	AC Conducted Emissions 150kHz-30MHz	< RSS-Gen [8.8] limits	Line Conducted	Pass	Section 7.10

Notes:

- 1) The analyzer plots shown in this section were all taken with a correction table loaded into the analyzer. The correction table was used to account for the losses of the cables and attenuators used as part of the system to connect the EUT to the analyzer at all frequencies of interest.
- 2) All modes of operation and data rates were investigated. For radiated emission test, every axis (X, Y, Z) was also verified. The test results shown in the following sections represent the worst case emissions.

7.2. 26dB Bandwidth & 99% Bandwidth Measurement

7.2.1. Test Limit

N/A

7.2.2. Test Procedure Used

ANSI C63.10-2013-Section 6.9.2 & 6.9.3

7.2.3. Test Setting

1. The analyzers' automatic bandwidth measurement capability was used to perform the 26dB bandwidth measurement. The "X" dB bandwidth parameter was set to $X = 26$. The automatic bandwidth measurement function also has the capability of simultaneously measuring the 99% occupied bandwidth. The bandwidth measurement was not influenced by any intermediated power nulls in the fundamental emission.
2. RBW = Approximately 1% of the emission bandwidth.
3. VBW $\geq 3 \times$ RBW.
4. Detector = Peak.
5. Trace mode = Max hold.

7.2.4. Test Setup

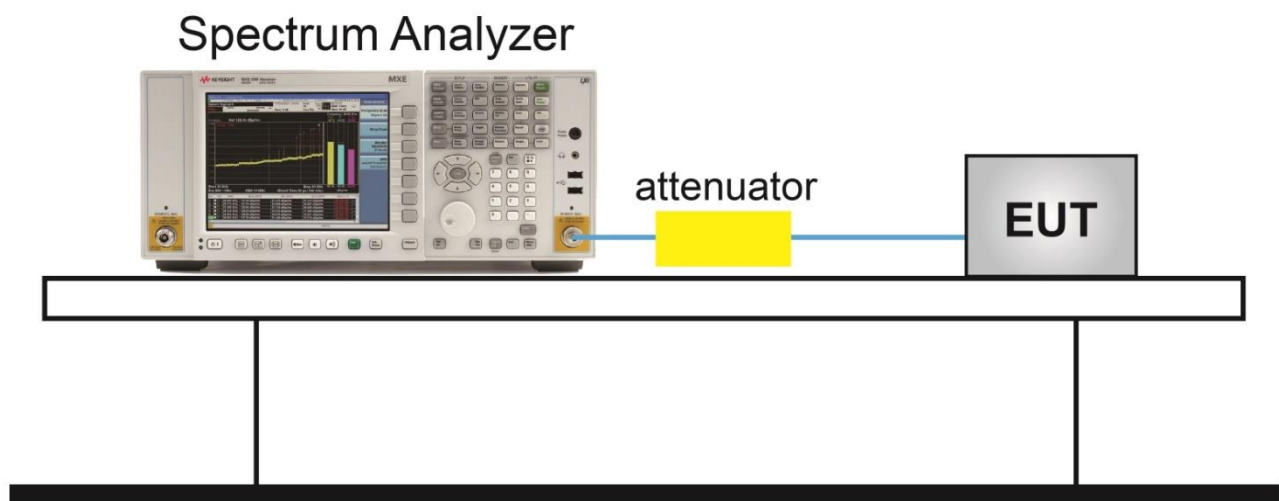

7.2.5.Test Result

Product	Tablet	Temperature	25°C
Test Engineer	Flag Yang	Relative Humidity	52%
Test Site	TR3	Test Date	2019/04/27

Test Mode	Data Rate/ MCS	Channel No.	Frequency (MHz)	26dB Bandwidth (MHz)	99% Bandwidth (MHz)
802.11a	6Mbps	36	5180	21.97	16.90
802.11a	6Mbps	44	5220	21.96	16.88
802.11a	6Mbps	48	5240	21.94	16.77
802.11a	6Mbps	52	5260	21.64	16.79
802.11a	6Mbps	60	5300	22.10	16.76
802.11a	6Mbps	64	5320	22.02	16.86
802.11a	6Mbps	100	5500	21.65	16.80
802.11a	6Mbps	116	5580	21.64	16.79
802.11a	6Mbps	120	5600	21.65	16.81
802.11a	6Mbps	140	5700	21.87	16.85
802.11a	6Mbps	149	5745	21.93	16.78
802.11a	6Mbps	157	5785	21.56	16.84
802.11a	6Mbps	165	5825	21.40	16.85
802.11n-HT20	MCS0	36	5180	21.93	17.89
802.11n-HT20	MCS0	44	5220	22.15	17.83
802.11n-HT20	MCS0	48	5240	22.19	17.90
802.11n-HT20	MCS0	52	5260	21.90	17.87
802.11n-HT20	MCS0	60	5300	22.01	17.87
802.11n-HT20	MCS0	64	5320	21.98	17.86
802.11n-HT20	MCS0	100	5500	21.94	17.84
802.11n-HT20	MCS0	116	5580	21.80	17.83
802.11n-HT20	MCS0	120	5600	21.97	17.86
802.11n-HT20	MCS0	140	5700	21.75	17.87
802.11n-HT20	MCS0	149	5745	22.00	17.84
802.11n-HT20	MCS0	157	5785	21.95	17.87
802.11n-HT20	MCS0	165	5825	21.94	17.83

Test Mode	Data Rate/ MCS	Channel No.	Frequency (MHz)	26dB Bandwidth (MHz)	99% Bandwidth (MHz)
802.11n-HT40	MCS0	38	5190	42.77	36.29
802.11n-HT40	MCS0	46	5230	43.48	36.28
802.11n-HT40	MCS0	54	5270	43.61	36.30
802.11n-HT40	MCS0	62	5310	42.45	36.26
802.11n-HT40	MCS0	102	5510	43.05	36.23
802.11n-HT40	MCS0	110	5550	42.69	36.27
802.11n-HT40	MCS0	118	5590	43.72	36.26
802.11n-HT40	MCS0	134	5670	43.26	36.22
802.11n-HT40	MCS0	151	5755	43.24	36.19
802.11n-HT40	MCS0	159	5795	43.07	36.16
802.11ac-VHT20	MCS0	36	5180	21.80	17.90
802.11ac-VHT20	MCS0	44	5220	21.78	17.90
802.11ac-VHT20	MCS0	48	5240	21.84	17.88
802.11ac-VHT20	MCS0	52	5260	21.67	17.86
802.11ac-VHT20	MCS0	60	5300	21.69	17.85
802.11ac-VHT20	MCS0	64	5320	21.94	17.88
802.11ac-VHT20	MCS0	100	5500	21.56	17.88
802.11ac-VHT20	MCS0	116	5580	21.86	17.89
802.11ac-VHT20	MCS0	120	5600	21.80	17.84
802.11ac-VHT20	MCS0	140	5700	21.53	17.86
802.11ac-VHT20	MCS0	149	5745	21.81	17.86
802.11ac-VHT20	MCS0	157	5785	21.91	17.90
802.11ac-VHT20	MCS0	165	5825	21.68	17.88

Test Mode	Data Rate/ MCS	Channel No.	Frequency (MHz)	26dB Bandwidth (MHz)	99% Bandwidth (MHz)
802.11ac-VHT40	MCS0	38	5190	42.49	36.30
802.11ac-VHT40	MCS0	46	5230	42.68	36.22
802.11ac-VHT40	MCS0	54	5270	42.25	36.23
802.11ac-VHT40	MCS0	62	5310	42.00	36.19
802.11ac-VHT40	MCS0	102	5510	42.18	36.15
802.11ac-VHT40	MCS0	110	5550	42.36	36.21
802.11ac-VHT40	MCS0	118	5590	42.46	36.19
802.11ac-VHT40	MCS0	134	5670	42.22	36.17
802.11ac-VHT40	MCS0	151	5755	42.27	36.22
802.11ac-VHT40	MCS0	159	5795	42.11	36.25
802.11ac-VHT80	MCS0	42	5210	83.90	74.91
802.11ac-VHT80	MCS0	58	5290	83.23	74.84
802.11ac-VHT80	MCS0	106	5530	83.60	74.95
802.11ac-VHT80	MCS0	122	5610	84.20	74.90
802.11ac-VHT80	MCS0	155	5775	83.43	74.89

802.11a 26dB Bandwidth & 99% Bandwidth

Channel 36 (5180MHz)

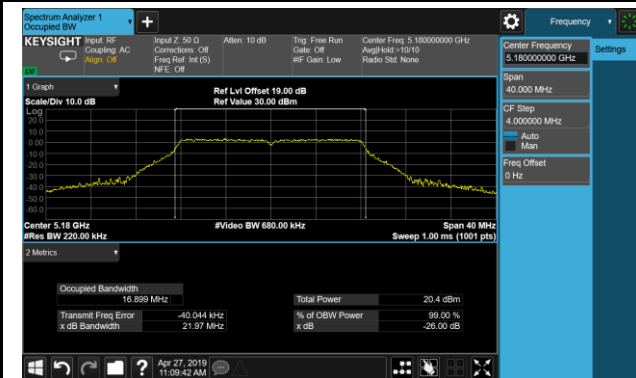

Channel 44 (5220MHz)

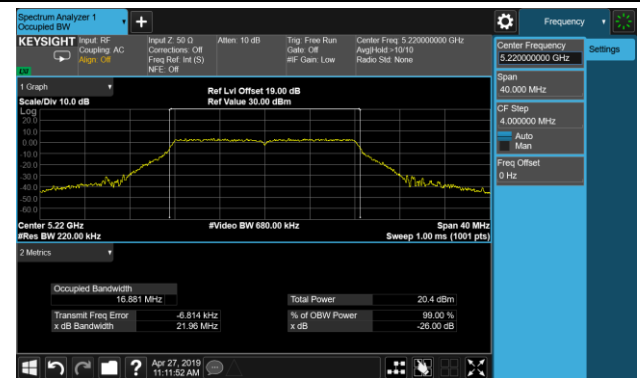

Channel 48 (5240MHz)

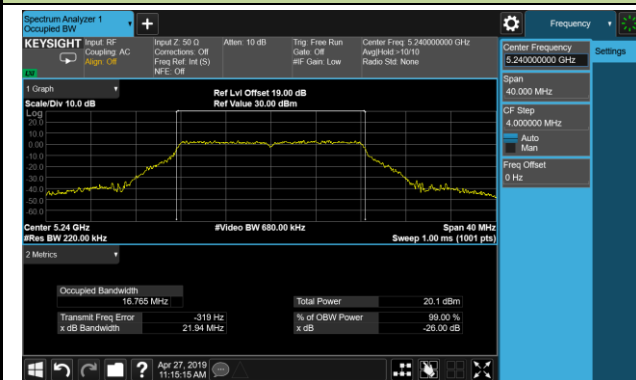

Channel 52 (5260MHz)

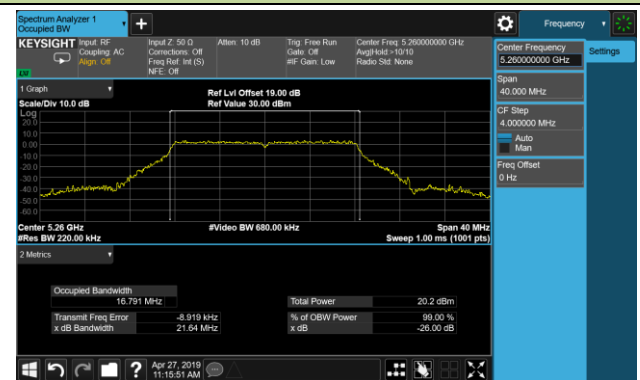

Channel 60 (5300MHz)

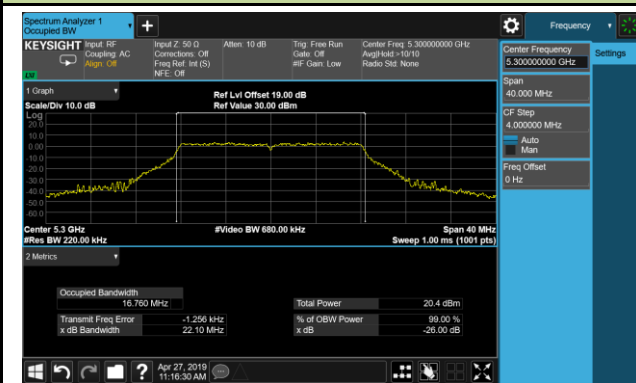

Channel 64 (5320MHz)

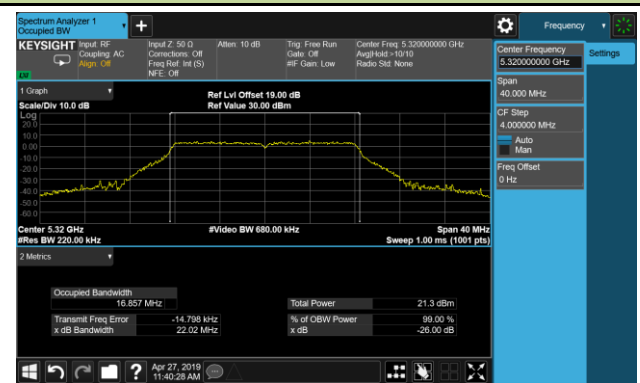

802.11a 26dB Bandwidth & 99% Bandwidth

Channel 100 (5500MHz)

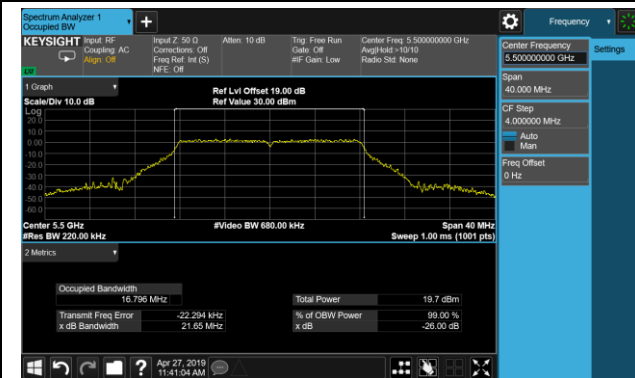

Channel 116 (5580MHz)

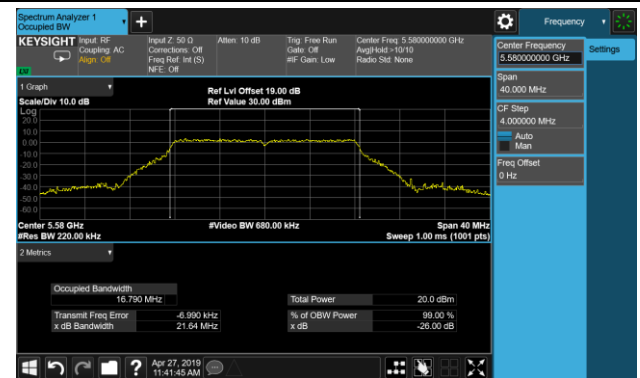

Channel 120 (5600MHz)

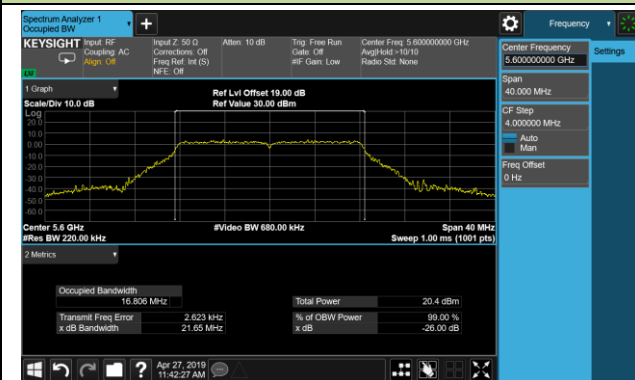

Channel 140 (5700MHz)

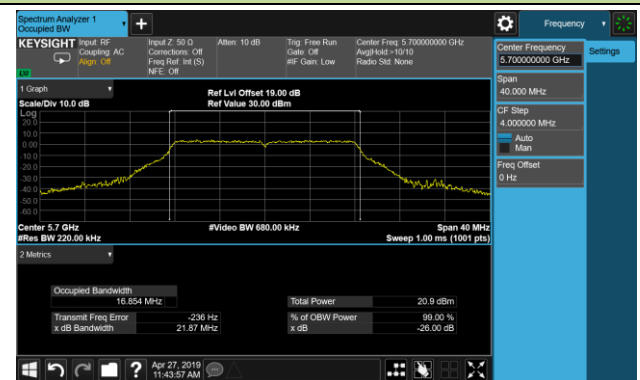

Channel 149 (5745MHz)

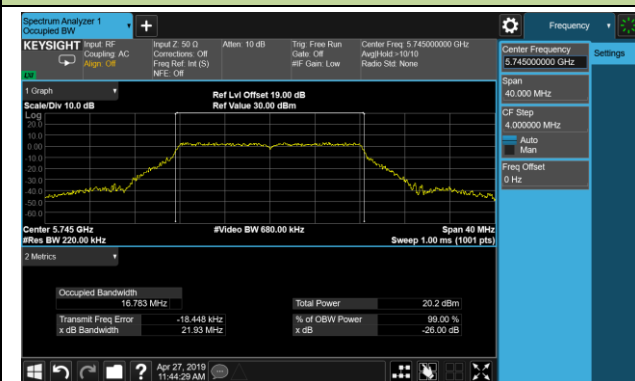

Channel 157 (5785MHz)

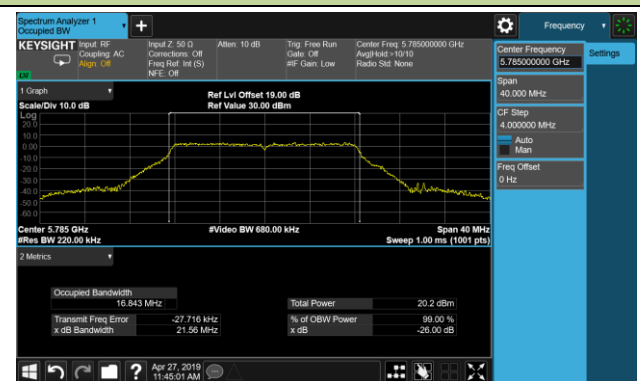

802.11a 26dB Bandwidth & 99% Bandwidth

Channel 165 (5825MHz)



802.11n-HT20 26dB Bandwidth & 99% Bandwidth

Channel 36 (5180MHz)

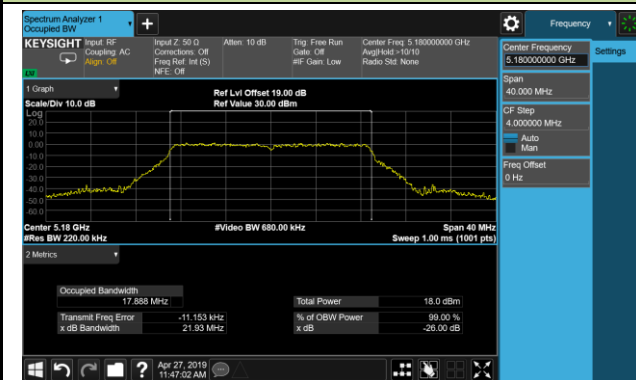

Channel 44 (5220MHz)

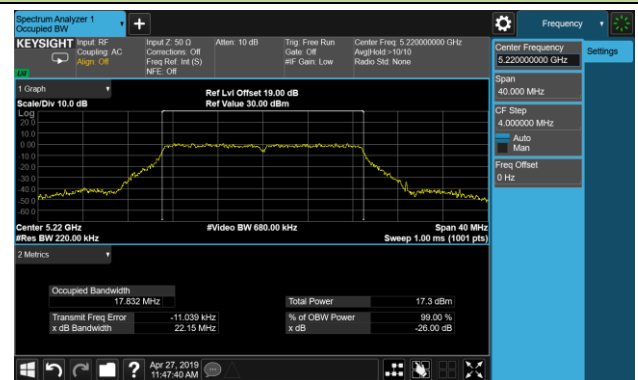

Channel 48 (5240MHz)

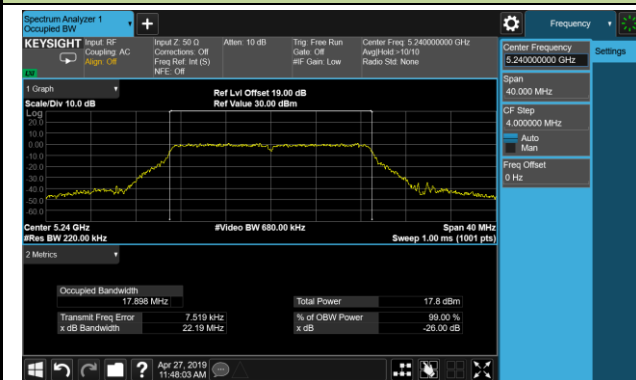

Channel 52 (5260MHz)

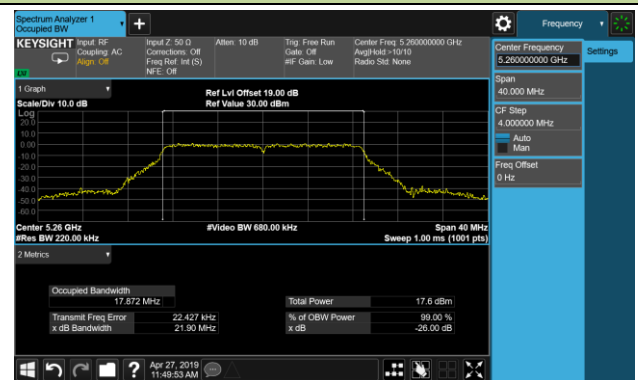

Channel 60 (5300MHz)



Channel 64 (5320MHz)



802.11n-HT20 26dB Bandwidth & 99% Bandwidth

Channel 100 (5500MHz)

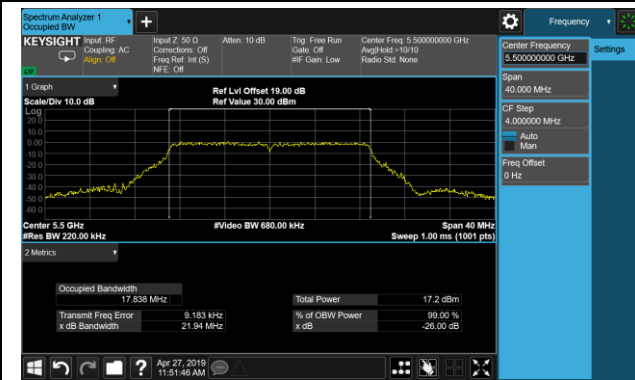

Channel 116 (5580MHz)

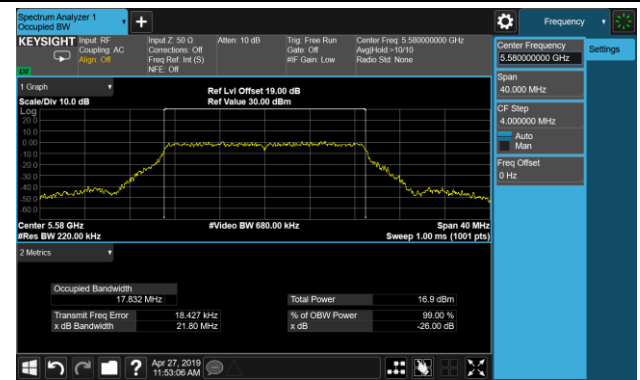

Channel 120 (5600MHz)



Channel 140 (5700MHz)

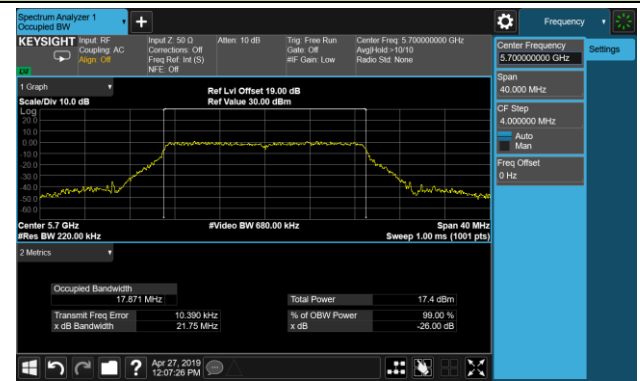

Channel 149 (5745MHz)

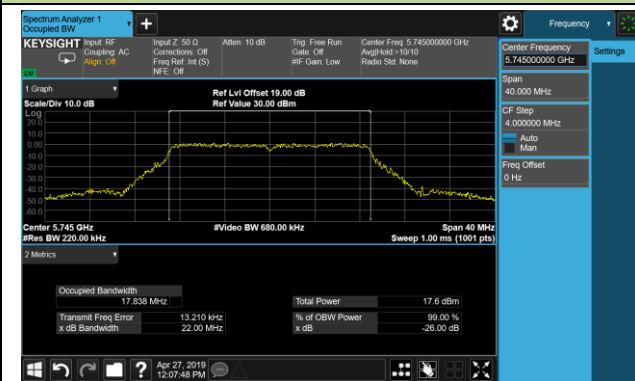

Channel 157 (5785MHz)



802.11n-HT20 26dB Bandwidth & 99% Bandwidth

Channel 165 (5825MHz)



802.11n-HT40 26dB Bandwidth & 99% Bandwidth

Channel 38 (5190MHz)

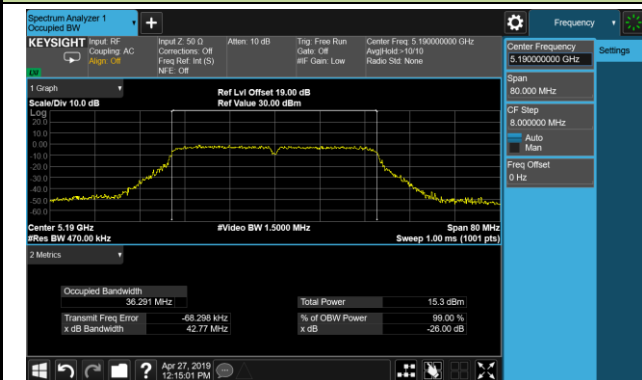

Channel 46 (5230MHz)

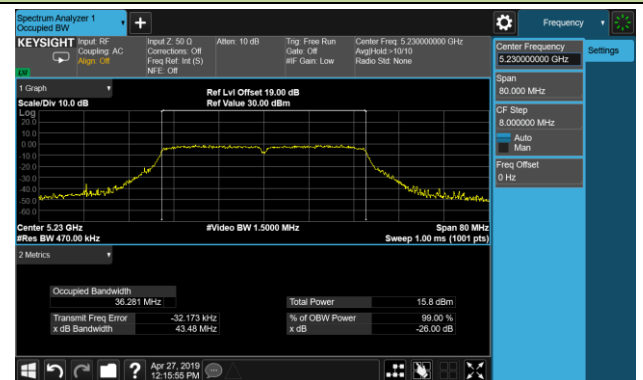

Channel 54 (5270MHz)



Channel 62 (5310MHz)



Channel 102 (5510MHz)

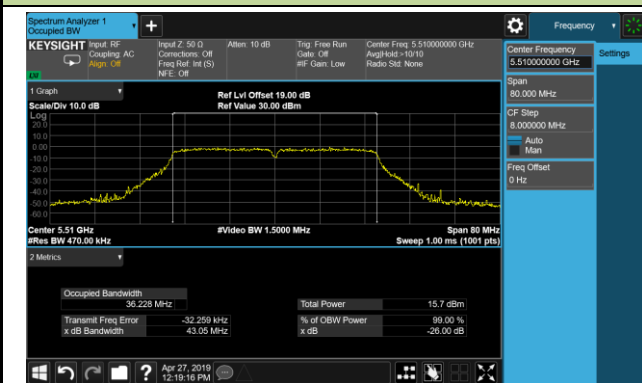

Channel 110 (5500MHz)



802.11n-HT40 26dB Bandwidth & 99% Bandwidth

Channel 118 (5590MHz)



Channel 134 (5670MHz)

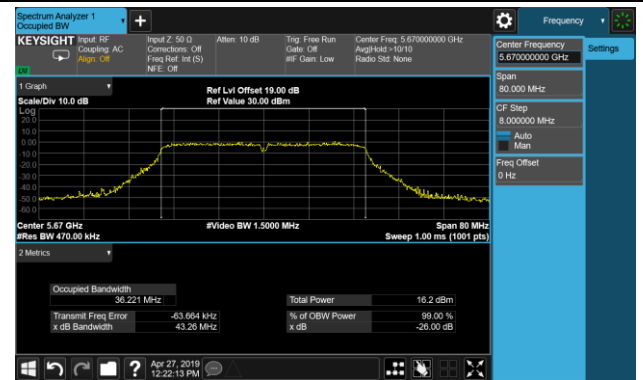

Channel 151 (5755MHz)



Channel 159 (5795MHz)

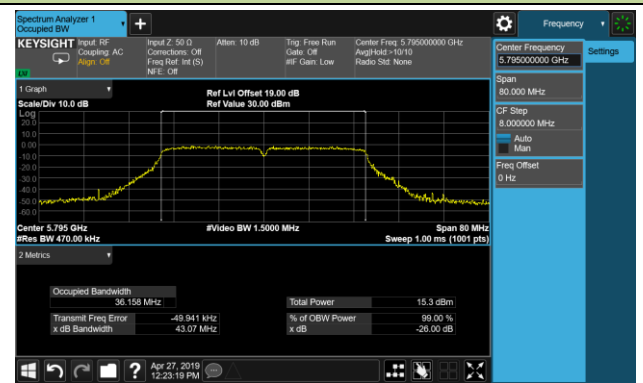

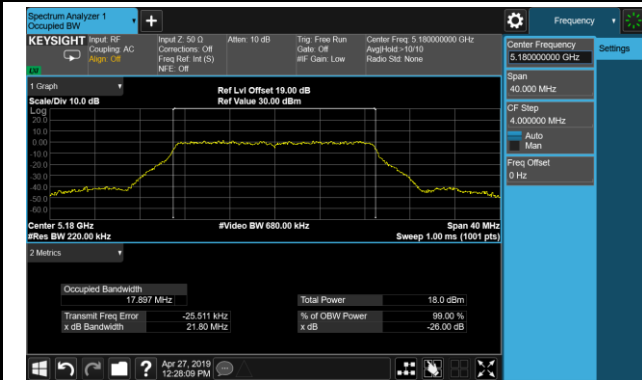
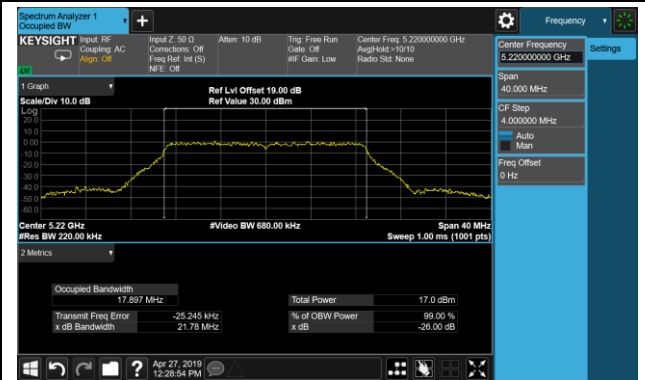
802.11ac-VHT20 26dB Bandwidth & 99% Bandwidth
Channel 36 (5180MHz)

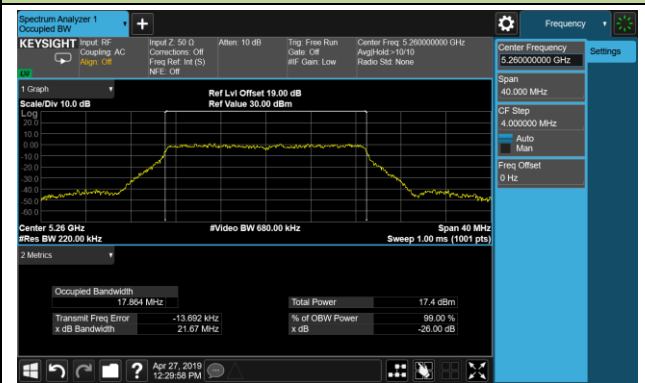
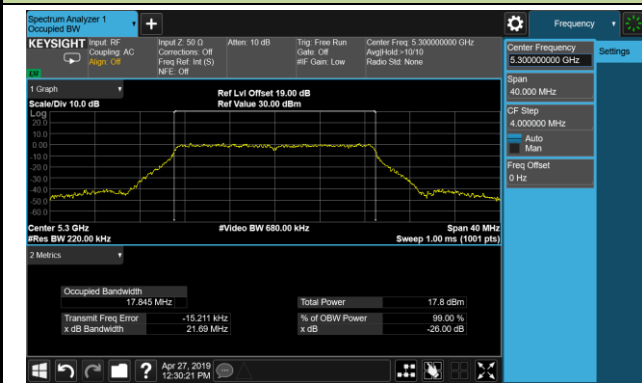
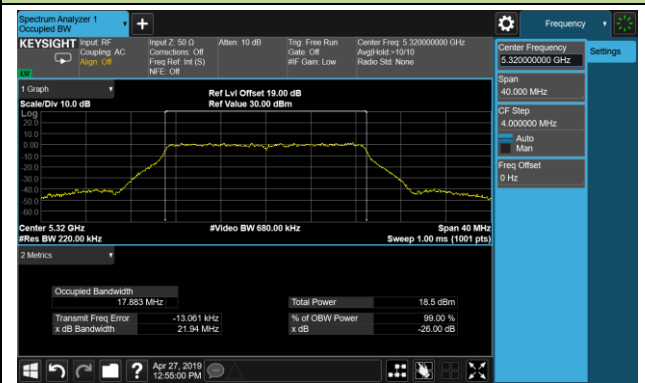
Channel 44 (5220MHz)

Channel 48 (5240MHz)

Channel 52 (5260MHz)

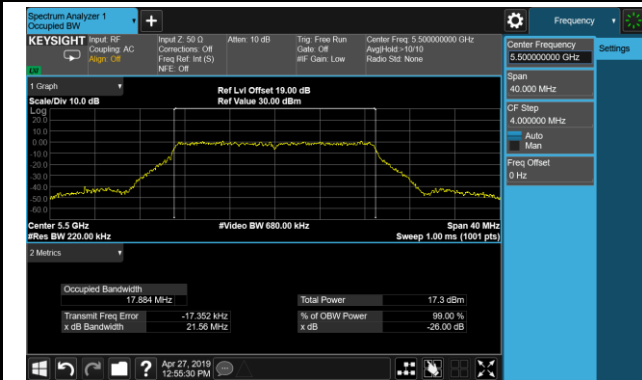
Channel 60 (5300MHz)

Channel 64 (5320MHz)

802.11ac-VHT20 26dB Bandwidth & 99% Bandwidth

Channel 100 (5500MHz)

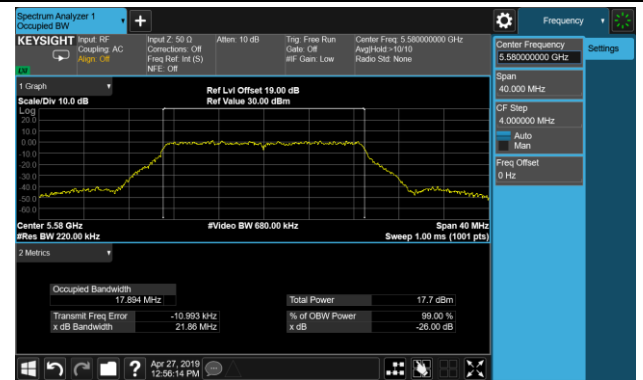

Channel 116 (5580MHz)



Channel 120 (5600MHz)

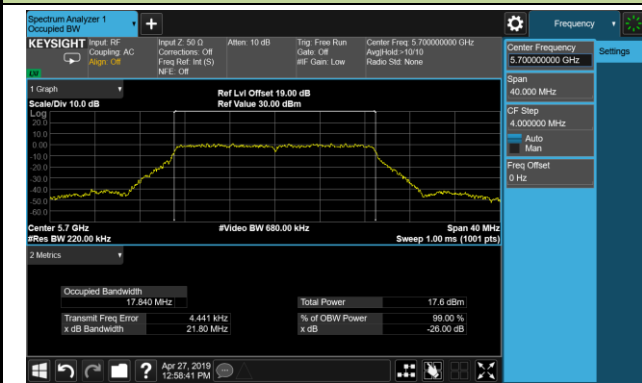

Channel 140 (5700MHz)

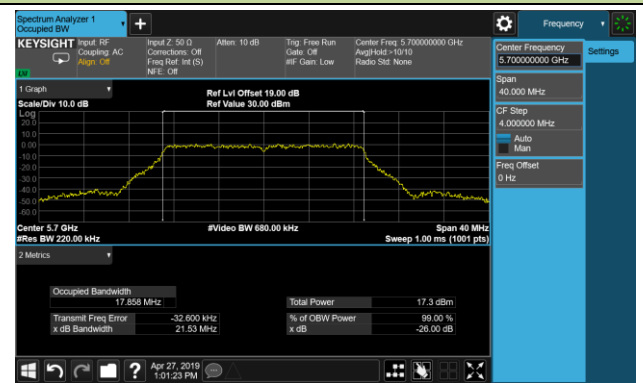

Channel 149 (5745MHz)

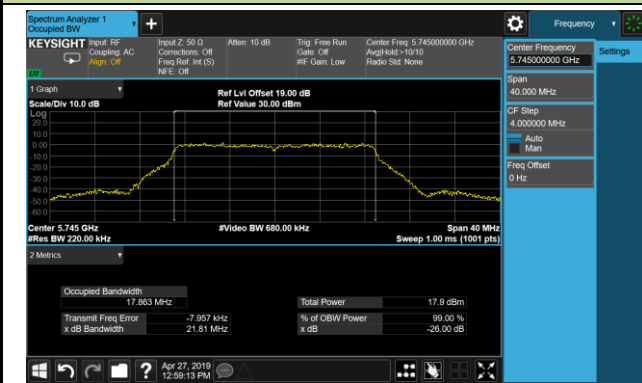

Channel 157 (5785MHz)

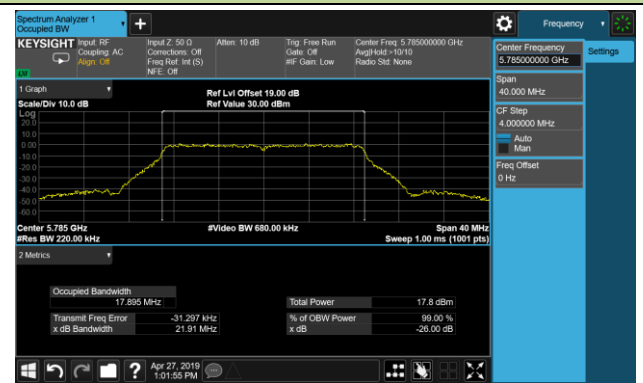

802.11ac-VHT20 26dB Bandwidth & 99% Bandwidth

Channel 165 (5825MHz)



802.11ac-VHT40 26dB Bandwidth & 99% Bandwidth

Channel 38 (5190MHz)

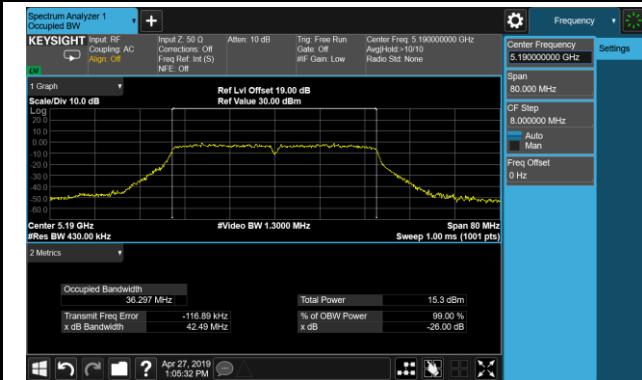

Channel 46 (5230MHz)

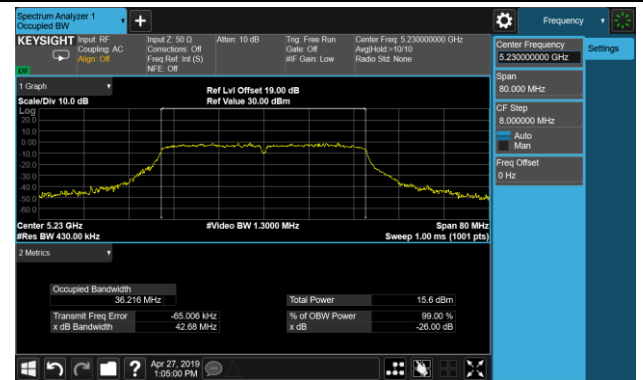

Channel 54 (5270MHz)

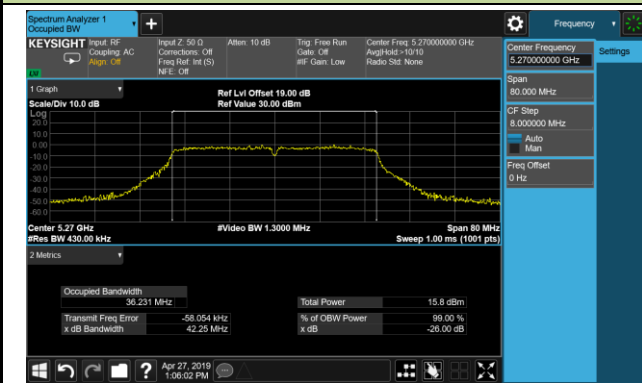

Channel 62 (5310MHz)

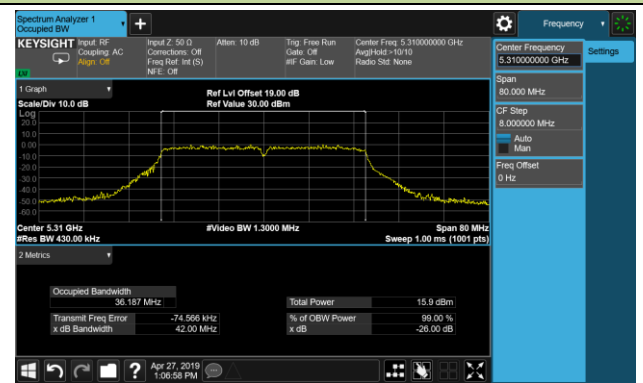

Channel 102 (5510MHz)

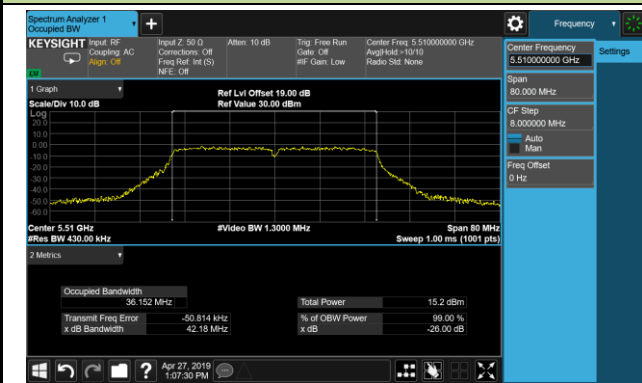

Channel 110 (5550MHz)

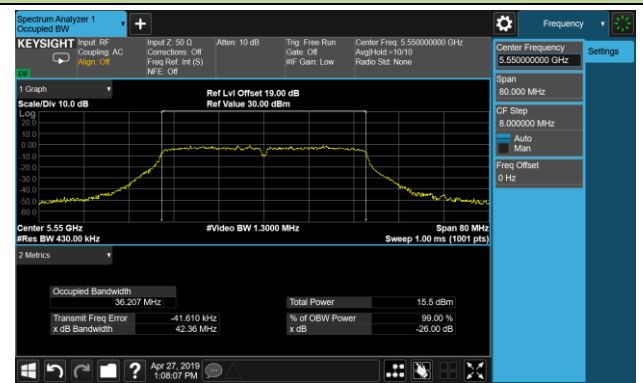

802.11ac-VHT40 26dB Bandwidth & 99% Bandwidth

Channel 118 (5590MHz)



Channel 134 (5670MHz)

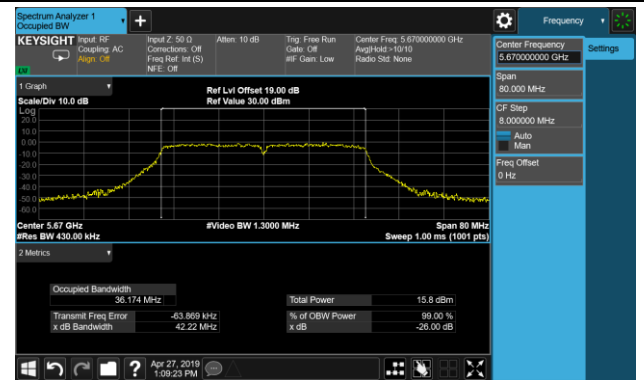

Channel 151 (5755MHz)

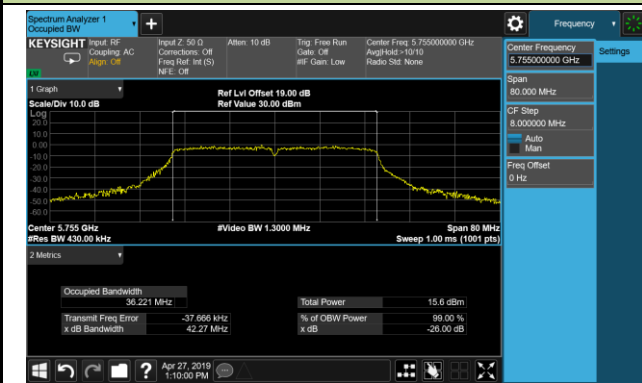

Channel 159 (5795MHz)

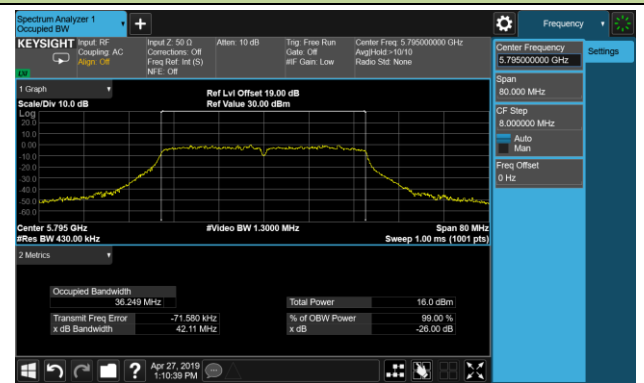

802.11ac-VHT80 26dB Bandwidth & 99% Bandwidth

Channel 42 (5210MHz)

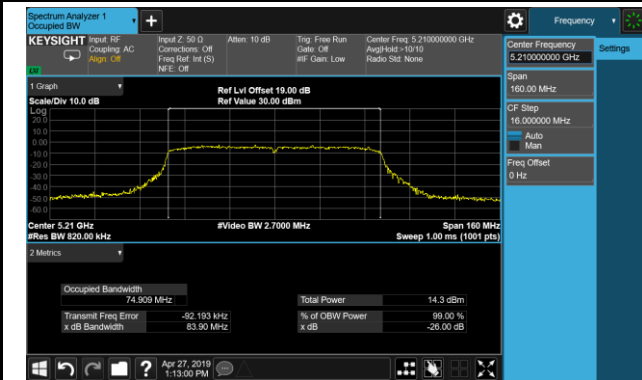

Channel 58 (5290MHz)

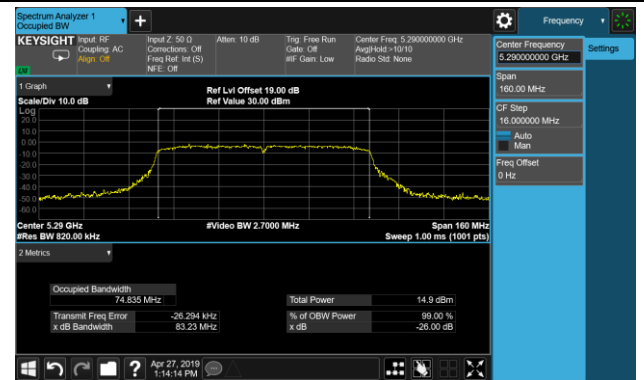

Channel 106 (5530MHz)



Channel 122 (5610MHz)

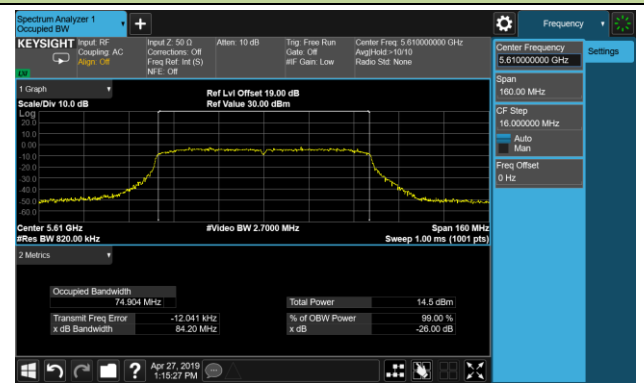

Channel 155 (5775MHz)

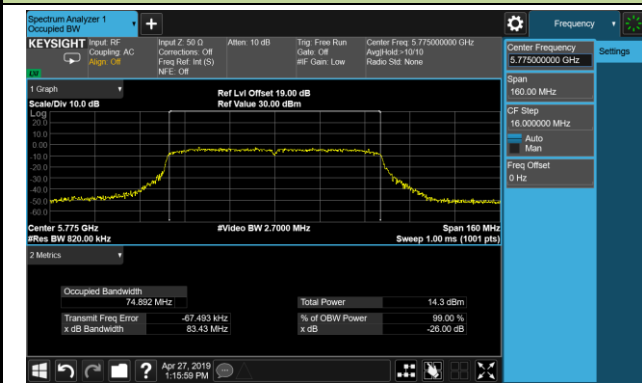

7.3. 6dB Bandwidth Measurement

7.3.1. Test Limit

The minimum 6dB bandwidth shall be at least 500 kHz.

7.3.2. Test Procedure Used

ANSI C63.10-2013 - Section 6.9.2

7.3.3. Test Setting

1. Set center frequency to the nominal EUT channel center frequency.
2. RBW = 100 kHz.
3. VBW $\geq 3 \times$ RBW.
4. Detector = Peak.
5. Trace mode = Max hold.
6. Sweep = Auto couple.
7. Allow the trace to stabilize.
8. Measure the maximum width of the emission that is constrained by the frequencies associated with the two outermost amplitude points (upper and lower frequencies) that are attenuated by 6 dB relative to the maximum level measured in the fundamental emission.

7.3.4. Test Setup

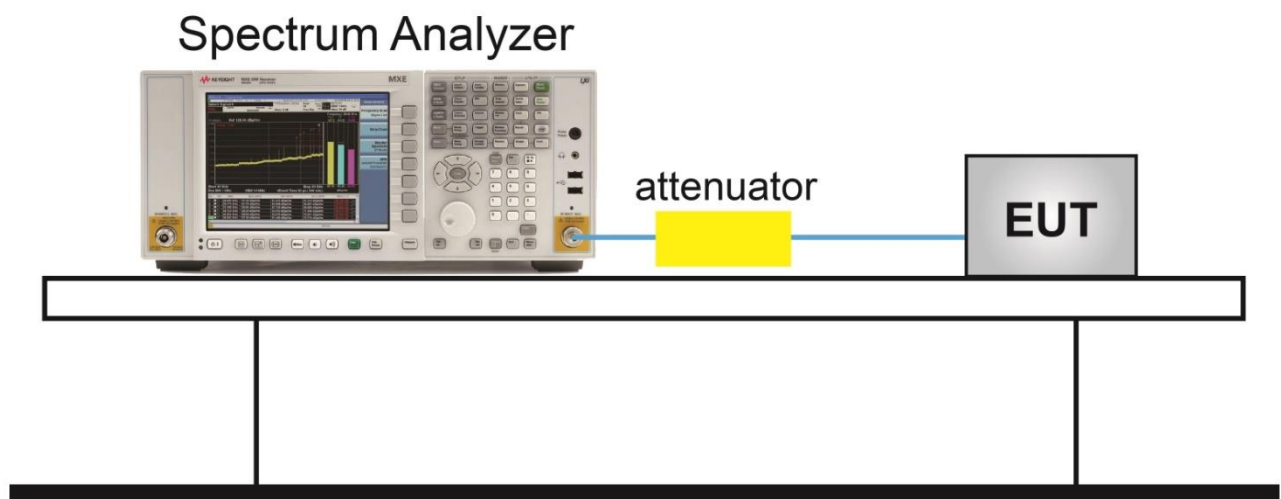

7.3.5.TestResult

Product	Tablet	Temperature	25°C
Test Engineer	Flag Yang	Relative Humidity	52%
Test Site	TR3	Test Date	2019/04/27

Test Mode	Data Rate/ MCS	Channel No.	Frequency (MHz)	6dB Bandwidth (MHz)	Limit (MHz)	Result
802.11a	6Mbps	149	5745	16.43	≥0.5	Pass
802.11a	6Mbps	157	5785	16.42	≥0.5	Pass
802.11a	6Mbps	165	5825	16.44	≥0.5	Pass
802.11n-HT20	MCS0	149	5745	17.64	≥0.5	Pass
802.11n-HT20	MCS0	157	5785	17.66	≥0.5	Pass
802.11n-HT20	MCS0	165	5825	17.64	≥0.5	Pass
802.11n-HT40	MCS0	151	5755	35.28	≥0.5	Pass
802.11n-HT40	MCS0	159	5795	35.49	≥0.5	Pass
802.11ac-VHT20	MCS0	149	5745	17.64	≥0.5	Pass
802.11ac-VHT20	MCS0	157	5785	17.64	≥0.5	Pass
802.11ac-VHT20	MCS0	165	5825	17.63	≥0.5	Pass
802.11ac-VHT40	MCS0	151	5755	35.33	≥0.5	Pass
802.11ac-VHT40	MCS0	159	5795	35.33	≥0.5	Pass
802.11ac-VHT80	MCS0	155	5775	75.30	≥0.5	Pass

802.11a 6dB Bandwidth

Channel 149 (5745MHz)

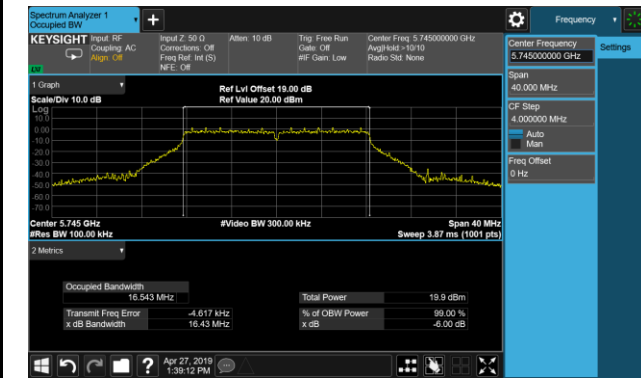

Channel 157 (5785MHz)

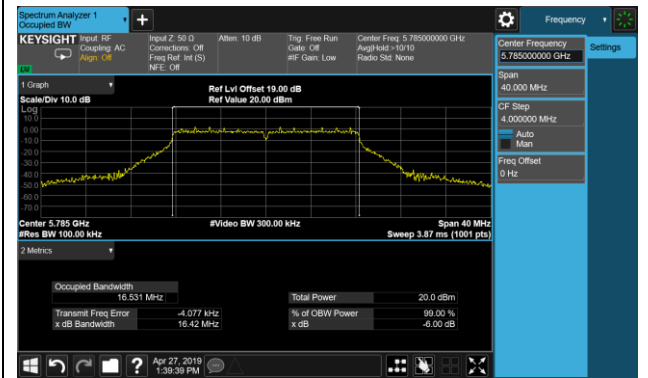

Channel 165 (5825MHz)

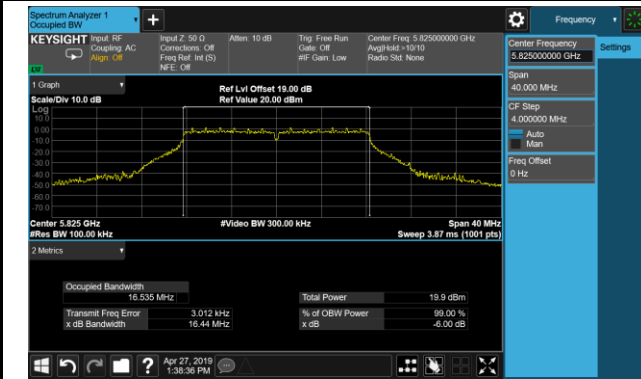

802.11n-HT20 6dB Bandwidth

Channel 149 (5745MHz)

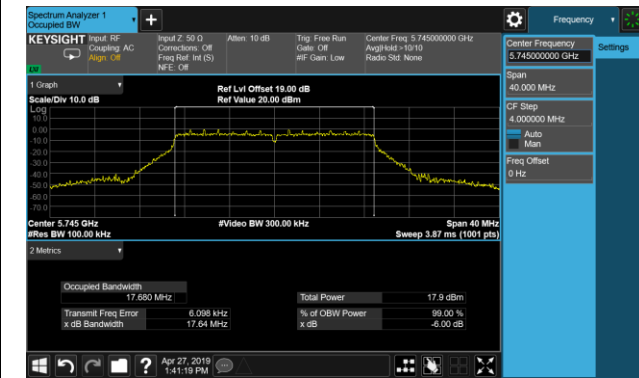

Channel 157 (5785MHz)

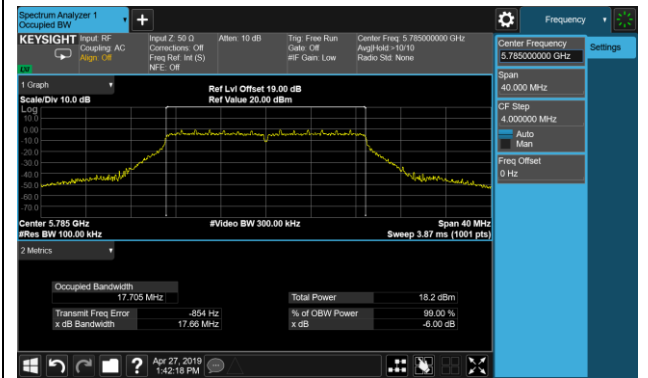

Channel 165 (5825MHz)

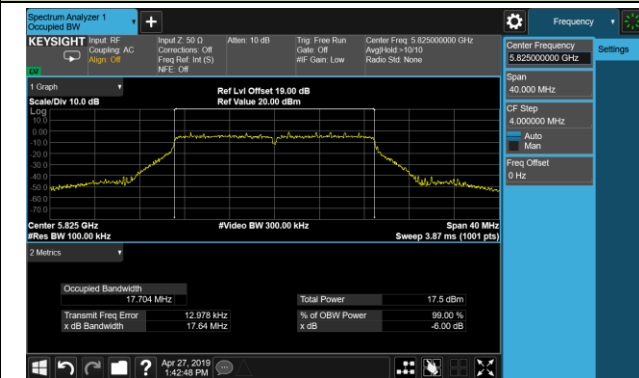

802.11n-HT40 6dB Bandwidth

Channel 151 (5755MHz)

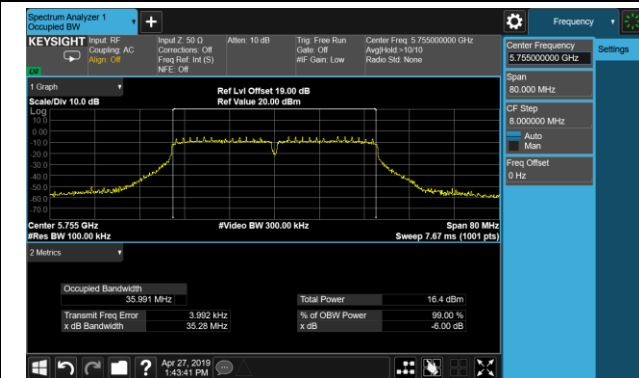

Channel 159 (5795MHz)

