

RF MEASUREMENT REPORT

FCC ID: HD5-EDA5S1

Applicant: Honeywell International Inc
Honeywell Safety and Productivity Solutions

Product: Mobile Computer

Model No.: EDA5S-1

Brand Name: Honeywell

FCC Classification: Part 15 Low Power Communication Device Transmitter (DXX)

FCC Rule Part(s): Part 15 Subpart C (Section 15.225)

Test Procedure(s): ANSI C63.10-2013

Test Date: December 30 ~ 31, 2021

Reviewed By:

Jame Yuan

Approved By:

Robin Wu



The test results relate only to the samples tested.

This equipment has been shown to be capable of compliance with the applicable technical standards as indicated in the measurement report and was tested in accordance with the measurement procedures specified in ANSI C63.10-2013. Test results reported herein relate only to the item(s) tested.

The test report shall not be reproduced except in full without the written approval of MRT Technology (Suzhou) Co., Ltd.

Revision History

Report No.	Version	Description	Issue Date	Note
2111RSU064-U6	Rev. 01	Initial Report	01-06-2022	Valid

CONTENTS

Description	Page
1. General Information.....	5
1.1. Applicant.....	5
1.2. Manufacturer	5
1.3. Testing Facility	5
1.4. Product Information	6
1.5. Radio Specification	6
1.6. Test Mode	6
1.7. Test Configuration and Software.....	7
1.8. EMI Suppression Device(s)/Modifications	7
1.9. Test Environment Condition.....	7
2. Antenna Requirements.....	8
3. Measuring Instrument	9
4. Measurement Uncertainty	10
5. Test Result.....	11
5.1. Summary	11
5.2. In-band Emission.....	12
5.2.1. Test Limit	12
5.2.2. Test Procedure.....	12
5.2.3. Test Setting.....	12
5.2.4. Test Setup.....	13
5.2.5. Test Result.....	13
5.3. Out-band Emission	14
5.3.1. Test Limit	14
5.3.2. Test Procedure.....	14
5.3.3. Test Setting.....	14
5.3.4. Test Setup.....	15
5.3.5. Test Result.....	15
5.4. Occupied Bandwidth.....	16
5.4.1. Test Limit	16
5.4.2. Test Procedure.....	16
5.4.3. Test Setting.....	16
5.4.4. Test Setup.....	16
5.4.5. Test Result.....	17
5.5. Frequency Tolerance.....	18
5.5.1. Test Limit	18

5.5.2.	Test Procedure.....	18
5.5.3.	Test Setting.....	18
5.5.4.	Test Setup.....	19
5.5.5.	Test Result.....	19
5.6.	AC Conducted Emissions Measurement.....	20
5.6.1.	Test Limit	20
5.6.2.	Test Setup.....	20
5.6.3.	Test Result.....	20
Appendix A - Test Result		21
A.1	<i>In-band Emission Test Result.....</i>	21
A.2	<i>Out-Band Emission Test Result.....</i>	22
A.3	<i>Occupied Bandwidth Test Result.....</i>	23
A.4	<i>Frequency Stability Tolerance Test Result.....</i>	24
A.5	<i>AC Conducted Emissions Test Result.....</i>	25
Appendix B - Test Setup Photograph		28
Appendix C - EUT Photograph.....		29

1.4. Product Information

Product Name	Mobile Computer
Model No.	EDA5S-1
Serial Number	21294B3F94
Wi-Fi Specification	802.11a/b/g/n/ac
Bluetooth Specification	v5.0 dual mode
NFC Specification	Active, 13.56MHz
GNSS Specification	GPS/Galileo/BDS/GLONASS
3GPP Specification	GSM 850/1900 WCDMA Band 2/4/5 LTE Band 2/4/5/7/12/13/17/25/26/30/38/40/41/66
Working Voltage	3.85Vdc
Accessories	
Adapter	Model No.: ADS-12B-06 05010E Input Power: 100 - 240V ~ 50/60Hz, Max. 0.3A Output Power: 5VDC 2.0A
Rechargeable Li-ion Battery	Model No.: BAT-EDA5S Capacitance: 3060mAh 11.78Wh Rated Voltage: 3.85V
Remark: The information of EUT was provided by the manufacturer, and the accuracy of the information shall be the responsibility of the manufacturer.	

1.5. Radio Specification

Frequency Range	13.56MHz
Channel Number	1
Type of modulation	ASK
Antenna Type	Loop Antenna

Note: For other features of this EUT, test report will be issued separately.

1.6. Test Mode

Mode 1: Transmit by NFC

1.7. Test Configuration and Software

The device was tested per the guidance ANSI C63.10-2013 that was used to reference the appropriate EUT setup for radiated spurious emissions and AC line conducted emission testing.

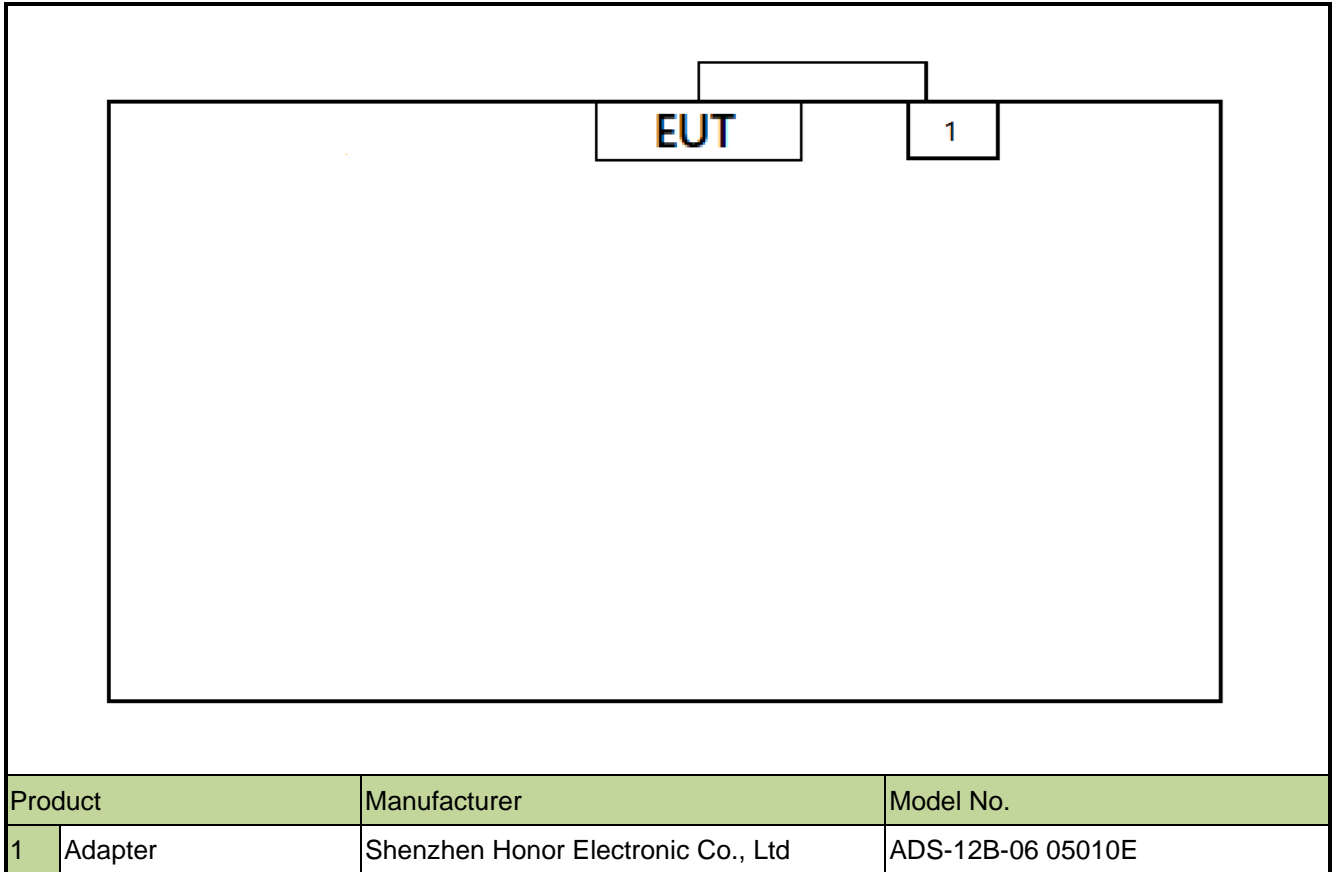

1.8. EMI Suppression Device(s)/Modifications

No EMI suppression device(s) were added and/or no modifications were made during testing.

1.9. Test Environment Condition

Ambient Temperature	15 ~ 35 °C
Relative Humidity	20 ~75 %RH

2. Antenna Requirements

Excerpt from §15.203 of the FCC Rules/Regulations:

“An intentional radiator antenna shall be designed to ensure that no antenna other than that furnished by the responsible party can be used with the device. The use of a permanently attached antenna or of an antenna that uses a unique coupling to the intentional radiator shall be considered sufficient to comply with the provisions of this section.”

- The antenna of the **Mobile Computer** is **permanently attached**.
- There are no provisions for connection to an external antenna.

Conclusion:

The unit complies with the requirement of §15.203.

3. Measuring Instrument

Instrument Name	Manufacturer	Model No.	Asset No.	Cali. Interval	Cal. Due Date	Test Site
Horn Antenna	Schwarzbeck	BBHA 9170	MRTSUE06599	1 year	2022/10/20	SIP-AC2
Preamplifier	EMCI	EMC184045SE	MRTSUE06602	1 year	2022/10/11	SIP-AC2
Thermohygrometer	testo	608-H1	MRTSUE06623	1 year	2022/11/28	SIP-AC2
Thermohygrometer	testo	608-H1	MRTSUE06624	1 year	2022/11/28	SIP-AC2
Preamplifier	EMCI	EMC051845SE	MRTSUE06644	1 year	2022/11/8	SIP-AC2
TRILOG Antenna	Schwarzbeck	VULB 9168	MRTSUE06647	1 year	2022/8/5	SIP-AC2
Loop Antenna	Schwarzbeck	FMZB 1519 B	MRTSUE06937	1 year	2022/3/9	SIP-AC2
Anechoic Chamber	RIKEN	SIP-AC2	MRTSUE06781	1 year	2022/12/23	SIP-AC2
Horn Antenna	Schwarzbeck	BBHA 9120D	MRTSUE06648	1 year	2022/11/9	SIP-AC2/SIP-AC4
Two-Line V-Network	R&S	ENV216	MRTSUE06002	1 year	2022/6/8	WZ-SR2
Absorbing Clamp	R&S	MDS-21	MRTSUE06008	1 year	2022/11/30	WZ-SR2
Passive Voltage Probe	R&S	ESH2-Z3	MRTSUE06189	1 year	2022/4/13	WZ-SR2
Triple-Loop Antenna	R&S	HM020	MRTSUE06191	3 year	2024/4/13	WZ-SR2
Shielding Room	MIX-BEP	WZ-SR2	MRTSUE06215	/	/	WZ-SR2
Thermohygrometer	testo	608-H1	MRTSUE06404	1 year	2022/6/28	WZ-SR2
Current Probe	FCC	F-52	MRTSUE06494	1 year	2022/5/6	WZ-SR2
Four-Line V-Network	R&S	ENV432	MRTSUE06615	1 year	2022/10/10	WZ-SR2
EMI Test Receiver	R&S	ESR3	MRTSUE06909	1 year	2022/11/1	WZ-SR2

Software	Version	Function
EMI Software	V3	EMI Test Software

4. Measurement Uncertainty

Where relevant, the following test uncertainty levels have been estimated for tests performed on the EUT as specified in CISPR 16-4-2. This uncertainty represents an expanded uncertainty expressed at approximately the 95% confidence level using a coverage factor of $k = 2$.

AC Conducted Emission Measurement
Measurement Uncertainty for a Level of Confidence of 95% ($U=2Uc(y)$): 9kHz~150kHz: 3.74dB 150kHz~30MHz: 3.44dB
Radiated Disturbance
Measurement Uncertainty for a Level of Confidence of 95% ($U=2Uc(y)$): Horizontal: 9kHz~300MHz: 5.04dB 300MHz~1GHz: 4.95dB 1GHz~40GHz: 6.40dB Vertical: 9kHz~300MHz: 5.24dB 300MHz~1GHz: 6.03dB 1GHz~40GHz: 6.40dB
Occupied Bandwidth
Measuring Uncertainty for a Level of Confidence of 95% ($U=2Uc(y)$): 0.28%

5. Test Result

5.1. Summary

FCC Part Section(s)	Test Description	Test Condition	Test Result	Reference
15.225 (a), (b), (c)	In-Band Emission	Radiated	Pass	Section 5.2
15.225(d)	Out-Band Emission		Pass	Section 5.3
2.1049	20dB Bandwidth 99% Bandwidth		Pass	Section 5.4
15.225(e)	Frequency Stability Tolerance		Pass	Section 5.5
15.207	AC Conducted Emissions 150kHz - 30MHz	Line Conducted	Pass	Section 5.6

Notes:

- 1) All modes of operation and data rates were investigated. For radiated emission test, every axis (X, Y, Z) was also verified. The test results shown in the following sections represent the worst case emissions.
- 2) The analyzer plots shown in this section were all taken with a correction table loaded into the analyzer. The correction table was used to account for the losses of the cables and attenuators used as part of the system to connect the EUT to the analyzer at all frequencies of interest.

5.2. In-band Emission

5.2.1. Test Limit

FCC Part 15 Subpart C Paragraph 15.225		
Frequency (MHz)	Distance (m)	Level (μ V/m)
13.553 ~13.567	30	15848
13.410 ~13.553, 13.567 ~13.710	30	334
13.110 ~13.410, 13.710 ~14.010	30	106

Note 1: The lower limit shall apply at the transition frequency.

Note 2: Distance refers to the distance in meters between the measuring instrument antenna and the closed point of any part of the device or system.

Note 3: E field strength (dB μ V/m) = 20 log E field strength (μ V/m)

5.2.2. Test Procedure

ANSI C63.10-2013 - Section 6.4.7

5.2.3. Test Setting

1. RBW = 9kHz
2. VBW = 3 * RBW
3. Detector = Peak
4. Trace mode = Max hold
5. Sweep = Auto couple
6. Allow the trace to stabilize

5.2.4. Test Setup

9kHz ~ 30MHz Test Setup:

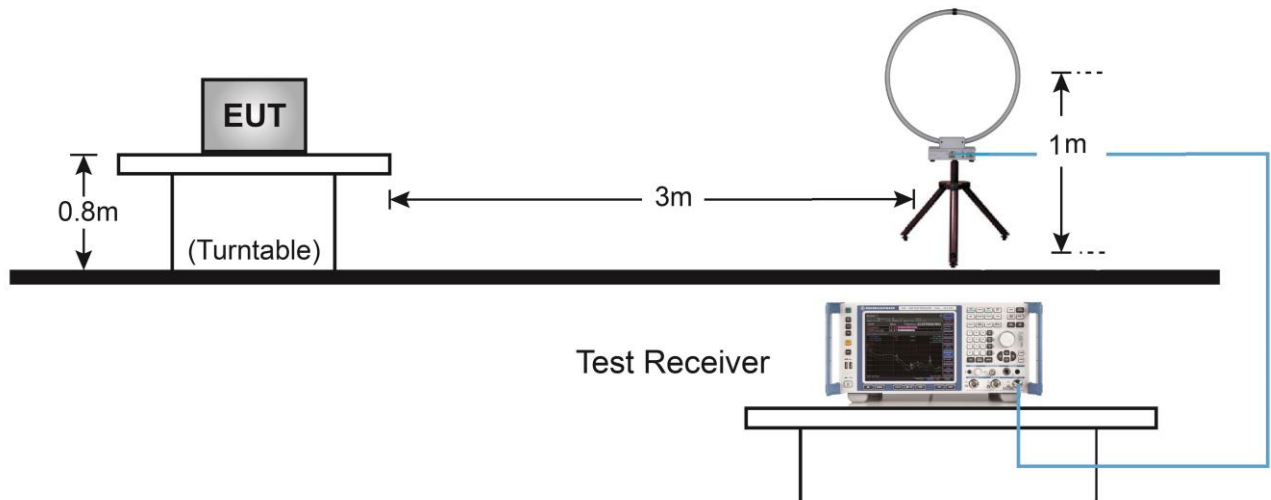

5.2.5. Test Result

Refer to Appendix A.1.

5.3. Out-band Emission

5.3.1. Test Limit

FCC Part 15 Subpart C Paragraph 15.209		
Frequency (MHz)	Distance (m)	Level ($\mu\text{V/m}$)
0.009 - 0.490	300	2400/F (kHz)
0.490 - 1.705	30	24000/F (kHz)
1.705 - 30	30	30
30 - 88	3	100
88 - 216	3	150
216 - 960	3	200
Above 960	3	500

Note 1: The lower limit shall apply at the transition frequency.

Note 2: Distance refers to the distance in meters between the measuring instrument antenna and the closed point of any part of the device or system.

Note 3: E field strength ($\text{dB}\mu\text{V/m}$) = $20 \log$ E field strength ($\mu\text{V/m}$)

5.3.2. Test Procedure

ANSI C63.10-2013 - Section 6.5.4

5.3.3. Test Setting

1. Analyzer center frequency was set to the frequency of the radiated spurious emission of interest
2. RBW = 9kHz for emission below 30MHz and 100kHz for emission between 30MHz and 1GHz
3. VBW = 3 * RBW
4. Detector = Peak
5. Trace mode = Max hold
6. Sweep = Auto couple
7. Allow the trace to stabilize

5.3.4. Test Setup

9kHz ~ 30MHz Test Setup:

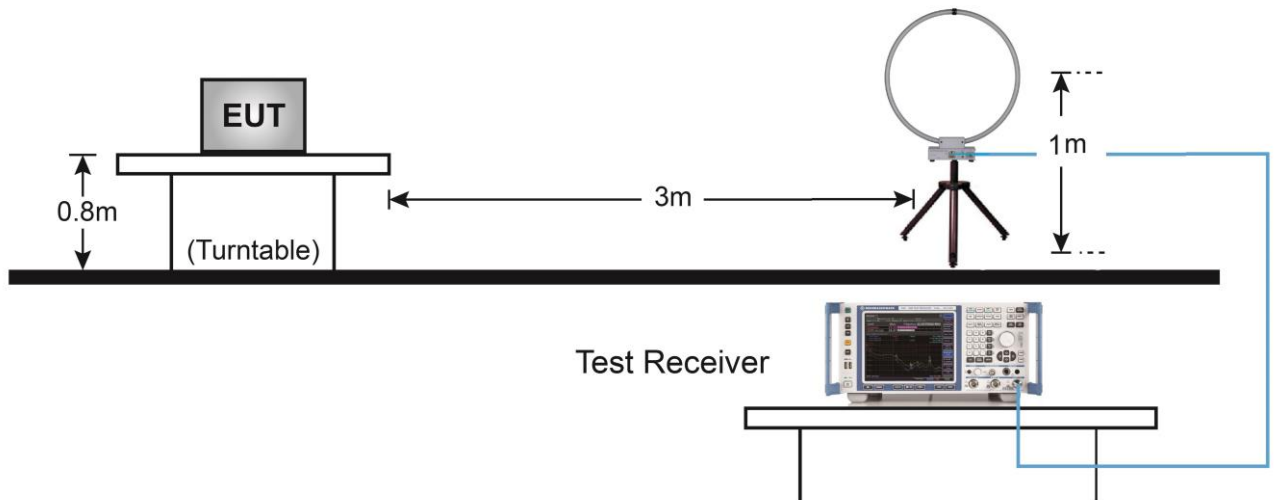

30MHz ~ 1GHz Test Setup:

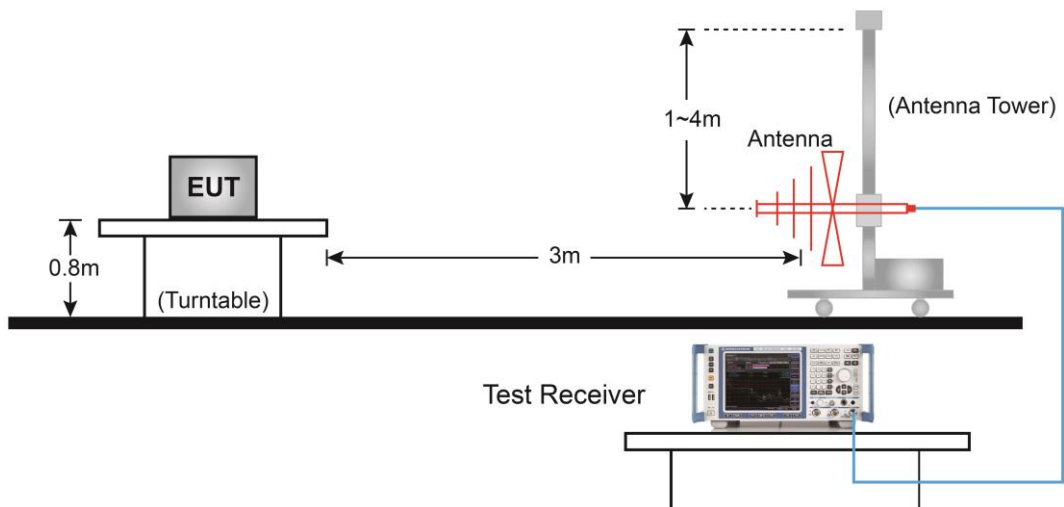

5.3.5. Test Result

Refer to Appendix A.2.

5.4. Occupied Bandwidth

5.4.1. Test Limit

The occupied bandwidth is measured with a spectrum analyzer connected to the receive antenna while the EUT is operating in transmission mode at the appropriate frequency.

5.4.2. Test Procedure

ANSI C63.10-2013 - Section 6.9.3

5.4.3. Test Setting

1. Spectrum analyzer frequency is set to the nominal EUT channel center frequency.
2. Set RBW \geq 1% to 5% of the OBW
3. VBW = Approximately three times RBW
4. Reference level set to keep signal from exceeding maximum input mixer level for linear operation
5. Detector = Peak
6. Trace mode = Max hold
7. Sweep = Auto couple
8. Allow the trace to stabilize
9. Using 99% power bandwidth function of the instrument and report the measured bandwidth

5.4.4. Test Setup

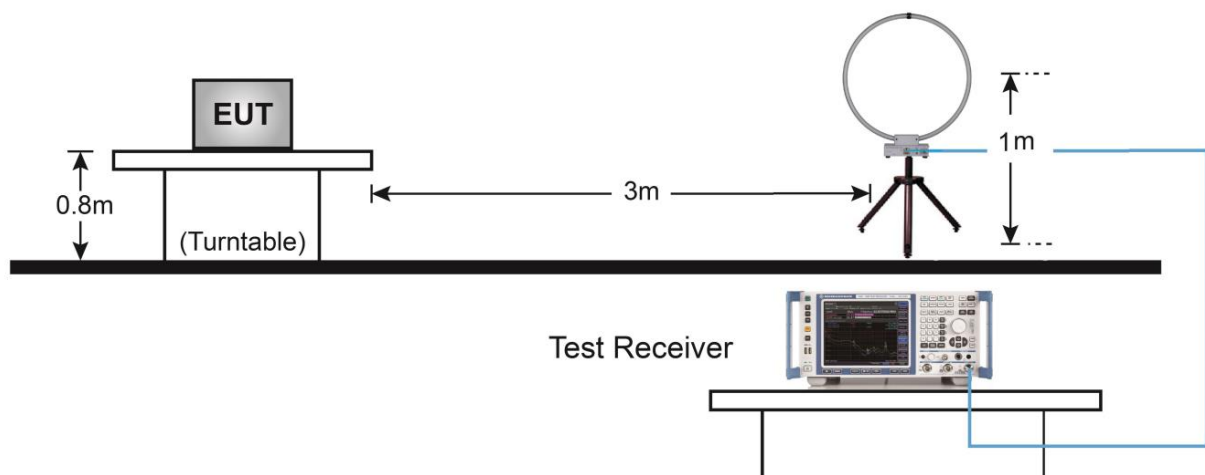

5.4.5. Test Result

Refer to Appendix A.3.

5.5. Frequency Tolerance

5.5.1. Test Limit

The frequency tolerance of the carrier signal shall be maintained within +/- 0.01% of the operating frequency.

5.5.2. Test Procedure

ANSI C63.10-2013 - Section 6.8

5.5.3. Test Setting

Frequency Stability Under Temperature Variations:

The equipment under test was connected to an external AC or DC power supply and input rated voltage. RF output was connected to a frequency counter or spectrum analyzer via feed through attenuators. The EUT was placed inside the temperature chamber. Set the spectrum analyzer RBW low enough to obtain the desired frequency resolution and measure EUT 20°C operating frequency as reference frequency. Turn EUT off and set the chamber temperature to highest. After the temperature stabilized for approximately 30 minutes recorded the frequency. Repeat step measure with 10°C decreased per stage until the lowest temperature reached.

Frequency Stability Under Voltage Variations:

Set chamber temperature to 20°C. Use a variable AC power supply / DC power source to power the EUT and set the voltage to rated voltage. Set the spectrum analyzer RBW low enough to obtain the desired frequency resolution and recorded the frequency.

Reduce the input voltage to specify extreme voltage variation ($\pm 15\%$) and endpoint, record the maximum frequency change. For hand-carried battery-powered equipment, primary supply voltage is reduced to the battery operating end point which shall be specified by the manufacturer.

5.5.4. Test Setup

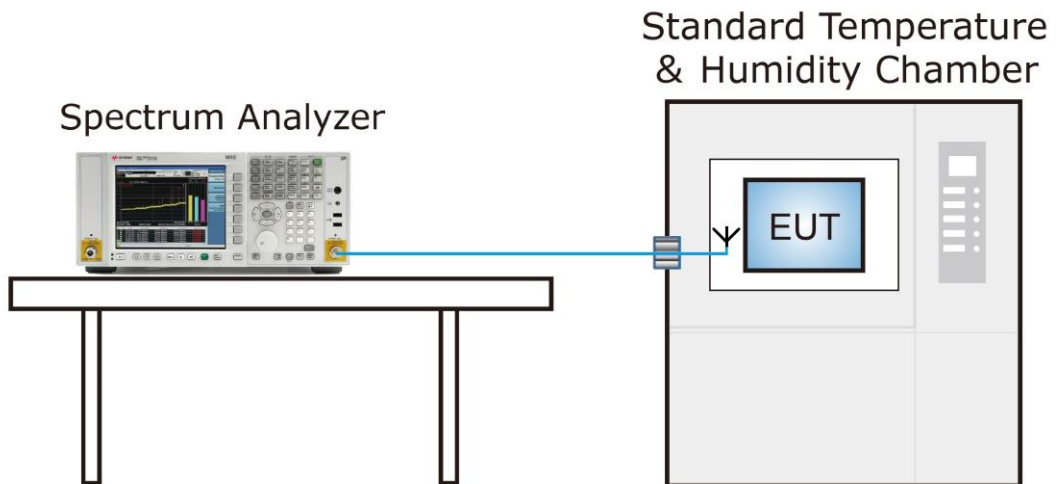

5.5.5. Test Result

Refer to Appendix A.4.

5.6. AC Conducted Emissions Measurement

5.6.1. Test Limit

FCC Part 15 Subpart C Paragraph 15.207		
Frequency (MHz)	QP (dB μ V)	AV (dB μ V)
0.15 - 0.50	66 - 56	56 - 46
0.50 - 5.0	56	46
5.0 - 30	60	50

Note 1: The lower limit shall apply at the transition frequencies.

Note 2: The limit decreases linearly with the logarithm of the frequency in the range 0.15MHz to 0.5MHz.

5.6.2. Test Setup

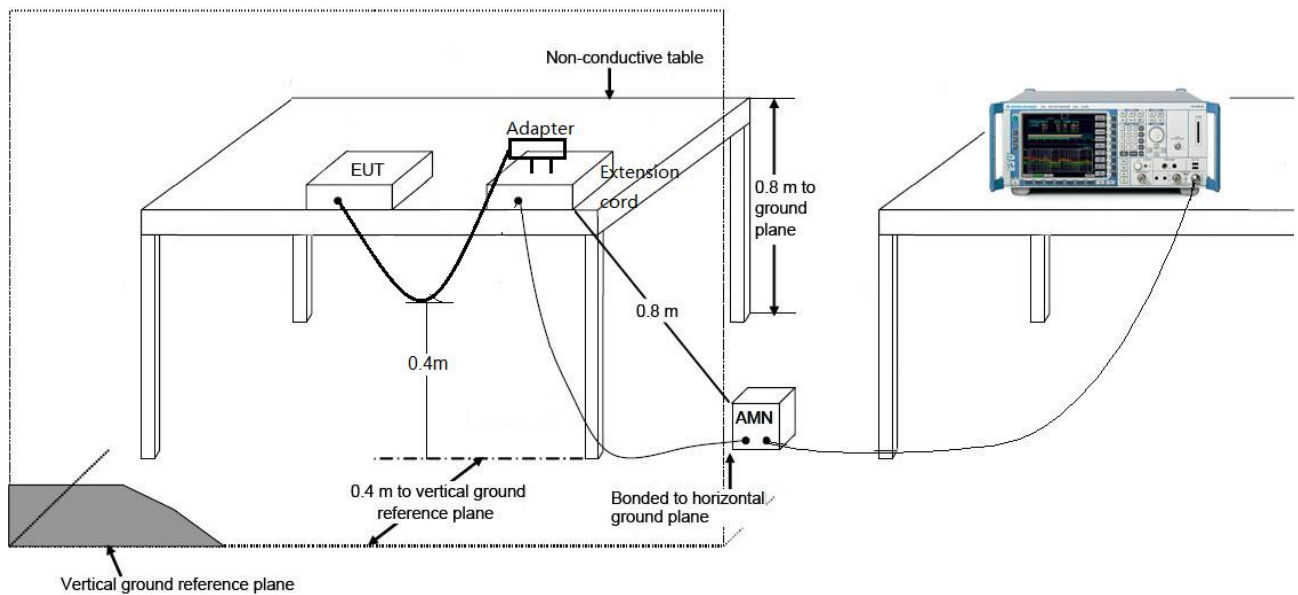

5.6.3. Test Result

Refer to Appendix A.5.

Appendix A - Test Result

A.1 In-band Emission Test Result

Test Engineer	Stephen Dong	Test Date	2021/12/30
Test Mode	Mode1	Test Site	SIP-AC2

Frequency (MHz)	Reading Level (dB μ V/m)	Factor (dB)	Measure Level (dB μ V/m)	Limit (@3m) (dB μ V/m)	Margin [dB]
Face On					
13.35	9.23	19.85	29.08	80.51	-51.43
13.55	15.95	19.71	35.66	90.47	-54.81
13.56	26.25	19.72	45.97	123.99	-78.02
13.57	15.92	19.73	35.65	90.47	-54.82
13.77	8.87	19.88	28.75	80.51	-51.76
Face Off					
13.35	5.37	19.85	25.22	80.51	-55.29
13.55	12.77	19.71	32.48	90.47	-57.99
13.56	22.97	19.72	42.69	123.99	-81.30
13.57	12.66	19.73	32.39	90.47	-58.08
13.77	4.82	19.88	24.70	80.51	-55.81

Note 1: All measurements were performed using a loop antenna. The antenna was positioned in two orthogonal (face on and face off) and the position with the highest emission level was recorded.

Note 2: Measurements were tested at 3m and the data was extrapolated to the specified measurement distance of 30m using the square of an inverse linear extrapolation factor (40 dB/decade) as specified in &15.31(f)(2).

Extrapolation Factor = $40 * \log(30/3) = 40$ dB

For example, Limit (@3m) = $20 * \log(106) + 40 = 80.51$ dB μ V/m

Note 3: All measurements were recorded using an EMI test receiver employing a peak detector.

A.2 Out-Band Emission Test Result

Test Engineer	Stephen Dong	Test Date	2021/12/30
Test Mode	Mode1	Test Site	SIP-AC2

Out-Band Emission Below 30MHz						
Frequency (MHz)	Reading Level (dB μ V/m)	Factor (dB)	Measure Level (dB μ V/m)	Limit(@3m) (dB μ V/m)	Margin (dB)	Detector
Face On						
27.12	5.24	19.96	25.20	69.54	-44.34	Peak
Face Off						
27.12	5.55	19.96	25.51	69.54	-44.03	Peak

Out-Band Emission Above 30MHz							
Polarization	Frequency (MHz)	Reading Level (dB μ V/m)	Factor (dB)	Measure Level (dB μ V/m)	Limit (dB μ V/m)	Margin (dB)	Detector
H	34.37	1.22	17.54	18.76	40.00	-21.24	Peak
H	42.13	1.51	17.93	19.44	43.50	-24.06	Peak
H	54.25	0.41	18.37	18.78	46.00	-27.22	Peak
H	612.00	1.71	26.77	28.48	46.00	-17.52	Peak
H	714.82	2.81	27.85	30.66	46.00	-15.34	Peak
H	873.42	3.20	29.91	33.11	46.00	-12.89	Peak
V	40.67	7.50	17.97	25.47	40.00	-14.53	Peak
V	338.95	6.54	20.00	26.54	40.00	-13.46	Peak
V	519.37	1.87	24.18	26.05	43.50	-17.45	Peak
V	614.91	1.36	26.78	28.14	46.00	-17.86	Peak
V	754.59	1.85	28.68	30.53	46.00	-15.47	Peak
V	886.03	2.15	29.96	32.11	46.00	-13.89	Peak

Note 1: Below 30MHz measurement was performed using a loop antenna. The antenna was positioned in two orthogonal (face on and face off) and the position with the highest emission level was recorded.

Note 2: Measurements were tested at 3m and the data was extrapolated to the specified measurement distance of 30m using the square of an inverse linear extrapolation factor (40 dB/decade) as specified in &15.31(f)(2). Extrapolation Factor = $40 \cdot \log(30/3) = 40$ dB

For example, Limit (@3m) = $20 \cdot \log(30) + 40 = 69.54$ dB μ V/m

Note 3: All measurements were recorded using an EMI test receiver employing a peak detector.

A.3 Occupied Bandwidth Test Result

Test Engineer	Stephen Dong	Test Date	2021/12/30
Test Mode	Mode1	Test Site	SIP-AC2

Frequency (MHz)	20dB Occupied Bandwidth (kHz)	99% Occupied Bandwidth (kHz)
13.56	2.916	2.610



Note: Because the measured signal is CW adjusting the RBW per C63.10-2013 would not be practical since measured bandwidth will always follow the RBW and the result will be approximately twice the RBW.

A.4 Frequency Stability Tolerance Test Result

Test Engineer	Stephen Dong	Test Date	2021/12/30
Test Mode	Mode1	Test Site	SIP-AC2

Reference Voltage: 3.85Vdc					
Deviation Limit: +/- 0.01% = 1356Hz					
Voltage (%)	Temp (°C)	Frequency Tolerance (%)			
		0 minutes	2 minutes	5 minutes	10 minutes
100	-20	0.000480	0.000482	0.000484	0.000486
	-10	0.000293	0.000308	0.000324	0.000337
	0	0.000150	0.000154	0.000157	0.000159
	+10	-0.000136	-0.000130	-0.000127	-0.000123
	+20	0.000017	0.000016	0.000012	0.000011
	+30	-0.000186	-0.000199	-0.000204	-0.000210
	+40	-0.000335	-0.000340	-0.000342	-0.000343
	+50	-0.000347	-0.000351	-0.000376	-0.000375
115	+ 20	0.000109	0.000098	0.000090	0.000085
85	+ 20	0.000083	0.000079	0.000082	0.000078

Note: Frequency Tolerance (ppm) = {[Measured Frequency (MHz) - Declared Frequency (MHz)] / Declared Frequency (MHz)} *10⁶.

A.5 AC Conducted Emissions Test Result

Site: WZ-SR2	Time: 2021/12/31 - 10:11
Limit: FCC_Part15.107_CE_AC Power_Class B	Engineer: Helen Han
Probe: ENV216_101683_Filter Off_E	Polarity: Line
EUT: Mobile Computer	Power: AC 120V/60Hz
Test Mode: NFC Working	

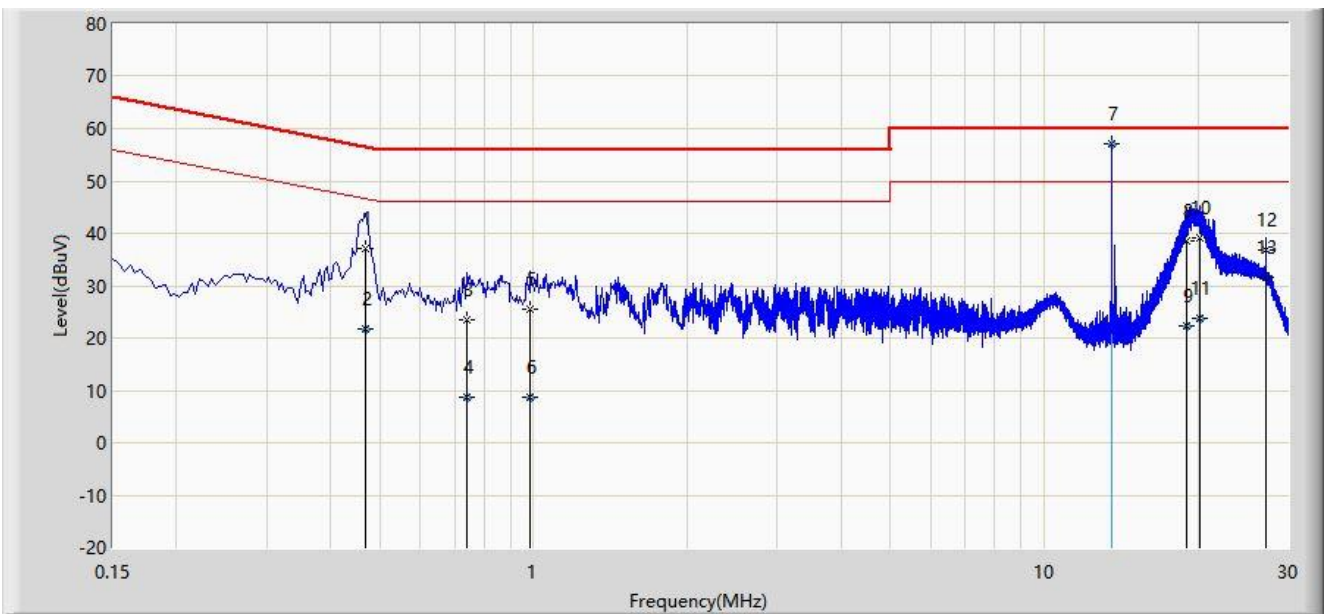

No	Flag	Mark	Frequency (MHz)	Measure Level (dBμV)	Reading Level (dBμV)	Margin (dB)	Limit (dBμV)	Factor (dB)	Type
1			0.470	37.239	27.321	-19.275	56.514	9.918	QP
2			0.470	21.701	11.783	-24.813	46.514	9.918	AV
3			0.738	23.522	13.591	-32.478	56.000	9.930	QP
4			0.738	8.738	-1.192	-37.262	46.000	9.930	AV
5			0.986	25.490	15.541	-30.510	56.000	9.950	QP
6			0.986	8.600	-1.349	-37.400	46.000	9.950	AV
7			13.558	57.005	46.050	N/A	N/A	10.955	PK
8			19.054	38.583	27.202	-21.417	60.000	11.381	QP
9			19.054	22.310	10.929	-27.690	50.000	11.381	AV
10			20.222	39.025	27.539	-20.975	60.000	11.486	QP
11			20.222	23.833	12.347	-26.167	50.000	11.486	AV
12			27.118	36.920	24.977	-23.080	60.000	11.943	QP
13		*	27.118	31.461	19.518	-18.539	50.000	11.943	AV

Note:

- Point 7 is NFC fundamental frequency.
- Measure Level (dBμV) = Reading Level (dBμV) + Factor (dB)

Factor (dB) = Cable Loss (dB) + LISN Factor (dB).

Site: WZ-SR2	Time: 2021/12/31 - 10:16
Limit: FCC_Part15.107_CE_AC Power_Class B	Engineer: Helen Han
Probe: ENV216_101683_Filter Off_E	Polarity: Neutral
EUT: Mobile Computer	Power: AC 120V/60Hz
Test Mode: NFC Working	

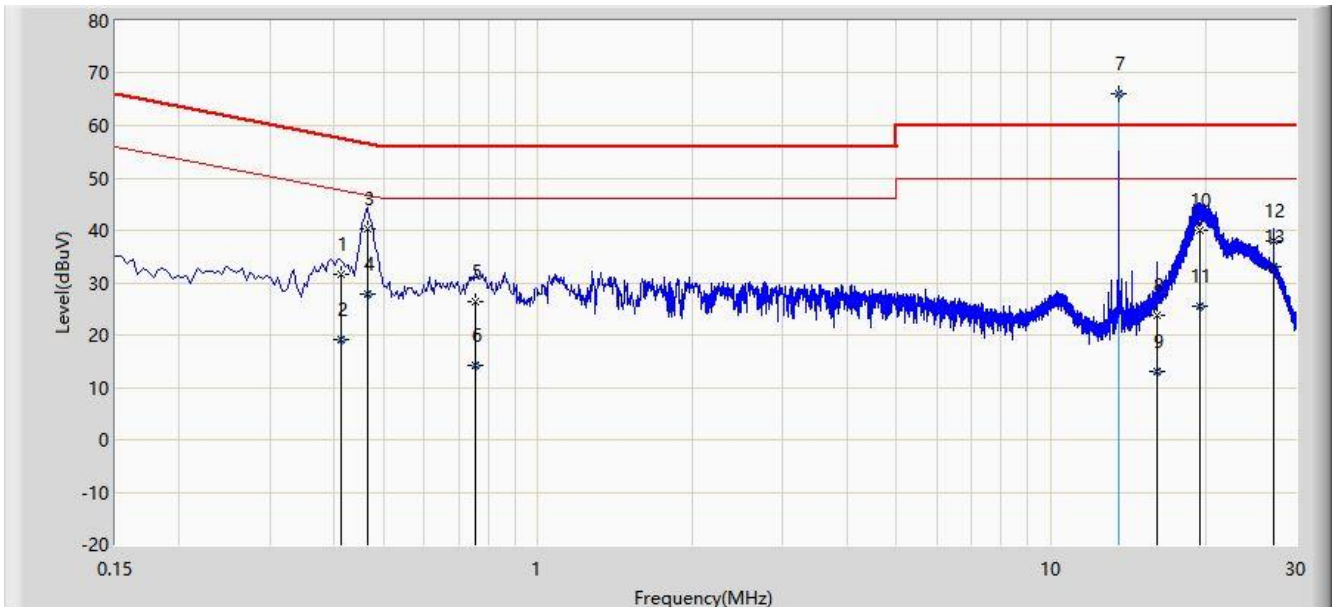

No	Flag	Mark	Frequency (MHz)	Measure Level (dBμV)	Reading Level (dBμV)	Margin (dB)	Limit (dBμV)	Factor (dB)	Type
1			0.414	31.481	21.557	-26.087	57.568	9.924	QP
2			0.414	19.271	9.347	-28.297	47.568	9.924	AV
3		*	0.466	40.358	30.431	-16.227	56.585	9.927	QP
4			0.466	27.884	17.957	-18.701	46.585	9.927	AV
5			0.754	26.239	16.289	-29.761	56.000	9.950	QP
6			0.754	14.244	4.294	-31.756	46.000	9.950	AV
7			13.558	66.167	55.202	N/A	N/A	10.965	PK
8			16.102	23.755	12.590	-36.245	60.000	11.164	QP
9			16.102	12.990	1.826	-37.010	50.000	11.164	AV
10			19.530	39.903	28.259	-20.097	60.000	11.645	QP
11			19.530	25.537	13.892	-24.463	50.000	11.645	AV
12			27.118	38.017	25.981	-21.983	60.000	12.036	QP
13			27.118	33.009	20.973	-16.991	50.000	12.036	AV

Note:

- Point 7 is NFC fundamental frequency.
- Measure Level (dBμV) = Reading Level (dBμV) + Factor (dB)
Factor (dB) = Cable Loss (dB) + LISN Factor (dB).

Appendix B - Test Setup Photograph

Refer to "2111RSU064-UT" file.

Appendix C - EUT Photograph

Refer to "2111RSU064-UE" file.