



RF MEASUREMENT REPORT

FCC ID: HD5-EDA5S1
Applicant: Honeywell International Inc
Honeywell Safety and Productivity Solutions
Product: Mobile Computer
Model No.: EDA5S-1
Brand Name: Honeywell
FCC Classification: Digital Transmission System (DTS)
FCC Rule Part(s): Part 15 Subpart C (Section 15.247)
Test Date: December 15 ~ 29, 2021

Reviewed By:

Jame Yuan

Approved By:

Robin Wu



The test results relate only to the samples tested.

This equipment has been shown to be capable of compliance with the applicable technical standards as indicated in the measurement report and was tested in accordance with the measurement procedures specified in ANSI C63.10-2013. Test results reported herein relate only to the item(s) tested.

The test report shall not be reproduced except in full without the written approval of MRT Technology (Suzhou) Co., Ltd.

Revision History

| Report No. | Version | Description | Issue Date | Note |
|---------------|---------|----------------|------------|-------|
| 2111RSU064-U3 | Rev. 01 | Initial Report | 01-06-2022 | Valid |
| | | | | |

Note: EDA5S-1 is a variation on the existing EDA5S-0 (FCC ID: HD5-EDA5S0), added one LTE chipset, any others are the same. So EDA5S-1 reuse all conducted test data from test report 2111RSU063-U3, and the radiated spurious emission items were fully tested.

CONTENTS

| Description | Page |
|--|-----------|
| 1. General Information | 5 |
| 1.1. Applicant | 5 |
| 1.2. Manufacturer | 5 |
| 1.3. Testing Facility | 5 |
| 1.4. Product Information..... | 6 |
| 1.5. Radio Specification | 6 |
| 1.6. Working Frequencies | 7 |
| 2. Test Configuration | 8 |
| 2.1. Test Mode..... | 8 |
| 2.2. Test System Connection Diagram..... | 8 |
| 2.3. Test Software | 8 |
| 2.4. Applied Standards..... | 9 |
| 2.5. Test Environment Condition | 9 |
| 3. Antenna Requirements | 10 |
| 4. Measuring Instrument | 11 |
| 5. Measurement Uncertainty..... | 12 |
| 6. Test Result..... | 13 |
| 6.1. Summary..... | 13 |
| 6.2. 6dB Bandwidth..... | 14 |
| 6.2.1. Test Limit | 14 |
| 6.2.2. Test Procedure..... | 14 |
| 6.2.3. Test Setting | 14 |
| 6.2.4. Test Setup | 14 |
| 6.2.5. Test Result | 14 |
| 6.3. Output Power | 15 |
| 6.3.1. Test Limit | 15 |
| 6.3.2. Test Procedure..... | 15 |
| 6.3.3. Test Setting | 15 |
| 6.3.4. Test Setup | 15 |
| 6.3.5. Test Result | 15 |
| 6.4. Power Spectral Density..... | 16 |
| 6.4.1. Test Limit | 16 |
| 6.4.2. Test Procedure..... | 16 |
| 6.4.3. Test Setting | 16 |
| 6.4.4. Test Setup | 16 |

| | | |
|---|---|-----------|
| 6.4.5. | Test Result | 17 |
| 6.5. | Conducted Band Edge and Out-of-Band Emissions | 18 |
| 6.5.1. | Test Limit | 18 |
| 6.5.2. | Test Procedure | 18 |
| 6.5.3. | Test Settintg | 18 |
| 6.5.4. | Test Setup | 19 |
| 6.5.5. | Test Result | 19 |
| 6.6. | Radiated Spurious Emission | 20 |
| 6.6.1. | Test Limit | 20 |
| 6.6.2. | Test Procedure | 20 |
| 6.6.3. | Test Setting | 20 |
| 6.6.4. | Test Setup | 22 |
| 6.6.5. | Test Result | 22 |
| 6.7. | Radiated Restricted Band Edge | 23 |
| 6.7.1. | Test Limit | 23 |
| 6.7.2. | Test Procedure | 24 |
| 6.7.3. | Test Setting | 24 |
| 6.7.4. | Test Setup | 25 |
| 6.7.5. | Test Result | 25 |
| 6.8. | AC Conducted Emissions | 26 |
| 6.8.1. | Test Limit | 26 |
| 6.8.2. | Test Setup | 26 |
| 6.8.3. | Test Result | 26 |
| Appendix A – Test Result | | 27 |
| A.1 | Duty Cycle Test Result | 27 |
| A.2 | 6dB Bandwidth Test Result | 28 |
| A.3 | Output Power Test Result | 32 |
| A.4 | Power Spectral Density Test Result | 34 |
| A.5 | Conducted Band Edge and Out-of-Band Emissions Test Result | 38 |
| A.6 | Radiated Spurious Emission Test Result | 42 |
| A.7 | Radiated Restricted Band Edge Test Result | 47 |
| A.8 | AC Conducted Emissions Test Result | 71 |
| Appendix B – Test Setup Photograph | | 73 |
| Appendix C – EUT Photograph | | 74 |

1.4. Product Information

| | |
|---|---|
| Product Name | Mobile Computer |
| Model No. | EDA5S-1 |
| Serial No. | Conducted Sample: 21294B506A Radiated Sample: 21294B3F94 |
| Wi-Fi Specification | 802.11a/b/g/n/ac |
| Bluetooth Specification | v5.0 dual mode |
| NFC Specification | Active, 13.56MHz |
| GNSS Specification | GPS/Galileo/BDS/GLONASS |
| 3GPP Specification | GSM 850/1900 WCDMA Band 2/4/5 LTE Band 2/4/5/7/12/13/17/25/26/30/38/40/41/66 |
| Working Voltage | 3.85Vdc |
| Accessories | |
| Adapter | Model No.: ADS-12B-06 05010E Input Power: 100 - 240V ~ 50/60Hz, Max. 0.3A Output Power: 5VDC 2.0A |
| Rechargeable Li-ion Battery | Model No.: BAT-EDA5S Capacitance: 3060mAh 11.78Wh Rated Voltage: 3.85V |
| Remark: The information of EUT was provided by the manufacturer, and the accuracy of the information shall be the responsibility of the manufacturer. | |

1.5. Radio Specification

| | |
|--------------------|---|
| Frequency Range | 802.11b/g/n-HT20: 2412 ~ 2462MHz |
| Channel Number | 802.11b/g/n-HT20: 11 |
| Type of Modulation | 802.11b: DSSS 802.11g/n: OFDM |
| Data Rate | 802.11b: 1/2/5.5/11Mbps 802.11g: 6/9/12/18/24/36/48/54Mbps 802.11n: up to 150Mbps |
| Antenna Type | FPC Antenna |
| Antenna Gain | 1.78dBi |

Note: For other features of this EUT, test report will be issued separately.

1.6. Working Frequencies

802.11b/g/n-HT20

| Channel | Frequency | Channel | Frequency | Channel | Frequency |
|---------|-----------|---------|-----------|---------|-----------|
| 01 | 2412 MHz | 02 | 2417 MHz | 03 | 2422 MHz |
| 04 | 2427 MHz | 05 | 2432 MHz | 06 | 2437 MHz |
| 07 | 2442 MHz | 08 | 2447 MHz | 09 | 2452 MHz |
| 10 | 2457 MHz | 11 | 2462 MHz | -- | -- |

2. Test Configuration

2.1. Test Mode

| |
|---|
| Mode 1: Transmit by 802.11b (1Mbps) |
| Mode 2: Transmit by 802.11g (24Mbps) |
| Mode 3: Transmit by 802.11n-HT20 (MCS7) |

2.2. Test System Connection Diagram

The device was tested per the guidance ANSI C63.10: 2013 was used to reference the appropriate EUT setup for radiated emissions testing and AC line conducted testing.

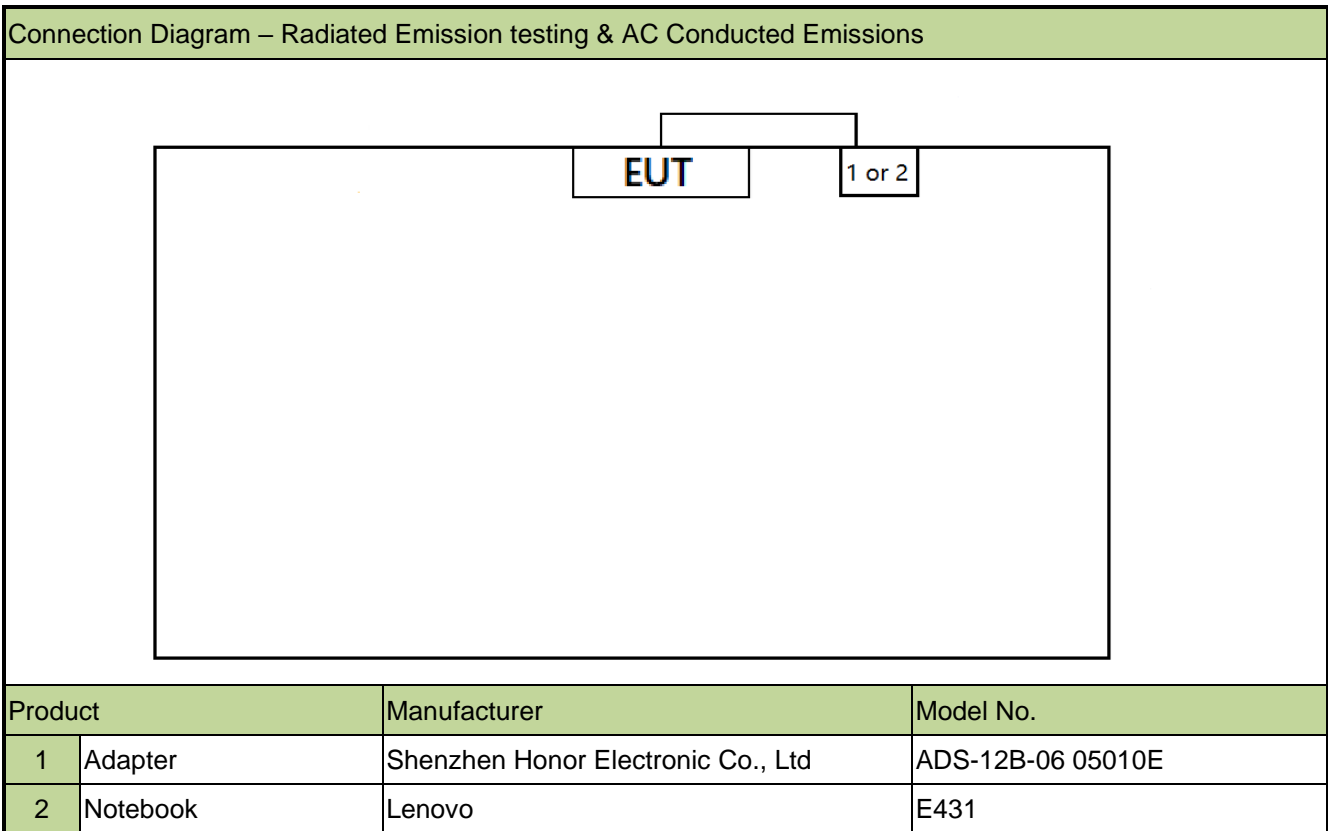

2.3. Test Software

The test utility software used during testing was “QRCT”, and the version was 3.0.268.0..

2.4. Applied Standards

According to the specifications of the manufacturer, the EUT must comply with the requirements of the following standards:

- FCC Part 15.247
- KDB 558074 D01v05r02
- ANSI C63.10-2013

2.5. Test Environment Condition

| | |
|---------------------|------------|
| Ambient Temperature | 15 ~ 35°C |
| Relative Humidity | 20 ~ 75%RH |

3. Antenna Requirements

Excerpt from §15.203 of the FCC Rules/Regulations:

“An intentional radiator antenna shall be designed to ensure that no antenna other than that furnished by the responsible party can be used with the device. The use of a permanently attached antenna or of an antenna that uses a unique coupling to the intentional radiator shall be considered sufficient to comply with the provisions of this section.”

- The antenna of the device is **permanently attached**.
- There are no provisions for connection to an external antenna.

Conclusion:

The unit complies with the requirement of §15.203.

4. Measuring Instrument

| Instrument | Manufacturer | Model No. | Asset No. | Cali. Interval | Cali. Due Date | Test Site |
|---------------------|--------------|-------------|-------------|----------------|----------------|---------------|
| Horn Antenna | Schwarzbeck | BBHA 9170 | MRTSUE06292 | 1 year | 2022/10/20 | NS-AC1 |
| Anechoic Chamber | BOOMWAVE | NS-AC1 | MRTSUE06496 | 1 year | 2022/7/24 | NS-AC1 |
| Horn Antenna | Schwarzbeck | BBHA 9120D | MRTSUE06572 | 1 year | 2022/3/14 | NS-AC1 |
| TRILOG Antenna | Schwarzbeck | VULB 9162 | MRTSUE06573 | 1 year | 2022/6/29 | NS-AC1 |
| Loop Antenna | Schwarzbeck | FMZB 1519 B | MRTSUE06937 | 1 year | 2022/3/9 | SIP-AC1 |
| Preamplifier | Schwarzbeck | BBV 9718 | MRTSUE06574 | 1 year | 2022/7/12 | NS-AC1 |
| EMI Test Receiver | R&S | ESR3 | MRTSUE06575 | 1 year | 2022/6/27 | NS-AC1 |
| Thermohygrometer | DELI | NO.8813 | MRTSUE06588 | 1 year | 2022/6/30 | NS-AC1 |
| Preamplifier | EMCI | EMC184045SE | MRTSUE06641 | 1 year | 2022/1/14 | NS-AC1 |
| Signal Analyzer | Agilent | N9010A | MRTSUE06195 | 1 year | 2022/3/17 | NS-AC1/NS-TR2 |
| Signal Analyzer | Keysight | N9020A | MRTSUE10065 | 1 year | 2022/6/17 | NS-AC1/NS-TR2 |
| Shielding Room | BOOMWAVE | NS-SR2 | MRTSUE06551 | / | / | NS-SR2 |
| EMI Test Receiver | R&S | ESL3 | MRTSUE06576 | 1 year | 2022/6/27 | NS-SR2 |
| Two-Line V-Network | R&S | ENV216 | MRTSUE06577 | 1 year | 2022/7/4 | NS-SR2 |
| Two-Line V-Network | R&S | ENV216 | MRTSUE06578 | 1 year | 2022/7/4 | NS-SR2 |
| ISN | R&S | ENY81 | MRTSUE06579 | 1 year | 2022/7/4 | NS-SR2 |
| ISN | R&S | ENY81-CA6 | MRTSUE06580 | 1 year | 2022/6/15 | NS-SR2 |
| Thermohygrometer | DELI | NO.8813 | MRTSUE06587 | 1 year | 2022/6/30 | NS-SR2 |
| USB Power Sensor | Keysight | U2021XA | MRTSUE06581 | 1 year | 2022/8/15 | NS-TR2 |
| Thermohygrometer | DELI | NO.8813 | MRTSUE06783 | 1 year | 2022/5/9 | NS-TR2 |
| Temperature Chamber | OUKE | OK-TH-100C | MRTSUE06899 | 1 year | 2022/11/1 | NS-TR2 |

| Software | Version | Function |
|--------------|---------|-------------------|
| EMI Software | V3 | EMI Test Software |

Note: Test site (NS-AC1 & NS-SR2 & NS-TR2) belong to MRT Shenzhen Laboratory, Test site (SIP-AC1) belong to MRT Suzhou Laboratory.

5. Measurement Uncertainty

Where relevant, the following test uncertainty levels have been estimated for tests performed on the EUT as specified in CISPR 16-4-2. This uncertainty represents an expanded uncertainty expressed at approximately the 95% confidence level using a coverage factor of $k = 2$.

| |
|--|
| AC Conducted Emission Measurement |
| Measurement Uncertainty for a Level of Confidence of 95% ($U=2Uc(y)$): 9kHz~150kHz: 3.74dB 150kHz~30MHz: 3.44dB |
| Radiated Disturbance |
| Measurement Uncertainty for a Level of Confidence of 95% ($U=2Uc(y)$): Horizontal: 30MHz~300MHz: 5.04dB 300MHz~1GHz: 4.95dB 1GHz~40GHz: 6.40dB Vertical: 30MHz~300MHz: 5.24dB 300MHz~1GHz: 6.03dB 1GHz~40GHz: 6.40dB |
| Spurious Emissions, Conducted |
| Measuring Uncertainty for a Level of Confidence of 95% ($U=2Uc(y)$): 0.78dB |
| Output Power |
| Measuring Uncertainty for a Level of Confidence of 95% ($U=2Uc(y)$): 1.13dB |
| Power Spectrum Density |
| Measuring Uncertainty for a Level of Confidence of 95% ($U=2Uc(y)$): 1.15dB |
| Occupied Bandwidth |
| Measuring Uncertainty for a Level of Confidence of 95% ($U=2Uc(y)$): 0.28% |

6. Test Result

6.1. Summary

| FCC Section(s) | Test Description | Test Condition | Verdict |
|------------------|---|----------------|---------|
| 15.247(a)(2) | 6dB Bandwidth | Conducted | Pass |
| 15.247(b)(3) | Output Power | | Pass |
| 15.247(e) | Power Spectral Density | | Pass |
| 15.247(d) | Band Edge / Out-of-Band Emissions | | Pass |
| 15.205 15.209 | General Field Strength (Restricted Bands and Radiated Emission) | Radiated | Pass |
| 15.207 | AC Conducted Emissions 150kHz - 30MHz | Line Conducted | Pass |

Remark:

1. The analyzer plots shown in this section were all taken with a correction table loaded into the analyzer. The correction table was used to account for the losses of the cables and attenuators used as part of the system to connect the EUT to the analyzer at all frequencies of interest.
2. For radiated emission tests, every axis (X, Y, Z) was also verified. The test results shown in the following sections represent the worst-case emissions.

6.2. 6dB Bandwidth

6.2.1. Test Limit

The minimum 6dB bandwidth shall be at least 500 kHz.

6.2.2. Test Procedure

ANSI C63.10 - 2013 - Section 11.8

6.2.3. Test Setting

1. The Spectrum's automatic bandwidth measurement capability was used to perform the 6dB bandwidth measurement. The "X" dB bandwidth parameter was set to $X = 6$. The bandwidth measurement was not influenced by any intermediate power nulls in the fundamental emission.
2. Set RBW = 100 kHz
3. VBW $\geq 3 \times$ RBW
4. Detector = Peak
5. Trace mode = Max hold
6. Sweep = Auto couple
7. Allow the trace to stabilize

6.2.4. Test Setup

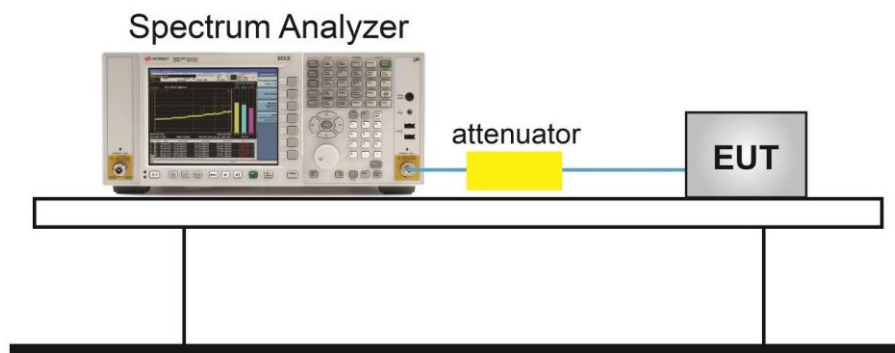

6.2.5. Test Result

Refer to Appendix A.2.

6.3. Output Power

6.3.1. Test Limit

The maximum output power shall be less 1 Watt (30dBm).

The conducted output power limit specified in paragraph FCC Part 15.247(b) of this section is based on the use of antennas with directional gains that do not exceed 6 dBi. If transmitting antennas of directional gain greater than 6 dBi are used, the conducted output power from the intentional radiator shall be reduced below the stated values in paragraphs FCC Part 15.247(b)(3) of this section, as appropriate, by the amount in dB that the directional gain of the antenna exceeds 6 dBi.

6.3.2. Test Procedure

ANSI C63.10 - 2013 - Section 11.9.2.3.2

6.3.3. Test Setting

Average Power Measurement

Average power measurements were performed only when the EUT was transmitting at its maximum power control level using a broadband power meter with a pulse sensor. The power meter implemented triggering and gating capabilities which were set up such that power measurements were recorded only during the ON time of the transmitter.

6.3.4. Test Setup

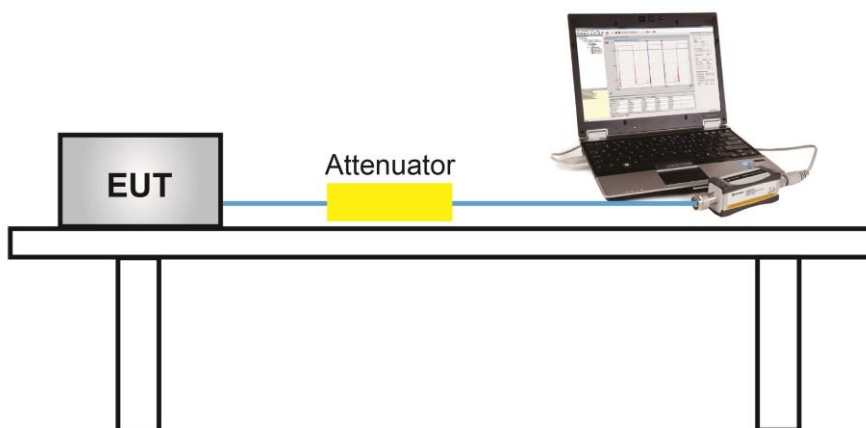

6.3.5. Test Result

Refer to Appendix A.3.

6.4. Power Spectral Density

6.4.1. Test Limit

The maximum permissible power spectral density is 8dBm in any 3 kHz band.

The same method of determining the conducted output power shall be used to determine the power spectral density.

6.4.2. Test Procedure

ANSI C63.10 - 2013 - Section 11.10.2

6.4.3. Test Setting

1. Analyzer was set to the center frequency of the DTS channel under investigation
2. Span = 1.5 times the OBW
3. RBW = 3kHz
4. VBW = 10kHz
5. Detector = Peak
6. Sweep time = Auto couple
7. Trace mode = Max hold
8. Trace was allowed to stabilize

6.4.4. Test Setup

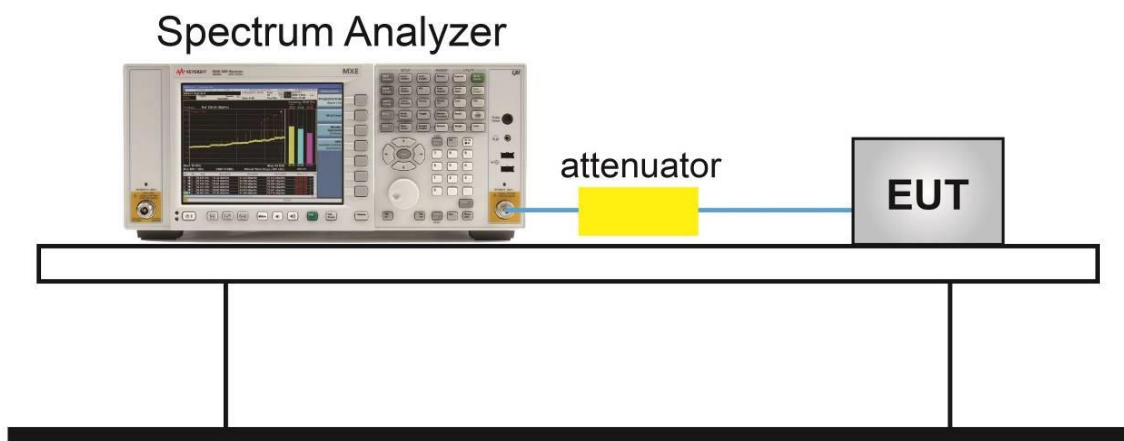

6.4.5. Test Result

Refer to Appendix A.4.

6.5. Conducted Band Edge and Out-of-Band Emissions

6.5.1. Test Limit

The limit for out-of-band spurious emissions at the band edge is 20dB below the fundamental emission level, as determined from the in-band power measurement of the DTS channel performed in a 100 kHz bandwidth per the PSD procedure.

6.5.2. Test Procedure

ANSI C63.10-2013 - Section 11.11

6.5.3. Test Setting

Reference level measurement

1. Set instrument center frequency to DTS channel center frequency
2. Set the span to ≥ 1.5 times the DTS bandwidth
3. Set the RBW = 100 kHz
4. Set the VBW $\geq 3 \times$ RBW
5. Detector = peak
6. Sweep time = auto couple
7. Trace mode = max hold
8. Allow trace to fully stabilize

Emission level measurement

1. Set the center frequency and span to encompass frequency range to be measured
2. RBW = 100kHz
3. VBW = 300kHz
4. Detector = Peak
5. Trace mode = max hold
6. Sweep time = auto couple
7. The trace was allowed to stabilize

6.5.4. Test Setup

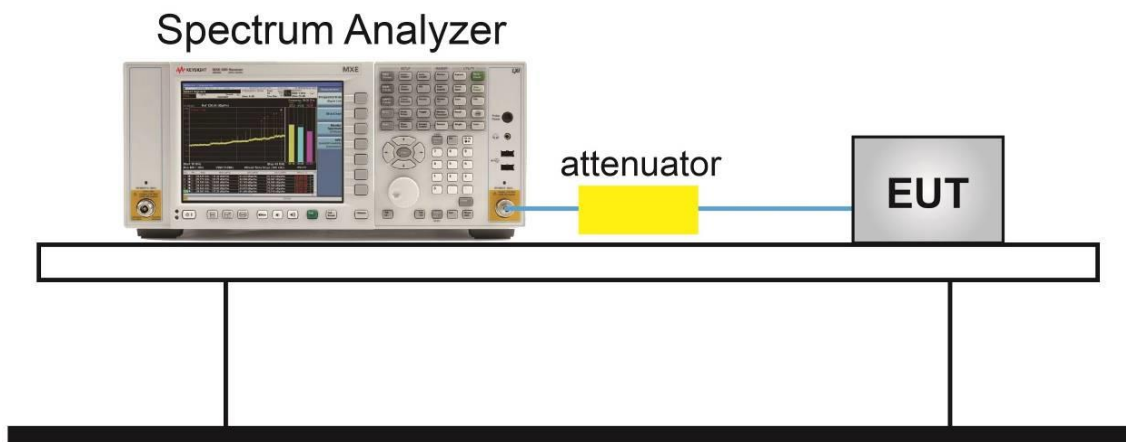

6.5.5. Test Result

Refer to Appendix A.5.

6.6. Radiated Spurious Emission

6.6.1. Test Limit

All out of band emissions appearing in a restricted band as specified in Section 15.205 of the Title 47 CFR must not exceed the limits shown in Table per Section 15.209.

| FCC Part 15 Subpart C Paragraph 15.209 | | |
|--|--------------------------|-------------------------------|
| Frequency [MHz] | Field Strength [uV/m] | Measured Distance [Meters] |
| 0.009 - 0.490 | 2400/F (kHz) | 300 |
| 0.490 - 1.705 | 24000/F (kHz) | 30 |
| 1.705 - 30 | 30 | 30 |
| 30 - 88 | 100 | 3 |
| 88 - 216 | 150 | 3 |
| 216 - 960 | 200 | 3 |
| Above 960 | 500 | 3 |

6.6.2. Test Procedure

ANSI C63.10 - 2013 - Section 11.11 & 11.12

ANSI C63.10 - 2013 - Section 6.3 (General Requirements)

ANSI C63.10 - 2013 - Section 6.4 (Standard test method below 30MHz)

ANSI C63.10 - 2013 - Section 6.5 (Standard test method above 30MHz to 1GHz)

ANSI C63.10 - 2013 - Section 6.6 (Standard test method above 1GHz)

6.6.3. Test Setting

Table 1 - RBW as a function of frequency

| Frequency | RBW |
|---------------|---------------|
| 9 ~ 150 kHz | 200 ~ 300 Hz |
| 0.15 ~ 30 MHz | 9 ~ 10 kHz |
| 30 ~ 1000 MHz | 100 ~ 120 kHz |
| > 1000MHz | 1MHz |

Quasi-Peak Measurements below 1GHz

1. Analyzer center frequency was set to the frequency of the radiated spurious emission of interest
2. Span was set greater than 1MHz
3. RBW = as specified in Table 1
4. Detector = CISPR quasi-peak
5. Sweep time = auto couple
6. Trace was allowed to stabilize

Peak Measurements above 1GHz

1. Analyzer center frequency was set to the frequency of the radiated spurious emission of interest
2. RBW = 1MHz
3. VBW = 3MHz
4. Detector = peak
5. Sweep time = auto couple
6. Trace mode = max hold
7. Trace was allowed to stabilize

Average Measurements above 1GHz (Method VB)

1. Analyzer center frequency was set to the frequency of the radiated spurious emission of interest
2. RBW = 1MHz
3. VBW; If the EUT is configured to transmit with duty cycle $\geq 98\%$, set VBW = 10 Hz.
If the EUT duty cycle is $< 98\%$, set VBW $\geq 1/T$. T is the minimum transmission duration.
4. Detector = Peak
5. Sweep time = auto
6. Trace mode = max hold
7. Trace was allowed to stabilize

6.6.4. Test Setup

Below 1GHz Test Setup:

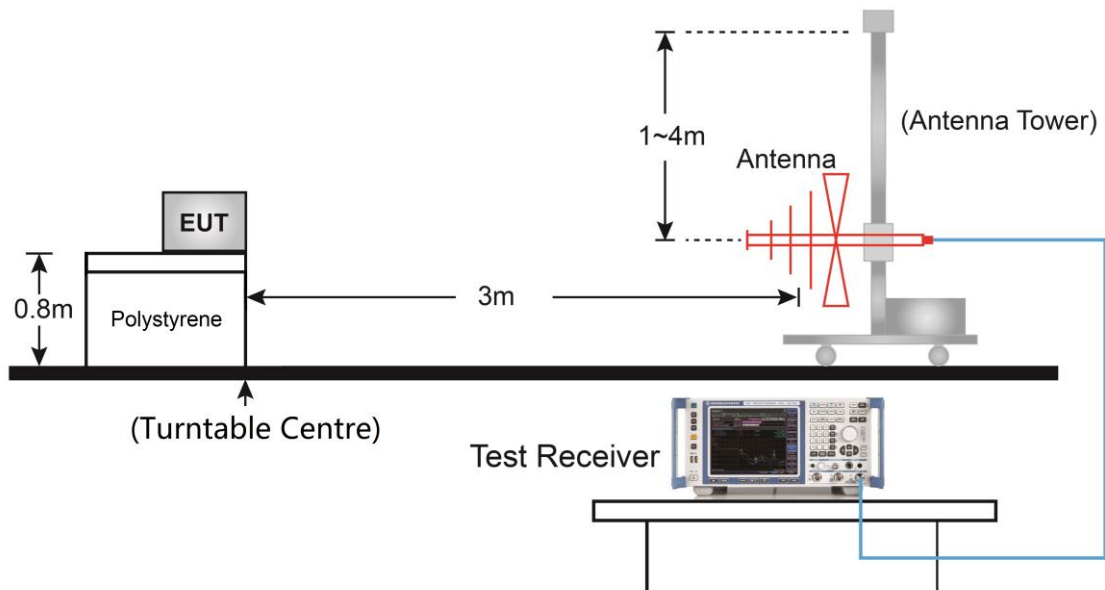

Above 1GHz Test Setup:

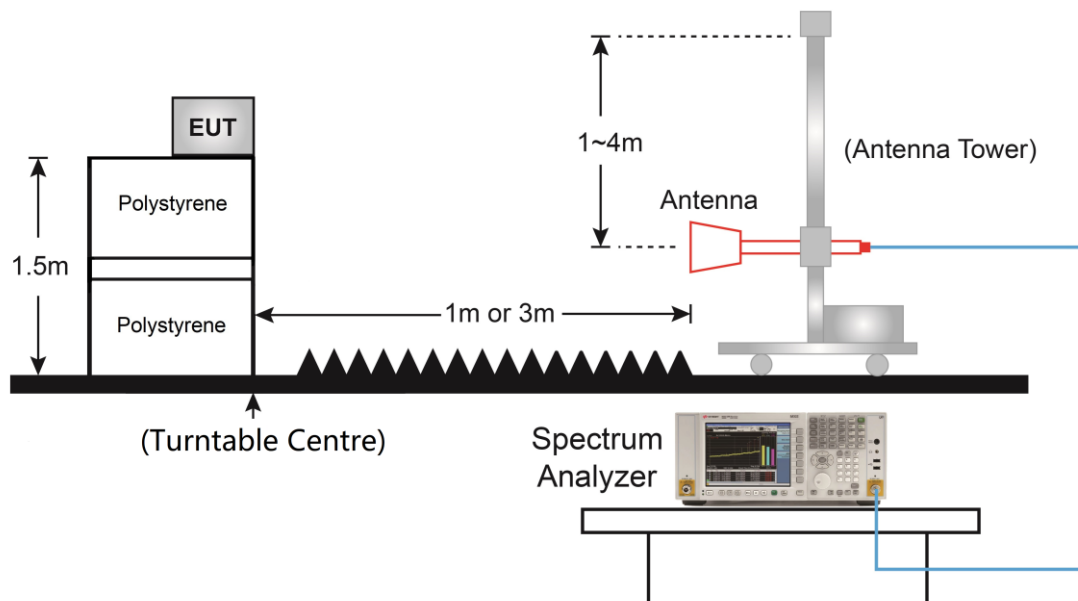

6.6.5. Test Result

Refer to Appendix A.6.

6.7. Radiated Restricted Band Edge

6.7.1. Test Limit

For 15.205 requirement:

Radiated emissions which fall in the restricted bands, as defined in Section 15.205(a) of FCC part 15, must also comply with the radiated emission limits specified in Section 15.209(a).

| Frequency (MHz) | Frequency (MHz) | Frequency (MHz) | Frequency (GHz) |
|----------------------------|-----------------------|--------------------|--------------------|
| 0.090 - 0.110 | 16.42 - 16.423 | 399.9 - 410 | 4.5 - 5.15 |
| ¹ 0.495 - 0.505 | 16.69475 - 16.69525 | 608 - 614 | 5.35 - 5.46 |
| 2.1735 - 2.1905 | 16.80425 - 16.80475 | 960 - 1240 | 7.25 - 7.75 |
| 4.125 - 4.128 | 25.5 - 25.67 | 1300 - 1427 | 8.025 - 8.5 |
| 4.17725 - 4.17775 | 37.5 - 38.25 | 1435 - 1626.5 | 9.0 - 9.2 |
| 4.20725 - 4.20775 | 73 - 74.6 | 1645.5 - 1646.5 | 9.3 - 9.5 |
| 6.215 - 6.218 | 74.8 - 75.2 | 1660 - 1710 | 10.6 - 12.7 |
| 6.26775 - 6.26825 | 108 - 121.94 | 1718.8 - 1722.2 | 13.25 - 13.4 |
| 6.31175 - 6.31225 | 123 - 138 | 2200 - 2300 | 14.47 - 14.5 |
| 8.291 - 8.294 | 149.9 - 150.05 | 2310 - 2390 | 15.35 - 16.2 |
| 8.362 - 8.366 | 156.52475 - 156.52525 | 2483.5 - 2500 | 17.7 - 21.4 |
| 8.37625 - 8.38675 | 156.7 - 156.9 | 2690 - 2900 | 22.01 - 23.12 |
| 8.41425 - 8.41475 | 162.0125 - 167.17 | 3260 - 3267 | 23.6 - 24.0 |
| 12.29 - 12.293 | 167.72 - 173.2 | 3332 - 3339 | 31.2 - 31.8 |
| 12.51975 - 12.52025 | 240 - 285 | 3345.8 - 3358 | 36.43 - 36.5 |
| 12.57675 - 12.57725 | 322 - 335.4 | 3600 - 4400 | (²) |
| 13.36 - 13.41 | -- | -- | -- |

All out of band emissions appearing in a restricted band as specified in Section 15.205 of the Title 47CFR must not exceed the limits shown in Table per Section 15.209.

| FCC Part 15 Subpart C Paragraph 15.209 | | |
|--|--------------------------|-------------------------------|
| Frequency [MHz] | Field Strength [uV/m] | Measured Distance [Meters] |
| 0.009 - 0.490 | 2400/F (kHz) | 300 |
| 0.490 - 1.705 | 24000/F (kHz) | 30 |
| 1.705 - 30 | 30 | 30 |
| 30 - 88 | 100 | 3 |
| 88 - 216 | 150 | 3 |
| 216 - 960 | 200 | 3 |
| Above 960 | 500 | 3 |

6.7.2. Test Procedure

ANSI C63.10-2013 Section 6.3

ANSI C63.10-2013 Section 6.6

ANSI C63.10-2013 Section 11.13

6.7.3. Test Setting

Peak Field Strength Measurements

1. Analyzer center frequency was set to the frequency of the radiated spurious emission of interest
2. RBW = 1MHz
3. VBW = 3MHz
4. Detector = peak
5. Sweep time = auto couple
6. Trace mode = max hold
7. Trace was allowed to stabilize

Average Field Strength Measurements

1. Analyzer center frequency was set to the frequency of the radiated spurious emission of interest
2. RBW = 1MHz
3. VBW $\geq 1/T$
4. As an alternative, the instrument may be set to linear detector mode. Ensure that video filtering is applied in linear voltage domain (rather than in a log or dB domain). Some instruments require linear display mode in order to accomplish this. Others have a setting for Average-VBW Type, which can be set to "Voltage" regardless of the display mode
5. Detector = Peak
6. Sweep time = auto
7. Trace mode = max hold
8. Allow max hold to run for at least 50 times (1/duty cycle) traces

6.7.4. Test Setup

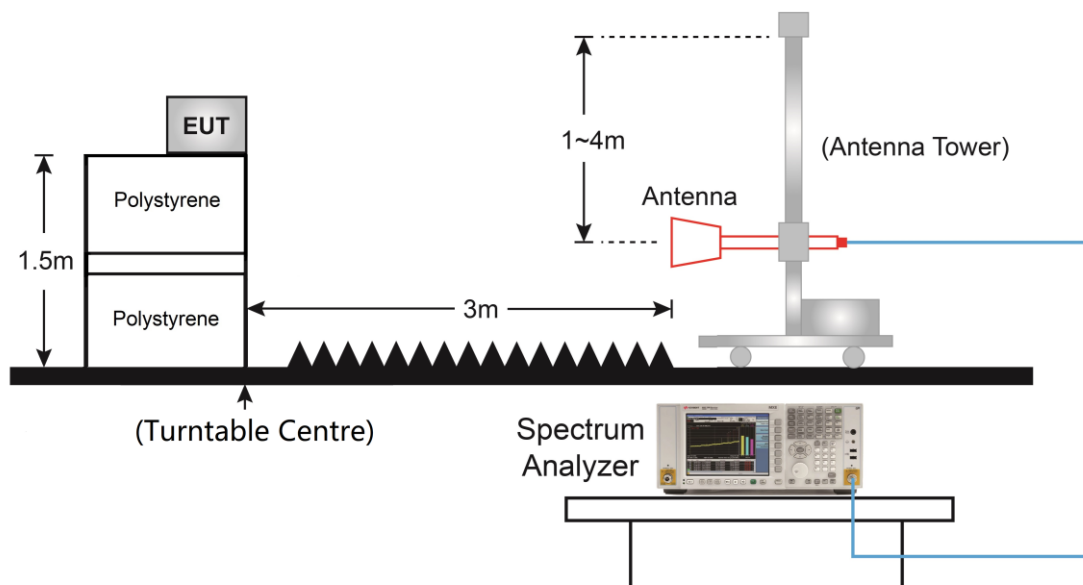

6.7.5. Test Result

Refer to Appendix A.7.

6.8. AC Conducted Emissions

6.8.1. Test Limit

| FCC Part 15 Subpart C Paragraph 15.207 Limits | | |
|---|-----------|-----------|
| Frequency (MHz) | QP (dBuV) | AV (dBuV) |
| 0.15 - 0.50 | 66 - 56 | 56 - 46 |
| 0.50 - 5.0 | 56 | 46 |
| 5.0 - 30 | 60 | 50 |

Note 1: The lower limit shall apply at the transition frequencies.

Note 2: The limit decreases linearly with the logarithm of the frequency in the range 0.15MHz to 0.5MHz.

6.8.2. Test Setup

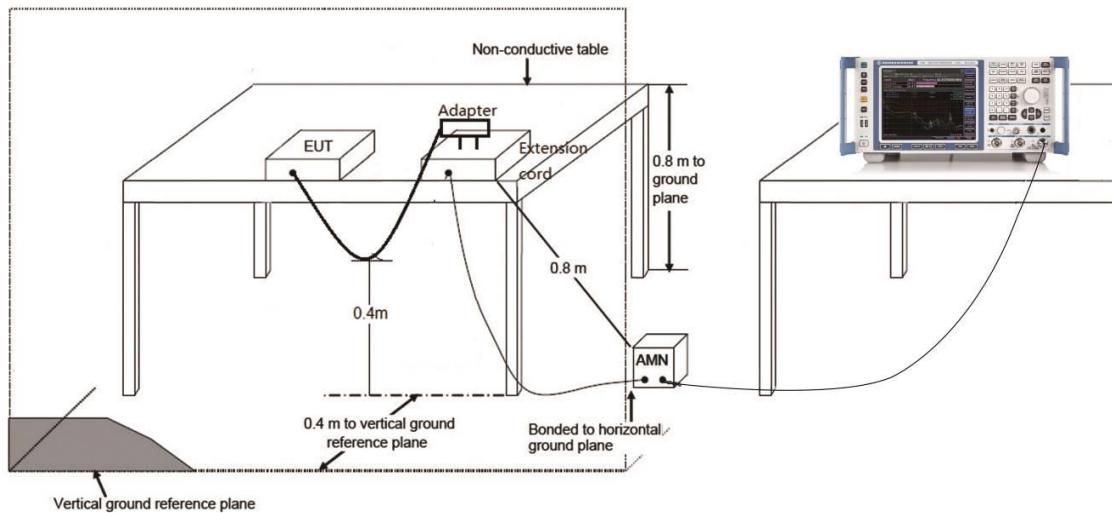

6.8.3. Test Result

Refer to Appendix A.8.

Appendix A – Test Result

A.1 Duty Cycle Test Result

| | | | |
|-----------|------------|---------------|-------------|
| Test Site | NS-TR2 | Test Engineer | Summer Tang |
| Test Date | 2021/12/15 | | |

| Test Mode | Duty Cycle |
|--------------|------------|
| 802.11b | 97.79% |
| 802.11g | 92.98% |
| 802.11n-HT20 | 86.17% |

Duty Cycle (T = Transmission Duration)

802.11b (T = 12.40ms)

802.11g (T = 527.5us)

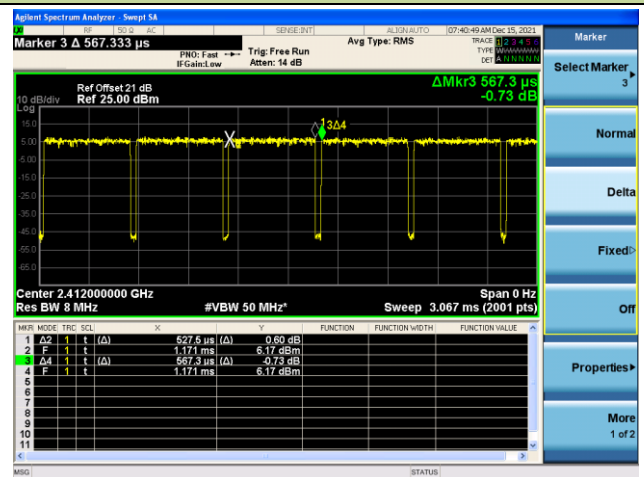
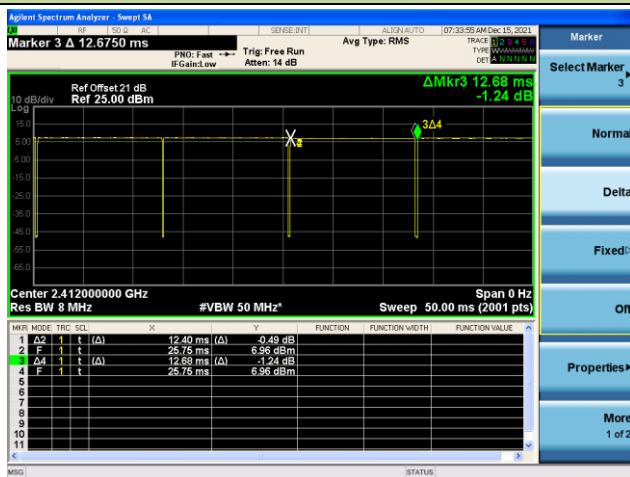

802.11n-HT20 (T = 227.5us)

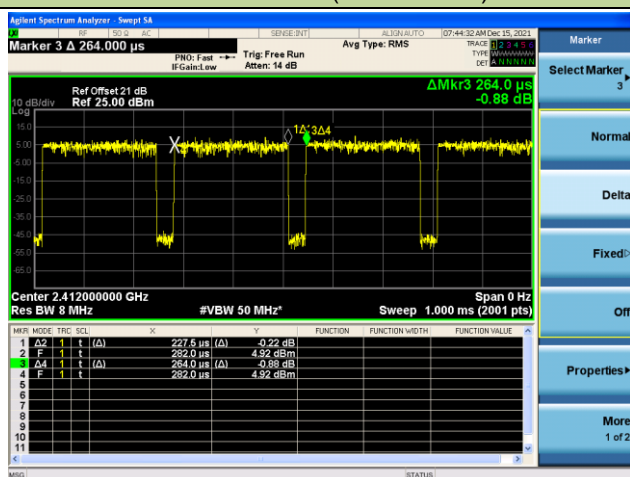

A.2 6dB Bandwidth Test Result

| | | | |
|-----------|------------|---------------|-------------|
| Test Site | NS-TR2 | Test Engineer | Summer Tang |
| Test Date | 2021/12/21 | | |

| Test Mode | Data Rate / MCS | Channel No. | Frequency (MHz) | 6dB Bandwidth (MHz) | Limit (MHz) |
|-----------|-----------------|-------------|-----------------|---------------------|-------------|
| 11b | 1Mbps | 01 | 2412 | 8.125 | ≥ 0.5 |
| 11b | 1Mbps | 06 | 2437 | 8.126 | ≥ 0.5 |
| 11b | 1Mbps | 11 | 2462 | 8.115 | ≥ 0.5 |
| 11g | 6Mbps | 01 | 2412 | 16.37 | ≥ 0.5 |
| 11g | 6Mbps | 06 | 2437 | 16.39 | ≥ 0.5 |
| 11g | 6Mbps | 11 | 2462 | 16.11 | ≥ 0.5 |
| 11n-HT20 | MCS0 | 01 | 2412 | 17.75 | ≥ 0.5 |
| 11n-HT20 | MCS0 | 06 | 2437 | 17.74 | ≥ 0.5 |
| 11n-HT20 | MCS0 | 11 | 2462 | 17.70 | ≥ 0.5 |

802.11b 6dB Bandwidth

Channel 01 (2412MHz)

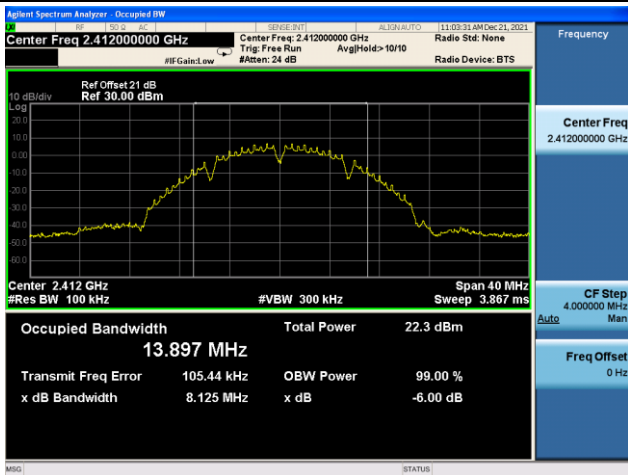

Channel 06 (2437MHz)

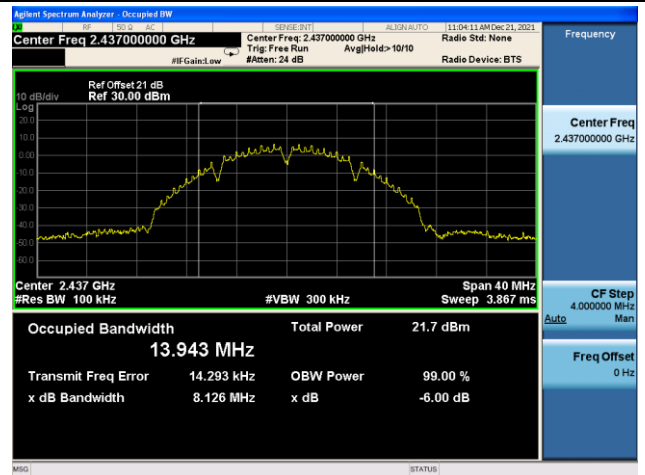

Channel 11 (2462MHz)

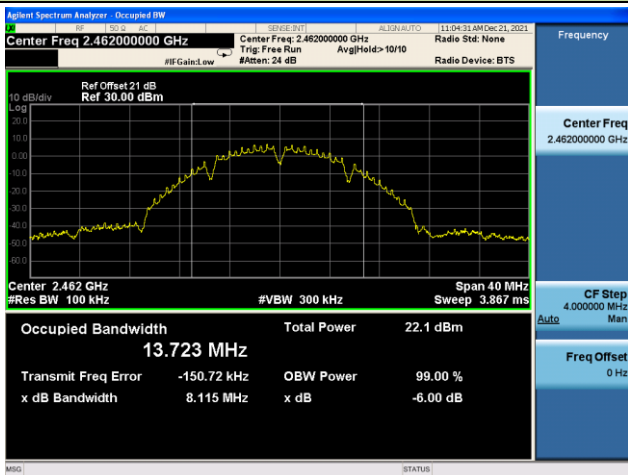

802.11g 6dB Bandwidth

Channel 01 (2412MHz)

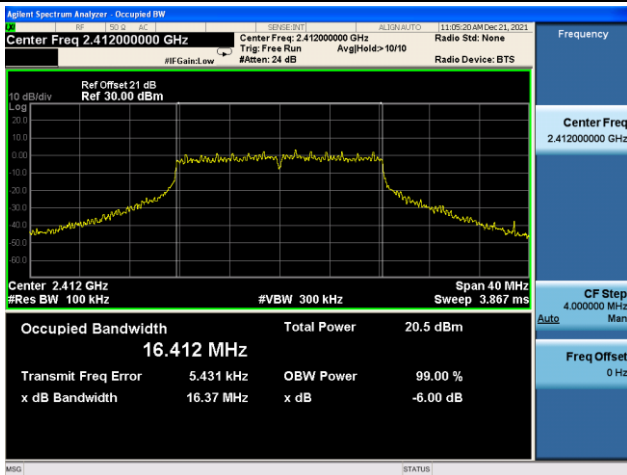

Channel 06 (2437MHz)

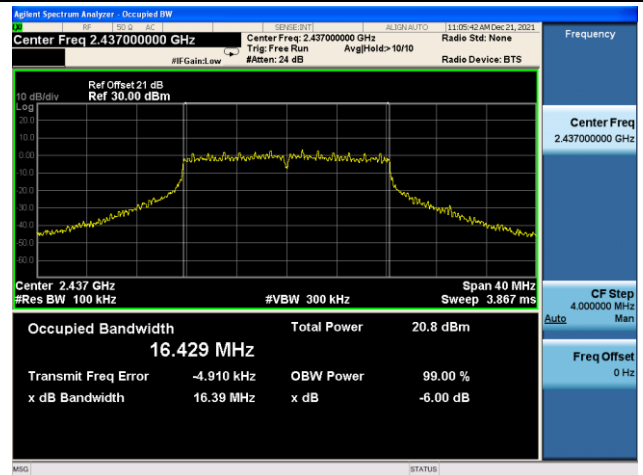

Channel 11 (2462MHz)

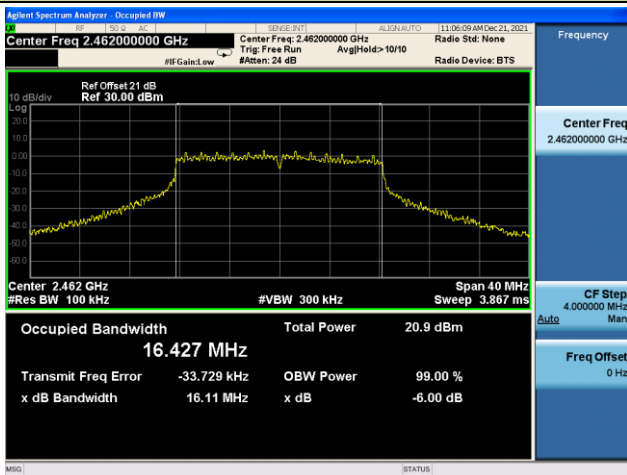

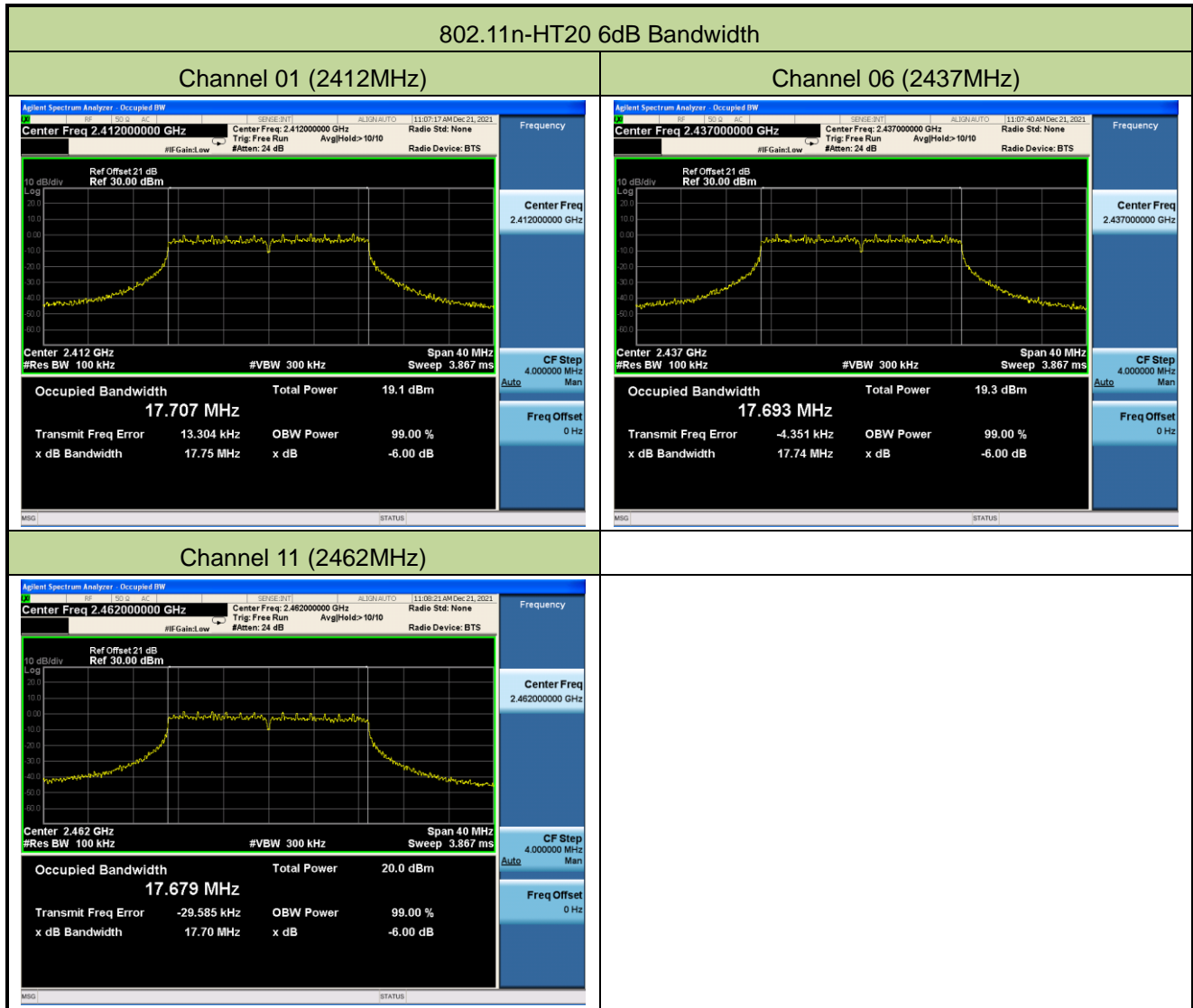

A.3 Output Power Test Result

Power output test was verified over all data rates of each mode shown as below, and then choose the maximum power output (gray marker) for final test of each channel.

| Test Mode | Bandwidth (MHz) | Channel No. | Frequency (MHz) | Data Rate / MCS | Average Power (dBm) |
|-----------|-----------------|-------------|-----------------|-----------------|---------------------|
| 802.11b | 20 | 1 | 2412 | 1Mbps | 9.68 |
| | | | | 5.5Mbps | 9.65 |
| | | | | 11Mbps | 9.63 |
| 802.11g | 20 | 1 | 2412 | 6Mbps | 9.03 |
| | | | | 24Mbps | 9.56 |
| | | | | 54Mbps | 9.23 |
| 802.11n | 20 | 1 | 2412 | MCS0 | 8.93 |
| | | | | MCS3 | 8.86 |
| | | | | MCS7 | 9.33 |

| | | | |
|-----------|------------|---------------|-------------|
| Test Site | NS-TR2 | Test Engineer | Summer Tang |
| Test Date | 2021/12/16 | | |

Test Result of Peak Output Power

| Test Mode | Data Rate/ MCS | Channel No. | Freq. (MHz) | Peak Power (dBm) | Limit (dBm) |
|-----------|-------------------|-------------|----------------|---------------------|----------------|
| 11b | 1Mbps | 01 | 2412 | 17.08 | ≤ 30.00 |
| 11b | 1Mbps | 06 | 2437 | 17.11 | ≤ 30.00 |
| 11b | 1Mbps | 11 | 2462 | 17.26 | ≤ 30.00 |
| 11g | 24Mbps | 01 | 2412 | 18.71 | ≤ 30.00 |
| 11g | 24Mbps | 06 | 2437 | 19.20 | ≤ 30.00 |
| 11g | 24Mbps | 11 | 2462 | 19.51 | ≤ 30.00 |
| 11n-HT20 | MCS7 | 01 | 2412 | 21.10 | ≤ 30.00 |
| 11n-HT20 | MCS7 | 06 | 2437 | 21.62 | ≤ 30.00 |
| 11n-HT20 | MCS7 | 11 | 2462 | 21.43 | ≤ 30.00 |

Test Result of Average Output Power (Reporting Only)

| Test Mode | Data Rate/ MCS | Channel No. | Freq. (MHz) | Average Power (dBm) | Limit (dBm) |
|-----------|-------------------|-------------|----------------|------------------------|----------------|
| 11b | 1Mbps | 01 | 2412 | 14.98 | ≤ 30.00 |
| 11b | 1Mbps | 06 | 2437 | 14.78 | ≤ 30.00 |
| 11b | 1Mbps | 11 | 2462 | 15.15 | ≤ 30.00 |
| 11g | 24Mbps | 01 | 2412 | 12.86 | ≤ 30.00 |
| 11g | 24Mbps | 06 | 2437 | 12.88 | ≤ 30.00 |
| 11g | 24Mbps | 11 | 2462 | 13.14 | ≤ 30.00 |
| 11n-HT20 | MCS7 | 01 | 2412 | 11.76 | ≤ 30.00 |
| 11n-HT20 | MCS7 | 06 | 2437 | 11.98 | ≤ 30.00 |
| 11n-HT20 | MCS7 | 11 | 2462 | 12.19 | ≤ 30.00 |

A.4 Power Spectral Density Test Result

| | | | |
|-----------|------------|---------------|-------------|
| Test Site | NS-TR2 | Test Engineer | Summer Tang |
| Test Date | 2021/12/29 | | |

| Test Mode | Data Rate/ MCS | Channel No. | Freq. (MHz) | PKPSD (dBm / 3kHz) | Limit (dBm / 3kHz) | Result |
|-----------|-------------------|----------------|----------------|-----------------------|-----------------------|--------|
| 11b | 1Mbps | 01 | 2412 | 5.11 | ≤ 8.00 | Pass |
| 11b | 1Mbps | 06 | 2437 | 5.33 | ≤ 8.00 | Pass |
| 11b | 1Mbps | 11 | 2462 | 5.80 | ≤ 8.00 | Pass |
| 11g | 24Mbps | 01 | 2412 | -12.75 | ≤ 8.00 | Pass |
| 11g | 24Mbps | 06 | 2437 | -12.04 | ≤ 8.00 | Pass |
| 11g | 24Mbps | 11 | 2462 | -12.18 | ≤ 8.00 | Pass |
| 11n-HT20 | MCS7 | 01 | 2412 | -14.97 | ≤ 8.00 | Pass |
| 11n-HT20 | MCS7 | 06 | 2437 | -14.55 | ≤ 8.00 | Pass |
| 11n-HT20 | MCS7 | 11 | 2462 | -13.25 | ≤ 8.00 | Pass |

802.11b - PKPSD

Channel 01 (2412MHz)

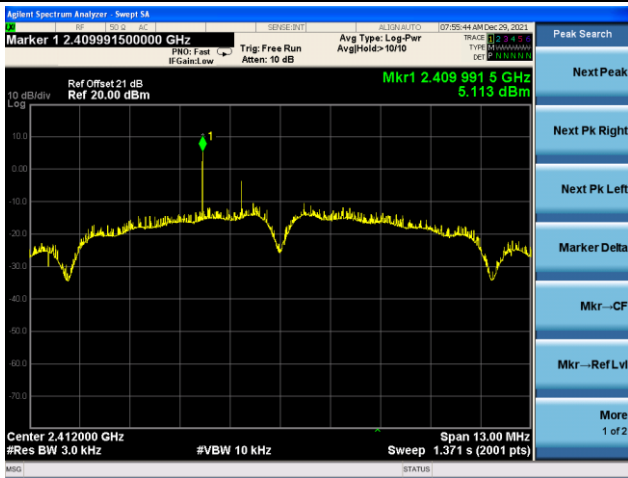

Channel 06 (2437MHz)

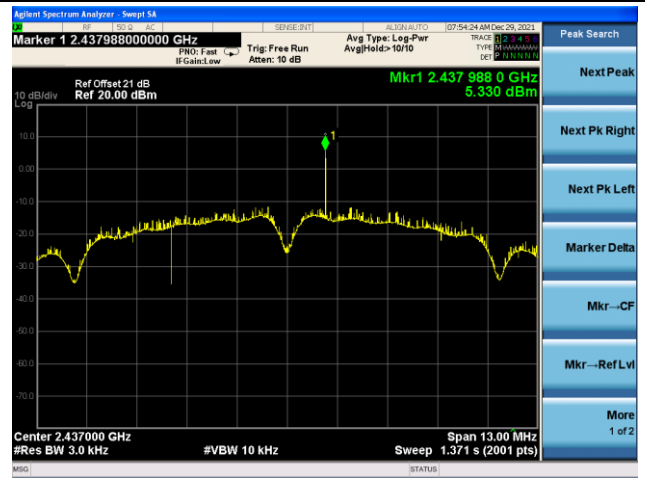

Channel 11 (2462MHz)

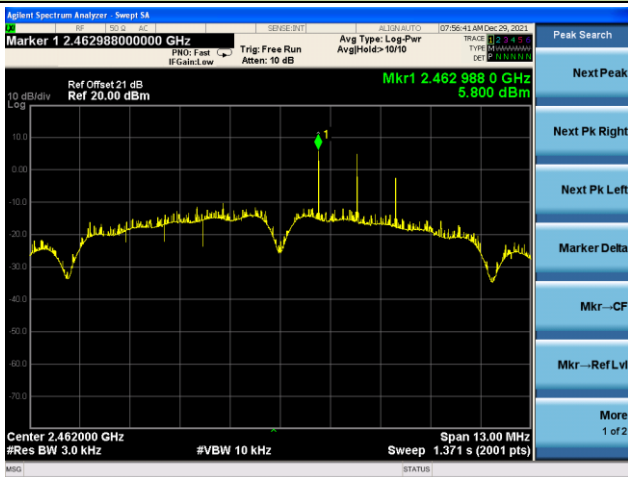

802.11g - PKPSD

Channel 01 (2412MHz)

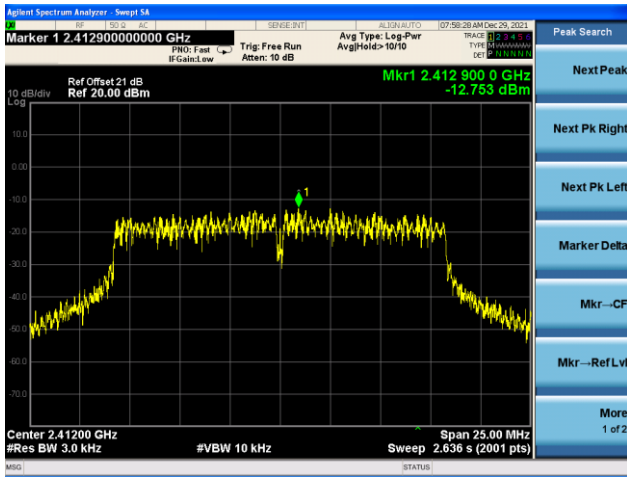

Channel 06 (2437MHz)

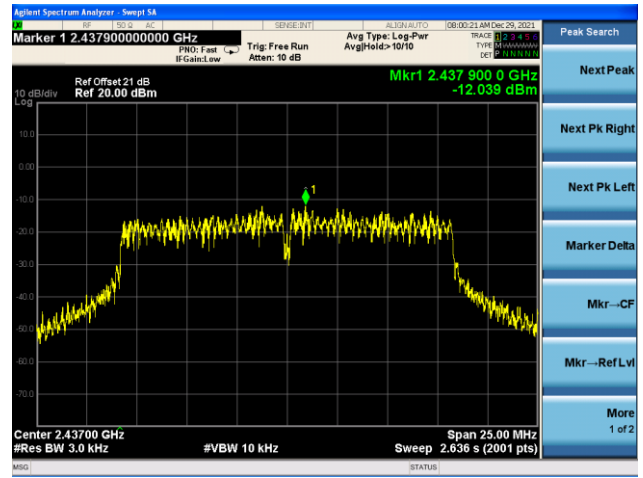

Channel 11 (2462MHz)

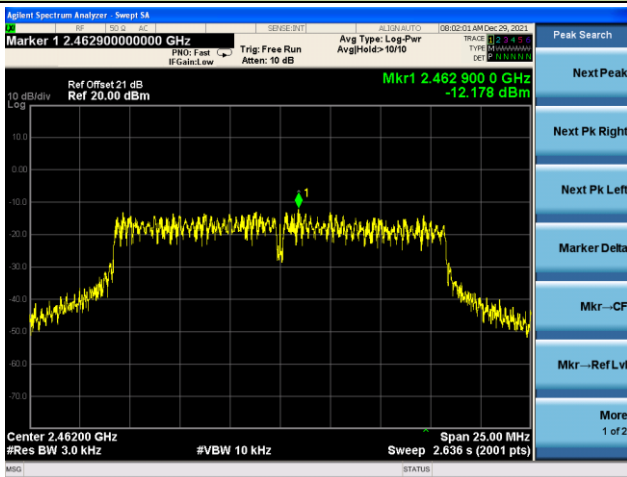

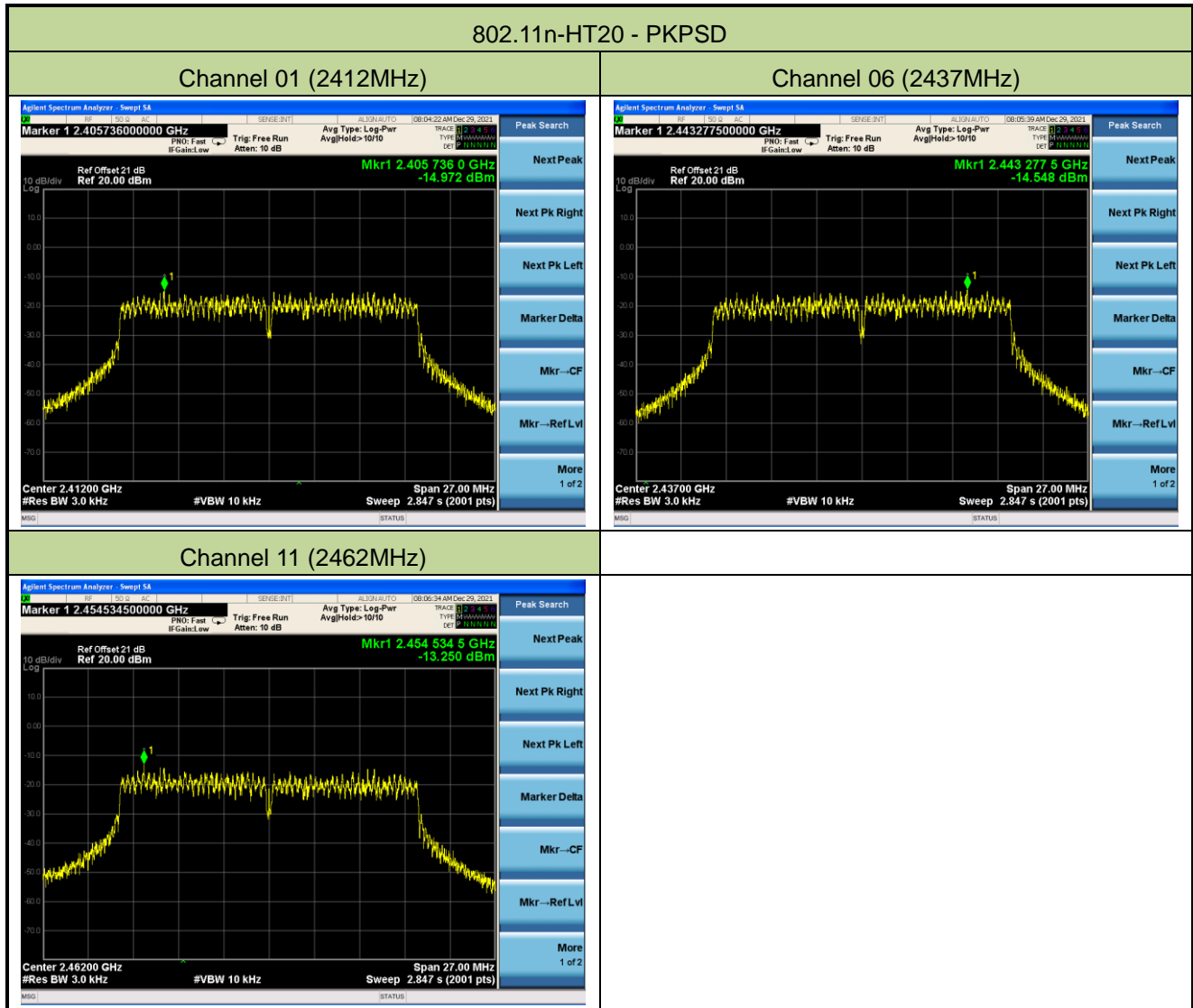

A.5 Conducted Band Edge and Out-of-Band Emissions Test Result

| | | | |
|-----------|-----------------------|---------------|-------------|
| Test Site | NS-TR2 | Test Engineer | Summer Tang |
| Test Date | 2021/12/21~2021/12/22 | | |

| Test Mode | Data Rate / MCS | Channel No. | Frequency (MHz) | Limit |
|-----------|-----------------|-------------|-----------------|-------|
| 11b | 1Mbps | 01 | 2412 | 20dBc |
| 11b | 1Mbps | 06 | 2437 | 20dBc |
| 11b | 1Mbps | 11 | 2462 | 20dBc |
| 11g | 6Mbps | 01 | 2412 | 20dBc |
| 11g | 6Mbps | 06 | 2437 | 20dBc |
| 11g | 6Mbps | 11 | 2462 | 20dBc |
| 11n-HT20 | MCS0 | 01 | 2412 | 20dBc |
| 11n-HT20 | MCS0 | 06 | 2437 | 20dBc |
| 11n-HT20 | MCS0 | 11 | 2462 | 20dBc |

