

# RF MEASUREMENT REPORT

---

**FCC ID:** HD5-EDA5S1  
**Applicant:** Honeywell International Inc  
Honeywell Safety and Productivity Solutions  
**Application Type:** Certification  
**Product:** Mobile Computer  
**Model No.:** EDA5S-1  
**Brand Name:** Honeywell  
**FCC Classification:** Unlicensed National Information Infrastructure (NII)  
**FCC Rule Part(s):** Part 15 Subpart E (Section 15.407)  
**Test Date:** December 15 ~ 27, 2021

**Reviewed By:**

\_\_\_\_\_  
Jame Yuan

**Approved By:**

\_\_\_\_\_  
Robin Wu



The test results relate only to the samples tested.

This equipment has been shown to be capable of compliance with the applicable technical standards as indicated in the measurement report and was tested in accordance with the measurement procedures specified in ANSI C63.10-2013. Test results reported herein relate only to the item(s) tested.

The test report shall not be reproduced except in full without the written approval of MRT Technology (Suzhou) Co., Ltd.

---

### Revision History

Report No.	Version	Description	Issue Date	Note
2111RSU064-U4	Rev. 01	Initial Report	01-06-2022	Valid

Note: EDA5S-1 is a variation on the existing EDA5S-0 (FCC ID: HD5-EDA5S0), added one LTE chipset, any others are the same. So EDA5S-1 reuse all conducted test data from test report 2111RSU063-U4, and the radiated spurious emission items were fully tested.

---

## CONTENTS

Description	Page
<b>1. General Information .....</b>	<b>6</b>
1.1. Applicant .....	6
1.2. Manufacturer .....	6
1.3. Testing Facility .....	6
1.4. Product Information.....	7
1.5. Radio Specification .....	7
1.6. Working Frequencies .....	8
<b>2. Test Configuration .....</b>	<b>9</b>
2.1. Test Mode.....	9
2.2. Test System Connection Diagram.....	9
2.3. Test Software .....	9
2.4. Applied Standards.....	10
2.5. Test Environment Condition .....	10
<b>3. Antenna Requirements .....</b>	<b>11</b>
<b>4. Measuring Instrument .....</b>	<b>12</b>
<b>5. Measurement Uncertainty.....</b>	<b>13</b>
<b>6. Test Result.....</b>	<b>14</b>
6.1. Summary.....	14
6.2. 26dB Bandwidth.....	15
6.2.1. Test Limit .....	15
6.2.2. Test Procedure.....	15
6.2.3. Test Setting .....	15
6.2.4. Test Setup .....	15
6.2.5. Test Result .....	15
6.3. 6dB Bandwidth.....	16
6.3.1. Test Limit .....	16
6.3.2. Test Procedure.....	16
6.3.3. Test Setting .....	16
6.3.4. Test Setup .....	16
6.3.5. Test Result .....	16
6.4. Output Power .....	17
6.4.1. Test Limit .....	17
6.4.2. Test Procedure.....	17
6.4.3. Test Setting .....	17
6.4.4. Test Setup .....	17

6.4.5.	Test Result .....	18
6.5.	Transmit Power Control .....	19
6.5.1.	Test Limit .....	19
6.5.2.	Test Procedure .....	19
6.5.3.	Test Setting .....	19
6.5.4.	Test Setup .....	19
6.5.5.	Test Result .....	19
6.6.	Power Spectral Density .....	20
6.6.1.	Test Limit .....	20
6.6.2.	Test Procedure .....	20
6.6.3.	Test Setting .....	20
6.6.4.	Test Setup .....	21
6.6.5.	Test Result .....	21
6.7.	Frequency Stability .....	22
6.7.1.	Test Limit .....	22
6.7.2.	Test Procedure .....	22
6.7.3.	Test Setup .....	23
6.7.4.	Test Result .....	23
6.8.	Radiated Spurious Emission .....	24
6.8.1.	Test Limit .....	24
6.8.2.	Test Procedure .....	24
6.8.3.	Test Setting .....	24
6.8.4.	Test Setup .....	26
6.8.5.	Test Result .....	26
6.9.	Radiated Restricted Band Edge .....	27
6.9.1.	Test Limit .....	27
6.9.2.	Test Procedure .....	28
6.9.3.	Test Setting .....	28
6.9.4.	Test Setup .....	29
6.9.5.	Test Result .....	29
6.10.	AC Conducted Emissions .....	30
6.10.1.	Test Limit .....	30
6.10.2.	Test Setup .....	30
6.10.3.	Test Result .....	30
<b>Appendix A – Test Result .....</b>		<b>31</b>
A.1	Duty Cycle Test Result .....	31
A.2	26dB & 99% Bandwidth Test Result .....	33
A.3	6dB Bandwidth Test Result .....	50
A.4	Output Power Test Result .....	55

---

A.5	Power Spectral Density Test Result.....	59
A.6	Frequency Stability Test Result.....	77
A.7	Radiated Spurious Emission Measurement Test Result.....	78
A.8	Radiated Restricted Band Edge Test Result.....	150
A.9	AC Conducted Emissions Test Result .....	256
<b>Appendix B – Test Setup Photograph .....</b>		<b>258</b>
<b>Appendix C – EUT Photograph .....</b>		<b>259</b>



#### 1.4. Product Information

Product Name	Mobile Computer
Model No.	EDA5S-1
Serial No.	Conducted Sample: 21294B506A Radiated Sample: 21294B3F94
Wi-Fi Specification	802.11a/b/g/n/ac
Bluetooth Specification	v5.0 dual mode
NFC Specification	Active, 13.56MHz
GNSS Specification	GPS/Galileo/BDS/GLONASS
3GPP Specification	GSM 850/1900 WCDMA Band 2/4/5 LTE Band 2/4/5/7/12/13/17/25/26/30/38/40/41/66
Working Voltage	3.85Vdc
Accessories	
Adapter	Model No.: ADS-12B-06 05010E Input Power: 100 - 240V ~ 50/60Hz, Max. 0.3A Output Power: 5VDC 2.0A
Rechargeable Li-ion Battery	Model No.: BAT-EDA5S Capacitance: 3060mAh 11.78Wh Rated Voltage: 3.85V
Remark: The information of EUT was provided by the manufacturer, and the accuracy of the information shall be the responsibility of the manufacturer.	

#### 1.5. Radio Specification

Frequency Range	For 802.11a/n-HT20/ac-VHT20: 5180~5240MHz, 5260~5320MHz, 5500~5720MHz, 5745~5825MHz For 802.11n-HT40/ac-VHT40: 5190~5230MHz, 5270~5310MHz, 5510~5710MHz, 5755~5795MHz For 802.11ac-VHT80: 5210MHz, 5290MHz, 5530MHz, 5610 MHz, 5690MHz, 5775MHz
Type of Modulation	802.11a/n/ac: OFDM
Data Rate	802.11a: 6/9/12/18/24/36/48/54Mbps 802.11n: up to 150Mbps 802.11ac: up to 433.3Mbps
Antenna Type	FPC Antenna
Antenna Gain	2.72dBi

Note: For other features of this EUT, test report will be issued separately.

### 1.6. Working Frequencies

#### 802.11a/n-HT20/ac-VHT20

Channel	Frequency	Channel	Frequency	Channel	Frequency
36	5180 MHz	40	5200 MHz	44	5220 MHz
48	5240 MHz	52	5260 MHz	56	5280 MHz
60	5300 MHz	64	5320 MHz	100	5500 MHz
104	5520 MHz	108	5540 MHz	112	5560 MHz
116	5580 MHz	120	5600 MHz	124	5620 MHz
128	5640 MHz	132	5660 MHz	136	5680 MHz
140	5700 MHz	144	5720 MHz	149	5745 MHz
153	5765 MHz	157	5785 MHz	161	5805 MHz
165	5825 MHz	--	--	--	--

#### 802.11n-HT40/ac-VHT40

Channel	Frequency	Channel	Frequency	Channel	Frequency
38	5190 MHz	46	5230 MHz	54	5270 MHz
62	5310 MHz	102	5510 MHz	110	5550 MHz
118	5590 MHz	126	5630 MHz	134	5670 MHz
142	5710 MHz	151	5755 MHz	159	5795 MHz

#### 802.11ac-VHT80

Channel	Frequency	Channel	Frequency	Channel	Frequency
42	5210 MHz	58	5290 MHz	106	5530 MHz
122	5610 MHz	138	5690 MHz	155	5775 MHz



## 2. Test Configuration

### 2.1. Test Mode

Mode 1: Transmit by 802.11a (24Mbps)
Mode 2: Transmit by 802.11n-HT20 (MCS7)
Mode 3: Transmit by 802.11n-HT40 (MCS0)
Mode 4: Transmit by 802.11ac-VHT20 (MCS7)
Mode 5: Transmit by 802.11ac-VHT40 (MCS0)
Mode 6: Transmit by 802.11ac-VHT80 (MCS0)

### 2.2. Test System Connection Diagram

The device was tested per the guidance ANSI C63.10: 2013 was used to reference the appropriate EUT setup for radiated emissions testing and AC line conducted testing.

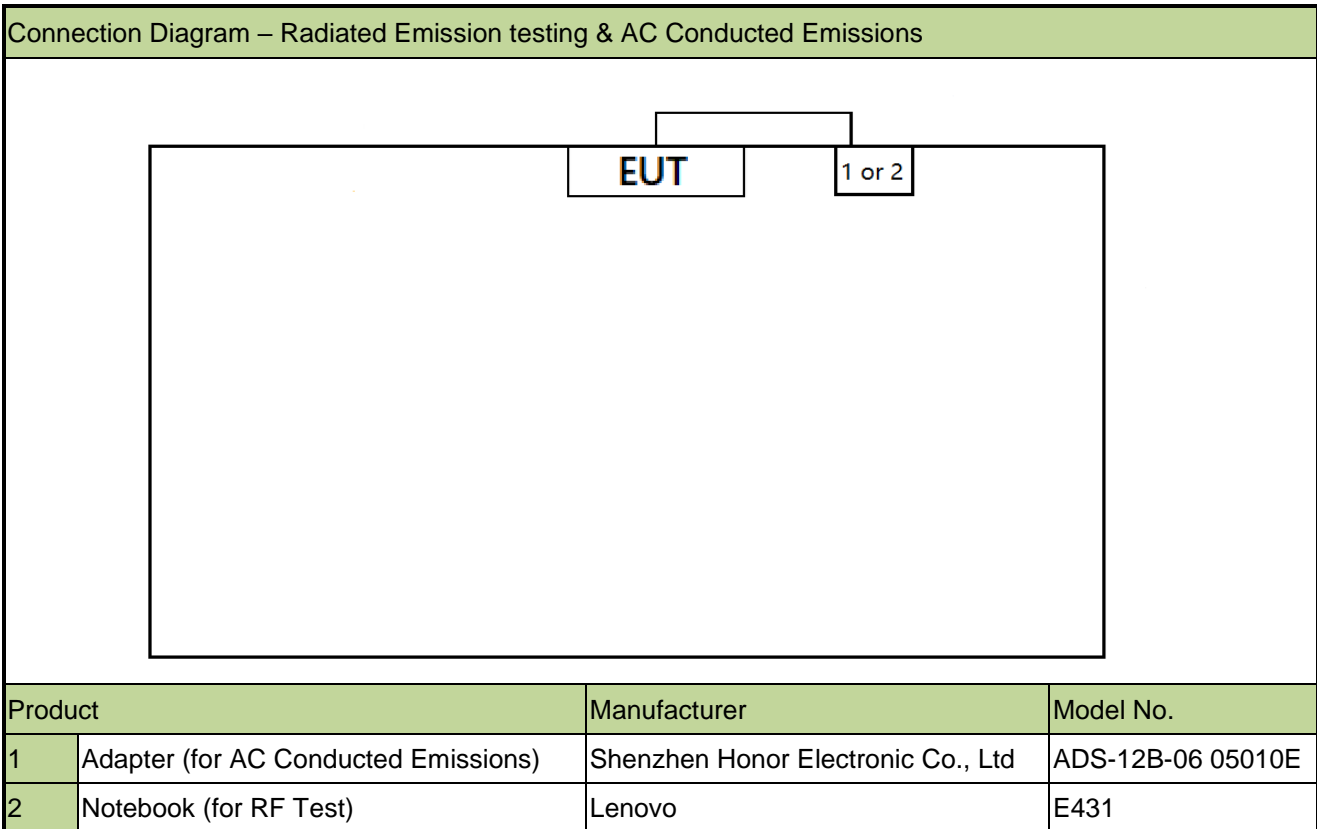

### 2.3. Test Software

The test utility software used during testing was “QRCT”, and the version was 3.0.268.0.

#### 2.4. Applied Standards

According to the specifications of the manufacturer, the EUT must comply with the requirements of the following standards:

- FCC Part 15.407
- KDB 789033 D02v02r01
- ANSI C63.10-2013

#### 2.5. Test Environment Condition

Ambient Temperature	15 ~ 35°C
Relative Humidity	20 ~ 75%RH

### 3. Antenna Requirements

#### Excerpt from §15.203 of the FCC Rules/Regulations:

“An intentional radiator antenna shall be designed to ensure that no antenna other than that furnished by the responsible party can be used with the device. The use of a permanently attached antenna or of an antenna that uses a unique coupling to the intentional radiator shall be considered sufficient to comply with the provisions of this section.”

- The antenna of the device is **permanently attached**.
- There are no provisions for connection to an external antenna.

#### **Conclusion:**

The unit complies with the requirement of §15.203.

#### 4. Measuring Instrument

Instrument	Manufacturer	Model No.	Asset No.	Cali. Interval	Cali. Due Date	Test Site
Horn Antenna	Schwarzbeck	BBHA 9170	MRTSUE06292	1 year	2022/10/20	NS-AC1
Anechoic Chamber	BOOMWAVE	NS-AC1	MRTSUE06496	1 year	2022/7/24	NS-AC1
Horn Antenna	Schwarzbeck	BBHA 9120D	MRTSUE06572	1 year	2022/3/14	NS-AC1
TRILOG Antenna	Schwarzbeck	VULB 9162	MRTSUE06573	1 year	2022/6/29	NS-AC1
Loop Antenna	Schwarzbeck	FMZB 1519 B	MRTSUE06937	1 year	2022/3/9	SIP-AC1
Preamplifier	Schwarzbeck	BBV 9718	MRTSUE06574	1 year	2022/7/12	NS-AC1
EMI Test Receiver	R&S	ESR3	MRTSUE06575	1 year	2022/6/27	NS-AC1
Thermohygrometer	DELI	NO.8813	MRTSUE06588	1 year	2022/6/30	NS-AC1
Preamplifier	EMCI	EMC184045SE	MRTSUE06641	1 year	2022/1/14	NS-AC1
Signal Analyzer	Agilent	N9010A	MRTSUE06195	1 year	2022/3/17	NS-AC1/NS-TR2
Signal Analyzer	Keysight	N9020A	MRTSUE10065	1 year	2022/6/17	NS-AC1/NS-TR2
Shielding Room	BOOMWAVE	NS-SR2	MRTSUE06551	/	/	NS-SR2
EMI Test Receiver	R&S	ESL3	MRTSUE06576	1 year	2022/6/27	NS-SR2
Two-Line V-Network	R&S	ENV216	MRTSUE06577	1 year	2022/7/4	NS-SR2
Two-Line V-Network	R&S	ENV216	MRTSUE06578	1 year	2022/7/4	NS-SR2
ISN	R&S	ENY81	MRTSUE06579	1 year	2022/7/4	NS-SR2
ISN	R&S	ENY81-CA6	MRTSUE06580	1 year	2022/6/15	NS-SR2
Thermohygrometer	DELI	NO.8813	MRTSUE06587	1 year	2022/6/30	NS-SR2
USB Power Sensor	Keysight	U2021XA	MRTSUE06581	1 year	2022/8/15	NS-TR2
Thermohygrometer	DELI	NO.8813	MRTSUE06783	1 year	2022/5/9	NS-TR2
Temperature Chamber	OUKE	OK-TH-100C	MRTSUE06899	1 year	2022/11/1	NS-TR2

Software	Version	Function
EMI Software	V3	EMI Test Software

Note: Test site (NS-AC1 & NS-SR2 & NS-TR2) belong to MRT Shenzhen Laboratory, Test site (SIP-AC1) belong to MRT Suzhou Laboratory.

## 5. Measurement Uncertainty

Where relevant, the following test uncertainty levels have been estimated for tests performed on the EUT as specified in CISPR 16-4-2. This uncertainty represents an expanded uncertainty expressed at approximately the 95% confidence level using a coverage factor of  $k = 2$ .

<b>AC Conducted Emission Measurement</b>
Measurement Uncertainty for a Level of Confidence of 95% ( $U=2Uc(y)$ ): 9kHz~150kHz: 3.74dB 150kHz~30MHz: 3.44dB
<b>Radiated Emission Measurement</b>
Measurement Uncertainty for a Level of Confidence of 95% ( $U=2Uc(y)$ ): Horizontal: 30MHz~300MHz: 5.04dB 300MHz~1GHz: 4.95dB 1GHz~40GHz: 6.40dB Vertical: 30MHz~300MHz: 5.24dB 300MHz~1GHz: 6.03dB 1GHz~40GHz: 6.40dB
<b>Spurious Emissions, Conducted</b>
Measuring Uncertainty for a Level of Confidence of 95% ( $U=2Uc(y)$ ): 0.78dB
<b>Output Power</b>
Measuring Uncertainty for a Level of Confidence of 95% ( $U=2Uc(y)$ ): 1.13dB
<b>Power Spectrum Density</b>
Measuring Uncertainty for a Level of Confidence of 95% ( $U=2Uc(y)$ ): 1.15dB
<b>Occupied Bandwidth</b>
Measuring Uncertainty for a Level of Confidence of 95% ( $U=2Uc(y)$ ): 0.28%

## 6. Test Result

### 6.1. Summary

FCC Section(s)	Test Description	Test Condition	Verdict
15.407(a)	26dB Bandwidth	Conducted	Pass
15.407(e)	6dB Bandwidth		Pass
15.407(a)(1)(iv), (2), (3)(i)	Maximum Conducted Output Power		Pass
15.407(h)(1)	Transmit Power Control		N/A
15.407(a)(1)(iv), (2), (3)(i), (12)	Peak Power Spectral Density		Pass
15.407(g)	Frequency Stability		Pass
15.407(b)(1), (2), (3), (4)(i)	Undesirable Emissions		Pass
15.205, 15.209 15.407(b)(9), (10), (11)	General Field Strength Limits (Restricted Bands and Radiated Emission Limits)	Radiated	Pass
15.207	AC Conducted Emissions 150kHz - 30MHz	Line Conducted	Pass

**Remark:**

- The analyzer plots shown in this section were all taken with a correction table loaded into the analyzer. The correction table was used to account for the losses of the cables and attenuators used as part of the system to connect the EUT to the analyzer at all frequencies of interest.
- For radiated emission test, every axis (X, Y, Z) was also verified. The test results shown in the following sections represent the worst-case emissions.
- “N/A” means that the test item is not applicable, and the detailed information refers to relevant section.

## 6.2. 26dB Bandwidth

### 6.2.1. Test Limit

N/A

### 6.2.2. Test Procedure

KDB 789033 D02v02r01- Section C.1

### 6.2.3. Test Setting

1. The analyzers' automatic bandwidth measurement capability was used to perform the 26dB bandwidth measurement. The "X" dB bandwidth parameter was set to  $X = 26$ . The automatic bandwidth measurement function also has the capability of simultaneously measuring the 99% occupied bandwidth. The bandwidth measurement was not influenced by any intermediated power nulls in the fundamental emission.
2. RBW = approximately 1% of the emission bandwidth.
3. VBW  $\geq 3 \times$  RBW.
4. Detector = Peak.
5. Trace mode = max hold.

### 6.2.4. Test Setup

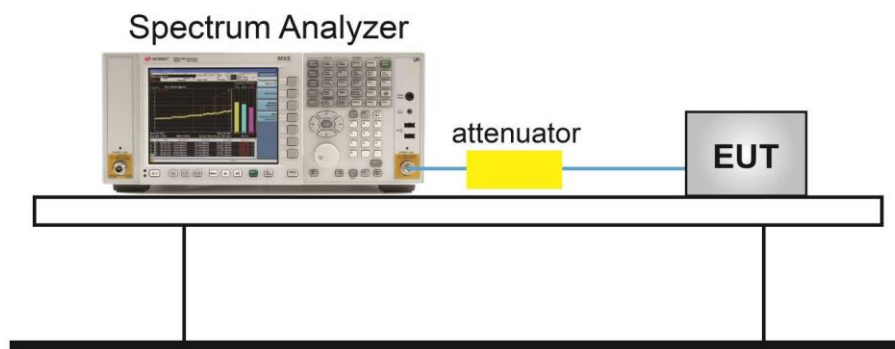

### 6.2.5. Test Result

Refer to Appendix A.2.

### 6.3. 6dB Bandwidth

#### 6.3.1. Test Limit

The minimum 6dB bandwidth shall be at least 500 kHz.

#### 6.3.2. Test Procedure

KDB 789033 D02v02r01- Section C.2

#### 6.3.3. Test Setting

1. Set center frequency to the nominal EUT channel center frequency.
2. RBW = 100 kHz.
3. VBW 3 × RBW.
4. Detector = Peak.
5. Trace mode = max hold.
6. Sweep = auto couple.
7. Allow the trace to stabilize.
8. Measure the maximum width of the emission that is constrained by the frequencies associated with the two outermost amplitude points (upper and lower frequencies) that are attenuated by 6 dB relative to the maximum level measured in the fundamental emission.

#### 6.3.4. Test Setup

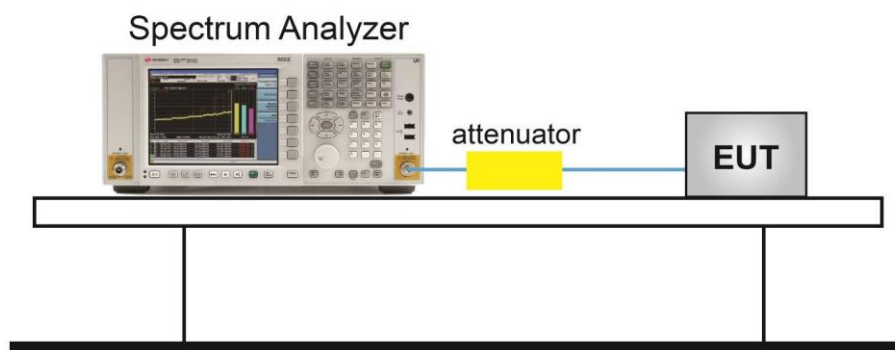

#### 6.3.5. Test Result

Refer to Appendix A.3.



## 6.4. Output Power

### 6.4.1. Test Limit

For client devices in the 5.15-5.25 GHz band, the maximum conducted output power over the frequency band of operation shall not exceed 250 mW provided the maximum antenna gain does not exceed 6 dBi.

For the 5.25-5.35 GHz and 5.47-5.725 GHz bands, the maximum conducted output power over the frequency bands of operation shall not exceed the lesser of 250 mW or  $11 \text{ dBm} + 10 \log B$ , where B is the 26 dB emission bandwidth in megahertz.

For the band 5.725-5.85 GHz, the maximum conducted output power over the frequency band of operation shall not exceed 1 W (30dBm).

If transmitting antennas of directional gain greater than 6dBi are used, the maximum conducted output power shall be reduced by the amount in dB that the directional gain of the antenna exceeds 6dBi.

### 6.4.2. Test Procedure

KDB 789033D02v02r01- Section E)3)b) Method PM-G

### 6.4.3. Test Setting

#### Average Power Measurement

Average power measurements were performed only when the EUT was transmitting at its maximum power control level using a broadband power meter with a pulse sensor. The power meter implemented triggering and gating capabilities which were set up such that power measurements were recorded only during the ON time of the transmitter.

### 6.4.4. Test Setup

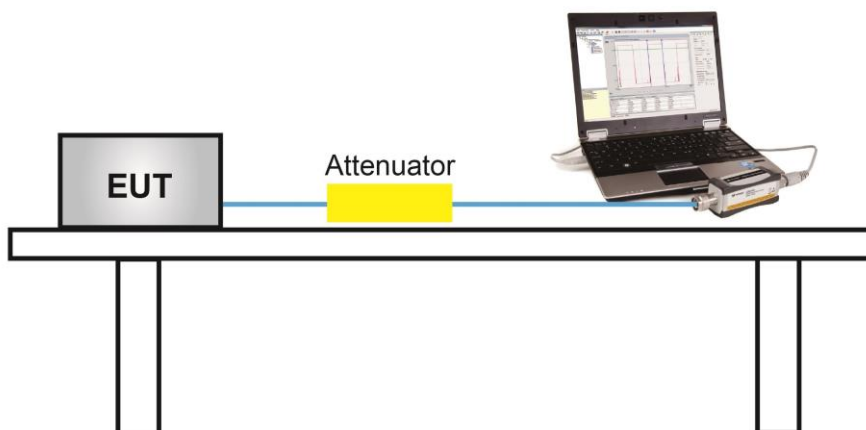

#### **6.4.5. Test Result**

Refer to Appendix A.4.

## 6.5. Transmit Power Control

### 6.5.1. Test Limit

The U-NII device is required to have the capability to operate at least 6 dB below the mean EIRP value of 30 dBm.

### 6.5.2. Test Procedure

KDB 789033 D02v01- Section E)3)b) Method PM-G

### 6.5.3. Test Setting

Average power measurements were performed only when the EUT was transmitting at its maximum power control level using a broadband power meter with a pulse sensor. The power meter implemented triggering and gating capabilities which were set up such that power measurements were recorded only during the ON time of the transmitter. The trace was averaged over 100 traces to obtain the final measured average power.

### 6.5.4. Test Setup

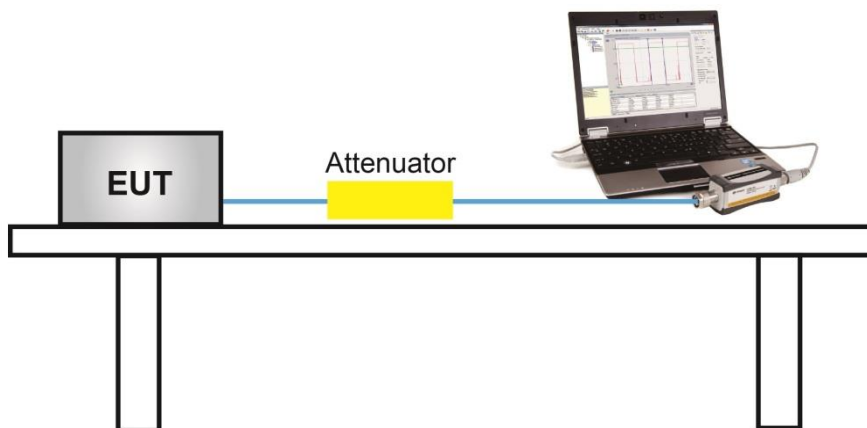

### 6.5.5. Test Result

A TPC mechanism is not required for systems with an e.i.r.p. of less than 500 mW.

## 6.6. Power Spectral Density

### 6.6.1. Test Limit

For client devices in the 5.15-5.25 GHz band, the maximum power spectral density shall not exceed 11 dBm in any 1 megahertz band.

For the 5.25-5.35 GHz and 5.47-5.725 GHz bands, the maximum power spectral density shall not exceed 11 dBm in any 1 megahertz band.

For the band 5.725-5.85 GHz, the maximum power spectral density shall not exceed 30 dBm in any 500-kHz band.

If transmitting antennas of directional gain greater than 6dBi are used, the peak power spectral density shall be reduced by the amount in dB that the directional gain of the antenna exceeds 6dBi.

### 6.6.2. Test Procedure

KDB 789033 D02v02r01-SectionF

### 6.6.3. Test Setting

1. Analyzer was set to the center frequency of the UNII channel under investigation
2. Span was set to encompass the entire 26dB EBW of the signal
3. RBW = 1MHz (510kHz, if measurement bandwidth of Maximum PSD is specified in 500 kHz), VBW = 3MHz
4. Number of sweep points  $\geq 2 \times (\text{span} / \text{RBW})$
5. Detector = power averaging (Average)
6. Sweep time = auto
7. Trigger = free run
8. Use the peak search function on the instrument to find the peak of the spectrum and record its value.
9. Add  $10 \cdot \log(1/x)$ , where x is the duty cycle, to the measured power in order to compute the average power during the actual transmission times (because the measurement represents an average over both the on and off times of the transmission). For example, add  $10 \cdot \log(1/0.25) = 6$  dB if the duty cycle is 25 percent.

#### 6.6.4. Test Setup

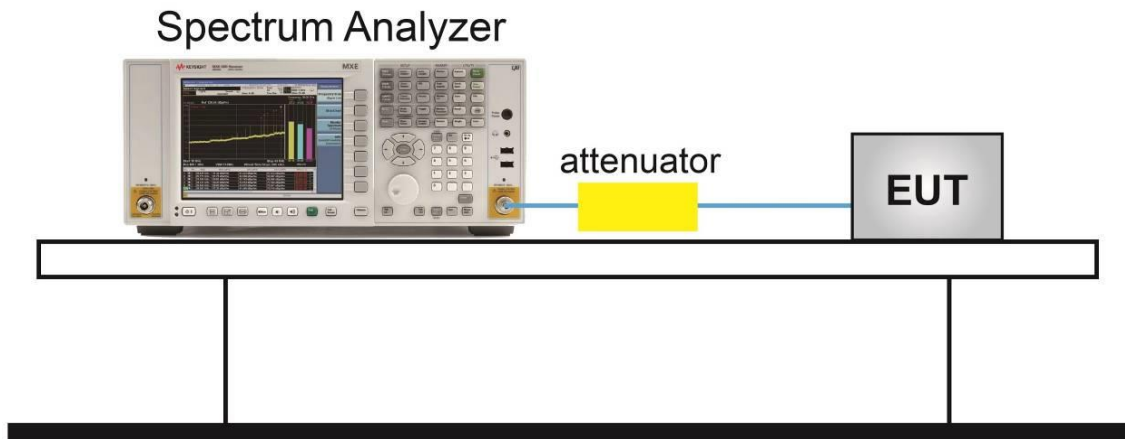

#### 6.6.5. Test Result

Refer to Appendix A.5.

## **6.7. Frequency Stability**

### **6.7.1. Test Limit**

Manufactures of U-NII devices are responsible for ensuring frequency stability such that an emission is maintained within the band of operation under all conditions of normal operation as specified in the user's manual.

### **6.7.2. Test Procedure**

#### **Frequency Stability Under Temperature Variations:**

The equipment under test was connected to an external AC or DC power supply and input rated voltage. RF output was connected to a frequency counter or spectrum analyzer via feed through attenuators. The EUT was placed inside the temperature chamber. Set the spectrum analyzer RBW low enough to obtain the desired frequency resolution and measure EUT 20°C operating frequency as reference frequency. Turn EUT off and set the chamber temperature to highest. After the temperature stabilized for approximately 30 minutes recorded the frequency. Repeat step measure with 10°C decreased per stage until the lowest temperature reached.

#### **Frequency Stability Under Voltage Variations:**

Set chamber temperature to 20°C. Use a variable AC power supply / DC power source to power the EUT and set the voltage to rated voltage. Set the spectrum analyzer RBW low enough to obtain the desired frequency resolution and recorded the frequency.

Reduce the input voltage to specify extreme voltage variation ( $\pm 15\%$ ) and endpoint, record the maximum frequency change.

### 6.7.3. Test Setup

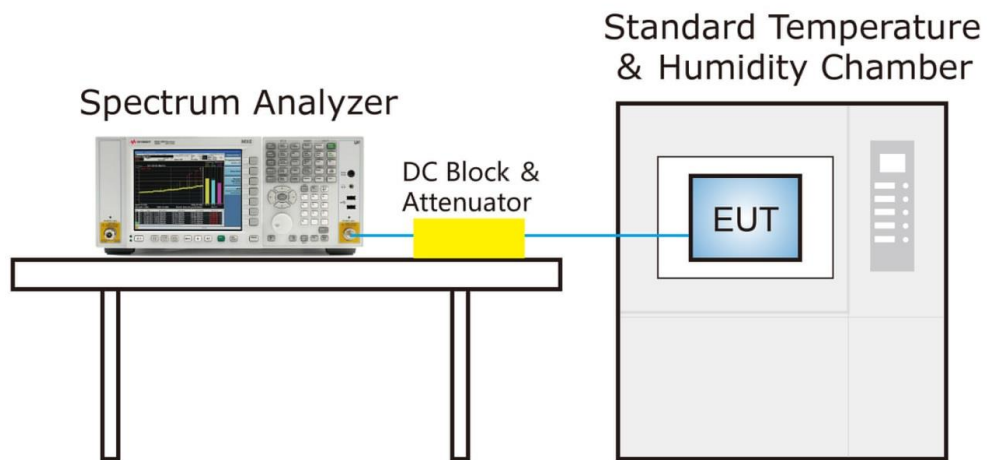

### 6.7.4. Test Result

Refer to Appendix A.5.

## 6.8. Radiated Spurious Emission

### 6.8.1. Test Limit

All out of band emissions appearing in a restricted band as specified in Section 15.205 of the Title 47 CFR must not exceed the limits shown in Table per Section 15.209.

FCC Part 15 Subpart C Paragraph 15.209		
Frequency [MHz]	Field Strength [uV/m]	Measured Distance [Meters]
0.009 - 0.490	2400/F (kHz)	300
0.490 - 1.705	24000/F (kHz)	30
1.705 - 30	30	30
30 - 88	100	3
88 - 216	150	3
216 - 960	200	3
Above 960	500	3

### 6.8.2. Test Procedure

KDB 789033 D02v02r01- Section G

### 6.8.3. Test Setting

**Table 1 - RBW as a function of frequency**

Frequency	RBW
9 ~ 150 kHz	200 ~ 300 Hz
0.15 ~ 30 MHz	9 ~ 10 kHz
30 ~ 1000 MHz	100 ~ 120 kHz
> 1000MHz	1MHz



**Quasi-Peak Measurements below 1GHz**

1. Analyzer center frequency was set to the frequency of the radiated spurious emission of interest
2. Span was set greater than 1MHz
3. RBW = as specified in Table 1
4. Detector = CISPR quasi-peak
5. Sweep time = auto couple
6. Trace was allowed to stabilize

**Peak Measurements above 1GHz**

1. Analyzer center frequency was set to the frequency of the radiated spurious emission of interest
2. RBW = 1MHz
3. VBW = 3MHz
4. Detector = peak
5. Sweep time = auto couple
6. Trace mode = max hold
7. Trace was allowed to stabilize

**Average Measurements above 1GHz (Method VB)**

1. Analyzer center frequency was set to the frequency of the radiated spurious emission of interest
2. RBW = 1MHz
3. VBW; If the EUT is configured to transmit with duty cycle  $\geq 98\%$ , set VBW = 10 Hz.  
If the EUT duty cycle is  $< 98\%$ , set VBW  $\geq 1/T$ . T is the minimum transmission duration.
4. Detector = Peak
5. Sweep time = auto
6. Trace mode = max hold
7. Trace was allowed to stabilize

### 6.8.4. Test Setup

Below 1GHz Test Setup:

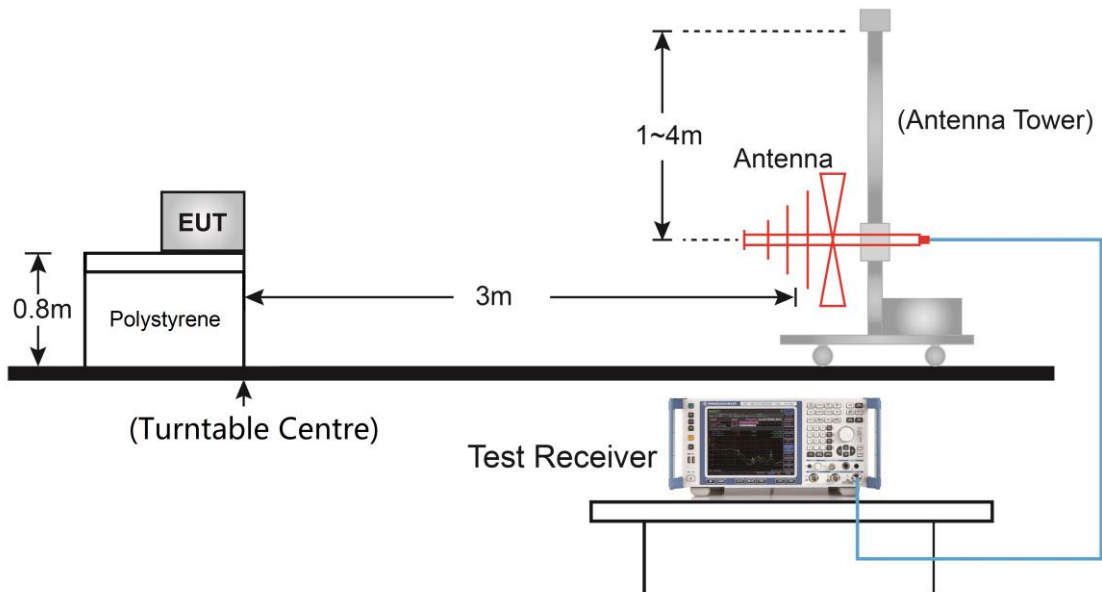

Above 1GHz Test Setup:

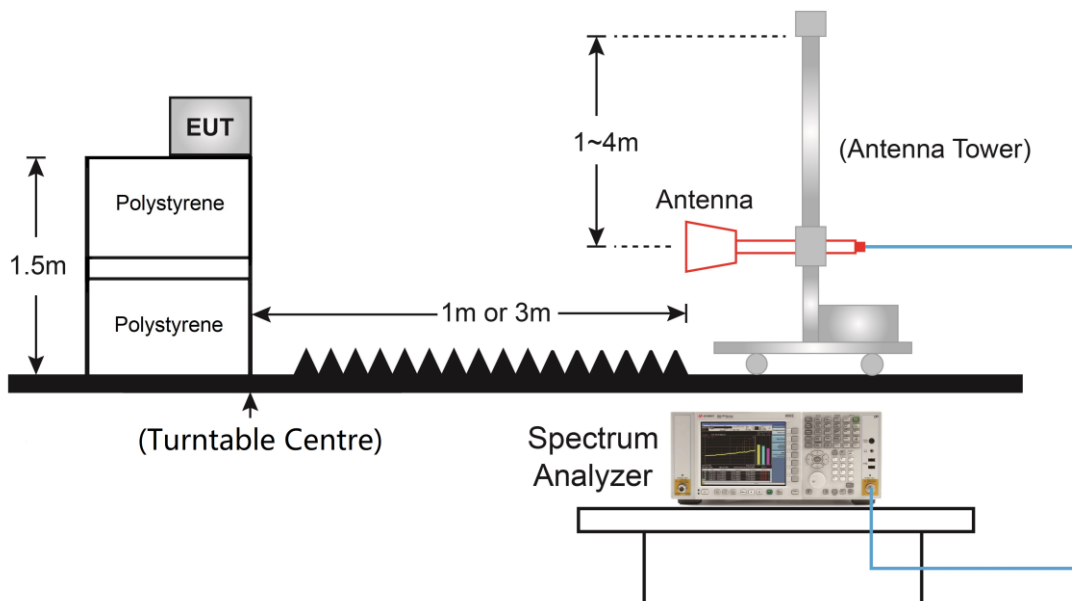

### 6.8.5. Test Result

Refer to Appendix A.6.

## 6.9. Radiated Restricted Band Edge

### 6.9.1. Test Limit

#### For 15.205 requirement:

Radiated emissions which fall in the restricted bands, as defined in Section 15.205(a) of FCC part 15, must also comply with the radiated emission limits specified in Section 15.209(a).

Frequency (MHz)	Frequency (MHz)	Frequency (MHz)	Frequency (GHz)
0.090 - 0.110	16.42 - 16.423	399.9 - 410	4.5 - 5.15
<sup>1</sup> 0.495 - 0.505	16.69475 - 16.69525	608 - 614	5.35 - 5.46
2.1735 - 2.1905	16.80425 - 16.80475	960 - 1240	7.25 - 7.75
4.125 - 4.128	25.5 - 25.67	1300 - 1427	8.025 - 8.5
4.17725 - 4.17775	37.5 - 38.25	1435 - 1626.5	9.0 - 9.2
4.20725 - 4.20775	73 - 74.6	1645.5 - 1646.5	9.3 - 9.5
6.215 - 6.218	74.8 - 75.2	1660 - 1710	10.6 - 12.7
6.26775 - 6.26825	108 - 121.94	1718.8 - 1722.2	13.25 - 13.4
6.31175 - 6.31225	123 - 138	2200 - 2300	14.47 - 14.5
8.291 - 8.294	149.9 - 150.05	2310 - 2390	15.35 - 16.2
8.362 - 8.366	156.52475 - 156.52525	2483.5 - 2500	17.7 - 21.4
8.37625 - 8.38675	156.7 - 156.9	2690 - 2900	22.01 - 23.12
8.41425 - 8.41475	162.0125 - 167.17	3260 - 3267	23.6 - 24.0
12.29 - 12.293	167.72 - 173.2	3332 - 3339	31.2 - 31.8
12.51975 - 12.52025	240 - 285	3345.8 - 3358	36.43 - 36.5
12.57675 - 12.57725	322 - 335.4	3600 - 4400	( <sup>2</sup> )
13.36 - 13.41	--	--	--

For 15.407(b) requirement:

For transmitters operating in the 5.15-5.25 GHz band: All emissions outside of the 5.15-5.35 GHz band shall not exceed an e.i.r.p. of -27 dBm/MHz.

For transmitters operating in the 5.25-5.35 GHz band: All emissions outside of the 5.15-5.35 GHz band shall not exceed an e.i.r.p. of -27 dBm/MHz.

For transmitters operating in the 5.47-5.725 GHz band: All emissions outside of the 5.47-5.725 GHz band shall not exceed an e.i.r.p. of -27 dBm/MHz.

For transmitters operating in the 5.725-5.85 GHz band: All emissions shall be limited to a level of -27 dBm/MHz at 75 MHz or more above or below the band edge increasing linearly to 10 dBm/MHz at 25 MHz above or below the band edge, and from 25 MHz above or below the band edge increasing linearly to a level

of 15.6 dBm/MHz at 5 MHz above or below the band edge, and from 5 MHz above or below the band edge increasing linearly to a level of 27 dBm/MHz at the band edge.

Refer to KDB 789033 D02v02r01 G)2)c), as specified in § 15.407(b), emissions above 1000 MHz that are outside of the restricted bands are subject to a maximum emission limit of -27 dBm/MHz (or -17 dBm/MHz as specified in § 15.407(b)(4)). However, an out-of-band emission that complies with both the peak and average limits of § 15.209 is not required to satisfy the -27 dBm/MHz or -17 dBm/MHz maximum emission limit.

All out of band emissions appearing in a restricted band as specified in Section 15.205 of the Title 47CFR must not exceed the limits shown in Table per Section 15.209.

FCC Part 15 Subpart C Paragraph 15.209		
Frequency [MHz]	Field Strength [uV/m]	Measured Distance [Meters]
0.009 - 0.490	2400/F (kHz)	300
0.490 - 1.705	24000/F (kHz)	30
1.705 - 30	30	30
30 - 88	100	3
88 - 216	150	3
216 - 960	200	3
Above 960	500	3

**6.9.2. Test Procedure**

KDB 789033 D02v02r01- Section G

**6.9.3. Test Setting**

**Peak Measurements above 1GHz**

1. Analyzer center frequency was set to the frequency of the radiated spurious emission of interest
2. RBW = 1MHz
3. VBW = 3MHz
4. Detector = Peak
5. Sweep time = Auto couple
6. Trace mode = Max hold
7. Trace was allowed to stabilize

### Average Measurements above 1GHz (Method VB)

1. Analyzer center frequency was set to the frequency of the radiated spurious emission of interest
2. RBW = 1MHz
3. VBW; if the EUT is configured to transmit with duty cycle  $\geq 98\%$ , set VBW = 10Hz
4. If the EUT duty cycle is  $< 98\%$ , set VBW  $\geq 1/T$ . T is the minimum transmission duration
5. Detector = Peak
6. Sweep time = Auto
7. Trace mode = Max hold
8. Trace was allowed to stabilize

#### 6.9.4. Test Setup

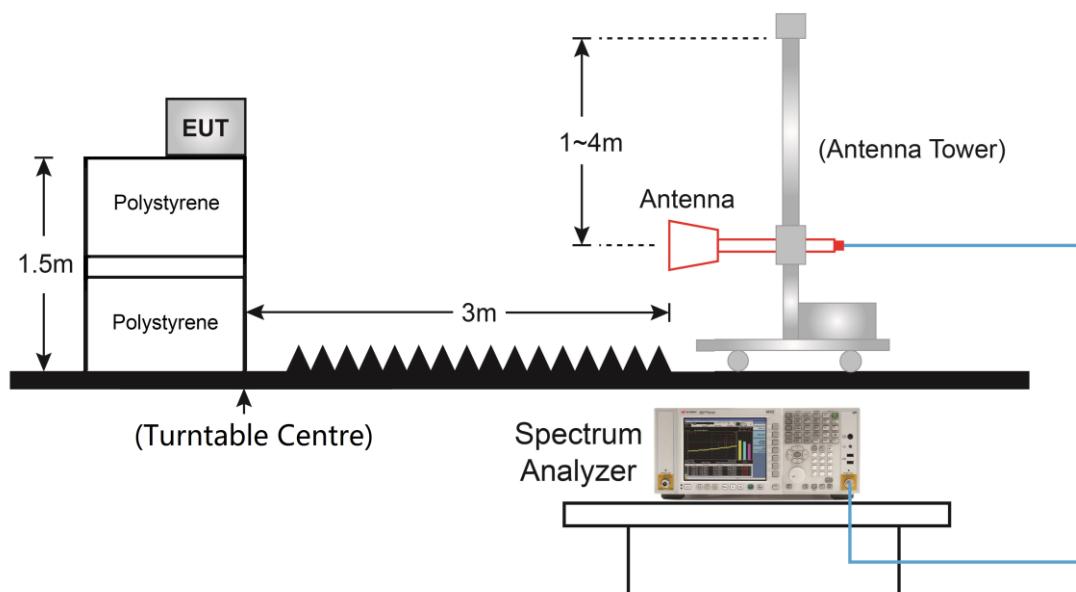

#### 6.9.5. Test Result

Refer to Appendix A.7.

## 6.10. AC Conducted Emissions

### 6.10.1. Test Limit

FCC Part 15.207 Limits		
Frequency (MHz)	QP (dBuV)	AV (dBuV)
0.15 - 0.50	66 - 56	56 - 46
0.50 - 5.0	56	46
5.0 - 30	60	50

Note 1: The lower limit shall apply at the transition frequencies.

Note 2: The limit decreases linearly with the logarithm of the frequency in the range 0.15MHz to 0.5MHz.

### 6.10.2. Test Setup

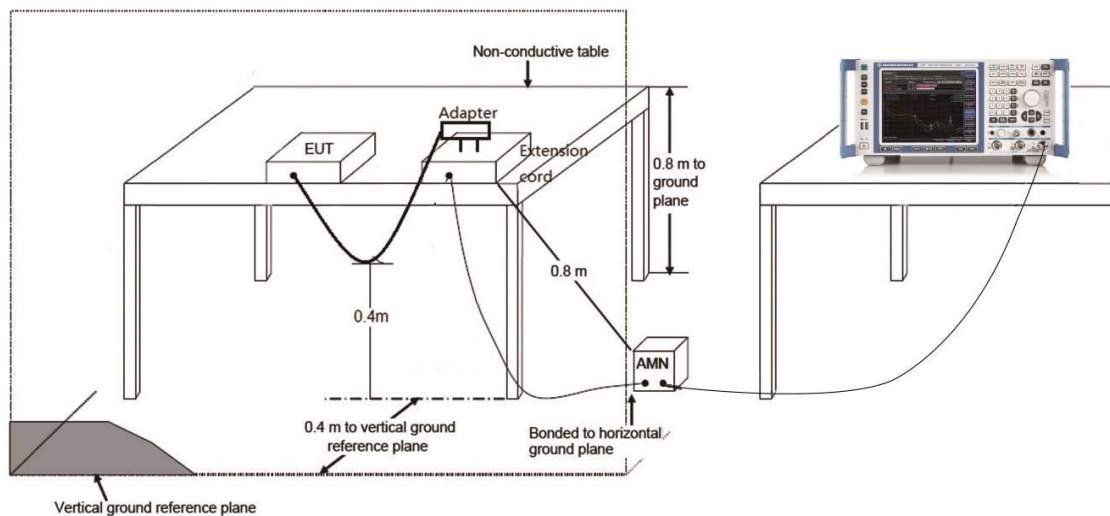

### 6.10.3. Test Result

Refer to Appendix A.8.

## Appendix A – Test Result

### A.1 Duty Cycle Test Result

Test Site	NS-TR2	Test Engineer	Summer Tang
Test Date	2021/12/15		

Test Mode	Duty Cycle	Test Mode	Duty Cycle
802.11a	93.49%	802.11ac-VHT20	86.03%
802.11n-HT20	86.17%	802.11ac-VHT40	95.88%
802.11n-HT40	95.37%	802.1ac-VHT80	92.60%

Duty Cycle (T = Transmission Duration)

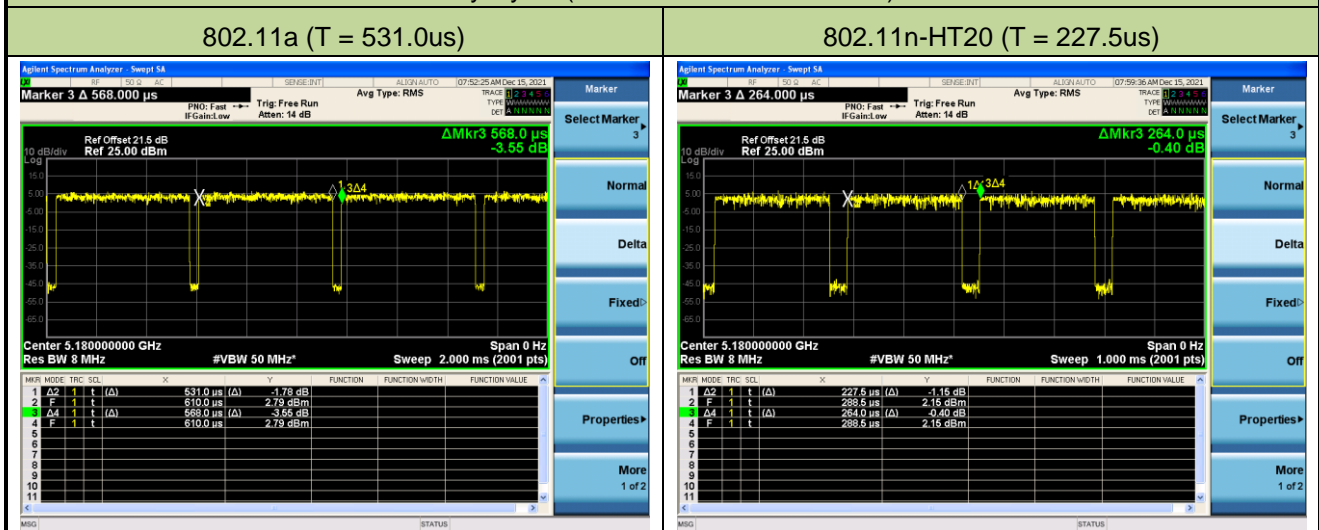

Duty Cycle (T = Transmission Duration)

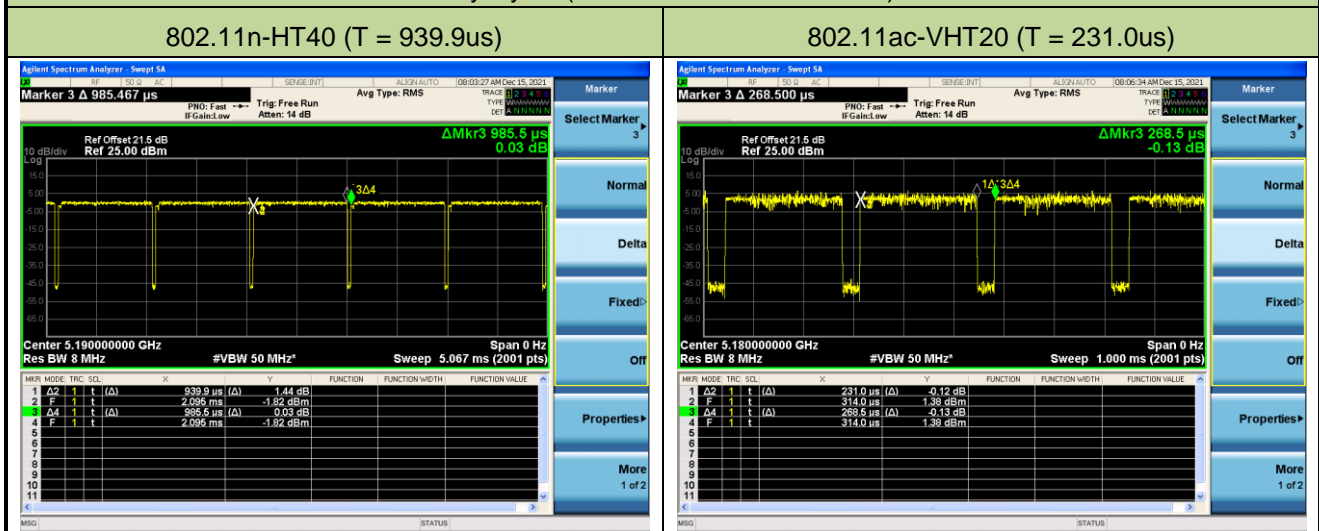

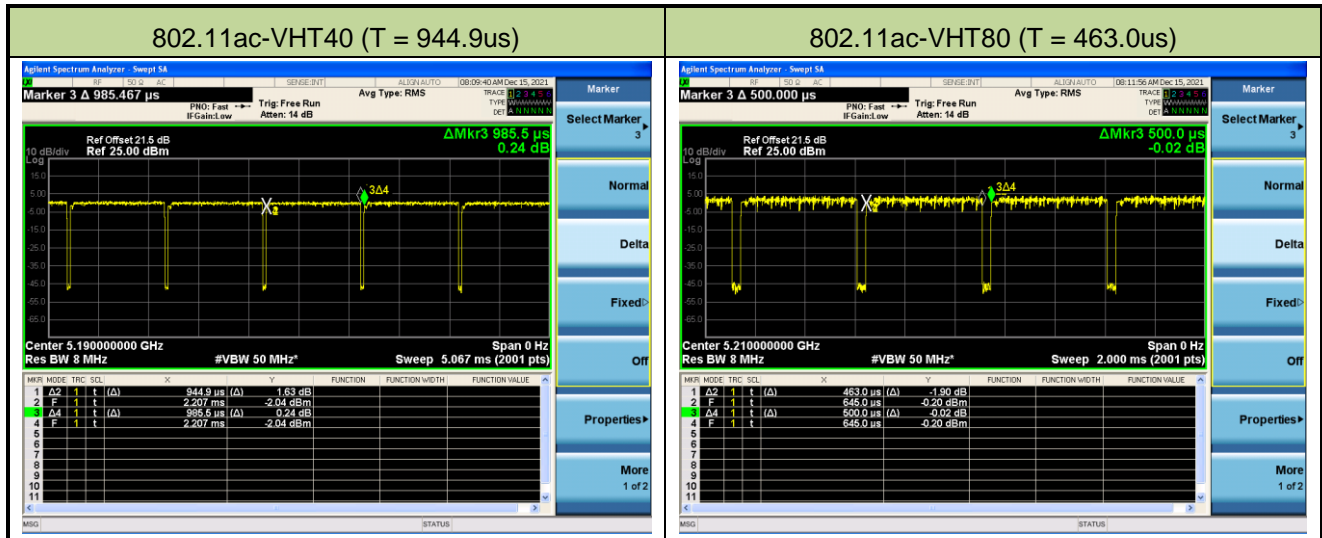



**A.2 26dB & 99% Bandwidth Test Result**

Test Site	NS-TR2	Test Engineer	Summer Tang
Test Date	2021/12/22		

Test Mode	Data Rate/ MCS	Channel No.	Frequency (MHz)	26dB Bandwidth (MHz)	99% Bandwidth (MHz)
802.11a	24Mbps	36	5180	20.82	16.51
802.11a	24Mbps	44	5220	21.01	16.52
802.11a	24Mbps	48	5240	21.03	16.49
802.11a	24Mbps	52	5260	20.90	16.53
802.11a	24Mbps	60	5300	20.80	16.51
802.11a	24Mbps	64	5320	21.09	16.52
802.11a	24Mbps	100	5500	21.03	16.52
802.11a	24Mbps	116	5580	20.99	16.51
802.11a	24Mbps	120	5600	21.23	16.49
802.11a	24Mbps	140	5700	21.12	16.52
802.11a	24Mbps	144	5720	20.92	16.51
802.11a	24Mbps	149	5745	20.84	16.51
802.11a	24Mbps	157	5785	21.22	16.50
802.11a	24Mbps	165	5825	21.05	16.51
802.11n-HT20	MCS7	36	5180	21.79	17.81
802.11n-HT20	MCS7	44	5220	22.28	17.82
802.11n-HT20	MCS7	48	5240	21.55	17.85
802.11n-HT20	MCS7	52	5260	22.40	17.81
802.11n-HT20	MCS7	60	5300	21.75	17.77
802.11n-HT20	MCS7	64	5320	22.19	17.78
802.11n-HT20	MCS7	100	5500	21.57	17.81
802.11n-HT20	MCS7	116	5580	21.56	17.82
802.11n-HT20	MCS7	120	5600	21.76	17.77
802.11n-HT20	MCS7	140	5700	21.71	17.76
802.11n-HT20	MCS7	144	5720	21.31	17.79
802.11n-HT20	MCS7	149	5745	21.91	17.82
802.11n-HT20	MCS7	157	5785	21.33	17.77
802.11n-HT20	MCS7	165	5825	22.50	17.79

Test Mode	Data Rate/ MCS	Channel No.	Frequency (MHz)	26dB Bandwidth (MHz)	99% Bandwidth (MHz)
802.11n-HT40	MCS0	38	5190	41.06	36.19
802.11n-HT40	MCS0	46	5230	41.26	36.20
802.11n-HT40	MCS0	54	5270	41.06	36.19
802.11n-HT40	MCS0	62	5310	40.58	36.17
802.11n-HT40	MCS0	102	5510	41.22	36.20
802.11n-HT40	MCS0	110	5550	40.87	36.21
802.11n-HT40	MCS0	118	5590	41.25	36.22
802.11n-HT40	MCS0	134	5670	41.12	36.18
802.11n-HT40	MCS0	142	5710	41.20	36.20
802.11n-HT40	MCS0	151	5755	41.19	36.19
802.11n-HT40	MCS0	159	5795	41.23	36.19
802.11ac-VHT20	MCS7	36	5180	21.87	17.84
802.11ac-VHT20	MCS7	44	5220	21.87	17.79
802.11ac-VHT20	MCS7	48	5240	22.04	17.83
802.11ac-VHT20	MCS7	52	5260	21.84	17.83
802.11ac-VHT20	MCS7	60	5300	21.98	17.82
802.11ac-VHT20	MCS7	64	5320	21.77	17.80
802.11ac-VHT20	MCS7	100	5500	21.78	17.79
802.11ac-VHT20	MCS7	116	5580	21.92	17.82
802.11ac-VHT20	MCS7	120	5600	22.10	17.82
802.11ac-VHT20	MCS7	140	5700	22.04	17.81
802.11ac-VHT20	MCS7	144	5720	21.88	17.82
802.11ac-VHT20	MCS7	149	5745	22.09	17.82
802.11ac-VHT20	MCS7	157	5785	22.33	17.80
802.11ac-VHT20	MCS7	165	5825	21.97	17.83

Test Mode	Data Rate/ MCS	Channel No.	Frequency (MHz)	26dB Bandwidth (MHz)	99% Bandwidth (MHz)
802.11ac-VHT40	MCS0	38	5190	41.11	36.19
802.11ac-VHT40	MCS0	46	5230	40.89	36.16
802.11ac-VHT40	MCS0	54	5270	40.92	36.16
802.11ac-VHT40	MCS0	62	5310	40.87	36.18
802.11ac-VHT40	MCS0	102	5510	41.38	36.22
802.11ac-VHT40	MCS0	110	5550	41.23	36.21
802.11ac-VHT40	MCS0	118	5590	40.56	36.19
802.11ac-VHT40	MCS0	134	5670	41.05	36.18
802.11ac-VHT40	MCS0	142	5710	41.13	36.18
802.11ac-VHT40	MCS0	151	5755	40.93	36.19
802.11ac-VHT40	MCS0	159	5795	40.70	36.19
802.11ac-VHT80	MCS0	42	5210	82.94	75.59
802.11ac-VHT80	MCS0	58	5290	82.82	75.57
802.11ac-VHT80	MCS0	106	5530	83.17	75.53
802.11ac-VHT80	MCS0	122	5610	83.55	75.59
802.11ac-VHT80	MCS0	138	5690	83.33	75.52
802.11ac-VHT80	MCS0	155	5775	82.76	75.54

## 802.11a 26dB &amp; 99% Bandwidth

## Channel 36 (5180MHz)

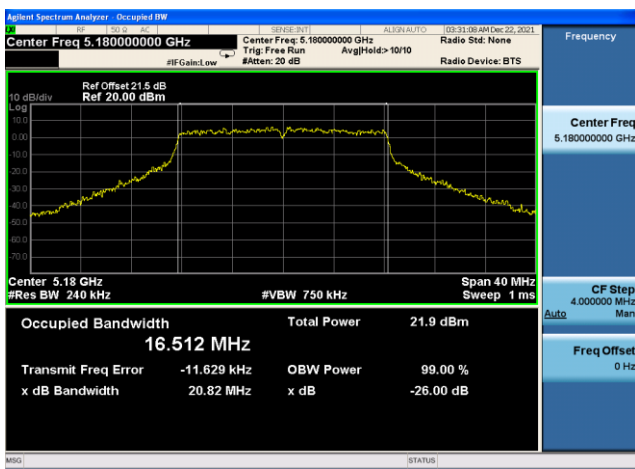

## Channel 44 (5220MHz)

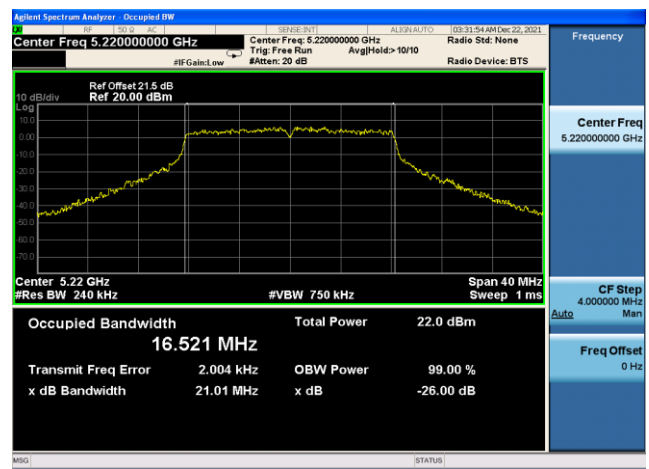

## Channel 48 (5240MHz)

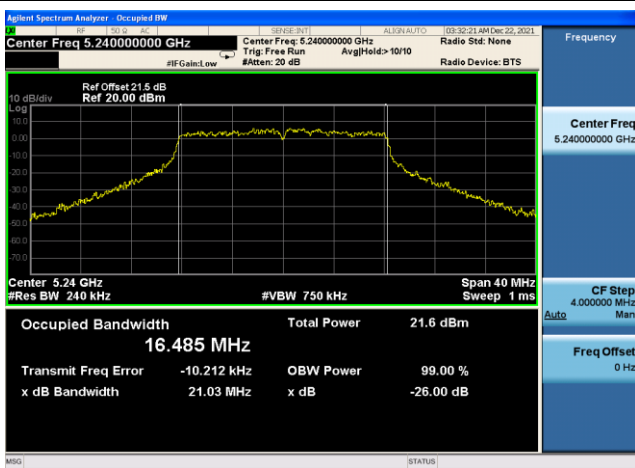

## Channel 52 (5260MHz)

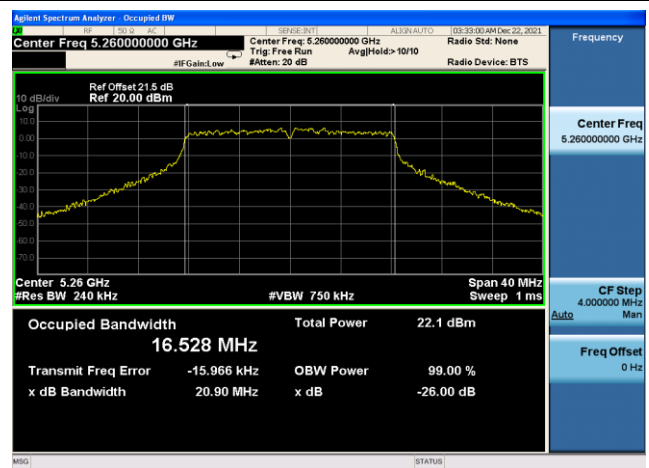

## Channel 60 (5300MHz)

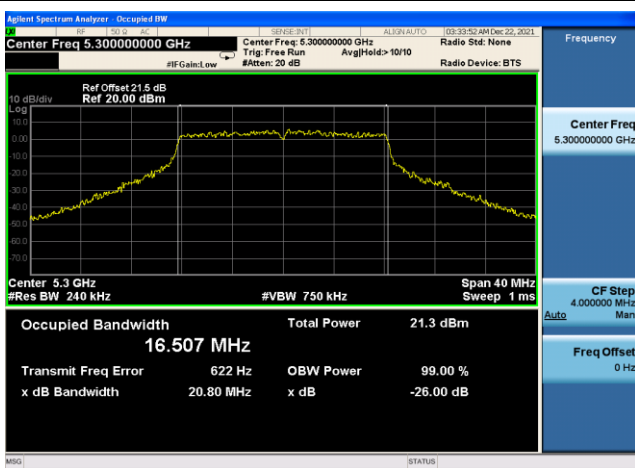

## Channel 64 (5320MHz)

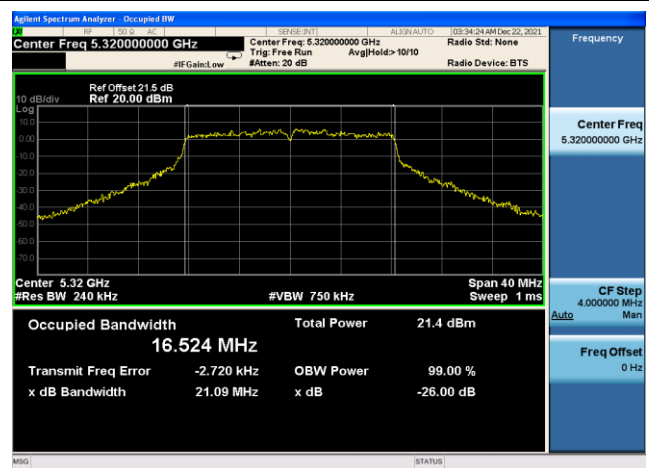



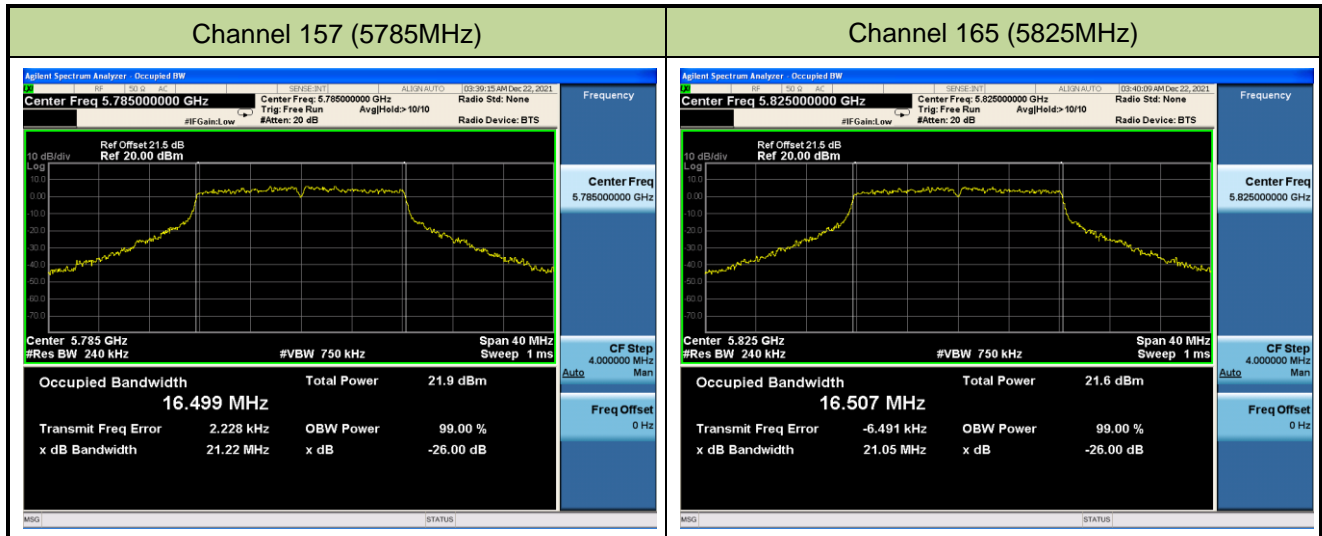

802.11n-HT20 26dB & 99% Bandwidth

Channel 36 (5180MHz)

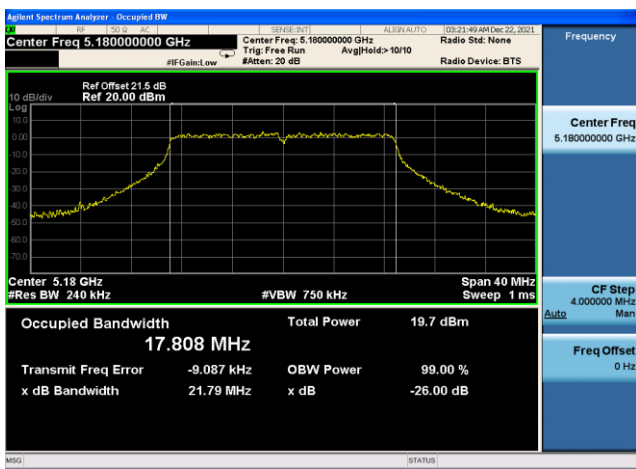

Channel 44 (5220MHz)

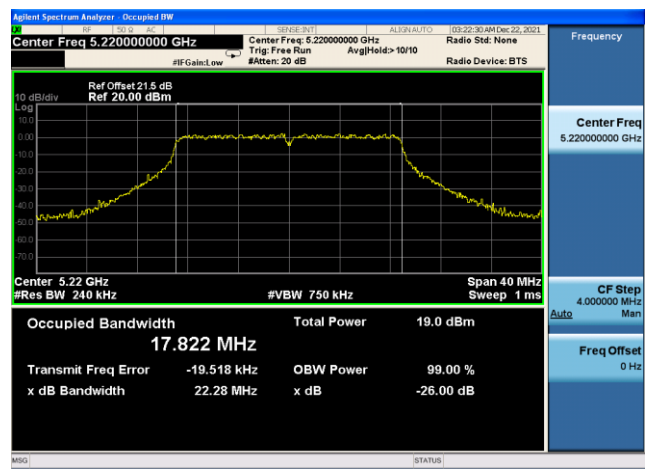

Channel 48 (5240MHz)

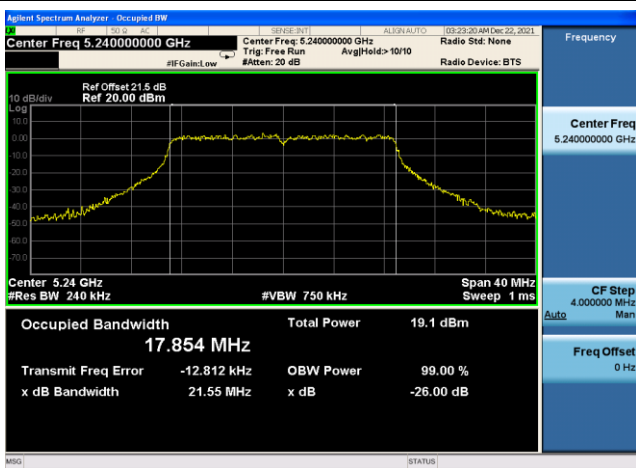

Channel 52 (5260MHz)

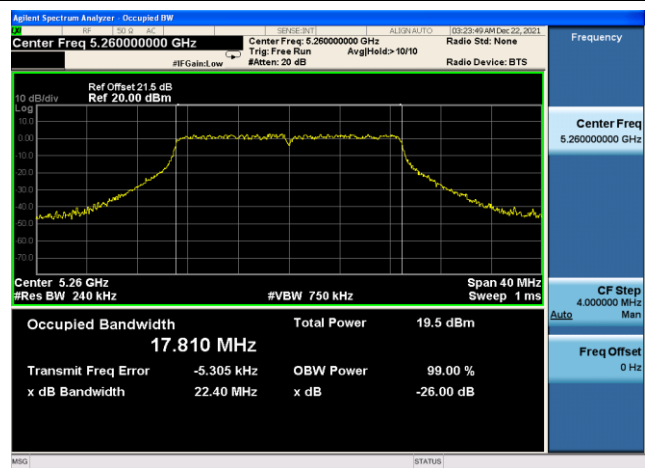

Channel 60 (5300MHz)

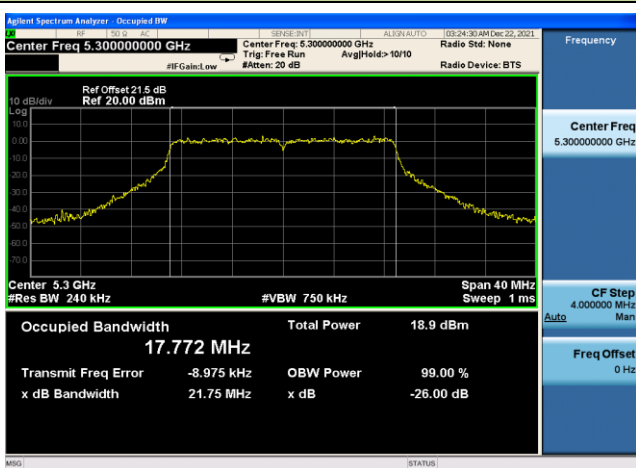

Channel 64 (5320MHz)

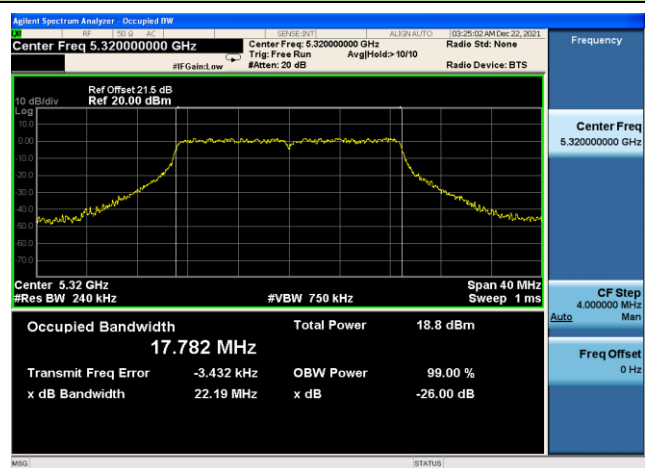

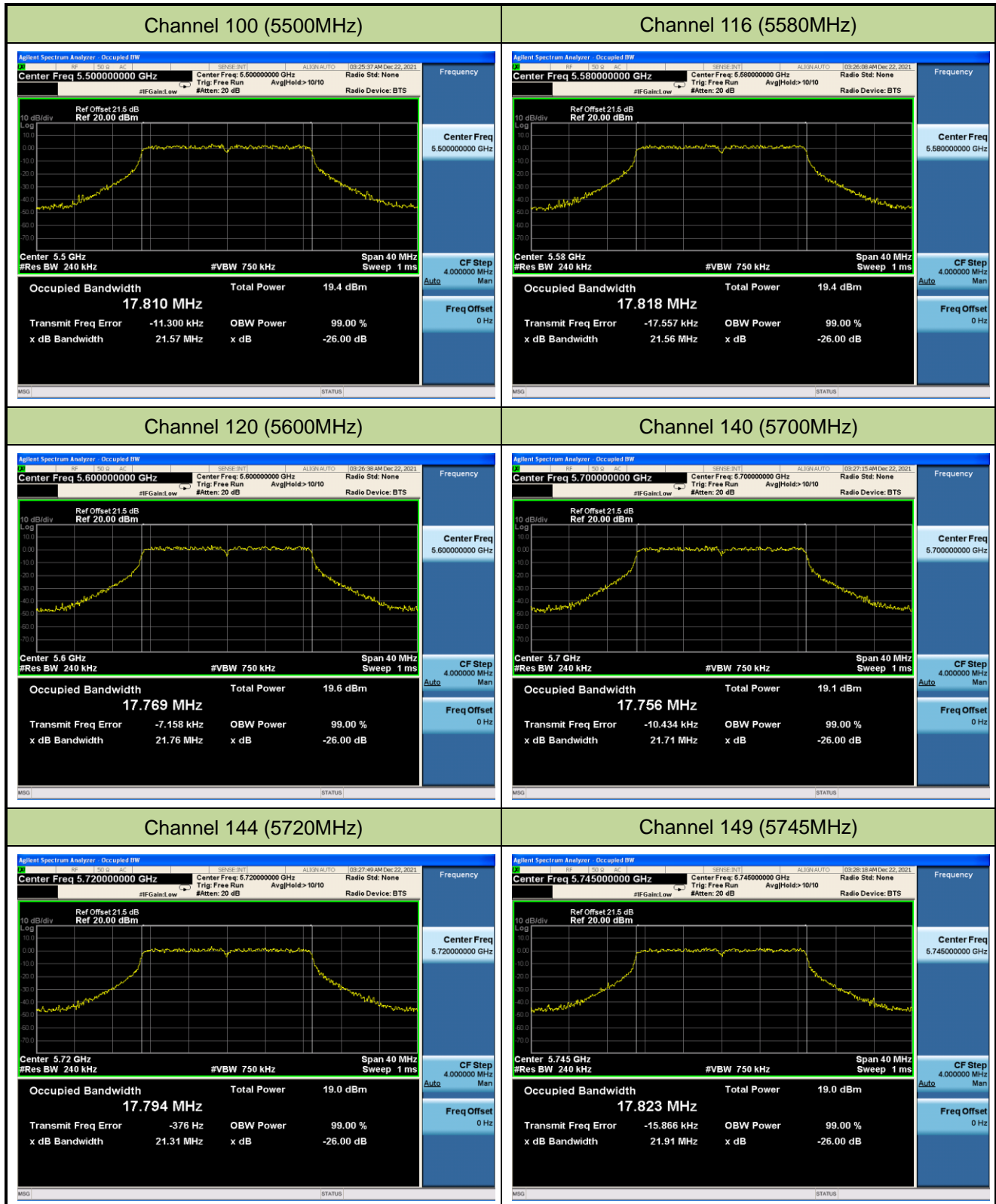



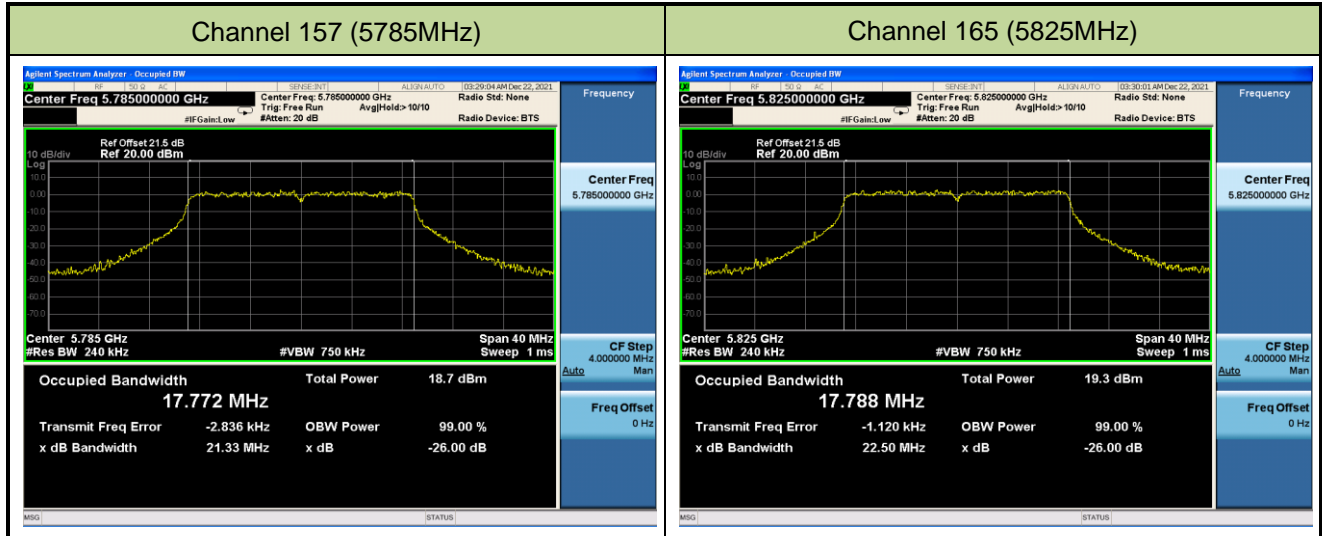

## 802.11n-HT40 26dB &amp; 99% Bandwidth

## Channel 38 (5190MHz)

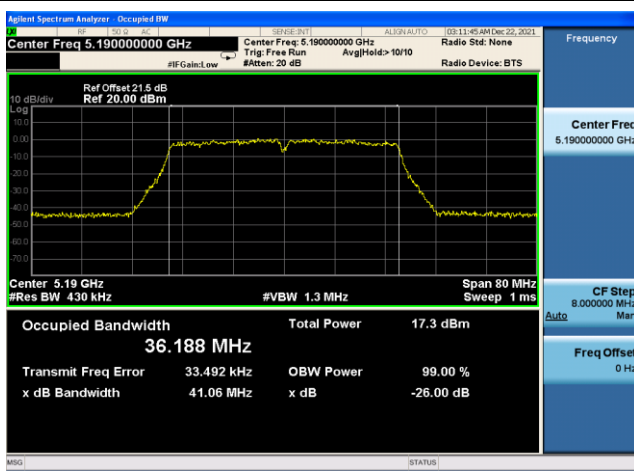

## Channel 46 (5230MHz)

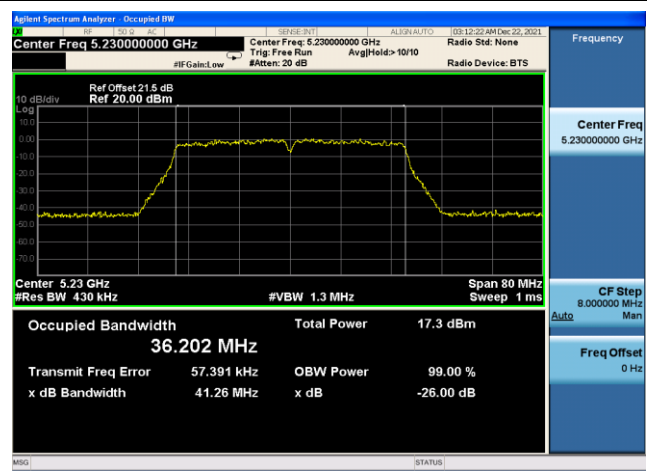

## Channel 54 (5270MHz)

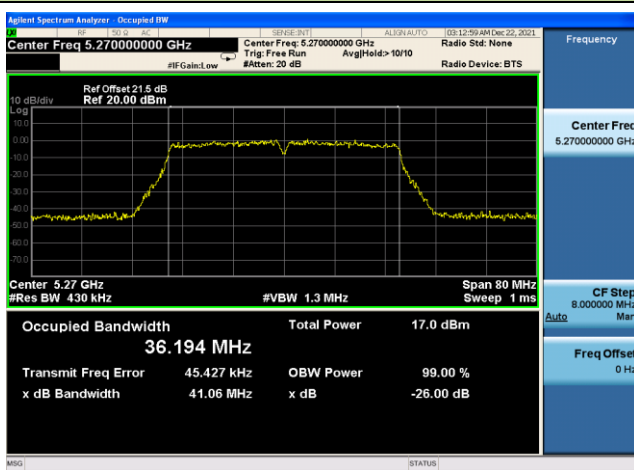

## Channel 62 (5310MHz)

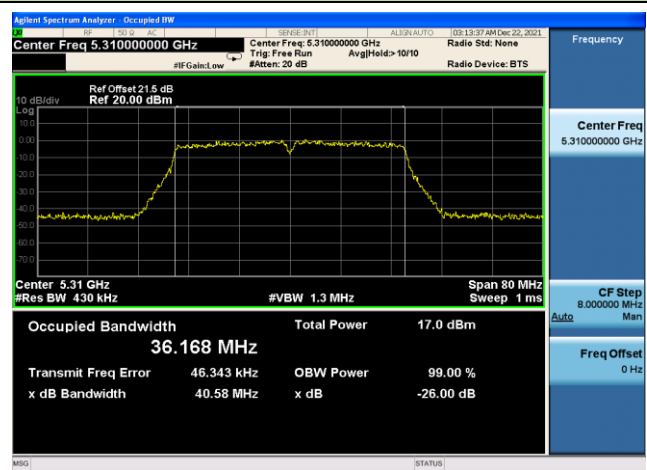

## Channel 102 (5510MHz)

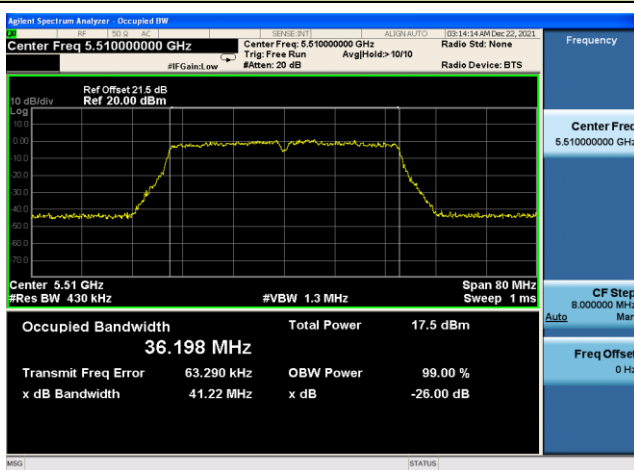

## Channel 110 (5550MHz)

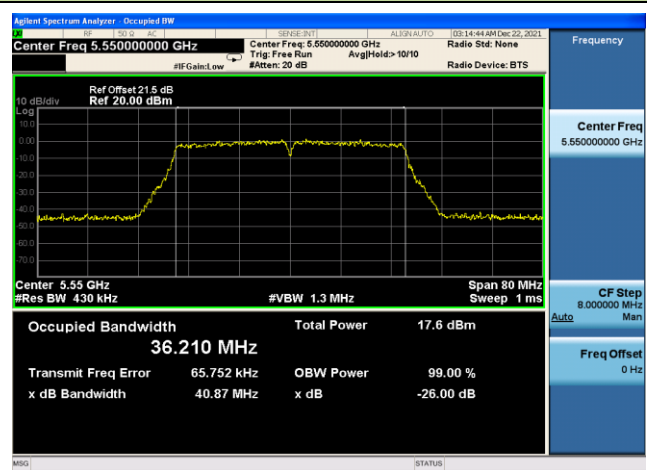

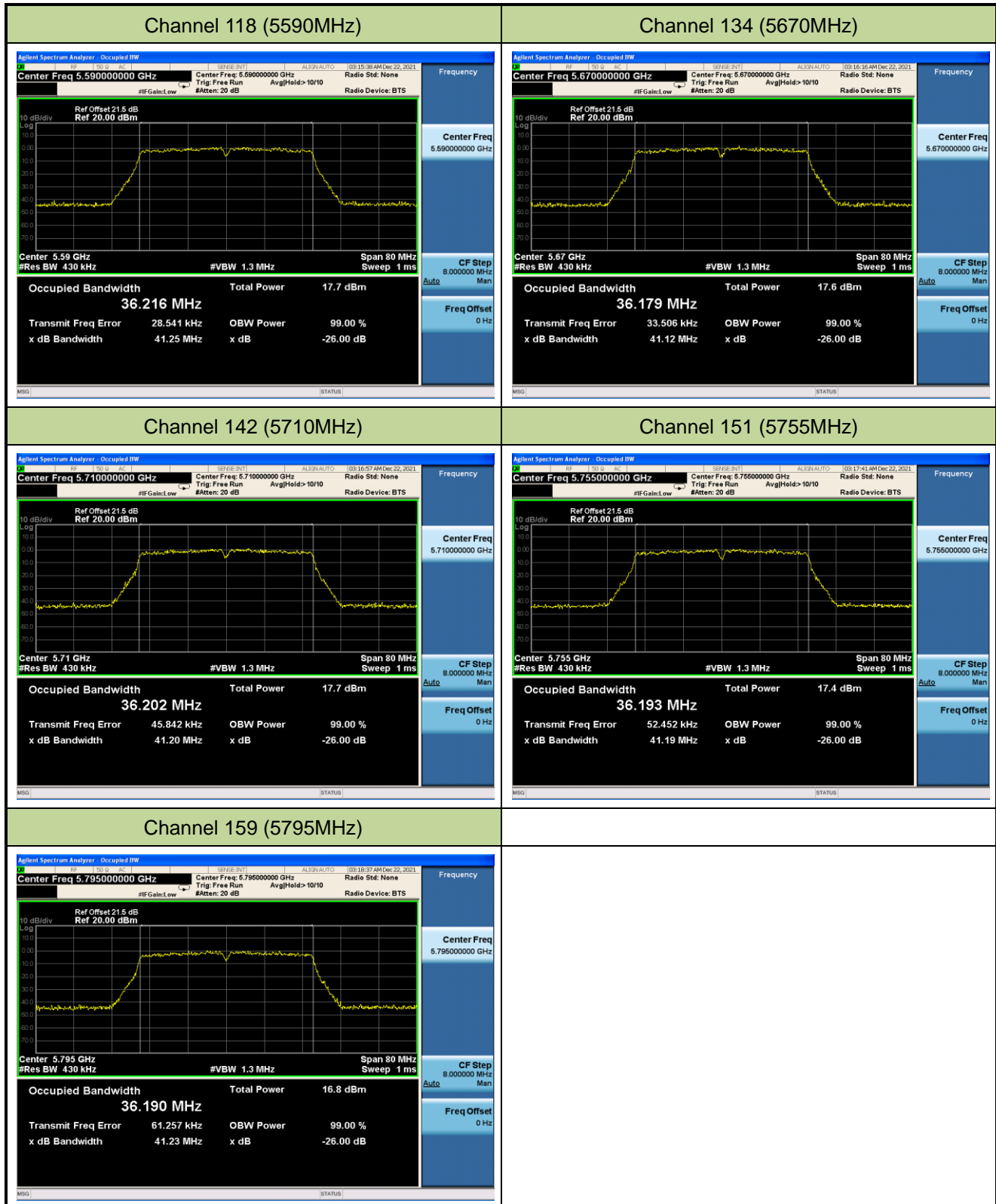

## 802.11ac-VHT20 26dB &amp; 99% Bandwidth

Channel 36 (5180MHz)

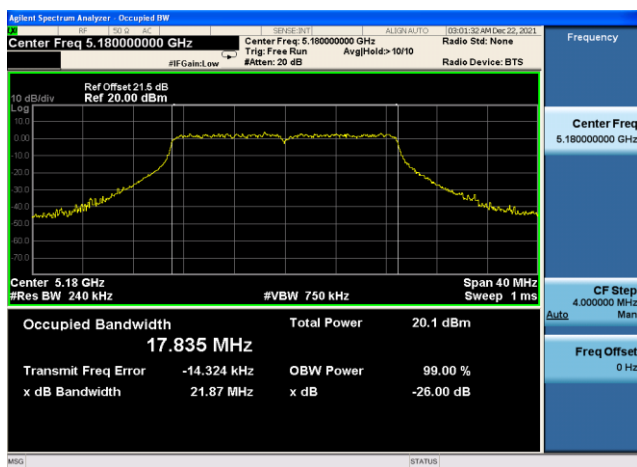

Channel 44 (5220MHz)

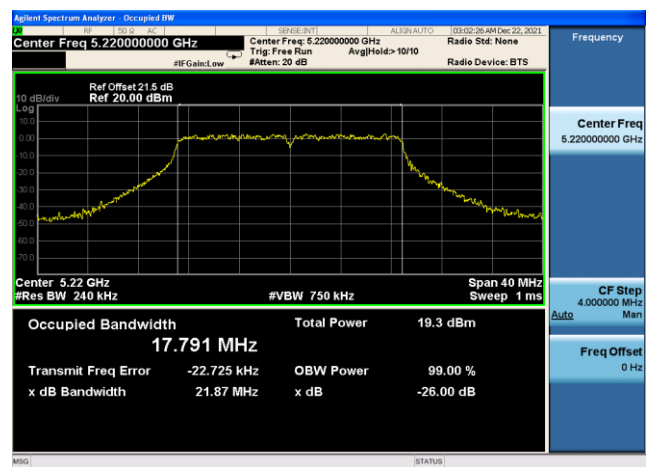

Channel 48 (5240MHz)

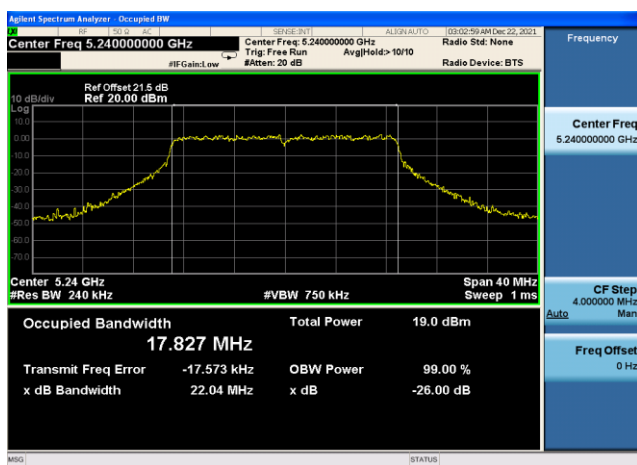

Channel 52 (5260MHz)

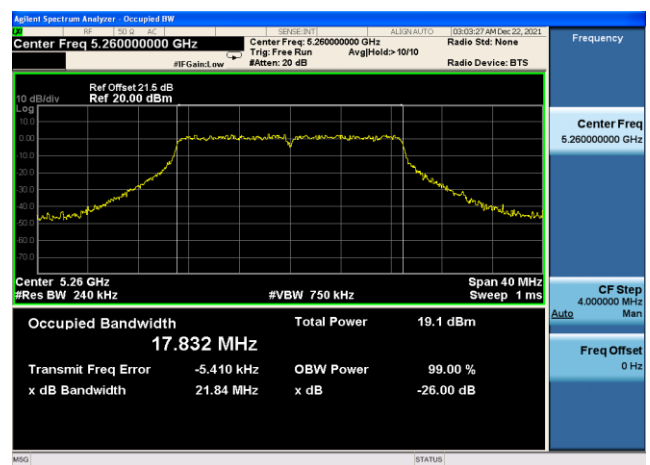

Channel 60 (5300MHz)

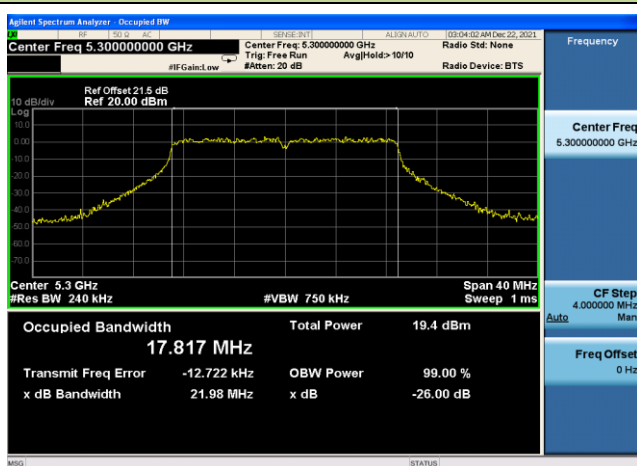

Channel 64 (5320MHz)

