

FCC HAC (RF Emission) Test Report

Report No. : HCA211129W001SA01
Applicant : Honeywell International Inc
Honeywell Safety and Productivity Solutions
Address : 9680 Old Bailes Road, Fort Mill, SC 29707 United States
Product : Mobile Computer
FCC ID : HD5-CT45PL1NE
Brand : Honeywell
Model No. : CT45P-L1N-E
Standards : FCC 47 CFR Part 20.19, ANSI C63.19-2011
KDB 285076 D01 v05, KDB 285076 D02 v03
Sample Received Date : Aug.10,2021
Date of Testing : Aug.15,2021~ Aug.16,2021
Summary M-Rating : M4

CERTIFICATION: The above equipment have been tested by **BV 7LAYERS COMMUNICATIONS TECHNOLOGY (SHENZHEN) CO. LTD.**, and found compliance with the requirement of the above standards. The test record, data evaluation & Equipment Under Test (EUT) configurations represented herein are true and accurate accounts of the measurements of the sample's HAC characteristics under the conditions specified in this report. It should not be reproduced except in full, without the written approval of our laboratory. The client should not use it to claim product certification, approval, or endorsement by A2LA or any government agencies.

Prepared By : Jerry Chen
Jerry Chen / Engineer
Approved By : Luke Lu
Luke Lu / Manager



This report is for your exclusive use. Any copying or replication of this report to or for any other person or entity, or use of our name or trademark, is permitted only with our prior written permission. This report sets forth our findings solely with respect to the test samples identified herein. The results set forth in this report are not indicative or representative of the quality or characteristics of the lot from which a test sample was taken or any similar or identical product unless specifically and expressly noted. Our report includes all of the tests requested by you and the results thereof based upon the information that you provided to us. You have 60 days from date of issuance of this report to notify us of any material error or omission caused by our negligence, provided, however, that such notice shall be in writing and shall specifically address the issue you wish to raise. A failure to raise such issue within the prescribed time shall constitute your unqualified acceptance of the completeness of this report, the tests conducted and the correctness of the report contents. Unless specific mention, the uncertainty of measurement has been explicitly taken into account to declare the compliance or non-compliance to the specification.

Table of Contents

Release Control Record	3
1. Summary of Maximum M-Rating	4
2. Description of Equipment Under Test.....	5
3. HAC RF Emission Measurement System.....	7
3.1 SPEAG DASYS System	7
3.1.1 Robot.....	8
3.1.2 Probes.....	8
3.1.3 Data Acquisition Electronics (DAE)	9
3.1.4 Phantoms	9
3.1.5 Device Holder.....	9
3.1.6 RF Emission Calibration Dipoles.....	9
3.2 DASYS System Verification.....	10
3.3 EUT Measurements Reference and Plane.....	11
3.4 HAC RF Emission Measurement Procedure.....	12
3.5 Modulation Interference Factor	14
4. HAC Measurement Evaluation.....	16
4.1 M-Rating Category	16
4.2 EUT Configuration and Setting.....	16
4.3 System Verification	16
4.4 Maximum Target Conducted Power	17
4.5 Low Power Exemption Evaluation.....	19
4.6 Measured Conducted Power Results.....	20
4.7 HAC RF Emission Testing Results	21
5. Calibration of Test Equipment.....	22
6. Measurement Uncertainty.....	23
7. Information of the Testing Laboratories.....	24
Appendix A. Plots of System Verification	
Appendix B. Plots of HAC RF Emission Measurement	
Appendix C. Calibration Certificate for Probe and Dipole	
Appendix D. Photographs of EUT and Setup	

1. Summary of Maximum M-Rating

Mode	Band	Maximum Audio Interference Level (dBV/m)	M-Rating
GSM	GSM850	32.3	M4
	GSM1900	23.11	M4
WCDMA	Band II	N/A	M4
	Band IV	N/A	M4
	Band V	N/A	M4
FDD-LTE	Band 2	N/A	M4
	Band 4	N/A	M4
	Band 5	N/A	M4
	Band 7	N/A	M4
	Band 12	N/A	M4
	Band 13	N/A	M4
	Band 14	N/A	M4
	Band 17	N/A	M4
	Band 25	N/A	M4
	Band 26	N/A	M4
	Band 30	N/A	M4
	Band 66	N/A	M4
	Band 71	N/A	M4
TDD-LTE	Band 38	N/A	M4
	Band 41	24.81	M4
WLAN	WLAN2.4G	N/A	M4
	WLAN5.2G	N/A	M4
	WLAN5.3G	N/A	M4
	WLAN5.6G	N/A	M4
	WLAN5.8G	N/A	M4
Summary		M4	

Note:

1. The HAC RF emission limit (**M-rating Category M3**) is specified in FCC 47 CFR part 20.19 and ANSI C63.19.
2. The device RF emission rating is determined by the minimum rating.



FCC HAC (RF Emission) Test Report

2. Description of Equipment Under Test

EUT Type	Mobile Compute
FCC ID	HD5-CT45PL1NE
Brand Name	Honeywell
Model Name	CT45P-L1N-E
HW Version	1.0
SW Version	OS.11.002-HON.11.002
Tx Frequency Bands (Unit: MHz)	GSM GSM850 : 824.2 ~ 848.8 GSM1900 : 1850.2 ~ 1909.8 WCDMA Band II : 1852.4 ~ 1907.6 Band IV : 1712.4 ~ 1752.6 Band V : 826.4 ~ 846.6 FDD-LTE Band 2 : 1850.7 ~ 1909.3 (BW: 1.4M, 3M, 5M, 10M, 15M, 20M) Band 4 : 1710.7 ~ 1754.3 (BW: 1.4M, 3M, 5M, 10M, 15M, 20M) Band 5 : 824.7 ~ 848.3 (BW: 1.4M, 3M, 5M, 10M) Band 7 : 2502.5 ~ 2567.5 (BW: 5M, 10M, 15M, 20M) Band 12 : 699.7 ~ 715.3 (BW: 1.4M, 3M, 5M, 10M) Band 13 : 779.5 ~ 784.5 (BW: 5M, 10M) Band 14 : 790.5 ~ 795.5 (BW: 5M, 10M) Band 17 : 706.5 ~ 713.5 (BW: 5M, 10M) Band 25 : 1850.7 ~ 1914.3 (BW: 1.4M, 3M, 5M, 10M, 15M, 20M) Band 26 : 814.7 ~ 848.3 (BW: 5M, 10M) Band 30 : 2307.5 ~ 2312.5 (BW: 1.4M, 3M, 5M, 10M, 15M) Band 66 : 1710.7 ~ 1779.3 (BW: 1.4M, 3M, 5M, 10M, 15M, 20M) Band 71 : 665.5 ~ 695.5 (BW: 5M, 10M, 15M, 20M) TDD-LTE LTE Band 38 : 2572.5 ~ 2617.5 (BW: 5M, 10M, 15M, 20M) LTE Band 41 : 2498.5 ~ 2687.5 (BW: 5M, 10M, 15M, 20M) WLAN 2412 ~ 2462, 5180 ~ 5240, 5260 ~ 5320, 5500 ~ 5700, 5745 ~ 5825 Bluetooth 2402 ~ 2480
Modulations Supported in Uplink	GSM & GPRS : GMSK WCDMA : QPSK LTE : QPSK, 16QAM, 64QAM 802.11b : DSSS 802.11a/g/n : OFDM Bluetooth : GFSK, $\pi/4$ -DQPSK, 8-DPSK
Antenna Type	WLAN: PIFA Antenna WWAN: PIFA Antenna
EUT Stage	Production Unit

Note:

- The above EUT information is declared by manufacturer and for more detailed features description please refers to the manufacturer's specifications or User's Manual.

List of Accessory:

Battery	Brand Name	Honeywell
	Model Name	CT50-BTSC
	Power Rating	3.85Vdc,4020mA
	Type	Li-ion

FCC HAC (RF Emission) Test Report

Air Interface and Operational Mode:

Air Interface	Bands	Transport Type	HAC Tested	Simultaneous But Not Tested	Name of Voice Service	Power Reduction
GSM	850	VO	YES	WLAN or BT	CMRS Voice	No
	1900					No
	EGPRS	DT	No	WLAN or BT	N/A	No
WCDMA	II	VO	No ⁽¹⁾	WLAN or BT	CMRS Voice	No
	IV					No
	V					No
	HSPA	DT	No	WLAN or BT	N/A	No
FDD-LTE	2	VD	No ⁽¹⁾	WLAN or BT	VoLTE	No
	4					No
	5					No
	7					No
	12					No
	13					No
	14					No
	17					No
	25					No
	26					No
	30					No
	66					No
TDD-LTE	38	VD	YES	WLAN or BT	VoLTE	No
	41					No
WLAN	2.4G	DT	No ⁽¹⁾	WWAN	N/A	No
	5.2G	DT	No ⁽¹⁾		N/A	No
	5.3G					No
	5.6G					No
	5.8G					No
Bluetooth	2.4G	DT	No	WWAN	N/A	No
Transport Type VO = Legacy Cellular Voice Service DT = Digital Transport Only (No Voice) VD = IP Voice Service over Digital Transport			Note 1. It applies the low power exemption per ANSI C63.19-2011. 2. The device also have similar frequencies in some bands: such as LTE B38/41, the support frequency span for the smaller band are completely covered by the larger band, therefore only larger bands are required to be tested.			

3. HAC RF Emission Measurement System

3.1 SPEAG DASY System

DASY system consists of high precision robot, probe alignment sensor, phantom, robot controller, controlled measurement server and near-field probe. The robot includes six axes that can move to the precision position of the DASY5 software defined. The DASY software can define the area that is detected by the probe. The robot is connected to controlled box. Controlled measurement server is connected to the controlled robot box. The DAE includes amplifier, signal multiplexing, AD converter, offset measurement and surface detection. It is connected to the Electro-optical coupler (ECO). The ECO performs the conversion from the optical into digital electric signal of the DAE and transfers data to the PC.

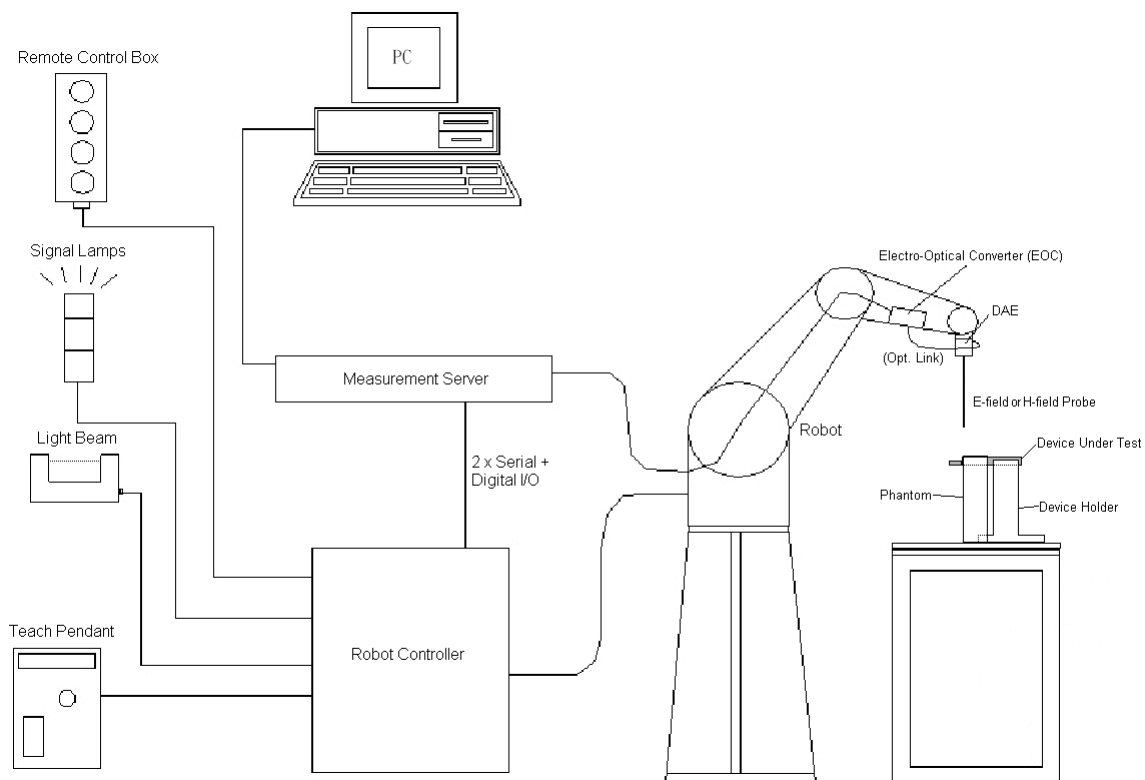

Fig-3.1 DASY System Setup

FCC HAC (RF Emission) Test Report

3.1.1 Robot

The DASY6 system uses the high precision robots from Stäubli SA (France). For the 6-axis controller system, the robot controller version (DASY6: CS8c) from Stäubli is used. The Stäubli robot series have many features that are important for our application:

- High precision (repeatability ± 0.035 mm)
- High reliability (industrial design)
- Jerk-free straight movements
- Low ELF interference (the closed metallic construction shields against motor control fields)

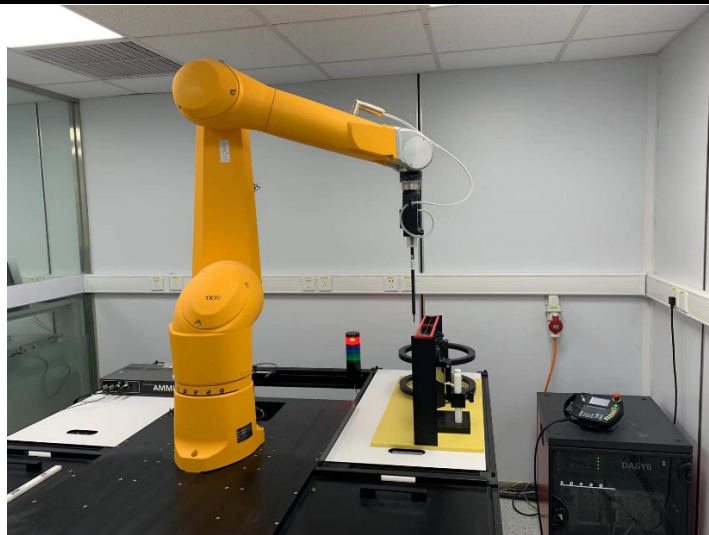



Fig-3.2 DASY6 Measurement System

3.1.2 Probes

Model	ER3DV6	
Construction	One dipole parallel, two dipoles normal to probe axis Built-in shielding against static charges	
Frequency	40 MHz to 3 GHz Linearity: ± 0.2 dB	
Directivity	± 0.2 dB in air (rotation around probe axis) ± 0.4 dB in air (rotation normal to probe axis)	
Dynamic Range	2 V/m to 1000 V/m Linearity: ± 0.2 dB	
Dimensions	Overall length: 337 mm (Tip: 16 mm) Tip diameter: 8 mm (Body: 12 mm) Distance from probe tip to dipole centers: 2.5 mm	

Model	EF3DV3	
Construction	One dipole parallel, two dipoles normal to probe axis Built-in shielding against static charges	
Frequency	40 MHz to 6 GHz Linearity: ± 0.2 dB	
Directivity	± 0.2 dB in air (rotation around probe axis) ± 0.4 dB in air (rotation normal to probe axis)	
Dynamic Range	2 V/m to 1000 V/m Linearity: ± 0.2 dB	
Dimensions	Overall length: 337 mm (Tip: 20 mm) Tip diameter: 3.9 mm (Body: 12 mm) Distance from probe tip to dipole centers: 1.5 mm	

FCC HAC (RF Emission) Test Report

3.1.3 Data Acquisition Electronics (DAE)

Model	DAE3, DAE4	
Construction	Signal amplifier, multiplexer, A/D converter and control logic. Serial optical link for communication with DASY embedded system (fully remote controlled). Two step probe touch detector for mechanical surface detection and emergency robot stop.	
Measurement Range	-100 to +300 mV (16 bit resolution and two range settings: 4mV, 400mV)	
Input Offset Voltage	< 5 μ V (with auto zero)	
Input Bias Current	< 50 fA	
Dimensions	60 x 60 x 68 mm	

3.1.4 Phantoms

Model	Test Arch	
Construction	Enables easy and well defined positioning of the phone and validation dipoles as well as simple teaching of the robot.	
Dimensions	Length : 370 mm Width : 370 mm Height : 370 mm	

3.1.5 Device Holder

Model	Mounting Device	
Construction	The Mounting Device enables the rotation of the mounted transmitter device in spherical coordinates. Rotation point is the ear opening point. Transmitter devices can be easily and accurately positioned according to ANSI C63.19.	
Material	POM	

3.1.6 RF Emission Calibration Dipoles

Model	CD-Serial	
Construction	Free space antenna Hearing Aid susceptibility measurements according to ANSI C63.19. Validation of Hearing Aid RF setup for wireless device emission measurements according to ANSI C63.19	
Frequency	CD700V3 : 698 ~ 806 MHz CD835V3 : 800 ~ 960 MHz CD1880V3 : 1710 ~ 2000 MHz CD2450V3 : 2250 ~ 2650 MHz CD2600V3 : 2450 ~ 2750 MHz CD3500V3 : 3300 ~ 3950 MHz CD5500V3 : 5000 ~ 5900 MHz	
Return Loss	CD700V3 : > 15 dB (750 MHz > 20 dB) CD835V3 : > 15 dB (835 MHz > 25 dB) CD1880V3 : > 18 dB (1880 MHz > 20 dB) CD2450V3 : > 18 dB (2450 MHz > 25 dB) CD2600V3 : > 18 dB (2600 MHz > 20 dB) CD3500V3 : > 16 dB (3500 MHz > 20 dB) CD5500V3 : > 18 dB (5500 MHz > 20 dB)	
Power Capability	> 40 W continuous	

3.2 DASY System Verification

The system check verifies that the system operates within its specifications. It is performed before every E-field measurement. The system check uses normal measurements in the center section of the arch phantom with a matched dipole at a specified distance. The system verification setup is shown as below.

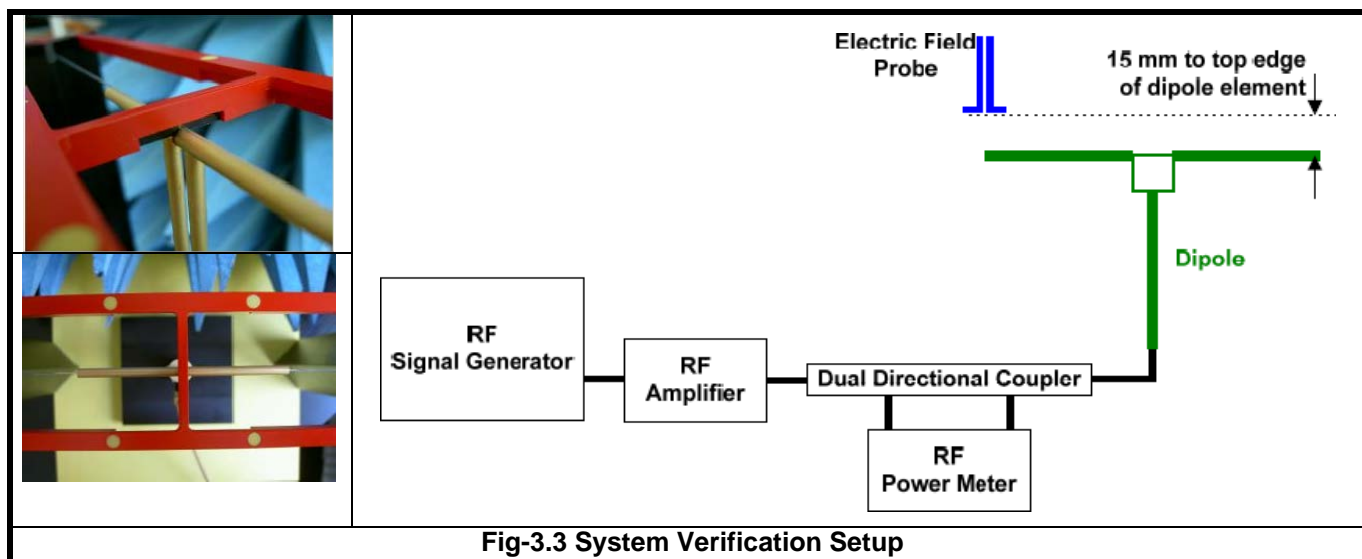

Fig-3.3 System Verification Setup

The validation dipole is placed beneath the center of arch phantom. The power meter measures the forward power at the location of the system check dipole connector. The signal generator is adjusted for the desired forward power, 100 mW (20 dBm) at the dipole connector and the RF power meter is read at that level. After connecting the cable to the dipole, the signal generator is readjusted for the same reading at RF power meter.

After system check testing, the E-field result will be compared with the reference value derived from validation dipole certificate report. The deviation of system check should be within 25 %.

The result of system verification is shown in section 4.3 of this report.

3.3 EUT Measurements Reference and Plane

The EUT is mounted in the device holder. The acoustic output of the EUT will coincide with the center point of the area formed by the dielectric wire and the middle bar of the arch's top frame. Then EUT will be moved vertically upwards until it touches the frame.

Fig-3.4 and Fig-3.5 illustrate the references and reference plane that is used in the RF emissions measurement.

- (a) The grid is 50 mm by 50 mm area that is divided into nine evenly sized blocks or sub-grids.
- (b) The grid is centered on the audio frequency output transducer of the EUT.
- (c) The grid is in a reference plane, which is defined as the planar area that contains the highest point in the area of the phone that normally rests against the user's ear. It is parallel to the centerline of the receiver area of the phone and is defined by the points of the receiver-end of the EUT handset, which in normal handset use rest against the ear.
- (d) The measurement plane is parallel to and 15 mm in front of the reference plane.



Fig-3.4 EUT Reference and Plane

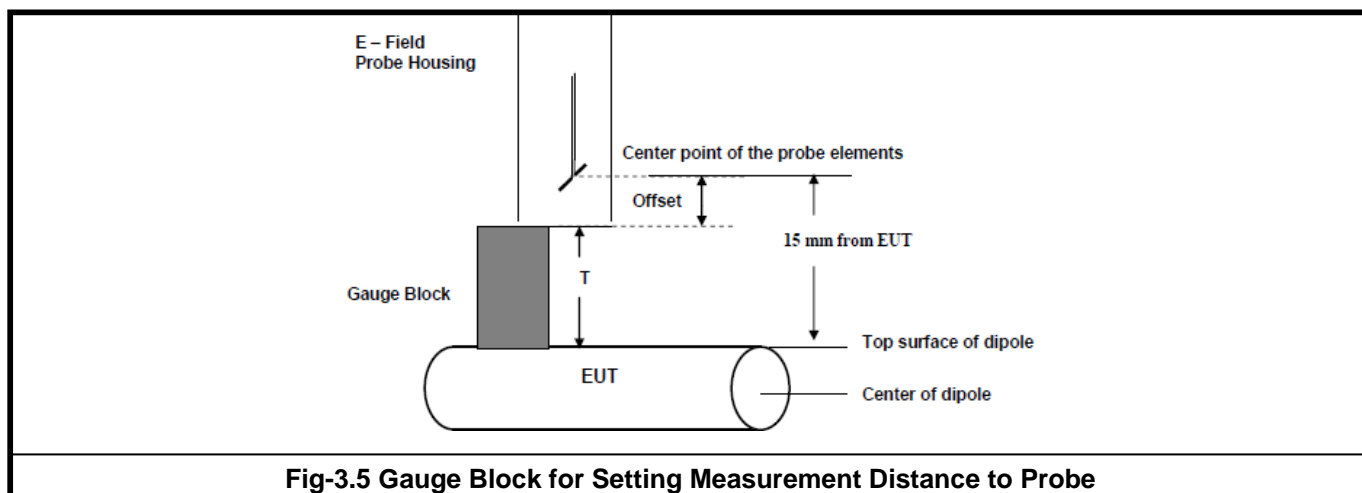

Fig-3.5 Gauge Block for Setting Measurement Distance to Probe

3.4 HAC RF Emission Measurement Procedure

The RF emissions test procedure for wireless communications device is as below.

1. Confirm the proper operation of the field probe, probe measurement system, and other instrumentation and the positioning system.
2. Position the WD in its intended test position.
3. Set the WD to transmit a fixed and repeatable combination of signal power and modulation characteristic that is representative of the worst case (highest interference potential) encountered in normal use. Transiently occurring start-up, changeover, or termination conditions, or other operations likely to occur less than 1% of the time during normal operation, may be excluded from consideration.
4. The center sub-grid shall be centered on the T-Coil mode perpendicular measurement point or the acoustic output, as appropriate. Locate the field probe at the initial test position in the 50 mm by 50 mm grid, which is contained in the measurement plane, illustrated in Fig-3.4. If the field alignment method is used, align the probe for maximum field reception.
5. Record the reading at the output of the measurement system.
6. Scan the entire 50 mm by 50 mm region in equally spaced increments and record the reading at each measurement point. The distance between measurement points shall be sufficient to assure the identification of the maximum reading.
7. Identify the five contiguous sub-grids around the center sub-grid whose maximum reading is the lowest of all available choices. This eliminates the three sub-grids with the maximum readings. Thus, the six areas to be used to determine the WD's highest emissions are identified.
8. Identify the maximum reading within the non-excluded sub-grids identified in step 7.
9. Indirect Measurement Method: The RF audio interference level in dB(V/m) is obtained by adding the MIF (in dB) to the maximum steady-state rms field-strength reading, in dB(V/m), from step 8. Use this result to determine the category rating.

- 10. Compare this RF audio interference level with the categories in section 4.1 and record the resulting WD category rating.
- 11 For the T-Coil mode M-rating assessment, determine whether the chosen perpendicular measurement point is contained in an included sub-grid of the first can. If so, then a second scan is not necessary. The first scan and resultant category rating may be used for the T-Coil mode M-rating. Otherwise, repeat step 1 through step 9, with the grid shifted so that it is centered on the perpendicular measurement point. Record the WD category rating.

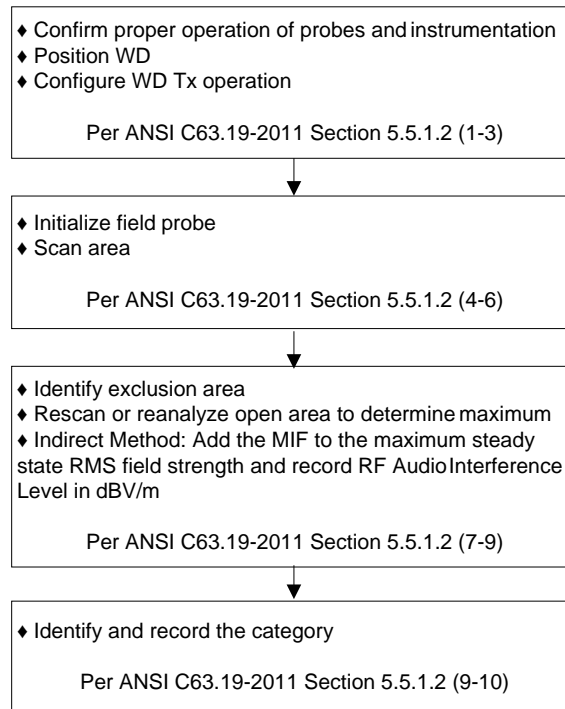

Fig-3.6 WD Near-Field Emission Test Flowchart

3.5 Modulation Interference Factor

The HAC Standard ANSI C63.19-2011 defines a new scaling using the Modulation Interference Factor (MIF) which replaces the need for the Articulation Weighting Factor (AWF) during the evaluation and is applicable to any modulation scheme.

The Modulation Interference Factor (MIF, in dB) is added to the measured average E-field (in dBV/m) and converts it to the RF audio interference potential (in dBV/m). This level considers the audible amplitude modulation components in the RF E-field. CW fields without amplitude modulation are assumed to not interfere with the hearing aid electronics. Modulations without time slots and low fluctuations at low frequencies have low MIF values, TDMA modulations with narrow transmission slots and repetition rates of few 100 Hz have high MIF values and give similar classification as ANSI C63.19-2007.

ER3D E-field probe have a bandwidth <10 kHz and can therefore not evaluate the RF envelope in the full audio band. DASY52 is therefore using the "indirect" measurement method according to ANSI C63.19-2011 which is the primary method. This near field probe read the averaged E-field. Especially for the new high peak-to-average (PAR) signal types, the probes shall be linearized by PMR calibration in order to not overestimate the field reading.

The evaluation method for the MIF is defined in ANSI C63.19-2011 section D.7. An RMS demodulated RF signal is fed to a spectral filter (similar to an A weighting filter) and forwarded to a temporal filter acting as a quasi-peak detector. The averaged output of these filtering is scaled to a 1 kHz 80% AM signal as reference. It may alternatively be determined through analysis and simulation, because it is constant and characteristic for a communication signal. DASY52 uses well-defined signals for PMR calibration. The MIF of these signals has been determined numerically. It allows a precise scaling and is therefore automatically applied.

The following table lists the MIF values evaluated by DASY manufacturer (SPEAG), and the test result will be calculated with the MIF parameter automatically. The detailed parameters for E-field probe can be found in the probe calibration report in appendix C.

UID	Reversion	Communication System Name	MIF (dB)
10021	DAC	GSM-FDD (TDMA, GMSK)	3.63
10025	DAC	EDGE-FDD (TDMA, 8PSK, TN 0)	3.75
10460	AAA	UMTS-FDD (WCDMA, AMR)	-25.43
10225	CAB	UMTS-FDD (HSPA+)	-20.39
10081	CAB	CDMA2000 (1xRTT, RC3)	-19.71
10295	AAB	CDMA2000, RC1, SO3, 1/8th Rate 25 fr.	3.26
10403	AAB	CDMA2000 (1xEV-DO, Rev. 0)	-17.67
10170	CAE	LTE-FDD (SC-FDMA, 1 RB, 20 MHz, 16-QAM)	-9.76
10172	CAG	LTE-TDD (SC-FDMA, 1 RB, 20 MHz, QPSK)	-1.62
10173	CAG	LTE-TDD (SC-FDMA, 1 RB, 20 MHz, 16-QAM)	-1.44
10174	CAG	LTE-TDD (SC-FDMA, 1 RB, 20 MHz, 64-QAM)	-1.54
10061	CAB	IEEE 802.11b WiFi 2.4 GHz (DSSS, 11 Mbps)	-2.02
10077	CAB	IEEE 802.11g WiFi 2.4 GHz (DSSS/OFDM, 54 Mbps)	0.12
10427	AAB	IEEE 802.11n (HT Greenfield, 150 Mbps, 64-QAM)	-13.44
10069	CAC	IEEE 802.11a/h WiFi 5 GHz (OFDM, 54 Mbps)	-3.15
10616	AAB	IEEE 802.11ac WiFi (40MHz, MCS0, 90pc duty cycle)	-5.57



FCC HAC (RF Emission) Test Report

The MIF measurement uncertainty listed in following table is estimated by SPEAG.

MIF (dB)	MIF Measurement Uncertainty (dB)
-7 to +5	0.2
-13 to +11	0.5
> -20	1.0

4. HAC Measurement Evaluation

4.1 M-Rating Category

The HAC Standard ANSI C63.19-2011 represents performance requirements for acceptable interoperability of hearing aids with wireless communications devices. When these parameters are met, a hearing aid operates acceptably in close proximity to a wireless communications device.

Emission Categories	E-Field Emissions < 960 MHz (dB V/m)	E-Field Emissions > 960 MHz (dB V/m)
Category M1	50 - 55	40 - 45
Category M2	45 - 50	35 - 40
Category M3	40 - 45	30 - 35
Category M4	< 40	< 30

4.2 EUT Configuration and Setting

For HAC RF emission testing, the EUT was linked and controlled by base station emulator. Communication between the EUT and the emulator was established by air link. The distance between the EUT and the communicating antenna of the emulator is larger than 50 cm and the output power radiated from the emulator antenna is at least 30 dB smaller than the output power of EUT. The EUT was set from the emulator to radiate maximum output power during HAC testing.

4.3 System Verification

The measuring results for system check are shown as below.

Frequency (MHz)	Input Power (dBm)	Target Value (V/m)	E-Field 1 (V/m)	E-Field 2 (V/m)	Average E-Field (V/m)	Deviation (%)	Test Date
835	20.0	105	104	122.9	113.45	8.05	Aug.15,2021
1880	20.0	86.3	92.02	89.53	90.78	5.19	Aug.15,2021
2600	20.0	83.8	84.93	86.61	85.77	2.35	Aug.15,2021

Note:

1. Comparing to the reference target value provided by SPEAG, the validation data should be within its specification of 25 %. The result indicates the system check can meet the variation criterion and the plots can be referred to Appendix A of this report.
2. For E-Field, the deviation is $[(E\text{-Field } 1 + E\text{-Field } 2) / 2 - \text{Target Value}] / \text{Target Value} \times 100\%$

4.4 Maximum Target Conducted Power

The maximum conducted average power (Unit: dBm) including tune-up tolerance is shown as below.

Air Interface		Max. Tune-up Power	
GSM	GSM850	32.0	
	EDGE850	26.5	
	GSM1900	29.5	
	EDGE1900	26.0	
WCDMA	Band II	22.0	
	Band IV	21.5	
	Band V	24.0	
FDD-LTE	Band 2	21.5	
	Band 4	21.0	
	Band 5	24.5	
	Band 7	22.0	
	Band 12	23.5	
	Band 13	24.0	
	Band 14	24.0	
	Band 25	21.5	
	Band 26	24.5	
	Band 30	24.0	
	Band 66	21.0	
	Band 71	23.0	
TDD-LTE	Band 38	QPSK	23.0
		16QAM	22.0
		64QAM	21.0
	Band 41	QPSK	23.0
		16QAM	22.0
		64QAM	21.0

FCC HAC (RF Emission) Test Report

	Air Interface	Max. Tune-up Power
WLAN 2.4G	802.11b	15.5
	802.11g	15.5
	802.11n HT20	15.0
	802.11n HT40	16.5
WLAN 5.2G	802.11a	16.0
	802.11n HT20	16.0
	802.11n HT40	15.5
WLAN 5.3G	802.11a	16.0
	802.11n HT20	16.0
	802.11n HT40	15.5
WLAN 5.6G	802.11a	17.0
	802.11n HT20	16.0
	802.11n HT40	16.5
WLAN 5.8G	802.11a	18.0
	802.11n HT20	17.0
	802.11n HT40	17.0

4.5 Low Power Exemption Evaluation

According to ANSI C63.19-2011 section 4, RF air interface technologies that have low power have been found to produce sufficiently low RF interference potential, so it is possible to exempt them from the product testing. An RF air interface technology of a device is exempt from testing when its average antenna input power plus its worst-case MIF is ≤ 17 dBm for any of its operating modes. If a device supports multiple RF air interfaces, each RF air interface shall be evaluated individually. An RF air interface technology that is exempted from testing by above method could be rated as M4.

The low power exemption for this device is analyzed in below.

Air Interface		Max. Tune-up Power (dBm)	Worst Case MIF (dB)	Power + MIF (dB)	C63.19 Testing Required
GSM	GSM850	32.0	3.63	35.63	YES
	EDGE850	26.5	3.75	30.25	No
	GSM1900	29.5	3.63	33.13	YES
	EDGE1900	26.0	3.75	29.75	No
WCDMA	AMR	24.0	-25.43	-1.43	No
	HSPA	23.0	-20.39	2.61	No
FDD-LTE		24.5	-9.76	14.74	No
TDD-LTE	QPSK	23.0	-1.44	21.56	YES
	16QAM	22.0	-1.44	20.56	YES
	64QAM	21.0	-1.44	19.56	YES
WLAN 2.4G	802.11b	15.5	-2.02	13.48	No
	802.11g	15.5	0.12	15.62	No
	802.11n HT20	15.0	-13.44	1.56	No
	802.11n HT40	16.5	-13.44	3.06	No
WLAN 5.2G	802.11a	16.0	-3.15	12.85	No
	802.11n HT20	16.0	-13.44	2.56	No
	802.11n HT40	15.5	-13.44	2.06	No
WLAN 5.3G	802.11a	16.0	-3.15	12.85	No
	802.11n HT20	16.0	-13.44	2.56	No
	802.11n HT40	15.5	-13.44	2.06	No
WLAN 5.6G	802.11a	17.0	-3.15	13.85	No
	802.11n HT20	16.0	-13.44	2.56	No
	802.11n HT40	16.5	-13.44	3.06	No
WLAN 5.8G	802.11a	18.0	-3.15	14.85	No
	802.11n HT20	17.0	-13.44	3.56	No
	802.11n HT40	17.0	-13.44	3.56	No

Note:

1. The EDGE data modes were considered but not tested because GSM voice mode was worst case for the GSM air interface.
2. The TDD-LTE 16QAM/64QAM data modes were considered but not tested because QPSK mode was worst case for the TDD-LTE air interface.

4.6 Measured Conducted Power Results

The measuring conducted average power (Unit: dBm) are shown as below.

Band	GSM850			GSM1900		
Channel	128	189	251	512	661	810
Frequency (MHz)	824.2	836.4	848.8	1850.2	1880.0	1909.8
GSM (GMSK, 1 Tx Slot)	31.82	31.75	31.84	29.35	29.30	29.20

Band	LTE Band 41							
BW	Modulation	RB Size	RB Offset	Low	Low-Mid	Mid	High-Mid	High
		Channel		39750	40185	40620	41055	41490
		Frequency (MHz)		2506	2549.5	2593	2636.5	2680
20M	QPSK	1	0	22.18	22.17	22.35	22.22	22.19
		1	50	22.09	22.12	22.31	22.10	22.17
		1	99	21.45	21.48	21.67	21.46	21.47
		50	0	21.11	21.14	21.40	21.18	21.22
		50	25	21.16	21.17	21.36	21.21	21.16
		50	50	20.95	20.98	21.25	21.03	21.07
		100	0	21.08	21.07	21.30	21.11	21.10

4.7 HAC RF Emission Testing Results

Plot No.	Band	Mode	Channel	Audio Interference Level (dB V/m)	FCC Limit (dB V/m)	FCC Margin (dB)	M-Rating
P01	GSM850	Voice	128	32.3	45	12.7	M4
P02	GSM850	Voice	189	31.7	45	13.3	M4
P03	GSM850	Voice	251	31.05	45	13.95	M4
P04	GSM1900	Voice	512	22.86	35	12.14	M4
P05	GSM1900	Voice	661	23.11	35	11.89	M4
P06	GSM1900	Voice	810	22.81	35	12.19	M4
P07	LTE Band 41	20M_QPSK_1_0	39750	24.81	35	10.19	M4
P08	LTE Band 41	20M_QPSK_1_0	40185	24.31	35	10.69	M4
P09	LTE Band 41	20M_QPSK_1_0	40620	23.39	35	11.61	M4
P10	LTE Band 41	20M_QPSK_1_0	41055	23.75	35	11.25	M4
P11	LTE Band 41	20M_QPSK_1_0	41490	23.28	35	11.72	M4

Test Engineer:



FCC HAC (RF Emission) Test Report

5. Calibration of Test Equipment

Equipment	Manufacturer	Model	SN	Cal. Date	Cal. Interval
835MHz Calibration Dipole	SPEAG	CD835V3	1213	Sep.17,2020	3 Years
1880MHz Calibration Dipole	SPEAG	CD1880V3	1203	Sep.17,2020	3 Years
2600MHz Calibration Dipole	SPEAG	CD2600V3	1026	Sep.17,2020	3 Years
Isotropic E-Field Probe	SPEAG	EF3DV3	4075	Sep.28,2020	1 Year
Data Acquisition Electronics	SPEAG	DAE4	1633	Sep.28,2020	1 Year
Universal Radio Communication Tester	R&S	CMW500	169210	Oct.18,2020	1 Year
Wireless Communication Analyzer	Agilent	E5515C	MY50260600	Jun.02,2021	1 Year
ENA Series Network Analyzer	Agilent	E5071C	MY46214638	Jun.03,2021	1 Year
Spectrum Analyzer	KEYSIGHT	N9010A	MY54510355	Jun.03,2021	1 Year
MXG Analog Signal Generator	KEYSIGHT	N5183A	MY50143024	Jun.09,2021	1 Year
Power Meter	Agilent	N1914A	MY52180044	Mar,02,2021	1 Year
Power Sensor	Agilent	E9304AH18	MY52050011	Feb.25,2021	1 Year
Power Meter	ANRITSU	ML2495A	1506002	Apr.07,2021	1 Year
Power Sensor	ANRITSU	MA4211B	1339353	May.07,2021	1 Year
Temp.& Humi.Recorder	CLOCK	HTC-1	157248	Jun.02,2021	1 Year
Electronic Thermometer	YONGFA	YF-160A	120100323	Jun.02,2021	1 Year
Coupler	Woken	0110A056020-10	COM27RW1A	Jun.02,2021	1 Year
Test Arch Phantom	SPEAG	Arch	N/A	N/A	N/A

6. Measurement Uncertainty

HAC Uncertainty Budget for RF 2011 version According to ANSI C63.19						
Error Description	Uncertainty Value (±%)	Probability	Divisor	(Ci) E	(Ci) H	Standard Uncertainty (E) (±%)
Measurement System						
Probe Calibration	5.1	N	1	1	1	5.1
Axial Isotropy	4.7	R	1.732	1	1	2.7
Sensor Displacement	16.5	R	1.732	1	0.145	9.5
Boundary Effects	2.4	R	1.732	1	1	1.4
Phantom Boundary Effect	7.2	R	1.732	1	0	4.2
Linearity	4.7	R	1.732	1	1	2.7
Scaling with PMR calibration	10.0	R	1.732	1	1	5.8
System Detection Limit	1.0	R	1.732	1	1	0.6
Readout Electronics	0.3	N	1	1	1	0.3
Response Time	2.6	R	1.732	1	1	1.5
Integration Time	2.6	R	1.732	1	1	1.5
RF Ambient Conditions	3.0	R	1.732	1	1	1.7
RF Reflections	12.0	R	1.732	1	1	6.9
Probe Positioner	1.2	R	1.732	1	0.67	0.7
Probe Positioning	4.7	R	1.732	1	0.67	2.7
Extrap. and Interpolation	1.0	R	1.732	1	1	0.6
Test Sample Related						
Device Positioning Vertical	4.7	R	1.732	1	0.67	2.7
Device Positioning Lateral	1.0	R	1.732	1	1	0.6
Device Holder and Phantom	2.4	R	1.732	1	1	1.4
Power Drift	5.0	R	1.732	1	1	2.9
Phantom and Setup Related						
Phantom Thickness	2.4	R	1.732	1	0.67	1.4
Combined Std. Uncertainty						16.4%
Coverage Factor for 95 %						K=2
Expanded STD Uncertainty						32.7%

Uncertainty budget for HAC RF Emission

7. Information of the Testing Laboratories

We, BV 7LAYERS COMMUNICATIONS TECHNOLOGY (SHENZHEN) CO. LTD., were founded in 2015 to provide our best service in EMC, Radio, Telecom and Safety consultation. Our laboratories are accredited and approved according to ISO/IEC 17025.

If you have any comments, please feel free to contact us at the following:

Add: No. B102, Dazu Chuangxin Mansion, North of Beihuan Avenue, North Area, Hi-Tech Industry Park, Nanshan District, Shenzhen, Guangdong, China

Tel: 86-755-8869-6566

Fax: 86-755-8869-6577

Email: customerservice.dg@cn.bureauveritas.com

Web Site: www.bureauveritas.com

The road map of all our labs can be found in our web site also.

---END---



BUREAU
VERITAS

FCC HAC (RF Emission) Test Report

Appendix A. Plots of System Verification

System Cheek_E-Field_835_210815

DUT: HAC Dipole 835 MHz; Type: CD835V; SN: 1213

Communication System: CW; Frequency: 835 MHz; Duty Cycle: 1:1

Medium: Air Medium parameters used: $\sigma = 0 \text{ S/m}$, $\epsilon_r = 1$; $\rho = 0 \text{ kg/m}^3$

Ambient Temperature : 23.3°C

DASY5 Configuration:

- Probe: EF3DV3 - SN4075; ConvF(1, 1, 1) @ 835 MHz; Calibrated: 9/28/2020
- Sensor-Surface: (Fix Surface)
- Electronics: DAE4 Sn1633; Calibrated: 9/28/2020
- Phantom: HAC Test Arch with AMCC; Type: SD HAC P01 BA;
- Measurement SW: DASY52, Version 52.10 (4); SEMCAD X Version 14.6.14 (7483)

E Scan - measurement distance from the probe sensor center to CD835 = 10mm & 15mm/Hearing Aid Compatibility Test at 15mm distance (41x361x1): Interpolated grid:

dx=0.5000 mm, dy=0.5000 mm

Device Reference Point: 0, 0, -6.3 mm

Reference Value = 129.9 V/m; Power Drift = 0.06 dB

PMR not calibrated. PMF = 1.000 is applied.

E-field emissions = 122.9 V/m

Average value of Total=(104.0+122.9) / 2 = 113.45 V/m

PMF scaled E-field

Grid 1 M4 100.6 V/m	Grid 2 M4 104.0 V/m	Grid 3 M4 103.4 V/m
Grid 4 M4 62.44 V/m	Grid 5 M4 63.74 V/m	Grid 6 M4 62.73 V/m
Grid 7 M4 119.9 V/m	Grid 8 M4 122.9 V/m	Grid 9 M4 119.7 V/m

Cursor:

Total = 122.9 V/m

E Category: M4

Location: 0, 73.5, 8.7 mm

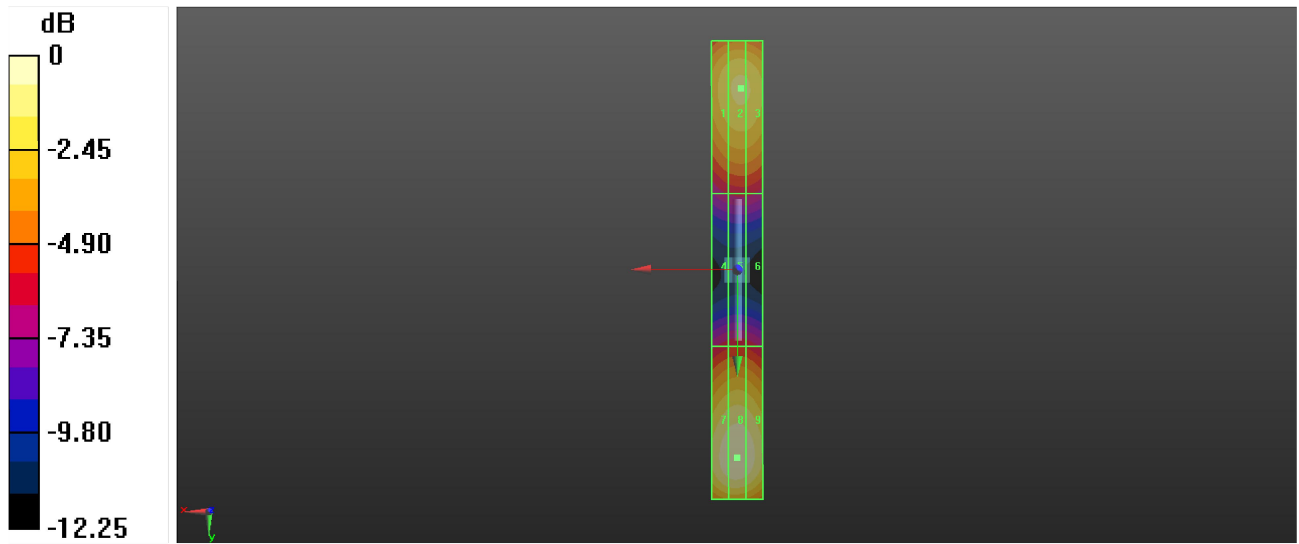

0 dB = 122.9 V/m = 41.79 dBV/m

System Cheek_E-Field_1880_210815

DUT: HAC Dipole 1880 MHz; Type: CD1880V; SN: 1203

Communication System: CW; Frequency: 1880 MHz; Duty Cycle: 1:1

Medium: Air Medium parameters used: $\sigma = 0$ S/m, $\epsilon_r = 1$; $\rho = 0$ kg/m³

Ambient Temperature : 23.3°C

DASY5 Configuration:

- Probe: EF3DV3 - SN4075; ConvF(1, 1, 1) @ 1880 MHz; Calibrated: 9/28/2020
- Sensor-Surface: (Fix Surface)
- Electronics: DAE4 Sn1633; Calibrated: 9/28/2020
- Phantom: HAC Test Arch with AMCC; Type: SD HAC P01 BA;
- Measurement SW: DASY52, Version 52.10 (4); SEMCAD X Version 14.6.14 (7483)

E Scan - measurement distance from the probe sensor center to CD1880 = 10mm & 15mm 2/Hearing Aid Compatibility Test at 15mm distance (41x181x1): Interpolated

grid: dx=0.5000 mm, dy=0.5000 mm

Device Reference Point: 0, 0, -6.3 mm

Reference Value = 142.8 V/m; Power Drift = 0.00 dB

PMR not calibrated. PMF = 1.000 is applied.

E-field emissions = 92.02 V/m

Average value of Total=(92.02+89.53) / 2 = 90.78 V/m

PMF scaled E-field

Grid 1 M3 88.84 V/m	Grid 2 M3 92.02 V/m	Grid 3 M3 91.15 V/m
Grid 4 M4 61.60 V/m	Grid 5 M4 62.50 V/m	Grid 6 M4 62.17 V/m
Grid 7 M3 88.12 V/m	Grid 8 M3 89.53 V/m	Grid 9 M3 87.67 V/m

Cursor:

Total = 92.02 V/m

E Category: M3

Location: -1, -34, 8.7 mm

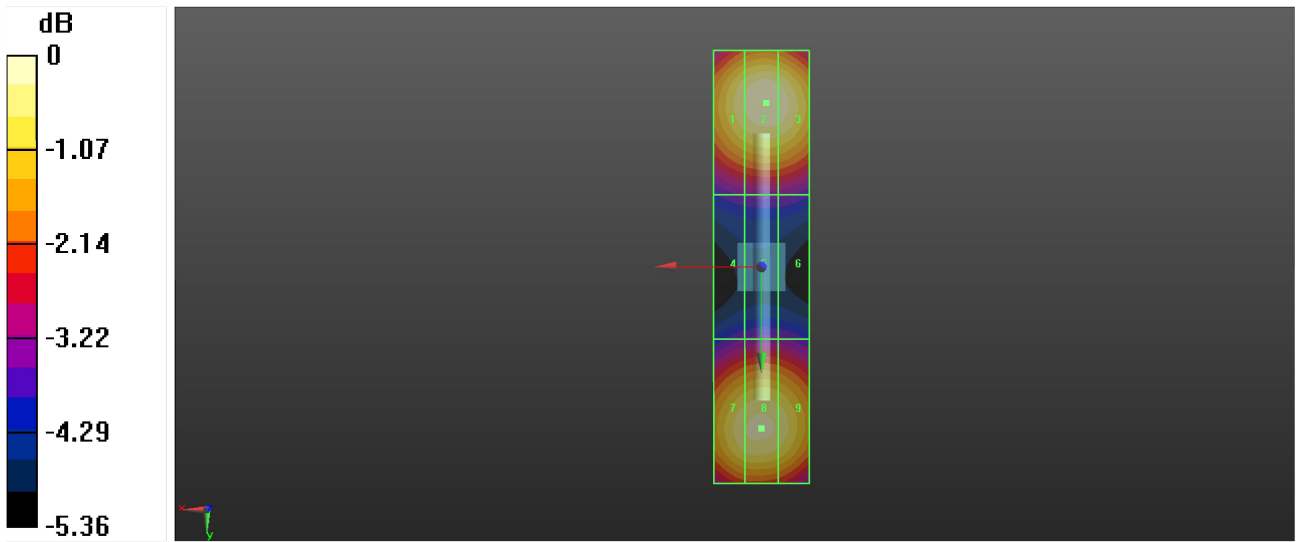

System Cheek_E-Field_2600_210815

DUT: HAC Dipole 2600 MHz; Type: CD2600V; SN: 1026

Communication System: CW; Frequency: 2600 MHz; Duty Cycle: 1:1

Medium: Air Medium parameters used: $\sigma = 0$ S/m, $\epsilon_r = 1$; $\rho = 0$ kg/m³

Ambient Temperature : 23.3°C

DASY5 Configuration:

- Probe: EF3DV3 - SN4075; ConvF(1, 1, 1) @ 2600 MHz; Calibrated: 9/28/2020
- Sensor-Surface: (Fix Surface)
- Electronics: DAE4 Sn1633; Calibrated: 9/28/2020
- Phantom: HAC Test Arch with AMCC; Type: SD HAC P01 BA;
- Measurement SW: DASY52, Version 52.10 (4); SEMCAD X Version 14.6.14 (7483)

E Scan - measurement distance from the probe sensor center to CD2600 = 10mm & 15mm 2 2/Hearing Aid Compatibility Test at 15mm distance (41x181x1): Interpolated

grid: dx=0.5000 mm, dy=0.5000 mm

Device Reference Point: 0, 0, -6.3 mm

Reference Value = 69.94 V/m; Power Drift = 0.01 dB

PMR not calibrated. PMF = 1.000 is applied.

E-field emissions = 86.61 V/m

Average value of Total=(84.93+86.61) / 2 = 85.77 V/m

PMF scaled E-field

Grid 1 M3 83.12 V/m	Grid 2 M3 84.93 V/m	Grid 3 M3 84.09 V/m
Grid 4 M3 78.93 V/m	Grid 5 M3 80.12 V/m	Grid 6 M3 79.87 V/m
Grid 7 M3 84.76 V/m	Grid 8 M3 86.61 V/m	Grid 9 M3 85.12 V/m

Cursor:

Total = 86.61 V/m

E Category: M3

Location: 0, 23.5, 8.7 mm

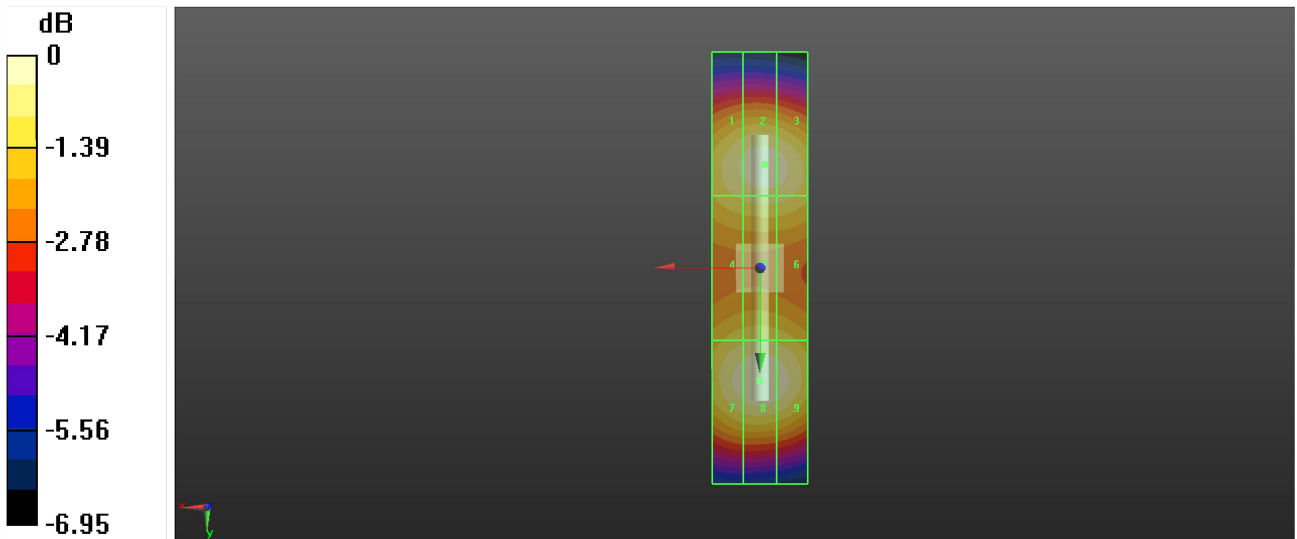

0 dB = 86.61 V/m = 38.75 dBV/m



BUREAU
VERITAS

FCC HAC (RF Emission) Test Report

Appendix B. Plots of HAC RF Emission Measurement

P01 RF_E_Field_GSM850_GSM_Ch128

Communication System: GSM; Frequency: 824.2 MHz; Duty Cycle: 1:8.3

Medium: Air Medium parameters used: $\sigma = 0$ S/m, $\epsilon_r = 1$; $\rho = 0$ kg/m³

Ambient Temperature : 23.3°C

DASY5 Configuration:

- Probe: EF3DV3 - SN4075; ConvF(1, 1, 1) @ 824.2 MHz; Calibrated: 9/28/2020
- Sensor-Surface: (Fix Surface)
- Electronics: DAE4 Sn1633; Calibrated: 9/28/2020
- Phantom: HAC Test Arch with AMCC; Type: SD HAC P01 BA;
- Measurement SW: DASY52, Version 52.10 (4); SEMCAD X Version 14.6.14 (7483)

Hearing Aid Compatibility (101x101x1): Interpolated grid: dx=0.5000 mm, dy=0.5000 mm

Device Reference Point: 0, 0, -6.3 mm

Reference Value = 50.48 V/m; Power Drift = 0.02 dB

Applied MIF = 3.63 dB

RF audio interference level = 32.30 dBV/m

Emission category: M4

Grid 1 31.12 dBV/m	Grid 2 32.21 dBV/m	Grid 3 32.2 dBV/m
Grid 4 31.06 dBV/m	Grid 5 32.3 dBV/m	Grid 6 32.28 dBV/m
Grid 7 30.67 dBV/m	Grid 8 31.95 dBV/m	Grid 9 31.94 dBV/m

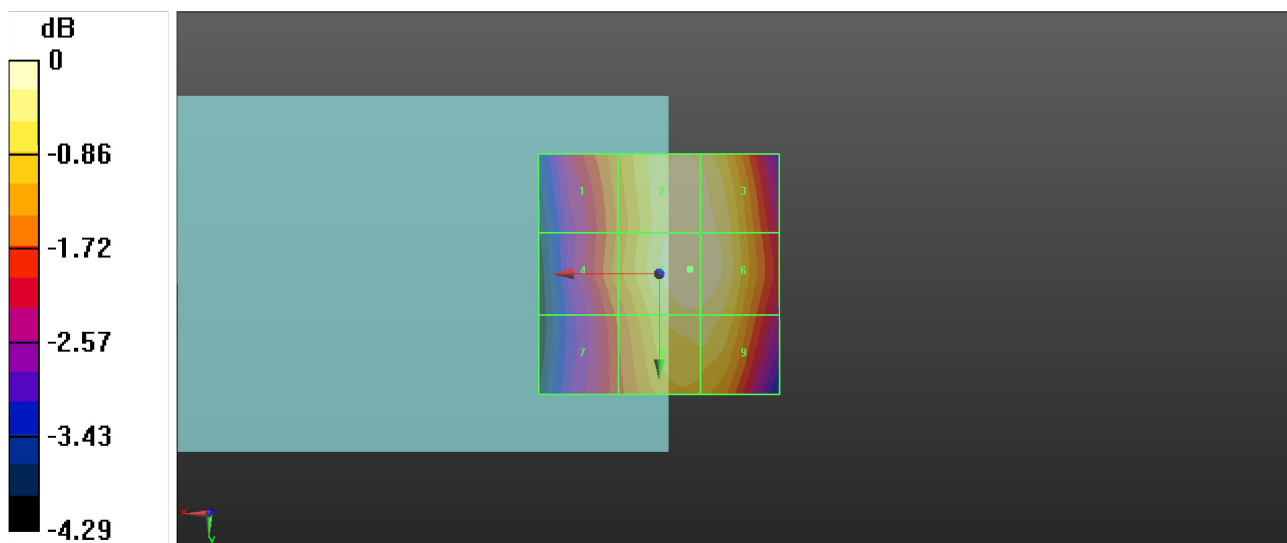

0 dB = 41.19 V/m = 32.30 dBV/m

P02 RF_E_Field_GSM850_GSM_Ch189

Communication System: GSM; Frequency: 836.4 MHz; Duty Cycle: 1:8.3

Medium: Air Medium parameters used: $\sigma = 0 \text{ S/m}$, $\epsilon_r = 1$; $\rho = 0 \text{ kg/m}^3$

Ambient Temperature : 23.3°C

DASY5 Configuration:

- Probe: EF3DV3 - SN4075; ConvF(1, 1, 1) @ 836.6 MHz; Calibrated: 9/28/2020
- Sensor-Surface: (Fix Surface)
- Electronics: DAE4 Sn1633; Calibrated: 9/28/2020
- Phantom: HAC Test Arch with AMCC; Type: SD HAC P01 BA;
- Measurement SW: DASY52, Version 52.10 (4); SEMCAD X Version 14.6.14 (7483)

Hearing Aid Compatibility (101x101x1): Interpolated grid: dx=0.5000 mm, dy=0.5000 mm

Device Reference Point: 0, 0, -6.3 mm

Reference Value = 47.32 V/m; Power Drift = -0.03 dB

Applied MIF = 3.63 dB

RF audio interference level = 31.70 dBV/m

Emission category: M4

Grid 1 30.71 dBV/m	Grid 2 31.7 dBV/m	Grid 3 31.66 dBV/m
Grid 4 30.47 dBV/m	Grid 5 31.69 dBV/m	Grid 6 31.68 dBV/m
Grid 7 30.03 dBV/m	Grid 8 31.3 dBV/m	Grid 9 31.29 dBV/m

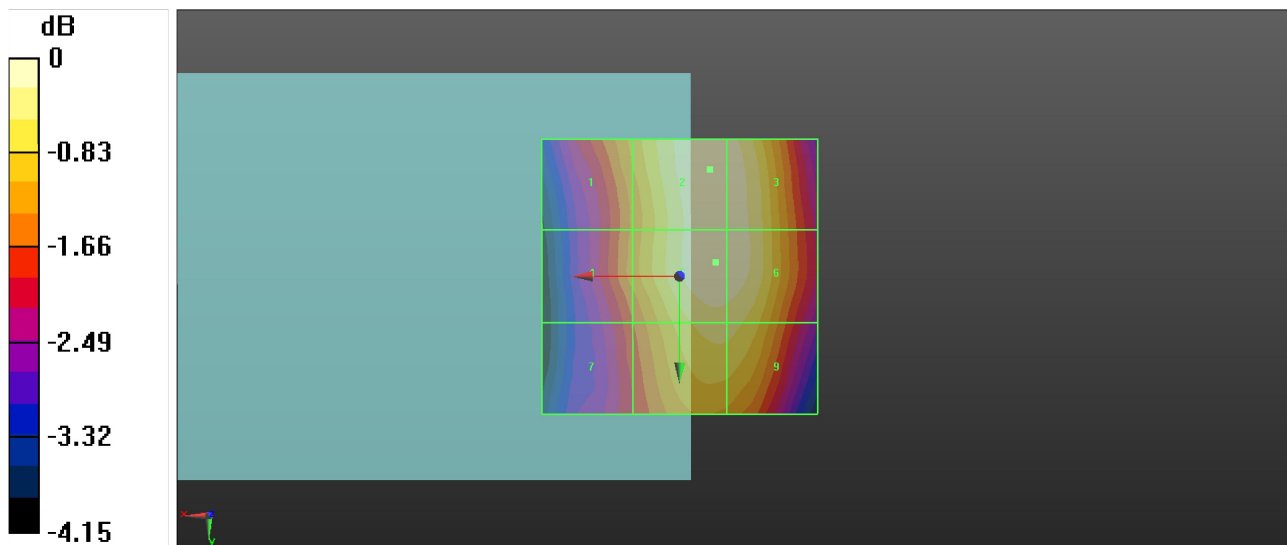

0 dB = 38.48 V/m = 31.70 dBV/m

P03 RF_E_Field_GSM850_GSM_Ch251

Communication System: GSM; Frequency: 848.8 MHz; Duty Cycle: 1:8.3

Medium: Air Medium parameters used: $\sigma = 0 \text{ S/m}$, $\epsilon_r = 1$; $\rho = 0 \text{ kg/m}^3$

Ambient Temperature : 23.3°C

DASY5 Configuration:

- Probe: EF3DV3 - SN4075; ConvF(1, 1, 1) @ 848.8 MHz; Calibrated: 9/28/2020
- Sensor-Surface: (Fix Surface)
- Electronics: DAE4 Sn1633; Calibrated: 9/28/2020
- Phantom: HAC Test Arch with AMCC; Type: SD HAC P01 BA;
- Measurement SW: DASY52, Version 52.10 (4); SEMCAD X Version 14.6.14 (7483)

Hearing Aid Compatibility (101x101x1): Interpolated grid: dx=0.5000 mm, dy=0.5000 mm

Device Reference Point: 0, 0, -6.3 mm

Reference Value = 43.62 V/m; Power Drift = 0.12 dB

Applied MIF = 3.63 dB

RF audio interference level = 31.05 dBV/m

Emission category: M4

Grid 1 29.77 dBV/m	Grid 2 30.99 dBV/m	Grid 3 30.99 dBV/m
Grid 4 29.78 dBV/m	Grid 5 31.05 dBV/m	Grid 6 31.05 dBV/m
Grid 7 29.51 dBV/m	Grid 8 30.73 dBV/m	Grid 9 30.73 dBV/m

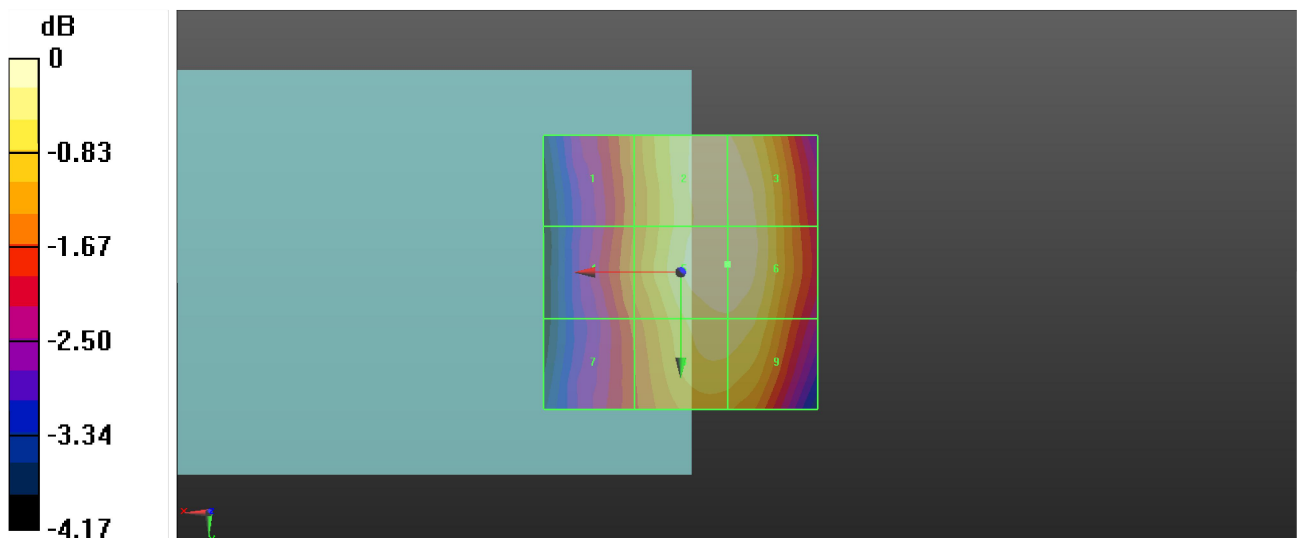

0 dB = 35.69 V/m = 31.05 dBV/m

P04 RF_E_Field_GSM1900_GSM_Ch512

Communication System: GSM; Frequency: 1850.2 MHz; Duty Cycle: 1:8.3

Medium: Air Medium parameters used: $\sigma = 0 \text{ S/m}$, $\epsilon_r = 1$; $\rho = 0 \text{ kg/m}^3$

Ambient Temperature : 23.3°C

DASY5 Configuration:

- Probe: EF3DV3 - SN4075; ConvF(1, 1, 1) @ 1850.2 MHz; Calibrated: 9/28/2020
- Sensor-Surface: (Fix Surface)
- Electronics: DAE4 Sn1633; Calibrated: 9/28/2020
- Phantom: HAC Test Arch with AMCC; Type: SD HAC P01 BA;
- Measurement SW: DASY52, Version 52.10 (4); SEMCAD X Version 14.6.14 (7483)

Hearing Aid Compatibility (101x101x1): Interpolated grid: dx=0.5000 mm, dy=0.5000 mm

Device Reference Point: 0, 0, -6.3 mm

Reference Value = 13.77 V/m; Power Drift = -0.05 dB

Applied MIF = 3.63 dB

RF audio interference level = 22.86 dBV/m

Emission category: M4

Grid 1 19.93 dBV/m	Grid 2 22.55 dBV/m	Grid 3 22.85 dBV/m
Grid 4 17.03 dBV/m	Grid 5 22.55 dBV/m	Grid 6 22.86 dBV/m
Grid 7 20.23 dBV/m	Grid 8 21.06 dBV/m	Grid 9 21.66 dBV/m

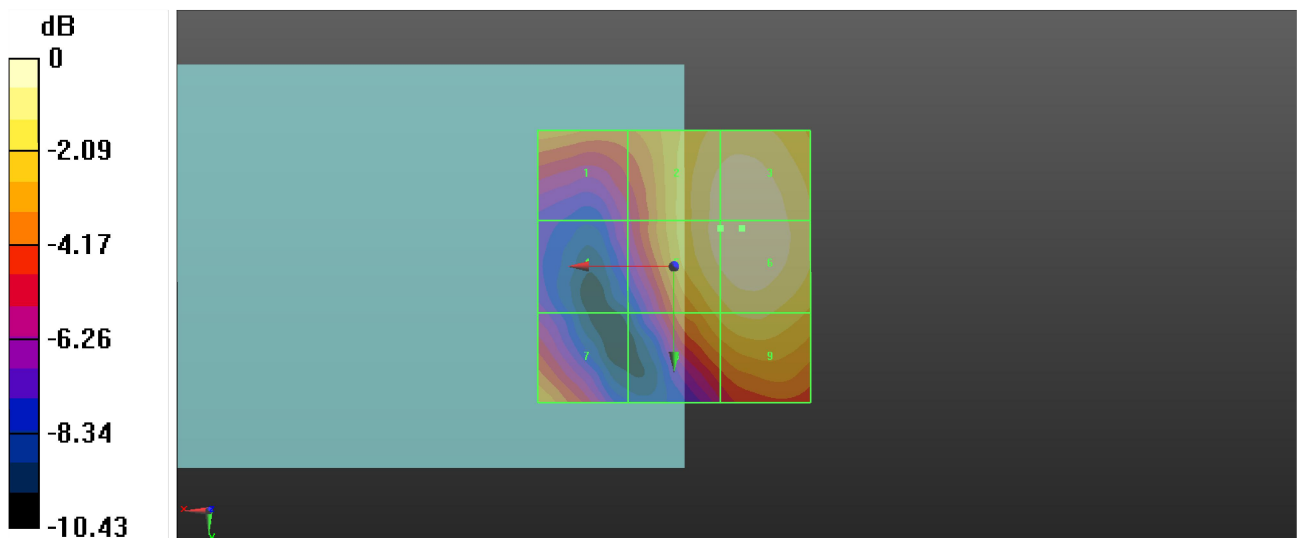

0 dB = 13.90 V/m = 22.86 dBV/m

P05 RF_E_Field_GSM1900_GSM_Ch661

Communication System: GSM; Frequency: 1880 MHz; Duty Cycle: 1:8.3

Medium: Air Medium parameters used: $\sigma = 0$ S/m, $\epsilon_r = 1$; $\rho = 0$ kg/m³

Ambient Temperature : 23.3°C

DASY5 Configuration:

- Probe: EF3DV3 - SN4075; ConvF(1, 1, 1) @ 1880 MHz; Calibrated: 9/28/2020
- Sensor-Surface: (Fix Surface)
- Electronics: DAE4 Sn1633; Calibrated: 9/28/2020
- Phantom: HAC Test Arch with AMCC; Type: SD HAC P01 BA;
- Measurement SW: DASY52, Version 52.10 (4); SEMCAD X Version 14.6.14 (7483)

Hearing Aid Compatibility (101x101x1): Interpolated grid: dx=0.5000 mm, dy=0.5000 mm

Device Reference Point: 0, 0, -6.3 mm

Reference Value = 12.98 V/m; Power Drift = 0.07 dB

Applied MIF = 3.63 dB

RF audio interference level = 23.11 dBV/m

Emission category: M4

Grid 1 18.75 dBV/m	Grid 2 22.4 dBV/m	Grid 3 22.99 dBV/m
Grid 4 18.31 dBV/m	Grid 5 22.54 dBV/m	Grid 6 23.11 dBV/m
Grid 7 22.34 dBV/m	Grid 8 21.41 dBV/m	Grid 9 22.06 dBV/m

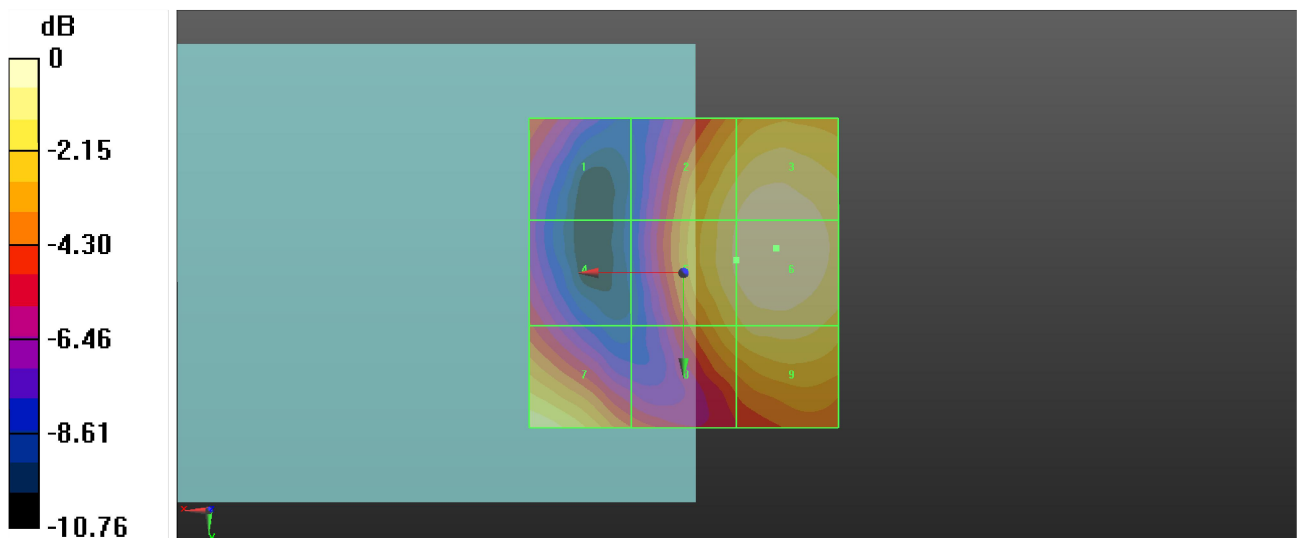

0 dB = 14.31 V/m = 23.11 dBV/m

P06 RF_E_Field_GSM1900_GSM_Ch810

Communication System: GSM; Frequency: 1909.8 MHz; Duty Cycle: 1:8.3

Medium: Air Medium parameters used: $\sigma = 0 \text{ S/m}$, $\epsilon_r = 1$; $\rho = 0 \text{ kg/m}^3$

Ambient Temperature : 23.3°C

DASY5 Configuration:

- Probe: EF3DV3 - SN4075; ConvF(1, 1, 1) @ 1909.8 MHz; Calibrated: 9/28/2020
- Sensor-Surface: (Fix Surface)
- Electronics: DAE4 Sn1633; Calibrated: 9/28/2020
- Phantom: HAC Test Arch with AMCC; Type: SD HAC P01 BA;
- Measurement SW: DASY52, Version 52.10 (4); SEMCAD X Version 14.6.14 (7483)

Hearing Aid Compatibility (101x101x1): Interpolated grid: dx=0.5000 mm, dy=0.5000 mm

Device Reference Point: 0, 0, -6.3 mm

Reference Value = 14.13 V/m; Power Drift = 0.25 dB

Applied MIF = 3.63 dB

RF audio interference level = 22.81 dBV/m

Emission category: M4

Grid 1 18.6 dBV/m	Grid 2 21.11 dBV/m	Grid 3 21.46 dBV/m
Grid 4 16.42 dBV/m	Grid 5 22.44 dBV/m	Grid 6 22.81 dBV/m
Grid 7 20.89 dBV/m	Grid 8 22.33 dBV/m	Grid 9 22.72 dBV/m

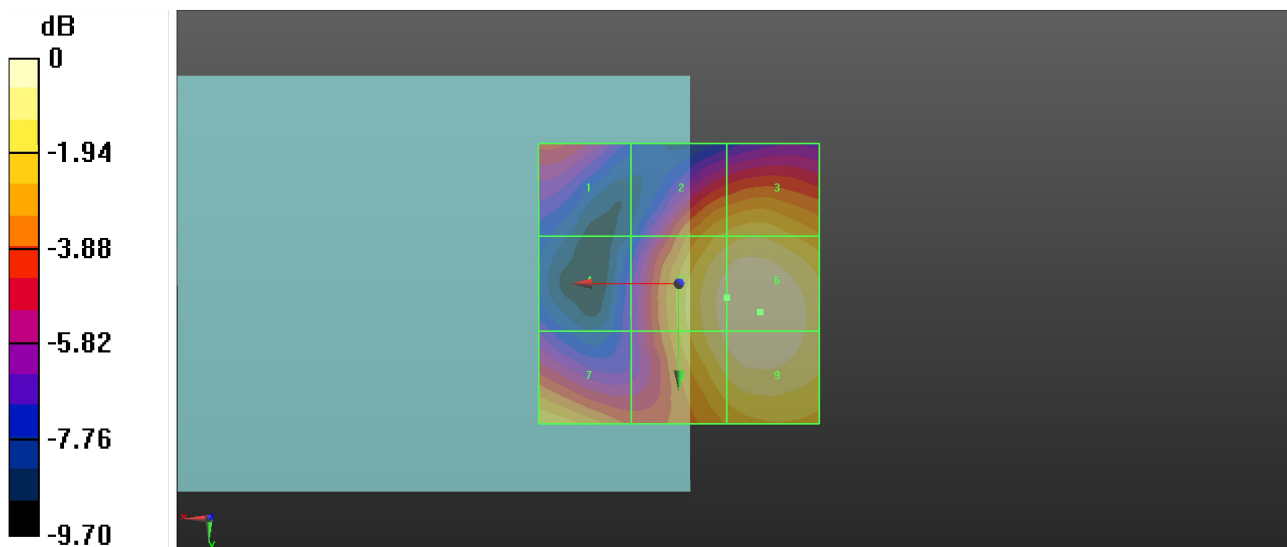

0 dB = 13.81 V/m = 22.81 dBV/m

P07 RF_E_Field_LTE 41_QPSK20M_Ch39750_1RB_OS0

Communication System: LTE; Frequency: 2506 MHz; Duty Cycle: 1:1.59

Medium: Air Medium parameters used: $\sigma = 0$ S/m, $\epsilon_r = 1$; $\rho = 0$ kg/m³

Ambient Temperature : 23.3°C

DASY5 Configuration:

- Probe: EF3DV3 - SN4075; ConvF(1, 1, 1) @ 2506 MHz; Calibrated: 9/28/2020
- Sensor-Surface: (Fix Surface)
- Electronics: DAE4 Sn1633; Calibrated: 9/28/2020
- Phantom: HAC Test Arch with AMCC; Type: SD HAC P01 BA;
- Measurement SW: DASY52, Version 52.10 (4); SEMCAD X Version 14.6.14 (7483)

Hearing Aid Compatibility (101x101x1): Interpolated grid: dx=0.5000 mm, dy=0.5000 mm

Device Reference Point: 0, 0, -6.3 mm

Reference Value = 9.748 V/m; Power Drift = -0.80 dB

Applied MIF = -1.44 dB

RF audio interference level = 24.81 dBV/m

Emission category: M4

Grid 1 24.81 dBV/m	Grid 2 22.84 dBV/m	Grid 3 20.04 dBV/m
Grid 4 21.54 dBV/m	Grid 5 21.7 dBV/m	Grid 6 21.9 dBV/m
Grid 7 24.38 dBV/m	Grid 8 21.84 dBV/m	Grid 9 22.03 dBV/m

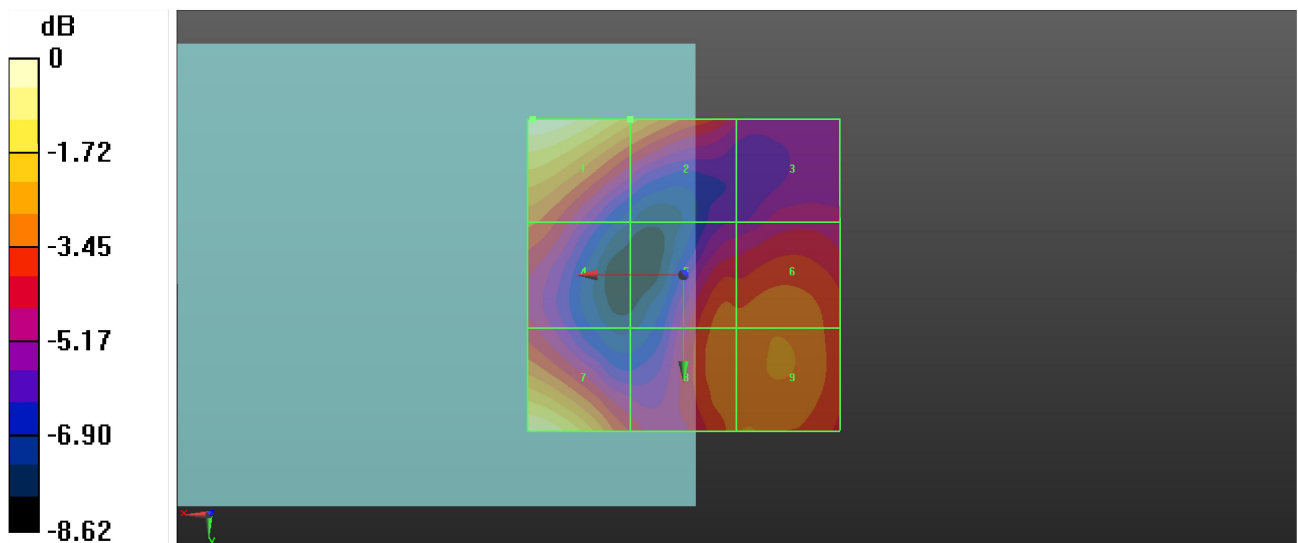

0 dB = 17.40 V/m = 24.81 dBV/m

P08 RF_E_Field_LTE 41_QPSK20M_Ch40185_1RB_OS0

Communication System: LTE; Frequency: 2549.5 MHz; Duty Cycle: 1:1.59

Medium: Air Medium parameters used: $\sigma = 0$ S/m, $\epsilon_r = 1$; $\rho = 0$ kg/m³

Ambient Temperature : 23.3°C

DASY5 Configuration:

- Probe: EF3DV3 - SN4075; ConvF(1, 1, 1) @ 2549.5 MHz; Calibrated: 9/28/2020
- Sensor-Surface: (Fix Surface)
- Electronics: DAE4 Sn1633; Calibrated: 9/28/2020
- Phantom: HAC Test Arch with AMCC; Type: SD HAC P01 BA;
- Measurement SW: DASY52, Version 52.10 (4); SEMCAD X Version 14.6.14 (7483)

Hearing Aid Compatibility (101x101x1): Interpolated grid: dx=0.5000 mm, dy=0.5000 mm

Device Reference Point: 0, 0, -6.3 mm

Reference Value = 7.968 V/m; Power Drift = -0.00 dB

Applied MIF = -1.44 dB

RF audio interference level = 24.31 dBV/m

Emission category: M4

Grid 1 21.71 dBV/m	Grid 2 21.68 dBV/m	Grid 3 20.53 dBV/m
Grid 4 20.59 dBV/m	Grid 5 22.43 dBV/m	Grid 6 23.54 dBV/m
Grid 7 24.31 dBV/m	Grid 8 23.14 dBV/m	Grid 9 23.93 dBV/m

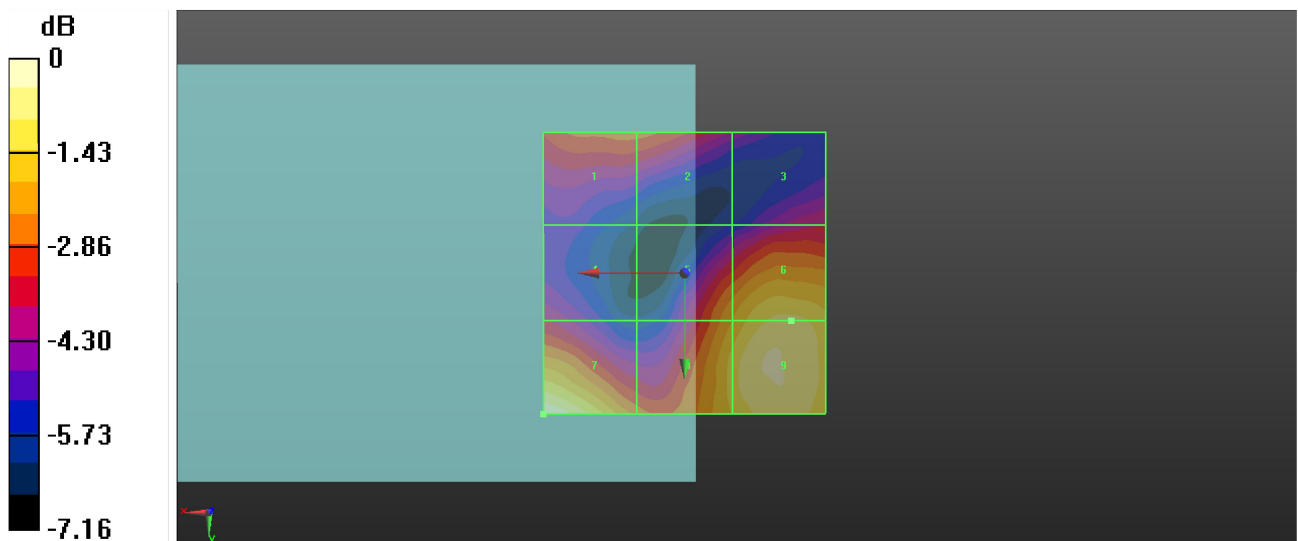

0 dB = 16.43 V/m = 24.31 dBV/m

P09 RF_E_Field_LTE 41_QPSK20M_Ch40620_1RB_OS0

Communication System: LTE; Frequency: 2593 MHz; Duty Cycle: 1:1.59

Medium: Air Medium parameters used: $\sigma = 0 \text{ S/m}$, $\epsilon_r = 1$; $\rho = 0 \text{ kg/m}^3$

Ambient Temperature : 23.3°C

DASY5 Configuration:

- Probe: EF3DV3 - SN4075; ConvF(1, 1, 1) @ 2593 MHz; Calibrated: 9/28/2020
- Sensor-Surface: (Fix Surface)
- Electronics: DAE4 Sn1633; Calibrated: 9/28/2020
- Phantom: HAC Test Arch with AMCC; Type: SD HAC P01 BA;
- Measurement SW: DASY52, Version 52.10 (4); SEMCAD X Version 14.6.14 (7483)

Hearing Aid Compatibility (101x101x1): Interpolated grid: dx=0.5000 mm, dy=0.5000 mm

Device Reference Point: 0, 0, -6.3 mm

Reference Value = 5.503 V/m; Power Drift = 0.03 dB

Applied MIF = -1.44 dB

RF audio interference level = 23.39 dBV/m

Emission category: M4

Grid 1 21.63 dBV/m	Grid 2 21 dBV/m	Grid 3 19.87 dBV/m
Grid 4 20.96 dBV/m	Grid 5 20.51 dBV/m	Grid 6 22.01 dBV/m
Grid 7 23.39 dBV/m	Grid 8 21.8 dBV/m	Grid 9 22.78 dBV/m

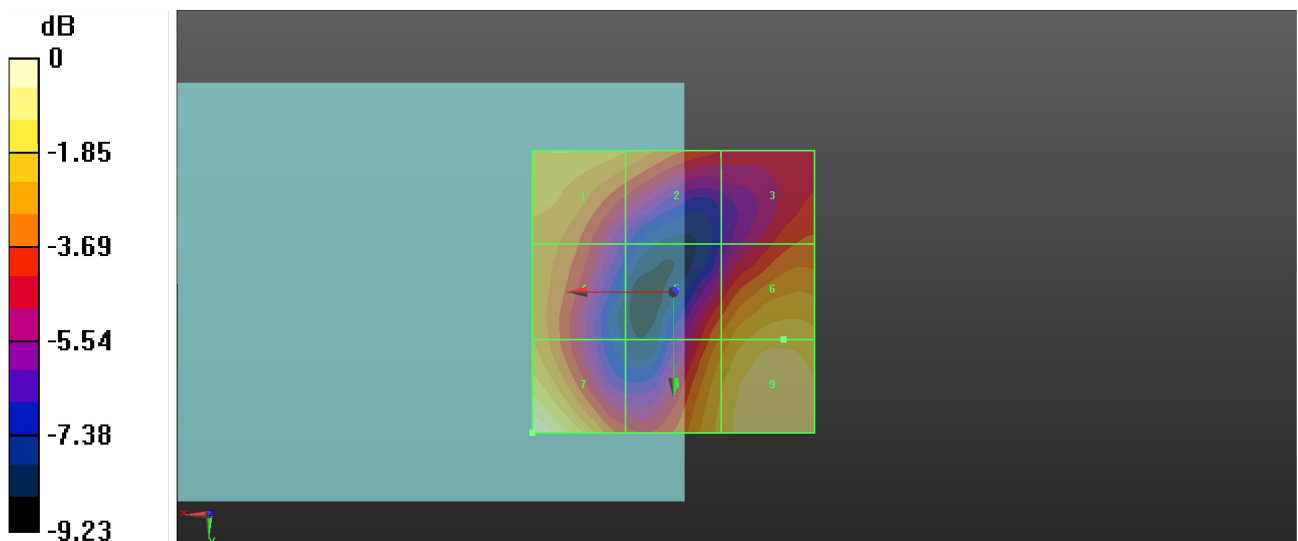

0 dB = 14.78 V/m = 23.39 dBV/m

P10 RF_E_Field_LTE 41_QPSK20M_Ch41055_1RB_OS0

Communication System: LTE TDD; Frequency: 2636.5 MHz; Duty Cycle: 1:1.59

Medium: Air Medium parameters used: $\sigma = 0 \text{ S/m}$, $\epsilon_r = 1$; $\rho = 0 \text{ kg/m}^3$

Ambient Temperature : 23.3°C

DASY5 Configuration:

- Probe: EF3DV3 - SN4075; ConvF(1, 1, 1) @ 2636.5 MHz; Calibrated: 9/28/2020
- Sensor-Surface: (Fix Surface)
- Electronics: DAE4 Sn1633; Calibrated: 9/28/2020
- Phantom: HAC Test Arch with AMCC; Type: SD HAC P01 BA;
- Measurement SW: DASY52, Version 52.10 (4); SEMCAD X Version 14.6.14 (7483)

Hearing Aid Compatibility (101x101x1): Interpolated grid: dx=0.5000 mm, dy=0.5000 mm

Device Reference Point: 0, 0, -6.3 mm

Reference Value = 4.789 V/m; Power Drift = 0.16 dB

Applied MIF = -1.44 dB

RF audio interference level = 23.75 dBV/m

Emission category: M4

Grid 1 20.61 dBV/m	Grid 2 20.61 dBV/m	Grid 3 19.45 dBV/m
Grid 4 21.52 dBV/m	Grid 5 19.68 dBV/m	Grid 6 21.22 dBV/m
Grid 7 23.75 dBV/m	Grid 8 22.33 dBV/m	Grid 9 23.31 dBV/m

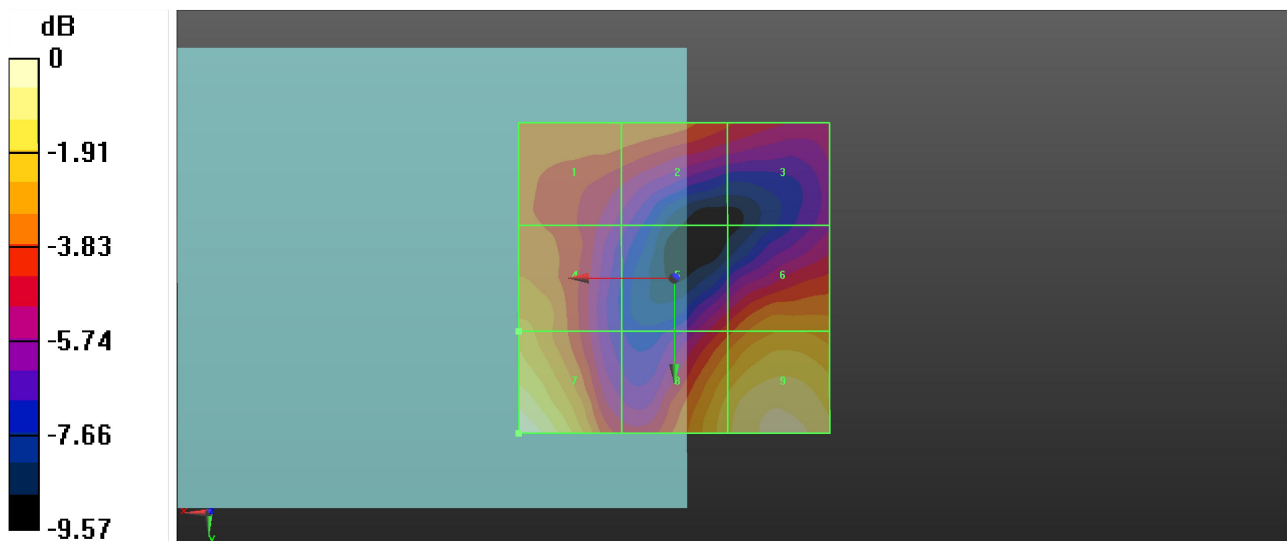

0 dB = 15.41 V/m = 23.75 dBV/m

P11 RF_E_Field_LTE 41_QPSK20M_Ch41490_1RB_OS0

Communication System: LTE TDD; Frequency: 2680 MHz; Duty Cycle: 1:1.59

Medium: Air Medium parameters used: $\sigma = 0 \text{ S/m}$, $\epsilon_r = 1$; $\rho = 0 \text{ kg/m}^3$

Ambient Temperature : 23.3°C

DASY5 Configuration:

- Probe: EF3DV3 - SN4075; ConvF(1, 1, 1) @ 2680 MHz; Calibrated: 9/28/2020
- Sensor-Surface: (Fix Surface)
- Electronics: DAE4 Sn1633; Calibrated: 9/28/2020
- Phantom: HAC Test Arch with AMCC; Type: SD HAC P01 BA;
- Measurement SW: DASY52, Version 52.10 (4); SEMCAD X Version 14.6.14 (7483)

Hearing Aid Compatibility (101x101x1): Interpolated grid: dx=0.5000 mm, dy=0.5000 mm

Device Reference Point: 0, 0, -6.3 mm

Reference Value = 6.804 V/m; Power Drift = 0.13 dB

Applied MIF = -1.44 dB

RF audio interference level = 23.28 dBV/m

Emission category: M4

Grid 1 21.63 dBV/m	Grid 2 21.62 dBV/m	Grid 3 20.03 dBV/m
Grid 4 20.59 dBV/m	Grid 5 19.17 dBV/m	Grid 6 18.83 dBV/m
Grid 7 23.28 dBV/m	Grid 8 20.41 dBV/m	Grid 9 21.21 dBV/m

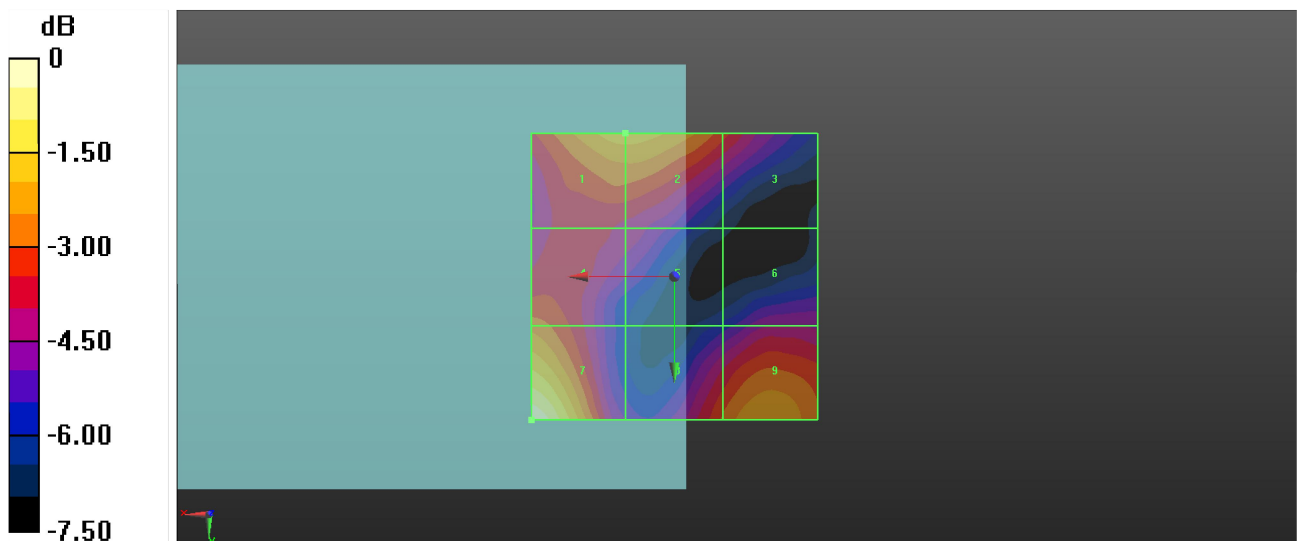

0 dB = 14.59 V/m = 23.28 dBV/m



BUREAU
VERITAS

FCC HAC (RF Emission) Test Report

Appendix C. Calibration Certificate for Probe and Dipole



Accredited by the Swiss Accreditation Service (SAS)
The Swiss Accreditation Service is one of the signatories to the EA
Multilateral Agreement for the recognition of calibration certificates

Accreditation No.: **SCS 0108**

Client **7 layers (Auden)**

Certificate No: **CD835V3-1213_Sep20**

CALIBRATION CERTIFICATE

Object **CD835V3 - SN: 1213**

Calibration procedure(s) **QA CAL-20.v7
Calibration Procedure for Validation Sources in air**

Calibration date: **September 17, 2020**

This calibration certificate documents the traceability to national standards, which realize the physical units of measurements (SI).
The measurements and the uncertainties with confidence probability are given on the following pages and are part of the certificate.

All calibrations have been conducted in the closed laboratory facility: environment temperature (22 ± 3)°C and humidity < 70%.

Calibration Equipment used (M&TE critical for calibration)

Primary Standards	ID #	Cal Date (Certificate No.)	Scheduled Calibration
Power meter NRP	SN: 104778	01-Apr-20 (No. 217-03100/03101)	Apr-21
Power sensor NRP-Z91	SN: 103244	01-Apr-20 (No. 217-03100)	Apr-21
Power sensor NRP-Z91	SN: 103245	01-Apr-20 (No. 217-03101)	Apr-21
Reference 20 dB Attenuator	SN: BH9394 (20k)	31-Mar-20 (No. 217-03106)	Apr-21
Type-N mismatch combination	SN: 310982 / 06327	31-Mar-20 (No. 217-03104)	Apr-21
Probe EF3DV3	SN: 4013	31-Dec-19 (No. EF3-4013_Dec19)	Dec-20
DAE4	SN: 781	27-Dec-19 (No. DAE4-781_Dec19)	Dec-20

Secondary Standards	ID #	Check Date (in house)	Scheduled Check
Power meter Agilent 4419B	SN: GB42420191	09-Oct-09 (in house check Oct-17)	In house check: Oct-20
Power sensor HP E4412A	SN: US38485102	05-Jan-10 (in house check Oct-17)	In house check: Oct-20
Power sensor HP 8482A	SN: US37295597	09-Oct-09 (in house check Oct-17)	In house check: Oct-20
RF generator R&S SMT-06	SN: 837633/005	10-Jan-19 (in house check Jan-19)	In house check: Oct-20
Network Analyzer Agilent E8358A	SN: US41080477	31-Mar-14 (in house check Oct-19)	In house check: Oct-20

	Name	Function	Signature
Calibrated by:	Leif Klysner	Laboratory Technician	
Approved by:	Katja Pokovic	Technical Manager	

Issued: September 24, 2020

This calibration certificate shall not be reproduced except in full without written approval of the laboratory.