

MEASUREMENT REPORT

FCC PART 15.225 / RSS 210 NFC 13.56MHz

FCC ID: HD5-CT40L0N
IC: 1693B-CT40L0N
APPLICANT: Honeywell International Inc
Honeywell Safety and Productivity Solutions
Application Type: Certification
Product: DOLPHIN CT40
Model No.: CT40-L0N
Brand Name: Honeywell
FCC Classification: Part 15 Low Power Communication Device Transmitter (DXX)
FCC Rule Part(s): Part 15.225
IC Rule(s): RSS 210 Issue 9, RSS-GEN Issue 5
Test Procedure(s): ANSI C63.10-2013
Test Date: April 18 ~ June 27, 2018

Reviewed By : Jame Yuan
(Jame Yuan)

Approved By : Robin Wu
(Robin Wu)



The test results relate only to the samples tested.

This equipment has been shown to be capable of compliance with the applicable technical standards as indicated in the measurement report and was tested in accordance with the measurement procedures specified in ANSI C63.10. Test results reported herein relate only to the item(s) tested.

The test report shall not be reproduced except in full without the written approval of MRT Technology (Suzhou) Co., Ltd.

Revision History

| Report No. | Version | Description | Issue Date | Note |
|---------------|---------|----------------|------------|-------|
| 1804RSU010-U6 | Rev. 01 | Initial report | 06-27-2018 | Valid |
| | | | | |

CONTENTS

| Description | Page |
|--|-----------|
| §2.1033 General Information | 5 |
| 1. INTRODUCTION | 6 |
| 1.1. Scope | 6 |
| 1.2. MRT Test Location | 6 |
| 2. PRODUCT INFORMATION | 7 |
| 2.1. Equipment Description..... | 7 |
| 2.2. Test Mode | 7 |
| 2.3. Device Capabilities | 7 |
| 2.4. Test Configuration | 7 |
| 2.5. EMI Suppression Device(s)/Modifications | 8 |
| 2.6. Labeling Requirements | 8 |
| 3. DESCRIPTION OF TEST | 9 |
| 3.1. Evaluation Procedure | 9 |
| 3.2. AC Line Conducted Emissions | 9 |
| 3.3. Radiated Emissions | 10 |
| 4. ANTENNA REQUIREMENTS..... | 11 |
| 5. TEST EQUIPMENT CALIBRATION DATA | 12 |
| 6. MEASUREMENT UNCERTAINTY..... | 13 |
| 7. TEST RESULT | 14 |
| 7.1. Summary | 14 |
| 7.2. In-band Emission..... | 15 |
| 7.2.1. Test Limit | 15 |
| 7.2.2. Test Procedure Used | 15 |
| 7.2.3. Test Setup..... | 16 |
| 7.2.4. Test Result..... | 17 |
| 7.3. Out-band Emission | 18 |
| 7.3.1. Test Limit | 18 |
| 7.3.2. Test Procedure Used | 18 |
| 7.3.3. Test Setup..... | 19 |
| 7.3.4. Test Result..... | 20 |
| 7.4. 20dB Bandwidth | 21 |
| 7.4.1. Test Limit | 21 |
| 7.4.2. Test Procedure Used | 21 |

| | | |
|-----------|---|-----------|
| 7.4.3. | Test Setup..... | 21 |
| 7.4.4. | Test Result..... | 22 |
| 7.5. | Frequency Tolerance..... | 23 |
| 7.5.1. | Test Limit | 23 |
| 7.5.2. | Test Procedure Used | 23 |
| 7.5.3. | Test Setup..... | 23 |
| 7.5.4. | Test Result..... | 24 |
| 7.6. | AC Conducted Emissions Measurement..... | 25 |
| 7.6.1. | Test Limit | 25 |
| 7.6.2. | Test Setup..... | 25 |
| 7.6.3. | Test Result..... | 26 |
| 8. | CONCLUSION..... | 28 |

§2.1033 General Information

| | |
|----------------------------------|---|
| Applicant: | Honeywell International Inc Honeywell Safety and Productivity Solutions |
| Applicant Address: | 9680 Old Bailes Road, Fort Mill, SC 29707 United States |
| Manufacturer: | Honeywell International Inc Honeywell Safety and Productivity Solutions |
| Manufacturer Address: | 9680 Old Bailes Road, Fort Mill, SC 29707 United States |
| Test Site: | MRT Technology (Suzhou) Co., Ltd |
| Test Site Address: | D8 Building, No.2 Tian'edang Rd., Wuzhong Economic Development Zone, Suzhou, China |
| MRT FCC Registration No.: | 893164 |
| MRT IC Registration No.: | 11384A-1 |
| Test Device Serial No.: | N/A <input type="checkbox"/> Production <input checked="" type="checkbox"/> Pre-Production <input type="checkbox"/> Engineering |

Test Facility / Accreditations

Measurements were performed at MRT Laboratory located in Tian'edang Rd., Suzhou, China.

- MRT facility is a FCC registered (MRT Reg. No. 893164) test facility with the site description report on file and has met all the requirements specified in Section 2.948 of the FCC Rules.
- MRT facility is an IC registered (MRT Reg. No. 11384A-1) test laboratory with the site description on file at Industry Canada.
- MRT facility is a VCCI registered (R-20025, G-20034, C-20020, T-20020) test laboratory with the site description on file at VCCI Council.
- MRT Lab is accredited to ISO 17025 by the American Association for Laboratory Accreditation (A2LA) under the American Association for Laboratory Accreditation Program (A2LA Cert. No. 3628.01) in EMC, Telecommunications and Radio testing for FCC, Industry Canada, EU and TELEC Rules.



1. INTRODUCTION

1.1. Scope

Measurement and determination of electromagnetic emissions (EMC) of radio frequency devices including intentional and/or unintentional radiators for compliance with the technical rules and regulations of the Federal Communications Commission and the Industry Canada Certification and Engineering Bureau.

1.2. MRT Test Location

The map below shows the location of the MRT LABORATORY, its proximity to the Taihu Lake. These measurement tests were conducted at the MRT Technology (Suzhou) Co., Ltd. Facility located at D8 Building, No.2 Tian'edang Rd., Wuzhong Economic Development Zone, Suzhou, China. The detailed description of the measurement facility was found to be in compliance with the requirements of § 2.948 according to ANSI C63.4-2009 on September 30, 2013.



2. PRODUCT INFORMATION

2.1. Equipment Description

| | |
|----------------------|--|
| Product Name: | DOLPHIN CT40 |
| Model No.: | CT40-L0N |
| Brand Name: | Honeywell |
| Hardware Version: | 1.0 |
| Software Version: | OS.01.008 |
| Wi-Fi Specification: | 802.11a/b/g/n/ac |
| Bluetooth Version: | v5.0 dual mode |
| NFC: | 13.56MHz |
| Accessories | |
| USB Adapter: | Model No.: ADS-12B-06 05010E Input Power: 100 - 240V ~ 50/60Hz, Max. 0.3A Output Power: 5VDC 2.0A |
| Snap-on Adapter: | Model No.: CT40-SN |
| Battery: | Model No.: CT50-BTSC Capacitance: 15.5Wh, 4090mAh Rated Voltage: 3.8V Limit Charge Voltage: 4.36V |

2.2. Test Mode

| |
|-------------------------|
| Test Mode |
| Mode 1: Transmit by NFC |

2.3. Device Capabilities

This device contains the following capabilities:

2.4GHz WLAN (DTS), 5GHz WLAN (UNII) and Bluetooth (v5.0 dual mode), NFC

2.4. Test Configuration

The **DOLPHIN CT40 FCC ID: HD5-CT40L0N** was set to continuous transmission. This was performance using manufacturer software loaded on the terminal to allow for continuous transmission. This device was tested in accordance with the guidance of ANSI C63.10-2013. ANSI C63.4-2009 was used to reference the appropriate EUT setup for radiated spurious emissions testing and AC line conducted testing.

2.5. EMI Suppression Device(s)/Modifications

No EMI suppression device(s) were added and/or no modifications were made during testing.

2.6. Labeling Requirements

Per 2.1074 & 15.19; Docket 95-19

The label shall be permanently affixed at a conspicuous location on the device; instruction manual or pamphlet supplied to the user and be readily visible to the purchaser at the time of purchase.

However, when the device is so small wherein placement of the label with specified statement is not practical, only the FCC ID must be displayed on the device per Section 15.19(a)(5). Please see attachment for FCC ID label and label location.

RSP-100 Issue 11 Section 3

The manufacturer, importer or distributor shall meet the labelling requirements set out in this section for every unit:

- (i) prior to marketing in Canada, for products manufactured in Canada
- (ii) prior to importation into Canada, for imported products

For information regarding the e-labelling option, see Notice 2014-DRS1003. The label for the certified product represents the manufacturer's or importer's compliance with Innovation, Science and Economic Development Canada's (ISED) regulatory requirements.

Please see attachment for IC label and label location.

3. DESCRIPTION OF TEST

3.1. Evaluation Procedure

The measurement procedures described in the American National Standard for Testing Unlicensed Wireless Devices (ANSI C63.10-2013) was used in the measurement of the **DOLPHIN CT40 FCC ID: HD5-CT40L0N**.

Deviation from measurement procedure.....None

3.2. AC Line Conducted Emissions

The line-conducted facility is located inside an 8'x4'x4' shielded enclosure. A 1m x 2m wooden table 80cm high is placed 40cm away from the vertical wall and 80cm away from the sidewall of the shielded room. Two 10kHz-30MHz, 50Ω/50uH Line-Impedance Stabilization Networks (LISNs) are bonded to the shielded room floor. Power to the LISNs is filtered by external high-current high-insertion loss power line filters. These filters attenuate ambient signal noise from entering the measurement lines. These filters are also bonded to the shielded enclosure.

The EUT is powered from one LISN and the support equipment is powered from the second LISN. All interconnecting cables more than 1 meter were shortened to a 1 meter length by non-inductive bundling (serpentine fashion) and draped over the back edge of the test table. All cables were at least 40cm above the horizontal reference ground-plane. Power cables for support equipment were routed down to the second LISN while ensuring that that cables were not draped over the second LISN.

Sufficient time for the EUT, support equipment, and test equipment was allowed in order for them to warm up to their normal operating condition. The RF output of the LISN was connected to the receiver and exploratory measurements were made to determine the frequencies producing the maximum emission from the EUT. The receiver was scanned from 150kHz to 30MHz. The detector function was set to peak mode for exploratory measurements while the bandwidth of the analyzer was set to 9kHz. The EUT, support equipment, and interconnecting cables were arranged and manipulated to maximize each emission. Each emission was also maximized by varying: power lines, the mode of operation or data exchange speed, or support equipment whichever determined the worst-case emission. Once the worst case emissions have been identified, the one EUT cable configuration/arrangement and mode of operation that produced these emissions are used for final measurements on the same test site. The analyzer is set to CISPR quasi-peak and average detectors with a 9kHz resolution bandwidth for final measurements.

An extension cord was used to connect to a single LISN which powered by EUT. The extension cord was calibrated with LISN, the impedance and insertion loss are compliance with the requirements as stated in ANSI C63.10-2013 at Clause 4.3.

3.3. Radiated Emissions

The radiated test facilities consisted of an indoor 3 meter semi-anechoic chamber used for final measurements and exploratory measurements, when necessary. The measurement area is contained within the semi-anechoic chamber which is shielded from any ambient interference. For measurements above 1GHz absorbers are arranged on the floor between the turn table and the antenna mast in such a way so as to maximize the reduction of reflections. For measurements below 1GHz, the absorbers are removed. A MF Model 210SS turntable is used for radiated measurement. It is a continuously rotatable, remote controlled, metallic turntable and 2 meters (6.56 ft.) in diameter. The turn table is flush with the raised floor of the chamber in order to maintain its function as a ground plane. An 80cm high PVC support structure is placed on top of the turntable.

For all measurements, the spectrum was scanned through all EUT azimuths and from 1 to 4 meter receive antenna height using a broadband antenna from 30MHz up to the upper frequency shown in 15.33(b)(1) depending on the highest frequency generated or used in the device or on which the device operates or tunes. For frequencies above 1GHz, linearly polarized double ridge horn antennas were used. For frequencies below 30MHz, a calibrated loop antenna was used. When exploratory measurements were necessary, they were performed at 1 meter test distance inside the semi-anechoic chamber using broadband antennas, broadband amplifiers, and spectrum analyzers to determine the frequencies and modes producing the maximum emissions. Sufficient time for the EUT, support equipment, and test equipment was allowed in order for them to warm up to their normal operating condition. The test set-up was placed on top of the 0.8 meter high, 1 x 1.5 meter table. The EUT, support equipment, and interconnecting cables were arranged and manipulated to maximize each emission. Appropriate precaution was taken to ensure that all emissions from the EUT were maximized and investigated. The system configuration, clock speed, mode of operation or video resolution, if applicable, turntable azimuth, and receive antenna height was noted for each frequency found.

Final measurements were made in the semi-anechoic chamber using calibrated, linearly polarized broadband and horn antennas. The test setup was configured to the setup that produced the worst case emissions. The spectrum analyzer was set to investigate all frequencies required for testing to compare the highest radiated disturbances with respect to the specified limits. The turntable containing the EUT was rotated through 360 degrees and the height of the receive antenna was varied 1 to 4 meters and stopped at the azimuth and height producing the maximum emission. Each emission was maximized by changing the orientation of the EUT through three orthogonal planes and changing the polarity of the receive antenna, whichever produced the worst-case emissions. According to 3dB Beam-Width of horn antenna, the horn antenna should be always directed to the EUT when rising height.

4. ANTENNA REQUIREMENTS

Excerpt from §15.203 of the FCC Rules/Regulations:

“An intentional radiator antenna shall be designed to ensure that no antenna other than that furnished by the responsible party can be used with the device. The use of a permanently attached antenna or of an antenna that uses a unique coupling to the intentional radiator shall be considered sufficient to comply with the provisions of this section.”

- The antenna of the DOLPHIN CT40 is **permanently attached**.
- There are no provisions for connection to an external antenna.

Conclusion:

The **DOLPHIN CT40** unit complies with the requirement of §15.203.

5. TEST EQUIPMENT CALIBRATION DATA

Conducted Emission - SR2

| Instrument | Manufacturer | Type No. | Asset No. | Cali. Interval | Cali. Due Date |
|----------------------------|--------------|-------------|-------------|----------------|----------------|
| EMI Test Receiver | R&S | ESR7 | MRTSUE06001 | 1 year | 2018/08/18 |
| Two-Line V-Network | R&S | ENV 216 | MRTSUE06002 | 1 year | 2018/06/21 |
| Two-Line V-Network | R&S | ENV 216 | MRTSUE06003 | 1 year | 2018/06/21 |
| Thermohygrometer | Testo | 608-H1 | MRTSUE06404 | 1 year | 2018/08/14 |
| Shielding Anechoic Chamber | Mikebang | Chamber-SR2 | MRTSUE06214 | N/A | N/A |

Radiated Emissions - AC1

| Instrument | Manufacturer | Type No. | Asset No. | Cali. Interval | Cali. Due Date |
|----------------------------|--------------|-------------|-------------|----------------|----------------|
| MXE EMI Receiver | Agilent | N9038A | MRTSUE06125 | 1 year | 2018/08/18 |
| EMI Test Receiver | R&S | ESR7 | MRTSUE06001 | 1 year | 2018/08/18 |
| Microwave System Amplifier | Agilent | 83017A | MRTSUE06076 | 1 year | 2018/11/17 |
| Loop Antenna | Schwarzbeck | FMZB 1519 | MRTSUE06025 | 1 year | 2018/11/20 |
| Bilog Period Antenna | Schwarzbeck | VULB 9168 | MRTSUE06172 | 1 year | 2018/11/18 |
| Broad Band Horn Antenna | Schwarzbeck | BBHA9120D | MRTSUE06023 | 1 year | 2018/10/21 |
| Broad Band Horn Antenna | Schwarzbeck | BBHA 9170 | MRTSUE06024 | 1 year | 2018/12/14 |
| Thermohygrometer | Testo | 608-H1 | MRTSUE06403 | 1 year | 2018/08/14 |
| Anechoic Chamber | TDK | Chamber-AC1 | MRTSUE06212 | 1 year | 2018/05/10 |
| | | | | 1 year | 2019/05/10 |

| Software | Version | Function |
|--------------|---------|-------------------|
| EMI Software | V3 | EMI Test Software |

6. MEASUREMENT UNCERTAINTY

Where relevant, the following test uncertainty levels have been estimated for tests performed on the EUT as specified in CISPR 16-4-2. This uncertainty represents an expanded uncertainty expressed at approximately the 95% confidence level using a coverage factor of $k = 2$.

| |
|---|
| AC Conducted Emission Measurement - SR2 |
| Measuring Uncertainty for a Level of Confidence of 95% ($U=2Uc(y)$): 150kHz~30MHz: 3.46dB |
| Radiated Emission Measurement - AC1 |
| Measuring Uncertainty for a Level of Confidence of 95% ($U=2Uc(y)$): 9kHz ~ 1GHz: 4.18dB 1GHz ~ 25GHz: 4.76dB |

7. TEST RESULT

7.1. Summary

Product Name: DOLPHIN CT40

Test Mode: NFC Transmit

| FCC Part Section(s) | RSS Section(s) | Test Description | Test Limit | Test Condition | Test Result | Reference |
|------------------------|------------------|---|---|-------------------|-------------|-------------|
| 15.225(a), (b), (c) | RSS-210 [B.6] | In-Band Emission | 15,848uV/m @ 30m 13.553 ~ 13.567 MHz 334uV/m @ 30m 13.410 ~ 13.553 MHz 13.567 ~ 13.710 MHz 106uV/m @ 30m 13.110 ~ 13.410 MHz 13.710 ~ 14.010 MHz | Radiated | Pass | Section 7.2 |
| 15.225(d) | RSS-210 [B.6] | Out-Band Emission | Emissions outside of the specified band (13.110~14.010 MHz) must meet the radiated limits detailed in 15.209 | | Pass | Section 7.3 |
| 2.1049 | N/A | 20dB Bandwidth | N/A | | Pass | Section 7.4 |
| 15.225(e) | RSS-210 [B.6] | Frequency Stability Tolerance | ±0.01% of operating frequency | | Pass | Section 7.5 |
| 15.207 | RSS-Gen [8.8] | AC Conducted Emissions 150kHz - 30MHz | < FCC 15.207 limits | Line Conducted | Pass | Section 7.6 |

Notes:

- 1) All modes of operation and data rates were investigated. For radiated emission test, every axis (X, Y, Z) was also verified. The test results shown in the following sections represent the worst case emissions.
- 2) The analyzer plots shown in this section were all taken with a correction table loaded into the analyzer. The correction table was used to account for the losses of the cables and attenuators used as part of the system to connect the EUT to the analyzer at all frequencies of interest.
- 3) All antenna port conducted emissions testing was performed on a test bench with the antenna port of the EUT connected to the spectrum analyzer through calibrated cables and attenuators.

7.2. In-band Emission

7.2.1. Test Limit

| FCC Part 15 Subpart C Paragraph 15.225 | | |
|--|--------------|--------------|
| Frequency (MHz) | Distance (m) | Level (uV/m) |
| 13.553 ~13.567 | 30 | 15,848 |
| 13.410 ~13.553 13.567 ~13.710 | 30 | 334 |
| 13.110 ~13.410 13.710 ~14.010 | 30 | 106 |

Note 1: The lower limit shall apply at the transition frequency.

Note 2: Distance refers to the distance in meters between the measuring instrument antenna and the closed point of any part of the device or system.

Note 3: E field strength (dBuV/m) = 20 log E field strength (uV/m)

7.2.2. Test Procedure Used

The EUT was setup according to ANSI C63.4, 2009 and tested according to ANSI C63.10: 2009 for compliance to FCC 47CFR 15.247 requirements.

The EUT is placed on a turn table which is 0.8 meter above ground. The turn table is rotated 360 degrees to determine the position of the maximum emission level. The EUT was positioned such that the distance from antenna to the EUT was 3 meters.

The antenna is scanned from 1 meter to 4 meters to find out the maximum emission level. This is repeated for both horizontal and vertical polarization of the antenna. In order to find the maximum emission, all of the interface cables were manipulated according to ANSI C63.4:2009 on radiated measurement.

The EUT should be operate in transmission mode.

7.2.3. Test Setup

9kHz ~ 30MHz Test Setup:

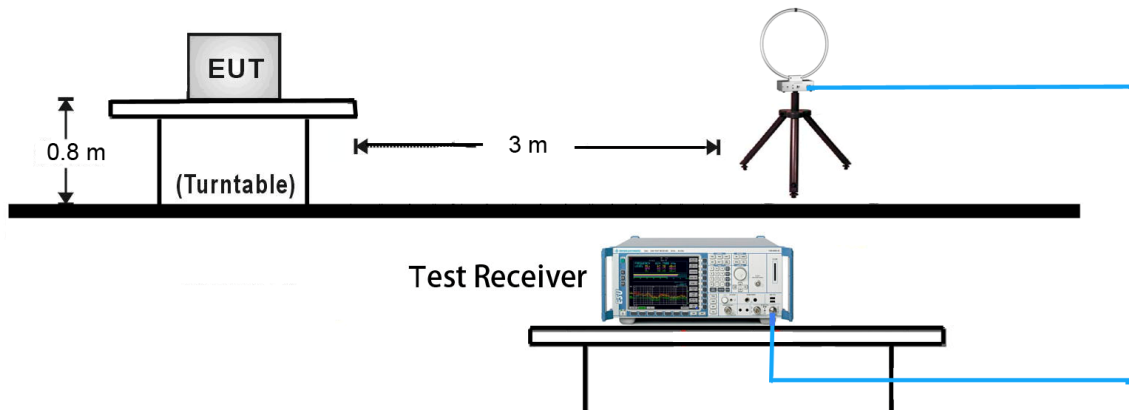

30MHz ~ 1GHz Test Setup:

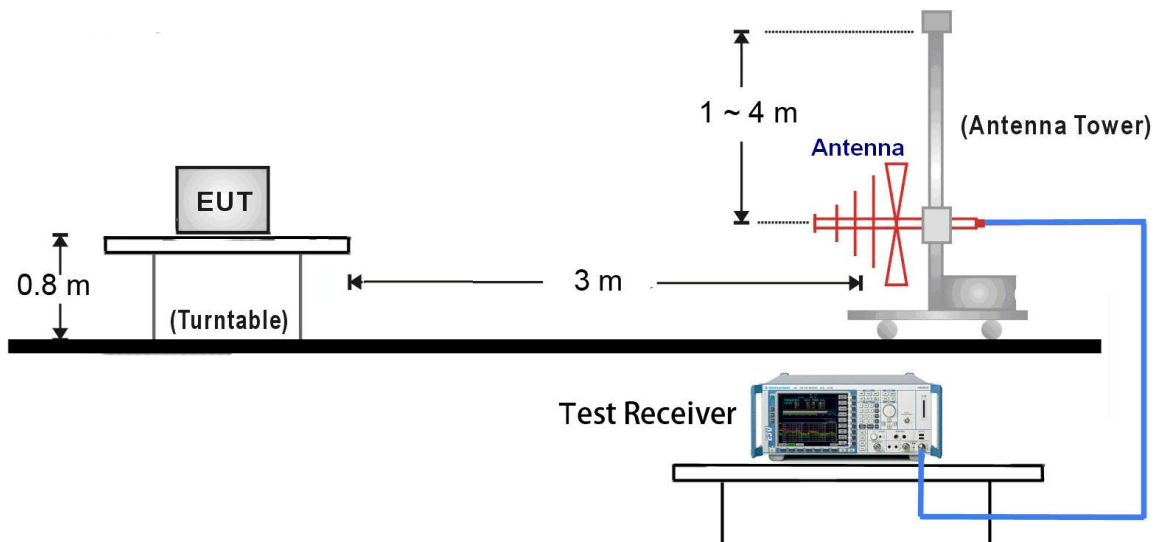

7.2.4. Test Result

| | | | |
|---------------|------------|-------------------|------|
| Test Engineer | Snake Ni | Temperature | 25°C |
| Test Time | 2018/04/21 | Relative Humidity | 56% |
| Test Mode | Mode1 | Test Site | AC1 |

| Frequency | Reading Level(dBuV/m) | Factor | Measure Level(dBuV/m) | Limit(3m) [dBuV/m] | Margin [dB] |
|-----------|-----------------------|--------|-----------------------|--------------------|-------------|
| Face On | | | | | |
| 13.34 | 9.01 | 19.85 | 28.86 | 80.51 | -51.65 |
| 13.51 | 10.81 | 19.87 | 30.68 | 90.47 | -59.79 |
| 13.56 | 36.63 | 19.87 | 56.50 | 123.99 | -67.49 |
| 13.61 | 12.02 | 19.86 | 31.88 | 90.47 | -58.59 |
| 13.78 | 13.22 | 19.88 | 33.10 | 80.51 | -47.41 |
| Face Off | | | | | |
| 13.36 | 7.64 | 19.85 | 27.49 | 80.51 | -53.02 |
| 13.52 | 10.65 | 19.86 | 30.51 | 90.47 | -59.96 |
| 13.56 | 30.64 | 19.87 | 50.51 | 123.99 | -73.48 |
| 13.57 | 30.61 | 19.87 | 50.48 | 90.47 | -39.99 |
| 13.72 | 8.17 | 19.87 | 28.04 | 80.51 | -52.47 |

Note1: All measurements were performed using a loop antenna. The antenna was positioned in two orthogonal (face on and face off) and the position with the highest emission level was recorded.

Note2: Measurements were tested at 3m and the data was extrapolated to the specified measurement distance of 30m using the square of an inverse linear extrapolation factor (40 dB/decade) as specified in §15.31(f)(2).

Extrapolation Factor = $40 \cdot \text{LOG}(30/3) = 40 \text{ dB}$

Note3: All measurements were recorded using a EMI test receiver employing a peak detector.

7.3. Out-band Emission

7.3.1. Test Limit

| FCC Part 15 Subpart C Paragraph 15.209 | | |
|--|--------------|--------------|
| Frequency (MHz) | Distance (m) | Level (uV/m) |
| 0.009 - 0.490 | 300 | 2400/F (kHz) |
| 0.490 - 1.705 | 30 | 2400/F (kHz) |
| 1.705 - 30 | 30 | 30 |
| 30 - 88 | 3 | 100 |
| 88 - 216 | 3 | 150 |
| 216 - 960 | 3 | 200 |
| Above 960 | 3 | 500 |

Note 1: The lower limit shall apply at the transition frequency.

Note 2: Distance refers to the distance in meters between the measuring instrument antenna and the closed point of any part of the device or system.

Note 3: E field strength (dBuV/m) = 20 log E field strength (uV/m)

7.3.2. Test Procedure Used

The EUT was tested from 9kHz up to the 1GHz excluding the band 13.110-14.010 MHz. All measurements were recorded with a spectrum analyzer employing an average detector for emissions below 30MHz. Above 30MHz a Quasi-peak detector was used. All out-of-band emissions must not exceed the limits shown as stated per Section 15.209. A loop antenna was used for searching for emissions below 30MHz.

7.3.3. Test Setup

9kHz ~ 30MHz Test Setup:

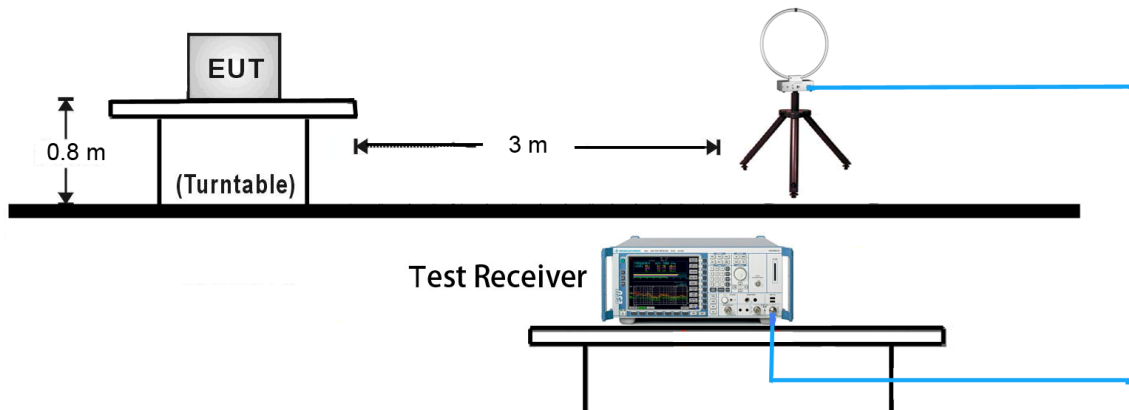

30MHz ~ 1GHz Test Setup:

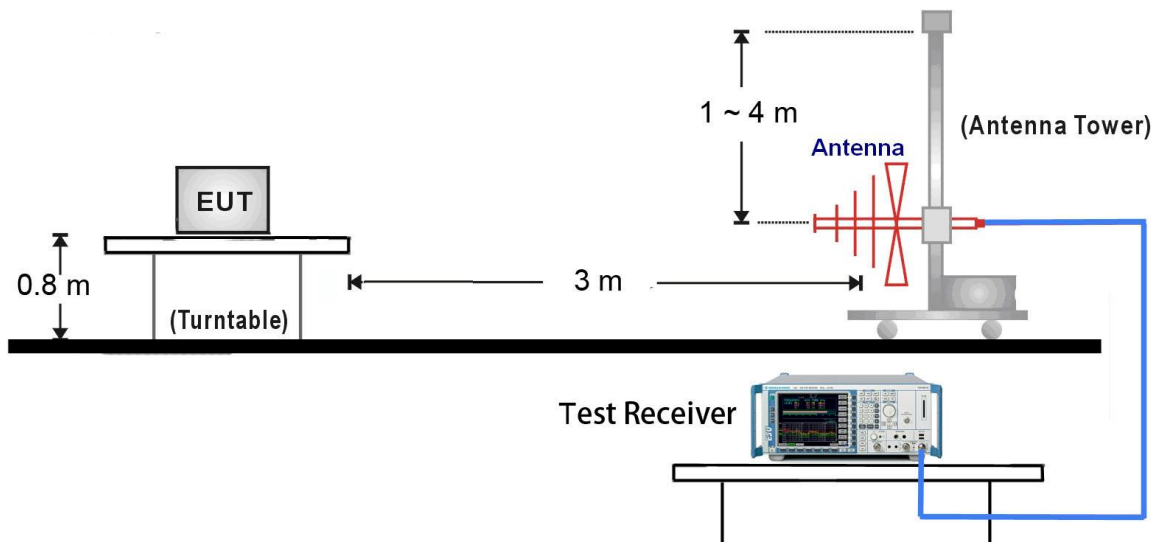

7.3.4. Test Result

| | | | |
|---------------|------------|-------------------|------|
| Test Engineer | Snake Ni | Temperature | 25°C |
| Test Time | 2018/04/21 | Relative Humidity | 56% |
| Test Mode | Mode1 | Test Site | AC1 |

| Out-of-Band Emission Below 30MHz | | | | | | |
|----------------------------------|------------------------|-------------|------------------------|----------------|-------------|----------|
| Frequency (MHz) | Reading Level (dBuV/m) | Factor (dB) | Measure Level (dBuV/m) | Limit (dBuV/m) | Margin (dB) | Detector |
| Face On | | | | | | |
| 27.12 | -1.5 | 19.51 | 18.01 | 69.54 | -51.53 | QP |
| Face Off | | | | | | |
| 27.12 | -0.7 | 19.51 | 18.81 | 69.54 | -50.73 | QP |

| Out-of-Band Emission Above 30MHz | | | | | | | |
|----------------------------------|-----------------|------------------------|-------------|------------------------|----------------|-------------|----------|
| Antenna | Frequency (MHz) | Reading Level (dBuV/m) | Factor (dB) | Measure Level (dBuV/m) | Limit (dBuV/m) | Margin (dB) | Detector |
| H | 44.55 | 4.10 | 14.33 | 18.43 | 40.00 | -21.57 | QP |
| H | 90.63 | 8.82 | 10.37 | 19.19 | 43.50 | -24.31 | QP |
| H | 107.60 | 7.25 | 11.85 | 19.10 | 43.50 | -24.40 | QP |
| H | 165.80 | 2.93 | 14.77 | 17.70 | 43.50 | -25.80 | QP |
| H | 203.15 | 6.42 | 11.26 | 17.68 | 43.50 | -25.82 | QP |
| H | 396.66 | 3.15 | 16.52 | 19.67 | 46.00 | -26.33 | QP |
| V | 43.58 | 15.50 | 14.38 | 29.88 | 40.00 | -10.12 | QP |
| V | 58.62 | 9.16 | 13.57 | 22.73 | 40.00 | -17.27 | QP |
| V | 68.32 | 9.74 | 11.90 | 21.64 | 40.00 | -18.36 | QP |
| V | 87.72 | 11.30 | 10.27 | 21.57 | 40.00 | -18.43 | QP |
| V | 107.60 | 10.60 | 11.85 | 22.45 | 43.50 | -21.05 | QP |
| V | 176.96 | 8.49 | 13.36 | 21.85 | 43.50 | -21.65 | QP |

Note1: All measurements were performed using a loop antenna. The antenna was positioned in two orthogonal (face on and face off) and the position with the highest emission level was recorded.

Note2: Measurements were tested at 3m and the data was extrapolated to the specified measurement distance of 30m using the square of an inverse linear extrapolation factor (40 dB/decade) as specified in §15.31(f)(2).

Extrapolation Factor = $40 \cdot \text{LOG}(30/3) = 40 \text{ dB}$

Note3: All measurements were recorded using a EMI test receiver employing a peak detector.

7.4. 20dB Bandwidth

7.4.1. Test Limit

N/A

7.4.2. Test Procedure Used

The 20dB bandwidth is measured with a spectrum analyzer connected via a receive antenna placed near the EUT while the EUT is operating in transmission mode.

7.4.3. Test Setup

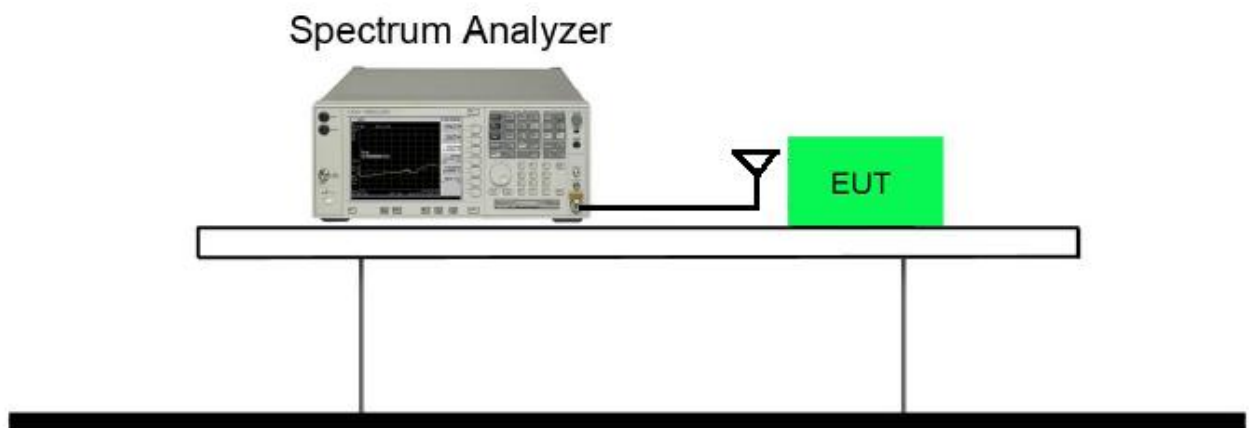

7.4.4. Test Result

| | | | |
|---------------|------------|-------------------|------|
| Test Engineer | Snake Ni | Temperature | 25°C |
| Test Time | 2018/06/26 | Relative Humidity | 56% |
| Test Mode | Mode1 | Test Site | AC1 |

| Frequency (MHz) | 20dB Occupied Bandwidth (kHz) | 99% Occupied Bandwidth (kHz) |
|-----------------|-------------------------------|------------------------------|
| 13.56 | 13.09 | 92.75 |

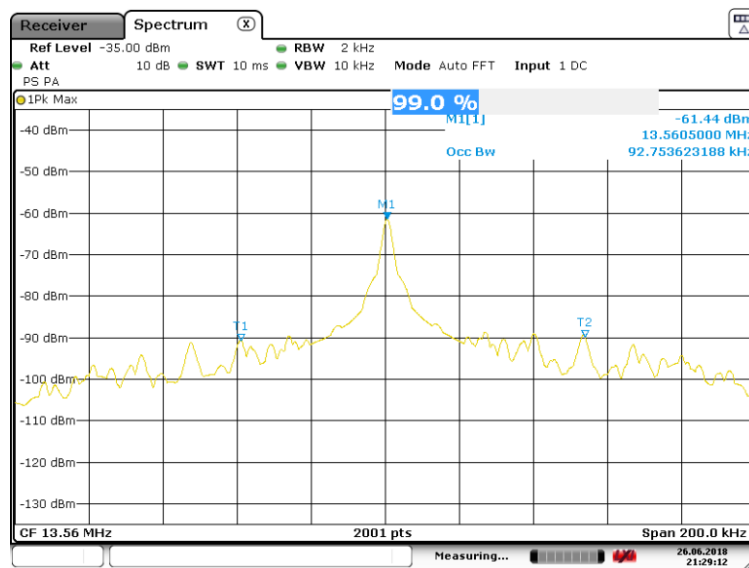

Date: 26 JUN.2018 21:29:12



Date: 26 JUN.2018 21:30:51

7.5. Frequency Tolerance

7.5.1. Test Limit

The frequency tolerance of the carrier signal shall be maintained within $\pm 0.01\%$ of the operating frequency.

7.5.2. Test Procedure Used

The equipment under test was connected to an external AC or DC power supply and input rated voltage. RF output was connected to a frequency counter or spectrum analyzer via feed through attenuators. The EUT was placed inside the temperature chamber. Set the spectrum analyzer RBW low enough to obtain the desired frequency resolution and measure EUT 20°C operating frequency as reference frequency. Turn EUT off and set the chamber temperature to highest. After the temperature stabilized for approximately 30 minutes recorded the frequency. Repeat step measure with 10°C decreased per stage until the lowest temperature reached.

7.5.3. Test Setup

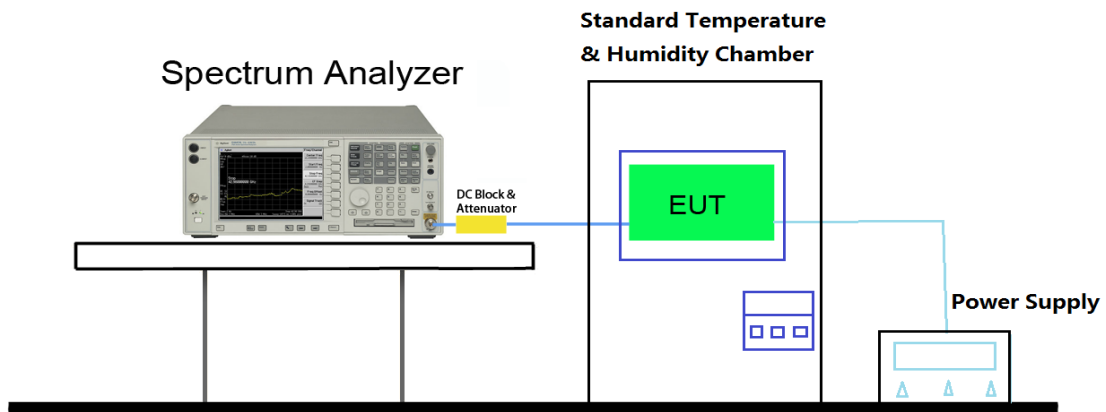

7.5.4. Test Result

| | | | |
|---------------|------------|-------------------|------|
| Test Engineer | Snake Ni | Temperature | 25°C |
| Test Time | 2018/04/21 | Relative Humidity | 56% |
| Test Mode | Mode1 | Test Site | AC1 |

| Operating Frequency: 13.56MHz | | | | | |
|-------------------------------------|---------------|-----------|------------|-----------------|---------------|
| Reference Voltage: 3.8Vdc | | | | | |
| Deviation Limit: +/- 0.01% = 1356Hz | | | | | |
| Voltage (%) | Power Battery | TEMP (°C) | FREQ. (Hz) | FREQ. Dev. (Hz) | Deviation (%) |
| 100% | 3.80 | +20(Ref) | 13,560,452 | 452 | 0.003333 |
| 100% | | -20 | 13,560,646 | 646 | 0.004764 |
| 100% | | -10 | 13,560,234 | 234 | 0.001726 |
| 100% | | 0 | 13,559,194 | 194 | 0.001431 |
| 100% | | +10 | 13,560,673 | 673 | 0.004963 |
| 100% | | +20 | 13,559,241 | 241 | 0.001777 |
| 100% | | +30 | 13,560,188 | 188 | 0.001386 |
| 100% | | +40 | 13,560,325 | 325 | 0.002397 |
| 100% | | +50 | 13,560,357 | 357 | 0.002633 |
| Battery End Point | | 3.50 | +20 | 13,560,694 | 694 |
| 115% | 4.30 | +20 | 13,560,942 | 942 | -1356 ~ +1356 |

7.6. AC Conducted Emissions Measurement

7.6.1. Test Limit

| FCC Part 15 Subpart C Paragraph 15.207 Limits | | |
|---|-----------|-----------|
| Frequency (MHz) | QP (dBuV) | AV (dBuV) |
| 0.15 - 0.50 | 66 - 56 | 56 - 46 |
| 0.50 - 5.0 | 56 | 46 |
| 5.0 - 30 | 60 | 50 |

Note 1: The lower limit shall apply at the transition frequencies.

Note 2: The limit decreases linearly with the logarithm of the frequency in the range 0.15MHz to 0.5MHz.

7.6.2. Test Setup

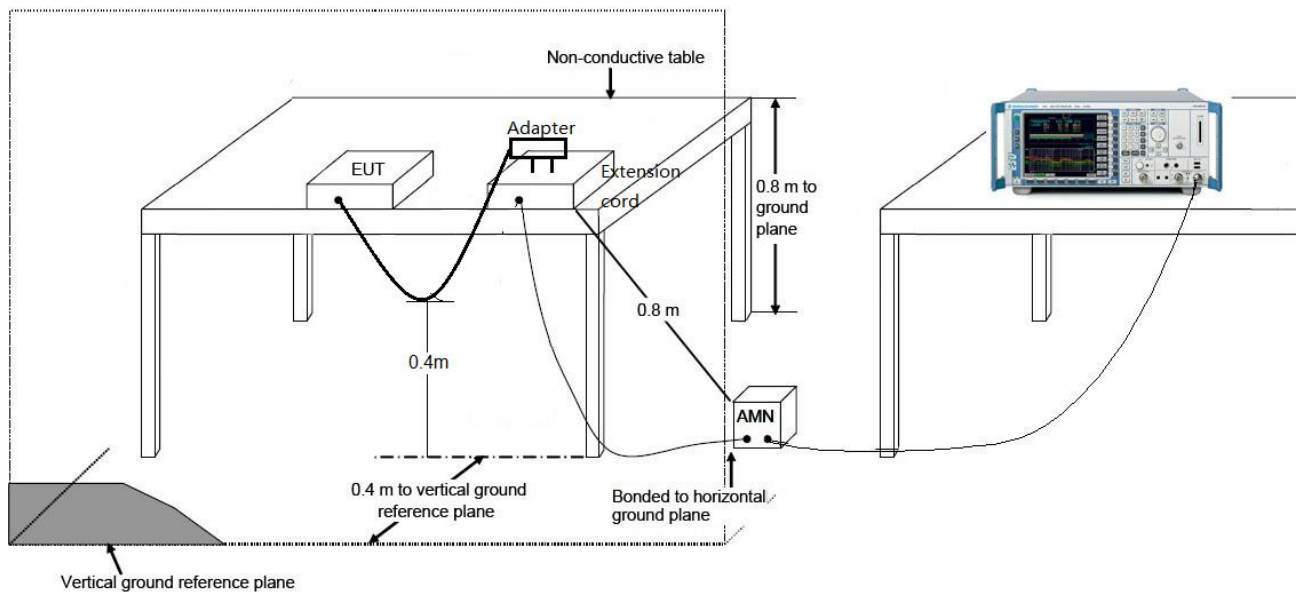

7.6.3. Test Result

| | |
|-----------------------------------|--------------------------|
| Site: SR2 | Time: 2018/04/27 - 13:54 |
| Limit: FCC_Part15.207_CE_AC Power | Engineer: Bacon Dong |
| Probe: ENV216_101683_Filter On | Polarity: Line |
| EUT: DOLPHIN CT40 | Power: AC 120V/60Hz |
| Test Mode: Mode 1 | |

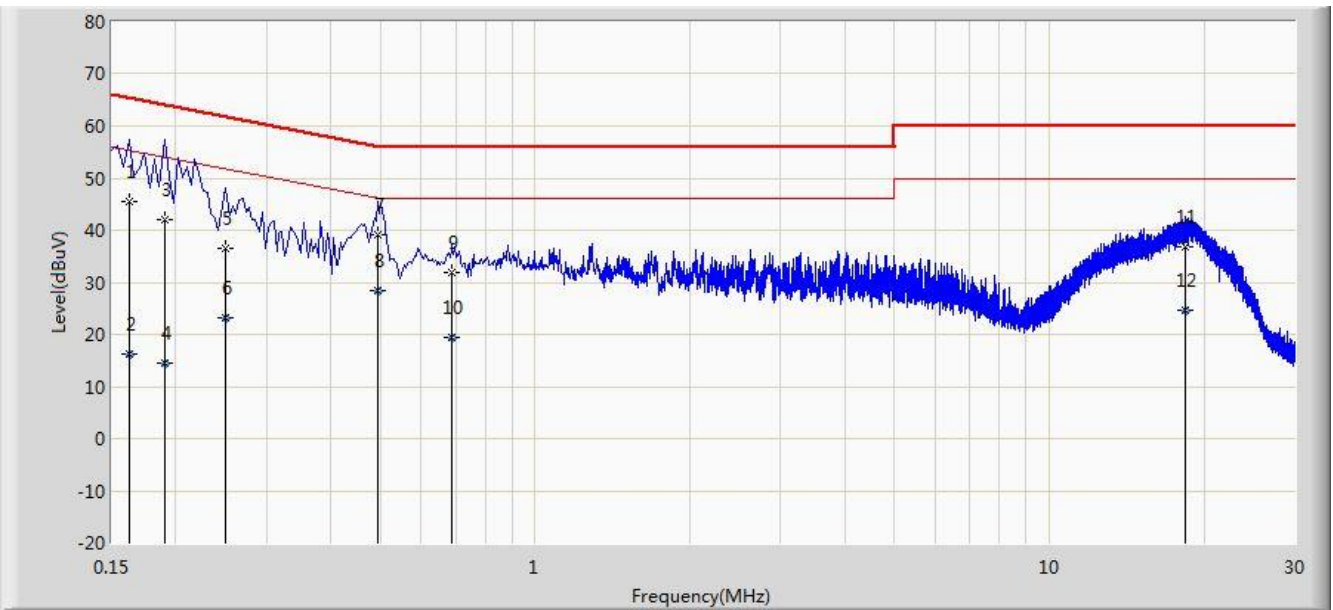

| No | Flag | Mark | Frequency (MHz) | Measure Level (dBuV) | Reading Level (dBuV) | Over Limit (dB) | Limit (dBuV) | Factor (dB) | Type |
|----|------|------|-----------------|----------------------|----------------------|-----------------|--------------|-------------|------|
| 1 | | | 0.162 | 45.371 | 35.274 | -19.990 | 65.361 | 10.097 | QP |
| 2 | | | 0.162 | 16.353 | 6.256 | -39.008 | 55.361 | 10.097 | AV |
| 3 | | | 0.190 | 41.997 | 31.968 | -22.039 | 64.037 | 10.029 | QP |
| 4 | | | 0.190 | 14.533 | 4.504 | -39.504 | 54.037 | 10.029 | AV |
| 5 | | | 0.250 | 36.601 | 26.637 | -25.156 | 61.757 | 9.964 | QP |
| 6 | | | 0.250 | 23.255 | 13.291 | -28.502 | 51.757 | 9.964 | AV |
| 7 | | * | 0.494 | 39.062 | 28.904 | -17.038 | 56.100 | 10.158 | QP |
| 8 | | | 0.494 | 28.383 | 18.226 | -17.717 | 46.100 | 10.158 | AV |
| 9 | | | 0.690 | 31.791 | 21.723 | -24.209 | 56.000 | 10.068 | QP |
| 10 | | | 0.690 | 19.449 | 9.381 | -26.551 | 46.000 | 10.068 | AV |
| 11 | | | 18.342 | 36.799 | 26.697 | -23.201 | 60.000 | 10.102 | QP |
| 12 | | | 18.342 | 24.556 | 14.454 | -25.444 | 50.000 | 10.102 | AV |

Note: Measure Level (dBμV) = Reading Level (dBμV) + Factor (dB)

Factor (dB) = Cable Loss (dB) + LISN Factor (dB).

| | |
|-----------------------------------|--------------------------|
| Site: SR2 | Time: 2018/04/27 - 13:58 |
| Limit: FCC_Part15.207_CE_AC Power | Engineer: Bacon Dong |
| Probe: ENV216_101683_Filter On | Polarity: Neutral |
| EUT: DOLPHIN CT40 | Power: AC 120V/60Hz |
| Test Mode: Mode 1 | |

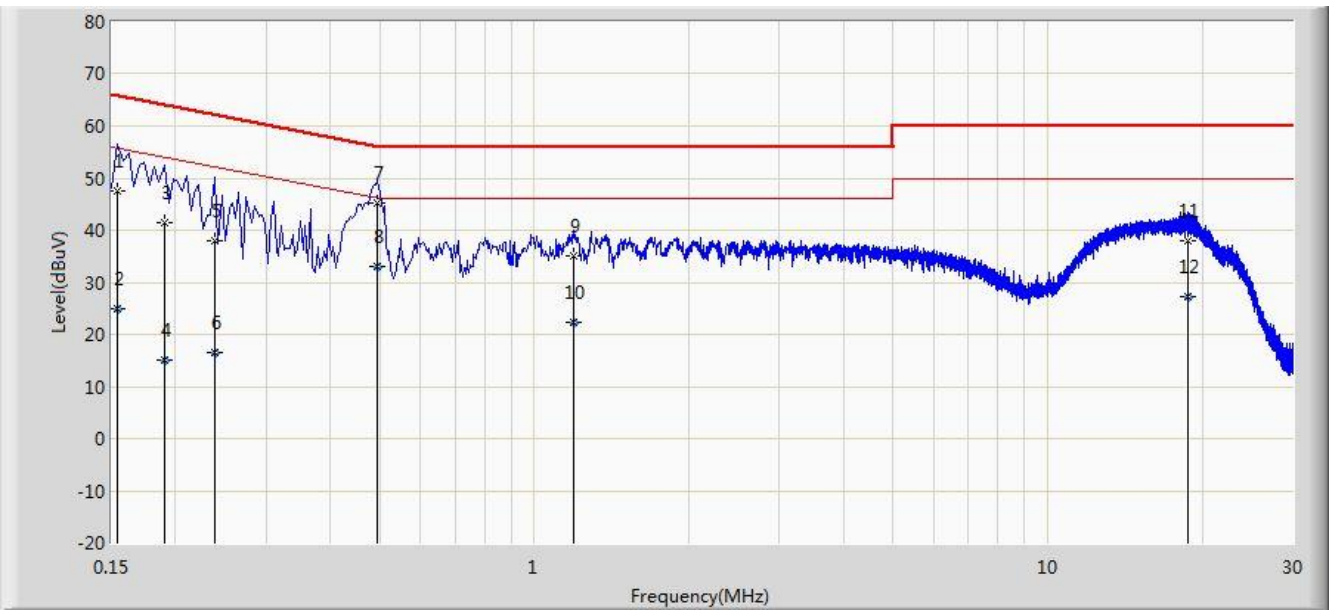

| No | Flag | Mark | Frequency (MHz) | Measure Level (dBuV) | Reading Level (dBuV) | Over Limit (dB) | Limit (dBuV) | Factor (dB) | Type |
|----|------|------|-----------------|----------------------|----------------------|-----------------|--------------|-------------|------|
| 1 | | | 0.154 | 47.443 | 36.728 | -18.338 | 65.781 | 10.716 | QP |
| 2 | | | 0.154 | 24.945 | 14.229 | -30.836 | 55.781 | 10.716 | AV |
| 3 | | | 0.190 | 41.321 | 31.294 | -22.715 | 64.037 | 10.028 | QP |
| 4 | | | 0.190 | 14.955 | 4.927 | -39.081 | 54.037 | 10.028 | AV |
| 5 | | | 0.238 | 38.062 | 28.070 | -24.104 | 62.166 | 9.992 | QP |
| 6 | | | 0.238 | 16.540 | 6.548 | -35.626 | 52.166 | 9.992 | AV |
| 7 | | * | 0.494 | 45.135 | 34.957 | -10.965 | 56.100 | 10.178 | QP |
| 8 | | | 0.494 | 33.041 | 22.862 | -13.060 | 46.100 | 10.178 | AV |
| 9 | | | 1.194 | 34.947 | 25.045 | -21.053 | 56.000 | 9.903 | QP |
| 10 | | | 1.194 | 22.308 | 12.405 | -23.692 | 46.000 | 9.903 | AV |
| 11 | | | 18.706 | 38.016 | 27.875 | -21.984 | 60.000 | 10.141 | QP |
| 12 | | | 18.706 | 27.139 | 16.997 | -22.861 | 50.000 | 10.141 | AV |

Note: Measure Level (dBμV) = Reading Level (dBμV) + Factor (dB)

Factor (dB) = Cable Loss (dB) + LISN Factor (dB).

8. CONCLUSION

The data collected relate only the item(s) tested and show that the **DOLPHIN CT40 FCC ID: HD5-CT40L0N** is in compliance with Part 15C of the FCC Rules and RSS rules.

————— The End —————