

## EN1342-60 Activity Monitoring Detector Installation and Operation Manual

### 1 Overview

The EN1342-60 activity monitoring detector is designed specifically for residential and senior living environments where a notification of daily activity is necessary. It leverages the latest motion detector technology, including white light and pet immunity, to ensure performance accuracy. Selectable fixed sleep intervals of two, four or six hours are used to minimize wireless traffic in large installations. Check-in messages are sent every 60 minutes to provide effective notification of activity even when the device is in the fixed sleep cycle.

#### 1.1 Inovonics Contact Information

 For product and installation videos visit us at [www.inovonics.com/videos](http://www.inovonics.com/videos) or use the QR code below.



If you have any problems with this procedure, contact Inovonics technical support:

- E-mail: [support@inovonics.com](mailto:support@inovonics.com).
- Phone: (800) 782-2709; (303) 939-9336.

### 2 Installation and Startup

#### 2.1 Installation Notes

- These products are designed to be maintained by professional security technicians
- Products are tested for indoor use
- All products should be manually tested weekly

#### 2.2 Mount the Housing and Install the Battery

1. Loosen the captive housing screw.
2. Open the housing.

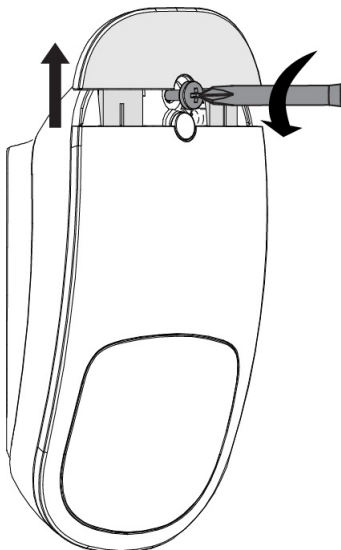

**Figure 1** Open the housing

3. Remove the EN1342-60 from the mounting bracket per Figure 2.

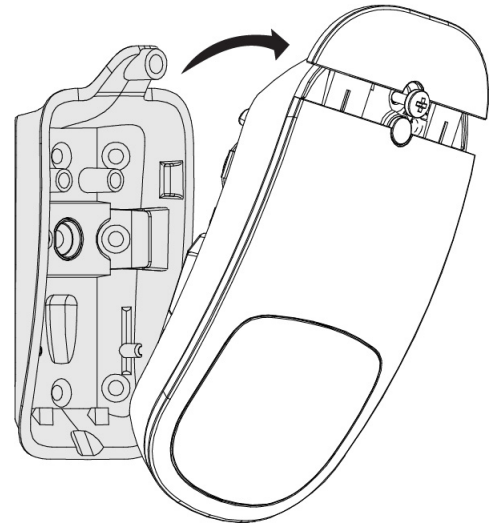
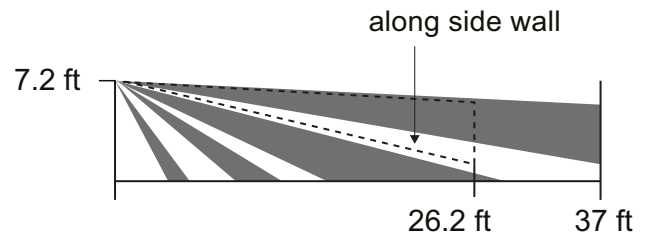

**Figure 2** Remove the EN1342-60 from the mounting bracket

4. Noting the detection coverage in Figure 3, determine mounting location.

- Avoid areas facing direct sunlight, areas where areas that may change temperature rapidly, and areas where there are air ducts or substantial airflows.
- The recommended mounting height is 6.5 feet to 7.5 feet (2.1 to 2.3 m).

#### Side VIEW



#### TOP VIEW

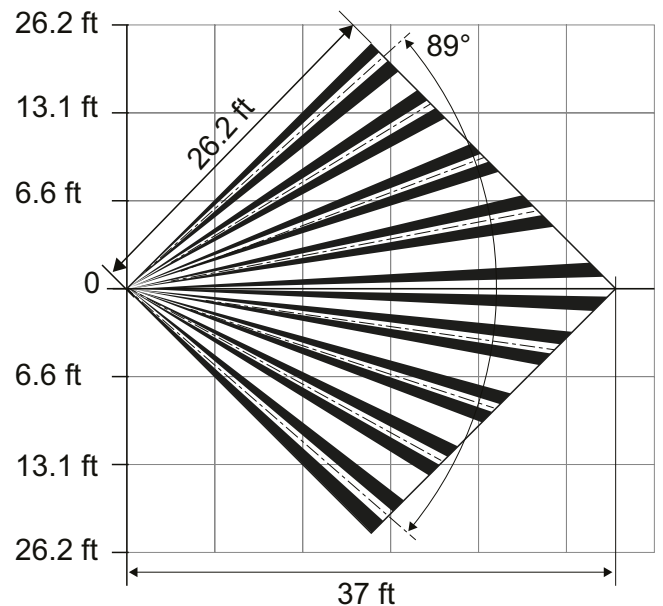

**Figure 3** EN1342-60 detection coverage area



5. Use the included three mounting screws to mount the EN1342-60.
- To mount on the wall, see Figure 4.
  - To mount in a corner, see Figure 5.

**Note:** The black arrows represent recommended mounting screw locations; the gray arrows represent optional mounting screw locations should the recommended locations be unavailable.

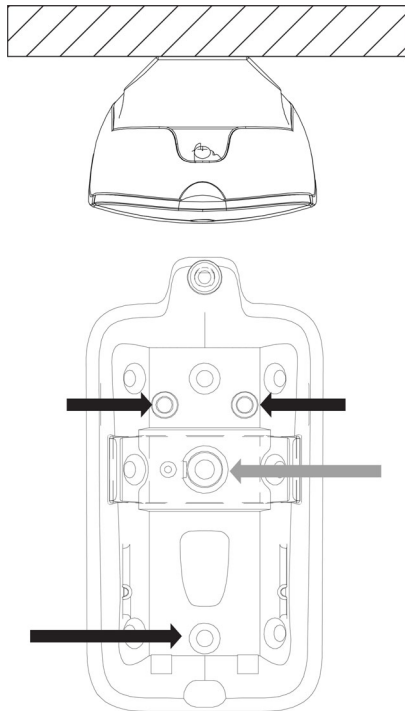

Figure 4 Wallmount configuration

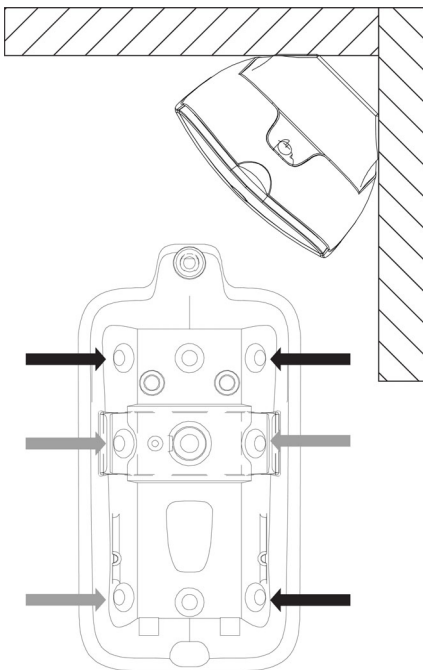

Figure 5 Cornermount configuration

6. Install the battery per Figure 6.

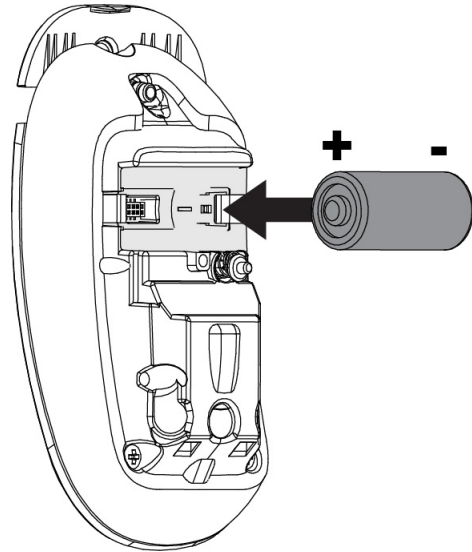

Figure 6 Install the battery

### 2.3 Select Pulse Count

The pulse count options provides control for difficult operating environments. Automatic pulse count is recommended for reliable operation in environments subject to temperature fluctuation that can cause false alarms. The single pulse count mode is more sensitive to minor temperature variations, and should be used in sites where variant heat sources will not cause alarms. Automatic pulse count is the factory default because it allows more reliable operation in environments subject to temperature fluctuation. To select pulse count:

1. Press the tamper button five times within three seconds.

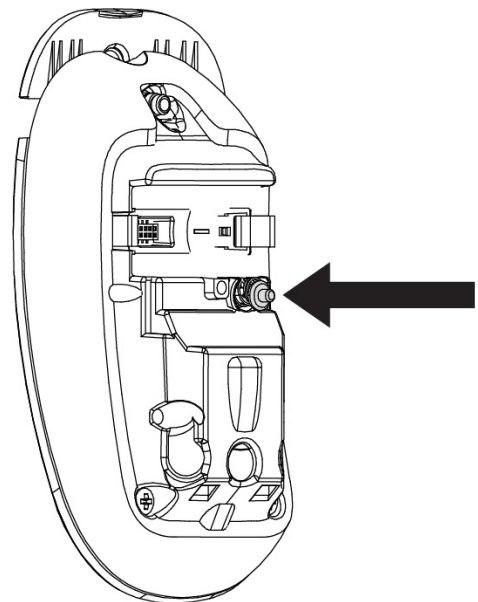

Figure 7 Press the tamper button

2. Wait for the green LED to blink five times, then:
  - Press the tamper button one time within three seconds to select single pulse count.
  - Press the tamper button two times within three seconds to select automatic pulse count.
3. Confirm your selection.
  - The green LED will blink once to indicate single pulse count has been selected; twice to confirm automatic pulse count has been selected.

## 2.4 Select Sleep Cycle Duration

The EN1342-60 sends two types of message: alarm and check-in. Alarm messages are sent when the EN1342-60 first detects motion. Immediately upon sending an alarm message, the EN1342-60 enters the selected sleep cycle, during which no more alarm messages are sent. Check-in messages are sent by the EN1342-60 every 60 minutes, even during the sleep cycle, to ensure the EN1342-60 is still functional. Check-in messages also include the alarm status as part of the check-in information.

Typically, activity monitoring in senior living environments is performed using a daily time window to confirm resident activity. The EN1342-60 sleep interval can be set to two, four, or six hours. If you require multiple alarms during your daily time window you should select a sleep time shorter than your daily time window.

To set sleep cycle duration:

1. Press the tamper button four times within three seconds.
2. Wait for the green LED to blink four times, then:
  - For two hours press the tamper button two times within three seconds.
  - For four hours press the tamper button four times within three seconds.
  - For six hours press the tamper button six times within three seconds.
3. Confirm your selection.
  - The green LED will blink two times to indicate two hours has been selected, four times to indicate four hours has been selected and six times to indicate six hours has been selected.

## 2.5 Register the Transmitter

The EN1342-60 must be registered with the system receiver in order to be monitored and supervised. Each EN1342-60 has a unique factory-programmed identification number. Refer to the receiver, network coordinator or control panel installation instructions for details on registering a transmitter.

1. When prompted to reset the transmitter, press the tamper button.
2. Replace the housing cover.

---

**Caution:** The EN1342-60 should be tested after registration to ensure operation. To test, activate each of the conditions and ensure an appropriate response.

---

## 3 Test the EN1342-60

When in walk test mode the test LED will light red every time the EN1342-60 senses motion. The unit will not transmit alarm signals during this test period. Once initiated, the walk test will last for ten minutes and then the EN1342-60 will automatically return to normal operation. To initiate a walk test:

1. Press the tamper button three times within three seconds.

---

**Note:** The test LED only lights red during the walk test.

---

## 4 Specifications

Dimensions: 4.25" x 2.28" x 1.7" (108 mm x 58 mm x 43 mm).

Weight: 3.2 ounces (90 grams).

Operating temperature: 32°F to 120°F (0°C to 49°C).

Humidity: 0 to 93% (non-condensing).

Battery (BAT604): CR123A or equivalent.

Typical battery life: Two years.

Tamper: Housing and/or Wall (optional).

PIR: Quad Element PIR.

Coverage area: 26ft (8m).

Warm up period: 40 seconds.

Check-in time: 60 minutes.

Regulatory compliance: UL 2560 Unlisted Component, FCC/ISED, RoHS, RCM.

Compatible receiver for UL 2560 installations: EN6080 or EN6040-T.

Compatible repeater for UL 2560 installations: EN5040-20T.

---

**Note:** The EN1342-60 is a supplemental device that can be installed in a UL 2560 certified system.

---

## 5 Television and Radio Interference

This equipment has been tested and found to comply with the limits for a Class B digital device, pursuant to Part 15 of the FCC Rules. These limits are designed to provide reasonable protection against harmful interference

in a residential installation. This equipment generates, uses and can radiate radio frequency energy and, if not installed and used in accordance with the instructions, may cause harmful interference to radio communications. However, there is no guarantee that interference will not occur in a particular installation. If this equipment does cause harmful interference to radio or television reception, which can be determined by turning the equipment off and on, the user is encouraged to try to correct the interference by one or more of the following measures:

- Reorient or relocate the receiving antenna.
- Increase the separation between the equipment and receiver.
- Connect the equipment into an outlet on a circuit different from that to which the receiver is connected.
- Consult the dealer or an experienced radio/TV technician for help.

## 6 FCC Part 15 and Innovation, Science and Economic Development Canada (ISED) Compliance

This device complies with part 15 of the FCC Rules, and ISED license-exempt RSS standard(s). Operation is subject to the following two conditions: (1) this device may not cause interference, and (2) this device must accept any interference that may cause undesired operation of the device.

Le présent appareil est conforme aux CNR Innovation, Sciences et Développement économique Canada applicables aux appareils radio exempts de licence. L'exploitation est autorisée aux deux conditions suivantes: (1) l'appareil ne doit pas produire de brouillage, et (2) l'utilisateur de l'appareil doit accepter tout brouillage radioélectrique subi, même si le brouillage est susceptible d'en compromettre le fonctionnement.

---

**Caution:** Changes or modifications not expressly approved by the party responsible for compliance could void the user's authority to operate the equipment.

---

## 7 Radiation Exposure Limits

### 7.1 FCC

This equipment complies with FCC radiation exposure limits set forth for an uncontrolled environment. In order to avoid the possibility of exceeding the FCC radio frequency exposure limits, human proximity to the antenna shall not be less than 20 cm during normal operation and must not be co-located or operating in conjunction with any other antenna or transmitter.

### 7.2 ISED

This equipment complies with ISED RSS-102 radiation exposure limits set forth for an uncontrolled environment. This transmitter must be installed to provide a separation distance of at least 20 cm from all persons and must not be co-located or operating in conjunction with any other antenna or transmitter.

Cet équipement est conforme avec ISED RSS-102 des limites d'exposition aux rayonnements définies pour un environnement non contrôlé. Cet émetteur doit être installé à au moins 20 cm de toute personne et ne doit pas être colocalisé ou fonctionner en association avec une autre antenne ou émetteur.