



# EN1252 Long Range Dual Input Universal Transmitter Installation Instructions

## 1 Overview

The EN1252 long range dual input universal transmitter provides five times the power of a standard Inovonics universal transmitter. It is designed for use with any standard contact or sensor that provides a contact closure. The primary alarm input is selectable – normally open or closed – and the secondary alarm input is set to normally closed only. It can also be removed from the housing and interfaced with your electronic remote application controller, enabling it to send your application-specific data over the Inovonics wireless network.

### 1.1 Inovonics Contact Information

If you have any problems with this procedure, contact Inovonics technical services:

- E-mail: support@inovonics.com.
- Phone: (800) 782-2709; (303) 939-9336.

### 1.2 EN1252 Internal Components

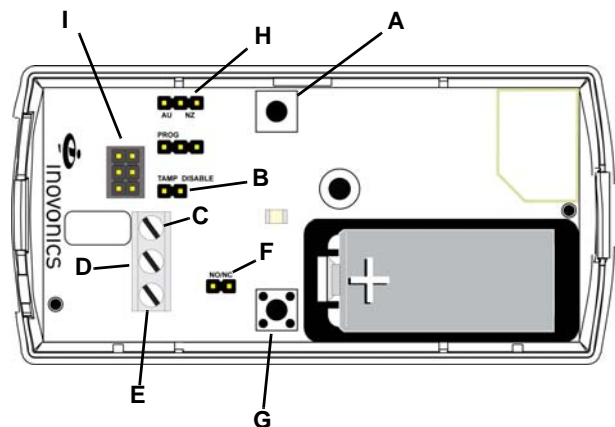

Figure 1 EN1252 internal components

- A Reset button
- B Tamper disable selection pins
- C Input two terminal (N/C)
- D Ground terminal
- E Input one terminal (N/O or N/C)
- F NO/NC selection pins (input 1 only)
- G Housing tamper button
- H Frequency band selection pins
- I OEM connector

## 1.3 OEM Connector Pinout

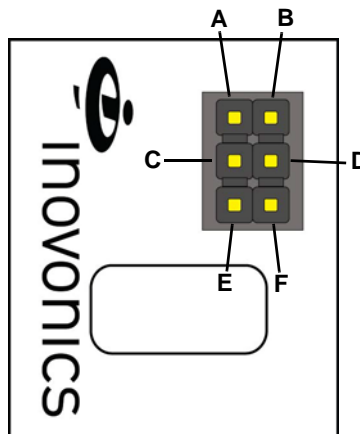

Figure 2 OEM connector pinout

- A Power
- B Ground
- C Reset
- D Primary alarm
- E Tamper
- F Secondary alarm

**Note:** The EN1252 OEM connector (6-pin/2x3) mounted to the printed circuit board receives a Molex connector with 2mm lead spacing. This part can be purchased from Digi-Key using the part number WM18577-ND.

## 1.4 What's In the Carton

- One 3.0V lithium battery, Inovonics part number BAT604.
- Three drywall anchors.
- Three mounting screws.

## 2 Installation and Startup

### 2.1 Installation Notes

- These products are designed to be maintained by professional security technicians.
- Products are tested for indoor use.
- All products should be manually tested weekly.

### 2.2 Install the Battery

1. Pry the top lip of the mounting bracket up, and lift the bracket off of the transmitter.
2. Use your thumb to depress the housing release tab on the bottom of the transmitter; separate the housing.
3. Install the battery.

### 2.3 Connect Input Wiring

The transmitter has a three-terminal contact block that can connect inputs from one or two external contact loops. The middle terminal is a ground, which is shared by both contact loops. Input one can be configured for either a normally open or a normally closed contact loop using the NO/NC selection pins; input two is always normally closed.

4. Connect cabling to input one and/or input two, as desired.

## 2.4 Select the Frequency Band

EchoStream products are able to use a range of radio frequencies, and must be configured for your geographic area. This product ships with a default frequency range of 902-928 MHz for use in North America. If you are using the product in North America, skip to 2.5, "Select Input Type"; if you are using the product in Australia or New Zealand, you will need to configure the transmitter.

5. Place a selection jumper on the frequency band selection pins appropriate to your geographic area.
  - Place the jumper on the right two pins, marked NZ, to set the frequency range to 921-928 MHz for New Zealand
  - Place the jumper on the left two pins, marked AUS, to set the frequency range to 915-928 MHz for Australia.
6. Press the reset button to complete configuration.

**Caution:** When pressing the reset button, make sure you don't also touch the frequency band selection pins. Touching the frequency band selection pins while pressing the reset button can inadvertently set the device to the wrong frequency band.

## 2.5 Select Input Type

The N/O-N/C selection pins allow the choice of a normally open or normally closed state for the contact circuit wired to the input one terminal. The terminal is shipped set for normally closed, with no selection jumper on the N/O selections pins. If you need the input one terminal set for normally closed, no action is needed; skip to 2.6, "Enable/Disable Housing Tamper".

7. Place a selection jumper on the selection pins to select normally open.

## 2.6 Enable/Disable Housing Tamper

The tamper disable selection pins allow the housing tamper to be disabled. If you do not wish to disable the tamper, no action is needed; skip to 2.7, "Register the EN1252". If you wish to disable the housing tamper:

8. Place a selection jumper on the tamper disable selection pins to disable the housing tamper.
9. Press the reset button to complete configuration.

**Caution:** When pressing the reset button, make sure you don't also touch any selection pins. Touching selection pins while pressing the reset button can inadvertently set the EN1252 to an undesired configuration.

## 2.7 Register the EN1252

Transmitters must be registered with the system in order to be monitored and supervised. When supervised, the transmitter will send a check-in message to the receiver. Transmitters will send a check-in message every three minutes. Each transmitter has a unique factory-programmed identification number.

**Note:** Refer to the receiver installation instructions for details about registering a transmitter.

10. When prompted by the receiver to reset transmitter, press the reset button.
11. Replace the cover.

**Caution:** The EN1252 should be tested after registration to ensure operation. To test the EN1252, activate each of the conditions and ensure an appropriate response.

## 2.8 Mount the EN1252

12. Mount the bracket on the wall with the screws provided so that the catch is on the bottom.
13. Clip the transmitter onto the bracket. Hook the bottom catch first, then press the top into place.

## 3 Specifications

Dimensions: 3.5x1.7x0.9".

Weight: 1.5 oz.

Typical battery life: 1 – 2 years (This does not include current drawn by external devices).

Internal battery type: 3.0V lithium battery, Inovonics part number BAT604.

RF output power: 24 dBm (250 milliwatts) equivalent isotropically radiated power.

Minimum input hold time: 100 ms

Operating environment: Temperature: -4°F to 140°F using internal battery (-40°F to 185°F using appropriate external power source).

Humidity: Up to 90% (non-condensing).

Market: North America, Australia, New Zealand.

EchoStream® frequency: 902-928 MHz, Frequency hopping spread spectrum.

Regulatory compliance: FCC, Industry Canada, RoHS.

---

**Note:** Specifications and data are subject to change without notice.

---

## 4 Television and Radio Interference

This equipment has been tested and found to comply with the limits for a Class B digital device, pursuant to Part 15 of the FCC Rules. These limits are designed to provide reasonable protection against harmful interference in a residential installation. This equipment generates, uses and can radiate radio frequency energy and, if not installed and used in accordance with the instructions, may cause harmful interference to radio communications. However, there is no guarantee that interference will not occur in a particular installation. If this equipment does cause harmful interference to radio or television reception, which can be determined by turning the equipment off and on, the user is encouraged to try to correct the interference by one or more of the following measures:

- Reorient or relocate the receiving antenna.
- Increase the separation between the equipment and receiver.
- Connect the equipment into an outlet on a circuit different from that to which the receiver is connected.
- Consult the dealer or an experienced radio/TV technician for help.

## 5 Compliance Information

This device complies with part 15 of the FCC Rules and Industry Canada license-exempt RSS standard(s). Operation is subject to the following two conditions: (1) this device may not cause interference, and (2) this device must accept any interference, including interference that may cause undesired operation of the device.

Le présent appareil est conforme aux CNR d'Industrie Canada applicables aux appareils radio exempts de licence. L'exploitation est autorisée aux deux conditions suivantes : (1) l'appareil ne doit pas produire de brouillage, et (2) l'utilisateur de l'appareil doit accepter tout brouillage radioélectrique subi, même si le brouillage est susceptible d'en compromettre le fonctionnement.

---

**Note:** Changes or modifications not expressly approved by the party responsible for compliance could void the user's authority to operate the equipment.

---

## 5.1 Compliance Notification

The integrator is responsible to ensure the final configuration is in compliance with the applicable FCC and IC regulations. This module is limited to battery powered operation only. Connection to the AC power lines, either directly or through another device, requires a separate approval from the modular approval obtained by Inovonics. The integrator is instructed to verify compliance with the applicable requirements for modular transmitters. The integrator is responsible for properly labeling the product containing the module. Product labels must be permanently affixed on the exterior of the enclosure containing the module. Labels must include a statement indicating the product contains the module and the label must specify the FCC and IC identification numbers:

Example 1: "Contains RF Module - FCC ID: HCQ3B6OT9HPX / IC ID: 2309A-0T9HPX"

Example 2: "Contains FCC ID: HCQ3B6OT9HPX / IC ID: 2309A-0T9HPX"

---

**Caution:** To maintain compliance to FCC RF exposure guidelines, install the module at least 20 centimeters (7.8 inches) from the body of the user or nearby persons. The module may not be co-located with any other transmitters or antennas except in accordance with FCC multi-transmitter procedures.

---

## 6 US Patent Numbers

- 7,154,866.
- 7,554,932.
- 7,746,804.
- Other patents pending.