



## TEST REPORT – EMC Emissions

Report Number: 100115937DEN-002B

Project Number: 100115937

Report Issue Date: 6/23/2010

**Product Designation:** Model: AV420

**Standards:** FCC CFR47 Part 15, Subpart C  
FCC Part 15.249  
IC RSS-210e Issue 7: 2007  
IC RSS-GEN Issue 2: 2007

Tested by:  
Intertek Testing Services NA, Inc.  
1795 Dogwood Street, Suite 200  
Louisville, CO 80027

Emissions Testing Facility  
40 Meadow Rd  
Pinewood Springs, CO 80540

Client:  
Inovonics Wireless Corporation  
315 CTC Blvd.  
Louisville, CO 80027

Report prepared by

Randy Thompson  
Senior EMC Project Engineer

Report reviewed by

Michael Spataro  
Engineering Team Leader

*This report is for the exclusive use of Intertek's Client and is provided pursuant to the agreement between Intertek and its Client. Intertek's responsibility and liability are limited to the terms and conditions of the agreement. Intertek assumes no liability to any party, other than to the Client in accordance with the agreement, for any loss, expense or damage occasioned by the use of this report. Only the Client is authorized to permit copying or distribution of this report and then only in its entirety. Any use of the Intertek name or one of its marks for the sale or advertisement of the tested material, product or service must first be approved in writing by Intertek. The observations and test results in this report are relevant only to the sample tested. This report by itself does not imply that the material, product, or service is or has ever been under an Intertek certification program.*

**TABLE OF CONTENTS**

<b>Section</b>	<b>Page</b>
<b>1 Introduction and Conclusion .....</b>	<b>4</b>
<b>2 Test Summary .....</b>	<b>4</b>
<b>3 Description of Equipment Under Test.....</b>	<b>6</b>
<b>4 System setup including cable interconnection details, support equipment and simplified block diagram .....</b>	<b>7</b>
<b>5 Radiated Emissions – Intentional: Field Strength of the Fundamental &amp; Harmonics of the Fundamental .....</b>	<b>9</b>
<b>6 AC Conducted Emissions – Not applicable to this test report.....</b>	<b>19</b>
<b>7 Measurement Uncertainty .....</b>	<b>20</b>
<b>8 Revision History.....</b>	<b>21</b>

**Product Under Test**

Model: AV420 (Quasar Base Station)



**1 Introduction and Conclusion**

The tests indicated in section 2.0 were performed on the product constructed as described in section 3.0. The remaining test sections are the verbatim text from the actual data sheets used during the investigation. These test sections include the test name, the specified test Method, a list of the actual Test Equipment Used, documentation Photos, Results and raw Data. No additions, deviations, or exclusions have been made from the standard(s) unless specifically noted.

Based on the results of our investigation, **we have concluded the product tested complies with the requirements of the standard(s) indicated.** The results obtained in this test report pertain only to the item(s) tested.

**2 Test Summary**

Section	Test full name	Test date	Result
5	Radiated Emissions – Intentional per FCC Part 15.249(a) (Covers IC RSS-210: Annex 2.9(a))	05/14/10	Pass
6	Conducted Emissions –	-----	-----

Notes:

1. Only Intentional Radiated Emissions was tested and listed in this report per client request. Unintentional Radiated Emissions and Conducted Emissions for this product was also tested and passed. Please refer to Report Number: 100115937DEN-001.

**General Remarks for Radio Testing:**

The following remarks are to be considered as “where applicable” and are taken into account while completing any FCC/IC/ETSI Radio tests at Intertek-Louisville.

- Testing was performed in 3 different orthogonal axes to determine the worst-case emissions from the device. The worst-case emissions are shown in this report.
- FCC CFR47 Part 15.31: Measurement Standards: In any case where the device is powered off a battery, a fresh battery was used during testing. In cases where the device is powered of an AC Supply, voltage was varied per Part 15.31 to find worst-case emissions.
- FCC CFR Part 15.35: Measurement Detector Functions and Bandwidths: FCC Part 15.35 was utilized when performing measurements within this report.
- The testing performed in accordance to FCC CFR47 Part 15.205 (restricted bands of operation) and Part 15.249 emissions and delta limits were calculated as follows:

Final Corrected Peak Measurement – Duty Cycle Correction Factor\* = Final Calculated Emission  
The Final Calculated Emission was then compared to the Limits in CFR47 Part 15.209 and Part 15.249 and the emission/limit delta was calculated.

- When applicable, the “Duty Cycle Correction Factor” (DTCF) is calculated as follows:  $20 \times \text{Log}_{10}$  (duty cycle in 100ms) “not to exceed 20 dB”
- If the antenna is external and detachable, a conducted port power measurement may be taken directly at the antenna port whenever a conducted power limit is specified.
- If the antenna is internal and not detachable, radiated field strength measurements were taken at a calibrated open area test site.
- The following formula may be used to convert field strength (FS) in volts/meter to transmitter power (TP) output power in watts:  $TP = (FS \times D)^2 / (30 \times G)$ , where D is test distance (EUT-to-antenna) and G is the product’s antenna numerical gain referenced to isotropic gain.
- If at the time of testing Intertek was unable to obtain the gain of the product’s antenna from the manufacturer, the following calculation may be used to determine field strength limit for a test distance of 3-meters. This calculation assumes ideal isotropic radiation from the source:

$$P = 20 \times \text{Log}_{10}(E) - 95.2289$$

Where P is power in dBm, E is uV/m

**3 Description of Equipment Under Test**

Equipment Under Test			
Description	Manufacturer	Model Number	Serial Number
Quasar Base Station	Inovonics	AV420	16594728

Receive Date:	05/12/2010
Received Condition:	Good
Type:	Production Proto

**Description of Equipment Under Test (provided by client)**

The product is intended to be used in office, commercial and industrial locations, in a dry environment. The primary function of the product is a headset transceiver capable of operating in the frequency range of 902 – 928 MHz. The product has no external RF conducted port and utilizes (2) internal antennas. RF is FM modulation, 16-channels, 1 discrete frequency/channel and can operate in CW mode. The product enclosure is plastic. Product will be marketed in the US and Canada. Note that power for this product is supplied by a client-sourced 12-14VDC power supply.

Equipment Under Test Power Configuration			
Rated Voltage	Rated Current	Rated Frequency	Number of Phases
12-14 VDC	unknown	-----	-----

**Operating modes of the EUT:**

No.	Descriptions of EUT Exercising
1	Product Tx enabled at full transmit power, continuous wave (CW) mode.

**4 System setup including cable interconnection details, support equipment and simplified block diagram**

**4.1 Method:**

Record the details of EUT cabling, document the support equipment, and show the interconnections in a block diagram.

**4.2 EUT Block Diagram: Model – AV420**

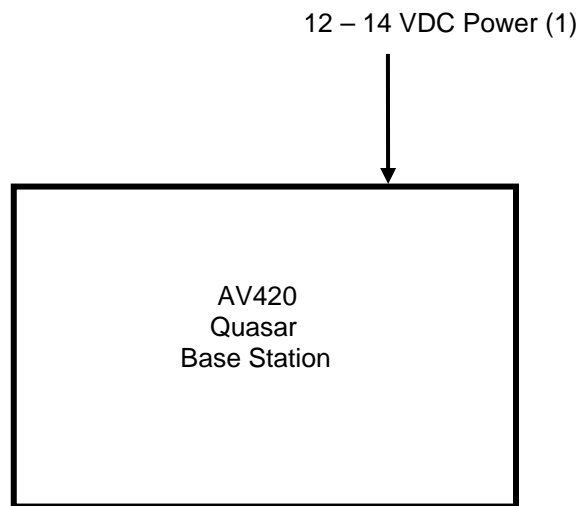

**4.3 Data:**

ID	Cable Description	Length	Shielding	Ferrites
1	VDC Supply Cable- AC Adapter	1.5 meter	none	none

Support Equipment			
Description	Manufacturer	Model Number	Serial Number
None	---	---	---

General notes:

1. Product had no I/O or signal cables attached.
2. Product did not require any support equipment.



## 5 Radiated Emissions – Intentional: Field Strength of the Fundamental & Harmonics of the Fundamental

### 5.1 Method

The test methods used comply with ANSI C63.4 and CISPR 16. Unless otherwise stated no deviations were made from **FCC CFR47, Part 15C per FCC 15.249**.

Intertek Louisville's emissions testing facility is located at 40 Meadow Rd. in Pinewood Springs CO 80540. The emissions testing facility is ISO17025:2005 accredited by NVLAP, our lab code is 200624-0, BSMI lab number is SL2-IN-E-029R, our VCCI registration no. R-1643, our FCC designation no. US5170 and our IC lab no. 2042N.

### 5.2 Test Equipment Used:

<u>Asset ID:</u>	<u>Description:</u>	<u>Manufacturer:</u>	<u>Model:</u>	<u>Serial:</u>	<u>Cal Date</u>	<u>Cal Due</u>
18882	Spectrum Analyzer (dc-22 GHz) Spectrum Analyzer Display	Hewlett-Packard	8566B	2410A00154	11/12/2009	11/12/2010
18660	Section (set 1)	Hewlett-Packard	85662A	2318A04983	11/12/2009	11/12/2010
18912	9 kHz- 1.3GHz Pre Amp	Hewlett-Packard	8447F	3113A05545	05/12/2009	06/12/2011
18906	Amplifier (1-4 GHz)	Mini-Circuits Lab	ZHL-42	N052792-2	05/12/2009	06/11/2011
18900	RF Pre-Amplifier (4-8 GHz)	Avantek	AFT97-8434-10F	1007	05/12/2009	06/07/2011
18901	RF Pre-Amplifier (8-18 GHz)	Avantek	AWT-18037	1002	05/12/2009	06/07/2011
18808	Log Periodic Antenna Doubled Ridged Guide Antenna	EMCO	3146	9203-3376	11/05/2009	11/05/2010
18737	(1-18 GHz)	EMCO	3105	2076	06/03/2009	06/03/2010

### 5.3 Results:

The sample tested was found to Comply.

**5.4 Setup Photographs:**

Radiated Emissions Test setup – Front View



**Photo:**

Radiated Emissions Test setup – Rear View



**Photo:**

Test setup – Axis 1 (EUT Flat on Table)



**Photo:**

Test setup – Axis 2 (EUT Vertical)



**Photo:**

Test setup – Axis 3 (EUT Vertical & Rotated 90 Degrees)



**Note: Axis 3 was determined to be worst-case**

**5.5 Test Data Summary: Radiated Unintentional and Spurious Emissions:**

Test Result: Not Applicable to this test report

Minimum limit margin ----- dB at ----- MHz

Remarks:

Note: Unintentional Radiated Emissions was previously tested and passed. Refer to Report 100115937DEN-001 for details.

**5.6 Test Data Summary: Power Line Conducted Emissions:**

Test Result: Not Applicable to this test report

Minimum limit margin ----- dB at ----- MHz

Remarks:

Note: Conducted Emissions was previously tested and passed. Refer to Report 100115937DEN-001 for details.

**5.7 Test Data Summary: Field Strength of the Fundamental: FCC 15.249 (a)**

**Test Result: Pass**

Minimum limit margin – Low Channel - 1.4 dB at 922.80 MHz

Remarks: Covers RSS-210, Annex 2.9 (a)

**5.8 Test Data Summary: Field Strength of the Harmonics of Fundamental:  
FCC 15.249 (a) / 15.205**

**Test Result: Pass**

Minimum limit margin – Low Channel - 3.8 dB at 3691.2 MHz

Remarks: Covers RSS-210, Annex 2.9 (a)

## Field Strength Measurements Fundamental and Harmonics of the Fundamental

Test Report #: <u>100115937 Run 01</u>	Test Area: <u>Pinewood Site 1 (3m)</u>	Temperature: <u>24.5</u> °C
Test Method: <u>FCC 15.249/ IC RSS-210</u>	Test Date: <u>14-May-2010</u>	Relative Humidity: <u>29.8</u> %
EUT Model #: <u>AV420</u>	EUT Power: <u>12-14 VDC</u>	Air Pressure: <u>79.9</u> kPa
EUT Serial #: <u>16594728</u>		

Manufacturer: <u>Inovonics</u>	<b>Level Key</b>
EUT Description: <u>Quasar Base Station</u>	Pk – Peak                      Nb – Narrow Band
Notes: <u>Tested at full Tx power</u>	Qp – QuasiPeak              Bb – Broad Band
<u>Product configured for Tx Frequency Range 922.80 MHz to 927.60 MHz</u>	Av - Average

FREQ	LEVEL	CABLE / ANT / PREAMP	FINAL	POL / HGT / AZ	Duty Cycle Correction	Final Corrected	Limit	DELTA
(MHz)	(dBuV)	(dB) (dBm) (dB)	(dBuV)	(m) (DEG)	(dB)	(dBuV/m)	(dBuV/m)	(dB)

The following Duty Cycle was declared by the manufacturer: 100 %

**Averaging method for pulsed signals and calculation in accordance to FCC CFR47 Part 15.35 utilized to calculate field strength emissions.**

The testing performed in accordance to FCC CFR47 Part 15.205 (restricted bands of operation) and 15.249 emissions and delta limits were calculated as follows:

Final Corrected Peak Measurement – Duty Cycle Correction Factor\* = Final Calculated Emission

The Final Calculated Emission was then compared to the Limits in CFR47 Part 15.209 and 15.249 and the emission/limit delta was calculated.

Duty Cycle Correction Factor (DTCF) is calculated as follows  $20 \cdot \log_{10}(\text{duty cycle in 100ms})$  "not to exceed 20dB"

**Part 15.249 and 15.209 Respectively**

**Fundamental Measurements**

**Low Channel Axis 1 - EUT is Flat on the table.**

922.8	61.0 Pk	3.6 / 22.5 / 0.0	87.2	V / 1.2 / 20.0	0.0	87.2	94.0	-6.8
922.8	65.5 Pk	3.6 / 22.5 / 0.0	91.7	H / 1.6 / 76.0	0.0	91.7	94.0	-2.3

**Axis 2 - EUT is Vertical on the table.**

922.8	63.8 Pk	3.6 / 22.5 / 0.0	90.0	H / 1.4 / 18.0	0.0	90.0	94.0	-4.0
922.8	64.9 Pk	3.6 / 22.5 / 0.0	91.1	V / 1.2 / 112.0	0.0	91.1	94.0	-2.9

**Axis 3 - EUT is Vertical on the table & Rotated 90 Deg.**

922.8	64.8 Pk	3.6 / 22.5 / 0.0	91	V / 1.4 / 354.0	0.0	91.0	94.0	-3.0
922.8	66.4 Pk	3.6 / 22.5 / 0.0	92.6	H / 1.6 / 28.0	0.0	92.6	94.0	-1.4

**Mid Channel Axis 1**

925.92	63.4 Pk	3.6 / 22.6 / 0.0	89.5	H / 1.4 / 42.0	0.0	89.5	94.0	-4.5
925.92	63.5 Pk	3.6 / 22.6 / 0.0	89.7	V / 1.5 / 110.0	0.0	89.7	94.0	-4.3

**Axis 2**

925.92	63.5 Pk	3.6 / 22.6 / 0.0	89.7	V / 1.1 / 115.0	0.0	89.7	94.0	-4.3
925.92	63.9 Pk	3.6 / 22.6 / 0.0	90.1	H / 1.4 / 16.0	0.0	90.1	94.0	-3.9

**Axis 3**

925.92	66.0 Pk	3.6 / 22.6 / 0.0	92.1	H / 1.6 / 22.0	0.0	92.1	94.0	-1.9
925.92	64.0 Pk	3.6 / 22.6 / 0.0	90.2	V / 1.4 / 348.0	0.0	90.2	94.0	-3.8



# Intertek

Report Number: 100115937DEN-002B

Issued: 6/23/2010

FREQ	LEVEL	CABLE / ANT / PREAMP	FINAL	POL / HGT / AZ	Duty Cycle Correction	Final Corrected	Limit	DELTA
(MHz)	(dBuV)	(dB) (dBm) (dB)	(dBuV)	(m) (DEG)	(dB)	(dBuV/m)	(dBuV/m)	(dB)
<b>High Channel Axis 1</b>								
927.6	64.9 Pk	3.6 / 22.6 / 0.0	91.1	V / 1.4 / 110.0	0.0	91.1	94.0	-2.9
927.6	61.2 Pk	3.6 / 22.6 / 0.0	87.4	H / 1.4 / 356.0	0.0	87.4	94.0	-6.6
<b>Axis 2</b>								
927.6	63.4 Pk	3.6 / 22.6 / 0.0	89.5	H / 1.5 / 16.0	0.0	89.5	94.0	-4.5
927.6	63.5 Pk	3.6 / 22.6 / 0.0	89.6	V / 1.1 / 115.0	0.0	89.6	94.0	-4.4
<b>Axis 3</b>								
927.6	63.6 Pk	3.6 / 22.6 / 0.0	89.8	V / 1.4 / 315.0	0.0	89.8	94.0	-4.2
927.6	66.2 Pk	3.6 / 22.6 / 0.0	92.4	H / 1.6 / 22.0	0.0	92.4	94.0	-1.6
<b>Axis 3 was determined to be the worst case axis</b>								
<b>All Harmonics will be measured in Axis 3</b>								
<b>Harmonics - Low Channel</b>								
1845.6	48.7 Pk	2.8 / 26.1 / 35.8	41.8	V / 1.2 / 320.0	0.0	41.8	54.0	-12.2
1845.6	48.5 Pk	2.8 / 26.1 / 35.8	41.7	H / 1.2 / 22.0	0.0	41.7	54.0	-12.3
2768.4	51.1 Pk	3.5 / 28.3 / 36.7	46.2	V / 1.2 / 332.0	0.0	46.2	54.0	-7.8
2768.4	47.3 Pk	3.5 / 28.3 / 36.7	42.4	H / 1.5 / 248.0	0.0	42.4	54.0	-11.6
3691.2	51.8 Pk	4.5 / 31.1 / 37.3	50.2	V / 1.1 / 342.0	0.0	50.2	54.0	<b>-3.8</b>
3691.2	50.5 Pk	4.5 / 31.1 / 37.3	48.9	H / 1.6 / 24.0	0.0	48.9	54.0	-5.1
4614	43.9 Pk	5.4 / 32.0 / 39.7	41.5	H / 1.6 / 349.0	0.0	41.5	54.0	-12.5
4614	42.5 Pk	5.4 / 32.0 / 39.7	40.2	V / 1.2 / 16.0	0.0	40.2	54.0	-13.8
5536.8	39.9 Pk	6.1 / 32.9 / 39.3	39.7	H / 1.2 / 46.0	0.0	39.7	54.0	-14.3
5536.8	36.8 Pk	6.1 / 32.9 / 39.3	36.5	V / 1.1 / 350.0	0.0	36.5	54.0	-17.5
6459.6	34.2 Pk	6.8 / 33.9 / 39.4	35.4	H / 1.2 / 354.0	0.0	35.4	54.0	-18.6
6459.6	31.4 Pk	6.8 / 33.9 / 39.4	32.6	V / 1.1 / 354.0	0.0	32.6	54.0	-21.4
7382.4	36.7 Pk	7.4 / 35.4 / 39.6	39.9	H / 1.1 / 354.0	0.0	39.9	54.0	-14.1
7382.4	35.5 Pk	7.4 / 35.4 / 39.6	38.7	V / 1.1 / 12.0	0.0	38.7	54.0	-15.3
8305.2	37.4 Pk	8.0 / 36.4 / 46.6	35.1	V / 1.0 / 8.0	0.0	35.1	54.0	-18.9
8305.2	40.6 Pk	8.0 / 36.4 / 46.6	38.4	H / 1.0 / 8.0	0.0	38.4	54.0	-15.6
9228	39.0 Pk	8.5 / 36.9 / 47.7	36.7	V / 1.0 / 8.0	0.0	36.7	54.0	-17.3
9228	34.6 Pk	8.5 / 36.9 / 47.7	32.3	H / 1.0 / 8.0	0.0	32.3	54.0	-21.7
<b>Harmonics - Mid Channel</b>								
1851.84	48.0 Pk	2.9 / 26.1 / 35.8	41.1	H / 1.2 / 334.0	0.0	41.1	54.0	-12.9
1851.84	47.4 Pk	2.9 / 26.1 / 35.8	40.5	V / 1.2 / 328.0	0.0	40.5	54.0	-13.5
2777.76	47.0 Pk	3.5 / 28.3 / 36.7	42.2	H / 1.8 / 54.0	0.0	42.2	54.0	-11.8
2777.76	50.5 Pk	3.5 / 28.3 / 36.7	45.6	V / 1.1 / 324.0	0.0	45.6	54.0	-8.4
3703.68	50.5 Pk	4.5 / 31.1 / 37.2	48.9	H / 1.3 / 220.0	0.0	48.9	54.0	-5.1
3703.68	49.6 Pk	4.5 / 31.1 / 37.2	48.0	V / 1.1 / 348.0	0.0	48.0	54.0	-6.0
4629.6	42.5 Pk	5.4 / 32.0 / 39.7	40.2	V / 1.2 / 10.0	0.0	40.2	54.0	-13.8
4629.6	44.1 Pk	5.4 / 32.0 / 39.7	41.8	H / 1.3 / 5.0	0.0	41.8	54.0	-12.2
5555.52	37.9 Pk	6.1 / 33.0 / 39.3	37.7	V / 1.2 / 328.0	0.0	37.7	54.0	-16.3
5555.52	38.0 Pk	6.1 / 33.0 / 39.3	37.8	H / 1.4 / 322.0	0.0	37.8	54.0	-16.2
6481.44	30.8 Pk	6.8 / 33.9 / 39.4	32.0	V / 1.2 / 328.0	0.0	32.0	54.0	-22.0

# Intertek

Report Number: 100115937DEN-002B

Issued: 6/23/2010

FREQ	LEVEL	CABLE / ANT / PREAMP	FINAL	POL / HGT / AZ	Duty Cycle Correction	Final Corrected	Limit	DELTA
(MHz)	(dBuV)	(dB) (dBm) (dB)	(dBuV)	(m) (DEG)	(dB)	(dBuV/m)	(dBuV/m)	(dB)
6481.44	30.8 Pk	6.8 / 33.9 / 39.4	32.1	H / 1.2 / 8.0	0.0	32.1	54.0	-21.9
7407.36	34.1 Pk	7.4 / 35.4 / 39.6	37.4	V / 1.2 / 8.0	0.0	37.4	54.0	-16.6
7407.36	35.0 Pk	7.4 / 35.4 / 39.6	38.2	H / 1.2 / 8.0	0.0	38.2	54.0	-15.8
8333.28	35.2 Pk	8.0 / 36.4 / 46.6	33.0	H / 1.0 / 8.0	0.0	33.0	54.0	-21.0
9259.2	40.0 Pk	8.5 / 36.9 / 47.7	37.7	H / 1.0 / 8.0	0.0	37.7	54.0	-16.3
9259.2	38.0 Pk	8.5 / 36.9 / 47.7	35.7	V / 1.0 / 8.0	0.0	35.7	54.0	-18.3
9259.2	34.8 Pk	8.5 / 36.9 / 47.7	32.4	V / 1.0 / 8.0	0.0	32.4	54.0	-21.6
<b>Harmonics - High Channel</b>								
1855.2	46.8 Pk	2.9 / 26.1 / 35.8	40.0	V / 1.2 / 320.0	0.0	40.0	54.0	-14.0
1855.2	45.7 Pk	2.9 / 26.1 / 35.8	38.9	H / 1.3 / 324.0	0.0	38.9	54.0	-15.1
2782.8	50.4 Pk	3.5 / 28.3 / 36.7	45.5	V / 1.1 / 312.0	0.0	45.5	54.0	-8.5
2782.8	48.5 Pk	3.5 / 28.3 / 36.7	43.6	H / 1.2 / 54.0	0.0	43.6	54.0	-10.4
3710.4	48.9 Pk	4.5 / 31.1 / 37.2	47.3	V / 1.1 / 342.0	0.0	47.3	54.0	-6.7
3710.4	49.3 Pk	4.5 / 31.1 / 37.2	47.7	H / 1.4 / 32.0	0.0	47.7	54.0	-6.3
4638.0	44.5 Pk	5.4 / 32.0 / 39.7	42.2	H / 1.2 / 8.0	0.0	42.2	54.0	-11.8
4638.0	41.0 Pk	5.4 / 32.0 / 39.7	38.7	V / 1.2 / 9.0	0.0	38.7	54.0	-15.3
5565.6	38.4 Pk	6.1 / 33.0 / 39.3	38.2	H / 1.1 / 38.0	0.0	38.2	54.0	-15.8
5565.6	36.9 Pk	6.1 / 33.0 / 39.3	36.6	V / 1.3 / 352.0	0.0	36.6	54.0	-17.4
6493.2	33.0 Pk	6.8 / 33.9 / 39.4	34.2	H / 1.1 / 38.0	0.0	34.2	54.0	-19.8
6493.2	31.4 Pk	6.8 / 33.9 / 39.4	32.6	V / 1.1 / 12.0	0.0	32.6	54.0	-21.4
7420.8	34.0 Pk	7.4 / 35.5 / 39.6	37.4	H / 1.1 / 38.0	0.0	37.4	54.0	-16.6
7420.8	35.0 Pk	7.4 / 35.5 / 39.6	38.3	V / 1.1 / 12.0	0.0	38.3	54.0	-15.7
8348.4	39.0 Pk	8.0 / 36.4 / 46.6	36.8	V / 1.0 / 8.0	0.0	36.8	54.0	-17.2
8348.4	44.5 Pk	8.0 / 36.4 / 46.6	42.3	H / 1.0 / 8.0	0.0	42.3	54.0	-11.7
9276	39.6 Pk	8.5 / 36.9 / 47.7	37.3	V / 1.0 / 8.0	0.0	37.3	54.0	-16.7
9276	35.0 Pk	8.5 / 36.9 / 47.7	32.7	H / 1.0 / 8.0	0.0	32.7	54.0	-21.3

Example calculation:

<b>Measured Level</b>	+	<b>Transducer, Cable Loss &amp; Amplifier corrections</b>	=	<b>Corrected Reading</b>	<b>Specification Limit</b>	-	<b>Corrected Reading</b>	=	<b>Delta Specification</b>
		(dB)		(dBμV/m)	(dBμV/m)		(dBμV/m)		
		<b>14.9</b>		<b>28.9</b>	<b>40.0</b>		<b>28.9</b>		<b>-11.1</b>
(dBμV)									
<b>14.0</b>									

Deviations, Additions, or Exclusions: None

**6 AC Conducted Emissions – Not applicable to this test report****6.1 Method**

The test methods used comply with ANSI C63.4 and CISPR 16. Unless otherwise stated no deviations were made from **FCC Part 107, Class B**.

Intertek Louisville's emissions testing facility is located at 40 Meadow Rd. in Pinewood Springs CO 80540. The emissions testing facility is ISO17025:2005 accredited by NVLAP, our lab code is 200624-0, BSMI lab number is SL2-IN-E-029R, our VCCI registration no. R-1643, our FCC designation no. US5170 and our IC lab no. 2042N.

**6.2 Test Equipment Used:****6.3 Results:****6.4 Test Setup Photographs:****6.5 Test Summary Data:**

Test Result: Not Applicable to this test report

Minimum limit margin                                      ----- dB                                      at                                      ----- MHz

Remarks:

Note: Conducted Emissions was previously tested and passed. Refer to Report 100115937DEN-001 for details.

## 7 Measurement Uncertainty

The measured value related to the corresponding limit will be used to decide whether the equipment meets the requirements.

The measurement uncertainty figures were calculated and correspond to a coverage factor of  $k = 2$ , providing a confidence level of respectively 95.45 % in the case where the distributions characterizing the actual measurement uncertainties are normal (Gaussian).

Measurement uncertainty Table

Parameter	Uncertainty $\pm$	Notes
Radiated emissions, 10kHz to 1000 MHz	4.8 dB	
Radiated emissions, 1 to 18 GHz	4.9 dB	
AC mains Conducted emissions, 150kHz to 30 MHz	3.14 dB	
Disturbance Power 30 to 1000 MHz	3.3 dB	
Telecom Port Conducted emissions, Voltage 150 kHz to 30 MHz	TBD	In Process
Harmonics	-	Meets the requirements specified by the standard.
Flicker	-	Meets the requirements specified by the standard.

**8 Revision History**

<b>Revision Level</b>	<b>Date</b>	<b>Report Number</b>	<b>Notes</b>
0	TBD	100115937DEN-002B	Original Issue