

PRELIMINARY

REVISIONS			
REV.	DESCRIPTIONS	DATE	ECO
A	INITIAL RELEASE		

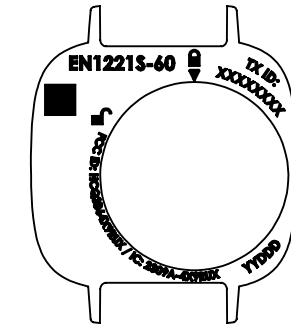

SCALE: 1:1

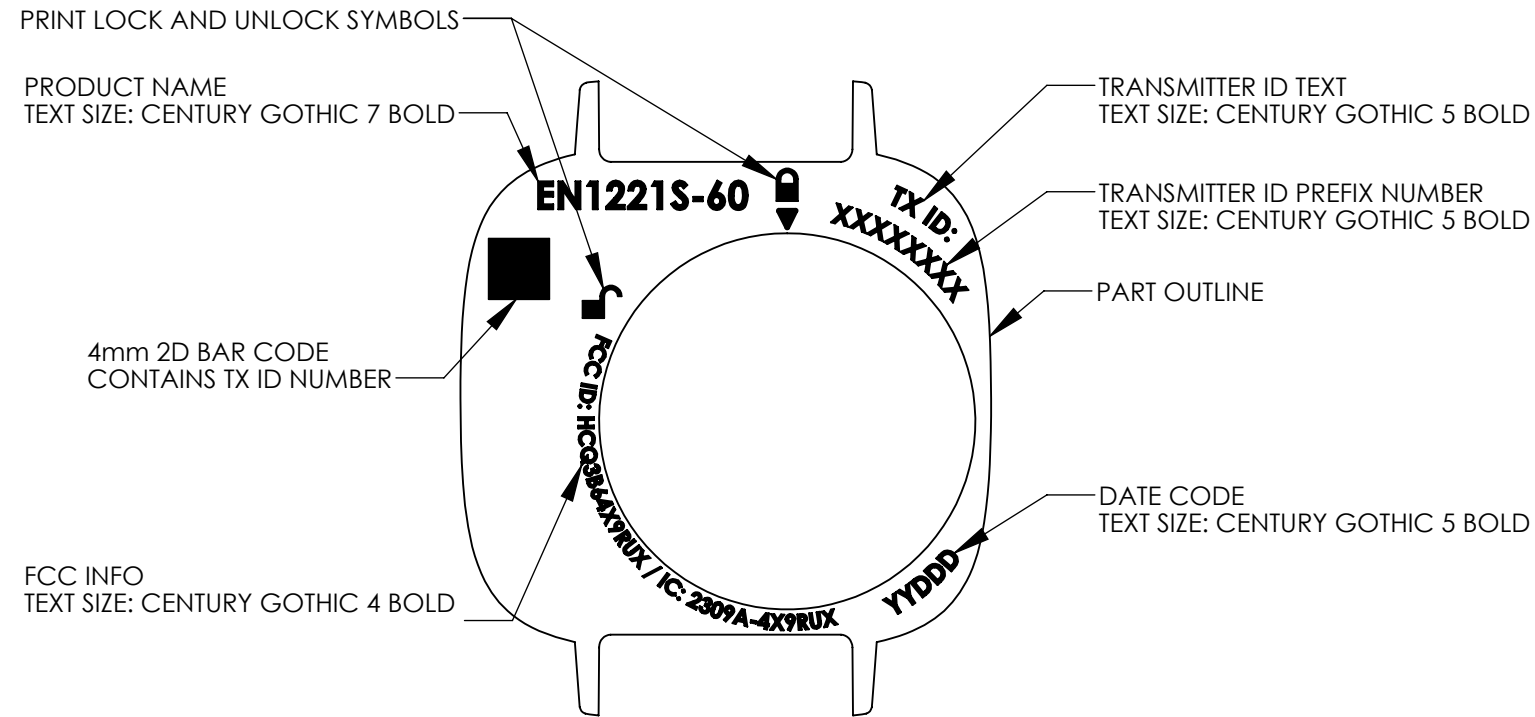
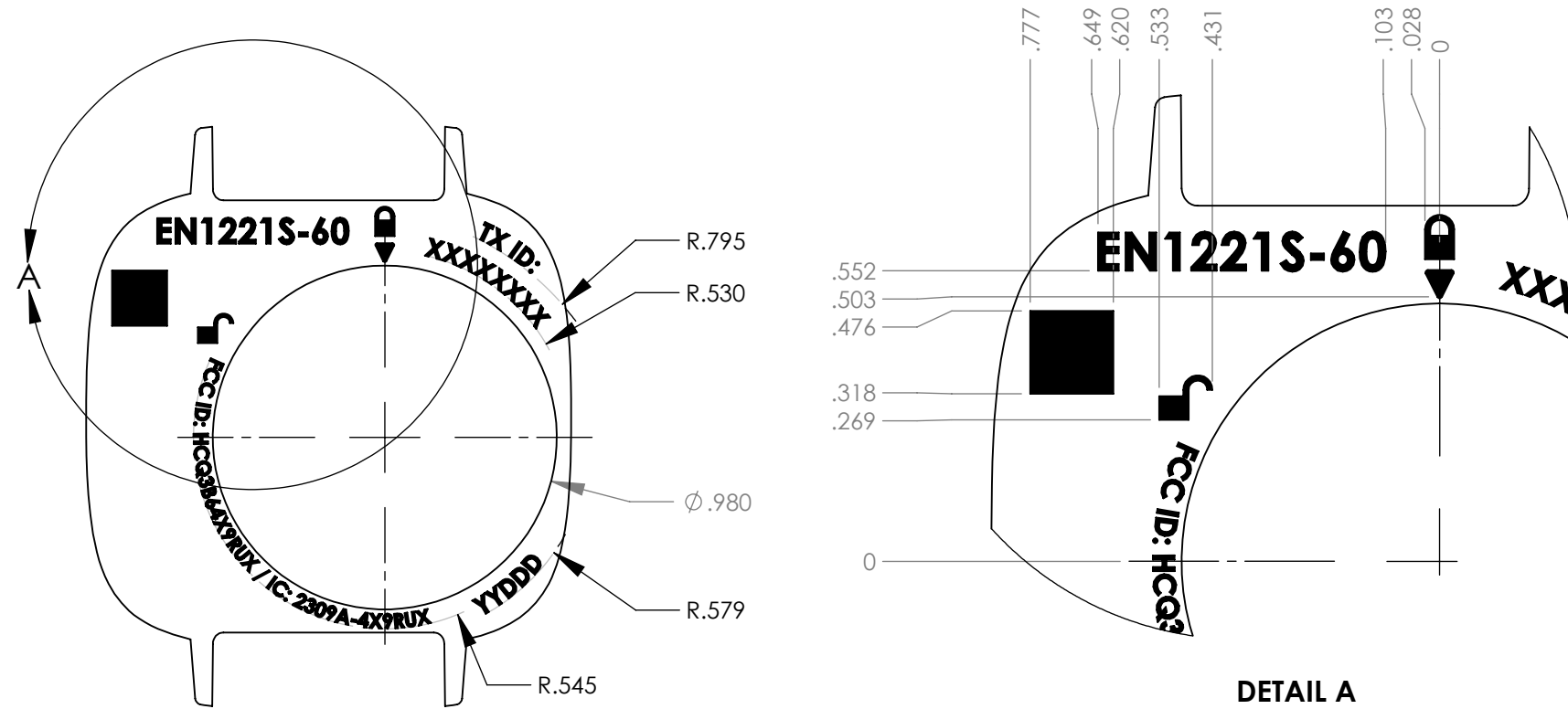

DETAIL A
SCALE 3: 1

NOTES: UNLESS OTHERWISE SPECIFIED

1. ALL DIMENSIONS ARE IN INCHES
2. OUTLINE INDICATES PRINTABLE AREA NOT ACTUAL PART.
3. COLOR OF TEXT: BLACK CONTRAST TBD BY TEST SETUP ARTWORK TO BE SUPPLIED BY INOVONICS.
4. A CERTIFICATION OF COMPLIANCE FOR MATERIAL AND QAP SPECIFICATION TO BE SUPPLIED WITH EACH SHIPMENT.
5. ALL MATERIALS MUST BE RoHS COMPLIANT TO THE CURRENT REVISION OF EU DIRECTIVE 2011/65/EU.
6. REFERENCE QUALITY ACCEPTANCE PLAN (QAP) DOC. QAP-06612.
7. CIRCLED DIMENSIONS ARE FOR QAP INSPECTION.

<p>CONFIDENTIAL DOCUMENTATION</p> <p>THE INFORMATION CONTAINED IN THIS DOCUMENT IS CONFIDENTIAL TO AND THE SOLE PROPERTY OF INOVONICS CORPORATION. RECEIPT OF THIS INFORMATION REQUIRES THE EXISTENCE AND FULL ACCEPTANCE OF THE TERMS AND CONDITIONS OF A NON DISCLOSURE AGREEMENT AND SIGNED BY THE INOVONICS CORPORATION AND THE RECIPIENT. THIS DOCUMENTATION IS NOT TO BE REPRODUCED OR REDISTRIBUTED EXCEPT AS PROVIDED IN THE NON DISCLOSURE AGREEMENT.</p>	CAD GENERATED DRAWING, DO NOT MANUALLY UPDATE OR SCALE DRAWING. UNLESS OTHERWISE SPECIFIED		<p>WWW.INOVONICS.COM</p>	
	MATERIAL:	SEE NOTES		DESCRIPTION:
	VOLUME:	1867.829	<p>LBL-PEND1 BOT-LZR ETCH TEMPLATE</p>	
	TOLERANCE:	XXX=+/- .005 XX=+/- .010	PART NO:	06612
	AUTHOR:	SL	REV.:	A
DRAWN DATE:	8/19/2014	SCALE:	2:1	
		SIZE:	B	
		SHEET	1 OF 1	